

COLUMBIA LIBRARIES OFFSITE
HEALTH SCIENCES STANDARD



HX00023051

FROM THE LIBRARY OF



WILLIAM DUNCAN MCKIM

GRADUATE OF
COLUMBIA UNIVERSITY

A. B., 1875; A. M., 1878; M. D., 1878

QP34

L232

V.2

Columbia University
in the City of New York
College of Physicians and Surgeons
Library



A MANUAL
OF
HUMAN PHYSIOLOGY.

VOL. II.

W. Duncan Mc

A MANUAL OF
HUMAN PHYSIOLOGY,

INCLUDING

HISTOLOGY AND MICROSCOPICAL ANATOMY;

WITH SPECIAL REFERENCE TO THE REQUIREMENTS OF

PRACTICAL MEDICINE.

BY

DR. L. LANDOIS,

PROFESSOR OF PHYSIOLOGY AND DIRECTOR OF THE PHYSIOLOGICAL INSTITUTE,
UNIVERSITY OF GREIFSWALD.

TRANSLATED FROM THE FOURTH GERMAN EDITION.

WITH ADDITIONS BY

WILLIAM STIRLING, M.D., Sc.D.,

REGIUS PROFESSOR OF THE INSTITUTES OF MEDICINE OR PHYSIOLOGY IN THE UNIVERSITY OF ABERDEEN.

WITH 318 ILLUSTRATIONS.

VOL. II.

PHILADELPHIA:
P. BLAKISTON, SON, AND COMPANY,
1012 WALNUT STREET.

1885.

[*All Rights Reserved.*]

QP34

L232

v.2

PREFATORY NOTE TO VOL. II.

IN bringing the Translation of Professor LANDOIS' Treatise to a close, I would only remark that the same plan has been followed with the Second as with the First Volume, and additions made to the original wherever they appeared desirable for English readers. Such additions are, as before, distinguished by square brackets [].

The Illustrations also have again been greatly increased. Taking the work as a whole, they number 494, as compared with the 275 of the original. I have to acknowledge the courtesy of my publishers, Messrs. Charles Griffin & Company, in acceding thus liberally to my wishes in this respect, and must also express my thanks for several Illustrations to Drs. Byrom Bramwell, Knott, R. W. Reid, Hart and Barbour, Professor M'Kendrick, Mons. Kœnig, Messrs. Elliott Brothers, Messrs. Pickard & Curry, Messrs. John Weiss & Son, and Messrs. Krohne & Sesemann.

The sources of the others will be found duly noted in the List of Illustrations, and include the works of Professors Aitken and W. K. Parker, MM. Charcot, Gegenbaur, Kölliker, Marey, Schwalbe, and Tyson, as well as some of those mentioned in Vol. I.

In addition to the works just quoted, I have also to express my indebtedness to Ross's *Treatise on the Diseases of the Nervous System*, Tyson *On Bright's Disease and Diabetes*, and Bramwell *On Diseases of the Spinal Cord*. Finally, my thanks are due to Professor Burdon Sanderson and Dr. Lauder Brunton for their generous assistance in connection with the exact rendering of certain technical terms.

WM. STIRLING.

ABERDEEN UNIVERSITY,
May, 1885.

GENERAL CONTENTS.

VIII. THE SECRETION OF URINE.

SECTION	PAGE
254. Structure of the Kidney,	515
255. The Urine,	525
256. Urea,	530
257. Qualitative and Quantitative Estimation of Urea,	533
258. Uric Acid,	534
259. Qualitative and Quantitative Estimation of Uric Acid,	537
260. Kreatinin and other Substances,	538
261. Colouring Matters of the Urine,	542
262. Indigo, Phenol, Kresol, Pyrokatechin,	543
263. Inorganic Urinary Constituents and Changes in Urine,	548
264. Albumin in Urine,	551
265. Blood in Urine,	555
266. Bile in Urine,	558
267. Sugar in Urine,	559
268. Cystin,	562
269. Leucin, Tyrosin,	563
270. Deposits in Urine,	564
271. General Scheme for Detecting Urinary Deposits,	567
272. Urinary Calculi,	568
273. The Secretion of Urine,	570
274. The Preparation of Urine,	576
275. Passage of Various Substances into the Urine,	578
276. Influence of Nerves on the Renal Secretion,	579
277. Uræmia, Ammoniaemia,	584
278. Structure and Functions of the Ureter,	585
279. Urinary Bladder and Urethra,	586
280. Accumulation and Retention of Urine,	589
281. Retention and Incontinence of Urine,	592
282. Comparative and Historical,	592

IX. FUNCTIONS OF THE SKIN.

283. Structure of the Skin,	593
284. Nails and Hair,	597
285. The Glands of the Skin,	601
286. The Skin as a Protective Covering,	602
287. Cutaneous Respiration and Secretion—Sweat,	603
288. Conditions Influencing the Secretion of Sweat,	606
289. Pathological Variations,	609
290. Cutaneous Absorption—Galvanic Conduction,	610
291. Comparative—Historical,	611

X. PHYSIOLOGY OF THE MOTOR APPARATUS.

SECTION	PAGE
292. Ciliary Motion,	612
292A. Structure and Arrangement of the Muscles,	614
293. Physical and Chemical Properties of Muscle,	624
294. Metabolism in Muscle,	626
295. Rigor mortis,	629
296. Muscular Excitability,	633
297. Changes in a Muscle during Contraction,	639
298. Muscular Contraction,	643
299. Rapidity of Transmission of a Muscular Contraction,	656
300. Muscular Work,	658
301. The Elasticity of Muscle,	661
302. Formation of Heat in an Active Muscle,	664
303. The Muscle-Sound,	666
304. Fatigue of Muscle,	667
305. The Mechanism of the Joints,	669
306. Arrangement and Uses of the Muscles of the Body,	672
307. Gymnastics—Pathological Motor Variations,	676
308. Standing,	678
309. Sitting,	680
310. Walking and Running,	681
311. Comparative,	683

VOICE AND SPEECH.

312. Voice and Speech,	685
313. Arrangements of the Larynx,	686
314. Organs of Voice—Laryngoscopy,	693
315. Conditions Modifying the Laryngeal Sounds,	697
316. Range of the Voice,	699
317. Speech—The Vowels,	699
318. The Consonants,	703
319. Pathological Variations of Voice and Speech,	705
320. Comparative—Historical,	706

XI. GENERAL PHYSIOLOGY OF THE NERVES AND ELECTRO-PHYSIOLOGY.

321. Structure and Arrangement of the Nerve-Elements,	709
322. Chemistry of the Nerve-Substance,	718
323. Metabolism of Nerves,	720
324. Excitability of Nerves—Stimuli,	720
325. Diminution of the Excitability—Degeneration and Regeneration of Nerves,	726
326. The Galvanic Current,	732
327. Action of the Galvanic Current—Galvanometer,	734
328. Electrolysis,	736
329. Induction—Extra Current—Magneto-Induction,	742
330. Du Bois-Reymond's Inductorium,	745
331. Electrical Currents in Passive Muscle and Nerve,	749
332. Currents of Stimulated Muscle and Nerve,	752
333. Currents in Nerve and Muscle during Electrotonus,	755
334. Theories of Muscle and Nerve Currents,	757
335. Alterations during Electrotonus,	760

SECTION	PAGE
336. Electrotonus—Law of Contraction,	763
337. Rapidity of Transmission of Nervous Impulses,	766
338. Double Conduction in Nerves,	770
339. Therapeutical Uses of Electricity—Reaction of Degeneration,	772
340. Electrical Charging of the Body,	778
341. Comparative—Historical,	779

XII. PHYSIOLOGY OF THE PERIPHERAL NERVES.

342. Classification of Nerve-Fibres,	781
343. Nervus Olfactorius,	784
344. Nervus Opticus,	785
345. Nervus Oculomotorius,	788
346. Nervus Trochlearis,	790
347. Nervus Trigemini,	790
348. Nervus Abducens,	803
349. Nervus Facialis,	804
350. Nervus Acusticus,	809
351. Nervus Glosso-pharyngeus,	813
352. Nervus Vagus,	814
353. Nervus Accessorius,	823
354. Nervus Hypoglossus,	824
355. The Spinal Nerves,	825
356. The Sympathetic Nerve,	830
357. Comparative—Historical,	834

XIII. PHYSIOLOGY OF THE NERVE-CENTRES.

358. General,	835
359. Structure of the Spinal Cord,	835
360. Spinal Reflexes,	843
361. Inhibition of the Reflexes,	847
362. Centres in the Spinal Cord,	852
363. Excitability of the Spinal Cord,	854
364. The Conducting Paths in the Spinal Cord,	856
365. General Schema of the Brain,	861
366. The Medulla Oblongata,	870
367. Reflex Centres of the Medulla Oblongata,	874
368. The Respiratory Centre,	876
369. The Cardio-Inhibitory Centre,	884
370. The Accelerans Cordis Centre,	887
371. Vaso-motor Centre and Vaso-motor Nerves,	890
372. Vaso-dilator Centre and Vaso-dilator Nerves,	900
373. The Spasm Centre—The Sweat Centre,	901
374. Psychological Functions of the Cerebrum,	903
375. The Motor Centres of the Cerebrum,	910
376. The Sensory Cortical Centres,	920
377. The Thermal Cortical Centres,	924
378. Topography of the Cortex Cerebri,	925
379. The Basal Ganglia—The Mid-brain,	935
380. The Structure and Functions of the Cerebellum,	943
381. The Protective Apparatus of the Brain,	946
382. Comparative—Historical,	950

XIV. PHYSIOLOGY OF THE SENSE ORGANS.

I. SIGHT.

SECTION	PAGE
383. Introductory Observations,	952
384. Histology of the Eye,	955
385. Dioptric Observations,	966
386. Formation of a Retinal Image,	972
387. Accommodation of the Eye,	975
388. Normal and Abnormal Refraction,	981
389. The Power of Accommodation,	984
390. Spectacles,	986
391. Chromatic Aberration and Astigmatism,	987
392. The Iris,	989
393. Entoptical Phenomena,	994
394. The Ophthalmoscope,	997
395. Activity of the Retina in Vision,	1002
396. Perception of Colours,	1009
397. Colour-blindness,	1016
398. Stimulation of the Retina,	1018
399. Movements of the Eyeballs,	1022
400. Binocular Vision,	1028
401. Single Vision—Identical Points,	1029
402. Stereoscopic Vision,	1031
403. Estimation of Size and Distance,	1035
404. Protective Organs of the Eye,	1038
405. Comparative—Historical,	1040

2. HEARING.

406. Structure of the Organ of Hearing,	1043
407. Physical Introduction,	1045
408. Ear Muscles,	1046
409. Tympanic Membrane,	1046
410. The Auditory Ossicles and their Muscles,	1049
411. Eustachian Tube—Tympanum,	1055
412. Conduction of Sound in the Labyrinth,	1057
413. Structure of the Labyrinth,	1059
414. Auditory Perceptions of Pitch,	1063
415. Perception of Quality—Vowels,	1067
416. Action of the Labyrinth,	1072
417. Harmony—Discords—Beats,	1073
418. Perception of Sound,	1075
419. Comparative—Historical,	1076

3. SMELL.

420. Structure of the Organ of Smell,	1077
421. Olfactory Sensations,	1078

4. TASTE.

422. Position and Structure of the Organs of Taste,	1080
423. Gustatory Sensations,	1081

5. TOUCH.

SECTION	PAGE
424. Terminations of Sensory Nerves,	1083
425. Sensory and Tactile Sensations,	1087
426. The Sense of Locality,	1088
427. The Pressure Sense,	1091
428. The Temperature Sense,	1094
429. Common Sensation—Pain,	1096
430. The Muscular Sense,	1098

XV. PHYSIOLOGY OF REPRODUCTION AND DEVELOPMENT.

431. Forms of Reproduction,	1100
432. Seminal Fluid,	1102
433. The Ovary—Ovum—Uterus,	1106
434. Puberty,	1112
435. Menstruation,	1113
436. Erection,	1116
437. Ejaculation—Reception of the Semen,	1119
438. Fertilisation of the Ovum,	1120
439. Impregnation and Cleavage of the Ovum,	1121
440. Structures formed from the Epiblast,	1125
441. Structures formed from the Mesoblast and Hypoblast,	1127
442. Formation of the Heart and Embryo,	1129
443. Further Formation of the Body,	1131
444. Formation of the Amnion and Allantois,	1133
445. Human Fœtal Membranes—Placenta,	1135
446. Chronology of Human Development,	1140
447. Formation of the Osseous System,	1141
448. Development of the Vascular System,	1148
449. Formation of the Intestinal Canal,	1152
450. Development of the Genito-urinary Organs,	1154
451. Formation of the Central Nervous System,	1159
452. Development of the Sense Organs,	1160
453. Birth,	1161
454. Comparative—Historical,	1163

LIST OF ILLUSTRATIONS.

FIGURE	PAGE
*177. Longitudinal section of the kidney (Heule),	515
*178. Malpighian pyramid (Tyson, after Ludwig),	516
*179. Scheme of the uriniferous tubules (Klein and Noble-Smith),	517
180. Scheme of the structure of the kidney,	519
181. Glomerulus and renal tubules,	520
*182. Convoluted renal tubule (Heidenhain),	521
*183. Irregular tubule (Tyson, after Klein),	522
184. Graduated urinary flask,	526
185. Urinometer,	526
186. Graduated burette,	528
187. Urea and urea nitrate,	530
*188. Oxalate of urea (after Beale),	532
189. Graduated pipette,	533
*190. Uric acid,	535
*191. Uric acid (Wedl),	535
192. Kreatinin-zinc chloride,	538
*193. Oxalate of lime (Wedl),	540
*194. Oxalate of lime,	540
195. Hippuric acid,	540
196. Spermatozoa and calcic phosphate,	547
197. Deposit in urine during the "acid fermentation,"	549
198. Deposit in ammoniacal urine,	549
199. Deposit in ammoniacal urine,	550
*200. Ammonio-magnesian phosphate and urates,	551
*201. Triple phosphate,	551
202. Spectroscopic examination of urine,	555
203. Blood-corpuscles in urine,	556
204. Crenated blood-corpuscles in urine,	556
205. Coloured and colourless corpuscles in urine,	557
206. Blood-corpuscles and triple phosphate,	558
207. Soleil-Ventzke's polariscope,	561
*208. Inosit (Beale, after Funke),	562
209. Cystin and oxalate of lime,	563
210. Leucin, tyrosin, and ammonium urate,	563
211. Epithelium from the genito-urinary apparatus,	564
212. Micrococci and fungi in urine,	565
213. Blood and granular tube casts,	566
214. Hyaline casts,	566
*215. Uric acid (after Funke),	567
*216. Oxalate of lime,	568
*217. Cystin (after Thudichum),	568
*218. Oncometer (Stirling, after Roy),	581
*219. Oncograph (Stirling, after Roy),	581

FIGURE	PAGE
*220. Renal oncograph curve (Stirling, after Roy),	582
*221. Transitional epithelium (Beale),	587
222. View of the trigone of the bladder,	587
223. Scheme of the structure of the skin,	594
224. Vertical section of the skin,	595
*225. Papillæ of the skin injected,	596
*226. Margarin crystals in fat-cells,	596
227. Transverse section of a nail,	597
228. Transverse section of a hair-follicle,	598
229. Section of a hair-follicle,	600
230. Sebaceous gland,	601
231. Histology of muscular tissue,	615
*232. Muscular fibre (Knott, after Quain),	617
233. Tendon attached to a muscle,	619
*234. Injected blood-vessels of muscle (Kölliker),	620
235. Termination of a nerve in muscle,	620
*236. Purkinje's fibres (Ranvier),	622
*237. Non-striped muscle-cell (Stirling),	623
*238. Scheme of the curara experiment (after Rutherford),	635
*239. Platinum electrodes (Elliott Brothers),	636
240. Microscopic appearances in contracting muscle,	641
241. Helmholtz's myograph,	643
*242. Pendulum myograph,	644
*243. Scheme of the pendulum myograph (Stirling),	645
*244. Du Bois-Reymond's spring myograph,	645
245. Muscle-curve,	647
*246. Method of studying a muscular contraction (after Rutherford),	648
247. Muscle-curves,	649
248. Muscle-curves,	649
249. Muscle-curves,	652
*250. Curves of a red and pale muscle (Kronecker and Stirling),	654
*251. Muscle-curves (Kronecker and Stirling),	654
*252. Tone-inductorium (Kronecker and Stirling),	655
*253. Muscle-curve (Kronecker and Stirling),	656
*254. Muscle-curves (Marey),	657
*255. Height of the lift by a muscle,	659
*256. Dynamometer,	660
*257. Curves of elasticity (after Marey),	661
*258. Curve of elasticity of a muscle (after Marey),	662
259. Scheme of the action of muscles on bones,	674
260. Phases of walking,	681
261. Larynx from the front,	687
262. Larynx from behind,	687
263. Larynx from behind,	688
264. Nerves of the Larynx,	688
265. Action of the posterior crico-arytenoid muscles,	689
266. Action of the arytenoid muscles,	689
267. Action of the lateral crico-arytenoid muscles,	690
268. Vertical section of the head and neck,	694
269. Examination of the larynx,	695
270. Laryngoscopic view of the larynx,	695
271. View of the larynx during a high note,	696
272. View of the larynx during a deep inspiration,	696
273. Rhinoscopy,	697
274. View of the posterior nares,	697

FIGURE

	PAGE
275. Parts concerned in phonation,	701
276. Tumours on the vocal cords,	705
277. Histology of nervous tissues,	710
278. Medullated nerve-fibre,	713
*279. Ranvier's crosses (Knott, after Ranvier),	713
280. Transverse section of a nerve,	715
*281. Cell from the Gasserian ganglion (Schwalbe),	717
282. Degeneration and regeneration of nerve-fibres,	727
*283. Waller's experiments (after Dalton),	728
284. Rheocord of du Bois-Reymond,	734
285. Scheme of a galvanometer,	736
*286. Large Grove's battery (Gscheidlen),	738
*287. Grennet's battery (Gscheidlen),	738
*288. Leclanché's element (Gscheidlen),	793
*289. Non-polarisable electrodes (Elliott Brothers),	740
*290. Thomson's galvanometer (Elliott Brothers),	740
*291. Lamp and scale (Elliott Brothers),	741
*292. Galvanometer shunt (Elliott Brothers),	741
*293. Scheme of the induced currents (Hermann),	744
*294. Helmholtz's modification (Hermann),	744
295. Scheme of an induction machine,	746
*296. Inductorium (Elliott Brothers),	746
297. Stührer's apparatus,	747
*298. Friction key (Elliott Brothers),	747
*299. Plug key,	748
*300. Capillary contact (Kronecker and Stirling),	748
301. Scheme of the muscle-current,	749
*302. Secondary contraction,	753
*303. Nerve-muscle preparation,	753
304. Nerve-current in electrotonus,	756
305. Scheme of electrotonic excitability,	761
306. Method of testing electrotonic excitability,	762
307. Velocity of nerve-energy,	767
*308. Scheme for testing velocity of a nerve-impulse,	768
*309. Curves of a nerve-impulse (Marey),	769
*310. Sponge rheophores (Weiss),	772
*311. Disk rheophore (Weiss),	772
*312. Metallic brush (Weiss),	772
313. Motor points of the arm,	773
314. Motor points of the arm,	774
315. Motor points of the leg,	775
316. Motor points of the leg,	776
*317. Scheme of a reflex act (Stirling),	784
318. Optic chiasma,	786
*319. Decussation of the optic tracts (Knott, after Charcot),	787
*320. Visual cortical centres (Munk),	787
*321. Under surface of the brain,	791
322. Connections of the cranial nerves,	794
323. Sensory nerves of the face,	801
324. Motor points of the face and neck,	807
*325. Disposition of the semicircular canals (W. Stirling),	811
*326. Cardiac nerves of the rabbit (W. Stirling),	817
*327. Cell from the Gasserian ganglion (Schwalbe),	826
328. Cutaneous nerves of the arm,	826
329. Cutaneous nerves of the leg (Henle),	829

FIGURE	PAGE
330. Transverse section of the spinal cord,	836
*331. Relation of white and grey matter of the cord (Schäfer),	837
*332. Transverse sections of the spinal cord,	838
*333. Multipolar nerve-cell,	839
*334. Injected blood-vessels of the cord (Kölliker),	840
335. Conducting paths in the cord,	840
*336. Degeneration paths in the cord (Bramwell),	842
*337. Scheme of a reflex act (W. Stirling),	843
*338. Section of a spinal segment (W. Stirling),	843
*339. Vertical section of the cerebrum (Meynert),	862
*340. Injected cerebral convolution (Duret),	863
341. Scheme of the brain,	864
*342. Connections of the cerebellum,	866
*343. Diagram of a spinal segment (Bramwell),	867
*344. Section across the pyramids (Schwalbe),	871
*345. Section of the medulla oblongata (Schwalbe),	872
*346. Section of the olivary body (Schwalbe),	872
347. Medulla oblongata with its centres,	873
*348. Scheme of the respiratory centres and their connections (after Rutherford),	878
*349. Scheme of the accelerans fibres (W. Stirling),	888
*350. Cardiac plexus of a cat (Knott, after Böhm),	889
*351. Frog without its cerebrum (Stirling, after Goltz),	905
*352. Frog without its cerebrum (Stirling, after Goltz),	905
*353. Left side of the human brain (Ecker),	910
*354. Inner aspect of right hemisphere (Ecker),	911
*355. Left frontal lobe and island of Reil (Turner),	912
*356. Brain from above (Ecker),	913
357. Cerebrum of dog, carp, frog, pigeon, and rabbit,	915
358. The cerebral sensory centres,	920
*359. Psycho-optic fibres (Munk),	921
360. Relation of the cerebral convolutions to the skull,	926
*361. Section of a cerebral peduncle (Charcot),	928
362. Inner surface of the human brain,	931
*363. Relation of the convolutions to the skull (R. W. Reid),	934
*364. Basal ganglia and the ventricles,	936
365. Section of the human brain,	937
*366. Transverse section of the right hemisphere (Gegenbaur),	938
*367. Section of the cerebellum (Sankey),	943
*368. Cortex cerebri and its membranes (Schwalbe),	946
*369. Circle of Willis (Charcot),	948
*370. Ganglionic arteries (Charcot),	949
*371. Corneal corpuscles (Ranvier),	956
*372. Corneal spaces (Ranvier),	956
373. Junction of the cornea and sclerotic,	957
374. Blood-vessels of the eyeball,	959
375. Layers of the retina,	962
*376. Fibres of the lens (Kölliker),	963
377. Section of the optic nerve,	964
378. Action of lenses on light,	967
379. Refraction of light,	968
380. Construction of the refracted ray,	968
381. Optical cardinal points,	969
382. Construction of the refracted ray,	970
383. Construction of the image,	970

FIGURE	PAGE
384. Refracted ray in several media,	971
385. Visual angle and retinal image,	973
386. Scheme of the ophthalmometer,	974
387. Horizontal section of the eyeball,	976
388. Scheme of accommodation,	977
389. Sanson-Purkinje's images,	978
*390. Phakoscope (M'Kendrick),	979
391. Scheiner's experiment,	981
392. Refraction of the eye,	982
393. Myopic eye,	982
394. Hypermetropic eye,	983
395. Power of accommodation,	985
*396. Diagram of astigmatism.	988
397. Cylindrical glasses,	989
398. Scheme of the nerves of the iris (after Erb),	992
*399. Pupilometer (Gorham),	993
*400. Pupilometer (Gorham),	993
401. Entoptical shadows,	994
402. Scheme of the original ophthalmoscope,	998
403. Scheme of the indirect method,	998
404. Action of a divergent lens,	998
405. Action of a divergent lens,	999
406. View of the fundus oculi,	999
*407. Morton's ophthalmoscope (Pickard and Curry),	1000
*408. Frost's artificial eye (Pickard and Curry),	1001
409. Action of the orthoscope,	1001
*410. Mariotte's experiment,	1002
411. Horizontal section of the right eye,	1004
*412. M'Hardy's perimeter (Pickard and Curry),	1006
*413. Priestley Smith's perimeter (Pickard and Curry),	1007
414. Perimetric chart,	1008
415. Geometrical colour cone,	1012
416. Action of light on the retina,	1013
417. Scheme of the action of the ocular muscles,	1026
418. Identical points of the retina,	1029
419. The horopter,	1029
420. Two stereoscopic drawings,	1032
421. Brewster's stereoscope,	1033
422. Wheatstone's stereoscope,	1033
423. Telestereoscope,	1034
424. Wheatstone's pseudoscope,	1035
425. Rollett's apparatus,	1037
426. Section of an eyelid,	1039
427. Scheme of the organ of hearing,	1041
428. External auditory meatus,	1046
429. Left tympanic membrane and ossicles,	1047
430. Membrana tympani and ossicles,	1047
431. Tympanic membrane from within,	1047
*432. Ear specula (Krohne and Sesemann),	1048
*433. Toynbee's artificial membrana tympani (Krohne and Sesemann),	1049
434. Right auditory ossicles,	1050
435. Tympanum and auditory ossicles,	1050
436. Tensor tympani and Eustachian tube,	1053
437. Right stapedius muscle,	1054
*438. Eustachian catheter,	1057

FIGURE	PAGE
*439. Politzer's ear bag (Krohne and Sesemann),	1057
440. Right labyrinth,	1057
441. Scheme of the cochlea,	1059
*442. Interior of the right labyrinth,	1060
*443. Semicircular canals,	1060
444. Scheme of the canalis cochlearis,	1061
*445. Galton's whistle (Krohne and Sesemann),	1065
446. Curve of a musical note and its overtones,	1068
*447. Kœnig's manometric capsule (Kœnig),	1070
*448. Flame-pictures of vowels (M'Kendrick),	1070
*449. Kœnig's analysing apparatus (Kœnig),	1071
450. Olfactory cells,	1078
451. Nasal and pharyngo-nasal cavities,	1078
452. Circumvallate papilla and taste-bulbs,	1081
453. Vertical section of skin,	1084
454. Pacini's corpuscle,	1085
455. Æsthesiometer,	1088
*456. Æsthesiometer of Sieveking,	1089
*457. Aristotle's experiment (Knott),	1091
458. Landois' mercurial pressure balance,	1092
*459. Intra-cellular plexus (Knott, after Klein),	1100
*460. Karyokinesis (Gegenbaur),	1100
461. Spermatic crystals,	1103
462. Spermatozoa,	1104
463. Spermatogenesis,	1105
*464. A cat's ovary (Hart and Barbour, after Schrön),	1106
*465. Section of an ovary (Turner),	1107
466. Ovary and polar globules,	1108
*467. Mucous membrane of the uterus (Hart and Barbour, after Turner),	1111
*468. Fallopian tube and its annexes (Hart and Barbour),	1112
*469. Uterus before menstruation,	1114
*470. Uterus after menstruation (J. Williams),	1114
471. The urethra and adjoining muscles,	1118
472. Cleavage of the yolk,	1122
473. The blastoderm,	1124
474. Schemata of development,	1126
*475. Embryo of the mole (W. K. Parker),	1132
*476. Uterine mucous membrane (Coste),	1135
477. Hare-lip,	1143
*478. Meckel's cartilage (W. K. Parker),	1144
479. Centres of ossification in the innominate bone,	1146
480. Development of the heart,	1149
481. The aortic arches,	1150
482. Veins of the embryo,	1150
483. Development of the veins and portal system,	1151
484. Development of the intestine,	1152
485. Development of the lungs,	1152
486. Formation of the omentum,	1154
487. Development of the internal generative organs,	1155
488. Development of the external genitals,	1157
*489.)	1158
*490.)	1158
*491.) Changes in the external organs of generation in the female	1158
*492.) (after Schroëder),	1158
*493.)	1158
494. Development of the eye,	1160

The Secretion of Urine.

254. Structure of the Kidney.

THE kidneys are compound tubular glands (Fig. 180).

[**Capsule.**—The kidney is invested by a thin, tough, fibrous capsule, easily stripped off from the substance of the organ to which it is attached by fine processes of connective-tissue and blood-vessels. None of the secretory substance is removed with it. Under the capsule in the human kidney, there is a thin plexus on non-striped muscular fibres. At the hilum it becomes continuous with the outer fibrous coat of the dilated upper end of the ureter.]

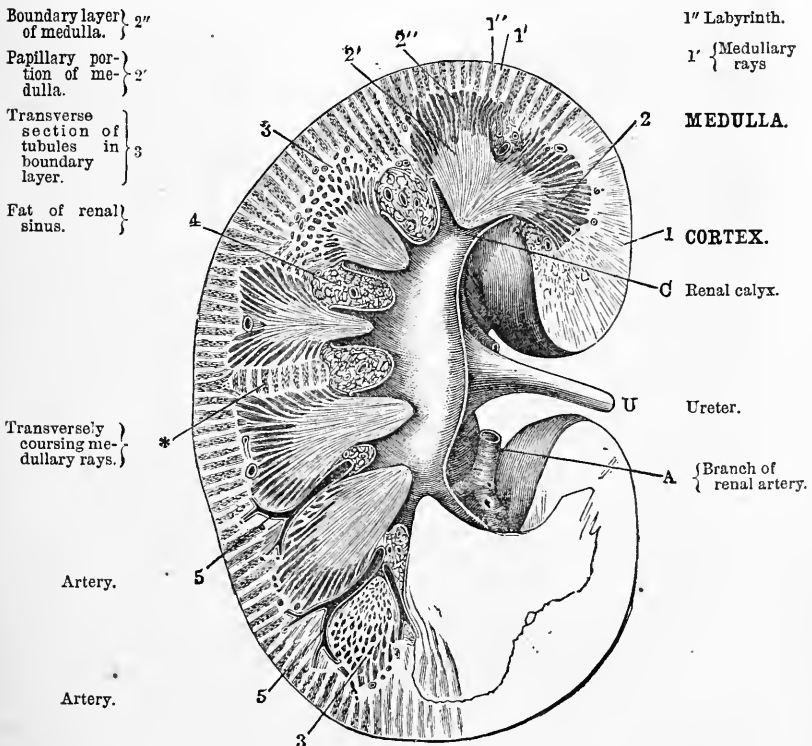

Fig. 177.

Longitudinal section through the kidney (Tyson, after Henle).

[**Naked Eye Appearances.**—On dividing the kidney longitudinally from the hilum to its outer border, and examining the cut surface with the naked eye, we observe the **parenchyma** of the kidney, consisting of an outer *cortical* and an inner *medullary*, or pyramidal portion, the latter composed of about twelve conical papillæ, or Pyramids of Malpighi, with their apices directed towards the pelvis of the organ, and embraced by the calices of the pelvis of the kidney (Fig. 177). The medullary portion is further subdivided into the *boundary layer* of Ludwig and the *papillary* portion. According to Klein, the relative proportions of these three parts are—cortex, 3·5; boundary layer, 2·5; and papillary portion, 4.

The cortex has a light-brown colour, and when torn it presents a slightly granular aspect, with radiating lines running at regular distances. The granules are due to the presence of the Malpighian corpuscles, and the striæ to the medullary rays. The boundary zone is darker, and often purplish in colour. It is striated with clear and red lines alternating with opaque ones, the former being blood-vessels and the latter uriniferous tubules. The papillary zone is nearly white and

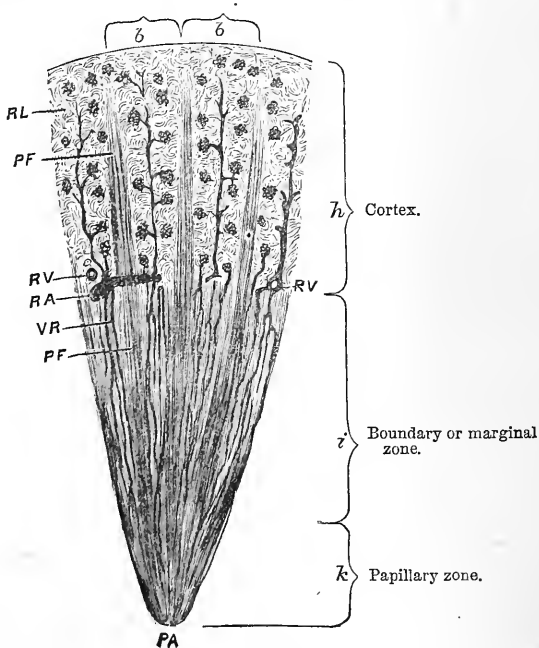

Fig. 178.

Longitudinal section of a kidney (Tyson, modified from Ludwig)—PF, pyramids of Ferrein; RA, branch of renal artery; RV, lumen of a renal vein receiving an interlobular vein; VR, vasa recta; PA, apex of a renal papilla; *b*, *b*, embrace the bases of the renal lobules.

uniformly striated, the striæ converging to the apex of the pyramid. The medulla is much denser and less friable than the cortex, owing to the presence of a large amount of connective-tissue between the tubules. The bundles of straight tubes of the medulla may be traced at regular intervals running outwards into the cortex, constituting *medullary rays*, which become smaller as they pass outwards in the cortical zone, so that they are conical and form the pyramids of Ferrein (Fig. 178, P F). The portion of the cortex lying between the medullary rays is known as the *labyrinth*, from the complicated arrangement of its tubules.]

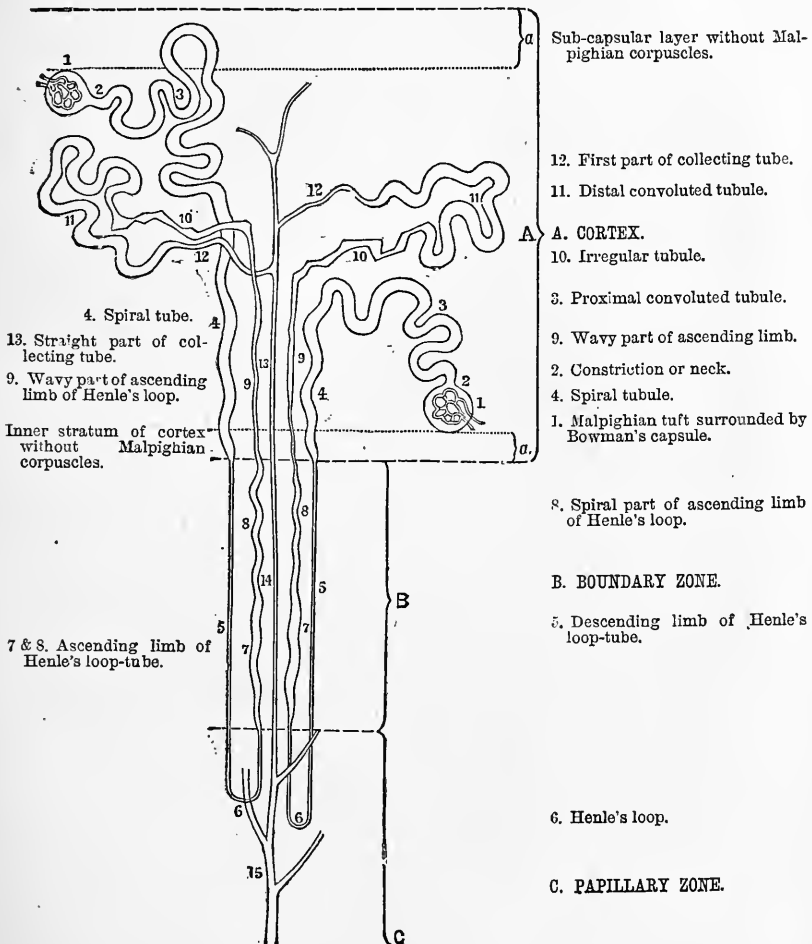

Fig. 179.

Diagram of the course of two uriniferous tubules (Tyson and Brunton, after Klein and Noble-Smith).

[**Size, Weight.**—The adult kidney is about 11 centimetres (4·4 inches) in length, 5 centimetres (2 inches) wide, and ·75 centimetres (·3 inches) in thickness. It weighs in the male 113·5–170 grms. (4 to 6 oz.), in the female 113·5 to 156 grms. (4 to 5½ oz.). The width of the cortex is usually 5 to 6 millimetres ($\frac{1}{5}$ to $\frac{1}{4}$ inch—Tyson).]

The **uriniferous tubules** all arise within the labyrinth of the cortex by means of a globular enlargement, 200–300 μ [$\frac{1}{160}$ to $\frac{1}{125}$ inch] in diameter, called *Bowman's capsule* (Fig. 179 and Fig. 180), and after pursuing a complicated course, altering their direction, diameter, and structure, and being joined by other tubules, they ultimately form large collecting tubes, which terminate by minute apertures, visible with the aid of a hand-lens, on the apices of the papillæ projecting into the calices of the kidney.

Each urinary tubule is composed of a homogeneous *membrana propria*, lined by epithelial cells so as to leave a lumen for the passage of the urine from the Malpighian corpuscles to the pelvis of the kidney. The diameter and direction of the tubules vary, and the epithelium differs in its characters at different parts of the tube, while the lumen also undergoes alterations in its diameter.

Course and Structure of the Tubules.—In the labyrinth of the cortex, tubules arise in the spherical enlargement known as Bowman's Capsule (Fig. 179, 1), which invests (in the manner presently to be described) the tuft of capillary blood-vessels called a *glomerulus* or *Malpighian corpuscle*. By means of a short and narrow neck (2) the capsule becomes continuous with a convoluted tubule at *x* in Fig. 180 (Bowman). This tubule is of considerable length, forming many windings in the cortex (Fig. 179, 3); the first part of it is 4·5 μ wide, constituting the *proximal* or *first convoluted tubule*. It becomes continuous with the *spiral tubule* of Schachowa (4), which lies in a medullary ray, where it pursues a slightly wavy or spiral course.

On the boundary line, between the cortical and boundary zone, the spiral tubule suddenly becomes smaller (Isaacs) and passes into the *descending portion of Henle's loop* (5), which is 14 μ in breadth, and is continued downwards through the boundary zone into the medulla, where it forms the narrow *loop of Henle* (6), which runs backwards in the medullary part to the boundary zone. Here it becomes wider (20–26 μ), and as it continues its undulating course, it enters a medullary ray, where it constitutes the *ascending loop-tube* (7), which becomes narrower in the cortex. Leaving the medullary ray again, it passes into the labyrinth, where it forms a tube with irregular angular outlines—the *irregular tubule* (10), which is continuous with (Fig. 180, *n, n*) the *second* or *distal convoluted tubule* or *intercalated tubule* ("Schaltstück" of Schweigger-Seidel) (11), which resembles the proximal tubule of the same name.

Its diameter is $40\ \mu$. A short, narrow, wavy *junctional* or *curved collecting tubule* (12) connects the latter with one of the *straight collecting tubes*

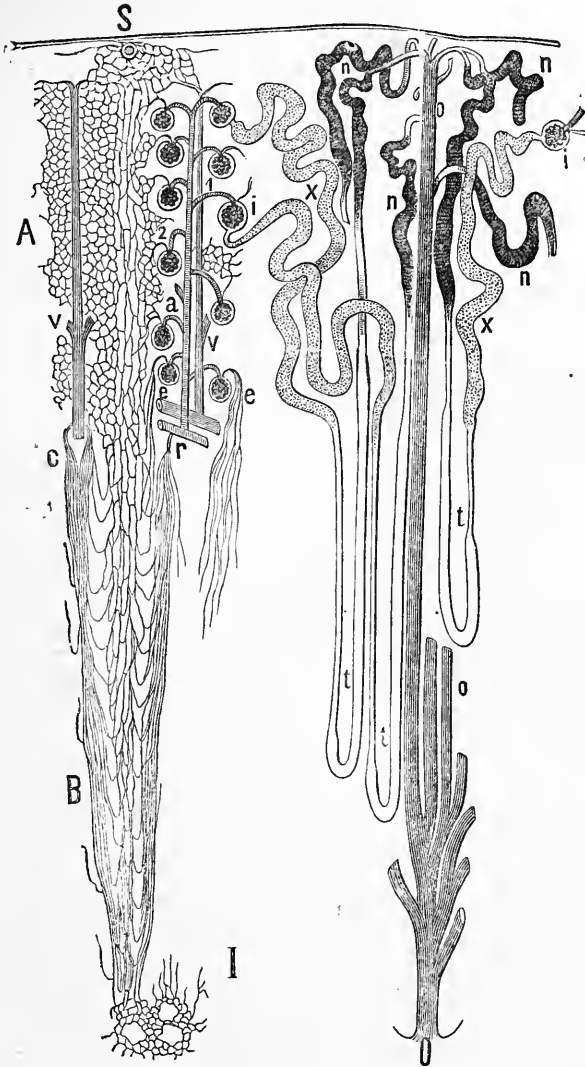

Fig. 180.

Structure of the kidney—I, the blood-vessels and uriniferous tubules shown in a semi-diagrammatic manner; A, capillaries of the cortex; B, capillaries of the medulla; a, interlobular artery; l, vas afferens; 2, vas efferens; r, e, vasa recta; c, venae rectae; v, v, interlobular vein; S, commencement of a vena stellata; i, i, Bowman's capsule enclosing a glomerulus; X, X, convoluted tubules; t, t, Henle's loop; n, n, junctional piece; o, o, collecting tubes; O, excretory tube.

(13) of a medullary ray. As the collecting tubule proceeds towards the boundary zone, it receives numerous junctional tubes, and when it reaches the boundary zone, it forms one of the *collecting tubes* (Fig. 180, O), which unite with one another at acute angles to form the larger straight *excretory tubes* or ducts of Bellini (15), which open on the summit of the Malpighian pyramids into a calix of the pelvis of the kidney. In the cortex the collecting tubules are $45\ \mu$ in diameter, but where they have formed an excretory tube (O), their diameter is $200\text{--}300\ \mu$; 24–80 of these tubes (Paul Müller) open on the apex of each of the 12–15 Malpighian pyramids. In the lowest and broadest part, the *membrana propria* is strengthened by the presence of a thick supporting framework of connective-tissue.

Structure of the Tubules.—[Below the neck, the tubules are lined everywhere by a *single* layer of nucleated epithelium.] *Bowman's capsule*, which is about $\frac{1}{250}$ inch in diameter (Fig. 181, II), consists of a homogeneous basement membrane lined internally by a single continuous layer of flattened cells (*k*). According to Roth, the basement

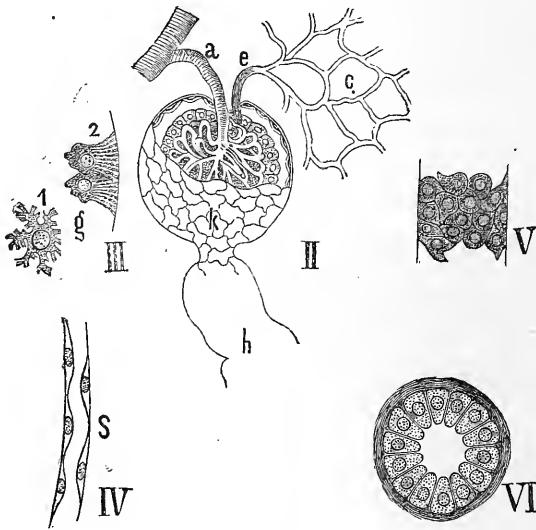

Fig. 181.

Structure of the kidney.—II, Bowman's capsule and glomerulus—*a*, vas afferens; *e*, vas efferens; *c*, capillary net-work of the cortex; *k*, endothelial structure of the capsule; *h*, origin of a convoluted tubule.—III, "rodged" or "fibrillated" cells from a convoluted tubule—2, seen from the side, with *g*, inner granular zone; 1, from the surface.—IV, cells lining Henle's looped tubule.—V, cells of a collecting tube.—VI, section of an excretory tube.

membrane itself is composed of endothelial cells. [In the foetus the lining cells are more polyhedral.] Within the capsule lies the glomeru-

lus or tuft of blood-vessels (p. 522). The cells lining the capsule are reflected over and between the lobules of which the glomerulus consists. The glomerulus may not completely fill the capsule, so that, according to the activity of the kidney, there may be a larger or smaller space between the glomerulus and the capsule into which the filtered urine passes. The *neck* is lined by cubical cells. These cells, in some animals, e.g., the rabbit, sheep (Hassal), mouse (Klein), and frog, are ciliated.

The *proximal convoluted tubule* is lined by characteristic epithelium. The cells, which are short or polyhedral, form a single layer, with a turbid or cloudy protoplasm (Fig. 181, III, 1 and 2), which not unfrequently contains oil-globules. The cells consist of two parts; the inner containing the spherical nucleus is next the lumen, and granular (III, 2, *g*), while the outer part, next the *membrana propria*, appears fibrillated, or "rodged" (Heidenhain), from the presence of rods (*Stübchen*), or fibrils placed vertically to the basement membrane (Fig. 182). These appear like the hairs of a brush pressed upon a plate of glass (III, 2). The cells are not easily separated from each other, as neighbouring cells interlock by means of the branched ridges on their surfaces (III, 1)—(R. Heidenhain, Schachowa). The lumen is well defined, but its size seems to depend upon the state of imbibition of the cells bounding it.

The *spiral tubule* has similar epithelium and a corresponding lumen, although the epithelium becomes lower and somewhat altered in its characters at the lower part of the tube.

The *descending limb of Henle's loop*, and the loop itself with a relatively wide lumen, are bounded by clear, flattened epithelial cells, with a bulging nucleus (IV, S); the cells lying on one side of the tube being so placed that the bulging part of the bodies of the cells is opposite the thin part of the cells on the opposite side of the tube. [These tubes might be mistaken for blood-capillaries, but in addition to their squamous lining, they have a basement membrane, which capillaries have not.] In the *ascending limb*, the lumen is relatively wide, while its epithelium agrees generally with that in the convoluted tubule, excepting that the "rods" are shorter. Sometimes the cells are arranged in an "imbricate" manner.

In the *irregular tubule*, which has a very small lumen, the polyhedral

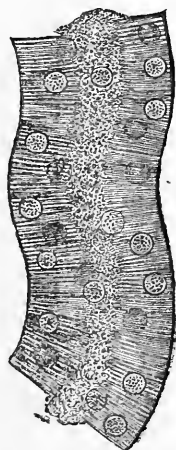

Fig. 182.

Convoluted tubule after the action of ammonium chromate, showing peculiar "rodged" epithelium (Heidenhain).

cells lining it contain oval nuclei, and are shorter than those of the convoluted tubules. The cells, again, are very irregular in size, while their "rodged" character is much coarser and more defined (Fig. 183).

The *distal convoluted tubule* closely resembles in its structure the proximal convoluted tubule, and is lined by similar cells. The *curved collecting*, or *junctional tubule*, although narrow, has a relatively wide lumen, as it is lined by clear, somewhat flattened cells.



Fig. 183.

Epithelium of the irregular tubule of the kidney of a dog (Tyson, after Klein).

The *collecting tubes* have a distinct lumen, and are lined by *clear*, somewhat irregular cubical cells (Fig. 181, V), which in the larger *excretory tubes* are distinctly columnar (VI). The basement membrane is said to be absent in the larger tubes.

[Klein describes a thin, delicate, nucleated centro-tubular membrane lining the surface of the epithelium next the lumen.]

The Blood-Vessels.—The renal artery (Fig. 177) divides into four or five branches, which pass into the kidney at the hilum. These branches, surrounded by connective-tissue, continuous with that of the capsule, continue to divide, and pass between the papillæ, to reach the bases of the pyramids on the limits between the cortical and boundary zones, where they form incomplete arches. From these horizontal trunks, the *interlobular arteries* (Fig. 180, a), run vertically and singly into the cortex, between each two medullary rays, and in their course they give off on all sides the short undivided *vasa afferentia* (1), each of which enters a Malpighian capsule at the opposite pole from which the urinary tubule is given off. Within the capsule, each afferent artery breaks up into capillaries arranged in lobules and supported by connective-tissue, the whole forming a tuft of capillary blood-vessels, or a *glomerulus*. Each glomerulus is covered on its surface, directed towards the wall of the capsule, by a layer of flat, nucleated epithelial cells (Fig. 181, II), which also dip down between the capillaries (Heidenhain, Runeberg). A vein, the *vas efferens* (2), which is always smaller than the afferent arteriole, proceeds from the centre of the glomerulus, and leaves the capsule close to the point at which the afferent vessel enters it (Fig. 181, II). In their structure and distribution, all the efferent vessels resemble arteries, as they divide into branches to form a dense, narrow meshed *capillary net-work* (Fig. 180, A, and Fig. 181, II, c), which surrounds and ramifies over the convoluted tubules. The meshes are elongated

around the tubules of the medullary rays, and more polygonal (Fig. 180) around the convoluted tubules. Some of the lowest efferent vessels split up into vasa recta, which run towards the medulla. The interlobular arteries become smaller as they pass towards the surface of the kidney, and some of their terminal capillaries communicate with the capillaries of the external capsule itself.] Venous trunks proceed from the capillary net-work, to terminate in the *interlobular veins* (V). These veins begin close under the external capsule by venous radicles arranged in a stellate manner (constituting the stellulae Verheyinii, or *venae stellatae*), and accompany the corresponding artery to the limit between the cortex and boundary zone, where they communicate with the large venous trunks in that situation.

The **blood-vessels of the medulla** arise from the *vasa recta* (Fig. 180, r). The latter begin on the limit of the cortex and medulla, either as single, direct, muscular branches (r) of the large arterial trunks, or from those efferent vessels (e) which lie next to the medulla. The latter are said to be devoid of muscle; while, according to Huschke, a few vasa recta are formed by the union of the capillaries of the medullary rays. All the vasa recta enter the boundary layer, where they split up into a leash or pencil of small arterioles, which pass between the straight tubules towards the pelvis, and form in their course a capillary net-work with elongated meshes. From these capillaries there arise venous radicles, which, as they proceed towards the limit between the cortex and medulla, form the *venae rectae* (e), and open into the concave side of the venous trunks in this region. At the apex of the papillae, the capillaries of the medulla form connections with the rosette-like capillaries surrounding the excretory ducts (at I). [The circulation through the vasa recta is most important. The cortical system of blood-vessels communicates with the medullary, but as most of the vasa recta are derived from the same vessel as the interlobular arteries, it is evident that they may form a side-stream through which much of the blood may pass without traversing the vessels of the cortex. Very probably the "short-cut" is useful in congestions of the kidney. The amount of distension of these vessels also will influence the size of the tubules lying between them. There are two other channels by which blood can pass through the renal arteries without traversing the glomeruli—(1) The anastomoses between the terminal twigs of the renal artery and the sub-capsular venous plexus; (2) small branches given off, either by the interlobular arteries, or by the afferent vessels before entering the glomeruli (Brunton).]

The **blood-vessels of the external capsule** are derived partly from the terminal twigs of the interlobular arteries, partly from branches of the supra-renal,

phrenic, and lumbar arteries, which anastomose with each other. The capillary net-work has simple meshes. The origins of the veins pass partly into the venæ stellatæ, and partly into the veins of the same name as the arteries. The connection of the area of the renal artery with the other arteries of the capsule explains why, after ligation of the renal artery within the kidney, the blood still circulates in the external capsule (C. Ludwig, M. Herrmann); in fact, these blood-vessels still supply the kidney with a small amount of blood, which may suffice to permit a slight secretion of urine to take place (Litten, Pautynski).

III. The lymphatics form a wide-meshed plexus in the capsule of the kidney, while under it they form large spaces (Heidenhain). In the parenchyma of the kidney, the lymphatics are said to be represented by large slits devoid of a wall in the tissues, and are more numerous around the convoluted than the straight tubules. The slits pass to the surface of the kidney, and expand under the capsule. When the lymphatics are greatly distended, they tend to compress the uriniferous tubules and the blood-vessels (C. Ludwig and Zawarykin). According to Ryndowsky, the uriniferous tubules are surrounded by true lymphatics with an endothelial lining, and they even penetrate into the capsule of Bowman along with the vas afferens. [The large blood-vessels are also surrounded by lymphatics.] Large lymphatics, provided with valves, pass out of the kidney at the hilum, while others emerge through the capsule; both sets are connected with the lymph-spaces of the capsule of the kidney (A. Budge).

IV. The nerves form small trunks provided with *ganglia* [Beale], and accompany the blood-vessels. [They are derived from the renal plexus and the lesser splanchnic nerve.] They contain medullated and non-medullated fibres, and the latter have been traced by W. Krause as far as the apices of the papillæ. Their mode of termination is unknown. *Physiologically*, we are certain that they contain both *vaso-motor* and *sensory* fibres; perhaps there may be also vasodilator and secretory fibres.

The connective-tissue, or intertubular stroma, forms in the papillæ, especially at their apices, fibrous, concentric layers of considerable thickness between the excretory tubules (Fig. 181, VI). Further outwards, the fibrillar character becomes less distinct, while at the same time branched connective-tissue corpuscles occur in greater numbers (Beer). In the cortex, the interstitial stroma consists almost entirely of branched corpuscles, which anastomose with each other (Goodsir). [There is also a small quantity of delicate fibrous tissue around Bowman's capsule, and along the course of the arteries. The connective-tissue often plays an important rôle in pathological conditions of the kidney, as in interstitial nephritis.]

The outer layers of the capsule of the kidney are composed of dense bundles of fibrous tissue, while the deeper layers are more loose, and send processes into the cortical layers. The deeper layers also contain non-striped muscular fibres (Eberth, W. Krause). The *fat* surrounding the kidney is united to the kidney partly by blood-vessels and partly by bands of connective-tissue.

[The sub-capsular layer of the cortex and a thin layer next the boundary zone (Fig. 179, *a, a*) are devoid of Malpighian corpuscles.]

255. The Urine.

I. Physical Characters of the Urine.

A knowledge of the composition of this secretion is of the greatest value to the physician and surgeon.

1. The **quantity** of urine passed by an adult man in 24 hours is between 1,000 and 1,500 cubic centimetres, or about 50 ozs., and in the female 900–1,200 c.c. The minimum is secreted between 2–4 A.M., and the maximum between 2–4 P.M. (Weigelin).

The amount is **diminished** by profuse sweating, diarrhœa, thirst, non-nitrogenous food, diminution of the general blood-pressure, after severe hæmorrhage, and in certain diseases of the kidneys. The minimum, which may be normal, is 400–500 c.c.

It is **increased** by increase of the general blood-pressure, or of the pressure within the area of the renal artery, by copious drinking, contraction of the cutaneous vessels through the action of cold, the passage of a large amount of soluble substances (urea, salts, and sugar) into the urine, a large amount of nitrogenous food, as well as by various drugs, such as digitalis, alcohol, squills. After taking fluids charged with CO_2 , the amount of urine is increased during the following hours (Quincke).

The secretion is influenced directly by the *nervous system*, as in the sudden polyuria following nervous excitement, such as hysteria, [when the person usually passes a large amount of very pale-coloured urine]; after an epileptic attack and also after pleasurable excitement (Beneke). Lastly, we have the polyuria unaccompanied by the presence of sugar in the urine, which follows injury to a certain part of the floor of the fourth ventricle (Cl. Bernard). The urine is measured in tall graduated cylindrical vessels (Fig. 184). [In estimating the quantity of urine passed, the patient must, of course, be directed always to empty his bladder at a particular hour, and collect the urine passed during the next 24 hours.]

2. The **specific gravity** varies, as a mean, between 1,015 and 1,025; the minimum, after copious draughts of water, may be 1,002; while the maximum, after profuse perspiration and great thirst, may be 1,040. The mean specific gravity is about 1,020. In newly-born children, the specific gravity falls very considerably during the first three days, which is due to the ingestion of a large amount of food (Martin and Ruge). [The specific gravity of the urine in infants is about 1,003–1,006.] A healthy adult excretes about 50 grams. [$1\frac{1}{2}$ oz.] daily of solids by the urine.

The **specific gravity** is estimated by means of a urinometer (Fig. 185), the urine being at the temperature of 16°C . [The urinometer, when placed in distilled water, ought to float at the mark 0° or zero, which is conventionally spoken of as 1,000. The urine itself ought to be tested in a tall cylindrical glass, of such width that the urinometer, when placed in it, may float freely and not touch the sides. Take care that no air-bubbles adhere to the instrument. When reading off the mark on the stem, raise the vessel to the eye and bring the eye on

a level with the surface of the water, noting the number which corresponds to this. This rule is adopted, because the water rises on the stem in virtue of capillarity. It is essential that a sample of the *mixed* urine of the twenty-four hours be used for ascertaining the mean specific gravity.]

Christison's Formula.—To estimate the amount of solids in the urine. This may be done approximately by means of the formula of Trapp or Haeser, or, as it is called in this country, "Christison's formula," viz., "Multiply the two last figures of a specific gravity expressed in four figures by 2.33" (Christison and Haeser), or by 2 (Trapp), or 2.2 (Loebisch). This gives the amount of solids in every 1,000 parts. [Suppose a person passes 1,200 c.c. urine in twenty-four hours, and the specific gravity is 1,022, then

$$22 \times 2.33 = 51.26 \text{ grms. in 1,000 c.c.}$$

To ascertain the amount in 1,200 c.c.

$$1,000 : 1,200 :: 51.26 : x = \frac{51.26 \times 1,200}{1,000} = 61.51 \text{ grms.}]$$

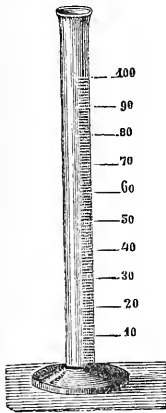

Fig. 184.

Graduated cylinder and flask for measuring the amount of urine.

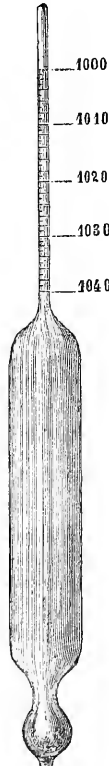

Fig. 185.

Urinometer.

Direct estimation to determine the exact amount of solids. Place 15 c.c. of urine in a capsule of known weight, and evaporate it over a water-bath, afterwards completely dry the residue in an air-bath at 100°C., and then cool it over concentrated sulphuric acid. During the process, a small amount of urea is decomposed, so that the value obtained is slightly too small. Of course, the specific gravity varies with the amount of water in the urine. The *most concentrated* (highest specific gravity) urine is the morning urine (*Urina noctis*), especially after being retained in the bladder—*e.g.*, in prolonged sleep a certain amount of water is absorbed, so that the urine becomes more concentrated. The most dilute urine is secreted after copious drinking (*Urina potus*). Under *pathological conditions*, as in diabetes mellitus (§ 175), the urine is, at the same time, very copious (as much as 10,000 c.c.), and very concentrated, while the specific gravity varies from 1,030–1,060. [The high specific gravity in this case is due to the presence of a large amount of grape-sugar.] In fever the urine is concentrated, and small in amount. Polyuria, due to certain nervous conditions, is character-

ised by a very dilute and very copious secretion of urine, and the specific gravity may be as low as 1,001.

[AMOUNTS OF THE SEVERAL URINARY CONSTITUENTS.]

CONSTITUENTS.	KERNER.			J. VOGEL.
	Man, 28 years of age, weight 72 kilos., observations over 8 days.			Mean of analyses in different individuals.
	In 24 hours.			
	Minimum.	Maximum.	Mean.	In 24 hours.
	c.c.	c.c.	c.c.	c.c.
Quantity,	1099	2150	1491	1500
Specific Gravity,	1015	1027	1021	1020
Water,	1440
Solids,	60
Urea,	32·00	43·4	38·1	35
Uric Acid,	0·69	1·37	0·94	0·75
Sodium Chloride,	15·00	19·20	16·8	16·5
Phosphoric Acid,	3·00	4·07	3·42	3·5
Sulphuric Acid,	2·26	2·84	2·48	2·0
Phosphorus, Calcium,	0·25	0·51	0·38	...
Magnesium Phosphate,	0·67	1·29	0·97	...
Total quantity of Earthy } Phosphates, }	0·92	1·80	1·35	1·2
Ammonia,	0·74	1·01	0·83	0·65
Free Acid,	1·74	2·20	1·95	3·

(After Loebisch.)]

[AMOUNTS OF THE SEVERAL URINARY CONSTITUENTS PASSED IN 24 HOURS.]

	By an average Man of 66 Kilos.	Per 1 Kilo. of Body-weight.
	Grammes.	Grammes.
Water,	1500·000	23·000
Total Solids,	72·000	1·100
Urea,	33·180	0·500
Uric Acid,	0·555	0·0084
Hippuric Acid,	0·400	0·0060
Kreatinin,	0·910	0·0140
Pigment and other Substances,	10·000	0·1510
Sulphuric Acid,	2·012	0·0305
Phosphoric Acid,	3·164	0·0486
Chlorine,	7·000 (8·12)	0·1260
Ammonia,	0·770	...
Potassium,	2·500	...
Sodium,	11·090	...
Calcium,	0·260	...
Magnesium,	0·207	...

(After Parkes.)]

The colour of the urine depends on the colouring matters present in it, and varies greatly, but the differences in colour are due chiefly to variations in the amount of water. Normally it has a pale straw

colour, but if it contains more water than usual it has a very pale tint, and in certain cases (as in the sudden polyuria occurring after an attack of hysteria), it may be as clear as water. Concentrated urine, as after

meals, or the first urine passed in the morning, has a darker colour; it is dark yellow or brownish-red; while it is usually dark coloured in fever.

Fœtal urine, and also the urine first passed after birth, are as clear and colourless as water. The admixture of various substances with the urine alters its colour. When mixed with *blood*, according to the degree of decomposition of the hæmoglobin, the urine is red or dark-brownish red [more frequently it is *smoky*], especially if the blood comes from the kidneys and the urine is acid. When mixed with *bile-pigments*, it is of a deep yellowish-brown, with an intense yellow froth; senna taken internally makes it intensely red, rhubarb brownish-yellow, and carbolic acid black. Urine undergoing the ammoniacal fermentation may present a dirty bluish appearance owing to the formation of indigo. [I have seen a peculiar blue colour, produced by putrefaction, in the urine obtained from a rabbit poisoned with carbolic acid.—W. Stirling.] The colour of urine is estimated by Neubauer and Vogel by means of an empirical "colour-scale."

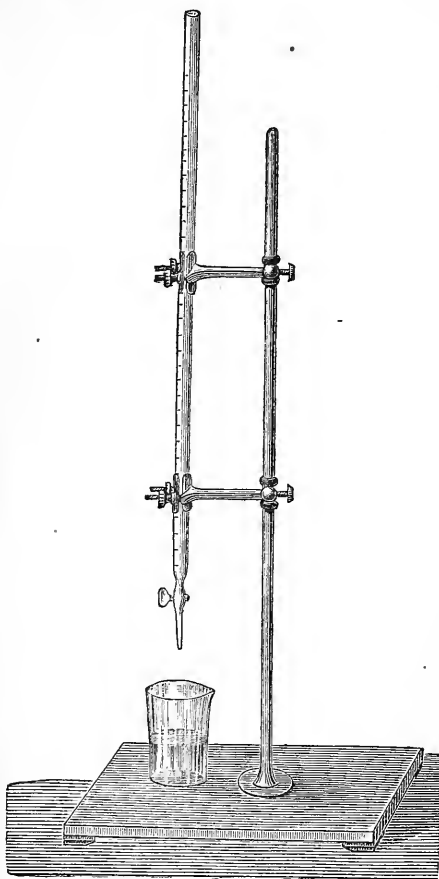

Fig. 186.

Graduated burette.

Fluorescence.—Urine, but especially ammoniacal urine, exhibits fluorescence, which disappears on the addition of an acid, and reappears after the addition of an alkali (Schönbein, Schleiss, v. Löwenfeld).

Mucous cloud.—Normal urine, after standing for several hours, deposits a fine cloud of vesical mucus [like delicate cotton wool]. The froth of normal urine is white, and disappears pretty rapidly, while that on an albuminous urine persists much longer. The urine not unfrequently contains some *epithelial cells* from the bladder and urethra.

Consistence.—Normal urine, like water, is a freely mobile fluid.

Large quantities of sugar, albumin, or mucus make it less mobile; while the so-called chylous urine of warm climates may be like a white jelly.

The **taste** is a saline bitter, the **odour** is characteristic and aromatic.

Ammoniacal urine has the odour of ammonia. Turpentine taken internally gives rise to the odour of violets, copaiba and cubeba a strongly aromatic, and asparagus an unpleasant odour. Valerian, assafœtida, and castoreum [but not camphor] also produce a characteristic odour. [The odour of diabetic urine is described as "sweet."]

The **reaction** of normal urine is acid, owing to the presence of acid salts, chiefly *acid sodic phosphate*, which seems to be derived from basic sodic phosphate, owing to the uric acid, hippuric acid, sulphuric acid and CO_2 taking to themselves part of the soda, so that the phosphoric acid forms an acid salt. After a diet of flesh, acid potassic phosphate is the cause of the acidity. That the urine contains no free acid is proved by the fact that it gives no precipitate with sodic hyposulphite (v. Voit, Huppert).

The acid reaction is *increased* after the use of acids, e.g., hydrochloric and phosphoric, also by ammoniacal salts, which are changed within the body into nitric acid; lastly, after prolonged muscular exertion (Klüpfel, Fustier). The morning urine is strongly acid.

The urine becomes *less acid or alkaline*—(1) By the use of caustic alkalis, alkaline carbonates, or alkaline salts of the vegetable acids, the last being oxidised within the body into carbonates. (2) By the presence of calcic, or magnesian carbonate. (3) By admixture with alkaline blood, or pus. (4) By removing the gastric juice through a gastric fistula (p. 330—Maly); further, from 1-3 hours after a meal. [The reaction of urine passed during digestion may be neutral, or even alkaline. This is due either to the formation of acid in the stomach (Bence Jones), or to a fixed alkali derived from the basic alkaline phosphates taken with the food (W. Roberts).] (5) The urine is rarely alkaline in anæmia, owing to a deficiency of phosphoric and sulphuric acids. [(6) *The nature of the food*—vegetable food makes it alkaline.]

Method.—[The reaction of urine is tested by means of litmus paper. Normal urine turns blue litmus paper red, and does not affect red litmus. An alkaline urine makes red litmus paper blue, while a neutral urine does not alter either blue or red litmus paper.] Sometimes *violet* litmus paper is used, which becomes red in acid, and blue in alkaline urine.

Estimation of the Acidity.—This is done by determining the amount of caustic soda necessary to produce a neutral reaction in 100 c.c. of urine. A soda solution, containing 0.0031 grm. of soda in each c.c. is used; 1 c.c. of this solution exactly neutralises 0.0063 grm. oxalic acid. To the 100 c.c. of urine in a beaker, soda solution is added, drop by drop, from a graduated burette (Fig. 186), until violet litmus paper becomes neither red nor blue. The number of c.c. of soda solution is now read off on the burette, and as each c.c. corresponds to 0.0063 grm. oxalic acid, we can easily calculate the amount of oxalic acid, which is equivalent to the degree of acidity in 100 c.c. of urine. So that the degree of acidity of the urine is expressed by the equivalent amount of oxalic acid, which is completely neutralised by the same amount of caustic soda.

Urine of Mammals.—The urine of *carnivora* is pale, passing into a golden yellow; its specific gravity is high, and its reaction strongly acid. The urine of *herbivora* is alkaline; it shows a precipitate of earthy carbonates (hence, it effervesces on the addition of an acid), and of basic earthy phosphates. During hunger, the urine presents the character of that of *carnivora*, as the animal in this case practically lives upon its own flesh and tissues.

The Organic Constituents of Urine.

256. Urea = $\text{CO}(\text{NH}_2)_2$.

Urea, the diamide of CO_2 , or carbamide is the chief end-product of the oxidation of the nitrogenous constituents of the body. Its composition is comparatively simple: 1 carbonic acid + 2 ammonia - 1 water. It crystallises in silky four-sided prisms with oblique ends (rhombic system), without water of crystallisation (Fig. 187, *a*), but when it crystallises rapidly it forms delicate white needles. It has no action on

litmus, is odourless, and has a weak, bitter, cooling taste, like saltpetre; is readily soluble in water and alcohol, but insoluble in ether.

It is an isomer of ammonic cyanate, from which it may be prepared by evaporation (Wöhler, 1828), whereby the atoms rearrange themselves. It can be prepared artificially in many other ways.

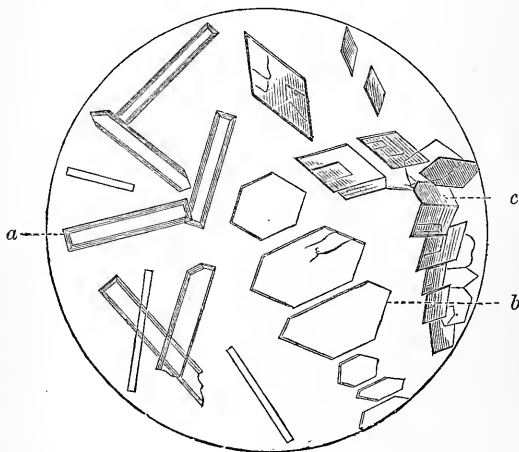

Fig. 187.

a, Urea; *b*, hexagonal plates, and *c*, smaller scales, or rhombic plates of urea nitrate.

Decomposition.—When heated above 120° , it gives off ammonia vapour, while a glassy mass of biuret and cyanic acid is left. When urine undergoes the alkaline fermentation (§263), or when urea is treated with strong mineral acids, or boiled with the hydrates of the alkalis, or super-heated with water (240°C .), it takes up two molecules of water and produces ammonium carbonate, thus—



When brought into relation with nitrous acid, it splits up into water, CO_2 , and N . The two last decompositions are made the basis of methods for the quantitative estimation of urea (p. 533).

Quantity.—In normal urine, urea occurs to the extent of 2.5 to 3.2 per cent. An adult man excretes daily from 30 to 40 grms.

[500 grains, or a little over 1 oz.]; women excrete less, while children excrete relatively more; owing to the relatively greater metabolism in children, the unit weight of body produces more urea than the unit weight of an adult in the proportion of 1·7 : 1. If the metabolism of the body is in a condition of equilibrium (§ 236), the urea excreted contains almost as much N, as is taken in with the nitrogenous constituents of the food.

Variations in the Quantity.—The amount of urea increases when the amount of proteids in the food is increased; and also when there is a more rapid breaking up of the nitrogenous tissues of the body itself. As this breaking up is increased by diminution of O (Fränkel, Penzoldt and Fleischer), and by loss of blood (Bauer); so these conditions also increase the urea (§ 41). It is also increased by drinking large draughts of water, by various salts, by frequent urination, and by exposure to compressed air. In diabetic persons, who eat very large quantities of food, it may exceed 100 grms. [over 3 ozs.] per day; during hunger, it sinks to 6·1 grms. [90 grains] per day (Seegen). During inanition, the maximum amount is excreted towards mid-day, and the minimum in the morning. The daily amount of urea varies with the quantity of urine; three to five hours after a meal, the formation of urea is at a maximum, when it sinks and reaches its minimum during the night. *Muscular exercise*, as a rule, does not increase it (v. Voit, Fick and Wislicenus—§ 295), but only when deficiency of O, causing dyspnoea, occurs at the same time (Oppenheim).

Pathological.—In acute febrile inflammations and in fevers generally (§ 220, 3), the urea increases until the crisis is reached, and afterwards it diminishes (Vogel). After the fever has passed off, the amount excreted is often under the normal. In some cases of high fever, although the amount of urea formed is increased, it may not be excreted; there is a *retention of the urea* (Naunyn), while, later on, this may lead to an increased excretion. In *chronic diseases*, the amount depends largely upon the state of the nutrition, the metabolism, and also upon the degree of fever present. Degenerative changes in the liver, *e.g.*, due to poisoning with phosphorus, may be accompanied by diminished excretion of urea and increased excretion of ammonia (Stadelmann). It is increased in man by morphia, narcotin, narcein, papaverin, codein, thebain (Fubini), arsenic (Gäthgens), compounds of antimony, and small doses of phosphorus (Bauer), which favour the decomposition of proteids. Quinine diminishes it.

Occurrence.—Urea occurs in the blood (1 : 10,000), lymph, chyle (2 : 1,000), liver, lymph-glands, spleen, lungs, brain, eye, bile, saliva, amniotic fluid, and pathologically in sweat, *e.g.*, in cholera, in the vomit and sweat of uræmic patients, and in dropsical fluids. As yet it has not been definitely determined where urea is formed, but the liver and, perhaps, the lymph-glands, are organs where it is produced. Electrical stimulation of the liver through the skin causes an increase in the amount of urea eliminated. Extensive destruction

of the liver, as in marked fatty degeneration, *e.g.*, by phosphorus poisoning, enormously diminishes the amount.

Formation.—It is certain that it is the chief end-product of the metabolism of the proteids. Less oxidised products are uric acid, guanin, xanthin, hypoxanthin, alloxan, allantoin. Uric acid administered internally appears in the urine as urea; alloxan and hypoxanthin can be changed directly into urea.

During digestion, the proteids are converted into leucin, tyrosin, glycine, and asparaginic acid. If the amido-acids, glycine, leucin or asparaginic acid, or ammoniacal salts, be given to an animal, the amount of urea excreted is increased. As the molecule of the amido-acids contains only one atom of N, and the molecule of urea contains two of N, it is probable that urea may be formed *synthetically* from these acids. It is possible that the amido-acids meet with nitrogenous residues in the juices of the body, *e.g.*, carbamic acid or cyanic acid. The union of these may produce urea. According to Salkowski, feeding with these substances causes the breaking-up of the proper proteids of the body so as to provide the necessary components. Schmiedeberg is of opinion that urea is formed in the body from ammonia carbonate by the removal of water; and v. Schröder found that, when he passed blood, containing ammonia carbonate, through a fresh liver, the urea in the blood was greatly increased. Drechsel succeeded in producing urea at ordinary temperatures by the rapid alternating oxidation and reduction of a watery solution of ammonia carbamate. [We know that the greater part of the urea exists in the blood, and that the renal epithelium removes it from the blood. Although it is surmised that some of the proteid bodies named above, more especially leucin, and perhaps also kreatin, are the precursors of urea, yet we cannot say definitely how or where the transformation takes place. Perhaps this is effected in the liver, and it may be also in the spleen.]

Preparation.—Urea is readily prepared from dog's urine (especially after a diet of flesh) by evaporating it to a syrupy consistence, extracting it with alcohol, and again evaporating the filtrate to a syrupy consistence. The crystals which separate are washed with water to remove any extractives that may be mixed with them and dissolved in absolute alcohol. It is then filtered and allowed to crystallise slowly. Or, human urine may be evaporated to one-sixth of its volume and cooled to 0°, and excess of strong nitric acid added, which precipitates urea nitrate mixed with colouring matter. This precipitate is pressed in blotting-paper, then dissolved in boiling water containing animal charcoal and filtered while hot. When

it cools, colourless crystals of urea nitrate separate (Fig. 187, c). These crystals are redissolved in warm water, and barium carbonate added until effervescence ceases; urea and barium carbonate are formed. Evaporate to dryness, extract with absolute alcohol, filter, and allow evaporation to take place, when urea separates.

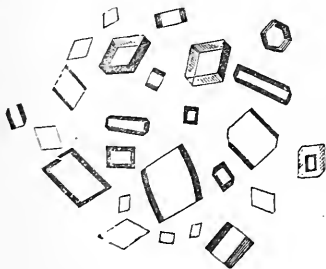

Fig. 188.

Perfect crystals of oxalate of urea.

Compounds of Urea.—Urea combines with acids, bases, and salts. The following are the most important combinations:—

1. **Urea nitrate** ($\text{CH}_4\text{N}_2\text{O}$, HNO_3) is easily soluble in water, and not so soluble in water containing nitric acid. It forms characteristic rhombic crystals (Fig. 187, b and c). Sometimes the formation of these crystals is used to determine *microscopically* the presence of urea in a fluid. If a fluid is suspected to contain

minute traces of urea, it is concentrated and a drop of the fluid is put on a microscopic slide. A thread is placed in the fluid, and the whole is covered with a cover-glass. A drop of concentrated nitric acid is allowed to flow under the cover-glass, and after a time crystals of urea nitrate adhering to the thread may be detected with the microscope.

2. **Urea oxalate** $(\text{CH}_4\text{N}_2\text{O})_2 \text{C}_2\text{H}_2\text{O}_4 + \text{H}_2\text{O}$ is, made by mixing a concentrated solution of urea with oxalic acid. The crystals form groups of rhombic tables, often of irregular shape. It is only slightly soluble in cold water, and still less so in alcohol (Fig. 188).

3. **Urea phosphate** $(\text{CH}_4\text{N}_2\text{O}, \text{H}_3\text{PO}_4)$, forms large, glancing, rhombic crystals, very easily soluble in water. It is obtained by evaporating the urine of pigs fed on dough.

4. **Sodic chloride + urea** $(\text{CH}_4\text{N}_2\text{O}, \text{NaCl} + \text{H}_2\text{O})$, forms rhombic, shining prisms, which are sometimes deposited in evaporated human urine.

5. **Urea + mercuric nitrate** is obtained as a white cheesy precipitate, when mercuric nitrate is added to a solution of urea. Liebig's titration method for urea depends on this reaction (§ 257, II.).

257. Qualitative and Quantitative Estimation of Urea.

I. **The Qualitative Estimation of Urea.**—(1.) *It may be isolated as such.* If *albumin* be present, add to the fluid three to four times its volume of alcohol, and, after several hours, filter. Evaporate the filtrate over a water-bath, and dissolve the residue in a few drops of water.

(2.) The crystals of urea nitrate may be detected microscopically (p. 530).

(3.) **Sodic hypobromite** breaks up urea into CO_2 , H_2O and N. On this reaction depends the Knop-Hüfner method of quantitative estimation. The N rises in the form of small bubbles in the mixed fluid, while the CO_2 is absorbed by the fluid. [The reaction is the following:—



The nitrogen is collected and estimated in a graduated tube, and the amount of urea calculated from the volume of nitrogen. A convenient apparatus for this purpose is that of Russell and West.]

II. **Quantitative Estimation of Urea in Urine by Liebig's Method.**—By means of a graduated pipette (Fig. 189), 40 cubic centimetres of the urine are taken up and placed in a beaker. To this is added 20 cubic centimetres of *barium-mixture* to precipitate the sulphuric and phosphoric acids. The barium-mixture consists of 1 vol. of a cold saturated solution of barium nitrate and 2 vols. of a cold saturated solution of barium hydrate. Filter through a *dry* filter, and take 15 cubic centimetres of the filtrate, *which correspond to 10 c.c. of urine*, and place in a beaker.

Allow a titrated standard solution of *mercuric nitrate* to drop from a burette into the urine until a precipitate no longer occurs. The mercuric nitrate



Fig. 189.
Graduated
pipette.

is made of such a strength that 1 cubic centimetre of it will combine with 10 milligrammes of urea. Test a drop of the mixture from time to time in a watch-glass with a solution of *sodic carbonate*, which is called the *indicator*. Whenever the slightest excess of mercuric nitrate is added, the mixture strikes a *yellow* colour with the soda. The standard solution must be added drop by drop until this result is obtained. Read off the number of cubic centimetres of the standard solution used; as each centimetre corresponds to 10 milligrammes of urea, just multiply by 10, and the amount of urea in 10 cubic centimetres of urine is obtained.

This method does not give quite accurate results even in normal urine. To urine containing much phosphates is added an equal volume of the barium-mixture. Very acid urines may require several volumes to be added. Urine containing albumin or blood must be boiled, after the addition of a few drops of acetic acid, to remove the albumin. The sodic chloride in the urine also interferes with the accuracy of the process.

258. Uric Acid = $C_5H_4N_4O_3$.

Formula and Quantity.—Uric acid [probably tetronyldicyanamid = $C_3H_2O_3(NH.CN)_2$] is the nitrogenous substance which, next to urea, carries off most of the N from the body. The quantity excreted in twenty-four hours is 0.5 gram. (7–10 grains); during hunger, 0.24 gram. (4 grains); after a strongly animal diet, 2.11 gram. (30–35 grains). The proportion of urea to uric acid is 45:1.

It is the chief nitrogenous product in the urine of birds, reptiles, and insects, while it is absent from herbivorous urine.

If a mammal be fed with uric acid, part of it becomes more highly oxidised into urea, while the oxalic acid in the urine is also increased (p. 540—v. Wöhler, v. Frerichs); in fowls, feeding with leucin, glycin, or asparaginic acid (v. Knieriem), or ammonia carbonate (Schröder), increases the amount of uric acid. When urea is administered to fowls, it is *reduced* chiefly to uric acid (Cech, H. Mayer, Jaffé).

Properties.—Uric acid is dibasic, colourless, and crystallises in various forms (Figs. 190 and 191), belonging to the *rhombic* system. When the angles are rounded, the *whetstone* form (*a*) is produced, and if the long surfaces be flattened, six-sided tables occur. Not unfrequently diabetic urine deposits spontaneously, large, yellow, transparent rosettes (*d*). If 20 c.c. of HCl, or acetic acid, be added to 1 litre of urine, crystals (*b*) are deposited, like cayenne-pepper, on the surface and sides of the glass, *after several hours*. [The crystals are deposited only after the urine has stood for several hours. The HCl decomposes the urates, and liberates the acid, which does not crystallise at once owing to the presence of the phosphates in the urine (Brücke). Crystals of

uric acid are usually yellowish in colour from the pigment of the urine, and they are soluble in caustic potash.]

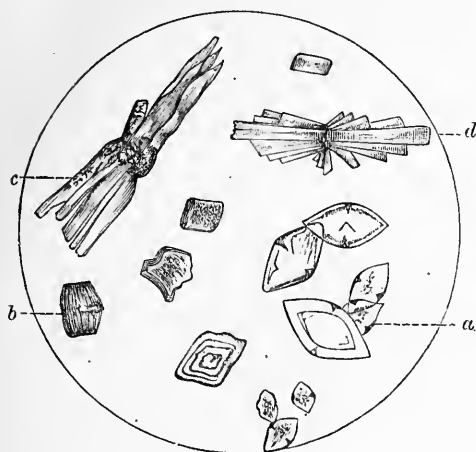

Fig. 190.

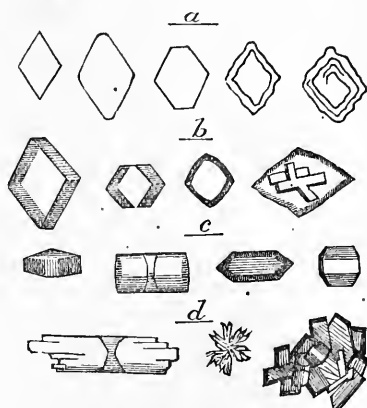

Fig. 191.

Fig. 190.—Uric acid—*a*, rhombic tables (whetstone form); *b*, barrel form; *c*, sheaves; *d*, rosettes of whetstone crystals.

Fig. 191.—Crystals of uric acid—*a*, rhomboidal, truncated, hexahedral, and laminated crystals; *b*, rhombic prism, horizontally truncated angles of the rhombic prism, imperfect rhombic prisms—on the last crystal in this row is placed a group of rectangular crystals; *c*, prism with a hexahedral basic surface, barrel-shaped figure, prism with a hexahedral basal surface; *d*, cylindrical figure, stellate and superimposed groups of crystals $\times 300$ (Wedl).

Solubility.—It is tasteless and odourless; reddens litmus; is soluble in 18,000 parts of cold, and in 15,000 of boiling water, and insoluble in alcohol and ether. Horbaczewski prepared it synthetically (1882) by melting together glycin, or, as it is also called, glycocin and urea.

It is freely soluble in alkaline carbonates, borates, phosphates, lactates, and acetates, these salts at the same time removing a part of the base; thus there is formed acid urates and acid salts from the neutral salts. It is soluble in concentrated sulphuric acid, from which it may be precipitated by the addition of water. During dry distillation it decomposes into urea, cyanuric acid, hydrocyanic acid, and ammonium carbonate. Superoxide of lead converts it into urea, allantoin, oxalic acid, and CO_2 ; while ozone forms the same substances, with the addition of alloxan. When it is reduced by H *in statu nascendi*, as by sodium amalgam, it forms xanthin and sarkin.

[Formation.]—It is a less oxidised metabolic product than urea, but it is by no means proved that uric acid is a precursor of urea. The older theory is that its formation is due to incomplete oxidation of proteid substances in the body. This view is partly founded on the fact that, uric acid can be split up into urea and other bodies by oxidation (nitric acid), thus—

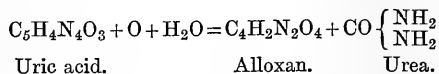

If alloxan be heated with baryta water, it is converted into mesoxalic acid and urea—

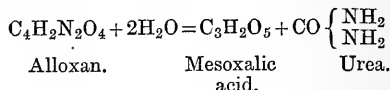

If uric acid is oxidised by lead dioxide it is changed as follows (Fownes) —

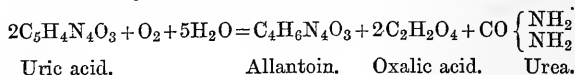

The defective oxidation theory was supposed to be supported by the fact that reptiles, whose respiratory processes are slow, excrete their nitrogenous products chiefly in the form of uric acid or its compounds. But birds with very rapid respiration, active metabolism, and a high temperature, also eliminate their nitrogen in the urine chiefly as uric acid. Nor does diet influence it much. The carnivorous lion and tiger excrete little uric acid and much urea, while the carnivorous python and boa excrete no urea, but only uric acid salts, and the same is the case with graminivorous birds. There is no doubt, however, that diet influences the amount of uric acid in the *same species* of animal (Latham). In herbivora, hippuric acid takes the place of uric acid in the urine. The uriniferous tubules of those animals that excrete uric acid are adapted to the elimination of a solid excrement, while the tubules of those that excrete urea are adapted to a fluid excrement. As stated above, Horbaczewski obtained uric acid by fusing together glycozin (amido-acetic acid) and ten times its weight of urea, at 200°–230°C., although Latham has not been able to confirm this observation. According to Latham, the antecedent of uric acid is glycozin, and the appearance of uric acid in the secretion of one animal and of urea in another is the result primarily of the non-transformation of glycozin into urea, and he attributes the primary defect in gout to a similar imperfect metabolism of glycozin either in the liver or elsewhere. Some observers assume that the precursors of both urea and uric acid contain some of their nitrogen in the form of cyanogen.]

Occurrence.—Uric acid occurs dissolved in the urine in the form of *acid urates of soda and potash*. These salts occur also in urinary calculi, gravel, and in gouty deposits. Ammonium urate occurs in very small quantity in a deposit of "urates," but is formed in considerable amount when urine becomes ammoniacal from decomposition (Fig. 198). *Free uric acid* occurs in normal urine only in the very smallest amount. It is sometimes deposited *after a time* (see *Acid fermentation*, Fig. 197). It frequently forms urinary calculi, being sometimes deposited around a speck of albumin as a nucleus (Ebstein). [It has also been found in the blood, liver, and spleen (p. 206). It is remarkable that it has been found in the spleen of herbivora, although, as stated above, it is absent from herbivorous urine. In gout, it accumulates in the blood (Garrod).]

The urine of newly-born children contains much uric acid. Uric acid and its salts are *increased* after severe muscular exertion, accompanied by perspiration, in

catarrhal and rheumatic fevers, and such conditions as are accompanied by disturbance of the respiration; in leukaemia and tumours of the spleen, cirrhotic liver, and generally in cases of catarrh of the stomach and intestinal tract, following the excessive use of alcohol. [It is also increased during ague and fevers, and perhaps this has some relation to the congestion of the spleen, which accompanies these conditions.]

It is *diminished* after copious draughts of water, after large doses of quinine, caffeine, potassic iodide, common salt, sodic and lithic carbonates, sodic sulphate, inhalation of O, slight muscular exertion. In gout, the amount excreted in the urine is small. In chronic tumours of the spleen, anaemia, and chlorosis, when the respiration is not at the same time embarrassed, it is also diminished.

Urates.—Uric acid forms salts—chiefly *acid* urates—with several bases, which dissolve with difficulty in cold water, but are easily soluble in warm water. Neutral urates are changed by CO_2 into acid salts. Hydrochloric and acetic acids break up the compounds, and crystals of uric acid separate.

(1.) *Acid sodic urate* usually appears as a brick-red deposit, more rarely gray or white (lateritious deposit), tinged with uroerythrin, in urine, in catarrhal conditions of the digestive organs, and in rheumatic and febrile affections. Microscopically, it is completely amorphous, consisting of granules, sometimes disposed in groups (Fig. 197, *b*)—sometimes the granules have spines on them. The corresponding potash salt occurs not unfrequently under the same conditions, and presents the same characters.

(2.) *Acid ammonium urate* (Fig. 198, *a*) always occurs as a sediment, in ammoniacal urine, either with (1), or mixed with free uric acid, accompanied by triple phosphate. Microscopically, it is the same as (1). (1) and (2) are distinguished by the sediment dissolving when the urine is heated. If a drop of hydrochloric acid be added to a microscopic preparation of the sediment, crystals of uric acid separate.

(3.) *Acid calcic urate* occurs sometimes in calculi, and is a white, amorphous powder, but slightly soluble in water. When heated on platinum it leaves an ash of calcium carbonate. Magnesia rarely occurs in urinary calculi.

259. Qualitative and Quantitative Estimation of Uric Acid.

I. Qualitative Estimation.

1. **Microscopic Characters.**—The appearances presented by uric acid and its salts under the microscope. It is deposited from urine after several hours, on adding acetic or hydrochloric acid.

2. **The Murexide Test.**—Gently heat a urate or uric acid in a porcelain vessel along with nitric acid. Decomposition takes place and the colour changes to yellow. N and CO_2 are given off; urea and alloxan ($\text{C}_4\text{H}_2\text{N}_2\text{O}_4$) remain. Evaporate slowly and allow the yellowish red stain to cool. The addition of a drop of dilute ammonia gives a

purplish red colour which is due to murexide. The purple colour becomes blue on the addition of caustic potash. If potash or soda be added instead of ammonia, a violet colour is obtained.

3. **Schiff's Test.**—If a little uric acid or a urate be dissolved in a solution of an alkaline carbonate, and this be dropped upon blotting-paper saturated with a solution of *silver nitrate*, reduction of the silver takes place at once, and a black spot is formed (H. Schiff).

4. On boiling a solution of uric acid or a urate in an alkali, with Fehling's solution (§ 149, 2), at first white urate of the suboxide of copper is deposited, while later, red copper suboxide is formed.

II. The **quantitative** estimation may be made by adding 5 cubic centimetres of concentrated HCl to 100 c.c. of urine, and allowing it to stand for 48 hours in the dark, when the uric acid is precipitated like fine cayenne-pepper crystals. Salkowski and Fokker have improved the method. All the uric acid is not precipitated by the HCl, even after standing for a time. [E. A. Cook uses sulphate of zinc to precipitate the uric acid as urate of zinc. Caustic soda is added to precipitate the phosphates, and then to the clear fluid zinc sulphate solution, which precipitates urate of zinc as a white gelatinous deposit.]

260. Kreatinin = $C_4H_7N_3O$, and other Substances.

Quantity.—Kreatinin (Liebig) is derived from the kreatin of muscle, from which it can be obtained by heating it in a watery solution, a molecule of water being given off; and, conversely, kreatinin may take up water and form kreatin. The amount excreted daily is 0.6–1.3 grammes (8–18 grains); it is increased by flesh diet.

It is *diminished* in progressive muscular atrophy, anæmia, marasmus, chlorosis, consumption, paralysis; and is *increased* in typhus, inflammation of the lung, and tetanus; it is not absent in hunger.

Properties.—Kreatinin is alkaline in reaction, easily soluble in water and hot alcohol. It occurs in the form of colourless oblique rhombic columns. It forms compounds with acids and salts, with silver nitrate, mercuric chloride, and especially with *zinc chloride*. Kreatinin-zinc chloride (Fig. 192) is used to detect its presence.

Test.—Add to urine a few drops of a slightly brownish solution of nitro-prusside of soda, and then weak caustic soda solution, which cause a burgundy-red colour, which soon disappears (Th. Weyl). When heated with acetic acid, the colour changes to green or blue (Sal-

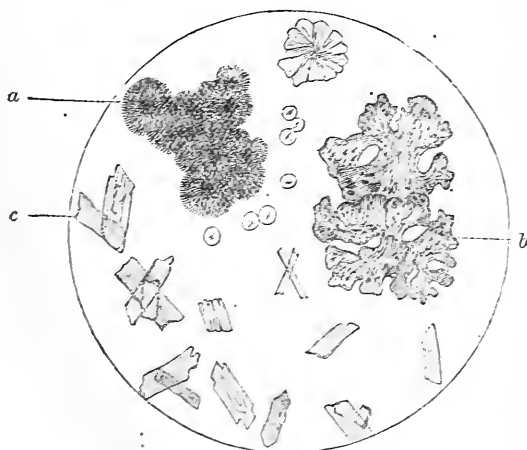

Fig. 192.

Kreatinin-zinc chloride—*a*, balls with radiating marks; *b*, crystallised from water; *c*, rarer forms from an alcoholic extract.

kowski). Kreatinin has been prepared artificially. When boiled with baryta water, it decomposes into urea and sarkosin. When administered by the mouth, or when injected into the blood, the greater part of it reappears unchanged in the urine.

Xanthin = $C_5H_4N_4O_2$ (Marcet) occurs in very small amount in the urine—1 gramme in 300 kilos. of urine. It is a substance intermediate between sarkin and uric acid. Guanin and hypoxanthin may be changed into xanthin; in contact with water and ferments it passes into uric acid. When evaporated with nitric acid, it gives a yellow stain, which becomes yellowish-red on adding potash, and violet-red on applying more heat. It is an amorphous, yellowish-white powder, fairly soluble in boiling water. It has also been found in traces in muscles, brain, liver, spleen, pancreas, and thymus.

The crystalline body **paraxanthin** occurs in traces in the urine (Salomon).

Guanin, $C_5H_5N_5O$, which occurs in guano and the urine of spiders, is changed into xanthin by nitrous acid; while feeding with it increases the amount of urea (Kerner). It has also been found by Virchow in the muscles of diseased pigs.

Sarkin (= Hypoxanthin), $C_5H_4N_4O$.—As yet this substance has been found only in the urine of leukæmic patients (Jakubasch), and it has been prepared in the form of needles or flattened scales (Scherer) from muscle, spleen, thymus, brain, bone, liver, and kidney. In *normal* urine a body nearly related to, and possibly identical with, hypoxanthin occurs (E. Salkowski). Hypoxanthin closely resembles xanthin, and can be changed into it by oxidation. Nascent hydrogen, on the other hand, reduces uric acid to xanthin and hypoxanthin. When evaporated with nitric acid it gives a light yellow stain, which becomes deeper, but not reddish-yellow, on adding caustic soda. It is more easily soluble in water than xanthin, and by this means the two substances can be separated from each other. Guanin is insoluble in water.

Oxaluric Acid ($C_3H_4N_2O_4$) occurs in *very small quantity* combined with ammonia in urine. Physiologically, it is interesting on account of its relation to uric acid. It is a white powder slightly soluble in water. Uric acid, when subjected to oxidising agents, takes up water, and splits into alloxan and urea—

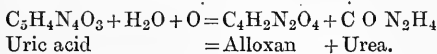

The alloxan, after taking up O, splits into CO_2 and parabanic acid; thus,

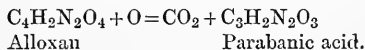

When parabanic acid takes up a molecule of water, oxaluric acid is formed, thus—

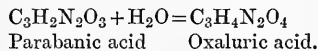

Lastly, when a solution of oxaluric acid is heated, it splits into oxalic acid and urea—

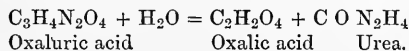

(Schunck.)

Oxalic Acid ($C_2H_2O_4$).—The series of chemical decompositions of oxaluric acid leads to oxalic acid. It occurs, but not constantly, to the amount of 20 milligrammes daily as *oxalate of lime*, which is known by the "envelope" shape of the crystals (Figs. 193 and 194); insoluble in acetic acid, and forming transparent octahedra: More rarely it assumes a biscuit or sand-glass form (Fig. 209, c). According to Neubauer, soluble oxalate of lime occurs in urine, being kept in solu-

tion by acid sodic phosphate. This substance is excreted in a crystalline form, the more the reaction of the urine becomes neutral.

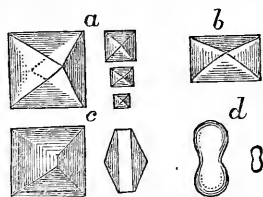

Fig. 193.

Crystals of oxalate of lime—*a*, Octahedra; *b*, basal plane of an octahedron forming a rectangle; *c*, compound forms; *d*, imperfect forms (dumb-bells) $\times 300$ (Wedl).



Fig. 194.

Perfect dumb-bell crystals of oxalate of lime from the urine of a child two years old suffering from jaundice (Beale).

The genetic relation of oxalic acid to uric acid is shown by the fact, that dogs fed with uric acid excrete much oxalate of lime (v. Frerichs, Wöhler). Oxalic acid may also be produced by the oxidation of products derived from the fatty acid series (p. 510).

Oxaluria.—The eating of substances containing oxalate of lime (rhubarb) increases the excretion. Increased excretion is called *oxaluria*: it is regarded as a sign of retarded metabolism (Beneke), and it may give rise to the formation of a calculus. In oxaluria the uric acid is also often increased in amount. Perhaps, in the first instance, there is an increased formation of uric acid, from which oxalic acid, urea, and CO_2 may be formed. The amount of oxalic acid is increased after the use of wine and sodic bicarbonate.

Hippuric Acid = $\text{C}_9\text{H}_9\text{NO}_3$ (Benzoylamidoacetic acid) occurs in large amount in the urine of herbivora (Liebig), and in them it replaces

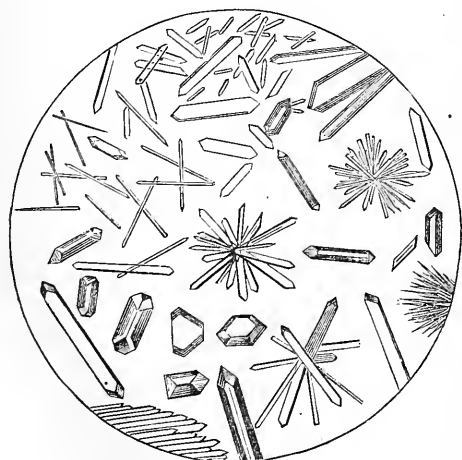
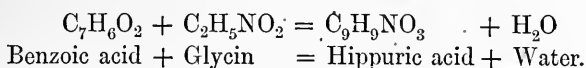

Fig. 195.
Hippuric Acid.

uric acid, and is one of the chief end-product of the metabolism of nitrogenous substances; in human urine the daily amount is small, 0.3–3.8 grms. (5–50 grains). It is an odourless monobasic acid with a bitter taste, and crystallises in colourless four-sided prisms. It is readily soluble in alcohol, and only soluble in 600 parts of water.

It is a conjugated acid, and is formed in the body from benzoic acid,

or some nearly related chemical body, such as the cuticular substance of plants, or from oil of bitter almonds, cinnamic or chinic acid, which easily pass by reduction (chinic acid) or by oxidation (cinnamic acid) into benzoic acid; glycin uniting with it, and water being given off—



[When benzoic acid is introduced into the alimentary canal of an animal (rabbit or dog), it appears in the urine as hippuric acid; while nitro-benzoic acid appears as nitro-hippuric acid. As the benzoic acid passes through the body it becomes conjugated with glycin or glycocin, chiefly in the kidneys. The hippuric acid in the urine of herbivora is chiefly derived from some substance with a benzoic acid residue present in the cuticular coverings of the food. That hippuric acid, in part at least, is formed in the kidneys is shown by the following considerations:—If arterialised blood, containing benzoic acid and glycin, or even benzoic acid alone, be passed through the blood-vessels of a fresh living excised kidney, hippuric acid is found in the blood after it is perfused. Even after forty-eight hours, if the kidney be kept cool, the synthesis takes place. If the kidney be kept too long, the conjugation does not take place. If the fresh kidney be chopped up, and kept at the temperature of the body with benzoic acid and glycin, hippuric acid is formed. Oxygen seems to be necessary for the process, for, if blood or serum containing carbonic-oxide be used, there is no formation of hippuric acid.]

According to this view, it is derived chiefly from the food of herbivorous animals, and hence it is absent from the urine of sucking calves. But it is also formed in the body from the proteids. In the dog, the formation of hippuric acid occurs in the kidney (Schmiedeberg and Bunge), and in the frog also outside the kidney. Kühne and Hallwachs thought it was formed in the liver, and Jaarsveld and Stockvis in the kidney, liver, and intestine. The observation of Salomon that, after excision of the kidneys in rabbits, and injection of benzoic acid into the blood, hippuric acid was found in the muscles, blood, and liver, goes to show that it must be formed in other organs beside the kidneys. The power of changing benzoic acid introduced into the human body, into hippuric acid, may even be abolished in disease of the kidney (Jaarsveld and Stockvis, Fr. Kronecker). Under certain circumstances it seems that hippuric acid, already formed, may be again decomposed in the tissues.

It is greatly increased after eating pears, plums, and cranberries; and it is also increased in icterus, some liver affections, and in diabetes. When boiled with strong acid or alkalis, or with putrid substances, it takes up H_2O and splits into benzoic acid and glycin. In the urine of the dog, in addition to uric acid, *cyanuric acid*, $\text{C}_{20}\text{H}_{14}\text{N}_2\text{O}_6 + \text{H}_2\text{O}$ (Liebig) is also present.

[**Preparation.**—Add milk of lime to the *fresh* urine of horses or cows to form calcic hippurate. Filter, evaporate the filtrate to a small bulk, and precipitate the hippuric acid with excess of hydrochloric acid. To purify the hippuric acid, crystallise it several times from a hot watery solution.]

[Crystals of hippuric acid when heated in a test-tube are decomposed, and a sublimate of benzoic acid and ammoniac benzoate condenses on the upper cool part of the tube, while there is an odour of new hay, and oily drops remain in the tube.]

Allantoin, $C_4H_6N_4O_3$, which occurs in the amniotic fluid of the cow, is found in minute traces in normal urine after flesh food, and is more abundant during the first weeks of life, and during pregnancy.

After large doses of tannic acid, the amount is increased (Schottin), while in dogs, feeding with uric acid also increases it (Salkowski).

Properties.—It forms shining, prismatic crystals; from the urine of sucking calves it crystallises in transparent prisms. It is decomposed by ferments into urea, ammonium oxalate, and carbonate, and another as yet unknown body. It is freely soluble in water, with difficulty in alcohol, and insoluble in ether. In preparing it, the urine is precipitated with basic lead acetate, the lead in the filtrate is removed by sulphuretted hydrogen, and the filtrate itself is then evaporated to a syrup, from which the crystals separate, after standing for several days. They are then washed with water, and recrystallised from that water (Salkowski). [It may be derived from uric acid by oxidation, and when it is further oxidised it forms urea (p. 536).]

261. Colouring-Matters of the Urine.

1. **Urobilin** (Jaffé) is most abundant in the highly coloured urine of fevers, but it also occurs in normal urine. It is a derivative of hæmatin, or of the *bile-pigments* (§ 177) derived from the latter. It is identical with the hydrobilirubin of Maly (p. 358). It gives a *red*, or *reddish-yellow* colour to urine, which becomes yellow on the addition of ammonia.

Preparation.—Prepare a chloroform extract of urine containing urobilin—add iodine to the extract, and remove the iodine by shaking the mixture with dilute caustic potash, which forms potassic iodide. This potash solution becomes yellow or brownish-yellow, and exhibits beautiful green *fluorescence* (Gerhardt).

Urobilin may be extracted from many urines by ether (Salkowski). When subjected to the action of reducing agents, *e.g.*, sodium amalgam, a colourless product is obtained, which on exposure to the air absorbs O, and becomes retransformed into urobilin. This colourless body is identical with the chromogen which Jaffé found in urine.

If urine is treated with soda or potash, the characteristic absorption band lying between *b* and *F*, passes nearer to *b*, becomes darker and more sharply defined. According to Hoppe-Seyler, urobilin is formed in urine after it is voided, from another urobilin-forming body (Jaffé's chromogen) absorbing oxygen. If urine containing urobilin be made alkaline with ammonia, and zinc chloride be added, it exhibits marked *fluorescence*; it has a *green shimmer* by reflected light. When urobilin is *isolated*, it fluoresces without the addition of zinc chloride. In cases of jaundice (§ 180), where Gmelin's test sometimes fails to reveal the presence of bile-pigments, urobilin occurs. This "urobilin-icterus" (Gerhardt) occurs chiefly after the absorption of large extravasations of blood. According to Cazeneuve, the urobilin is increased in all diseases where there is increased disintegration of coloured blood-corpuscles.

2. **Urochrome** (Thudichum) is regarded as the chief colouring-matter of urine. It may be isolated in the form of yellow scales, soluble in water, and in

dilute acids and alkalis. The watery solution oxidises, and when exposed to air becomes red, owing to the formation of *uroerythrin* (Thudichum). When acted on by acids, new decomposition products are formed, e.g., *wromelanin*. Uroerythrin gives the red colour to deposits of urates (§ 258).

In cases of melanotic tumours, there has been occasionally observed urine, which becomes dark, owing to *melanin* (§ 250, 4), or to a colouring-matter containing iron (Kunkel).

3. A brown pigment containing iron is carried down with uric acid, which is precipitated on the addition of hydrochloric acid (§ 258). By repeatedly adding sodic urate to the urine, and precipitating the uric acid by hydrochloric acid, a considerable amount may be obtained (Kunkel).

262. Indigo—Phenol—Kresol—Pyrokatechin—and Skatol-forming Substances.

Indican [$C_8H_7NSO_4$] or indigo-forming substance (Schunck), is derived from indol, C_8H_7N (Jaffé), the basis of indigo (Bayer), and is formed in the intestine by the pancreatic digestion of proteids (§ 170, II.), and it also arises as a putrefactive product (§ 184, 6). Indol, when united with the radical of sulphuric acid, HSO_3 , and combined with potassium, forms the so-called *indigogen* or *indican* of urine (Brieger, Baumann). This substance ($C_8H_6NSO_4K$ =indoxyl-sulphate of potash), forms white glancing tablets and plates; readily soluble in water and less so in alcohol. By oxidation it forms indigo-blue— $2 \text{ indican} + O_2 = C_{16}H_{12}N_2O_2$ (indigo-blue) + $2HKSO_4$ (acid potassic sulphate). It is more abundant in the urine in the tropics, and it is absent from the urine of the newly-born (Senator).

The indican in the urine is *increased* when much indol is formed in the intestine (§ 172, II.), e.g., in typhus, lead colic, trichinosis, catarrh, and hæmorrhage of the stomach, cholera, carcinoma of the liver and stomach; obstruction of the bowel or ileus, peritonitis and diseases of the small intestine—in cachexiæ, long standing suppuration, paraplegia—after taking creosote, oil of bitter almonds, turpentine, or nux vomica.

Tests.—Add to 40 drops of urine, 3–4 c.c. of strong fuming hydrochloric acid, and 2–3 drops of nitric acid. Boil, a *violet-red* colour with the deposition of true *crystalline* (rhombic); *indigo-blue* and *indigo-red* attests its presence. Putrefaction causes a similar decomposition in indican; hence, we not unfrequently observe a bluish-red pellicle of microscopic crystals of indigo-blue, or even a precipitate of the same (Hill Hassal, 1853). [The formation of these blue crystals in the putrefying urine of a rabbit, obtained after an injection of carbolic acid into its blood-vessels has been observed by W. Stirling.]—2. Mix in a beaker, equal quantities of urine and hypochlorous acid, and add two drops of a solution of chloride of lime; the mixture at first becomes clear, then blue (Jaffé). Add chloroform, and shake the mixture vigorously for some time; the chloroform dissolves the blue-colouring matter, which is obtained as a deposit, when the chloroform evaporates (Senator, Salkowski).—3. Heat to 70° one part of urine with two parts of nitric acid, and shake up with chloroform; the chloroform dissolves the indigo which is formed, assumes a violet colour and gives an absorption-band between C and D, slightly nearer D (Hoppe-Seyler). Jaffé found in 1500 c.c. of normal human urine,

4.5-19.5 milligrammes of indigo; horse's urine contains 23 times as much. The subcutaneous injection of indol increases the indican in the urine (Jaffé). E. Ludwig obtained indican by heating hæmatin or urobilin with a caustic alkali and zinc dust. It has also been found in the sweat (Bizio).

2. Phenol C_6H_6O (carbolic acid, monohydroxyl benzol, § 252), was discovered by Städeler in human urine (more abundant in horse's urine). It does not occur as carbolic acid, but in combination with a substance from which it is separated by distillation with dilute mineral acids. The "phenol-forming substance" is, according to Baumann, "phenolsulphuric acid" (C_6H_5O, SO_3H), which in urine is united with potash.

If in the employment of carbolic acid it be absorbed, the phenolsulphuric acid becomes greatly increased in amount (Almén, Salkowski), so that sulphuric acid must be united with it; hence, alkaline sulphates are decomposed in the body, so that the latter may be absent from the urine (Baumann). Living muscle or liver when digested in a stream of air for several hours, with blood to which phenol and sodic sulphate are added, yields phenolsulphuric acid; while, under the same circumstances, pyrokatechin forms ethersulphuric acid (Kochs). Phenol is derived from the decomposition of proteids by pancreatic digestion (§ 172, II.), and also from putrefaction (§ 184, 6), the mother-substance being tyrosin. Hence, the formation of phenolsulphuric acid is analogous to the formation of indican.

3. Parakresol (hydroxyltoluol, C_7H_8O) with its isomers ortho- and meta-kresol (the latter in traces), is more abundant in urine (Baumann, Preusse). It also occurs in combination with sulphuric acid.

Test for phenol (and also kresol):—Distil 150 c.c. urine with dilute sulphuric acid. The distillate gives a brown crystalline deposit of tribromophenol with bromine water, as well as a red colour with Millon's reagent.

Hydroxylbenzol (pyrokatechin, hydrochinon), is obtained from urine, when it is heated for a long time with hydrochloric acid.

When carbolic acid is used externally or internally, and it is absorbed, it causes a *deep dark-coloured* urine, due to the oxidation of phenol into *hydrochinon* (orthobioxybenzol = $C_6H_6O_2$), which for the most part appears in the urine as ethersulphuric acid (Baumann and others).

Resorcin which is an isomer of hydrochinon, when administered internally also appears in the urine as ethersulphuric acid.

4. **Pyrokatechin** = $C_6H_6O_2$ (metadihydroxylbenzol), is formed along with hydrochinon from phenol, and is an isomer of the former (Brieger). It behaves like indol and phenol, for when united with sulphuric acid, it forms the pyrokatechin-forming substance. Small quantities sometimes occur in human urine; it is more abundant in the urine of children (Ebstein and Müller); it becomes darker when the urine putrefies.

Perhaps pyrokatechin is formed in the body from decomposed carbohydrates, from which Hoppe-Seyler obtained it by heating them with water under a high pressure, as well as by acting on them with alkalies.

5. **Skatol** (§ 252) which is crystalline, and is formed during putrefaction in the intestine, also appears in the urine as a compound of sulphuric acid. On feeding a dog with skatol, Brieger found much potassic skatol-oxy-sulphate.

Test.—Skatol compounds are recognised by adding dilute nitric acid, which causes a violet colour, or of fuming nitric acid, which precipitates red flakes (Nencki). Its quantity is regulated by the same conditions as indican.

The **aromatic oxyacids**, *hydroparacumaric acid* and *paraoxyphenylacetic acid* (the former a putrefactive product of flesh, the latter obtained by E and H—Salkowski, from putrid albumin), occur in the urine (Baumann, § 252). Shake the urine treated with a mineral acid with ether, evaporate the latter, and dissolve the residue in water. If aromatic oxyacids are present, it gives a red colour with Millon's reagent.

Baumann gives the following series of bodies, which are formed from tyrosin by decomposition and oxidation; most of the substances are formed both during the decomposition of albumin, and also in the intestine, from whence they pass into the urine:—Tyrosin, $C_9H_{11}NO_3 + H_2 = C_9H_{10}O_3$ (hydroparacumaric acid) + NH_3 . $C_9H_{10}O_3 = C_8H_{10}O$ (paraethylphenol, not yet proved) + CO_2 . $C_8H_{10}O + O_3 = C_8H_8O_3$ (paraoxyphenylacetic acid) + H_2O . $C_8H_8O_3 = C_7H_8O$ (parakresol) + CO_2 . $C_7H_8O + O_3 = C_7H_6O_3$ (paraoxybenzoic acid, not yet proved) + H_2O . $C_7H_8O = C_6H_6O$ (phenol) + CO_2 .

Potassium sulphocyanide, derived from the saliva, also occurs in urine. After acidulation with hydrochloric acid, its presence may be detected by the ferric chloride test (§ 146—Gscheidlen and J. Munk). One litre of human urine contains 0.02–0.08 gramme combined with an alkali.

Succinic acid, $C_4H_6O_4$ (Meissner and Shepard), occurs chiefly after a diet of flesh and fat, and almost disappears after a vegetable diet. It is a decomposition product of asparagin, and therefore occurs in considerable amount in the urine after eating asparagus. It is also a product of the alcoholic fermentation (§ 150), and as it passes out of the body unchanged, it occurs in the urine of those who imbibe spirituous liquors. It passes unchanged into the urine (Neubauer).

Lactic acid ($C_3H_6O_3$) is a constant constituent of urine (Lehmann, Brücke). Other observers have found fermentative lactic acid in diabetic urine; sarcolactic acid after poisoning with phosphorus and in trichinosis. **Pepsin** was found constantly in small quantity by Brücke, and v. Jaksch found traces of **acetone** (C_3H_6O) (§ 175), which may be considerably increased when there is great decomposition of the tissues. **Test.**—Acidulate half a litre of urine with hydrochloric acid and distil it. Iodoform is formed on adding caustic soda and a solution of iodine in potassic iodide (Lieben). When acetone is present, orthonitro-benzaldehyd, on adding caustic soda, deposits indigo (Penzoldt).

Bechamp's "**Nephrozymose**" is precipitated from urine by adding to it three times its volume of 90 per cent. alcohol. It is an albuminous body, which at 60°–70°C.

transforms starch into sugar (v. Vintschgau). Grützner found traces of diastatic, peptic, and rennet ferment, especially in urine of high specific gravity.

Traces of sugar (Brücke, Abeles), but only to the amount of 0.0002 per cent. (Bence Jones) occur in normal urine; in the urine of sucklings and pregnant women, *milk-sugar* (Fr. Hofmeister) sometimes occurs. Occasionally traces of volatile fatty acids are met with.

II. The Inorganic Constituents of the Urine.

THE inorganic constituents are either taken into the body as such with the food and pass off unchanged in the urine, or they are formed in the body owing to the sulphur and phosphorus of the food being oxidised and the products uniting with bases to form salts.

The quantity of salts excreted daily in the urine is 9–25 grammes [$\frac{1}{4}$ to $\frac{3}{4}$ oz.].

1. **Sodic chloride**—to the amount of 12 (10–13) grammes [180 grains]—is excreted daily. It is *increased*, after a meal, by muscular exercise, drinking of water, and generally when the quantity of urine is increased, by the free use of large quantities of common salt, but by potash salts also; while it is *diminished* under the opposite conditions.

In disease it is greatly *diminished*; in pneumonia and other inflammations accompanied by effusions, in continued diarrhoea and profuse sweating, constantly in albuminuria and in dropsies. [In cases of pneumonia, sodic chloride may at a certain stage almost disappear from the urine, and it is a good sign when the chlorides begin to reappear.]

In other chronic diseases, the amount of NaCl excreted runs nearly parallel with the amount of urine passed. In conditions of excitement, the amount of sodic chloride is diminished, and potassic chloride increased; in conditions of depression the reverse is the case (Zeulzer).

Test.—Add to the urine nitric acid and then nitrate of silver solution, which gives a white curdy precipitate of chloride of silver. In albuminous urine the albumin must first be removed. *Microscopically* look for the step-like forms of the common salt, and also for the crystals of sodic chloride and urea (§ 256, 4).

2. **Phosphoric acid** occurs in urine, as *acid sodic phosphate* and *acid calcic* and *magnesian phosphates* (Fig. 196, b), to the amount of about 2 grammes daily [30 grains], but it is more abundant after a flesh than after a vegetable diet. The amount increases after a mid-day meal until evening, and falls during the night until next day at noon. It is partly derived from the alkaline and earthy phosphates of the food, and it is partly a decomposition product of lecithin and nuclein. As phosphorus is an important constituent of the nervous system, the

relative increase of phosphoric acid is due to increased metabolism of the nervous substance.

In *fevers*, the increased excretion of potassic phosphate is due to a consumption of blood and muscle (§ 220, 3). It is also *increased* in inflammation of the brain, softening of the bones, diabetes, and oxaluria; and after the administration of lactic acid, morphia, chloral, or chloroform. It is *diminished* during pregnancy, owing to the formation of the fetal bones; also after the use of ether and alcohol, and in inflammation of the kidney.

Test.—*Earthy* phosphates are precipitated by heat. This precipitate is distinguished from albumin, which is also precipitated by heat, by being soluble in nitric acid, which precipitated albumin is not.

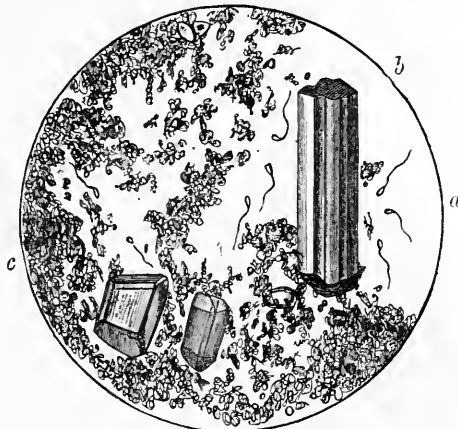

Fig 196.

a, Spermatozoa; *c*, amorphous calcic carbonate; *b*, crystalline magnesian phosphate.

The *amount* of phosphoric acid is estimated by titration with a *standard solution* of uranium acetate; ferrocyanide of potassium being the indicator. The indicator gives a brownish-red colour when there is an excess of free uranium acetate.

In addition to phosphoric acid, phosphorus occurs in an incompletely oxidised form in the urine—*e.g.*, glycerolphosphoric acid (§ 251, 2) (Sotnitzschewsky), which occurs to the amount of 15 milligrammes in a litre of urine, is increased in nervous diseases (Lépine) and after chloroform-narcosis (Zülzer).

3. Sulphuric acid occurs in the urine, the greater part in combination with the *alkalies*, and the remainder united with indol, skatol, and pyrokatechin, in the form of *aromatic ethersulphuric compounds*, (Baumann), the ratio being 1:0.1045 (von den Velden). All conditions which favour the formation of indol, skatol, or pyrokatechin, increase the amount of combined sulphuric acid. The *total daily amount* of sulphuric acid is 2.5–3.5 grammes [37–52 grains]. It is increased by the administration of sulphur (Krause). The sulphuric acid is chiefly derived from the decomposition of proteids, and hence its amount runs parallel with the amount of urea excreted. The amount of alkaline sulphates in the food is, as a rule, very small.

An *increased* excretion of sulphuric acid in fevers indicates an increased metabolism of the tissues of the body. In renal inflammation, it has been observed to be diminished, and in eczema it is greatly increased. Feeding with taurin (which

contains sulphur) in the case of rabbits (but not in carnivora or man) increases the sulphuric acid in the urine (Salkowski). According to Zülzer, a copious secretion of bile lessens the relative amount of sulphuric acid in the urine.

Test.—Barium chloride gives a copious white heavy precipitate of barium sulphate, insoluble in nitric acid.

In addition to sulphuric acid, sulphur ($\frac{1}{2}$) occurs in an incompletely oxidised form in the urine (potassium sulphocyanide, sulphurous acid, cystin, and sulphur-bearing compounds derived from the bile—Kunkel, v. Voit, and others—§ 177, 6). *Hyposulphurous acid*, as an alkaline salt, is an *abnormal* constituent in typhus; and so is sulphuretted hydrogen, which is recognised by the blackening of a piece of paper moistened with lead acetate and ammonia, held over the urine.

4. Excessively minute traces of **silicic acid** and **nitric acid** derived from drinking water have been found in urine. *Organic acids, e.g., citric and tartaric*, when taken internally increase the amount of *carbonates* in the urine. The urine may effervesce on the addition of an acid (Wöhler).

The **sodium** in the urine is chiefly combined with chlorine, but a small part of it is united with phosphoric and uric acids; **potassium** (which is about one-third of the sodium) is chiefly combined with chlorine. In fevers more potash is excreted than soda, and during convalescence, the reverse is the case; **calcium** and **magnesium** exist in *normal acid* urine as chlorides or acid phosphates. If the urine is *neutral*, neutral calcium phosphate and magnesium phosphate are precipitated. If the urine is *alkaline*, calcium carbonate (Fig. 196, c), or tribasic calcium phosphate are deposited as such, while the magnesium is precipitated in the form of ammonio-magnesium phosphate, or triple phosphate. The calcium is derived from the food, and depends upon the amount of lime salts absorbed from the intestine. **Free ammonia** is said to occur (0.72 gramme, or 7 grains daily) in perfectly fresh urine (Neubauer, Brücke), and the amount is greater with an animal than with a vegetable diet (Coranda). The amount of fixed ammonia is increased by the administration of mineral acids (Walter, Schmie-deberg, Gäthgens). **Iron** (1–11 milligrammes per litre) is never absent. There is a trace of **hydric peroxide** (Schonbein), which is detected by its decolorising indigo-solution on the addition of iron sulphate.

Gases.—24.4 c.c. of gas were obtained from one litre of urine—100 volumes of the gases pumped out consisted of 65.40 vol. CO₂, 2.74 O, 31.86 N. After severe muscular action, the amount of CO₂ may be doubled; digestion also increases it.

263. Spontaneous Changes in Urine—Acid and Alkaline Fermentations.

Acid Fermentation.—When perfectly fresh urine is set aside in a cool place, it gradually becomes more acid from day to day. This is called

the "acid fermentation." It seems to be due to the development of a special fungus (Fig. 197, *a*), and the process is accompanied by the deposition of uric acid (*c*), acid sodium urate, in amorphous grains (*b*), and calcium oxalate (*d*). According to Scherer, the fungus and the mucus from the bladder decompose part of the urinary pigment into lactic and acetic acids. The latter sets free uric acid from neutral sodium urate, so that free uric acid and sodium urate must be formed.

Butyric and *formic* acids have been found as abnormal decomposition products of other urinary constituents. When the acid fermentation begins, the urine absorbs oxygen (Pasteur).

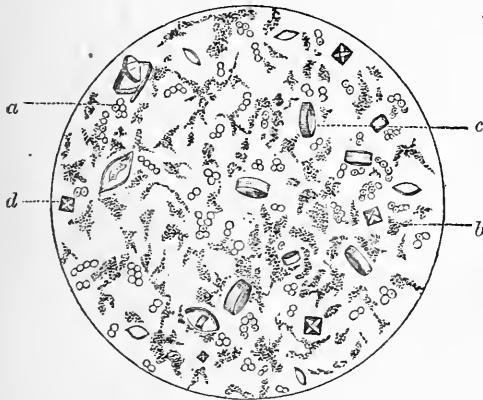

Fig. 197.

Deposit in "acid fermentation" of urine—
a, fungus; *b*, amorphous sodium urate;
c, uric acid; *d*, calcium oxalate.



Fig. 198.

Deposit in *ammoniacal* urine (alkaline fermentation)—*a*, acid ammonium urate;
b, ammonio-magnesium phosphate;
c, putrefactive micro-organisms.

According to Brücke, it is the lactic acid formed from the minute traces of sugar present in urine, which causes the acidity. According to Röhmman, who recognises the acid fermentation as an exceptional phenomenon, the acids are formed from the decomposition of sugar, and from alcohol which may be present accidentally. While the urine is still acid, it becomes turbid and contains nitrous acid, whose source is entirely unknown. According to v. Voit and Hofmann, phosphoric acid and a basic salt are formed from acid sodium phosphate, whereby part of the uric acid is displaced from sodium urate, thus causing the formation of an acid urate.

Alkaline Fermentation.—When urine is exposed for a still longer time, more especially in a warm place, it becomes neutral and ultimately ammoniacal, *i.e.*, it undergoes the alkaline fermentation (Fig. 198).

This condition is accompanied at the beginning by the formation of the *micrococcus ureæ* (Pasteur, Cohn), which is occasionally arranged in chains (Fig. 199) and ultimately in a more radiate manner (Fig. 199, *d*). Under the action of this organism, the urea takes up water, and is decomposed into CO_2 and ammonia—

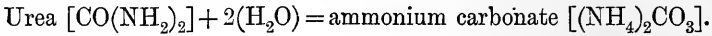

Another, and perhaps, identical coccus decomposes hippuric acid into benzoic acid and glycin (§ 260) (Van Tieghem).

According to Musculus, this decomposition is brought about by the action of an unformed amorphous ferment which he has isolated, and which is perhaps produced by the activity of these organisms.

The presence of ammonia causes the urine to become turbid, and those substances which are insoluble in an alkaline urine are precipitated—*earthy phosphates, acid ammonium urate* (Fig. 198, *a*) in the form of small dark granules covered with spines; and, lastly, the large clear knife-rest or “coffin-lid”

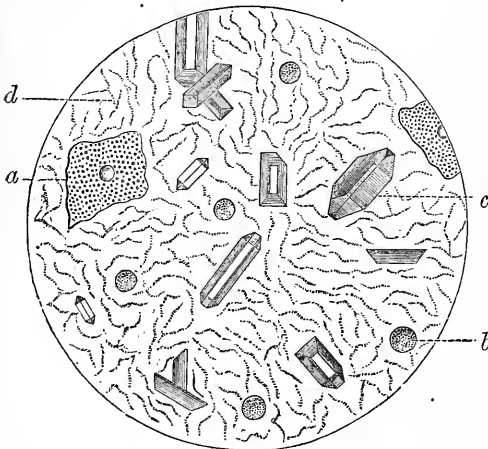

Fig. 199.

Deposit from a case of catarrh of the urinary bladder (ammoniacal fermentation)—*a*, detached epithelium; *b*, pus-corpuscles; *c*, triple phosphate; *d*, micro-organisms.

form of *ammonio-magnesian phosphate*, or triple phosphate (Figs. 200 and 201). [The last substance does not exist *as such* in normal urine, but it is formed when ammonia is set free by the decomposition of urea, the ammonia uniting with the magnesium phosphate. Its presence therefore always indicates ammoniacal fermentation of the urine.] In cases of catarrh or inflammation of the bladder, this decomposition may take place within the bladder, when the urine always contains pus-cells (Fig. 199, *b*) and detached epithelium (*a*). When much pus is present, the urine contains albumin. Ammoniacal urine forms white fumes of ammonium chloride, when a glass rod dipped in hydrochloric acid is brought near it.



Fig. 200.

Ammonio - magnesian phosphate mixed with amorphous granules of calcic phosphate and granular urates.

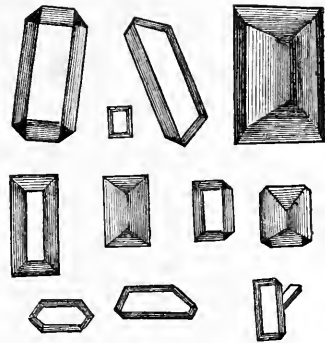

Fig. 201.

The more usual forms of triple phosphate $\times 300$.

[When ammonia is added to normal urine, triple phosphate is precipitated in a *feathery* form.]

264. Albumin in Urine (Albuminuria).

Serum-albumin is the most important *abnormal* constituent in urine which engages the attention of the physician. It is the albumin which occurs in blood (§ 32), and whose characters are described in § 249.

Causes of Albuminuria.—1. Serum-albumin may appear in urine without any apparent anatomical or structural change of the renal tissues. This condition has been called by v. Bamberger "*Hæmatogenous albuminuria*." It occurs but rarely, however, and sometimes in healthy individuals when there is an excess of albumin in the blood-plasma (*e.g.*, after suppression of the secretion of milk), and after too free use of albuminous food. 2. As-a result of *increased blood-pressure* in the renal vessels, *e.g.*, after copious drinking. It may be temporary, or it may be persistent, as in cases of *heart disease*, emphysema, chronic pleural effusions, &c. 3. After section or paralysis of the *vaso-motor nerves* of the kidneys, which causes great congestion of these organs. The albuminuria, which accompanies intense and long-continued abdominal pain, is brought about owing to a reflex paralysis of the renal vessels (Fischel). 4. After violent muscular exercise. [Senator found that forced marches in young recruits were very frequently followed by the appearance of albumin in the urine, which persisted for several days.] *Convulsive* disorders, *e.g.*, epilepsy, the spasms of dyspnoea after strychnin poisoning (Huppert); in shock of the brain, apoplexy, spinal paralysis, and violent emotions; the excessive use of morphia, which perhaps acts on the vaso-motor centres. 5. It may accompany many acute febrile diseases, *e.g.*, the exanthemata (scarlet fever), typhus, pneumonia and pyæmia. In these cases it may be due to the increase of temperature paralysing the vessels, but more probably, the secretory apparatus of the kidney is so changed (*e.g.*, cloudy swelling of the renal epithelium) that the albumin can pass through the renal membranes (Quincke). 6. Certain degenerations and inflammations of the kidneys at several of their stages. 7. Inflammation

or suppuration in the ureter or urinary passages. 8. Certain chemical substances which irritate the renal parenchyma, *e.g.*, cantharides, carbolic acid. 9. The complete withdrawal of common salt from the food. The albumin disappears when the common salt is given again (Wundt, E. Rosenthal).

[Besides being derived from the secreting parenchyma of the kidney, albumin may be derived by admixture with the secretions from any part of the urinary tract, including the vagina and uterus in the female. In some cases the transudation of albumin is favoured by changes in the capillary walls, the albumin being forced through by the intravascular pressure. Sometimes albuminuria occurs during the course of severe typhoid fever, and in acute fevers generally where the temperature is persistently above 40°C. (104°F). The high temperature alters the filtering membrane and permits the filtration of albumin.]

The tests for albumin in urine depend upon the fact that it is precipitated by various reagents:—

(a.) *Nitric Acid*.—By the addition to cold urine of $\frac{1}{3}$ of its volume of nitric acid. In urine which contains a small amount of salts, the turbidity produced by the addition of a small quantity of nitric acid disappears on adding excess of the acid. In such a case a few grains of common salt must be added to the urine (Heynsius.)

[(b.) *Boiling and Nitric Acid*.—Place 10 c.c. of urine in a test tube and boil. If albumin be present in small quantity, a faint haziness, which may be detected in a proper light, will be produced. Add 10 or 12 drops of HNO_3 . If the turbidity disappears it is due to phosphates, while if any remains, it is due to albumin. If albumin be present in large quantity, a copious whitish coagulum is obtained.]

[*Precautions*.—(a.) In all cases, if the urine be turbid, filter it before applying any test. (b.) *How to Boil*.—Boil the upper strata of the liquid, and take care, if any coagulum be formed, that it does not adhere to the side of the tube, else the tube is liable to break. (c.) In performing this test with a neutral solution, note when the precipitate falls, for albumin is precipitated about 70°C., phosphates not till about the boiling point. (d.) *Amount of Acid*.—If too little (2 or 3 drops) HNO_3 be added, or too much (30 or 40 drops) we may fail to detect albumin, although present.]

[(c.) *Heller's Test*.—Place 10 c.c. of the urine in a test-glass, and pour in pure colourless HNO_3 so as to run down the side of the glass, forming a layer beneath the urine. A white zone of coagulated albumin indicates the presence of albumin. In this test it is important to wait a certain time for the development of the reaction. In urines of high specific gravity, a haziness due to acid urates may be formed above, where the two fluids meet, but its upper edge is not circumscribed. The acid decomposes the neutral urates and forms a more insoluble acid salt. This cloud of acid urates is readily dissolved by heat, while the albumin is not; the latter is always a sharply defined zone between the two fluids. In very concentrated urine (rare), nitric acid may gradually

precipitate *crystalline* urea nitrate. In patients taking copaiba, nitric acid, acting on the resin, causes a slight milkiness.]

(d.) *Ferrocyanide Test*.—By the addition of *acetic acid* and *potassium ferrocyanide*. [If albumin be present, a white flocculent precipitate separates in the cold. Dr. Pavy has introduced *pellets*, consisting of a mixture of citric acid and sodic ferrocyanide. All that is required is to add a pellet to the suspected urine. Dr. Oliver uses *papers*, one saturated with citric acid and another with ferrocyanide of potassium. The two papers are added to the clear filtered urine. Other precipitants of albumin, such as small pieces of paper impregnated with potassio-mercuric iodide, are used by Oliver.]

(e.) By *boiling Acid Urine*.—If the urine be alkaline, although albumin may be present, it is not precipitated by heat alone. We require to add acetic acid until a slightly acid reaction is obtained.

In urine which contains a small amount of salts, the incautious addition of acetic acid redissolves the precipitated albumin, so that it is better to add to the urine $\frac{1}{2}$ of its volume of a concentrated solution of common salt.

Boiling may give a precipitate of earthy phosphates in an *alkaline* urine, owing to the CO_2 being driven off. This precipitate might be mistaken for albumin, but on adding acetic or nitric acid, the earthy precipitate is dissolved, while the precipitate of albumin is not dissolved. In testing for albumin, always use *clear* urine. If it is turbid, filter it.

[(f.) *Metaphosphoric acid* is dissolved in water just before it is to be used and added to clear urine (Hindelang). Graham pointed out that metaphosphoric acid precipitated albumin. A 20 per cent. solution of the ordinary glacial phosphoric acid is a good test for albumin, but it also precipitates peptones. It, however, changes into ordinary phosphoric acid by keeping, and then it no longer precipitates albumin.]

[(g.) Acidulate 10 c.c. of urine with acetic acid, and add $\frac{1}{6}$ of its volume of a concentrated solution of sulphate of soda or magnesia. On heating, if albumin be present, a distinct cloudiness is obtained.]

[(h.) In *picric acid*, according to Dr. Johnson, we have a more delicate test for minute traces of albumin than either heat or nitric acid, or than both these tests combined. It is used either in the form of crystals or powder, or as a saturated aqueous solution. Take a four-inch column of urine in a test-tube, hold the tube in a slanting direction, and pour an inch of the picric acid solution on the surface of the urine, where in consequence of its low specific gravity (1,005), it mixes only with the upper layer of the urine. It coagulates any albumin present. The precipitate occurs at once, and is increased by heat, while the urate of soda, which is sometimes precipitated, is soluble on heating.]

[Dr. Roberts regards any test for albumin which requires strong acidulation

with an *organic* acid, citric, acetic, or lactic, as unsatisfactory, since it precipitates mucin. For this reason he rejects the tungstate, mercuric-iodide, and potassic ferrocyanide tests. Dr. Roberts regards the heat test with the addition of a small definite quantity of acetic acid, as the best test for the detection of small quantities of albumin.]

Quantitative Estimation of albumin.—100 c.c. of urine are boiled in a capsule, some acetic acid being ultimately added, whereby the albumin is precipitated in flakes. The precipitate is collected on a weighed, dried (110°), and ash-free filter, and repeatedly washed with hot water, then with alcohol, and completely dried in an air-bath at 110°. Lastly, the dried filter with the albumin is burned in a weighed platinum capsule, and the weight of the ash also deducted from it.

[This method is not available for the busy practitioner on account of the time it takes. Practically, it is sufficient to compare from day to day the proportion that the precipitated albumin bears to the bulk of the urine tested. A graduated tube may be used, so that after the precipitate has subsided, the physician may see whether it occupies one-fourth or one-tenth of the fluid, as the case may be.]

2. **Globulin** occurs sometimes in albuminous urine (Senator, Edlefsen). According to the former, it always accompanies serum-albumin. Its presence is ascertained by adding powdered magnesium sulphate in excess to the urine which precipitates it (§ 32). The more globulin there is in the presence of albumin, the more difficult it is to precipitate it. [Sometimes, when an albuminous urine is dropped into a large cylinder of water, each drop as it sinks is followed by a milky train, and when a sufficient number of drops has been added, the water becomes opalescent, which disappears on adding an acid. The globulin is kept in solution by common salt and other neutral salts, but when these are largely diluted, the globulin is precipitated (Roberts).]

3. **Peptone** (v. Frerichs, 1851) occurs in some specimens of albuminous urine, but also in non-albuminous urine (Gerhardt). Meixner found it constantly in the urine in all cases where suppuration is present, *e.g.*, in exudations, abscesses, resolution of pneumonia, and in articular rheumatism, when the attack is passing off (v. Jaksch). Peptone occurs in pus, and the peptonuria in these cases is a sign of the breaking up of the pus-cells (Hofmeister).

Test.—Separate the albumin by boiling and the addition of acetic acid. Treat the filtrate with three volumes of alcohol; this precipitates the peptone, which, when dissolved in water, gives the characteristic reactions for peptone (p. 332).

4. **Propeptone** occurs much more rarely in osteomalacia (Macynter and Bence Jones)—see p. 331.

5. **Egg-albumin** appears in the urine when much egg-albumin is taken in the food, and also when it is injected into the blood-vessels (§ 192, 4). According to Semmola, the albumin present in the urine in Bright's disease, has undergone a molecular change (similar to egg-albumin), and hence it is excreted.

6. **Mucus** is present in large amount, especially in catarrh of the bladder. It contains numerous mucus-corpuscles, which are scarcely distinguishable from pus-corpuscles. They contain albumin, so that urine containing much mucus is albuminous; mucin is not precipitated by heat, but acetic acid gives a flocculent precipitate in clear urine. [Minute traces of mucin occur normally in urine. If clear normal urine be set aside for a short time, a flocculent haziness like a cloud of cotton wool, is seen floating in the urine. This is mucus entangling a few epithelial cells from the genito-urinary tract.

[**Mucin Reaction.**—According to W. Roberts, the addition of a concentrated solution of citric acid to urine, as in Heller's test (p. 552), where the two fluids meet, causes an opalescent zone gradually to be formed above the layer of acid.]

265. Blood in Urine (Hæmaturia)—Hæmoglobinuria.

I. **Source of the Blood.**—(1) In hæmaturia, the blood may come from any part of the urinary apparatus. 1. In hæmorrhage from the *kidney*, the amount of blood is usually small and well mixed with the urine. The presence of "blood-cylinders," long microscopic blood coagula, casts of the uriniferous tubules are characteristic when they are found in the urine (Fig. 213). The urine usually has a *smoky* appearance.

[The urine slowly dissolves out the colouring matter, the stroma of the corpuscles after a time being deposited as a brownish sediment. The smoky hue occurs only in acid urine; if the urine becomes alkaline, the hue becomes brighter red.]

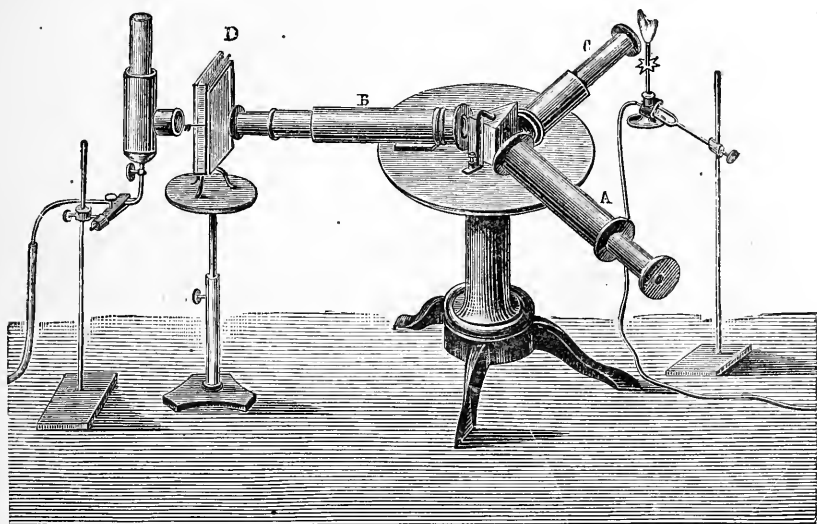

Fig. 202.

Spectroscope for investing the presence of hæmoglobin in urine.

Large coagula are never found in urine mixed with blood derived from the kidney. 2. In hæmorrhage from the *ureter*, we occasionally find worm-like masses of clotted blood, casts of the canal of the ureter. 3. The relatively largest coagula occur in hæmorrhage from the *bladder*. In all cases where blood is present, we must examine microscopically for the blood-corpuscles, and it may be for coagula of fibrin.

II. **Hæmoglobinuria** is quite distinct from hæmaturia. It depends upon the excretion of *hæmoglobin as such* through the kidneys, and it is produced when hæmoglobin occurs free within the blood-vessels, as in cases where the coloured blood-corpuscles have been dissolved inside the blood-vessels (hæmocytolysis). It occurs when foreign blood is transfused, *e.g.*, when lamb's blood is transfused into man. The foreign blood-corpuscles are dissolved in the blood of the recipient, and the hæmoglobin appears in the urine (§102). In addition, microscopic "cylinders," consisting of a globulin-like body tinged yellow with hæmoglobin, may likewise be found in the urine. It also occurs in cases of severe

burns (§10, 3); after decomposition of the blood in pyæmia, scorbutus, purpura, severe typhus, after respiring arseniuretted hydrogen, and after the passage of azobenzol (Baumann and Herter), of naphthol (Kaposi), pyrogallic acid, potassic chlorate, chloral, phosphorus, or carbolic acid into the circulation. These sub-

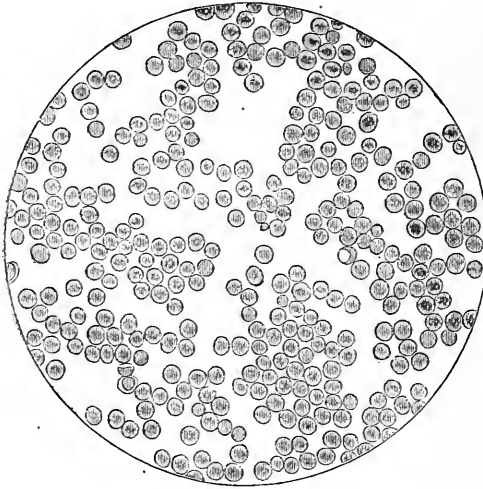

Fig. 203.

Slightly distended red blood-corpuscles in urine $\times 350$.

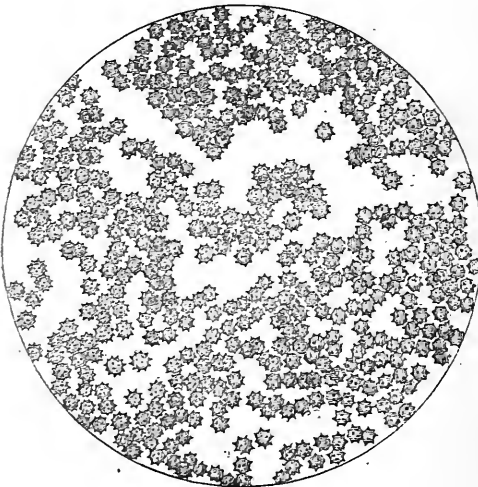

Fig. 204.

Crenated red blood-corpuscles in urine $\times 350$.

stances dissolve the red blood-corpuscles. Sometimes it occurs *periodically* from causes and conditions, as yet but little understood, *e.g.*, the application of cold to the skin.

Tests for Blood in Urine.—1. The colour of bloody urine shows every tint, from a faint red to a dark blackish-brown, according to the amount of blood present. The urine is often turbid.

2. Urine containing blood or blood-pigment contains *albumin*.

3. **Heller's Blood-test.**—Add to urine half its volume of solution of caustic potash, and heat gently. The earthy phosphates are precipitated, and they carry the hæmatin with them, falling as garnet-red flocculi. [This is not a reliable test.]

4. **Hæmin Test.**—The coloured earthy phosphates may be collected on a filter, and from them hæmin may be prepared as directed in § 19.

5. **Almén's Test.**—Add to urine freshly prepared tincture of guaiacum and ozonised ether; a blue colour indicates the presence of blood (§ 37).

6. **Spectroscope,** By the (see § 14). Fig. 202 shows the arrangement of the apparatus. The urine is placed in a glass vessel, D, with parallel sides, 1 centimetre apart (*hæmatinometer*). Light from a lamp, E, passes through the fluid. The lamp, F, illuminates the scale which is seen by the observer through the telescope, A. (a.) *Fresh urine containing blood* gives the spectrum of oxyhæmoglobin (Fig. 11).

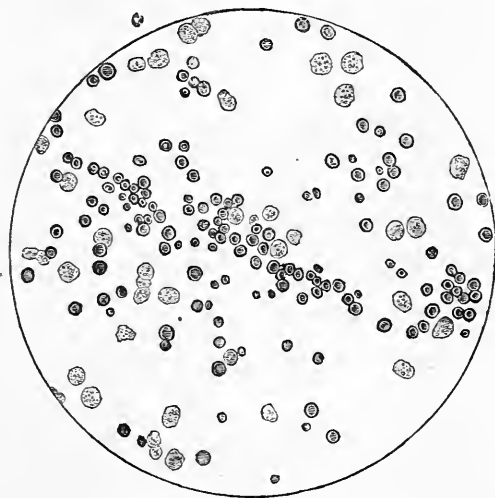

Fig. 205.

Coloured and (a) colourless blood-corpuscles of various forms $\times 350$.

(b.) When bloody urine is exposed for some time, especially in a warm place, it becomes more *acid*, and assumes a dark brownish-black colour. The hæmoglobin becomes changed into *methæmoglobin* (§ 15). It is precipitated by lead acetate, which does not precipitate oxyhæmoglobin; the spectrum of methæmoglobin resembles that of hæmatin in an acid solution (§ 15, Fig. 11). (c.) The *microscopic investigation* must never be omitted. The shape of the corpuscles may vary considerably, as is shown in Figs. 203-205.

Blood-corpuscles may be detected after 2-3 days in acid urine, and they show no disposition to form rouleaux. If the hæmorrhage was pretty large, the corpuscles have either a normal shape or are slightly swollen (Fig. 203). If the urine is concentrated, they are usually crenated (Fig. 204). The corpuscles gradually subside in urine left to stand for a time.

When the blood is slowly and sparingly mixed with the urine, the blood-corpuscles

are of very unequal size, while their colouring matter becomes brown, owing to the formation of methæmoglobin.

Sometimes lymph-corpuscles (Fig. 206) are present in considerable numbers, especially in catarrhal inflammation of the bladder. When quite fresh, they may exhibit *amœboid movement*. In ammoniacal urine, we usually meet with triple

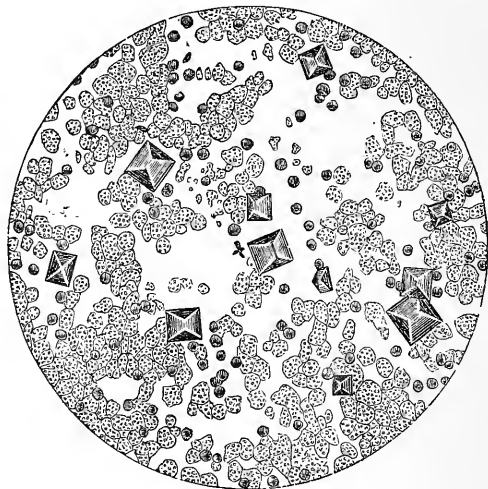

Fig. 206.

Much shrivelled blood-corpuscles in urine (catarrh of the bladder), with numerous lymph-corpuscles, and crystals of triple phosphate $\times 350$.

phosphate crystals (Figs. 200, 201). If the red corpuscles have become faint, they may be made visible by adding a drop of solution of iodine in potassium iodide.

Blood is always present in the urine *during menstruation*.

266. Bile in Urine (Choluria).

The physiological conditions which cause the bile-constituents to appear in the urine are mentioned in part at § 180.

Hæmatogenic, or Anhepatogenic Icterus (Quincke) occurs when bilirubin (§ 20) is formed from extravasated blood by the action of the connective-tissue corpuscles, so that bile pigments, in addition to colouring the tissues, pass into the urine.

I. Bile Pigments.—Their presence is ascertained by *Gmelin-Heintz's test*. *Green* (Biliverdin) is the characteristic hue in the play of colours obtained with this test, which is fully described at p. 357.

Modifications of the Test.—1. If icteric urine be filtered through filtering or blotting paper, a drop of nitric acid containing nitrous acid, when applied to the inner surface of the spread-out filter, gives a yellowish-coloured ring (Rosenbach). 2. In order that the reaction may not take place too rapidly, add a concentrated solution of sodic nitrate, and then slowly pour in sulphuric acid (Fleischl). 3. On shaking 50 c.c. of icteric urine with 10 c.c. chloroform, the bilirubin is dissolved by the latter. On adding bromine water, a beautiful ring of colours is obtained (Maly). If the chloroform extract be treated with ozonised turpentine and dilute

caustic potash, a green colour, due to biliverdin, occurs in the watery fluid (Gerhardt).

In slight degrees of jaundice, urobilin alone may be found (§ 261, 1) (Quincke).

In persistent high fever, the urine contains especially *liliprasin* (Huppert). If it contains *choletelin* alone, add to the urine some hydrochloric acid, and examine it with the spectroscope, which gives a pale absorption-band between *b* and *F* (§ 177, 3, *f*).

Hæmatoidin.—Sometimes crystals of *hæmatoidin* (§ 20, fig. 14) appear in the urine, especially when blood-corpuscles are dissolved within the blood-stream, occasionally in scarlet fever and typhus, and sometimes in cases of periodic hæmoglobinuria. The breaking up of old blood-clots in the urinary passages, as in pyonephrosis (Ebstein), or during the dissolution of necrotic areas (Hofmann and Ultzmann) produces them, and similar crystals occur in analogous cases in the sputum (§ 138). In jaundice due to congestion (§ 180), the identical crystalline substance, bilirubin, is found.

II. Bile acids occur in largest amount in absorption-jaundice, but they are never present to any extent.

The test is described at § 177, 2, the cane-sugar solution consisting of 0.5 gm. to 1 litre of water. If the urine be dilute, it is advisable to concentrate it on a water-bath. Von Pettenkofer's test may be used with the alcoholic extract of the nearly dry residue, but no albumin must be present. Dragendorff found 0.8 gm. in 100 litres of normal urine.

Strassburg's Modification.—Dip filter paper into the urine, to which a little cane-sugar has been added; dry the paper and apply to it a drop of sulphuric acid. A violet-red colour is obtained after a short time.

267. Sugar in Urine (Glycosuria).

Diabetes Mellitus.—The excessively minute trace of *grape-sugar*, which is constantly present in normal urine, sometimes becomes greatly increased and constitutes *diabetes mellitus* or *glycosuria*. The physiological conditions which determine this result are given at § 175. In this condition, the *quantity* of urine is greatly increased—it may reach 10 or more litres. Many pints may be passed daily. The *specific gravity* is also increased (1030–1040). [In a case where a large amount of urine is passed of a *pale* colour and a specific gravity above 1030, always suspect sugar.] A diabetic person gives off relatively more water by the kidneys and less by the skin (and lungs?) than a healthy person. The *colour* is very pale yellow, although the amount of pigment is by no means diminished—it is only diluted. The amount of the nitrogenous urinary excreta is increased. The sugar is increased by a diet of carbohydrates and diminished by an albuminous diet. The uric acid and oxalate of lime are often increased at the commencement of the disease, while yeast cells are constantly present after the urine has been exposed to the air for some time.

Sugar has been found *occasionally* after poisoning with or after the use of morphia, CO, chloral, chloroform, curara; after the injection of ether and amyl nitrite into the blood; and in gout, intermittent fever, cholera, cerebrospinal meningitis, hepatic cirrhosis, and cardiac and pulmonary affections.

Tests.—Any of the tests described at § 149 may be used, but the urine must be free from albumin. The quantitative estimation by fermentation and the titration methods are described in § 149. [The tests for grape-sugar described in § 149 are—1, Trommer's; 2, Fehling's; 3, Moore & Heller's; 4, Büttger's; 5, Mulder & Neubauer's; 6, Fermentation test.]

[7. *Pavy's test* is a modification of Fehling's. In estimating the amount of sugar, Pavy adds a quantity of *ammonia* to the copper solution to prevent the precipitation of the cuprous oxide formed by the reducing action of the grape-sugar. By this method the disappearance of the blue tint in the fluid during titration is rendered more easy. Air must be completely excluded from the ammoniacal cuprous solution during the determination.]

[8. *The Picric Acid and Potash Test*.—Braun showed that grape-sugar, when boiled with picric acid and potash, reduces the yellow picric acid to the deep red picramic acid, the depth of the colour depending on the amount of sugar present. Dr. Johnson uses this test for detecting the presence of sugar in urine, and also for estimating the amount of sugar present—the depth of the red colour obtained in boiling being compared with a standard dilution of ferric acetate. In doing the test, use 1 drachm of urine, $\frac{1}{2}$ a drachm of liquor potassæ, and 10 minims of picric acid solution—make up to 2 drachms with distilled water, and boil the mixture for one minute. This test indicates the presence of 0·6 grain of sugar per fluid ounce of normal urine. Dr. Johnson claims for this test that it possesses all the advantages of the other tests, while it is not affected by uric acid or any other normal ingredient of urine; neither does the presence of albumin interfere with the action of the test as it does with all the forms of copper testing.]

[9. *Indigo-carmin* Test.—A blue solution of this substance, when boiled with diabetic urine containing sodic carbonate, changes from a blue to violet, purple-red, yellow, and finally, straw-yellow colour. After cooling and exposure to the air, the various colours are obtained in the reverse order until the mixture becomes blue again. Dr. Oliver uses this test in the form of papers impregnated with indigo-carmin and sodic carbonate.]

In general the reaction with Fehling's solution is more delicate than with Trommer's test (Worm Müller and Hagen). In doing Trommer's test, Worm Müller recommends that the mixture of the urine and cupric sulphate solution be boiled by itself, and the caustic potash by itself for 20 seconds, when the two fluids are mixed and set aside for some time.

The **quantitative estimation** by (a) *fermentation* is described at § 150.

(b) *Titration with Fehling's solution or Volumetric analysis.*

[*Preparation of Fehling's Solution*.—34·64 grammes of pure crystalline cupric sulphate are powdered and dissolved in 200 c.c. of distilled water; in another vessel dissolve 173 grammes of Rochelle Salts in 480 c.c. of pure caustic soda, specific gravity 1·14. Mix the two solutions and dilute the deep coloured fluid which results to 1 litre. *N.B.*—Fehling's solution ought not to be kept too long; it is apt to decompose, and should therefore be preserved from the light, or protected with opaque paper pasted on the bottle. Some other substances in urine, *e.g.*, urates and uric acid, reduce cupric oxide.]

[**Volumetric Analysis**.—10 c.c. of Fehling's solution = 0·05 gramme of sugar.

1. Ascertain the quantity of urine passed in 24 hours. 2. Filter the urine and remove any albumin present by boiling and filtration. 3. Dilute 10 c.c. of Fehling's solution with about 20 times its volume of distilled water, and place it in a white porcelain capsule on a wire gauze support under a burette. (It is diluted because any change of colour is more easily observed.) 4. Take 5 c.c. of the urine, add 95 c.c. of distilled water, and place the diluted urine in a burette. 5. Gradually boil the diluted Fehling's solution, and whilst it is boiling, gradually add the diluted urine from the burette, until all the cuprous oxide is precipitated as a reddish powder, and the supernatant fluid has a straw-yellow colour, not a trace of blue remaining. Read off the number of c.c. of *dilute* urine employed. Say 36 c.c. were used—that, of course, represents 1·8 c.c. of the original urine.

Suppose the patient passes 8,550 c.c., as 1·8 c.c. of urine reduced all the cupric oxide in the 10 c.c. of Fehling's solution, it must contain 0·05 gramme sugar, hence,

1.8 : 8550 :: .05 : $\frac{8550 \times .05}{1.8} = 237.5$ grammes of sugar passed in 24 hours.]

Circumpolarisation.—The saccharimeter of Soliel-Ventzke may be used to determine the amount of sugar present. It may also be used for the quantitative

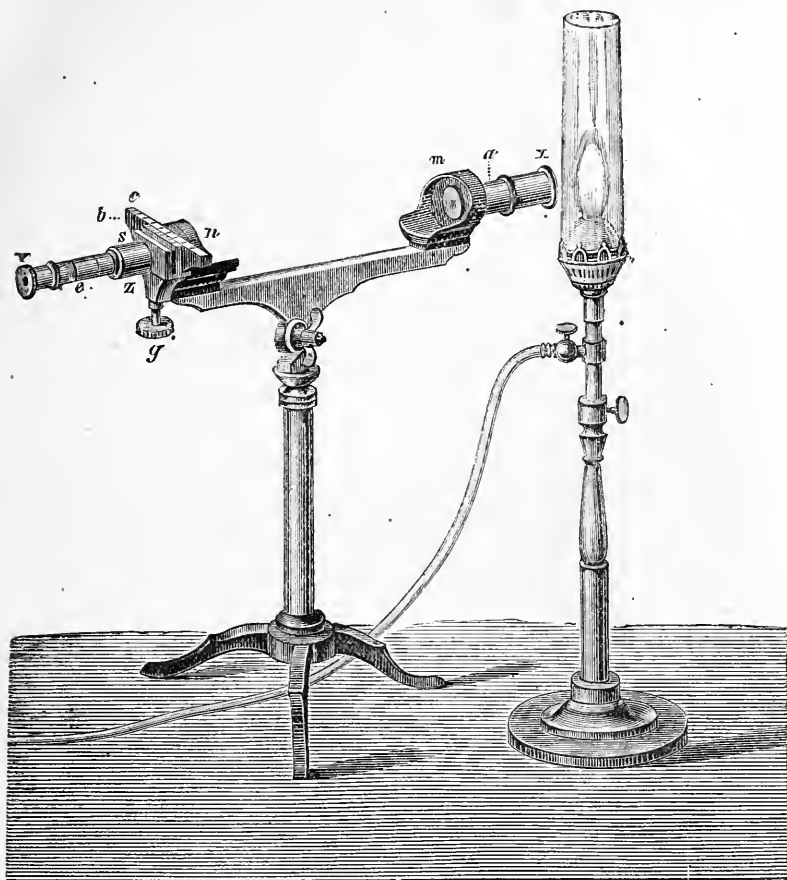

Fig. 207.

Soliel-Ventzke's Polarisation Apparatus.

estimation of albumin. Sugar rotates the ray of polarised light to the right and albumin to the left. The amount of rotation, or "specific rotatory power," is directly proportional to the amount of the rotating substance present in the solution, so that the amount of rotation of the ray indicates the amount of the substance present.

In Fig. 207 the light from the lamp falls upon a crystal of calc-spar. Two Nicol's prisms are placed at *v* and *s*, *v* is movable round the axis of vision, while *s* is fixed. In *m* Soleil's double plate of quartz is placed; so that one-half of it rotates the ray of polarised light as much to the right as the other rotates it to the left. In *n* the field of vision is covered by a plate of *left-rotatory* quartz. At *b c* is the *compensator*, composed of two right-rotatory prisms of quartz, which can be dis-

placed laterally by the milled head, *g*, so that the polarised light passing through the apparatus can be made to pass through a thicker or thinner layer of quartz. When these right-rotatory prisms are placed in a certain position, the rotation of left-rotatory quartz at *n* is exactly neutralised. In this position the scale on the compensator has its nonius exactly at *o*, and both halves of the double plate at *m* appear to have the same colour to the observer, who from *v* looks through the telescope placed at *e*. Rotate the Nicol's prism at *v* until a bright rose-coloured field is obtained. In this position the telescope must be so adjusted that the vertical line bounding the two halves shall be distinctly visible. The apparatus is now ready for use.

Fill a tube, 1 decimetre in length, with urine containing sugar or albumin, the urine being perfectly clear. The tube is placed between *m* and *n*. By rotating the Nicol's prisms, *v*, the rose-colour is again obtained. The compensator at *g* is then rotated until both halves of the field of vision have exactly the same colour. When this is obtained, read off on the scale the number of degrees the nonius is displaced to the right (sugar) or to the left (albumin) from zero. The number of degrees indicates directly the number of grammes of the rotating substance present in 100 c.c. of the fluid. If the fluid is very dark-coloured, it must be decolorised by filtering it through animal charcoal (Seegen) [or the colouring matter may be precipitated by the addition of lead acetate.] If the sugary urine contains albumin, the latter must be removed by boiling and filtration. A turbidity not removed by filtration may be got rid of by adding a drop of acetic acid or several drops of sodic carbonate or milk of lime, and afterwards filtering.

Milk-sugar is sometimes found in the urine of women who are nursing; when the secretion of milk is arrested, absorption taking place from the breasts (Kirsten, Spiegelberg). *Laevulose* (p. 511) is sometimes found in diabetic urine.

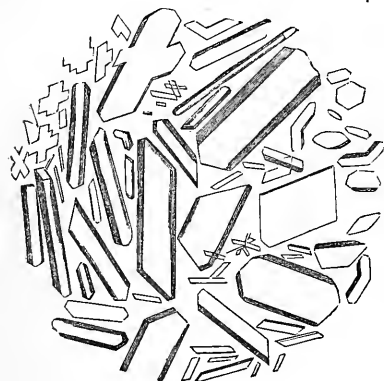

Fig. 208.

Inosit crystallised partly from alcohol and partly from water (after Funke).

dark-red colour, which disappears on cooling, is obtained (Gallois, Külz).

Diabetic urine sometimes contains **acetone** (§ 262). **Dextrin** has also been found in diabetic urine. **Inosit** or muscle-sugar (p. 513) is sometimes found in diabetes, in polyuria (Mosler) and albuminuria. It is found in traces, even in normal urine. Occasionally, after the piqure in animals (§ 175) inosit, instead of grape-sugar, appears in the urine (Fig. 208). In testing for inosit, remove the grape-sugar by fermentation, and the albumin by heat, after the addition of a few drops of acetic acid and sodic sulphate. Some of the filtrate is evaporated nearly to dryness on a capsule. To the residue add two drops of mercuric nitrate (Liebig's titration-fluid for urea), which gives a yellow precipitate. When this coloured residue is spread out and carefully heated a

268. Cystin = $C_3H_7NSO_2$.

This left-rotatory body occurs very seldom in large amount in urine, although it seems to be a constituent of normal urine. It may be in solution or in the form

of hexagonal crystals (Fig. 209, *A*). It is insoluble in water, alcohol, and ether, but easily soluble in ammonia, from which solution it may be crystallised.

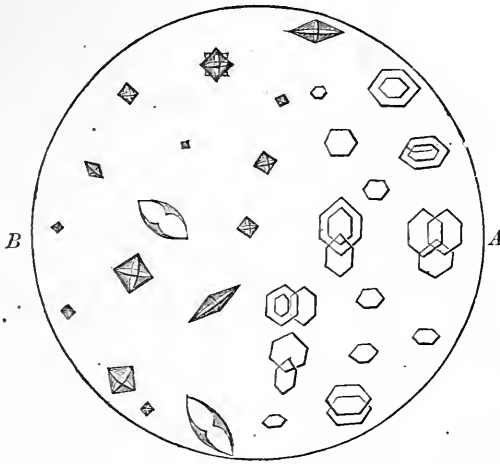

c
Fig. 209.

A, Crystals of cystin; *B*, oxalate of lime; *c*, hour-glass forms of *B*.

269. Leucin = $C_6H_{13}NO_2$. Tyrosin = $C_9H_{11}NO_3$.

Both bodies occur in the urine in acute yellow atrophy of the liver, and in poisoning by phosphorus. (Their formation during pancreatic digestion has been

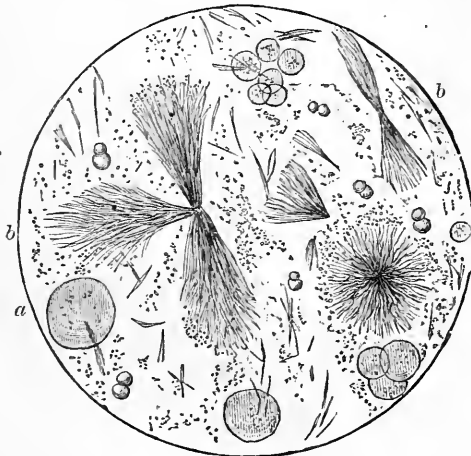

Fig. 210.

a a, Leucin balls; *b b*, tyrosin sheaves; *c*, double balls of ammonium urate.

referred to in § 170, II). As the urea excreted is usually diminished at the same time, it is assumed that, in these diseases, the further oxidation of the derivatives

of the proteids is interfered with. **Leucin**, which is either precipitated spontaneously or obtained after evaporating an alcoholic extract of the concentrated urine, occurs in the form of *yellowish-brown balls* (Fig. 210, *aa*), often with concentric markings, or with fine spines on their surface. When heated, it sublimes without fusing.

Tyrosin forms silky colourless sheaves of needles (Fig. 210, *bb*). When boiled with mercuric nitrate and nitric acid it gives a red colour, and afterwards a brownish-red precipitate. When slightly heated with a few drops of concentrated sulphuric acid, it dissolves with a temporary deep-red colour. On diluting with water, adding barium carbonate until it is neutralised, boiling, filtering, and adding dilute ferric chloride, a violet colour is obtained (Piria, Städeler).

270. Deposits in Urine.

Deposits may occur in normal as well as in pathological urine, and they are either "*organised*" or "*unorganised*."

I. Organised Deposits.

A. Blood: red and white blood-corpuscles and sometimes fibrin (Figs. 203-206).

B. Pus, in greater or less amount, in catarrh or inflammation of the urinary passages. Pus cells exactly resemble colourless blood-corpuscles (Fig. 6).

Donné's Test.—Pour off the supernatant fluid and add a piece of caustic potash to the deposit; if it be pus it becomes gelatinous, ropy, and more viscid (alkali-albuminate). **Mucus,** when so acted on, becomes more fluid and mixed with flocculi.

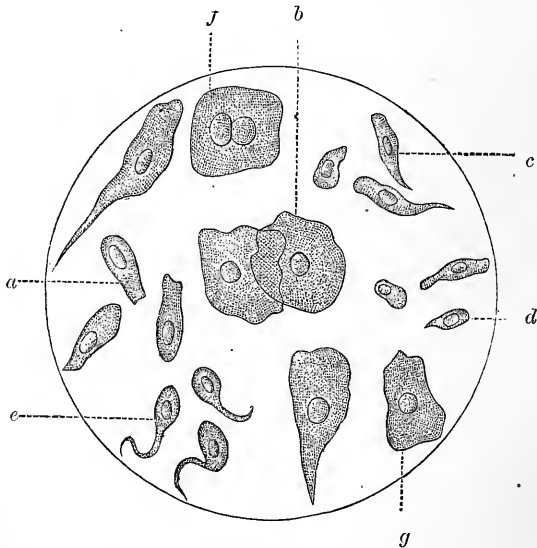

Fig. 211.

a, Epithelium from the human urethra; *b*, vagina; *c*, prostate; *d*, Cowper's glands; *e*, Littre's glands; *f*, female urethra; *g*, bladder.

C. Epithelium of various forms occurs, but it is not always possible to say from whence it is derived (Fig. 211).

D. Spermatozoa may be present (Fig. 196, *a*).

E. Lower organisms occur in the urinary passages very seldom, but they may be present, *e.g.*, in the bladder, when germs are introduced from without by means of a dirty catheter. [Before introducing a catheter into the bladder we ought always to make sure that the instrument is perfectly aseptic.] Micrococci

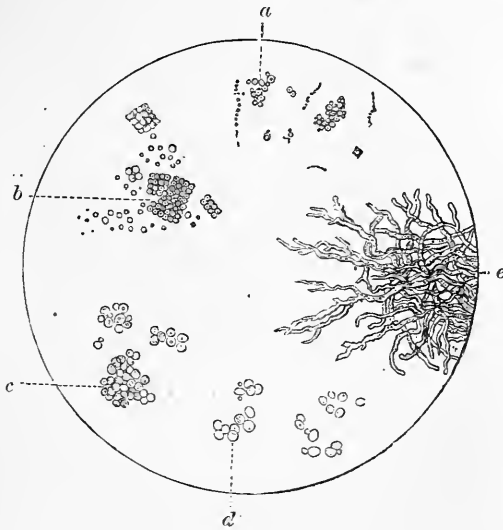

Fig. 212.

a, Micrococci in short chains and groups; *b*, sarcinae; *c*, fungi from acid fermentation; *d*, yeast-cells from diabetic urine; *e*, mycelium of a fungus.

are found in the urine in certain diseases, *e.g.*, diphtheria. The following forms can be distinguished:—

1. **Schizomycetes** (§ 184). Normal human urine contains neither schizomycetes nor their spores. In pathological conditions, however, fungi may pass from the blood into the urinary tubules and thus reach the urine (Leube).

During the alkaline fermentation of urine, micrococci (*Micrococcus ureæ*), rod-shaped bacteria or bacilli (Figs. 198, 199) may occur. *Sarcinae* belong to the above group (§ 186).

2. **Saccharomycetes** (fermentation fungi): (*a*) The fungus of the acid urine fermentation (*S. urine*) consists of small bladder-like cells arranged either in chains or in groups (Figs. 199, *d*; 212, *c*). (*b*) Yeast (*S. fermentum*) occurs in diabetic urine, as oval cells with a dotted eccentrically placed nucleus (Fig. 212, *d*).

3. **Phycomycetes** (moulds) occur in putrid urine (Fig. 212, *e*). They are without clinical significance.

F. Tube Casts.—The occurrence of tube casts, *i.e.*, casts of the uriniferous tubules (Henle, 1837) is of great importance in connection with the diagnosis of renal diseases. If these structures are relatively thick and straight, they probably come from the collecting tubules, but if they are smaller and twisted, they probably come from the convoluted tubules. There are various forms of tube casts:—1. **Epithelial** casts, consisting of the actual cells of the uriniferous tubules. They indicate that there is no very great change going on, but only that, as in catarrhal inflammation of any mucous membrane, the epithelium is in process of desquamation. 2. **Hyaline** casts (Fig. 214) are quite clear and homogeneous, usually long

and small; sometimes they are "finely granular," from the presence of fat or other particles. They are best seen after the addition of a solution of iodine. They are

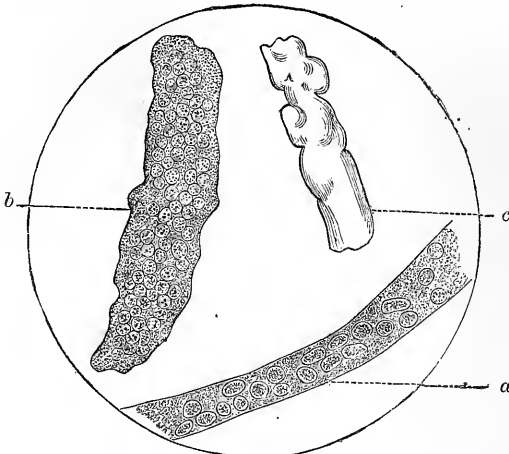

Fig. 213.

c, Blood cast; b, granular cast; a, amyloid or waxy cast.

probably formed from albumin, which passes into the uriniferous tubules. They are dissolved in alkaline urine, while acid urine favours their formation. They usually occur in the late stages of renal disease, after the tubular epithelium has

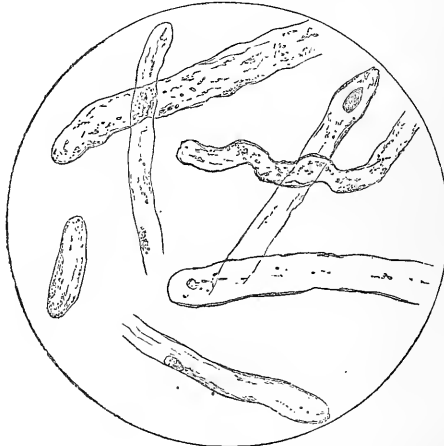

Fig. 214.

Hyaline Casts.

been shed. 3. *Coarsely granular* casts (Fig. 213, b), brownish-yellow, opaque, and granular, usually broader than 2. There are various forms. Not unfrequently there are *fatty* granules and, it may be, epithelial cells in them. 4. *Amyloid* casts occur in amyloid degeneration of the kidneys (Fig. 213, a). They are refractive and completely homogeneous (Fig. 213, a), and give a blue colour (amyloid reaction) with sulphuric acid and iodine. 5. *Blood* casts occur in capillary

hæmorrhage of the kidney, and consist of coagulated blood entangling blood-corpuscles (Fig. 213, c). When tube casts are present, the urine is always *albuminous*.

II. Unorganised Deposits.

Some of these are *crystalline* and others are *amorphous*, and they have been referred to in treating of the urinary constituents.

271. General Scheme for detecting Urinary Deposits.

I. In **acid urine** there may occur—

1. An *amorphous granular* deposit :

- (a.) Which is dissolved by heat and reappears in the cold; the deposit is often reddish in colour = **urates** (Fig. 197).
- (b.) Which is not dissolved by heat, but is dissolved by acetic acid, but without effervescence = probably **tribasic calcium phosphate**.
- (c.) Small bright refractive granules, soluble in ether = **fat** or **oil granules** (§ 41, *Lipæmia*). Fat occurs in the urine, especially when the round worm, *filaria sanguinis hominis*, is present in the blood; sometimes, along with sugar, in phthisis, poisoning with phosphorus, yellow fever, pyæmia, after long-continued suppuration, and lastly, after the injection of fat or milk into the blood (§ 102). It occurs also in fatty degeneration of the urinary apparatus, admixture with pus from old abscesses and after severe injuries to bones. In these cases attention ought to be directed to the presence of cholesterolin and lecithin. Very rarely is the fat present in such amount in the urine as to form a cream on the surface (*chyluria*).

2. A **crystalline** deposit may be—

- (a.) **Uric acid** (Figs. 190, 191, 197, and 215).
- (b.) **Calcium oxalate** (Figs. 197, 209, and 216)—octahedra insoluble in acetic acid.
- (c.) **Cystin** (Figs. 209 and 217).
- (d.) **Leucin and tyrosin** — very rare (Fig. 210).



Fig. 215.

The usual forms of uric acid sediment, with blood-corpuscles intermixed (after Funke).

II. In **alkaline urine** there may occur—

1. A *completely amorphous granular* deposit, soluble in acids without effervescence = **tribasic calcium phosphate**.
2. *Sediment crystalline, or with a characteristic form.*
 - (a.) **Triple phosphate** (Figs. 198, 199, 200, 201, and 206)—soluble at once in acids.

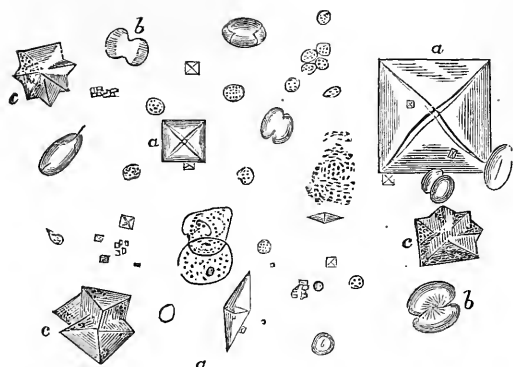

Fig. 216.

Oxalate of lime—*a*, octahedra; *b*, dumb bell; *c*, compound octahedra; circular and oval crystals (after Beale).

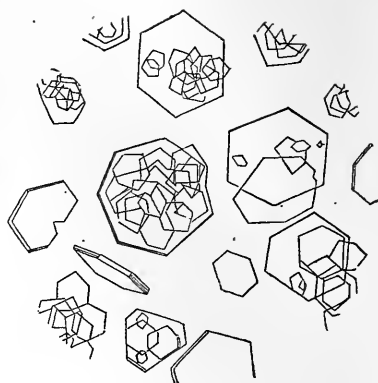

Fig. 217.

Cystin precipitated by acetic acid from its ammoniacal solution (after Thudichum).

- (*b*.) **Acid ammonium urate**—dark-yellowish small balls often beset with spines, also amorphous (Figs. 198 and 210).
- (*c*.) **Calcium carbonate**—small whitish balls or biscuit-shaped bodies. Acids dissolve them with effervescence (Fig. 196).
- (*d*.) **Leucin and tyrosin** (Fig. 210)—very rare.
- (*e*.) **Neutral calcic phosphate** and long plates of tribasic magnesian phosphate (Fig. 196).

Organised deposits may occur both in alkaline and in acid urine; pus cells are more abundant in alkaline urine, and so are the lower vegetable organisms.

272. Urinary Calculi.

Urinary concretions may occur in granules the size of sand, or in masses as large as the fist. According to their size they are spoken of as sand, gravel, stone, or calculi. They occur in the pelvis of the kidney, ureters, bladder, and sinus prostaticus.

We may classify them as follows (Utzmann):—

1. Calculi, whose nucleus consists of the *sedimentary forms that occur in acid urine* (primary formation of calculi). They are all formed in the kidney, and pass into the bladder, where they enlarge according to the growth of the crystals in the urine.

2. Calculi, which are either *sedimentary forms from alkaline urine*, or whose nucleus consists of a *foreign body* (secondary formation of calculi). They are formed in the bladder.

The *primary* formation of calculi begins with free uric acid in the form of sheaves (Fig. 190, *c*) which form a nucleus, with concentric layers of oxalate of lime. The *secondary* formation occurs in *neutral* urine by the deposition of calcic carbonate and crystalline calcic phosphate; in *alkaline* urine, by the deposition of acid ammonium urate, triple phosphate, and amorphous calcic phosphate.

Chemical Investigation.—Scrape the calculus, burn the scrapings on platinum foil to ascertain if they are burned or not.

I. *Combustible* concretions can consist only of organic substances.

(*a*.) Apply the murexide test (§ 259, 2), and if it succeeds *uric acid* is present.

Uric acid calculi are very common, often of considerable size, smooth, fairly hard, and yellow to reddish-brown in colour.

(b.) If another portion, on being boiled with caustic potash, gives the odour of ammonia (or when the vapour makes damp turmeric paper brown, or if a glass rod dipped in HCl and held over it gives white fumes of ammonium chloride), the concretion contains *ammonium urate*. If *b* gives no result, pure uric acid is present. Calculi of ammonium urate are rare, usually small, of an earthy consistence—*i. e.*, soft, and pale-yellow or whitish in colour.

(c.) If the *xanthin* reaction succeeds (§ 260), this substance is present (rare). *Indigo* has been found in one occasion in a calculus (Ord).

(d.) If after solution in ammonia, hexagonal plates (Fig. 209, A, Fig. 217) are found, *cystin* is present.

(e.) Concretions of *coagulated blood*, or *fibrin*, without any crystals, are rare. When burned they give the odour of singed hair. They are insoluble in water, alcohol, and ether; but are soluble in caustic potash, and are precipitated therefrom by acids.

(f.) *Urostealith* is applied to a caoutchouc-like soft elastic substance, and is very rare. When dry it is brittle and hard, brown or black. When warm it softens, and if more heat be applied it melts. It is soluble in ether, and the residue after evaporation becomes violet on being heated. It is soluble in warm caustic potash, with the formation of a soap.

II. If the concretions are only *partly combustible*, thus leaving a residue, they contain organic and inorganic constituents.

(a.) Powder a part of the stone, boil it in water, and filter while hot. The urates are dissolved. To test if the uric acid is united with soda, potash, lime, or magnesia, the filtrate is evaporated and burned. The ash is investigated with the spectroscope (§ 14), when the characteristic bands of sodium or potash are observed. Magnesian urate and calcic urate are changed into carbonate by burning. To separate them dissolve the ash in dilute hydrochloric acid, and filter. The filtrate is neutralised with ammonia, and again redissolved by a few drops of acetic acid. The addition of ammonium oxalate precipitates *calcic oxalate*. Filter, and add to the filtrate sodic phosphate and ammonia, when the magnesia is precipitated as *ammonio-magnesian phosphate*.

(b.) *Calcic oxalate* (especially in children, either as small smooth pale stones, or in dark, warty, hard "mulberry calculi") is not affected by acetic acid, is dissolved by mineral acids without effervescence, and again precipitated by ammonia. Heated on platinum foil it chars and blackens, then it becomes white, owing to the formation of calcic carbonate, which effervesces on the addition of an acid.

(c.) *Calcic carbonate* (chiefly in whitish-gray, earthy, chalk-like calculi, somewhat rare) dissolves with effervescence in hydrochloric acid. When burned it first becomes black, owing to admixture with mucus, and then white.

(d.) *Ammonio-magnesian phosphate* and *basic calcic phosphate* usually occur together in soft, white, earthy stones, which occasionally are very large. These stones show that the urine has been ammoniacal for a very long time. The first substance when heated gives the odour of ammonia, which is more distinct when heated with caustic potash; is soluble in acetic acid without effervescence, and is again precipitated in a crystalline form from this solution on the addition of ammonia. When heated it fuses into a white enamel-like mass; [hence, it is called "fusible calculus"].

Basic calcic phosphate does not effervesce with acids. The solution in hydrochloric acid is precipitated by ammonia. When ammonium oxalate is added to the acetic acid solution, it yields calcic oxalate.

(e.) *Neutral calcic phosphate* is rare in calculi, while it is frequent in the form of gravel. Physically and chemically, these concretions resemble the earthy phosphates, only they do not contain magnesia.

273. The Secretion of Urine.

[The functions of the kidney are—

1. To excrete waste products, chiefly nitrogenous bodies and salts ;
2. To excrete water ;
3. And perhaps also to reabsorb water from the uriniferous tubules, after it has washed out the waste products from the renal epithelium.

The chief parts of the organs concerned in 1, are the epithelial cells of the convoluted tubules ; the glomeruli permit water and some solids to pass through them, while the constrictions of the tubules may prevent the too rapid outflow of water, and thus enable part of it to be reabsorbed (Brunton).]

Theories.—The two chief older theories regarding the secretion of urine are the following:—1. According to **Bowman's** view (1842), through the glomeruli are filtered only the *water* and some of the highly diffusible and soluble salts present in the blood, while the specific urinary constituents are secreted by the activity of the epithelium of the urinary tubules, and are extracted or removed from the epithelium by the water flowing along the tubules. 2. **C. Ludwig** (1844) assumes that *very dilute urine* is secreted or filtered through the glomerulus. As it passes along the urinary tubules it becomes more concentrated, owing to endosmosis. It gives back some of its water to the blood and lymph of the kidney, thus becoming more concentrated, and assuming its normal character.

The secretion of urine in the kidneys does not depend upon definite physical forces *only*. A great number of facts force us to conclude that the vital activity of certain secretory cells plays a foremost part in the process of secretion (R. Heidenhain).

The secretion of urine embraces—(1) The **water**, and (2) the **urinary constituents** therein dissolved ; both together form the urinary secretion. The **amount of urine** depends chiefly upon the amount of water which is secreted by, or rather filtered through, the glomerulus ; the *amount of solids* dissolved in the urine determines its *concentration*.

A. The **amount of urine**, which is secreted chiefly within the Malpighian capsules, *depends primarily upon the blood-pressure in the area of the renal artery*, and follows, therefore, the laws of **filtration** (§ 191, II.) (Ludwig and Goll). [In this respect the secretion of urine differs markedly from that of saliva, gastric juice, or bile. We may state it more accurately thus, that the amount of urine depends very closely upon the difference of pressure between the blood in the glomeruli and

the pressure within the renal tubules. If the ureter be ligatured, the secretion of urine is ultimately arrested, even although the blood-pressure be high. The secretion may also be arrested by ligature of the renal vein; and in some cases of cardiac or pulmonary disease, the venous congestion thereby produced may bring about the same result.]

The amount of urine secreted does not depend upon the hydrostatic pressure alone, but it seems that the epithelial cells covering the glomerulus also participate in the process of secretion. Besides the water, a certain amount of the salts present in the urine is excreted through the glomeruli. The *serum-albumin of the blood, however, is prevented from passing through.* With regard to the secretory activity of these cells, the quantity of water must also depend upon the amount and rate at which the material to be secreted is carried to the glomeruli by the blood-stream, and also upon the amount of the urinary constituents and water present in the blood (R. Heidenhain).

Only when the vitality of the secretory cells is intact is there *independent activity* of these secretory cells (Heidenhain). When the renal artery is closed temporarily, their activity is paralysed, so that the kidneys cease to secrete, and even after the compression is removed and the circulation re-established, secretion does not take place for some time (Overbeck).

That the secretion depends *in part upon the blood-pressure* is proved by the following considerations:—

1. *Increase of the total contents of the vascular system, so as to increase the blood-pressure,* increases the amount of water which filters through the glomeruli. The injection of water into the blood-vessels or drinking copious draughts of water acts partly in this way. If the blood-pressure rises above a certain height, albumin may pass into the urine. The *active participation* of the cells of the glomeruli is rendered probable by the fact that, after very copious drinking, the blood-pressure is not always raised (Pawlow); further, after *profuse transfusion*, the quantity of urine is not increased. Conversely, the excretion of water, owing to profuse sweating or diarrhoea, copious hæmorrhage; or prolonged thirst, diminishes the secretion of urine.

2. *Diminution of the capacity of the vascular system,* provided the pressure within the renal area be thereby increased, acts in a similar manner. This may be produced by contraction of the cutaneous vessels, owing to the action of cold, stimulation of the vaso-motor centre, or large vaso-motor nerves, ligature, or compression of large arteries (§ 85, e), or enveloping the extremities in tight bandages. All these conditions cause an increase in the amount of urine, and of course the opposite conditions bring about a diminution of urine, e.g., the action of heat on the skin causing redness and dilatation of the

cutaneous vessels, weakening of the vaso-motor centre, or paralysis of a large number of vaso-motor nerves.

3. *Increased action of the heart*, whereby the tension and rapidity of the blood in the arteries are increased (§ 85, c), augments the amount of urine; conversely, feeble action of the heart (paralysis of motor cardiac nerves, disease of the cardiac musculature, certain valvular lesions), diminishes the amount. Artificial stimulation of the vagi in animals, so as to slow the action of the heart, and thus diminish the mean blood-pressure from 130 to 100 mm. Hg., causes a diminution in the amount of urine to the extent of one-fifth (Göfl, Cl. Bernard); when the pressure in the aorta falls to 40 mm. the secretion of urine ceases. [If the medulla oblongata be divided (dog) there is an immediate fall of the *general* blood-pressure, and although, as a general rule, the secretion of urine is arrested when the pressure falls to 40–50 mm. Hg., yet secretion has been observed to take place with a lower pressure than this.]

4. The amount of urine secreted *rises or falls according to the degree of fulness of the renal artery* (Ludwig, Max Herrmann); even when this artery is moderately constricted in animals, there is a decided diminution in the amount of urine.

It is most important in connection with certain renal diseases to note that, ligature of the renal artery, even when it is obliterated for only two hours, causes necrosis of the epithelium of the uriniferous tubules. Lime afterwards becomes deposited in such epithelium in rabbits. When the arterial anæmia is kept up for a long time, the whole renal tissue dies (Litten). After long-continued ligation of the renal artery, the epithelium of the glomeruli becomes greatly changed (Ribbert).

5. Most *diuretics* act in one or other of the above-mentioned ways.

[Some diuretics act by increasing the *general* blood-pressure (digitalis and the action of cold on the skin), others may increase the blood-pressure *locally* within the kidney, and this they may do in several ways. The nitrites are said to paralyse the muscular fibres in the vasa afferentia, and thus raise the blood-pressure within the glomeruli. But some also act on the *secretory epithelium*, such as urea and caffeine. Brunton recommends the combination of diuretics in appropriate cases, and the diuretics must be chosen according to the end in view—as we wish to remove excess of fluids from the tissues and serous cavities, or as we wish to remove injurious waste products, or merely to dilute the urine.]

[6. The amount of urine also depends upon the *composition of the blood*. Drinking a large quantity of water, whereby the blood becomes more watery, increases the amount of urine, but this is true only within certain limits. It is not merely the increase of volume of the blood acting mechanically which causes this increase, as we know that large quantities of fluid may be transfused without the general blood-pressure being materially raised thereby.]

[Heidenhain argues that it is not so much the *pressure* of the blood in the glomeruli as its *velocity* which determines the process of the secretion of water in the kidney. He contends that, while increase of the pressure in the renal artery causes an increased flow of urine, ligation of the renal vein, whereby the pressure in the glomeruli is also increased, arrests the secretion altogether. In both cases the pressure is increased within the glomeruli, and the two cases differ essentially in the *velocity* of the blood-current through the glomeruli.]

Pressure in the Vas Afferens.—The pressure in each *vas afferens* must be relatively great, because (1) the double set of capillaries in the kidney offers considerable resistance, and because (2) the lumen of the vas efferens is narrower than that of the vas afferens. Hence, owing to the high blood-pressure in the capillaries of the renal glomeruli, filtration must take place from the blood into the Malpighian capsules. When the vasa afferentia are dilated, *e.g.*, through the action of the nervous system on their smooth muscular fibres, the filtration-pressure is increased, while, when they are contracted, the secretion is lessened. When the pressure becomes so diminished as to retard greatly the blood-stream in the renal vein, the secretion of urine begins to be arrested. *Occlusion of the renal vein completely suppresses the secretion* (H. Meyer, v. Frerichs). Ludwig concluded from this observation that the filtration or excretion of fluid could not take place through the renal capillaries *proper*, as owing to occlusion of the renal vein the blood-pressure in these capillaries must rise, which ought to lead to increased filtration. Such an experiment points to the conclusion that the *filtration must take place through the capillaries of the glomeruli*. The venous stasis distends the vas efferens which springs from the centre of the glomerulus, and compresses the capillary loops against the wall of the Malpighian capsule, so that filtration cannot take place through them. It is not yet decided whether any fluid is given off through the convoluted urinary tubules.

As the blood-pressure in the renal artery is about 120–140 mm. Hg., and the urine in the ureter is moved along by a very slight propelling force, so that a counter-pressure of from 10 (Löbell) to 40 mm. of Hg. is sufficient to arrest its flow, it is clear that the blood-pressure can also act as a *vis a tergo* to propel the urine stream through the ureter. The pressure in the ureter is measured by dividing the ureter transversely and placing a manometer in it.

B. Secretory Activity of the Renal Epithelium.—*The degree of concentration of the urine* depends upon the quantity of the dissolved constituents which has passed from the blood into the water of the urine. The secretory cells of the convoluted tubules by their own proper vital activity, seem to be able to take up, or secrete, some, at

least, of these substances from the blood (Bowman, Heidenhain). The watery part of the urine, containing only easily diffusible salts, as it flows along the tubules from the glomeruli, extracts or washes out these substances from the secretory epithelium of the convoluted tubules. The following considerations attest the independent activity of the cells:—

1. Sulphindigotate of soda and sodium urate, when injected into the blood, pass into the urine, and are found within the protoplasm of the cells of the *convoluted tubules* [only in those parts lined by “rodged” or “fibrillated” epithelium], but not in the Malpighian capsules (Heidenhain). A little later, these substances are found in the *lumen* of the urinary tubules, from which they are washed out by the watery part of the urine coming from the glomeruli. If, however, two days before the injection of these substances into the blood, the cortical part of the kidney containing the Malpighian capsules be cauterised [*e.g.*, by nitrate of silver] (Heidenhain), or simply be removed with a knife (Hoegyes), the blue pigment remains within the convoluted tubules. It cannot be carried forward, as the water, which should carry it along, has ceased to be secreted, owing to the destruction of the glomeruli. This experiment also goes to show that, through the *glomeruli*, the *watery part* of the urine is *chiefly excreted*; while, through the *convoluted tubules*, the *specific urinary constituents* are excreted. *Uric acid salts*, injected into the blood, were observed by Heidenhain to be excreted by the convoluted tubules. Von Wittich had previously observed that in *birds*, crystals of uric acid were excreted by the epithelium of the convoluted tubules. [The presence of crystals of uric acid in the renal epithelium was observed by Bowman, and used as an argument to support his theory.] Nussbaum (1878) has proved that *urea* is secreted by the urinary tubules and not by the glomeruli.

The same is true for the *bile-pigments* (Möbius, 1877), for the *iron salts* of the vegetable acids when injected subcutaneously (Glaevecke), and for hæmoglobin (Landois). After the injection of *milk* into the blood-vessels, numerous fatty granules occur within the epithelium of the urinary tubules (§102).

[Nussbaum's Experiments.—In the frog and newt, the kidney is supplied with blood in a different manner from that obtaining in mammals. The glomeruli are supplied by branches of the renal artery. The tubules are supplied by the renal portal vein. The vein coming from the posterior extremities divides at the upper end of the thigh into two branches, one of which enters the kidney, and breaks up to form a capillary plexus which surrounds the uriniferous tubules, but this plexus is also joined by the efferent vessels of the glomeruli. These two systems are partly independent of each other. By ligaturing

the renal artery, Nussbaum found that the circulation to the glomeruli was cut off, while ligature of the renal portal vein excluded the functional activity of the tubules. By injecting a substance into the blood after ligaturing either the artery or renal portal vein, and observing whether it occurs in the urine, he infers that it is given off either by the glomeruli or the tubules. *Sugar* and *peptones* rapidly pass through an intact kidney, but if the renal artery be tied they are not excreted. *Urea* when injected into the circulation is excreted after the artery is tied, so that it is excreted through the tubules, but at the same time it takes with it a considerable quantity of water. Thus water is excreted in *two* ways from the kidney, by the glomeruli and also from the venous plexus around the tubules along with the urea. *Indigo-carmine* merely passes into the tubular epithelium of the convoluted tubules, but it does not cause a secretion of urine. *Albumin* passes through the glomeruli, but only after their membranes have been altered in some way, as by clamping the renal artery for a time.]

Excretion of Pigments.—Other observers, however, have found that colouring matter may be excreted through the glomeruli, especially if much sulphindigotate of soda be injected, and the experiment lasts for a long time. Arnold and Pautynski observed that the epithelium of the Malpighian capsule became blue. Henschen, who has observed a similar result, attributes the presence of the blue colour in a solid form in the convoluted tubules, to a reabsorption of water from the tubules into the blood, since the water secreted in the glomeruli contains such a quantity of urinary salts as to precipitate the colouring matter. [Klein found that when carmine is injected into the blood, it is excreted not through the substance of the epithelial cells, but through the cement substance *between* the cells.] According to Ludwig, the concentration of the urine occurs normally in the convoluted tubules, and hence most of the pigment occurs in them. Should an abnormal and partial absorption of water take place in the capsules, granular pigment may also be deposited in them. It is found in them when the pressure within the *vas afferens* is greatly diminished. In *albuminuria*, the abnormal excretion of albumin takes place first of all in the urinary tubules, and later, in the capsules (Senator). According to Nussbaum, egg-albumin is excreted through the capsules, and sometimes hæmoglobin has been found in them also (Grützner, Adams).

2. Even when the secretion of the *watery part* of the urine is completely *arrested*, either by ligature of the ureter, or after a very great fall of the blood-pressure in the renal artery [as after section of the cervical spinal cord], the before-mentioned substances, when injected into the blood, are found in the cells of the convoluted tubules. The injection of urea under these circumstances causes renewed secretion. These facts show that, independently of the filtration-pressure, the *secretory activity of these cells* is still maintained (Heidenhain, Neisser, Ustimowitsch, Grützner).

The independent *vital* activity of the secretory cells of the urinary tubules, which as yet we are unable to explain on purely physical grounds, renders it probable that the tubules are not to be compared to an apparatus provided with

physical membranes. This is proved by the following experiment:—Abeles caused arterial blood to circulate through freshly excised living kidneys. A pale urine-like fluid dropped from the ureter. On adding some urea or sugar to the blood, the secretion became more concentrated. Thus the excised living kidney also excretes substances in a more concentrated form than when supplied to it in the diluted blood streaming through it.

Salts and Gases.—The vital activity explains why the serum-albumin of the blood does not pass into the urine, while egg-albumin and dissolved hæmoglobin readily do so. Among the *salts*, which occur in the blood and blood-corpuscles, of course only those in solution can pass into the urine. Those which are united with proteid bodies, or are fixed in the cellular elements, cannot pass out, or at least only after they have been split up. Thus we may explain the difference between the salts of the urine and those of the blood. Similarly, the urine can only contain the absorbed and not the chemically-united *gases*.

Ligature of the Ureter.—If the secretion be arrested by compression or by ligature of the ureter, the lymph-spaces of the kidney become filled with fluid, which may pass into the blood, so that the organ becomes œdematous, owing to the passage of fluid into its lymph-spaces. The secretion undergoes a change, as first water passes back into the blood, then the sodic chloride, sulphuric, and phosphoric acids diminish, and lastly the urea (C. Ludwig, Max Herrmann). Kreatinin is still present in considerable amount. There is no longer secretion of proper urine (Löbell).

Non-Symmetrical Renal Activity.—It is remarkable that both kidneys do not secrete symmetrically—there is an alternate condition of hyperæmia and secretory activity on opposite sides (§ 100). One kidney secretes a more watery urine, which at the same time contains more NaCl and urea (Ludwig, M. Herrmann). Von Wittich observed that the excretion of uric acid was not uniform in all the urinary tubules of the same bird. Extirpation of *one* kidney, or disease of one kidney in man, does not seem to diminish the secretion (Rosenstein). The remaining kidney becomes more active and larger.

Reabsorption in the Kidney.—In discussing the secretion of the kidney, we must attach considerable importance to the variations in the calibre of the renal tubules in their course. Perhaps in the narrowing of the descending part of the looped tubule of Henle there may be either a reabsorption of water, so that the urine becomes more concentrated, or there may be absorption even of albumin, which may perhaps pass through the glomeruli in small amount.

[**Reabsorption in the Kidney.**—That reabsorption of fluid takes place within the kidney was part of Ludwig's theory, which is practically a process of filtration and reabsorption. Hüfner pointed out that the structure of the kidneys of various classes of vertebrates corresponded closely with the requirements for reabsorption of water. The experiments of Ribbert show that the urine actually secreted in the cortex of the kidney is more watery than that secreted normally by the entire organ. He extirpated the medullary portion in rabbits, leaving the cortical part intact, and in this way collected the dilute urine from the Malpighian corpuscles before it passed through Henle's loops.]

274. The Preparation of the Urine.

The question has often been discussed, whether all the urinary constituents are merely excreted through the kidneys, *i.e.*, that they exist

pre-formed in the blood; or whether some of them do *not* exist pre-formed in the blood, but are formed within the kidneys, as a result of the activity of the renal epithelium. The following considerations give at least an indication regarding the solution of such a problem:—

1. The blood contains one part of urea in 3000–5000 parts (Fr. Simon, 1841), but the renal vein contains less urea than the blood of the corresponding artery (Picard, 1856, Gréhant). This fact is in favour of the excretion of urea from the blood.

2. After extirpation of the kidneys, or nephrotomy (Prévost and Dumas), or after ligation of the renal vessels, the amount of urea accumulates in the blood (Meissner, v. Voit), and increases with the duration of the experiment to $\frac{1}{3000}$ to $\frac{1}{4000}$ (Gréhant). At the same time, there is vomiting and diarrhoea, and the fluids so voided contain urea (Cl. Bernard, Bareswill). Animals die in from one to three days after the operation.

3. After ligation of the ureters, the secretion of urine is soon arrested. Urea accumulates in the blood, but not to a greater extent than after nephrotomy. It is possible, however, that the kidneys, like other organs, may form a small amount of urea, due to the metabolism of their own tissues.

4. Birds' blood normally contains uric acid (Meissner). Ligation of their ureters or blood-vessels (Pawlinoff), or the gradual destruction of their secretory parenchyma by the subcutaneous injection of neutral potassium chromate (Elstein), is followed by the deposition of uric acid in the joints and tissues, and it may even form a white incrustation on the serous membranes. The brain remains free (Galvani, 1767, Zalesky, Oppler). Acid urates of ammonia, soda, and magnesia are also similarly deposited (Colasanti). Extirpation of a snake's kidneys gives the same result, but to a less degree.

These experiments go to show that at least some of the *urea*—perhaps the most part—and some other substances are *excreted* by the kidneys, and that they are not formed in these organs. These substances seem to be formed in the tissues, the urea being derived from the decomposition of albumin, perhaps chiefly in the *liver* and in the lymph-glands. Von Schröder and Colasanti, as the result of their experiments upon snakes, come to the conclusion that there is no special organ concerned in the formation of uric acid. Urobilin is derived from hæmoglobin (§ 261).

Physiological and Chemical Processes.—We know very little of the physiological chemical processes which take place in the kidneys. Hippuric acid is formed in the kidney, for the blood of herbivora does not contain a trace of it (Meissner and Shepard). In rabbits, perhaps it is formed synthetically, in other tissues as well as in the kidney. If blood containing sodic benzoate and glycin be passed through the blood-vessels of a fresh kidney, hippuric acid is formed (§ 260) (Bunge, Schmiedeberg, Kochs). If *phenol* and pyrokatechin are digested along with fresh renal substance, a compound of sulphuric acid similar to that occurring in urine (§ 262) is formed. The latter substance, however, is also formed by similarly digesting liver, pancreas, and muscle. It is concluded from these experiments that these substances are formed in the body within the kidneys, and the other organs mentioned (Kochs).

Chemistry of the Kidney.—The kidneys contain a very large amount of *water*.

Besides serum-albumin, globulin, albumin soluble in sodium carbonate (Gottwalt), gelatin-yielding substances, fat in the epithelium, elastic substance derived from the *membrana propria* of the tubules, the kidneys contain leucin, xanthin, hypoxanthin, kreatin, taurin, inosit, cystin (the last in no other tissue), but only in very small amount.

The occurrence of these substances points to a lively metabolism in the kidneys, which is also proved by the liberal supply of blood they receive.

Blood-Vessels.—The kidneys receive a very large supply of blood, and during secretion, the blood of the *renal vein* is *bright red* (Cl. Bernard). [In the dog, the diameter of the renal artery may be diminished to .5 mm. without the amount of blood flowing through the kidney being thereby greatly interfered with. Hence, within wide limits, the amount of blood is independent of the size of the arterial lumen, and is therefore dependent on the blood-pressure in the aorta, and the resistance to the blood-current within and beyond the kidney (Heidenhain).]

The *reaction* of the kidney is *acid*, even in those animals whose urine is alkaline. Perhaps this fact is connected with the retention of the albumin in the vessels (Heynsius).

275. Passage of Various Substances into the Urine.

1. The following substances pass *unchanged* into the urine:—Sulphate, borate, silicate, nitrate, and carbonate of the alkalies; alkaline chlorides, bromides, iodides; potassium sulpho-cyanide, and ferrocyanide; bile salts, urea, kreatinin; cumaric, oxalic, camphoric, pyrogallic and carbolic acids. Many *alkaloids*, e.g., morphia, strychnia, curara, quinine, caffeine; *pigments*, sulphindigotate of soda, carmine, madder, logwood, colouring matter of cranberries, cherries, rhubarb; santonin; lastly, salts of gold, silver, mercury, antimony, arsenic, bismuth, iron (but not lead), although the greatest part of these is excreted by the bile and the *fæces*.

2. Inorganic acids reappear in man and carnivora as neutral salts of ammonia (Schmiedeberg and Walter, Hallervorden); in herbivora, as neutral salts of the alkalies (E. Salkowski).

3. Certain substances which, when injected in small amount, seem to be decomposed in the blood, pass in part into the urine, when they occur in such large amount in the blood that they cannot be completely decomposed—sugar, hæmoglobin, egg-albumin, alkaline salts of the vegetable acids, alcohol, chloroform.

4. Many substances appear in an *oxidised form* in the urine—moderate quantities of vegetable alkaline salts as alkaline carbonates (Wöhler), uric acid in part as allantoin (Salkowski), sulphides and sulphites of soda, in part as sodium sulphate, potassium sulphide as potassium sulphate.

5. Those bodies which are completely decomposed, as glycerin, camphor, resins, give rise to no special derivatives in the urine.

6. Many substances *combine* and appear as conjugated compounds in the urine, e.g., the origin of hippuric acid by conjugation (§ 260), the conjugation of sulphuric acid (§ 262), and the formation of urea by synthesis from carbamic acid and ammonia (Drechsel) (§ 256).

7. Tannic acid, $C_{14}H_{10}O_9$ takes up H_2O , and is decomposed into two molecules of gallic acid = 2 ($C_7H_6O_5$).

8. The iodates of potash and soda are *reduced* to iodides; malic acid ($C_4H_6O_5$) partly to succinic acid ($C_4H_6O_4$); indigo-blue ($C_{16}H_{10}N_2O_2$) takes up hydrogen and becomes indigo-white ($C_{16}H_{12}N_2O_2$).

9. Some substances do not pass into the urine at all, *e.g.*, oils, insoluble metallic salts and metals.

276. Influence of Nerves on the Renal Secretion.

At the present time we are acquainted merely with the influence of the *vaso-motor* nerves on the *filtration* of the urine through the renal vessels. *Each* kidney seems to be supplied with vaso-motor nerves, which spring from *both* halves of the spinal cord (Nicolaides). As a general rule, dilatation of the branches of the renal artery, chiefly the vasa afferentia, must raise the pressure within the glomeruli, and thus increase the amount of water filtered through them. The more the dilatation is confined to the area of the renal artery alone, the greater is the amount of the urine. [As yet we only know that, the nervous system influences the secretion of urine only in so far as it modifies the pressure and velocity of the blood-current in the kidney. We have no satisfactory evidence of the existence of direct secretory nerves in the kidney.]

1. **Renal Plexus and its Centre.**—Section of the nerves of the renal plexus—the nerves around the renal artery—generally causes an increase in the secretion of urine [*hydruria* or *polyuria*]; sometimes on account of the great rise of the pressure within the glomeruli, albumin passes into the urine (and there may be rupture of the vessels of the glomeruli), leading to the passage of blood into the urine (Krimmer, J. Müller). The *nerve-centre* for these renal nerves lies in the floor of the fourth ventricle, in front of the origin of the vagus. Injury to this part of the floor of the fourth ventricle, *e.g.*, by puncture (*piqûre*), may increase the amount of urine (*diabetes insipidus*), which is sometimes accompanied by the simultaneous appearance of albumin and blood in the urine (Cl. Bernard). Section of the parts which lie directly in the course of these fibres, as they pass from the centre in the medulla to the kidney, produces the same effects. Close to this centre in the medulla, there lies the centre for the vaso-motor nerves of the liver, whose injury causes *diabetes mellitus* (grape-sugar in the urine, § 175). Eckhard found that, stimulation of the vermiform process of the cerebellum produced *hydruria*. In man, stimulation of these parts by tumours or inflammation, etc., produces similar results.

2. **Paralysis of Limited Vascular Areas.**—If, simultaneously with the paralysis of the nerves of the renal artery, the nerves of a neighbouring large vascular area be paralysed, necessarily the blood-pressure in the

renal artery area will not be so high, as more blood flows into the other paralysed province. Under these circumstances, there may be only a temporary or, indeed, no increase of urine, provided the paralysed area be sufficiently large. There is a moderate increase of urine for several hours after section of the *splanchnic nerve*. This nerve contains the renal vaso-motor nerves (which, in part at least, leave the spinal cord at the first dorsal nerve and pass into the sympathetic nerve), but it also contains the vaso-motor nerves for the large area of the intestinal and abdominal viscera. Stimulation of this nerve has the opposite effect (Cl. Bernard, Eckhard). [The polyuria thus produced is not so great as after section of the renal nerves, because the splanchnic supplies such a large vascular area, that much blood accumulates in that area, and also because all the renal nerves do not run in the splanchnics.]

3. Paralysis of Large Areas.—If, simultaneously with paralysis of the renal nerves, the great majority of the vaso-motor nerves of the body be paralysed, [as by section of the medulla oblongata, p. 575], then, owing to the great dilatation of all these vessels, the blood-pressure falls at once throughout the entire arterial system. The result of this may be, provided the pressure is sufficiently low, that there is a great decrease, or, it may be, entire cessation of the secretion of urine. The secretion is arrested when the cervical cord is completely divided, down even as far as the seventh cervical vertebra (Eckhard). The polyuria caused by injury to the floor of the fourth ventricle, at once disappears, when the spinal cord (even down to the twelfth dorsal nerve) is divided.

[As already stated, section of the renal nerves is followed by polyuria, owing to the increased pressure in the glomeruli, but this polyuria may be increased by stimulating the spinal cord below the medulla oblongata, because the contraction of the blood-vessels throughout the body still further raises the blood-pressure within the glomeruli. If, however, the spinal cord be divided below the medulla oblongata—the renal nerves being also divided—the polyuria ceases, because of the fall of the general blood-pressure thereby produced. Merely dividing the spinal cord in the dorsal region also diminishes or arrests the secretion of urine, owing to the fall of the blood-pressure, but animals recover from this operation, the general blood-pressure rises, and with it the secretion of urine. Stimulation of the cord below the medulla arrests the secretion, as it causes contraction of the renal arteries along with the other arteries of the body.]

[Volume of the Kidney—Oncometer.—By means of the plethysmograph (§ 101) we can measure the variations in the size of a limb, while by the oncograph (ὄγκος, volume) similar variations in the volume of the spleen (§ 103) are measured. Roy and Cohnheim

have measured the variations in the volume of the kidney by means of an instrument which consists of two parts, one termed the *oncometer* or *renal plethysmometer*, in which the organ is enclosed, while the other part is the registering portion or *oncograph*. The kidney is enclosed in a metallic capsule shaped like the kidney (Fig. 218), and it is composed of two halves which move on a hinge, *h*, to introduce the organ. The renal vessels pass out at *a, v*. The kidney is surrounded with a thin membrane, and between this membrane and the inner surface of the capsule is a space filled with warm oil through the tube, *I*, which is closed by means of a stop-cock after the space is filled with oil. The tube, *T*, can be made to communicate with another tube, *T*₁, leading into a metallic chamber, *C*¹, of the *oncograph* (Fig. 219), which is provided with a movable piston, *p*, attached by a thread to the writing-lever, *l*. Any increase in the size of the organ expels oil from the chamber, *O*, into *C*¹, and thus the piston is raised, while a diminution in the size of the kidney diminishes the fluid in *C*¹ and the lever falls. The actual

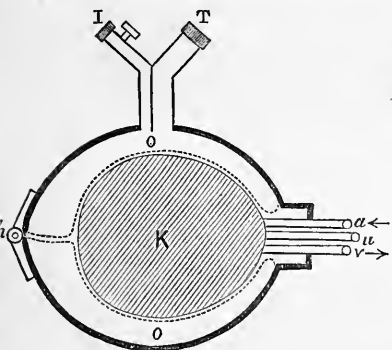

Fig. 218.

Oncometer—K, kidney; the thick line is the metallic capsule; *h*, hinge; *I*, tube for filling apparatus; *T*, tube to connect with *T*₁; *a, v, u*, artery, vein, ureter (Stirling, after Roy).

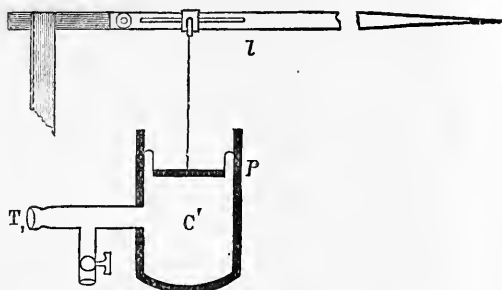

Fig. 219.

Oncograph—*C*, chamber filled with oil, communicating by *T*₁ with *T*; *p*, piston; *l*, writing-lever (Stirling, after Roy).

volume of the living kidney depends upon the state of distension of its structural elements, upon the amount of lymph in its lymph-spaces, but chiefly upon the amount of blood in its blood-vessels, and this again must depend upon the condition of the non-stripped muscles in the renal arteries. When the vessels dilate, the kidney will increase in size, and when they contract it contracts, so that we can register, on the same revolving cylinder, the variations of the volume at the same time that we record the general arterial blood-pressure.]

[In the **normal circulation** through the kidney, the kidney-curve, *i.e.*, the curve of the volume of the kidney runs quite parallel with the blood-pressure curve, and shows exactly the large respiratory undulations, as well as the smaller elevations due to the systole of the heart (Fig. 220). Usually, when the blood-pressure falls, the kidney-curve sinks, and when the blood-pressure rises, the volume of the kidney increases. When the blood-pressure curve is complicated by Traube-Hering waves (p. 171) the *opposite* effect is produced on the kidney-curve; the highest blood-pressure corresponds to the smallest size of the kidney, and conversely. This is due to the fact that, when these curves occur, all the small arterioles, including those in the kidney, are contracted. A kidney placed in an oncometer secretes urine like a kidney under natural conditions.]



Fig. 220.

B P, Blood-pressure curve; K, curve of the volume of the kidney; T, time curve; intervals indicate a quarter of a minute; A, abscissa (Stirling, after Roy).

[*Arrest of the respiration* in a curarised animal produces a rapid and great diminution of the volume of the kidney, caused by the venous blood stimulating the vaso-motor centres, and thus contracting the small arterioles, including those of the kidney. This result occurs whether one or both splanchnics are divided, proving that all the vaso-motor nerves of the kidney do not reach it through the splanchnics. When *all* the renal nerves at the hilum are divided, arrest of the respiration causes dilatation of the organ, which condition runs parallel with the rise of the blood-pressure. Stimulation of a sensory nerve, *e.g.*, the central end of the sciatic nerve, while causing an increase of the blood-pressure, makes the kidney shrink.]

[In poisoning with *strychnin*, the kidney shrinks while the blood-pressure rises. Stimulation of the central or peripheral end of the *splanchnics*, divided at the diaphragm, causes contraction of the renal vessels of *both* sides; the former is a reflex, the latter a direct effect. Stimulation of the peripheral end of *one* splanchnic sometimes affects both kidneys. Stimulation of the peripheral end of the renal nerves always causes a diminution in the volume of the kidney, so that

Cohnheim and Roy were forced to conclude that, although there was evidence of the existence of vaso-motor and sensory nerves to the kidney, they found none of vaso-dilator nerves. By the same method, Cohnheim and Roy confirmed absolutely the independent action of the two kidneys. The sudden compression of one renal artery had not the slightest effect upon the blood-current of the other kidney. If a kidney be exposed in an animal, by making an incision in the lumbar region, on stimulating the medulla oblongata directly with electricity, we may observe the kidney itself becoming paler, the palor appearing in a great many small spots on the surface of the organ corresponding to the distribution of the interlobular arteries.]

[The researches of Cohnheim have shown that, the *composition of the blood* has a remarkable effect on the renal circulation. Some substances (water and urea), when injected into the blood, cause the kidney first to shrink and then to expand, while sodic acetate dilates the kidney, even after all the renal nerves are divided—an operation which is very difficult indeed. Provided all the renal nerves be divided, these effects would indicate the existence of some local intra-renal vaso-motor mechanism governing the renal blood-vessels. The general blood-pressure is not thereby modified; nor need we wonder at this, as ligature of one renal artery does not increase the pressure in the aorta.]

Mosso also showed that the blood-stream through an excised organ was materially influenced by the substances mixed with the blood perfused. This effect may in part be due to the action of these chemical ingredients upon the nuclei of the endothelial lining of the blood-vessels, especially the capillaries.

[The reciprocal relation between the *skin and the kidneys* is known to every one. On a cold day, when the skin is pallid, owing to contraction of the cutaneous vessels, the amount of urine secreted is great, and conversely, in summer less urine is passed than in winter. Washing the skin of a dog for two minutes with ice-cold water causes a great contraction of the kidney.]

[Strychnin seems to be able to cause contraction of the renal vessels independently of its action on the general vaso-motor centre. Brunton and Power found that, digitalis caused an increase of the blood-pressure (dog), but the secretion of urine was either at the same time diminished, or it ceased altogether. The latter result was due to contraction of the renal blood-vessels, but when the aortic blood-pressure began to fall, the amount of urine secreted rose much above normal—i.e., when the arteries had begun to relax.]

During *fever*, the renal vessels are probably contracted in consequence of the stimulation of the renal centre by the abnormally warm blood (Mendelson).

The repeated respiration of CO is said to produce polyuria, perhaps in consequence of paralysis of the renal vaso-motor centre.

Action of the Vagus.—According to Cl. Bernard, stimulation of the vagus at

the cardia increases the urinary secretion, while at the same time, the blood of the renal vein becomes red. It is possible that this nerve may contain vaso-dilator nerve-fibres corresponding to the fibres in the facial nerve for the salivary glands (§145).

277. Uræmia—Ammoniæmia.

Symptoms of Uræmia.—After excision of the kidneys (nephrotomy), or ligature of the ureter, whereby the secretion of urine is arrested; in man also, as a result of certain diseased conditions of the kidney leading to the suppression of the secretion of urine, there is developed a series of characteristic symptoms which are followed by death. The condition is called uræmic intoxication or *uræmia*. Besides marked brain phenomena, drowsiness, and even deep coma, there are occasional local or more general *spasms*. Sometimes there is *delirium*; Cheyne-Stokes' phenomenon is often observed (§111, II.), and there may be vomiting and diarrhœa, while in the fluids voided, as well as in the expired air, ammonia may sometimes be detected.

The cause of these phenomena has been ascribed to the retention in the blood of those substances which normally are excreted by the urine, but as yet it has not been definitely ascertained which of these substances cause the phenomena:—

1. The first thought is to ascribe them to the retention of the *urea*. v. Voit found that dogs exhibited uræmic symptoms if they were fed for a long time on food containing urea and little water. Meissner found that in nephrotomised animals, the uræmic symptoms were hastened by the injection of urea into the blood. The injection of a moderate amount of urea, in perfectly sound animals, is not followed by uræmic symptoms, probably because the urea is rapidly excreted by the kidneys; 1-2 grammes [15-30 grains] so injected produce comatose symptoms in rabbits.

2. The injection of **ammonium carbonate** produces symptoms resembling those of uræmia, so that v. Frerichs and Stannius thought that the urea was decomposed in the blood, yielding ammonium carbonate—*ammoniæmia*. Demjankow observed uræmic phenomena after nephrotomy, when at the same time he injected the urea-ferment (§ 263) into the blood. Feltz and Ritter obtained uræmic symptoms in dogs by injecting salts of ammonia.

3. As ligature of the ureters produces a comatose condition in those animals, which excrete chiefly uric acid in the urine—*e.g.*, birds and snakes (Zalesky)—it is possible that other substances may produce the poisonous symptoms. The injection of kreatinin causes feebleness and contraction of the muscles in dogs (Meissner). Bernard, Traube, and more recently Feltz and Ritter, ascribe the symptoms to an accumulation of the neutral potassium salts in the blood (§ 54). The injection of kreatin, succinic acid (Meissner), uric acid, and sodic urate (Ranke) is without effect.

Schottin and Oppler ascribe the results to an accumulation of normal or abnormal *extractives*. It is possible that several substances and their decomposition products (v. Voit, Perls) contribute to produce the result, so that there is a combined action of several factors, but perhaps the retention of the *potash salts* plays the most important part.

Human urine, when injected under the skin of frogs or rabbits, acts as a poison, and even causes death (Cl. Bernard, Bocci).

Ammoniæmia.—When urine undergoes the alkaline fermentation within the bladder, and ammonium carbonate is formed, the ammonia may be absorbed and produce this condition. The breath and excretions smell strongly of ammonia; the mouth, pharynx, and skin are very dry; there is vomiting, with diarrhœa or

constipation, while ulcers may form in the intestine (Treitz). The patient rapidly loses flesh, and death occurs without any disturbance of the mental faculties.

Uric Acid Diathesis.—When too much nitrogenous food, too much alcoholic fluids are persistently used, and little muscular exercise taken, especially if the respiratory organs are interfered with, uric acid may not unfrequently accumulate in the blood (Garrod). It may be deposited in the joints and their ligaments, especially in the foot and hand, giving rise to painful inflammation, and forming gout-stones or chalk-stones. The heart, liver, and kidneys are rarely affected. The tissues near these deposits undergo necrosis.

278. Structure and Functions of the Ureter.

Mucous Membrane.—The pelvis of the kidney and the ureter are lined by a *mucous membrane*, consisting of connective-tissue, and covered with several layers of stratified “*transitional*” epithelium (Fig. 221). The cells are of various shapes, those of the lowest layer being usually more or less spherical and small, while many of the cells in the upper layers are irregular in shape, often with long processes passing into the deeper layers.

Sub-mucosa.—Under the epithelium there is a layer of adenoid tissue (Hamburger, Chiari), which may contain small lymph-follicles [embedded in loose connective-tissue]. There are a few small mucous glands in the pelvis of the kidney, and also in the ureter (Unruh, Egli). [They are lined by a single layer of columnar epithelium.]

The **muscular coat** consists of an inner somewhat stronger layer of *longitudinal* non-stripped fibres, and an outer *circular* layer. In the lowest third of the ureter there are, in addition, a number of scattered muscular fibres. All these layers are surrounded and supported by connective-tissue. The outer layers of the connective-tissue form an outer coat or **adventitia**, which contains the large vessels and nerves [with small ganglia]. The various coats of the ureter can be followed up to the pelvis of the kidney and to its calices. The papillæ are covered only by the mucous membrane, while the muscular layer ceases at the apex of the pyramids, where they are disposed circularly, to form a kind of *sphincter* muscle for each papilla (Henle).

The **blood-vessels** supply the various coats, and form a capillary plexus under the epithelium.

The **nerves** are not very numerous, but they contain medullated (few) and non-medullated fibres with numerous ganglia scattered in their course. They are partly *motor*, and supply the muscular layers, and some pass towards the epithelium, and are *sensory* and *excito-reflex* in function. It is these nerves which are excited when a calculus, passing along the ureter, gives rise to severe pain. The ureter perforates the wall of the bladder *obliquely*. The inner opening is a narrow slit in the mucous membrane, directed downwards and inwards, and provided with a pointed valve-like process (Fig. 222).

Movement of the Urine.—The urine is propelled along the ureter thus:—(1) The secretion, which is continually being formed under a high pressure in the kidney, propels onwards the urine in front of it, as the urine is under a low pressure in the ureter. (2) *Gravity* aids the passage of the urine when the person is in the erect posture. (3) The muscles of the ureter contract rhythmically and peristaltically, and so propel it towards the bladder. This movement is reflex, and is due to the presence of the urine in the ureter.

Every three-quarters of a minute several drops of urine pass into the bladder (Mulder). But the fibres may also be excited directly. The contraction passes along the tube at the rate of 20–30 mm. per second, always from above downwards. The greater the tension of the ureter due to the urine, the more rapid is the peristaltic movement (Sokoleff and Luchsinger).

Local Stimulation.—On applying a stimulus to the ureter directly, the contraction passes both upwards and downwards. Engelmann observed that these movements occur in parts of the ureter where neither nerves nor ganglia were to be found, and he concluded that the movement was propagated by “muscular conduction.” If this be so, then an impulse may be propagated from one non-striated muscular cell to another without the intervention of nerves (compare the same result in the heart, § 58, I., 3, p. 101).

Prevention of Reflux.—The urine is prevented from exerting a backward pressure towards the kidneys, thus:—1. The urine which collects in the pelvis of the kidney is under a high pressure, and thus tends uniformly to compress the pyramids, so that the urine cannot pass into the minute orifices of the urinary tubules (E. H. Weber). 2. When there is a considerable accumulation of urine in a ureter, *e.g.*, from the presence of an impacted calculus or other cause, there is also more energetic peristalsis, and, at the same time, the circular muscular fibres round the apices of the pyramids, compress the pyramids and prevent the reflux of urine through the collecting tubules. The urine is prevented from passing back from the bladder into the ureter, by the fact that, when the bladder is greatly distended with urine, the wall of the bladder itself, and the part of the ureter which passes through it, are compressed, so that the edges of the slit-like opening (Fig. 222) of the ureter are rendered more tense, and are thus approximated towards each other.

279. Urinary Bladder and Urethra.

Structure.—The mucous membrane of the bladder resembles that of the ureter; the upper layers of the stratified transitional epithelium are flattened. It is obvious that the form of the cells must vary with the state of distension or contraction of the bladder. [The mucous membrane and muscular coats are thicker than in the ureter. There are mucous glands in the mucous membrane, especially near the neck of the bladder.]

Sub-mucous Coat.—There is a layer of delicate fibrillar connective-tissue mixed with elastic fibres between the mucous and muscular layers.

[The **serous Coat** is continuous with, and has the same structure as, the peritoneum, and it covers only the posterior and upper half of the organ.]

Musculature.—The *non-stripped* muscular fibres are arranged in bundles in several layers, an *external longitudinal* layer best developed on the anterior and posterior surfaces, and an *inner circular* layer. [Between these two is an *oblique* layer.]

There are other bundles of muscular fibres arranged in different directions.

Physiologically, the musculature of the bladder represents a single or common hollow muscle, whose function, when it contracts, is to diminish uniformly the size of the bladder, and thus to expel its contents (§ 306).

The **blood-vessels** resemble those of the ureter. The **nerves** form a plexus, and are placed partly in the mucous membrane and partly in the muscular coat, and, like all the extra-renal parts of the urinary apparatus, are provided with

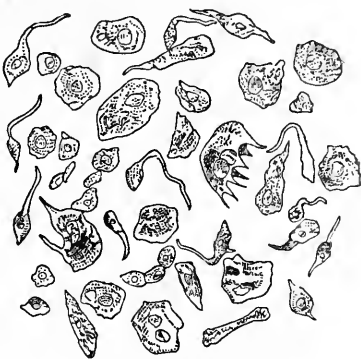

Fig. 221.

Transitional epithelium from the bladder. Many of the large cells lie upon the summit of the columnar and caudate cells, and depressions are seen on their under surface (after Beale).

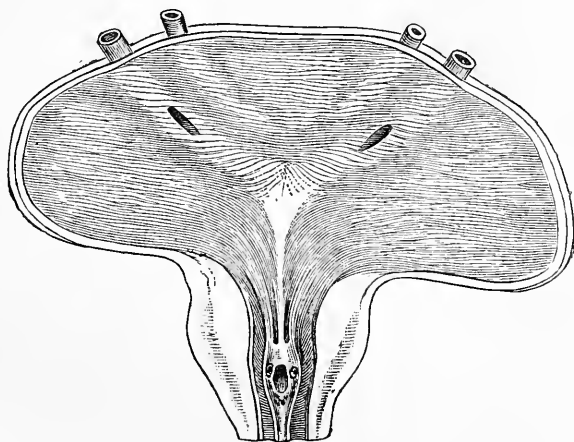

Fig. 222.

Lower part of the human bladder laid open, with the lower ends of the ureters. Note the clear part, the trigone, the slit-like openings of the ureters, the divided ureters, and vesiculæ seminales; the sinus prostaticus, and on each side of it, the round openings of the ejaculatory ducts, and below both the numerous small apertures of the ducts of the prostate gland.

ganglia, some of these lying in the mucosa, others in the sub-mucosa, and connected to each other by fibres (Maier). Ganglia occur in the course of the motor

nerve-fibres in the bladder (W. Wolff). Their functions are motor, sensory, excitomotor, and vaso-motor. [Sympathetic nerve-ganglia also exist underneath the serous coat (F. Darwin).]

A too minute dissection of the several layers and bundles of the musculature of the bladder has given rise to erroneous inferences. Thus, we speak of a special *detrusor urinae*, which, however, consists chiefly of fibres running on the anterior and posterior surfaces from the vertex to the fundus. There does not seem to be a special *sphincter vesicæ internus*; it is merely a thicker circular (6–12 mm.) layer of non-striated muscle which surrounds the beginning of the urethra, and which, from its shape, helps to form the funnel-like exit of the bladder. Numerous muscular bundles, connected partly with the longitudinal and partly with the circular fibres of the bladder, exist, especially in the trigone, between the orifices of the ureters.

Sphincter Urethræ.—The proper sphincter urethræ is a *transversely striped* muscle subject to the will, and consists of completely circular fibres which extend downwards as far as the middle of the urethra, and partly of longitudinal fibres, which extend only on the posterior surface towards the base of the bladder, where they become lost between the fibres of the circular layer (Henle).

In the male urethra, the *epithelium* of the prostatic part is the same as that in the bladder; in the membranous portion it is stratified, and in the cavernous part, the simple cylindrical form. The mucous membrane, under the epithelium itself, is beset with *papillæ*, chiefly in the posterior part of the urethra, and contains the mucous glands of Littre.

Non-striated muscle occurs in the prostatic part arranged longitudinally, chiefly at the colliculus seminalis; in the membranous portion, the direction of the fibres is chiefly circular, with a few longitudinal fibres intercalated; the cavernous part has a few circular fibres posteriorly, but anteriorly the muscular fibres are single and placed obliquely and longitudinally.

Closure of the Bladder.—As to the means by which the male urethra is kept closed, it must be remembered that the so-called internal vesical sphincter of the anatomists, which consists of non-striated muscle, is in reality an integral part of the muscular coat of the bladder and surrounds the orifice of the urethra as far down as the prostatic portion, just above the colliculus seminalis. It is, however, not the sphincter muscle. The proper *sphincter urethræ* (*sph. vesicæ externus*) lies below the latter. It is a completely circular muscle disposed around the urethra, close above the entrance of the urethra into the septum urogenitale at the apex of the prostate, where it exchanges fibres with the deep transverse muscle of the perinæum which lies under it.

Some longitudinal fibres, which run along the upper margin of the prostate from the bladder, belong to this sphincter muscle. Single, transverse bundles passing forward from the surface of the neck of the bladder, the transverse bands which lie within the prostate opposite the apex of the colliculus seminalis, and a strong transverse bundle passing in front of the origin of the urethra into the substance of the prostate—all belong to the sphincter-muscle (Henle). In the male urethra, the *blood-vessels* form a rich capillary plexus under the epithelium, below which is a wide-meshed *lymphatic* plexus.

280. Accumulation and Retention of Urine— Micturition.

After emptying the bladder, the urine slowly collects again, the bladder being thereby gradually distended. As long as there is a moderate amount of urine in the bladder, the elasticity of the elastic fibres surrounding the urethra, and that of the sphincter of the urethra (and in the male of the prostate) suffice to retain the urine in the bladder. This is shown by the fact that, the urine does not escape from the bladder after death.

If the bladder is greatly distended (1·5–1·8 litre), so that its apex projects above the pubes, then its walls being distended cause a gentle stimulation of their sensory nerves (feeling of a full bladder), while, at the same time, the urethral opening is thereby dilated, so that a few drops of urine pass into the beginning of the urethra.

Besides the subjective feeling of a full bladder, this tension of the walls of the bladder causes a *reflex* effect, so that the urinary bladder contracts periodically upon its fluid contents, so do the sphincter of the urethra and the muscular fibres of the urethra, and thus the urethra is closed against the passage of these drops of urine. As long as the pressure within the bladder is not very high, the reflex activity of the transversely-striped sphincter overcomes the other (as during sleep); but, as the pressure rises and the distension increases, the contraction of the walls of the bladder overcomes the closure produced by the sphincter, and the bladder is emptied, as occurs normally in young children.

Slight movements confined to the bladder, occur during psychical or emotional disturbances (*e.g.*, anger, fear) [the bladder may be emptied involuntarily during a fright], after stimulation of sensory nerves (P. Bert, v. Basch, Meyer), auditory impressions, restraining the respiration, and by arrest of the heart's action. There are slight periodic variations coincident with variations in the blood-pressure. The contractions of the bladder cease after deep inspiration, and also during apnœa (Mosso and Pellacani). The excised bladder of the frog, and even portions free from ganglia, exhibit rhythmical contractions, which are increased by heat (Pfalz).

As age advances, the sphincter urethræ comes under the control of the will, so that it can be contracted voluntarily, as occurs in man when he forcibly contracts the bulbo-cavernosus muscle to retain urine in the bladder. The sphincter usually contracts at the same time. The reflex activity of the sphincter may also be inhibited voluntarily, so that it may be completely relaxed. This is the condition when the bladder is emptied voluntarily.

Nerves.—The nerves concerned in the retention and evacuation of the

urine are :—1. The *motor* nerves of the sphincter urethræ, which lie in the pudendal nerve (anterior roots of the third and fourth sacral nerves). When these nerves are divided, as soon as the bladder becomes so distended as to dilate the urethral opening, the urine begins to trickle away (incontinence of urine). 2. The *sensory nerves of the urethra*, which excite these reflexes, leave the spinal cord by the posterior roots of the third, fourth, and fifth sacral nerves. Section of these nerves also causes incontinence of urine. The *centre* in dogs lies opposite the fifth, and in rabbits, opposite the seventh, lumbar vertebra (Budge). 3. Fibres pass from the cerebrum—those that convey voluntary impulses through the peduncles, and the anterior columns of the spinal cord (according to Mosso and Pellacani, through the posterior columns and the posterior part of the lateral columns), to the motor fibres of the sphincter urethræ. 4. The *inhibitory fibres* concerned in the reflex-inhibition of the sphincter urethræ, take the same course (perhaps from the optic thalamus?) downwards through the cord to where the third, fourth, and fifth sacral nerves leave it. 5. Sensory nerves proceed from the urethra and bladder to the brain, but their course is not known. Some of the motor and sensory fibres lie for a part of their course in the sympathetic.

Transverse section of the spinal cord above where the nerves leave it, is always followed in the first instance, by retention of urine, so that the bladder becomes distended. This occurs because—1, the section of the spinal cord increases the reflex activity of the urethral sphincter; and, 2, because the inhibition of this reflex can no longer take place. As soon, however, as the bladder becomes so distended, as in a purely mechanically manner to cause dilatation of the urethral orifice, then the urine trickles away, but the amount of urine which trickles out in drops, is small. Thus the bladder becomes more and more distended, as the continuously distended walls of the organ yield to the increased tension, so that the bladder may become distended to an enormous extent. The urine very frequently becomes ammoniacal, and there results catarrh and inflammation of the bladder (p. 550, § 263).

Voluntary Micturition.—Observers are not agreed as to the mechanism concerned in emptying the bladder, when it is only partially full. It is stated by some that, a voluntary impulse passes from the brain along a cerebral peduncle, the anterior columns of the cord and the anterior roots of the third and fourth sacral nerves, and partly through motor fibres from the second to the fifth lumbar nerves (specially the third), to act directly upon the smooth muscular fibres of the bladder. This is assumed, because electrical stimulation of any part of this nervous channel causes contraction of the bladder. This view, however, does not seem to be the true one. It is to be remembered that

Budge showed that the sensory nerves of the wall of the bladder are contained in the first, second, third and fourth sacral nerves, and also in part, in the course of the hypogastric plexus, from whence they ultimately pass by the rami communicantes into the spinal cord.

According to Landois, the smooth musculature of the bladder cannot be excited directly by a voluntary impulse, but is always caused to contract reflexly. If we wish to micturate when the urinary bladder contains a small quantity of urine, we first excite the sensory nerves of the opening of the urethra, either by causing slight contractions of the sphincter urethræ, or by means of slight abdominal pressure, and thus force a little urine into the urethral orifice. This sensory stimulation causes a reflex contraction of the walls of the urinary bladder. At the same time, this condition is maintained voluntarily, by the action of the intra-cranial reflex-inhibitory centre of the sphincter urethræ. The *centre* for the reflex stimulation of the movements of the *walls of the urinary bladder* is placed somewhat higher in the spinal cord than that for the sphincter urethræ. In dogs, it is opposite the fourth lumbar vertebra (Gianuzzi, Budge).

Painful stimulation of sensory nerves causes reflex contraction of the bladder and evacuation of the urine (in children during teething). Reflex contraction of the bladder can be brought about in cats, by stimulation of the inferior mesenteric ganglion. After section of all the nerves going to the bladder, hæmorrhage and asphyxia cause contraction by a direct effect upon the structures in the wall of the bladder. As yet no one has succeeded in exciting artificially the inhibitory centre in the brain, for the sphincter muscle (Sokowin and Kowalewsky).

It seems probable that, as in the case of the anal sphincter (§ 160), there is not a *continuous tonic* reflex stimulation of the sphincter urethræ; the reflex is excited each time by the contents. 2. The sphincter vesicæ of the anatomists, which consists of smooth muscular tissue, does not seem to take part in closing the bladder. Budge and Landois found that, after removal of the transversely striped sphincter urethræ, stimulation of the smooth sphincter did not cause occlusion of the bladder, nor could L. Rosenthal or v. Wittich convince themselves of the presence of tonus in this muscle. Indeed, its very existence is questioned by Henle.

Changes of the Urine in the Bladder.—When the urine is retained in the bladder for a considerable time, according to Kaupp, there is an increase in the sodium chloride and a decrease in the urea and water. Urine which remains for a long time in the bladder is prone to undergo ammoniacal decomposition (p. 550).

Absorption.—The mucous membrane of the bladder is capable of absorbing substances—potassium iodide, and other soluble salts—very slowly.

As the ureters enter near the base of the bladder, the last secreted urine is always lowest. If a person remain perfectly quiet, strata of urine are thus formed, and the urine may be voided so as to prove this (Edlefsen).

The **pressure** within the bladder, when in the supine position = 13–15 centimetres of water. Increase of the intra-abdominal pressure (by inspiration, forced expiration, coughing, bearing-down) increases the pressure within the bladder. The erect posture also increases it, owing to the pressure of the viscera from above (Schatz, Dubois).

During micturition, the amount of urine voided at first is small, but it increases with the time, and towards the end of the act it again diminishes. In men, the last drops of urine are ejected from the urethra by voluntary contractions of the bulbo-cavernosus muscle. Adult dogs increase the stream rhythmically by the action of this muscle.

281. Retention and Incontinence of Urine.

Retention of urine or *ischuria* occurs:—1. When there is obstruction of the urethra, from foreign bodies, concretions, stricture, swelling of the prostate. 2. Paralysis or exhaustion of the musculature of the bladder; the latter sometimes occurs after delivery, in consequence of the pressure of the child against the bladder. 3. After section of the spinal cord (p. 590). 4. Where the voluntary impulses, are unable to act upon the inhibitory apparatus of the sphincter urethrae reflex, as well as when the sphincter urethrae reflex is increased.

Incontinence of urine (*stillicidium urinae*) occurs in consequence of—1. Paralysis of the sphincter urethrae. 2. Loss of sensibility of the urethra, which of course abolishes the reflex of the sphincter. 3. Trickling of the urine is a secondary consequence of section of the spinal cord, or of its degeneration.

Strangury is an excessive reflex contraction of the walls of the bladder and sphincter, due to stimulation of the bladder and urethra; it is observed in inflammation, neuralgia, [and after the use of some poisons, *e.g.*, cantharides].

Enuresis nocturna, or involuntary emptying of the bladder at night, may be due to an increased reflex excitability of the wall of the bladder, or weakness of the sphincter.

282. Comparative and Historical.

Amongst vertebrates, the urinary and genital organs are frequently combined, except in the osseous fishes. The Wolffian bodies which act as organs of excretion during the embryonic period, remain throughout life in fishes and amphibians, and continue to act as such (Gegenbaur). **Fishes.**—The *myxinoids* (cyclostomata) have the simplest kidneys; on each side is a long ureter with a series of short-stalked glomeruli with capsules, arranged along it. Both ureters open at the genital pore. In the other fishes, the kidneys lie often as elongated compact masses along both sides of the vertebral column. The two ureters unite to form a urethra, which always opens behind the anus, either united with the opening of the genital organs, or behind this. In the sturgeon and hag-fish, the anus and orifice of the urethra together form a cloaca. Bladder-like formations, which, however, are morphologically homologous with the urinary bladder of mammals, occur in fishes, either on each ureter (ray, hag-fish), or where both join.

In amphibians, the vasa efferentia of the testicles are united with the urinary tubules; the duct in the frog unites with the one on the other side, and both conjoined open into the cloaca, whilst the capacious *urinary bladder* opens through the anterior wall of the cloaca.

From reptiles upwards, the kidney is no longer a persistent Wolffian body, but a new organ. In reptiles, it is usually flattened and elongated; the ureters open singly into the cloaca. Saurians and tortoises have a urinary bladder. In birds, the isolated ureters open into the urogenital sinus, which opens into the cloaca, internal to the excretory ducts of the genital apparatus. The urinary bladder is always absent. In mammals, the kidneys often consist of many lobules, *e.g.*, dolphin, ox.

Amongst **invertebrates**, the **mollusca** have excretory organs in the form of canals, which are provided with an outer and an inner opening. In the mussel, this canal is provided with a spongy-like organ, often with a central cavity, and consisting of ciliated secretory cells, placed at the base of the gills (organ of Bojanus). In gasteropods, with analogous organs, uric acid has been found.

Insects, **spiders**, and **centipedes** have the so-called Malpighian vessels, which are partly excretory organs for uric acid and partly for bile. These vessels are long tubes, which open into the first part of the large intestine. In crabs, blind tubes connected with the intestinal tube, perhaps, have the same functions. The *vermes* also have renal organs.

Historical.—Aristotle directed attention to the relatively large size of the human bladder—he named the ureters. Massa (1552) found lymphatics in the kidney. Eustachius (†1580) ligatured the ureters and found the bladder empty. Cusanus (1565) investigated the colour and weight of the urine. Rousset (1581) described the muscular nature of the walls of the bladder. Vesling described the trigone (1753). The first important *chemical* investigations on the urine date from the time of van Helmont (1644). He isolated the solids of the urine and found among them common salt; he ascertained the higher specific gravity of fever-urine, and ascribed the origin of urinary calculi to the solids of the urine. Scheele (1766) discovered uric acid and calcium phosphate. Brand and Kunckel, phosphorus. Rouelle (1773) urea; and it got its name from Fourcroy and Vauquelin (1799). Berzelius found lactic acid; Seguin, albumin in pathological urine; Liebig, hippuric acid; Heintz and v. Pettenkofer, kreatin and kreatinin; Wollaston (1810) cystin. Marcet found xanthin; and Lindbergson, magnesia carbonate.

Functions of the Skin.

283. Structure of the Skin.

THE skin (2·3–2·7 mm. thick; specific gravity, 1057) consists of—

- [1. The *epidermis*;
2. The *chorium*, or *cutis vera*, with the papillæ;
3. The subcutaneous tissue, with masses of fat.]

The **epidermis** (0·08–0·12 mm. thick) consists of many layers of stratified epithelial cells united to each other by cement substance. The superficial layers—*stratum corneum* (Fig. 223, *b*)—consist of several layers of dry horny non-nucleated squames, which swell up in solution of caustic soda (Fig. 223, *E*). [It is always thickest where intermittent pressure is applied, as on the sole of the foot and palm of the hand.] The next layer is the *stratum lucidum* (Oehl)—it is clear and transparent in a section of skin, hence the name. It consists of compact layers of clear cells with vestiges of nuclei (between *b* and *d*). Under this is

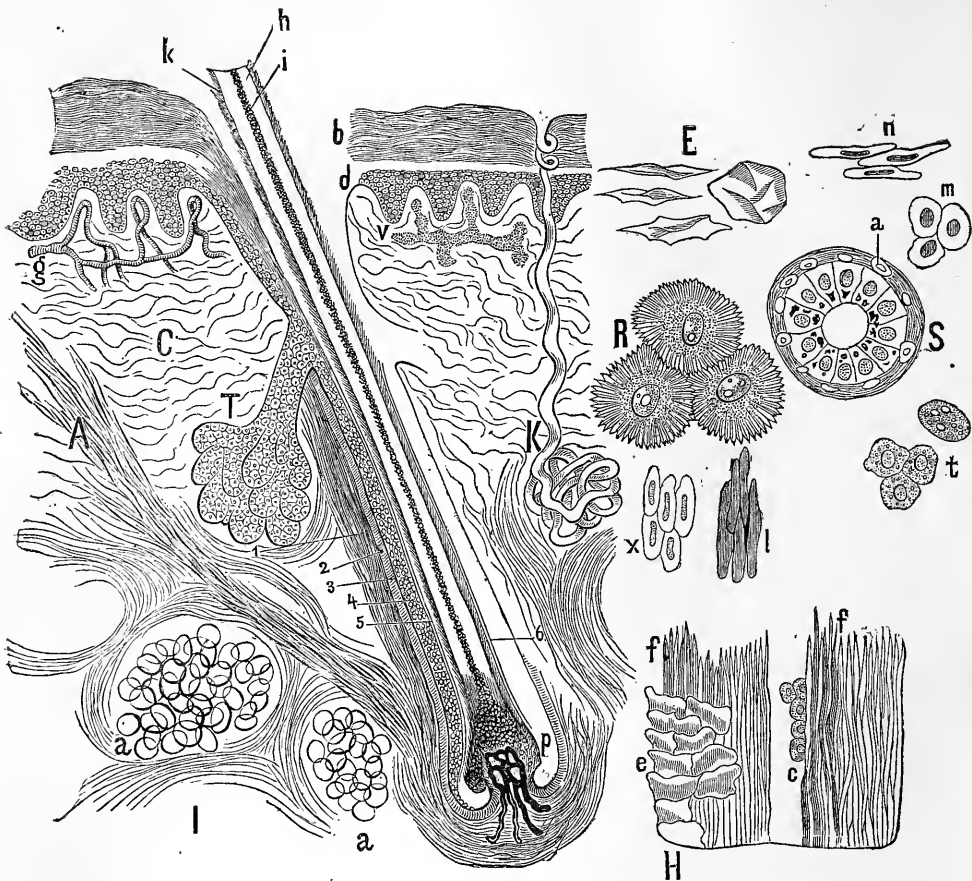

Fig. 223.

I, Vertical section of the skin, with a hair and sebaceous gland, T. Epidermis and chorium shortened—1, outer; 2, inner fibrous layer of the hair-follicle; 3, hyaline layer of the hair-follicle; 4, outer root sheath; 5, Huxley's layer of the inner root sheath; 6, Henle's layer of the same; *p*, root of the hair, with its papilla; A, arrector pili muscle; C, chorium; *a*, subcutaneous fatty tissue; *b*, epidermis (horny layer); *d*, rete Malpighii; *g*, blood-vessels of papillae; *v*, lymphatics of the same; *h*, horny or corneous substance; *i*, medulla or pith; *k*, epidermis or cuticle of hair; K, coil of sweat-gland; E, epidermal scales (seen from above and *en face*) from the stratum corneum; R, prickle cells from the rete Malpighii; *n*, superficial, and *m*, deep cells from the nail; H, hair magnified; *e*, cuticle; *c*, medulla, with cells; *f, f*, fusiform fibrous cells of the substance of the hair; *x*, cells of Huxley's layer; *l*, those of Henle's layer; S, transverse section of a sweat-gland from the axilla; *a*, smooth muscular fibres surrounding it; *t*, cells from a sebaceous gland, some of them containing granules of oil.

the rete mucosum or rete Malpighii, *d*, consisting of many layers of nucleated protoplasmic epithelial cells. These cells contain pigment in

the dark races, and in the skin of the scrotum, and around the anus. [The superficial cells are more fusiform, and contain granules which stain deeply with carmine. They constitute, 3, the *stratum granulosum* (Langerhans). In these cells the formation of keratin is about to begin, and the granules have been called *cleidin granules* by Ranvier. They are chemically on the way to be transformed into keratin. All corneous structures contain similar granules in the area where the cells are becoming corneous. Then follow several layers of more or less polyhedral cells, softer and more plastic in their nature, and exhibiting the characters of so-called "prickle cells" (Fig. 223, R).

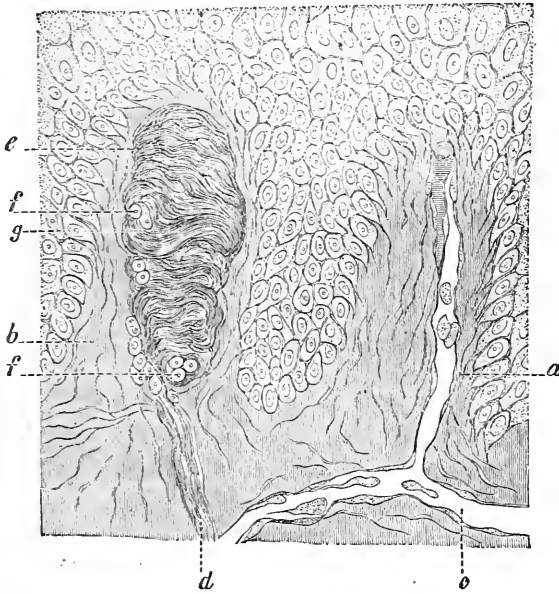

Fig. 224.

Vertical section of the cutis vera, and part of the epidermis—*g*, cells of the rete Malpighii *a*, capillary; *b*, papilla; *c*, blood-vessel; *d*, nerve-fibre entering a Wagner's touch-corpuscle, *e*; *f*, section of a nerve-fibre (after Biesiadecki).

The deepest layer of cells is more or less columnar, and the cells are placed vertically upon the papillæ (Fig. 224, *g*). Granular leucocytes or wandering cells are sometimes found between these cells (Biesiadecki). This layer has been called, 4, *Stratum Malpighii*. The rete Malpighii dips down between adjacent papillæ, and forms interpapillary processes. According to Klein, a delicate basement membrane separates the epidermis from the true skin.] The superficial layers of the epidermis are continually being thrown off, while new cells are continually being

formed in the deeper layers of the skin by proliferation of the cells of the rete Malpighii. There is a gradual change in the microscopic and chemical characters of the cells as we pass from the deepest to the most superficial layers of the epidermis.

- [I. Epidermis, $\left. \begin{array}{l} (1.) \textit{Stratum\ corneum.} \\ (2.) \textit{Stratum\ lucidum.} \\ (3.) \textit{Stratum\ granulosum,} \\ (4.) \textit{Stratum\ Malpighii,} \end{array} \right\}$ Rete Mucosum.

II. Cutis vera with its papillæ.

III. Subcutaneous layer with a layer of fat.]

[In a vertical section of the skin stained with picro-carmin, the *S. granulosum* is deeply stained red, and is thus readily distinguished amongst the other layers of the epidermis.]

The chorium (Fig. 223, I, C) is beset throughout its entire surface by numerous (0.5–0.1 mm. high) *papillæ* (Fig. 225), the largest being upon the volar surface of the hand and foot, on the nipple and glans penis. Most of the papillæ contain a looped capillary (*g*), while in limited areas some of them contain a touch-corpuscle (Fig. 224, *e*). The papillæ are disposed in groups, whose arrangement varies in different parts of the body. In the palm of the hand and sole of the foot they occur in rows, which are marked out by the existence of delicate furrows on the surface visible to the naked eye. The chorium consists of a dense net-work of bundles of white fibrous tissue mixed with a net-work of *elastic fibres*, which are more delicate in the papillæ. The connective-tissue contains many connective-tissue corpuscles and numerous leucocytes. The deeper connective-tissue layers of the chorium gradually pass into the *subcutaneous tissue*, where they form a trabecular arrangement of bundles,

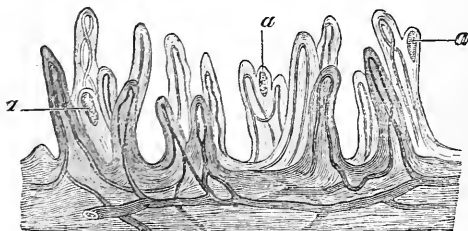

Fig. 225.

Papillæ of the skin, epidermis removed, blood-vessels injected; some contain a Wagner's touch-corpuscle, *a*, the others a capillary loop \times 60.

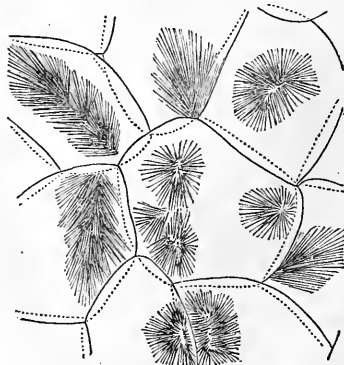

Fig. 226.

Fat cells containing crystals of margaric acid.

leaving between them elongated rhomboidal spaces filled for the most part with groups of *fat cells* (Fig. 223, *a, a*). [In microscopic sections, after the action of alcohol, the fat cells not unfrequently contain crystals of margaric acid (Fig. 226).] The long axis of the rhomb corresponds to the greater tension of the skin at that part (C. Langer). In some situations the subcutaneous tissue is devoid of fat [penis, eyelids.] In many situations, the skin is fixed by solid fibrous bands to subjacent structures, as fasciæ, ligaments, or bones (*tenacula cutis*); in other situations, as over bony prominences, *bursæ*, filled with synovial fluid, occur.

Smooth muscular fibres occur in the chorium in certain situations, on extensor surfaces (Neumann), nipple, areola mammæ, prepuce, perinæum, and in special abundance in the tunica dartos of the scrotum.

284. Nails and Hair.

The **nails** (specific gravity 1.19) consist of numerous layers of solid, horny, homogeneous, epidermal, or nail-cells, which may be isolated with a solution of caustic alkalies, when they swell up and exhibit the remains of an elongated nucleus (Fig. 223, *n, m*). The whole under surface of the nail rests upon the *nail-bed*;

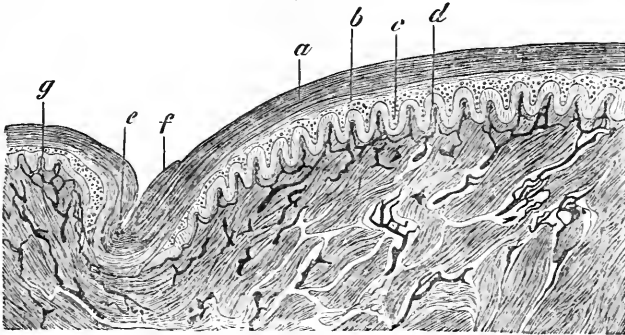

Fig. 227.

Transverse section of one-half of a nail—*a*, nail-substance; *b*, more open layer of cells of the nail-bed; *c*, stratum Malpighii of the nail-bed; *d*, transversely divided papillæ; *e*, nail-groove; *f*, horny layer of *e* projecting over the nail; *g*, papillæ of the skin on the back of the finger.

the lateral and posterior edges lie in a deep groove, the *nail-groove* (Fig. 227, *e*). The chorium under the nail is covered throughout its entire extent by longitudinal rows of papillæ (Fig. 227, *d*). Above this, there lies, as in the skin, many layers of prickle cells like those in the rete Malpighii (Fig. 223, *c*), and above this again is the substance of the nail (Fig. 227, *a*). [The Stratum granulosum is rudimentary in the nail-bed. The substance of the nail represents the stratum lucidum, there being no stratum corneum (Klein)]. The posterior part of the nail-groove and the half-moon, brighter part or *lunule*, form the *root* of the nail. They are, at the same time, the *matrix*, from which growth of the nail takes place. The lunule is present in an isolated nail, and is due to diminished transparency of the posterior part of

the nail, owing to the special thickness and uniform distribution of the cells of the rete Malpighii (Toldt).

Growth of the Nail.—According to Unna, the matrix extends to the front part of the lunule. The nail grows continually from behind forwards, and is formed by layers secreted or formed by the matrix. These layers run parallel to the surface of the matrix. They run obliquely from above and behind, downwards and forwards, through the thickness of the substance of the nail. The nail is of the same thickness from the anterior margin of the lunule forwards to its free margin. Thus the nail does not grow in thickness in this region.

In the course of a year the fingers produce about 2 grammes of nail-substance, and relatively more in summer than in winter (Moleschott, Benecke).

Development.—Unna makes the following statements regarding the development of the nails:—1. From the second to the eighth month of fetal life, the position of the nail is indicated by a partial but marked horny condition of the epidermis on the back of the first phalanx, the “*eponychium*.” The remainder of this substance is represented

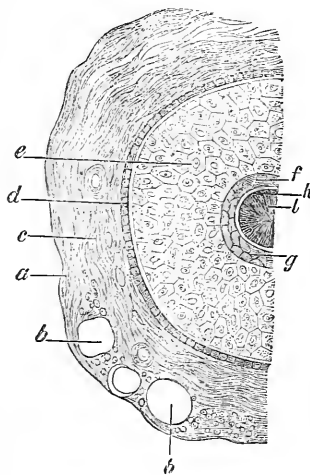

Fig. 228.

Transverse section of a hair below the level of the neck of a hair-follicle—*a*, outer fibrous coat with *b*, sections of blood-vessels; *c*, inner circularly disposed layer; *d*, glass-like layer; *e*, outer; *f*, *g*, inner root-sheath; *f*, outer layer of the same (Henle's sheath); *g*, inner layer of the same (Huxley's sheath); *h*, cuticle; *l*, hair.

(? smooth muscular fibres) arranged circularly. [It does not extend throughout the whole length of the follicle.] 3. Inside this layer is a transparent, hyaline, glass-like basement membrane (Fig. 223, 3, and Fig. 228), which ends at the neck of the hair-follicle; while above it is continued, as the basement membrane which exists between the epidermis and chorium. In addition to these coverings, a hair-follicle

layer, which separates the future nail from the surface of the furrow. 2. The future nail is formed under the eponychium, with its first nail-cells still in front of the nail-groove; then the nail grows and pushes forward towards the groove. At the seventh month, the nail (itself covered by the eponychium) covers the whole extent of the nail-bed. 3. When, at a later period, the eponychium splits off, the nail is uncovered. After birth, the papillæ are formed on the bed of the nail, while simultaneously, the matrix passes backwards to the most posterior part of the groove.

The whole of the skin, with the exception of the palmar surface of the hand, sole of the foot, dorsal surface of the third phalanx of the fingers and toes, outer surface of the eyelids, glans penis, inner surface of the prepuce, and part of the labia is covered with hairs, which may be strong or fine (lanugo).

The Hair.—(Specific gravity 1.26) is fixed by its lower extremity (root) in a depression of the skin or a *hair-follicle* (Fig. 223, I, *p*) which passes obliquely through the thickness of the skin, sometimes as far as the subcutaneous tissue. The structure of a hair-follicle is the following:—1. The *outer fibrous layer* (Fig. 223, 1, and Fig. 228), composed of interwoven bundles of connective-tissue arranged for the most part longitudinally, and provided with numerous blood-vessels and nerves. [It is just the connective-tissue of the surrounding chorium.] 2. The *inner fibrous layer* (Fig. 223, 2, and Fig. 228) consists of a layer of fusiform cells

has epithelial coverings which must be regarded in relation to the layers of the epidermis. Immediately within the glass-like membrane is the *outer root-sheath* (Fig. 223, 4, and Figs. 228 and 229), which consists of so many layers of epithelial cells that it forms a conspicuous covering. It is, in fact, a direct continuation of the Stratum Malpighii, and consists of many layers of soft cells, the cells of the outer layer being cylindrical. Towards the base of the hair-follicle it becomes narrower, and is united to, and continuous with, the cells of the root of the hair itself, at least in fully-developed hairs. The horny layer of the epidermis continues to retain its properties as far down as the orifice of the sebaceous follicle. Below this point, however, it is continued as the *inner root-sheath*. This consists of (1) a single layer of elongated, flat, homogeneous, non-nucleated cells (Fig. 223, 6, and Fig. 228, *f*—*Henle's layer*) placed next and within the outer root-sheath. Within this lies (2) *Huxley's layer* (Fig. 223, 5, and Fig. 228, *g*) consisting of nucleated elongated polygonal cells (Fig. 223, *x*, and 3), while the *cuticle* of the hair-follicle is composed of cells analogous to those of the surface of the hair itself. Towards the bulb of the hair these three layers become fused together.

[Coverings of a hair-follicle arranged from without inwards—

1. Fibrous layers, $\left\{ \begin{array}{l} (a) \text{ Longitudinally arranged fibrous tissue.} \\ (b) \text{ Circularly arranged spindle cells.} \end{array} \right.$
2. Glass-like (hyaline) membrane.
3. Epithelial layers, $\left\{ \begin{array}{l} (a) \text{ Outer root-sheath.} \\ (b) \text{ Inner root-sheath.} \\ (c) \text{ Cuticle of the hair.} \end{array} \right. \left\{ \begin{array}{l} \text{Henle's layer.} \\ \text{Huxley's layer.} \end{array} \right.$
4. The hair itself.]

The **arrector pili muscle** (Fig. 223, A) is a fan-like arrangement of a layer of smooth muscular fibres, which is attached below to the side of a hair-follicle and extends towards the surface of the chorium; as it stretches obliquely upwards, it subtends the obtuse angle formed by the hair-follicle and the surface of the skin [or, in other words, it forms an acute angle with the hair-follicle, and between it and the follicle lies the sebaceous gland]. When these muscles contract, they raise and erect the hair-follicles, producing the condition of *cutis anserina* or *goose-skin*. As the sebaceous gland lies in the angle between the muscle and the hair-follicle, contraction of the muscle compresses the gland and favours the evacuation of the sebaceous secretion. It also compresses the blood-vessels of the papilla (Unna).

The **hair** with its enlarged bulbous extremity—*hair-bulb*—sits upon, or rather it embraces the papilla. It consists of—(1) the *marrow* or *medulla* (Fig. 223, *i*) which is absent in woolly hair and in the hairs formed during the first years of life. It consists of two or three rows of cubical cells (H, *c*). (2) Outside this lies the thicker *cortex* (*h*) which consists of elongated, rigid, horny, fibrous cells (H, *f, f*), while in and between these cells lie the pigment granules of the hair. (3) The surface of the hair is covered with a *cuticle* (*k*), consisting of imbricated layers of non-nucleated squames.

Grey Hair.—When the hair becomes *grey*, as in old age, this is due to a defective formation of pigment in the cortical part. The silvery appearance of white hair is increased when small air-cavities are developed, especially in the medulla and to a less extent in the cortex, where they reflect the light. Landois records a case of the hair becoming *suddenly grey*, in a man whose hair became *grey* during a single night, in the course of an attack of delirium tremens. Numerous air-spaces were found throughout the entire marrow of the (blond) hairs, while the hair-pigment still remained.

Development of Hair.—According to Kölliker, from the 12th-13th week of intra-uterine life, solid finger-like processes of the epidermis are pushed down into the chorium. The process becomes flasked-shaped, while the central cells of

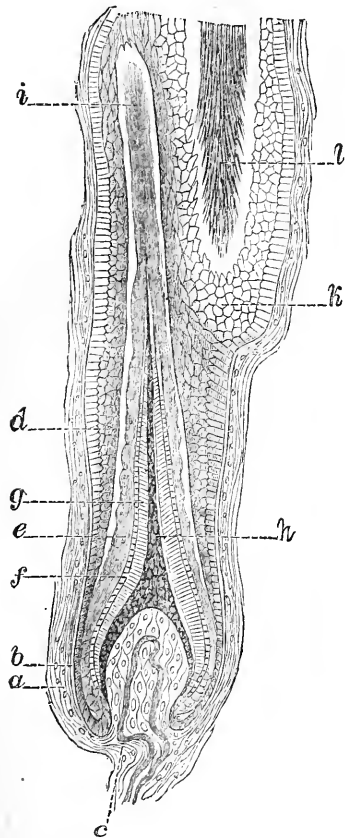

Fig. 229.

Section of a hair-follicle while a hair is being shed (v. Ebner)—*a*, outer and middle sheaths of hair-follicle; *b*, hyaline membrane; *c*, hair papilla, with loop of capillary; *d*, outer, *e*, inner root-sheath; *f*, cuticle of the latter; *g*, cuticle of the hair; *h*, young non-medullated hair; *i*, tip of new hair; *l*, hair-knob of the shed hair, with *k*, the remainder of the cast-off outer root-sheath.

end becomes split up like a brush. becomes smaller, while on the old papilla, a new formation of a hair begins, the

the cylinder become elongated and form a conical body, arising as it were, from the depth of the recess. It becomes differentiated into an inner darker part, which becomes the hair, and into a thinner, clearer, layer covering the former, the inner root-sheath. The outer cells, *i.e.*, those lying next the wall of the sac, form the outer root-sheath. Outside this again, the fibrous tissue of the chorium forms a rudimentary hair-follicle, while one of the papillæ grows up against it, indents it, and becomes embraced by the bulb of the hair. This is the hair papilla which contains a loop of blood-vessels. The cells of the bulb of the hair proliferate rapidly and thus the hair grows in length. Thus the point of the hair is gradually pushed upwards, pierces the inner root-sheath and passes obliquely through the epidermis. The hairs appear upon the forehead at the 19th week; at the 23rd to 25th week, the lanugo hairs appear free, and they have a characteristic arrangement on different parts of the body.

Physical Properties.—Hair has very considerable elasticity (stretching to 0.33 of its length), considerable cohesion (carrying 3-5 lbs.), resists putrefaction for a long time, and is highly hygroscopic. The last property is also possessed by epidermal scales, as is proved by the pains that occur in old wounds and scars during damp weather.

Growth of a hair occurs by proliferation of the cells on the surface of the hair papilla, these cells representing the matrix of the hair. Layer after layer is formed, and gradually the hair is raised higher within its follicle.

Change of the Hair.—The results are by no means uniform. According to one view, when the hair has reached its full length, the process of formation on the surface of the hair papilla is interrupted; the root of the hair is raised from the papilla, becomes horny, remains almost devoid of pigment, and is gradually more and more lifted upwards from the surface of the papilla, while its lower bulbous The lower empty part of the hair-follicle

old hair, at the same time falling out (Kölliker, C. Langer). According to Stieda, the old papilla disappears, while a new one is formed in the hair-follicle, and from it the new hair is developed.

According to Götte, in addition to the hair which grows on the papilla, other hairs developed from the outer root-sheath, are formed in the *same* hair-follicle. Unna again describes the growth and change of the hair differently. He believes that each hair grows for a time from the surface of the papilla. It then frees itself, and with its brush-like lower end or bulb is *transplanted* anew on the outer root-sheath, about the middle of the hair-follicle. The free papilla can thus produce a new hair, which may even grow along side the former, until the former falls out. New recesses with new papillæ are formed latterly in the hair-follicle, and from them new hairs arise.

285. The Glands of the Skin.

The **sebaceous glands** (Fig 223, I, T), are simple acinous glands which open by a duct into the hair-follicles of large hairs near their upper part; in the case of small hairs, they may project from the duct of the gland (Fig. 230). In some situations, the ducts of the glands open free upon the surface—*e.g.*, the glands of labia minora, glans, prepuce (Tyson's glands), and the red margins of the lips. The largest glands occur in the nose and in the labia; they are absent only from the vola manus and planta pedis.

The oblong alveoli of the gland consist of a basement membrane lined with small polyhedral nucleated granular secretory cells (Fig. 223, *t*). Within this are other polyhedral cells, whose substance contains numerous oil-globules; the cells become more fatty as we proceed towards the centre of the alveolus. The cells lining the duct are continuous with those of the outer root-sheath. The detritus formed by the fatty metamorphosis of the cells constitutes the *sebum* or sebaceous secretion.

[As is shown in Fig. 230, the sebaceous glands are very large in the fetus, while the lanugo or fetal hair is relatively very small].

The **sweat-glands** (Fig. 223, I, *k*), sometimes called *sudoriparous* glands, consist of a long blind tube, whose lower end is arranged in the form of a coil placed in the areolar tissue under the skin, while the somewhat smaller upper end or excretory portion, winds in a vertical, slightly wave-like manner, through the chorium, and in a cork-screw or spiral manner through the epidermis, where it opens with a free, somewhat trumpet-shaped, mouth. The glands are both very numerous and

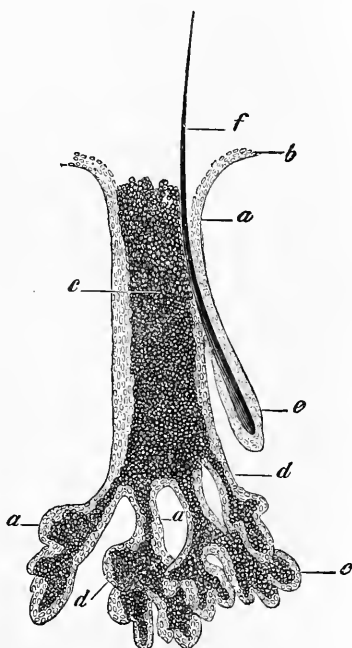

Fig. 230.

Sebaceous gland, with a long lanugo hair—*a*, granular epithelium; *b*, rete Malpighii continuous with *a*; *c*, fatty cells and free fat, the contents of the gland; *d*, acini; *e*, hair-follicle, with a small hair, *f*.

large in the palm of the hand, sole of the foot, axilla, forehead, and around the nipple; few on the back of the trunk, and are absent on the glans, prepuce, and margin of the lips. The *circumanal* glands and the *ceruminous glands* of the external auditory meatus, and Moll's glands, which open into the hair-follicles of the eyelashes, are modifications of the sweat-glands.

Each gland-tube consists of a basement membrane lined by cells; the excretory part or *sweat-canal* of the tube is lined by several layers of cubical cells, whose surface is covered by a delicate cuticular layer, a small central lumen being left. Within the coil the structure is different. The first part of the coil resembles the above, but as the coil is the true secretory part of the gland, its structure differs from the sweat-canal. This, the so-called *distal* portion of the tube, is lined by a *single* layer of clear nucleated cylindrical epithelium (Fig. 223, S), often containing oil-globules (Ranvier). Smooth muscular fibres (Kölliker) are arranged longitudinally along the tube in the large glands (Fig. 223, S, a.) There is a distinct lumen present in the tube. As the duct passes through the epidermis, it winds its way between the epidermal cells without any independent membrane lining it (Heynold). A net-work of *capillaries* surrounds the coil. Before the arteries split up into capillaries, they form a true rete mirabile around the coil (Brücke). This is comparable to the glomerulus of the kidney, which may also be regarded as a rete mirabile (p. 522). Numerous *nerves* pass to form a plexus, and terminate in the glands (Tomsa).

The **total number** of sweat-glands is estimated by Krause at $2\frac{1}{2}$ millions, which gives a secretory surface of nearly 1,080 square metres. *These glands secrete sweat.* Nevertheless, an oily or fatty substance is often mixed with the sweat. In some animals (glands in the sole of the foot of the dog, and in birds), this oily secretion is very marked.

Lymphatics.—Numerous lymphatics occur in the cutis, some arise by a blind end, and others form loops within the papilla on a plane lower than the vascular capillary. [These open into more or less horizontal net-works of tubular lymphatics in the cutis, and these again into the wide lymphatics of the subcutaneous tissue, which are well provided with valves.] Special lymphatic spaces are disposed in relation with the hair-follicles and their glands (Neumann), [and also with the fat (Klein). The lymphatics of the skin are readily injected with Berlin blue by the puncture method.]

The **blood-vessels** of the skin are arranged in several systems. There is a superficial system from which proceed the capillaries for the papillæ. There is a deeper system of vessels which supplies special blood-vessels to (a) the fatty tissue; (b) the hair-follicles, each of which has a special vascular arrangement of its own, and in connection with this, each sebaceous gland receives a special artery; (c) an artery goes also to each coil of a sweat-gland, where it forms a dense plexus of capillaries (Tomsa).

286. The Skin as a Protective Covering.

The *subcutaneous fatty tissue* fills up the depressions between adjoining parts of the body, and covers projecting parts, so that a more rounded appearance of the body is thereby obtained. It also acts as a soft elastic pad, and protects delicate parts from external pressure (sole of the foot, palm of the hand), and it often surrounds and protects blood-vessels, nerves, &c. It is a bad conductor of heat, and thus acts as one of the factors regulating the radiation of heat (§ 214, II., 4), and, therefore, the temperature of the body. The epidermis and cutis vera

also act in the same manner (§ 212). Klug found that, the heat conduction is less through the skin and subcutaneous fatty tissue than through the skin alone; the epidermis conducts heat less easily than the fat and the chorium.

The solid, elastic, easily movable cutis affords a good *protection against external, mechanical injuries*; while the dry, impermeable, horny, epidermis, devoid of nerves and blood-vessels, affords a further protection against the absorption of poisons, and at the same time, it is capable of resisting to a certain degree, thermal and even chemical actions. A thin layer of fatty matter protects the free surface of the epidermis from the macerating action of fluids, and from the disintegrating action of the air. The epidermis is important in connection with the *fluids of the body*. It exerts a certain pressure upon the cutaneous capillaries, and, to a limited extent, prevents too great diffusion of fluid from the cutaneous vessels. Parts of the skin robbed of their epidermis are red and are always moist. When dry, the epidermis and the epidermal appendages are bad conductors of electricity (§ 326). Lastly, we may say that the existence of uninjured epidermis prevents adjoining parts from growing together.

287. Cutaneous Respiration and Secretion— Sebum—Sweat.

The skin with a surface of more than $1\frac{1}{2}$ square metres has the following *secretory* functions:—

1. The *respiratory excretion*;
2. The *secretion of sebaceous matter*; and
3. The *secretion of sweat*.

1. **Respiration by the Skin** has been referred to already (§ 131). The organs therein concerned are the tubes of the sweat-glands, moistened as they are with fluids, and surrounded by a rich net-work of capillaries. It is uncertain whether or not the skin gives off a small amount of N or ammonia (compare p. 264). Röhrig made experiments upon an arm placed in an air-tight metal box. According to him, the amount of CO_2 and H_2O excreted is subject to certain daily variations; it is increased by digestion, increased temperature of the surroundings, the application of cutaneous stimuli, and by impeding the pulmonary respiration. The exchange of gases also depends upon the vascularity of certain parts of the skin, while the cutaneous absorption of O also depends upon the number of coloured corpuscles in the blood.

In *frogs* and other amphibians, with a thin, always moist epidermis, the

cutaneous respiration is more considerable than in warm-blooded animals. In winter frogs, the skin alone yields $\frac{2}{3}$ of the total amount of CO_2 excreted; in summer frogs, $\frac{2}{3}$ of the same (Bidder); thus, in these animals it is a more important respiratory organ than the lungs themselves. *Suppression of the cutaneous activity*—e.g., by varnishing or dipping the skin in oil—causes death by asphyxia sooner than ligature of the lungs.

Varnishing the Skin.—When the skin of a warm-blooded animal is covered with an impermeable varnish [such as gelatin] (Fourcault, Becquerel, Breschet), death occurs after a time, probably owing to the loss of too much heat. The formation of crystalline ammonio-magnesian phosphate in the cutaneous tissues of such animals (Edenhuizen), is not sufficient to account for death, nor are congestion of internal organs and serous effusions satisfactory explanations. The retention of the volatile substances (acids) present in the sweat is not sufficient. Strong animals live longer than feeble ones; horses die after several days (Gerlach); they shiver and lose flesh. The larger the cutaneous surface left unvarnished, the later does death take place. Rabbits die when $\frac{1}{3}$ of their surface is varnished.

When the entire surface of the animal is varnished, the temperature rapidly falls (to 19°), the pulse and respirations vary; usually they fall when the varnishing process is limited; increased frequency of respiration has been observed (§ 225).

[In extensive burns of the skin, not only is there disintegration of the coloured blood-corpuscles (v. Lesser), but in some cases ulcers occur in the duodenum, but the cause of the ulceration has not been ascertained satisfactorily (Curling).]

2. Sebaceous Secretion.—The fatty matter as it is excreted from the acini of the sebaceous glands is fluid, but even within the excretory duct of the gland, it stagnates and forms a white fat-like mass, which may sometimes be expressed (at the side of the nose) as a worm-like white body, the so-called comedo. The sebaceous matter keeps the skin supple, and prevents the hair from becoming too dry. *Microscopically*, the secretion is seen to contain innumerable fatty granules, a few gland-cells filled with fat, visible after the addition of caustic soda, crystals of cholesterin, and in some men, a microscopic mite-like animal (*Demodex folliculorum*).

Chemical Composition.—The constituents are for the most part *fatty*; chiefly *olein* (fluid) and *palmitin* (solid) fat, soaps and some cholesterin; a small amount of albumin and unknown extractives. Amongst the inorganic constituents, the insoluble earthy phosphates are most abundant; while the alkaline chlorides and phosphates are less abundant.

The **varnix caseosa**, which covers the skin of a new-born child, is a greasy mixture of sebaceous matter and macerated epidermal cells (containing 47.5 p.c. fat). A similar product is the *smegma præputialis* (52.8 p.c. fat) in which an ammonia soap is present.

The **cerumen** or ear-wax is a mixture of the secretions of the ceruminous glands of the ear (similar in structure to the sweat-glands) and the sebaceous glands of the auditory canal. Besides the constituents of sebum, it contains yellow or brownish particles, a bitter yellow extractive substance derived from the ceruminous glands, potash soaps and a special fat (Berzelius). The secretion of the *Meibomian glands* is sebum.

3. The Sweat.—The sweat is secreted in the coil of the sweat-glands. The nuclei of the secretory cells become more globular during the process (Bubnoff), while the cells themselves (horse) become granular

(Renaut). As long as the secretion is small in amount, the water secreted is evaporated at once from the skin along with the volatile constituents of the sweat; as soon however as the secretion is increased, or evaporation is prevented, drops of sweat appear on the surface of the skin. The former is called *insensible perspiration*, and the latter *sensible perspiration*. The amount of water given off by the skin diminishes from morning to mid-day, and increases again towards evening. The skin of the arm secretes more than that of the leg (Janssen). [Broadly, the quantity is about 2 lbs. in 24 hours.]

Method.—Sweat is obtained from a man by placing him in a metallic vessel in a warm bath; the sweat is rapidly secreted and collected in the vessel. In this way Favre collected 2,560 grammes of sweat in 1½ hours. An arm may be inclosed in a cylindrical vessel, which is fixed air-tight round the arm with an elastic bandage (Schottin).

Amongst *animals*, the horse sweats, so does the ox, but to a less extent; the vola and planta of apes, cats, and the hedgehog secrete sweat; the snout of the pig sweats (?), while the goat, rabbit, rat, mouse, and dog are said not to sweat (Luchsinger). [The skin over the body and the pad on the dog's foot contain numerous sweat-glands, which open free on the surface of the pad and into the hair-follicles on the general surface of the skin (W. Stirling).]

Microscopically.—The sweat contains only a few epidermal scales accidentally mixed with it, and fine fatty granules from the sebaceous glands.

Chemical Composition.—Its reaction is *alkaline*, although it frequently is acid, owing to the admixture of fatty acids from decomposed sebum. During profuse secretion it becomes neutral, and lastly alkaline again (Trümper and Luchsinger). The sweat is colourless, slightly turbid, of a saltish *taste*, and has a characteristic odour varying in different parts of the body; the *odour* is due to the presence of volatile fatty acids.

The constituents are—*water*, which is increased by copious draughts of that fluid. The *solids* amount to 1·180 per cent. (0·70–2·66 per cent. —Funke), and of these 0·96 per cent. is organic and 0·33 inorganic. Amongst the *organic* constituents, are *neutral fats* (palmitin, stearin), also present in the sweat of the palm of the hand, which contains no sebaceous glands (Krause), *cholesterin*, *volatile fatty acids* (chiefly formic, acetic, butyric, propionic, caproic, capric acids), varying qualitatively and quantitatively in different parts of the body. These acids are most abundant in the sweat first (acid) secreted. There are also traces of *albumin* (similar to casein), and *urea* (Funke, Picard), about 0·1 per cent. In uræmic conditions (anuria in cholera), urea has been found crystallised on the skin (Schottin, Drasche). When the secretion of sweat is greatly increased, the amount of urea in the urine is diminished both in health and in uræmia (Leube). The nature of the

reddish yellow pigment, which is extracted from the residue of sweat by alcohol, and coloured green by oxalic acid, is unknown. Amongst *inorganic* constituents, those that are easily soluble are more abundant than those that are soluble with difficulty, in the proportion of 17 to 1 (Schottin); sodium chloride, 0.2; potassium chloride, 0.02; sulphates, 0.01 per 1000, together with traces of earthy phosphates and sodium phosphate. Sweat contains CO_2 in a state of absorption and some N. When decomposed with free access of air, it yields ammonia salts (Gorup-Besanez).

Excretion of Substances.—Some substances when introduced into the body reappear in the sweat—benzoic, cinnamic, tartaric, and succinic acids are readily excreted; quinine and potassium iodide with more difficulty. Mercuric chloride, arsenious and arsenic acids, sodium and potassium arseniate have also been found. After taking arseniate of iron, arsenious acid has been found in the sweat, and iron in the urine. Mercury iodide reappears as a chloride in the sweat, while the iodine occurs in the saliva.

288. Conditions Influencing the Secretion of Sweat.

Influence of Nerves.

The secretion of the skin, which averages about $\frac{1}{67}$ of the body-weight—*i.e.*, about double the amount of water excreted by the lungs—may be increased or diminished. The liability to perspire varies much in different individuals. The following conditions influence the secretion—

1. *Increased temperature* of the surroundings causes the skin to become red with profuse secretion of sweat (§ 214, II., 1). Cold, as well as a temperature of the skin about 50°C ., arrest the secretion.
2. A very *watery condition of the blood*—*e.g.*, after copious draughts of warm water—increases the secretion.
3. Increased *cardiac and vascular activity*, whereby the blood-pressure within the cutaneous capillaries is increased, has a similar effect; increased sweating follows increased *muscular activity*.
4. Certain *drugs (sudorifics)* favour sweating—*e.g.*, pilocarpin, Calabar bean, strychnin, picrotoxin, muscarin, nicotin, camphor, ammonia compounds—while others, as atropin and morphia, in large doses, diminish or paralyse the secretion.
5. It is important to notice the *antagonism* which exists, probably upon mechanical grounds, between the secretion of sweat, the urinary secretion, and the evacuation of the intestine. Thus, copious secretion of urine (*e.g.*, in diabetes), and watery stools coincide with dryness of the skin (Theophrastus). If the secretion of sweat be increased, the percentage of salts, urea (Funke), and albumin (Leube) is also increased, whilst the other organic substances are diminished. The more saturated the

air is with watery vapour, the sooner does the secretion appear in drops upon the skin, while in dry air or air in motion, owing to the rapid evaporation, the formation of drops of sweat is prevented, or at least retarded.

The influence of nerves upon the secretion of sweat is very marked.

I. As in the secretion of saliva (§ 145), vaso-motor nerves are usually in action at the same time as the proper *secretory nerves*; the vaso-dilator nerves (sweating with a *red congested* skin) are most frequently involved. The fact that secretion of sweat does occasionally take place when the skin is *pale* (fear, death-agony) shows that, when the vaso-motor nerves are excited, so as to constrict the cutaneous blood-vessels, the sweat-secretory nerve-fibres may also be active.

Under certain circumstances, the *amount of blood* in the skin seems to determine the occurrence of sweating; thus Dupuy found that, section of the cervical sympathetic caused secretion on that side of the neck of a horse; while Nitzelnadel found that, percutaneous electrical stimulation of the cervical sympathetic in man, limited the sweating.

II. Secretory nerves, altogether independent of the circulation, control the secretion of sweat. Stimulation of these nerves, even in a limb which has been amputated in a kitten, causes a temporary secretion of sweat—*i.e.*, after complete arrest of the circulation (Goltz, Kendall and Luchsinger, Ostroumow). In the intact condition of the body, however, profuse perspiration, at all events, is always associated with simultaneous dilatation of the blood-vessels (just as in stimulation of the facial nerve, an increased secretion of saliva is associated with an increased blood-stream—§ 145, A, I). The secretory nerves and those for the blood-vessels seem to lie in the same nerve-trunks.

The secretory nerves for the hind limbs (cat) lie in the sciatic nerve. Luchsinger found that, stimulation of the peripheral end of this nerve caused renewed secretion of sweat for a period of half-an-hour, provided the foot was always wiped to remove the sweat already formed. If a kitten, whose sciatic nerve is divided on one side, be placed in a chamber filled with heated air, all the three intact limbs soon begin to sweat, but the limb whose nerve is divided does not, nor does it do so when the veins of the limb are ligatured so as to produce congestion of its blood-vessels. [The cat sweats only on the hairless soles of the feet.] As to the *course* of the secretory fibres to the sciatic nerve, some pass directly from the spinal cord (Vulpian), some pass into the abdominal sympathetic (Luchsinger, Nawrocki, Ostroumow), through the rami communicantes and the anterior spinal roots from the upper lumbar and lower dorsal spinal cord (9th–13th dorsal vertebræ—cat) where the sweat-centre for the lower limbs is situated.

The sweat-centre may be excited *directly*.—(1) By a strongly venous

condition of the blood, as during dyspnœa—*e.g.*, in the secretion of sweat that sometimes precedes death; (2) by over-heated blood (45°C.) streaming through the centre; (3) by certain poisons (see p. 606). The centre may be also excited *reflexly*, although the results are variable—*e.g.*, stimulation of the crural and peroneal nerves, as well as the central end of the opposite sciatic nerve excites it (Luchsinger). [The pungency of mustard in the mouth may excite free perspiration on the face.]

Anterior Extremity.—The secretory fibres lie in the ulnar and median nerves, for the fore-limbs of the cat; most of them, or indeed all of them (Nawrocki) pass into the thoracic sympathetic (Ggl. stellatum), and part (?) runs in the nerve-roots direct from the spinal cord (Luchsinger, Vulpian, Ott). A similar sweat-centre for the upper limbs lies in the lower part of the cervical spinal cord. Stimulation of the central ends of the brachial plexus causes a reflex secretion of sweat upon the foot of the other side (Adamkiewicz). At the same time the hind feet also perspire.

Pathological.—Degeneration of the motor ganglia of the anterior horns of the spinal cord causes loss of the secretion of sweat, in addition to paralysis of the voluntary muscles of the trunk (Erb, Adamkiewicz, Strauss, Bloch).

The perspiration is increased in paralysed as well as in œdematous limbs. In nephritis, there are great variations in the amount of water given off by the skin.

Head.—The secretory fibres for this part (horse, man, snout of pig) lie in the thoracic sympathetic, pass into the ganglion stellatum, and ascend in the cervical sympathetic. Percutaneous electrical stimulation of the cervical sympathetic in man, causes sweating of that side of the face and of the arm (M. Meyer). In the cephalic portion of the sympathetic, some of the fibres pass into, or become applied to, the branches of the trigeminus, which explains why stimulation of the infraorbital nerve causes secretion of sweat. Some fibres, however, arise *directly* from the roots of the trigeminus (Luchsinger), and the facial (Vulpian, Adamkiewicz). Undoubtedly the cerebrum has a direct effect either upon the vaso-motor nerves (p. 607, I.) or upon the sweat-secretory fibres (II.), as in the sweating produced by psychical excitement (pain, fear, etc.).

Adamkiewicz and Senator found that, in a man suffering from abscess of the motor region of the cortex cerebri for the arm, there were spasms and perspiration in the arm.

Sweat-centre.—According to Adamkiewicz, the medulla oblongata contains the *dominating sweat-centre* (§ 373—Marmé, Nawrocki). When this centre is stimulated (Adamkiewicz) in a cat, all the four feet sweat, even three-quarters of an hour after death.

III. The nerve-fibres which terminate in the *smooth muscular fibres of the sweat-glands* act upon the excretion of the secretion.

[Changes in the Cells during Secretion.—In the resting glands of the horse, the cylindrical cells are clear with the nucleus near their attached ends, but after free perspiration they become granular, and their nucleus is more central (Renaut).]

If the sweat-nerves be divided (cat), injection of pilocarpin causes a secretion of sweat, even at the end of 3 days. After a longer period than 6 days, there may be no secretion at all. This observation coincides with the phenomenon of dryness of the skin in paralysed limbs. Dieffenbach found that, transplanted portions of skin first began to sweat when their sensibility was restored. If a motor nerve (tibial, median, facial) of a man be stimulated, sweat appears on the skin over the muscular area supplied by the nerve, and also upon the corresponding area of the opposite non-stimulated side of the body. This result occurs when the circulation is arrested, as well as when it is active. Sensory and thermal stimulation of the skin always cause a bilateral reflex secretion, independently of the circulation. The area of sweating is independent of the part of the skin stimulated (Adamkiewicz).

289. Pathological Variations.

1. **Anidrosis** or *diminution* of the secretion of sweat occurs in diabetes and the cancerous cachexia, and along with other disturbances of nutrition of the skin, in some nervous diseases—*e.g.*, in dementia paralytica; in some limited regions of the skin it has occurred in certain tropho-neuroses—*e.g.*, in unilateral atrophy of the face, and in paralysed parts. In many of these cases, it depends upon paralysis of the corresponding nerves (Eulenburg) or their *spinal sweat-centres* (pp. 607, 608).

2. **Hyperidrosis** or *increase* of the secretion of sweat occurs in easily excitable persons, in consequence of the irritation of the nerves concerned (§ 288)—*e.g.*, the sweating which occurs in debilitated conditions and in the hysterical (sometimes on the head and hands), and the so-called epileptoid sweats (Eulenburg). Sometimes the increase is confined to *one side of the head* (H. unilateralis). This condition is often accompanied with other nervous phenomena, partly with the symptoms of paralysis of the cervical sympathetic (redness of the face, narrow pupil), partly with symptoms of stimulation of the sympathetic (dilated pupil, exophthalmos). It may occur without these phenomena, and is due perhaps to stimulation of the proper secretory fibres alone.

3. **Paridrosis** or *qualitative changes* in the secretion of sweat, *e.g.*, the rare case of "*sweating of blood*" (*Hæmatohidrosis*—Th. Bartholinus, 1654), is sometimes unilateral. According to Hebra, in some cases this condition represents a vicarious form of menstruation. It is, however, usually one of many phenomena of nervous affections. Bloody sweat sometimes occurs in yellow fever. Bile-pigments have been found in the sweat in jaundice; blue sweat from indigo (Bizio), from pyocyanin (the rare blue colouring matter of pus), or from phosphate of the oxide of iron (Osc. Kollmann) are extremely rare. Such coloured sweats are called **chromidrosis**. *Bacteria* are frequently found, both in normal and in abnormal sweat, in yellow, blue, and red sweat. *Grape-sugar* occurs in the sweat in diabetes mellitus; uric acid and cystin very rarely; and in the sweat of stinking feet, leucin, tyrosin, valerianic acid, and ammonia. Stinking sweat (**Bromidrosis**) is due to the decomposition of the sweat, from the presence of a special micro-organism

(*Bacterium foetidum*—Thin). In the sweating stage of ague, butyrate of lime has been found, while, in the sticky sweat of acute articular rheumatism, there is more albumin (Anselmino), and the same is the case in artificial sweating (Leube); lactic acid is present in the sweat in puerperal fever.

The sebaceous secretion is sometimes increased, constituting *seborrhœa*, which may be local or general. It may be diminished (*Asteatosis cutis*). The sebaceous glands degenerate in old people, and hence the glancing of the skin (Rémy). If the ducts of the glands are occluded, the sebum accumulates. Sometimes the duct is occluded by black particles, or ultramarine (Unna) from the blue used in colouring the linen. When pressed out, the fatty worm-shaped secretion is called "comedo."

290. Cutaneous Absorption—Galvanic Conduction.

After long immersion in water, the superficial layers of the epidermis become moist and swell up. The skin is unable to absorb any substances, either salts or vegetable poisons, from *watery solutions* of these. This is due to the fat normally present on the epidermis and in the pores of the skin. If the fat be removed from the skin by alcohol, ether, or chloroform, absorption may occur in a few minutes (Parisot). According to Röhrig, all *volatile* substances, *e.g.*, carbolic acid and others, which act upon and corrode the epidermis, are capable of absorption.

When ointments are *rubbed* into the skin, so as to press the substance into the pores, absorption occurs, *e.g.*, potassium iodide in an ointment so rubbed in is absorbed, so is mercurial ointment. v. Voit found globules of mercury between the layers of the epidermis, and even in the chorium of a person who was executed, into whose skin mercurial ointment had been previously rubbed. The mercury globules, in cases of mercurial inunction, pass into the hair-follicles and ducts of the glands, where they are affected by the secretion of the glands, and transformed into a compound capable of absorption. An abraded or inflamed surface (*e.g.*, after a blister), where the epidermis is removed, absorbs very rapidly, just like the surface of a wound.

Gases.—Under normal conditions, minute traces of O are absorbed from the air; hydrocyanic acid, sulphuretted hydrogen—CO, CO₂, the vapour of chloroform and ether may be absorbed (Chaussier, Gerlach, Röhrig). In a bath containing sulphuretted hydrogen, this gas is absorbed, while CO₂ is given off into the water (Röhrig).

Absorption of watery solutions takes place rapidly through the skin of the *frog* (Guttmann, W. Stirling, v. Wittich). Even after the circulation is excluded and the central nervous system destroyed, much water is absorbed through the skin of the frog, but not to such an extent as when the circulation is intact (Spina).

Galvanic Conduction through the Skin.—If the two electrodes of a *constant* current be impregnated with a watery solution of certain substances and applied to the skin, and if the direction of the current be changed from time to time, strychnin

may be caused to pass through the skin of a rabbit in a few minutes, and that in sufficient amount to kill the animal (H. Munk). In man, quinine and potassium iodide have been introduced into the body in this way, and their presence detected in the urine. This process is called the *cataphoric action* of the constant current (§ 328).

291. Comparative—Historical.

In all **vertebrates**, the skin consists of chorium and epidermis. In some **reptiles**, the epidermis becomes horny, and forms large plates or scales. Similar structures occur in the edentata amongst mammals. The epidermal appendages assume various forms—such as hair, nail, spines, bristles, feathers, claws, hoof, horns, spurs, &c. The scales of some fishes are partly osseous structures. Many *glands* occur in the skin; in some amphibia they secrete mucus, in others the secretion is poisonous. Snakes and tortoises are devoid of cutaneous glands; in lizards the “leg-glands” extend from the anus to the bend of the knee. In the crocodile, the glands open under the margins of the cutaneo-osseous scales.

In **birds**, the cutaneous glands are absent; the “cocygeal glands” form an oily secretion for lubricating the feathers. The *civet glands*, at the anus of the civet cat, the preputial glands of the musk deer, the glands of the hare, and the pedal glands of ruminants, are really greatly developed sebaceous glands. In some invertebrata, the skin consisting of epidermis and chorium, is intimately united with the subjacent muscles, forming a musculo-cutaneous tube for the body of the animal. The cephalopoda have *chromatophores* in their skin, *i.e.*, round or irregular spaces filled with coloured granules. Muscular fibres are arranged radially around these spaces, so that when these muscles contract the coloured surface is increased. The change of colour in these animals is due to the play or contraction of these muscles (Brücke). Special glands are concerned in the production of the shells of the snail. The *annulosa* are covered with a chitinous investment (p. 508), which is continued for a certain distance along the digestive tract and the tracheæ. It is thrown off when the animal sheds its covering. It not only protects the animal, but it forms a structure for the attachment of muscles. In echinodermata, the cutaneous covering contains calcareous masses; in the holothurians, the calcareous structures assume the form of calcareous spicules.

Historical.—Hippocrates (born 460 B.C.) and Theophrastus (born 371 B.C.) distinguished the perspiration from the sweat; and, according to the latter, the secretion of sweat stands in a certain antagonistic relation to the urinary secretion and to the water in the fæces. According to Cassius Felix (97 A.D.), a person placed in a bath absorbs water through the skin; Sanctorius (1614) measured the amount of sweat given off; Alberti (1581) was acquainted with the hair-bulb; Donatus (1588) described hair becoming grey suddenly; Riolan (1626) showed that the colour of the skin of the negro was due to the epidermis.

Physiology of the Motor Apparatus.

292. Ciliary Motion.

(a.) **Muscular Movement.**—By far the greatest number of the movements occurring in our bodies is accomplished through the agency of muscular fibre, which, when it is excited by a stimulus, contracts—*i.e.*, it forcibly shortens and thus brings its two ends nearer together, while it bulges to a corresponding extent laterally. In muscle, the contraction takes place in a *definite* direction.

(b.) **Amœboid Movement.**—Motion is also exhibited by colourless blood-corpuscles, lymph-corpuscles, leucocytes, and some other corpuscles. In these structures we have examples of *amœboid* movement (§ 9), which is movement in an *indefinite* direction.

[(c.) **Ciliary Movement.**—There is also a peculiar form of movement, known as *ciliary movement*. There is a gradual transition between these different forms of movement. The *cilia* which are attached to the ciliated epithelium (Fig. 97, *b*) are the motor agents. **Ciliated epithelium** is widely distributed in the body, amongst others in the following situations:—In the nasal mucous membrane, except the olfactory region; the cavities accessory to the nose; the upper half of the pharynx, Eustachian tube, larynx, trachea and bronchi; in the uterus, except the lower half of the cervix; Fallopian tubes, vasa efferentia to the lower end of epididymis; ventricles of brain (child), and the central canal of the spinal cord.]

[The cilia are flattened blade-like or hair-like appendages attached to the free end of the cells. They are about $\frac{1}{3000}$ inch in length, and are apparently homogeneous and structureless. They are planted upon a clear non-contractile disc on the free end of the cell, and some observers state that they pass through this disc to become continuous with the protoplasm of the cell, or with the plexus of fibrils which pervades the protoplasm, so that by some observers (Klein) they are regarded as prolongations of the intra-epithelial plexus of fibrils. They are specially modified parts of an epithelial cell, and are contractile and elastic. They are colourless, tolerably strong, and are not stained by staining reagents, and are possessed of considerable rigidity and flexibility. They are always connected with the protoplasm of cells, and are never out-growths of the solid cell membranes. There may

be 10–20 cilia distributed uniformly on the free surface of a cell (Fig. 97).]

[Ciliary motion may be studied in the gill of a mussel, a small part of the gill being teased in *sea water*; or the hard palate of a frog, newly killed, may be scraped and the scraping examined in salt solution. On analysing the movement, all the cilia will be observed to execute a regular, periodic, to and fro rhythmical movement in a plane usually vertical to the surface of the cells, the direction of the movement being parallel to the long axis of the organ. The appearance presented by the movements of the cilia is sometimes described as a lashing movement, or like a field of corn moved by the wind. Each *vibration* of a cilium consists of a rapid forward movement or flexion, the tip moving more than the base, and a slower backward movement, the cilium again straightening itself. The forward movement is about twice as rapid as the backward movement. The *amplitude* of the movement varies according to the kind of cell and other conditions, being less when the cells are about to die, but it is the same for all the cilia attached to one cell, and is seldom more than 20° – 50° . There is a certain *periodicity* in their movement—in the frog they contract about 12 times per second (Engelmann). The result of the rapid forward movement is that the surrounding fluid, and any particles it may contain, are moved in the direction in which the cilia bend. All the cilia of adjoining cells do not move at once, but in regular succession, the movement travelling from one cell to the other, but how this *co-ordination* is brought about we do not know. At least it is quite independent of the nervous system, as ciliary movement goes on in isolated cells, and in man it has been observed in the trachea two days after death.]

[A ciliated epithelial cell is a good example of the physiological division of labour. It is derived from a cell which originally held motor, automatic, and nutritive functions all combined in one mass of protoplasm, but in the fully developed cell, the nutritive and regulative functions are confined to the protoplasm, while the cilia alone are contractile. If the cilia be separated from the cell, they no longer move. If, however, a cell be divided so that part of it remains attached to the cilia, the latter still move. The nucleus is not essential for this act. It would seem, therefore, that though the cilia are contractile, the motor impulse probably proceeds from the cell. Each cell can regulate its own nutrition, for during life they resist the entrance of certain coloured fluids.]

[Conditions for Movement.—In order that ciliary movement may go on it is essential that—(1) the cilia be connected with part of a cell; (2) moisture; (3) oxygen be present; and (4) the temperature is within certain limits.]

[Effect of Reagents.—Gentle *heat* accelerates the number and intensity of the movements, *cold* retards them. A temperature of 45°C . causes coagulation of their proteids, makes them permanently rigid, and kills them, just in the same way as

it acts on muscle (p. 631), causing heat-stiffening. *Weak alkalies* may cause them to contract after their movement is arrested or nearly so (Virchow), and any current of fluid in fact may do so. Lister showed that the vapour of *ether* and *chloroform* arrests the movements as long as the narcosis lasts, but if the vapour be not applied for too long a time, the cilia may begin to move again. The prolonged action of the vapour kills them. As yet we do not know any specific poison for cilia; atropin, veratrin, and curara acting like other substances with the same endosmotic equivalent (Engelmann).]

[**Functions of Cilia.**—The moving cilia propel fluids or particles along the passages which they line. By carrying secretions along the tubes which they line towards where these tubes open on the surface, they aid in *excretion*. In the respiratory passages, they carry outwards along the bronchi and trachea the mucus formed by the mucous glands in these regions. When the mucus reaches the larynx it is either swallowed or coughed up. That the cilia carry particles upwards in a spiral direction in the trachea has been proved by actual laryngoscopic investigation, and also by excising a trachea and sprinkling a coloured powder on its mucous membrane, when the coloured particles (Berlin blue or charcoal) are slowly carried towards the upper end of the trachea. In bronchitis the ciliated epithelium is shed, and hence the mucus tends to accumulate in the bronchi. They remove mucus from cavities accessory to the nose, and from the tympanum, while the ova are carried partly by their agency from the ovary along the Fallopian tube to the uterus. In some of the lower animals they act as organs of locomotion, and in others as adjuvants to respiration, by creating currents of water in the region of the organs of respiration.]

[**The Force of Ciliary Movement.**—Wyman and Bowditch found that the amount of work that can be done by cilia is very considerable. The work was estimated by the weight which a measured surface of the mucous membrane of the frog's hard palate was able to carry up an inclined plane of a definite slope in a given time.]

292a. Structure and Arrangement of the Muscles.

[Muscles are endowed with contractility, so that when they are acted upon by certain forms of energy or stimuli, they contract. There are two varieties of muscle—

- (1.) Striped, striated or (voluntary);
- (2.) Non-striped, smooth, organic or (involuntary).

Some muscles are completely under the control of the will, and are hence called "*voluntary*," and others are not directly subject to the control of the will, and are hence called "*involuntary*;" the former are for the most part striped, and the latter non-striped; but the heart-muscle, although striped, is an involuntary muscle.]

1. **Striped (Voluntary) Muscles.**—The surface of a muscle is covered with a connective-tissue envelope or *perimysium externum*, from which septa, carrying blood-vessels and nerves, the *perimysium internum* pass into the substance of the muscle, so as to divide it into bundles of fibres or *fasciculi*, which are fine in the eye-muscles and coarse in the glutei. In each such compartment or mesh, there lies a number of *muscular fibres* arranged more or less parallel to each other. [The fibres are held together by delicate connective-tissue or *endomysium*, which surrounds groups of the fibres; each fibre being, as it were, separated from its

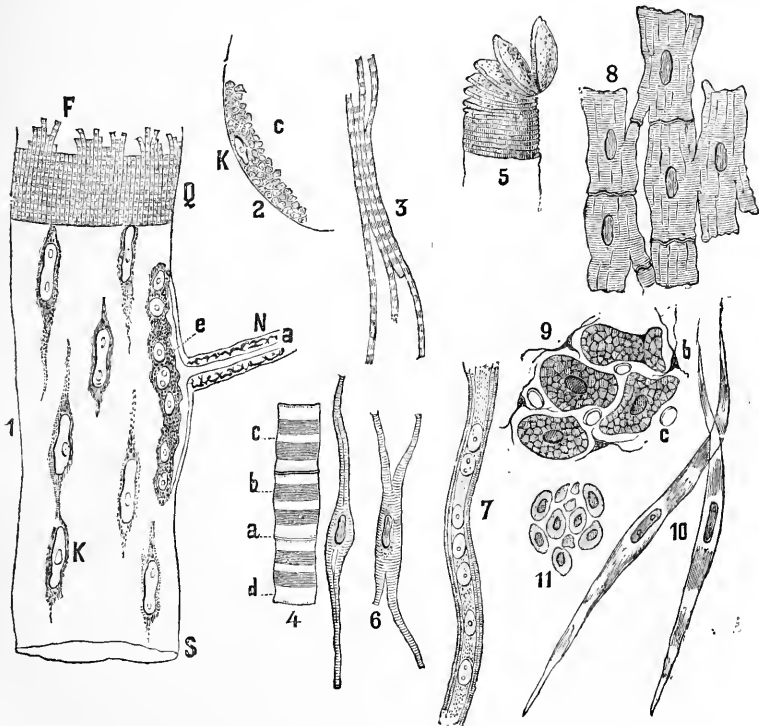

Fig. 231.

Histology of muscular tissue—1, diagram of part of a striped muscular fibre; S, sarcolemma; Q, transverse stripes; F, fibrillae; K, the muscular nuclei; N, a nerve-fibre entering it with *a*, its axis cylinder and Kühne's motorial end-plate, *e*, seen in profile; 2, transverse section of part of a muscular fibre, showing Cohnheim's areas, *c*; 3, isolated muscular fibrillae; 4, part of an insect's muscle greatly magnified; *a*, Krause-Amici's line limiting the muscular cases; *b*, the doubly-refractive substance; *c*, Hensen's disc; *d*, the singly-refractive substance; 5, fibre cleaving transversely into discs; 6, muscular fibre from the heart of a frog; 7, development of a striped muscle, from a human foetus at the third month; 8, 9, muscular fibres of the heart; *c*, capillaries; *b*, connective-tissue corpuscles; 10, smooth muscular fibres; 11, transverse section of smooth muscular fibres.

neighbour by excessively delicate fibrillar connective-tissue.] Each muscular fibre is surrounded with a rich plexus of *capillaries* [which form an elongated mesh-work, lying between adjacent fibres, but never penetrating the fibres which, however, they cross (Fig. 234). In a contracted muscle, the capillaries may be slightly sinuous in their course, but when a muscle is on the stretch these curves disappear. The capillaries lie in the endomysium, and near them are *lymphatics*.] Each muscular fibre receives a nerve-fibre. [Striped muscular fibres occur in the skeletal muscles, heart, diaphragm, pharynx, upper part of oesophagus, muscles of the middle ear and pinna, the true sphincter of the urethra, and external anal sphincter.]

A muscular fibre (Fig. 231, 1) is a more or less cylindrical or polygonal fibre, $11-67 \mu$ [$\frac{1}{100}$ to $\frac{1}{600}$ in.] in diameter, and never longer than 3-4 centimetres [$1-1\frac{1}{2}$ in.] (Rollett). Within short muscles, *e.g.*, stapedius, tensor tympani, or the short muscles of a frog, the fibres are as long as the muscle itself; within longer muscles, however, the individual fibres are pointed, and are united obliquely by cement-substance with a similar bevelled or pointed end of another fibre lying in the same direction. Muscular fibres may be isolated by maceration in nitric acid with excess of potassic chlorate (Budge), or by a 35 per cent. solution of caustic potash (Moleschott).

[Each muscular fibre consists of the following parts:—

1. *Sarcolemma*, an elastic sheath, with transverse partitions stretching across the fibre at regular intervals—the *membranes of Krause*;
2. The included *sarcous substance*;
3. The *nuclei* or muscle-corpuscles.]

Sarcolemma.—Each muscular fibre is completely enclosed by a colourless, structureless, transparent elastic sheath (Fig. 231, 1, S), which, chemically, is midway between connective- and elastic-tissue, and within it is the contractile substance of the muscle. [It has much more cohesion than the sarcous substance which it encloses, so that sometimes, when teasing fresh muscular tissue under the microscope, we may observe the sarcous substance torn across, with the unruptured sarcolemma stretching between the ends of the ruptured sarcous substance. If muscular fibres be teased in distilled water, sometimes fine clear blebs are seen along the course of the fibre, due to the sarcolemma being raised by the fluid diffusing under it. The sarcous substance, but not the sarcolemma, may be torn across by plunging a muscle into water at 55°C . and keeping it there for some time (Ranvier).]

Stripes.—The sarcous substance is marked transversely by alternate light and dim layers, bands, stripes, or discs (Fig. 231, 1, Q), so that each

fibre is said to be "*transversely striped*" (van Leeuwenhoek, 1679). [The stripes do not occur in the sarcolemma, but are confined to the sarcous substance, and they involve its whole thickness.]

[The animals most suited for studying the structure of the sarcous substance are some of the insects. The muscles of the water-beetle (*Dytiscus marginalis*), and the *Hydrophilus piceus* are well suited for this purpose. So is the crab's muscle. In examining a living muscle microscopically, no fluid except the muscle-juice should be added to the preparation, and very high powers of the microscope are required to make out the finer details.]

Bowman's Discs.—If a muscular fibre be subjected to the action of hydrochloric acid (1 per 1,000), or if it be digested by gastric juice, or if it be frozen, it tends to cleave transversely into *discs* (Bowman), which are artificial products, and resemble a pile of coins which has been knocked over (Fig. 231, 5).

Fibrillæ.—Under certain circumstances, a fibre may exhibit *longitudinal striation*. This is due to the fact that it may be split up longitudinally into an immense number of (1–1.7 μ in diameter) fine, contractile threads, the *primitive fibrillæ* (Fig. 231, 1, F), placed side by side (van Leeuwenhoek), each of which is also transversely striped, and they are so united to each other by semi-fluid cement-substance that, the transverse markings of all the fibrillæ lie at the same level. These fibrillæ, owing to mutual pressure, are prismatic in form, so that when a transverse section of a perfectly fresh muscular fibre is observed after it is frozen, the end of each fibre is mapped out into a number of small polygonal areas called **Cohnheim's areas** (Fig. 231, 2). Fibrillæ are easily obtained from insects' muscles, while those from a mammal's muscle are readily isolated by the action of dilute alcohol, Müller's fluid [or, best of all, $\frac{1}{8}$ per cent. solution of chromic acid] (Fig. 231, 3).

[When a living unaltered muscular fibre is examined microscopically, in its own juice, we observe the alternate dim and light transverse discs. A high power reveals the presence of a line running across the light disc (Fig. 232), and dividing it into two. It has been called **Dobie's line** (Rutherford), and by others it is regarded as due to the existence of a membrane, called *Krause's membrane*, which runs trans-

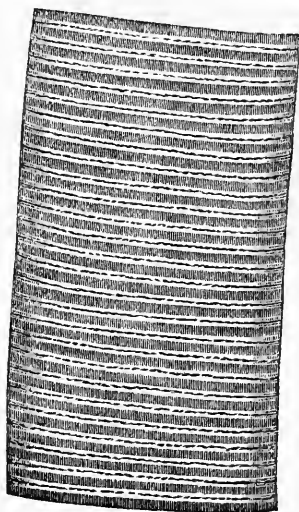

Fig. 232.

Portion of a human muscular fibre $\times 300$.

versely across the fibre, being attached all round to the sarcolemma, thus dividing each fibre into a series of *compartments* placed end to end.

These muscular **compartments** contain the sarcous substance, and in each compartment we find (1) a broad dim disc, which is the *contractile* part of the sarcous substance. It is doubly refractive (anisotropic), and is composed of Bowman's sarcous elements. On each end of this disc, and between it and Krause's membranes is a narrower, clear, homogeneous, and but singly refractile (isotropic), soft or fluid substance, which forms the *lateral* disc of Engelmann. In some insects it contains a row of refractive granules, constituting the *granular layer* of Flögel. If a muscular fibre be stretched and stained with logwood, the central part of the dim disc appears lighter in colour than the two ends of the same disc. This has been described as a separate disc, and is called the *median disc* of Hensen (Fig. 231, 4, c.)

[In an unaltered fibre, the dim broad stripe appears homogeneous, but after a time it cleaves throughout its entire extent in the long axis of the fibre into a number of prismatic elements or fibrils, the *sarcous elements of Bowman* (Fig. 231). These at first are prismatic, but as they solidify they shrink and seem to squeeze out of them a fluid, becoming at the same time more constricted in the centre. This separation into fibrils with an interstitial matter gives rise to the appearance seen on transverse section of a frozen muscle, and known as Cohnheim's areas (Fig. 231, 2, c). In all probability the cleavage also extends through the lateral discs, and thus fibrils are formed by longitudinal cleavage of the fibre.]

The nuclei or muscle-corpuscles are found immediately under the sarcolemma in all mammals, and their long axis lies in the long axis of the fibre (8-13 μ long, 3-4 μ broad). [In the muscles of the frog and some other animals, they lie in the substance of the fibre surrounded by a small amount of protoplasm.] When they occur immediately under the sarcolemma, they are more or less flattened and lie embedded in a small amount of protoplasm (Fig. 231, 1 and 2, K). They contain one or two nucleoli, and it is said that the protoplasm sends out fine processes, which unite with similar processes from adjoining corpuscles, so that according to this view, a branched protoplasmic net-work exists under the sarcolemma. [Each nucleus contains a plexus of fibrils. The nuclei are not seen in a perfectly fresh muscle, because until they have undergone some change, their refractive index is the same as that of the sarcous substance.] They become specially evident after the addition of acetic acid. Histogenetically, they are the remainder of the cells from which the muscular fibres were developed (Fig. 231, 7). According to M. Schultze, the sarcous substance is an inter-cellular substance differentiated and formed by their activity. Perhaps

they are the centres of nutrition for the muscular fibres. In amphibians, birds, fishes, and reptiles, they lie in the axis of the fibres between the fibrils.

It is said that the protoplasm of the muscle-corpuscles forms a fine network throughout the whole muscular fibre, the transverse branches taking the course of the lines of Krause or Dobie, and the longitudinal branches running in the interstices between Cohnheim's areas (Retzius, Bremer).

Relation to Tendons.—According to Toldt, the delicate connective-tissue elements, which cover the several muscular fibres, pass from the ends of the latter directly into the connective-tissue elements of the tendon. The end of the muscular fibre is perhaps united to the smooth surface or hollow end of the tendon by means of a special cement (Weismann—Fig. 233, S). In arthropoda, the sarcolemma passes directly into and becomes continuous with the tendon (Leydig, Reichert). The tendon itself consists of longitudinally-arranged bundles of white fibrous tissue with cells—*tendon cells*—embracing them. There is a loose capsule or sheath of connective-tissue—the *peritendineum* of Kollman—surrounding the whole, and carrying the blood-vessels, lymphatics, and nerves. The tendons move in the tendon-sheaths, which are moistened by a mucous fluid. In most situations, muscular fibres are attached by means of tendons to some fixed point, but in other situations (face), the ends terminate between the connective-tissue elements of the skin.

[**Blood-Vessels.**—Muscles being very active organs are richly supplied with blood. The blood supply of a muscle differs from some organs in not constituting an actual vascular unit, supplied only by one artery and one vein, thus being unlike the kidney, spleen, &c. Each muscle usually receives *several* branches from different arteries, and branches enter it at certain distances along its whole length. The artery and vein usually lie together in the connective-tissue of the perimysium, while the capillaries lie in the endomysium. The capillaries lie between the muscular fibres, but *outside* the sarcolemma, where they form an elongated rich plexus with numerous transverse branches (Fig. 234). The lymph to nourish the sarcous substance must traverse the sarcolemma to reach the former. In the red muscles of the rabbit (*e.g.*, semitendinosus), the capillaries are more wavy, while on the transverse branches of some of the capillaries, and on the veins (Ranvier), there are small, oval, saccular dilatations, which act as reservoirs for blood.]

[**Lymphatics.**—We know very little of the lymphatics of muscle, although the lymphatics of tendon and fascia have been carefully studied by Ludwig and Schweigger-Seidel (p. 416). There are lymphatics in the endomysium of the heart, which are continuous with those under the pericardium. This subject still requires further investigation. Compare the lymphatics of the fascia lata of the dog (Fig. 165, p. 416).]



Fig. 233.
Relation of a tendon, S, to its muscular fibre, 12.

Entrance of the Nerve.—The *trunk* of the motor nerve, as a rule, enters the muscle at its geometrical centre (Schwalbe); hence, the point of entrance in muscles with long, parallel, or spindle-shaped fibres lies near its middle.

If the muscle with parallel fibres is more than 2-3 centimetres [1 inch] in length, several branches enter its middle. In triangular muscles, the point of entrance of the nerve is displaced more towards the strong tendinous point of convergence of the muscular fibres. A nerve-fibre usually enters a muscle at the point where there is the least displacement of the muscular substance during contraction.

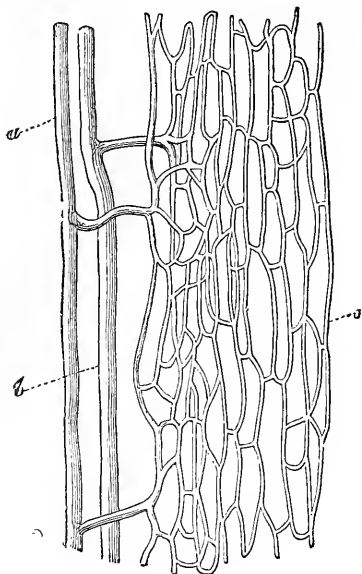

Fig. 234.

Injected blood-vessels of a human muscle—*a*, small artery; *b*, vein; *c*, capillaries $\times 250$ (Kölliker).

Motor Nerve.—Every muscular fibre receives a motor nerve-fibre (Fig. 231, 1, N). Each nerve does not contain originally as many motor nerve-fibres as there are muscular fibres in the muscle it enters; in the human eye-muscles, there are only 3 nerve-fibres to 7 muscular fibres; in other muscles (dog), 1 nerve-fibre to 40 or 80 (Tergast). Hence, when a nerve enters a muscle it must divide, which occurs dichotomously [at Ranvier's nodes], the structure undergoing no change until there are exactly as many nerve-fibres as muscular fibres. A nerve-

fibre enters each muscular fibre, and where it enters it forms an eminence (Doyère, 1840), the "*motorial end-plate*" (Fig. 231, 1, *e*). The neuro-

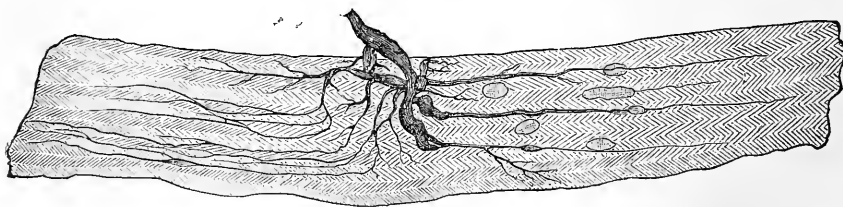

Fig. 235.

Inter-fibrillar terminations of a motor nerve in striped muscle. The nerve-fibrils are stained by gold chloride (after Gerlach).

lemma unites directly with the sarcolemma, the white substance of Schwann ceases, while the axis cylinder passes in and divides within the sarcolemma. There is an elevation of a protoplasmic nature

containing nuclei immediately under the sarcolemma at the entrance of the nerve (Kühne's end-plate). The branches of the axis cylinder traverse this mass, where they subdivide into fine fibrils recognisable only after the action of gold chloride (Fig. 235). These fibrils penetrate between the fibrillæ along the whole extent of the fibre, and perhaps they terminate in the anisotropic substance (Gerlach).

Sensory fibres also occur in muscles, and they are the channels for muscular sensibility. They seem to be distributed on the outer surface of the sarcolemma, where they form a branched plexus and wind round the muscular fibres (Arndt, Sachs); but, according to Tschiriew, the sensory nerves traverse the substance of the muscle, and after dividing dichotomously, end *only* in the aponeurosis, either suddenly or by means of a small swelling—a view confirmed by Rauber. The existence of sensory nerves in muscles is also proved by the fact that, stimulation of the central end of a motor nerve—*e.g.*, the phrenic—causes increase of the blood-pressure and dilatation of the pupil (Asp, Kowalewsky, Nawrocki), as well as by the fact that, when they are inflamed, they are painful. They of course do not degenerate after section of the anterior root of the spinal nerves.

Red and Pale Muscles.—In many fishes (skate), birds, and mammals (rabbits), there are two kinds of striped muscle (Krause), differing in colour, histological structure (Ranvier), and physiological properties (Kronecker and Stirling). Some are "*red*"—*e.g.*, the soleus and semitendinosus of the rabbit, and others "*pale*"—*e.g.*, the adductor magnus. In the *pale* muscles, the transverse striation is less regular, and their nuclei fewer, than in the red muscles (Ranvier).

[Spectrum.—The red colour of the ordinary skeletal muscle is due to hæmoglobin (Kühne), in the sarcous substance. This is proved by the fact that the colour is retained when all the blood is washed out of the vessels, when a thin muscle still shows the absorption-bands of hæmoglobin when examined with the spectroscope.]

[Myo-haematin.—M'Munn points out that, although most voluntary muscles owe their colour to hæmoglobin, it is accompanied by *myo-haematin* in most cases, and sometimes entirely replaced by it. Myo-haematin is found in the *heart* of vertebrates, and in some muscles of vertebrates and invertebrates.]

[In the frog's heart the fibres are fusiform and striped (Fig. 231, 6).]

Muscular Fibres of the Heart.—The mammalian cardiac muscle has certain peculiarities already mentioned (§ 43):—(1) It is striped, but it is involuntary; (2) it has no sarcolemma; (3) its fibres branch and anastomose; (4) the transverse striation is not so distinct, and it is sometimes striated longitudinally; (5) the nucleus is placed in the centre of each cell (see § 43).]

[Purkinje's Fibres.—These fibres, which form a plexus of grayish fibres under the endocardium of the heart of ruminants, have been described already (Fig. 236); the cells have, as it were, advanced only to a certain stage of development (p. 72).]

[The cardiac muscle, viewed from a *physiological* point of view,

stands mid-way between striped and unstriped muscle. Its contraction occurs slowly and lasts for a long time (p. 109), while, although it is transversely striped, it is involuntary.]

Development.—Each muscular fibre is developed from a uni-nucleated cell of the mesoblast, which elongates into the form of a spindle. As the cell elongates, the nuclei multiply. The superficial or parietal part of the cell-substance shows transverse markings (Fig. 231, 7), while the nuclei with a small

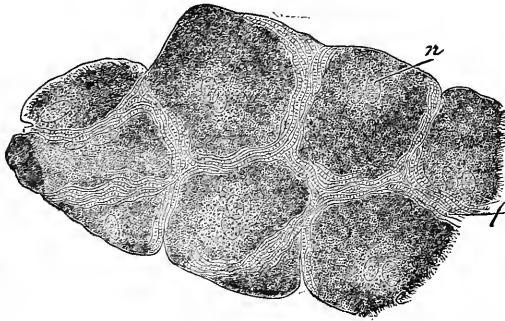

Fig. 236.

Purkinje's fibres isolated with dilute alcohol—*c*, cell; *f*, striated substance; *n*, nucleus $\times 300$.

amount of protoplasm are continuous along the axis of the fibre, where they remain in some animals. Young muscles have fewer fibres than those of adults, and the former are also smaller (Budge).

In developing muscles, the number of fibres is increased by the proliferation of the muscle-corpuscles, which form new fibres. Striped muscle, besides occurring in the corresponding organs of vertebrata, occurs in the iris and

choroid of birds. The arthropoda have only striped muscle, the molluscs, worms, and echinoderms, chiefly smooth muscles; in the latter, there are muscles with double oblique striation (Schwalbe).

2. Non-Striped Muscle (Involuntary)—Distribution.—[It occurs very widely distributed in the body, in the muscular coat of the lower half of the human œsophagus, stomach, small and large intestine, muscularis mucosæ of the intestinal tract, in the arteries, veins, and lymphatics, posterior part of the trachea, bronchi, infundibula of the lung, muscular coat of the ureter, bladder, urethra, vas deferens, vesiculæ seminalis, and prostate; corpora cavernosa and spongiosa penis, ovary, Fallopian tube, uterus, skin, ciliary muscle, iris, upper eyelid, spleen and capsule of lymphatic glands, tunica dartos of the scrotum, gall-bladder, in ducts of glands, and in some other situations.]

Structure.—Smooth muscular fibres consist of fusiform or spindle-shaped elongated cells, with their ends either tapering to fine points (Fig. 231, 10) or divided. These contractile fibre-cells may be isolated by steeping a piece of the tissue in a 30 per cent. solution of caustic potash, or a strong solution of nitric acid. They are $45\text{--}230\ \mu$ [$\frac{1}{600}$ to $\frac{1}{120}$ in.] in length, and $4\text{--}10\ \mu$ [$\frac{1}{6000}$ to $\frac{1}{2500}$ in.] in breadth. Each cell contains a solid oval elongated *nucleus*, which may contain one or more nucleoli. It is brought into view by the action of dilute acetic acid, or by staining reagents. The mass of the cell appears more or

less homogeneous, [and is surrounded by a thin elastic envelope]. In some places it shows longitudinal fibrillation. [This fibrillation is revealed more distinctly thus :—Place the mesentery of a newt (Klein) or the bladder of the *Salamandra maculata* (Flemming) in a 5 per cent. solution of ammonium chromate, and afterwards stain it with picrocarmine. Each cell consists of a thin *elastic sheath* (sarcolemma of Krause), enclosing a bundle of *fibrils* (F) which run in a longitudinal direction within the fibre (Fig. 237). They are continuous at the poles of the nucleus with the plexus of fibrils which lies within the nucleus, and, according to Klein, they are the contractile part, and when they contract the sheath becomes shrivelled transversely and exhibits what look like thickenings (S). These fibrils have been observed by Flemming in the cells while *living*. Sometimes the cells are branched, while in the frog's bladder they are triradiate.]

[Arrangement.—Sometimes the fibres occur singly, but usually they are arranged in groups, forming lamellæ, sheets, or bundles, or in a plexiform manner, the bundles being surrounded by connective-tissue.] A very delicate elastic cement-substance unites the individual cells to each other. [This cement may be demonstrated by the action of nitrate of silver. In transverse section (Fig. 231, 11) they appear oval or polygonal, with the delicate homogeneous cement between them; but, as the fibres are cut at various levels, the areas are unequal in size, and all of them, of course, are not divided at the position of the nucleus.]

They vary in length from $\frac{1}{100}$ to $\frac{1}{200}$ of an inch; those in the blood-vessels are short, while they are long in the intestinal tract, and especially in the pregnant uterus.

According to Engelmann, the separation of the smooth muscular substance into its individual spindle-like elements is a *post-mortem* change of the tissue. Sometimes transverse thickenings are seen, which are not due to transverse striation (Krause), but to a partial contraction (Meissner).

Blood-Vessels.—Occasionally they have a tendinous insertion. Non-striped muscle is richly supplied with blood-vessels, and the capillaries form elongated meshes between the fibres, [although it is not so vascular as striped muscles]. *Lymphatics* also occur between the fibres, while numerous *nerves* terminate in the tissue.

Motor Nerves.—According to J. Arnold, they consist of medullated and non-medullated fibres [derived from the sympathetic system] which form a plexus—the *ground plexus*—partly provided with ganglionic cells, and lying in the connective-tissue of the perimysium. [The fibres are



Fig. 237.

Non-striped muscular fibre, from the mesentery of a newt, after the action of ammonium chromate—N, nucleus; F, fibrils; S, markings in the sheath.

surrounded with an endothelial sheath.] Small branches [composed of bundles of fibrils] are given off from this plexus, forming the *intermediary plexus* with angular nuclei at the nodal points. It lies either immediately upon the musculature or in the connective-tissue between the individual bundles. From the intermediary plexus, the finest fibrillæ ($0.3-0.5 \mu$) pass off either singly or in groups, and reunite to form the *intermuscular plexus*, which lies in the cement-substance between the muscle-cells, to end, according to Frankenhäuser, in the nucleoli of the nucleus, or in the neighbourhood of the nucleus (Lustig). According to J. Arnold, the fibrils traverse the fibre and the nucleus, so that the fibres appear to be strung upon a fibril passing through their nuclei. According to Löwit, the fibrils reach only the interstitial substance, while Gscheidlen also observed that, the finest terminal fibrils, one of which goes to each muscular fibre, ran along the margins of the latter. The course of these fibrils can only be traced after the action of gold chloride.

Nerves of Tendon.—Within the tendons of the frog, there is a plexus of medullated nerve-fibres, from which brush-like divided fibres proceed, which ultimately end with a point in nucleated plates, the *nerve-flakes* of Rollett. According to Sachs, bodies like *end-bulbs* occur in tendons, while Rauber found *Vater's corpuscles* in their sheaths; Golgi found, in addition, *spindle-shaped terminal corpuscles*, which he regards as a specific apparatus for estimating tension.

293. Physical and Chemical Properties of Muscle.

1. The consistence of the sarcous substance is the same as that of living protoplasm, *e.g.*, of lymph-cells; it is semi-solid, *i.e.*, it is not fluid to such a degree as to flow like a fluid, nor is it so solid that, when its parts are separated, these parts are unable to come together to form a continuous whole. The consistence may be compared to a jelly at the moment when it is dissolved (*e.g.*, by heat). The power of *imbibition* is increased in a contracted muscle (Ranke).

Proofs.—The following facts corroborate the view expressed above—(a) The analogy between the function of the sarcous substance and the contractile protoplasm of cells (§9). (b) The so-called *Porret's phenomenon* (W. Kühne) which consists in this, that when a galvanic current is conducted through the living, fresh, sarcous substance, the contents of the muscular fibre exhibit a streaming movement from the positive to the negative pole (as in all other fluids), so that the fibre swells at the negative pole. (c) By the fact that wave-movements have been observed to pass along the muscular fibre. (d) Direct observation has shown that a small parasitic round worm (*Myxoryctes Weismanni*) moved freely in the sarcous substance within the sarcolemma, while the semi-solid mass closed up in the track behind it (W. Kühne, Eberth).

2. **Polarised Light.**—The *contractile substance* doubly refracts light, and is said to be *anisotropous*, while the ground-substance causes single refraction, and is *isotropous*. According to Brücke, muscle behaves like a doubly refractive, positively uniaxial body, whose optical axis lies in the long axis of the fibre. When a

muscular fibre is examined under the polarisation microscope, the doubly refractive substance is recognised by its appearing *bright* in the dark field of the microscope when the nicols are crossed. During contraction of the muscular fibre, the contractile part of the fibre becomes narrower, and at the same time broader, whilst the optical constants do not thereby undergo any change. Hence, Brücke concludes that the contractile discs are not simple bodies, like crystals, but must consist of a whole series of small, doubly refractive, elements arranged in groups, which change their position during contraction and relaxation. These small elements Brücke called **disdiaclasts**. According to Schipiloff, Danilewsky, and O. Nasse, the contractile anisotropic substance consists of myosin, which occurs in a crystalline condition, and represents the disdiaclasts. According to Engelmann, however, all contractile elements are doubly refractive, and the direction of contraction always coincides with the optical axis.

The investigations of v. Ebner have shown that, during the process of growth of the tissue, *tension* is produced—the tension of bodies subjected to imbibition—which results in double refraction, and so gives rise to the condition called anisotropic.

The chemical composition of muscle undergoes a great change after death, owing to the spontaneous coagulation of a proteid within the muscular fibres. As frogs' muscles may be frozen and thawed, and still remain contractile, they cannot, therefore, be greatly changed by the process of freezing. W. Kühne bled frogs, cooled their muscles to 10° or 7°C., pounded them in an iced mortar, and expressed their juice through linen. The juice so expressed, when filtered in the cold, forms a neutral, or alkaline, slightly yellowish, opalescent fluid, the so-called "*muscle-plasma*." Like blood-plasma, it coagulates spontaneously; at first it is like a uniform soft jelly, but soon becomes opaque; doubly refractive fibres and specks, similar to the fibrin of blood, appear in the jelly, and as these begin to contract, they squeeze out of the jelly an *acid* "*muscle-serum*." Cold prevents or delays the coagulation of the muscle-plasma; above 0°, coagulation occurs very slowly, and the rapidity of coagulation increases rapidly as the temperature rises, while coagulation takes place very rapidly at 40°C. in cold-blooded animals, or at 48°–50°C. in warm-blooded muscles. The addition of distilled water or an acid to muscle-plasma causes coagulation at once. The coagulated proteid, most abundant in muscle, and which arises from the doubly refractive substance, is called "*myosin*" (W. Kühne).

Myosin.—It is a globulin (p. 502), and is soluble in strong (10 per cent.) solutions of common salt, and is again precipitated from such a solution by dilution with water, or by the addition of very small quantities of acids (0.1–0.2 per cent. lactic or hydrochloric acid). It is also soluble in dilute alkalies or slightly stronger acids (0.5 per cent. lactic or hydrochloric acid), and also in 13 per cent. ammonium chloride solution. Like fibrin, myosin rapidly decomposes H_2O_2 . When treated with dilute hydrochloric acid and heat, it is changed into syntonin (p. 503).

Danilewsky succeeded in partly changing syntonin into myosin by the action of milk of lime and ammonium chloride. Myosin occurs in other animal structures (cornea), nay, even in some vegetables (O. Nasse).

Muscle-serum still contains three proteids (2·3–3 per cent.), viz.:—
 1. *Alkali-albuminate*, which is precipitated on adding an acid, even at 20–24°C. 2. Ordinary *serum-albumin* 1·4–1·7 per cent. (§ 32, a), which coagulates at 75°C. 3. An albuminate which coagulates at 45°C.

The other chemical constituents of muscle have been referred to in treating of flesh (§ 233). 1. Brücke found traces of pepsin and peptone in muscle-juice; Piotrowsky, a trace of a diastatic ferment. 2. In addition to volatile *fatty acids* (formic, acetic, butyric), there are two isomeric forms of *lactic acid* (C₃H₆O₃) present in muscle with an acid reaction:—(a) *Ethylidene-lactic acid*, in the modification known as right rotatory *sarcolactic* or *paralactic acid*, which occurs only in muscles, and some other animal structures. (b) *Ethylene-lactic acid* in small amount (§ 251, 3 c). It was formerly assumed that lactic acid is formed by fermentation from the carbohydrates of the muscle (glycogen, dextrin, sugar), and Maly has observed that paralactic acid is occasionally formed when these bodies undergo fermentation. According to Böhm, however, the glycogen of muscle does not pass into lactic acid, as during rigor mortis, if putrefaction be prevented, the amount of glycogen does not diminish. If muscle be suddenly boiled or treated with strong alcohol, the ferment is destroyed, and hence the acidification of the muscular tissue is prevented (du Bois-Reymond). *Acid potassium phosphate* also contributes to the acid reaction. 3. *Carnin* (C₇H₈N₄O₃) which is changed by bromine or nitric acid into sarkin, occurs to the extent of 1 per cent. in Liebig's extract of meat (Weidel). 4. Only 0·01 per cent. of *urea* (Haycraft). 5. *Glycogen* occurs to the amount of over 1 per cent. after copious flesh-feeding, and to 0·5 per cent. during fasting. It is stored up in the muscles, as well as in the liver, during digestion, but it disappears during hunger. It is perhaps formed in the muscles from proteids (§ 174, 2). 6. *Lecithin* derived in part from the motor-nerve endings (§ 23 and § 251). 7. The *gases* are CO₂ (15–18 vol. per cent.), partly absorbed, partly chemically united; some absorbed N, but no O, although muscle continually absorbs O from the blood passing through it (L. Hermann). The muscles contain a substance whose decomposition yields CO₂. When muscles are exercised, this substance is used up, so that severely fatigued muscles yield less CO₂ (Stinzing).

294. Metabolism in Muscle.

I. A passive muscle continually absorbs a certain amount of O from the blood flowing through its capillaries, and returns a certain amount

of CO_2 to the blood-stream. The amount of CO_2 given off is less than corresponds to the amount of O absorbed. Excised muscles freed from blood exhibit an analogous but diminished gaseous exchange (du Bois-Reymond, G. Liebig). As an excised muscle remains longer excitable in O or in air than in an atmosphere free from O, or in indifferent gases (Al. v. Humboldt), we must conclude that the above-named gaseous exchange is connected with the normal metabolism, and is a condition on which the life and activity of the muscle depends.

This exchange of gases must be distinguished from the putrefactive phenomena due to the development of living organisms in the muscle. These putrefactive phenomena are also connected with the consumption of O and the excretion of CO_2 , and occur soon after death (L. Hermann).

II. In an active muscle, the blood-vessels are always *dilated* (Ludwig and Sezelkow)—a condition pointing to a more lively material exchange in the organ. Hence, the active muscle is distinguished from the passive one by a series of chemical transformations.

1. Reaction.—The neutral or feebly alkaline reaction of a passive muscle (also of the non-striped variety) passes into an *acid* reaction during the activity of the muscle, owing to the formation of paralactic acid (du Bois-Reymond, 1859); the degree of acidity increases up to a certain extent, according to the amount of work performed by the muscle (R. Heidenhain). The acidification is due, according to Weyl and Zeitler, to the phosphoric acid produced by the decomposition of lecithin and (? nuclein).

2. Formation of CO_2 .—An active muscle excretes considerably more CO_2 than a passive one: (*a*) active muscular exertion on the part of a man or of animals increases the amount of CO_2 given off by the lungs (p. 258); (*b*) venous blood flowing from a tetanised muscle of a limb contains more CO_2 , more CO_2 being formed than corresponds to the O, which has simultaneously been absorbed (Ludwig and Sezelkow). The same result is obtained when blood is passed through an excised muscle artificially; (*c*) an excised muscle caused to contract excretes more CO_2 (Matteucci, Valentin).

3. Consumption of Oxygen.—An active muscle uses up more O—(*a*) when we do muscular work, the body absorbs much more O (p. 448)—even 4–5 times as much (Regnault and Reiset); (*b*) venous blood flowing from an active muscle of a limb contains less O (Ludwig, Sezelkow, and Al. Schmidt). Nevertheless, the increase of O used up by the active muscle is not so great as the amount of CO_2 given off (v. Pettenkofer and v. Voit).

As yet, it is not possible to prove by gasometric methods, that O is used up in an excised muscle free from blood. Indeed, the presence of O does not seem to be absolutely necessary for the activity of

muscle during short periods, as an excised muscle may continue to contract in a vacuum, or in a mixture of gases free from O, and no O can be obtained from muscular tissue (L. Hermann). A frog's muscles rob easily reducible substances of their O; they discharge the colour of a solution of indigo; muscles which have rested for a time, acting less energetically than those which have been kept in a state of continued activity (Grützner, Gscheidlen).

4. **Glycogen.**—The amount of glycogen (0.43 per cent. in the muscles of a frog or rabbit) and grape-sugar is diminished in an active muscle (O. Nasse, Weiss), but muscles devoid of glycogen do not lose their excitability and contractility. Hence, glycogen is certainly not the direct source of the energy in an active muscle. Perhaps it is to be sought for in an as yet unknown decomposition product of glycogen (Luchsinger).

5. **Extractives.**—An active muscle contains less extractive substances soluble in water, but more extractives soluble in alcohol (v. Helmholtz, 1845); it also contains less of the substances which form CO₂ (Ranke); less fatty acids (Sczelkow); less kreatin and kreatinin (v. Voit).

6. During contraction, the amount of water in the muscular tissue increases, while that of the blood is correspondingly diminished (J. Ranke). The solid substances of the blood are increased, while they (albumin) are diminished in the lymph (Fano).

7. **Urea.**—The amount of urea excreted from the body is not materially increased during muscular exertion (p. 629)—v. Voit, Fick, and Wislicenus. According to Parkes, however, although the excretion of urea is not increased immediately, yet after 1–1½ days there is a slight increase. The amount of work done cannot be determined from the amount of albumin which is changed into urea.

During the activity of a muscle, *all* the groups of the chemical substances present in muscle undergo more rapid transformations (J. Ranke). It is still a matter of doubt, therefore, whether we may assume that the kinetic energy of a muscle is chiefly due to the transformation of the chemical energy of the carbohydrates which are decomposed or used up in the process of contraction. As yet we do not know whether the glycogen is supplied by the blood-stream to the muscles, perhaps from the liver (p. 350), or whether it is formed within the muscles themselves from some unknown derivative of the proteids. The normal circulation is certainly one of the conditions for the formation of glycogen in muscle, as glycogen diminishes after ligature of the blood-vessels (Chandelon). A muscle containing *blood* is capable of doing more work than one devoid of blood (Ranke), and even in the intact body, more blood is always supplied to the contracted muscles.

[Relation of Muscular Work to Urea.—Ed. Smith, Parkes, and others have made numerous investigations on this subject. Fick and Wislicenus (1866) ascended the Faulhorn, and for seventeen hours before the ascent and for six hours after the ascent, no proteid food was taken—the diet consisting of cakes made of fat, sugar, and starch. The urine was collected in three periods, as follows:—

	Fick.	Wislicenus.
1. Urea of 11 hours before the ascent, .	238·55 grs.	221·05 grs.
2. „ 8 „ during „ .	109·44 „ } 189·77	103·46 „ } 183·35
3. „ 6 „ after „ .	80·33 „ }	79·89 „ }

A hearty meal was taken after this period, and the urine of the next 11 hours after the period of rest contained 159·15 grains of urea (Fick), and 176·71 (Wislicenus). All the experiments go to show that, the amount of urea excreted in the urine is far more dependent upon the nitrogen ingested, *i. e.*, the nature of the food, than upon the decomposition of the muscular substance. A vegetable diet diminishes, while an animal diet greatly increases, the amount of urea in the urine.]

295. Rigor Mortis.

Cause.—Excised striped, or smooth muscles, and also the muscles of an intact body, at a certain time after death, pass into a condition of rigidity—*cadaveric rigidity* or *rigor mortis*. When all the muscles of a corpse are thus affected, the whole cadaver becomes completely stiff or rigid. The *cause* of this phenomenon depends upon the spontaneous coagulation of a proteid (Brücke), *viz.*, the myosin of the muscular fibre (Kühne), in consequence of the formation of a small amount of an acid. Under certain circumstances, the coagulation of the other proteids of the muscle may increase the rigidity. During the process of coagulation, heat is set free (*v.* Walther, Fick—§ 223), owing to the passage of the fluid myosin into the solid condition, and also to the simultaneous and subsequently increased density of the tissue.

Properties of a Muscle in Rigor Mortis.—It is shorter, thicker, and somewhat denser (Schmulewitsch, Walter); stiff, compact, and solid; turbid and opaque (owing to the coagulation of the myosin); incompletely elastic, less extensible, and more easily torn or ruptured; it is completely inexcitable to stimuli; the muscular electrical current is abolished (or there is a slight current in the opposite direction); its reaction is *acid*, owing to the formation of both lactic acids (*p.* 626) and glycerin-phosphoric acid (Diakanow), and it develops *free* CO₂. When an incision is made into a rigid muscle, fluid (muscle-serum) appears spontaneously in the wound.

The first formed lactic acid converts the salts of the muscle into acid salts; thus potassium lactate and acid potassium phosphate are formed from potassium phosphate. The lactic acid, which is formed thereafter, remains free and ununited in the muscle.

Amount of Glycogen.—The newest observations of Böhm are against the view that, during rigor mortis, a partial or complete transformation of the glycogen into sugar and then into lactic acid takes place. During digestion, a temporary storage of glycogen occurs in the muscles as well as in the liver, so that about as much is found in the muscles as in the liver. There is no diminution of the glycogen when rigidity takes place, provided putrefaction be prevented; so that the lactic acid of rigid muscles cannot be formed from glycogen, but more probably it is formed from the decomposition of the albuminates (Demant, Böhm).

The amount of acid does not vary, whether the rigidity occurs rapidly or slowly (J. Ranke); when acidification begins, the rigidity becomes more marked, owing to the coagulation of the alkali-albuminate of the muscle. Less CO_2 is formed from a rigid muscle, the more CO_2 it has given off previously, during muscular exertion. A rigid muscle gives off N, and absorbs O. In a cadaveric rigid muscle, *fibrin-ferment* is present (Al. Schmidt and others). It seems to be a product of protoplasm, and is never absent where this occurs (Rauschenbach).

[Thus there is a marked analogy between the coagulation of the blood and that of muscle. In both cases, a fluid body yields a solid body, fibrin from blood, and myosin from muscle, and there are many other points of analogy (p. 632).]

Stages of Rigidity.—Two stages are recognisable in cadaveric muscles:—In the *first stage*, the muscle is rigid, but still excitable; in this stage the myosin seems to be in a jelly-like condition. Restitution is still possible during this stage. In the *second stage*, the rigidity is well pronounced, with all the phenomena above mentioned.

The onset of the rigidity varies in man from 10 minutes to 7 hours; its *duration* is equally variable, 1–6 days. After the cadaveric rigidity has disappeared, the muscles, owing to further decompositions and an alkaline reaction, become soft and the rigidity disappears (Nysten, Sommer). The onset of the rigidity is always preceded by a loss of nervous activity. Hence, the muscles of the head and neck are first affected, and the other muscles in a descending series (§ 325). Disappearance of the rigidity occurs first in the muscles first affected (Nysten). Great muscular activity before death (*e.g.*, spasms of tetanus, cholera, strychnin, or opium poisoning) causes rapid and intense rigidity; hence, the heart becomes rigid relatively rapidly, and strongly.

Hunted animals may become affected within a few minutes after death. Usually the rigidity lasts longer the later it occurs. Rigidity does not occur in a foetus before the seventh month. A frog's muscle cooled to 0°C . does not begin to exhibit cadaveric rigidity for 4–7 days.

Stenson's Experiment.—The *amount of blood* in a muscle has a marked effect upon the onset of the rigidity. Ligature of the muscular arteries

causes in all mammals, at first for several minutes, a continued increased muscular excitability (muscle-substance as such), and then a rapid fall of the excitability (Schmulewitsch). Thereafter, rigidity occurs, the one stage following closely upon the other (Swammerdam, Nic. Stenson, 1667). If the artery going to a muscle be ligatured, Stannius observed that the excitability of the motor nerves disappeared after an hour, that of the muscular substance after 4–5 hours, and then cadaveric rigidity set in.

When the blood-vessels of a muscle are occluded, by coagulation taking place within them (Landois), rigidity of the muscles is produced (p. 201). Finch observed a case in which rigidity of the muscles of the lower limbs took place during life, there being at the same time complete loss of sensibility. The blood-vessels had undergone degeneration, and the heart's action was very feeble. True cadaveric rigidity may be produced by too tight bandaging; the muscles are paralysed, rigid, and break up into flakes, while the contents of the fibre are afterwards absorbed (R. Volkmann).

If the circulation be re-established during the first stage of the rigidity, the muscle soon recovers its excitability (Stannius). When the second stage has set in, restitution is impossible (Kühne). In cold-blooded animals, cadaveric rigidity does not occur for several days, after ligaturing the blood-vessels. Brown-Séguard, by injecting fresh oxygenated blood into the blood-vessels, succeeded in restoring the excitability of the muscles of a human cadaver four hours after death, *i.e.*, during the first stage of cadaveric rigidity. Ludwig and Al. Schmidt found that, the onset of cadaveric rigidity was greatly retarded in excised muscles, when arterial blood was passed through their blood-vessels. Blood deprived of its O did not produce this effect. Cadaveric rigidity occurs relatively early after severe hæmorrhage. If a weak alkaline fluid be conducted through the dead muscles of a frog, cadaveric rigidity is prevented (Schipiloff).

Section of Nerves.—Preliminary *section of the motor nerves* causes a later onset of the rigidity in the corresponding muscles (Brown-Séguard, Heineke). Perhaps this is caused by the greater accumulation of blood in the paralysed parts (due to section of the vaso-motor nerves). In fishes, whose medulla oblongata is suddenly destroyed, cadaveric rigidity occurs much more slowly than in those animals that die slowly (Blane).

Rigidity may be produced artificially by various reagents:—

1. Heat [“heat-stiffening” (Pickford)] causes the myosin to coagulate at 40°C. in cold-blooded animals, in birds about 53°C., and in mammals at 48–50°C. The protoplasm of plants and animals, *e.g.*, of the amœba, is coagulated by heat, giving rise to heat-rigor.

Schmulewitsch found that the longer a muscle had been excised from the body, the greater was the heat required to produce stiffening. Heat-stiffening differs from

cadaveric rigidity thus: a 13 per cent. solution of ammonium chloride dissolves out the myosin from a cadaveric rigid muscle, but not from one rendered rigid by heat (Schpiloff). If the rigid cadaveric muscles of a frog be heated, another proteid coagulates at 45°, and lastly at 75° the serum-albumin itself. Hence, both processes together make the muscle more rigid (p. 629).

2. When a muscle is saturated with **distilled water**, it produces "**water-stiffening**"—an acid reaction being developed at the same time (Swammerdam, Pickford).

Muscles rendered stiff by water still exhibit electro-motive phenomena, which muscles rendered rigid by other means do not (Biedermann).

If the upper limb of a frog be ligatured, deprived of its skin, and dipped in warm water, it becomes rigid. If the ligature be removed and the circulation re-established, the rigidity may be partially set aside. If there be well-marked rigidity, it can only be set aside by placing the limb in a 10 per cent. solution of common salt, which dissolves the coagulum of myosin (Preyer).

3. Acids, even CO_2 , rapidly produce "**acid-stiffening**," which is probably different from ordinary stiffening, as such muscles do not evolve any free CO_2 (L. Hermann). The injection of 0.1–0.2 per cent. solutions of lactic or hydrochloric acid into the muscles of a frog produces stiffening at once, which may be set aside by injecting 0.5 per cent. solution of an acid, or by a solution of soda, or by 15 per cent. solution of ammonium chloride. The acids form a compound with the myosin (Schpiloff).

4. Freezing and thawing a part alternately, rapidly produces stiffening; and it is aided by mechanical injuries.

Poisons.—Rigor mortis is favoured by quinine, caffeine, digitalin, veratrin, hydrocyanic acid, ether, chloroform, the oils of mustard, fennel, and aniseed; direct contact of muscular tissue with potassium sulphocyanide (Bernard, Setschenow), ammonia, alcohol, and metallic salts.

Position of the Body.—The attitude of the body during cadaveric rigidity is generally that occupied at death; the position of the limbs is the result of the varying tensions of the different muscles. During the occurrence of rigor mortis, a limb, or more frequently the arm and fingers, may move (Sommer). Thus, if stiffening occurs rapidly and firmly in certain groups of muscles, this may produce movements, as is sometimes seen in cholera. If cadaveric rigidity occurs very rapidly, the body may occupy the same position which it did at the moment of death, as sometimes happens on the battle-field. In these cases it does not seem that a contracted condition of the muscle passes at once into rigor mortis; but between these two conditions, according to Brücke, there is always a very short relaxation.

Muscles which have been plunged into boiling water do not undergo rigor mortis, neither do they become acid (du Bois-Reymond), nor evolve free CO_2 (L. Hermann).

Analogy between Contraction and Rigidity.—L. Hermann has drawn attention to the analogy which exists between a muscle in a state of contraction and one in a state of cadaveric rigidity—both evolve CO_2 and the other acids from the same source. The form of the contracted and the stiffened muscle is shorter and thicker; both are denser, less elastic, and evolve heat; in both cases, the muscular contents behave negatively as regards their electro-motive force, in refer-

ence to the unaltered, living, resting substance. Hence, he is inclined to regard a muscular contraction as a temporary, physiological, rapidly disappearing rigor, whilst other observers regard stiffening as in a certain sense the last flickering act of a living muscle.

Work done by Rigidity.—A muscle in the act of becoming stiff will lift a weight, but the height to which it is lifted is greater with small weights, but less with heavier weights, than when a living muscle is stimulated with a maximal stimulus.

Disappearance of the Rigidity.—When rigor mortis passes off, there is a considerable amount of acid formed in the muscle, which dissolves the coagulated myosin. After a time *putrefaction* sets in, accompanied by the presence of micro-organisms and the evolution of ammonia and putrefactive gases (H_2S , N , CO_2 —§ 184).

According to Onimus, the loss of excitability which precedes the onset of rigor mortis occurs in the following order in man: left ventricle, stomach, intestine (55 minutes); urinary bladder—right ventricle (60 min.); iris (105 min.); muscles of face and tongue (180 min.); the extensors of the extremities about 1 hour before the flexors; the muscles of the trunk (5-6 hours). The œsophagus remains excitable for a long time (§ 325).

296. Muscular Excitability.

By the term *excitability* or *irritability* of a muscle, is meant that property in virtue of which a muscle shortens when it is stimulated. The condition of excitement is the active condition of a muscle produced by the application of stimuli, and is usually indicated by the act of contraction. Stimuli are simply various forms of energy, and they throw the muscle into a state of excitement, while at the moment of activity, the chemical energy of the muscle is transformed into work and heat, so that stimuli act as "*discharging forces*." The normal temperature of the body is most favourable for maintaining the normal muscular excitability; the excitability varies as the temperature rises or falls.

As long as the *blood-stream* within a muscle is uninterrupted, the first effect of stimulation of a muscle is to increase its energising power, partly because the circulation is more lively and the blood-vessels are dilated, but after a time, the energising power is diminished.

Even in excised muscles, especially when the large nerve-trunks have already lost their excitability, the excitability is increased after a stimulus, so that the application of a series of stimuli of the same strength causes a series of contractions which are greater than at first (Wundt). Hence, we account for the fact that, although the first feeble stimulus may be unable to discharge a contraction, the second may, because the first one has increased the muscular excitability (Fick).

Effect of Cold.—If the muscles of a frog (du Bois-Reymond), or tortoise (Brücke), be kept in a cool place, they may remain excitable for 10 days, while the muscles of warm-blooded animals cease to be excitable after $1\frac{1}{2}$ – $2\frac{1}{2}$ hours. (For the heart see § 55, p. 96.) A muscle when stimulated *directly*, always remains excitable for a longer time when its motor nerve is already dead.

[**Independent Muscular Excitability.**—Since the time of Albrecht v. Haller and R. Whytt, physiologists have ascribed to muscle a condition of excitability which is entirely independent of the existence of motor nerves, and which depends on certain constituents of the sarcous substance. Excitability, or the property of responding to a stimulus, is a widely distributed function of protoplasm or its modifications. A colourless blood-corpuscle or an amœba is excitable, and so are secretory- and nerve-cells. In the first cases, the application of a stimulus results in motion in an indefinite direction, in the second in the formation of a secretion, and in the third in the discharge of nerve-energy. In the case of muscle, a stimulus causes movement in a definite direction, called a contraction, and depending on the contractility of the sarcous substance. There are many considerations which show that excitability is independent of the nervous system, although in the higher animals, nerves are the usual medium through which the excitability is brought into action. Thus, plants are excitable, and they contain no nerves.]

Numerous experiments attest the “*independent excitability*” of muscle:

1. There are chemical stimuli, which do not cause movement when applied to motor nerves, but do so when they are applied directly to muscle; ammonia, lime water, carbolic acid.
2. The ends of the sartorius of the frog, in which no nerve terminations are observable by means of the microscope, contract when they are stimulated directly (Kühne).
3. Curara paralyses the extremities of the motor nerves, while the muscles themselves remain excitable (Cl. Bernard, Kölliker). The action of *cold*, or *arrest of the blood supply* in an animal, abolishes the excitability of the nerves, but not of the muscles at the same time.
4. After section of its nerve, a muscle still remains excitable, even after the nerves have undergone fatty degeneration (Brown-Séquard, Bidder).
5. Sometimes electrical stimuli act only upon the nerves and not upon the muscle itself (Brücke).
- [6. The foetal heart contracts rhythmically before any nervous structures are discoverable in it.]

[**The Action of Curara.**—Curara, woorali, urari, or Indian arrow poison is the inspissated juice of a plant belonging to the same order as strychnia. It is obtained in South America. A watery extract of the drug, when injected under the skin or into the blood of an animal, acts chiefly upon the motor nerves, and does not affect the muscular contractility. An active substance, *curarin*, has been isolated from it (see also p. 638). Poison a frog by injecting a few milligrammes into

the dorsal lymph-sac. In a few minutes, after the poison is absorbed, the animal ceases to support itself on its fore-limbs; it lies flat on the table, its limbs are paralysed, and so are the respiratory movements in the throat. When completely under the action of the poison, the frog lies in any position, limp and motionless, neither exhibiting voluntary nor reflex movements. If the brain be destroyed and the skin removed, on faradising the sciatic nerve no contraction of the muscles of the hind-limb occurs, but if the electrical stimulus be applied directly to the muscles, they contract, thus proving that curara poisons the *motor nerves* and not the muscles. If the dose be not too large, the heart still continues to beat, and the vaso-motor nerves remain active.]

[But it is the terminal or *intra-muscular* portions of the nerves, not the nerve-trunk, which are paralysed.

Ligature the sciatic artery, or, better still, tie all the parts of the hind-limb of a frog at the upper part of thigh, except the sciatic nerve. Inject curara into the dorsal lymph-sac. The poisoned blood will, of course, circulate in every part of the body except the ligatured limb. The animal can still at a certain stage of the poisoning pull up the non-poisoned limb, while it cannot move the poisoned one. In this case, although poisoned blood has circulated in the sacral and intra-abdominal parts of the nerves, yet they are not paralysed, so that the poison does not act on this part of the trunk of the nerve. But we can show that, it does not act on any part of the extra-muscular trunk of the nerve. This is done by ligaturing the arteries going to the gastrocnemius muscle, and then poisoning the animal. On stimulating the nerve on the ligatured side, the gastrocnemius of that side contracts, although the whole length of the nerve-trunk has been supplied by poisoned blood. Therefore, it is the *intramuscular terminations* of the nerves which are acted on.]

[By means of the following arrangement we may prove that the actual *terminations* are paralysed. Ligature the sciatic artery of one leg of a frog, and then inject curara into a lymph-sac. After the animal is fully

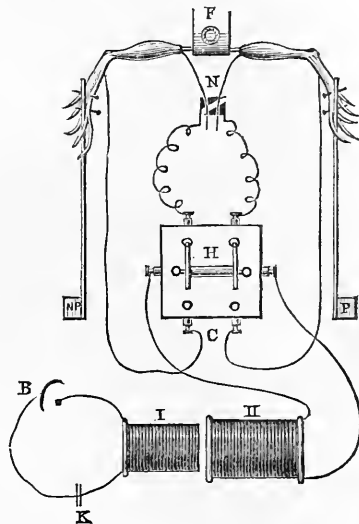

Fig. 23S.

Scheme of the curara experiment—B, battery; I, primary, II, secondary spiral; N, nerves; F, clamp; N P, non-poisoned leg; P, poisoned leg; C, commutator; K, key (after Rutherford).

poisoned, dissect out the whole length of the sciatic nerve in both legs, leaving all the muscles below the knee-joint, then clean and divide the femur at its middle. Pin a straw flag to each limb, and fix both femora in a clamp, or muscle-forceps, with the gastrocnemii uppermost, as in Fig. 238. Place the two nerves, N, on du Bois-Reymond's electrodes (Fig. 239) attached to two wires coming from a commutator, C (Fig. 238). From two other binding screws of the commutator, two wires pass and are made to pierce the gastrocnemii. The other two binding screws of the commutator are connected with the secondary coil of a du Bois-Reymond's induction machine (§ 330). The bridge of the commutator can be turned so as to pass the current either through both muscles or both nerves—the latter is the case in the diagram (H). When both *nerves* are stimulated, only the *non-poisoned leg* (N P) contracts. Reverse the commutator, and pass the current through both *muscles*, when *both contract*.]

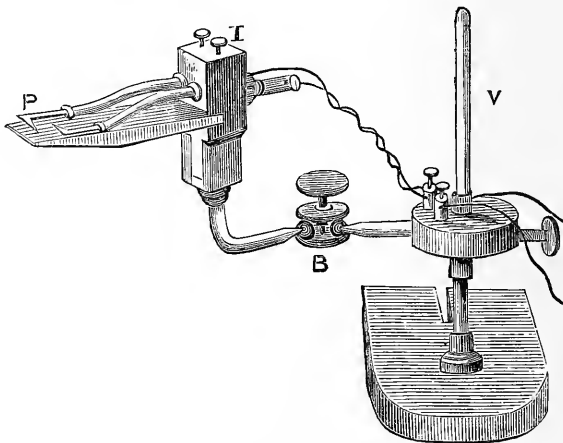

Fig. 239.

du Bois-Reymond's platinum electrodes—The nerve is placed over the two pieces of platinum, P, which rest on vulcanite; B, universal joint; V, support (Elliott Brothers).

[*Rosenthal's Modification*.—Pull the secondary coil far away from the primary, and pass the current through both muscles. Gradually approximate the secondary to the primary coil, and in doing so, it will be found that, the non-poisoned leg contracts first, and on continuing to push up the secondary coil, both limbs contract. Thus the poisoned limb does not respond to so feeble a faradic stimulus as the non-poisoned one, a result which is not due to the action of the curara on the excitability of the muscle. The non-poisoned limb responds to a feebler stimulus because its motor-nerve terminations are not paralysed,

while the poisoned leg does not do so, because the motor terminations are paralysed. A feebler induced shock suffices to cause a muscle to contract when it is applied to the nerve than when it is applied to the muscle itself directly. In large doses, curara also affects the spinal cord.]

The whole question of "*specific muscular excitability*" has entered upon a new phase, owing to the researches of Gerlach on the terminations of motor nerves in muscle. Since it has been shown that, a nerve-fibre after penetrating the sarcolemma, breaks up into inter-fibrillar threads, which come into direct relation with the sarcous substance, we can scarcely speak of an isolated stimulation of a muscle, for all stimuli which are applied to a muscle, must at the same time act on the nerve, for the muscle is the proper end-organ of a motor nerve.

Neuro-Muscular Cells.—Even in the lower animals—*e.g.*, Hydra (Kleinenberg), and Medusa (Eimer)—there are uni-cellular structures called "*neuro-muscular cells*," in which the nervous and muscular substances are represented in the same cell. [The outer part of these cells is adapted for the action of stimuli, and corresponds to the nervous receptive organ, while the inner deeper part is contractile, and is the representative of the muscular part.]

Muscular Stimuli.—Various stimuli cause a muscle to contract, either by acting upon its motor nerve (*indirect*) or upon the muscular substance itself (*direct*) (§ 324).

1. Under ordinary circumstances, the **normal stimulus** causing a muscle to contract is the *nerve impulse* which passes along a nerve, but its exact nature is unknown, *e.g.*, in voluntary movements, automatic motor movements, and reflex acts.

2. **Chemical Stimuli.**—All chemical substances, which alter the chemical composition of a muscle with sufficient rapidity, act as *muscular stimuli*. According to Kühne, mineral acids (HCl 0·1 per cent., acetic and oxalic acids, the salts of iron, zinc, copper, silver, and lead), bile (Budge), all act in weak solutions as muscular stimuli; while they act upon the motor nerve only when they are more concentrated. Lactic acid and glycerin, when concentrated, excite only (?) the nerve; when dilute, only the muscle. Neutral alkaline salts act equally upon nerve and muscle, alcohol and ether act on both very feebly. When water is injected into the blood-vessels, it causes fibrillar muscular contractions (*v.* Wittich), while a 0·6 per cent. solution of NaCl may be passed through a muscle for days without causing contraction (Kölliker, O. Nasse). Acids, alkalies, and extract of flesh diminish the muscular excitability, while the muscular stimuli, in small doses, increase it (Ranke).

Gases and *vapours* stimulate muscle; they cause either a simple contraction (*e.g.*, HCl) or at once, permanent contraction or contracture (*e.g.*, Cl). Long exposure to the gas causes rigidity. The vapour of bisulphide of carbon stimulates only the *nerves*, while most vapours (*e.g.*, HCl) kill without exciting them (Kühne and Jani).

Method.—In making experiments upon the chemical stimulation of muscle, it is unadvisable to dip the transverse section of the muscle into the solution of the chemical reagent (Hering). The chemical stimulus ought to be applied in solution to a limited portion of the uninjured surface of the muscle; after a few seconds, we obtain a contraction or fibrillar twitchings of the superficial muscular layers (Hering). If the sartorius of a curarised frog be dipped into a solution composed of 5 grammes NaCl, 2 grammes alkaline sodium phosphate, and 0.5 gramme sodium carbonate in 1 litre of water, at 10°C., the muscle contracts *rhythmically*, and may do so for several days (Biedermann). This recalls the rhythmical contraction of the heart (Biedermann).

3. **Thermal Stimuli.**—If an excised frog's muscle be rapidly heated towards 28°C., a gradually increasing contraction occurs, which, at 30°C., is more pronounced, reaching its maximum at 45°C. (Eckhard, Schumlewitsch). If the temperature be raised, "*heat-stiffening*" rapidly ensues. The *smooth* muscles of warm-blooded animals also contract when they are warmed, but those of cold-blooded animals are elongated by heat (Grünhagen, Samkowy). If a frog's muscle be cooled to 0°, it is very excitable to mechanical stimuli (Grünhagen); it is even excited by a temperature under 0° (Eckhard).

Cl. Bernard observed that the muscles of animals artificially cooled (§ 225, p. 456) remained excitable many hours after death. Heat causes the excitability to disappear rapidly, but it increases it temporarily.

4. **Mechanical Stimuli.**—Every kind of sudden mechanical stimulus, provided it be applied with sufficient rapidity to a muscle (and also to a nerve), causes a *contraction*. If stimuli of sufficient intensity be repeated with sufficient rapidity, *tetanus* is produced. *Strong local* stimulation causes a weal-like, long-continued contraction at the part stimulated (§ 297, 3, a).

5. **Electrical Stimuli** will be referred to when treating of the stimulation of nerve (§ 324).

Curara.—The arrow-poison of the Indians of South America consists of the dried juice of the root of *Strychnos crevauxi*; when injected into the blood or subcutaneously, it causes at first, paralysis of the intramuscular *ends of the motor nerves* (p. 635), while the muscles themselves remain excitable; the sensory nerves, the central nervous system, viscera, heart, intestine, and the blood-vessels are not affected (Cl. Bernard, Kölliker).

Actions.—In warm-blooded animals, death takes place by asphyxia, owing to paralysis of the diaphragm, but of course there are no spasms. In frogs, where the skin is the most important respiratory organ, if a suitable dose be injected under the skin, the animal may remain motionless for days and yet recover, the poison being eliminated by the urine (Kühne, Bidder). If the dose be larger, the inhibitory fibres of the *vagus* may be paralysed. In electrical fishes, the sensory nerves concerned with the electrical discharge are paralysed (Marey). In frogs, the lymph-

hearts are paralysed. A dose sufficient to kill a frog, when injected under its skin, will not do so if administered by the mouth, because the poison seems to be eliminated as rapidly by the kidneys as it is absorbed from the gastric mucous membrane. For the same reason the flesh of an animal killed by curara is not poisonous when eaten. If, however, the ureters be tied, the poison collects in the blood, and poisoning takes place (L. Hermann). Large doses, however, poison uninjured animals even when given by the mouth. The nerves (Funke) and muscles (Valentin) of poisoned animals exhibit considerable electro-motive force.

Atropin appears to be a specific poison for smooth muscular tissue, but different muscles are differently affected (Szpilmann, Luchsinger).

Excitability after Section of the Motor Nerves.—After section of the motor nerve of a muscle, the excitability undergoes remarkable changes; after 3–4 days the excitability of the paralysed muscle is diminished, both for direct and indirect (*i.e.*, through the nerve) stimuli; this condition is followed by a stage, during which a constant current is more active than normal, while induction currents are scarcely or not at all effective (§ 339, I). The excitability for mechanical stimuli is also increased. The increased excitability occurs until about the 7th week; gradually it diminishes until it is abolished towards the 6th–7th month. Fatty degeneration begins in the second week after section of the motor nerve, and goes on until there is complete muscular atrophy. Immediately after section of the sciatic nerve, Schmulewitsch found that the excitability of the muscles supplied by it was increased.

297. Changes in a Muscle during Contraction.

I. Macroscopic Phenomena.—1. When a muscle contracts, it becomes shorter and at the same time thicker (Erasistratus, B.C. 30±).

The degree of contraction, which in very excitable frogs may be 65–85 per cent. (72 per cent. mean) of the total length of the muscle, depends upon various conditions: (*a*) Up to a certain point, increasing the *strength of the stimulus* causes a greater degree of contraction; (*b*) as the *muscular fatigue* increases, *i.e.*, after continued, vigorous exertion, the stimulus remaining the same, the extent of contraction is diminished; (*c*) the *temperature of the surroundings* has a certain effect. The extent of the contraction is increased in a frog's muscle—the strength of stimulus and degree of fatigue remaining the same—when it is heated to 33°C. If the temperature be increased above this point, the degree of contraction is diminished (Schmulewitsch).

2. The volume of a contracted muscle is slightly diminished (Swammerdam † 1680). Hence, the *specific gravity* of a contracted muscle is slightly increased, the ratio to the non-contracted muscle being 1062 : 1061 (Valentin); the diminution in volume is however only $\frac{1}{1370}$.

Methods.—(*a*) Erman placed portions of the body of a live eel in a glass vessel filled with an indifferent fluid. A narrow tube communicated with the glass vessel, and the fluid rose in the tube to a certain level. As soon as the muscles of the eel were caused to contract, the fluid in the index-tube sank.

(b) Landois demonstrates the decrease in volume by means of a manometric flame. The cylindrical vessel containing the muscle is provided with two electrodes fixed into it in an air-tight manner. The interior of the vessel communicates with the gas supply, while there is a small narrow exit-tube for the gas which is lighted. Every time the muscle contracts, the flame diminishes. The same experiment may be performed with a contracting heart.

3. **Total and Partial Contraction.**—Normally, all stimuli applied to a muscle or its motor nerve cause contraction in all its muscular fibres. Thus, the muscle conducts the state of excitement to all its parts. Under certain circumstances, however, this is not the case, viz.:—(a) when the muscle is greatly fatigued, or when it is about to die, a *violent mechanical stimulus*, as a vigorous tap with the finger or a percussion hammer (and also chemical or electrical stimuli), cause a localised contraction of the muscular fibres. This is Schiff's "*ideo-muscular contraction*." The same phenomenon is exhibited by the muscles of a healthy man, when the blunt edge of an instrument is drawn transversely over the direction of the muscular fibres (Mühlhauser, Auerbach); (b) under certain, as yet but imperfectly known conditions, a muscle exhibits so-called *fibrillar contractions*—*i.e.*, short contractions occur alternately in different bundles of muscular fibres. This is the case in the muscles of the tongue, after section of the hypoglossal nerve (Schiff); and in the muscles of the face, after section of the facial nerve.

Cause of Fibrillar Contraction.—According to Bleuler and Lehmann, section of the hypoglossal nerve in rabbits is followed by fibrillar contractions after 60–80 hours; these contractions may continue for months, even when the divided nerve has healed and is stimulated above the cicatrix so as to produce movements in the corresponding half of the tongue. Stimulation of the lingual nerve increases the fibrillar contractions or arrests them. This nerve contains vaso-dilator fibres derived from the chorda tympani. Schiff is of opinion that the increased blood-stream through the organ is the cause of the contractions. Sig. Mayer found that, by compressing the carotids and subclavian, and again removing the pressure so as to permit free circulation, the muscles of the face contracted. Section of the motor nerves of the face did not abolish the phenomenon, but compression of the arteries did. The cause of the phenomenon, therefore, seems to lie within the muscles themselves. This phenomenon may be compared to the *paralytic secretion* of saliva, and pancreatic juice which follows section of all the nerves going to these glands (p. 288, p. 345). Similar fibrillar contractions occur in man under pathological conditions, but they may also occur without any signs of pathological disturbance. [Fibrillar contractions, due to a central cause, occur in monkeys after excision of the thyroid gland (V. Horsley).]

II. Microscopic Phenomena.—1. Single muscular *fibrillæ* exhibit the same phenomena as an entire muscle, in that they contract and become thicker. 2. There is great difficulty in observing the changes that occur in the individual parts of a muscular fibre during the act of contraction. This much is certain that, the muscular elements become

shorter and broader during contraction. Thus, it is evident that the transverse striæ must appear to approach nearer to each other (Bowman, 1840). 3. There is great difference of opinion as to the behaviour of the doubly refractive (anisotropic) and the singly refractive media.

Fig. 240, 1, on the left represents, according to Engelmann, a passive muscular element—from *c* to *d* is the doubly refractive, contractile substance, with the median disc, *a*, *b*, in it; *h* and *g* are the lateral discs. Besides these, in each of the singly refractive discs there is a clear disc—"secondary disc"—*f* and *e*, which is only slightly doubly refractive. This occurs only in the muscles of insects. Fig. 1, on the right, shows the same element in polarised light, whereby the middle area of the element, as far as the contractile substance proper extends, is, owing to its double refraction, bright; while the other part of the muscular element, owing to its being singly refractive, is black. Fig. 240, 2, is the transition stage, and 3 the proper stage of contraction of the muscular element. In both cases the figures on the left are viewed in ordinary light, and on the right, in polarised light.

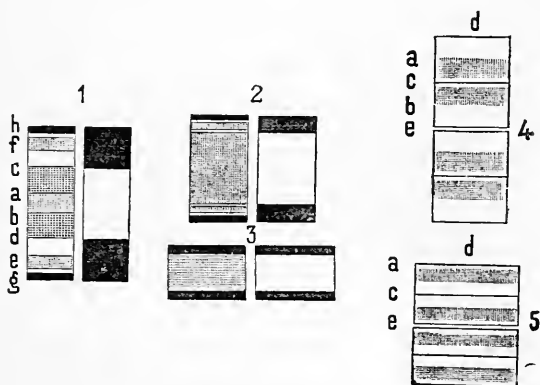

Fig. 240.

The microscopic appearances during a muscular contraction in the individual elements of the fibrillæ—1, 2, 3, after Engelmann; 4, 5, after Merkel.

Engelmann's View.—According to Engelmann, during contraction (Fig. 240, 3), the singly refractive disc becomes as a whole more refractive, the doubly refractive less so. Consequently, a fibre at a certain degree of contraction (2), when viewed in *ordinary* light, may appear homogeneous and but slightly striped transversely—the *homogeneous or transition stage*.

During a greater degree of contraction (3), very dark transverse stripes reappear, corresponding to the singly refractive discs. At every stage of the contraction, as well as in the transition stage, the singly and doubly refractive discs are sharply defined, and are recognised by the polari-

scope, as regular alternating layers (in 1, 2, and 3 on the right). These do not change places during the contraction. The height of both discs is diminished during contraction, but the singly refractive do so more rapidly than the doubly refractive discs. The total volume of each element does not undergo any appreciable alteration in volume during the contraction. Hence, the doubly refractive discs increase in volume at the expense of the singly refractive. From this it is concluded that, during the contraction, fluid passes from the singly refractive into the doubly refractive discs; the former shrink, the latter swell.

Merkel's view is partially different. In Fig. 240, 4, are two muscular elements at rest; in (5), two in a state of contraction, after Merkel. The grey punctuated areas are the doubly refractive substance, *c*, the median disc. According to Merkel, during contraction, the *dark* substance lying in the middle of the element changes its position—either in part or as a whole; it leaves the middle of the element (the two surfaces of Hensen's median discs, 4, *c*), and places itself at the lateral discs, 5, at *e* and *d*, while the clear substance leaves the lateral disc, 4, *e* and *d*, and applies itself to both surfaces of the median disc, 5, *c*. The clear substance of the isotropous discs is fluid, and plays a more passive rôle; during contraction, it is in part absorbed by the dark substance, which thus swells up. This mutual exchange of place of the substances is accompanied by an intermediate "*stage of dissolution*," in which the whole contents of the element appear equally homogeneous (Montgomery), in which, therefore, the fluid, singly refractive substance has uniformly penetrated the doubly refractive substance. At this moment only the lateral discs are still visible.

[If a living portion of an insect's muscle be examined in its own juice, contraction waves may be seen to pass over the fibres. When a contraction wave passes over part of the fibres, the discs become *shorter* and *broad*; at the same time, in the fully contracted part, the dim disc appears lighter than the centre of the light disc. There is said to be a "*reversal of the stripes*" from what obtains in a passive muscle. Before this stage is reached there is an intermediate stage, where the two bands are almost uniform in appearance.]

Methods.—These phenomena are best observed by "fixing" the different stages of rest or contraction, by suddenly plunging the muscular fibrillæ of insects' muscles into alcohol or osmic acid, which coagulates the muscle-substance. The actual contraction may be observed under the microscope, in the transparent parts of the larvæ of insects.

Spectrum.—A thin muscle—*e.g.*, the sartorius of the frog—when placed directly behind a narrow slit running at right angles to the course of the fibres, yields a *diffraction-spectrum*. When the muscle contracts, as by mechanical stimulation, the spectrum broadens—a proof that the interspaces of the transverse stripes become narrower (Ranvier).

298. Muscular Contraction.

Myography—Simple Contraction—Tetanus.

Methods.—In order to determine the duration of each phase of a muscular contraction, myographs of various forms are used.

v. Helmholtz's Myograph.—Helmholtz constructed a myograph of the form shown in Fig. 241. A muscle, M—say the gastrocnemius of a frog attached to the femur—is fixed by the femur in a clamp, K, the lower free-end of the muscle being attached to a movable lever carrying a scale-pan and weight, W, the weight being varied at pleasure. When the muscle contracts, necessarily it must raise the lever. To the free-end of the lever is attached a movable style, F, capable of adjustment, and which, when properly adjusted, inscribes its movements on a revolving cylinder caused to rotate at a uniform rate by means of clock-work (Fig. 73). The cylinder is covered with enamelled paper smoked in the flame of a turpentine lamp. When the muscle contracts, it inscribes a curve, the "muscle-curve" or "myogram." The *abscissa* indicates the *duration* of the contraction, but of course the rate at which the cylinder is moving must be known. The *ordinates* represent the extent of contraction at any particular part of the curve.

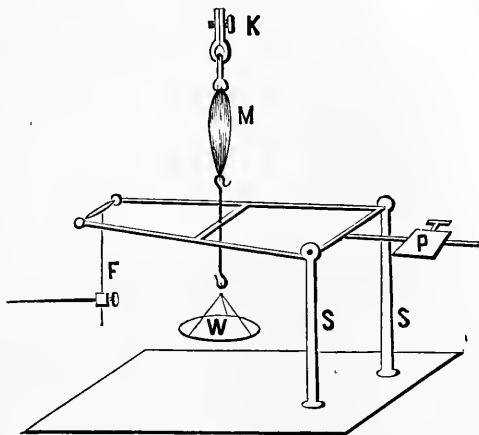

Fig. 241.

Scheme of v. Helmholtz's myograph—M, muscle fixed in a clamp, K; F, writing style; P, weight or counterpoise for the lever; W, scale-pan for weights; S, S, supports for the lever.

The muscle-curve may be inscribed upon a smoked glass plate attached to one limb of a vibrating tuning-fork (Fig. 67—Hensen and Klunder). Such a curve registers the time-units in all its parts. Suppose each vibration of the tuning-fork = 0.01613 second, then the duration of any part of such a curve is obtained by counting the number of vibrations and multiplying by 0.01613 second.

[Pendulum Myograph.—A. Fick invented this instrument. In its improved form by v. Helmholtz (Fig. 242), it is shown both from the front and the side. A board fixed to the wall carries a heavy iron pendulum, P, whose axis, A, A, moves on friction rollers. At the lower swinging end are two glass plates, G and G', fixed to a bearer, T. The plates can be adjusted by means of the screw, s, so that several curves can be written one above the other. The plate, G', on the posterior surface is

merely a compensator, so that when G is elevated G' is lowered, and thus the duration of the oscillation is not altered. The spring catches, H, H , which can be turned inwards or outwards, are used to fix the pendulum by the teeth, a, a , when it is drawn to one side. The pendulum is

drawn to one side and fixed, a , in H , so that when H is pulled down, it is liberated and swings to the other side, where it is caught by H at the opposite side. In the improved form, the catches, H , are made to slide along a rod like the arc of a circle, so that the length of the swing can be varied. As the pendulum swings from the one side to the other, the projecting points, a, a , knock over the contact key, b , and the current is opened and a shock transmitted to the muscle. The writing-lever to which the muscle is attached is usually a heavy one, and a style writes upon the smoked surface of the glass. Of course, when the pendulum swings, it moves with

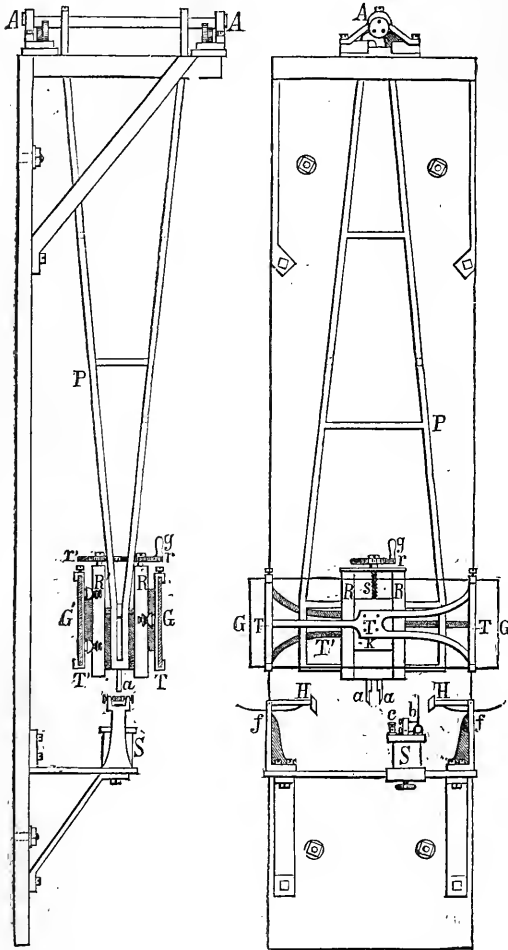

Fig. 242.

Fick's pendulum myograph, as improved by v. Helmholtz ($\frac{1}{2}$ natural size), side and front view (see text).

unequal velocities at different parts of its course.]

[When using the pendulum myograph to study a muscular contraction, arrange it as in Fig. 243. The frog's muscle is attached to a writing-lever which is very like the lever in Fig. 241, while the style inscribes its movements on the blackened plate. The pendulum is fixed in the

catch, C, as shown in the figure; the key, K', is closed and placed in the primary circuit, while two wires from the secondary coil of an induction machine are attached to the muscle. When the pendulum swings, the projecting tooth, S, knocks over the contact at K', and breaks the primary circuit, when a shock is instantly transmitted through the muscle. Before stimulating, allow the pendulum to swing to obtain an abscissa. The time is recorded by a vibrating tuning-fork, of known rate of vibration, connected with a Depré's electric chronograph. Depré's chronograph is merely a small electro-magnet with a fine writing-style attached to the magnet, which vibrates when it is introduced in an electrical circuit, in which is placed a vibrating tuning-fork. The signal vibrates just as often as the tuning-fork.]

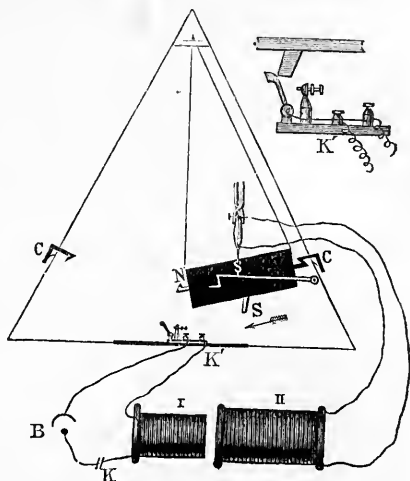

Fig. 243.

Scheme of the arrangement of the pendulum myograph—B, battery; I, primary, II, secondary spiral of the induction machine; S', tooth; K', key; C, C, catches; K' in the corner, scheme of K'; K, key in primary circuit.

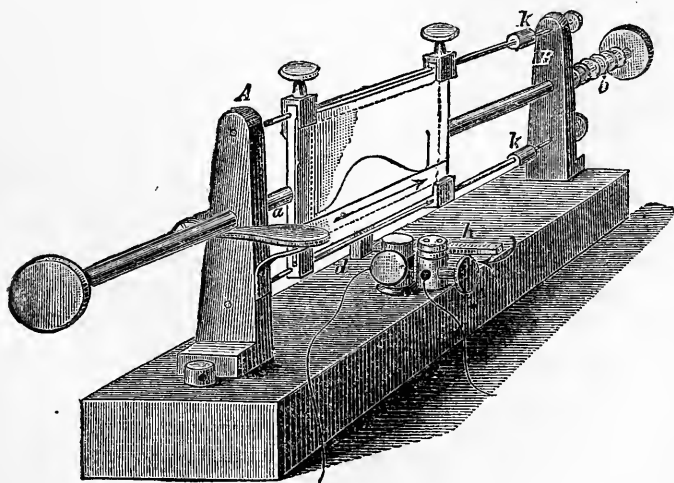

Fig. 244.

[Spring Myograph.—This is used by du Bois-Reymond chiefly for demonstrations (Fig. 244). It consists of a glass plate fixed in a frame, and moving

on two polished steel wires, stretched between the supports A and B. At *b* is a spring, which when it is compressed between the upright, B, and the knob, *b*, drives the glass plate from B to A. As the plate moves from one side to the other, a small tooth *d*, on its under surface opens the key, *h*, and thus a shock is transmitted to the muscle. The arrangement otherwise is the same as for the pendulum myograph. The smoked glass plate is liberated by the projecting finger plate attached to the upright, A.]

[Simple Myograph of Marey.—The gastrocnemius is attached to a horizontal lever which inscribes its movements on a revolving cylinder. This form of myograph when provided with two levers is very useful for comparing the action of a poison on one limb, the other being unpoisoned.]

[Pfüger's stationary form, which is simply a Helmholtz's myograph (Fig. 241) arranged to record its movements on a stationary glass plate, so that the muscle merely makes a vertical line or ordinate instead of a curve; it thus merely indicates the height or extent of the contraction, not its duration.]

A rapidly rotating disc was used by Valentin and Rosenthal for registering the muscle-curve, while Harless used a plate which was allowed to fall rapidly, the so-called "Fall-myograph." In all these experiments it is necessary to indicate at the same time the moment of stimulation.

As the lever of the myograph has vibrations peculiar to itself, which complicate the muscle-curve, the traction of the muscle may be advantageously allowed to act on a *spring*.

Contraction Curve of Human Muscle.—In man, another principle is adopted, viz., to measure the increase in *thickness* during the contraction, either by means of a lever or a compressible tambour (Marey), such as is used in Brondegeest's pansphygmograph (p. 132). [The *thickening* of the adductor muscles of the thumb may be registered by means of Marey's *pince myographique*.]

I. Simple Contraction.—If a *single shock* or *stimulus of momentary duration* be applied to a muscle, a "*simple muscular contraction*" [or shortly, a *contraction*, a *twitch*—Burdon Sanderson] is the result, *i.e.*, the muscle rapidly shortens and quickly returns again to its original, relaxed condition.

Myogram or Muscle-Curve.—Suppose a single stimulus be applied to a muscle attached to a light writing-lever, which is not "overweighted" with any weight attached to it, then, when the muscle contracts, the following events take place:—

- [1. A period or stadium of latent stimulation ;
2. A period of increasing energy or contraction ;
3. A period of decreasing energy or more rapid relaxation ;
4. A period of slow relaxation or the stage of elastic after-vibration.]

The muscle-curve proper is composed of 2, 3, and 4.

1. The latent period (Fig. 245, *a, b*—*v.* Helmholtz) consists in this, that the muscle does not begin to contract precisely at the moment the stimulus is applied to it, but the contraction occurs somewhat later, *i.e.*, a short but measurable interval elapses between the application of a

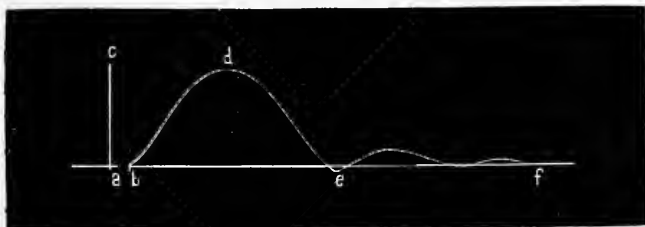

Fig. 245.

Muscle-curve produced by the application of a single induction shock to a muscle—*a-f*, abscissa; *a-c*, ordinate; *ab*, period of latent stimulation; *bd*, period of increasing energy; *de*, period of decreasing energy; *ef*, elastic after-vibrations.

momentary stimulus and the contraction. If the entire muscle be stimulated by a momentary stimulus, *e.g.*, a single opening induction shock, the duration of the latent period is about 0.01 second. In smooth muscle, the latent period may last for several seconds.

In *man*, the latent period varies between 0.004 and 0.01 second. If the experiment be so arranged that the muscle can contract as soon as the stimulus is applied to it, *i.e.*, before time is lost in making the muscle tense; or, to put it otherwise, if the muscle has not to "take in slack," as it were, the latent period may fall to 0.004 second (Gad). If the muscle be still attached to the body, protected as much as possible from external influences and properly supplied with blood, the latent period may be reduced to 0.003.

[The latent period is shortened by an increased strength of the stimulus and by heat; while fatigue, cooling, and increasing weight lengthen it (Lauterbach, Mendelsohn, Yeo, Cash). The latent period of an opening contraction may be even as much as 0.04 second longer than that of a closing contraction.]

[Although no change be visible in a muscle during the latent period, nevertheless we have proof that some change does take place within the muscle-substance, for we know that the electrical current of the muscle is diminished during this period, or we have what is known as the *negative variation* of the muscle-current (Bernstein—§ 333).]

[In measuring the myogram, all that is required is to know the moment at which the stimulus was applied, and to note when the curve begins to leave the base line or abscissa. Raise a vertical line from each of these points, and the interval between these lines, as measured by the chronograph, indicates the time.]

2. The contraction or stage of increasing energy, *i.e.*, from the moment the muscle begins to shorten until it reaches its greatest degree of contraction (*b d*). At first the muscle contracts slowly, then more rapidly, and again more slowly, so that the ascending limb of the curve has somewhat the form of an *f*. This stage lasts 0.03–0.04 second.

It is shorter when the contraction is shorter (weak stimulus), and the less the weight the muscle has to lift. It also varies with the excitability of the muscle, being shorter in a fresh, non-fatigued muscle.

3. **Rapid Elongation or Stage of Decreasing Energy.**—After the muscle has contracted up to its maximum for any particular stimulus, it begins to relax—at first slowly, then rapidly—and lastly more slowly, so that an inverse form of an f is obtained ($d e$). This stage is usually of shorter duration than 2. The duration varies with the strength of the stimulus, being shorter than 2 with a weak stimulus, and longer with a strong stimulus. It also depends upon the extent to which the muscle is loaded during contraction.

4. The fourth stage has received various names—**stage of elastic after-vibration** [*residual contraction* or *contraction remainder* (Hermann)]. The after-vibrations ($e f$), which disappear gradually, depend upon the elasticity of the muscle. The duration of this stage is longest with a powerful contraction, and when the weight attached to the muscle is light].

If the stimulus be applied to the motor nerve instead of to the muscle itself, the contraction is greater (Pfüger), and lasts longer (Wundt) the nearer to the spinal cord the stimulus is applied to the nerve.

[**Method—Faradic Shocks.**—The time-relations of a muscular contraction may be studied by means of the following arrangement:—

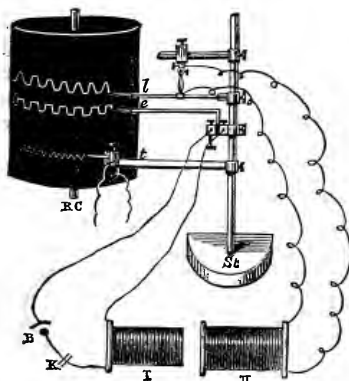

Fig. 246.

Arrangement for calculating the time-relations during contraction of a muscle produced by a faradic shock—B, battery; K, key in primary circuit; I, primary, II, secondary spiral; l , muscle-lever; e , electro-magnet in primary circuit; t , electric signal; St , support; R C, revolving cylinder (after Rutherford).

Attach a frog's gastrocnemius to a lever, as in Fig. 246, and through the frog's muscle place two wires from the secondary coil of an induction machine. A scale-pan, into which weights may be placed, especially if it is one of the light levers used by Marey. On the same support adjust an electro-magnet with a writing-style in the primary circuit, and in this circuit also place a key (K) to open and break the current. Fix also a Depré's chronograph to the same support, and make it vibrate by connecting it in circuit with a tuning-fork of known rate of vibration, and driven by a galvanic battery. See that the points of all three levers write exactly over each

other on the revolving cylinder. The upper lever registers the contraction, the electro-magnet the moment the stimulus is applied to the muscle, and the electrical chronograph the time.]

Overweighted Muscles.—The foregoing remarks apply to curves obtained by a *light* lever connected with the muscle. If the muscle-lever be “*overweighted*,” or *overloaded*—*i.e.*, if the lever be loaded, so that when the muscle contracts it has to lift these weights, the course of the curve is varied according to the weight to be lifted. It is necessary, however, to support the lever in the intervals when the muscle is at rest. As the weights are increased, the occurrence of the contraction is delayed. This is due to the fact that the muscle, at the moment of stimulation, must accumulate as much energy as is necessary to lift the weight. The greater the weight the longer is the time before it is raised. Lastly, the muscle may be so “loaded” or “overloaded” that it cannot contract at all—this is the limit of the muscular or mechanical energy of the muscle (*v.* Helmholtz).

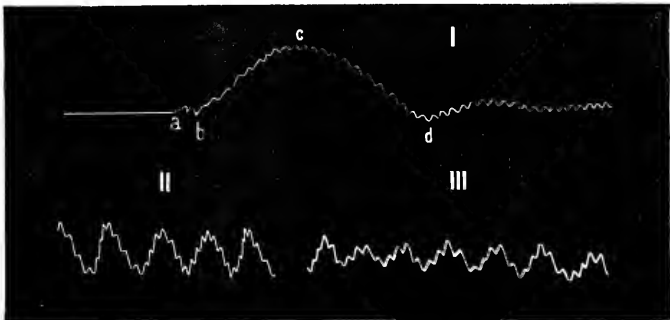

Fig. 247.

- I, Contraction of a *fatigued* frog's muscle writing its contraction on a vibrating plate attached to a tuning-fork (see Fig. 67, p. 153). Each vibration = 0.01613 second; *ab*, = latent period; *bc*, stage of increasing energy; *cd*, of decreasing energy—II, The most rapid writing movements of the right hand inscribed on a vibrating plate—III, The most rapid trembling tetanic movements of the right fore-arm inscribed on the same plate.

Fatigue.—If a muscle be caused to contract so frequently that it becomes “*fatigued*,” the latent period is longer, the curve is not so



Fig. 248.

Effect on a muscle of closing and opening a constant current—
S, closing; O, opening shock (after Wundt).

high, because the muscular contraction is less, and the abscissa is longer—

i.e., the contraction is *slower* and lasts longer (Fig. 247, I). *Cooling* a muscle has the same effect (v. Helmholtz and others). Soltmann finds that the fresh muscles of *new-born* animals behave in a similar manner. The myogram has a flat apex and considerable elongation in the descending limb of the curve.

Constant Current.—If the *motor nerve* of a muscle be stimulated by a closing or opening shock of a *constant current*, the resulting muscular contraction corresponds exactly to that already described. If, however, the current be closed or opened with the muscle itself directly in the circuit during the closing shock, there is a certain degree of contraction which lasts for a time, so that the curve assumes the form of Fig. 248, where S represents the moment of closing or making the current, and \bar{O} the moment of opening or breaking it (Wundt—compare § 336, D).

The investigations of Cash and Kronecker show that, individual muscles have a special form of muscle-curve; the omohyoid of the tortoise contracts more rapidly than the pectoralis. Similar differences occur in the muscles of frogs and mammals. The flexors of the frog contract more rapidly than the extensors. Sometimes within one and the same muscle there are “red” (rich in glycogen) and “pale” fibres (§ 292). The red fibres contract more slowly, are less excitable, and less easily fatigued (Grützner).

Poisons.—Very small doses of *curara* or *quinine* (Schtschepotjew) increase the height of the contraction (excited by stimulation of the motor nerve), while larger doses diminish it, and finally abolish it altogether. *Guanidin* has a similar action in large doses, but the maximum of contraction lasts for a longer time. Suitable doses of *veratrin* also increase the contractions, but the stage of relaxation is greatly lengthened (Rossbach and Clostermeyer). *Veratrin*, *antiarin*, and *digitalin*, in *large* doses act upon the sarcois substance in such a way that, the contractions become very prolonged, not unlike a condition of prolonged tetanus (Harless, 1862). The latent period of muscles poisoned with *veratrin* and *strychnin* is shortened at first, and afterwards lengthened. The gastrocnemius of a frog supplied by blood containing soda contracts more rapidly (Grützner).

[**Veratrin.**—If a frog be poisoned with *veratrin*, and then be made to spring, it does so rapidly, but when it alights again the hind legs are extended, and they are only drawn up after a time. Thus, rapid and powerful contraction, with slow and prolonged relaxation, are the character of the movements. In a muscle poisoned with *veratrin*, the ascent is quick enough, but it remains contracted for a long time, so that this condition has been called “contracture.” A single stimulation may cause a contraction lasting 5 to 15 seconds, according to circumstances. Brunton and Cash find, that cold has a marked effect on the action of *veratrin*—in fact, its effect may be permanently destroyed by exposure to extremes of heat or cold. The muscle-curve of a brainless frog cooled artificially, and then poisoned by *veratrin*, occasionally gives no indications of the action of the poison until its temperature is raised, and this is not due to non-absorption of the poison. Cold, therefore, abolishes or lessens the contracture peculiar to the *veratrin* curve.]

Smooth Muscles.—The muscle-curve of smooth or non-striated muscles is similar to that of the striated muscles, but the duration of the contraction is visibly much longer, and there are other points of difference. Some muscles stand midway between these two, at least

as far as the duration of their contractions are concerned. The "red" muscles of rabbits (p. 653), the muscles of the tortoise, the adductors of the common mussel, and the heart (p. 109), all react in a similar manner. The muscles of flying insects contract extremely rapidly, more than 100 times per second (H. Landois).

Contraction Remainder.—A contracted muscle assumes its original length only when it is extended by sufficient traction (*e.g.*, by means of a weight—Kühne). Otherwise, the muscle may remain partially shortened for a long time (*v.* Helmholtz, Schiff). This condition has been called "*contracture*" (Tiegel), or, better, *contraction remainder* (Hermann). This condition is most marked in muscles that have been previously subjected to strong, direct stimulation, and are greatly fatigued (Tiegel), which are distinctly acid, and ready to pass into rigor mortis, or in muscles excised from animals poisoned with veratrin (*v.* Bezold).

Rapidity of Muscular Contraction.—In *man*, single muscular movements can be executed with great rapidity. The time-relations of such movements are most readily ascertained by inscribing the movements upon a smoked glass plate attached to a tuning-fork. Fig. 247, II, represents the most rapid *voluntary* movements that Landois could execute, as, *e.g.*, in writing the letters *n, n*, and every contraction is equal to about 3.5 vibrations (1 vibration = 0.01613 second) = 0.0564 second. In III, the right arm was tetanised, in which case 2–2.5 vibrations occur = 0.0323 to 0.0403 second.

Pathological.—In secondary degeneration of the spinal cord after apoplexy, atrophic muscular ankylosis of the limbs (Edinger), muscular atrophy, progressive ataxia, and paralysis agitans of long standing, the latent period is *lengthened*; while it is *shortened* in the contracture of senile chorea and spastic tabes (Mendelsohn). The whole curve is lengthened in jaundice and diabetes (Edinger).

In cerebral hemiplegia, during the stage of contracture, the muscle-curve resembles the curve of a muscle poisoned with veratrin, and the same is the case in spastic spinal paralysis and amyotrophic lateral sclerosis; in pseudo-hypertrophy of the muscles, the ascent is short and the descent very elongated. In muscular atrophy, after cerebral hemiplegia and tabes, the latent period increases, while the height of the curve diminishes. In chorea the curve is short. (For the *Reaction of Degeneration*, see § 339.)

In rare cases in *man*, it has been observed that the execution of spontaneous movements results in a very prolonged contraction (*Thomson's disease*).

II. Action of Two Successive Stimuli.—Let two momentary stimuli be applied successively to a muscle:—(A.) If *each stimulus* or shock be of itself sufficient to cause a *maximal contraction* (*i.e.*, the greatest possible contraction which the muscle can accomplish), then the effect will vary according to the *time* which elapses between the application of the two stimuli. (a.) If the second stimulus is applied to the muscle *after* the relaxation of the muscle following upon the first stimulus, we obtain merely two maximal contractions. (b.) If, however, the second stimulus

be applied to the muscle *during* the time that the effect of the first is present, *i.e.*, while the muscle is in the phase of contraction or of relaxation; in this case, the second stimulus causes a new maximal contraction, according to the time of the particular phase of the contraction. (c.) When, lastly, the second stimulus follows the first so rapidly that both occur during the latent period, we obtain only *one* maximal contraction (v. Helmholtz).

(B.) If the stimuli be not maximal, but only such as cause a *medium* or *sub-maximal* contraction, the effects of both stimuli are superposed, or there is a *summation* of the contractions (Fig. 249). It is of no consequence at what particular phase of the primary contraction the second shock is applied. In all cases, the second stimulus causes a contraction, just as if the phase of contraction caused by the first shock was the natural, passive form of the muscle, *i.e.*, the new contraction (*b, c*) starts from that point as from an abscissa (Fig. 249, I, *b*). Thus, under favourable conditions, the contraction may be twice as great as that caused by the first stimulus. The most favourable time for the application of the second stimulus is $\frac{1}{2}$ th second after the application of the first (Sewall). The effects of both stimuli are obtained even when the second stimulus is applied during the latent period (v. Helmholtz).

III. Tetanus—Rapidly Occurring Stimuli.—If stimuli, following each other with medium rapidity, be applied to a muscle, the muscle has not sufficient time to elongate or relax in the intervals of stimulation. Therefore, according to the rapidity of the successive stimuli, it remains in a condition of continued vibratory contraction, or in a state of *tetanus*.

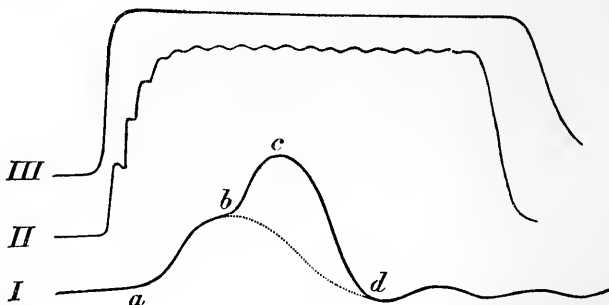

Fig. 249.

I, two successive sub-maximal contractions; II, successive contractions produced by stimulating a muscle with 12 induction shocks per second; III, curve produced with very rapid induction shocks.

Tetanus is, however, not a continuous uniform condition of contraction, but it is a discontinuous condition or form of the muscle, depending upon the *summation* or accumulation of contractions. If the stimuli are

applied with moderate rapidity, the individual contractions appear in the curve (Fig. 249 II); if they occur rapidly, and thus become superposed and fused, the curve appears continuous and unbroken by elevations and depressions (Fig. 249, III).

As a fatigued muscle contracts slowly, it is evident that such a muscle will become tetanic by a smaller number of stimuli per second than will suffice for a fresh muscle (Marey, Fick, Minot). All muscular movements of *long duration* occurring in our bodies are probably tetanic in their nature (Ed. Weber).

The *tetanic contractions* which occur normally in an *intact body*, are proved to consist of a series of successive contractions, because they can give rise to *secondary tetanus* (§ 332), which may also be caused by muscles thrown into tetanus by strychnin poisoning (Lovèn).

[Baxt found that, the simplest possible voluntary contraction—*e.g.*, striking with the index finger, occupies on an average nearly twice as long time as a similar movement discharged by a single induction shock.]

A continued **voluntary contraction** in man, consists of a series of single contractions rapidly following each other. Every such movement, on being carefully analysed, consists of intermittent vibrations, which reach their maximum when a person shivers. The requisite degree of shortening is obtained by the summation of single stimuli applied to the slowly contracting muscle.

The muscle-sound cannot be regarded as a certain proof of the oscillatory movement in tetanus, [as Helmholtz has shown that this sound coincides with the resonance sound of the ear (Hering and Friedrich).]

If a muscle be connected with a **telephone**, whose wires are brought into connection with two needles, one placed in the tendon, and the other in the substance of the muscle, we hear a *sound* when the muscle is thrown into tetanus, which proves that periodic vibratory processes—*i.e.*, successive contractions, occur in the muscle (Bernstein and Schönlein).

The sound is most distinct when the tetanising Neef's hammer of an induction machine vibrates about 50 times per second (Wedenskii and Kronecker).

The **number of stimuli** requisite to produce tetanus varies in different animals, and in different muscles of the same animal. About 15 stimuli per second are required to produce tetanus in the muscles of the *frog* (hyoglossus only 10, gastrocnemius 27); very feeble stimuli (more than 20 per second) cause tetanus (Kronecker); the muscles of the *tortoise* become tetanic with 2-3 shocks per second; the *red* muscles of the *rabbit* by 10, the *pale* by over 20 (Kronecker and Stirling); muscles of birds not even with 70 (Marey); muscles of insects 330-340 per second (Marey, Landois). Tetanic stimulation of the muscles of the crayfish (*astacus*), and also in *hydrophilus*, may cause *rhythmical* contractions (Riche), or rhythmically interrupted tetanus (Schönlein).

[The red and pale muscles of a rabbit, as already shown, differ structurally, and also in regard to their blood supply (p. 619). They also differ physiologically. When both muscles are caused to contract, by stimulating the sciatic nerve with a single induction shock, the curves obtained are shown in Fig. 250; the lower one from the pale,

and the upper from the red muscle. The latent period is longer, while the duration of a simple contraction of a red muscle is three



Fig. 250.

Curves obtained from a red (upper) and pale (lower) muscles of a rabbit, by stimulating the sciatic nerve with a single induction shock. The lowest line, T, indicates time, and is divided into $\frac{1}{100}$ second (Kronecker and Stirling).

times longer than that of a pale muscle. Four stimuli per second cause an incomplete tetanus, and 10 per second a nearly complete tetanus in the red muscles of a rabbit, while the pale muscles require 20–30 stimuli per second, to be completely tetanised. Fig. 251

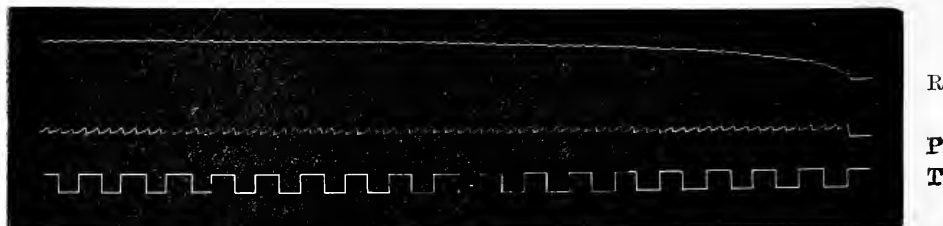

Fig. 251.

Opening and closing induction shocks of 300 units, applied at intervals of $\frac{1}{4}$ second to the pale (lower) and red (upper) muscles of a rabbit. The lowest line, T, marks $\frac{1}{4}$ second (Kronecker and Stirling).

shows the results produced by induction shocks applied to both muscles at intervals of $\frac{1}{4}$ second.]

The extent of shortening in a tetanically contracted muscle, within certain limits, is dependent upon the strength of the individual stimuli—but not upon their frequency. The contraction remainder after tetanus is greater the stronger the stimuli, the longer they are applied, and the feebler the muscle used (Bohr). Sometimes a stimulus applied to a muscle immediately after tetanus, produces a greater effect than it did before the tetanus (Rossbach, Bohr).

Duration of Tetanus.—A tetanised muscle cannot remain contracted to the same extent for an indefinite period, even if the stimuli are kept constant. It gradually begins to elongate, at first somewhat rapidly, and then more slowly, owing to the occurrence of fatigue. If the tetanic stimulation is arrested, the muscle does not regain its original position and shape at once, but a contraction remainder

exists for a certain time, this being more evident after stimulation with induction shocks.

O. Soltmann found that the *pale* muscles of new-born rabbits were rendered tetanic with 16 stimuli per second, so that tetanus was produced in them with the same number of shocks as in fatigued adult muscles. This may serve partly to explain the facility with which spasms occur in new-born animals.

Curarised muscles sometimes pass into tetanus on the application of a momentary stimulus (Kühne, Hering).

IV. If *very rapid induction shocks* (224–360 per second) be applied to a muscle, the tetanus after a so-called "initial contraction" (Bernstein) may cease (Harless, Heidenhain). This occurs most readily when the nerves are cooled (v. Kries). Kronecker and Stirling, however, found that stimuli following each other at greater rapidity than 24,000 per second produced tetanus.

[Tone-inductorium of Kronecker and Stirling.—This apparatus, Fig. 252, consists of a rod of iron, *d*, fixed in an iron upright at *a*. The primary, *s'*, and secondary spiral, *s''*, rest on wooden supports, which can be pushed over both ends of the rod. One end of the rod lies between leather rollers, *f* and *g*, which can be made to rub on the rod by moving the toothed wheels, *h*. In this way a tone is produced by the *longitudinal* vibrations of the rod, the number of vibrations being proportional to the length of the rod, so that by means of this instrument we can produce from 1,000 to 24,000 alternating induction shocks per second.]

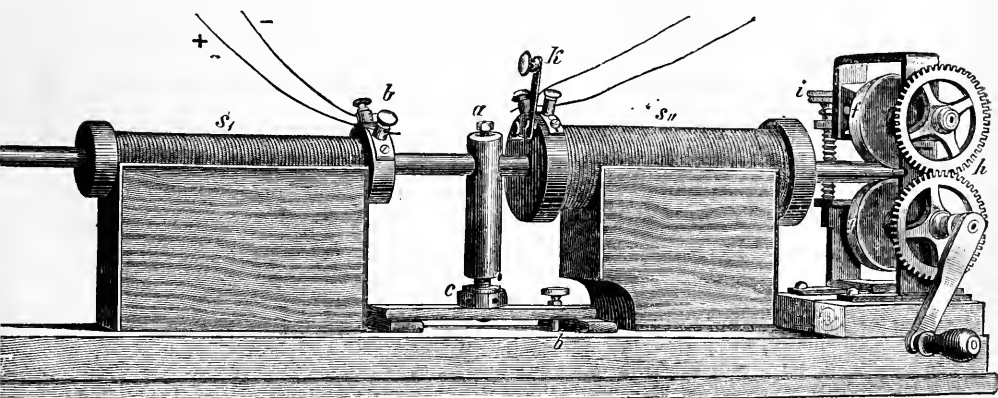

Fig. 252.

Tone-inductorium of Kronecker and Stirling—*d*, iron rod, clamped at *a*; *s'*, primary, *s''*, secondary spiral, with a key, *k*; leather rollers, *f* and *g*, driven by toothed wheels, *h* (Kronecker and Stirling).

[Fig. 253 shows tetanus of the triceps femoris of a frog stimulated by 8,000 induction shocks per second.]

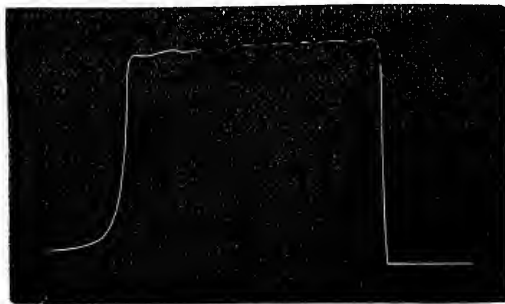

Fig. 253.

Triceps femoris of a frog weighted with 60 grammes, and stimulated by 8,000 induction shocks per second.

299. Rapidity of Transmission of a Muscular Contraction.

1. If a long muscle be stimulated *at one end*, a contraction occurs at that point, and is rapidly propagated in a *wave-like* manner through the whole length of the muscle, until it reaches its other end. The condition of excitement or molecular disturbance is communicated to each successive part of the muscle, in virtue of a special conductive capacity of the muscle. The mean velocity of the contraction wave is 3-4 metres per second in the frog (Bernstein, 3·869 metres); rabbit, 4-5 metres (Bernstein and Steiner); lobster, 1 metre (Frédéricq and Vandeveldé); in *smooth muscle* and in the heart, only 10-15 millimetres per second (Engelmann, Marchand—p. 101). These results have reference only to excised muscles, the velocity of transmission being much greater in the voluntary muscles of a living man—viz., 10-13 metres (Hermann—§ 334, II).

Methods.—Aeby placed writing-levers upon both ends of a muscle, the levers resting transversely to the direction of the muscular fibres. The muscle was stimulated, and both levers registered their movements, the one directly over the other, on a revolving cylinder. On stimulating one end of the muscle, the lever nearest to this point is raised by the contraction wave, and a little later, the other lever. When we know the rate at which the cylinder is moving, and the distance between the two elevations, it is easy to calculate the rapidity of transmission of the contraction wave.

Duration and Wave Length.—The time, corresponding to the length of the abscissa of the muscle-curve inscribed by each writing-lever, is equal to the *duration of the contraction* of this part of the muscle, (according to Bernstein, 0·053-0·098 second.) If this value be multiplied by the rapidity of transmission of the muscular contraction wave,

we obtain the *wave length* of the *contraction wave* (=206–380 millimetres).

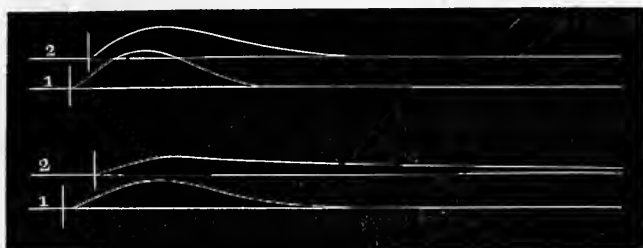

Fig. 254.

Upper two curves, 2 and 1, obtained from a rabbit's muscle by the above arrangement; the lower two curves, from the same muscle, when it was cooled by ice.

[Fig. 254 shows the effect of *cold* on the muscles of a rabbit, in delaying the contraction wave. There is a longer distance between 1 and 2 in the lower than in the upper curves.]

Modifying Influences.—Cold, fatigue, approaching death, and many poisons diminish the velocity and the height of the contraction wave (Fig. 254), while the strength of the stimulus and the extent to which the muscle is loaded are without any effect upon the velocity of the wave (Aeby). In excised muscles, the size of the wave diminishes as it passes along the muscle (Bernstein), but this is not the case in the muscles of living men and animals. The contraction wave never passes from one muscular fibre to a neighbouring fibre.

2. If a long muscle be stimulated *locally near its middle*, a contraction wave is propagated towards both ends of the muscle. If several points be stimulated simultaneously, a wave movement sets out from each, the waves passing over each other in their course (Schiff).

3. If a stimulus be applied to the *motor nerve* of a muscle, an impulse is communicated to *every muscular fibre*; a contraction wave begins at the *end-organ* [motorial end-plate], and must be propagated in both directions along the muscular fibres, whose length is only 3–4 centimetres. As the length of the motor-fibres from the nerve-trunk to where they terminate in the motorial end-plates is unequal, contraction of all the muscular fibres cannot take place absolutely at the same moment, as the nerve impulse takes a certain time to travel along a nerve. Nevertheless, the difference is so small that, when a muscle is caused to contract by stimulation of its motor nerve, practically the whole muscle appears to contract simultaneously and at once.

4. *A complete, uniform, momentary contraction of all the fibres of a muscle can only take place, when all the fibres are excited at the same*

moment. This occurs when the electrodes are placed at both ends of the muscle, and an electrical stimulus of momentary duration passes through the whole length of the muscle.

300. Muscular Work.

Muscles are most perfect machines, not only because they make the most thorough use of the substances on which their activity depends (p. 448), but they are distinguished from all machines of human manufacture by the fact that, by frequent exercise they become stronger, and are thereby capable of accomplishing more work (du Bois-Reymond).

The amount of work (W) which a muscle can perform (see p. xxiii.) is equal to the product of the weight lifted (p) and the height to which it is lifted (h), *i.e.*, $W = p h$. Hence, it follows that when a muscle is not loaded (where $p = 0$), then w must be $= 0$, *i.e.*, no work is performed. If, again, it be overloaded with too great a load, so that it is unable to contract ($h = 0$), here also the work is nil. Between these two extremes, an active muscle is capable of doing a certain amount of "work."

I. Work with Maximal Stimulation.—When the strongest possible, or maximal, stimulus is applied, *i.e.*, when the strength of the stimulus is such as to cause a muscle to contract to the greatest possible extent of which it is capable, the amount of work done increases more and more as the weight is increased, but only up to a certain maximum. If the weight be gradually increased, so that it is lifted to a less height, the amount of work diminishes more and more, and gradually falls to be $= 0$, when the weight is not lifted at all.

The following example of the work done by a frog's muscle, given by Ed. Weber, illustrates this law:—

Weight Lifted in Grammes.	Height in Millimetres.	Work Done in Gramme-Millimetres.
5	27·6	138
15	25·1	376
25	11·45	286
30	7·3	220

[Suppose a muscle to be loaded with a certain number of grammes, and then caused to contract, we get a certain height of contraction. Fig. 255 shows the result of an experiment of this kind. The vertical lines represent the height to which the weights (in grammes) noted

under them were raised, so that, as a rule, as the weight increases, the height to which it is raised decreases.]

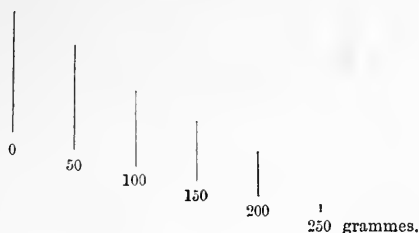

Fig. 255.

Height to which each of the weights is raised.

Laws of Muscular Work.—1. A muscle can lift a greater load, the larger its transverse section, *i.e.*, the more fibres it contains arranged parallel to each other (Eduard Weber, 1846).

2. The longer the muscle, the higher it can lift a weight (Joh. Bernoulli, 1721).

3. When a muscle begins to contract, it can lift the largest load; as the contraction proceeds it can only lift less and less loads, and when it is at its maximum of shortening, only relatively very light loads (Th. Schwann, 1837).

4. By the term, “absolute muscular force,” is meant, according to Ed. Weber, just the weight which a muscle undergoing maximal stimulation is no longer able to lift (the muscle being in its normal resting phase), and without the muscle at the moment of stimulation being elongated by the weight.

Insects can perform an extraordinary amount of work—an insect can drag along sixty-seven times its body-weight; a horse scarcely three times its own weight.

5. During *tetanus*, when a weight is kept suspended, no work is done as long as the weight is kept suspended, but of course work is done in the act of lifting the load. To produce tetanus, successive stimuli are required, the muscular metabolism is increased, and fatigue rapidly occurs. The potential energy in this case is converted into heat (§ 302).

When a muscle is stimulated with a *maximal stimulus*, it cannot lift so great a weight with *one* contraction as when it is stimulated tetanically (Hermann). The energy evolved, even during tetanus, is greater the more frequent the stimulation (Bernstein), at least up to 100 stimuli per second.

II. Medium Stimuli.—If a muscle be caused to contract by stimuli of *moderate strength*, *i.e.*, such as do not cause a maximal contraction, there are two possibilities: Either the feeble stimulus is kept constant

whilst the load is varied, in which case the amount of work done follows the same law as obtains for maximal stimulation; or, the load may be kept the same, whilst the strength of the stimulus is varied. In the latter case, Fick observed that the height to which the load was lifted increased in a direct ratio with the strength of the stimulus.

The blood-stream within the muscles of an intact body is increased during muscular activity. The blood-vessels of the muscle *dilate*, so that the amount of blood flowing through them is increased (Ludwig and Sczelkow). At the time that the motor-fibres are excited, so also are the vaso-dilator fibres, which lie in the same nervous channels (§ 294, II.).

[Gaskell found that faradisation of the nerve of the mylohyoid muscle of the frog, not only caused tetanus of the muscle, but also dilatation of its blood-vessels.]

Testing Individual Muscles.—In estimating the *absolute force* of the *individual muscles* or groups of muscles in man, we must always pay particular attention to the physical relations—*i.e.*, to the arrangement of the levers, direction of the traction, degree of shortening, &c. (§ 306).

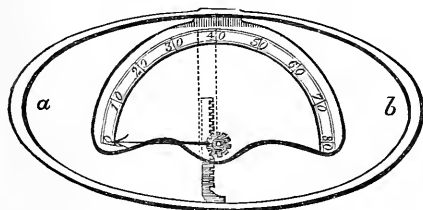

Fig. 256.

Dynamometer of Mathieu.

Dynamometer.—The absolute force of certain groups of muscles is very conveniently and practically ascertained by means of a dynamometer (Fig. 256). This instrument is very useful for testing the difference between the power of the two arms in cases of paralysis. The patient grasps the instrument in his hand and an index registers the force exerted.

Quetelet has estimated the force of certain muscles—the pressure of both hands of a man to be = 70 kilos.; while by pulling he can move double this weight. The force of the female hand is one-third less. A man can carry more than double his own weight; a woman about the half. Boys can carry about one-third more than girls. [Very convenient dynamometers are made by Salter of Birmingham, both for testing the strength of *pull* and *squeeze*; in testing the former, the instrument is held as an archer holds his bow when in the act of drawing it, and the strength of pull is given by an index; in the latter, another form of the instrument is used. Large numbers of observations were made by means of these instruments by Francis Galton at the Health Exhibition.]

Amount of Work Daily.—In estimating the work done by a man, we have to consider, not only the amount of work done at any one moment, but how often time after time, he can succeed in doing work. The *mean value* of the daily work of a man, working eight hours a day, is 10 (10.5 to 11 at most) kilogramme-metres per second—*i.e.*, a daily amount of work = 288,000 (300,000) kilogramme-metres.

Modifying Conditions.—Many substances, after being introduced into the body, diminish, and ultimately paralyse the production of work—mercury, digitalin, helleborin, potash salts, &c. Others increase the muscular activity—veratrin (Rossbach), glycogen, muscarin (Klug and Fr. Högyes), kreatin, and hypoxanthin; extract of meat rapidly restores the muscles after fatigue (Kobert).

301. The Elasticity of Muscle.

Physical.—Every elastic body has its “natural shape”—*i.e.*, its shape when no external force (tension or pressure) acts upon it so as to distort it. Thus, the passive muscle has a “natural form.” If, however, a muscle be extended in the course of its fibres, the parts of the muscle are evidently pulled asunder. If the stretching be carried only to a certain degree, the muscle, in virtue of its elasticity, will regain its natural form. Such a body is said to possess “*complete elasticity*”—*i.e.*, after being stretched, it regains exactly its original shape. By the term “*amount of elasticity*” (*modulus*) is meant the weight (expressed in kilogrammes) necessary to extend an elastic body 1 □ millimetre in diameter, its own length, without the body breaking. Of course, many bodies are ruptured before this occurs. For a passive muscle it is = 0·2734 (Wundt), [that of bone = 2264 (Wertheim), tendon = 1·6693, nerve = 1·0905, the arterial walls = 0·0726 (Wundt).] Thus, the amount of elasticity of a passive muscle is small, as it requires only a light stretching force to extend it to its own length. It has, therefore, no great amount of elasticity. The term “*coefficient of elasticity*” is applied to the fraction of the length of an elastic body, to which it is elongated by the unit of weight applied to stretch it. It is large in a passive muscle. If the tension be sufficiently great, the elastic body ruptures at last. The “*carrying capacity*” of muscular tissue, until it ruptures, is in the following ratios for youth, middle, and old age, nearly 7 : 3 : 2.

Curve of Elasticity.—In inorganic elastic bodies, the line of elongation, or the *extension*, is *directly proportional to the extending weight*; in organic bodies, and therefore in muscle, this is not the case, as the weight is continually increased by equal increments—the muscle is less extended than at the beginning, so that the extension is *not proportional to the weight*. If equal weights be added to a scale-pan attached to a piece of india-rubber with a writing-lever connected with it, and writing its movements on a plate of glass that can be moved with the hand, we get such a curve as in Fig. 257, I; while, if the same be done with the sartorius of a frog, we get a result similar to Fig. 257, II. A straight line joins the apices of the former, while the



I.

Fig. 257.

II.

Curve of elasticity—I, from an inorganic body like india-rubber; and II, from the sartorius of a frog obtained by adding equal increments of weight at A, B, C, D, etc. (after Marey).

curve of elasticity is a *hyperbola*, or something near it, in the latter case.

Elastic After-Effect.—At the same time, after the first elongation, corresponding to the extending weight, is reached, the muscle may remain for days, and even weeks, somewhat elongated. This is called

the "*elastic after-effect*" (p. 126). [Marey attached a lever to a frog's muscle, and allowed the latter to record its movements on a slowly

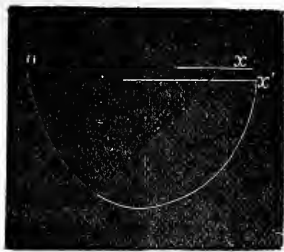

Fig. 258.

Curve of elasticity produced by the continuous extension and recoil of a frog's muscle; o , x , abscissa before, x' after the extension.

revolving cylinder. To the lever was fixed a vessel into which mercury slowly flowed. This extended the muscle, and when it had ceased to elongate, the mercury was allowed slowly to run out again. The curve obtained is shown in Fig. 258. The abscissæ, o , x and x' , indicate the position of the writing-style before and after the experiment, and we observe that x' is lower than o , x , so that the recoil is imperfect. There has been an actual elongation of the muscle, so that the limit of its elasticity is exceeded. Although a frog's gastrocnemius

may be loaded with 1,500 grammes without rupturing it, 100 grammes will prevent it regaining its original length.]

Method.—In order to test the *elasticity* of a muscle, fix it to a support provided with a graduated scale, and to the lower end of the muscle attach a scale-pan into which are placed various weights, measuring on each occasion the corresponding elongation of the muscle thereby obtained (Ed. Weber). In order to obtain the *curve of elongation*, take as abscissæ the successive units of weight added, and the elongation corresponding to each weight as ordinates.

The elasticity of passive muscle is *small*, but *very complete*, and is comparable to that of a caoutchouc fibre. Small weights greatly elongate the muscle. If the weights be uniformly increased, there is not a uniform elongation; with equal increments of weight, the greater the load, the increase in elongation always becomes less; or, to express it in another way, the amount of elasticity of the passive muscle increases with its increased extension (Ed. Weber).

The following example from the hyoglossus of the frog shows this relation:—

Weight in Grammes.	Length of the Muscle in Millimetres.	Extension.	
		In Millimetres.	Percentage.
0·3	24·9
1·3	30·0	5·1	20
2·3	32·3	2·3	7
3·3	33·4	1·1	3
4·3	34·2	0·8	2
5·3	34·6	0·4	1

In inorganic bodies, the curve of extension is a *straight line*, but in organic bodies, it more closely resembles a *hyperbola* (Wertheim). The elasticity of a passive *fatigued* muscle does not differ essentially from that of a non-fatigued muscle.

Muscles in the living body, and still in connection with their nerves and blood-vessels, are more extensible than excised ones. Muscles, when quite fresh, are elongated (within certain small limits as regards the weight) at first with a uniformly increasing weight, to an extent proportional to the latter, just as with an inorganic body. When heavy weights are used, we must be careful to take into consideration the "*elastic after-effect*" (p. 126—Wundt).

The volume of a stretched muscle is slightly less than an unstretched one, similar to the contracted (§ 297, 2) and stiffened muscle (p. 639).

Dead muscles and muscles in *rigor mortis* have greater elasticity—*i.e.*, they require a heavier weight to stretch them—than fresh muscles; but, on the other hand, the elasticity of dead muscles is less complete—*i.e.*, after they are stretched they only recover their original form within certain limits.

Elasticity of Intact Muscles.—Normally, within the body, the muscles are stretched to a very slight extent, as can be shown by the slight degree of retraction which occurs when the insertion of a muscle is divided. This slight degree of extension, or stretching, is important. If this were not so, when a muscle is about to contract, and before it could act upon a bone as a lever, it would have to take in so much slack. The elasticity of muscles is manifested during the contraction of antagonistic muscles. The position of a passive limb depends upon the resultant of the elastic tension of the different muscle groups.

The elasticity of an active muscle is less than that of a passive muscle, *i.e.*, it is elongated by the same weight to a greater extent than a passive muscle. For this reason, the active muscle, as can be shown in an excised contracted muscle, is *softer*; the apparently great hardness manifested by stretched contracted muscles depends upon their tension. When the active muscle becomes *fatigued*, its elasticity is diminished (p. 668).

Method.—Ed. Weber took the hyoglossus muscle of a frog and suspended it vertically, noticing its length when it was passive. It was then tetanised with induction shocks, and its height again noted. One after the other heavier weights were attached to it, and the length of the passive and tetanised muscle observed for each weight. The extent to which the active loaded muscle shortened from the position of the passive loaded muscle he called the "*height of the lift*" (or *Hubhöhe*).

The latter becomes less as the weight increases, and lastly, the tetanised muscle may be so loaded that it cannot contract, *i.e.*, the height of the lift is = 0.

Weber's Paradox.—The case may occur where, when a muscle is so loaded that it cannot contract when it is stimulated, it may even *elongate*. According to Wundt, even in this condition the elasticity is not changed. [The usual explanation given is that, as the elasticity of a muscle is diminished during contraction, it is more extended with the same weight in the contracted as compared with the passive or uncontracted state, so that a heavily weighted muscle, when stimulated, may elongate instead of shortening].

Poisons.—Potash causes shortening of a muscle with simultaneous increase of its elasticity. Digitalin produces other changes with increased elasticity. Physostigmin increases it, while veratrin diminishes it, and interferes with its completeness (Rossbach and v. Anrep), and tannin makes a muscle less extensible, but more elastic (Lewin). Ligature of the blood-vessels produces at first a decrease, and then an increase of the elasticity; section of the motor nerve diminishes the elasticity (v. Anrep).

Eduard Weber concluded from his experiments, that a muscle assumes two forms, the active and the passive form. Each of these corresponds to a special natural form. The passive muscle is longer and thinner—the active is shorter and thicker in form. The passive as well as the active muscle strives to retain its form. If the passive muscle be set into activity, the passive rapidly changes into the active form, in virtue of its elastic force. The latter is the energy which causes muscular work. Schwann compared the force of an active muscle to a long, elastic, tense spiral spring. Both can lift the greatest weight, only from that form, in which they are most stretched. The more they shorten, the less the weight which they can lift.

302. Formation of Heat in an Active Muscle.

After Bunzen, in 1805 (§ 209, 1, *b*), showed that, during muscular activity, heat is evolved, v. Helmholtz proved that an *excised* frog's muscle, when *tetanisised* for 2–3 minutes, caused an increase of its temperature of 0.14° – 0.18° C. R. Heidenhain succeeded in showing an increase of 0.001° – 0.005° C. for each *single contraction*. The heart is warmed during every systole (Marey).

[Method.—The rise in temperature of a frog's muscle may be estimated by placing the two gastrocnemii of a frog's muscle on the two junctions of a thermo-electric pile, connected with a heat galvanometer. Of course, when the two muscles are at the same temperature, the needle of the galvanometer is stationary; but, if one muscle be made to contract, or is tetanised, then an electrical current is set up which deflects the needle (§ 208, B).]

The following facts have been ascertained with regard to the development of heat:—

1. **Relation to Work.**—It bears a relation to the amount of work.

(*a.*) If a muscle during contraction carries a weight which extends it again during rest, no work is transferred beyond the muscle (§ 300). In this case, all the chemical potential energy during this movement is converted into heat. Under these circumstances, the amount of heat evolved runs parallel with the amount of work done, *i.e.*, it increases as the load and the height increase up to a maximum point, and afterwards diminishes as the load is increased. The heat maximum is reached with a less load sooner than the work maximum (Heidenhain).

(b.) If when the muscle is at the height of its contraction, the *load be removed*, then the muscle has produced work referable to something outside itself; in this case, the amount of heat produced is less (A. Fick). The amount of work produced, and the diminished amount of heat formed, when taken together, represent the same amount of energy, corresponding to the law of the conservation of energy (p. xxv.).

(c.) If the same amount of work is performed in one case by many but small contractions, and in another by fewer but larger contractions, then in the latter case, the amount of heat is greater (Heidenhain and Nawalichin). This shows that larger contractions are accompanied by a relatively greater metabolism of the muscular substance than small contractions, which is in harmony with practical experience; thus, the ascent of a tower with steep high steps causes fatigue more rapidly (metabolism greater) than the ascent of a more gentle slope with lower steps.

(d.) If the weighted muscle executes a series of contractions one after the other, and at the same time does work, then the amount of heat it produces is greater than when it is tetanic, and keeps a weight suspended. Thus, the transition of the muscle into a shortened form causes a greater production of heat than the maintenance of this form (A. Fick).

2. **Relation to Tension.**—The amount of heat evolved depends upon the *tension of the muscle*; it also increases as the muscular tension increases (Heidenhain). If the ends of a muscle be so fixed that it cannot contract, the maximum of heat is obtained (Béclard). Such a condition occurs during tetanus, in which condition the violently contracted muscles oppose each other. Very high temperatures have been registered by Wunderlich in this condition (p. 440), and the same is true of animals that are tetanised (Leyden). Dogs kept in a state of tetanus by electrical stimulation die, because their temperature rises so high (44°–45°C.) that life no longer can be maintained (Richet). In addition to this great formation of heat, there is a considerable amount of *acid*, and of alcoholic extractives produced in the muscular tissue.

3. **Relation to Stretching.**—Heat is also evolved during the *elongation* or relaxation of a contracted muscle, *e.g.*, by causing a muscle to contract without the addition of any weight, and loading it when it begins to relax (Steiner, Schmulewitsch and Westerman), whereby heat is produced.

4. The formation of heat diminishes as the muscular fatigue increases (A. Fick).

The amount of work and heat in a muscle must always correspond to the transformation of an equivalent amount of chemical energy. A greater part of this energy

is manifested as work, the greater the resistance that is offered to the muscular contraction. When the resistance is great, $\frac{1}{2}$ of the chemical energy may be manifested as work, but when it is small, only a small part of it is so converted (A. Fick, Harteneck).

It was stated that a nerve in action is $\frac{1}{100}^{\circ}$ C. warmer (Valentin), but this is denied by v. Helmholtz and Heidenhain.

303. The Muscle-Sound.

Muscle-Sound.—When a muscle contracts, and is at the same time kept in a state of tension by the application of sufficient resistance, it emits a distinct sound or *tone*, depending upon the intermittent variations of tension occurring within it (Wollaston).

The muscle-sound was known to Swammerdam, Roger, Haller, Grimaldi and others.

Methods.—The muscle-sound may be heard by placing the ear over the tetanically contracted and tense biceps of another person; or we may insert the tips of our index fingers into our ears, and forcibly contract the muscles of our arm; or the sound of the muscles that close the jaw may be heard by forcibly contracting them, especially at night when all is still, and when the outer ears are closed. v. Helmholtz found that this tone coincides with the resonance tone of the ear, and he thought that the vibrations of the muscles caused this resonance tone. The sound of an isolated frog's muscle may be heard by placing one end of a rod in the ear, the other ear being closed. To the other end of the rod is attached a loaded frog's muscle kept in a tetanic condition.

The pitch of the note, *i.e.*, the number of vibrations, may be estimated by comparing the muscle-sound with that produced by elastic springs vibrating at a known rate.

When a muscle contracts voluntarily, *i.e.*, through the will, it makes 19.5 vibrations per second. We do not hear this very low tone, owing to the number of vibrations per second being too few, but what we actually hear is the *first overtone*, with double the number of vibrations. The muscle-sound has 19.5 vibrations, when the muscles of an animal are caused to contract, by stimulating its *spinal cord* (v. Helmholtz), and also when the *motor nerve-trunk* is excited by chemical means (Bernstein).

If, however, *tetanisng induction shocks* be applied to a muscle, then the number of vibrations of the muscle-sound corresponds exactly with the number of vibrations of the vibrating spring or hammer of the induction apparatus. Thus, the tone may be raised or lowered by altering the tension of the spring. Lovén found that, the muscle-sound was loudest when the weakest currents capable of producing tetanus were employed. The sound corresponded to the number of vibrations of the octave just below it in the scale. With stronger currents the muscle-sound disappears, but it reappears with the same number of vibrations as that of the interruptor of the induction apparatus, if still stronger currents are used.

If the induction shocks be applied to the nerve, the sound is not so loud, but it has the same number of vibrations as the interruptor. With rapid induction shocks, tones caused by 704 (Lovèn) and 1000 vibrations per second have been produced (Bernstein).

The first heart-sound is partly muscular (p. 92).

The muscle-sound is regarded as a sign that tetanus is due to a series of single variations of the density of the muscle (§ 298, III).

304. Fatigue of Muscle.

Fatigue.—By the term fatigue, is meant that condition of diminished capacity for work, which is produced in a muscle by prolonged activity. This condition is accompanied in the living person with a peculiar feeling of lassitude, which is referred to the muscles. A fatigued muscle rapidly *recovers* in a living animal, but an excised muscle recovers only to a slight extent (Ed. Weber, Valentin).

The cause of fatigue is probably the accumulation of decomposition products, "*fatigue stuffs*" in the muscular tissue, these products being formed within the muscle itself during its activity. They are phosphoric acid, either free or in the form of acid phosphates, *acid potassium phosphate* (p. 627), glycerin-phosphoric acid (?) and CO_2 . If these substances be removed from a muscle, by passing through its blood-vessels an indifferent solution (0.6 per cent.) of common salt, or a weak solution of sodium carbonate [or a dilute solution of permanganate of potash (Kronecker)], the muscle again becomes capable of energising (J. Ranke, 1863). The using up of O by an active muscle favours fatigue (v. Pettenkofer and v. Voit). The transfusion of *arterial blood* (not of venous—Bichat), removes the fatigue (Ranke, Kronecker), probably by replacing the substances that have been used up in the muscle. Conversely, an actively energising muscle may be rapidly fatigued by injecting into its blood-vessels a dilute solution of phosphoric acid (J. Ranke), of acid potassium phosphate, or dissolved extract of meat (Kemmerich). A muscle fatigued in this way absorbs less O, and when so fatigued, it evolves only a small amount of acids and CO_2 . The conditions which lead up to fatigue are connected with considerable metabolism in the muscular tissue.

Modifying Conditions.—In order to obtain the same amount of work from a fatigued muscle, a much more powerful stimulus must be applied to it than to a fresh one. A fatigued muscle is incapable of lifting a considerable load, so that its absolute muscular force is diminished. If, during the course of an experiment, a muscle be loaded with the same weight, and if the muscle be stimulated at regular intervals with maximal stimuli (strong induction shocks), contraction

after contraction gradually and regularly diminishes in height, the decrease being a constant fraction of the total shortening. Thus the fatigue curve is represented by a *straight line*, [*i.e.*, a straight line will touch the apices of all the contractions].

The more rapidly the contractions succeed each other, the greater is the fall in the height of the contraction, [*i.e.*, if the *interval* between the contractions be short, the fatigue curve falls rapidly towards the abscissa], and conversely. After a certain number of contractions, an excised muscle becomes exhausted. This result occurs whether the stimuli are applied at short or long intervals (Kronecker), and a similar result is obtained with sub-maximal stimuli (Tiegel). A fatigued muscle contracts more *slowly* than a fresh one, while the latent period is also longer during fatigue (p. 649). The fatigued muscle is said to be more extensible (Donders and van Mansvelt). If a muscle be so loaded that when it contracts it cannot lift the load, fatigue occurs even to a greater extent than when the load is such that the muscle can lift it (Leber). The metabolism and the formation of acid are greater in a contracted muscle kept on the stretch, than in a contracted muscle allowed to shorten (Heidenhain). If a muscle contract, but is not required to lift any load, it becomes fatigued only very gradually. If a muscle be loaded only during contraction, and not during relaxation, it is fatigued more slowly than when it is loaded during both phases; and the same is true, when a muscle has to lift its load only during the *course* of its contraction, instead of at the beginning of the contraction. Loads may be suspended to perfectly passive muscles without fatiguing them (Harless, Leber).

Blood Supply.—If the arteries of a mammal be ligatured, stimulation of the motor nerves produces complete fatigue after 120–240 contractions (in 2–4 minutes), but direct muscular stimulation still causes the muscles to contract. In both cases, the fatigue curve is in the form of a straight line. If the bloods supply to a mammalian muscle be normal, on stimulating the motor nerve, the muscular contractions at first increase in height and then fall, their apices forming a straight line (Rossbach and Harteneck).

Recovery from the condition of fatigue is promoted by passing a *constant electrical current* through the entire length of the muscle (Heidenhain); also by injecting fresh arterial blood into its blood-vessels, or by very small doses of veratrin [or permanganate of potash].

If the muscle of an intact animal be stimulated continuously (fourteen days or thereby), until complete fatigue occurs, the muscular fibres become granular and exhibit a wax-like degeneration. The transverse striation is still visible, as long as the sarcous substance is in large masses, but as soon as it breaks up into small pieces, the transverse striation disappears completely (O. Roth).

Poisons.—Curara and the ptomaines cause an irregular course of the fatigue curve (Guareschi and Mosso).

305. Mechanism of the Joints.

I. The joints permit the freest movements of one bone upon another, [such as exist between the extremities of the bones of the limbs. In other cases, sutures are formed, which, while permitting no movement, allow the contents of the cavity which they surround to enlarge, as in the case of the cranium.] The articular end of a fresh bone is covered with a thin layer or plate of hyaline cartilage, which in virtue of its elasticity moderates any shocks or impulses communicated to the bones. The surface of the articular cartilage is perfectly smooth, and facilitates an easy gliding movement of the one surface upon the other. At the outer boundary line of the cartilage, there is fixed the *capsule* of the joint, which encloses the articular ends of the bones like a sac. The inner surface of the capsule is lined by a synovial membrane, which secretes the sticky, semi-fluid, *synovia*, moistening the joint. The outer surface of the capsule is provided at various parts with bands of fibrous tissue, some of which strengthen it, whilst others *restrain* or limit the movements of the joint. Some osseous processes limit the movements of particular joints, *e.g.*, the coronoid process of the ulna, which permits the fore-arm to be flexed on the upper arm only to a certain extent; the olecranon, which prevents over-extension at the elbow joint. The joint surfaces are kept in apposition—1, by the adhesion of the synovia-covered smooth articular surfaces; 2, by the capsule and its fibrous bands; and 3, by the elastic tension and contraction of the muscles.

[**Structure of Articular Cartilage.**—The thin layer of hyaline encrusting cartilage, is fixed by an irregular surface upon the corresponding surface of the head of the bone. In a vertical section through the articular cartilage of a bone, which has been softened in chromic or other suitable acid, we observe that the cartilage cells are flattened near the free surface of the cartilage, and their long axes are parallel to the surface of the joint: lower down, the cells are arranged in irregular groups, and further down still nearer the bone, in columns or rows, whose long axis is in the long axis of the bone. These rows are produced by transverse cleavage of pre-existing cells. In the upper two-thirds or thereby, the matrix of the cartilage is hyaline, but in the lower third near the bone, the matrix is granular and sometimes fibrillated. This is the *calcified zone*, which is impregnated with lime salts, and sharply defined by a *nearly straight line* from the hyaline zone above it, and by a *bold wavy line* from the osseous head of the bone.]

Synovial Membrane.—Synovial membrane consists of bundles of delicate connective-tissue mixed with elastic-tissue, while on its inner surface it is provided with folds, some of which contain fat, and others blood-vessels (synovial villi). The inner surface is lined with endothelium. The intra-capsular ligaments and cartilages are not covered by the synovial membrane, nor are they covered by endothelium.

The *synovia* is a colourless, stringy, alkaline fluid, with a chemical composition closely allied to that of transudations, with this difference, that it contains much

mucin, together with albumin, and traces of fat. Excessive movement diminishes its amount, makes it more inspissated, and increases the mucin, but diminishes the salts.

Joints may be divided into several classes, according to the kind of movement which they permit :—

1. *Joints with movement around one axis: (a.) The Ginglymus, or Hinge Joint.*—The one articular surface represents a portion of a cylinder or sphere, to which the other surface is adapted by a corresponding depression, so that when flexion or extension of the joint takes place, it moves only on *one axis* of the cylinder or sphere. The joints of the fingers and toes are hinge joints of this description. *Lateral ligaments*, which prevent a lateral displacement of the articular surfaces, are always present.

The Screw-hinge Joint is a modification of the simple hinge form (Langer, Henke), *e.g.*, the humero-ulnar articulation. Strictly speaking, simple flexion and extension do not take place at the elbow joint, but the ulna moves on the capitellum of the humerus, like a nut on a bolt ; in the right humerus, the screw is a right spiral, in the left, a left spiral. The ankle joint is another example ; the nut or female screw is the tibial surface, the right joint is like a left-handed screw, the left the reverse. (*b.*) The pivot joint (*rotatoria*), with a cylindrical surface, *e.g.*, the joint between the atlas and the axis, the axis of rotation being around the odontoid process of the axis. In the acts of *pronation* and *supination* of the fore-arm at the elbow joint, the axis of rotation is from the middle of the cotyloid cavity of the head of the radius to the styloid process of the ulna. The other joints which assist in these movements, are *above*, the joint between the circumferential part of the head of the radius, and the sigmoid cavity of the ulna, and *below*, the joint between the sigmoid cavity of the radius, which moves over the rounded lower end of the ulna.

2. *Joints with movements around two axes: (a.)* Such joints have two unequally curved surfaces which intersect each other, but which lie in the same direction, *e.g.*, the atlanto-occipital joint, or the wrist joint, at which lateral movements, as well as flexion and extension, take place. (*b.*) Joints with curved surfaces which intersect each other, but which do not lie in the same direction. To this group belong the *saddle-shaped* articulations, whose surface is concave in one direction, but convex in the other, *e.g.*, the joint between the metacarpal bone of the thumb and the trapezium. The chief movements are—(1) flexion and extension, (2) abduction and adduction. Further, to a limited degree, movement is possible in all other directions ; and, lastly, a pyramidal movement can be described by the thumb.

3. *Joints with movement on a spiral articular surface (spiral joints),*

e.g., the knee joint [Goodsir]. The condyle of the femur, curved from before backwards, in the antero-posterior section of its articular surface represents a *spiral* (Ed. Weber), whose centre lies nearer the posterior part of the condyle, and whose radius vector increases from behind, downwards and forwards. Flexion and extension are the chief movements. The strong lateral ligaments arise from the condyles of the femur, corresponding to the centre of the spiral, and are inserted into the head of the fibula and internal condyle of the tibia. When the knee joint is strongly flexed, the lateral ligaments are relaxed—they become tense as the extension increases; and when the knee joint is fully extended, they act quite like tense bands, which secure the lateral fixation of the joint. Corresponding to the spiral form of the articular surface, flexion and extension do not take place around *one* axis, but the axis moves continually with the point of contact; the axis moves also in a spiral direction. The greatest flexion and extension covers an angle of about 145° . The anterior crucial ligament is more tense during extension, and acts as a check ligament for too great extension, while the posterior is more tense during flexion and is a check ligament for too great flexion. The movements of extension and flexion at the knee are further complicated by the fact that, the joint has a screw-like movement, in that during the greatest extension, the leg moves outwards. Hence, the thigh, when the leg is fixed, must be rotated outwards during flexion. Pronation and supination take place during the greatest flexion to the extent of 41° (Albert) at the knee joint, while with the greatest extension it is nil. It occurs because the external condyle of the tibia rotates on the internal. In all positions during flexion, the crucial ligaments are fairly and uniformly tense, whereby the articular surfaces are pressed against each other. Owing to their arrangement, during increasing tension of the anterior ligament (extension), the condyles of the femur must roll more on to the anterior part of the articular surface of the tibia, while by increasing tension of the posterior ligament (flexion), they must pass more backward.

4. *Joints with the axis of rotation round one fixed point.* These are the freely movable *arthrodial* joints. The movements can take place around innumerable axes, which all intersect each other in the centre of rotation. One articular surface is nearly spherical, the other is cup-shaped. The shoulder and hip joints are typical "*ball-and-socket joints.*" We may represent the movements as taking place around *three* axes, intersecting each other at right angles. The movements which can be performed at these joints may be grouped as:—(1) pendulum-like movements in any plane, (2) rotation round the long axis of the limb, and (3) circumscribing movements [circumduction], such as are made

round the circumference of a sphere; the centre is in the point of rotation of the joint, while the circumference is described by the limb itself.

Limited arthrodial joints are ball joints with limited movements, and where rotation on the long axis is wanting, *e.g.*, the metacarpophalangeal joints.

5. Rigid joints or amphiarthroses are characterised by the fact, that movement may occur in all directions, but only to a very limited extent, in consequence of the very tough and unyielding external ligaments. Both articular surfaces are usually about the same size, and are nearly plane surfaces, *e.g.*, the articulations of the carpal and the tarsal bones.

II. Symphyses, synchondroses, and syndesmoses unite bones without the formation of a proper articular cavity, are movable in all directions, but only to the very slightest extent. Physiologically, they are closely related to amphiarthrodial joints.

III. Sutures unite bones without permitting any movement. The physiological importance of the suture is that, the bones can still grow at their edges, which thus renders possible the distension of the cavity enclosed by the bones (Herm. v. Meyer).

306. Arrangement and Uses of the Muscles of the Body.

The muscles form 45 per cent. of the total mass of the body, those of the right side being heavier than those on the left (Ed. Weber).

Muscles may be arranged in the following groups, as far as their mechanical actions are concerned:—

A. *Muscles without a definite origin and insertion:*

1. The hollow muscles surrounding globular, oval, or irregular cavities, such as the urinary bladder, gall bladder, uterus, and heart; or the walls of more or less cylindrical canals (intestinal tract, muscular gland ducts, ureters, Fallopian tubes, vasa deferentia, blood-vessels, and lymphatics). In all these cases, the muscular fibres are arranged in several layers, *e.g.*, in a longitudinal and a circular layer, and sometimes also in an oblique layer. All these layers act together and thus diminish the cavity.

It is inadmissible to ascribe different mechanical effects to the different layers, *e.g.*, that the circular fibres of the intestine narrow it, while the longitudinal dilate it. Both sets of fibres rather seem to act simultaneously, and diminish the cavity by making it narrower and

shorter at the same time. The only case where muscular fibres may act in partially dilating the cavity is when, owing to pressure from without or from partial contraction of some fibres, a fold, projecting into the lumen, has been formed. When the fibres, necessarily stretching across the depression thereby produced, contract, they must tend to undo it, *i.e.*, enlarge the cavity. The various layers are all innervated from the same motor source, which supports the view of their conjoint action.

2. The sphincters surround an opening or a short canal, and by their action they either constrict or close it, *e.g.*, sphincter pupillæ, palpebrarum, oris, pylori, ani, cunni, urethræ.

B. Muscles with a definite origin and insertion :

1. The origin is completely fixed when the muscle is in action. The course of the muscular fibres, as they pass to where they are inserted, permits of the insertion being approximated in a straight line towards their origin during contraction, *e.g.*, the attolens, attrahens, and retrahentes of the outer ear, and the rhomboidei. Some of these muscles are inserted into soft parts which necessarily must follow the line of traction, *e.g.*, the azygos uvulæ, levator palati mollis, and most of the muscles which arise from bone and are inserted into the skin, such as the muscles of the face, styloglossus, stylopharyngeus, &c.

2. Both Origin and Insertion movable.—In this case, the movements of both points are inversely as the resistance to be overcome. The resistance is often voluntary, which may be increased either at the origin or insertion of the muscle. Thus, the sternocleidomastoid may act either as a depressor of the head or as an elevator of the chest; the pectoralis minor may act as an adductor and depressor of the shoulder, or as an elevator of the 3rd–5th ribs (when the shoulder girdle is fixed).

3. Angular Course.—Many muscles having a fixed origin are diverted from their straight course; either their fibres or their tendons may be *bent* out of the straight course. Sometimes the curving is slight, as in the occipito frontalis and levator palpebræ superioris, or the tendon may form *an angle* round some bony process, whereby the muscular traction acts in quite a different direction, *i.e.*, as if the muscle acted directly from this process upon its point of insertion, *e.g.*, the obliquus oculi superior, tensor tympani, tensor veli palatini, obturator internus.

4. Many of the muscles of the extremities act upon the long bones as upon levers:—(a) Some act upon a lever with *one arm*, in which case the insertion of the muscle (power) and the weight lie upon one side of the fulcrum or point of support, *e.g.*, biceps, deltoid. The insertion of (or power) often lies very close to the fulcrum. In such a case, the *rapidity* of the movement at the end of the lever is greatly increased, but force is lost [*i.e.*, what is gained in rapidity is lost in power].

This arrangement has this advantage, that, owing to the slight contraction of the muscle, little energy is evolved, which would be the case had the muscular contraction been more considerable (§ 300, I., 3).
 (b) The muscles act upon the bones as upon a lever with *two arms*, in which case the power (insertion of the muscle) lies on the other side of the fulcrum opposite to the weight, *e.g.*, the triceps and muscles of the calf. In both cases, the muscular force necessary to overcome the resistance is estimated by the principles of the lever: equilibrium is established when the static moments (= product of the power in its vertical distance from the fulcrum) are equal; or when the power and weight are inversely proportional, as their vertical distance from the fulcrum.

Direction of Action.—It is most important to observe the *direction* in which the muscular force and weight act upon the lever arm. Thus, the direction may be vertical to the lever in one position, while after flexion, it may act obliquely upon the lever. The static moment of a power acting *obliquely* on the lever arm is obtained by multiplying the power with the power acting in a direction vertical to the point of rotation.

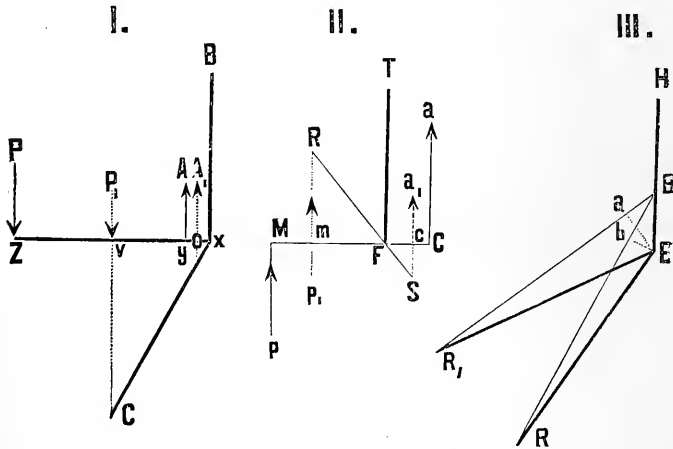

Fig 259.

Scheme of the action of muscles on bones.

Examples:—In Fig 259, I., Bx presents the humerus, and xZ the radius; $\underline{A}y$, the direction of the traction of the biceps. If the biceps acts at a right angle only, as by lifting horizontally a weight (P) lying on the fore-arm or in the hand, then the power of the biceps (= A) is obtained from the formula, $Ayx = PxZ$, *i.e.*, $A = (PxZ) : yx$. It is evident that, when the radius is depressed to the position xC, the result is different; then the force of the biceps = $A_1 = (P_1vx) : ox$. In Fig. 259, II., TF is the tibia, F, the ankle joint, MC, the foot in a horizontal position. The power of the muscles of the calf (= a) necessary to equalise a force,

p , directed from below against the anterior part of the foot, would be $a = (p \text{ M F}) : \text{F C}$. If the foot be altered to the position, R S, the force of the muscles of the calf would then be $a_1 = (p_1 \text{ M F}) : \text{F C}$.

In muscles also, which, like the coraco-brachialis, are stretched over the angle of a hinge, the same result obtains.

In Fig 259, ILL., H E is the humerus, E, the elbow joint, E R, the radius, B R, the coraco-brachialis. Its moment in this position is = A, b E. When the radius is raised to E R₁, then it is = A, a E. We must notice, however, that B R₁ < B R. Hence, the absolute muscular force must be less in the flexed position, because every muscle, as it becomes shorter, lifts less weight. What is lost in power is gained by the elongation of the lever-arm.

5. Many muscles have a **double action**; when contracted in the ordinary way, they execute a combined movement, *e.g.*, the biceps is a flexor and supinator of the fore-arm. If one of these movements be prevented by the action of other muscles, the muscle takes no part in the execution of the other movement.

If the fore-arm be strongly pronated and flexed in this position, the biceps takes no part therein; or, when the elbow joint is rigidly supinated, only the supinator brevis acts, not the biceps. The muscles of mastication are another example. The masseter elevates the lower jaw, and at the same time pulls it forward. If the depressed jaw, however, be strongly pulled backwards, when the jaw is raised, the masseter is not concerned. The temporal muscle raises the jaw, and at the same time pulls it backwards. If the depressed jaw be raised after being pushed forward, then the temporal is not concerned in its elevation.

6. **Muscles acting on two or more joints** are those which in their course from their origin to their insertion pass over two or more joints. Either the tendons may deviate from a straight course, *e.g.*, the extensors and flexors of the fingers and toes, as when the latter are flexed; or the direction is always straight, *e.g.*, the gastrocnemius. The muscles of this group present the following points of interest—(a) The phenomenon of so-called "*active insufficiency*" (Hueter, Henke). If the position of the joints over which these muscles pass be so altered, that their origin and insertion come too near each other, the muscle may require to contract so much before it can act on the bones attached to it, that it cannot contract actively any further than to the extent of the shortening from which it begins to be active; *e.g.*, when the knee joint is bent, the gastrocnemius can no longer produce plantar flexion of the foot, but the traction on the tendo achilles is produced by the soleus. (b) "*Passive insufficiency*" is shown by many-jointed muscles under the following circumstances:—In certain positions of the joint, a muscle may be so stretched that it may act like a rigid strap, and thus limit or prevent the action of other muscles, *e.g.*, the gastrocnemius is too short to permit complete dorsal flexion of the foot when the knee is extended. The long flexors of the

leg, arising from the tuber ischiï, are too short to permit complete extension of the knee joint, when the hip joint is flexed at an acute angle. The extensor tendons of the fingers are too short to permit of complete flexion of the joints of the fingers, when the hand is completely flexed.

7. Synergetic muscles are those which together subserve a certain kind of movement, *e.g.*, the flexors of the leg, the muscles of the calf, and others. The abdominal muscles act along with the diaphragm in diminishing the abdomen during straining, while the muscles of inspiration or expiration, even the different origins of one muscle, or the two bellies of a biventral muscle, may be regarded from the same point of view.

Antagonistic muscles (Galen) are those, which during their action, have exactly the opposite effect of other muscles, *e.g.*, flexors and extensors, pronators and supinators, adductors and abductors, elevators and depressors, sphincters and dilators, inspiratory and expiratory.

When it is necessary to bring the full power of our muscles into action, we quite involuntarily bring them beforehand into a condition of the greatest tension, as a muscle in this condition is in the most favourable position for doing work (§ 300, I., 3—Schwann). Conversely, when we execute delicate movements requiring little energy, we select a position in which the corresponding muscle is already shortened.

All the fasciæ of the body are connected with muscles, which, when they contract, alter the tension of the former, so that they are in a certain sense aponeuroses or tendons of the latter (K. Bardeleben). [For the importance of muscular movements and those of the fasciæ in connection with the movements of the lymph see § 201.]

307. Gymnastics—Pathological Variations of the Motor Functions.

Gymnastic exercise is most important for the proper development of the muscles and motor power, and it ought to be commenced in both sexes at an early age. Systematic muscular activity increases the volume of the muscles, and enables them to do more work. The amount of blood is increased with increase in the muscular development, while at the same time, the bones and ligaments become more resistant. As the circulation is more lively in an active muscle, gymnastics favour the circulation, and ought to be practised, especially by persons of sedentary habits, who are apt to suffer from congestion of blood in the abdominal organs (*e.g.*, hæmorrhoids), as it favours the movement of the tissue juices. [§ 201]. An active muscle also uses more O and produces more CO₂, so that respiration is also excited. The total increase of the metabolism gives rise to the feeling of well-being and vigour, diminishes abnormal irritability, and dispels the tendency to fatigue. The whole body becomes firmer, and specifically heavier (Jäger).

By **Ling's**, or the **Swedish** system, a systematic attempt is made to strengthen certain weak muscles or groups of muscles, whose weakness might lead to the production of deformities. These muscles are exercised systematically by opposing to them resistances, which must either be overcome, or against which the patient must strive by muscular action.

Massage, which consists in kneading, pressing, or rubbing the muscles, favours the blood-stream; hence, this system may be advantageously used for such muscles as are so weakened by disease, that an independent treatment by means of gymnastics cannot be adopted.

Disturbances of the normal movements may partly affect the *passive motor organs* (e.g., the bones, joints, ligaments and aponeuroses), or the *active organs* (muscles with their tendons, and motor nerves).

Passive Organs.—Fractures, caries and necrosis, and inflammation of the bones, which make movements painful, influence or even make movement impossible. Similarly, dislocations, relaxation of the ligaments, arthritis or ankylosis interfere with movement. Also curvature of bones, hyperostosis or exostosis; lateral curvature of the vertebral column (*Scoliosis*), backward angular curvature (*Kyphosis*), or forward curvature (*Lordosis*). The latter interfere with respiration. In the lower extremities, which have to carry the weight of the body, *genu valgum* may occur in flabby, tall, rapidly-growing individuals, especially in some trades, e.g., bakers. The opposite form, *genu varum*, is generally a result of rickets. *Flat foot* depends upon a depression of the arch of the foot, which then no longer rests upon its three points of support. Its causes seem to be similar to those of *genu valgum*. The ligaments of the small tarsal joints are stretched, and the long axis of the foot is usually directed outwards; the inner margin of the foot is more turned to the ground, while pain in the foot and malleoli make walking and standing impossible. Club-foot (*Talipes varus*) in which the inner margin of the foot is raised, and the point of the toes is directed inwards and downwards, depends upon imperfect development during foetal life. All children are born with a certain, very slight degree of bending of the foot in this direction. *Talipes equinus*, in which the toes, and *T. calcaneus*, in which the heel touches the ground, usually depend upon contracture of the muscles causing these positions of the foot, or upon paralysis of the antagonistic muscles.

Rickets and Osteomalacia.—If the earthy salts be withheld from the food, the bones gradually undergo a change; they become thin, translucent, and may even bend under pressure. In certain persistent defects of nutrition, the lime salts of the food are not absorbed, giving rise to *rachitis*, or rickets, in children. If fully formed bones lose their lime salts to the extent of $\frac{1}{3}$ to $\frac{1}{2}$ (*halisterisis*), they become brittle and soft (*osteomalacia*). This occurs to a limited extent in old age.

Muscles.—The normal nutrition of muscle is intimately dependent on a proper supply of *sodium chloride* and *potash salts* in the food, as these form integral parts of the muscular tissue (Kemmerich, Forster). Besides the atrophic changes which occur in the muscles when these substances are withheld, there are disturbances of the central nervous system and digestive apparatus, and the animals ultimately die. The condition of the muscles during inanition is given in § 237. If muscles and bones be kept inactive, they tend to atrophy (§ 244). In atrophic muscles, and in cases of ankylosis, there is an enormous increase, or "atrophic proliferation," of the muscle-corpuscles, which takes place at the expense of the contractile contents (Cohnheim). A certain degree of muscular atrophy takes place in old age.

The *uterus*, after delivery, undergoes a great decrease in size and weight—from 1000 to 350 grammes—due chiefly to the diminished blood supply to the organ. In chronic *lead poisoning*, the extensors and interossei chiefly undergo atrophy. Atrophy and degeneration of the muscles are followed by shortening and thinning of the bones to which the muscles are attached.

Section and paralysis of the motor nerves cause palsy of the muscles, thus rendering them inactive, and they ultimately degenerate. Atrophy also occurs after inflammation or softening of the *multipolar nerve-cells* in the anterior horn of the grey matter of the spinal cord, or the *motor nuclei* (facial, glosso-pharyngeal, spinal accessory, and hypoglossal of Stilling in the medulla oblongata), in the muscles connected with these parts. Rapid atrophy takes place in certain forms of spinal paralysis and in acute bulbar paralysis (paralysis of the medulla oblongata), and in a chronic form, in progressive muscular atrophy and progressive bulbar paralysis. The muscles and their nerves become small and soft. The muscles show many nuclei, the sarcous substance becomes fatty, and ultimately disappears. According to Charcot, these areas are at the same time the trophic centres for the nerves proceeding from them as well as for the muscles belonging to them. According to Friedreich, the primary lesion in progressive muscular atrophy is in the muscles, and is due to a primary interstitial inflammation of the muscle, resulting in atrophy and degenerative changes, while the nerve-centres are affected secondarily, just as after amputation of a limb the corresponding part of the spinal cord degenerates.

In *pseudohypertrophic muscular atrophy*, the muscular fibres atrophy completely, with copious development of fat and connective-tissue between the fibres, without the nerves or spinal cord undergoing degeneration. The muscular substance may also undergo *amyloid* or *wax-like* degeneration, whereby the amyloid substance infiltrates the tissue (§ 249, VI.). Sometimes atrophic muscles have a *deep-brown colour*, due to a change of the hæmoglobin of the muscle. When muscles are much used they *hypertrophy*, as the heart in certain cases of valvular lesion or obstruction (§ 49), the bladder, and intestine.

Special Motor Acts.

308. Standing.

THE act of standing is accomplished by muscular action, and is the vertical position of equilibrium of the body, in which a line drawn from the centre of gravity of the body falls within the area of both feet placed upon the ground. In the military attitude, the muscles act in two directions—(1) To fix the jointed body, as it were, into one unbending column; and (2) in case of a variation of the equilibrium, to compensate by muscular action for the disturbance of the equilibrium.

The following individual acts occur in standing :—

1. *The fixation of the head upon the vertebral column.* The occiput may be moved in various directions upon the atlas, as in the acts of *nodding*. As the long arm of the lever lies in front of the atlas, necessarily when the muscles of the back of the neck relax, as in sleep, or death, the chin falls upon the breast. The strong neck muscles, which pull from the vertebral column upon the occiput, fix the head in a firm position on the vertebral column.

A nodding movement obliquely forwards and to the side is also possible (L. Gerlach).

The chief rotatory movement of the head on a vertical axis occurs round the odontoid process of the axis. The articular surfaces on the pedicles and part of the bodies of the 1st and 2nd vertebræ are convex towards each other in the middle, becoming somewhat lower in front and behind, so that the head is highest in the erect posture. Hence, when the head is greatly rotated, compression of the medulla oblongata is prevented (Henke). In standing, these muscles do not require to be fixed by muscular action, as no rotation can take place when the neck muscles are at rest.

2. The *vertebral column itself must be fixed*, especially where it is most mobile, *i.e.*, in the cervical and lumbar regions. This is brought about by the strong muscles situate in these regions—*e.g.*, the cervical spinal muscles, *Extensor dorsi communis*, and *Quadratus lumborum*.

Mobility of the Vertebræ.—The least movable vertebræ are the 3rd to the 6th dorsal: the sacrum is quite immovable. For a certain length of the column, the mobility depends on (a) the number and height of the interarticular fibro-cartilages. They are most numerous in the neck, thickest in the lumbar region, and relatively also in the lower cervical region. They permit movement to take place in every direction.

Collectively the interarticular discs form one-fourth of the height of the whole vertebral column. They are compressed somewhat by the pressure of the body; hence, the body is longest, in the morning and after lying in the horizontal position. The smaller periphery of the bodies of the cervical vertebræ favours the mobility of these vertebræ, compared with the larger lower ones. (b) The position of the processes also influences greatly the mobility. The strongly depressed spines of the dorsal region hinder hyperextension. The articular processes on the cervical vertebræ are so placed that their surfaces look obliquely from before and upwards, backwards and downwards; this permits relatively free movement, rotation, lateral and nodding movements. In the dorsal region, the articular surfaces are directed vertically and directly to the front, the lower directly backwards; in the lumbar region, the position of the articular processes is almost completely vertical and antero-posterior. In bending backwards as far as possible, the most mobile parts of the column are the lower cervical vertebræ, the 11th dorsal to the 2nd lumbar and the lower two lumbar vertebræ (E. H. Weber.)

3. The *centre of gravity* of the head, trunk, and arms, when fixed as above, lies in front of the tenth dorsal vertebra. It lies further forward, in a horizontal plane passing through the xiphoid process (Weber), the greater the distension of the abdomen by food, fat, or pregnancy. A line drawn vertically downwards from the centre of gravity, passes *behind* the line uniting both hip joints. Hence, the trunk would fall backwards on the hip joint, were it not prevented, partly by ligaments and partly by muscles. The former are represented by the ileofemoral band and the anterior tense layer of the fascia lata. As ligaments alone, however, never resist permanent traction, they are aided, especially

by the ileopsoas muscle inserted into the small trochanter, and in part also, by the rectus femoris. Lateral movement at the hip joint, whereby the one limb must be abducted and the other adducted, is prevented especially by the large mass of the glutei. When the leg is extended, the ileofemoral ligament, aided by the fascia lata, prevents adduction.

4. The rigid part of the body, head, and trunk, with the arms and the legs, whose centre of gravity lies lower and only a little in front, so that the vertical line drawn downwards intersects a line connecting the posterior surfaces of the knee joints, must now be fixed at the knee joint. Falling backwards is prevented by a slight action of the quadriceps femoris, aided by the tension of the fascia lata. Indirectly it is aided also by the ileofemoral ligament. Lateral movement of the knee is prevented by the disposition of the strong lateral ligaments. Rotation cannot take place at the knee joint in the extended position (§ 305, I., 3).

5. A line drawn downwards from the centre of gravity of the whole body, which lies in the promontory, falls slightly in front of a line between the two ankle joints. Hence, the body would fall *forward* on the latter joint. This is prevented especially by the muscles of the calf, aided by the muscles of the deep layer of the leg (tibialis posticus, flexors of the toes, peroneus longus et brevis).

Other factors:—(a) As the long axis of the foot forms with the leg an angle of 50°, falling forward can only occur after the feet are in a position more nearly parallel with their long axis. (b) The form of the articular surfaces helps, as the anterior broad part of the astragalus must be pressed between the two malleoli. The latter mechanism cannot be of much importance.

6. The metatarsus and phalanges are united by tense ligaments to form the arch of the foot, which touches the ground at three points—tuber calcanei (heel), the head of the first metatarsal bone (ball of the great toe), and of the fifth toe. Between the latter two points, the heads of the metatarsal bones also form points of supports. The weight of the body is transmitted to the highest part of the arch of the foot, the caput tali. The arching of the foot is fixed only by ligaments. The toes play no part in standing, although, when moved by their muscles, they greatly aid the balancing of the body. The maintenance of the erect attitude fatigues one more rapidly than walking.

309. Sitting:

Sitting is that position of equilibrium whereby the body is supported on the tubera ischii, on which a to and fro movement may take place (H. v. Meyer). The head and trunk together are made rigid to form

an immovable column, as in standing. We may distinguish: 1. The *forward posture*, in which the line of gravity passes in front of the tubera ischii; the body being supported either against a fixed object, *e.g.*, by means of the arm on a table or against the upper surface of the thigh. 2. The *backward posture*, in which the line of gravity falls behind the tubera. A person is prevented from falling backward either by leaning on a support, or by the counter-weight of the legs kept extended by muscular action, whereby the sacrum forms an additional point of support, while the trunk is fixed on the thigh by the ileopsoas and rectus femoris, the leg being kept extended by the extensor quadriceps. Usually the centre of gravity is so placed, that the heel also acts as a point of support. The latter sitting posture is of course not suited for resting the muscles of the lower limbs. 3. When "*sitting erect*" the line of gravity falls between the tubera themselves. The muscles of the legs are relaxed, the rigid trunk only requires to be balanced by slight muscular action. Usually the balancing of the head is sufficient to maintain the equilibrium.

310. Walking, Running.

By the term walking is understood progression in a forward horizontal direction with the least possible muscular exertion, due to the alternate activity of the two legs. The following facts have been determined by the researches of W. & Ed. Weber, v. Meyer, Marey, and others:—

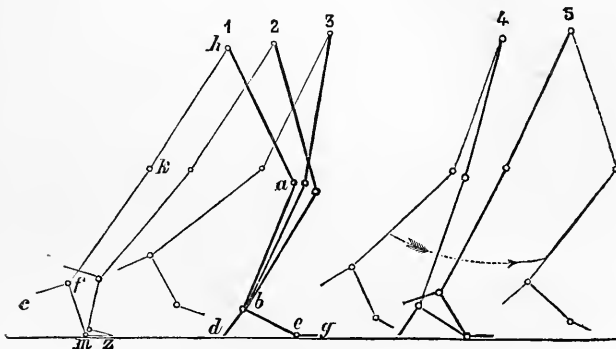

Fig. 260.

Phases of walking—The thick lines represent the active, the thin the passive leg; *h*, the hip joint; *k*, *a*, knee; *f*, *b*, ankle; *c*, *d*, heel; *m*, *e*, ball of the tarsometatarsal joints; *z*, *g*, point of great toe.

In walking, the legs are active alternately; while one—the "supporting" or "active" leg—carries the trunk, the other is "inactive"

or "passive." Each leg is alternately in an active and a passive phase. Walking may be divided into the following movements:—

I. Act (Fig. 260, 2).—The *active* leg is vertical, slightly flexed at the knee, and it alone supports the centre of gravity of the body. The passive leg is completely extended, and touches the ground only with the tip of the great toe (*z*). This position of the leg corresponds to a right-angled triangle, in which the active leg and the ground form two sides, while the passive leg is the hypotenuse.

II. Act.—For the forward movement of the trunk, the active leg is inclined slightly from its vertical position to an oblique and more forward (hypotenuse) position (3). In order that the trunk may remain at the same height, it is necessary that the active leg be lengthened. This is accomplished by completely extending the knee (3, 4, 5), as well as by lifting the heel from the ground (4, 5), so that the foot rests on the balls on the heads of the metatarsal bones, and, lastly, by elevating it on the point of the great toe (2, thin line). *During* the extension and forward movement of the active leg, the tips of the toes of the passive leg have left the ground (3). It is slightly flexed at the knee joint (owing to the shortening), it performs a "pendulum-like movement" (4, 5), whereby its foot is moved as far in front of the active leg as it was formerly behind it. The foot is then placed flat upon the ground (1, 2, thick lines); the centre of gravity is now transferred to this active leg, which, at the same time, is slightly flexed at the knee, and placed vertically. The first act is then repeated.

Simultaneous Movements of the Trunk.—During walking, the trunk performs certain characteristic movements. (1) It leans every time towards the active leg, owing to the traction of the glutei and the tensor fasciæ latae, so that the centre of gravity is moved, which in short, heavy persons with a broad pelvis leads to their "waddling" gait. (2) The trunk, especially during rapid walking, is inclined slightly forward to overcome the resistance of the air. (3) During the "pendulum-like action," the trunk rotates slightly on the head of the active femur. This rotation is compensated, especially in rapid walking, by the arm of the same side as the oscillating leg swinging in the opposite direction, while that on the other side, at the same time swings in the same direction as the oscillating limb.

Modifying Conditions: 1. *The Duration of the Step*.—As the rapidity of the vibration of a pendulum (leg) depends upon its length, it is evident that each individual, according to the length of his legs, must have a certain natural rate of walking. The "*duration of a step*" depends also upon the time during which both feet touch the ground simultaneously, which, of course, can be altered voluntarily. When "walking rapidly" the time = 0—*i.e.*, at the same moment in which the active leg reaches the ground, the passive leg is raised. 2. *The Length of the Step*.—Usually about 6–7 decimetres [23–27 inches]

(Vierordt) must be greater, the more the length of the hypotenuse of the passive leg exceeds the cathetus of the active one. Hence, during a long step, the active leg is greatly shortened (by flexion of the knee), so that the trunk is pulled downwards. Similarly, long legs can make longer steps.

According to Marey and others, the pendulum-movement of the passive leg is not a true pendulum-movement, because its movement, owing to muscular action, is of more uniform rapidity. During the pendulum-movement of the whole limb, the leg vibrates for itself at the knee joint (Lucae, H. Vierordt).

Fixation of the Femur.—According to Ed. and W. Weber, the head of the femur of the passive leg is fixed in its socket chiefly by the atmospheric pressure, so that no muscular action is necessary for carrying the whole limb. If all the muscles and the capsule be divided, the head of the femur still remains in the cotyloid cavity. Rose refers this condition not to the action of the atmospheric pressure, but to two adhesion surfaces united by means of synovia. The experiments of Aeby show, that not only the weight of the limb is supported by the atmospheric pressure, but that the latter can support several times this weight. When traction is exerted on the limb, the margins of the cotyloid ligament of the cotyloid cavity are applied like a valve tightly to the margin of the cartilage of the head of the femur. According to the Brothers Weber, the leg falls from its socket, as soon as air is admitted by making a perforation into the articular cavity.

The pressure upon the sole of the foot in walking is distributed in the following manner:—The supporting leg always presses more strongly on the ground than the other; the longer the step the greater the pressure. The heel receives the maximum of pressure sooner than the point of the foot (Carlet).

Running is distinguished from rapid walking by the fact that, at a particular moment, both legs do not touch the ground, so that the body is raised in the air. The active leg, as it is forcibly extended from a flexed position, gives the body the necessary impetus.

Pathological.—Variations of the walking movements depend primarily upon diseases of bones, ligaments, muscles, and tendons, and also upon affections of the motor nerves. The effect of sensory nerves and the reflex mechanism of the spinal cord, and also of the muscular sense on walking, are stated in §§ 355, 360, 430.

311. Comparative.

In **mammals**, standing is much more easy, as they have four supporting surfaces. The springing animals have a sitting attitude, while the tail is often used as a support (kangaroo, squirrel). In **birds**, there is a mechanical arrangement by which, while perching, the tendons are flexed—hence, a bird while sleeping can still retain its hold (Cuvier). In the stork and crane which stand for a long time on one leg, this act is unaccompanied by muscular action, as the tibia is fixed by means of a process which fits into a depression of the articular surface of the femur.

In **walking**, we distinguish in mammals the *step* (le pas)—the four feet are generally moved in four tempo, and usually diagonally—*e.g.*, in the horse right fore, left hind; left fore, right hind. [The camel is an exception—it moves the fore and hind limbs simultaneously on each side.] In **trotting**, this movement is accelerated, the two limbs in a diagonal direction lift together, so that only

two hoof-sounds are heard; while, at the same time, the body is raised more in the air. During the interval between two hoof-beats, the body is free in the air, all the limbs having left the ground. Strictly speaking, the fore limb leaves the ground slightly sooner than the hind one. The gallop—When a (right) galloping horse moves in the air, the upper part of its body is fairly horizontal; when it touches the ground, the left hind foot is the first to touch the ground. Shortly thereafter, the left fore and right hind foot touch the ground, while the right fore leg has not yet reached the ground and is directed forward. The upper part of the body still retains its horizontal direction. When, however, a few moments thereafter, the left hind leg again leaves the ground, it is higher than the fore leg—simultaneously the right fore leg is thrown forward and lower, while the right hind and left fore leg are stretched to the extreme. Immediately thereafter these limbs leave the ground, while the hind limb, so far overtakes the fore limb, that it comes to lie higher than the latter. The body, therefore, is projected forwards and downwards until the right fore limb, which alone touches the ground, actively contracts and again raises the body from the ground. When this happens, the horse again floats in the air, its body being directed horizontally. The long axis of the horse's body in galloping is placed obliquely to the direction of movement, and forming a right angle. In forced galloping (*la carrière*), which is really a springing movement, the right hind leg and left fore leg do not touch the ground at the same time, but the former does so sooner.

The *amble* is a modification of the step, which consists in this, that both feet on the *same* side move at the same time or shortly after each other (camel, giraffe, elephant).

Marey attached compressible ampullæ under the hoof of a horse, connecting them with registering apparatus, and thus accurately registered the time-relations of each act. Muybridge photographed the actions of a horse and the different phases of the movement.

Swimming is an acquired art in man. The specific gravity of the body is slightly greater than that of ordinary water, but slightly lighter than that of sea water. When lying quietly on the back, so that only the mouth and nose are at last above the water, very slight movements of the hands are necessary to keep a person from sinking. In this position, progression can be accomplished by extending and adducting the legs, while the movement is accelerated by rudder-like movements of the arms. Swimming belly downwards is more difficult, because the head, being held above the water, makes the body specifically heavier. The forward movement and the act of supporting the body in the water consist of three acts:—*First*, horizontal, rudder-like, movements of the extended arms from before backwards, until they reach the horizontal position (forward movement); *second*, pressure of the arms downward, with subsequent adduction of the elbow joint to the body (elevation of the body), together with retraction of the extended legs; *third*, projection of the arms, now brought together, and at the same time extension and adduction of the legs obliquely backwards and downwards, thus causing elevation of the body as well as a forward movement. Too rapid movements cause fatigue, while the respirations must be carefully regulated.

Many **land mammals**, whose body is specifically lighter than water, can swim, especially with the aid of their hind limbs, while at the same time, all the legs being directed downwards, and being specifically the heaviest part of the body, keep the trunk in the normal position.

Fishes chiefly use their tail fin as a motor organ, which is moved by powerful lateral muscles. When the tail is suddenly extended, it presses upon the water and displaces it. Some fish, as the salmon, can lift their body out of the water by a blow of their tail fin. The dorsal and anal fins enable the animal to preserve the erect position. The pectoral and abdominal fins corresponding to the extremities execute slight movements, especially upwards and downwards, which are

greater during sleep. The *swimming bladder* is the homologue of the lung, and is used for hydrostatic purposes in some fishes, and as an auxiliary respiratory organ in others—*e.g.*, the *dipnoi* (§ 140). It is absent or rudimentary in the *cyclostomata*. In *swimming birds*, the body is specifically very much lighter than the water, while their feathers are lubricated by the oily secretion of the *coccygeal glands* (§ 291). Their feet are usually webbed.

Flight.—*Bats* and their allies are the only flying mammals. The bones of the upper limb and phalanges are greatly elongated, and between these and the elongated hind limb (except the foot) there is stretched a thin membrane. The membrane is moved by the powerful pectoral muscles. The flying squirrel has only a duplicature of the skin stretched between the large bones of the extremities, which serves as a parachute when the animals spring. In *birds*, the body is specifically very light; numerous air-sacs in the chest and belly communicate with the lungs, and with the cavities of most of the bones (§ 140). The modified upper extremities are supported by the coracoid bone and the united clavicles or *furculum*, and are moved by the powerful pectoral muscles attached to the keeled sternum.

Voice and Speech.

312. Physical Considerations.

THE blast of expired air—and under certain circumstances, the inspiratory blast also—is employed to throw the tense vocal cords into a state of regular vibration, whereby a sound is produced. The sound so produced is the human voice.

The **true vocal cords** are really elastic membranous reeds. If a blast of air be forcibly driven upwards through the partially closed glottis, the vocal cords are pushed asunder, as the elastic tension of the air overcomes the resistance of the cords. After the escape of the air from below, the cords rapidly return to their former position, and are again pushed asunder, and caused to vibrate.

1. Thus, when a membrane vibrates, the air must be alternately condensed and rarefied. The condensation and rarefaction are the chief cause of the tone or note, as in the siren, not so much the membranes themselves (*v. Helmholtz*).

2. The "*air-tube*" or *porte vente*, conducting the air to the membranes is in man the lower portion of the larynx, the trachea, and the whole bronchial system; the *bellows* is represented by the chest and lungs, which are forcibly diminished in size by the expiratory muscles.

3. The cavities which lie above the membranes constitute "*resonators*," and consist of the upper part of the larynx, pharynx, and also of the cavities of the nose and mouth, arranged, as it were, in two stories, the one over the other, which can be closed alternately.

The **pitch of the tone** produced by a membranous apparatus depends upon the following factors:—

(a) On the *length* of the elastic membranes or plates. The pitch is inversely proportional to the length of the elastic membrane, *i.e.*, the shorter the membrane the higher the pitch, or the greater the number of vibrations per second. Hence, the pitch of a child's vocal cords (shorter) is higher than that of an adult.

(b) The pitch of the tone is directly proportional to the square root of the amount of the elasticity of the elastic membrane. In membranous reeds, and also with silk, it is directly proportional to the square root of the extending weight, which in the case of the larynx, is the force of the muscles rendering the cords tense.

(c) The tone of membranous reeds is not only *strengthened by a more powerful blast*, as the amplitude of the vibrations is increased, but the *pitch of the tone may also be raised* at the same time, because, owing to the great amplitude of the vibration, the mean tension of the elastic membrane is increased (Johannes Müller).

(d) The supra-laryngeal cavities, which act as *resonators*, are also inflated when the larynx is in action, so that the tone produced by these cavities is added to, and blended with, the sound of the elastic membranes, whereby certain partial tones of the latter are strengthened (§ 415). The characteristic timbre of the voice largely depends upon the form of the resonators.

(e) When vocalising, the strongest resonance takes place in the *air-tubes*, as they contain compressed air. It causes the vocal fremitus which is audible on placing the ear over the chest (§ 117, 6).

(f) *Narrowing or dilating* the glottis has no effect on the pitch of the tone, only with a wide glottis, much more air must be driven through it, which of course greatly increases the work of the thorax.

313. Arrangement of the Larynx.

I. The Cartilages and Ligaments of the Larynx.—The fundamental part of the larynx consists of the cricoid cartilage, whose small narrow portion is directed forwards and the broad plate backwards. The thyroid cartilage articulates by its inferior cornu with the posterior lateral portion of the cricoid. This permits of the thyroid cartilage rotating upon a horizontal axis directed through both of the articular surfaces, so that the upper margin of the thyroid passes forward and downward, while the joint is so constructed as to permit also of a slight upward, downward, forward, and backward movement of the thyroid upon the cricoid cartilage (Harless, Henle). The triangular *arytenoid* cartilages articulate at some distance from the middle line with oval, saddle-like, articular surfaces placed upon the upper margin of the plate of the cricoid cartilage. The articular surfaces permit two kinds of movements on the part of the arytenoid cartilages: first, *rotation* on their base around their vertical long axis, whereby either the anterior angle or processus vocalis, which is directed forwards, is rotated outwards; while the processus muscularis, which is directed outwards, and projects over the margin of the cricoid cartilage, is rotated backwards and inwards, or conversely. Further, the arytenoids may be slightly displaced upon their bases either outwards or inwards.

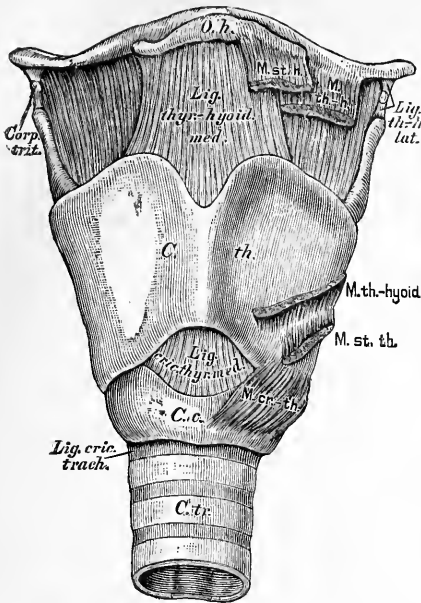

Fig. 261.

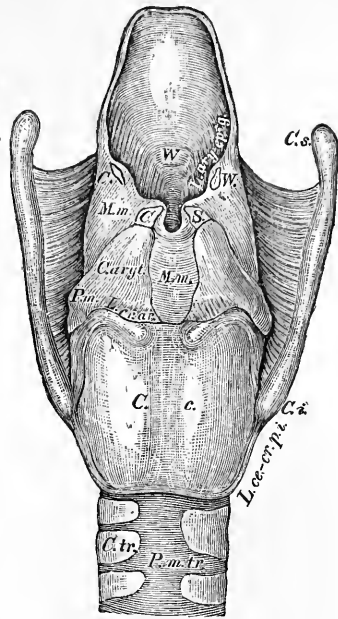

Fig. 262.

The larynx from the front, with the ligaments and the insertions of the muscles—*O. h.*, os hyoideum; *C. th.*, Cartil. thyroidea; *Corp. trit.*, Corpus triticeum; *C. c.*, Cartil. cricoidea; *C. tr.*, Cartil. tracheales; *Lig. thyro-hyoid. med.*, Ligamentum thyreo-hyoideum medium; *Lig. th. h. lat.*, Ligamentum thyreo-hyoideum laterale; *Lig. cric.-thy. med.*, Ligament. crico-thyreoideum medium; *Lig. cric.-trach.*, Ligam. crico-tracheale; *M. st. h.*, Musc. sterno-hyoideus; *M. th. hyoid*, Musc. thyreo-hyoideus; *M. st. th.*, Musc. sterno-thyreoideus; *M. cr. th.*, Musc. crico-thyreoideus.

The larynx from behind after removal of the muscles—*E.*, Epiglottis, with the cushion (*W.*); *L. ar. ep.*, Ligam. ary-epiglotticum; *M. m.*, Membrana mucosa; *C. W.*, Cartil. Wrisbergii; *C. S.*, Cartil. Santorinii; *C. ary.*, Cartil. arytenoidea; *C. c.*, Cartil. cricoidea; *P. m.*, Processus muscularis of Cart. aryten; *L. cr. ar.*, Ligam. crico-aryten; *C. s.*, cornu superius; *C. i.*, Cornu inferius d. Cart. thyroidea; *L. ce. cr. p. i.*, Ligam. kerato-cricoideum. post. inf.; *C. tr.*, Cartil. tracheales; *P. m. tr.*, Pars membranacea tracheæ.

The true vocal cords, or thyro-arytenoid ligaments, are in man about 15 millimetres, and in woman 11 millimetres in length, and consist of numerous elastic fibres. They arise close to each other from near the middle of the inner angle of the thyroid cartilage, and are inserted, each into the anterior angle or processus vocalis of the arytenoid cartilages. The *ventricles of Morgagni* permit free vibration of the true vocal cords, and separate them from the upper or false cords, which consist of folds of mucous membrane. The false vocal cords are not concerned in

phonation, but the secretion of their numerous mucous glands moistens the true vocal cords.

The obliquely directed under surface of the vocal cords causes the cords to come together very easily when the glottis is narrow during respiration (e.g., in sobbing), while the closure may be made more secure by respiration. The opposite is the condition of the false vocal cords, which, when they touch, are easily separated during inspiration; while, during expiration, owing to the dilatation of the ventricles of Morgagni, they easily come together and close (Wyllie, L. Brunton and Cash).

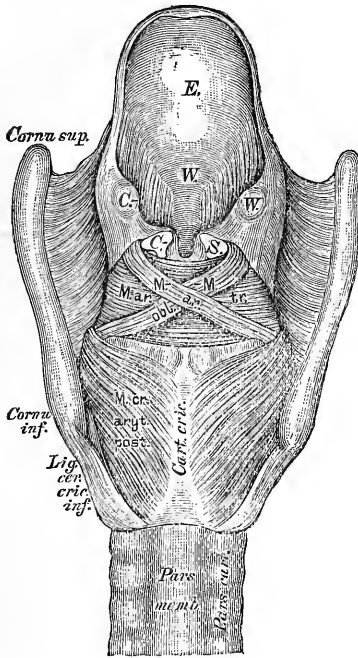

Fig. 263.

Larynx from behind with its muscles—*E.*, Epiglottis, with the cushion (*W.*); *C. W.*, Cartil. Wisbergii; *C. S.*, Cartil. Santoriniana; *C. c.*, Cartil. cricoidea. Cornu sup.—Cornu inf. Cartilaginis thyroideæ; *M. ar. tr.*, Musculus arytenoideus transversus; *Mm. ar. obl.*, Musculi arytenoidei obliqui; *M. cr. ar. post.*, Musculus crico-arytenoideus posticus; *Pars cart.*, Pars cartilaginea; *Pars memb.*, pars membranacea tracheæ.

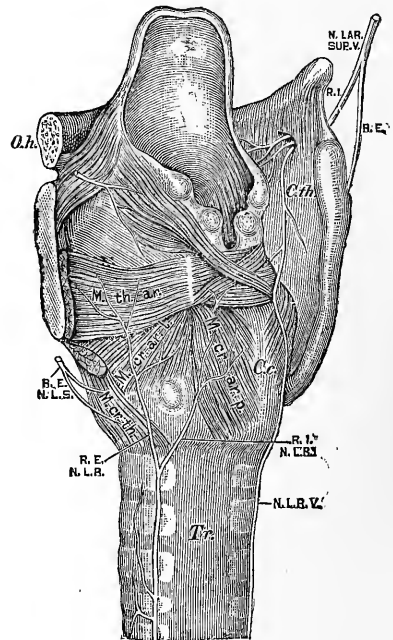

Fig. 264.

The nerves of the larynx—*O. h.*, Os hyoideum; *C. th.*, Cartil. thyroidea; *C. c.*, Cartil. cricoidea; *Tr.*, Trachea; *M. th. ar.*, Musculus thyreo-arytenoideus; *M. cr. ar. p.*, Musculus crico-arytenoideus posticus; *M. cr. ar. l.*, Musculus crico-aryten. lateralis; *M. cr. th.*, Musculus crico-thyreoideus; *N. lar. sup. v.*, Nervus laryngeus superior nervi vagi; *R. I.*, Ramus internus; *R. E.*, Ramus externus; *N. lar. rec. v.*, Nervus laryngeus recurrens vagi; *R. I. N. L. R.*, Ramus internus; *R. E. N. L. R.*, Ramus externus nervi laryngei recurrentis vagi.

II. Action of the Laryngeal Muscles.—These muscles have a double function :—1. One connected with *respiration*, in as far as the glottis is widened and narrowed alternately during respiration ; further, when the glottis is firmly closed by these muscles, the entrance of foreign substances into the larynx is prevented. The glottis is closed immediately before the act of coughing (p. 248). 2. The laryngeal muscles give the vocal cords the proper tension and other conditions for *phonation*.

1. The glottis is dilated by the action of the *posterior crico-arytenoid* muscles. When they contract, they pull both processus musculares of the arytenoid cartilages backwards, downwards, and towards the middle line (Fig. 265), so that the processus vocales (I, I) must go apart and upwards (II, II). Thus, between the vocal cords (*glottis vocalis*), as well as between the inner margins of the arytenoid cartilages, a large triangular space is formed (*glottis respiratoria*), and these spaces are so arranged that their bases come together, so that the aperture between the cords and the arytenoid cartilages has a rhomboidal form. Fig. 265 shows the action of these muscles. The vocal cords, represented by lines converging in front, arise from the anterior angle of the arytenoid

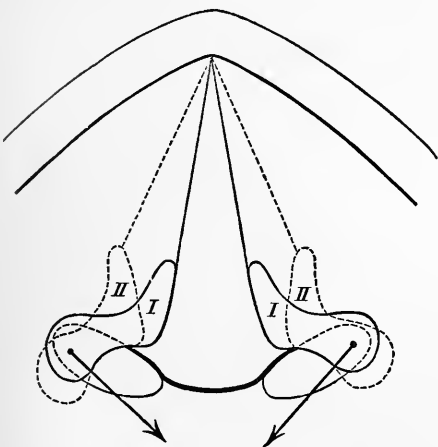

Fig. 265.

Schematic horizontal section of the larynx—
I, Position of the horizontally divided arytenoid cartilages during respiration ; from their anterior processes run the converging vocal cords. The arrows show the line of traction of the *posterior crico-arytenoid* muscles ; II, II, the position of the arytenoid cartilages as a result of this action.

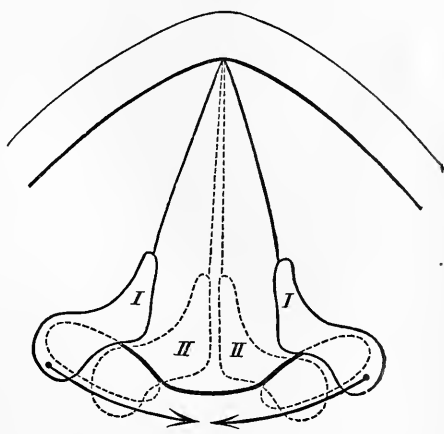

Fig. 266.

Schematic horizontal section through the larynx, to illustrate the action of the *arytenoid muscle*—I, I, position of the arytenoid cartilages during quiet respiration. The arrows indicate the direction of the contraction of the muscle—II, II, the position of the arytenoid cartilages after the *arytenoideus* contracts.

cartilages (I, I). When these cartilages are rotated into the position (II, II), the cords take the position indicated by the dotted lines. The widening of the respiratory portion of the glottis between the arytenoid cartilages is also indicated in the diagram.

Pathological.—When these muscles are paralysed, the widening of the glottis does not take place, and there may be severe dyspnoea during inspiration (Riegel, L. Weber), although the voice is unaffected.

2. The entrance to the glottis is constricted by the *arytenoid muscle* (transverse), which extends transversely between both outer surfaces of the arytenoids along their whole length (Fig. 266). On the posterior surface of this muscle is placed the cross bundles (Fig. 263) of the thyro-aryepiglotticus (or arytaenoidi obliqui); they act like the foregoing. The action of these muscles is indicated in Fig. 266; the arrows point to the line of traction.

Pathological.—Paralysis of this muscle enfeebles the voice and makes it hoarse, as much air escapes between the arytenoid cartilages during phonation.

3. In order that the **vocal cords** be approximated to each other, which occurs during phonation, the processus vocales of the arytenoid cartilages must be closely apposed, whereby they must be rotated inwards and downwards. This result is brought about by the processus

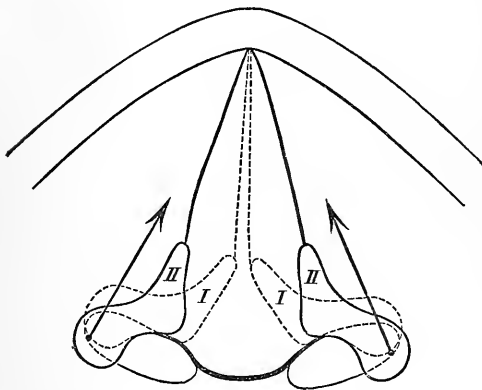

Fig. 267.

Schematic horizontal section of the larynx, to illustrate the closure of the glottis by the *internal thyro-arytenoid muscles*—II, II, position of the arytenoid cartilages during quiet respiration. The arrows indicate the direction of the muscular traction—I, I, position of the arytenoid cartilages after the muscles contract.

angular opening. The action of these muscles is indicated in Fig. 267.

musculares being moved in a forward and upward direction by the *thyro-arytenoid* muscles. These muscles are applied to, and in fact are embedded in, the substance of the elastic vocal cords, and their fibres reach to the external surface of the arytenoid cartilages. When they contract, they rotate these cartilages so that the processus vocales must rotate inwards. The glottis vocalis is thereby narrowed to a mere slit (Fig. 267), whilst the glottis respiratoria remains as a broad triangular opening.

The *lateral crico-arytenoid* muscle is inserted into the anterior margin of the articular surface of the arytenoid cartilage; hence, it can only pull the cartilage forwards (Henle); but some have supposed it can also rotate the arytenoid cartilage in a manner similar to the internal thyro-arytenoids (?), with this difference, that the *processus vocales* do not come so close to each other.

Pathological.—Paralysis of both thyro-arytenoid muscles causes loss of voice.

4. The vocal cords are rendered tense, by their points of attachment being removed from each other by the action of muscles. The chief agents in this action are the *crico-thyroid muscles*, which pull the thyroid cartilage forwards and downwards. At the same time, however, the posterior crico-arytenoids must pull the arytenoid cartilages slightly backwards, and at the same time keep them fixed.

The genio-hyoid and thyro-hyoid, when they contract, pull the thyroid upwards and forwards towards the chin, and also tend to increase the tension of the vocal cords (C. Mayer, Gritzner).

Pathological.—Paralysis of the crico-thyroid causes the voice to become harsh and deep, owing to the vocal cords not being sufficiently tense.

Position during Phonation.—The tension of the vocal cords brought about in this way is of itself not sufficient for phonation. The triangular aperture of the glottis respiratoria between the arytenoid cartilages, produced by the unaided action of the internal thyro-arytenoid muscles (see 3) must be closed by the action of the transverse and oblique arytenoid muscles. The vocal cords themselves must have a concave margin, which is obtained through the action of the crico-thyroids and posterior crico-arytenoids, so that the glottis vocalis presents the appearance of a myrtle leaf (Henle), while the rima glottidis has the form of a linear slit (Fig. 271). The contraction of the internal thyro-arytenoid converts the concave margin of the vocal cords into a straight margin. This muscle adjusts the delicate variations of tension of the vocal cords themselves, causing more especially such variations as are necessary for the production of tones of slightly different pitch. As these muscles come close to the margin of the cords, and are securely woven as it were amongst the elastic fibres of which the cords consist, they are specially adapted for the above-mentioned purpose. When the muscles contract, they give the necessary resistance to the cords, thus favouring their vibration. As some of the muscular fibres end in the elastic fibres of the cords, these fibres when they contract, can render certain parts of the cords more tense than others, and thus favour the modifications in the formation of the tones. The *coarser* variations in the tension of the

vocal cords are produced by the separation of the thyroid from the arytenoid cartilages, while the *finer* variations of tension are produced by the internal thyro-arytenoid muscles. The value of the elastic tissue of the cords does not depend so much upon its extensibility, as upon its property of shortening without forming folds and creases (Henle).

Pathological.—In paralysis of these muscles, the voice can only be produced by forcible expiration, as much air escapes through the glottis; the tones are at the same time deep and impure. Paralysis of the muscle of one side causes flapping of the vocal cord on that side (Gerhardt).

5. The relaxation of the vocal cords occurs spontaneously when the stretching forces cease to act; the elasticity of the displaced thyroid and arytenoid cartilages comes into play, and restores them to their original position. The vocal cords are also relaxed by the action of the thyro-arytenoid and lateral crico-arytenoid muscles.

It is evident from the above statements, that *tension of the vocal cords and narrowing of the glottis* are necessary for phonation. The tension is produced by the crico-thyroids and posterior crico-arytenoids; the narrowing of the glottis respiratoria by the arytenoids, transverse and oblique, the glottis vocalis being narrowed by the internal thyro-arytenoids and (? lateral crico-arytenoids), the former muscles causing the cords themselves to become tense.

Nerves (§ 352, 5).—The crico-thyroid is supplied by the superior laryngeal branch of the vagus, which at the same time is the sensory nerve of the mucous membrane of the larynx. All the other intrinsic muscles of the larynx are supplied by the inferior laryngeal.

The mucous membrane of the larynx is richly supplied with elastic fibres, and so is the sub-mucosa. The sub-mucosa is more lax near the entrance to the glottis and in the ventricles of Morgagni, which explains the enormous swelling that sometimes occurs in these parts in œdema glottidis. A thin, clear limiting membrane lies under the epithelium. The *epithelium* is stratified, cylindrical, and ciliated with intervening goblet cells. On the true vocal cords and the anterior surface of the epiglottis, however, this is replaced by stratified squamous epithelium which covers the small papillæ of the mucous membrane. Numerous branched *mucous glands* occur over the cartilages of Wrisberg, the cushion of the epiglottis, and in the ventricles of Morgagni; in other situations, as on the posterior surface of the larynx, the glands are more scattered.

The **blood-vessels** form a dense capillary plexus under the membrana propria of the mucous membrane: under this, however, there are other two strata of blood-vessels. The **lymphatics** form a superficial narrow mesh-work under the blood-capillaries, with a deeper, coarser plexus. The *medullated nerves* have ganglia in their branches, but their mode of termination is unknown. [W. Stirling has described a rich sub-epithelial plexus of medullated nerve-fibres on the anterior surface of the epiglottis, while he finds that there are ganglionic cells in the course of the superior laryngeal nerve.]

Cartilages.—The thyroid, cricoid, and nearly the whole of the arytenoid cartilages consist of *hyaline* cartilage. The two former are prone to ossify. The apex and processus vocalis of the arytenoid cartilages consist of *yellow fibro-cartilage*, and so do all the other cartilages of the larynx.

The larynx grows until about the sixth year, when it rests for a time, but it becomes again much larger at puberty.

314. Investigation of the Organs of Voice —Laryngoscopy.

Historical.—After Bozzini (1807) gave the first impulse towards the investigation of the internal cavities of the body, by illuminating them with the aid of mirrors, Babington (1829) actually observed the glottis in this way. The famous singer, Manuel Garcia (1854) made investigations both on himself and other singers, regarding the movements of the vocal cords, during respiration and phonation. The examination of the larynx by means of the laryngoscope was rendered practicable, chiefly by Türk (1857) and Czermak, the latter observer being the first to use the light of a lamp for the illumination of the larynx. Rhinoscopy was actually first practised by Baumès (1838), but Czermak was the first person who investigated this subject systematically.

The **Laryngoscope** consists of a small mirror fixed to a long handle, at an angle of 125° – 130° (Fig. 268, B). When the mouth is opened, and the tongue drawn forward, the mirror is introduced, as is shown in Fig. 268, A. The position of the mirror must be varied, according to the portion of the larynx we wish to examine; in some cases, the soft palate has to be raised by the back of the mirror, as in the position, *b*. A picture of the part of the larynx examined is formed in the small mirror, the rays of light passing in the direction indicated by the dotted lines from the mirror; they are reflected at the same angle through the mouth into the eye of the observer, who must place himself in the direction of the reflected rays.

The illumination of the larynx is accomplished either by means of direct sun-light or by light from an artificial source, *e.g.*, an ordinary lamp or an oxyhydrogen lime-light. The beam of light impinges upon a *concave mirror* of 15–20 centimetres focus, and 10 centimetres in width, and from its surface the concentrated beam of light is reflected through the mouth of the patient, and directed upon the small mirror held in the back part of the throat. The beam of light is reflected at the same angle towards the larynx by the small throat mirror, so that the larynx is brightly illuminated. The observer has now to direct his eye in the same direction as the illuminating rays, which can be accomplished by having a hole in the centre of the concave mirror through which the observer looks. Practically, however, this is unnecessary; all that is necessary is to fix the concave mirror to the fore-

head by means of a broad elastic band, so that the observer, by looking just under the margin of the concave mirror, can see the picture of the larynx in the small throat mirror (Fig. 269).

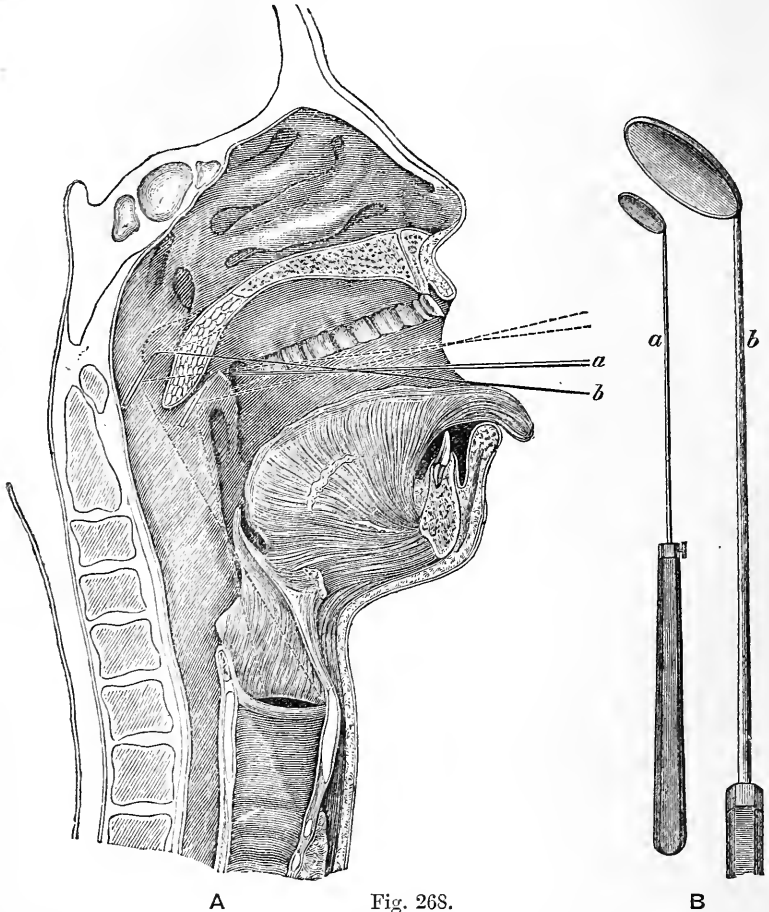

A

Fig. 268.

B

A vertical section through the head and neck, as far as the first dorsal vertebra—*a*, the position of the laryngoscope on observing the posterior part of the glottis, arytenoid cartilages, the upper surface of the posterior wall of the larynx; *b*, its position on observing the anterior angle of the glottis. Large, *b*, and *a*, small laryngoscopic mirrors.

In order to examine the larynx, place the patient immediately in front of you, and cause him to open his mouth and protrude his tongue. A lamp is placed at the side of the head of the patient, and light from this source is reflected from the concave mirror on the observer's forehead, and concentrated upon the laryngoscopic mirror introduced into the back part of the throat of the patient (Fig. 269).

The Picture of the Larynx.—Fig. 270 shows the following structures:—*L*, the root of the tongue, with the ligamentum glosso-epiglotticum

continued from its middle: on each side of the latter are *VV*, the so-called *valleculae*. The *epiglottis* (*E*) appears like an arched upper lip;

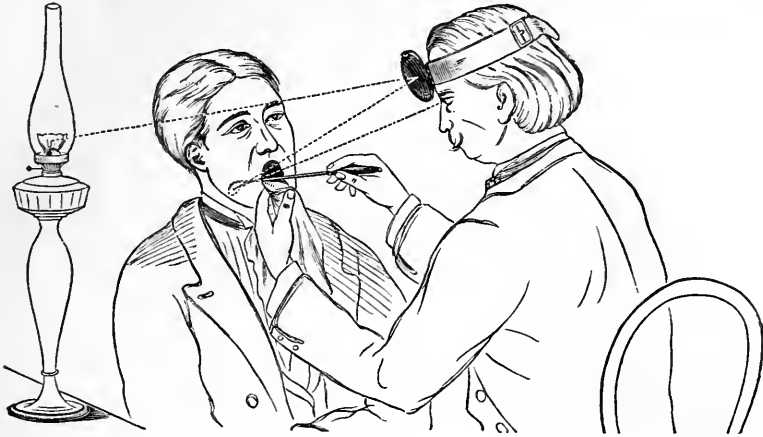

Fig. 269.

Method of examining the larynx.

under it, during normal respiration, the lancet-shaped *glottis* (*R*) and on each side of it the *true vocal cords* (*L. v.*) The length of the vocal cord in a child is 6–8 millimetres—in the female 10–15 millimetres, when they are relaxed, and 15–20 millimetres when tense. In man, the lengths under the same conditions are 15–20 mm. and 20–25 mm. The breadth varies from 2–5 mm. (Schnitzler). On the external side of each vocal cord is the entrance to the *sinus of Morgagni* (*S. M.*) represented as a dark line. Further upwards and more external are (*L. v. s.*) the upper or *false vocal cords*. [The upper or false vocal cords are red, the lower or true, white.] On each side of *P*. are (*S. S.*), the apices of the *cartilages of Santorini*, placed upon the apices of arytenoid cartilages, while immediately behind is the wall of the pharynx, *P*. In the aryteno-epiglottidean fold are (*W. W.*), the *cartilages of Wrisberg*, while outside these are the depressions (*S. p.*), constituting the *Sinus piriformes*.

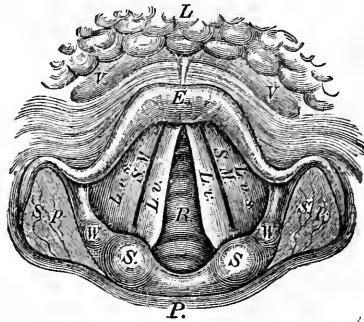

Fig. 270.

The larynx, as seen with the laryngoscope—*L*, tongue; *E*, epiglottis; *V*, vallecula; *R*, glottis; *L. v.*, true vocal cords; *S. M.*, sinus Morgagni; *L. v. s.*, false vocal cords; *P*, position of pharynx; *S*, cartilage of Santorini; *W*, of Wrisberg; *S. p.*, sinus piriformes.

During normal respiration, the glottis (Fig. 270) has the form of a lancet-shaped slit between the bright, yellowish-white vocal cords. If a *deep inspiration* be taken, the glottis is considerably widened (Fig. 272), and if the mirror be favourably adjusted we may see the rings of the trachea, and even the bifurcation of the trachea (Fig. 272).

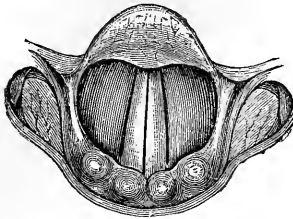

Fig. 271.

Position of the vocal cords on uttering a high note.

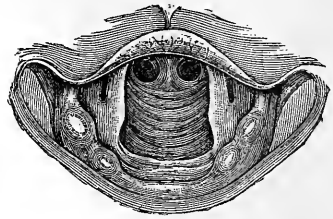

Fig. 272.

Position of the cords during a very deep inspiration. Rings and bifurcation of trachea visible.

If a *high note* be uttered, the glottis is contracted (Fig. 271) to a very narrow slit.

The length of the glottis in man is 23, in woman 17 millimetres, and of this 15.5 and 11.5 respectively belong to the part lying between the vocal cords. When the vocal cords are tense, the corresponding numbers in man are 27.5 (19.5 between the cords), in woman 20 (14) millimetres (Moura).

v. Ziemssen showed that, with the aid of the laryngoscope, fine electrodes may be introduced into the larynx to stimulate its muscles; but the internal laryngeal muscles may also be caused to contract by stimulating the skin externally (Rossbach).

Rhinoscopy.—If a small mirror, fixed to a handle at an angle of 100°–110°, be introduced into the pharynx, as shown in Fig. 273, and if the mirror be directed *upwards*, certain structures are with difficulty rendered visible (Fig. 274). In the middle is the septum narium (*S. n.*), and on each side of it the long, oval large posterior nares (*Ch.*), below this the *soft palate* (*P. m.*), with the pendant *uvula* (*U*). In the posterior nares are the posterior extremities of the lower (*C. i.*), middle (*C. m.*), and upper *turbinated bones* (*C. s.*). At the upper part, a portion of the roof of the pharynx (*O. R.*) is seen, with the arched masses of adenoid tissue lying between the openings of the *Eustachian tubes* (*T. T.*), and called by Luschka the *pharyngeal tonsils*. External to the opening of the Eustachian tube is the *tubular eminence* (*W*), and outside this is the groove of Rosenmüller (*R*) (Schnitzler).

Experiments on the Larynx.—Ferrein (§ 741), and above all, Joh. Müller, made experiments upon the excised larynx. A tracheal tube was tied into the excised human larynx, and air was blown through it, the pressure being measured by means of a mercurial manometer, while various arrangements were adopted for putting the vocal cords on the stretch and for opening or closing the glottis.

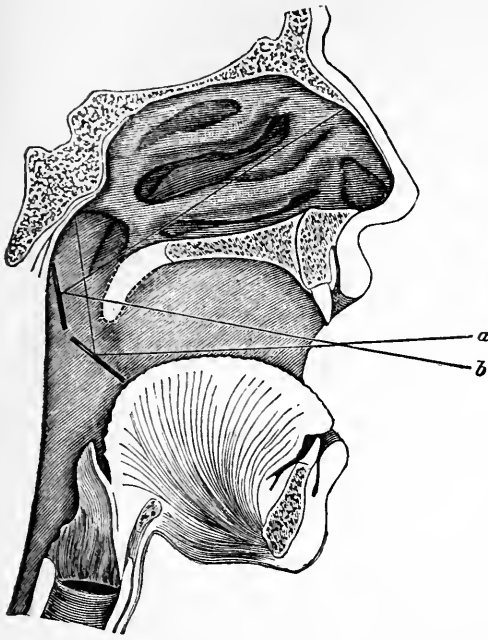

Fig. 273.

Position of the laryngoscopic mirror in rhinoscopy.

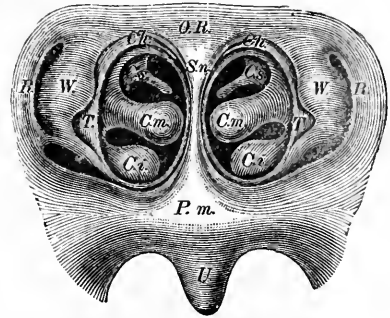

Fig. 274.

The view obtained by moving the mirror—*S. n.*, Septum narium; *C. i.*, *C. m.*, *C. s.*, lower, middle, and upper turbinated bones; *T.*, Eustachian tube; *W.*, tubular eminence; *R.*, groove of Rosenmüller; *P. m.*, soft palate; *O. R.*, roof of pharynx; *U.*, uvula.

315. Conditions influencing the Sound emitted by the Larynx.

The pitch of the note emitted by the larynx depends upon:—

1. *The Tension of the Vocal Cords*, i.e., upon the degree of contraction of the crico-thyroid and posterior crico-arytenoid muscles, and also of the internal thyro-arytenoids (§ 313, II., 4).

2. *The Length of the Vocal Cord*.—(a) Children and females with short vocal cords produce high notes. (b) If the arytenoid cartilages are pressed together by the action of the arytenoid muscles (transverse, and oblique), so that the vocal cords alone can vibrate, while their intercartilaginous portions lying between the *processus vocales* do not, the tone thereby produced is higher (Garcia). In the production of low notes, the vocal cords, as well as margins of the arytenoid cartilages, vibrate. At the same time, the space above the entrance to the glottis is enlarged and the larynx becomes more prominent. (c) Every individual has a certain medium pitch of his voice, which corresponds to the smallest possible tension of the intrinsic muscles of the larynx.

3. *On the Strength of the Blast*.—That the strength of the blast from

below raises the pitch of the tones of the human larynx is shown by the fact that, tones of the highest pitch can only be uttered by powerful expiratory efforts. With tones of *medium* pitch, the pressure of the air in the trachea is 160 mm., with *high* pitch 200 mm., and with *very high* notes 945 mm., and in *whispering* 30 mm., of water (Cagniard-Latour, Grützner). These results were obtained from a tracheal fistula.

Accessory Phenomena.—The following as yet but partially explained phenomena are observed in connection with the production of high notes:—(a) As the pitch of the note rises, the larynx is elevated, partly because the muscles raising it are active, partly because the increased intratracheal pressure so lengthens the trachea, that the larynx is thereby raised; the uvula is raised more and more (Labus). (b) The upper vocal cords approximate to each other more and more, without however coming into contact, or participating in the vibrations. (c) The epiglottis inclines more and more backwards over the glottis.

4. The falsetto voice with its soft timbre and the absence of resonance in the air-tubes (*Pectoral fremitus*) is particularly interesting.

Oertel observed that during the falsetto voice, the vocal cords vibrated so as to form nodes across them, but sometimes there was only one node, so that the free margin of the cord and the basal margin vibrated, being separated from each other by a nodal line (parallel to the margins of the vocal cord). During a high falsetto note, there may be three such nodal lines parallel to each other. The nodal lines are produced probably by a partial contraction of the fibres of the thyro-arytenoid muscle (p. 691), while at the same time, the vocal cords must be reduced to as thin plates as possible, by the action of the crico-thyroid, posterior arytenoid, thyro- and genio-hyoid muscles (Oertel). The form of the glottis is elliptical, while with the chest-voice, the vocal cords are limited by straight surfaces (Jelenffy, Oertel); the air also passes more freely through the larynx.

Oertel also found that during the falsetto voice, the epiglottis is erect. The apices of the arytenoid cartilages are slightly inclined backwards, the whole larynx is larger from before backwards, and narrower from side to side, the aryepiglottidean folds are tense with sharp margins, and the entrance to the ventricles of Morgagni is narrowed. The vocal cords are narrower, the *processus vocales* touch each other. The rotation of the arytenoid cartilages necessary for this, is brought about by the action of the crico-arytenoid alone, while the thyro-arytenoid is to be regarded only as an accessory aid. The pitch of the note is increased solely by increased tension of the vocal cords. In addition, there are a number of transverse and longitudinal *partial vibrations*. During the *chest-voice*, a smaller part of the margin vibrates than in the falsetto voice, so that in the production of the latter, we are conscious of less muscular exertion in the larynx. The uvula is raised to the horizontal position (Labus).

Production of Voice.—In order that voice be produced, the following conditions are necessary:—1. The necessary amount of air is collected

in the chest; 2. the larynx and its parts are fixed in the proper position; 3. air is then forced by an expiratory effort either through the linear chink of the closed glottis, so that the latter is forced open, or at first some air is allowed to pass through the glottis, without producing a sound, but as the blast of air is strengthened the vocal cords are thrown into vibration.

316. Range of the Voice.

The range of the human voice for chest notes is given in the following schema:—

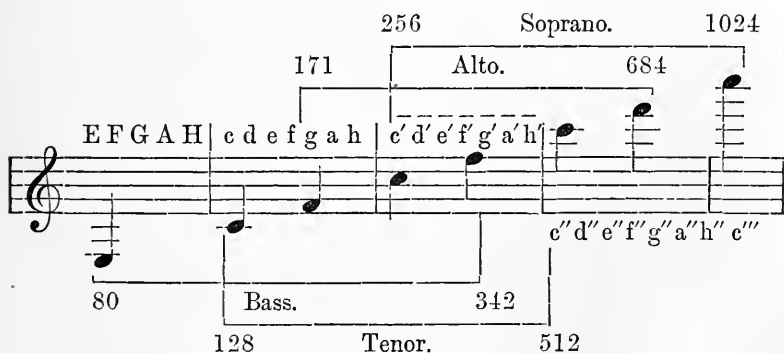

The accompanying figures indicate the number of vibrations per second in the corresponding tone. It is evident that from *c'* to *f'* is common to all voices, nevertheless, they have a different timbre.

The lowest note or tone, which, however, is only occasionally sung by bass singers, is the contra-F, with 42 vibrations—the highest note of the soprano voice is *a'''*, with 1708 vibrations.

Timbre.—The voice of every individual has a peculiar *quality, clang, or timbre*, which depends upon the shape of all the cavities connected with the larynx. In the production of *nasal tones*, the air in the nose is caused to vibrate strongly, so that the entrance to the nares must necessarily be open.

317. Speech—The Vowels.

The motor processes connected with the production of speech occur in the *resonating cavities*, the pharynx, mouth, and nose, and are directed towards the production of musical tones and noises.

Whispering and Audible Speech.—When sounds or noises are produced in the resonating chambers, the larynx being passive, the vox

clandestina, or *whispering*, is produced; when the vocal cords, however, vibrate at the same time, "*audible speech*" is produced. [Whispering, therefore, is speech without voice.] Whispering may be fairly loud, but it requires great exertion—*i.e.*, a great expiratory blast—for its production; hence, it is very fatiguing. It may be performed both with inspiration and expiration, while audible speech is but temporary and indistinct, if it is produced during inspiration. Whispering is caused by the sound produced by the air passing through the moderately contracted rima glottidis, and passing over the obtuse margin of the cord. During the production of *audible sounds*, however, the sharp margins of the vocal cords are directed towards the air, by the position of the processus vocales.

During speech, the *soft palate* is in action; at each word it is raised, while, at the same time, Passavant's transverse band is formed in the pharynx (p. 306). The soft palate is raised highest when *u* and *i* are sounded, then with *o* and *e*, and least with *a*. When sounding *m* and *n* it does not move; it is high (like *n*) during the utterance of the explosives. With *l*, *s*, and especially with the guttural *r*, it exhibits a trembling movement (Gentzen, Falkson).

Speech is composed of vowels and consonants.

Vowels (analysis and artificial formation, § 415).—A. During *whispering*, a vowel is the musical tone produced, either during expiration or inspiration, by the inflated characteristic form of the mouth (Donders), which not only has a definite *pitch*, but also a particular and characteristic *timbre*. The characteristic form of the mouth may be called "*vowel-cavity*."

I. The *pitch* of the vowels may be estimated musically. It is remarkable that the fundamental tone of the "*vowel-cavity*" is nearly constant at different ages and in the sexes. The different capacities of the mouth can be compensated by different sizes of the oral aperture. The *pitch* of the *vowel-cavity* may be estimated by placing a number of vibrating tuning-forks of different *pitch* in front of the mouth, and testing them until we find the one which corresponds with the fundamental tone of the *vowel-cavity*. This is known by the fact that the tone of the tuning-fork is intensified by the *resonance* of the air in the mouth (v. Helmholtz).

According to König, the fundamental tones of the *vowel-cavity* are for

$$U = b, O = b', A = b'', E = b''', I = b''''.$$

If the vowels be whispered in this series, we find at once that their *pitch* rises. The fundamental tone in the production of a vowel may vary within certain limits. This may be shown by giving the mouth the characteristic position and then percussing the cheeks (Auerbach); the sound emitted is that of the vowel, whose *pitch* will vary according to the position of the mouth.

When sounding **A**, the mouth has the form of a funnel widening in front (Fig. 275, A). The tongue lies in the floor of the mouth, and the lips are wide open. The soft palate is moderately raised (Czermak). It is more elevated successively with **O**, **E**, **U**, **I**. The hyoid bone appears as if at rest, but the larynx is slightly raised. It is higher than with **U**, but lower than with **I**.

If we sound **A** to **I**, the larynx and the hyoid bone retain their *relative* position, but both are raised. In passing from **A** to **U**, the larynx is depressed as far as possible. The hyoid bone passes slightly forward (Brücke). When sounding **A**, the space between the larynx, posterior wall of the pharynx, soft palate, and the root of the tongue, is only moderately wide; it becomes wider with **E**, and especially with **I** (Purkinje), but it is smallest with **U**.

When sounding **U** (Fig. 275), the form of the cavity of the mouth is like that of a capacious flask with a short, narrow neck. The whole resonance apparatus is then longest. The lips are protruded as far as possible—they are arrayed in folds and closed, leaving only a small opening. The larynx is depressed as far as possible, while the root of the tongue is approximated to the posterior margin of the palatine arch.

When sounding **O**, the mouth, as in **U**, is like a wide-bellied flask with a short neck, but the latter is shorter and wider as the lips are nearer to the teeth. The larynx is slightly higher than with **U**, while the resonance chambers also are shorter.

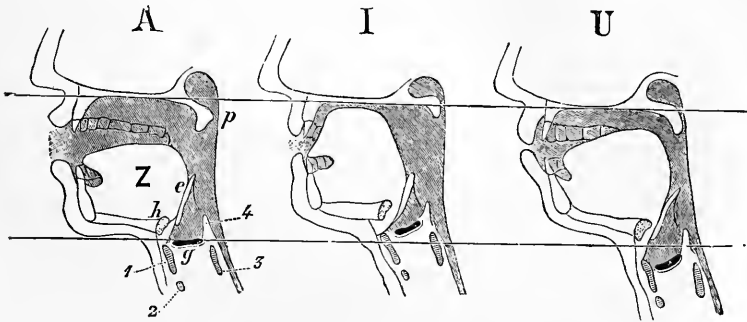

Fig. 275.

Section of the parts concerned in phonation—**Z**, tongue; **p**, soft palate; **e**, epiglottis; **g**, glottis; **h**, hyoid bone; 1, thyroid; 2, 3, cricoid; 4, arytenoid cartilage.

When sounding **I** (Fig. 275), the cavity of the mouth, at the posterior part, is in the form of a small-bellied flask with a long narrow neck, of which the belly has the fundamental tone, **f**, the neck that of **d'''** (v. Helmholtz). The resonating chambers are shortest, as the larynx is

raised as much as possible, while the mouth, owing to the retraction of the lips, is bounded in front by the teeth. The cavity between the hard palate and the back of the tongue is exceedingly narrow, there being only a median narrow slit. Hence, the air can only enter with a clear piping noise, which sets even the vertex of the skull in vibration, and, when the ears are stopped, the sound seems very shrill. When the larynx is depressed and the lips protruded, as for sounding U, I cannot be sounded.

When sounding E, which stands next to I, the cavity has also the form of a flask with a small belly (fundamental tone, f') and with a long, narrow neck (fundamental tone, b'') (v. Helmholtz). The neck is wider, so that it does not give rising to a piping noise. The larynx is slightly lower than for I, but not so high as for A.

Fundamentally there are only *three primary* vowels (Brücke)—I, A, U, the others and the so-called diphthongs standing between them (Brücke).

Diphthongs occur when, *during vocalisation*, we pass from the position of one vowel into that of another. Distinct diphthongs are sounded only on passing from one vowel with the mouth wide open to one with the mouth narrow; during the converse process, the vowels appear to our ear to be separate (Brücke).

II. *Timbre or Clang-Tint*.—Besides its pitch, every vowel has a special timbre, quality, or clang-tint.

The vocal timbre of U (whispering) has, in addition to its fundamental tone, b, a deep, piping timbre. The timbre depends upon the number and pitch of the *partials or overtones* of the vowel sound (§ 415).

Nasal Timbre.—The timbre is modified in a special manner, when the vowels are spoken with a "nasal" twang, which is largely the case in the French language. The nasal timbre is produced by the soft palate not cutting off the nasal cavity completely, which happens every time when a *pure* vowel is sounded, so that the air in the nasal cavity is thrown into sympathetic vibration. When a vowel is spoken with a nasal timbre, air passes out of the nose and mouth simultaneously, while with a pure vowel sound, it passes out only through the mouth.

When sounding a pure vowel (non-nasal), the shutting off of the nasal cavity is so complete, that it requires an artificial pressure of 30-100 mm. of mercury to overcome it (Hartmann).

The vowels, a, ä (æ), ö (œ), o, e, are used with a nasal timbre—a nasal i does not occur in any language. Certainly it is very difficult to sound it thus, because, when sounding i, the mouth is so narrow that when the passage to the nose is open, the air passes almost completely

through the latter, whilst the small amount passing through the mouth scarcely suffices to produce a sound.

In sounding vowels, we must observe if they are sounded through a previously closed glottis, as is done in the German language in all words beginning with a vowel (*spiritus lenis*). The glottis, however, may be previously opened with a preliminary breath, followed by the vowel sound; we obtain the aspirate vowel (*spiritus asper* of the Greeks).

B. If the vowels are sounded in an audible tone, *i.e.*, along with the sound from the larynx, the fundamental tone of the vocal cavity strengthens in a characteristic manner the corresponding partial tones present in the laryngeal sound (Wheatstone, v. Helmholtz).

318. The Consonants.

The consonants are noises which are produced at certain parts of the resonance chambers. [As their name denotes, they can only be sounded in conjunction with a vowel.]

Classification.—The most obvious classification is according to—
(I.) Their *acoustic properties*, so that they are divided into—(1) *Liquid* consonants, *i.e.*, such as are appreciable without a vowel (m, n, l, r, s)—
(2) *Mutes*, including all the others, which cannot be distinctly heard without an accompanying vowel. (II.) According to their *mechanism of formation*, as well as the type of the organ of speech, by which they are produced. They are divided into—

1. **Explosives.**—Their enunciation is accompanied by a kind of bursting open of an obstacle, or an explosion, occasioned by the confined and compressed air which causes a stronger or weaker noise; or, conversely, the current of air is suddenly *interrupted*, while, at the same time, the nasal cavities are cut off by the soft palate.

2. **Aspirates**, in which one part of the canal is constricted or stopped, so that the air rushes out through the constriction, causing a faint whistling noise. (The nasal cavity is cut off.) In uttering L, which is closely related to the aspirates, but differs from them in that the narrow passage for the rush of air is not in the middle, but at both sides of the middle of the closed part. (The nasal cavity is shut off.)

3. **Vibratives**, which are produced by air being forced through a narrow portion of the canal, so that the margins of the narrow tube are set in vibration. (The nasal cavity is shut off.)

4. **Resonants** (also called nasals or semi-vowels).—The nasal cavity is completely free, while the vocal canal is completely closed in the front part of the oral channel. According to the position of the

obstruction in the oral cavity, the air in a larger or smaller portion of the mouth is thrown into sympathetic vibration.

We may also classify them according to the *position in which they are produced*—the “articulation positions” of Brücke. These are:—

- A. Between both lips ;
- B. Between the tongue and the hard palate ;
- C. Between the tongue and the soft palate ;
- D. Between the two true vocal cords.

A. Consonants of the First Articulation Position.

1. **Explosive Labials.**—**b**, the voice is sounded before the slight explosion occurs; **p**, the voice is sounded after the much stronger explosion has taken place (Kempelen). [The former is spoken of as “voiced” and the latter as “breathed.”]

2. **Aspirate Labials.**—**f**, between the upper incisor teeth and the lower lip (labiodental). It is absent in all true slavic words (Purkiñe); **v**, between both lips (labial); **w** is formed when the mouth is in the position for **f**, but instead of merely forcing in the air, the voice is sounded at the same time. Really there are two different **w**—one corresponding to the labial **f**, as in *würde*, and the labiodental, *e.g.*, *quelle* (Brücke).

3. **Vibrative Labials.**—The burring sound, emitted by grooms, but which is not used in civilised language.

4. **Resonant Labials.**—**m** is formed essentially by sounding the voice whereby the air, in the mouth and nose, is thrown into sympathetic vibration [“voiced.”]

B. Consonants of the Second Articulation Position.

1. The **explosives**, when enunciated sharply and without the voice, are **T** hard (also **dt** and **th**); when they are feeble and produced along with simultaneous laryngeal sounds (voice), we have **D** soft.

2. The **aspirates** embrace **S**, including **s** sharp, written **ss** or **sz**, which is produced without any audible laryngeal vibration; or soft, which requires the voice. Then, also, there are modifications according to the position where the noises are produced. The sharp aspirates include **Sch**, and the hard English **Th**; to the soft belong the French **J** soft, and the English **Th** soft. **L**, which occurs in many modifications, belongs here—*e.g.*, the **L** soft of the French. **L** may be sounded soft with the voice, or sharp without it.

3. The **vibratives**, or **R**, which is generally voiced, but it can be formed without the larynx.

The **resonants** are **N**-sounds, which also occurs in several modifications.

C. Consonants of the Third Articulation Position.

1. The **explosives** are the **K**-sounds, which are hard and breathed and not voiced; **G**-sounds, which are voiced.
2. The **aspirates**, when hard and breathed but not voiced, the **Ch**, and when sounded softly and not voiced, **J** is formed.
3. The **vibrative** is the palatal **R**, which is produced by vibration of the uvula (Brücke).
4. The **resonant** is the palatal **N**.

D. Consonants of the Fourth Articulation Position.

1. An **explosive** sound does not occur when the glottis is forced open, if a vowel is loudly sounded with the glottis previously closed. If this occurs during whispering, a feeble short noise, due to the sudden opening of the glottis, may be heard.
2. The **aspirates** of the glottis are the **H**-sounds, which are produced when the glottis is moderately wide.
3. A **glottis-vibrative** occurs in the so-called laryngeal **R** of Lower Saxon (Brücke).
4. A **laryngeal resonant** cannot exist.

The combination of different consonants is accomplished by the successive movements necessary for each being rapidly executed. Compound consonants, however, or such as are formed when the oral parts are adjusted simultaneously for two different consonants, so that a mixed sound is formed from the two. Examples: Sch—tsch, tz, ts—Ps (ψ)—Ks (X Ξ).

319. Pathological Variations of Voice and Speech.

Aphonia.—Paralysis of the motor nerves (vagus) of the larynx by injury, or the pressure of tumours, causes *aphonia* or *loss of voice* (Galen). In aneurism of the aortic arch, the left recurrent nerve may be paralysed from pressure. The laryngeal nerves may be temporarily paralysed by rheumatism, over exertion, and hysteria, or by serous effusions into the laryngeal muscles. If the tensors are paralysed, **monotonia** is the chief result: the disturbances of respiration in paralysis of the larynx are important. As long as the respiration is tranquil, there may be no disturbance, but as soon as increased respiration occurs, great dyspnœa sets in, owing to the inability of the glottis to dilate.

If only *one* vocal cord is paralysed, the voice becomes impure and falsetto-like, while we may feel from without that there is less vibration on the paralysed side (Gerhardt). Sometimes the vocal cords are only so far paralysed that they do not move during phonation, but do so during forced respiration and during coughing (*phonetic paralysis*).

Diphthongia.—Incomplete unilateral paralysis of the recurrent nerve is sometimes followed by a *double tone*, owing to the unequal tension of the two vocal cords. According to Türk and Schnitzler, however, the

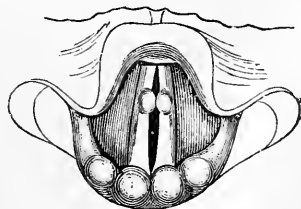

Fig. 276.

Tumours on the vocal cords causing double tone from the larynx.

double tone occurs when the two vocal cords touch at some part of their course (*e.g.*, from the presence of a tumour, Fig. 276), so that the glottis is divided into two unequal portions, each of which produces its own sound.

Hoarseness is caused by mucus upon the vocal cords, by roughness, swelling, or looseness of the cords. If, while speaking, the cords are approximated, and suddenly touch each other, the "speech is broken," owing to the formation of nodal points (§ 352). Disease of the pharynx, naso-pharyngeal cavity, and uvula may produce a change in the voice *reflexly*.

Paralysis of the soft palate (as well as congenital perforation or cleft palate), causes a *nasal timbre* of all vowels; the former renders difficult the normal formation of consonants of the third articulation position; resonance is imperfect, while the explosives are weak, owing to the escape of the air through the nose.

Paralysis of the tongue weakens I; E and A (Æ) are less easily pronounced, while the formation of consonants of the second and third articulation position is affected. The term *aphthongia* is applied to a condition, in which every attempt to speak is followed by spasmodic movements of the tongue (Fleury).

In **paralysis of the lips** (*facial nerve*), and in hare lip, regard must be had to the formation of consonants of the first articulation position. When the nose is closed, the speech has a characteristic sound. The normal formation of resonants is of course at an end. After excision of the larynx, a metal reed, enclosed in a tube, and acting like an artificial larynx, is introduced between the trachea and the cavity of the mouth (Czerny).

Stammering is a disturbance of the formation of sounds. [Stammering is due to long-continued spasmodic contraction of the diaphragm, just as hiccough is (p. 249), and, therefore, it is essentially a spasmodic inspiration. As speech depends upon the expiratory blast, the spasm prevents expiration. It may be brought about by mental excitement or emotional conditions. Hence, the treatment of stammering is to regulate the respirations. In **stuttering**, which is defective speech due to inability to form the proper sounds, the breathing is normal.]

320. Comparative—Historical.

Speech may be classified with the expression of the emotions (Darwin). Psychological excitement causes in man characteristic movements, in which certain groups of muscles are always concerned (*e.g.*, laughing, weeping, the facial expression in anger, pain, shame, &c.). Primarily, the movements of expression are *reflex* motor phenomena; when they are produced for purposes of explanation, they are voluntary imitations of this reflex. Besides the emotional movements, impressions upon the sense-organs produce characteristic reflex movements, which may be used for purposes of expression (Geiger)—*e.g.*, stroking or painful stimulation of the skin, movements after smelling pleasant or unpleasant or disagreeable odours, the action of sound and light, and the perception of all kinds of objects.

The expression of the emotions occurs in its simplest form in what is known as conversation or expression by means of *signs* or pantomime. Another means is the *imitation of sounds* by the organ of speech, constituting *onomatopoesy*, *e.g.*, the hissing of a stream, the roll of thunder, the tumult of a storm, whistling, &c. The expression of speech is, of course, dependent upon the process of ideation and perception.

The *occurrence of different sounds* in different languages is very interesting. Some languages (*e.g.*, of the Hurons) have no labials; in some South Sea Islands, no laryngeal sounds are spoken; *f* is absent in Sanscrit and Finnish; the short *e*, *o*, and the soft sibilants in Sanscrit; *d*, in Chinese and Mexican, *s*, in many Polynesian languages; *r*, in Chinese, &c.

Voice in Animals.—Animals, more especially the higher forms, can express their emotions by facial and other gestures. The vocal organs of **mammals** are essentially the same as those of man. Special *resonance organs* occur in the orang-outang, mandril, macacus, and mycetes monkeys in the form of large cheek pouches, which can be inflated with air, and open between the larynx and the hyoid bone.

Birds have an upper (larynx) and a lower larynx (*syriux*), the latter being placed at the bifurcation of the trachea, and is the true vocal organ. Two folds of mucous membrane (three in singing birds) project into each bronchus, and are rendered tense by muscles, and are thus adapted to serve for the production of voice.

Amongst **reptiles**, the tortoises produce merely a sniffing sound, which in the Emys, has a peculiar piping character. The blind snakes are voiceless, the chameleon and the lizards have a very feeble voice; the cayman and crocodile emit a feeble roaring sound, which is lost in some adults owing to changes in the larynx. The *snakes* have no special vocal organs, but by forcing out air from their capacious lung, they make a peculiar hissing sound which in some species is loud. Amongst **amphibians**, the frog has a larynx provided with muscles. The sound emitted without any muscular action is a deep intermittent tone, while more forcible expiration, with contraction of the laryngeal constrictors, causes a clearer continuous sound. The male, in *Rana esculenta*, has at each side of the angle of the mouth a sound-bag, which can be inflated with air and acts as a resonance chamber. The "croaking" of the male frog is quite characteristic. In *Pipa*, the larynx is provided with two cartilaginous rods, which are thrown into vibration by the blast of air, and act like vibrating rods or the limbs of a tuning-fork. Some **fishes** emit sounds, either by rubbing together the upper and lower pharyngeal bones, or by the expulsion of air from the swimming bladder, mouth, or anus.

Some **insects** cause sounds partly by forcing the expired air through their stigmata provided with muscular reeds, which are thus thrown into vibration (bees and many diptera). The wings, owing to the rapid contraction of their muscles, may also cause sounds (flies, cockroach, bees). The *Sphinx atropos* (death-head moth) forces air from its sucking stomach. In others, sounds are produced by rubbing their legs on the wing-cases (*Acridium*), or the wing-cases on each other (*Gryllus*, locust), or on the thorax (*Cerambyx*), on the leg (*Geotrupes*), on the abdomen or the margin of the wing (*Nekrophorus*). In *Cicadaciæ*, membranes are pulled upon by muscles, and are thus caused to vibrate. Friction sounds are produced between the cephalothorax and the abdomen in some spiders (*Theridium*), and in some crabs (*Palinurus*). Some mollusca (*Pecten*) emit a sound on separating their shells.

Historical.—The Hippocratic School was aware of the fact that division of the trachea abolished the voice, and that the epiglottis prevented the entrance of food into the larynx. Aristotle made numerous observations on the voice of animals. The true cause of the voice escaped him as well as Galen. Galen observed complete loss of voice after double pneumothorax, after section of the intercostal muscles or their nerves, as well as after destruction of part of the spinal cord, even although the diaphragm still contracted. He gave the cartilages of the larynx the names that still distinguish them; he knew some of the laryngeal muscles, and asserted that voice was produced only when the glottis was narrowed. He compared the larynx to a flute. The weakening of the voice, in feeble conditions, especially after loss of blood, was known to the ancients. Dodart (1700) was the first to explain voice as due to the vibration of the vocal cords by the air passing between them.

The production of vocal sounds attracted much attention amongst the ancient Asiatics and Arabians—less amongst the Greeks. Pietro Ponce (†1584) was the

first to advocate instruction in the art of speaking in cases of dumbness. Bacon (1638) studied the shape of the mouth for the pronunciation of the various sounds. Kratzenstein (1781) made an artificial apparatus for the production of vowel sounds, by placing resonators of various forms over vibrating reeds. Von Kempelen (1769-1791) constructed the first speaking-machine. Rob. Willis (1828) found that an elastic, vibrating spring gives the vowels in the series—U, O, A, E, I—according to the depth or height of its tone; further, that by lengthening or shortening an artificial resonator on an artificial vocal apparatus, the vowels may be obtained in the same series. The newest and most important investigations on speech are by Wheatstone, v. Helmholtz, Donders, Brücke, &c., and are mentioned in the context. Hensen succeeded in showing exactly the pitch of vocal tone, thus:—The tone is sung against a König's capsule with a gas flame. Opposite the flame is placed a tuning-fork vibrating horizontally, and in front of one of its limbs is a mirror, in which the image of the flame is reflected. When the vocal tone is of the same number of vibrations as the tuning-fork, the flame in the mirror shows one elevation, if double—*i.e.*, the octave, 2, and with the double octave, 4 elevations.

General Physiology of the Nerves and Electro-Physiology.

321. Structure and Arrangement of the Nerve Elements.

THE nervous elements present two distinct forms :—

1. *Nerve-Fibres*, { Non-medullated.
Medullated.
2. *Nerve-Cells*, { Various forms and
functions.

An aggregation of nerve-cells constitutes a nerve-ganglion. The *fibres* represent a *conducting* apparatus, and serve to place the central nervous organs in connection with peripheral end-organs. The *nerve-cells*, however, besides transmitting impulses, act as *physiological centres* for automatic or reflex movements for the sensory, perceptive, trophic, and secretory functions.

I. *Nerve-Fibres* occur in several forms :—

1. **Primitive Fibrils.**—The simplest form of nerve-fibril, which is visible with a magnifying power of 500–800 diameters linear, consists of *primitive nerve-fibrils* (Max Schultze) or *axial fibrils* (Waldeyer). They are very delicate fibres (Fig. 277, 1), often with small varicose swellings here and there in their course, which, however, are due to changes *post mortem*. They are stained of a brown or purplish colour by the gold chloride method, and they occur when a nerve-fibre is near its termination, being formed by the splitting up of the axis cylinder of the nerve-fibre, *e.g.*, in the terminations of the corneal nerves, the optic nerve-layer in the retina, the terminations of the olfactory fibres, and in a plexiform arrangement in non-striped muscle (p. 623). Similar fine fibrils occur in the grey matter of the brain and spinal cord, and the finely-divided processes of nerve-cells.

2. **Naked or simple axial cylinders** (Fig. 277, 2), which represent bundles of primitive fibrils held together by a slightly granular cement, so that they exhibit very delicate longitudinal striation with fine

granules scattered in their course. The best example is the axial cylinder process of nerve-cells (Fig. 277, I, *z*). [The thickness of the

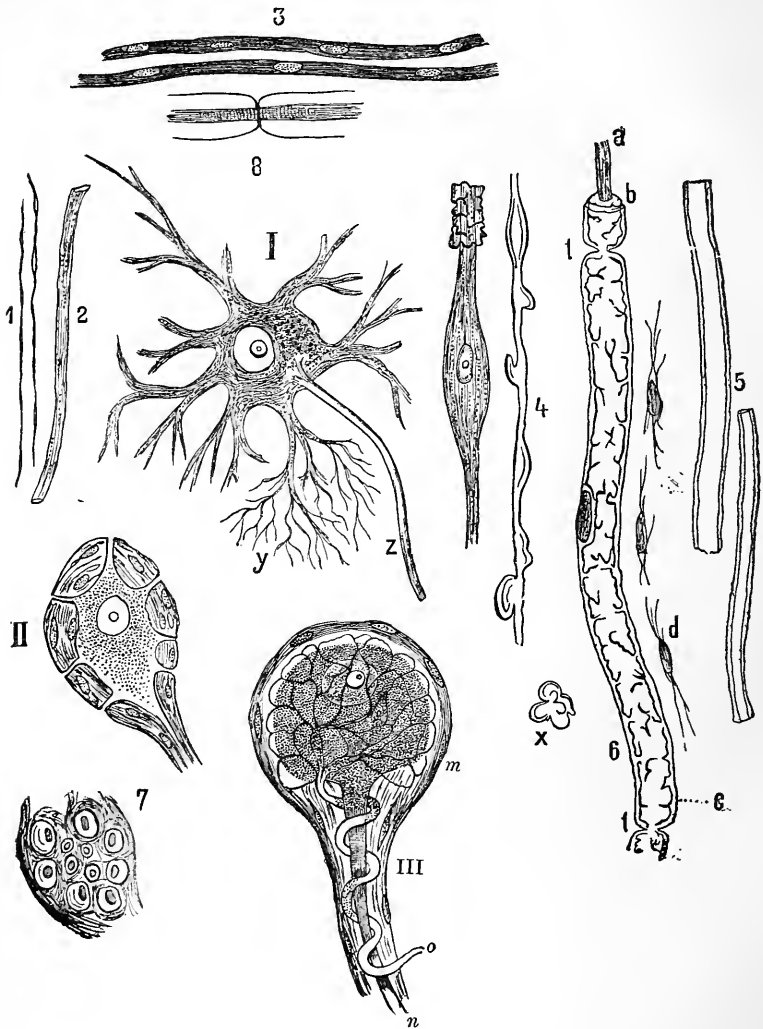

Fig. 277.

1, Primitive fibrillæ; 2, axis cylinder; 3, Remak's fibres; 4, medullated varicose fibre; 5, 6, medullated fibre, with Schwann's sheath; *c*, neurilemma; *t*, *t*, Ranvier's nodes; *b*, white substance of Schwann; *d*, cells of the endoneurium; *a*, axis cylinder; *x*, myelin drops; 7, transverse section of nerve-fibres; 8, nerve-fibre acted on with silver nitrate; I, multipolar nerve-cell from the spinal cord; *z*, axial cylinder process; *y*, protoplasmic processes; to the right of it a bipolar cell; II, peripheral ganglionic cell, with a connective-tissue capsule; III, ganglionic cell, with a spiral process; *m*, sheath; *o*, spiral, and *n*, straight process.

axis cylinder depends upon the number of fibrils entering into its composition.]

3. **Axis cylinders surrounded with Schwann's sheath, or Remak's fibres** (3·8–6·8 μ broad), the latter name being given to them from their discoverer (Fig. 277, 3). [These fibres are also called *pale* or *non-medullated*, and from their abundance in the sympathetic nervous system, sympathetic.] They consist of a sheath, corresponding to Schwann's sheath [neurilemma, or primitive sheath, which encloses an axial cylinder, while lying here and there under the sheath, and between it and the axial cylinder are nerve-corpuscles. These fibres are always fibrillated longitudinally.] The sheath is delicate, structureless, and elastic. Dilute acids clear up the fibres without causing them to swell up, while gold chloride makes them brownish-red. They are widely distributed in the sympathetic nerves [*e.g.*, splenic] and in the branches of the olfactory nerves. All nerves in the *embryo*, as well as the nerves of many invertebrata, are of this kind. [According to Ranvier, these fibres do not possess a sheath, but the nuclei are merely applied to the surface, or slightly embedded in the superficial parts of the fibre. These fibres also *branch* and form an anastomosing net-work. This the medullated fibres never do. These fibres, when acted on by silver nitrate, never show any crosses. The branched form occurs in the ordinary nerves of distribution, and they are numerous in the vagus, but the olfactory nerves have a distinct sheath, which is nucleated.]

4. **Axis cylinders, or nerve-fibrils, covered only by a medullary sheath, or white substance of Schwann**, are met with in the white and grey matter of the central nervous system, in the optic and auditory nerves. These *medullated nerve-fibres, without any neurilemma*, often show after death varicose swellings in their course, [due to the accumulation of fluid between the medulla or myelin and the axis cylinder]. Hence they are called *varicose fibres*. [The varicose appearance is easily produced by squeezing a small piece of the white matter of the spinal cord between a slide and a cover-glass. Nitrate of silver does not reveal any crosses, and there are no nodes of Ranvier, while osmic acid reveals no incisures. When acted upon by coagulating reagents, *e.g.*, chromic acid, the medullary sheath appears laminated, so that on transverse section, when the axis cylinder is stained, it is surrounded by concentric circles.]

5. **Medullated Nerve-Fibres, with Schwann's Sheath** (Fig. 277, 5, 6).—These are the most complex nerve-fibres, and are 10–22·6 μ [$\frac{1}{12000}$ to $\frac{1}{3500}$ inch] broad. They are most numerous in, and in fact they make up the great mass of, the cerebro-spinal nerves, although they are also present in the sympathetic nerves. [When examined in the fresh

and living condition *in situ*, they appear refractive and homogeneous (Ranvier, Stirling); but, if acted upon by reagents, they are not only refractive, but exhibit a *double* contour, the margins being dark and well defined.] Each fibre consists of—

- [1. Schwann's sheath, neurilemma, or primitive sheath;
2. White substance of Schwann, medullary sheath, or myelin;
3. Axis cylinder composed of fibrils;
4. Nerve-corpuscles.]

A. The axis cylinder, which occupies $\frac{1}{4}$ to $\frac{1}{5}$ of the breadth of the fibre is the essential part of the nerve, and lies in the centre of the fibre (Fig. 277, 6, *a*) like the wick in the centre of a candle. Its usual shape is cylindrical, but sometimes it is flattened or placed eccentrically, [most probably due to the hardening process employed]. It is composed of *fibrils* [united by cement; they become more obvious near the terminations of the nerve, or after the action of reagents, which sometimes cause the fibrils to appear beaded. It is quite transparent, and stains deeply with carmine or logwood], while during life, its *consistence* is semi-fluid. According to Kupffer, a fluid—nerve-serum—lies between the fibrils, [while, according to other observers, the whole cylinder is enclosed in an elastic sheath peculiar to itself and composed of neuro-keratin].

Fromann's Lines.—Chloroform and collodion render it visible, while it is most easily isolated as a solid rod, by the action of nitric acid with excess of potassium chlorate. When acted on by silver nitrate, Fromann observed transverse markings on it, but their significance is unknown (Fig. 277, 8).

B. White substance of Schwann, medullary sheath or myelin surrounds the axis cylinder, like an insulating medium around an electric wire. In the perfectly fresh condition, it is quite homogeneous, highly glistening, bright and refractive; its consistence is fluid, so that it oozes out of the cut ends of the fibres in spherical drops (Fig. 277, *x*) [*myelin drops*, which are always marked by concentric lines, are highly refractive, and best seen when a fresh nerve is teased in salt solution]. After death or after the action of reagents, it shrinks slightly from the sheath, so that the fibres have a *double contour*, while the substance itself breaks up into smaller or larger droplets, due not to coagulation (Pertik) but, according to Toldt, to a process like emulsification, the drops pressing against each other. Thus the fibre is broken up into masses so that it has a characteristic appearance (Fig. 277, 6). It contains a large amount of *cerebrin*, which swells up to form myelin-like forms in warm water. It also contains fatty matter, so that these fibres are blackened by osmic acid, [while boiling ether extracts cholesterin from them]. Chloroform,

ether, and benzin, by dissolving the fatty and some other constituents of the fibres, make them very transparent. [Some observers describe a fluid lying between the medulla and the axis cylinder.]

C. The sheath of Schwann, or the neurilemma, lies immediately outside of and invests the white sheath (Fig. 277, 6, *c*), and is a delicate, structureless membrane, comparable to the sarcolemma of a muscular fibre.

D. Nerve-Corpuscles.—At fairly wide intervals under the neurilemma, and lying in depressions between it and the medullary sheath, are the nucleated *nerve-corpuscles* which are readily stained by pigments. [They may be compared to the muscle-corpuscles, the nuclei being surrounded by a small amount of protoplasm which sometimes contains pigment. They are not so numerous as in muscle.]

Ranvier's Nodes or Constrictions.—The neurilemma forms, in broad fibres at longer, and in narrower ones at shorter, intervals, the *nodes* or *constrictions of Ranvier* (Fig. 276, 6, *t, t*, Fig. 278, *fs*). They are con-

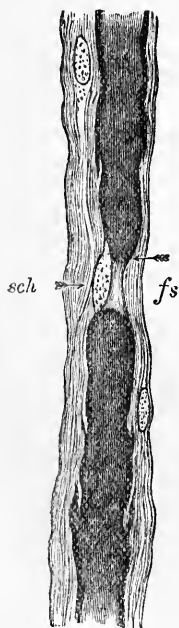

Fig. 278.

Medullated nerve-fibres blackened by osmic acid—*fs*, Ranvier's node; *sch*, Schwann's sheath (after Eichhorst).

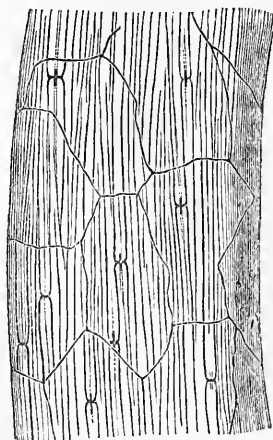

Fig. 279.

Intercostal nerve of a mouse consisting of a single fasciculus of nerve-fibres, stained with silver nitrate. Endothelial sheath stained, and some nodes of Ranvier indicated by crosses \times 200 (Knott, after Ranvier).

strictions which occur at regular intervals along a nerve-fibre; at them the white substance of Schwann is interrupted, so that the sheath of Schwann lies upon the axis cylinder [or its elastic sheath] at the nodes. The part of the nerve lying between any two nodes [is called an *inter-annular* or *inter-nodal segment*], and each such segment contains one or more nuclei, so that some observers look upon the whole segment as equivalent to one cell.

The function of the nodes seems to be to permit the diffusion of plasma through the outer sheath into the axis cylinder, while the decomposition products are similarly given off. [A colouring matter like micro-carmin diffuses into the fibre only at the nodes, and stains the axis cylinder red, although it does not diffuse through the white substance of Schwann.]

[*Incisures* (of Schmidt and Lantermann).—Each interannular segment in a stretched nerve, shows a number of oblique lines running across the white substance, which are called *incisures*. They indicate that the segment is built up of a series of conical sections, each of which is bevelled at its ends, and the bevels are arranged in an imbricate manner, the one over the other (Fig. 278), while the slight interval between them appears as an incisure. Each such section of the white matter is called a *cylinder cone* (Kuhnt)].

Neuro-Keratin Sheath.—According to Ewald and Kühne, the axis cylinder, as well as the white substance of Schwann, is covered with an excessively delicate sheath, consisting of *neuro-keratin*, and the two sheaths are connected by numerous transverse and oblique fibrils, which permeate the white substance. [The myelin seems to lie in the interstices of this mesh-work.]

[**Rod-like Structures in Myelin.**—If a nerve be hardened in *ammonium chromate* (or *picric acid*), M'Carthy has shown that the myelin exhibits rod-like structures, radiating from the axis cylinder outwards, and which are stained with logwood and carmine. The rods are probably not distinct from each other, but are perhaps part of the neuro-keratin net-work already described.]

Action of Nitrate of Silver.—When a small nerve, *e.g.*, the intercostal nerve of a mouse, is acted on by silver nitrate, it is seen to be covered by an endothelial sheath composed of flattened endothelial cells (Fig. 279), while the nerve-fibres themselves exhibit *crosses* along their course. These crosses are due to the penetration of the silver solution at the nodes, where it stains the cement-substance and also part of the axis cylinder, so that the latter sometimes exhibits transverse markings called *Fromann's lines* (Fig. 277, 8)].

In the spinal nerves, those fibres are thickest which have the longest course before they reach their end-organ (Schwalbe), while those ganglion cells are largest which send out the longest nerve-fibres (Pierret).

Division of Nerves.—Nerve-fibres run in the nerve-trunks without dividing; but, when they approach their termination, they often divide

dichotomously [at a node], giving rise to two similar fibres, but there may be several branches at a node (Fig. 281, *t*).

[The divisions are numerous in motor nerves to striped muscles.] In the electrical nerves of the malapterurus and gymnotus, there is a great accumulation of Schwann's sheaths round a nerve, so that a nerve-fibre is as thick as a sewing needle. Such a fibre when it divides, breaks up into a bundle of smaller fibres.

Nerve Sheaths.—[An anatomical nerve-trunk consists of *bundles* of nerve-fibres. The bundles are held together by a common connective-tissue sheath (Fig. 280, *ep*), the *epineurium* (Axel Key and Retzius) which contains the larger blood-vessels, lymphatics, and sometimes fat and plasma cells.] Each bundle is surrounded with its own sheath or *perineurium* (*pe*), [which consists of lamellated connective-tissue disposed circularly, and between the lamellæ are lymph spaces lined by flattened endothelial plates.] These lymph spaces may be injected from and communicate with the lymphatics.

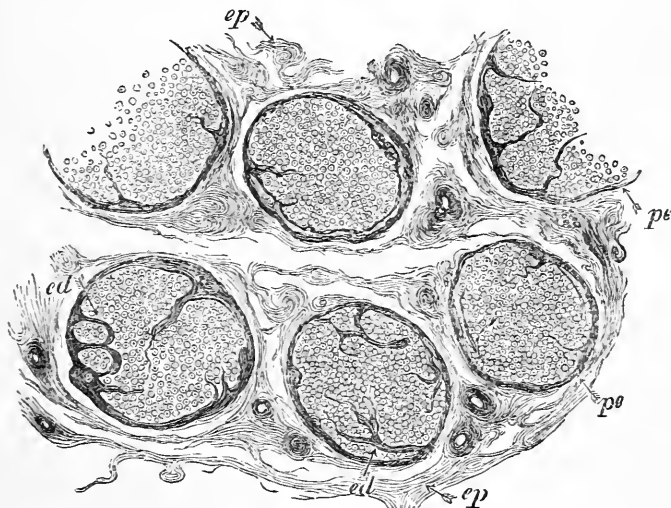

Fig. 280.

Transverse section of part of the median nerve—*ep*, epineurium; *pe*, perineurium; *ed*, endoneurium (after Eichhorst).

[The nerve-fibres within any bundle are held together by delicate connective-tissue, which penetrates between the adjoining fibres, constituting the *endoneurium* (*ed*). It consists of delicate fibres with branched connective-tissue corpuscles (Fig. 277, 6, *d*), and in it lie the capillaries, which are not very numerous, and are arranged to form elongated open meshes.]

[**Henle's Sheath.**—When a nerve is traced to its distribution, it branches and becomes smaller, until it may consist only of a few

bundles or even a single bundle of nerve-fibres. As the bundle branches, it has to give off part of its lamellated sheath or perineurium to each branch, so that as we pass to the periphery, the smaller bundles are surrounded by few lamellæ. In a bundle containing only a few fibres, this sheath may be much reduced, or consist only of thin flattened connective-tissue corpuscles with a few fibres. A sheath surrounding a few nerve-fibres is called *Henle's Sheath* (Ranvier).

[**Nervi Nervorum.**—Marshall and V. Horsley have shown, that the nerve sheaths are provided with special nerve-fibres, in virtue of which they are endowed with sensibility.]

Development.—At first nerve-fibres consist only of fibrils, which become covered with connective substance, and ultimately the white substance of Schwann is developed in some of them. The growth in length of the fibres takes place by elongation of the individual “interannular” segments, and also by the new formation of these (Vignal).

II. Ganglionic or nerve-cells are partly regarded as cells and partly as complex structures. We distinguish—

1. **Multipolar nerve-cells** (Fig. 277, I—Purkinje, 1838) occur partly as *large* cells (100 μ , and are, therefore, visible to the unaided eye), in the anterior horn of the spinal cord, and in a different form in the cerebellum, and partly in a *smaller* form (20–10 μ) in the posterior horns of the spinal cord, many parts of the cerebrum and cerebellum, and in the retina. They may be spherical, ovoid, pyramidal [cerebrum], pear- or flask-shaped [cerebellum], and are provided with numerous branched processes, which give the cells a characteristic appearance. They are devoid of a cell envelope, are of soft consistence, and exhibit a fibrillated structure, which may extend even into the processes. Fine granules lie scattered throughout the cell-substance between the fibrils. Not unfrequently yellow or brown granules of pigment are also found, either collected at certain parts in the cell or scattered throughout it. The relatively large *nucleus* consists of a clear envelope enclosing a resistant substance. It does not appear to have a membrane in youth (Schwalbe). Within the nucleus lies the *nucleolus*, which in the recent condition is angular, provided with processes and capable of motion, but after death, is highly refractive and spherical. One of the *processes* is always *unbranched*, constituting the *axial cylinder process* (I, z) which remains unbranched, but it soon becomes covered with the white substance of Schwann, and the other sheaths of a medullated nerve, so that it becomes the axial cylinder of a nerve-fibre. [Thus a nerve-fibre is merely an excessively long, unbranched process of a nerve-cell pushed outwards towards the periphery.] It is not definitely ascertained that the cerebral cells have such processes. All the other processes divide very frequently, until they form a branched, root-like, complex arrangement of the finest primitive fibrils. These are called protoplasmic

processes (I, *y*). By means of these processes adjoining cells are brought into communication with each other, so that impulses can be conducted from one cell to another. Further, many of these fibrils approximate to each other, and join together to form axis cylinders of other nerve-fibres.

2. Bipolar cells are best developed in fishes—*e.g.*, in the spinal ganglia of the skate, and in the Gasserian ganglion of the pike. They appear to be nucleated, fusiform enlargements of the axis cylinder (Fig. 277, on the right of I). The white substance often stops short on each side of the enlargement, but sometimes the white substance and the sheath of Schwann pass over the enlargement.

3. Nerve-cells with connective-tissue capsules occur in the peripheral ganglia of man (Fig. 277, II), *e.g.*, in the spinal ganglia. The soft body of the cell, which is provided with several processes, is covered by a thick, tough capsule composed of several layers of connective-tissue corpuscles; while the inner surface of the composite capsule is lined by a layer of delicate endothelial cells (Fig. 281). The body of the cells in the spinal ganglia, is traversed by a net-work of fine fibrils (Flemming). The capsule is continuous with the sheath of the nerve-fibre.



Fig. 281.

Cell from the Gasserian ganglion—*n*, nuclei of the sheath; *t*, fibre dividing at a node of Ranvier (Schwalbe).

Rawitz and G. Retzius find, that the cells of the spinal ganglia are *unipolar*, the out-going fibre taking a half-turn within the capsule before it leaves the cell (Fig. 281). Retzius [and Ranvier] observed the process to divide like a T. Perhaps this division corresponds to the two processes of a bipolar cell.

The jugular ganglion and plexus gangliiformis vagi in man, contain only unipolar cells, so that, in this respect, they may be compared to spinal ganglia. The same is the case in the Gasserian ganglion; while the ciliary, sphenopalatine, otic, and submaxillary ganglia structurally resemble the ganglia of the sympathetic.

4. Ganglionic cells with spiral fibres (Beale, J. Arnold) occur chiefly in the abdominal sympathetic of the frog. The body of the cell is

usually pyriform in shape, and from it there proceeds a straight, unbranched process (Fig. 277, III, *n*), which ultimately becomes the axis cylinder of a nerve. A spiral fibre springs from the cell (? a network), emerges from it, and curves in a spiral direction round the former (*o*). The whole cell is surrounded by a nucleated capsule (*m*). We know nothing of the significance of the different fibres.

322. Chemistry of the Nervous Substance.

Mechanical Properties of Nerves.

1. **Proteids.**—Albumin occurs chiefly in the axis cylinder and in the substance of the ganglionic cells. Some of this proteid substance presents characters not unlike those of myosin (p. 625). Dilute solution of common salt extracts a proteid from nervous matter, which is precipitated by the addition of much water, and also by a concentrated solution of common salt (Petrowsky). *Potash-albumin* and a *globulin-like substance* are also present. *Nuclein* occurs especially in the grey matter (p. 504), while *neuro-keratin*, a body containing much sulphur and closely related to keratin, occurs in the corneous sheath of nerve-fibres (p. 714). If grey nervous matter be subjected to artificial digestion with trypsin (p. 341), both of these substances remain undigested (Kühne and Ewald). Pure neuro-keratin is obtained by treating the residue with caustic potash. The *sheath of Schwann* does not yield gelatin, but a substance closely related to *elastin* (p. 505), from which it differs, however, in being more soluble in alkalis. The connective-tissue of nerves yields gelatin.

2. **Fats and other allied substances soluble in ether**, more especially in the white matter :—

(a.) **Cerebrin**, free from phosphorus (p. 508).

It is a white powder composed of spherical granules soluble in hot alcohol and ether, but insoluble in cold water. It is decomposed at 80°C., and its solutions are neutral. When boiled for a long time with acids, it splits up into a left-rotatory body like sugar, and another unknown product. *Preparation.*—Rub up the brain into a thin fluid with baryta water. Extract the separated coagulum with boiling alcohol. The extract is frequently treated with cold ether to remove the cholesterol (p. 510) (W. Müller). Parkus separated from cerebrin its homologue, *homocerebrin*, which is slightly more soluble in alcohol, and the clyster-like body, *encephalin*, which is soluble in hot water.

(b.) **Lecithin** (pp. 46, 509) and its decomposition products—glycerin-phosphoric acid and oleo-phosphoric acid.

Neurin (or Cholin = $C_7H_{15}NO_2$) is a strongly alkaline, colourless fluid, forming crystalline salts with acids. It is soluble in water and alcohol, and has been formed synthetically from glycol and trimethylamin. Lecithin is a salt of the base neurin.

(c.) **Protagon**, which contains N and P, is similar to cerebrin, and is, according to its discoverer (Liebreich), the chief constituent of the brain. According to Hoppe-Seyler [and Diaconow], it is a mixture of lecithin and cerebrin. [The investigations of Gamgee and Blankenhorn have shown, however, that protagon is a definite chemical body. They find that, instead of being unstable, it is a very stable body.]

3. The following substances are extracted by water :—Xanthin and hypoxanthin (Scherer, p. 514), kreatin (Lerch, p. 513), inosit (W. Müller, p. 562), ordinary lactic acid (Gscheidlen), and volatile fatty acids; leucin (in disease), urea (in uræmia). All these substances are for the most part products of the regressive metabolism of the tissues.

Reaction.—Nervous substance when passive, is neutral or feebly alkaline in reaction, while active (? and dead) it is acid (Funke). The grey matter of the brain is always acid (Gscheidlen), and after death, it becomes more acid. The nerves, after death, have a more solid consistence, so that in all probability some coagulation or change, comparable to the stiffening of muscle (§ 295), occurs in them after death, while, at the same time, a free acid is liberated. If a fresh brain be rapidly “broiled” at 100°C., it, like a muscle similarly treated, remains alkaline (p. 632).

Chemical Composition.

	Grey Matter.	White Matter.
	81·6 per cent.	68·4 per cent.
The <i>solids</i> consist of—	18·4 ”	31·6 ”
Albumins and Glutin,	55·4 ”	24·7 ”
Lecithin,	17·2 ”	9·9 ”
Cholesterin and Fats,	18·7 ”	52·1 ”
Cerebrin,	0·5 ”	9·5 ”
Substances insoluble in Ether, . .	6·7 ”	3·3 ”
Salts,	1·5 ”	0·5 ”
	100·0	100·0

In 100 parts of Ash, Breed found the following :—

Potash, 32·42	Phosphate of Iron, 1·23
Soda, 10·69	Phosphoric Acid in combination, 39·02
Magnesia, 1·23	” ” free, 8·78
Lime, 0·72	Sulphuric Acid, 0·75
Sodic Chloride, 5·74	Silica, 0·42

Mechanical Properties of Nerves.—One of the most remarkable mechanical properties of nerve-fibres is the absence of elastic tension according to the varying positions of the body. Divided nerves do not

retract, such nerves exhibit delicate, microscopic, transverse folds (Fontana's transverse markings), [like watered silk].

The cohesion of a nerve is very considerable. When a limb is forcibly torn from the body, as sometimes happens from its becoming entangled in machinery, the nerve not unfrequently remains unsevered, while the other soft parts are ruptured. [Tillaux found that a weight of 110-120 lbs. was required to rupture the sciatic nerve at the popliteal space, while to break the median or ulnar nerve of a fresh body, a force equal to 40-50 lbs. was required. The toughness and elasticity of nerves are often well shown in cases of injury or gun-shot wounds. The median or ulnar nerve will gain 15-20 centimetres (6-8 inches) before breaking. Weir Mitchell has shown that a healthy nerve will bear a very considerable amount of pressure and handling, and in fact the method of nerve-stretching depends upon this property of a nerve-trunk.]

323. Metabolism of Nerves.

Influence of Blood Supply.—We know very little regarding the metabolic processes that occur in nerve-tissue. Some *extractives* are obtained from nerve-tissue, and they may, perhaps, be regarded as decomposition products (p. 719). It has not been proved satisfactorily that during the activity of nerves, there is an exchange of O and CO₂. That there is an exchange of materials within the nerves is proved by the fact that, after *compression of the blood-vessels* of the nerves, the excitability of the nerves falls, and is restored again when the circulation is re-established. Compression of the abdominal aorta causes paralysis and numbness of the lower half of the body, while occlusion of the cerebral vessels causes almost instantaneously, cessation of the cerebral functions. The metabolism of the central nervous organs is much more active than that of the nerves themselves. [If the abdominal aorta of a rabbit be compressed for a few minutes, the hind limbs are quickly paralysed, the animal crawls forward on its fore-legs, drawing the hind limbs in an extended position after it.]

324. Excitability of the Nerves—Stimuli.

Nerves possess the property of being thrown into a state of excitement by *stimuli*, and are, therefore, said to be *excitable* or irritable. The stimuli may be applied to, and may act upon, any part of the nerve. [The following are the various kinds of *stimuli*—*i.e.*, modes of motion, which act upon nerves]:—

1. **Mechanical stimuli** act upon nerves, when they are applied with sufficient rapidity to produce a change in the form of the nerve particles—*e.g.*, a blow, pressure, pinching, tension, puncture, section. In the case of sensory nerves, when they are stimulated, pain is produced, as is felt when a limb “sleeps,” or when pressure is exerted upon the ulnar nerve at the bend of the elbow. When a *motor* nerve is stimulated, motion results in the muscle attached to the nerve. If the continuity of the nerve-fibres be destroyed, or, what is the same thing, if the continuity of the axial cylinder be interrupted by the mechanical stimulus, the *conduction* of the impulse across the injured part is interrupted. If the molecular arrangements of the nerve be permanently deranged—*e.g.*, by a violent shock, the excitability of the nerves may be thereby extinguished.

A slight blow, applied to the radial nerve in the fore-arm, or to the axillary nerves in the supraclavicular groove, is followed by a contraction of the muscles supplied by these nerves. Under pathological conditions, the excitability of a nerve for mechanical stimuli may be increased enormously.

Tigerstedt ascertained that the *minimal* mechanical stimulus is represented by 900 milligram-millimetres, and the *maximum* by 7,000–8,000. Strong stimuli cause fatigue, but the fatigue does not extend beyond the part stimulated. A nerve when stimulated mechanically does not become acid. Slight pressure without tension increases the excitability, which diminishes after a short time. *Continued* pressure upon a *mixed* nerve paralyses the motor sooner than the sensory fibres. If the stimulus be applied *very gradually*, the nerve may be rendered inexcitable, without manifesting any signs of its being stimulated (Fontana, 1785). Paralysis, due to continuous pressure gradually applied, may occur in the region supplied by the brachial nerves; the left recurrent laryngeal nerve also may be similarly paralysed from the pressure of an aneurism of the arch of the aorta.

Nerve-stretching is one of the methods that has recently been employed for therapeutical purposes. If a nerve be exposed and stretched, or if a certain tension be exerted upon it, this acts as a stimulus. Slight extension increases the reflex excitability (Schleich), while violent extension produces a temporary diminution or abolition of the excitability (Valentin). The centripetal fibres (sensory) of the sciatic nerve are sooner paralysed thereby than the centrifugal (motor)—(Conrad). During the process of extension, mechanical changes are produced, either in the nerve itself or in its end-organs, causing an alteration of the excitability, but it may also affect the central organs. The paralysis which sometimes occurs after forcible stretching, usually rapidly disappears. Therefore, when a nerve is in an excessively excitable condition, or when this is due to an inflammatory fixation or constriction of the nerve at some part of its course, then nerve-stretching may be useful, partly by diminishing the excitability, partly by breaking up the inflammatory adhesions. In cases where stimulation of an afferent nerve gives rise to *epileptic or tetanic spasms*, nerve-stretching may be useful by dimin-

ishing the excitability at the periphery, in addition to the other effects already described. It has also been employed in some spinal affections, which may not as yet have resulted in marked degenerative changes.

Tetanomotor.—For physiological purposes, a nerve may be stimulated mechanically by means of Heidenhain's *tetanomotor*, which is simply an ivory hammer attached to the prolonged spring of a Neef's hammer of an induction machine. The rapid vibration of the hammer communicates a series of mechanical shocks to the nerve upon which it is caused to beat. Rhythmic extension of a nerve causes contractions and even tetanus.

2. **Thermal Stimuli.**—If a frog's nerve be heated to 45°C., its *excitability* is first increased and then diminished. The higher the temperature, the greater is the excitability, and the shorter its duration (Afanasiëff). Sudden cooling of a nerve to 5°C. acts as a stimulus, causing contraction in a muscle, while sudden heating to 40°–45°C., produces the same result. If the temperature be increased still more, instead of a single contraction, a tetanic condition is produced. All such rapid variations of temperature quickly exhaust the nerve and kill it. If a nerve be heated to 50°C. for a short time, its excitability and conductivity are abolished. The frog's nerve alone regains its excitability on being cooled (Pickford, J. Rosenthal). If the temperature be raised to 65°C., the excitability is abolished without the occurrence of a contraction, while its medulla is broken up (Eckhard). If a nerve be frozen gradually, it retains its excitability on being thawed. The excitability lasts long in a *cooled* nerve; in fact, it is increased in a motor nerve, but the contractions are not so high and more extended, while the conduction in the nerve takes place more slowly. Amongst *mammalian* nerves, the afferent and vaso-dilator nerves at 45°–50°C., exhibit the results of stimulation, while the others only show a change in their excitability. When cooled to + 5°C., the excitability of all the fibres is diminished (Grützner).

3. **Chemical stimuli** excite nerves when they act so as to change their constitution with a certain rapidity (p. 637). Most chemical stimuli act by first increasing the nervous excitability, and then diminishing or paralyzing it. Chemical stimuli, as a rule, have less effect upon *sensory* than upon motor fibres (Eckhard, Setschenow). According to Grützner, the inactivity of chemical stimuli, so often observed when they are applied to sensory nerves, depends in great part upon the non-simultaneous stimulation of all the nerve-fibres. Amongst chemical stimuli are—(a) Rapid *abstraction of water* by dry air, blotting paper, exposure in a chamber containing sulphuric acid, or by the action of solutions which absorb fluids—*e.g.*, concentrated solutions of neutral alkaline salts, sugar, urea, concentrated glycerin (and ? some

metallic salts). The subsequent addition of water may abolish the contractions, while the nerve may still remain excitable. The abstraction of water first increases, and afterwards diminishes, the excitability. The *imbibition of water* diminishes the excitability. (b) Free alkalies, mineral acids (not phosphoric), many organic acids (acetic, oxalic, tartaric, lactic), and most salts of the heavy metals. While the acids act as stimuli, only when they are somewhat concentrated, the caustic alkalies act in solutions of 0.8 to 0.1 per cent. (Kühne). Neutral potash salts in a concentrated form rapidly kill a nerve, but they do not excite it nearly so strongly as the soda compounds. Dilute solutions of the neutral potash salts, first increase and afterwards diminish it (Ranke). (c) Various substances—*e.g.*, dilute alcohol, ether, chloroform, bile, bile-salts, and sugar. These substances usually excite contractions, and afterwards rapidly kill the nerve. Ammonia (Eckhard), lime-water (Kühne), some metallic salts, carbon bisulphide and ethereal oils kill the nerve without exciting it—at least without producing any contraction in a frog's nerve-muscle preparation. Carbolic acid does the same, although, when applied directly to the spinal cord, it produces spasms. These substances excite the muscles, when they are directly applied to them. Tannic acid does not act as a stimulus either to nerve or muscle. As a general rule, the stimulating solutions must be stronger when applied to a nerve than to a muscle, in order that a contraction may be produced.

[If a nerve-muscle preparation of a frog's limb be made, and a straw-flag (p. 635) attached to the toes, while the femur is fixed in a clamp, and its nerve be then dipped in a saturated solution of common salt, the toes soon begin to twitch, and by-and-bye the whole limb becomes tetanic, and thus keeps the straw-flag extended. The effect of fluid on a muscle or nerve is easily tested by fixing the muscle in a clamp, while a drop of the fluid is placed on a greased surface, which gives it a convex form (Kühne). The end of the muscle or nerve is then brought into contact with the cupola of the drop.]

4. The physiological or normal stimulus excites the nerves in the normal, intact body. Its nature is entirely unknown. The "nerve-motion" thereby set up travels either in a "centrifugal" or outgoing direction, from the central nervous system, giving rise to motion, inhibition of motion, or secretion; or in a "centripetal" or ingoing direction, from the specific *end-organs* of the nerves of the special senses or the sensory nerves. In the latter case, the impulse reaches the central organs, where it may excite sensation or perception, or it may be transferred to the motor areas and be conducted in a centrifugal direction, constituting a "reflex" stimulation (§ 360). A single physiological nerve impulse travels more slowly than that excited by the momentary

application of an induction shock (Lovèn, v. Kries); it may even last as long as $\frac{1}{3}$ second (v. Kries).

5. **Electrical Stimuli.**—The electrical current acts most powerfully upon the nerves, at the moment when it is applied, and at the moment when it ceases (§ 336); in a similar way, any increase or decrease in the strength of a constant current acts as a stimulus. If an electrical current be applied to a nerve, and its strength be very gradually increased or diminished, then the visible signs of stimulation of the nerve are very slight. As a general rule, the stimulation is more energetic, the more rapid the variations of the strength of the current applied to the nerve, *i.e.*, the more suddenly the *intensity* of the stimulating current is increased or diminished (du Bois-Reymond). An electrical current, in order to stimulate a nerve, must act at least during 0.0015 second (Fick, 1863, König); shocks of shorter duration have no effect. If the duration of the closing shock of a constant current be so arranged, that it is just too short to be active, then it merely requires to last 1.3–2 times longer to produce the most complete effect (Grünhagen).

The electrical current is most active when it flows in the *long axis* of the nerve; it is inactive when applied vertically to the axis of the nerve (Galvani, J. Albrecht, A. Meyer). Similarly, muscles are incomparably less excited by transverse than by longitudinal currents (Giuffrè).

The greater the length of nerve traversed by the current, the less the stimulus that is required (Pfaff, Marcuse, Tschirjew).

Constant Current.—If the constant current be used as a nervous stimulus, the stimulating effect on the *sensory nerves* is most marked at the moment of closing and opening [or breaking] the current; during the time the current passes, only slight excitement is perceived, but even under these circumstances, very strong currents may cause very considerable, and even unbearable sensations. If a constant current be applied to a *motor nerve*, the greatest effect is produced when the current is closed [*closing shock*], and when it is opened [*opening shock*]. But while the current is passing, the stimulation does not cease completely (Wundt), for, with a certain strength of stimulus, the muscle remains in a state of tetanus (*galvanotonus* or "*closing-tetanus*")—(Pflüger). With strong currents this tetanus does not appear, chiefly because the current diminishes the excitability of the nerves, and thus develops resistance, which prevents the stimulus from reaching the muscle. According to Hermann, a descending current applied to the nerve, at a distance from the muscles, causes this tetanus more readily, while an ascending current causes it more readily when the current is closed near the muscle. The constant current is said by Grützner to have no effect on *vaso-motor* and *secretory* fibres.

Over-maximal Contraction.—By gradually increasing the strength of the electrical stimulus applied to a motor nerve, Fick observed that, the muscular contractions (height of the lift) at first increased proportionally to the increase of the stimulus, until a maximal contraction was obtained. If the strength of the stimulus be increased still further, another increase of the contraction above the first reached maximum is obtained. This is called an “*over-maximal contraction*.”

Tetanus.—If *single shocks of short duration* be rapidly applied after each other to a nerve, tetanus in the corresponding muscle is produced (§ 298, III.).

A motor nerve is excited by a feebler electrical stimulus than the muscle-substance. This is proved by the fact that, a feebler stimulus suffices to excite a muscle when applied to the nerve than when it is applied to the muscle directly (p. 636), as occurs when the terminations of the motor nerves are paralysed by curara (Rosenthal).

Soltmann found that, the excitability of the motor nerves of new-born animals for electrical stimuli is less than in adults. The excitability increases until the 10th–12th week (dog), and in the human subject, until the 5th–10th month.

Unequal Excitability.—Under certain circumstances, the nearer the part of the motor nerve stimulated lies to the central nervous system, the greater is the effect produced (contraction); [or, what is the same thing, the further the point of a nerve which is stimulated is from the muscle, the stimulus being the same, the greater is the contraction]. According to Fleischl, all parts of the nerve are equally excitable for *chemical* stimuli. Further, it is said that the higher placed parts of a nerve are more excitable only when the stimulating current passes in a descending direction; the reverse is the case when the current ascends (Hermann, Fleischl). On stimulating a *sensory* nerve, Rutherford and Hällstén found, that the reflex contraction was greater the nearer the point stimulated was to the central nervous system.

Unequal Excitability in the same Nerve.—Nerve-fibres, even when functionally the same and included in the same nerve-trunk, are not all equally excitable. Thus, feeble stimulation of the sciatic nerve of a frog causes contraction of the flexor-muscles, while it requires a stronger stimulus to produce contraction of the extensors (Ritter, 1805, Rollett). According to Ritter, the nerves for the flexors die first.

Direct stimulation of the muscles in curarised animals shows that, the flexors contract with a feebler stimulus (but also fatigue sooner) than the extensors; the pale muscles of the rabbit are also more excitable than the red. As a rule, poisons affect the flexors sooner than the extensors. In some muscles, some pale fibres are present, and they are more excitable than the red (Grützner)—(§ 298).

Unipolar Stimulation.—If *one* electrode of an induction apparatus be applied to a nerve, it may act as a stimulus. Du Bois-Reymond has called this “*unipolar induction action*.” It is due to the movement

of the electric current to and from the free-ends of the open induction current at the moment of induction. [Unipolar induction is more apt to occur with the opening than the closing shock, because the former is more intense.]

Upon muscle, electrical stimuli act quite as they do upon nerves. Electrical currents of *very short* duration have no effect upon muscles whose nerves are paralysed by curara (Brücke), and the same is true of greatly fatigued muscles, or muscles about to die or greatly weakened by diseased conditions (§ 399).

325. Diminution of the Excitability—Degeneration and Regeneration of Nerves.

1. **Normal Nutrition.**—The continuance of the normal excitability in the nerves of the body depends upon the maintenance of the *normal nutrition* of the nerves themselves. Insufficient nutrition causes in the first instance increased excitability, and if the condition be continued, the excitability is diminished (§ 339, I.).

When the physician meets with the *signs of increased excitability of the nerves*, under bad or abnormal conditions of nutrition, this is to be regarded as the beginning of the stage of decrease of the nerve energy. Invigorating measures are required.

If the *terminal nervous apparatus* be subjected to a temporary disturbance of its nutrition, the return of the normal nutritive process is heralded by a more or less marked stage of excitement. The more excitable the nervous apparatus, the shorter must be the duration of the disturbance of nutrition—*e.g.*, cutting off the arterial blood supply, or interfering with the respiration.

2. **Fatigue.**—Continued *excessive stimulation* of a nerve, without sufficient intervals of repose, causes *fatigue* of the nerve, and by exhaustion, rapidly diminishes the excitability. A nerve is more slowly fatigued than a muscle (Bernstein), but it recovers more slowly.

Recovery.—When a nerve recovers, at first it does so slowly, then more rapidly, and afterwards again more slowly. If recovery does not occur within half an hour, after a frog's nerve has been subjected to very long and intense stimulation, it will not take place at all (Bernstein).

3. **Continued inaction** of a nerve diminishes, and may ultimately abolish the excitability.

Thus the *central* ends of divided sensory nerves, after amputation of a limb, lose their excitability, although the nerves are still connected with the central nervous system, because the end-organs through which they were normally excited have been removed.

4. Separation from their Nerve-Centres.—The nerve-fibres remain in a condition of normal nutrition only when they are directly connected with their *centre*, which governs the *nutritive processes* within the nerve. If a nerve within the body be separated from its *centre*—either by section of the nerve or compressing it—within a short time, it loses its

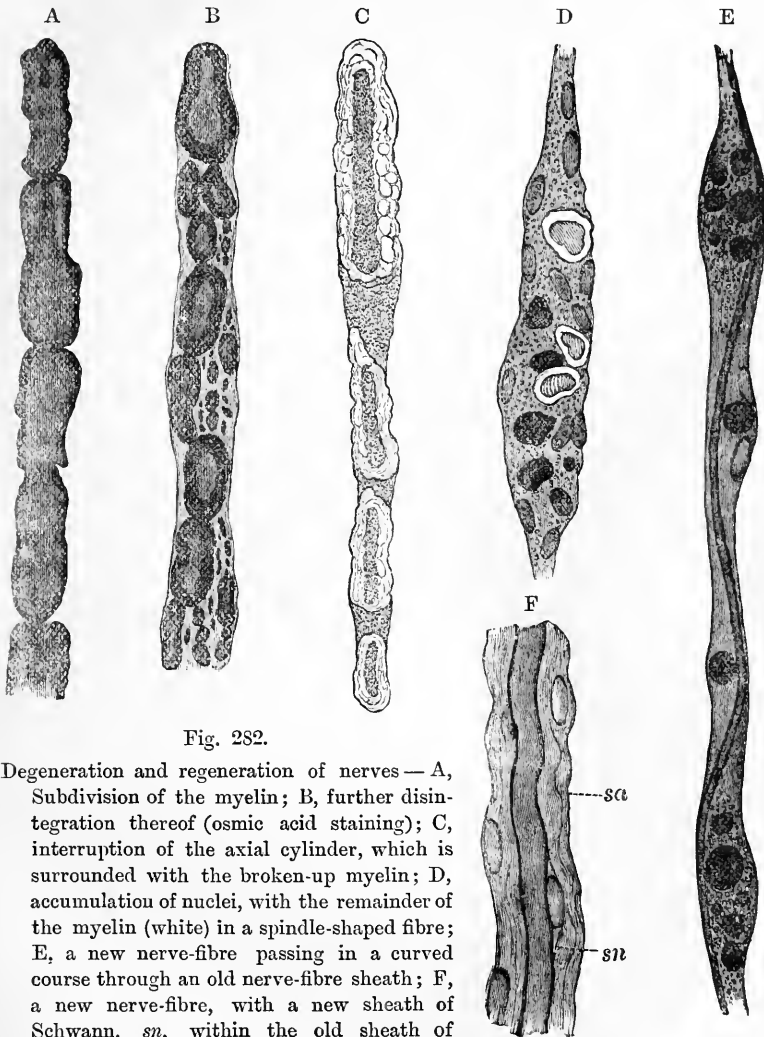

Fig. 282.

Degeneration and regeneration of nerves—A, Subdivision of the myelin; B, further disintegration thereof (osmic acid staining); C, interruption of the axial cylinder, which is surrounded with the broken-up myelin; D, accumulation of nuclei, with the remainder of the myelin (white) in a spindle-shaped fibre; E, a new nerve-fibre passing in a curved course through an old nerve-fibre sheath; F, a new nerve-fibre, with a new sheath of Schwann, *sn*, within the old sheath of Schwann, *sa* (Eichhorst).

excitability, and the *peripheral* end undergoes fatty degeneration, which begins in 4–6 days in warm-blooded animals, and after a longer time, in cold-blooded ones (Joh. Müller). See also the changes of the excitability during this condition, the so-called "*Reaction of degeneration*".

(§ 339). If the *sensory* nerve-fibres of the root of a spinal nerve be divided on the central side of the ganglion, the fibres on the peripheral side do not degenerate, for the ganglion is the trophic or nutritive centre for the sensory nerves, but the fibres still in connection with the cord degenerate (Waller, Bidder).

[Wallerian Law of Degeneration.—If a spinal nerve be divided, the peripheral part of the nerve and its branches, including the sensory and motor fibres, degenerate completely (Fig. 283, A), while the central parts of the nerve remain unaltered. If the *anterior root* of a spinal nerve alone be divided, before it joins the posterior root, all the peripheral nerve-fibres connected with the anterior root degenerate (Fig. 283, B), so that in the nerve of distribution only the motor fibres degenerate. The portion of the nerve root which remains attached to the cord does not degenerate. If the *posterior root* alone be divided, between the spinal cord and the ganglion, the effect is reversed, the part of the nerve root lying between the section and the spinal cord degenerates, while the part of the nerve connected with the ganglion does not degenerate (Fig. 283, C). The central fibres degenerate because they are separated from the ganglion. If the ganglion be

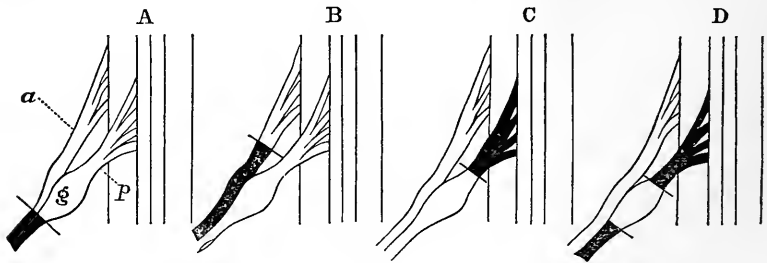

Fig. 283.

Diagram of the roots of a spinal nerve showing the effect of section (the black parts represent the degenerated parts)—A, section of the nerve-trunk beyond the ganglion; B, section of the anterior root, and C, of the posterior; D, excision of the ganglion; *a*, anterior, *p*, posterior root; *g*, ganglion (after Dalton).

excised, or if separated, as in Fig. 283, D, both the central and peripheral parts of the posterior root degenerate. These experiments of Waller show that, the fibres of the anterior and posterior roots are governed by different centres of nutrition or "trophic centres." As the anterior root degenerates, when it is separated from the cord, and the posterior when it is separated from its own ganglion, it is assumed that, the trophic centre for the fibres of the anterior root lies in the multipolar nerve-cells of the anterior horn of the grey matter of the spinal cord, while that for the fibres of the posterior root lies in

the cells of the ganglion placed on it. The nature of this supposed trophic influence is entirely unknown.]

Traumatic Degeneration.—Both ends of the nerve at the point of section immediately begin to undergo "*traumatic degeneration.*" (In the frog on the 1st and 2nd day.) After a time, neither the myelin nor axis cylinder are distinguishable (Schiff). According to Engelmann, this condition extends only to the nearest node of Ranvier, and afterwards the so-called "*fatty degeneration*" begins. The process of "*fatty*" degeneration begins simultaneously in the whole peripheral portion; the white substance of Schwann breaks up into masses (Fig. 282, A), just as it does after death, in microscopic preparations; afterwards, the myelin forms globules and round masses (B), the axial cylinder is compressed or constricted, and is ultimately broken across (C) in many places (7th day). The nerve-fibre seems to break up into two substances—one fatty, the other proteid in constitution (S. Mayer), the fat being absorbed. The nuclei of Schwann's sheath swell up and proliferate (D—until the 10th day). According to Ranvier, the nuclei of the interannular segments and their surrounding protoplasm proliferate, and ultimately interrupt the continuity of the axis cylinder and the myelin. They then undergo considerable development with simultaneous disappearance of the medulla and axis cylinder, or at least the fatty substances formed by their degeneration, so that the nerve-fibres look like fibres of connective-tissue. [According to this view, the process is in part an *active* one, due to the growth of the nerve-corpuscles breaking up the contents of the neurilemma, which then ultimately undergo chemical degenerative changes.] According to Ranvier, Tizzoni, and others, leucocytes wander into the cut ends of the nerves, and also at Ranvier's nodes, insinuating themselves into the nerve-fibres, where they take myelin into their bodies, and subject it to certain changes. [These cells are best revealed by the action of osmic acid, which blackens any myelin particles in their interior.]

Degeneration also takes place in the motorial end-plates, beginning first in the non-medullated branches, then in the terminal fibrils, and lastly, in the nerve-trunks (Gessler).

Regeneration of Nerves.—In order that regeneration of a divided nerve may take place (Cruikshank, 1795), the divided ends of the nerve must be brought into contact (p. 495). In man this is done by means of sutures.

About the middle of the fourth week, small clear bands appear within the neurilemma, winding between the nuclei and the remains of the myelin, (E). They soon become wider, and receive myelin with incisures, and nodes, and a sheath of Schwann (2nd-3rd month—F). The regeneration process takes place in each interannular segment, while the individual segments unite end to end at the nodes of Ranvier (§ 321, I., 5). On this view, each nerve-segment of the fibre corresponds to a "cell-unit" (E. Neumann, Eichhorst). The same process occurs in nerves *ligatured* in their course. *Several* new fibres may be formed within *one* old nerve-sheath. The divided axis cylinders of the *central* end of the nerve begin to grow about the 14th day, until they meet the newly formed ones, with which they unite.

[Primary and Secondary Nerve Suture.—Numerous experiments on animals and man have established the fact that, immediate or primary suture of a nerve, after it is divided, either accidentally or intentionally, hastens reunion and regeneration, and accelerates the restoration of function. Secondary suture—*i.e.*, bringing the ends together long after the nerve has been divided, has been practised with success. Surgeons have recorded cases where the function was restored after division had taken place for 3-16 months, and even longer, and in most cases the sensibility was restored first, the average time being 2-4 weeks. Motion is recovered much later. The ends of the nerve should be stitched to each other with catgut,

the muscles at the same time being kept from becoming atrophied by electrical stimulation and the systematic use of massage (p. 677).]

The central end of a divided motor nerve may unite with the peripheral end of another and still conduct impulses (Rava).

[There seems to be no doubt that sensory fibres will reunite with sensory fibres, and motor fibres with motor fibres, and the regenerated nerve will, in the former case, conduct sensory impulses, and the latter motor impulses. There is very considerable diversity of opinion, however, as to the regeneration or union of sensory with motor fibres. Paul Bert made the following experiment:—He stitched the tail of a rat into the animal's back, and after union had taken place, he cut the tail from the body at the root, so that the tail, as it were, grew out of the animal's back, broad end uppermost. On irritating the end of the tail, which was formerly the root, the animal gave signs of pain. This experiment shows that nerve-fibres can conduct impulses in both directions. One of two things must have occurred. Either the motor fibres, which normally carried impulses down the tail, now convey them in the opposite direction, and convey them to sensory fibres with which they have united; or the sensory fibres, which normally conducted impulses from the tip upwards, now carry them in the opposite direction. If the former were actually what happened it would show that nerve-fibres of different function do unite. Reichert asserts that he has succeeded in uniting the hypoglossal with the vagus in the dog.]

Trophic Centres.—The regeneration of the nerves seems to take place under the influence of the nerve centres, which act as their nutritive, or trophic centres. Nerves permanently separated from these centres never regenerate.

During the regeneration of a *mixed* nerve, sensibility is restored first, subsequently *voluntary* motion, and lastly, the movements of the muscles, when their motor nerves are stimulated directly (Schiff, Erb, v. Ziemssen, and others).

Wallerian Method of Investigation.—As the *peripheral* end of a nerve undergoes degeneration after section, we use this method for determining the course of nerve-fibres in a complex arrangement of nerves. The course of special nerve-fibres may be ascertained by tracing the degeneration tract (Waller, Budge). If after section, reunion or regeneration of a motor nerve does not take place, the muscle supplied by this nerve ultimately undergoes fatty degeneration.

5. Certain poisons, such as *veratrin*, at first increase the excitability of the nerves, and afterwards abolish it; with some other poisons, the abolition of the excitability passes off very rapidly, *e.g.*, curara. Conium, cynoglossum, iodide of methylstrychnin, and iodide of æthylstrychnin have a similar action.

If the nerve or muscle of a frog be placed in a solution of the poison, we obtain a different effect from that which results when the poison is injected into the body of the animal. Atropin diminishes the excitability of a nerve-muscle preparation of the frog without causing any previous increase, while alcohol, ether, and chloroform increase and then diminish the excitability (Mommssen).

6. **Modifying Conditions.**—Under the action of various operations, *e.g.*, *compressing* a nerve [so as not absolutely to sever the physio-

logical continuity], it has been found that, voluntary impulses or stimuli applied *above* the compressed spot, give rise to impulses which are conducted through the nerve, and in the case of a motor nerve cause contraction of the muscles, whilst the excitability of the parts *below* the injured spot is greatly diminished (Schiff). In a similar manner, it is found that the nerves of animals poisoned with CO₂, curara or coniin, sometimes even the nerves of paralysed limbs in man, are not excitable to direct stimuli, while they are capable of conducting impressions coming from the central nervous system (Duchenne, v. Ziemssen, Erb).

7. Ritter-Valli Law.—If a nerve be separated from its centre, or if the centre dies, the excitability of the nerve is *increased*; the increase begins at the central end, and travels towards the periphery—the excitability then *falls* until it disappears entirely. This process takes place more rapidly in the central than in the peripheral part of the nerve, so that the peripheral end of a nerve separated from its centre remains excitable for a longer time than the central end.

The *rapidity of the transmission* of impulses in a nerve is increased when the excitability is increased, but it is lessened when the excitability is diminished. In the latter condition, an electrical stimulus must last longer, in order to be effective; hence, rapid induction shocks may not produce any effect.

The *law of contraction* also undergoes some modification in the different stages of the changes of excitability (§ 336, II.).

8. Excitable Points.—Many nerves are more excitable at certain parts of their course than at others, and the excitability may last longer at these parts. One of these parts is the upper third of the sciatic nerve of a frog, just where a branch is given off (Budge, Heidenhain).

This increased excitability may be due to injury to the nerve, in preparing it for experiment. After section or compression of a nerve, all electrical currents employed to stimulate the nerve are far more active when the direction of the current passes away from the point of injury, than when it passes in the opposite direction. This is due to the fact that the current produced in the nerve (§ 331, 5) after the lesion, is added to the stimulation current. Even in intact nerves—sciatic of a frog (v. Fleischl)—where the nerve ends at the periphery or at the centre, or where large branches are given off, there are points which behave in the same way as those points where a lesion has taken place (Grützner and Moschner).

Death of a Nerve.—In a *dead* nerve the excitability is entirely abolished, death taking place according to the Ritter-Valli law, from the centre towards the periphery. The reaction of a dead nerve has been found by some observers to be acid (p. 719).

The functions of the brain cease immediately death takes place, while the vital functions of the spinal cord, especially of the white matter, last for a short time; the large nerve-trunks gradually die, then the nerves of the extensor muscles,

those of the flexors after 3-4 hours; while the sympathetic fibres retain their excitability longest, those of the intestine even for 10 hours (Onimus)—compare § 295. The nerves of a dead frog may remain excitable for several days, provided the animal be kept in a cool place.

Electro-physiology.

BEFORE beginning the study of electro-physiology, the student ought to read and study carefully the following short preliminary remarks on the physics of this question.

326. Physical Preliminary Statements—The Galvanic Current.

1. **Electro-motive Force.**—If two of the under-mentioned bodies be brought into direct contact, in one of them positive electricity, and in the other negative electricity, can be detected. The cause of this phenomenon is the *electro-motive force*. The electro-motive substances may be arranged in a series of the **first class**, so that, if the first-mentioned substance be brought into contact with any of the other bodies, the first substance is negatively, the last positively electrified. This series is: — carbon, platinum, gold, silver, copper, iron, tin, lead, zinc +.

The **amount** of the electro-motive force produced by the contact of two of these bodies is greater, the wider the bodies are apart in the series. The contact of the bodies may take place at one or more points. If several of the bodies of this series be arranged in a pile, the electrical tension thereby produced is just as great as if the two extreme bodies were brought into contact, the intermediate ones being left out.

2. The nature of the two electricities is readily determined by placing *one* of the bodies of the series in contact *with a fluid*. If zinc be placed in pure or acidulated water, the zinc is + (positive) and the water — (negative). If copper be taken instead of zinc, the copper is + but the fluid —. Experiment shows that those metals, in contact with fluid, are negatively electrified most strongly which are most acted on chemically by the fluid in which they are placed. Each such combination affords a constant difference of tension or potential. The tension [or power of overcoming resistance] of the amount of electricity obtained from both bodies depends upon the size of the surfaces in contact. The fluids, *e.g.*, the solutions of acids, alkalies, or salts, are called exciters of electricity of the **second class**. They do not form among themselves a definite series with different tensions. When placed in these fluids, the metals lying next the + end of the above series, especially zinc, are most strongly electrified negatively, and to a less extent those lying nearer the — end of the series.

3. **Galvanic Battery.**—If two different exciters of the first class be placed in fluid, without the bodies coming into contact, *e.g.*, zinc and copper, the projecting end of the (negative) zinc shows free negative electricity, while the free end of the (positive) copper shows free positive electricity. Such a combination of two electromotors of the first class with an electromotor of the second class is called a *galvanic battery*. As long as the two metals in the fluid are kept separate,

the circuit is said to be *open*, but as soon as the free projecting ends of the metals are connected outside the fluid, *e.g.*, by a copper wire, the circuit or current is *closed*, and a *galvanic* or *constant current* of electricity is obtained.

The galvanic current has resistance to encounter in its course, which is called "*conduction resistance*" (*W*). It is directly proportional: 1, to the *length* (*l*) of the circuit; 2, and with the same length of circuit, inversely as the section (*q*) of the same; and 3, it also depends on the molecular properties of the conducting material (*specific conduction resistance* = *s*), so that the conduction resistance, $W = (s \cdot l) : q$.

The resistance to conduction increases with the increase of the temperature of the metals, but diminishes under similar conditions with fluids.

Ohm's Law.—The strength of a galvanic current (*S*), or the amount of electricity passing through the closed circuit, is proportional to the electro-motive force (*E*)—or the electrical tension, but inversely proportional to the total resistance to conduction (*L*)—

So that $S = E : L$ (Ohm's Law, 1827).

The total resistance to conduction, however, in a closed circuit is composed of—1, The resistance outside the battery ("*extraordinary resistance*"); and 2, the resistance within the battery itself ("*essential resistance*"). The specific resistance to conduction is very variable in different substances: it is relatively small in metals (*e.g.*, for copper = 1, iron = 6.4, German silver = 12), but very great in fluids, (*e.g.*, for a concentrated solution of common salt 6,515,000, for a concentrated solution of copper sulphate 10,963,600). It is also very great in *animal tissues*, almost a million times greater than in metals. When the current is passed *transversely* to the direction of the fibres of a *muscle*, the resistance is nearly nine times as great as when the current passes in the direction of the fibres (Hermann)—a condition which disappears in rigor mortis. In *nerves*, the resistance longitudinally is two and a-half million times greater than in mercury, transversely about twelve million times (Hermann). According to Harless, the resistance to conduction in muscles is only half as great as that in nerves; but, according to Ranke, living muscle has a conducting power twice less than an excised muscle. Tetanus and rigor mortis (du Bois-Reymond) diminish the resistance in muscle. A living nerve is the best conductor of electricity amongst animal tissues (M. Benedikt)—compare § 286.

It follows from Ohm's law that—I, If there is very great resistance to the current outside the battery [*i.e.*, between the electrodes], as in the case when a nerve or a muscle lies on the electrodes, the strength of the current can only be increased by increasing the number of the electro-motive elements. II. When, however, the extraordinary resistance is very small compared with that within the battery itself, the strength of the current cannot be increased by increasing the number of the elements, but only by increasing the surfaces of the plates in the battery.

Strength and Density.—We must carefully distinguish the *strength* (intensity) of the current from its *density*. As the same amount of electricity always flows through any given transverse section of the circuit, then, if the size of the transverse section of the circuit varies, the electricity must be of *greater density* in the narrower parts, and it is evident that the density will be less where the transverse section is greater. Let *S* = the strength of the current, and *q* the transverse section of the given part of the circuit, then the density (*d*) at the latter part is $d = S : q$.

If the galvanic current passing from the positive pole of a battery be divided into two or more streams, which are again reunited at the other pole, then the sum of the strength of all the streams is equal to the strength of the undivided stream. If, however, the different streams are different as regards length, section, and material, then the strength of the current passing in each of the streams is inversely proportional to the resistance to the conduction.

Du Bois-Reymond's Rheocord.—This instrument, constructed on the prin-

ciple of the "secondary or short circuit," enables us to graduate the strength of a galvanic current to any required degree, for the stimulation of nerve and muscle.

From the two poles (Fig. 284, *a*, *b*) of a constant battery there are two conducting wires (*a*, *c* and *d*, *b*), which go to the nerve of a frog's nerve-muscle preparation (*F*). The portion of nerve (*c*, *d*) introduced into this circuit (*a*, *c*, *d*, *b*)

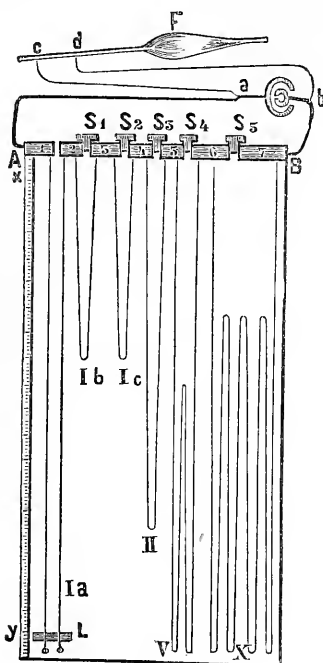

Fig. 284.

Scheme of du Bois-Reymond's Rheocord.

offers *very great* resistance. The second stream or secondary circuit (*a*, *A*, *b*, *B*) conducted from *a* and *b* passes through a thick brass plate (*A*, *B*), consisting of seven pieces of brass (1-7) placed end to end, but not in contact. They can all, with the exception of 1 and 2, be made to form a continuous conductor, by placing in the spaces between them the brass plugs (*S*₁ to *S*₅). Evidently, with the arrangement shown in Fig. 284, only a minimal part of the current will pass through the nerve (*c*, *d*) owing to the very great resistance in it, while by far the greatest part will pass through the good conducting medium of brass (*A*, *L*, *B*). If new *resistance* be introduced into this circuit, then the *a*, *c*, *d*, *b* stream will be strengthened. This resistance can be introduced into the latter circuit, by means of the thin wires marked *Ia*, *Ib*, *Ic*, *II*, *V*, *X*. Suppose all the brass plugs from *S*₁ to *S*₅ to be removed, then the current entering at *A* must traverse the whole system of thin wires. Thus, there is more resistance to the passage of this current, so that the current through the nerve must be strengthened. If only one brass plug be taken out, then the current passes through only the corresponding length of wire. The resistances offered by the different lengths of wire from *Ia* to *X* are so arranged that *Ia*, *Ib*, and *Ic* each represent a unit of resistance; *II*, double; *V*, five times; and *X*, ten times the resistance. The length of wire, *Ia*, can also be shortened by the movable *bridge* (*L*) [composed of a small tube filled with mercury, through which the wires pass], the scale (*x*, *y*) indicating the length of the resistance wires. It is evident that, by means of the bridge, and by the method of using the brass plugs, the apparatus can be graduated to yield very variable currents for stimulating nerve or muscle. When the bridge (*L*) is pushed hard up to 1, 2, the current passes directly from *A* to *B*, and not through the thin wires (*I*, *a*).

The **rheostat** is another instrument used to vary the resistance of a galvanic current [Wheatstone].

327. Action of the Galvanic Current on a Magnetic Needle—The Galvanometer.

In 1820, Oersted of Copenhagen, found that a *magnetic needle* suspended in the magnetic meridian was deflected by a constant current of electricity passed along

a wire parallel to it. [The side to which the north pole is deflected depends upon the direction of the current, and whether it passes above or below the needle.]

Ampère's Rule.—Ampère has given a simple rule for determining the direction. If an observer be placed parallel to and facing the needle, and if the current be passing from his feet to his head, then the north pole of the needle will always be deflected to the *left*, and the south pole in the opposite direction. The effect exerted by the constant current acts always in a direction towards the so-called electro-magnetic plane. The latter is the plane passing through the north pole of the needle, and two points in the straight wire running parallel with the needle. The force of the constant current, which causes the deflection of the magnetic needle, is proportional to the sine of the angle between the electro-magnetic plane and the plane of vibration of the needle.

Multiplicator [or Multiplier].—The deflection of the needle caused by the constant current may be increased by coiling the conducting wire *many* times in the same direction on a rectangular frame, or merely around and in the same direction as the needle, [provided that each turn of the wire be properly insulated from the other]. An instrument constructed on this principle is called a *multiplicator*. The greater the number of turns of the wire the greater is the angle of deflection of the needle, although the deflection is not directly proportional, as the several turns or coils are not at the same distance from, or in the same position as, the needle. By means of the multiplier we may detect the presence [and also the amount and direction] of *feeble currents*. [The instrument is now termed a **Galvanometer**.]

Experience has shown that, when great resistance (as in animal tissues), is opposed to the weak galvanic currents, we must use a very large number of turns of thin wire round the needle. If, however, the resistance in the circuit is only small—*e.g.*, in thermo-electrical arrangements, a few turns of a *thick* wire round the needle are sufficient.

The multiplier may be made more sensitive by *weakening the magnetic directive force of the needle*, which keeps it pointing to the north.

Galvanometer and Astatic Needles.—In the multiplier of Schweigger, used for physiological purposes, the tendency of the needle to point to the north is greatly weakened by using the astatic needles of Nobili. [A multiplier or galvanometer with a single magnetic needle, always requires comparatively strong currents to deflect the needle. The needle is continually acted upon by the directive magnetic influence of the earth, which tends to keep it in the magnetic meridian, and as soon as it is moved out of the magnetic meridian, the directive action of the earth tends to bring it back. Hence, such a simple form of galvanometer is not sufficiently sensitive for detecting feeble currents. In 1827, Nobili devised an astatic combination of needles, whereby the action of the earth's magnetism was diminished.] Two similar magnetic needles are united by a solid light piece of horn [or tortoise shell], and are so arranged that, the north pole of the one is placed over or opposite to the south pole of the other (Fig. 285). [If both needles are equally magnetised, then the earth's influence on the needle is neutralised, so that the needles no longer adjust themselves in the magnetic meridian; hence, such a system is called *astatic*.] As it is impossible to make both needles of absolutely equal magnetic strength, one needle is always stronger than the other. The difference, however, must not be so great, that the stronger needle points to the north, but only that the freely suspended system of needles forms a certain angle with the magnetic meridian, into which position the system always swings after it is deflected from this position. This angular deviation of the astatic system towards the magnetic meridian is called the "free deviation." The more perfectly an astatic condition is reached, the nearer the angle formed by the direction of the free deviation with the magnetic meridian becomes a right angle. The greater, therefore, the astatic condition, the astatic system will make the fewer vibrations in a given time, after

it has been deflected from its position. The duration of each single vibration is also very great. [Hence, when using a galvanometer, and adjusting its needle to zero, if the magnets dance about or move quickly, then the system is not sensitive, but a sensitive condition of the needles is indicated by a *slow* period of oscillation.]

In making a galvanometer, the turns of the wire must have the same direction as the needles. In Nobili's galvanometer, as improved by du Bois-Reymond, the upper needle swings above a card divided into degrees (Fig. 285), on which the extent of its deflection may be read off. Even the purest copper wire used for the coils round the needles always contains a trace of iron, which exerts an in-

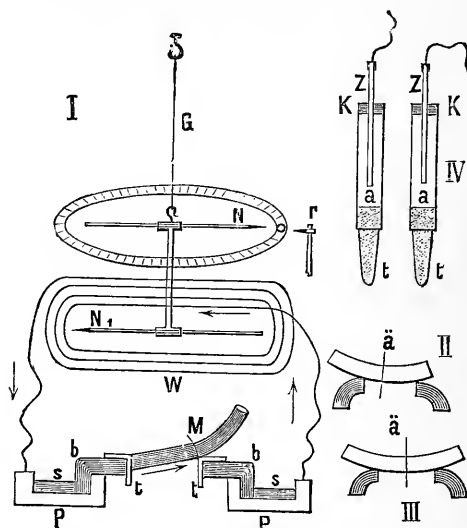

Fig. 285.

Scheme of the galvanometer for investigating electrical currents in muscle—N, N, astatic pair of needles suspended by the silk fibre, G; P, P, non-polarisable electrodes, containing zinc sulphate solution, s, and pads of blotting paper, b, covered with clay, t, t, on which the muscle, M, is placed; II and III, arrangements of the muscle on the electrodes; IV, non-polarisable electrodes; Z, zinc wire; K, cork; a, zinc sulphate solution; t, t, clay points.

fluence upon the needles. Hence, a small, fixed, directive or compensatory magnet (r) is placed near one of the poles of the upper needle to compensate for the action of the iron on the needles.

328. Electrolysis.

Electrolysis.—Every galvanic current which traverses a fluid conductor causes decomposition or *electrolysis* of the fluid. The decomposition products, called *ions*, accumulate at the *poles* (electrodes) in the fluid, the positive pole (+) being called the *anode* [*ανά*, up, *ὁδός*, a way], the negative pole (−) the *cathode* (*κατά*, down, *ὁδός*, a way). The *anions* accumulate at the anode and the *kations* at the cathode.

Transition Resistance.—When the decomposition products accumulate upon the electrodes, by their presence they either increase or diminish the resistance to

the electrical current. This is called *transition resistance*. If the resistance within the battery is thereby increased, the transition resistance is said to be *positive*; if diminished, *negative*.

Galvanic Polarisation.—The ions accumulated on the electrodes may also vary the strength of the current, by developing between the anions and kations a new galvanic current, just as occurs between two different bodies connected by a fluid medium. This phenomenon is called *galvanic polarisation*. Thus, when water is decomposed, the electrodes being of platinum, the oxygen (negative) accumulates at the + pole, and the hydrogen (positive) at the - pole. Usually the polarisation current has a direction *opposite* to the original current; hence, we speak of *negative polarisation*. When the two currents have the same direction, *positive polarisation* obtains.

Of course transition resistance and polarisation may occur together during electrolysis.

Test.—Polarisation, when present, may be so slight as not to be visible to the eye, but it may be detected thus: After a time exclude the primary source of the current, especially the element connected with the electrodes, and place the free projecting end of the electrodes in connection with a galvanometer, which will at once indicate by the deflection of its needle the presence of even the slightest polarisation.

Secondary Decompositions.—The ions excreted during electrolysis cause, especially at their moment of formation, secondary decompositions. With platinum electrodes in a solution of common salt, chlorine accumulates at the anode and sodium at the cathode, but the latter at once decomposes the water, and uses the oxygen of the water to oxidise itself, while the hydrogen is deposited secondarily upon the cathode.

The amount of polarisation increases, although only to a slight extent, with the *strength of the current*, while it is nearly proportional to the *increase of the temperature*.

The attempts to get rid of polarisation, which obviously must very soon alter the strength of the galvanic current, have led to the discovery of two important arrangements, viz., to the construction of **constant galvanic batteries** (Becquerel), and the so-called **non-polarisable electrodes** (du Bois-Reymond).

Constant Batteries, Elements, or Cells.—A perfectly constant element produces a *constant* current, *i.e.*, one remaining of equal strength by the ions produced by the electrodes being got rid off the moment they are formed, so that they cannot give rise to polarisation. For this purpose each of the substances from the tension series (p. 732) used, is placed in a special fluid; both fluids being separated by a porous septum (porcelain cylinder).

Grove's element has two metals and two fluids (Fig. 286). The zinc is in the form of a roll placed in dilute sulphuric acid [1 acid to 7 of water, which is contained in a glass, porcelain, or ebonite vessel]. The platinum is in contact with strong nitric acid [which is contained in a porous cell placed inside the roll of zinc]. The O, formed by the electrolysis and deposited on the zinc plate, forms zinc oxide, which is at once dissolved by the sulphuric acid. The hydrogen on the platinum unites at once with the nitric acid, which gives up O and forms nitrous acid and water, thus—

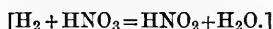

[Platinum is the + pole, and zinc the -.]

[Grove's battery is very powerful, but the nitrous fumes are very disagreeable and irritating; hence, these elements should be kept in a special, well-ventilated, recess in the laboratory, in an evaporating chamber, or under glass. The fumes also attack instruments.]

Bunsen's element is quite similar to Grove's, only a piece of compressed carbon is substituted for the platinum in contact with the nitric acid.

[The carbon is the + pole, the zinc -.]

Daniell's Element [1836].—[It consists of an outer vessel of glass or earthenware, and sometimes of metallic copper, filled with a saturated solution of cupric sulphate. A roll of copper, perforated with a few holes, is placed in the copper solution, and in order that the latter be kept saturated, and to supply the place of the copper used up by the battery when in action, there is a small shelf on the copper roll, on which are placed crystals of cupric sulphate. A porous earthenware vessel containing zinc in contact with dilute sulphuric acid (1 : 7) is placed within the copper cylinder. When the circuit is completed, the zinc is acted on, zinc sulphate

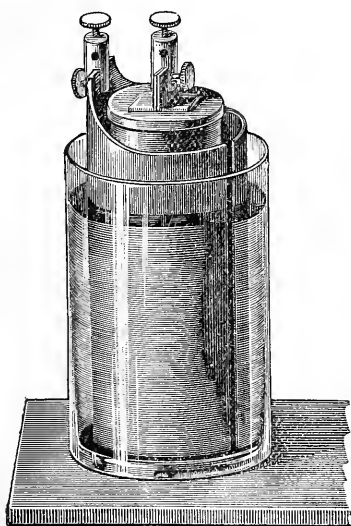

Fig. 286.

Large Grove's Element.

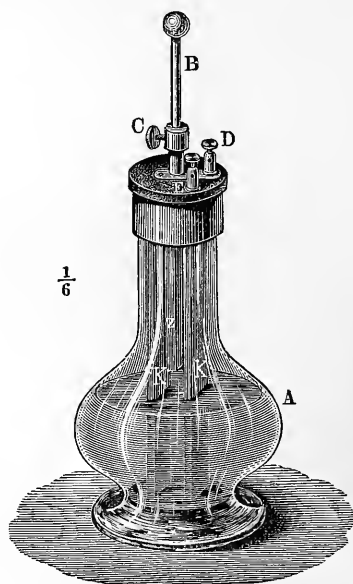

Fig. 287.

Grennet's Element—A, the glass vessel; K, K, carbon; Z, zinc; D, E, binding screw for the wires; B, rod to raise or depress the zinc in the fluid; G, screw to fix B.

being formed, and hydrogen liberated. The hydrogen in statu nascendi passes through the porous cell, reduces the cupric sulphate to metallic copper, which is precipitated on the copper cylinder, so that the latter is always kept bright and clean. The liberated sulphuric acid replaces that in contact with the zinc. Owing to the absence of polarisation, the Daniell is one of the most constant batteries, and is generally taken as a standard of comparison.]

[The copper is the + pole, zinc the -.]

Smee's Element.—There is only one fluid, viz., dilute sulphuric acid (1 : 7), in which the two metals, zinc and platinum, or zinc and platinised silver, are placed.

The platinum is the + pole, and zinc the -.]

[Grennet's, or the Bichromate Element.—It consists of one plate of zinc and two plates of compressed carbon in a fluid, which consists of bichromate of potash, sulphuric acid, and water. The fluid consists of 1 part of potassium bichromate dissolved in 8 parts of water, to which 1 part of sulphuric acid is added. Measure by *weight*].

[The cell consists of a wide-mouthed glass bottle (Fig. 287); the carbons remain in the fluid, while the zinc can be raised or depressed. When not in action, the zinc, which is attached to a rod (B), is lifted out of the fluid, and hence this battery is very convenient for purposes of demonstration, although it is not a very constant battery. When in action, the zinc is acted on by the sulphuric acid, hydrogen being liberated, which reduces the bichromate of potash.

The carbon is the + pole, and the zinc the - J.

Leclanché Element (Fig. 288) consists of an outer glass vessel containing

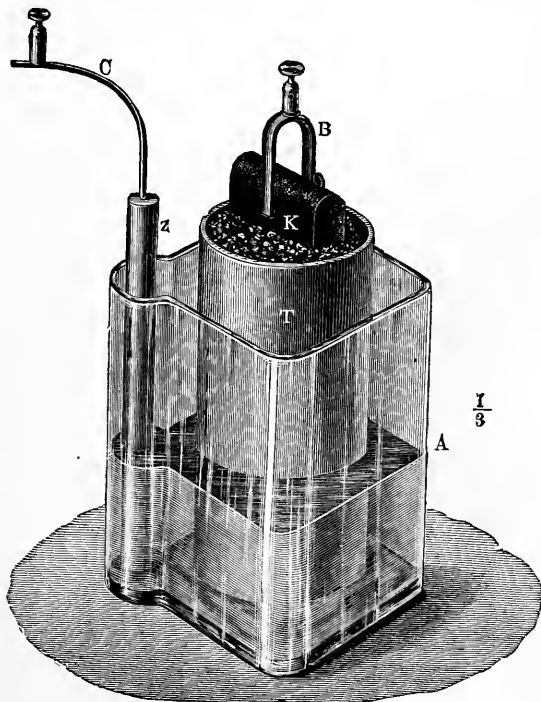

Fig. 288.

Leclanché's Element—A, outer vessel ; T, porous cylinder, containing K, carbon ·
B, binding screw ; Z, zinc ; C, binding screw of negative pole.

zinc in a solution of ammonium chloride, while the porous cell contains compressed carbon in a fluid mixture of black oxide of manganese and carbon. It is most frequently used for electric bells, as its feeble current lasts for a long time.

The carbon is the + pole, and the zinc the - J.

Non-polarisable Electrodes.—If a constant current be applied to moist animal tissues, *e.g.*, nerve or muscle, by means of ordinary electrodes composed either of copper or platinum, of course electrolysis must occur, and in consequence

thereof polarisation takes place. In order to avoid this, *non-polarisable* electrodes (Figs. 285 and 289) are used. The researches of Regnault, Matteucci, and du Bois-Reymond have proved that, such electrodes can be made by taking two pieces of

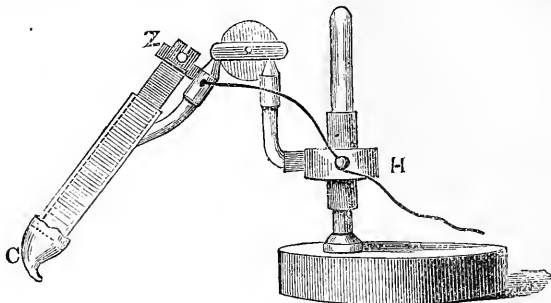

Fig. 289.

Non-polarisable electrode of du Bois-Reymond—Z, zinc; H, movable support; C, clay point—the whole on a universal joint (Elliott Brothers).

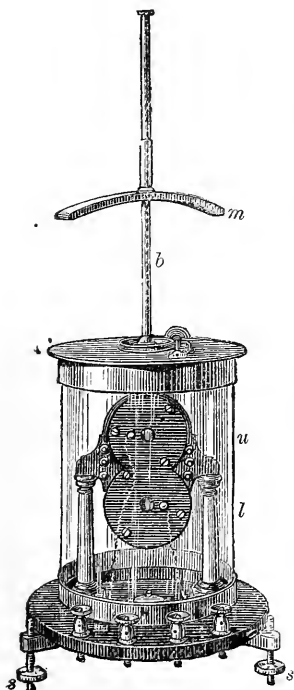

Fig. 290.

Sir William Thomson's reflecting galvanometer—*u*, upper, *l*, lower coil; *s*, *s*, levelling screws; *m*, magnet on a brass support, *b* (Elliott Brothers).

carefully amalgamated pure zinc wire (*z*, *z*), and dipping these in a saturated solution of zinc sulphate contained in tubes (*a*, *a*), their lower ends being closed by means of modeller's clay (*t*, *t*), moistened with 0.6 per cent. normal saline solution. The contact of the tissues with these electrodes does not give rise to polarity.

Arrangement for the Muscle- or Nerve-Current.—In order to investigate the electrical currents of nerve or muscle, the tissue must be placed on non-polarisable electrodes, which may either have the form described above, or the original form used by du Bois-Reymond (Fig. 285). The last consists of two zinc troughs (*p*, *p*) thoroughly amalgamated inside, insulated on vulcanite, and filled with a saturated solution of zinc sulphate (*s*, *s*). In each trough is placed a thick pad or cushion of white blotting paper (*b*, *b*) saturated with the same fluid [*deriving cushions*]. [The cushions consist of many layers, almost sufficient to fill the trough, and they are kept together by a thread. To prevent the action of the zinc sulphate upon the tissue, each cushion is covered with a thin layer of modeller's clay (*t*, *t*), moistened with 0.6 per cent. saline solution, which is a good conductor [*clay guard*]. The clay guard prevents the action of the solution upon the tissue. Connected with the electrodes are a pair of binding screws, whereby the apparatus is connected with the galvanometer (Fig. 285).]

Reflecting Galvanometer.—The form of galvanometer now used in this country for physiological purposes, is that of Sir William Thomson (Fig. 290). In Germany, Wiedemann's form is more commonly used. In Thomson's instrument,

the astatic needles are very light, and connected to each other by a piece of aluminium, and each set of needles is surrounded by a separate coil of wire, the lower coil (*l*) winding in a direction opposite to that of the upper (*u*). A small round, light, slightly concave mirror is fixed to the upper set of needles. The needles are suspended by a delicate silk fibril, and they can be raised or lowered as required by means of a small milled head. When the milled head is raised, the system of needles swings freely. The coils are protected by a glass shade, and the whole stands on a vulcanite base, which is levelled by three screws (*s*, *s*). On a brass rod (*b*) is a feeble magnet (*m*), which is used to give an artificial meridian. The magnet (*m*) can be raised or lowered by means of a milled head].

[Lamp and Scale.—When the instrument is to be used, place it so that the coils face east and west. At three feet distant, from the front of the galvanometer, facing west, is placed the lamp and scale (Fig. 291). There is a small vertical slit

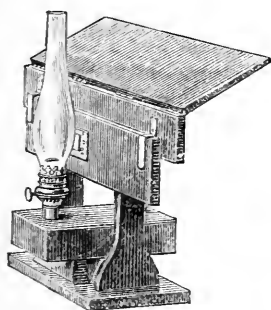

Fig. 291.

Lamp and Scale for Sir William Thomson's Galvanometer.

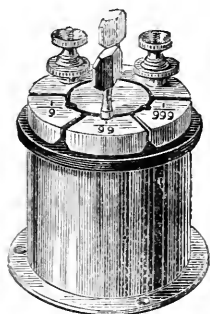

Fig. 292.

Shunt for Galvanometer.
(Elliott Brothers.)

in front of the lamp, and the image of this slip is projected on the mirror attached to the upper needles, and by it is reflected on to the paper scale fixed just above the slit. The spot of light is focussed at zero by means of the magnet *m*. The needles are most sensitive when the oscillations occur slowly. The sensitiveness of the needles can be regulated by means of the magnet. In every case the instrument must be quite level, and for this purpose there is a small spirit-level in the base of the galvanometer.]

[Shunt.—As the galvanometer is very delicate, it is convenient to have a shunt to regulate to a certain extent the amount of electricity transmitted through the galvanometer. The shunt (Fig. 292) consists of a brass box containing coils of German silver wire, and is constructed on the same principle as resistance coils or the rheocord (p. 734). On the upper surface of the box, are several plates of brass separated from each other, like those of the rheocord, but which can be united by brass plugs. The two wires coming from the electrodes are connected with the two binding screws, and from the latter, two wires are led to the two outer binding screws of the galvanometer. By placing a plug between the brass plates attached to the two binding screws in the figure, the current is short-circuited. On removing both plugs, the whole of the current must pass through the galvanometer. If one plug be placed between the central disc of brass and the plate marked $\frac{1}{2}$ (the other being left out), then $\frac{1}{17}$ th of the current goes through the galvanometer and $\frac{16}{17}$ ths to the electrodes. If the plug be placed as shown in the figure opposite $\frac{1}{3}$, then $\frac{1}{10}$ th part of the current goes to the galvanometer, while $\frac{9}{10}$ ths are short-circuited. If the plug be placed opposite $\frac{1}{5}$, only $\frac{1}{10}$ th part goes through the galvanometer.]

Internal Polarisation of Moist Bodies.—Nerves and muscular fibres, the juicy parts of vegetables and animals, fibrin, and other similar bodies possessing a porous structure filled with fluid, exhibit the phenomena of polarisation when subjected to strong currents—a condition termed internal polarisation of moist bodies by du Bois-Reymond. It is assumed that the solid parts in the interior of these bodies, which are better conductors, produce electrolysis of the adjoining fluid, just like metals in contact with fluid. The ions produced by the decomposition of the internal fluids give rise to differences of potential, and thus cause internal polarisation (§ 333).

Cataphoric Action.—If the two electrodes from a galvanic battery be placed in the two compartments of a fluid, separated from each other by a porous septum, we observe that the fluid particles pass in the direction of the galvanic current, from the + to the - pole, so that after some time, the fluid in the one half of the vessel increases, while it diminishes in the other. The phenomenon of direct transference was called by du Bois-Reymond the *cataphoric action of the constant current*. The introduction of dissolved substances through the skin by means of a constant current depends upon this action (§ 290), and so does the so-called Porret's phenomenon in living muscle (§ 293, I., b).

External Secondary Resistance.—This condition also depends on cataphoric action. If each of the *copper* electrodes of a constant battery be placed in a vessel filled with a solution of cupric sulphate, and from each of which there projects a cushion saturated with this fluid, then, on placing a piece of muscle, cartilage, vegetable tissue, or even a prismatic strip of coagulated albumin, across these cushions, we observe that, very soon after the circuit is closed, there is a considerable variation of the current. If the direction of the current be reversed, it first becomes stronger, but afterwards diminishes. By constantly altering the direction of the current we cause the same changes in the intensity. If a prismatic strip of coagulated albumin is used for the experiment, we observe that simultaneously with the enfeeblement of the current, in the neighbourhood of the + pole, the albumin loses water and becomes more shrivelled, while at the - pole the albumin is swollen up and contains more water. If the direction of the current be altered, the phenomena are also changed. The shrivelling and removal of water in the albumin at the positive pole must be the cause of the resistance in the circuit, which explains the enfeeblement of the galvanic current. This phenomenon is called "external secondary resistance" (du Bois-Reymond).

329. Induction—Extra Current—Unipolar Induction Action—Magneto-Induction.

Induction of the Extra Current.—If a galvanic element is closed by means of a short arc of wire, at the moment the circuit is again opened or broken, a *slight* spark is observed. If, however, the circuit is closed by means of a very long wire rolled in a coil, then on breaking the circuit there is a *strong* spark. If the wires be connected with two electrodes, so that a person can hold one in each hand, so that the current at the moment it is opened must pass through the person's body, then there is a violent shock communicated to the hand. This phenomenon is due to a current induced in the long spiral of wire, which Faraday called the *extra current*. This is caused thus :—When the circuit is closed by means of the spiral wire, the galvanic current passing along it excites an electric current in the adjoining coils of the same spiral. At the moment of closing or making the circuit in the spiral, the induced current is in the opposite direction to the galvanic current in the circuit; hence, its strength is lessened, and it causes no shock. At

the moment of opening, however, the induced current has the same direction as the galvanic stream, and, hence, its action is strengthened.

Magnetisation of Iron.—If a *rod of soft iron* be placed in the cavity of a spiral of copper wire, then the soft iron remains magnetic as long as a galvanic current circulates in the spiral. If one end of the iron rod be directed towards the observer, the other away from him, and if, further, the positive current traverses the spiral in the same direction as the hands of a clock, then the end of the magnet directed towards the person is the negative pole of the magnet. The power of the magnet depends upon the number of spiral windings and on the thickness of the iron bar. As soon as the current is opened, the magnetism of the iron rod disappears.

Induced or Faradic Current.—If a very long insulated wire be coiled into the form of a spiral roll, which we may call the *secondary spiral*, and if a similar spiral, the *primary spiral*, be placed near the former, and the ends of the wire of the primary spiral be connected with the poles of a constant battery, every time the current in the primary circuit is made (closed), or broken (opened), a current takes place, or, as it is said, is *induced* in the secondary spiral. If the primary circuit be kept closed, and if the secondary spiral be brought nearer to or removed further from the primary spiral, a current is also induced in the secondary spiral (Faraday, 1832). The current in the secondary circuit is called the *induced* or *Faradic current*. When the primary circuit is *closed*, or when the two spirals are brought nearer to each other, the current in the secondary spiral has a direction *opposite* to that in the primary spiral, while the current produced by *opening* the primary circuit, or by removing the spirals further apart, has the *same* direction as the primary. During the time the primary circuit is closed, or when both spirals remain at the same distance from each other, there is no current in the secondary spiral.

Difference between the Opening and Closing Shocks.—The opening [break] and closing [make] shocks in the secondary spiral are distinguished from each other in the following respects (Fig. 293):—The amount of electricity is the same during the opening as during the closing shock, but during the *opening* shock, the electricity *rapidly* reaches its maximum of intensity and lasts but a short time, while during the *closing* shock, it *gradually* increases, but does not reach the same high maximum, and this occurs more slowly. [In Fig. 293, P_1 and S_0 are the abscissæ of the primary (inducing) and induced currents respectively. The vertical lines or *ordinates* represent the *intensity* of the current, while the length of the *abscissa* indicates its *duration*. The curve, 1, indicates the course of the primary current, and 2, that in the secondary spiral (induced) when the current is *closed*, while at 1, the primary current is suddenly opened, when it gives rise to the induced current, 4, in the secondary spiral.] The cause of this difference is the following:—When the primary circuit is *closed*, there is developed in it the *extra current*, which is *opposite* in direction to the primary current. Hence, it opposes considerable resistance to the complete development of the strength of the primary current, so that the current induced in the secondary spiral must also develop slowly. But when the primary spiral is *opened*, the extra current in the latter has the *same* direction as the primary current—there is no extra resistance. The rapid and intense action of the *opening* induction shock is of great physiological importance.

Opening Shock.—[On applying a *single* induction shock to a nerve or a muscle, the effect is *greater* with the *opening* shock. If the secondary spiral be separated from the primary, so that the induced currents are not sufficient to cause contraction of a muscle when applied to its motor nerve, then, on gradually approximating the secondary to the primary spiral, the *opening* shock will cause a contraction before the closing one does so.]

Helmholtz's Modification.—Under certain circumstances, it is desirable to

equalise the opening and closing shocks. This may be done by greatly weakening the extra current, which may be accomplished by making the primary spiral of only a few coils of wire. V. Helmholtz accomplishes the same result by introducing a secondary circuit into the primary current. By this arrangement, the current in the primary spiral never completely disappears, but, by alternately closing and opening this secondary circuit where the resistance is much less, it is alternately weakened and strengthened.

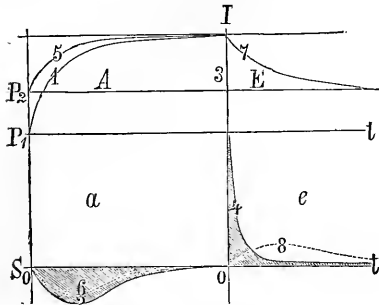

Fig. 293.

Scheme of the induced currents— P_1 , abscissa of the primary, S_0 , abscissa of the secondary current; A, beginning, and, E, end of the inducing current; 1, curve of the primary current weakened by the extra current; 3, where the primary current is broken or opened; 2 and 4, corresponding currents induced in the secondary spiral; P_2 , height, *i.e.*, the strength of the constant inducing current during Helmholtz's modification; 5 and 7, the curve of the inducing current when it is opened and closed during Helmholtz's modification; 6 and 8, the corresponding currents induced in the secondary circuit.

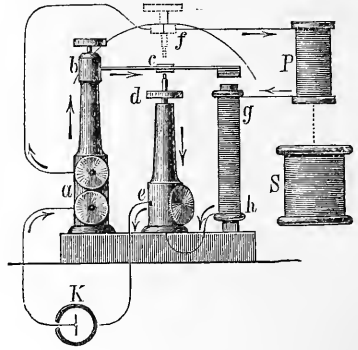

Fig. 294.

Helmholtz's modification of Neef's hammer. As long as c is not in contact with d , g h remains magnetic; thus c is attracted to d , and a secondary circuit, a, b, c, d, e , is formed; c then springs back again, and thus the process goes on. A new wire is introduced to connect a with f . K, battery.

[In Fig. 294, a wire is introduced between a and f , while the binding screw, f , is separated from the platinum contact, c , of Neef's hammer, but, at the same time, the screw, d , is raised so that it touches Neef's hammer. The current passes from the battery, K, through the pillar, a , to f in the direction of the arrow, through the primary spiral, P, to the coil of soft wire, g , and back to the battery, through h and e . But g is magnetised thereby, and when it is so, it attracts c and makes it touch the screw, d . Thus a secondary circuit, or short circuit, is formed through a, b, c, d, e , which weakens the current passing through the electro-magnet, g , so that the elastic metallic spring flies up again and the current through the primary spiral is long circuited, and thus the process is repeated. In Fig. 293 the lines 1 and 7 indicate the course of the current in the primary circuit at closing (a), and opening (e). It must be remembered that in this arrangement there is always a current passing through the primary spiral, P (Fig. 294). The dotted lines, 6 and 8 above and below S_0 , represent the course of the opening (a) and closing shocks (e) in the secondary spiral. Even with this arrangement, the opening is still

slightly stronger than the closing shock.] The two shocks, however, may be completely equalised by placing a resistance coil or rheostat in the short circuit which increases the resistance, and thus increases the current through the primary spiral when the short circuit is closed.

Unipolar Induction.—When there is a very rapid current in the primary spiral, not only is there a current induced in the secondary spiral when its free ends are closed, *e.g.*, by being connected with an animal tissue, but there is also a current when *one* wire is attached to a binding screw connected with one end of the wire of the secondary spiral (p. 725). A muscle of a frog's leg, when connected with this wire, contracts, and this is called a *unipolar induced contraction*. It usually occurs when the primary circuit is opened. The occurrence of these contractions is favoured when the other end of the spiral is placed in connection with the ground, and when the frog's muscle preparation is not completely insulated.

Magneto-Induction.—If a magnet be brought near to, or thrust into the interior of, a coil of wire, it excites a current, and also when a piece of soft iron is suddenly rendered magnetic or suddenly demagnetised. The direction of the current so induced in the spiral is exactly the same as that with faradic electricity, *i.e.*, the occurrence of the magnetism on approximating the spiral to a magnet, excites an induced current in a direction opposite to that supposed to circulate in the magnet. Conversely, the demagnetisation, or the removal of the spiral from the magnet, causes a current in the same direction.

330. Du Bois-Reymond's Inductorium—Magneto-Induction Apparatus.

Inductorium of du Bois-Reymond.—The induction-apparatus of du Bois-Reymond, which is used for physiological purposes, is a modification of the magneto-electro-motor apparatus of Wagner and Neef. A scheme of the apparatus is given in Fig. 295: D represents the *constant element*—*i.e.*, the galvanic battery. The wire from the positive pole, *a*, passes to a metallic column, S, which has a horizontal *vibrating spring*, F, attached to its upper end. To the outer end of the spring, a square piece of iron, *e*, is attached. The middle point of the upper surface of the spring, [covered with a little piece of platinum], is in contact with a movable screw, *b*. A moderately thick copper wire, *c*, passes from the screw, *b*, to the *primary spiral* or coil, *x, x*, which contains in its interior a number of pieces of soft iron wire, *i, i*, covered with an insulating varnish. The copper wire which surrounds the primary spiral is covered with silk. The wire, *d*, is continued from the primary spiral to a *horse-shoe* piece of soft iron, H, around which it is coiled spirally, and from thence it proceeds, at *f*, back to the negative pole of the battery, *g*.

When the current in this circuit—called the *primary circuit*—is closed, the following effects are produced:—The *horse-shoe*, H, becomes magnetic, in consequence of which it attracts the movable spring or Neef's hammer, *e*, whereby the contact of the spring, F, with the screw, *b*, is broken. Thus the current is broken, the horse-shoe is demagnetised, the spring, *e*, is liberated, and being elastic, it springs upwards again to its original position in contact with *b*, and thus the current is re-established. The new contact causes H to be re-magnetised, so that it must alternately rapidly attract and liberate the spring, *e*, whereby the primary current is rapidly made and broken between F and *b*.

A *secondary spiral* or coil (K, K) is placed in the same direction as the primary (*x, x*), but having no connection with it. It moves in grooves upon a long piece of wood (*p, p*). The secondary spiral consists of a hollow cylinder of wood covered with numerous coils of *thin* silk-covered wire. The secondary spiral moving in slots,

can be approximated to or even pushed entirely over the primary spiral, or can be removed from it to any distance desired.

[Fig. 296 shows the actual arrangement of du Bois-Reymond's electromotor. The primary coil (R') consists of about 150 coils of *thick* insulated copper wire,

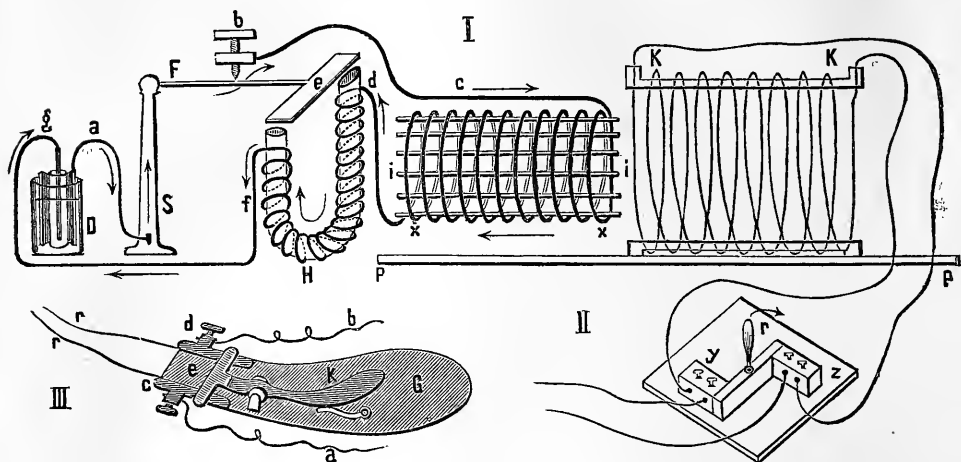

Fig. 295.

I, Scheme of du Bois-Reymond's sledge-induction machine. D, constant element; a , wire from + pole, (g) - pole; S, brass upright; F, elastic spring; b , binding screw; c , wire round primary spiral (x, x), containing (i, i) soft iron wire; K, K, secondary spiral, with board (p, p) on which it can be moved; H, soft iron magnetised by current (d, f) passing round it. II, key for secondary circuit, as shown it is short-circuited. III, electrodes (r, r), with a key (K) for breaking the circuit.

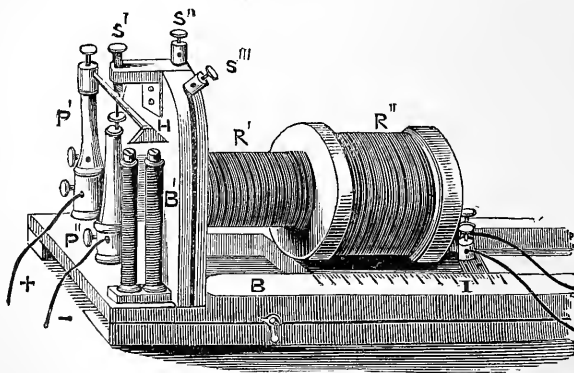

Fig. 296.

Induction apparatus of du Bois-Reymond— R' , primary, R'' , secondary spiral; B, board on which R'' moves; I, scale; + -, wires from battery; P', P'', pillars; H, Neef's hammer; B', electro-magnet; S', binding screw touching the steel spring (H); S'' and S''', binding screws to which to attach wires when Neef's hammer is not required (Elliott Brothers).

the wire being thick to offer slight resistance to the galvanic current. The secondary coil (R'') consists of 6000 turns of *thin* insulated copper wire arranged on a wooden bobbin; the whole spiral can be moved along the board (B), to which a millimetre scale (I) is attached, so that the distance of the secondary from the primary spiral may be ascertained. At the left end of the apparatus is Wagner's hammer as adapted by Neef, which is just an automatic arrangement for opening and breaking the primary circuit. When Neef's hammer is used, the wires from the battery are connected as in the figure, but when single shocks are required, the wires from the battery are connected with a key, and this again with the two terminals of the primary spiral, S' and S'' .]

According to the law of induction (p. 743), when the primary circuit is closed, a current is induced in the secondary circuit in a direction the *reverse* of that in the primary, while when it is opened, the induced current has the *same* direction. Further, according to the laws of magneto-induction, there is the magnetisation of the iron rods (i, i) within the primary spiral (x, x), that causes a *reverse* current in the secondary spiral (K, K), while the demagnetisation of the iron rods, on opening the primary circuit, causes an induced current in the *same* direction. Thus we explain the much more powerful action of the opening shock

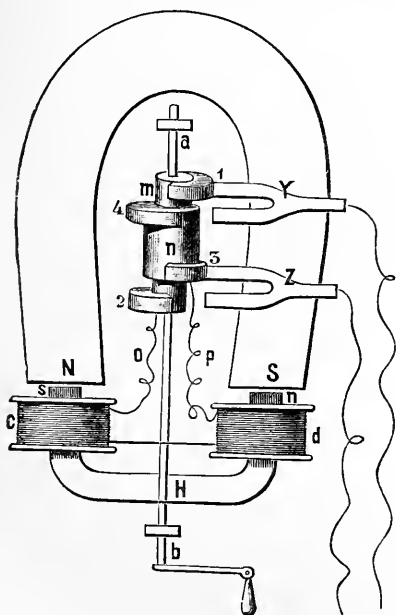

Fig. 297.

Magneto-induction Apparatus, with Stöhrer's Commutator.

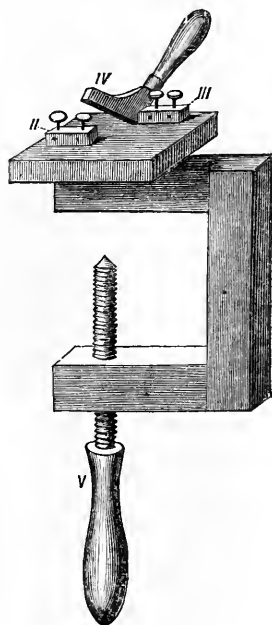

Fig. 298.

Du Bois-Reymond's Friction key (Elliott Brothers).

as compared with the closing shock. [The direction of the *inducing* current remains the *same*, while the *induced currents* are *constantly reversed*.]

The **magneto-induction** (R) apparatus of Pixii (1832), improved by Saxton, and still further improved by Stöhrer (Fig. 297), consists of a very powerful horse-shoe *steel magnet*. Opposite its two poles (N and S) is a horse-shoe-shaped piece of iron (H), which rotates on a horizontal axis (a, b). On the ends of the horse-shoe are fixed wooden bobbins (c, d), with an insulated wire coiled round

them. When the horse-shoe is at rest, as in the figure, it becomes magnetised by the steel magnet, while in the wires of both bobbins (*c* and *d*), an electric current is developed every time the horse-shoe is demagnetised, and again magnetised. When the bobbins rotate in front of the magnet, as each coil approaches one pole a current is induced, and similarly when it is carried past the pole of the magnet, so that four currents are induced in each coil by a single rotation. By means of Stöhrer's commutator (*m*, *n*) attached to the spindle (*a*, *b*), and the divided metal plates (*y*, *z*), which pass to the electrodes, the two currents induced in the bobbins are obtained in the same direction.]

Keys.—Keys, or arrangements for opening or breaking a circuit, are of great use. Fig. 296, II, shows a scheme of a **friction key** of du Bois-Reymond, introduced into the secondary circuit. It consists of two brass bars (*z* and *y*) fixed to a plate of ebonite, and as long as the key is down on the metal bridge (*y*, *r*, *z*) it is "*short-circuited*"—*i.e.*, the conduction is so good through the thick brass bars that none of the current goes through the wires leading from the left of the key. When the bridge (*r*) is lifted the current is opened. [The term accessory circuit is also used for short circuit.] [Fig. 298 shows the actual form of the key, *v* being a screw wherewith to clamp it to the table.] Similarly the key electrodes (III) may be used, the current being made as soon as the spring connecting-plate (*e*) is raised by pressing upon *k*. This instrument is opened by the hand; *a*, *b* are the wires from the battery or induction machine; *r*, *r*, those going to the tissue; *G*, the handle of the instrument.

[**Plug Key.**—Other forms of keys are in use—*e.g.*, Fig. 299, the plug key, the

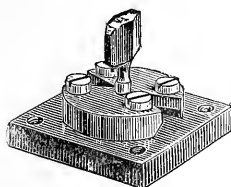

Fig. 299.
Plug Key.

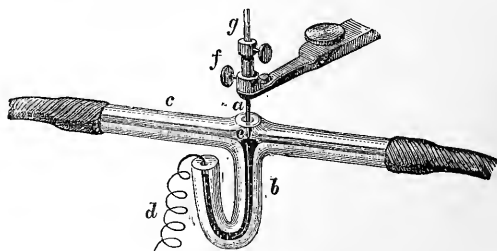

Fig. 300.

Capillary contact, as used by Kronecker and Stirling—*e*, Vibrating platinum style adjustable by *f* and *g* and dipping into mercury at *a*; *b*, bent tube filled with mercury, into which dips a wire (*d*); *a*, opening in cross tube (*c*).

two brass plates to which the wires are attached being fixed on a plate of ebonite. The brass plug is used to connect the two brass plates. All these are *dry* contacts, but sometimes a *fluid* contact is used as in the **mercury key**, which merely consists of a block of wood with a cup of mercury in its centre. The ends of the wires from the battery dip into the mercury; when both wires dip in the mercury the circuit is made, and when one is out it is broken.]

[**Capillary Contact Key.**—Where an ordinary mercury key is used to open and close the primary circuit, the layer of oxide formed on the surface by the opening spark disturbs the conduction after a short time; hence, it is advisable to wash the surface of the mercury with a dilute solution of alcohol and water (W. Stirling). A handy form of "capillary contact" is shown in Fig. 300, such as was used by Kronecker and Stirling in their experiments on the heart (p. 107). "A glass T-tube is provided at the crossing point with a small opening (*a*). The vertical tube (*b*) is bent in the form of a U, and filled so full with mercury that the convex surface of the latter projects within the lumen of the transverse tube (*c*). One

end of *c* is connected with a Mariotte's flask containing diluted alcohol, and the supply of the latter can be regulated by means of a stop-cock. The fluid flows over the apex of the mercury, and keeps it clean. The vibrating platinum style (*e*) is attached to the end of a rod, which in turn is connected with the positive pole of the battery, while the platinum wire (*d*) is connected with the negative pole of the battery."]

331. Electrical Currents in Passive Muscle and Nerve.

Methods.—In order to investigate the laws of the muscle-current, we must use a muscle composed of parallel fibres, and with a simple arrangement of its fibres in the form of a prism or cylinder (Fig. 301, I and II). The sartorius muscle of the frog supplies these conditions. In such a muscle we distinguish its *surface*, or the *natural longitudinal section*, its *tendinous ends*, or the *natural transverse section*; further, when the latter is divided transversely to the long axis, the *artificial transverse section* (Fig. 301, I, *c, d*); lastly, the term *equator* (*a, b-m, n*) is applied to a line so drawn as exactly to divide the length of the muscle into halves. As the currents are very feeble, it is necessary to use a galvanometer with a periodic damped magnet (Figs. 284, I, and 290), or a tangent mirror-boussole, such as is used for thermo-electric purposes (Fig. 168). The wires leading from the tissue are connected with non-polarisable electrodes (Fig. 284, P, P).

The **Capillary-electrometer** of Lippmann may be used for detecting the current. [This instrument depends on the fact that a globule of mercury in dilute sulphuric acid, when traversed by an electrical current, shows the meniscus of the mercury passing towards the negative pole. The movement of the mercury may be observed by means of a microscope provided with an eye-piece micrometer. A very simple and convenient modification of this instrument for studying the muscle-current has recently been invented by M'Kendrick.]

Compensation.—The *strength* of the current in animal tissues is best measured by the compensation method of Poggendorf and du Bois-Reymond. A current of known strength, or which can be accurately graduated, is passed in an opposite direction through the same galvanometer or boussole, until the current from the animal tissue is just neutralised or compensated. [When this occurs, the needle deflected by the tissue-current returns to zero. The principle is exactly the same as that of weighing a body in terms of some standard weights placed in the opposite scale-pan of the balance].

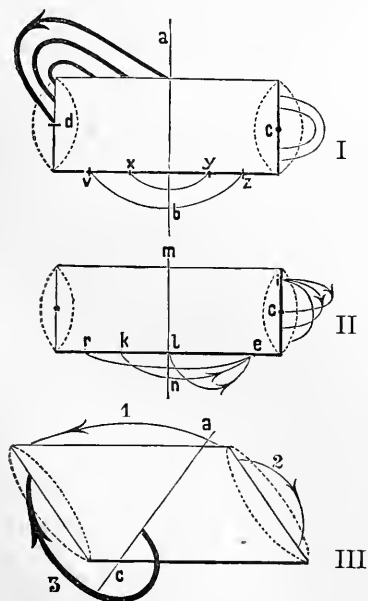

Fig. 301.

Scheme of the muscle-current.

1. According to Hermann, perfectly fresh, uninjured muscles yield no current, and the same is true of dead muscle.

2. *Strong* electrical currents are observed when the *transverse section* of a muscle is placed on one of the cushions of the non-polarisable

electrodes (Fig. 284, I, M), while the *surface* is in connection with the other (Nobili, Matteucci, du Bois-Reymond). The *direction* of the current is from the (positive) longitudinal section to the (negative) transverse section in the conducting wires (*i.e.*, within the muscle itself from the transverse to the longitudinal section—Figs. 284, I, and 301, I). This current is stronger the nearer one electrode is to the equator, and the other to the centre of the transverse section; while the strength diminishes the nearer the one electrode is to the end of the surface, and the other to the margin of the transverse section.

Smooth muscles also yield similar currents between their transverse and longitudinal surfaces (§ 334, II).

3. *Weak* electrical currents are obtained when—(a) two points at unequal distances from the equator are connected; the current then passes from the point nearer the equator (+) to the point lying further from it (—), but, of course, this direction is reversed within the muscle itself (Fig. 301, II, *k, e*, and *l, e*). (b) Similarly, weak currents are obtained by connecting points of the transverse section at unequal distances from the centre, in which case the current outside the muscle passes from the point lying nearer the edge of the muscle to that nearer the centre of the transverse section (Fig. 303, II, *i, c*).

4. When two points on the surface are equidistant from the equator (Fig. 301, I, *x, y, v, z*—II, *r, e*), or two equidistant from the centre of the transverse section (II, *c*) are connected, no current is obtained.

5. The passive **nerve** behaves like muscle, as far as 2, 3, and 4 are concerned.

The electro-motive force of the strongest nerve-current, according to du Bois-Reymond, is 0.02 of a Daniell. Heating a nerve to 15°–25° C. increases the nerve-current, while high temperatures diminish it (Steiner).

6. If the transverse section of a muscle be *oblique* (Fig. 301, III), so that the muscle forms a *rhomb*, the conditions obtaining under III are disturbed. The point lying nearer to the *obtuse* angle of the transverse section or surface is positive to the one lying near to the acute angle. The equator is oblique (*a, c*). These currents are called "*deviation currents*" by du Bois-Reymond, and their course is indicated by the lines 1, 2, and 3.

Strength of Electro-motive Force.—The electro-motive force of a *strong muscle-current* (frog) is equal to 0.05–0.08 of a Daniell's element; while the strongest deviation current may be 0.1 Daniell. The muscles of a curarised animal at first yield stronger currents; *fatigue* of the muscle diminishes the strength of the current (Roerber), while it is completely abolished when the muscle dies. *Heating* a muscle increases the current; but above 40°C. it is diminished (Steiner). *Cooling* diminishes the electro-motive force. The warmed

living muscular and nervous substance (Hermann, Worm Müller, Grützner) is positive to the cooler portions; while, if the *dead* tissues be heated, they behave practically as indifferent bodies as regards the tissues that are not heated.

Rheoscopic Limb.—The existence of a muscle-current may be proved without the aid of a galvanometer: 1. By means of a sensitive nerve-muscle preparation of a frog, or the so-called "*physiological rheoscope*." Place a moist conductor on the transverse and longitudinal surface of the gastrocnemius of a frog. On placing the sciatic nerve of a nerve-muscle preparation of a frog on this conductor, so as to bridge over or connect these two surfaces, contraction of the muscle connected with the nerve occurs at once; and the same occurs when the nerve is again removed.

[Use a nerve-muscle preparation, or, as it is called, a physiological limb. Hold the preparation by the femur, and allow its own nerve to fall upon the gastrocnemius, and the muscle will contract, but it is better to allow the nerve to fall suddenly upon the cross section of the muscle. The nerve then completes the circuit between the longitudinal and transverse section of the muscle, so that it is stimulated by the current from the latter, the nerve is stimulated, and through it the muscle. That it is so, is proved by tying a thread round the nerve near the muscle, when the latter no longer contracts.]

Contraction without Metals.—Make a transverse section of a gastrocnemius muscle of a frog's nerve-muscle preparation, and allow the sciatic nerve to fall upon this transverse section, when the limb contracts, as the muscle-current from the longitudinal to the transverse surface now traverses the nerve (Galvani, Al. v. Humboldt).

2. **Self-Stimulation of the Muscle.**—We may use the *muscle-current* of an isolated muscle to stimulate the latter directly and cause it to contract. If the transverse and longitudinal surfaces of a curarised frog's nerve-muscle preparation be placed on non-polarisable electrodes, and the circuit be closed by dipping the wires coming from the electrodes in mercury, then the muscle contracts. Similarly, a *nerve* may be stimulated with its own current (du Bois-Reymond and others). If the lower end of a muscle with its transverse section be dipped into normal saline solution (0.6 per cent. NaCl), which is quite an indifferent fluid, this fluid forms an accessory circuit between the transverse and adjoining longitudinal surface of the muscle, so that the muscle contracts. Other indifferent fluids used in the same way produce a similar result (E. Hering).

3. **Electrolysis.**—If the muscle-current be conducted through *starch mixed with potassic iodide*, then the iodine is deposited at the + pole, where it makes the starch blue.

Frog Current.—It is asserted that the total current in the body is the sum of the electrical currents of the several muscles and nerves which, in a frog deprived

of its skin, passes from the tip of the toes toward the trunk, and in the trunk from the anus to the head. This is the "*corrente propria della rana*" of Leopoldo Nobili (1827), or the "*frog current*" of du Bois-Reymond. In mammals, the corresponding current passes in the opposite direction.

After death, the currents disappear sooner than the excitability (Valentin); they remain longer in the muscle than the nerves, and in the latter, they disappear sooner in the central portions. If the nerve-current after a time becomes feeble, it may be strengthened by making a new transverse section of the nerve. A motor nerve completely paralysed by *curara* gives a current (Funke), and so does a nerve beginning to undergo degeneration, even two weeks after it has lost its excitability. Muscles in a state of *rigor mortis* give currents in the opposite direction, owing to inequalities in the decomposition which takes place. The nerve-current is reversed by the action of boiling water or drying.

Currents from Skin and Mucous Membranes.—In the *skin of the frog*, the outer surface is +, the inner is - (du Bois-Reymond, Budge), and the same is true of the mucous membrane of the intestinal tract (Rosenthal), the cornea (Grünhagen), as well as the *non-glandular* skin of fishes (Hermann) and molluscs (Oehler).

332. Currents of Stimulated Muscle and Nerve.

1. **Negative Variation of the Muscle-Current.**—If a muscle which yields a strong electrical current, be thrown into a state of tetanic contraction by stimulating its motor nerve, then, when the muscle contracts, there is a *diminution* of the muscle-current, and occasionally, the needle of the galvanometer may swing almost to zero. This is the *negative variation of the muscle-current* (du Bois-Reymond). It is larger, the greater the primary deflection of the galvanometer needle and the more energetic the contraction.

After tetanus, the muscle-current is weaker than it was before. If the muscle was so placed upon the electrodes that the current was "feeble," equally during tetanus there is a diminution of this current. In the inactive arrangement, the contraction of the muscle has no effect on the needle. If the muscle be prevented from shortening, as by keeping it tense, the negative variation still takes place.

2. **Current during Tetanus.**—An *excised frog's* muscle *tetanised* through its *nerve* shows electro-motive force—the so-called "*action current*." In a tetanised frog's gastrocnemius, there is a *descending* current. In completely uninjured human muscles, however, thrown into tetanus by acting on their nerves, there is no such current (L. Hermann); similarly, in *quite uninjured* frog's muscles, as well as when these muscles are *directly* and *completely tetanised*, there is no current.

3. **Current during the Contraction Wave.**—If one end of a muscle be directly excited with a momentary stimulus, so that the *contraction wave* (§ 299) rapidly passes along the whole length of the muscular

fibres, then each part of the muscle successively and immediately before it contracts, shows the negative variation. Thus the "contraction wave" is preceded by a "negative wave" of the muscle-current, the latter occurring during the *latent period*. Both waves have the same velocity, about 3 metres per second. The negative wave, which first increases and then diminishes, lasts at each point only 0.003 second (Bernstein).

4. **During a Single Contraction.**—A *single* contraction also shows a muscle-current. The best object to use for this purpose is a *contracting heart*, which is placed upon the non-polarisable electrodes connected with a sensitive galvanometer. Each beat of the heart causes a deflection of the needle, which occurs *before* the contraction of the cardiac muscle (Kölliker and H. Müller—compare p. 109). The electrical disturbance in the muscle causing the negative variation always precedes the actual contraction (v. Helmholtz, 1854). When the completely uninjured frog's gastrocnemius contracts by stimulating the nerve, there is at first a descending and then an ascending current (Sig. Mayer).

Secondary Contraction.—A *nerve-muscle* preparation may be used to demonstrate the electrical changes that occur during a *single* contraction. If the sciatic nerve, A, of such a preparation be placed upon another muscle, B, as in Fig. 302, then every time the latter, B, contracts, the frog's muscle, A, connected with the nerve also contracts.

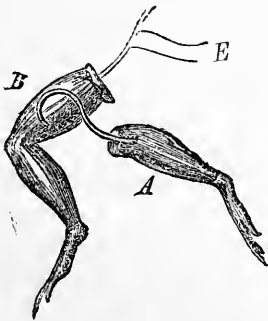

Fig. 302.

Secondary contraction—The sciatic nerve of A lies on B; E, electrodes applied to the sciatic nerve of B.

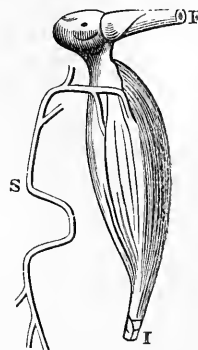

Fig. 303.

Nerve-muscle preparation of a frog—F, femur; S, sciatic nerve; I, tendo achilles.

If the nerve of a frog's nerve-muscle preparation be placed on a contracting mammalian heart, then a contraction of the muscle occurs with every beat of the heart (Matteucci, 1842). The diaphragm, even after section of the phrenic nerve, especially the left, also contracts

during the heart-beat (Schiff). This is the "*secondary contraction*" of Galvani.

Secondary Tetanus.—Similarly, if a nerve of a nerve-muscle preparation be placed on a muscle which is tetanised, then the former also contracts, showing "*secondary tetanus*" (du Bois-Reymond). The latter experiment is regarded as a proof that, during the process of negative variation in the muscle, many successive variations of the current must take place, as only rapid variations of this kind can produce tetanus by acting on a nerve, *continuous* variations being unable to do so.

Usually there is no secondary tetanus in a frog's nerve-muscle preparation when it is laid upon a muscle which is tetanised voluntarily, or by chemical stimuli, or by poisoning with strychnin (Hering and Friedreich, Kühne); still, Lovèn has observed secondary strychnin tetanus, composed of 6-9 shocks per second. Observations with a sensitive galvanometer or Lippmann's capillary electrometer, show that the spasms of strychnin poisoning, as well as a voluntary contraction, are discontinuous processes (Lovèn—p. 653).

[**Nerve-Muscle Preparation.**—This term has been used on several occasions. It is simply the sciatic nerve with the gastrocnemius of the frog attached to it (Fig. 303). The sciatic nerve is dissected out entire from the vertebral column to the knee; the muscles of the thigh separated from the femur, and the latter divided about its middle, so that the preparation can be fixed in a clamp by the remaining portion of the femur; while the tendon of the gastrocnemius is divided near to the foot. If a straw flag is to be attached to the foot, do not divide the tendo achilles.]

5. Negative Variation in Nerve.—If a *nerve* be placed with its transverse section on one non-polarisable electrode, and its longitudinal surface on the other, and if it be stimulated electrically, chemically, or mechanically, the nerve-current is also diminished (du Bois-Reymond). This *negative variation* can be propagated towards *both* ends of a nerve, and is composed of very rapid, successive, periodic, interruptions of the original current, just as in a contracted muscle (Bernstein); while Hering succeeded in obtaining from a nerve, as from a muscle, a secondary contraction or secondary tetanus. The amount of the negative variation depends upon the extent of the primary deflection, also upon the degree of nervous excitability, and on the strength of the stimulus employed. The negative variation occurs with *tetanic* as well as by stimulation with *single* shocks. The negative variation is not observed in completely uninjured nerves.

Hering found that, the negative variation of the nerve-current caused by tetanic stimulation is followed by a *positive* variation, which occurs immediately after the former. It increases to a certain degree with the duration of the stimulation, as well as with the strength of the stimulus.

Negative Variation of the Spinal Cord.—This is the same as in nerves generally. If a current be conducted from the transverse and longitudinal surfaces of the upper part of the medulla oblongata, we observe *spontaneous* intermittent *negative variations*, perhaps due to the intermittent excitement of the nerve centres, more especially of the respiratory centre. Similar variations are obtained reflexly by single stimuli applied to the sciatic nerve, while strong stimulation by common salt or induction shocks inhibits them.

Velocity.—The process of negative variation is propagated at a measurable velocity along the nerve, most rapidly at 15–25°C. (Steiner), and at the same rate as the velocity of the nervous impulse itself, about 27–28 metres per second. The duration of a single variation (of which the process of negative variation is composed), is only 0·0005–0·0008 second, while the wave-length in the nerve is calculated by Bernstein at 18 mm.

Differential Rheotom.—J. Bernstein estimated the velocity of the negative variation in a nerve by means of a differential rheotom, thus:—A long stretch of a nerve is so arranged, that at *one* end of it, its transverse and longitudinal surfaces are connected with a galvanometer, while at the *other* end, are placed the electrodes of an induction machine. A disc, rapidly rotating on its vertical axis, has an arrangement at one point of its circumference, by means of which the current of the primary circuit is rapidly opened and closed during each revolution. This causes, with each rotation of the disc, an opening and a closing shock to be applied to the end of the nerve. At the diametrically opposite part of the circumference, is an arrangement by which the galvanometer circuit is closed and opened during each revolution. Thus, the stimulation and the closing of the galvanometer circuit occur at the same moment. On rapidly rotating the disc, the galvanometer indicates a *strong* nerve-current. At the moment of stimulation, the negative variation has not yet reached the other end of the nerve. If, however, the arrangement which closes the galvanometer circuit be so displaced along the circumference, that the galvanometer circuit is closed somewhat *later* than the nerve is stimulated, then the current is *weakened* by the negative variation. When we know the velocity of rotation of the disc, it is easy to calculate the rate at which the impulse causing the negative variation passes along a given distance of nerve.

The negative variation is absent in degenerated nerves, as soon as they lose their excitability.

Eye Currents.—If a freshly excised eyeball be placed on the non-polarisable electrodes connected with a galvanometer, and if light fall upon the eye, then the normal eye current from the cornea (+) to the transverse section of the optic nerve (–) is at first increased. Yellow light is most powerful, and less so the other colours (Holmgren, M'Kendrick, and Dewar). The inner surface of the *passive* retina is positive to the posterior. When the retina is illuminated, there is a double variation, a negative variation with a preliminary positive increase; while, when the light ceases, there is a simple positive variation. Retinæ, in which the visual purple has disappeared, owing to the action of light, show no variations (Kühne and Steiner).

333. Currents in Nerve and Muscle during Electrotonus.

1. **Positive Phase of Electrotonus.**—If a nerve be so arranged upon the electrodes (Fig. 304, I), that its transverse section lies on one, and its longitudinal on the other electrode, then the galvanometer indicates

a strong current. If now a *constant galvanic current* be transmitted through the end of the nerve projecting beyond the electrodes (the so-called "*polarising*" end of the nerve), and, if the direction of this current *coincides* with that in the nerve, then the magnetic needle gives a greater deflection, indicating an *increase* of the nerve-current—"the *positive phase of electrotonus*." The increase is greater, the longer the stretch of nerve traversed by the current, the stronger the galvanic current, and the less the distance between the part of the nerve traversed by the constant current and that on the electrodes.

2. **Negative Phase of Electrotonus.**—If in the same length of nerve, the constant current passes in the *opposite* direction to the nerve-current (Fig. 304, II), there is a diminution of the electro-motive force of the latter—"negative phase of electrotonus."

3. **Equator.**—If two points of the nerve equidistant from the equator be placed on the electrodes (III), there is no deflection of the galvanometer needle (p. 750, 4). If a constant current be passed through one free projecting end of the nerve, then the galvanometer indicates an electro-motive effect in the same direction as the constant current.

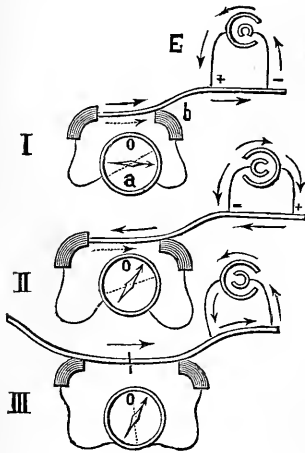

Fig. 304.

Nerve-current in electrotonus —
a, galvanometer; *b*, electrodes;
E, constant current.

Electrotonus. — These experiments show that a constant current causes a change of the electro-motive force of the part of the nerve directly traversed by the constant current, and also in the part of the nerve outside the electrodes. This condition is called *electrotonus* (du Bois-Reymond, 1843).

The electrotonic current is strongest not far from the electrodes, and it may be twenty-five times as strong as the nerve-current of rest (§ 331, 5); it is greater on the anode than on the cathode side; it undergoes a negative variation like the resting nerve-current during tetanus; it occurs at once on closing the constant current, although it diminishes uninterruptedly at the cathode (du Bois-Reymond). These phenomena take place only as long as the nerve is excitable. If the nerve be ligatured in the projecting part in the galvanometer circuit, the phenomena cease in the ligatured part. The negative variation (§ 332) occurs more rapidly than the electrotonic increase of the current, so that the former is over before the electro-motive increase occurs. The velocity of the electrotonic change in the current is less than the rapidity of propagation of the excitement in the nerves, being only 8-10 metres per second (Tschirjew, Bernstein).

“*The secondary contraction from a nerve*” depends upon the electrotonic state. If the sciatic nerve of a frog’s nerve-muscle preparation be placed on an excised nerve, and if a constant current be passed through the free end of the latter—non-electrical stimuli being inactive—the muscles contract. This occurs because the electrotonising current in the excised nerve stimulates the nerve lying on it. By rapidly closing and opening the current, we obtain “*secondary tetanus from a nerve.*”

Paradoxical Contraction.—Exactly the same occurs, when the current is applied to one of the two branches into which the sciatic nerve (cut through above) of the frog divides, *i.e.*, the muscles attached to both branches of the nerve contract.

Polarising After-Currents.—When the constant current is opened, there are *after-currents* depending upon internal polarisation (§ 328). In *living* nerves, muscle, and electrical organs this internal polarisation current, when a strong primary current of very short duration is used, is always *positive*—*i.e.*, has the same direction as the primary current. Prolonged duration of the primary current ultimately causes negative polarisation. Between these two is a stage when there is no polarisation. Positive polarisation is especially strong in nerves when the primary current has the direction of the impulse in the nerve; in muscle, when the primary current is directed from the point of entrance of the nerve into the muscle to the end of the muscle (§ 334, II).

4. **Muscle-Current during Electrotonus.**—The constant current also produces an electrotonic condition in *muscle*; a constant current in the same direction increases the muscle-current, while one in an opposite direction weakens it, but the action is relatively feeble.

334. Theories of Muscle and Nerve Currents.

I. Molecular Theory.—To explain the currents in muscle and nerve, du Bois-Reymond proposed the so-called molecular theory. According to this theory, a nerve- or muscle-fibre is composed of a series of small electro-motive molecules arranged one behind the other, and surrounded by a conducting, indifferent fluid. The molecules are supposed to have a positive equatorial zone directed towards the surface, and two negative polar surfaces directed towards the transverse section. Every fresh transverse section exposes new negative surfaces, and every artificial longitudinal section new positive areas.

This scheme explains the *strong* currents, for when the + longitudinal surface is connected with the - transverse surface, a current is obtained from the former to the latter; but it does not explain the *feeble* currents. To explain their occurrence we must assume that, on the one hand, the electro-motive force of the molecules is weakened with varying rapidity at unequal distances from the equator; on the other, at unequal distances from the transverse section. Then, of course, differences of electrical tension obtain between the stronger and the feebler molecules.

Parelectronomy.—But the *natural* transverse section of a muscle, *i.e.*, the end of the tendon, is not negative, but more or less positive electrically. To explain this condition, du Bois-Reymond assumes that on the end of the tendon there is a layer of electro-positive muscle-substance. He supposes that each of the peripolar elements of muscle consists of two bipolar elements, and that a layer of this *half* element lies at the end of the tendon, so that its positive side is turned toward the free surface of the tendon. This layer he calls the “*parelectronic layer.*” It is never completely absent. Sometimes it is so marked, as to make the end of the tendon + in relation to the surface. Cauterisation destroys it.

The negative variation is explained by supposing that, during the action of a muscle and nerve, the electro-motive force of all the molecules is diminished. During partial contraction of a muscle, the contracted part assumes more the characters of an indifferent conductor, which now becomes connected with the negative zone of the passive contents of the muscular fibres.

The electrotonic currents beyond the electrodes in nerves must be explained. To explain the electrotonic condition, it is assumed that the bipolar molecules are capable of rotation. The polarising current acts upon the direction of the molecules, so that they turn their negative surfaces towards the anode, and their positive surfaces to the cathode, whereby the molecules of the intrapolar region have the arrangement of a Volta's pile. In the part of the nerve outside the electrodes, the further removed it is, the less precisely are the molecules arranged. Hence, the swing of the needle is less, the further the extrapolar portion is from the electrodes.

II. Difference Theory.—The difference theory, proposed by L. Hermann, explains all the phenomena of the muscle and nerve currents thus:—The dying or active muscle is negative to the normal passive contents of the muscle or nerve, which are positively electrical.

Streamless Fresh Muscles.—It seems that passive, uninjured, and absolutely fresh muscles are completely devoid of a current, *e.g.*, the heart (Engelmann), also the musculature of fishes while still covered by the skin.

As the skin of the frog has currents peculiar to itself, it is possible with certain precautions, after destroying the skin with alkalis, to show the streamless character of frogs' muscles. L. Hermann also finds that the muscle-current is always developed after a time, which is very short, when a new transverse section is made.

Demarcation Current.—Every *injury* of a muscle or nerve causes at the point of injury (*demarcation surface*), a dying substance which behaves negatively to the positive intact substance. The current thus produced is called by Hermann the "*demarcation current*." If individual parts of a muscle be moistened with potash salts or muscle-juice, they become negatively electrical; if these substances be removed, these parts cease to be negative (Biedermann).

It appears that all living protoplasmic substance has a special property, whereby injury of a part of it makes it, *when dying, negative*, while the intact parts remain positively electrical. Thus, all transverse sections of living parts of plants are negative to their surface (Buff); and the same occurs in animal parts, *e.g.*, glands and bones.

Engelmann made the remarkable observation that, the heart and smooth muscle again lose the negative condition of their transverse section, when the muscle cells are completely dead, as far as the cement-substance of the nearest cells; in nerves, when the divided portion dies, as far as the first node of Ranvier. When all these organs are again completely streamless, then the absolutely dead substance behaves essentially as an indifferent moist conductor. Muscles divided subcutaneously and healed, do not exhibit a negative reaction of the surface of their section.

All these considerations go to show that the pre-existence of a current in living, uninjured tissues is very doubtful, and, perhaps, can no longer be maintained.

Action Currents.—The term "action current" is applied by L. Hermann to the currents obtained during the *activity of a muscle*. When a single stimulation wave (contraction) passes along muscular fibres, which are connected at two points with

a galvanometer, then that point through which the wave is just passing is negative to the other. Occasionally, in excised muscles, local contractions occur, and these points are negative to the other passive parts of the muscle (Biedermann). In order, therefore, to explain the currents obtained from a frog's leg during tetanus, we must assume that the end of the fibre which is negative participates less in the excitement than the middle of the fibre. But this is the case only in dying or fatigued muscles (p. 752, 2).

According to § 336, D, the direct application of a constant current to a muscle causes contraction first at the cathode, when the current is closed, and when it is opened, at the anode. This is explained by assuming that, during the closing contraction, the muscle is negative at the cathode, while with the opening contraction, the negative condition is at the anode.

If a muscle be thrown into contraction by stimulating its nerve, then the wave of excitement travels from the entrance of the nerve to both ends of the muscle, which also behave negatively to the passive parts of the muscle. According to the point at which the nerve enters the muscle, the ascending or descending wave of excitement will reach the end (origin or insertion) of the muscle sooner than the other. On placing such a muscle in the galvanometer circuit, then at first that end of the muscle will be negative which lies nearest to the point of entrance of the nerve (*e.g.*, the upper end of the gastrocnemius), and afterwards the lower end. Thus there appears rapidly after each other, at first a descending and then an ascending current in the galvanometer circuit, (of course reversed within the muscle itself)—(Sig. Mayer)—(p. 753, 4).

The same occurs in the muscles of the human fore-arm. When these were caused to contract through their *nerves*, at first the point of entrance of the nerve (10 c.m. above the elbow joint) was negative, and then followed the ends of the muscles when the contraction wave, with a velocity of 10-13 metres per second, reached them (L. Hermann)—(§ 399, 1).

If a completely uninjured, streamless muscle be made to contract *directly and in toto*, then neither during a single contraction nor in tetanus is there a current, because the whole of the muscle passes *at the same moment* into a condition of contraction.

Nerve and Secretion Currents.—Hermann also supposes that, the contents of dying or active nerves behave negatively to the passive normal portions. He also observed a current in the skin of the frog coincident with the formation of an alkaline secretion from the cutaneous glands. The direction of the current in the skin is from without inwards; so that he is inclined to regard the pre-existing skin current as a secretion current. The ascending current, observed in the limbs of a man, when the fingers of both hands are placed in the electrodes and the muscles of *one* limb contracted, he is also inclined to regard as a secretion current in the skin. Experiments on a cat, with its hind limbs in connection with a galvanometer, show that stimulation of *one* sciatic nerve, in addition to causing a secretion of sweat, causes an ascending "secretion current" (L. Hermann, Luchsinger).

According to L. Hermann, the four following considerations are sufficient to explain the occurrence of the galvanic phenomena in living tissues:—1. Protoplasm, by undergoing partial *death* in its continuity, whether by injury or by (horny or mucous) metamorphosis, becomes negative towards the uninjured part. 2. Protoplasm, by being partially *excited* in its continuity, becomes negative to the uninjured part. 3. Protoplasm, when partially *heated* in its continuity, becomes positive, and by cooling negative, to the unchanged part. All these results follow the ordinary law of tension or potential. 4. Protoplasm is strongly *polarisable* on its surface (muscle, nerve), the polarisation constants diminishing with excitement and in the process of dying.

Imbibition Currents.—When water flows through capillary spaces, this is

accompanied by an electrical movement in the same direction (Quincke, Zöllner). Similarly, the forward movement of water in the capillary interspaces of non-living parts (pores of a porcelain plate) is also connected with electrical movements, which have the same direction as the current of water. The same effect occurs in the movement of water, which results in that condition known as *imbibition* of a body. We must remember that at the demarcation surface of an injured nerve or muscle imbibition takes place; that also at the contracted parts of a muscle imbibition of fluid occurs (§ 297, II.); and that during secretion, there is a movement of the fluid particles.

In **Plants**, electrical phenomena have been observed during the *passive* bending of vegetable parts (leaves or stalks), as well as during the *active* movements which are associated with the bending of certain parts, *e.g.*, as in the mimosa or dionæa (p. 384)—(Burdon-Sanderson). These phenomena are perhaps explicable by the movement of water which must take place in the interior of the vegetable parts (A. G. Kunkel). The root cap of a sprouting plant is negative to the seed coverings (Hermann); the cotyledons positive to the other parts of the seedling (Müller-Hettlingen).

335. Alteration of the Excitability during Electrotonus.

Cause of Electrotonus.—If a certain stretch of a living nerve be traversed by a *constant* electrical (“*polarising*”) current, it passes into a *condition of altered excitability* (Ritter, 1802, Nobili, Valentin, Eckhard, Pflüger), which du Bois-Reymond called the electrotonic condition, or simply *electrotonus*. This condition of altered excitability extends not only over the part actually traversed by the current, *intrapolar portion*, but it is communicated to the entire nerve. Pflüger (1859) discovered the following laws of electrotonus:—

At the *positive* pole (*anode*—Fig. 305, *A*) the excitability is *diminished*—this is the region of *anelectrotonus*; at the *negative* pole (*cathode*—*K*) it is *increased*—this is the region of *cathelectrotonus*. The changes of excitability are most marked in the region of the poles themselves.

Indifferent Point.—In the *intrapolar region*, a point must exist where the anelectrotonic and cathelectrotonic regions meet, where therefore the excitability is unchanged; this is called the *indifferent or neutral point*. This point lies nearer the anode (*i*) with a weak current, but with a strong current nearer the cathode (*i_∞*); hence, in the first case, almost the whole intrapolar portion is more excitable; in the latter, less excitable. [Expressed otherwise, a weak current increases the area over which the negative pole prevails, while the reverse is the case with a strong current.] Very strong currents greatly diminish the conductivity at the anode, and indeed may make the nerve completely incapable of conduction at this part.

Extrapolar region.—The extrapolar area, or that lying outside the electrodes, is greater the stronger the current. Further, with the

weakest currents, the extrapolar anelectrotonic area is greater than the extrapolar cathelectrotonic. With strong currents this relation is reversed.

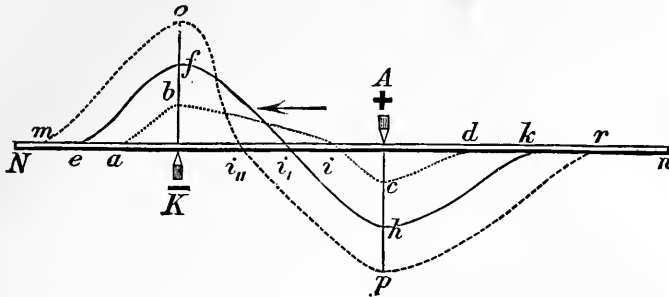

Fig. 305.

Scheme of the electrotonic excitability.

Fig. 305 shows the excitability of a nerve (N, n) traversed by a constant current in the direction of the arrow. The curve shows the degree of increased excitability in the neighbourhood of the cathode (K) as an elevation above the nerve, diminution at the anode (A) as a depression. The curve m, o, i, p, r , shows the degree of excitability with a strong current; e, f, i, h, k , with a medium current; lastly, a, b, i, c, d , with a weak current.

The electrotonic effect increases with the length of the nerve traversed by the current. The changes of the excitability in electrotonus occur instantly when the circuit is closed, while anelectrotonus develops and extends more slowly.

When the polarising current is opened, at first there is a *reversal* of the relations of the excitability, and then there follows a transition to the normal condition of excitability of the passive nerve (Pflüger). At the very first moment of closing, Wundt observed that the excitability of the whole nerve was increased.

I. Proof of Electrotonus in Motor-Nerves.—To test the laws of electrotonus, take a frog's nerve-muscle preparation (Fig. 303). A constant current (p. 733), is applied to a limited part of the nerve by means of non-polarisable electrodes. A stimulus, electrical, chemical (saturated solution of common salt), or mechanical is applied either in the region of the anode or cathode; and we observe whether the contraction which results is greater when the polarising current is opened or closed. We will consider the following cases (Fig. 306):—

(a) *Descending extrapolar anelectrotonus*, i.e., with a descending current we have to test the excitability of the extrapolar region at the anode. If the stimulus (common salt) applied at R (while the circuit was open) causes in this case (A) moderately strong contractions in the limb, then these at once become *weaker* or *disappear* as soon as the constant current is transmitted through the nerve. After the circuit is opened, the contractions produced by the salt again occur of the original strength.

(b) *Descending extrapolar cathelectrotonus* (A). The stimulus (salt) is at R, and the contractions thereby produced are at once *increased* after closing the polarising current. On opening it they are again weakened.

(c) *Ascending extrapolar anelectrotonus* (B). The salt lies at r . In this case we must distinguish the *strength* of the polarising current:—(1) When the current is

very weak, which can be obtained with the aid of the rheocord (Fig. 284), on closing the polarising current, there is an *increase* of the contraction produced by the salt. (2) If, however, the current is *stronger*, the contractions become either smaller or cease. This is due to the fact that, with strong currents, the conductivity of the anode is diminished or even abolished (p. 760). Although the

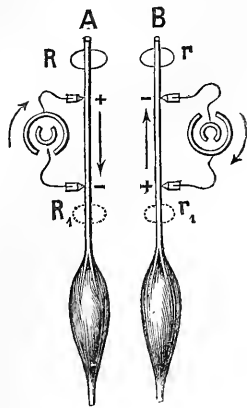

Fig. 306.

Method of testing the excitability in electrotonus— R, r, R_1, r_1 , where the common salt (stimulus) is applied.

neighbourhood of this electrode, then we cannot act upon that part of the nerve-whose excitability is influenced by the electrode. In order, therefore, to stimulate *directly* the same point on which the electrode acts, it is necessary to apply the stimulus at the same time by the electrode itself, *e.g.*, either mechanically or by conducting the stimulating current through the polarising circuit (Walter and de Watteville).

II. Proof of Electrotonus in Sensory Nerves.—Isolate the sciatic nerve of a decapitated frog. When this nerve is stimulated in its course with a saturated solution of common salt, *reflex movements* are excited in the other leg, the spinal cord being still intact. These disappear as soon as a constant current is applied to the nerve, provided the salt lies in the anelectrotonic area (Pflüger and Zurhelle, Hallstén).

III. Proof of Electrotonus in Inhibitory Nerves.—To show this, proceed thus:—On causing dyspnea in a rabbit, the number of heart-beats is diminished, owing to the action of the dyspnoic blood on the cardio-inhibitory centre in the medulla oblongata. If after dividing the vagus on one side, a constant descending current be passed through the other intact vagus, the number of pulse-beats is again increased (descending extrapolar anelectrotonus). If, however, the current through the nerve be an ascending one, then with *weak* currents the number of heart-beats increases still more (ascending extrapolar cathelectrotonus). Hence, the action of inhibitory nerves in electrotonus is the opposite of that in motor nerves.

During the electrotonus of muscle, the excitability of the intrapolar portion is altered. The delay in the conduction is confined to this area alone (*v. Bezold*)—compare § 337, 1.

salt acts on the excitable nerve, there is no contraction of the muscle, as the conduction of an impulse is prevented by the resistance in the nerve.

The law of electrotonus may also be demonstrated on a *completely isolated* nerve. The end of the nerve is properly disposed upon electrodes connected with a galvanometer, so as to obtain a *strong* current. If the nerve, when the constant current is closed, is stimulated in the anelectrotonic area, *e.g.*, by an induction shock, then the *negative variation is weaker* than when the polarising circuit was open. Conversely, it is stronger when it is stimulated in the cathelectrotonic area (Bernstein). The currents from the extrapolar areas of a nerve in a condition of electrotonus, exhibit the negative variation, when the nerve is stimulated.

Proof in Man.—In performing this experiment, it is important to remember when an electrode is applied to the skin over a nerve, that in the immediate neighbourhood of this electrode, electricity with the opposite characters is established in the nerve (*v. Helmholtz, Erb*). If we desire to stimulate in the

336. The Occurrence and Disappearance of Electrotonus—Law of Contraction.

Opening and Closing Shocks.—A nerve is stimulated both at the moment of the occurrence and that of disappearance of electrotonus, (*i.e.*, by closing and opening the current—Ritter):—1. When the current is *closed*, the stimulation occurs only at the *cathode*, *i.e.*, at the moment when the electrotonus takes place. 2. When the current is *opened*, stimulation occurs only at the *anode*, *i.e.*, at the moment when the electrotonus disappears. 3. The stimulation at the occurrence of cathelectrotonus is stronger than that at the disappearance of an-electrotonus (Pflüger).

Ritter's Opening Tetanus.—That stimulation occurs only at the anode, when the current is opened, was proved by Pflüger by means of "Ritter's opening tetanus." Ritter's tetanus consists in this, that, when a constant current is passed for a long time through a long stretch of nerve, on opening the current, tetanus lasting for a considerable time results. If the current was a descending one, then this tetanus ceases at once after section of the intrapolar area, a proof that the tetanus resulted from the now separated anode. If the current was an ascending one, section of the nerve has no effect on the tetanus.

Pflüger and v. Bezold also proved that the closing contraction at the cathode precedes that at the anode. Thus, they observed that with a descending current, the closing contraction in the muscle at the moment of closing, occurred earlier than the opening contraction at the moment of opening; and, conversely with an ascending current, the closing contraction occurred later and the opening contraction sooner. The difference in time corresponds to the time required for the propagation of the impulse in the intrapolar region (§ 337). If a large part of the intrapolar region in a frog's nerve be rendered inexcitable by applying ammonia to it, then only the electrode next the muscle stimulates, *i.e.*, always on closing a descending current, and on opening an ascending one (Biedermann).

A. **The law of contraction** is valid for all kinds of nerves—I. The contraction occurring at the closing or opening of a constant current varies with (*a*) the **direction** (Pfaff), and (*b*) the **strength** of the current (Heidenhain).

1. **Very feeble** currents, in conformity with the third of the above statements, cause only a *closing contraction*, both with an ascending and a descending current. The disappearance of electrotonus is so feeble a stimulus as not to excite the nerve.

2. **Medium** currents cause opening or closing contractions both with an ascending and a descending current.

3. **Very strong** currents cause only a *closing contraction* with a *descending* current; the opening shock does not occur, because, with very strong currents, almost the whole of the intrapolar portion of the electrotonic nerve is incapable of conducting an impulse (p. 760). *Ascending* currents cause only an *opening contraction* for the same reason.

With a certain strength of current, the muscle remains tetanic while the current is closed ("closing tetanus.")

[The law of contraction may be formulated thus :—

Strength of Current.	Ascending.		Descending.	
	On Closing.	On Opening.	On Closing.	On Opening.
Weak, . . .	C	R	C	R
Medium, . . .	C	C	C	C
Strong, . . .	R	C	C	R

R = rest ; C = contraction.]

II. In a nerve, while *dying* and losing its excitability, according to the Ritter-Valli law (§ 325, 7), the law of contraction is modified. In the stage of increased excitability, *weak* currents cause only closing contractions with both directions of the current. In the following stage, when the excitability begins to diminish, weak currents cause opening and closing contractions with both currents. Lastly, when the excitability is very greatly diminished, the descending current is followed only by a closing contraction, and the ascending by an opening contraction (Ritter, 1829).

III. As the various changes in excitability occur in a centrifugal direction along the nerve, we may detect the various stages simultaneously at different parts along the course of the nerve. According to Valentin, Fick, Cl. Bernard, and Schiff, the living intact nerve shows only a closing contraction with both directions of the current, and opening contractions only with very strong currents.

Eckhard observed that, on opening an ascending medium current applied to the hypoglossal nerve of a rabbit, one-half of the tongue exhibited a *trembling* movement instead of a contraction, while on closing a descending current, the same result occurred (§ 297, 3).

According to Pflüger, the molecules of the passive nerve are in a certain state of medium mobility. In cathelectrotonus the mobility of the molecules is increased, in anelectrotonus diminished.

B. The law for inhibitory nerves is similar. Moleschott, v. Bezold, and Donders have found similar results for the vagus, with this difference, that, instead of the contraction of a muscle, there is inhibition of the heart.

C. For sensory nerves also the result is the same, but we must remember that the perceptive organ lies at the central end of the nerve, while in a motor nerve it (muscle) is at the periphery. Pflüger studied the effect of closing and opening a current on sensory nerves, by

observing the *reflex movement* which resulted. *Weak* currents cause only closing contractions; *medium* currents, both opening and closing contractions; descending *strong* currents only opening contractions; and ascending, only closing contractions. *Weak* currents applied to the human *skin* cause a sensation with both directions of the current only at closing; *strong descending* currents, a sensation only at *opening*; *strong ascending* currents, a sensation only at closing (Marianini, Matteucci). When the current is closed there is prickly feeling, which increases with the strength of the current (Volta). Analogous phenomena have been observed in the **sense organs** (sensations of light and sound) by Volta and Ritter.

D. In **muscle**, the law of contraction is proved thus—by fixing one end of the muscle, keeping it tense, so that it cannot shorten, and opening and closing the current at this end. The end of the muscle which is free to move, shows the same law of contraction as if the motor nerve was stimulated (v. Bezold). On closing the current, the contraction begins at the cathode; on opening, at the anode (Engelmann). E. Hering and Biedermann showed more clearly that, both the closing and opening contractions are purely polar effects; when a *weak* current applied to a muscle is *closed*, the first effect is a small contraction limited to the cathodic surface of the muscle. Increase of the current causes increased contraction, which extends to the anode, but which is weaker there than at the cathode; at the same time, the muscle *remains contracted* during the time the current is closed. On *opening*, the contraction begins at the anode; even after opening, the muscle for a time may remain contracted, which ceases on closing the current in the same direction.

By killing the end of a muscle in various ways, the excitability is diminished near this part. Hence, at such a place the polar action is feeble (van Loon and Engelmann, Biedermann). Touching a part with extract of flesh, potash, or alcohol diminishes locally the polar action, while soda salts, and veratrin increase it (Biedermann).

Closing Continued Contraction.—The moderate continued contraction, which is sometimes observed in a muscle while the current is closed (Fig. 248, Ö), depends upon the abnormal prolongation of the closing contraction at the cathode when a strong stimulus is used, or during the stage of dying, or in cooled winter frogs; sometimes the opening of the current is accompanied by a similar contraction proceeding from the anode (Biedermann). This tetanus is also due to the summation of a series of simple contractions (§298, III). By acting on a muscle with a 2 per cent. saline solution containing sodic carbonate, the duration of the contraction is increased considerably, and occasionally the muscle shortens rhythmically (Biedermann).

If the whole muscle is placed in the circuit, the closing contraction is strongest with both directions of the current; during the time the current is closed, a continued contraction is strongest when the current is ascending (Wundt).

Ritter's Opening Tetanus.—If a nerve or muscle be traversed by a constant current for some time, we often obtain a prolonged *tetanus*, after opening the current (Ritter's opening tetanus, 1798). It is set aside by closing the original current, while closing a current in the opposite direction increases it ("*Volta's alternative*"). The continued passage of the current increases the excitability for the opening of the current in the same direction, and for the closing of the reverse current; conversely, it diminishes it for the closing of the current in the same direction, and for the opening of the reverse current (Volta, Rosenthal, Wundt).

In a nerve-muscle preparation used to prove the law of contraction, of course, a demarcation current is developed in the nerve (§ 334, II.). If an artificial weak stimulating current be applied to such a nerve, we obtain an interference effect due to these two currents; closing a weak current causes a contraction, which, however, is not properly a closing contraction, but depends upon the opening of a branch of the demarcation current; conversely, the opening of a weak current may excite a contraction, which is really due to the closing of a side branch of the nerve-current in a secondary circuit through the electrodes (Hering, Biedermann, Grützner). According to Grützner and Tiegerstedt, the cause of the opening contraction is partly due to the occurrence of polarising after currents (§ 333).

Engelmann and Grünhagen explain the occurrence of opening and closing tetanus, thus—as due to latent stimulations, drying, variations of the temperature of the prepared nerve, which of themselves are too feeble to cause tetanus, but which become effective if an increased excitability obtains at the cathode after closure, and at the anode after opening the current.

Biedermann showed that, under certain conditions, two successive opening contractions can be obtained in a frog's nerve-muscle preparation, the second and later one corresponding to Ritter's tetanus. The first of these contractions is due to the disappearance of anelectrotonus in Pflüger's sense, the second is explained, like Ritter's opening tetanus, in Engelmann and Grünhagen's sense.

Fleischl's Law of Contraction.—v. Fleischl and Stricker have stated a different law in respect to the fact that the excitability varies at certain points in the course of a nerve. The sciatic nerve is divided into three areas:—(1) stretches from the muscle to the place where the branches for the thigh muscles are given off; (2) from here to the intervertebral ganglion; (3) from here into the spinal cord. Each of these three areas consists of two parts ("upper and lower pole"), which adjoin each other at an equator. In each upper pole, the excitability of the nerve is greater for descending currents, and in each lower pole for ascending ones. At each equator, the excitability of the nerve is the same for ascending and descending currents. The difference in the activity, due to the direction of the current, is greater for each stretch of nerve the greater this stretch is distant from the equator. The excitability is less at those points of the nerve where the three areas join each other.

337. Rapidity of Transmission of Nervous Impulses.

1. If a *motor* nerve be stimulated at its central end, an *impulse* is transmitted along the nerve to the muscle with a certain velocity, which is about $27\frac{1}{4}$ metres [about 90 feet] per second (v. Helmholtz),

and for the human motor nerves 33.9 [100–120 feet per second] (v. Helmholtz and Baxt).

The velocity is less in the **visceral nerves**, *e.g.*, in the pharyngeal branches of the vagus 8.2 metres [26 feet] (Chauveau); in the motor nerves of the lobster 6 metres [18 feet] (Frédéricq and van der Velde).

Modifying Conditions.—The velocity is influenced by various conditions: *Temperature*—It is *lessened* considerably by cold (v. Helmholtz), but both high and low temperatures of the nerve (above or below 15°–25°C.) lessen it (Steiner and Trojtzky); also *curara*, the *electrotonic condition* (v. Bezold); or only *anelectrotonus*, while *cathelectrotonus* increases it (Rutherford, Wundt). It varies also with the length of the conducting nerve, but it increases with the strength of the stimulus (v. Helmholtz and Baxt), although not at first (v. Vintschgau).

Methods.—1. v. Helmholtz (1850) estimated the velocity of the nerve-impulse in a frog's motor nerve, after the method of Pouillet. The method depends upon the fact that the needle of a galvanometer is deflected by a current of very short duration; the extent of the deflection being proportional to the duration and strength of the

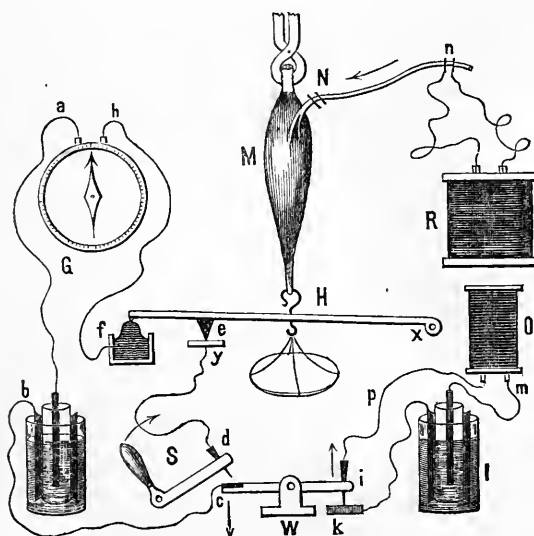

Fig. 307.

v. Helmholtz's method of estimating the velocity of propagation of a nerve-impulse in a nerve.

current. The apparatus is so arranged that the "time-marking current" is closed at the moment the nerve is stimulated, and opened again when the muscle contracts. If the nerve attached to a muscle be now stimulated at the further point from the muscle, and a second time near its entrance to the muscle, then in the latter case, the time between the application of the stimulus and the beginning

of the contraction of the muscle, *i.e.*, the deflection of the galvanometer, will be less than in the former case, as the impulse has to traverse the whole length of the nerve to reach the muscle. The difference between the two times is the time required by the impulse to traverse a given distance of nerve. Fig. 307 shows in a diagrammatic manner the arrangement of the experiment. The *galvanometer*, G, is placed in the time-marking circuit (open at first), *a, b* (element), *c* (piece of platinum on a key, W), introduced into the time-marking circuit, *d, e, f, h*. The circuit is made by closing the key, S, when *d* depresses the platinum plate of the key, W. At once, when the current is closed, the magnetic needle is deflected, and its extent noted. At the same moment in which the current between *c* and *d* is closed, the primary circuit of the *induction machine* is opened, the circuit being *i, k, l* (element), *m, O* (primary spiral), *p*. Thereby an *opening shock* is induced in the secondary spiral, R, which stimulates the nerve of the frog's leg at *n*. Thus, the closing of the galvanometer circuit exactly coincides with the stimulation of the nerve. The impulse is propagated through the nerve to the muscle, M, and the latter contracts when the impulse reaches it, at the same time opening the time-measuring circuit at the double contact, *e* and *f*, by raising the lever, H, which rotates on *x*. At the moment of opening, the further deflection of the magnetic needle ceases. The contact at *f* is made by a pointed cupola of mercury. When the lever, H, falls after the contact of the muscle, so that the point, *e*, comes into contact with the underlying *solid* plate, *y*, the contact at *f* still remains open, *i.e.*, through the galvanometer circuit. If the nerve be stimulated with the opening shock, first at *n*, and then at N, the deflection of the needle is greater in the former than in the latter case. From the difference, we calculate the *time* for the conduction of the impulse in the stretch of the nerve between *n* and N.

[2. A simpler method is that shown in the scheme, Fig. 308. Use a pendulum or spring myograph (Fig. 242), and suspend a frog's gastroc-

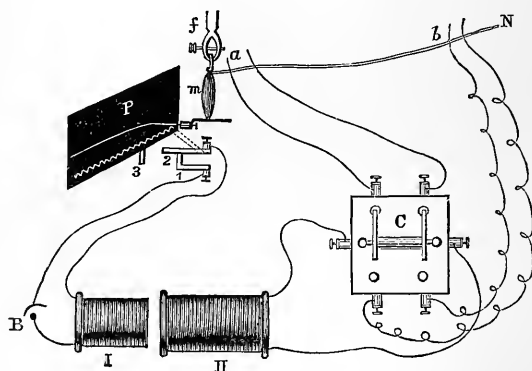

Fig. 308.

Scheme of the arrangement for measuring the velocity of nerve-energy in a nerve—*f*, clamp for femur; *m*, muscle; N, nerve; *a*, near muscle; *b*, removed from it; C, commutator; II, secondary; I, primary spiral of induction machine; B, battery; 2, 1, key; 3, tooth on the smoked plate P.

nemius (*m*), with a long portion of the sciatic nerve (N) dissected out, by fixing the femur in a clamp (*f*), while the tendo achilles is fixed to a

lever, which inscribes its movements on the smoked glass plate (P) of the myograph; place the key of the myograph (2) in the circuit with the battery (B), and the primary circuit of the induction machine (I). To the secondary coil (II) attach two wires, and connect them with a commutator *without cross-bars* (C). Connect the other binding screws of the commutator with two pairs of wires, arranged so that one pair can stimulate the nerve near the muscle (*a*), and the other at a distance from it (*b*). When the glass plate swings from one side to the other, the tooth (3) on its framework opens the key (2) in the primary circuit, and if the commutator be in the position indicated, then the induced current will stimulate the nerve at *a*, and a curve will be obtained on the glass plate. Rearrange the pendulum as before, but turn the handle of the commutator, and allow the pendulum to swing again. This time the induced current will stimulate the nerve at *b*, and a second contraction a *little later* than the first one will be obtained. Register the

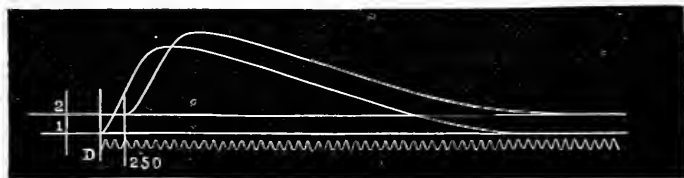

Fig. 309.

- 1, Curve obtained on stimulating a nerve (man) near the muscle; 2, when the stimulus was applied to the nerve at a distance from the muscle; D, vibrations of a tuning-fork (250 per second—Marey).

velocity of the swing by means of a tuning-fork, and the curve obtained will be something like Fig. 309, although this curve was obtained on a cylinder travelling at a uniform rate. The difference between the beginning of the *a* and *b* curves, indicates the time that the nerve-impulse took to travel from *b* to *a*. This time is measured by the tuning-fork, and if the distance between the points *a* and *b* is known, then the calculation is a simple one. Suppose the stretch of nerve between *a* and *b* to be two inches, and the time required by the impulse to travel from *b* to *a* to be $\frac{1}{480}$ second, then we have the simple calculation—2 inches : 12 inches :: $\frac{1}{480}$ " : $\frac{1}{80}$ ", or 80 feet per second. In Fig. 309, the experiment was made on man; the curve 1 was obtained by stimulating the nerve near the muscle, and 2 when the nerve was stimulated at a distance of 30 centimetres. The interval between the vertical lines corresponds to $\frac{1}{100}$ second, *i.e.*, the time required by the nerve-impulse to pass along 30 centimetres of nerve, which is equal to a velocity of 30 metres (90 feet) per second.]

In man, v. Helmholtz and Baxt estimated the velocity of the impulse in the *median nerve*, by causing the muscles of the ball of the thumb to write off their contractions, on a rapidly revolving cylinder. [In this case, the pince myographique of Marey (p. 646) may be used. The ends of the pince are applied so as to embrace the ball of the thumb, so that when the muscles contract, the increase in *thickness* of the muscles expands the pince, which acts on a Marey's tambour, by which the movement is transmitted to another tambour provided with a writing-style, and inscribing its movements upon a rapidly moving surface, either rotatory or swinging.] The nerve is stimulated at one time in the axilla, and again at the wrist. Two curves are obtained, which, of course, do not begin at the same time. The difference in time between the beginning of the two curves, is the time taken by the impulse to traverse the above-mentioned length of nerve. [The time is easily ascertained by causing a tuning-fork of a known rate of vibration to write its movements under the curves.]

3. In the *sensory nerves* of man, the velocity of the impulse is probably about the same as in motor nerves. The rates given vary between 94–30 metres [280–90 feet] per second (v. Helmholtz, Kohlrausch, v. Wittich, Schelske, and others).

Method.—Two points are chosen as far apart as possible, and at unequal distances from the brain, and they are successively excited by a momentary stimulus—*e.g.*, an opening induction shock applied successively to the tip of the ear and the great toe. The moment the stimulus is applied, it is indicated on the registering surface. The person experimented on is provided with a key attached to an electric arrangement, by which he can mark on the registering surface the moment he feels the sensation in each case.

Reaction Time.—The time which elapses between the application of the stimulus and the reaction is called the "*reaction time*." It is made up of the time necessary for conduction in the sensory nerve, that for the process of perception in the brain, the conduction in the motor nerves to the muscles, by which the signs on the registering surface were made, and lastly by the latent period (p. 647). The reaction time is usually about 0.125–0.2 second.

Pathological.—The conduction in the cutaneous nerves is sometimes greatly *delayed*, in alterations of the cutaneous sensibility in certain diseases of the spinal cord (§ 364). The *sensation* itself may be unchanged. Sometimes only the conduction for painful impressions is retarded, so that a painful impression on the skin is first perceived as a tactile sensation, and afterwards as pain, or conversely. When the interval of time between these two sensations is long, then there is a distinctly *double* sensation (Naunyn, Remak, Eulenburg).

It is rarely that voluntary movements are executed much more slowly from causes depending on the *motor* nerves, but occasionally the time between the voluntary impulse and the contraction is lengthened, but there may be in addition slower or longer continued contraction of the muscle. In *tabes dorsalis* or *locomotor ataxia*, the discharge of *reflex movements* is delayed; it is slower with heat stimuli (60°) than with cold ones (5°C.—Ewald).

338. Double Conduction in Nerves.

Conductivity is that property of a living nerve in virtue of which, on the application of a stimulus, it transmits an *impulse*. [The *nature* of a nerve-impulse is entirely unknown, but we may conveniently term the process, *nerve-motion*.] The conductivity is *destroyed* by all in-

fluences or conditions which injure the nerve in its *continuity* (section, ligature, compression, destruction by chemical agents); or which abolish the *excitability* at any part of its course (absolute deprivation of blood; certain poisons—*e.g.*, curara for motor nerves; also strong anelectrotonus, p. 760).

Law of Isolated Conduction.—Conduction always takes place only in the continuity of fibres, the impulse never being transferred to adjoining nerve-fibres.

Double Conduction.—Although apparently conduction in motor nerves takes place only in a *centrifugal* direction towards the muscles, and in sensory nerves in a *centripetal* direction—*i.e.*, towards the centre; nevertheless, experiment has proved that a nerve conducts an impulse in *both* directions. If a pure motor or sensory nerve be stimulated in its course, an impulse is propagated at the same time in a centrifugal and in a centripetal direction. This is the phenomenon of "*double conduction.*"

Proofs.—1. If a nerve be stimulated, its *electro-motive properties* are affected both above and below the point of stimulation (see *Negative Variation in Nerves*, p. 754).

2. **Union of Motor and Sensory Nerves.**—If the hypoglossal and lingual nerves be divided in a dog, and if the peripheral end of the hypoglossal be stitched, so as to unite with the central end of the lingual (Bidder), then, several months after the union and restitution of the nerves, stimulation of the central end of the lingual causes contraction in the corresponding half of the tongue. Hence, it has been assumed that the lingual, which is the *sensory* nerve of the tongue, must conduct the impulse in a peripheral direction to the end of the hypoglossal.

This experiment is not conclusive, as the trunk of the lingual receives high up, the centrifugal fibres from the seventh—*viz.*, the chorda tympani, which may unite with those of the hypoglossal. Further, if the chorda be divided and allowed to degenerate before the above described experiment is made, then no contractions occur on stimulating the lingual above the point of union (§ 349).

3. **Bert's Experiment.**—Paul Bert removed the skin from the tip of the *tail of a rat*, and stitched it into the skin of the back of the animal, where it united with the tissues. After the first union had taken place, the tail was then divided at its base, so that the tail, as it were, grew out of the skin on the back of the animal. On stimulating the tail, the animal exhibited signs of sensation, so that the impulses in the sensory nerves must have traversed the nerves from the base to the tip of the tail (p. 730).

4. **Electrical Nerves.**—If the free-end of the electrical centrifugal nerves of the malapterurus be stimulated, the branches given off above

the point of stimulation are also excited, so that the whole electrical organ may discharge its electricity (Babuchin, Mantey).

339. Therapeutic Applications of Electricity— Reaction of Degeneration.

Electricity is frequently employed for therapeutical purposes, the rapidly interrupted current of the induction machine, or *faradic current* (p. 746), being frequently used (especially since Duchenne, 1847), the *magneto-electrical apparatus* (p. 747), and the *extra current apparatus* (p. 742). The *constant* or galvanic current is also used—p. 737 (especially since Remak, 1855).

1. In **paralysis**, *faradic* currents are applied either to the muscles themselves (Duchenne), or the points of entrance of the motor nerves (v. Ziemssen), by means of suitable electrodes, or rheophores covered with sponge, &c., and moistened. Directions are given at p. 620, for determining the position of entrance of the nerve.

[**Rheophores.**—Many different forms are used according to the organ or part to be stimulated, or the effect desired. When electricity is applied to the skin to remove anæsthesia, hyperæsthesia, or altered sensibility, and we desire to limit the effect to the skin alone, then the rheophores are applied *dry*, and are usually made of metal. If, however, deeper-seated structures, as muscles or nerve-trunks are to be affected, the skin must be well *moistened* and softened by sponging with warm water, while the rheophores are fitted with sponges moistened with common

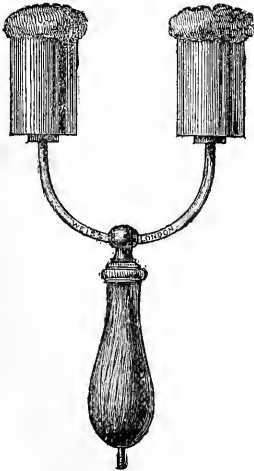

Fig. 310.

Double sponge rheophore.



Fig. 311.

Disk rheophore.



Fig. 312.

Metallic brush (Weiss).

salt and water, which diminishes the resistance of the skin to the passage of electricity.]

In faradising the paralysed muscle, the object is to cause artificial movements in it, and thus prevent the degeneration which it would otherwise undergo, merely from inaction. If in addition to the motor nerves, its *trophic* nerves are also paralysed, then a muscle atrophies, notwithstanding the faradisation (§ 325, 4).

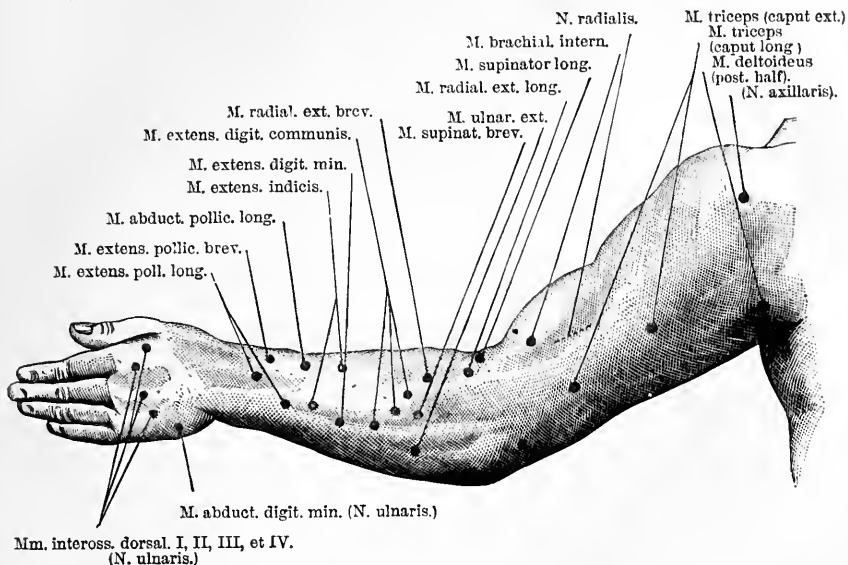

Fig. 313.

Motor points of the radial nerve and the muscles supplied by it. Dorsal surface of the arm (after Eichhorst).

The Figs. 313, 314, 315, and 316, indicate the positions of the motor points of the extremities, where, by stimulating at the entrance of the nerve, each muscle may be caused to contract singly. In § 349, the motor points of the face, and in § 347, those of the neck, are indicated.

The use of the induced current also improves a paralysed muscle, as it increases the *blood-stream* through it, while it affects the *metabolism* of the muscle reflexly. In addition, weak currents may restore the excitability of enfeebled nerves (v. Bezold, Engelmann).

The **constant current** may be employed as a stimulus, when it is closed and opened in the form of an *interrupted* current, by altering its direction, and increasing or diminishing its intensity, but it also causes a *polar action*. On *closing* the current, the nerve at the *cathode* is stimulated; similarly, on *opening* the current, at the *anode* (§ 336). Thus, when the current is closed, the excitability of the nerve is increased at the cathode (§ 335), which may act favourably upon the nerve. Increased excitability in electrotonus at the anode, although feebler, has been observed during percutaneous galvanisation in man. This is especially the case by repeatedly reversing the current, sometimes also by opening and closing, or even with a uniform current. If the increase of the excitability is obtained, then the direction of the current increases the excitability on closing the reverse current, and on opening the one in the same direction.

Restorative Effect.—Further, in using the constant current, we have to consider its restorative effects, especially when it is *ascending*. R. Heidenhain

found, that feeble and fatigued muscles recover after the passage of a constant current through them.

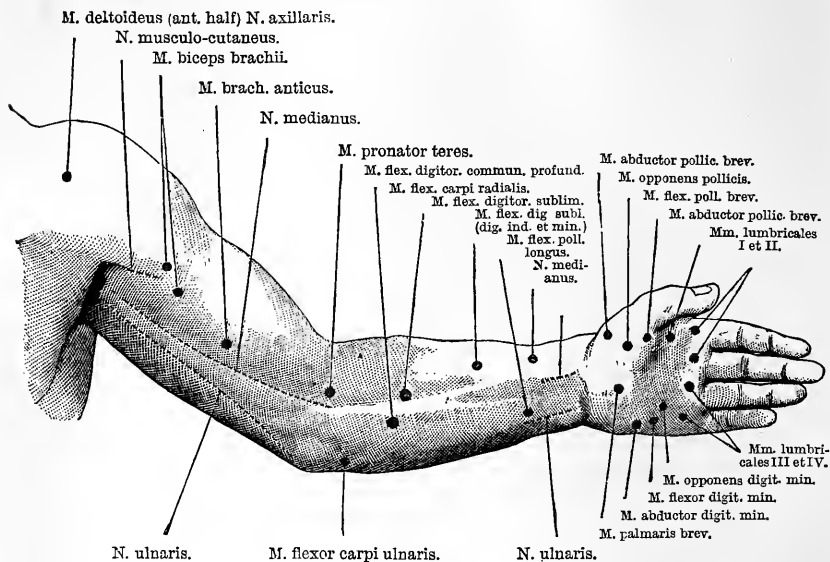

Fig. 314.

Motor points of the median and ulnar nerves, with the muscles supplied by them; the volar surface of the arm (after Eichhorst).

Lastly, the constant current may be useful from its *catalytic* or *cataphoric* action (p. 742). The effect is directly upon the tissue elements. It may also act directly or reflexly upon the blood- and lymph-vessels.

Faradisation in Paralysis.—If the primary cause of the paralysis is in the muscles themselves, then the *induced* current is generally applied directly to the muscles themselves by means of sponge electrodes (Fig. 310); while, if the motor nerves are the primary seat, then the electrodes are applied over them. The current used must be only of *very moderate* strength; strong tetanic contractions are injurious, and so is too prolonged application (Alb. Eulenburg).

The **galvanic current** may also be applied to the muscles or to their motor nerves, or to the centres of the latter, or to both muscle and nerve simultaneously. As a rule, the *cathode* is placed *nearer the centre*, as it increases the excitability. When the electrode is moved along the course of the nerve, or when the strength of the current is varied, the action is favoured. If the seat of the lesion is in the central nervous system, then the electrodes are applied along the vertebral column, or on the vertebral column and the course of the nerves at the same time, or one on the head and the other on a point as near as possible to the supposed seat of the lesion. The current must not be too strong, nor applied too long.

Induced v. Constant Current: Reaction of Degeneration.—Paralysed nerves and muscles behave quite differently as regard the *induced* (rapidly interrupted) and the *constant* current. This is called the "*reaction of degeneration.*" We must remember the physiological fact that a *dying* nerve attached to a muscle (p. 731), and also the muscles of a curarised animal, react much less strongly to rapidly interrupted currents than fresh non-curarised muscles. Baier-

lach, in 1859, found that in a case of facial paralysis, the facial muscles contracted but feebly to the induced current, but very energetically on the constant current being used. The excitability for the constant current may be abnormally increased, but may disappear on recovery taking place. According to Neumann,

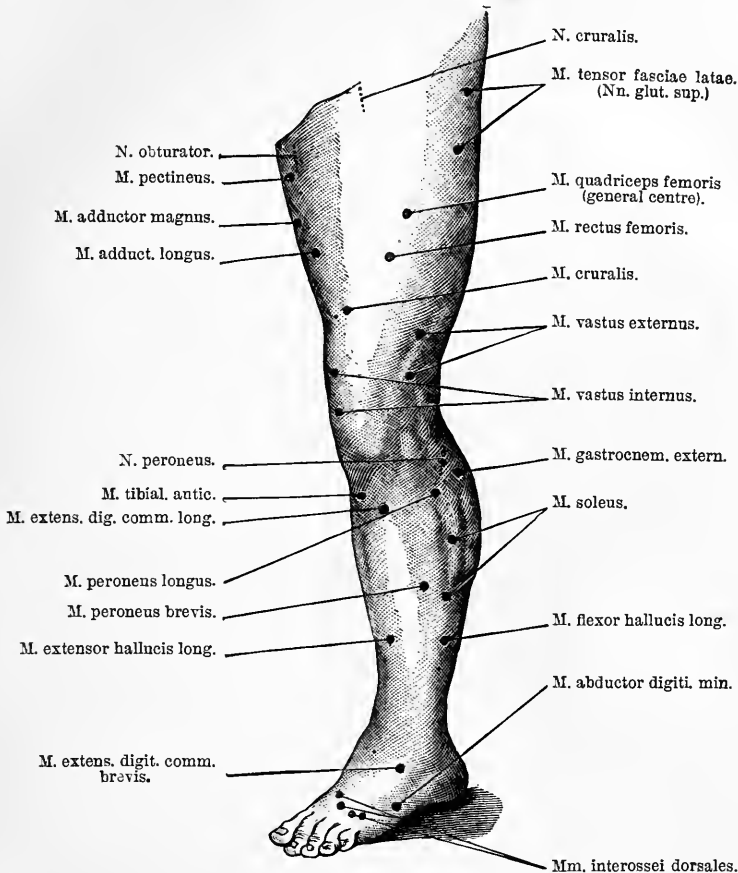

Fig. 315.

Motor points of the peroneal and tibial nerves on the front of the leg; the peroneal on the left, the tibial on the right (after Eichhorst).

it is the longer duration of the constant current, as opposed to the momentary closing and opening of the induced current, which makes the contraction of the muscle possible. If the constant current be broken as rapidly as the faradic current is broken, then the constant current does not cause contraction. Conversely, the induced current may be rendered effective by causing it to last longer. We may also keep the primary circuit of the induction machine closed, and move the secondary spiral to and fro along the slots. Thus we obtain slow gradations of the induced current, which act energetically upon curarised muscles (Brücke). Hence, in stimulating a muscle or nerve, we have to consider not only the *strength*, but also the *duration*, of the current, just as the deflection of the magnetic needle depends upon these two factors.

[Galvanic excitability is the term applied to the condition of a nerve or muscle whereby it responds to the opening or closing of a continuous current. The effects differ according as the current is opened or closed, and according to its strength. As a rule, the cathode causes a contraction chiefly at closure, the anode at opening the current, while the cathode is the stronger stimulus. With a *weak* current, the cathode produces a simple contraction on closing the current, but no contraction from the anode. With a *medium* current, we get with the

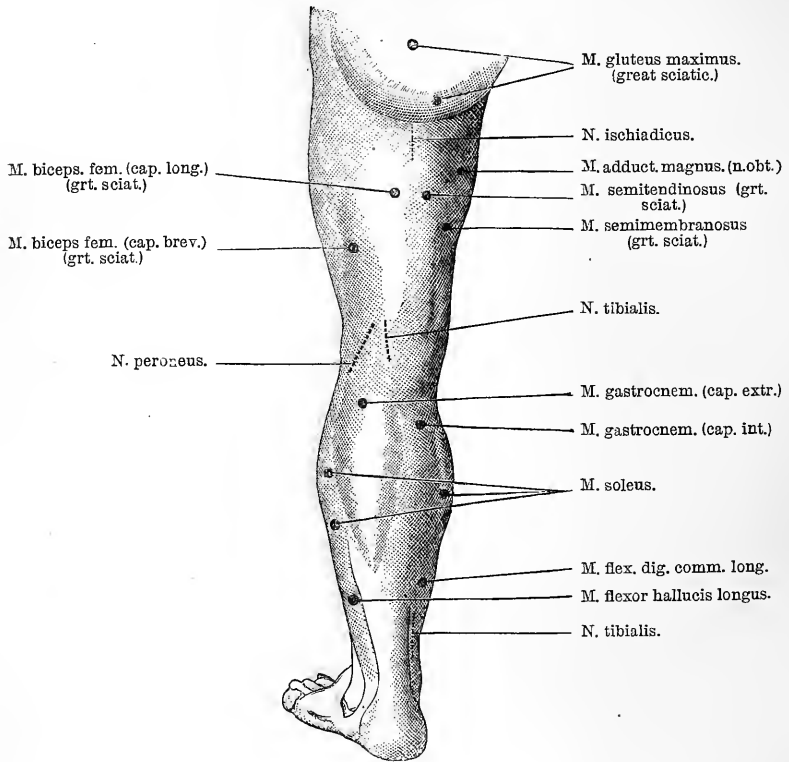

Fig. 316.

Motor points of the sciatic nerve and its branches; the peroneal and tibial nerves (after Eichhorst).

cathode a strong closing contraction but no opening contraction, while the anode excites feeble opening and closing contractions. With a *strong* current, we get with the cathode a tetanic contraction at closure, and a perceptible contraction at opening, while with the anode there is contraction both at opening and closing.]

[The **law of contraction** is usually expressed by the following formula (Ross, after Erb):—An = anode, Ca = cathode, C = contraction, *c* = feeble contraction, C' = strong contraction, S = closure of current, O = opening of current, Te = tetanic contraction—so that, expressing the above statements briefly, we have—

Weak currents produce	Ca S C ;
Medium ,, ,,	Ca S C', An S c, An O c ;
Strong ,, ,,	Ca S Te, An S C, An O C. Ca Oc.]

[**Typical Reaction of Degeneration.**—When the reaction of the nerve and muscle to electrical stimulation is altered both *qualitatively* and *quantitatively*, we have the reaction of degeneration, which is characterised essentially by the following conditions]:—The excitability of the *muscles* is diminished or abolished for the faradic current, while it is increased for the galvanic current from the 3rd–58th day; it again diminishes, however, with variations, from the 72nd–80th day; the anode closing contraction is stronger than the cathode closing contraction. The contractions in the affected muscles occur slowly in a peristaltic manner, and are local, in contrast with the rapid contraction of a normal muscle. The diminution of the excitability of the *nerves* is similar for the galvanic and faradic currents. If the reaction of the nerves be normal, while the muscle during direct stimulation with the constant current exhibits the reaction of degeneration, we speak of “*partial reaction of degeneration*” (Erb), which is constantly present in progressive muscular atrophy (Erb, Günther).

[The “reaction of degeneration” may occur before there is actual paralysis, as in lead poisoning. When it occurs we have to deal with some affection of the nerve-fibres, or of the trophic nerve-cells. When it is established, (1) stimulation of the nerve with faradic and galvanic electricity does not cause contraction of the muscle; (2) direct faradic stimulation of the muscles does not cause contraction; (3) the galvanic current usually excites contraction more readily than in a normal muscle, so that the muscle responds to much feebler currents than act on healthy muscles, but the contraction is longer and more of a tonic character, and shows a tendency to become tetanic.]

[The electrical excitability is generally unaffected in paralysis of cerebral origin, and in some forms of spinal paralysis, as primary lateral sclerosis and transverse myelitis (Ross), but the “reaction of degeneration” occurs in traumatic paralysis, due to injury of the nerve-trunks, neuritis, rheumatic facial paralysis, lead palsy, and in affections of the nerve-cells in the anterior cornu of the grey matter of the spinal cord.]

In rare cases, the contraction of the muscles, caused by applying a *faradic* current to the nerve, follows a slow peristaltic-like course—“*faradic reaction of degeneration*” (E. Remak, Kast, Erb).

II. In Various Forms of Spasm (spasms, contracture, muscular tremor) the *constant current* is most effective (Remak). By the action of anelectrotonus, a pathological increase of the excitability is subdued. Hence, the anode ought to be applied to the part with increased excitability, and if it be a case of reflex spasm, to the points which are the origin or seat of the increased excitability. Weak currents of uniform intensity are most effective. The constant current may also be useful from its *cataphoric* action, whereby it favours the removal of stimuli from the seat of the irritation. Further, the constant current increases the *voluntary control* over the affected muscles. In spasms of central origin, the constant current may be applied to the central organ itself (Fig. 323).

Faradisation is used in spasmodic affections to increase the vigour of enfeebled antagonistic muscles. Muscles in a condition of contracture are said to become more extensible under the influence of the faradic current (Remak), as a normal muscle is more excitable during active contraction (§ 301).

In *cutaneous anæsthesia*, the *faradic current* applied to the skin by means of hair-brush electrodes (Fig. 312) is frequently used. When using the *constant current*, the

cathode must be applied to the parts with diminished sensibility. The constant current alone is applied to the *central* seat of the lesion, and care must be taken to what extent the occurrence of cathelectrotonus in the centre affects the occurrence of sensation.

III. In **Hyperæsthesia and Neuralgias**, faradic currents are applied with the object of over-stimulating the hyper-sensitive parts, and thus to benumb them. Besides these powerful currents, *weak* currents act *reflexly* and accelerate the blood-stream, increase the heart's action, and constrict the blood-vessels, while *strong* currents cause the opposite effects (O. Naumann). Both may be useful.

In employing the *constant current in neuralgia* (Remak), one object is by exciting anelectrotonus in the hyper-sensitive nerves, to cause a diminution of the excitability. According to the nature of the case, the anode is placed either on the nerve-trunk, or even on the centre itself, and the cathode on an indifferent part of the body. The *catalytic* and *cataphoric* effects also are most important, for by means of them, especially in recent rheumatic neuralgias, the irritating inflammatory products are distributed and conducted away from the part. A descending current is transmitted continuously for a time through the nerve-trunk, and in recent cases its effects are sometimes very striking. Lastly, of course the constant current may be used as a *cutaneous stimulus*, while the faradic current also acts reflexly on the cardiac and vascular activity.

Recently, Charcot and Ballet have used the electric spark from an electrical machine in cases of anæsthesia, facial paralysis, and paralysis agitans. In some cases of spinal paralysis, muscles can be made to contract with the electric spark, which do not contract to a faradic current.

[Electricity is sometimes used to distinguish real from feigned disease, or to distinguish death from a condition of trance].

Galvano-cautery.—The electrical current is used for *thermal* purposes, as in the galvano-cautery.

Galvano-puncture.—The *electrolytic* properties of electrical currents are employed to cause coagulation in aneurisms or varix.

[If the electrodes from a constant battery in action be inserted in an aneurismal sac, after a time the fibrin of the blood is deposited in the sac, whereby the cavity of the aneurism is gradually filled up. A galvanic current passed through defibrinated blood causes the formation of a coagulum of proteid matter at the positive pole and bubbles of gas at the negative].

340. Electrical Charging of the Body.

Saussure investigated by means of the electroscope the "charge" of a person standing on an insulated stool. The phenomena observed by him, which were always inconstant, were due to the *friction* of the clothes upon the skin. Gardini, Hemmer, Ahrens (1817), and Nasse regarded the body as normally charged with *positive* electricity, while Sjösten and others regarded it as *negatively* charged. Most probably all these phenomena are due to friction, and are modified effects of the air in contact with the heterogeneous clothing (Hankel).

A strong charge resulting in an actual spark has frequently been described. Cardanus (1553) obtained sparks from the tips of the hair of the head. According to Horsford (1837), long sparks were obtained from the tips of the fingers of a nervous woman in Oxford, when she stood upon an insulated carpet. Sparks have often been observed on combing the hair or stroking the back of a cat in the dark. Freshly voided *urine* is negatively electrical (Vasalli-Eandi, Volta); so is the freshly formed web of a spider, while the *blood* is positive.

341. Comparative—Historical.

Electrical Fishes.—Some of the most interesting phenomena connected with animal electricity are obtained in electrical fishes, of which there are about fifty species, including the electrical eel, or *Gymnotus electricus*, of the lagoons of the region of the Orinoco in South America; it may measure over seven feet in length. The *Torpedo marmorata* and some allied species, 30–70 centimetres [$1-2\frac{1}{2}$ feet], in the Adriatic and Mediterranean, the *Malapterurus electricus* of the Nile, and the *Marmyrus* also of the same river. By means of special *electrical organs* (Redi, 1666), these animals can partly voluntarily (*gymnotus* and *malapterurus*), and partly reflexly (*torpedo*) give a very powerful electrical shock. The electrical organ consists of “compartments” of various forms, separated from each other by connective-tissue, and filled with a jelly-like substance, which the nerves enter on one surface, and ramify to produce a plexus. From this plexus there proceed branches of the axial cylinder, which end in a nucleated plate, the “electrical plate” (Billharz, M. Schulze). When the “electrical nerves” proceeding to the organ are stimulated, an electrical discharge is the result.

In *Gymnotus*, the electrical organ consists of several rows of columns arranged along both sides of the spinal column of the animal, under the skin as far as the tail. It receives on the anterior surface several branches from the intercostal nerves. Besides this large organ, there is a smaller one lying on both sides above the anal fins. Here the plates are vertical, and the direction of the electrical current in the fish is ascending, so that of course it is descending in the surrounding water (Faraday, du Bois-Reymond).

In *Malapterurus*, the organ surrounds the body like a mantle, and receives only one nerve-fibre (p. 715), whose axis cylinder arises near the medulla oblongata from one gigantic ganglionic cell (Bittharz), and is composed of protoplasmic processes (Fritsch). The plates are also vertical, and receive their nerves from the posterior surface. The direction of the current is descending in the fish during the discharge (du Bois-Reymond).

In the *Torpedo*, the organ lies immediately under the skin laterally on each side of the head, reaching as far as the pectoral fins. It receives several nerves which arise from the lobus electricus, between the corpora quadrigemina and the medulla oblongata. The plates which do not increase in number with the growth of the animal (Delle Chiaje, Babuchin) lie horizontally, while the nerve-fibres enter them on their dorsal surfaces; the current in the fish being from the abdominal to the dorsal surface (Galvani).

It is extremely probable that the electric organs are modified muscles, in which the nerve terminations are highly developed, the electrical plates corresponding to the motorial end-plates of the muscular fibres, the contractile substance having disappeared, so that during physiological activity, the chemical energy is changed into electricity alone, while there is no “work” done. This view is supported by the observation of Babuchin, that during development, the organs are originally formed like muscles; further, that the organs when at rest are neutral, but when active or dead, acid; and lastly, they contain a substance related to myosin which coagulates after death (§ 295—Weyl). The organs manifest fatigue; they have a “latent period” of 0·016 second, while one shock of the organ (comparable to the current in an active muscle), lasts 0·07 second. About 25 of these shocks go to make a discharge, which lasts about 0·23 second. The discharge, like tetanus, is a discontinuous process (Marey). Mechanical, chemical, thermal, and electrical stimuli cause a discharge; a single induction shock is not effective (Sachs). During the electrical discharge, the current traverses the muscles of the animal itself; the latter contract in the *torpedo*, while they do not do so in the *gymnotus* and

malapterurus during the discharge (Steiner). A torpedo can give about 50 shocks per minute; it then becomes fatigued, and requires some time to recover itself. It may only partially discharge its organ (Al. v. Humboldt, Sachs). Cooling makes the organ less active, while heating it to 22°C. makes it more so. The organ becomes tetanic with strychnin (Becquerel), while curara paralyses it (Sachs). Stimulation of the electrical organ of the torpedo causes a discharge (Matteucci); cold retards it, while section of the electrical nerves paralyses the organ. The electrical fishes themselves are but slightly affected by very strong induction shocks transmitted through the water in which they are swimming (du Bois-Reymond). The substance of the electrical organs is singly refractive; excised portions give a current during rest, which has the same direction as the shock; tetanus of the organ weakens the current (Sachs, du Bois-Reymond).

Historical.—Richer (1672) made the first communication about the gymnotus. Walsh (1772) made investigations on the torpedo, on its discharge, and its power of communicating a shock. J. Davy magnetised particles of steel, caused a deflection of the magnetic needle, and obtained electrolysis with the electrical discharge. Becquerel, Brechet, and Matteucci studied the *direction* of the discharge. Al. v. Humboldt described the habits and actions of the gymnotus of South America.

Hausen (1743) and de Sauvages (1744) supposed that electricity was the active force in nerves. The actual investigations into animal electricity began with G. Aloisio Galvani (1791), who observed that frogs' legs connected with an electrical machine contracted, and also when they were touched with two different metals. He believed that nerves and muscles generated electricity. Alessandro Volta ascribed the second experiment to the electrical current produced by the contact of dissimilar metals, and, therefore, outside the tissues of the frog. The contraction without metals described by Galvani, was confirmed by Alex. v. Humboldt (1798). Pfaff (1793) first observed the effect of the direction of the current upon the contraction of a frog's leg obtained by stimulating its nerve. Bunzen made a galvanic pile of frogs' legs. The whole subject entered on a new phase with the construction of the galvanometer, and since the classical methods of du Bois-Reymond—*i. e.*, from 1843 onwards.

Physiology of the Peripheral Nerves.

342. Classification of Nerve-Fibres according to their Function.

AS nerve-fibres, on being stimulated, are capable of conducting impulses in both directions (p. 770), it is obvious that the physiological position of a nerve-fibre must depend essentially upon its relations to the *peripheral end-organ* on the one hand, and its *central* connection on the other. Thus, each nerve is distributed to a special area within which, under normal circumstances, in the intact body, it performs its functions.

I. Centrifugal or Efferent Nerves.

(a.) **Motor.**—Those nerve-fibres whose peripheral end-organ consists of a *muscle*, the central ends of the fibres being connected with nerve-cells:—

1. Motor fibres of *striped muscle* (§§ 292-320).
2. Motor nerves of the *heart* (§ 57).
3. Motor nerves of *smooth muscle*, e.g., the intestine (§ 161). The *vaso-motor* nerves are specially treated of in § 371.

(b.) **Secretory.**—Those nerve-fibres whose peripheral end-organ consists of a *secretory cell*, the central ends of the fibres being connected with nerve-cells.

As *examples* of secretory nerves, take the secretory nerves for saliva (§ 145) and those for sweating (§ 289, II.). It is to be remembered, however, that these fibres not unfrequently lie in the same sheath with other nerve-fibres, so that stimulation of a nerve may give rise to several results, according to the kind of nerve-fibres present in the nerve. Thus, the secretory and vaso-motor nerves of glands may be excited simultaneously.

(c.) **Trophic.**—The end-organs of these nerve-fibres lie in the tissues themselves, and are as yet unknown. These nerves are called trophic, because they are supposed to govern or control the normal metabolism of the tissues.

Trophic Influence of Nerves.—The trophic functions of certain nerves are referred to as under:—On the influence of the trigeminus on the eye; on the mucous membrane of the mouth and nose; on the face (§ 347); on the influence of the vagus on the lungs (§ 352); motor nerves on muscle (§ 307); certain central organs upon certain viscera (§ 379).

Growth of Bones.—Section of certain nerves influences the *growth of the bones*. H. Nasse found that, after section of their nerves, the bones showed an absolute diminution of all their individual constituents, while there was an increase of the fat. Section of the spermatic nerve is followed by degeneration of the testicle (Nélaton, Obolensky). After extirpation of their secretory nerves, there is degeneration of the sub-maxillary glands (p. 288). Section of the nerves of the cock's-comb interferes with the nutrition of that organ (Legros, Schiff). Section of the cervical sympathetic nerve in *young, growing* animals is followed by a more rapid growth of the ear upon that side (Bidder, Stirling, Stricker), also of the hair on that side (Schiff, Stirling, Sig. Meyer); while it is said that the corresponding half of the brain is smaller, which, perhaps, is due to the pressure from the dilated blood-vessels (Brown-Séguard).

Blood-vessels.—Lewaschow found that, continued uninterrupted stimulation of the sciatic nerve of dogs, by means of chemical stimuli, [threads dipped in sulphuric acid], caused hypertrophy of the lower limb and foot, together with the formation of aneurismal dilatations upon the blood-vessels.

Skin and Cutaneous Appendages.—In man, stimulation or paralysis of nerves, or degeneration of the grey matter of the spinal cord (Jarisch), is not unfrequently followed by changes in the pigmentation of the skin, in the nails, in the hair and its mode of growth and colour. [Injury to the brain, as by a fall, sometimes results in paralysis of the hair follicles, so that, after such an injury, the hair is lost over nearly the whole of the body]. Sometimes there may be eruptions upon the skin apparently traumatic in their origin (v. Bärensprung, Lélouir). Sometimes, there is a tendency to decubitus (§ 379), and in some rare cases of tabes, there is a peculiar degeneration of the joints (Charcot's disease). The changes which take place in a nerve separated from its centre are described in § 325.

Trophoneuroses.—Some of the chief data on which the existence of trophic nerves is assumed are indicated above. There are many pathological conditions referable to diseases or injuries of nerves.]

Muscles.—As is well known, paralysis of a motor nerve leads to simple atrophy of the corresponding muscle, provided it be not exercised; but when the motor ganglionic cells of the anterior horn of the grey matter, or the corresponding cells in the crus, pons, and medulla, are paralysed, there is an active condition of atrophy with proliferation of the muscular nuclei. *Progressive muscular atrophy*, or wasting palsy, is another trophic change in muscle, whereby either individual muscles or groups of muscles are one after the other paralysed and become atrophied. In *pseudo-hypertrophic paralysis*, there is cirrhosis or increased development of the connective-tissue, with a diminution of the true muscular elements, so that although the muscles increase in bulk, their power is diminished.]

Cutaneous Trophic Affections.—Amongst these may be mentioned the occurrence of red patches or erythema, urticaria or nettle-rash, some forms of lichen, eczema, the bullæ or blebs of pemphigus, and some forms of ichthyosis, each of which may occur in limited areas after injury to a nerve, or its spinal or cerebral centre. The relation between the eruption and the distribution of a nerve is sometimes very marked in *herpes zoster*, which frequently follows the distribution of the intercostal and supraorbital nerves. *Glossy skin* (Paget, Weir Mitchell) is a condition depending upon impaired nutrition and circulation, and due to injuries of nerves. The skin is smooth and glossy in the area of distribution of certain nerves, while the wrinkles and folds have disappeared. In *myxœdema*, the subcutaneous tissue and other organs are infiltrated with, while the blood contains *muçin*. The subcutaneous tissue is swollen, and the patient (adult woman) looks as if suffering from renal dropsy. There is marked alteration of the cerebral faculties, and a condition resembling a "cretinoid state," occurs

after the excision of the thyroid gland. Victor Horsley has shown that a similar condition occurs in monkeys after excision of the thyroid gland.]

[Laycock described a condition of *nervous œdema*, which occurs in some cases of hemiplegia, and apparently it is independent of renal or cardiac disease.]

[There are alterations in the *colour* of the skin depending on nervous affections, including localised *leucoderma*, where circumscribed patches of the skin are devoid of pigment. The pigmentation of the skin in *Addison's disease* or *bronzed skin*, which occurs in some cases of disease of the suprarenal capsules, may be partly nervous in its origin, more especially when we consider the remarkable pigmentation that occurs around the nipple and some other parts of the body during pregnancy, and in some uterine and ovarian affections (Laycock).]

[In *anæsthetic leprosy*, the anæsthesia is due to disease of the nervous structure, which results in disturbances of motion and nutrition. Amongst other remarkable changes in the skin, perhaps due to trophic conditions, are those of symmetrical and local *gangrene*, and *acute decubitus* or bed-sores].

[**Bed-sores.**—Besides the simple chronic form, which results from over-pressure, bad nursing, and inattention to cleanliness, combined with some defect of the nervous conditions, there is another form, *acute decubitus*, which is due directly to nerve influence (Charcot). The latter usually appears within a few hours or days of the cerebral or spinal lesion, and the whole cycle of changes—from the appearance of the erythematous dusky patch to inflammation, ulceration, and gangrene of the buttock—are completed in a few days. An acute bed-sore may form when every attention is paid to the avoidance of pressure and other unfavourable conditions. When it depends on cerebral affections it begins and develops rapidly in the centre of the gluteal region on the paralysed side, but when it is due to disease of the spinal cord, it forms more in the middle line in the sacral region; while in unilateral spinal lesions, it occurs not on the paralysed, but on the anæsthetic side, a fact which seems to show that the trophic, like the sensory fibres, decussate in the cord (Ross).]

[There are other forms due to nervous disease, including symmetrical gangrene, and local asphyxia of the terminal parts of the body, such as the toes, nose, and external ear, caused perhaps by spasm of the small arterioles (Raynaud); and the still more curious condition of *perforating ulcer of the foot*.]

[Hæmorrhage of nervous origin sometimes occurs in the skin, including those that occur in locomotor ataxia after severe attacks of pain, and *hematoma aurium*, or the insane ear, which is specially common in general paralytics.]

(d.) **Inhibitory nerves** are those nerves which modify, inhibit, or suppress a motor or secretory act already in progress.

Take as an example, the effect of the vagus upon the action of the heart. Stimulation of the peripheral end of the vagus causes the heart to stand still in diastole (§ 85); the effect of the splanchnic upon the intestinal movements (§ 161). The vaso-dilator nerves, or those whose stimulation is followed by dilatation of the blood-vessels of the area which they supply, are referred to specially in § 237.

II. Centripetal or Afferent Nerves.

(a.) **Sensory Nerves**—(sensory in the narrower sense), which by means of special end-organs conduct sensory impulses to the central nervous system.

(b.) **Nerves of Special Sense.**

(c.) **Reflex or Excito-motor Nerves.**—When the periphery of one of these nerves is stimulated, an impulse is set up which is conducted by

them to a nerve-centre, from whence it is transferred to a *centrifugal* or *efferent* fibre, and the mechanism (I, a, b, c, d) in connection with the peripheral end of this efferent fibre is set in action; thus there are—*Reflex motor*, *Reflex secretory*, and *Reflex inhibitory* fibres.

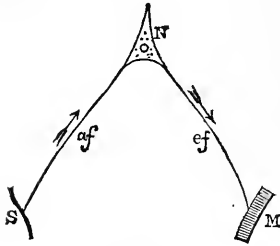

Fig. 317.

Scheme of a reflex motor act—
S, skin; *af*, afferent nerve;
N, nerve-cell; *ef*, efferent
fibre; M, muscle.

[Fig. 317 shows the simplest mechanism necessary for a reflex motor act. The impulse starts from the skin, S, travels up the nerve, *af*, to the nerve-centre or nerve-cell, N, situate in the spinal cord, where it is modified and transferred to the outgoing fibre, *ef*, and conveyed by it to the muscle, M.]

III. Intercentral Nerves.

These fibres serve to connect ganglionic centres with each other, as, for example, in co-ordinated movements, and in extensive reflex acts.

The Cranial Nerves.

343. I. Nervus Olfactorius.

Anatomical.—The three-sided, prismatic, *tractus olfactorius* lying in a groove on the under surface of the frontal lobe, arises by means of an inner, outer, and upper root, from the tuber olfactorium (Fig. 321, I). The tractus swells out upon the cribriform plate of the ethmoid bone, and becomes the *bulbus olfactorius*, which is the analogue of the special portion of the brain existing in different mammals with a well-developed sense of smell (Gratiolet). From twelve to fifteen olfactory filaments pass through the foramina in the cribriform plate of the ethmoid bone. At first, they lie between the periosteum and the mucous membrane, but in the lower third of their course, they enter the mucous membrane of the regio olfactoria. The bulb consists of white matter below, and above of grey matter mixed with small spindle-shaped ganglionic cells. Henle describes six, and Meynert eight layers, of nervous matter seen on transverse section.

Function.—It is the only *nerve of smell*. Physiologically, it is excited only by gaseous odorous bodies—(see *Sense of Smell*, § 420). Stimulation of the nerve, by any other form of stimulus, in any part of its course, causes a sensation of smell. Congenital absence or section of both olfactory nerves abolishes the sense of smell (easily performed on young animals—Biffi).

Pathological.—The term *Hyperosmia* is applied to cases where the sense of smell is excessively and abnormally acute, as in some hysterical persons, and in cases where there is a purely subjective sense of smell, as in some insane persons. The latter is perhaps due to an abnormal stimulation of the cortical centre (§ 378, IV.). *Hyposmia* and *Anosmia* (i.e., diminution and abolition of the sense of smell) may be due to mechanical causes, or to over-stimulation. Strychnin sometimes increases, while morphia diminishes, the sense of smell.

344. II. Nervus Opticus.

Anatomical.—The **tractus opticus** (Fig. 321, II) arises by a number of fibres from the inner grey substance of the thalamus opticus, and the anterior corpora quadrigemina; other fibres cover these structures in the form of a thin plate of nervous matter. The corpora geniculata (Fig. 321, *i, e*) form ganglia, intercalated, as it were, in the course of certain of the fibres. Another set of fibres, quite distinct from the foregoing, passes between the bundles of the crus cerebri, and reaches the multicellular nucleus within the tegmentum of the crus (corpus subthalamicum). Other fibres are said to pass to the spinal cord, directly through the medulla oblongata, without the intervention of any grey matter. They are said by Stilling to reach as far as the decussation of the pyramids. According to this view, the optic nerve has a spinal root, which explains the relation of stimulation of the retina to the dilator of the iris.

A broad bundle of fibres passes from the origin of the optic tract to the *cortical psycho-optic centre*, at the apex of the occipital lobe (Wernicke—§ 379, IV.).

The **Optic Tract** bends round the pedunculus cerebri, where it unites with its fellow of the opposite side to form the *chiasma*.

[Connections of Optic Tract.—There is very considerable difficulty in ascertaining the exact origin of all the fibres of the optic tract. Although as yet the statement of Gratiolet is not proved that the optic tract is directly connected with every part of the cerebral hemisphere in man, from the frontal to the occipital lobe, still the researches of D. J. Hamilton have shown that its connections are very extensive. It is certain that some of them are *ganglionic*—i.e., connected with the ganglia at the base of the brain, while others are *cortical*, and form connections with the cortex cerebri. The *ganglionic* fibres arise from the corpora geniculata, pulvinar, and anterior corpora quadrigemina, and probably also from the substance of the thalamus. The *cortical* fibres join the ganglionic to form the optic tract. According to D. J. Hamilton, the connection with the cortex in the *frontal* region is brought about by “Meynert’s commissure.” The latter arises directly from the lenticular-nucleus-loop, decussates in the lamina cinerea, and passes into the optic nerve of the opposite side. The lenticular-nucleus-loop is formed below the lenticular nucleus by the junction of the striæ medullares; the striæ medullares form part of the fibres of the internal capsule, and the inner capsule is largely composed of fibres descending from the cortex. Hamilton also asserts that other cortical connections join the tract as it winds round the pedunculus cerebri, and they include (*a*) a large mass of fibres coming from the motor areas of the opposite cerebral hemisphere, crossing in the corpus callosum, entering the outer capsule, and joining the tract directly; (*b*) fibres uniting it to the tempero-sphenoidal lobe of the same side, especially the first and second tempero-sphenoidal convolutions; (*c*) fibres to the gyrus hippocampi of the same side; (*d*) a large leash of fibres forming the “*optic radiation*” of Gratiolet, which connect it directly with the tip of the occipital lobe. There are probably also *indirect* connections with the occipital region through some of the basal ganglia. Although some observers do not admit the connections with the frontal

and sphenoidal lobes, all are agreed as to its connection with the occipital by means of the "optic radiation."]

[The **Optic Radiation** of Gratiolet is a wide strand of fibres expanding and terminating in the occipital lobes. It is composed of, or stated otherwise, gives branches to (a) the optic tract directly, (b) the corpus geniculatum internum and externum, (c) to the pulvinar and substance of the thalamus, (d) a direct sensitive band (Meynert's "Sensitive band") to the posterior third of the posterior limb of the inner capsule, (e) fibres which run between the Island of Reil and the tip of the occipital lobe (D. J. Hamilton).]

Chiasma.—The extent of the decussation of the optic fibres in the chiasma is subject to variations. As a rule, half of the fibres of one

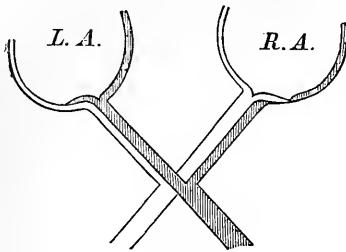

Fig. 318.

Scheme of the semi-decussation of the optic nerves—*L.A.*, left eye; *R.A.*, right eye.

tract cross to the optic nerve of the opposite side (Fig. 318), so that the left optic tract sends fibres to the left half of both eyes, while the right tract supplies the right half of both eyes (§ 378, IV.).

Hence, in man, the destruction of one optic tract (and its central continuation in the occipital lobe of the cerebrum) produces "*equilateral* or *homonymus hemiopia*." In the dog and cat there is a semi-decussation; hence, in these animals extirpation of one eyeball causes atrophy and degeneration of half of the nerve-fibres in both optic

tracts (Gudden). Baumgarten and Mohr have observed a similar result in man. A sagittal section of the chiasma in the cat produces partial blindness of both eyes (Nicati). According to Gudden, the fibres which decussate are more numerous than those which do not, although J. Stilling maintains that they are only slightly more numerous. According to J. Stilling the decussating fibres lie in the central axis of the nerve, while those which do not decussate form a layer around the former.

Other observers maintain that there is complete decussation of all the fibres in the chiasma. Hence, *section of one optic nerve* causes dilatation of the pupil and blindness on the *same* side, while *section of one optic tract* causes dilatation of the pupil and blindness of the *opposite* eye (Knoll, Brown-Séguard, Mandelstamm). In osseous fishes, both optic nerves are isolated and merely cross over each other, while in the cyclostomata they do not cross at all.

Injury of the external geniculate body and section of the anterior brachium have the same effect as section of the optic tract of the *same* side (§ 359—Bechterew).

In very rare cases, the decussation is absent in man, so that the right tract passes directly into the right eyeball, and the left into the left eyeball (Vesalius, Caldani, Lösel), the sight not being interfered with (Vesalius).

It is quite certain that the individual fibres do not divide in the chiasma. Two commissures, the inferior commissure (Gudden) and Meynert's commissure, unite both optic tracts further back.

[Hemiopia and Hemianopsia.—When one optic tract is interfered with or divided, there is interference with or loss of sight in the lateral halves of both retinae, the blind part being separated from the other half of the field of vision by a vertical line. When it is spoken of as paralysis of one-half of the retina, the term *hemiopia* is applied to it; when, with reference to the field of vision, the term *hemianopsia* is used (see *Eye*). Suppose the *left* optic tract to be divided or

pressed upon by a tumour at K, Fig. 319, then the outer half of the left and the inner half of the right eye are blind, causing *right lateral hemianopsia*, i.e., the two halves are affected which correspond in ordinary vision, so that the condition

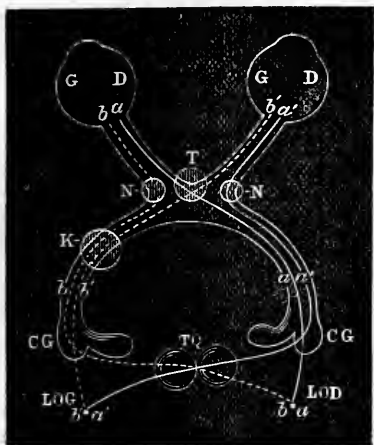

Fig. 319.

Diagram of the decussation of the optic tracts — T, semi-decussation in the chiasma; T Q, decussation of fibres behind the external geniculate bodies (CQ); *a'b*, fibres which do not decussate in the chiasma; *b'a'*, fibres proceeding from the right eye and coming together in the left hemisphere (L O G); L O G, K, lesion of the left optic tract producing right lateral hemianopsia; A, lesion in the left hemisphere producing crossed amblyopia (right eye); T, lesion producing temporal hemianopsia: N N, lesion producing nasal hemianopsia (Knott). After Charcot.

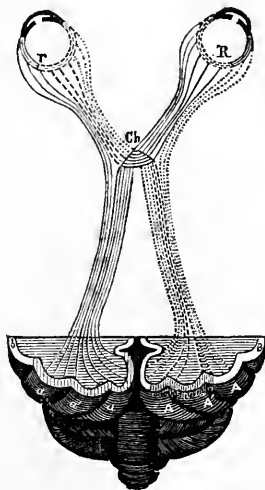

Fig. 320.

Horizontal section of the visual cortical centres and eyeballs (H. Munk).

is spoken of as *homonymous hemianopsia*. Suppose the lesion to be at T, Fig. 319, then there is paralysis of the *inner halves* of *both eyes*, causing *double temporal hemianopsia*. When there are two lesions at N N, which is very rare, the *outer halves* of both retinae are paralysed, so that there is *double nasal hemianopsia*. In order to explain some of the eye symptoms that occasionally occur in cerebral disease, Charcot has supposed that some of the fibres which pass from the external geniculate body to the visual centres in the occipital lobe cross behind the corpora quadrigemina, and this is represented in the diagram as occurring at T Q, in the corpora quadrigemina. On this view, all the occipital cortical fibres from one eye would ultimately pass to the cortex of the occipital lobe of the opposite hemisphere. This view, however, by no means explains all the facts, for in cases of homonymous hemianopsia the point of central vision on both sides, i.e., both maculae luteae are always unaffected, so that it is assumed that each macula lutea is connected with both hemispheres.]

[Munk's View.—Fig. 320 illustrates H. Munk's view. He thinks that there

are three areas in the retina corresponding to three cortical visual spheres, or parts of the visual centre in the occipital lobe (dog), the external part of the right eye, R, being connected with the external part, A, while the central and internal parts of the same eye decussate and are connected with the corresponding parts, *a' a*, of the cortical visual centre of the opposite occipital lobe (Ross)].

The two outer, upper, or lower halves of the retina have been observed to be blind in disease of the optic tract in man, which, of course, indicates some other mode of arrangement of the nerve-fibres.

Function.—The optic nerve is the nerve of sight; physiologically, it is excited only by the transference of the vibrations of the ether to the rods and cones of the retina (see *Sense of Sight*). Every other form of stimulus, when applied to the nerve in its course or at its centre, causes the sensation of light. Section or degeneration of the nerve is followed by blindness. Stimulation of the optic nerve causes a reflex contraction of the pupils, the efferent nerve being the oculomotorius or third cranial nerve. If the stimulus be very strong, the eyelids are closed and there is a secretion of tears.

The influence of light upon the general metabolism is stated at p. 259.

As the optic nerve has special and independent connections with the so-called psycho-optic centre (§ 378, IV), as well as with the centre for narrowing the pupil (§ 345), it is evident that, under pathological circumstances, there may be, on the one hand, blindness with retention of the action of the iris, and on the other loss of the movements of the iris, the sense of vision being retained (Wernicke).

Pathological.—Stimulation of almost the whole of the nervous apparatus may cause excessive sensibility of the visual apparatus (*hyperæsthesia optica*), or even visual impressions of the most varied kinds (*photopsia*, *chromatopsia*), which in cases of stimulation of the psycho-optic centre may become actual visual hallucinations (§ 378, IV.). Material change in, and inflammation of the nervous apparatus are often followed by a nervous weakness of vision (*amblyopia*), or even by blindness (*amaurosis*). Both conditions, however, may be the signs of disturbances of other organs, *i.e.*, they are “sympathetic” signs, due it may be to changes in the movement of the blood-stream, depending upon stimulation of the vaso-motor nerves. The discovery of the partial origin of the optic nerve from the spinal cord explains the occurrence of amblyopia (with partial atrophy of the optic nerve) in disease of the spinal cord, especially in tabes.

Hemeralopia and Nyctalopia.—Many *poisons*, such as lead and alcohol, disturb vision. There are remarkable intermittent forms of amaurosis known as day-blindness (*hemeralopia*), which occurs in some diseases of the liver [and is sometimes associated with incipient cataract. The person can see better in a dim light than during the day or in a bright light. In night-blindness (*nyctalopia*), the person cannot see at night or in a dim light, while vision is good during the day or in a bright light. It depends upon disorder of the eye itself, and is usually associated with imperfect conditions of nutrition].

345. III. Nervus Oculomotorius.

Anatomical.—It springs from the oculomotorius nucleus (united with that of the trochlearis), which is a direct continuation of the anterior horn of the spinal cord, and lies under the aqueduct of Sylvius (Fig. 321).

The origin is connected with the corpora quadrigemina, to which the intraocular fibres may be traced, and also with the lenticular nucleus through the pedunculus cerebri. Beyond the pons, it appears on the inner side of the pedunculus between the superior cerebellar and posterior cerebral arteries (Fig. 321, III).

Function.—It contains: 1. The voluntary motor fibres for all the external muscles of the eyeballs—except the external rectus and superior oblique—and for the levator palpebræ superioris. The co-ordination of the movements of both eyeballs, however, is independent of the will. 2. The fibres for the *sphincter pupillæ*, which are excited reflexly from the retina. 3. The voluntary fibres for the *muscle of accommodation*, the tensor choroideæ or ciliary muscle. The intrabulbar fibres of 2 and 3 proceed from the branch for the inferior oblique muscle, as the short root of the ciliary ganglion (Fig. 322). They reach the eyeball through the short ciliary nerves of the ganglion. v. Trautvetter, Adamük, Hensen, and Völckers observed that, stimulation of the nerve caused changes in the eye similar to those which accompany near vision. The three centres for the muscle of accommodation, the sphincter pupillæ and the internal rectus muscle, lie directly in relation with each other, in the most posterior part of the floor of the third ventricle (Hensen and Völckers).

The *reflex* stimulation of the fibres of the sphincter of the pupil by light, perhaps also takes place in a special centre within the medulla oblongata (Meynert, Stilling). The narrowing of the pupil, which accompanies the act of accommodation for a near object, is to be regarded as an associated movement (§ 392, 5).

Anastomoses.—In man, the nerve anastomoses on the sinus cavernosus, with the ophthalmic branch of the trigeminus, whereby it receives *sensory fibres for the muscles* to which it is distributed (Valentin, Adamük), with the sympathetic through the carotid plexus, and (?) indirectly through the abducens, whereby it receives vaso-motor fibres (?).

Atropin paralyses the intrabulbar fibres of the oculomotorius, while **Calabar bean** stimulates them (or paralyses the sympathetic, or both—compare § 392).

Stimulation of the nerve, which causes contraction of the pupil, is best demonstrated on the decapitated and opened head of a bird. The pupil is *dilated* in paralysis of the oculomotorius, in asphyxia, sudden cerebral anæmia (e.g., by ligature of the carotids, or beheading), sudden venous congestion, and at death.

Pathological.—*Complete paralysis* of the oculomotorius is followed by—1, Drooping of the upper eyelid (*Ptosis paralytica*); 2, immobility of the eyeball; 3, squinting (strabismus) outwards and downwards, and consequently there is double vision (*diplopia*); 4, slight protrusion of the eyeball, because the action of the superior oblique muscle in pulling the eyeball forward is no longer compensated by the action of three paralysed recti muscles. In animals provided with a retractor bulbi muscle, the protrusion of the eyeball is more pronounced; 5, moderate dilatation of the pupil (*mydriasis paralytica*); 6, the pupil does not

contract to light; 7, inability to accommodate for a near object. It is to be noted, however, that the paralysis may be confined to individual branches of the nerve—*i.e.*, there may be incomplete paralysis.

Stimulation of the branch supplying the levator palpebræ in man causes *lagophthalmus spasticus*, while stimulation of the other motor fibres causes a corresponding strabismus spasticus. This latter form of squinting may be caused also reflexly—*e.g.*, in teething, or in cases of diarrhœa in children; [the presence of worms or other source of irritation in the intestines of children is a frequent cause of squinting.] Clonic spasms occur in *both* eyes, and also as involuntary movements of the eyeballs constituting *nystagmus*, which may be produced by stimulation of the corpora quadrigemina, as well as by other means. Tonic contraction of the sphincter pupillæ is called *myosis spastica*, and clonic contraction, *hippus*. Spasm of the muscle of accommodation (ciliary muscle) is sometimes observed; owing to the imperfect judgment of distance, this condition is not unfrequently associated with macropia.

346. IV. Nervus Trochlearis.

Anatomical.—It arises close to the oculomotorius from the *trochlearis-nucleus*, which is to a certain extent a continuation of the anterior horn of the spinal cord. It passes to the lower margin of the corpora quadrigemina, pierces the roof of the aqueduct of Sylvius, and after decussating with the root of the opposite side (Schröder van der Kolk), it pierces the crus at the superior and external border (Fig. 321, IV.). It has also an origin from the locus cœruleus. The root of the nerve receives some fibres from the nucleus of the abducens of the opposite side.

Function.—It is the voluntary motor nerve of the superior oblique muscle. (In co-ordinated movements, however, it is involuntary.)

Anastomoses.—Its connections with the plexus caroticus sympathici and with the first branch of the trigeminus have the same significance as similar branches of the oculomotorius.

Pathological.—*Paralysis* of the trochlearis nerve causes a very slight loss of the mobility of the eyeball outwards and downwards. There is slight squinting inwards and upwards, with diplopia or double vision. The images are placed obliquely over each other; they approach each other when the head is turned towards the sound side, and are separated when the head is turned towards the other side. The patient at first directs his head forwards, later he rotates it round a vertical axis towards the sound side. In rotating his head, (whereby the *sound* eye may retain the primary position), the eye rotates with it. *Spasm* of the trochlearis causes squinting outwards and downwards.

347. V. Nervus Trigeminus.

Anatomical.—The trigeminus (Fig. 322, 5), arises like a spinal nerve by two roots (Fig. 321, V). The smaller, *anterior, motor* root proceeds from the "*motor trigeminal nucleus*" which is provided with many multipolar nerve-cells, and lies in the floor of the medulla oblongata, not far from the middle line. Fibres connect this nucleus with the opposite side of the cerebrum. The large, *posterior, sensory* root receives fibres:—1, From the small cells of the "*sensory trigeminal nucleus*" which lies at the level of the pons, and is the analogue of the posterior horn of the grey matter of the spinal cord. 2, From the grey matter of the posterior horn of the spinal cord downwards as far as the middle of the cervical

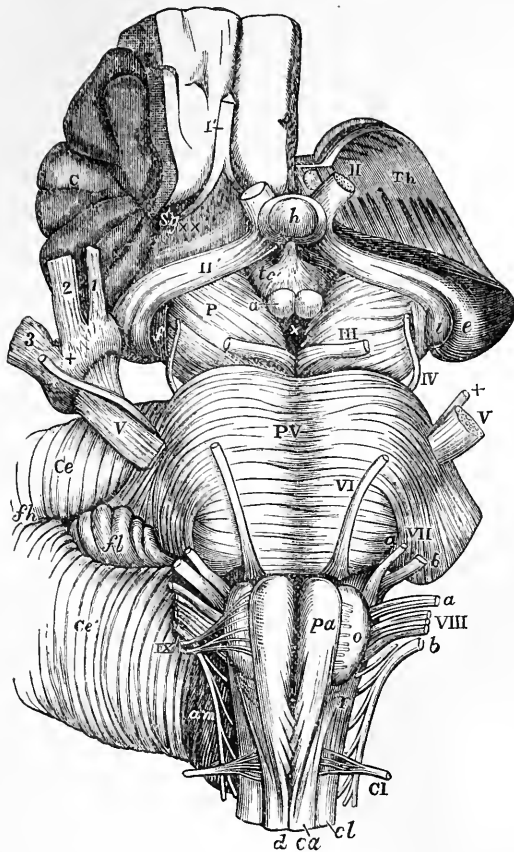

Fig. 321.

Under surface of part of the brain, showing the origins of the cranial nerves; on the right side the convolutions of the island of Reil, while on the left they have been removed—I, The olfactory tract cut short; II, left optic nerve in front of the chiasma; II', right optic tract; T h, cut surface of the left optic thalamus; C, central lobe, or island of Reil; S y, fissure of Sylvius; X X, the locus perforatus anticus; e, the external, and i, the internal, corpus geniculatum; b, hypophysis cerebri, or pituitary body; t c, tuber cinereum, with the infundibulum; a, points by a short line to one of the corpora albicantia; P, the cerebral peduncle or crns; f, the fillet; III, close to the left oculo-motor nerve; X, the locus perforatus posticus; P V, pons Varolii; V, the greater part of the fifth nerve; +, the lesser root (on the right side this mark is placed on the Gasserian ganglion and points to the lesser root, where it proceeds to join the inferior maxillary nerve); l, ophthalmic division of the fifth nerve; VII a, the facial; VII b, the auditory; VIII, the vagus; VIII a, the glosso-pharyngeal; VIII b, the spinal accessory nerve; IX, the hypoglossal nerve; fl, the flocculus; f h, the horizontal fissure of the cerebellum (Ce); a m, the amygdala; p a, the anterior pyramid; o, olivary body; e, the restiform body; d, the anterior median fissure of the spinal cord; cl, the lateral column of the spinal cord; CI, the sub-occipital or first cervical nerve.

region. These fibres run into the posterior column of the cord and ascend into the trigeminus. 3, The "*trophic root*" (Merkel) arises from a mass of cells at the side of the aqueduct of Sylvius. 4, Another root comes from the upper part of the floor of the medulla oblongata, from the substantia ferruginosa under the locus cœruleus. These fibres decussate. 5, Some fibres proceed from the crus of the pedunculus cerebri. 6, Some fibres come from the cerebellum, through the crura cerebelli. The origins of the sensory root anastomose with the motor nuclei of all the nerves arising from the medulla oblongata, with the exception of the abducens. This explains the vast number of *reflex relations* of the fifth nerve. The thick trunk appears on each side of the pons (Fig. 321), when its posterior root (perhaps in conjunction with some fibres from the anterior), forms the *Gasserian ganglion*, upon the tip of the petrous part of the temporal bone (Fig. 322). Fibres from the sympathetic proceed from the plexus cavernosus to the ganglion. The nerve divides into *three* large branches.

I. The ophthalmic branch (Fig. 322, *d*), receives *sympathetic* fibres (*vaso-motor nerves*) from the plexus cavernosus; it passes through the superior orbital fissure [sphenoidal] into the orbit. Its *branches* are :—

1. The small recurrent nerve which gives *sensory* branches to the tentorium cerebelli. Fibres proceed along with it from the carotid plexus of the sympathetic, which are the *vaso-motor* nerves for the dura mater.

2. The lachrymal nerve gives off—(*a*) *Sensory* branches to the conjunctiva, the upper eyelid, and the neighbouring part of the skin over the temple (Fig. 322, *a*); (*b*) true *secretory* fibres to the lachrymal gland(?). Stimulation of this nerve is said to cause a secretion of tears, while its section prevents the reflex secretion excited through the sensory nerves of the eye. After a time, section of the nerve is followed by a paralytic secretion of tears (Herzenstein and Wolferz, Demtschenko), although the statement is contested by Reich. The secretion of tears may be excited reflexly by strong stimulation of the retina by light by stimulation of the first and second branches of the trigeminus, and through all the sensory cranial nerves (Demtschenko) (§ 356, A, 6).

3. The frontal (*f*) gives off the supra-trochlear, which supplies *sensory* fibres to the upper eyelids, brow, glabella, and those which excite the secretion of tears reflexly; and by its supra-orbital branch (*b*), analogous branches to the upper eyelid, skin of the forehead, and the adjoining skin over the temple as far as the vertex.

4. The naso-ciliary nerve (*n, c*), by its infra-trochlear branch supplies fibres similar to those of 3, to the conjunctiva, caruncula and saccus lacrimalis, the upper eyelid, brow, and root of the nose. Its ethmoidal branch supplies the tip and alæ of the nose, outside and inside, with sensory branches, as well as the upper part of the septum and the turbinated bones with *sensory* fibres, which can act as afferent nerves in the reflex secretion of tears; while it is probable that *vaso-motor*

fibres are supplied to these parts through the same channel. (These fibres may be derived from the anastomosis with the sympathetic (?). The naso-ciliary nerve gives off the long root (*l*) of the ciliary ganglion (*c*), and 1–3 long ciliary nerves.

The **ciliary ganglion** (Fig. 322, *c*—which, according to Schwalbe, perhaps belongs rather to the third than the fifth nerve), has *three* roots—(*a*) the *short* or oculomotorius (3—see p. 789); (*b*) the *long* (*l*), from the naso-ciliary; and (*c*) the *sympathetic* (*s*), sometimes united with *b*, from the carotid plexus. The *short ciliary nerves* (*t*), 6–10 in number, proceed from the ganglion, along with the long ciliary nerves to near the entrance of the optic nerve, where they perforate the sclerotic coat and run forwards between it and the choroid.

Ciliary Nerves.—*Physiologically*, these nerves (in addition to those mentioned at p. 789, 2, 3, from the oculomotorius) contain the following kinds of nerve-fibres:—

1. **Sensory fibres** for the *cornea* (Bochdalek), which are distributed as excessively fine fibrils between the epithelium of the *conjunctiva bulbi*; they perforate the sclerotic (Giraldès). These fibres cause a reflex secretion of tears (N. lacrimalis), and closure of the eyelids (N. facialis). Sensory fibres are supplied to the *iris* (pain in iritis and in operations on the iris), the *choroid* (painful tension when the ciliary muscle is strained), and the *sclerotic*.

2. **Vaso-motor nerves** for the blood-vessels of the iris, choroid, and retina. They arise in part from the *sympathetic* root, and the anastomosis of the sympathetic with the ophthalmic division of the trigeminus (Wegner). The *iris* receives most of its vaso-motor nerves from the trigeminus itself (Rogow), and few from the sympathetic. The blood-vessels of the retina are supplied chiefly from the sympathetic, and, according to Klein and Svetlin, they are not influenced either by stimulation or division of the sympathetic.

Schwalbe supposes that the fibres which spring directly from the nerve-cells of the ciliary ganglion are vaso-motor in their function.

3. **Motor fibres** for the dilator pupillæ, which for the most part are derived from the *sympathetic* (Petit, 1727), through the sympathetic root of the ganglion, and the anastomosis of the sympathetic with the trigeminus (Balogh, Oehl). The ophthalmic division contains independent fibres for the dilatation of the pupil (Schiff), which arise in the medulla oblongata and proceed directly into the ophthalmic (? or arise from the Gasserian ganglion—Oehl).

It is not conclusively determined whether dilator fibres also proceed through the sympathetic root of the ciliary ganglion, and reach the iris through the ciliary nerves. In the dog, these fibres do not pass through the ciliary ganglion, but go directly along the optic nerve to the eye (Hensen and Völckers).



Fig. 322.

Semi-diagrammatic representation of the nerves of the eyeball, the connections of the trigeminus and its ganglia, together with the facial and glosso-pharyngeal nerves—3, Branch to the inferior oblique muscle from the oculomotorius, with the thick short root, to the ciliary ganglion (*c*); *t*, ciliary nerves; *l*, long root to the ganglion from the naso-ciliary (*nc*); *s*, sympathetic root from sympathetic plexus (*Sy*) surrounding the internal carotid (*G*); *d*, first or ophthalmic division of the trigeminus (5), with the naso-ciliary (*nc*), and the terminal branches of the lachrymal (*a*), supra-orbital (*b*), and frontal (*f*); *e*, second or superior maxillary division of the trigeminus; *R*, infra-orbital; *n*, sphenopalatine (Meckel's) ganglion with its roots; *j*, from the facial, and *v*, from the sympathetic; *N*, the nasal branches, and *pp1*, the palatine branches of the ganglion; *g*, third or inferior maxillary division of the trigeminus; *k*, lingual; *ii*, chorda tympani; *m*, otic ganglion, with the roots from the tympanic plexus, the carotid plexus, and from the 3rd branch, and with its branches to the auriculo-temporal (*A*), and to the chorda (*ii*); *L*, sub-maxillary ganglion with its roots from the tympanico-lingual, and the sympathetic plexus on the external maxillary artery (*q*). 7. Facial nerve—*j*, its great superficial petrosal branch; α , gang. geniculatum; β , branch to the tympanic plexus; γ , branch to the stapedius; δ , anastomatic twig to the auricular branch of the vagus; *ii*, chorda tympani; *S*, stylo-mastoid foramen. 9. Glosso-pharyngeal— λ , its tympanic branch; τ and ϵ , connections with the facial; *U*, terminations of the gustatory fibres of 9 in the circumvallate papillae; *Sy*, sympathetic with *Gg*, *s*, the superior cervical ganglion; *I*, *II*, *III*, *IV*, the four upper cervical nerves; *P*, parotid, *M*, sub-maxillary gland.

After section of the trigeminus, the pupil becomes contracted (rabbit and frog), but this effect is not permanent. After excision of the superior cervical ganglion of the sympathetic, the power of dilatation of the pupil is not completely abolished. The narrowing of the pupil which follows section of the trigeminus in the rabbit, and which rarely lasts more than half an hour, may be regarded as due to a reflex stimulation of the oculomotorius fibres of the sphincter, in consequence of the painful stimulation caused by section of the trigeminus.

With regard to the *centre* for 2 and 3 see § 367, 8.

Effects of Stimulation of the Sympathetic.—Either in the neck, or in its course to the eye, when the peripheral end of the cervical sympathetic is stimulated, besides other effects on the blood-vessels, there is *dilatation of the pupil*, as well as contraction of the *smooth muscular fibres* in the orbit and eyelids. The *membrana orbitalis*, which separates the orbit from the temporal fossa in animals, contains numerous smooth muscular fibres (*musculus orbitalis*). The corresponding membrane of the inferior orbital fissure [sphenomaxillary fissure] in man has a layer of smooth muscle, one millimetre thick, and arranged for the most part longitudinally. Both *eyelids* contain smooth muscular fibres which serve to close them; in the upper lid, they lie as a continuation of the levator palpebræ superioris, in the lower lid, close under the conjunctiva. *Tenon's capsule* also contains smooth muscular fibres. The sympathetic nerve supplies all these muscles (Heinr. Müller)—(the orbital muscle is partly supplied from the sphenopalatine ganglion); in animals the retractor of the third eyelid at the inner angle of the eye is similarly supplied. Hence, *stimulation of the sympathetic* causes dilatation of the pupil and of the palpebral fissure, with protrusion of the eyeball. This result may be caused reflexly by strong stimulation of sensory nerves. Strong stimulation of the nerves of the sexual organs is followed by similar phenomena in the eye. The dilatation of the pupil, which occurs in children affected with intestinal worms, is perhaps an analogous phenomenon. The pupil is dilated when the spinal cord is stimulated (at the origin of the sympathetic), as in tetanus.

Section of the Sympathetic, besides other effects, causes narrowing of the fissure between the eyelids, the eyeball sinks in its socket, (and in animals, the third eyelid is relaxed and protruded). In dogs, section causes internal squint, as the external rectus receives some motor fibres from the sympathetic (p. 804). (The origin of these fibres from the cilio-spinal region of the cord is discussed under *Spinal Cord*, § 362, 1.)

4. It is probable that **trophic fibres** occur in the trigeminus, and pass through the ciliary nerves to reach the eye. If the trigeminus be divided within the cranium, after 6–8 days, inflammation, necrosis of the cornea, and ultimately, complete destruction of the eyeball take place [*Panophthalmia*] (Fodèra, 1823, Magendie, 1824, Longet).

Merkel maintains that he has ascertained the central root of these trophic fibres, while Meissner and Büttner regard the trophic fibres as those that lie most internally in the nerve. According to Magendie and Longet, the trophic fibres for the eyeball and the mucous membrane of the mouth, appear first in the Gasserian ganglion, as, according to them, section of the trunk behind the ganglion does not produce any trophic disturbances; which, however, is denied by Schiff.

Trophic Fibres.—In weighing the evidence for and against the existence of

trophic fibres, we must bear in mind the following considerations:—1, Section of the trigeminus makes the whole eye *insensible*; the animal is therefore unconscious of direct injury to its eye, and cannot therefore remove any offending body. Dust or mucus, which may adhere to the eye, is no longer removed by the reflex closing of the eyelids; while owing to the absence of the reflex, the eye is more open and is therefore subject to more injuries, the reflex secretion of tears is also arrested. Snellen (1857) fixed the ear of a rabbit in front of its eye so as to protect the latter, and shield it from injuries, and he found that the inflammation and other events occurred at a later date, while, according to Meissner and Büttner, if the eye be protected by means of a complete capsule, the inflammation does not occur at all. There can be no doubt that the loss of the sensibility of the eye favours the occurrence of the inflammation. But Meissner, Büttner, and Schiff observed that inflammation of the eye occurred, when the *trophic* (most internal) fibres alone were divided, the eye at the same time retaining its sensibility; this would seem to indicate the existence of trophic fibres, but Cohnheim and Senftleben dispute the statement. Conversely, the sensibility of the eye may be abolished by partial section of the nerve, yet the eye does not become inflamed (Schiff). Ranvier, who denies the existence of trophic nerves, made a circular incision round the margin of the cornea through its superficial layers so as to divide all the corneal nerves. Insensibility of the cornea was thereby produced, but never keratitis. Further, in man and animals, who cannot close their eyelids, there is redness with secretion of tears, or slight dryness and opacity of the surface of the eyeball (*Xerosis*), but never the inflammation already described (Samuel). 2. We must also take into consideration the following:—Section of the trigeminus paralyzes the vaso-motor nerves in the interior of the eyeball, which must undoubtedly cause a disturbance in the intraocular circulation. According to Jesner and Grünhagen, the trigeminus also contains *vaso-dilator fibres*, whose stimulation is followed by increased flow of blood to the eye, with consecutive excretion of the fibrin-factors and increase in the amount of albumin of the aqueous humour. 3. After section of the nerve, the *intraocular tension is diminished*, (while stimulation of the nerve is followed by increase of the intraocular pressure), (Hippell, Grünhagen, Adamük). This diminution of the normal tension necessarily must alter the normal relation of the filling of the blood- and lymph-vessels, and also the movement of the fluids, upon which the normal nutrition is largely dependent. 4. W. Kühne observed that stimulation of the corneal nerves was followed by contraction of the so-called corneal-corpuscles. Very probably the movements of these corpuscles may influence the normal movement of the lymph in the canalicular system of the cornea (§ 384); these movements, however, would seem to depend upon the nervous system, so that its destruction is likely to produce disturbance of nutrition.

[There are *three* conditions on which the changes may depend; (1) mere loss of sensibility, which alone is not sufficient to explain the phenomena; (2) on vaso-motor disturbance, which is excluded by the above facts, and also by the other consideration that, if the fifth nerve be divided and the superior cervical ganglion excised simultaneously, ophthalmia does not occur, and, in fact, excision of this sympathetic ganglion may modify the results of section of the fifth (Sinitzin). Thus, we are forced to (3) the theory of trophic fibres, whose centre is the Gasserian ganglion.]

Pathological.—In cases of anæsthesia of the trigeminus in man, and more rarely, in severe irritation of this nerve, inflammation of the conjunctiva, ulceration and perforation of the cornea, and finally, panophthalmia have been observed (Charles Bell). This condition has been called **ophthalmia neuroparalytica**. Samuel found that a similar result was produced by electrical stimulation of the Gasserian ganglion in animals.

There are other affections of the eye depending upon disease of the **vaso-motor nerves**, which are quite different from the foregoing, as they never lead to

degenerative changes. Such is **ophthalmia intermittens** (due to malaria), a unilateral, intermittent, excessive filling of the blood-vessels of the eye, accompanied by the secretion of tears, photophobia, often accompanied by iritis and effusion of pus into the chambers of the eye. This condition was regarded as a vaso-neurotic affection of the ocular blood-vessels by Eulenburg and Landois. Pathological observations, as well as experiments upon animals (Mooren and Rumpf) have shown, that there is an intimate physiological connection between the vascular areas of both eyes, so that affections of the vascular area of one eye are apt to induce similar disturbances of the opposite eye. This serves to explain the fact, that inflammatory processes in the interior of one eyeball are apt to produce a similar condition in the other eye. This is the so-called "**sympathetic ophthalmia**" (Cassius, Felix, 97 A.D). Thus, stimulation of the ciliary nerves, or the fifth on *one* side, causes dilatation of the blood-vessels not only on its own side, but also on the other side as well (Jesner and Grünhagen). The pathological condition of **glaucoma simplex**, where the intraocular tension is greatly increased, is ascribed by Donders to irritation of the trigeminus. [Increased intraocular tension may be produced by irritation of the secretory fibres contained in the fifth nerve (Donders), by stimulating the nucleus of the trigeminus in the medulla oblongata (Hippell and Grünhagen), and also reflexly by irritation of the peripheral branches of the fifth, as by nicotin placed in the eye. It is possible, however, that some forms of glaucoma are produced by diminished removal of the aqueous humour from the eye.]

II. Superior Maxillary Division.

(e).—It gives off:—

1. The delicate **recurrent nerve**, a *sensory* branch to the dura mater, which accompanies the *vaso-motor* nerves, derived from the superior cervical ganglion of the sympathetic, and is distributed to the area of the middle meningeal artery.

2. The **subcutaneous malar** (*o*—or orbital) supplies by its temporal and orbital branches, *sensibility* to the lateral angle of the eye and the adjoining area of skin of the temple and the cheek. Certain fibres of the nerve are said to be the true secretory nerves for tears. Compare N. lacrimalis, p. 792, (Herzenstein and Wolferz).

3. The **dental**, anterior, posterior, and medius, and with them the anterior fibres from the infraorbital nerve, supply *sensory* fibres to the teeth in the upper jaw, (p. 794), the gum, periosteum, and the cavities of the jaw. The *vaso-motor* nerves of all these parts are supplied from the upper cervical ganglion of the sympathetic.

4. The **infraorbital** (R), after its exit from the infraorbital foramen, supplies *sensory* nerves to the lower eyelid, the bridge and sides of the nose, and the upper lip as far as the angle of the mouth. The accompanying artery receives its *vaso-motor* fibres from the superior cervical ganglion of the sympathetic. With regard to the fibres for the secretion of *sweat* which occur in it (pig) see p. 608.

The **sphenopalatine ganglion** (Meckel's—*n*) forms con-

nections with the II. division. To it pass two short *sensory* root-fibres from the II. division itself, which are called *spheno-palatine*. *Motor* fibres enter the ganglion from behind, through the large superficial petrosal branch of the facial (*j*—Bidder, Nuhn); and, lastly, grey *vaso-motor* fibres (*v*) from the sympathetic plexus on the carotid, (the deep large petrosal nerve). The motor and vaso-motor fibres form the Vidian nerve, which reaches the ganglion through the canal of the same name.

Branches of the Ganglion.—The branches proceeding from the ganglion are:—

1. The *sensory* fibres (N) which supply the roof, lateral walls, and septum of the nose (posterior and superior nasal); the terminal fibres of the *naso-palatine* pass through the canalis incisivus to the hard palate, behind the incisor teeth. The sensory inferior and posterior nasals for the lower and middle turbinated bones and both lower nasal ducts, are derived from the anterior palatine branch of the ganglion, which descends in the palato-maxillary canal. Lastly, the sensory branches for the hard (*p*) and soft palate (*p*₁), and the tonsils arise from the *posterior* palatine nerve. All the sensory fibres of the nose—(see also the *Ethmoidal nerve*) when stimulated, cause the reflex act of sneezing (p. 249). Preparatory to the act of sneezing, there is always a peculiar feeling of tickling in the nose, which is perhaps due to dilatation of the nasal blood-vessels. This dilatation is rapidly caused by cold, more especially when it is applied directly to the skin. The dilatation of the vessels is followed by an increased secretion of watery fluid from the nasal mucous membrane. Stimulation of the nasal nerves also causes a reflex secretion of *tears*, and it may also cause stand-still of the respiratory movements in the expiratory phase (Hering and Kratschmer)—(compare *Respiratory centre*, § 368).

2. The *motor* branches descend in the posterior palatine nerve through the small palatine canal, and give off (*h*) motor branches to the elevator of the soft palate and azygos uvulæ (Nuhn, Frühwald). The sensory fibres for these muscles are supplied by the trigeminus. According to Politzer, spasmodic contraction of these muscles occasionally causes crackling noises in the ears.

3. The *vaso-motor* nerves of this entire area arise from the sympathetic root, *i.e.*, from the upper cervical ganglion. (It is not proved whether they spring from the trigeminus itself—compare III., division, 3).

4. It is as yet unknown whether the *secretory* fibres for the glands of the whole palate are derived from the facial or sympathetic.

Stimulation of the Ganglion.—Feeble electrical stimulation of the exposed ganglion, causes a copious secretion of mucus and an increase of the temperature

in the nose (Prévoſt), and the ſame is true of ſtimulation of the ſuperior maxillary nerve (Jolyet). In this caſe, the reſult is due to a reflex ſtimulation of the ſenſory fibres acting through the vaſo-motor and ſecretory nerves, while direct ſtimulation of the nasal mucous membrane acts in the ſame way.

[Meckel's ganglion has been exciſed in certain caſes of neuralgia (Walſham).]

III. Inferior Maxillary.

(g).—It contains all the *motor* fibres of the fifth, along with a number of ſenſory fibres; it gives off—

1. The *recurrent* which ſprings by itſelf from the *ſenſory* root, enters the ſkull through the foramen ſpinoſum, and along with the nerve of the ſame name from the II. diſiſion, it ſupplies *ſenſory* fibres to the dura mater. Fibres proceed from it through the petroſo-ſquamoſal fiſſure to the mucous membrane of the cells of the maſtoid proceſs.

2. *Motor* fibres for the muſcles of maſtication, viz., the maſſeteric, the two deep temporal nerves, and the internal and external pterygoid nerves. The ſenſory fibres for the muſcles are ſupplied by the ſenſory fibres.

3. The buccinator is a *ſenſory* nerve for the mucous membrane of the cheek, and the angle of the mouth as far as the lips.

According to Jolyet and Laffont, it contains in addition, vaſo-motor fibres for the mucous membrane of the cheek, lower lip, and their mucous glands; but theſe fibres are probably derived from the ſympathetic.

Trophic Fibres.—As this region of the mucous membrane of the mouth ulcerates after ſection of the trigeminus, ſome have ſuppoſed that the buccinator nerve contains **trophic** fibres. But, as Rollett pointed out, ſection of the inferior maxillary nerve paralyses the muſcles of maſtication on the ſame ſide, and, hence, the teeth do not act vertically upon each other, but preſs againſt the cheek. Owing to the loſs of the ſenſibility of the mouth, food paſſes between the gum and the cheek, where it may remain attached, undergo decomposition, and perhaps chemically irritate the mucous membrane. At a later ſtage, owing to the wearing away of the teeth in an oblique manner, ulcers begin to form on the *ſound* ſide. Hence, there is no neceſſity for aſſuming the exiſtence of trophic fibres in this nerve. After ſection of the trigeminus, the nasal mucous membrane on the ſame ſide becomes red and congeſted. This is due to the fact that, duſt or mucus, not being removed from the noſe by the uſual reflex acts, remains there, irritates, and ultimately cauſes inflammation.

4. The lingual (*l*) receives at an acute angle the chorda tympani (*i i*), a branch of the facial. The lingual does not contain any motor fibres; it is the *ſenſory* and *tactile* nerve of the anterior two-thirds of the tongue, of the anterior palatine arch, the tonſil, and the floor of the mouth. Theſe, as well as all the other ſenſory fibres of the mouth, when ſtimulated, cauſe a reflex *ſecretion of ſaliva* (compare § 145). The lingual is accompanied by the *nerve of taſte* (chorda) for the tip and margins of the tongue (*i.e.*, the parts not ſupplied by the

glosso-pharyngeal). After section of the lingual nerve in man, Busch, Inzani, and Lussana found that the tactile sensibility was lost in the half of the tongue, and there was loss of taste in the anterior part [two-thirds] of the tongue. The fibres which administer to the sense of taste do not as a rule belong to the lingual itself, but are derived from the *chorda tympani*. This is fully set forth at p. 805. According to Schiff, the lingual nerve is the gustatory nerve, and some cases of Erb and Senator support this view. Such cases, however, seem to be exceptions to the general rule. The lingual nerve in the substance of the tongue is provided with small ganglia (Remak, Stirling). Schiff observed that section of the lingual (and also of the hypoglossal) caused *redness of the tongue*, so that vaso-motor fibres are present in its course. It is unknown whether these are derived from the anastomoses of the Gasserian ganglion with the sympathetic. The lingual appears to receive *vaso-dilator fibres* from the chorda, for the tongue and gum (§ 349).

After section of the trigeminus, animals frequently bite their tongue, as they cannot feel the position and movements of this organ in the mouth.

5. The inferior dental is the *sensory* branch to the teeth and gum; the vaso-motor fibres reach it from the superior cervical ganglion. Before it passes into the canal in the lower jaw, it gives off the mylohyoid nerve, which supplies *motor* fibres to the mylohyoid and the anterior belly of the digastric, and also some fibres to the triangularis menti and the platysma; the *muscular sensory nerves* also lie in these branches. The mental nerve, which issues from the mental foramen, is the *sensory* nerve for the chin, under lip, and the skin at the margin of the jaw.

6. The auriculo-temporal gives *sensory* branches to the anterior wall of the external auditory meatus, the tympanic membrane, the anterior part of the ear, the adjoining region of the temple, and to the maxillary articulation.

Fig. 323 shows the distribution of the branches of the trigeminus on the head, and the cervical nerves, so that the distribution of anæsthetic and hyperæsthetic areas may easily be made out.

The **otic ganglion** (*m*) lies beneath the foramen ovale on the inner side of the third division. Its roots are:—1, Short *motor* fibres from the third division; 2, *vaso-motor* from the plexus around the middle meningeal artery, (ultimately derived from the cervical ganglion of the *sympathetic*); 3, fibres (λ) run from the tympanic branch of the glosso-pharyngeal to the tympanic plexus, and from thence through the canaliculus petrosus in the small superficial petrosal in the cranium, then through a small canal between the apex of the petrous bone and

the sphenoid, to reach the otic ganglion. Through the chorda tympani, the facial nerve is constantly connected with the ganglion (Fig. 322).

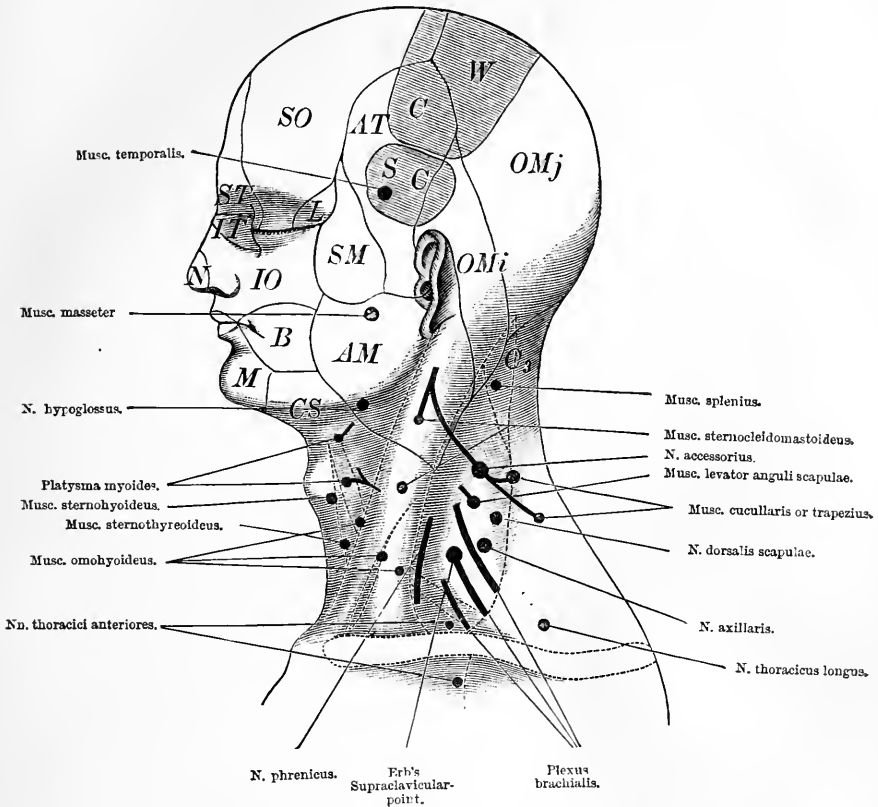

Fig. 323.

Distribution of the sensory nerves on the head as well as the position of the motor points on the neck—*SO*, Area of distribution of the supra-orbital nerve; *ST*, supra-trochlear; *IT*, infra-trochlear; *L*, lachrymal; *N*, ethmoidal; *IO*, infra-orbital; *B*, buccinator; *SM*, subcutaneous malæ; *AT*, auriculo-temporal; *AM*, great auricular; *OMj*, great occipital; *OMi*, lesser occipital; *C₃*, three cervical nerves; *CS*, cutaneous branches of the cervical nerves; *CW*, region of the central convolutions of the brain; *SC*, region of the speech-centre (third left frontal convolution).

The branches of the otic ganglion are:—1, the *motor* twigs for the tensor tympani and tensor of the soft palate (these fibres are mixed with sensory fibres—Ludwig and Politzer); 2, one or more branches connecting the ganglion with the auriculo-temporal are carried by the roots 2 and 3, from the sympathetic and glosso-pharyngeal, which the auriculo-temporal nerve (*A*), as it passes through the parotid gland (*P*),

gives off to the gland. These are the *secretory* fibres for the parotid—their functions are stated in § 145.

Section of the trigeminus is followed by inflammatory changes in the (rabbit) tympanic cavity; the degree of inflammation varies much (Berthold and Grünhagen, Kirchner). Section of the sympathetic or glosso-pharyngeal has no effect.

The **sub-maxillary ganglion** (*L*) lies close to the convex arch of the tympanico-lingual nerve and the excretory duct of the sub-maxillary gland (*M*). Its roots are—

1. Branches of the chorda tympani, *i, i*, (which undergo fatty degeneration after section of facial nerve—Vulpian). This root supplies *secretory* fibres to the sub-maxillary and sub-lingual glands, but it also supplies *vaso-dilator* fibres for the blood-vessels of the same glands (§ 145). In addition, fibres are supplied to the smooth muscular fibres in Wharton's duct. All the fibres of the chorda do not pass into the gland; some pass along with the lingual nerve into the tongue—(see *Chorda*, under *Facial Nerve*).

2. The *sympathetic* root of the ganglion arises from the plexus around the submental branch of the external maxillary artery (*q*), *i.e.*, ultimately from the superior cervical ganglion; it passes to the gland, and contains *secretory* fibres, whose stimulation is followed by the secretion of thick, concentrated, saliva (trophic nerve of the gland). It also carries the vaso-constrictor nerves to the gland (p. 287).

3. The *sensory* root springs from the lingual. Some of the fibres, after passing through the ganglion, supply the gland and its excretory ducts, while a few issue from the ganglion, and again join the tympanico-lingual nerve to reach the tongue.

Pathological.—**Trismus**, or *spasm of the muscles of mastication*, supplied by the third division, is usually bilateral; it may be *clonic* in its nature (chattering of the teeth), or *tonic*, when it constitutes the condition of lock-jaw or trismus. The spasms are usually individual symptoms of more extensive convulsions, more rarely when they occur alone, they are symptomatic of disease of the cerebrum, medulla, pons, and cortex of the frontal convolutions (Eulenburg). The spasms may be caused reflexly, *e.g.*, by stimulation of the sensory nerves of the head.

Paralysis.—*Degeneration of the motor nuclei*, or affections of the intra-cranial root of the nerve causes paralysis of the muscles of mastication, which is very rarely bilateral. Paralysis of the tensor tympani is said to cause difficulty of hearing (Romberg), or buzzing in the ears (Benedict). We require further observations upon this point, as well as upon paralysis of the tensor of the soft palate.

Neuralgia may occur in all the branches of the fifth. It consists of severe attacks of pain shooting into the expansions of the nerves. It is usually unilateral, and in fact, is often confined to one branch, or even to a few twigs of one branch. The point from which the pain proceeds is frequently the bony canal through which the branch issues. The ear, dura mater, and tongue, are rarely attacked. The attack is not unfrequently accompanied by contractions or *twitchings* of the corresponding group of the facial muscles. The twitchings are either reflex, or

are due to direct peripheral irritation of the fibres of the facial nerve, which are mixed with the terminal branches of the trigeminus. The reflex twitchings may be extensively distributed, involving even the muscles of the arm and trunk.

Redness or congestion of the affected part of the face is a not unfrequent symptom in neuralgia, and it may be accompanied by increased or diminished secretion from the nasal and buccal mucous membranes. This is a reflex phenomenon, the sympathetic being affected. Reflex stimulation of the vaso-motor nerves frequently gives rise to *disturbance of the cerebral activities*, owing to changes in the distribution of the blood in the head. Ludwig and Dittmar found that stimulation of sensory nerves caused a reflex contraction of the arterial blood-vessels, and increase of the blood pressure in the cerebral vessels. Sometimes there is melancholy or hypochondriasis, and in one case of violent pain in the inferior maxillary nerve, the attack was accompanied by hallucinations of vision.

The **trophic disturbances** which sometimes accompany affections of the trigeminus are particularly interesting. They are: a brittle character of the *hair*, which frequently becomes grey, or may fall out; circumscribed areas of *inflammation of the skin*, and the appearance of a vesicular eruption upon the face, [often following the distribution of certain nerves] and constituting *herpes*, which may also occur on the cornea, constituting the neuralgic *herpes corneæ* of Schmidt-Rimpler.

Lastly, there is the progressive **atrophy of the face** which is usually confined to one side, but may occur on both sides (Eulenburg, Flasher). It is caused very probably by a trophic affection of the trigeminus, although the vaso-motor nerves may also be affected reflexly. Landois found that in the famous case of Romberg, a man named Schwahn, the sphygmographic tracing of the carotid pulse of the atrophied side was distinctly smaller than on the sound side.

Urbantschitsch made the remarkable observation that stimulation of the branches of the trigeminus, especially those going to the ear, caused an *increase of the sensation of light* in the person so stimulated. Blowing upon the cheeks or nasal mucous membrane, electrical stimulation, the use of snuff, smelling strong perfumes—all temporarily increase the sensation of light. The senses of taste and smell, as well as the sensibility of certain areas of the skin, can all be exalted *reflexly* by gentle stimulation of the trigeminus. In intense affections of the ear, whereby the fibres of the trigeminus are often affected sympathetically, these sensory functions may be diminished. As the ear malady begins to improve, the excitability of these sense organs also again begins to improve.

[Complete section of the trigeminus results in loss of sensibility in all the parts supplied by it (Fig. 323), including one side of the face, temple, part of the ear, the fore part of the head, conjunctiva, cornea, mouth, gums, Schneiderian mucous membrane, anterior two-thirds of the tongue, and part of pharynx. In drinking from a vessel, the patient feels as if one side of it were cut away. The muscles of mastication are paralysed on that side. The mucous membranes tend to ulcerate, that of the mouth being chafed by the teeth, the gums get spongy, the nasal mucous membrane tends to ulcerate, so that smell is interfered with, and ammonia excites no reflex acts, while the eye undergoes panophthalmia.]

348. VI. Nervus Abducens.

Anatomical.—It arises slightly in front of and partly from the nucleus of the *facial nerve* (which corresponds to the anterior horn of the spinal cord), from large-

celled ganglia in the deeper part of the anterior region of the fourth ventricle, (emenientia teres, Fig. in § 366). [Its nucleus is connected with the nucleus of the third nerve of the opposite side.] It appears at the posterior margin of the pons (Fig. 321, VI).

Function.—It is the voluntary nerve of the external rectus muscle. In co-ordinated movements of the eyeballs, however, it is involuntary.

Anastomoses.—Branches reach it from the sympathetic upon the cavernous sinus (Fig. 322). A few come from the trigeminus, and their function is analogous to similar fibres supplied to the trochlearis and oculomotorius.

Pathological.—Complete *paralysis* causes squinting inwards, and consequent diplopia. In dogs, section of the cervical sympathetic causes a slight deviation of the eyeball inwards (Petit). This is explained by the fact that the abducens receives a few motor-fibres from the cervical sympathetic. *Spasm* of the abducens causes external squint.

Squint.—In addition to paralysis or stimulation of certain nerves producing squint, it is to be remembered that it may also be caused by a primary affection of the muscles themselves, *e.g.*, congenital shortness, contracture, or injuries of these muscles. It may also be brought about, owing to *opacities* of the transparent media of the eye; a person with, say an opacity of the cornea, rotates the affected eye involuntarily, so that the rays of light may enter the eye through a clear part of the media.

349. VII. Nervus Facialis.

Anatomical.—This nerve consists entirely of efferent fibres, and arises from the floor of the fourth ventricle from the "*facial nucleus*" (Fig. in § 366), which lies behind the origin of the abducens, and also by some fibres from the nucleus of the abducens, [although Gowers's observations do not confirm this]. Other fibres arise from the lenticular nucleus of the opposite side (§ 378, I). It consists of two roots, the smaller—*portio intermedia* of Wrisberg—forms a connection with the auditory nerve (see § 350). The intermediate portion is to be regarded as a "survival" of a condition present in lower vertebrates, where the facial and glossopharyngeal are united into a single nerve (Duval). Along with the auditory nerve, it traverses the porus acusticus internus, where it passes into the facial or Fallopiian canal. At first it has a transverse direction as far as the hiatus of this canal; it then bends at an acute angle at the "knee" (*a*) above the tympanic cavity, to descend in an osseous canal in the posterior wall of this space (Fig. 322). It emerges from the stylo-mastoid foramen, pierces the parotid gland, and is distributed in a fan-shaped manner (*pes anserinus major*). [The superficial origin is at the lower margin of the pons, in the depression between the olivary body and the restiform body, and is indicated in Fig. 321, VII *a*].

Its branches (Fig. 322, p. 794) are:—

1. The motor, large superficial petrosal (*j*). It arises from the "knee" or geniculate ganglion within the Fallopiian canal, in the cavity of the skull, runs upon the anterior surface of the temporal bone, traverses the foramen lacerum medium on the under surface of the base of the skull, and passes through the Vidian canal to reach the sphenopalatine ganglion (p. 797). It is uncertain whether this nerve conveys *sensory* branches from the second division of the trigeminus to the facial.

2. Connecting branches (β) pass from the geniculate ganglion to the otic ganglion. For the course and function of these fibres, see *Otic ganglion* (p. 800).

3. The motor branch to the stapedius muscle (γ).

4. The chorda tympani (i, i) (Varolius, 1573) arises from the facial before it emerges at the stylomastoid foramen (s), runs through the tympanic cavity (above the tendon of the tensor tympani, between the handle of the malleus and the long process of the incus), passes out of the skull through the petrotympanic fissure, and then joins the lingual nerve at an acute angle (p. 799, 4). Before it unites with this nerve, it exchanges fibres with the otic ganglion (m). Thus, sensory fibres can enter the chorda from the third division of the trigeminus (E. Bischoff), which may run centripetally to the facial to be distributed along with it. In the same way, sensory fibres may pass from the lingual nerve through the chorda, into the facial (Longet). Stimulation of the chorda—which even in man, may be done in cases where the tympanic membrane is destroyed—causes a prickling feeling in the anterior margins and tip of the tongue (Tröltzsch). O. Wolfe found that the section of the chorda in man, abolished the sensibility for *tactile* and *thermal* stimuli upon the tip of the tongue; and the same was true of the sense of *taste* in this region. It is supposed by Calori that these fibres enter the facial nerve at its periphery (especially through the auriculo-temporal into the branches of the facial); that they run in a centripetal direction in the facial, and afterwards pursue a centrifugal course in the chorda. The chorda also contains *secretory* and *vaso-dilator* fibres for the sub-maxillary and sub-lingual glands (see p. 287).

Gustatory Fibres.—The chorda also contains fibres administering to the sense of *taste*, which are conveyed to the tongue along the course of the lingual (p. 799)—(Roux, Baragiola, Inzani, Lussana, Neumann). Urbantschitsch made observations upon a man whose chorda was freely exposed, and in whom its stimulation in the tympanic cavity caused a sensation of taste (and also of touch) in the margins and tip of the tongue. According to Stich, disturbances of the sense of taste *never* occur when there is a purely central paralysis of the facial, but *always* when the paralysis occurs at the stylomastoid foramen (s), and *occasionally* when the facial is interrupted in its course within the temporal bone. The *general* result of the above observation shows that, gustatory fibres must enter the trunk of the facial *outside* the stylomastoid foramen. At first they follow a centripetal direction in the trunk of the facial, and afterwards pass into the chorda. Stich supposes that the auriculo-temporal, by means of its anastomoses on the face, conveys these fibres. This view, however, cannot be maintained, as in paralysis of the whole trigeminus the sense of taste is not affected (Althaus, Vicioli).

It is more probable that the gustatory fibres come from the glosso-pharyngeal. There are several channels open to the fibres. First, apart from a few fibres which the glosso-pharyngeal supplies to the portio intermedia (Duval), there is a channel beyond the stylomastoid foramen, viz., through the ramus communicans cum glosso-pharyngeo (Fig. 322, ϵ), which passes from the last-mentioned nerve in that branch of the facial which contains the motor fibres for the stylohyoid and posterior belly of the digastric (Henle's N. styloideus). This union explains the constant disturbance of taste, following injury to the facial at the stylomastoid foramen. This nerve also supplies muscular sensibility to the stylohyoid and posterior belly of the digastric muscles. It is also assumed that, by means of these anastomoses, motor fibres are supplied by the facial to the glosso-pharyngeal nerve.

A second channel of union of the glosso-pharyngeal and facial nerves occurs in the tympanic cavity. The tympanic branch of the glosso-pharyngeal (λ), passes into this cavity, where it unites in the tympanic plexus with the small superficial petrosal nerve (β), which springs from the knee on the facial. The gustatory fibres may first pass into the otic ganglion, which is always connected with the chorda (otic ganglion—p. 800, 3). Lastly, a third connection is described through a twig (π) from the petrous ganglion of the glosso-pharyngeal, direct to the facial trunk within the Fallopiian canal (Garibaldi).

Vaso-dilator Fibres.—According to some observers, the chorda contains *vaso-dilator* fibres for the anterior portion of the tongue; and, lastly, according to Cl. Bernard, motor fibres for the superficial lingual muscle.

5. **Connection with Vagus.**—Before the chorda is given off, the trunk of the facial comes into direct relation with the auricular branch of the vagus (δ), which crosses it in the mastoid canal (see *Vagus*), and supplies it with sensory fibres.

Pseudo-motor Action.—From 1 to 3 weeks after the section of the hypoglossal nerve, stimulation of the chorda causes movements in the tongue (Philippeaux and Vulpian, R. Heidenhain). These movements are not so energetic, and occur more slowly than those caused by stimulation of the hypoglossal. *Nicotin* first excites, then paralyses the motor effect of the chorda. Even after cessation of the circulation, stimulation of the chorda causes movements. Heidenhain supposes that, owing to the stimulation of the chorda, there is an increased secretion of lymph within the musculature, which acts as the cause of the muscular contraction. He called this action "*pseudo-motor*."

6. **Peripheral Branches.**—After the facial issues from its canal, it supplies motor fibres to the stylohyoid and posterior belly of the digastric, the occipitalis, and also to all the muscles of the external ear and the muscles of expression, to the buccinator and platysma. The facial also contains secretory fibres for the face.—(Compare § 288.)

Although most of the branches of the facial are under the influence of the will, yet most men cannot voluntarily move the muscles of the nose and ear.

Anastomoses.—The branches of the seventh nerve on the face

anastomose with those of the trigeminus. Thus, sensory fibres are conveyed to the muscles of expression. The sensory branches of the auricular branch of the vagus and the great auricular enter the peripheral ends of the facial and supply sensibility to the muscles of the ear, while the sensory fibres of the third cervical nerve similarly supply the platysma with sensibility. Section of the facial, at the stylomastoid foramen is painful, but it is still more so if the peripheral branches on the face are divided (Magendie).—(Compare *Recurrent sensibility*, § 355.)

Pathological.—In all cases of **paralysis** of the facial, the most important point to determine is whether the seat of the affection is in the *periphery*, in the region of the stylomastoid foramen, or in the course of the long Fallopiian canal, or is central (cerebral) in its origin. This point must be determined by an analysis of the symptoms. Paralysis at the stylomastoid foramen is very frequently *rheumatic*,

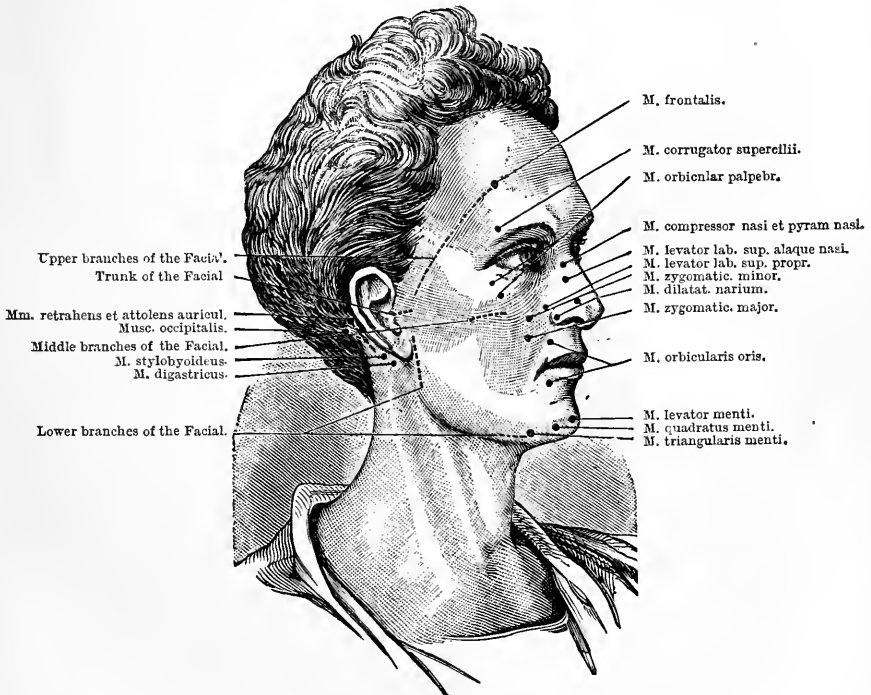

Fig. 324.

Motor points of the facial nerve and the facial muscles supplied by it
(after Eichhorst).

and probably depends upon an exudation compressing the nerve; the exudation probably occupying the lymph-space described by Rüdinger on the inner side of the Fallopiian canal, between the periosteum and the nerve, and which is a continuation of the arachnoid space. Other causes are—Inflammation of the parotid gland, direct injury, and pressure from the forceps during delivery. In the *course of the canal*, the causes are—Fracture of the temporal bone, effusion of blood into the

canal, syphilitic effusions, and caries of the temporal bone; the last sometimes occurs in inflammation of the ear. Amongst *intracranial* causes are—Affections of the membranes of the brain, and of the base of the skull in the region of the nerve, disease of the “*facial nucleus*;” lastly, affection of the cortical centre of the nerve and its connections with the nucleus. [No nerve is so liable as the seventh to be paralysed independently].

Symptoms of Unilateral Paralysis of the Facial or [Bell's Paralysis].—

1. *Paralysis of the muscles of expression*: The forehead is smooth, without folds, the eyelids remain open (*Lagophthalmus paralyticus*), the outer angle being slightly lower. The anterior surface of the eye rapidly becomes dry, the cornea is dull, as, owing to the paralysis of the orbicularis, the tears are not properly distributed over the conjunctiva, and, in fact, in consequence of the dryness of the eyeball, there may be temporary inflammation (*Keratitis xerotica*). In order to protect the eyeball from the light, the patient turns it upwards under the upper eyelid (Bell), relaxes the levator palpebræ, which allows the lid to fall somewhat (Hasse). The nose is immovable, while the naso-labial fold is obliterated. As the nostrils cannot be dilated, the sense of smell is interfered with. The impairment of the *sense of smell* depends more, however, upon the imperfect conduction of the tears, owing to paralysis of the orbicularis palpebrarum and Horner's muscle, and thus causing dryness of the corresponding side of the nasal cavity. Horses, which distend the nostrils widely during respiration, after section of both facial nerves are said by Cl. Bernard to die from interference with the respiration, or at least they suffer from severe dyspnoea (Ellenberger). The face is drawn towards the sound side, so that the nose, mouth, and chin are oblique.

Paralysis of the buccinator interferes with the proper *formation of the bolus* of food (p. 299); the food collects between the cheek and the gum, from which it is usually removed by the patient with his fingers; saliva and fluids escape from the angle of the mouth. During vigorous expiration, the cheeks are puffed outwards like a sail. The *speech* may be affected owing to the difficulty of sounding the *labial consonants* (especially in double paralysis), and the vowels, u, ü (ue), ö (oe); while the speech, in paralysis of the branches to both sides of the palate, becomes nasal (§ 628—Cuming). The acts of whistling, sucking, blowing, and spitting are interfered with.

In double paralysis, many of these symptoms are greatly intensified, while others, such as the oblique position of the features disappear. The features are completely relaxed; there is no mimetic play of the features, the patients weep and laugh, “as it were, behind a mask” (Romberg). 2. In paralysis of the palate, when the uvula is directed towards the sound side, and the paralysed half of the palate hangs down and cannot be raised (large superficial petrosal nerve), it is not determined to what extent this condition influences the *act of deglutition* and the *formation of the consonants*. *Taste* is interfered with; either it is absent on the anterior two-thirds of the tongue, or the sensation is delayed and altered. This is due to an affection of the chorda. 4. *Diminution of saliva* on the affected side was first described by Arnold; still, we must determine to what extent a simultaneous affection of the sense of taste may cause a reflex interference with the secretion of saliva, or whether rapid removal of the saliva through the opened lips and angle of the mouth may cause the dryness on the affected side of the mouth. 5. Roux pointed out that *hearing* is affected, the *sensibility to sounds* being increased (*Oxyakoia, sive Hyperakusis Willisiana*.) The paralysis of the stapedius muscle makes the stapes loose in the fenestra ovalis, so that all impulses from the tympanum act vigorously upon the stapes, which consequently excites considerable vibrations in the fluid of the inner ear. More rarely, in paralysis of the stapedius, it has been observed that low notes are heard at a greater distance than on the sound side (Lucae, Moos).

As the facial in man appears to contain fibres for the *secretion of sweat*, this explains the loss of the power of sweating in the face, when the nerve begins to atrophy (Strauss, Bloch).

Section of the facial in young animals causes atrophy of the corresponding *muscles*. The *facial bones* are also imperfectly developed; they remain smaller, and hence the bones of the sound side of the face grow towards, and ultimately across, the middle line towards the affected side (Brown-Séguard, Brücke, Schauta, Gudden). The *salivary glands* also remain smaller (Brücke).

Stimulation—or irritation in the area of the *facial*—causes partial or extensive, either direct or reflex, tonic or clonic spasms. The extensive forms are known as “*mimetic facial spasm*.” Amongst the partial forms, are *tonic contraction of the eyelid* (*Blepharospasm*) which is most common; and is caused reflexly by stimulation of the sensory nerves of the eye—*e.g.*, in scrofulous ophthalmia, or from excessive sensibility of the retina (*photophobia*). More rarely the excitement proceeds from some more distant part—*e.g.*, in one cause recorded by v. Gräfe, from inflammatory stimulation of the anterior palatine arch. The centre for the reflex is the facial nucleus.

The clonic form of spasm—*spasmodic winking* (*Spasmus nictitans*), is usually of reflex origin, due to irritation of the eye, the dental nerves, or even of more distant nerves. In severe cases, the affection may be bilateral, and the spasms may extend to the muscles of the neck, trunk, and upper extremities. Contraction of the muscles of the lip may be excited by emotions (rage, grief), or reflexly. Fibrillar contractions occur after section of the facial as a “*degeneration-phenomenon*” (p. 640). *Intracranial* stimulation of the most varied description may cause spasms. Lastly, facial spasm may be part of a general spasmodic condition, as in epilepsy, chorea, hysteria, tetanus. Aretæus (SI A.D.) made the interesting observation that the muscles of the ear contracted during tetanus. Very rarely have spasmodic elevation of the palate and increased salivation been described as the result of irritation of the facial (Leube). Moos observed a profuse secretion of saliva on stimulating the chorda during an operation on the tympanic cavity.

350. VIII. Nervus Acusticus.

Anatomical.—This nerve arises from *two nuclei* (Stieda), whose ganglionic cells anastomose. The nuclei lie in the broadest part of the calamus scriptorius; a process from a spinal centre reaches them (Roller). The *anterior nucleus*, which is connected with the portio intermedia Wrisbergii, appears to contain *vaso-motor* fibres. Part of its fibres run through the pedunculus cerebelli to the cerebellum; very probably they are connected with the regulation of the equilibrium. The white stria medullares, which run transversely across the floor of the fourth ventricle, are said to pass into the pedunculus cerebelli of the opposite side. According to Meynert, fibres of the auditory nerve pass in channels as yet undetermined from the *cerebellum* to the pedunculus cerebri, and ultimately to the cortex of the brain, in which in the tempero-sphenoidal lobes is placed their cortical centre (§378, IV.). In the sheep and horse, the two chief branches of the auditory nerve—the cochlear and vestibular nerves—arise separately, which points to the independence of their functions (Horbaczewski)—(Fig. 321, VII *b*). In the course of the internal auditory meatus, the auditory and portio intermedia of the facial exchange fibres, but the physiological significance of this is unknown.

Function.—The acusticus or auditory nerve has a *double* function:—

1. It is the *nerve of hearing*; when stimulated, either at its origin, in its course, or at its peripheral terminations, it gives rise to *sensations*

of sound. Every injury, according to its intensity and extent, causes hardness of hearing or even deafness.

2. Quite distinct from the foregoing is the other function, which depends upon the *semicircular canals*—viz., that stimulation of the peripheral expansions in the ampullæ influences the movements necessary for maintaining the equilibrium of the body.

Brenner's Formula.—The relation of the auditory nerve to the galvanic current is very important. In healthy persons, when there is closure at the cathode, there is the sensation of a *clang* (or tone) in the ear, which continues with variations while the current is closed. When the anode is opened, there is a feebler tone (*Brenner's Normal Acoustic Formula*). This clang coincides exactly with the resonance fundamental tone of the sound-conducting apparatus of the ear itself.

Pathological.—*Increased sensibility* of the auditory nerve in any part of its course, its centre, or peripheral expansions causes the condition known as *hyperakusis*, which usually is a sign of extensive, increased nervous excitability, as in hysteria. When excessive, it may give rise to distinctly painful impressions, which condition is known as *acoustic hyperalgia* (Eulenburg). *Stimulation* of the parts above-named causes sensations of sound, the most common being the sensation of *singing in the ears*, or *tinnitus*. This condition is often due to changes in the amount of blood in the blood-vessels of the ear—either anæmic or hyperæmic stimulation. There is well marked tinnitus after large doses of quinine or salicin, due to the vaso-motor effect of these drugs upon the vessels of the labyrinth (Kirchner). Not unfrequently in cases of tinnitus, the reaction due to the galvanic current is often increased. More rarely there is the so-called "*paradoxical reaction*"—i.e., on applying the galvanic current to one ear, in addition to the reaction in this ear, there is the opposite result in the non-stimulated ear. In other cases of disease of the auditory nerve, noises rather than musical notes are produced by the current; *stimulation*, especially of the cortical centre of the auditory nerve, chiefly in lunatics, may cause *auditory delusions* (§378, IV.). According as the excitability of the auditory nerve is diminished or abolished, there is the condition of nervous hardness of hearing (*Hypakusis*), or nervous deafness (*Anakusis*).

The Semicircular Canals of the Labyrinth.—Section or injury to these canals does not interfere with hearing, but other important symptoms follow their injury, such as disturbances of equilibrium due to a feeling of giddiness, especially when the injury is bilateral (Flourens). This does not occur in fishes (Kieselbach).

The *pendulum-like movement of the head* in the direction of the plane of the injured canal is very characteristic. If the *horizontal canal* is divided, the head (of the pigeon) is turned alternately to the right and left. The rotation takes place, especially when the animal is about to execute a movement; when it is at rest, the movement is less pronounced. The phenomenon may last for months, and injury to the *posterior vertical canals* causes a well-marked up and down movement or nodding of the head, the animal itself not unfrequently falling forwards or backwards. Injury to the *superior vertical canals* also causes pendulum-like vertical movements of the head, while the animal often falls forwards. When *all the canals* are destroyed, various pendulum-like movements are performed, while standing is often impossible. Breuer found that electrical

stimulation of the canals caused rotation of the head, while Landois, on applying a solution of salt to the canals, observed pendulum-like movements, which, however, disappeared after a time. A 25 per cent. solution of chloral dropped into the ear of a rabbit causes, after 15 minutes, a similar destruction of the canals (Vulpian). Section of the acoustic nerves within the cranium has the same result (Bechterew).

Explanation.—Goltz regards the canals as organs of sense for ascertaining the equilibrium or position of the head in space; Mach, as an organ for ascertaining the movements of the head. According to Goltz's **statical theory**, every position of the head causes the endolymph to exert the greatest pressure upon a certain part of the canals, and thus excites in a varying degree the nerve-terminations in the ampullæ. According to Breuer, when the head is rotated, currents are produced in the endolymph of the canals, which must have a fixed relation to the direction and extent of the movements of the head, and these currents, therefore, when they are perceived, afford a means of determining the movement of the head. The nerve end-organs of the ampullæ are arranged for ascertaining this perception. If the semicircular canals are an apparatus—in fact, “sense-organs” (Goltz)—for the sensation of the equilibrium, and whose function is to determine the position or movements of the head, necessarily their destruction or stimulation must alter these perceptions, and so give rise to abnormal movements of the head. Vulpian regards the rotation of the head as due to strong auditory perceptions (?) in consequence of affections of the canals. Böttcher, Tomaszewicz, and Baginsky regard the injury to the cerebellum as the cause of the phenomena. The pendulum-like movements, however, are so characteristic that they cannot be confounded with disturbances of the equilibrium which result from injury to the cerebellum.

Kinetic Theory.—In 1875 Crum Brown pointed out that if a person be rotated passively, his eyes being bandaged, he can, up to a certain point, indicate pretty accurately the amount of movement, but after a time this cannot be done, and if the rotation, as on a potter's wheel, be stopped, the sense of rotation continues. Crum Brown suggested that currents were produced in the endolymph, while the terminal hair-cells lagged behind, and were, in fact, dragged through the fluid. He pointed out that the right posterior canal is in line with the left superior, and the left posterior with the right superior, a fact which is readily observed by looking from behind at a skull, with the semicircular canals exposed (Fig. 325). He assumes that the canals are paired organs, and that each pair is connected with rotation or movement of the head in a particular direction.

Giddiness.—This feeling of false impressions as to the relations of the surroundings, and consequent movements of the body, occurs especially during *acquired* changes in the normal movements of the eyes, whether due to involuntary to and fro movements of the

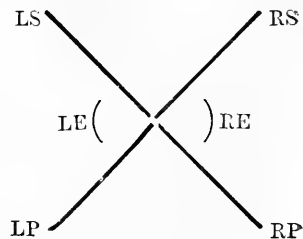

Fig. 325.

Diagram of the disposition of the semicircular canals—RS and LS, right and left superior; LP and RP, right and left posterior; LE and RE, right and left external.

eyeballs (*nystagmus*), or to paralysis of some eye muscle.

Active or passive movements of the head or of the body are

normally accompanied by simultaneous movements of both eyeballs, which are characteristic for every position of the body. The general character of these "compensatory" bilateral movements of the eyes consists in this, that during the various changes in the position of the head and body, the eyes strive to maintain their primary passive position. Section of the aqueduct of Sylvius at the level of the corpora quadrigemina, of the floor of the fourth ventricle, of the auditory-nucleus, both acustici, as well as destruction of both membranous labyrinths, causes disappearance of these movements; while, conversely, stimulation of these parts is followed by bilateral associated movements of the eyeballs.

Compensatory movements of the eyeballs, under normal circumstances, may be caused reflexly from the membranous labyrinth. Nerve channels, capable of exciting reflex movements of both eyes, proceed from both labyrinths, and, indeed, both eyes are affected from both labyrinths. These channels pass through the auditory nerve to the centre (nuclei of the 3rd, 4th, 6th, and 8th cranial nerves), and from the latter efferent fibres pass to the muscles of the eye (Högyes).

Cyon found that stimulation of the horizontal semicircular canal was followed by horizontal nystagmus; of the posterior, by vertical, and of the anterior canal, by diagonal nystagmus. Stimulation of one auditory nerve is followed by rotating nystagmus, and rotation of the body of the animal on its axis towards the stimulated side.

Chloroform and other poisons enfeeble the compensatory movements of the eyeballs, while nicotin and asphyxia suppress them, owing to their action on their nerve centre.

It is probable that the disturbances of equilibrium and the feeling of giddiness, which follow the passage of a galvanic current through the head between the mastoid processes, are also due to an action upon the semicircular canals of the labyrinth (§ 380). Deviation of the eyeballs is produced by such a galvanic current (Hitzig). The same result is produced when the two electrodes are placed in the external auditory meatuses.

Pathological—Menière's Disease.—The feeling of giddiness, not unfrequently accompanied by tinnitus, which occurs in *Menière's disease*, must be referred to an affection of the nerves of the ampullæ or their central organs, or of the semicircular canals themselves. By injecting fluid violently into the ear of a rabbit, giddiness, with nystagmus and rotation of the head towards the side operated on, are produced (Baginsky). In cases in man, where the tympanic membrane was defective, Lucaë, when employing the so-called ear-air-douche at 0.1 atmosphere, observed abduction of the eyeball with diplopia, giddiness, darkness in front of the eyes, while the respiration was deeper and accelerated. These phenomena must be due to stimulation or exhaustion of the vestibular branch of the auditory nerve (Högyes). In chronic gastric catarrh, a tendency to giddiness is an occasional symptom (Trousseau's gastric giddiness). This may, perhaps, be caused by stimulation of the gastric nerves exciting the vaso-motor nerves of the labyrinth, which must affect

the pressure of the endolymph. Analogous giddiness is excited from the larynx (Charcot), and from the urethra (Erlenmeyer).

[**Vertigo** or giddiness is a very common symptom in disease, and may be produced by a great many different conditions. It is sometimes due to a want of harmony between the impressions derived from different sense-organs or "contradictoriness of sensory impressions" (Grainger Stewart), as is sometimes felt on ascending or descending a stair, or by some persons while standing on a high tower, constituting tower or cliff giddiness. One of the most remarkable conditions is that called "*Agoraphobia*" (Benedikt, Westphal). The person can walk quite well in a narrow lane or street, but when he attempts to cross a wide square, he experiences a feeling closely allied to giddiness. The giddiness of sea-sickness is proverbial, while some persons get giddy with waltzing or swinging. Besides occurring in Menière's disease, it sometimes occurs in locomotor ataxia, and some cerebral and cerebellar affections, including cerebral anaemia. Very distressing giddiness and headache are often produced by paralysis of some of the ocular muscles—*e.g.*, the external rectus. The forms of dyspeptic giddiness and the toxic forms due to the abuse of alcohol, tobacco, and some other drugs are familiar examples of this condition.]

351. IX. Nervus Glosso-pharyngeus.

Anatomical.—This nerve (Fig. 322, 9) arises from the nucleus of the same name, which consists partly of large cells (motor) and partly of small cells (belonging to the gustatory fibres). The nucleus lies in the lower half of the fourth ventricle, deep in the medulla oblongata, near the olive (Fig. in § 366). The nucleus is connected with that of the vagus. A special root *ascending* from the spinal cord applies itself to the fibres, and perhaps (like the spinal roots of the 2nd and 8th nerves) serves for the production of spinal reflexes (Roller). The fibres collect into two trunks, which afterwards unite and leave the medulla oblongata in front of the vagus. In the fossula petrosa it has on it the *petrous ganglion*, from which, occasionally, a special part on the posterior twig is separated within the skull as the ganglion of Ehrenritter. *Communicating branches* are sent from the petrous ganglion to the trigeminus, facial (ϵ and π), vagus and carotid plexus. From this ganglion also the tympanic nerve (λ) ascends vertically in the tympanic cavity, where it unites with the tympanic plexus. This branch (§ 349, 4) gives *sensory* fibres to the tympanic cavity and the Eustachian tube; while, in the dog, it also carries secretory fibres for the parotid into the small superficial petrosal nerve (Heidenhain—§ 145).

Function.—(1.) It is the nerve of taste for the posterior third of the tongue, the lateral part of the soft palate, and the glosso-palatine arch (compare § 422).

The nerve of taste for the anterior two-thirds of the tongue is referred to under the lingual (§ 347, III, 4), and chorda tympani (§ 349, 4) nerves. The glossal branches are provided with ganglia, especially where the nerve divides at the base of the circumvallate papillæ (Remak, Kölliker, Schwalbe, Stirling). The nerve ends in the circumvallate papillæ (Fig. 320, U), and the end-organs are represented by the taste bulbs (§ 422).

(2.) It is the sensory nerve for the posterior third of the tongue, the anterior surface of the epiglottis, the tonsils, the anterior palatine arch, the soft palate, and a part of the pharynx. From this nerve there may

be discharged *reflexly*, movements of deglutition, of the palate and pharynx (Volkmann), which may pass into those of vomiting (§ 158). These fibres, like the gustatory fibres, can excite a reflex secretion of saliva (p. 290).

(3.) It is the motor nerve for the stylo-pharyngeus and middle constrictor of the pharynx (Volkmann); and, according to other observers, to the (?) glosso-palatinus (Hein) and the (? ?) Levator veli palatini and azygos uvulæ, (compare *Spheno-palatine ganglion*, p. 797). It is doubtful whether the glosso-pharyngeal nerve is really a motor nerve at its origin—although Meynert, Huguenin, W. Krause, and Duval have described a motor nucleus—or whether the motor fibres reach the nerve at the petrous ganglion, through the communicating branch from the facial.

(4.) A twig accompanies the lingual artery (Cruveilhier)—this nerve, perhaps, is *vaso-dilator* for the lingual blood-vessels.

Pathological.—There are no satisfactory observations on man, of uncomplicated affections of the glosso-pharyngeal nerve.

352. X. Nervus Vagus.

Anatomical.—The nucleus from which the vagus arises along with the 9th and 11th nerve is in the ala cinerea in the lower half of the calamus scriptorius (Fig. in § 366), [and it is very probably the representative of the cells of the vesicular column of Clarke]. It leaves the medulla oblongata by 10 to 15 threads behind the 9th nerve, between the divisions of the lateral column, and has a ganglion (jugular) upon it in the jugular foramen. Its branches contain fibres which subserve different functions.

1. The sensory meningeal branch from the jugular ganglion, accompanies the vaso-motor fibres of the sympathetic on the middle meningeal artery, and sends fibres to the occipital and transverse sinus.

When it is irritated, as in congestion of the head and inflammation of the dura mater, it gives rise to *vomiting*.

2. The auricular branch (from the jugular ganglion) receives a communicating branch from the petrous ganglion of the 9th nerve, traverses the canaliculus mastoideus, crossing the course of the facial, with which it exchanges fibres whose function is unknown. On its course, it gives *sensory* branches to the posterior part of the auditory meatus and the adjoining part of the outer ear. A branch runs along with posterior auricular branch of the facial, and confers *muscular sensibility* on the muscles.

When this nerve is irritated, either through inflammation or by the presence of foreign bodies in the outer ear passage, it may give rise to *vomiting*. Stimulation of the deep part of the external auditory meatus in the region supplied by the auricular branch causes *coughing* reflexly [*e.g.*, from the presence of a pea in the ear] (Cassius, Felix, 97 A.D.). Similarly, *contraction of the blood-vessels of the ear* may be caused reflexly (Snellen, Lovèn).

The nerve is the remainder of a considerable branch of the vagus which exists in fishes and the larvæ of frogs, and runs under the skin along the side of the body (Johannes Müller).

3. The **connecting** branches of the vagus are:—1. A branch which directly connects the petrous ganglion of the 9th with the jugular ganglion of the 10th; its function is unknown. 2. Directly above the plexus gangliiformis vagi, the vagus is joined by the whole inner half of the *spinal accessory*. This nerve conveys to the vagus the *motor fibres* for the *larynx* (Bischoff, 1832), and the *cervical part of the œsophagus* (which according to Steiner lie in the inner part of the nerve-trunk), as well as the *inhibitory fibres* for the *heart* (Cl. Bernard). 3. The plexus gangliiformis fibres, whose function is unknown, join the trunk of the vagus from the hypoglossal, superior cervical ganglion of the sympathetic, and the cervical plexus.

4. **Pharyngeal Plexus.**—The vagus sends one or two branches from the upper part of the plexus gangliiformis to the *pharyngeal plexus*, where at the level of the middle constrictor of the pharynx, it is joined by the pharyngeal branches of the 9th nerve and those of the upper cervical sympathetic ganglion, near the ascending pharyngeal artery, to form the *pharyngeal plexus*. The vagal fibres in this plexus supply the *three constrictors of the pharynx* with *motor fibres*, while the tensor palati (compare *Otic ganglion*, p. 800) and levator of the soft palate (compare *Spheno-palatine ganglion*, p. 797) also receive motor (? sensory) fibres. *Sensory* fibres of the vagus from the pharyngeal plexus supply the pharynx from the part beneath the soft palate downwards. These fibres excite the pharyngeal constrictors reflexly during the act of swallowing (compare p. 307). If stimulated very strongly they may cause *vomiting*. (The *sympathetic* fibres of the œsophageal plexus give vaso-motor nerves to the œsophageal vessels; for the œsophageal branches of the 9th nerve see above).

5. The vagus supplies two branches to the larynx, the **superior and inferior laryngeal**.

(a). The **superior laryngeal** receives *vaso-motor* fibres from the superior cervical ganglion of the sympathetic. It divides into two branches, external and internal:—1. The **external** branch receives *vaso-motor* fibres from the same source, (they accompany the superior thyroid artery), and supply the cricothyroid muscle with *motor* fibres, and *sensory* fibres to the lower lateral portion of the laryngeal mucous membrane. 2. The **internal** branch gives off *sensory* branches only; to the glosso-epiglottidean fold, and the adjoining lateral region of the root of the tongue, the aryepiglottidean fold, and to the whole anterior part of the larynx, except the part supplied by the external branch (Longet). Stimulation of all these sensory fibres causes *coughing* reflexly.

Coughing is produced by stimulation of the sensory branches of the vagus to the tracheal mucous membrane, especially at the bifurcation, and also from the bronchial mucous membrane. Coughing is also caused by stimulation of the auricular branch of the vagus, especially in the deep part of the external auditory meatus, of the pulmonary tissue, especially when altered pathologically; in pathological conditions (inflammation) of the pleura (? certain changes in the stomach [stomach-cough]), of the liver and spleen (Naunyn). The *coughing centre* is said to lie on each side of the raphe, in the neighbourhood of the ala cinerea (Kohts). Cases of violent coughing may, owing to stimulation of the pharynx, be accompanied by *vomiting* as an associated movement—(compare p. 249).

The cough (dog, cat) caused by stimulation of the trachea and bronchi occurs at once, and lasts as long as the stimulus lasts; in stimulation of the larynx, the first effect is inhibition of the respiration, accompanied by movements of deglutition, while the cough occurs after the cessation of the stimulation (Kandarazky).

The **superior laryngeal** contains afferent fibres which, when stimulated, cause *arrest of the respiration* and closure of the rima glottidis (Rosenthal)—(see *Respiratory centre*, § 368). Lastly, fibres which are efferent and serve to excite the vaso-motor centre, and are in fact "*pressor fibres*"—(see *Vaso-motor centre*, § 371, II).

(b). The **inferior laryngeal** (recurrent) bends on the left side around the arch of the aorta, and on the right, around the subclavian, and ascends in the groove between the trachea and œsophagus, giving *motor* fibres to these organs, and the lower constrictors of the pharynx, and passes to the larynx, to supply *motor* fibres to all its muscles, except the cricothyroid. It also has an inhibitory action upon the respiratory centre (see § 368).

A **connecting branch** runs from the superior laryngeal to the inferior, (the anastomosis of Galen), which occasionally gives off *sensory* branches to the upper half of the trachea (sometimes to the larynx?); perhaps also to the œsophagus (Longet), and sensory fibres (?) for the muscles of the larynx supplied by the recurrent laryngeal. According to François Franck, sensory fibres pass by this anastomosis from the recurrent into the superior laryngeal. According to Waller and Burckhard, the motor fibres of both laryngeal nerves are all derived from the accessorius; while Chauveau maintains that the cricothyroid is an exception.

Stimulation of the superior laryngeal is painful, and causes contraction of the cricothyroid muscle, (while the other laryngeal muscles contract *reflexly*). Section of both nerves, owing to paralysis of the cricothyroids causes slight slowing of the respirations (Sklarek). In dogs, the voice becomes deeper and coarser, owing to diminished tension of the vocal cords (Longet). The larynx becomes insensible, so that saliva and particles of food pass into the trachea and lungs,

without causing reflex contraction of the glottis or coughing. This excites "traumatic pneumonia," which results in death (Friedländer).

Stimulation of the recurrenents causes *spasm of the glottis*. Section of these nerves paralyzes the laryngeal muscles supplied by them, the voice becomes husky and hoarse (in the pig—Galen, Riolan, 1618), in man, dog, and cat; while rabbits retain their shrill cry. The glottis is small, with every inspiration the vocal cords approximate considerably at their anterior parts, while during expiration, they are relaxed and are separated from each other. Hence, the inspiration, especially in young individuals, whose glottis respiratoria is narrow, is difficult and noisy (Legallois); while the expiration takes place easily. After a few days, the animal (carnivore) becomes more quiet, it respire with less effort, and the passive vibratory movements of the vocal cords become less. Even after a considerable interval, if the animal be excited, it is attacked with severe dyspnoea, which disappears only when the animal has become quiet again. Owing to paralysis of the laryngeal muscles, foreign bodies are apt to enter the trachea, while the paralysis renders difficult the first part of the process of swallowing in the œsophageal region. Broncho-pneumonia may be produced (Arnsperger).

6. The depressor nerve, which in the rabbit arises by one branch from the superior laryngeal, and usually also by a second root from the trunk of the vagus itself, [runs down the neck in close relation with the vagus, sympathetic, and carotid artery, enters the thorax], and joins the cardiac plexus (Fig. 326, *sc*). It is an *afferent* nerve, and when its *central* end is stimulated, it diminishes the energy of the vaso-motor centre, and thus causes a fall of the blood-pressure (hence, the name given to it by Cyon and Ludwig—compare § 371, II). At the same time, [if the vagus on the opposite side be intact], its stimulation affects the *cardio-inhibitory centre*, and thus reflexly diminishes the number of heart-beats. [Its stimulation also gives rise to *pain*, so that it is the sensory nerve of the heart.]

[If in a rabbit the vagi be divided in the middle of the neck, and the

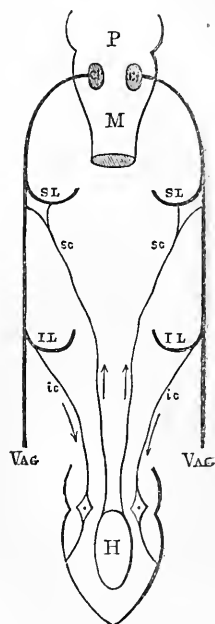

Fig. 326.

Scheme of the cardiac nerves in the rabbit—P, pons; M, medulla oblongata; VAG, vagus; SL, superior laryngeal; IL, inferior laryngeal; *sc*, superior cardiac or depressor; *ic*, inferior cardiac or cardio-inhibitory; H, heart.

central end of the depressor nerve, which is the smallest of the three nerves near the carotid, be stimulated, after a short time there is no alteration of the heart-beats, but there is a steady fall of the blood-pressure (Fig. 76), which is due to a reflex inhibition of the vaso-motor centre, resulting in a dilatation of the blood-vessels of the abdomen. Of course, if the vagi be intact, there is a reflex inhibitory effect on the heart. It is doubtful if the depressor comes into action when the heart is over-distended. If it did, of course the blood-pressure would be reduced by the reflex dilatation of the abdominal blood-vessels.]

The depressor nerve is present in the cat (Bernhardt), hedgehog (Aubert, Röver); rat and mouse; in the horse and in man, fibres analogous to the depressor re-enter the trunk of the vagus (Bernhardt, Kreidmann). Depressor fibres are also found in the rabbit in the trunk of the vagus (Dreschfeldt, Stelling).

7. The cardiac branches, as well as the cardiac plexus, have been described in § 57. These nerves contain the *inhibitory fibres for the heart* (Fig. 326, *ic*—cardio-inhibitory—Edward Weber, November, 1845; Budge, independently in May, 1846), also *sensory fibres for the heart* [in the frog (Budge), and partly in mammals (Goltz).] Lastly, in some animals the heart receives some of the *accelerating fibres* through the trunk of the vagus. Feeble stimulation of the vagus occasionally causes acceleration of the beats of the heart (Schiff, Moleschott, Gianuzzi). In an animal poisoned with nicotin or atropin, which paralyses the inhibitory fibres of the vagus, stimulation of the vagus is followed by acceleration of the heart-beats (Schiff, Schmiedeberg).

8. The pulmonary branches of the vagus join the anterior and posterior pulmonary plexuses. The *anterior* pulmonary plexus gives *sensory* and *motor* fibres to the trachea, and runs on the anterior surface of the branches of the bronchi into the lungs. The posterior plexus is formed by 3 to 5 large branches from the vagus, near the bifurcation of the trachea, together with branches from the lowest cervical ganglion of the sympathetic and fibres from the cardiac plexus. The plexuses of opposite sides exchange fibres, and branches are given off which accompany the bronchi in the lungs. *Ganglia* occur in the course of the pulmonary branches in the frog (Arnold, W. Stirling), [newt—W. Stirling; and in mammals (Remak, Egerow, W. Stirling)], in the larynx [Cock, W. Stirling], in the trachea and bronchi [W. Stirling, Kandarazki]. Branches proceed from the pulmonary plexus to the pericardium and the superior vena cava (Luschka, Zuckerkandl).

The functions of the pulmonary branches of the vagus are—1, They supply *motor* branches to the smooth muscles of the whole bronchial system (compare p. 225); 2, they supply a small part of the *vaso-*

motor nerves of the pulmonary vessels (Schiff), but by far the largest number of these nerves (? all) is supplied from the connection with the sympathetic (in animals from the first dorsal ganglion)—(Brown-Séguard, A. Fick, Badoud, Lichtheim); 3, they supply *sensory* (cough-exciting) fibres to the whole bronchial system, and to the lungs; 4, they give afferent fibres, which, when stimulated, diminish the activity of the *vaso-motor centre*, and thus cause a fall of the blood-pressure during forced expiration (p. 149); 5, and similar fibres which act upon the inhibitory centre of the heart, and so influence it as to accelerate the pulse-beats (compare § 369, II). Simultaneous stimulation of 4 and 5 alters the pulse rhythm (Sommerbrodt); 6, they also contain *afferent* fibres from the pulmonary parenchyma to the medulla oblongata, which *stimulate* the respiratory centre. [These fibres are continually in action], and consequently section of both vagi is followed by diminution of the number of respirations; the respirations become deeper at the same time, while the same volume of air is changed (Valentin). Stimulation of the *central* end of the vagus again accelerates the respirations (Traube, J. Rosenthal). Thus laboured and difficult respiration is explained by the fact that the influences conveyed by these fibres which excite the respiratory centre reflexly, are cut off; so it is evident that centripetal or afferent impulses proceeding upwards in the vagus are intimately concerned in maintaining normal reflex respiration; after these nerves are divided, conditions exciting the respiratory movements must originate *directly*, especially in the medulla oblongata itself (§ 368).

Pneumonia after Section of both Vagi.—The inflammation which follows section of both vagi has attracted the attention of many observers, since the time of Valsalva, Morgagni (1740), and Legallois (1812). In offering an explanation of this phenomenon, we must bear in mind the following considerations:—(a) Section of both vagi is followed by loss of *motor* power in the muscles of the larynx, as well as the *sensibility* of the larynx, trachea, bronchi, and the lungs, provided the section be made above the origin of the superior laryngeal nerves. Hence, the glottis is not closed during swallowing, nor is it closed reflexly when foreign bodies (saliva, particles of food, irrespirable gases) enter the respiratory passages. Even the reflex act of *coughing* which, under ordinary circumstances, would get rid of the offending bodies is abolished. Thus, foreign bodies may readily enter the lungs, and this is favoured by the fact that, owing to the simultaneous paralysis of the œsophagus, the food remains in the latter for a time, and may therefore easily enter the larynx. That this constitutes one important factor was proved by Traube, who found that the pneumonia was prevented when he caused the animals to respire by means of a tube inserted into the trachea, through an aperture in the neck. If, on the contrary, only the motor recurrent nerves were divided and the œsophagus ligatured, so that in the process of attempting to swallow, food must necessarily enter the respiratory passages, “*traumatic pneumonia*” was the invariable result (Traube, O. Frey). (b) A second factor depends on the circumstance that, owing to the laboured and difficult respiration, the *lungs become surcharged with blood*, because during the long time that the thorax is distended, the pressure

of the air within the lungs is abnormally low. This condition of congestion or abnormal filling of the pulmonary vessels with blood, is followed by *serous exudation* (pulmonary œdema), and even by exudation of blood and the formation of pus in the air vesicles (Frey). This same circumstance favours the entrance of fluids through the glottis (§ 352, *b*). The introduction of a tracheal cannula will prevent the entrance of fluids and the occurrence of inflammation. It is probable that a partial *paralysis* of the *pulmonary vaso-motor* nerves may be concerned in the inflammation, as this conduces to an engorgement of the pulmonary capillaries. (*c*) Lastly, it is of consequence to determine whether *trophic* fibres are present in the vagus, and which may influence the normal condition of the pulmonary tissues. According to Michaelson, the pneumonia which takes place *immediately* after section of the vagi, occurs especially in the lower and middle lobes; the pneumonia which follows section of the recurrens occurs *more slowly*, and causes catarrhal inflammation, especially in the upper lobes. Rabbits, as a rule, die within 24 hours after, with all the symptoms of pneumonia; when the above-mentioned precautions are taken, they may live for several days. Dogs may live for a long time. If the 9th, 10th, and 12th nerves be torn out on one side in a rabbit, death takes place from pneumonia (Grünhagen). In *birds*, bilateral section of the vagi is not followed by pneumonia (Blainville, Billroth), owing to the fact that the upper larynx remains closed—death takes place in eight to ten days with the symptoms of *inanition* (Einbrodt, Zander, v. Anrep), while the *heart* undergoes *fatty degeneration* (Eichhorst), and so do the liver, stomach, and muscles (v. Anrep). According to Wassilieff, the heart shows parenchymatous swelling and slight wax-like degeneration. *Frogs*, which at every respiration open the glottis, and close it during the pause, die of asphyxia. Section of the pulmonary branches has no injurious effect (Bidder).

9. The œsophageal plexus is formed principally by branches from the vagus above the inferior laryngeal, from the pulmonary plexus, and below from the trunk itself. This plexus supplies the œsophagus with *motor* power (p. 308), the *sensibility* which is present only in the upper part, and it also supplies fibres capable of exciting *reflex* actions.

10. The gastric plexus consists of (*a*) the anterior (left) termination of the vagus, which supplies fibres to the œsophagus and courses along the small curvature, and sends a few fibres through the portal fissure into the liver; (*b*) the posterior (right) vagus, after giving off a few fibres to the œsophagus, takes part in the formation of the gastric plexus, to which (*c*) *sympathetic* fibres are added at the pylorus. *Section of the vagi* is followed by hyperæmia of the gastric mucous membrane (Panum, Pincus), but it does not interfere with digestion (Bidder and Schmidt), even when it is performed at the cardia (Kritzler, Schiff—compare pp. 310, 329).

11. About two-thirds of the *right* vagus on the stomach joins the *cœliac* plexus, and from it branches accompany the arteries to the liver, spleen, pancreas, duodenum, kidney, and suprarenal capsules. The vagus supplies *motor* fibres to the stomach, which belong to the root of the vagus itself and not to the accessorius (Stilling, Bischoff, Chauveau—compare p. 310). The gastric branches also contain *afferent* fibres which, when stimulated, cause *reflexly* a *secretion of saliva* (p. 290).

It is undetermined whether they also cause vomiting. The effect of the *vagus* upon the movements of the intestine is discussed with the other nerves of the intestine at p. 319. According to some observers, stimulation of the *vagus* is followed by movements of the large as well as of the small intestine (Stilling, Kupffer, C. Ludwig, Remak). Stimulation of the *peripheral* end of the *vagus* causes contraction of the smooth muscular fibres in the capsule and trabeculæ of the *spleen* (in the rabbit and dog—p. 210). Stimulation of the *vagus* at the *cardia*, causes increase in the secretion of urine with dilatation of the *renal vessels*, while the blood of the renal vein becomes more arterial (Cl. Bernard). According to Rossbach and Quellhorst, a few *vaso-motor* fibres are supplied by the *vagus* to the abdominal organs, whilst the greatest number comes from the splanchnic. According to Ehl, *efferent* (centrifugal) *motor* fibres run in the *vagus* (dog) direct to the bladder, as well as *afferent* fibres whose stimulation causes reflex contraction of the *bladder*. So far, this observation has not been confirmed.

12. **Reflex Effects.**—The *vagus* and its branches contain fibres, some of which have been referred to already, which act *reflexly* (afferent) upon certain nervous mechanisms.

(a.) On the **vaso-motor centre** there act (a) *pressor* fibres (especially in both laryngeal nerves), whose stimulation is followed by a reflex contraction of the arterial blood-channels, and thus cause a rise of the blood-pressure; (β) *depressor* fibres (in the depressor or the *vagus* itself), which have exactly an opposite effect. (This subject is specially referred to under the head of the *Vaso-motor nerve-centre*, § 371.)

(b.) On the **respiratory centre** there act (a) fibres (pulmonary branches) whose stimulation is followed by *acceleration* of the respiration; and (β) *inhibitory* fibres (in both laryngeals), whose stimulation is followed by slowing or arrest of the respiration. (See *Respiratory centre*, § 368.)

(c.) On the **Cardio-inhibitory System**.—[When the *central* end of one *vagus* is stimulated, provided the other *vagus* is intact, the heart may be arrested *reflexly* in the diastolic phase]. Mayer and Pribram observed that sudden distension of the stomach caused slowing and even arrest of the heart, while, at the same time, there was contraction of the arteries of the medulla oblongata and increase of the blood-pressure.

(d.) On the **Vomiting Centre** (p. 311).—This centre may be affected by stimulation of the *central* end of the *vagus* and, as already mentioned, by stimulation of many afferent fibres in the *vagus*.

(e.) On the **Pancreatic Secretion** (p. 345).—Stimulation of the *central* end of the *vagus* is followed by arrest of this secretion.

(f.) According to Cl. Bernard, there are fibres present in the pulmonary nerves, which, when they are stimulated, increase reflexly the **formation of sugar in the liver**, perhaps through the hepatic branches of the *vagus*.

Unequal Excitability.—The various branches of the *vagus* are not all endowed with the same degree of *excitability*. If the *peripheral* end of the *vagus* be stimulated first of all with a weak stimulus, the laryngeal muscles are first affected, and afterwards the heart is slowed (Rutherford). If the *central* end be stimulated with feeble stimuli, the “*excito-respiratory*” fibres are exhausted before the “*inhibito-respiratory*” (Burkart). According to Steiner, the various fibres are so arranged

in the vagus that the afferent fibres lie in the outer, and the efferent in the inner, half of the trunk, in the cervical region.

Pathological.—Stimulation or paralysis in the area of the vagus must necessarily present a very different picture according as the affection is referred to the whole trunk or only to some of its branches, or whether the affection is unilateral or bilateral. **Paralysis of the pharynx and œsophagus**, which is usually of central or intracranial origin, interferes with or abolishes deglutition, so that when the œsophagus becomes filled with food, there is difficulty of breathing, and the food may even pass into the nasal cavities. A peculiar sonorous gurgling is occasionally heard in the relaxed canal (*deglutatio sonora*). In **incomplete paralysis**, the act of deglutition is delayed and rendered more difficult, while large masses are swallowed more easily than small ones.

Increased contraction and spasmodic stricture of the œsophagus are referred to under the phenomena of general nervous excitability (p. 380).

Spasm of the laryngeal muscles causes spasmodic closure of the glottis (*Spasmus glottidis*). This condition is most apt to occur in children, and takes place in paroxysms, with symptoms of dyspnoea and crowing inspiration; if the case be very severe, there may be muscular contractions (of the eye, jaw, digits, &c.). The symptoms are very probably due to the reflex spasms which may be discharged from the sensory nerves of several areas (teeth, intestine, skin). The impulse is conducted along the sensory nerves proceeding from these areas to the medulla oblongata, where it causes the discharge of the reflex mechanism which produces the above-mentioned results. There may be spasm of the dilators of the glottis (*Fräntzel*) and other laryngeal muscles.

Stimulation of the sensory nerves of the larynx, as is well known, produces **coughing**. If the stimulation be very intense, as in whooping-cough, the fibres lying in the laryngeal nerves, which *inhibit* the respiratory centre, may also be stimulated; the number of respirations is diminished, and ultimately the respiration ceases, the diaphragm being relaxed: while, with the most intense stimulation, there may be spasmodic expiratory arrest of the respiration with closure of the glottis, which may last for fifteen seconds. *Paralysis of the laryngeal nerves*, which causes disturbances of *speech*, has been referred to in § 313. In *bilateral paralysis of the recurrent nerves*, in consequence of tension upon them due to dilatation of the aorta and the subclavian artery, a considerable amount of air is breathed out, owing to the futile efforts which the patient makes in trying to speak; expectoration is more difficult, while violent coughing is impossible (v. Ziemssen). Attacks of dyspnoea occur just as in animals, if the person make violent efforts. Some observers (Salter, Bergson) have referred the **asthma nervosum** paroxysms, which last for a quarter of an hour or more, and constitute *asthma bronchiale*, to stimulation of the pulmonary plexus, causing spasmodic contraction of the bronchial muscle (p. 225). Physical investigation during the paroxysms reveals nothing but the existence of some rhonchi (p. 246). If this condition is really spasmodic in its nature (? of the vessels), it must be usually of a reflex character; the afferent nerves may be those of the lung, skin, or genitals (in hysteria). Perhaps, however, it is due to a temporary paralysis of the pulmonary nerves (afferent), which excite the respiratory centre (*excito-respiratory*).

Stimulation of the **cardiac** branches of the vagus may cause attacks of temporary suspension of the cardiac contractions, which are accompanied by a feeling of great depression and of impending dissolution, with occasionally, pain in the region of the heart. Attacks of this sort may be produced *reflexly*, e.g., by stimulation or irritation of the abdominal organs (as in the experiment of Goltz of tapping the intestines). Hennoch and Silbermann observed slowing of the action of the heart in children suffering from gastric irritation. Similarly, the respiration may be affected reflexly through the vagus, a condition described by Hennoch as *asthma dyspepticum*. In cases of intermittent

paralysis of the cardiac branches of the vagus, we rarely find *acceleration* of the pulse above 160 (Riegel), 200 (Tuczek, L. Langer, Weil); even 240 pulse-beats per minute have been recorded (Kuppert), and in such cases the beats vary much in rhythm and force, and they are very irregular. These cases require to be more minutely analysed, as it is not clear how much is due to paralysis of the vagus and how much to the action of the accelerating mechanism of the heart. Little is known of affections of the *intra-abdominal* fibres of the vagus. It seems that the sensory branches of the stomach do not come from the vagus.

If the trunk of the vagus or its centre be paralysed, there are laboured, deep, slow respirations, such as follow the section of both vagi (Guttman).

353. XI. Nervus Accessorius Willisii.

Anatomical.—This nerve arises by two completely separate roots; *one* from the *accessorius* nucleus of the *medulla oblongata* (Fig. in § 366), which is connected with the vagus nucleus; while the *other* root arises between the anterior and posterior nerve roots from the *spinal cord*, usually between the 5th and 6th cervical vertebræ. In the interior of the spinal cord, its fibres can be traced to an elongated nucleus lying on the outer side of the anterior cornu, as far downwards as the 5th cervical vertebra. Near the jugular foramen, both portions come together, but do not exchange fibres (Holl); both roots afterwards separate from each other to form two distinct branches, the *anterior (inner)*, which arises from the medulla oblongata passing *en masse* into the plexus gangliiformis vagi. This branch supplies the vagus with most of its *motor* fibres (compare § 352, 3), and also its *cardio-inhibitory* fibres. If the *accessorius* be pulled out by the root in animals, these heart-fibres undergo degeneration. If the trunk of the vagus be stimulated in the neck 4–5 days after the operation, the action of the heart is no longer arrested thereby [owing to the degeneration of the cardio-inhibitory fibres] (Waller, Schiff, Daszkiewicz, Heidenhain); according to Heidenhain, the heart-beats are accelerated immediately after pulling out the nerve.

The *external* branch arises from the spinal roots. This nerve communicates with the *sensory* branches of the posterior root of the first, more rarely of the second cervical nerve, and these fibres supply sensibility to the muscles; it then turns backwards above the transverse process of the atlas, and terminates as a *motor* nerve in the sternomastoid and trapezius (Galen, Valentin, Volkmann). The latter muscle usually receives motor fibres also from the cervical plexus (Fig. 323).

The *external* branch communicates with several cervical nerves. These fibres either participate in the innervation of the above-named muscles, or the *accessorius* returns part of the sensory fibres supplied by the posterior roots of the two upper cervical nerves.

Pathological.—*Stimulation* of the *outer* branch causes tonic or clonic spasm of the above-named muscles, usually on one side. If the branch to the sternomastoid be affected alone, the head is moved with each clonic spasm. If the affection be bilateral, the spasm usually takes place on opposite sides alternately, while it is rare to have it on both sides simultaneously. In *spasm of the trapezius*, the head is drawn backwards and to the side.

Tonic contraction of the flexors of the head causes the characteristic position of the head known as *caput obstipum* (spasticum) or wry-neck.

In *paralysis* of one of these muscles, the head is drawn towards the sound side (*torticollis paralyticus*). Paralysis of the trapezius is usually only partial.

Paralysis of the whole trunk of the spinal accessory, (usually caused by central conditions), besides causing paralysis of the sternomastoid and trapezius, also paralyses the motor branches of the vagus already referred to (Erb, Fränkel, Holz).

354. XII. Nervus Hypoglossus.

Anatomical.—It arises from two *large-celled* nuclei within the lowest part of the calamus scriptorius, and one adjoining *small-celled* nucleus (Roller), while additional fibres come from the brain (§ 378), and also perhaps from the olive. It springs by 10–15 twigs in a line with the anterior roots of the spinal nerves (Fig. 321, 1X). In its development, part of the hypoglossal behaves as a spinal nerve (Froriep).

Function.—It is *motor to all the muscles of the tongue*, including the geniohyoid and thyrohyoid.

Connections.—The trunk of the hypoglossal is connected with: (1) The *superior cervical ganglion* of the *sympathetic*, which supplies it with *vaso-motor* fibres for the blood-vessels of the tongue. After section of the hypoglossal and lingual nerves, the corresponding half of the tongue becomes red and congested (Schiff). (2) There is also a branch from the plexus gangliiformis vagi, its small lingual branch to the commencement of the hypoglossal arch. These fibres supply the hypoglossal with *sensory* fibres for the *muscles of the tongue*, for even after section of the lingual, the tongue still possesses dull sensibility. It is uncertain whether fibres with a similar function are partly derived from the cervical nerves or from the anastomosis which takes place with the lingual. (3) It is united with the *upper cervical nerves* by means of the loops known as the *ansa hypoglossi*. These connecting fibres run in the *descendens noni* to the sternohyoid, omohyoid, and sternothyroid. Cervical fibres do not, as a rule, enter the tongue; stimulation of the root of the hypoglossal acts upon the above-named muscles only very rarely and to a very slight extent (Volkmann). Compare § 297, 3, and § 336, III.

Bilateral section of the nerve causes complete motor paralysis of the tongue. Dogs can no longer lap, they bite the flaccid tongue. Frogs, which seize their prey with the tongue, must starve; when the tongue hangs from the mouth, it must prevent the closure of the mouth, so that these animals must die from asphyxia, as air is pumped into the lungs only when the mouth is closed.

Pathological.—*Paralysis* of the hypoglossal (*glossoplegia*), which is usually central in its origin, causes disturbance of *speech* (p. 706). For the deviation of the tongue in unilateral paralysis, see p. 305. Paralysis of the tongue also interferes with mastication, the formation of the bolus in the mouth, and deglutition in the mouth. Owing to the imperfect movements of the tongue, *taste* is imperfect, and the singing of high notes and the falsetto voice, which require certain positions of the tongue, appear to be impossible (Bennati).

Spasm of the tongue, which causes aphthongia (p. 705), is usually reflex in its

origin, and is extremely rare. Idiopathic cases of spasm of the tongue have been described; the seat of the irritation lay either in the cortex cerebri or in the oblongata (Berger, E. Remak).

355. The Spinal Nerves.

Anatomical.—The 31 pairs of spinal nerves arise by means of a **posterior root**, (consisting of a few large rounded bundles), from the sulcus between the posterior and lateral columns of the spinal cord, and by means of an **anterior root**, (consisting of numerous fine flat strands), from the furrow between the anterior and lateral columns. The posterior roots, with the exception of the first cervical nerve, are the larger. Occasionally the roots on opposite sides are not symmetrical; one or other root, or even a whole nerve, may be absent from the dorsal region (Adamkiewicz).

On the *posterior root* is the spindle-shaped **spinal ganglion** (§ 321, II, 3), which is occasionally double on the lumbar and sacral nerves (Davida). *Beyond the ganglion*, the two roots unite to form within the spinal canal the mixed trunk of a **spinal nerve**. The branches of the nerve-trunk invariably contain fibres coming from both roots. The number of fibres in the nerve-trunk is exactly the same as in the two roots; hence, we must conclude that the nerve-cells in the spinal ganglion are intercalated in the course of the fibres (Gaule and Birge).

[Structure of a Spinal Ganglion.—The ganglion is invested by a thin, firmly adherent, sheath of connective-tissue, which sends processes into the swelling, and is continuous with the sheaths of the nerve entering and leaving the ganglion. A longitudinal section of such a ganglion exhibits the cells arranged in groups, with strands of nerve-fibres coursing longitudinally between them. The nerve-cells are usually globular in form, with a distinct capsule lined with epithelium, and the cell-substance itself contains a well-defined nucleus with a nuclear envelope and a nucleolus. The capsule is continuous with the sheath of Schwann of a nerve-fibre. The exact relation between the nerve-fibres, and the nerve-cells is difficult to establish, but it is probable that each nerve-cell is connected with a nerve-fibre. In the spinal ganglia of the vertebrates above fishes, and also in the Gasserian ganglion (Fig. 327) cells are found with a single process or fibre attached to them, the nerve-fibre process not unfrequently coiling a few times within the capsule. This process, after emerging from the capsule, becomes coated with myelin, and usually soon divides at a node of Ranvier (Fig. 327, *t*). Ranvier, who first observed this arrangement, described it as a T-shaped fibre. These nerve-cells with T-shaped fibres have been observed in the spinal ganglia of all vertebrates above fishes, in the Gasserian (Fig. 277, II), and geniculate ganglia, as well as in the jugular and *cervical* ganglia of the vagus. In *fishes*, the nerve-cells of the spinal ganglia are bipolar (Fig. 277, 4).]

Bell's Law.—Sir Charles Bell discovered (1811) that the *anterior* roots of the spinal nerves are *motor*, the *posterior* are *sensory*.

Recurrent Sensibility.—Magendie discovered (1822) the remarkable fact, that *sensory fibres are also present* in the anterior roots, so that their stimulation causes pain. This is due to the fact, that sensory fibres pass into the anterior root after the two roots have joined, and

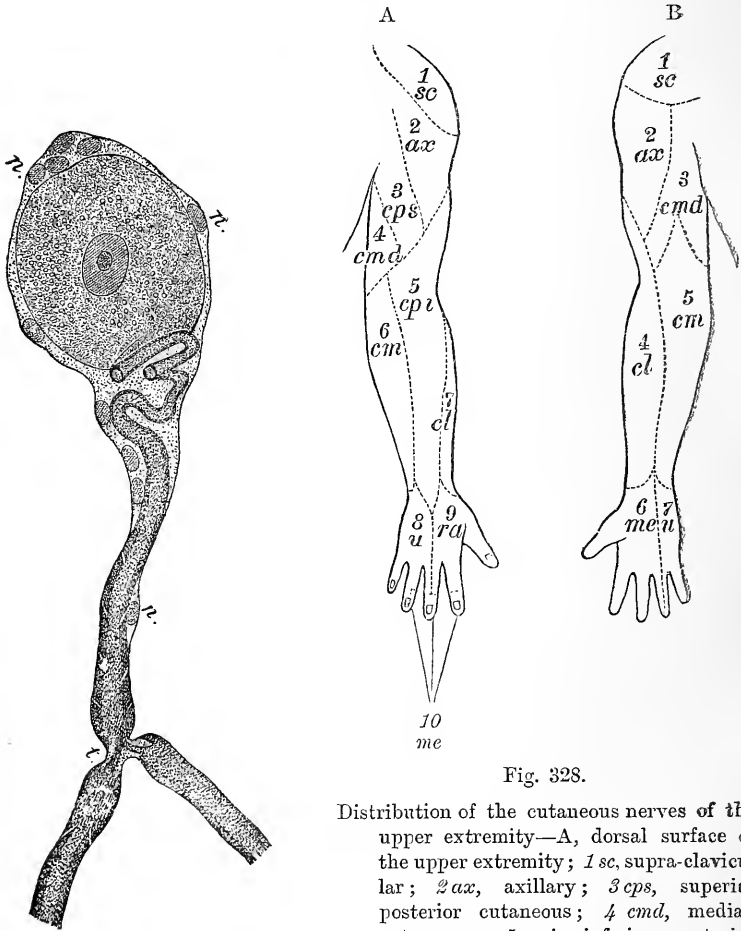

Fig. 327.

Nerve-cell from the Gasserian ganglion.

Fig. 328.

Distribution of the cutaneous nerves of the upper extremity—A, dorsal surface of the upper extremity; 1 *sc*, supra-clavicular; 2 *ax*, axillary; 3 *cps*, superior posterior cutaneous; 4 *cmd*, median cutaneous; 5 *cpi*, inferior posterior cutaneous; 6 *cm*, median cutaneous; 7 *cl*, lateral cutaneous; 8 *u*, ulnar; 9 *ra*, radial; 10 *me*, median. B, volar surface of the upper limb; 1 *sc*, supra-clavicular; 2 *ax*, axillary; 3 *cmd*, internal cutaneous; 4 *cl*, lateral cutaneous; 5 *cm*, cutaneous medius; 6 *me*, median; 7 *u*, ulnar.

these fibres run in the anterior root in a centripetal direction (Schiff, Cl. Bernard). The sensibility of the anterior root is abolished at once

by section of the posterior root. This condition is called "recurrent sensibility" of the anterior root. When the sensibility of the anterior root is abolished, so is the sensibility of the surface of the spinal cord in the neighbourhood of the root. A long time after section of the anterior, and when the degeneration phenomena have had time to develop (§ 325), a few non-degenerated sensory fibres are always to be found in the central stump (Schiff, Vulpian). Schiff found that in cases where the motor fibres had undergone degeneration, there were always non-degenerated fibres to be found in the anterior root, which passed into the membranes of the spinal cord. The sensory fibres pass into the motor root either at the angle of union of the roots, or in the plexus, or in the region of the peripheral terminations. Sensory fibres enter many of the branches of the motor cranial nerves at their periphery, and afterwards run in a centripetal direction (p. 807). Even into the trunks of *sensory* nerves, sensory branches of other sensory nerves may enter. This explains the remarkable observation, that after section of a nerve trunk (*e.g.*, the median), its peripheral terminations still retain their sensibility (Arloing and Tripier). The tissue of the motor and sensory nerves, like most other tissues of the body, is provided with sensory nerves (*Nervi nervorum*, p. 716).

Relative Position of Motor and Sensory Fibres.—In embryos (rabbit), the motor fibres stain more deeply with carmine than the sensory fibres, so that their position in the peripheral nerves of distribution may thereby be made out. In the *anterior branch* of a spinal nerve, the sensory fibres lie in the outer part of the branch, the motor in the inner part; while this relation is reversed in the posterior root (L. Löwe).

Deductions from Bell's Law.—Careful observation of the effects of section of the roots of the spinal nerves (Magendie, 1822), as well as the discovery of the reflex relation of the stimulation of the sensory roots to the anterior, constituting reflex movements (Marshall Hall, Johannes Muller, 1832), enable us to deduce the following conclusions from Bell's law:—1. At the moment of section of the **anterior root**, there is a *contraction* in the muscles supplied by this root. 2. There is at the same time a *sensation of pain* due to the "recurrent sensibility." 3. After the section, the corresponding *muscles* are *paralysed*. 4. Stimulation of the peripheral trunk of the anterior root (immediately after the operation) causes *contraction* of the muscles, and eventually pain, owing to the recurrent sensibility. 5. Stimulation of the central end is *without effect*. 6. The peripheral end of the motor nerves degenerate within a short time (§ 325, 4). 7. The central end degenerates somewhat later (§ 325, 3). 8. The sensibility of the paralysed parts is retained completely. 9. At the moment of section of the **posterior root**, there is severe *pain*. 10. At the same

time, movements are discharged reflexly. 11. After the section, all parts supplied by the divided roots are devoid of sensibility. 12. Stimulation of the peripheral trunk of the divided nerve is without effect. 13. Stimulation of the central end causes *pain* and *reflex* movements. 14. With reference to the degeneration of the peripheral end of the sensory fibres—see § 325, 4. 15. The central end ultimately degenerates. 16. Movement is retained completely in the paralysed parts (*e.g.*, in the extremities).

Unco-ordinated Movements of Insensible Limbs.—After section of the posterior roots (*e.g.*, of the nerves for the posterior extremities), the muscles retain their movements, nevertheless there are characteristic disturbances of their motor power. This is expressed in the awkward manner in which the animal executes its movements—it has lost to a large extent its harmony and elegance of motion. This is due to the fact, that, owing to the absence of the sensibility of the muscles and skin, the animal is no longer conscious of the resistance which is opposed to its movements. Hence, the degree of muscular energy necessary for any particular effort cannot be accurately graduated. Animals which have lost the sensibility of their extremities, often allow their limbs to lie in abnormal positions, such as a healthy animal would not tolerate. In man also, when the peripheral ends of the cutaneous nerves are degenerated, there are *ataxic* phenomena (§ 364, 3).

Harless (1858), Ludwig, and Cyon (controverted by v. Bezold, Uspensky, Grünhagen, and G. Heidenhain) observed that the anterior root is more excitable as long as the posterior roots remain intact and are sensitive, and that their excitability is diminished as soon as the posterior roots are divided. In order to explain this phenomenon, we must assume that in the intact body, a series of gentle impulses (impressions of touch, temperature, position of limbs, &c.) are continuously streaming through the posterior roots to the spinal cord, where they are transferred to the motor roots, so that a less stimulus is required to excite the anterior roots, than when these reflex impulses of the posterior root, which increase the excitability, are absent. Clearly, a less stimulus will be required to excite a nerve already in a gentle state of excitement than in the case of a fibre which is not so excited. In the former case, the discharging stimulus becomes as it were superposed on the excitement already present. (Compare § 362.)

The anterior roots of the spinal nerves supply *effere*nt fibres to—

1. All the voluntary muscles of the trunk and extremities.

Every muscle always receives its motor fibres from *several* anterior roots, (not from a single nerve-root). Hence, *every* root supplies branches to a particular group of muscles (Preyer, P. Bert, Gad). The experiments of Ferrier and Yeo show that stimulation of each of the anterior roots in apes (brachial and lumbo-sacral plexuses) caused a complex co-ordinated movement. Section of one root did not cause complete paralysis of the muscles concerned in these co-ordinated movements, although the force of the movement was impaired. These experiments confirm the results of clinical observation on man. The fibres for groups of muscles of different functions (*e.g.*, for flexors, extensors) arise from special limited areas of the spinal cord. The cervical and lumbar enlargements of the spinal cord are great centres for highly co-ordinated muscular movements.

2. The anterior roots also supply motor fibres for a number of organs provided with smooth muscular fibres, *e.g.*, the bladder (§ 280), ureter, uterus.

3. Motor fibres for the smooth muscular fibres of the *blood-vessels*, the *vaso-motor*, *vaso-constrictor*, or *vaso-hypertonic* nerves. They run in the sympathetic for a part of their course. (See § 371.)

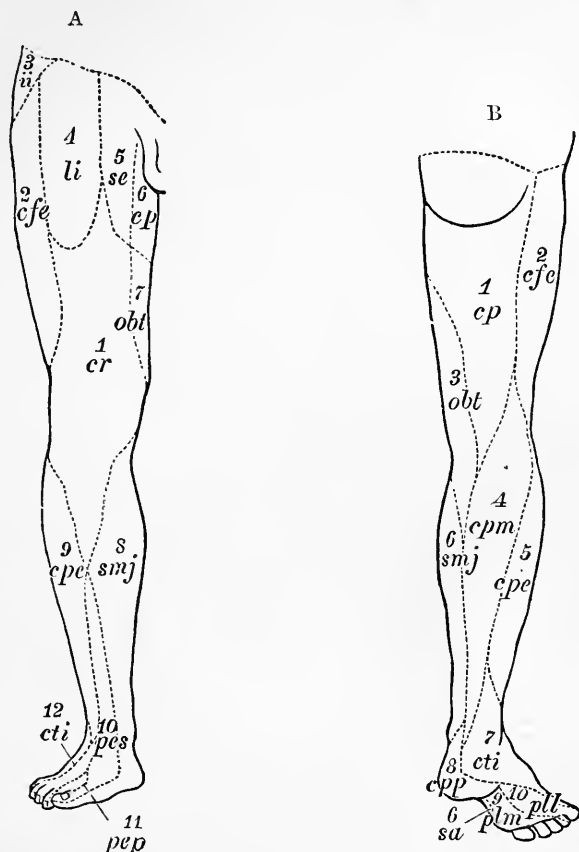

Fig. 329.

Distribution of the cutaneous nerves of the leg (after Henle).

- A, Anterior Surface—1, crural nerve; 2, external lateral cutaneous; 3, ilio-inguinal; 4, lumbo-inguinal; 5, external spermatic; 6, posterior cutaneous; 7, obturator; 8, great saphenous; 9, communicating peroneal; 10, superficial peroneal; 11, deep peroneal; 12, communicating tibial.
- B, Posterior Surface—1, posterior cutaneous; 2, external femoral cutaneous; 3, obturator; 4, median posterior femoral cutaneous; 5, communicating peroneal; 6, great saphenous; 7, communicating tibial; 8, plantar cutaneous; 9, median plantar; 10, lateral plantar.

4. Inhibitory fibres for the blood-vessels. These are but imperfectly known. They are also called *vaso-dilator* or *vaso-hypotonic* nerves. (See § 372.)

5. Secretory fibres for the sweat-glands of the skin (§ 289). For a part of their course they run in the sympathetic.

6. The trophic fibres of the tissues (§ 342, I., c).

The posterior roots contain all the sensory nerves of the whole of the skin and the internal tissues, except the front part of the head, face, and the internal part of the head (see *Cranial nerves*). They also contain the tactile nerves for the areas of the skin already mentioned. Stimuli which discharge *reflex movements* are conducted to the spinal cord through the posterior roots. The sensory fibres of a mixed nerve-trunk supply the cutaneous area, which is moved by those muscles (or which covers those muscles—Preyer) to which the same branch supplies the motor fibres (Schröder van der Kolk). The special distribution of the motor and sensory nerves of the body belongs to anatomy.

The distribution of the cutaneous nerves of the limbs is given in Figs. 328 and 329, while Figs. 323, 324 show those of the head.

356. The Sympathetic Nerve.

Anatomical.—The sympathetic nervous system, which contains a very large number of non-medullated or Remak's nerve-fibres, consists of a double gangliated pre-vertebral cord, one lying on each side of the vertebral column. Each spinal nerve gives off a *ramus communicans* into the sympathetic cord on its own side; and the sympathetic is provided with a ganglion where the communicating branch joins it. The four upper rami communicantes from the four upper cervical nerves all join the superior cervical ganglion (Fig. 322, *Gg*, s), the fifth and sixth join the middle cervical, the seventh and eighth the inferior cervical ganglion. The lowest pair of ganglia are generally united by a loop on the front of the first coccygeal vertebra, and they lie in relation with the coccygeal ganglion.

The **rami communicantes** (which connect the sympathetic cord with the spinal nerves) proceed from the *spinal cord*, partly by the anterior, and partly by the posterior spinal roots (§ 355).

Cephalic Portion.—As the sympathetic ascends to the head, it forms connections with many of the cranial nerves, and there is a free exchange of fibres between these nerves. (The function and significance of these exchanges are referred to under the physiology of the cranial nerves.)

Dorsal and Abdominal Portion.—Numerous fibres pass from these parts chiefly to the *thoracic* and *abdominal cavities*, where they form large gangliated plexuses, from which functionally different fibres proceed to the different organs.

[Structure of a Ganglion.—The structure of the sympathetic nerve-fibres and nerve-cells has already been described in § 321. On making a section of a sympathetic ganglion—*e.g.*, the human superior cervical, we observe groups of cells with bundles of nerve-fibres—chiefly non-medullated—running between them, and the whole surrounded by a laminated capsule of connective-tissue, which sends septa into the ganglion. The *nerve-cells* have many processes, and are, therefore, multipolar, and each cell is surrounded by a capsule with nuclei on its inner surface (Fig. 277, II). The processes pierce the capsule, and one of them certainly—and perhaps all the processes—are connected with a nerve-fibre. Not unfrequently yellowish-brown pigment is found in the cell-substance. Similar

cells have been found in the ophthalmic, sub-maxillary, otic, and sphenopalatine ganglia.]

Functions.—The following is merely a *general* summary:—

I. Independent Functions of the sympathetic are those of certain nerve plexuses which remain after all the nervous connections with the cerebro-spinal branches have been divided.

To these belong:—

1. The automatic ganglia of the heart (§ 58).
2. The mesenteric plexus of the intestine (§ 161).
3. The plexuses of the uterus, Fallopian tubes, ureters, also of the blood- and lymph-vessels.

The activities of these plexuses may be influenced—either in the direction of inhibition or stimulation—through fibres reaching them from the cerebro-spinal nerves.

II. Dependent Functions.—Fibres run in the sympathetic, which (like the peripheral nerves), are active only when their connection with the central nervous system is maintained—*e.g.*, the sensory fibres of the splanchnic. Others again convey impulses from the central nervous system to the *ganglia*, while the ganglia in turn modify the impulses which inhibit or excite the movements of the corresponding organs.

The following statement is a *resumé* of the functions of the sympathetic, according to the anatomical arrangement:—

A. Cervical Part of the Sympathetic.

1. **Pupil-dilating fibres** (compare *Ciliary ganglion*, § 347, I., and *Iris*, § 392). According to Budge, these fibres arise from the spinal cord and run through the upper two dorsal and lowest two cervical nerves into the cervical sympathetic, which conveys them to the head. Section of the cervical sympathetic or its rami communicantes causes contraction of the pupil. (The central origin of these fibres is referred to in § 362, 1, and § 367, 8).

2. **Motor fibres** for Müller's smooth muscle of the orbit, and *partly* for the external rectus muscle (§ 348).

3. **Vaso-motor branches** for the outer ear and the side of the face (Cl. Bernard), tympanum (Prussak), conjunctiva, iris, choroid, retina (*only in part*—see *Ciliary ganglion*, § 347, I.), for the vessels of the œsophagus, larynx, thyroid gland—fibres for the vessels of the brain and its membranes (Donders and Callenfels); but, according to Nothnagel, fibres also arise from the cranial nerves, which form connections with the carotid plexus.

4. **Secretory, (trophic), and vaso-motor fibres** for the salivary glands (§ 145).

5. **Sweat-secretory fibres**—see § 288, II.

6. According to Wolferz and Demtschenko, the lachrymal glands receive sympathetic secretory fibres (?).

B. Thoracic and Abdominal Parts of the Sympathetic.

First of all there is: 1. The sympathetic portion of the cardiac plexus (§ 57, 2), which receives *accelerating* fibres for the heart from the lower cervical and first thoracic ganglion (Cl. Bernard, v. Bezold, Cyon, Schmiedeberg). The fibres arise partly from the sympathetic and partly from the plexus around the vertebral artery (v. Bezold, Bever). Compare § 370.

2. The cervical sympathetic and the splanchnic contain fibres which, when their central ends are stimulated, excite the **cardio-inhibitory system** in the medulla oblongata (Bernstein).

3. The cervical sympathetic contains afferent fibres which, when stimulated, excite the **vaso-motor centre** in the medulla oblongata (Aubert).

4. The functions of the splanchnic are referred to in § 164, § 175, § 276, and § 371.

5. The functions of the **cœliac and mesenteric plexuses** are referred to in § 183 and § 192. After extirpation of the cœliac ganglion, Lamansky observed temporary disturbance of digestion, undigested food being passed per anum.

6. For the **secretory fibres for sweating**, see § 289, II.

7. Lastly, the abdominal portion of the sympathetic contains **motor and vaso-motor fibres** for the *spleen*, the *large intestine* (accompanying its arteries), *bladder* (§ 280), *ureters*, *uterus* (running in the hypogastric plexus), *vas deferens*, and *vesiculæ seminales*. *Stimulation* of all of these nerve channels causes increased movement of the organs, but it must be remembered, that the diminished supply of blood thereby produced also acts as a stimulus (p. 318). *Section* of these nerves is followed by dilatation of the blood-vessels, with subsequent derangement of the circulation, and ultimately of the nutrition. The relation of the **supra-renal bodies** to the sympathetic is referred to in § 103, IV. The **renal plexus** is referred to in § 276, while the **cavernous plexus** is treated of in § 436.

Pathological.—Considering the numerous connections of the sympathetic, we would naturally suppose that it offers an extensive area for pathological changes. It is to be observed that all affections involving the vaso-motor system are referred to in § 371.

The **cervical sympathetic** is most frequently paralysed or stimulated by traumatic conditions, wounds by bullets or knives, tumours, enlarged lymph-glands, aneurisms, inflammation of the apices of the lungs and the adjacent pleuræ, while exostoses of the vertebræ may stimulate it in part or paralyse it in part. The phenomena so produced have been partly analysed in treating of the ciliary ganglion (§ 347, I). **Stimulation of the cervical sympathetic** in man, causes dilatation of the pupil (*mydriasis spastica*), palor of the face, and occasionally hyperidrosis or profuse sweating (§ 289, 2, and § 288); disturbance of vision for near objects, as the pupil cannot be contracted (see *Accommodation*), and hence the spherical aberration of the lens (§ 391) must also interfere with vision; protrusion of the eyeball with widening of the palpebral fissure. **Paralysis or section of the cervical sympathetic** causes increased fulness of the blood-vessels of the side of the head, with occasional anidrosis. Contraction of the pupil (*myosis paralytica*), which undergoes changes in its diameter during accommodation, but not as the effect of the stimulation of light—atropin dilates it slightly. The slit between the eyelids is narrowed, the eyeball retracted and sunk in the orbit, the cornea somewhat flattened, and the consistence of the eyeball diminished. Stimulation of the sympathetic is followed by an *increased secretion of saliva* (§ 145). The above described symptoms have been occasionally accompanied by *unilateral atrophy of the face*.

[Section of the Cervical Sympathetic.—This experiment is easily done on a rabbit, preferably an albino one. Divide the nerve in the neck, and immediately thereafter (1) the ear and adjoining parts on that side become greatly congested with blood, blood-vessels appear that were formerly not visible, and as a result of the increased quantity of blood in the ear (hyperæmia), there is (2) a rise of the temperature amounting to even 4°–6°C. (Cl. Bernard). These are the *vaso-motor* changes. (3) The pupil is contracted, the cornea flattened, and there is retraction of the eyeball and consequent narrowing of the palpebral fissure. These are the *oculo-pupillary* symptoms. **Stimulation** (electrical) of the peripheral end produces the opposite results,—pallor of the ears, owing to contraction of the blood-vessels, with consequent fall of the temperature; dilatation of the pupil, bulging of the cornea, protrusion of the eyeball (*exophthalmos*), and widening of the palpebral fissure. At the same time, the blood-vessels to the salivary glands are contracted, and there is a secretion of *thick* saliva. The last results are the *trophic and secretory* fibres. The vaso-motor and oculo-pupillary fibres, although they lie in the same trunk in the neck, do not issue from the cord by the same nerve roots, the latter come out of the cord with the anterior roots of the first and second dorsal nerves (dog), while section of the cord between the second and fourth dorsal vertebræ produces the vaso-motor changes only. The nasal mucous membrane and lachrymal gland are influenced by the sympathetic.]

[Division of the cervical sympathetic in young *growing* animals results in hypertrophy of the ear, and increased growth of the hair on that side (Bidder, W. Stirling).]

Irritation in the area of the splanchnic, as occurs occasionally in lead poisoning, is characterised by violent pain (lead colic), inhibition of the intestinal movements

(hence, the persistent constipation), slowing of the heart's action, brought about reflexly, just as in Goltz's "tapping" experiment. Irritation in the area of the sensory nerves of the sympathetic may give rise to that condition which is called by Romberg *neurralgia hypogastrica*, a painful affection of the lower abdominal and sacral regions, *hysteralgia*, *neurralgia testis*, which are localised in the plexuses of the sympathetic. In affections of the *abdominal sympathetic*, there may be severe constipation, with diminished or increased secretion of the intestinal glands (§ 186).

357. Comparative—Historical.

Comparative.—Some of the **cranial nerves** may be absent, others, again, may be abortive, or exist as branches of other nerves. The facial nerve, which supplies the muscles of expression in man, and is, at the same time, the nerve for facial respiratory movements, diminishes more and more in the lower classes of the vertebrata, *pari passu*, with the diminution of the facial muscles. In **birds** and **reptiles**, it supplies the muscles of the hyoid bone, or the superficial cervical muscles of the nape of the neck. In **amphibians** (frog), the facial no longer exists as a separate nerve, the nerve which corresponds to it springing from the trigeminus. In **fishes**, the 5th and 7th nerves form a joint complex nerve. The part corresponding to the facial (also called *ramus opercularis trigemini*) is the chief motor nerve of the muscles of the gill-cover, and is, therefore, the respiratory nerve. In the cyclostomata (lamprey), there is an independent facial. The *vagus* is present in all vertebrata; in fishes it gives off a large nerve, the *lateral nerve* of the body (*N. lateralis*), which runs along each side of the body close to the lateral canal. It is also present in the tadpole. Its rudimentary representative in man is the auricular branch. In the frog, the 9th, 10th, and 11th arise together from one trunk, and the 7th and 8th from another. In fishes and amphibia, the hypoglossal is the first cervical nerve. In amphioxus, the cerebral and spinal nerves are not distinct from each other. The **spinal nerves** are remarkably similar in all class of the vertebrata. The **sympathetic** is absent in the cyclostomata, where it is represented by the *vagus*. Its course is along the vertebral column, where it receives the *rami communicantes* of the spinal nerves. In the region of the head, its connections with the 5th and 10th nerves are specially developed. In frogs, and still more so in birds, the number of connections with the cranial nerves increases.

Historical.—The *vagus* and sympathetic were known to the Hippocratic School. According to Erasistratus, all the nerves proceed from the brain and spinal cord; Herophilus was the first to distinguish the nerves from the tendons, which Aristotle confounded with each other. Marianus (80 A.D.) recognised seven pairs of cranial nerves. Galen was in possession of a wide range of important facts in the physiology of the nervous system (§ 140); he observed that loss of voice followed ligature of the recurrent nerves; and he was acquainted with the *accessorius*, and the ganglia on the abdominal nerves. The *cauda equina* is referred to in the Talmud; Coiter (1573) described exactly the anterior and posterior spinal nerve roots. Van Helmont († 1644) states that the peripheral motor nerves also give rise to impressions of pain, and Cesalpinus (1571) remarks that interruption of the blood-stream makes the parts insensible. Thomas Willis described the chief ganglia (1664). In Des Cartes there is the first indication of reflex movements; Stephen Hales and Robert Whytt showed that the spinal cord was necessary for such acts. Prochaska described the reflex channels, [while Marshall Hall established the doctrine of reflex, or, as he called them, "diastaltic" actions]. Duverney (1761) discovered the ciliary ganglion. Gall traced more carefully the course of the 3rd and 6th nerves, and also the spinal nerves into the grey matter. Hitherto only nine nerves of the brain had been enumerated; Sömmerring separated the facial from the auditory nerve, Andersch the 9th, 10th and 11th nerves.

Physiology of the Nerve Centres.

358. General.

General Functions.—The central organs of the nervous system are in general characterised by the following properties:—

1. They contain **nerve-cells**, which are either arranged in groups in the interior of the central organs of the nervous system, or embedded in the peripheral branches of the nerves.

2. The nerve centres are capable of discharging **reflexes**; *e.g.*, reflex-motor, reflex-secretory, and reflex-inhibitory acts.

3. The centres may be the seat of **automatic excitement**, *i.e.*, they may manifest phenomena, without the application of any *apparent* external stimulus. The energy so liberated may be transferred to act upon other organs. This automatic state of excitement or stimulation may be *continuous*, *i.e.*, may be continued without interruption, when it is called **tonic automatic** or **tonus**; or it may be *intermittent*, and occur with a certain rhythm (*rhythmical automatic*).

4. The central organs are **trophic centres** for the nerves proceeding from them; they may also perform similar functions for the tissues innervated by them.

5. The **psychical activities** are dependent upon an intact condition of the ganglionic central organs.

As a single momentary stimulus (*e.g.*, an opening induction shock, or a puncture of a transverse section of the spinal cord), may produce a longer *tetanus*, whilst the same stimulus, if applied to the motor nerves, causes only a *single contraction*, it seems as if the central nervous system possessed the property of transforming an instantaneous stimulus into a long-continued state of stimulation (R. Marchand). The organs causing the continued movement, are the ganglionic cells of the anterior horn of the spinal cord (Birke).

These various functions are distributed over different centres, and no centre seems to perform more than one function.

The Spinal Cord.

359. Structure of the Spinal Cord.

Structure.—The spinal cord consists of white matter externally, and grey matter internally. The *grey matter* has the form of two crescents)-(placed

back to back, [or a capital H], in which we can distinguish an *anterior* (*a*) and a *posterior* horn (*p*), and a middle part, or *grey commissure* connecting the two crescents. In the centre of this grey commissure is a canal—*central canal*—which runs from the *calamus scriptorius* downwards; it is lined throughout by a single layer of ciliated cylindrical epithelium [in the fetus, the cilia being absent in the adult], and the canal itself is the representative of the embryonal “medullary tube.” [The part of the grey commissure in front of this canal is called the *anterior*, and the part behind, the *posterior* grey commissure.]

[In front of the grey commissure, and between it and the base of the anterior median fissure, are bundles of white nerve-fibres passing in a horizontal or oblique direction from the anterior column of one side, to the grey matter of the anterior cornu of the opposite side (Fig. 330). These decussating fibres constitute the *white commissure*.]

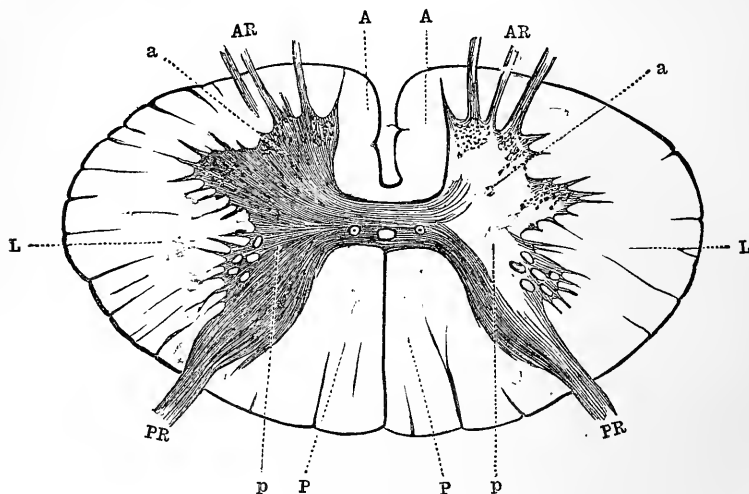

Fig. 330.

Transverse section of the spinal cord; in the centre is the butterfly form of the grey matter surrounded by the white matter—*p*, posterior, and *a*, anterior horns of the grey matter; *PR*, the posterior roots; *AR*, the anterior roots of the spinal nerves; *A, A*, the white anterior columns; *L, L*, the lateral columns; *P, P*, the posterior columns.

The **white matter** surrounds the grey, and is arranged in several *columns*. Along the anterior surface of the cord, there runs a well-marked fissure, which dips into the cord itself, but does not reach the grey matter, as a mass of white matter—the *white commissure*—runs from one side of the cord to the other. Between this fissure, known as the *anterior median fissure*, and the line of exit of the anterior roots of the spinal nerves, lies the *anterior column* (*A*); the white matter lying laterally between the origin of the anterior and posterior roots of the spinal nerves is the *lateral column* (*L*), while the white matter lying between the line of origin of the posterior roots and the so-called *posterior median fissure* is the *posterior column* (*P*). [The posterior median fissure is not a real fissure, but is filled up with a layer of the pia mater, which dips down from the under surface of this membrane quite to the grey matter of the posterior commissure]. Each posterior column, in certain regions of the cord, may be subdivided into an inner part lying

next the fissure, the *Postero-median* or *Goll's column*, or the *inner root-zone* (Charcot—Fig. 335, c); and an outer larger part next the posterior root, known as the *postero-external* or *Burdach's column*, or the *outer root-zone* (Charcot—Fig. 335, d).

The **white matter** consists chiefly of medullated fibres without the sheath of Schwann and Ranvier's nodes, but provided with the neuro-keratin sheaths of Kühne and Ewald (p. 714), the fibres themselves being chiefly arranged *longitudinally*. The nerve-fibres of the nerve-roots, as well as those that pass from the grey matter into the columns, have a transverse or oblique course. There are also decussating fibres in the anterior or white commissure. [In a transverse section of the white matter of the spinal cord, the nerve-fibres are of different sizes, and appear like small circles with a rounded dot in their centre—the axis cylinder—the latter may be stained with carmine or other dye. The white substance of Schwann, especially in preparations hardened in salts of chromium, often presents the appearance of concentric lines. Fine septa of connective-tissue carrying blood-vessels lie between groups of the nerve-fibres, while here and there between the nerve-fibres may be seen branched neuroglia corpuscles. Immediately underneath the pia matter, there is a pretty thick layer of neuroglia, which invests the prolongations of the pia into the cord.]

[The **grey matter** differs in shape in the different regions of the cord, and so does the grey commissure (Fig. 332). The latter is thicker and shorter in the cervical than in the dorsal region, while it is very narrow in the lumbar region. The amount of grey matter undergoes a great increase opposite the origins of the large nerves, the increase being most marked opposite the cervical and lumbar enlargements. Ludwig and Woroschiloff constructed a series of curves from measurements by Stilling of the sectional areas of the grey and white matter of the cord, as well as of the several nerve-roots. These curves have been arranged in the following convenient form by Schäfer (Fig. 331)] :—

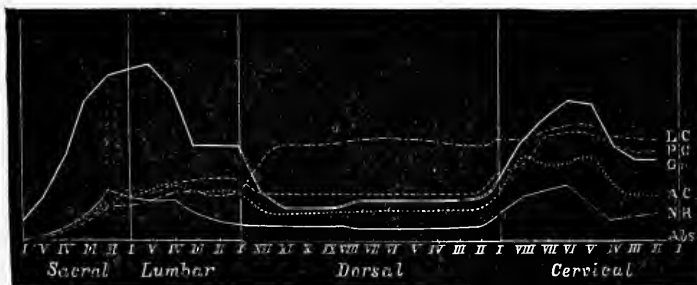

Fig. 331.

Diagram of the absolute and relative extent of the grey matter, and of the white columns in successive sectional areas of the spinal cord, as well as the sectional areas of the several entering nerve-roots; NR, nerve-roots; AC, LC, PC, anterior, lateral, and posterior columns; Gr, grey matter (Schäfer, after Ludwig and Woroschiloff).

The *anterior cornu* of the grey matter is shorter and broader, and does not reach so near to the surface as the posterior; moreover, each anterior nerve-root arises from it by several bundles—it contains several groups of large multipolar ganglionic cells; the *posterior cornu* is more pointed, longer, and narrower, and reaches nearer to the surface, the posterior root arising by a single bundle at the postero-lateral fissure; while the cornu itself contains a few fusiform nerve-cells, and is covered by the *substantia gelatinosa* of Rolando, which is merely an accumulation of neuroglia.

[The outer margin of the grey matter near its middle is not so sharply defined from the white matter as elsewhere; and, in fact, a kind of anastomosis of the grey matter projects into the lateral column, especially in the cervical region, constituting the *processus reticularis*.]

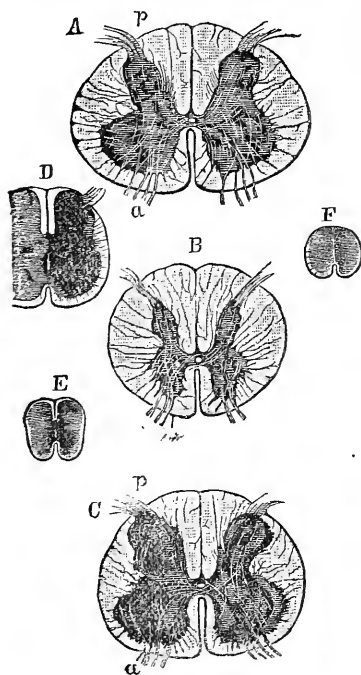

Fig. 332.

Transverse sections of the spinal cord in different regions—A, through the middle of the cervical enlargement; B, the dorsal region; C, the lumbar enlargement; D, the upper part of the conus medullaris; E, at the level of the 5th sacral vertebra; F, at the level of the coccyx; A, B, C, enlarged twice; D, E, F, thrice; a, anterior; p, posterior root.

grey matter (Fig. 330—"motor ganglionic cells"); while smaller spindle-shaped ("sensory") cells occur in much smaller numbers in the grey matter of the posterior horn.

Gerlach's Theory.—According to Gerlach, the connection of the fibres and cells is as follows:—The fibres of the anterior root proceed directly to the ganglionic cells of the anterior horn, with which they form direct communications by means of the axial cylinder processes. The grey net-work of protoplasmic processes produced by the repeated branchings of the fibres of these cells gives origin to broad fibres. A part of the latter (the *median bundle*) passes through the anterior white commissure to the other side, and then ascends in the anterior column of the opposite side. Other fibres (the *lateral bundle*) pass into the lateral column of

[In the anterior cornu, the ganglionic cells are arranged in several groups although the distribution of these groups is not the same in all parts of the cord. There is an *anterior group*, a *lateral group* near the lateral column, and a *mesial* one. Immediately behind the grey commissure, and on the inner surface of the posterior cornu is a group of large multipolar nerve-cells, known as the *posterior vesicular column* of Lockhart Clarke, or *Clarke's column*. It is almost confined to the lower part of the dorsal region. In the dorsal region there is a group of cells in the outer part of the grey matter, nearly midway between the anterior and posterior cornua, known as the *intermediolateral tract*. The arrangement of these nerve-cells in columns is very much better seen in a longitudinal section of the spinal cord.]

The **grey matter** contains an exceedingly delicate fibrous net-work of the finest nerve-fibrils (Gerlach), which is produced by the repeated division of the protoplasmic processes of the multipolar ganglionic cells. Medullated nerve-fibres traverse and divide in the grey matter and become non-medullated; some of them merely pass through the grey matter of the non-medullated fibres and terminate in Gerlach's net-work. Fibres pass from the grey matter of one side to that of the other through the commissures in front of and behind the central canal.

The **multipolar ganglionic cells** (Fig. 333) are largest, and arranged in groups in the anterior horns of the

the same side, and ascend in it as far as the decussation of the pyramids, where they cross in the medulla to the other side. The fibres of the *posterior root* enter the posterior horn, and, after dividing, terminate in the nervous protoplasmic net-work of the grey matter. By means of this net-work they are connected indirectly with the ganglionic cells of the posterior horn, which are said not to have an axial cylinder process.

The grey net-work which connects the ganglia of the anterior and posterior horns with each other, also sends fibres, which pass to the other side of the cord in front of and behind the central canal. They then take a backward course, to ascend partly in the posterior horns and partly in the lateral columns.

Neurogleia.—The *connective-tissue* of the spinal cord arises in part from the pia mater and passes only into the white matter, carrying with it blood-vessels, and forming septa, which separate the nerve-fibres into bundles. We must distinguish from the ordinary connective-tissue that special form in the grey matter to which Virchow gave the name of *neurogleia*, which is the proper sustentacular tissue. It is composed of a fine net-work, which consists of round and large-branched cells embedded in a completely homogeneous, transparent, ground substance. The central canal is surrounded with a denser layer of this tissue, known as the "*central ependyma*." The neurogleia is also abundant on the sides and apex of the posterior horns, where it is called the *gelatinous substance of Rolando*. Similar neurogleia also occurs in the brain. On the surface of the central nervous system, and in the gelatinous substance, is, in addition, a fine net-work of neurokeratin (p. 714).

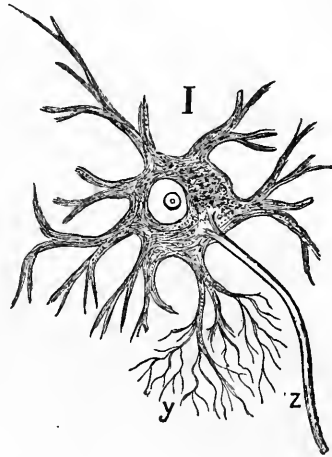

Fig. 333.

Multipolar nerve-cell, from the anterior horn of the spinal cord.

[Blood-Vessels.]—The *anterior median* artery gives off branches, which dip into the fissure of the same name, pass to its base, and, after perforating the anterior commissure, divide into two branches, one for each mass of grey matter, and each branch in turn splits into three, which supply part of the anterior, median, and posterior grey matter. The *posterior root* artery enters the grey matter along the course of the posterior nerve roots. Some branches also pass from the pia mater into the substance of the cord, and are known as the antero- and median-lateral branches, while others dip in near Goll's column, and another in the postero-external column. The large *central* artery supplies the grey matter. The general result is that the grey matter is much more vascular than the white, as is shown in Fig. 334. Adamkiewicz has given a most minute description of the blood-vessels of the spinal cord. Some small vessels come from the pia and send branches to the white matter, and unbranched arteries to the grey matter, where they form a capillary plexus. The blood-vessels are surrounded by *perivascular lymph-spaces* (His).]

[With regard to the blood-vessels supplying the cord as a whole, Moxon has pointed out that, owing to the cord not being as long as the vertebral canal, the lower nerves have to run down within the vertebral canal before they emerge from their appropriate inter-vertebral foramina. As re-enforcing arteries enter the cord along the course of these nerves, necessarily the branches entering along the course of the lumbar and lower dorsal nerves are long, and this, together with

their small size, offers considerable resistance to the blood-stream. Hence, perhaps, why the lower part of the cord is very apt to be affected by various conditions.]

Conducting Systems.—The whole of the longitudinal fibres of the spinal cord may be arranged systematically in special bundles, according to their function.

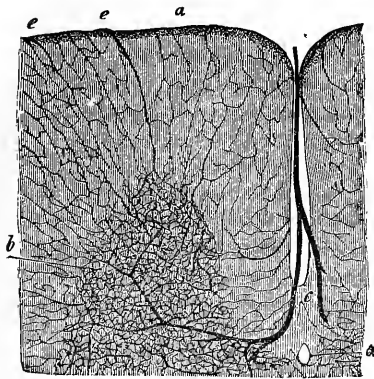

Fig. 334.

Injected blood-vessels of the spinal cord.

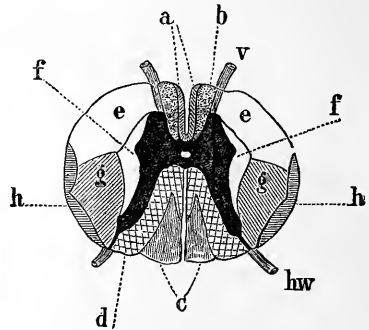

Fig. 335.

Scheme of the conducting paths in the spinal cord at the third dorsal nerve. The black part is the grey matter—*v*, anterior root; *h, w*, posterior root; *a* and *g*, pyramidal paths; *b*, anterior column ground bundle; *c*, Goll's column; *d*, Burdach's column; *e* and *f*, mixed lateral paths; *h*, direct cerebellar paths.

Türk found that, in disease of certain parts of the brain, there was always secondary degeneration of certain distinct tracts of fibres in the cord. P. Schieferdecker showed also after section of the cord, that above and below the level of the section, certain definite tracts of white matter underwent degeneration. Lastly, Flechsig showed that the fibres of the cord during development became covered with *myelin* at different periods, those fibres becoming medullated latest which had the longest course. In this way he mapped out the following systems:—

Flechsig's Systems of Fibres.—1. In the anterior column lie (*a*) the *direct* or uncrossed *pyramidal tract*; and external to it is (*b*) the *anterior ground bundle*, or *anterior radicular zone*.

2. In the posterior column he distinguishes (*c*) Goll's column, or the postero-median column; and (*d*) Burdach's funiculus cuneatus, or the posterior radicular zone, or the postero-external column.

3. In the lateral column are (*e*) the *anterior*, and (*f*) the *lateral mixed* paths, (*g*) the *crossed pyramidal* paths of the lateral columns, and (*h*) the *direct cerebellar* paths. *A* and *g* carry all the impulses from the central convolutions of the cerebrum, by means of which *voluntary* movements are executed (§ 365). The fibres in these tracts descend from the

central convolutions, traverse the crista of the pedunculus cerebri, and after partly crossing at the pyramids, pass into the spinal cord in the paths (*a* and *g*) to enter the grey matter of the spinal cord before they join the anterior roots of the spinal nerves; *h* connects the *cerebellum* directly by ascending fibres, which proceed through the restiform body from Clarke's column of nerve-cells in the grey matter. As fibres from the posterior roots also enter the latter, it follows that *h* connects the posterior nerve-roots of the trunk (but not of the extremities) with the *cerebellum*; *b*, *e*, *f* (and ? a small part of *d*) represent the channels which connect the grey matter of the spinal cord and that of the medulla oblongata, they represent the channels for reflex effects, and they also contain those fibres which are the direct continuation of the anterior spinal nerve-roots, which enter the cord at different levels and penetrate into the grey matter. In *e* and *f* there are some sensory paths. Lastly, *c* unites the posterior roots with the grey nuclei of the funiculi graciles of the medulla oblongata; *d* connects some of the posterior nerve-roots through the restiform body with the vermiform process of the *cerebellum* (Flechsig). The direction of conduction in the posterior columns, which are continuations of some of the fibres of the posterior roots, is upwards, as part of them degenerates upwards after section of the posterior root. Of the fibres of each posterior root, some pass directly into the posterior horn, another part ascends in the posterior column of the same side, and gradually as it ascends, it comes nearer the posterior median fissure. Some of these fibres enter the grey matter of the posterior horn at a higher level. The fibres of the posterior columns run upwards only as far as the decussation of the pyramids, where they seem to end, or at least form connections with the nerve-cells of the funiculi graciles [clava], and cuneati [triangular nucleus].

Further, the transverse sectional area of the direct and crossed pyramidal tracts (*a* and *g*), the lateral cerebellar tract (*h*), and Goll's column (*c*) gradually diminish from above downwards; they serve to connect intracranial central parts with the ganglionic centres distributed along the spinal cord. The anterior root bundle (*b*), the funiculus cuneatus (*d*), and the anterior mixed lateral tracts (*e*) vary in diameter at different parts of the cord, corresponding to the number of nerve-roots. It has been concluded from this, that these tracts serve to connect the grey matter at different levels in the cord with each other, and ultimately with the medulla oblongata, so that they do not pass directly to the higher parts of the brain (Fig. 331).

Nutritive Centres of the Conducting Paths.—Türck observed that the destruction of certain parts of the brain caused a *secondary degeneration* of certain parts of the cord, corresponding to the parts called *pyramidal tracts* by Flechsig (Fig. 336). P. Schieferdecker found the same effects *below* where he divided the spinal cord in a dog. Hence it is concluded, that the *nutritive* or *trophic centre* of the pyramidal tracts

lies in the cerebrum. The trophic centre for the fibres of the anterior root lies in the multipolar nerve-cells of the anterior cornu of the grey matter of the cord. After section of the spinal cord, Goll's column and the direct cerebellar tracts degenerate *upwards*. The nutritive centre of the latter is very probably in the nerve-cells of Clarke's column, and that of the former perhaps in the spinal ganglion of the posterior root.

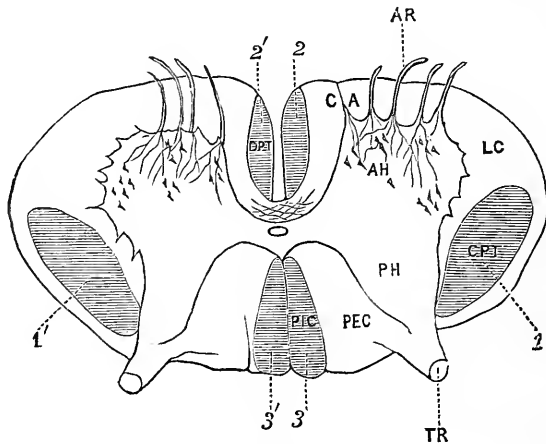

Fig. 336.

Transverse section of the spinal cord, showing the secondary degeneration tracts—AR, anterior, TR, posterior root; 1, 1' (CPT), region of the crossed pyramidal tract; 2, 2' (DPT), direct pyramidal tract; PEC, postero-external column; LC, lateral column (B. Bramwell).

Those fibres of the spinal cord which do not degenerate after section of the cord, especially numerous in the lateral and anterior columns (Schieferdecker, Singer), are commissural in function, connecting ganglionic cells with each other, and are, therefore, provided with a trophic centre at both ends.

Time of Development.—With regard to the time of development of the individual systems, Flechsig finds that the first formed paths are those between the periphery and the central grey matter, especially the *nerve-roots*, *i.e.*, they are the first to be covered with the myelin. Then fibres which connect the grey matter at different levels are formed—the fibres which connect the grey matter of the cord with the cerebellum, and also the former with the tegmentum of the cerebral peduncle. At last the fibres which connect the ganglia of the pedunculus cerebri, and perhaps also the grey matter of the cortex cerebri with the grey matter of the cord are formed. In cases of anencephalous *fœtuses*, *i.e.*, where the cerebrum is absent, neither the pyramidal tracts nor the pyramids are developed. In the *brain* before birth, medullated nerve-fibres are formed in the paracentral, central and occipital convolutions, and in the island of Reil, and last of all, in the frontal convolutions (Tuczek).

360. Spinal Reflexes.

By the term **reflex movement** is meant, a movement caused by the stimulation of an *afferent* (sensory) nerve. The stimulus, on being applied to an *afferent* nerve, sets up a state of excitement (nervous impulse) in that nerve, which state of excitement is transmitted in a *centripetal* direction along the nerve to the *centre* (spinal cord in this case), where the nerve-cells represent the *nerve-centre*; in the centre, the impulse is transferred to the motor, *efferent* or *centrifugal* channel. *Three* factors therefore are essential for a reflex motor act—a centripetal or afferent fibre, a transferring centre, a centrifugal or efferent fibre; these together constitute a *reflex arc* (Fig. 337). In a purely reflex act, all voluntary activity is excluded.

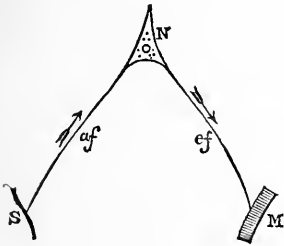

Fig. 337.

Scheme of a reflex arc—S, skin; M, muscle; N, nerve-cell, with *af*, afferent and *ef*, efferent fibres.

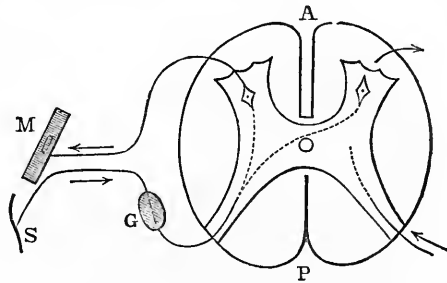

Fig. 338.

Section of a spinal segment, showing a unilateral and crossed reflex act—A, anterior, and P, posterior surface; M, muscle; S, skin; G, ganglion.

Reflex movements may be divided into the three following groups:—

I. **The simple or partial reflexes**, which are characterised by the fact, that stimulation of a sensory area discharges movement in one muscle only, or at least in one limited group of muscles. *Examples*: A blow upon the knee causes a contraction in the quadriceps extensor cruris; contact with the conjunctiva causes closure of the eyelids. In the former case, the afferent channels arise in the tendon of the quadriceps, and the efferent channels lie in the nerve which supplies the quadriceps; in the latter case, the afferent nerve is the fifth and the efferent the seventh cranial nerve. In the former case, the centre is in the lumbar region of the cord; in the latter, in the grey matter of the medulla oblongata.

II. **The Extensive, Unco-ordinate Reflexes or Reflex Spasms**.—These movements occur in the form of clonic or tetanic contractions; individual groups of muscles, or all the muscles of the body may be implicated. **Causes**: A reflex spasm depends upon a double cause—(a.) Either the grey matter or the spinal cord is in a condition of *exalted excitability*, so that the nervous impulse, after having reached the centre, is easily transferred to the neighbouring centres. This excessive excitability is produced by certain poisons, more especially by *strychnin*; brucia, caffen (Aubert), atropin, nicotin, carbolic acid, &c. The slightest touch applied to an animal poisoned with strychnin, is sufficient to throw the animal at once into spasms. Pathological

conditions may cause a similar result; thus, there is excessive excitability in hydrophobia and tetanus. On the other hand, the central organ may be in such a condition that extensive reflexes cannot take place; thus, in the condition of apnoea, the spasms that occur in poisoning with strychnin do not take place (J. Rosenthal and Leube, Uspensky), and the same result is brought about by passive artificial respiratory movements (v. Ebner—§ 361, 3). The exercise of other passive periodic movements in various parts of the body also produces a similar condition (Buchheim). If the spinal cord be cooled very considerably, reflex spasms may not occur (Kunde). (b.) Extensive reflex movements may also take place when the discharging *stimulus is very strong*. Examples of this condition occur in man, thus—intense neuralgia may be accompanied by extensive spasmodic movements.

Summation of Stimuli.—By this term is meant, that a single weak stimulus, which in itself, is incapable of discharging a reflex act, may, if repeated sufficiently often, produce this act. The single impulses are conducted to the spinal cord, in which the process of “summation” takes place. According to J. Rosenthal, 3 feeble stimuli per second are capable of producing this effect, although 16 stimuli per second are most effective. On increasing the number of stimuli per second, no further increase of the reflex act is possible. Other observers (Stirling, Ward) have found that stimuli, such as induction shocks, are active within much wider limits, *e.g.*, from 0·05 to 0·4 second interval. W. Stirling has shown that it is extremely probable, that all reflex acts are due to the repetition of impulses in the nerve-centres.

Pflüger's Law of Reflex Actions.—1. The reflex movement occurs on the *same side* on which the sensory nerve is stimulated; while only those muscles contract whose nerves arise from the same segment of the spinal cord. 2. If the reflex occurs on the *other side*, only the corresponding muscles contract. 3. If the contractions be unequal upon the two sides, then the most vigorous contractions always occur on the side which is stimulated. 4. If the reflex excitement extends to other motor nerves, those nerves are always affected which lie in the direction of the medulla oblongata. Lastly, all the muscles of the body may be thrown into contraction.

Crossed Reflexes.—They are exceptions to these rules. If the region of the eye be irritated in a frog whose cerebrum is removed, there is frequently a reflex contraction in the hind limb of the opposite side (Luchsinger, Langendorff). In beheaded tritons and tortoises, and in deeply narcotised dogs and cats, tickling one fore limb is frequently followed by a movement of the hind limb of the opposite side (Luchsinger). This phenomenon is called a “*crossed reflex*” (Fig. 338). If the spinal cord be divided along the middle line throughout its entire extent, then of course the reflexes are confined to *one side* only (Schiff).

Extensor Tetanus.—General spasms usually manifest themselves as “extensor tetanus,” because the extensors overcome the flexor muscles. Nerves which arise from the medulla oblongata may be excited through the stimulation of distant afferent nerves, without general spasms being produced.

Strychnin is the most powerful reflex-producing poison we possess, and it acts upon the grey matter of the spinal cord. [An animal poisoned with strychnin exhibits tetanic spasms on the application of the slightest stimulus. All the muscles become rigid, but the extensors overcome the flexors.] If the heart of a frog be ligatured, and the poison afterwards applied directly to the spinal cord, reflex spasms are produced, proving that strychnin acts upon the spinal cord. During the spasm, the heart is arrested in diastole, owing to the stimulation of the vagus, while the arterial blood-pressure is greatly increased, owing to stimulation of the central vaso-motor centres of the medulla oblongata and spinal cord. Mammals may die from asphyxia during the attack; still, after large doses, death may occur, owing to paralysis of the spinal cord, due to the frequently recurring spasms. Fowls are unaffected by comparatively large doses. [We can prove that strychnin does not produce spasms by acting on the brain, muscle or nerve. Destroy the brain of a frog, divide one sciatic nerve high up, and inject a small dose of strychnin into the dorsal lymph-sac; in a few minutes, all the muscles of the body, except those supplied by the divided nerve, will be in spasms, showing that although the poisoned blood has circulated in the nerves and muscles of the leg, it does not act on them. Destroy the spinal cord and the spasms cease at once.]

Other Poisons.—*Chloroform* diminishes the reflex excitability by acting upon the centre, and a similar effect is produced by picrotoxin, morphia, narcotin, thebain, aconitia, quinine, hydrocyanic acid. [W. Stirling finds that chloral, potassic bromide and chloride, ammonium chloride, but not sodium chloride, greatly diminish the reflex excitability.]

A *constant current* of electricity passed longitudinally through the cord diminishes the reflexes (Ranke), especially if the direction of the current is from above downwards (Legros and Onimus, Uspensky).

III. Extensive co-ordinated reflexes are due to stimulation of a sensory nerve, causing the discharge of complicated reflex movements in whole groups of different muscles, the movements being "*purposive*" in character, *i.e.*, as if they were intended for a particular purpose.

Methods.—The experiments are made upon *cold-blooded animals* (decapitated or pithed frogs, tortoises, or eels), or upon *mammals*. In the latter, artificial respiration is kept up, and the four arteries going to the head are ligatured, in order to eliminate the action of the brain (Sig. Mayer, Luhsinger).

The reflexes of the lower part of the spinal cord may be studied on animals (or men), in cases where the spinal cord is divided transversely in the upper dorsal region. In such cases, some time must elapse in order that the primary effect of the lesion (the so-called shock), which usually causes a diminution of the reflexes, may pass off. Very young mammals exhibit reflexes for a considerable time after they are beheaded.

Examples: 1. The **protective** movements of pithed or decapitated frogs. [If a drop of a dilute acid be applied to the skin of such a frog, immediately it strives to get rid of the offending body, and it generally succeeds in doing so.] Similarly, it kicks against any fixed body pushed against it. These movements are so purposive in their character, and the actions of groups of muscles are so adjusted to perform a particular act, that Pflüger regarded them as directed by, and due to "consciousness of the spinal cord." If a flame be applied

to the side of part of the body of an eel, the body is moved away from the flame. The tail of a decapitated triton, tortoise, newt, eel, or snake is directed towards a gentle stimulus, but if a violent stimulus is used, it is directed away from it (Luchsinger).

2. **Goltz's Croaking Experiment, or "Quarrversuch."**—A pithed (male) frog, *i.e.*, one with its cerebral lobes alone removed (or one with its eyes or ears destroyed—Langendorff), croaks every time the skin of its back or flanks is gently stroked. [Some male frogs, when held up by the finger and thumb immediately behind the fore legs, croak one or more times when gentle pressure is made on their sides.]

3. **Goltz's "Embrace Experiment."**—During the breeding season in spring, the part of the body of the male frog between the skull and the fourth vertebra, embraces every rigid object, which is brought into contact with, and gently stimulates, the skin over the sternum.

4. In mammals (dogs), the following reflex acts are performed by the posterior part of the spinal cord, after it is separated from the rest of the cord: Scratching with the hind feet a part of the skin which has been tickled (just as in intact animals); the movements necessary for emptying the bladder and for defæcation, as well as those necessary for erection; the movements necessary for parturition (Goltz, Freusberg, and Gergens). Co-ordinated movements do not as a rule occur simultaneously in portions of the spinal cord lying widely apart after removal of the medulla oblongata. According to Ludwig and Owsjannikow, the medulla oblongata perhaps contains a reflex organ of a higher order, which forms, as it were, a centre for combining, through the medium of the nerve-fibres, the various reflex provinces in the spinal cord.

5. Co-ordinated reflexes may occur in man during sleep, and during pathological comatose conditions.

Most of the movements which we perform while we are awake, and which we execute *unconsciously*—or even when our psychical activities are concentrated upon some other object—really belong to the category of co-ordinated reflexes. Many complicated motor acts must first be learned—*e.g.*, dancing, skating, riding, walking—before unconscious harmonious co-ordinated reflexes can again be discharged. The co-ordinated reflex movements of coughing, sneezing, and vomiting depend upon the spinal cord, together with the medulla oblongata.

The following facts are also important:—

1. Reflexes are more easily and more completely discharged, when the *specific end-organ* of the afferent nerve is stimulated, than when the trunk of the nerve is stimulated in its course (Marshall Hall, 1837, Volkmann, Fick and Erlenmeyer).

2. A *stronger stimulus* is required to discharge a reflex movement than for the direct stimulation of motor nerves.

3. A movement produced reflexly is of *shorter duration* than the corresponding movement executed voluntarily. Further, the occurrence of the movement after the moment of stimulation is *distinctly delayed*. In the frog, a period nearly twelve times as long elapses before the occurrence of the contraction, than is occupied in the transmission of the impulse in the sensory and motor nerves (Helmholtz, 1854). Thus, the spinal cord offers *resistance* to the transmission of impulses through it.

The term "**reflex time**" is applied to the time necessary for transferring the impulse from the afferent fibre to the nerve-cells of the cord, and from them to the efferent fibre. In the frog it is equal to 0·008-0·015 second. The time, however, is increased by almost one-third, if the impulse pass to the *other* side of the cord, or if it pass along the cord—*e.g.*, from the sensory nerves of the anterior extremity to the motor roots of the posterior limb. Heat diminishes the reflex time and increases the reflex excitability. Lowering the temperature (winter frogs), as well as the reflex-exciting poisons already mentioned, *lengthen the reflex time*, whilst the reflex excitability is simultaneously increased. Conversely, the reflex time diminishes as the strength of the stimulus increases, and it may even become of minimal duration (J. Rosenthal).

The reflex time is determined by ascertaining the moment at which the sensory nerve is stimulated, and the subsequent contraction occurs. Deduct from this the time of latent stimulation (§ 298, I.), and the time necessary for the conduction of the impulse (§ 298) in the afferent and efferent nerves (v. Helmholtz, J. Rosenthal, Exner, Wundt).

[**Influence of Poisons.**—The latent period and reflex time are influenced by a large number of conditions. In a research as yet unpublished, W. Stirling finds that the latent period may remain nearly constant in a pithed frog for nearly two days, when tested by Türk's method. Sodic chloride does not influence the time, nor does sodic bromide or iodide. Potassic chloride, however, lengthens it enormously, or even abolishes reflex action after a very short time, and so do potassic bromide, ammonium chloride and bromide, chloral and croton-chloral. The lithia salts also lengthen the reflex time, or abolish the reflex act after a time.]

361. Inhibition of the Reflexes.

Within the body there are mechanisms which can *suppress* or *inhibit* the discharge of reflexes, and they may therefore be termed **mechanisms inhibiting the reflexes**. These are:—

1. **Voluntary Inhibition.**—Reflexes may be inhibited voluntarily, both in the region of the spinal cord and brain. **Examples:** keeping the eyelids open when the eyeball is touched, arrest of movement when the skin is tickled. We must observe, however, that the suppression of the reflexes is possible only up to a certain point. If the stimulus be strong, and repeated with sufficient frequency, the reflex impulse ultimately overcomes the voluntary effort. It is impossible to suppress those reflex movements which cannot at any time be performed voluntarily. Thus, erection, ejaculation, parturition,

and the movements of the iris, are neither direct voluntary acts, nor can they, when they are excited reflexly, be suppressed by the will.

2. Setschenow's inhibitory centre is another cerebral apparatus, which in the frog is placed in the optic lobes. If the optic lobes be separated from the rest of the brain and spinal cord by a section made below it, the reflex excitability is increased. If the optic lobes be stimulated with a crystal of common salt or blood, the reflex movements are suppressed. The same results obtain when only *one* side is operated on. Similar organs are supposed to be present in the corpora quadrigemina and medulla oblongata of the higher vertebrates.

3. Strong stimulation of a sensory nerve inhibits reflex movements. The reflex does not take place if an afferent nerve be stimulated very powerfully (Goltz, Lewisson, A. Fick and Erlenmeyer).

Examples: Suppressing a sneeze by friction of the nose, [compressing the skin of the nose over the exit of the nasal nerve]; suppression of the movements produced by tickling, by biting the tongue. Very violent stimulation may even suppress the co-ordinated reflex movements usually controlled by voluntary impulses. Violent pain of the abdominal organs (intestine, uterus, kidneys, bladder, or liver) may prevent a person from walking or even from standing. To the same category belongs the fact that persons fall down when internal organs richly supplied with nerves are injured, there being neither injury of the motor nerves, nor loss of blood to account for the phenomenon.

It is important to note that in the suppression of reflexes, **antagonistic muscles** are often thrown into action, whether voluntarily or by the stimulation of sensory nerves, *i.e.*, reflexly. In some cases, in order to cause suppression of the reflex, it appears to be sufficient to direct our attention to the execution of such a complicated reflex act. Thus, some persons cannot sneeze when they think intently upon this act itself (Darwin). The voluntary impulse rapidly reaches the reflex centre, and begins to influence it, so that the normal course of the reflex stimulation, due to an impulse from the periphery, is interfered with (Schlösser).

[Nature of Inhibition.—The foregoing view assumes the existence of inhibitory centres, but it is important to point out that it has been attempted to explain this phenomenon without supposing the existence of inhibitory centres. During inhibition the function of an organ is restrained—during paralysis it is abolished, so that there is a sharp distinction between the two conditions. The analogy between inhibitory phenomena and the effects of interference of waves of light or sound has been pointed out by Bernard and Romanes, while Lauder Brunton has shown good reason for placing the question on a physical basis, and indicating that inhibition is not dependent on the existence of special inhibitory centres, but that stimulation and inhibition are different phases of excitement, the two terms being relative conditions depending

on the length of the path along which the impulse has to travel and the rate of its transmission. Brunton points out that the known facts are more consistent with an hypothesis of the interference of waves, one with another, than that there are inhibitory centres for every so-called inhibitory act in the body.]

Certain **poisons** diminish the reflex excitability, *e.g.*, chloroform, digitalis, Calabar bean, quinine, potassic bromide, &c., probably after causing a temporary increase of the excitability. [Stirling finds that ammonium and potassic chlorides, chloral, and croton-chloral also diminish it.]

If frogs be asphyxiated in air deprived of all its O, the brain and spinal cord become completely unexcitable, and can no longer discharge reflex acts. The motor nerves and the muscles, however, suffer very little, and may retain their excitability for many days (Aubert).

Türk's method of testing the reflex excitability of a frog is the following:—A frog is pithed, and after it has recovered from the shock, its foot is dipped into *dilute sulphuric acid* [2 per 1000]. The time which elapses between the leg being dipped in and the moment it is withdrawn is noted. [The time may be estimated by means of a metronome, or the movements may be inscribed upon a recording surface (Baxt). The time which elapses is known as the "period of latent stimulation."]

This time is greatly prolonged after the optic lobes have been stimulated with a crystal of common salt or blood, or after the stimulation of a sensory nerve.

Setschenow distinguished **tactile** reflexes, which are discharged by stimulation of the *nerves of touch*; and **pathic**, which are due to stimulation of *sensory* (pain-conducting) fibres. He and Paschutin suppose that the tactile reflexes are suppressed by voluntary impulses, and the pathic by the centre in the optic lobes.

Theory of Reflex Movements.—The following theory has been propounded to account for the phenomena already described:—It is assumed that the *afferent* fibre within the grey matter of the spinal cord joins one or more nerve-cells, and thus is placed in communication in all directions with the network of fibres in the grey substance. Any impulse reaching the grey matter of the cord has to overcome considerable *resistance*. The least resistance lies in the direction of those *efferent* fibres which emerge in the same plane and upon the same side as the entering fibre. Thus the feeblest stimuli gives rise to a *simple reflex*, which generally is merely a simple protective movement for the part of the skin which is stimulated.

Still greater resistance is opposed in the direction of other motor ganglia. If the reflex impulse is to pass to these ganglia, either the discharging *stimulus* must be considerably *increased*, or the *resistance* within the connections of the ganglia of the grey matter must be *diminished*. The latter condition is produced by the action of the above-named poisons, as well as during general increased nervous excitability (hysteria, nervousness). Thus, extensive reflex spasms may be produced either by increasing the stimulus, or by diminishing the resistance to con-

duction in the spinal cord. Those conditions which render the occurrence of reflexes more difficult, or abolish them altogether, must be regarded as increasing the resistance in the reflex arc in the cord. The action of the reflex inhibitory mechanism may be viewed in a similar manner.

The fibres of the reflex arc must have a connection with the reflex inhibitory paths; we must assume that equally by the reflex inhibitory stimulation resistance is introduced into the reflex arc. The explanation of *extensive co-ordinated movements* is accompanied with difficulties. It is assumed, that by use and also by heredity, those ganglionic cells which are the first to receive the impulse, are placed in the path of least resistance in connection with those cells which transfer the impulse to the groups of muscles, whose contraction, resulting in a co-ordinated purposive movement, prevents the body or the limb from being affected by any injurious influences.

Pathological.—Anomalies of reflex activity afford an important field to the physician in the investigation of nervous diseases. **Enfeeblement**, or even complete **abolition** of the reflexes may occur:—(1) Owing to diminished sensibility or complete insensibility of the afferent fibres; (2) in analogous affections of the central organ; (3) or, lastly, of the efferent fibres. Where there is general depression of the nervous activity (as after shocks, compression or inflammation of the central nervous organs; in asphyxia, in deep coma, and in consequence of the action of many poisons), the reflexes may be greatly diminished or even abolished.

[The physician, by studying the condition of the reflexes, can form an idea as to the condition of practically every inch of the spinal cord. There are three groups of reflexes, (*a*) the superficial, (*b*) the deep or tendon, (*c*) the organic reflexes.]

[The superficial or skin reflexes are excited by stimulating the skin, *e.g.*, by tickling, pricking, scratching, &c. We can obtain a series of reflexes from below as far up as the lower part of the cervical region. The *plantar reflex* is obtained by tickling the soles of the feet, when the leg on that side, or, it may be, both legs are drawn up. It is always present in health, and its centre is in the lumbar enlargement of the cord. The *cremasteric reflex* is well marked in boys, and is easily produced by exciting the skin on the inner side of the thigh, when the testicle on that side is elevated. The *gluteal reflex* consists in a contraction of the gluteal muscles, when the skin over the buttock is stimulated. The *abdominal reflex* consists in a similar contraction of the abdominal muscles, when the skin over the abdomen in the mammary line is stimulated. The *epigastric reflex* is obtained by stimulating the skin in front between the fourth and sixth ribs. The *interscapular reflex* results in a contraction of the muscles attached to the scapula, when the skin between the scapulæ is stimulated. Its centre corresponds to the lower cervical and upper dorsal region.]

[The following table, after Gowers, shows the relation of each reflex to the spinal segment or segments on which it depends:—

Cervical, 6	} Inter- Scapular.	Lumbar, 1	} Cremasteric. } Knee Reflex.
" 7		" 2	
" 8		" 3	
Dorsal, 1	} Epigastric.	" 4	} Gluteal.
" 5		" 5	
" 6		Sacral, 1	
" 7	} Abdominal.	" 2	} Ankle Clonus. } Plantar. } Vesical. } Rectal. } Sexual.]
" 8		" 3	
" 9		" 4	
" 10		" 5	
" 11			
" 12			

Tendon Reflexes.—Under pathological conditions, special attention is directed to the so-called tendon reflexes, which depend upon the fact, that a blow upon a tendon (*e.g.*, the quadriceps femoris, tendo achilles, &c.) discharges a reflex contraction of the corresponding muscle (Westphal, Erb, 1875, Eulenburg and others); that the patellar tendon reflex (also called "*knee phenomenon*") or simply "*knee reflex*," is invariably absent in cases of ataxic tabes dorsalis, while in spastic spinal paralysis (Erb) it is abnormally strong and extensive. Section of the motor nerves abolishes the patellar phenomenon in rabbits (Schultze), and so does section of the cord opposite the 5th–6th lumbar vertebræ (Tschirjew, Senator). Landois finds that in his own person the contraction occurs 0·048 second after the blow upon the ligamentum patellæ. According to Waller, the patellar reflex and the tendo achilles reflex occurs 0·03–0·04 second, and, according to Eulenburg, 0·032 second after the blow. According to Westphal, these phenomena are not simple reflex processes, but complex conditions intimately dependent upon the muscle tonus, so that when the tonus of the quadriceps femoris is diminished, the phenomenon is abolished. In order that the phenomenon may take place, it is necessary that the outer part of the posterior column of the spinal cord remain intact (Westphal). Another important diagnostic reflex is the "**abdominal reflex**" (O. Rosenbach), which consists in this, that when the skin of the abdomen is stroked, *e.g.*, with the handle of a percussion hammer, the abdominal muscles contract. When this reflex is absent on both sides in a cerebral affection, it indicates a diffuse disease of the brain; its absence on one side indicates a local affection of the opposite half of the brain. The **cremasteric, conjunctival, mammillary, pupillary, and nasal** reflexes may also be specially investigated. In hemiplegia complicated with cerebral lesions, the reflexes on the paralysed side are diminished, whilst not unfrequently the patellar reflex may be increased. In *extensive* cerebral affections accompanied by coma, the reflexes are absent on both sides (O. Rosenbach), including of course those of the anus and bladder.

[Method.—The patellar reflex is easily elicited by striking the patellar tendon with the edge of the hand or a percussion hammer when the leg is semi-flexed, as when the legs are hanging over the edge of a table or when one leg is crossed over the other. It is almost invariably present in health, but it becomes greatly exaggerated in descending degeneration of the lateral columns and lateral sclerosis.]

[Ankle clonus is another tendon reflex, and it is never present in health. If the leg be nearly extended, and pressure made upon the sole of the foot so as suddenly to flex the foot at the ankle, a series of (5–7 per second) rhythmical contractions of the muscles of the calf takes place. Gowers describes a modification elicited by tapping the muscles of the front of the leg, the “*front-tap contraction*.” Ankle clonus is excessive in sclerosis of the lateral columns and spastic paralysis.]

[The organic reflexes include a consideration of the acts of micturition, erection, ejaculation, defæcation, and those connected with the motor and secretory digestive processes, respiration, and circulation.]

When we are about to sleep (§ 374), there is first of all a temporary increase of the reflexes; in the first sleep the reflexes are diminished, and the pupils are contracted. In deep sleep, the abdominal, cremasteric, and patellar reflexes are absent; while tickling the soles of the feet and the nose, only acts when the stimulus is of a certain intensity. In narcosis (*e.g.*, chloroform or morphia), the abdominal, then the conjunctival and patellar reflexes disappear; lastly, the pupils contract (O. Rosenbach).

Abnormal increase of the reflex activity usually indicates an increase of the excitability of the reflex centre, although an abnormal sensibility of the afferent nerve may be the cause. As the harmonious equilibrium of the voluntary movements is largely dependent upon and regulated by the reflexes, it is evident that, in affections of the spinal cord, there are frequent disturbances of the voluntary movements, *e.g.*, the characteristic disturbance of motion in attempting to walk, and in grasping movements exhibited by persons suffering from ataxic tabes dorsalis [or, as it is more generally called, *locomotor ataxia*.]

362. Centres in the Spinal Cord.

At various parts of the spinal cord are placed centres, which are capable of being excited reflexly, and which can bring about the discharge of certain complicated, yet well-co-ordinated motor acts. These centres still retain their activity after the spinal cord is separated from the medulla oblongata; further, those centres lying in the lower part of the spinal cord still retain their activity after being separated from the higher centres, but in the normal intact body, these centres are subjected to the control of higher reflex centres in the *medulla oblongata*. Hence, we may speak of them as subordinate spinal centres. The *cerebrum* also, partly by the production of perceptions, and partly as the organ of volition, can excite or suppress the action of certain of these subordinate spinal centres.

1. The centre for the dilatation of the pupil lies in the lower cervical part of the cord, and extends downwards to the region of the 1st to the 3rd dorsal vertebra, constituting Budge's cilio-spinal centre. It is excited by diminution of light; *both* pupils always react simultaneously, when *one* retina is shaded. Unilateral extirpation of this part of the spinal cord causes contraction of the pupil on the same side. The motor fibres pass out by the anterior roots of the two lower cervical and two upper dorsal nerves, into the cervical sympathetic (p. 831, § 392). Even the idea of darkness may sometimes, though rarely, cause dilatation of the pupil (Budge).

In goats and cats this centre, even after being separated from the medulla oblongata, can be excited directly by dyspnoëic blood, and also reflexly by the stimulation of sensory nerves, *e.g.*, the median, especially when the reflex excitability of the cord is increased by the action of strychnin or atropin (Luchsinger). For the dilator centre in the medulla oblongata see § 367, 8.

2. The centre for defæcation, or Budge's ano-spinal centre. The afferent nerves lie in the hæmorrhoidal and inferior mesenteric plexuses, the centre at the 5th (dog) or 6th-7th (rabbit) lumbar vertebra; the efferent fibres arise from the pudendal plexus and pass to the sphincter muscles. For the relation of this centre to the cerebrum see § 160. After section of the spinal cord [in dogs], Goltz observed that the sphincter contracted rhythmically upon the finger introduced into the anus; the co-ordinated activity of the centre therefore would seem to be possible only when the centre remains in connection with the brain.

3. The centre for micturition, or Budge's vesico-spinal centre. The centre for the *sphincter* muscle lies at the 5th (dog) or the 7th (rabbit) lumbar vertebra, and that for the muscles of the *bladder* somewhat higher. The centre acts only in a properly co-ordinated way in connection with the brain (§ 280).

4. The centre for erection (§ 436) also lies in the lumbar region. The afferent nerves are the sensory nerves of the penis; the efferent nerves for the deep artery of the penis are the vaso-dilator nerves, arising from the 1st-3rd sacral nerves, or Eckhard's *nervi erigentes*—while the motor nerves for the ischiocavernosus and deep transverse perineal muscles arise from the 3rd-4th sacral nerves. The latter may also be excited voluntarily, the former also partly by the brain, by directing the attention to the sexual activity. Eckhard observed erection to take place after stimulation of the higher regions of the spinal cord, as well as of the pons and crura cerebri.

5. The centre for ejaculation. The afferent nerve is the dorsal of the penis, the centre (Budge's genito-spinal centre) lies at the 4th lumbar vertebra (rabbit); the motor fibres of the vas deferens arise from the 4th and 5th lumbar nerves, which pass into the sympathetic, and

from thence to the vas deferens. The motor fibres for the bulbo-cavernosus muscle, which ejects the semen from the bulb of the urethra, lie in the 3rd and 4th sacral nerves (perineal).

6. The centre for the act of parturition (§ 453) lies at the 1st and 2nd lumbar vertebræ (Körner); the afferent fibres come from the uterine plexus, to which also the motor fibres proceed. Goltz and Freusberg observed that a bitch became pregnant after its spinal cord was divided at the 1st lumbar vertebra.

7. **Vaso-motor Centres.** Both vaso-motor and vaso-dilator centres are distributed throughout the whole spinal axis. To them belongs the centre for the *spleen*, which in the dog is opposite the 1st–4th cervical vertebræ (Bulgak). They can be excited reflexly, but they are also controlled by the dominating centre in the medulla oblongata (§ 371). Psychological disturbance (cerebrum) influences them (§ 377).

8. The centre for the secretion of sweat is perhaps distributed similarly to the vaso-motor centres (§ 288).

The reflex movements discharged from these centres are orderly co-ordinated reflexes, and may thus be compared to the orderly reflexes of the trunk and extremities.

Muscle Tonus.—Formerly *automatic* functions were ascribed to the spinal cord, one of these being that it caused a moderate active tension of the muscles—a condition that was termed *muscle tone*, or tonus. The existence of tonus in a striped muscle was thought to be proved by the fact that, when such a muscle was divided, its ends retracted. This is due merely to the fact that all the muscles are stretched slightly beyond their normal length (p. 663).

Even paralysed muscles, which have lost their muscular tone, show the same phenomenon. Formerly, the stronger contraction of certain muscles, after paralysis of their antagonists, and the retraction of the facial muscles to the sound side, after paralysis of the facial nerve, were also regarded as due to tonus. This result is simply due to the fact that, after the activity of the intact muscles, the other ones have not sufficient power to restore the parts to their normal median position. The following experiment of Auerbach and Heidenhain is against the assumption of a tonic contraction:—If the muscles of the leg of a decapitated frog be stretched, it is found that they do not elongate after section of the sciatic nerve, or after it is paralysed by touching it with ammonia or carbolic acid.

Reflex Tonus.—If, however, a decapitated frog be suspended in an *abnormal* position, we observe, after section of the sciatic nerve, or the posterior nerve-roots on one side, that the leg on that side hangs limp, while the leg of the sound side is slightly retracted. The sensory nerves of the latter are slightly and continually stimulated by the weight of the limb, so that a slight reflex retraction of the leg takes place, which disappears as soon as the sensory nerves of the leg are divided. If we choose to call this slight retraction, tonus, then it is a reflex tonus (Brondegeest). (See the experiments of Harless, C. Ludwig, and Cyon—p. 828).

363. Excitability of the Spinal Cord.

Even at the present time, observers are by no means agreed whether the spinal cord, like peripheral nerves, is excitable, or whether it is

distinguished by the remarkable peculiarity that most of its conducting paths and ganglia do not react to *direct electrical* and *mechanical* stimuli.

If stimuli be cautiously applied either to the white or grey matter, there is neither movement nor sensation (Van Deen, 1841, Brown-Séguard, Schiff, Huizinga, Sigm. Mayer).

In doing this experiment, we must be careful not to stimulate the roots of the spinal nerves, as these respond at once to stimuli, and thus may give rise to movements or sensations. As the spinal cord conducts to the brain impulses communicated to it from the stimulated posterior roots, but does not itself respond to stimuli which produce sensations, Schiff has applied to it the term "*æsthesodic*." Further, as the cord can conduct both voluntary and reflex motor impulses, without however itself being affected by motor impulses applied to it directly, he calls it "*kinesodic*." Schiff's views are as follows:—

1. In the posterior columns, the sensory root fibres of the posterior root which traverse these columns give rise to painful impressions, but the proper paths of the posterior columns themselves do not do so. The proof that stimulation of the posterior column produces sensory impressions, he finds in the fact that dilatation of the pupil occurred with every stimulation (§ 392). Removal of the posterior column produces anæsthesia (loss of tactile sensation). Algæsia [or sensations of pain] remains intact, although at first there may even be hyperalgæsia.

2. The anterior columns are non-excitable, both for striped and non-striped muscle, as long as the stimuli are applied only to the proper paths of this column. But movements may follow, either when the anterior nerve-roots are stimulated, or when, by the escape of the current, the posterior columns are affected, whereby reflex movements are produced.

According to Schiff, therefore, all the phenomena of irritation, which occur when an uninjured cord is stimulated (spasms, contracture), are caused either by simultaneous stimulation of the anterior roots, or are reflexes from the posterior columns alone, or simultaneously from the posterior columns and the posterior roots. Diseases affecting only the anterior and lateral columns alone never produce symptoms of irritation, but always of paralysis.

In complete anæsthesia and apnoea, every form of stimulus is quite inactive. According to Schiff's view, all centres, both spinal and cerebral, are inexcitable by artificial means.

Direct Excitability.—Many observers, however, oppose these views, and contend that the spinal cord is excitable to direct stimulation. Fick observed movements to take place when he stimulated the white columns of the cord of a frog, isolated for a long distance so as to avoid the escape of the stimulating currents. Biedermann comes to the following conclusions:—The transverse section of a motor nerve is most excitable. Weak stimuli (descending opening shocks) excite the cut surface of the transversely divided spinal cord, but do not act when applied further down. Luchsinger asserts that, after dipping the anterior part of a beheaded snake in warm water, the reflex movements of the upper part of the cord are abolished, while the direct excitability remains.

3. **Excitability of the Vaso-motors.**—The *vaso-constrictor* nerves, which proceed from the vaso-motor centre and run downwards in the cord, are excitable by all stimuli along their whole course; direct stimulation of any transverse section of the cord constricts all the blood-vessels below the point of section (C. Ludwig and Thiry). In the same way, the fibres which ascend in the cord, and increase the action of the vaso-motor centre—*pressor fibres*, are also excitable (C. Ludwig and Dittmar—§ 364, 10). Stimulation of these fibres, although it affects the vaso-motor centre reflexly, does not cause sensation. Schiff maintains, however, that these are not the *direct* results of stimulation.

4. **Chemical Stimuli.**—Such as the application of common salt, or wetting the cut surface with blood, appear to excite the spinal cord.

5. The **motor centres** are directly excited by *blood heated* above 40°, or by asphyxiated blood, or by sudden and complete anæmia of the cord produced by ligature of the aorta (Sigm. Mayer); and also by certain poisons—picrotoxin, nicotin, and compounds of barium (Luchsinger).

Action of Blood and Poisons.—In experiments of this kind, the spinal cord ought to be divided at the 1st lumbar vertebra, at least 20 hours before the experiment is begun. It is well to divide the posterior roots beforehand, to avoid reflex movements. If in a cat thus operated on, *dyspnœa* be produced, or its *blood overheated*, then *spasms, contraction of the vessels, and secretion of sweat* occur in the hind limbs, together with evacuation of the contents of the *bladder and rectum*, while there are movements of the *uterus* and the *vas deferens*. Some poisons act in a similar manner. In animals with the medulla oblongata divided, rhythmical respiratory movements may be produced, if the spinal cord has been previously rendered very sensitive by strychnin or overheated blood (P. v. Rokitsansky, v. Schroff—§ 368).

Hyperæsthesia.—After unilateral section of the cord, or even only of the posterior or lateral columns, there is *hyperæsthesia* on the same side below the point of section (Fodéra, 1823, and others), so that rabbits shriek on the slightest touch. The phenomenon may last for three weeks, and then give place to normal or sub-normal excitability. On the sound side the sensibility remains permanently diminished. A similar result has been observed in cases of injury in man. An analogous phenomenon, or a tendency to contraction in the muscles below the section (*Hyperkinesia*), has been observed by Brown-Séquard after section of the anterior columns.

364. The Conducting Paths in the Spinal Cord.

[**Posterior Root.**—The fibres of the posterior root enter the cord in three bundles—(a) the inner one, or *internal radicular fasciculus* sweeps through the postero-external column to enter the grey matter. It is

supposed to convey the impressions from tendons, and those for touch and locality. Hence, when this column is diseased, as in locomotor ataxia, the deep reflexes, especially the patellar tendon reflex, are enfeebled, or it may be abolished, while the implication of the fibres of the internal fasciculus gives rise to severe pain. (b) The *outer radicular* fibres enter the grey matter of the posterior horn, and are supposed to convey the impressions for cutaneous reflexes and temperature. (c) The *central* fibres pass directly into the grey matter, and are supposed to conduct painful impressions into the grey matter.]

1. **Localised tactile sensations** (temperature, pressure, and the muscular sense impressions) are conducted upwards through the posterior roots to the ganglia of the posterior cornu, and lastly, into the posterior column of the same side.

In *man*, the conducting path from the legs run in Goll's column, while those for the arms run in the ground bundle—Fig. 335 (Flechsig).

In *rabbits*, the path of localised tactile impressions lies in the lower dorsal region in the lateral columns (Ludwig and Woroschiloff, Ott and Meade Smith).

Anæsthesia.—Section of individual parts of the lateral columns abolishes the sensibility for the parts of the skin connected with the part destroyed, while total section produces the same result for the whole of the opposite side of the body below the section. The condition, where tactile and muscular sensibility is lost, is known as *anæsthesia*.

2. **Localised voluntary movements** in man are conducted on the same side through the anterior and lateral columns (§§ 358 and 365), in the parts known as the *pyramidal tracts*. The impulses then pass into the cells of the anterior cornu, and from thence to the corresponding anterior nerve-roots to the muscles.

The exact section experiments of Ludwig and Woroschiloff showed that, in the lower dorsal region of the *rabbit*, these paths were confined to the lateral columns.

Every motor nerve-fibre is connected with a nerve-cell in the anterior horn of the frog's spinal cord (Gaule and Birge).

Partial section of one lateral column abolishes *voluntary* movement in the corresponding individual muscles below the point of section. It is obvious from the conduction in 1 and 2, that the lateral columns must increase in thickness and number of fibres from below upwards (Stilling, Woroschiloff) [see Fig. 331].

Tactile (extensive and co-ordinated) reflexes.—The fibres enter by the posterior root, and proceed to the posterior cornu. The groups of ganglionic cells, which control the co-ordinated reflexes, are connected together by fibres which run in the anterior tracts, the anterior ground bundle and (?) the direct cerebellar tracts (p. 840). The fibres for the muscles which are contracted pass from the motor ganglia outwards through the anterior roots.

In **ataxic tabes dorsalis** or **locomotor ataxia**, there is a degeneration of the posterior columns, characterised by a peculiar motor disturbance. The voluntary movements can be executed with full and normal vigour, but the finer harmonious adjustments are wanting or impaired, both in intensity and extent. These depend in part upon the normal existence of tactile and muscular impressions, whose channels lie in the posterior columns. After degeneration of the latter, there is not only anaesthesia, but also a disturbance in the discharge of tactile reflexes, for which the centripetal arc is interrupted. But a simultaneous lesion of the sensory nerves alone may in a similar manner materially influence the harmony of the movements, owing to the analgesia and the disappearance of the pathic reflexes (§ 355). As the fibres of the posterior root traverse the white posterior columns, we can account for the disturbances of sensation which characterise the degenerations of these parts (Charcot and Pierret). But even the posterior roots themselves may undergo degeneration, and this may also give rise to disturbances of sensation (p. 828). The sensory disturbances usually consist in an abnormal increase of the tactile or painful sensations, with lightning pains shooting down the limbs, and this condition may lead on to one, where the tactile and painful sensations are abolished. At the same time, owing to stimulation of the posterior columns, the tactile sensibility is altered, giving rise to the sensation of formication, or a feeling of constriction [*"girdle sensation"*]. The conduction of sensory impressions is often *slowed* (p. 770). The sensibility of the muscles, joints, and internal parts is altered.

The **maintenance of the equilibrium** is largely guided by the impulses which travel inwards to the co-ordinating centres through the sensory nerves, special and general, deep and superficial. In many cases of locomotor ataxia, if the patient place his feet close together and close his eyes, he sways from side to side and may fall over, because by cutting off the guiding sensations obtained through the optic nerve, the other enfeebled impulses obtained from the skin and the deeper structures are too feeble to excite proper co-ordination.

4. The **inhibition of tactile reflexes** occurs through the anterior columns; the impulses pass from the anterior column at the corresponding level into the grey matter, where they form connections with the reflex conducting apparatus.

5. The conduction of **painful impressions** occurs through the posterior roots, and thence through the whole of the grey matter. There is a partial decussation of these impulses in the cord, the conducting fibres passing from one side to the other. The further course of these fibres to the brain is given in § 365.

The experiments of Weiss on dogs, by dividing the lateral column at the limit of the dorsal and lumbar regions, showed that each lateral column contains sensory fibres for *both* sides. The chief mass of the motor fibres remains on the *same* side. Section of *both* lateral columns abolishes completely sensibility and motility on both sides. The anterior columns and the grey matter are not sufficient to maintain these. If all the grey matter be divided, except a small connecting portion, this is sufficient to conduct painful impressions. In this case, however, the conduction is *slower* (Schiff). Only when the grey matter is completely divided is the conduction of painful impressions from below completely interrupted. This gives rise to the condition of **analgesia**, in which, when the posterior columns are still intact, tactile impressions are still conducted. This condition is sometimes observed in man during incomplete narcosis from chloroform and morphia (Thiersch). These poisons act sooner on the nerves which administer to painful

sensations than on those for tactile impressions, so that the person operated on is conscious of the contact of a knife, but not of the painful sensations caused by the knife dividing the parts.

Irradiation of Pain.—As painful impressions are conducted by the whole of the grey matter, and as the impressions are more powerful the stronger the painful impression, we may thus explain the so-called irradiation of painful impressions. During violent pain, the pain seems to extend to wide areas; thus, in violent toothache, proceeding from a particular tooth, the pain may be felt in the whole jaw, or it may be over one side of the head.

6. The conduction of **spasmodic, involuntary, unco-ordinated** movements takes place through the grey matter, and from the latter through the anterior roots.

It occurs in epilepsy, in poisoning with strychnin, in uræmic poisoning, and tetanus (§ 360, II.). The anæmic and dyspnœic spasms are excited in and conducted from the medulla oblongata, and are communicated through the whole of the grey matter.

7. The conduction of **extensive reflex spasms** takes place from the posterior roots to the ganglia of the posterior, and then to the anterior cornu, and, lastly, into the anterior roots, under the conditions already referred to in § 360, II.

8. The **inhibition of pathic reflexes** occurs through the anterior columns downwards, and then into the grey matter to the connecting channels of the reflex organ, into which it introduces resistance.

9. The **vaso-motors** run in the lateral columns (Dittmar), and, after they have passed into the ganglia of the grey matter at the corresponding level, they leave the spinal cord by the anterior roots. They reach the muscles of the blood-vessels either through the paths of the spinal nerves, or they pass through the rami communicantes into the sympathetic, and from thence into the visceral plexuses.

Section of the spinal cord paralyses all the vaso-motor nerves below the point of section; while *stimulation* of the peripheral end of the spinal cord causes contraction of all these vessels.

10. **Pressor fibres** enter through the posterior roots, run upwards in the lateral columns, and undergo an incomplete decussation (C. Ludwig and Miescher).

They ultimately terminate in the *dominating vaso-motor centre* in the medulla oblongata, which they excite reflexly. Similarly, *depressor* fibres must pass upwards in the spinal cord, but we know nothing as to their course.

11. From the **respiratory centre** in the medulla oblongata, *respiratory nerves* run downwards in the lateral columns on the *same* side, and without forming any connections with the ganglia of the anterior cornu

(?) pass through the anterior roots into the motor nerves of the respiratory muscles (Schiff).

Unilateral, or total destruction of the spinal cord, the higher up it is done, accordingly paralyses more and more of the respiratory nerves, on the same or on both sides. Section of the cord above the origin of the phrenic nerves causes death, owing to the paralysis of these nerves of the diaphragm (p. 236).

In **pathological cases**, in degeneration of, or direct injury to, the spinal cord or its individual parts, we must be careful to observe whether there may not be present simultaneously paralytic and irritative phenomena, whereby the symptoms are obscured.

[Complete transverse section of the cord results in complete paralysis of motion and sensation in all the parts supplied by nerves below the seat of the injury, although the muscles below the injury retain their normal trophic and electrical conditions. There is a narrow hyperæsthetic area at the upper limit of the paralysed area, and when this occurs in the dorsal region, it gives rise to the feeling of a belt tightly drawn round the waist, or the "girdle sensation." There is also vaso-motor paralysis below the lesion, but the blood-vessels soon regain their tone owing to the subsidiary vaso-motor centres in the cord. The *remote effects* come on much later, and are secondary descending degeneration in the crossed and direct pyramidal tracts and ascending degeneration in the postero-internal columns (Fig. 336). According to the seat of the lesion, the functions of the bladder and rectum may be interfered with. Injury to the upper cervical region sometimes causes hyperpyrexia.]

[Unilateral section results in paralysis of voluntary motion in the muscles supplied by nerves given off below the seat of the injury, although the muscles do not atrophy, but when secondary descending degeneration occurs, they become rigid, and exhibit the ordinary signs of contracture. There is vaso-motor paralysis on the same side, below the injury, while the ordinary and muscular sensibility are diminished on both sides. There is bilateral anæsthesia, although it is most marked on the opposite side. The sensory nerves decussate shortly after they enter the cord, hence the anæsthesia on the opposite side, but they do not cross at once, but run obliquely upwards before they enter the grey matter of the opposite side, so that a unilateral section will involve some fibres coming from the same side, and hence the slightly diminished sensibility on the same side. There is a narrow hyperæsthetic area on the same side as the lesion, at the upper limit of paralysed cutaneous area, due perhaps to stimulation of the cut ends of the sensory fibres on that side. The *remote effects* are due to the usual descending and ascending degeneration which set in.]

The Brain.

365. General Schema of the Brain.

In an organ so complicated in its structure as the brain, it is necessary to have a general view of the chief arrangements of its individual parts. Meynert gave a plan of the general arrangement of this organ, and, although this plan may not be quite correct, still it is useful in the study of brain function.

The *mean weight* of the brain in man is about 1,358 grammes ; of woman, 1,220 grammes (Bischoff).

[**Structure of the Cerebrum.**—In the cerebrum the *grey matter* (*cortex*) is outside, and it invests the white matter within. On making a vertical section of a cerebral convolution, it is seen to consist of the following layers (Fig. 339, after Meynert). It is covered on its surface by the pia mater—(1) the most superficial layer consists of much neuroglia, a net-work of branched nerve-fibrils, and a few scattered small multipolar nerve-cells ; (2) a layer of close-set, small pyramidal nerve-cells ; (3) the thickest layer or formation of the cornu ammonis, consisting of several layers of large pyramidal ganglionic cells, which are larger in the deeper layers. Each cell is more or less pyramidal in shape, giving off several processes, (*a*) an *apical* process, which is often very long, and runs towards the surface of the cerebrum, where it is said to terminate in an ovoid corpuscle, closely resembling those in which the ultimate branches of Purkinje's cells of the cerebellum end. (*b*) The unbranched *median basilar* process, which is an axial cylinder of a nerve-fibre of the white matter. It ultimately becomes invested by myelin. (*c*) The *lateral* processes are given off chiefly near the base of the cell, and they soon branch to form part of the ground plexus of fibrils which everywhere pervades the grey matter. (4.) A narrow layer of numerous small branched, irregular, ganglionic cells—the "*granular formation*" of Meynert. (5.) A layer of spindle-shaped branched cells—the *claustral formation* of Meynert, lying for the most part parallel to the surface of the convolution. Then follows the *white matter* (*m*), consisting of medullated nerve-fibres, which run in groups into the grey matter, where they lose their myelin. The fibres are somewhat smaller than in the other parts of the nervous system (diameter $\frac{1}{100000}$ inch). Each cell is surrounded by a lymph-space, as in those of the cord.]

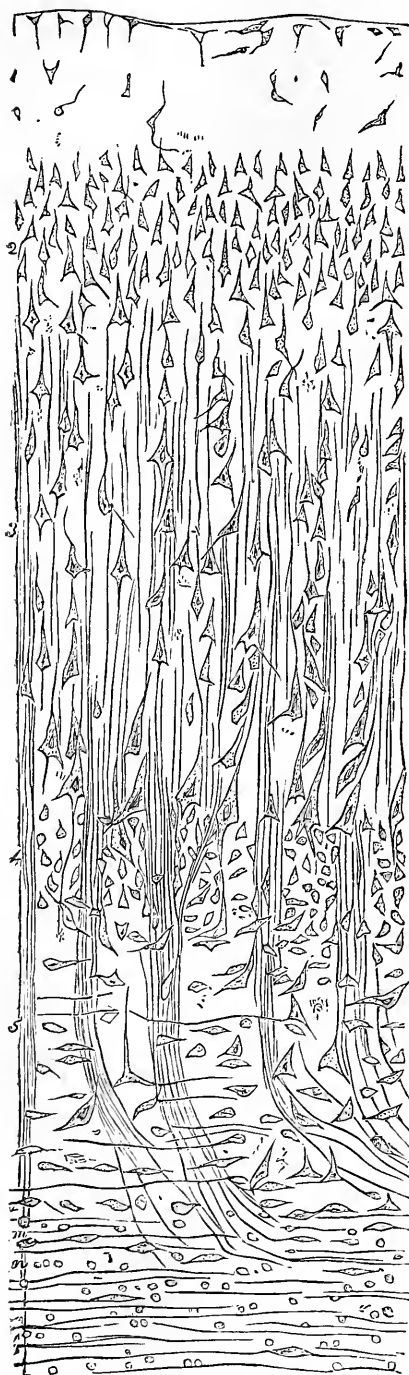

[Although the above description indicates the typical arrangement, still the grey matter differs in different parts of the brain. In the grey matter of the cornu ammonis the large pyramidal cells (3) make up the chief mass, in the claustrum (4) is most abundant, while in part of the occipital lobes the granular formation is very thick.]

[**Blood - Vessels.**—The grey matter is much more vascular than the white, and when injected a section of a convolution presents the appearance shown in Fig. 340, after Duret. The *nutritive* arteries consist of—(a) the long *medullary arteries* (Fig. 340, 1), which pass from the pia mater through the grey matter into the central white matter or centrum ovale. They are *terminal* arteries, and do not communicate with each other in their course; they thus supply independent vascular areas, nor do they anastomose with any of the arteries derived from the ganglionic system of blood-vessels; 12–15 of them are seen a section of a convolution. (b.) The short *cortical nutritive* arteries (Fig. 340, 2) are smaller and shorter than the foregoing. Although some of them enter the white matter, they chiefly supply the cortex, where they form an open meshed plexus

Fig. 339.

Vertical section of the third cerebral convolution of man—1, Layer of scattered small cortical corpuscles; 2, layer of close-set small pyramidal cortical corpuscles; 3, layer of large pyramidal corpuscles (formation of the cornu ammonis); 4, layer of small, close-set irregularly shaped cortical corpuscles (granule-like formation); 5, layer of fusiform cortical corpuscles (claustral formation); *m*, the medullary lamina.

in the first layer (*a*), while in the next layer (*b*) the plexus of capillaries is dense, the plexus again being wider in the inner layers (*c*).

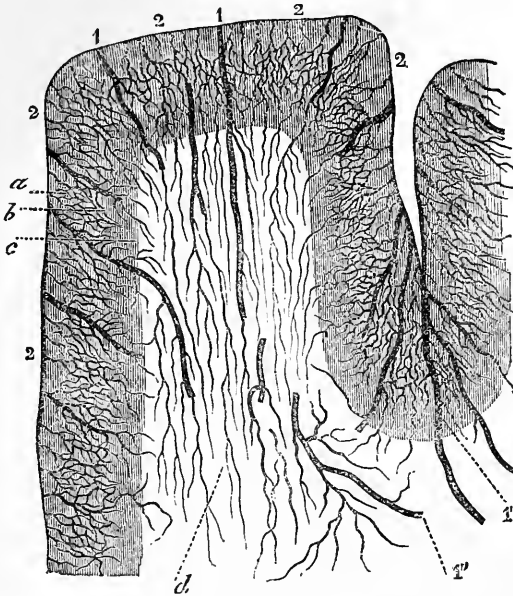

Fig. 340.

1, 1, medullary arteries; 1', 1', group of medullary arteries between the convolutions; 2, 2, 2, arteries of the cortex cerebri; *a*, large meshed plexus in first layer; *b*, closer plexus in middle layer; *c*, open plexus in the grey matter next the white substance, with its vessels (*d*)—(after Duret.)

[**Central or Ganglionic Arteries.**—From the trunks constituting the circle of Willis (Fig. in § 381), branches are given off, which pass upwards and enter the brain to supply the basal ganglia with blood. They are arranged in several groups, but they are all *terminal*, each one supplying its own area, nor do they anastomose with the arteries of the cortex.]

Meynert's Projection Systems.—The cortex of the cerebrum consists of convolutions and sulci, the "*peripheral grey matter*" (Fig. 341, C), which is recognised as a nervous structure from the presence of numerous ganglionic cells in it (§ 35S, 1). From it proceed all the motor fibres which are excited by the will, and to it proceed all the fibres coming from the organs of special sense and sensory organs, which give rise to the psychical perception of external impressions.

[In Fig. 341 the decussation of the sensory fibres is represented as occurring near the medulla oblongata. It is more probable that a large number of the sensory fibres decussate shortly after they enter the cord, as is represented in Fig. 343. Some observers assert that some of the sensory fibres decussate in the medulla oblongata.]

First Projection System.—The channels lead to and from the cortex cerebri, some of them traversing the *basal ganglia*, or ganglia of the cerebrum—the corpus striatum (*C, s*), lenticular nucleus (*N, l*), optic thalamus (*T, o*), and corpora quadrigemina—some fibres form connections with cells within this central grey matter. The fibres which proceed from the cortex through the corona radiata in a radiate direction constitute *Meynert's first projection system*. Besides these, the

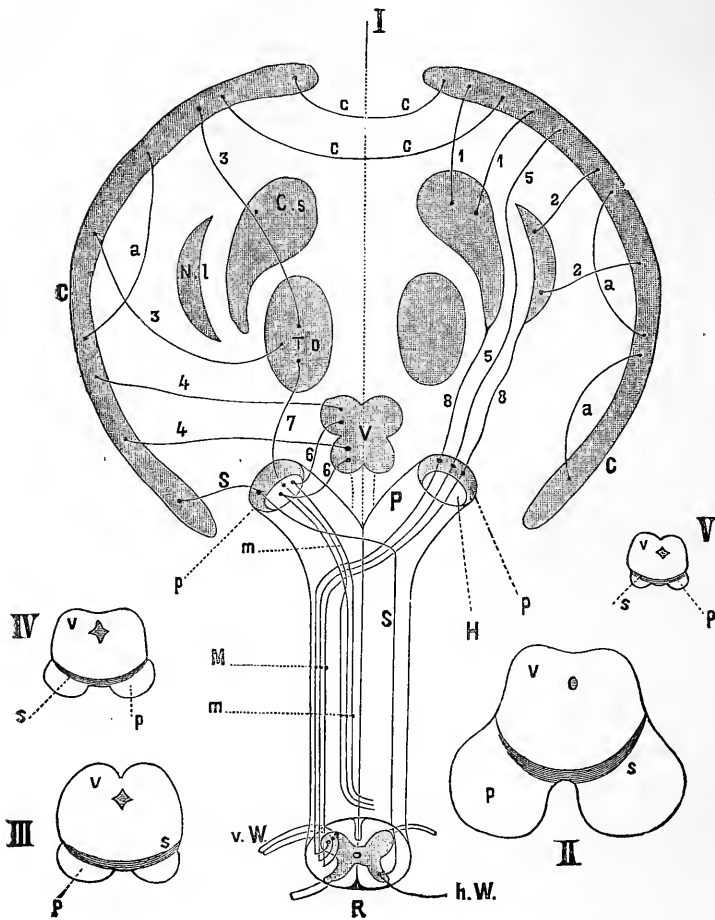

Fig. 341.

I, Scheme of the brain—C, C, cortex cerebri; C, s, corpus striatum; N, l, nucleus lenticularis; T, o, optic thalamus; v, corpora quadrigemina; P, pedunculus cerebri; H, tegmentum; and p, crusta; 1, 1, corona radiata of the corpus striatum; 2, 2, of the lenticular nucleus; 3, 3, of the optic thalamus; 4, 4, of the corpora quadrigemina; 5, 5, direct fibres to the cortex cerebri (Flechsig); 6, 6, fibres from the corpora quadrigemina to the tegmentum; m, further course of these fibres; 8, 8, fibres from the corpus striatum and lenticular nucleus to the crusta of the pedunculus cerebri; M, further course of these; S, S, course of the sensory fibres; R, transverse section of the spinal cord; v, W, anterior, and h, W, posterior roots; a, a, association system of fibres; c, c, commissural fibres. II, Transverse section through the posterior pair of the corpora quadrigemina and the pedunculi cerebri of man—p, crusta of the peduncle; s, substantia nigra; v, corpora quadrigemina, with a section of the aqueduct. III, The same of the dog; IV, of an ape; V, of the guinea-pig. [See p. 863.]

white substance also contains two other systems of fibres:—(a) *Commissural fibres*, such as the corpus callosum and the anterior commissure (c, c), which are supposed to connect the two hemispheres with each other; and (b) a *connecting or association* system, whereby two different areas of the same side are connected together (a, a). The ganglionic grey matter of the basal ganglia forms the first stage in the course of a large number of the fibres. When they enter the central grey matter they are *interrupted* in their course. According to Meynert, the corona radiata contains bundles of fibres from the corpus striatum, lenticular nucleus, optic thalamus, and corpora quadrigemina.

The second projection system consists of longitudinal bundles of fibres which proceed downwards and reaches the so-called "central tubular grey matter," which is the ganglionic grey matter reaching from the 3rd ventricle through the aqueduct of Sylvius, and the medulla oblongata, to the lowest part of the grey matter of the spinal cord. It lines the inner surface of the medullary tube. It is the second stage in the course of the fibres extending from the basal ganglia to the central tubular grey matter. The fibres of this system must obviously vary greatly in length.

With regard to the special distribution of the fibres of this system, it is assumed that the fibres descending from the lenticular nucleus and corpus striatum (8, 8) are collected into a special group, which course downwards through the upper part of the crista of the cerebral peduncle into the medulla oblongata, or only as far as the pons (Flechsig). In the same way a bundle proceeds from the thalamus (7), and also from the quadrigemina (6, 6) which descends through the *tegmentum* (H) of the cerebral peduncle. Both groups of fibres—those in the *tegmentum* as well as those in the crista, unite below in the spinal cord. The channels which run in the *crusta* are, according to Meynert, those for conducting the impulses that result in *voluntary movements*. According to Meynert, all the motor fibres pass through the lenticular nucleus and the corpus striatum, so that destruction of these channels causes *hemiplegia*, i.e., paralysis of voluntary movements on the opposite side of the body.

According to Wernicke, however, the lenticular nucleus and the caudate nucleus are not parts of the brain into which the fibres of the corona radiata pass from the brain; they are rather independent parts, analogous to the cortex itself, from which fibres proceed. These fibres enter the *tegmentum*, where they lie in relation with those fibres which proceed from the optic thalamus and corpora quadrigemina.

The fibres which proceed from the thalamus and corpora quadrigemina (6, 6 and 7) through the *tegmentum*, constitute Meynert's *reflex channels*, so that these grey masses are the centres for certain extensive co-ordinated reflexes. Mammals, after the destruction of the voluntary motor paths, still retain the power of executing very complex movements, so far as these depend on reflex discharges. These fibres run downwards in the crus on the same side (m), and very probably cross in the spinal cord itself.

The Third Projection System.—Lastly, from the central tubular grey matter there proceeds the third system, or the *peripheral nerves*, motor and sensory. They are more numerous than the fibres of the second system.

The Cerebellum and its Connections.—The cerebellum has grey matter on surface, and also in the form of scattered grey masses in its interior, such as the *corpus dentatum*. It is connected with the cerebrum—(1) by means of the *processus a cerebello ad testes* [or superior peduncles] (Fig. 342). It consists

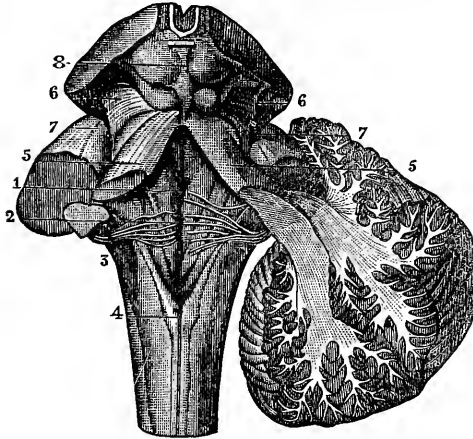

Fig. 342.

View of the floor of the fourth ventricle and the connections of the cerebellum. On the left side the three cerebellar peduncles have been cut short; on the right side the connections of the superior and inferior peduncles have been preserved, while the middle one has been cut short—1, median groove of the fourth ventricle with the fasciculi teretes; 2, the same groove with the striæ of the auditory nerve on each side emerging from it; 3, inferior peduncle or restiform body; 4, posterior pyramid and clava, with the calamus scriptorius above it; 5, superior peduncle; 6, fillet to the side of the crura cerebri; 7, lateral grooves of the crura cerebri; 8, corpora quadrigemina.

third left frontal convolution, which is connected with the function of speech, is supplied by a special branch of the Sylvian artery. Those areas of the frontal lobes, whose injury results in disturbance of the intelligence (Ferrier), are supplied by the anterior cerebral artery. Those regions of the cortex cerebri, whose injury, according to Ferrier, causes hemianæsthesia, are supplied by the posterior cerebral artery.

Course of the Voluntary Motor Fibres.—The course of the fibres which convey impulses for voluntary motion, the *psychomotor*, or “cortico-muscular” fibres, proceed from the motor regions (§ 375, 378, I.) of the cerebrum as follows (Charcot, Flechsig):—For motor nerves proceeding

of fibres from the corona radiata which pass into the tegmentum, and, after complete decussation, pass into the cerebellum; (2) the crura cerebelli ad pontem [or middle peduncle], and from the pons through the peduncle of the cerebrum to the hemispheres.

The cerebellum is also connected with the *spinal cord*—(1) with its *posterior column* (funiculus cuneatus and gracilis); and (2) with its *anterior column* (by the restiform body) [inferior peduncles]. Both halves of the cerebellum are united by the large *commissural fibres* of the pons.

[Hence, we have to consider *cerebro-spinal* and *cerebello-spinal tracts*.]

Cerebral Arteries.

—From a practical point of view, the distribution of the blood-vessels of the brain is important. The artery of the Sylvian fissure supplies the *motor* areas of the brain in animals; in man, the precentral lobule is supplied by a branch of the anterior cerebral artery (Duret). The region of the

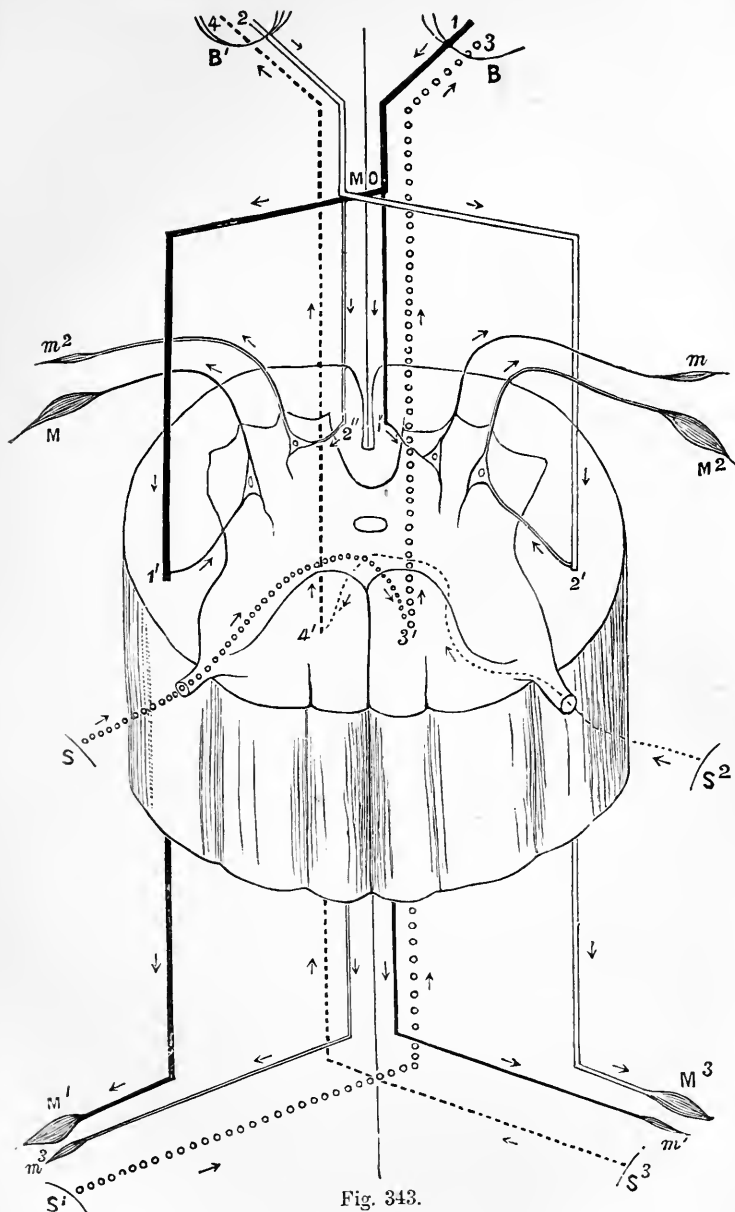

Fig. 343.

Diagram of a spinal segment as a spinal centre and conducting medium—B, right, B', left cerebral hemisphere; MO, lower end of medulla oblongata; 1, motor tract from the right hemisphere, the larger part decussating at MO, and passing down the lateral column of the cord on the opposite side to the muscles M and M'; 2, motor tract from the left hemisphere; S, S', sensitive areas on the left side of the body; 3', 3, the main sensory tract from the left side of the body. It decussates shortly after entering the cord. S², S³, sensitive areas, and 4', 4, tracts from the right side of the body. The arrows indicate the direction of the impulses (Bramwell). [Here all the sensory fibres are shown as crossing the cord.]

from the spinal cord, the motor fibres from the brain pass as the "*pyramidal tracts*" (§§ 359, 364) through the anterior two-thirds of the internal capsule, then through the crusta of the peduncle of the cerebrum, through the middle part of the under free circumference of the crusta, and through the pons on the same side to the anterior pyramid of the medulla oblongata. Here the greater part of the fibres crosses at the decussation of the pyramids to the opposite side, where they run downwards in the lateral column (as the *crossed pyramidal tracts*) to the level of the spinal cord, from whence the anterior nerve-roots for the muscles proceed. Before the fibres pass into the anterior root, they always first form connections with the multipolar nerve-cells of the anterior cornu, which, in fact, are introduced into the course of the conducting paths. A small part of the pyramidal tracts does not cross in the pyramids—the *direct pyramidal tract*—and descends on the same side in the anterior columns of the spinal cord, as the direct pyramidal tract, or the antero-internal column, and it remains upon the same side. These fibres, perhaps, supply those muscles of the trunk (*e.g.*, respiratory, abdominal, and perineal), which always act together on both sides. According to other observers, however, they cross to the other side of the cord through the anterior white commissure, and descend in the crossed pyramidal tract or pyramidal tract of the lateral column. The largest number of the crossed fibres pass to the motor nerves of the extremities.

[The *motor tract for voluntary impulses*, say from the motor area of the right hemisphere, is through the anterior part of the internal capsule, middle third of the crusta, pons, and medulla of the same side, where the greater part *crosses* to the left lateral column, then to the cells of the left anterior cornu, and from thence to the left anterior nerve-roots.]

In their passage through the brain, the paths for direct motor impulses are not interrupted anywhere in their course by ganglion cells, not even in the corpus striatum or pons. They pass in a direct uninterrupted course.

There are variations as to the number of fibres which cross at the pyramids (Flechsig). In some cases the usual arrangement is reversed, and in some rare instances there is no decussation, so that the pyramidal tracts from the brain remain on the same side. In this way we may explain the very rare cases where paralysis of the voluntary movements takes place on the *same* side as the lesion of the cerebrum (Morgagni, Pierret). [Usually, about 90 per cent. of the fibres decussate.]

The **motor cranial nerves** have the centres through which they are excited voluntarily, in the cortex cerebri (§ 378). The paths for such voluntary impulses also pass through the internal capsule and the crusta of the peduncle, where they lie in front of, and internal to, the pyramidal tracts (Flechsig). Their course is then directed towards

their nucleus, but this course is but little known. The hypoglossal nerve runs with the pyramidal tracts, and behaves like the anterior root of a spinal nerve (§§ 354, 357).

Course of the **Channel for Cutaneous Sensibility**.—From the cortical centre for cutaneous sensibility (the parietal area extending from the sulcus precentralis to the anterior margin of the occipital lobe) the conducting paths run through the posterior third of the internal capsule, which Charcot has called "*carrefour sensitiv*," between the pyramidal tracts and the outer bend of the knee in the internal capsule; they then enter the *tegmentum* of the peduncle, and are continued through the pons (Flechsig). With reference to the connection of this point with the sensory posterior roots, it is important to remember that the posterior columns of the cord, which carry a part of the posterior nerve-roots, pass into the grey nuclei of the funiculi graciles and cuneati at the upper end of the cord. From here they (greater part) *decussate in the upper decussation of the pyramids*, and thus reach the portion of the pons and tegmentum already mentioned. Some sensory fibres also run upwards in the cord in the mixed lateral tracts (Fig. 335, e, g).

A part of the sensory fibres from the skin, however, *decussates in the spinal cord*, and thus passes to the opposite side of the cord (Fig. 343). Hence, unilateral section of the spinal cord in man (and monkey—Ferrier) abolishes sensibility on the opposite side below the lesion; still the muscular sensibility remains intact. There is hyperæsthesia (§ 363) of the parts below the seat of the section on the side of the injury.

From experiments on mammals, Brown-Séquard concludes that the decussating sensory nerve-fibres pass to the opposite side within the cord at different levels; the lowest being the fibres for touch, then those for tickling and pain, and, highest of all, those which administer to sensations of temperature.

[Sensory impulses passing into the cord, say by a *right* posterior nerve-root, may pass to the cerebrum or cerebellum. If to the latter, the course probably is partly to the left direct cerebellar tract and posterior column to the restiform body, and then to the cerebellum. If to the cerebrum, they cross in the cord to the left lateral column, and also ascend in the grey matter to pass upwards in the left tegmentum into the posterior third of the internal capsule to the posterior cerebral convolutions. Some may pass through the optic thalamus (?) to reach the cerebrum.]

All the fibres, therefore, which connect the spinal cord with the grey matter of the brain, undergo a complete decussation in their course. Hence, in man a destructive affection of one hemisphere usually causes complete motor paralysis, and loss of sensibility on the

opposite side of the body. The fibres proceeding from the nuclei of origin of the **cranial nerves** also cross within the cranium.

Not unfrequently the motor paralysis and anæsthesia occur on the *same* side of head, in which case the lesion (due to pressure or inflammation) involves the cranial nerves lying at the base of the brain.

The position of decussation lies (1) in the spinal cord, (2) in the medulla oblongata, and lastly (3) in the pons. The decussation is complete in the peduncle.

Alternate Paralysis.—Gubler observed that unilateral injury to the pons caused paralysis of the facial nerve on the *same* side, but paralysis of the *opposite* half of the body. He concluded that the nerves of the trunk decussate *before* they reach the pons, while the facial fibres decussate within the pons. To these rare cases the name "*alternate hemiplegia*" is given. [When hæmorrhage takes place into the *lower* part of the lateral half of the pons, there may be alternate paralysis, but when the *upper* part of the lateral half is injured, the facial is paralysed on the same side as the body.]

The olfactory nerve is said not to decussate, while the optic nerve undergoes a partial decussation at the chiasma (§ 344). Some observers assert that the fibres of the trochlearis decussate at their origin.

366. The Medulla Oblongata.

[**Structure.**—In the medulla oblongata the fibres from the cord are rearranged, the grey matter is also much changed, while new grey matter is added. Each half of the medulla oblongata consists of the following parts from before backward: The *anterior pyramids*, *olivary body*, *restiform body*, and *posterior pyramid*, or funiculus gracilis (Figs. 344, 345, 346). By the divergence of the posterior pyramids and the restiform bodies, the floor of the fourth ventricle is exposed, with which the central canal of the cord communicates, as the latter gradually comes nearer to the posterior surface of the medulla. At the lower end of the medulla oblongata, on separating the anterior pyramids, we may see the decussation of the pyramids where the fibres cross over to the lateral columns of the cord. The *anterior pyramid* receives the direct pyramidal tract of the anterior column of the cord from its own side, and the crossed pyramidal tract from the lateral column of the cord of the opposite side (Fig. 344). The decussating fibres (crossed pyramidal tract) of the lateral column form the decussation of the pyramids. Most of the pyramidal fibres pass through the pons directly to the cerebrum, but a few fibres pass to the cerebellum, while a few join fibres proceeding from the olivary body to form the olivary fasciculus or fillet.

Of the fibres of the *lateral column* of the cord, some, the *direct cerebellar* tract, join the restiform body and go to the cerebellum; the *crossed pyramidal* fibres go to the anterior pyramid of the opposite side, while other fibres pass upwards beneath the olivary body, and appear in the floor of the fourth ventricle as the *fasciculus teres*.

The *posterior pyramid* of the oblongata is merely the upward continuation of the postero-median column, or funiculus gracilis of the cord. As it passes upwards at the medulla it broadens out, forming the *clava*, which tapers away above.

The *restiform body* consists of the upward continuation of the postero-external column or funiculus cuneatus of the cord. Between this fasciculus and the posterior pyramid there is another longitudinal eminence, which Schwalbe has

called the *funiculus of Rolando*, and these two together form the restiform body which, with the direct cerebellar tract applied to it and some *arcuate* fibres emerg-

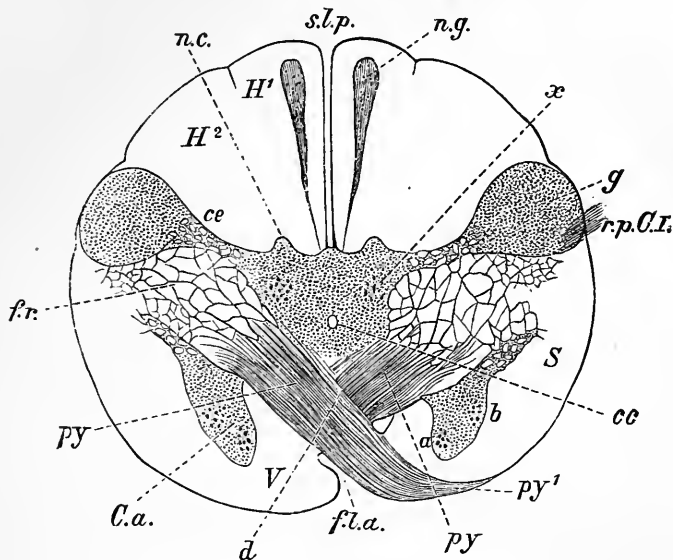

Fig. 344.

Section of the decussation of the pyramids—*f.l.a.*, anterior median fissure, displaced laterally by the fibres decussating at *d*; *V*, anterior column; *C.a.*, anterior cornu, with its nerve-cells, *a*, *b*; *cc*, central canal; *S*, lateral column; *f.r.*, formatio reticularis; *ce*, neck, and *g*, head of the posterior cornu; *r.p.C.I.*, posterior root of the first cervical nerve; *nc*, first indication of the nucleus of the funiculus cuneatus; *ng*, nucleus (clava) of the funiculus gracilis; *H¹*, Funiculus gracilis; *H²*, Funiculus cuneatus; *s.l.p.*, posterior median fissure; *x*, groups of ganglionic cells in the base of the posterior cornu $\times 6$ (Schwalbe).

ing from the anterior median fissure, crosses the anterior pyramids and olivary body, and passes to the cerebellum on the same side, constituting its inferior peduncle.]

[The **grey matter** of the medulla is largely a continuation of that of the cord, although it is arranged differently. As the fibres from the lateral column of the cord pass over to form part of the anterior pyramid of the medulla on the opposite side, they traverse the grey matter and thus cut off the tip of the anterior cornu, which is also pushed backwards by the olivary body, and exists as a distinct mass, the *nucleus lateralis* (Fig. 345, *nl*). Part of the anterior grey matter also appears in the floor of the fourth ventricle as the eminence of the fasciculus teres, and from part of it springs the hypoglossal nerve (Fig. 346, *xii*). The posterior cornu is also broken up and is thrown outwards, its caput giving rise to part of the elevation seen on the surface and described as the funiculus of Rolando, while part of the base now greatly enlarged forms the grey matter in the funiculus gracilis (Fig. 344, *ng*) and funiculus cuneatus (Fig. 344, *nc*). The grey matter of the posterior grey cornu appears in the floor of the fourth ventricle above where the central canal

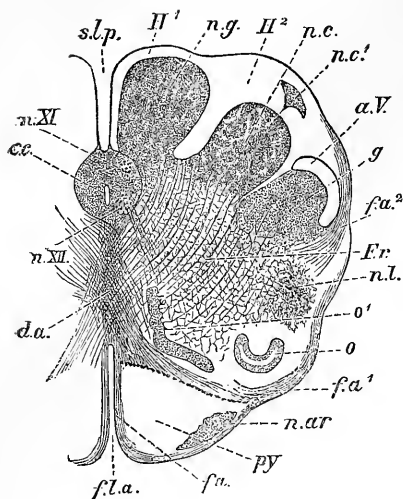

Fig. 345.

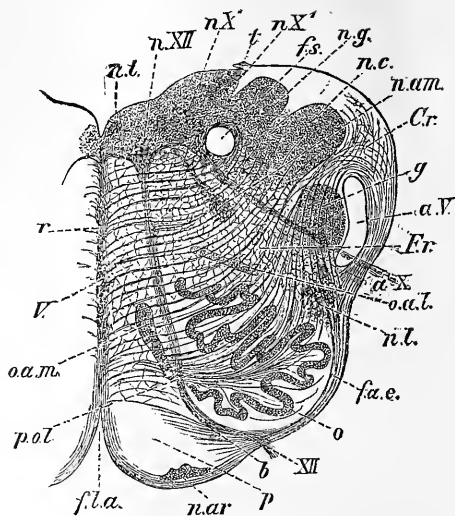

Fig. 346.

Fig. 345.—Section of the medulla oblongata at the so-called upper decussation of the pyramids—*fl.a.*, anterior, *sl.p.*, and posterior median fissure; *n.XI*, nucleus of the accessorius vagi; *n.XII*, nucleus of the hypoglossal; *da.*, the so-called superior or anterior decussation of the pyramids; *py*, anterior pyramid; *n.Ar*, nucleus arciformis; *O¹*, median parolivary body; *O*, beginning of the nucleus of the olivary body; *n.l.*, nucleus of the lateral column; *Fr.*, formatio reticularis; *g*, substantia gelatinosa, with (*a.V*) the ascending root of the trigeminus; *nc*, nucleus of the funiculus cuneatus; *nc¹*, external nucleus of the funiculus cuneatus; *ng*, nucleus of the funiculus gracilis (or clava); *H¹*, funiculus gracilis; *H²*, funiculus cuneatus; *cc*, central canal; *fa*, *fa¹*, *fa²*, external arciform fibres $\times 4$.

Fig. 346.—Section of the medulla oblongata through the olivary body; *n.XII*, nucleus of the hypoglossal; *n.X*, *n.X¹*, more or less cellular parts of the nucleus of the vagus; *XII*, hypoglossal nerve; *X*, vagus; *n.am*, nucleus ambiguus; *n.l.*, nucleus lateralis; *o*, olivary nucleus; *oal*, external, and *oam*, internal parolivary body; *fs*, the round bundle, or funiculus solitarius; *Cr.*, restiform body; *p*, anterior pyramid, surrounded by arciform fibres; *fae*, *pol*, fibres proceeding from the olive to the raphe (pedunculus olivæ); *r*, raphe $\times 4$.

opens into it, as the nuclei of the spinal accessory, vagus, and glosso-pharyngeal nerves. The medulla also contains the nucleus for the auditory nerve. There is a superadded mass of grey matter not represented in the cord, that of the *olivary body* enclosing a nucleus, the *corpus dentatum*, with its wavy strip of grey matter containing many multipolar nerve-cells. The grey matter is covered on the surface by longitudinal and transverse fibres. There are other smaller masses of grey matter, the internal and external parolivary bodies, which lie to the outer and inner side of the corpus dentatum.]

Functions.—The medulla oblongata, which connects the spinal cord with the brain, has many points of resemblance with the former. In its numerous *centres*. for *simple reflexes* are present similar to the nerve-centres in the spinal cord, *e.g.*, closure of the eyelids. There are other

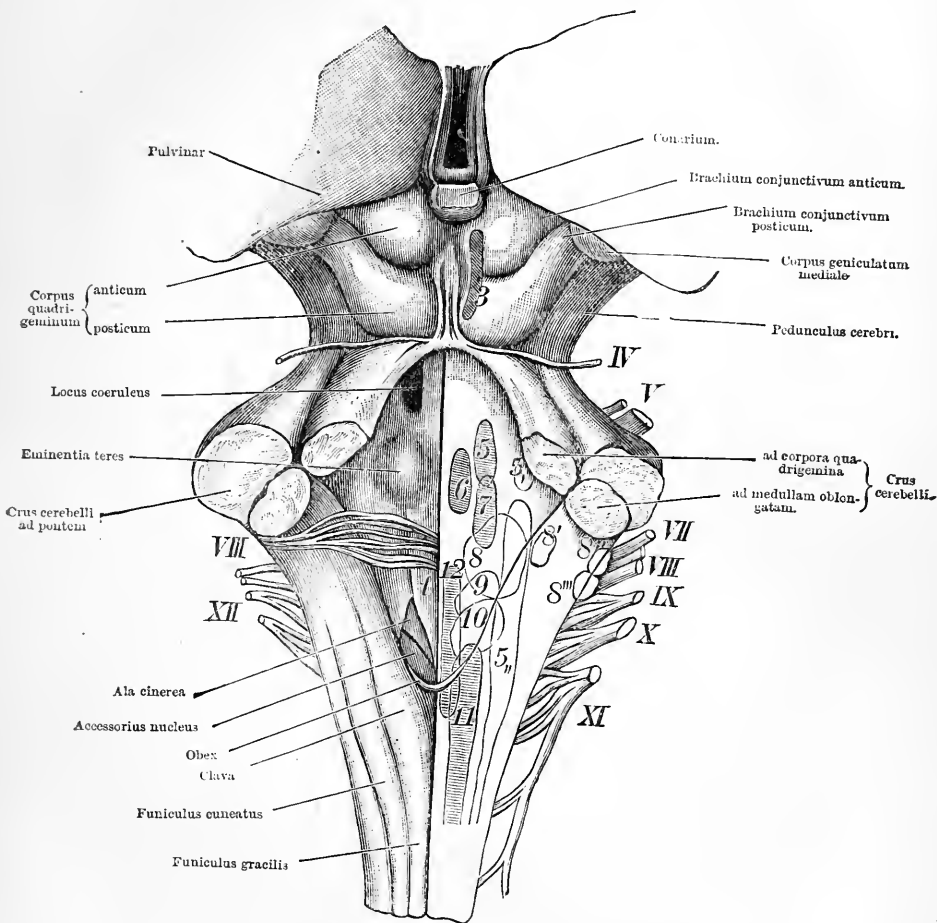

Fig. 347.

Medulla oblongata, with the corpora quadrigemina (enlarged)—The numbers *IV.-XII.* indicate the superficial origins of the cranial nerves, while those (*3-12*) indicate their deep origin, *i.e.*, the position of their central nuclei; *t*, funiculus teres.

centres present which seem to *dominate* or *control* similar centres placed in the cord—*e.g.*, the great vaso-motor centre, the sweat-secreting, pupil-dilating centres, and the centre for combining the reflex movements of the body. Some of the centres are capable of being excited

reflexly (§ 358, 2), while others are automatic (§ 358, 3). The *normal functions* of these centres depend upon the exchanges of gases effected by the circulation of the blood through the medulla. If this *gaseous exchange* be interrupted or interfered with, as by asphyxia, sudden anæmia, or venous congestion, these centres are first excited, and exhibit a condition of increased excitability, and, if they are over-stimulated, at last they are paralysed. An excessive *temperature* also acts as a stimulus. All the centres, however, are not active at the same time, and they do not all exhibit the same degree of excitability. Normally, the respiratory centre and the vaso-motor centre are continually in a state of rhythmical activity. In some animals the inhibitory centre of the heart remains continually non-excited, in others it is stimulated very slightly under normal conditions, simultaneously with the stimulation of the respiratory centre and only during inspiration. The spasm centre is not stimulated under normal conditions, and during intra-uterine life, the respiratory centre remains quiescent. The medulla oblongata, therefore, contains a collocation of nerve-centres which are essential for the maintenance of life, as well as various conducting paths of the utmost importance. We shall treat of the reflex, and afterwards of the automatic centres.

367. Reflex Centres of the Medulla Oblongata.

The medulla oblongata contains a number of reflex centres, which minister to the discharge of a large number of co-ordinated movements.

1. **Centre for the Closure of the Eyelids.**—The sensory branches of the 5th cranial nerve to the cornea, conjunctiva, and the skin in the region of the eye are the *afferent* nerves. They conduct impulses to the medulla oblongata, where they are transferred to, and excite part of, the centre of the facial nerve, and through branches of the facial the *efferent* impulses are conveyed to the orbicularis palpebrarum. The centre lies close to the calamus scriptorius (Exner).

The reflex closure of the eyelids always occurs on *both* sides, but closure may be produced voluntarily on one side (winking). When the stimulation is *strong*, the corrugator and other groups of muscles which raise the cheek and nose towards the eye may also contract, and so form a more perfect protection and closure of the eye. Intense stimulation of the retina causes closure of the eyelids.

2. **Centre for Sneezing.**—The *afferent* channels are the internal nasal branches of the trigeminus and the olfactory, the latter in the case of intense odours. The *efferent* or motor paths lie in the nerves for the muscles of expiration (§ 120, 3, and § 347, II.). Sneezing cannot be performed voluntarily.

3. **Centre for Coughing**, according to Kohts, is placed a little above the inspiratory centre; the *afferent* paths are the sensory branches of the vagus (§ 352, 5, a). The *efferent* paths lie in the nerves of expiration and those that close the glottis (§ 120, 1).

4. **Centre for the Movements of Sucking and Mastication**.—The *afferent* paths lie in the sensory branches of the nerves of the mouth and lips (2nd and 3rd branches of the trigeminus and glosso-pharyngeal). The *efferent* nerves for *suction* (§ 152) are:—Facial for the lips, hypoglossal for the tongue, the inferior maxillary division of the trigeminus for the muscles which elevate and depress the jaw. For the movements of *mastication* (§ 153) the same nerves are in action, but when food passes within the dental arch, the hypoglossal is concerned in the movements of the tongue, and the facial for the buccinator.

5. **Centre for the Secretion of Saliva** (p. 290), which lies in the floor of the 4th ventricle (Eckhard).—Stimulation of the medulla oblongata causes a profuse secretion of saliva, when the chorda tympani and glosso-pharyngeal nerves are intact, a much feebler secretion when the nerves are divided, and no secretion at all when the cervical sympathetic is extirpated at the same time (Grützner).

6. **Centre for Swallowing** in the floor of the 4th ventricle (§ 156).—The afferent paths lie in the sensory branches of the nerves of the mouth, palate, and pharynx (2nd and 3rd branches of the trigeminus, glosso-pharyngeal, and vagus); the *efferent* channels in the motor branches of the pharyngeal plexus (§ 352, 4).

According to Steiner, every time we swallow there is a slight stimulation of the respiratory centre, resulting in a slight contraction of the diaphragm. [Kronecker has shown that if a glass of water be sipped slowly, the action of the cardio-inhibitory centre is interfered with reflexly, so that the heart beats much more rapidly.]

7. **Centre for Vomiting** (§ 158).—The relation of certain branches of the vagus to this act are given at § 352, 2, and 12, d.

8. **The upper centre for the dilator pupillæ muscle**, the smooth muscles of the orbit and the eyelids lies in the medulla oblongata. The fibres pass out partly in the trigeminus (p. 793, 3), partly in the lateral columns of the spinal cord as far down as the cilio-spinal region, and pass out by the two lowest cervical and the two upper dorsal nerves into the cervical sympathetic (§ 356, A, 1). The centre is normally excited *reflexly* by shading the retina, *i.e.*, by diminishing the amount of light admitted into the eye. It is directly excited by the circulation of dyspnoëic blood in the medulla. (The centre for *contracting* the pupil is referred to at § 345 and § 392.)

9. There is a subordinate centre in the medulla oblongata, which seems to be concerned in bringing the various reflex centres of the

cord into relation with each other. Owsjannikow found that, on dividing the medulla 6 mm. above the *calamus scriptorius* (rabbit), the *general* reflex movements of the body still occurred, and the anterior and posterior extremities participated in such general movements. If, however, the section was made 1 mm. nearer the *calamus*, only local partial reflex actions occurred (§ 360, III., 4); [thus, on stimulating the hind-leg, the fore-legs did not react, the *transference* of the reflex was interfered with]. The centre reaches upwards to slightly above the lowest third of the *oblongata*.

Pathological.—The medulla *oblongata* is sometimes the seat of a typical disease, known as **bulbar paralysis**, or glosso-pharyngo-labial paralysis (Duchenne, 1860), in which there is a progressive invasion of the different nerve-nuclei (centres) of the cranial nerves which arise within the medulla, these centres being the motor portions of an important reflex apparatus. Usually the disease begins with paralysis of the *tongue*, accompanied by fibrillar contractions (p. 640), whereby speech, formation of the food into a bolus, and swallowing are interfered with (§ 354). The secretion of thick viscid saliva points to the impossibility of secreting a thin watery *facial saliva* (§ 145, A), owing to paralysis of this nerve-nucleus. Swallowing may be impossible, owing to paralysis of the pharynx and palate. This interferes with the formation of certain *consonants* (§ 318, C); the speech becomes nasal, while fluid, and solid food often passes into the nose. Then follows paralysis of the branches of the facial to the lips, and there is a characteristic expression of the mouth “as if it were frozen.” All the muscles of the face may be paralysed; sometimes the *laryngeal muscles* are paralysed, leading to the loss of voice, and the entrance of food into the windpipe. The *heart beats* are often *slowed*, pointing to stimulation of the cardio-inhibitory fibres (arising from the *accessorius*). Attacks of *dyspnœa*, like those following paralysis of the recurrent nerves (§ 313, II, 1, and § 352, 5, b), and death may occur. Paralysis of the muscles of mastication, contraction of the pupil, and paralysis of the *abducens* are rare.

368. The Respiratory Centre and the Innervation of the Respiratory Apparatus.

The **respiratory centre** lies in the medulla *oblongata* (Legallois), behind the point of origin of the *vagi*, on both sides of the posterior aspect of the apex of the *calamus scriptorius*, between the nuclei of the *vagus* and *accessorius* (Flourens), and was named by Flourens the *vital point*, or *nœud vital*. The centre is double, one for each side, and it may be separated by means of a longitudinal incision (Longet), whereby the respiratory movements continue symmetrically on both sides. If *one vagus* be *divided*, respiration on that side is *slowed*. If *both vagi* be *divided*, the respirations become much *slower* and *deeper*, but the respiratory movements are symmetrical on both sides. Stimulation of the *central* end of one *vagus*, both being divided, causes an arrest of the respiration only on the same side, the other side continues to breathe. The same result is obtained by stimulation of the

trigemini on one side (Langendorff). When the centre is divided transversely on one side, the respiratory movements on the *same* side cease (Schiff).

Anatomical.—According to Giercke, Heidenhain, and Langendorff, those parts of the medulla oblongata, whose destruction causes cessation of the respiratory movements, are not grey cellular substance, but only single or double strands of nervous matter running downwards in the substance of the medulla oblongata. These strands are said to arise partly from the roots of the vagus, trigeminus, spinal accessory, and glosso-pharyngeal (Meynert), forming connections by means of fibres with the other side, and descending as far downwards as the cervical enlargement of the spinal cord (Goll). According to this view, this strand represents an *inter-central* band connecting the spinal cord (the place of origin of the motor respiratory nerves) with the nuclei of the above-named cranial nerves.

Most probably the *dominating* respiratory centre lies in the medulla oblongata, and upon it depends the rhythm, and symmetry of the respiratory movements; but, in addition, other and *subordinate* centres are placed in the spinal cord, and these are governed by the oblongata centre (p. 362). If the spinal cord be divided in newly-born animals—dog, cat—below the medulla oblongata, respiratory movements of the thorax are sometimes observed (Brachet, 1835, Lautenbach, and Langendorff).

Cerebral Inspiratory Centre.—According to Christiani, there is a *cerebral inspiratory centre* in the optic thalamus, in the floor of the 3rd ventricle, which is stimulated through the optic and auditory nerves, even after extirpation of the cerebrum and corpora striata; when it is stimulated directly, it deepens and accelerates the *inspiratory* movements, and may even cause a standstill of the respiration in the inspiratory phase. This inspiratory centre may be extirpated. After this operation, an *expiratory* centre is active in the substance of the anterior pair of the corpora quadrigemina, not far from the aqueduct of Sylvius. Lastly, Marten and Booker describe a second cerebral *inspiratory* centre in the posterior pair of the corpora quadrigemina. These three centres are connected with the centres in the medulla oblongata.

Inspiratory and Expiratory Centres.—The respiratory centre consists of *two* centres, which are in a state of activity alternately—an *inspiratory* and an *expiratory* centre (Fig. 348); each one forming the motor central point for the acts of inspiration and expiration (§ 112).

The centre is *automatic*, for, after section of all the sensory nerves which can act reflexly upon the centre, it still retains its activity.

The degree of excitability and the stimulation of the centre depend upon the state of the blood, and chiefly upon the amount of the blood-gases, the O and CO₂ (J. Rosenthal).

According to the condition of the centre, there are several well-recognised respiratory conditions:—

1. **Apnœa.**—Complete cessation of the respiration constituting *apnœa*, *i.e.*, cessation of the respiratory movements, owing to the absence of the proper stimulus, due to the blood being saturated with O, and poor in CO₂. Such blood saturated with O fails to stimulate the centre, and hence the respiratory muscles are quiescent. This seems to be the condition in the fœtus during intra-uterine life. If air be vigorously and rapidly forced into the lungs of an animal by artificial respiration, the animal will cease to breathe for a time after cessation of the artificial respiration (Hook, 1667), the blood being so arterialised that it no longer stimulates the respiratory centre. If a person take a series of rapid, deep respirations, his blood becomes surcharged with oxygen, and long “*apnœic pauses*” occur.

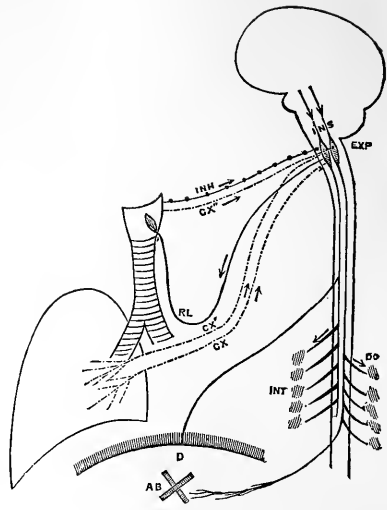

Fig. 348.

Scheme of the chief respiratory nerves, after Rutherford—*ins*, inspiratory, and *exp*, expiratory centre—motor nerves are in smooth lines. Expiratory motor nerves to abdominal muscles, *ab*; to muscles of back, *do*. Inspiratory motor nerves—*ph*, phrenic to diaphragm, *d*; *int*, intercostal nerves; *rl*, recurrent laryngeal to larynx; *ex*, pulmonary fibres of vagus that excite inspiratory centre; *ex'*, pulmonary fibres that excite expiratory centre; *ex''*, fibres of superior laryngeal nerves that excite expiratory centre; *inh*, fibres of superior laryngeal that inhibit the inspiratory centre.

Apnœic Blood.—A. Ewald found that the arterial blood of apnœic animals was completely saturated with O, while the CO₂ was diminished; the venous blood contained less O than normal—this latter condition, being due to the apnœic blood causing a considerable fall of the blood-pressure and consequent slowing of the blood-stream, so that the O can be more completely taken from the blood in the capillaries (Pflüger). The amount of O used on the whole in apnœa is not increased (p. 259). Gad remarks that during forced *artificial respiration*, the pulmonary alveoli contain a very large amount of atmospheric air; hence, they are able to arterialise the blood for a longer time, thus diminishing the necessity for respiration.

2. **Eupnœa.**—The normal stimulation of the respiratory centre, *eupnœa*, is caused by the blood in which the amount of O and CO₂ does not exceed the normal limits (§§ 35 and 36).

3. **Dyspnœa.**—All conditions which diminish the O and increase the CO₂ in the blood circulating through the medulla and respiratory centre, cause acceleration and deepening of the respirations, which may ultimately pass into vigorous and laboured activity of all the respiratory muscles, constituting *dyspnœa*, when the difficulty of breathing is very great (§ 134).

For the changes in the rhythm see § 111.

4. **Asphyxia.**—If blood, abnormal as regards the amount and quality of its gases, continues to circulate in the medulla, or if the condition of the blood become still more abnormal, the respiratory centre is *over-stimulated*, and it is *exhausted*. The respirations are diminished both in number and depth, and they become feeble and gasping in character; ultimately the movements of the respiratory muscles cease, and the heart itself soon ceases to beat. This constitutes the condition of *asphyxia*; and, if it be continued, death from **suffocation** takes place. (Langendorff asserts that in asphyxiated frogs, the muscles and grey nervous substance have an acid reaction.) If the conditions causing the abnormal condition of the blood be removed, the asphyxia may be prevented under favourable circumstances, especially by using artificial respiration; the respiratory muscles begin to act and the heart begins to beat, so that the normal eupnœic stage is reached through the condition of dyspnœa. If the venous condition of the blood be produced slowly and very gradually, asphyxia may take place without there being any symptoms of dyspnœa, as occurs when death takes place quietly and very gradually (§ 324, 5).

Causes of Dyspnœa.—1. *Direct limitation of the activity of the respiratory organs*; diminution of the respiratory surface by inflammation, acute œdema (p. 75), or collapse of the alveoli, occlusion of the capillaries of the alveoli, compression of the lungs, entrance of air into the pleura, obstruction or compression of the windpipe. 2. *Obstruction to the entrance of the normal amount of air* by strangulation, or enclosure in an insufficient space. 3. *Enfeblement of the circulation*, so that the medulla oblongata does not receive a sufficient amount of blood; in degeneration of the heart, valvular cardiac disease, and artificially by ligature of the carotid and vertebral arteries (Kussmaul and Tenner), or by preventing the free efflux of venous blood from the skull, or by the injection of a large quantity of air or indifferent bodies into the right heart. 4. *Direct loss of blood*, which acts by arresting the exchange of gases in the medulla (J. Rosenthal). This is the cause of the “biting or snapping at the air” manifested by the decapitated heads of young animals, e.g., kittens. [The phenomenon is well marked in the head of a tortoise separated from the body—W. Stirling.]

All these factors act rapidly upon the respiratory activity, and at first the respirations are deeper and more rapid, and afterwards the respiratory movements become more violent and general convulsions occur, ending with expiratory spasm, which is followed by a stage of cessation of the respiration and complete relaxation. Before death takes place, there are usually a few “snapping” or gasping efforts at inspiration (Hogyes, Sigm. Mayer—p. 234).

Condition of the Blood-Gases.—As a general rule, in the production of dyspnoea, the want of O and the excess of CO₂ act simultaneously (Pflüger and Dohmen), but each of these alone may act as an efficient cause. According to Bernstein, blood containing a small amount of O acts chiefly upon the inspiratory centre, and blood rich in CO₂, on the expiratory centre. Dyspnoea, from want of O, occurs during respiration in a space of *moderate* size (§ 133), in spaces where the tension of the air is diminished, and by breathing in indifferent gases or those containing no free O. When the blood is freely ventilated with N or H, the amount of CO₂ in the blood may even be diminished, and death occurs with all the signs of asphyxia (Pflüger). Dyspnoea, from the blood being overcharged with CO₂, occurs by breathing air containing much CO₂ (§ 133). Air containing much CO₂ may cause dyspnoea, even when the amount of O in the blood is greater than that in the atmosphere (Thiry). The blood may even contain more O than normal (Pflüger).

An **increased temperature** increases the activity of the respiratory centre (§ 214, II., 3). This occurs when blood, warmer than natural, flows through the the brain, as Fick and Goldstein observed when they placed the exposed carotids in warm tubes, so as to heat the blood passing through them. In this case the heated blood acts directly upon the brain, the medulla and the cerebral respiratory centres (Gad). Direct cooling diminishes the excitability (Frédéricq). When the temperature is increased, vigorous artificial respiration does not produce apnoea, although the blood is highly arterialised (Ackermann). Emetics act in a similar manner (Hermann and Grimm).

Electrical stimulation of the medulla oblongata separated from the brain, discharges respiratory movements (Kronecker and Marckwald), or increases those already present. Langendorff found that electrical, mechanical, or chemical (salts) stimulation usually caused an expiratory effect, while stimulation of the cervical spinal cord (subordinate centre) gave an inspiratory effect. According to Laborde, a superficial lesion in the region of the calamus scriptorius causes standstill of the respiration for a few minutes. If the peripheral end of the vagus be stimulated so as to arrest the action of the heart, the respirations also cease after a few seconds. Arrest of the heart's action causes a temporary anæmia of the medulla, in consequence of which its excitability is lowered, so that the respirations cease for a time (Langendorff).

Action on the Centre.—The respiratory centre, besides being capable of being stimulated *directly*, may be influenced by the *will*, and also *reflexly* by stimulation of a number of afferent nerves.

1. By a voluntary impulse we may arrest the respiration for a short time, but only until the blood becomes so venous as to excite the centre to increased action. The number and depth of the respirations may be voluntarily increased for a long time, and we may also voluntarily change the rhythm of respiration.

2. The respiratory centre may be influenced **reflexly** both by fibres which excite it to *increased action* and by others which *inhibit* its action. (*a.*) The *exciting* fibres lie in the pulmonary branches of the vagus, in the optic, auditory, and sensory cutaneous nerves, and normally their action overcomes the action of the inhibitory fibres. Thus a cold bath deepens the respirations, and causes a moderate acceleration of the pulmonary ventilation (Speck).

Section of both vagi causes *slowing* of the respiratory movements, owing to the cutting off of those impulses which, under normal condi-

tions, pass from the lungs to excite the respiratory centre. The amount of air taken in and CO_2 given off, however, is not changed. The inspiratory efforts are more vigorous and not so purposive (Gad). *Weak* tetanising currents applied to the *central* end of the vagus cause acceleration of the respirations (Budge, Eckhard); while, at the same time, the efforts of the respiratory muscles may be increased or diminished, or remain unchanged (Gad). *Strong* tetanising currents cause stand-still of the respiration in the inspiratory phase (Traube), or expiratory phase (Budge, Burkart). *Single* induction shocks have no effect (Marckwald and Kronecker).

Wedenski and Heidenhain have recently reinvestigated the effect of stimulation of the vagus upon the respiration. They find that a *temporary weak* electrical stimulus applied to the central end of the vagus, at the beginning of inspiration (rabbit), affects the depth of the succeeding inspirations, while a similar strong stimulus affects also the depth of the following expirations. If the stimulus be applied just at the commencement of expiration, stronger stimuli being required in this case, there is a diminution of the expiration and of the following inspiration. *Continued* tetanic stimulation of the vagus may cause decrease in the depth of the expirations, or at the same time alteration in the depth of the inspirations, without affecting the respiratory rhythm; when the stimulus is *stronger*, inspiration and expiration are diminished with or without alteration of the frequency, and with the *strongest* stimuli respirations cease, either in the inspiratory or expiratory phase.

(b.) The inhibitory nerves which affect the respiratory centre, lie in the superior laryngeal nerve (Rosenthal), and also in the inferior (Pflüger and Burkart, Hering, Breuer) (Fig. 348, *inh*).

According to Langendorff, direct electrical, mechanical, or chemical stimulation of the centre may arrest respiration, perhaps, in consequence of the stimulus affecting the central ends of these inhibitory nerves, where they enter the ganglia of the respiratory centre.

Stimulation of the superior or inferior laryngeal nerves (b.) or their *central* ends causes slowing, and even arrest of the respiration (in expiration—Rosenthal). Arrest of the respiration in expiration is also caused by stimulation of the nasal (Hering and Kratschmer) and ophthalmic branches of the trigeminus (Christiani); stimulation of the pulmonary branches of the vagus by breathing irritating gases (Knoll), although other gases cause stand-still in inspiration. Chemical stimulation of the trunk of the vagus, by dilute solutions of sodic carbonate, causes expiratory inhibition of the respiration; and mechanical stimulation, rubbing with a glass rod, inspiratory inhibition (Knoll). The stimulation of sensory cutaneous nerves, especially of the chest and abdomen, as occurs on taking a cold douche, stimulation of the splanchnics (T. C. Graham), cause stand-still in expiration (Schiff, Falk), the first cause often giving rise to temporary clonic contractions of the respiratory

muscles. The respirations are often slowed to a very great extent by pressure upon the brain, [whether the pressure be due to a depressed fracture, or effusion into the ventricles and subarachnoid space]. The respiration may be greatly oppressed and stertorous.

The amount of *work* done by the respiratory muscles is altered during the reflex slowing of the respiratory muscles, the work being increased during slow respiration, owing to the ineffectual inspiratory efforts (Gad). The *volume* of the gases which passes through the lungs during a given time remains unchanged (Valentin), and the gaseous exchanges are not altered at first (Voit and Rauber).

Automatic Regulation of the Respiratory Centre.—Under normal circumstances, it would seem that the pulmonary branches of the vagus act upon the two respiratory centres, so as to set in action what has been termed the *self-adjusting* mechanism; thus, the inspiratory dilatation of the lungs stimulates mechanically the fibres which reflexly excite the *expiratory* centre, while the diminution of the lungs during expiration excites the nerves which proceed to the *inspiratory* centre (Hering and Breuer).

Discharge of the First Respiration.—The foetus is in an apnoeic condition until birth, when the umbilical cord is cut. During intra-uterine life, O is freely supplied to it by the activity of the placenta. All conditions which interfere with this due supply of O, as compression of the umbilical vessels and prolonged labour pains, cause a decrease of the O and an increase of the CO₂ in the blood, so that the condition of the foetal blood is so altered as to stimulate the respiratory centre, and thus the impulse is given for the discharge of the first respiratory movement (Schwartz). A foetus still within the unopened foetal membranes may make respiratory movements (Vesalius, 1542). If the exchange of gases be interrupted to a sufficient extent, dyspnœa and ultimately death of the foetus may occur. If, however, the venous condition of the mother's blood develops very slowly, as in cases of quiet, slow death of the mother, the medulla oblongata of the foetus may gradually die without any respiratory movement being discharged (§ 324, 5).

According to this view, the respiratory movements are due to the direct action of the dyspnœic blood upon the medulla oblongata. Death of the mother acts like compression of the umbilical cord. In the former case, the maternal venous blood robs the foetal blood of its O, so that death of the foetus occurs more rapidly (Zuntz). If the mother be *rapidly* poisoned with CO (§ 17), the foetus may live longer, as the CO-hæmoglobin of the maternal blood cannot take any O from the foetal blood (§ 16—Hogyes). In slow poisoning, the CO passes into the foetal blood (Gréhant and Quinquand).

In many cases, especially in cases of very prolonged labour, the excitability of the respiratory centre may be so diminished, that after birth, the dyspnœic condition of the blood alone is not sufficient to

excite respiration in a normal rhythmical manner. In such cases *stimulation* of the *skin* also acts—*e.g.*, partly by the cooling produced by the evaporation of the amniotic fluid from the skin. When air has entered the lungs by the first respiratory movements, the air within the lungs also excites the pulmonary branches of the vagus (Pflüger), and thus the respiratory centre is stimulated reflexly to increased activity.

According to v. Preuschen's observations, stimulation of the cutaneous nerves is more effective than that of the pulmonary branches of the vagus. In animals which have been rendered apnoëic by free ventilation of their lungs, respiratory movements may be discharged by strong cutaneous stimuli, *e.g.*, dashing on of cold water. The mechanical stimulation of the skin by friction or sharp blows, or the application of a cold douche, excites the respiratory centre.

Artificial Respiration in Asphyxia.—In cases of suspended animation, *artificial respiration* must be performed. The first thing to be done is to remove any foreign substance from the respiratory passages (mucus or œdematous fluids) in the newly-born or asphyxiated. In doubtful cases, open the trachea and suck out any fluid by means of an elastic catheter (v. Hüter). Recourse must in all cases be had to artificial respiration. There are several methods of dilating and compressing the chest so as to cause an exchange of gases. One method is to compress the chest rhythmically with the hands.

[**Marshall Hall's Method.**—“After clearing the mouth and throat, place the patient on the face, raising and supporting the chest well on a folded coat or other article of dress. Turn the body very gently on the side and a little beyond, and then briskly on the face, back again, repeating these measures cautiously, efficiently, and perseveringly, about fifteen times in the minute, or once every four or five seconds, occasionally varying the side. By placing the patient on the chest, the weight of the body forces the air out; when turned on the side, this pressure is removed, and air enters the chest. On each occasion that the body is replaced on the face, make uniform but efficient pressure with brisk movement on the back between and below the shoulder-blades or bones on each side, removing the pressure immediately before turning the body on the side. During the whole of the operations let one person attend solely to the movements of the head and of the arm placed under it.”]

[**Sylvester's Method.**—“Place the patient on the back on a flat surface, inclined a little upwards from the feet; raise and support the head and shoulders on a small firm cushion or folded article of dress placed under the shoulder-blades. Draw forward the patient's tongue, and keep it projecting beyond the lips; an elastic band over the tongue and under the chin will answer this purpose, or a piece of string or tap may be tied round them, or by raising the lower jaw, the teeth may be made to retain the tongue in that position. Remove all tight clothing from about the neck and chest, especially the braces.”]

“*To Imitate the Movements of Breathing.*—Standing at the patient's head, grasp the arms just above the elbows, and draw the arms gently and steadily upwards above the head, and *keep them stretched* upwards for two seconds. By this means air is drawn into the lungs. Then turn down the patient's arms, and press them gently and firmly for two seconds against the sides of the chest. By this means air is pressed out of the lungs. Repeat these measures alternately, deliberately, and perseveringly about fifteen times in a minute, until a spontaneous effort to respire is perceived, immediately upon which cease to imitate the movements of breathing, and proceed to *induce circulation and warmth.*”]

Howard advises rhythmical compression of the chest and abdomen by sitting like

a rider astride of the body, while Schüller advises that the lower ribs be seized from above with both hands and raised, whereby the chest is dilated, especially when the thigh is pressed against the abdomen to compress the abdominal walls. The chest is compressed by laying the hands flat upon the hypochondria. Artificial respiration acts favourably by supplying O to, as well as removing CO₂ from, the blood; further, it aids the movement of the blood within the heart and in the large vessels of the thorax. If the action of the heart has ceased, recovery is impossible. In asphyxiated newly-born children, we must not cease to perform artificial respiration too soon. Even when the result appears hopeless, we ought to persevere. Pflüger and Zuntz observed that the reflex excitability of the fetal heart continued for several hours after the death of the mother.

Resuscitation by compressing the heart. Böhm found that in the case of cats poisoned with potash salts or chloroform, or asphyxiated, so as to arrest respiration and the action of the heart—even for a period of forty minutes—and even when the pressure within the carotid had fallen to zero, he could restore animation by *rhythmical compression of the heart*, combined with artificial respiration. The compression of the heart causes a slight movement of the blood, while it acts at the same time as a rhythmical cardiac stimulus. After recovery of the respiration, the reflex excitability is restored, and gradually also voluntary movements. The animals are blind for several days, the brain acts slowly, and the urine contains sugar. These experiments show how important it is in cases of asphyxia to act at the same time upon the heart.

For **physiological purposes**, artificial respiration is often made use of, especially after poisoning with curara. Air is *forced* into the lungs by means of an elastic bag or bellows, attached to a cannula tied in the trachea. The cannula has a small opening in the side of it to allow the expired air to escape.

Pathological.—After the lungs have once been properly distended with air, it is impossible by any amount of direct compression of them to get rid of all the air. This is probably due to the pressure acting on the small bronchi, so as to squeeze them, before the air can be forced out of the air-vesicles. If, however, a lung be filled with CO₂, and be suspended in water, the CO₂ is absorbed by the water, and the lungs become quite free from air and are *atelectic* (Hermann and Keller). The atelectasis, which sometimes occurs in the lung, may thus be explained:—If a bronchus is stopped with mucus or exudation, an accumulation of CO₂ in the air-vesicles belonging to this bronchus occurs. If this CO₂ is absorbed by the blood or lymph, the corresponding area of the lung will become atelectic. Sometimes there is spasm of the respiratory muscles, brought about by direct or reflex stimulation of the respiratory centre.

369. The Centre for the Inhibitory Nerves of the Heart—(Cardio-Inhibitory).

The fibres of the vagus which, when moderately stimulated, diminish the action of the heart, when strongly stimulated, however, arrest its action, and cause it to stand still in diastole (§ 352, 7), are supplied to the vagus through the spinal accessory nerve (§ 353), and have their centre in the medulla oblongata.

[Gaskell has shown that stimulation of the vagus not only influences the rhythm of the heart's action, but it modifies the other functions of the cardiac muscle. Stimulation of the vagus influences—(a) The

automatic rhythm, i.e., the rate at which the heart contracts automatically; (b) the *force* of the contractions, more especially the auricles, although in some animals, *e.g.*, the tortoise, the ventricles are not affected; (c) the *power of conduction, i.e.*, the capacity for conducting the muscular contractions. According to Gaskell, the vagus acts upon the rhythmical power of the muscular fibres of the heart.]

This centre may be excited *directly* in the medulla, and also *reflexly* by stimulating certain afferent nerves.

Many observers assume that this centre is in a state of *tonic excitement, i.e.*, that there is a continuous, uninterrupted, regulating, and inhibitory action of this centre upon the heart through the fibres of the vagus. According to Bernstein, this tonic excitement is caused reflexly through the abdominal and cervical sympathetic.

I. **Direct Stimulation of the Centre.**—This centre may be stimulated *directly* by the same stimuli that act upon the respiratory centre. 1. *Sudden anæmia* of the oblongata, by ligature of both carotids, both subclavians, or decapitating a rabbit, the vagi alone being left undivided, causes slowing, and even temporary arrest of the action of the heart. 2. *Sudden venous hyperæmia* acts in a similar manner, and it can be produced by ligaturing all the veins returning from the head (Landois, Hermann and Escher). 3. The *increased venosity* of the blood, produced either by direct cessation of the respirations (rabbit), or by forcing into the lungs a quantity of air containing much CO₂ (Traube). As the circulation in the placenta (the respiratory organ of the fœtus) is interfered with during severe labour, this sufficiently explains the constant enfeeblement of the action of the heart during protracted labour—it is due to stimulation of the central end of the vagus by the dyspnoic blood (B. S. Schultze). 4. At the moment the respiratory centre is excited, and an *inspiration* occurs, there is a variation in the inhibitory activity of the cardiac centre (Donders, Pfüger, Frédéricq—§ 74, a. 4). 5. The centre is excited by increased *blood-pressure* within the cerebral arteries.

II. The cardio-inhibitory centre may be excited **reflexly**—1. By stimulation of sensory nerves (Lovén, Kratschmer). 2. By stimulation of the central end of one vagus, provided the other vagus is intact (v. Bezold, Donders, Aubert, and Roever). 3. By stimulation of the sensory nerves of the intestines by tapping upon the belly (Goltz's *tapping experiment*), whereby the action of the heart is arrested. Stimulation of the splanchnic directly (Asp and Ludwig), or of the abdominal or cervical sympathetic (Bernstein) produces the same result. Very strong stimulation of sensory nerves, however, arrests the above-named reflex effects upon the vagus (§ 361, 3).

Tapping Experiment.—Goltz's experiment succeeds at once by tapping the intestines of a frog directly, say with the handle of a scalpel, especially if the

intestine has been exposed to the air for a short time, so as to become inflamed (Tarchanoff). Stimulation of the stomach of the dog causes slowing of the heart-beat (Sig. Mayer and Pribram).

[Mr. William finds that the action of the heart of the eel may be arrested reflexly with very great facility. The reflex inhibition is obtained by slight stimulation of the gills (through the branchial nerves), the skin of the head and tail and parietal peritoneum, and in fact, by severe injury of almost any part of the animal, except the abdominal organs.]

[Effect of Swallowing Fluids.—Kronecker has shown that the act of swallowing interferes with or abolishes temporarily the cardio-inhibitory action of the vagus, so that the pulse-rate is greatly accelerated. Merely sipping a wine-glass full of water may raise the rate thirty per cent. Hence, sipping cold water acts as a powerful cardiac stimulant.]

According to Hering, the excitability of the cardio-inhibitory centre is diminished by vigorous artificial ventilation of the lungs with atmospheric air. At the same time there is a considerable fall of the blood-pressure (§ 352, 8, 4).

In man, a vigorous expiration, owing to the increased intra-pulmonary pressure, causes an acceleration of the heart-beat, which Sommerbrodt ascribes to a diminution of the activity of the vagi. At the same time the activity of the vaso-motor centre is diminished (§ 60, 2).

Stimulation of the trunk of the vagus from the centre downwards, along its whole course, and also of certain of its cardiac branches [inferior cardiac], causes the heart either to beat more slowly or arrests its action in diastole. The result depends upon the strength of the stimulus employed, feeble stimuli slow the action of the heart, while strong stimuli arrest it in diastole. The frog's heart may be arrested by stimulating the fibres of the vagus upon the sinus venosus. If *strong* stimuli be applied, either to the centre or to the course of the nerve for a *long time*, the part stimulated becomes *fatigued*, and the heart beats more rapidly in spite of the continued stimulation. If a part of the nerve lying nearer the heart be stimulated, inhibition of the heart's action is brought about, as the stimulus acts upon a fresh portion of nerve.

The following points have also been ascertained regarding the stimulation of the inhibitory fibres:—

1. The experiments of Löwit on the frog's heart, confirmed by Heidenhain, showed that electrical and chemical stimulation of the vagus produces different results as regards the extent of the ventricular systole, as well as the number of heart-beats; the contractions either become smaller, or less frequent, or they become smaller and less frequent simultaneously. Strong stimuli cause, in addition, well marked relaxation of heart-muscle during diastole.

2. In order to cause inhibition of the heart, a *continuous* stimulus is not necessary.

3. Donders, with Prahl and Nüel, observed that arrest of the heart's action did not take place immediately the stimulus was applied to the vagus, but about $\frac{1}{6}$ th of a second—*period of latent stimulation*—elapsed before the effect was produced on the heart.

A *rhythmically interrupted* moderate stimulus suffices (v. Bezold); 18–20 stimuli per second are required for mammals, and 2–3 per second for cold-blooded animals. If the heart be arrested by stimulation of the vagus, it can still contract, if it be excited *directly*, e.g., by pricking it with a needle, when it executes a *single* contraction.

5. According to A. B. Meyer, inhibitory fibres are present only in the *right* vagus in the turtle. It is usually stated that the *right* vagus is more effective than the left in other animals (e.g., rabbit—Masoïn, Arloing and Tripier); but this is subject to many exceptions (Landois and Langendorff).

6. The vagus has been compressed by the finger in the neck of man (Czermak, Concato); but this experiment is accompanied by danger, and ought not to be undertaken. The electrotonic condition of the vagus is stated in § 335, III.

7. Schiff found that stimulation of the vagus of the frog caused acceleration of the heart-beat, when he displaced the blood of the heart with saline solution. If blood-serum be supplied to the heart, the vagus regains its inhibitory action.

8. Many soda salts in a proper concentration arrest the inhibitory action of the vagus, while potash salts restore the inhibitory function of the vagi suspended by the soda salts. If, however, the soda or potash salts act too long upon the heart, they produce a condition in which, after the inhibitory function of the vagi is abolished, it is not again restored. The heart's action in this condition is usually arrhythmical (Löwit).

9. If the intracardial pressure be greatly increased, so as to accelerate greatly the cardiac pulsations, the activity of the vagus is correspondingly diminished (J. M. Ludwig and Luchsinger).

Poisons.—*Muscarin* stimulates the terminations of the vagus in the heart, and causes the heart to stand still in diastole (Schmiedeberg and Koppe). If *atropin* be applied in solution to the heart this action is set aside, and the heart begins to beat again. *Digitalin* diminishes the number of heart-beats by stimulating the cardio-inhibitory centre (vagus) in the medulla. Large doses diminish the excitability of the vagus centre, and increase at the same time the accelerating cardiac ganglia, so that the heart-beats are thereby increased. In small doses, digitalin raises the blood-pressure by stimulating the vaso-motor centre and the elements of the vascular wall (Klug). *Nicotin* first excites the vagus, then rapidly paralyses it (Schmiedeberg). *Hydrocyanic acid* has the same effect (Preyer). *Atropin* (v. Bezold) and *curara* (large dose—Cl. Bernard and Kölliker) paralyse the vagi, and so does a very low temperature or high fever.

370. The Centre for the Accelerating Cardiac Nerves and the Accelerating Fibres.

Nervus Accelerans.—It is more than probable that a centre exists in the medulla oblongata, which sends *accelerating fibres* to the heart. These fibres pass from the medulla oblongata—but from which part thereof has not been exactly ascertained—through the spinal cord, and leave the cord through the rami communicantes of the lower cervical and upper six dorsal nerves (Stricker), to pass into the sympathetic nerve. Some of these fibres, issuing from the spinal cord, pass through the first thoracic sympathetic ganglion and the ring of Vieussens, to join the cardiac plexus (Figs. 349 and 350). [These fibres, issuing from the spinal cord, frequently accompany the nerve running

along the vertebral artery], and they constitute the *Nervus accelerans cordis*. If the vagi of an animal be divided, stimulation of the medulla oblongata, of the lower end of the divided cervical spinal cord, even the lower cervical ganglion, or of the upper dorsal ganglion of the sympathetic (*Gang. stellatum*), causes acceleration of the heart-beats in the dog and rabbit, without the blood-pressure undergoing any change (Cl. Bernard, v. Bezold, Cyon, Schmiedeburg).

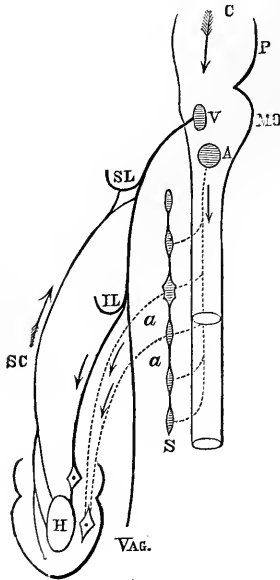

Fig. 349.

Scheme of the course of the accelerans fibres—P, pons; MO, medulla oblongata; C, spinal cord; V, inhibitory centre for heart; A, accelerans centre; VAG., vagus; SL, superior, IL, inferior laryngeal; SC, superior, IC, inferior cardiac; H, heart; C, cerebral impulse; S, cervical sympathetic; a, a, accelerans fibres.

On stimulating the medulla oblongata, or the cervical portion of the spinal cord, the *vaso-motor nerves* are, of course, simultaneously excited. The consequence is that the blood-vessels, supplied by vaso-motor nerves from the spot which is stimulated, contract, and the blood-pressure is greatly increased. Again, a simple increase of the blood-pressure accelerates the action of the heart; this experiment does not prove directly the existence of accelerating fibres lying in the upper part of the spinal cord. If, however, the splanchnic nerves be divided beforehand, and, as they supply the largest vaso-motor area in the body, the result of their division is to cause a great fall of the blood-pressure (p. 319), then on stimulating the above-named parts after this operation, the heart-beats are still increased in number, so that this increase cannot be due to the increased blood-pressure. Indirectly it may be shown, by dividing or extirpating all the nerves of the cardiac plexus, or at least all the nerves going to the heart, that stimulation of the medulla oblongata, or cervical part of the spinal cord, no longer causes an increased frequency of the heart's action to the same extent as before division of these nerves. The slightly increased frequency in this case is due to the increased blood-pressure.

[Fig. 350 shows the accelerator fibres passing through the ganglion stellatum of the cat to join the cardiac plexus.]

The accelerating centre is certainly not continually in a state of *tonic* excitement, as section of the accelerans nerves does not cause slowing of the action of the heart; the same is true of destruction of the medulla oblongata or of the cervical spinal cord. In the latter case the splanchnic nerves must be divided beforehand, to avoid the slowing effect on the action of the heart produced by the great fall of the blood-pressure consequent upon destruction of the cord, otherwise we

might be apt to ascribe the result to the action of the accelerating centre, when it is in reality due to the diminished blood-pressure (Brothers Cyon).

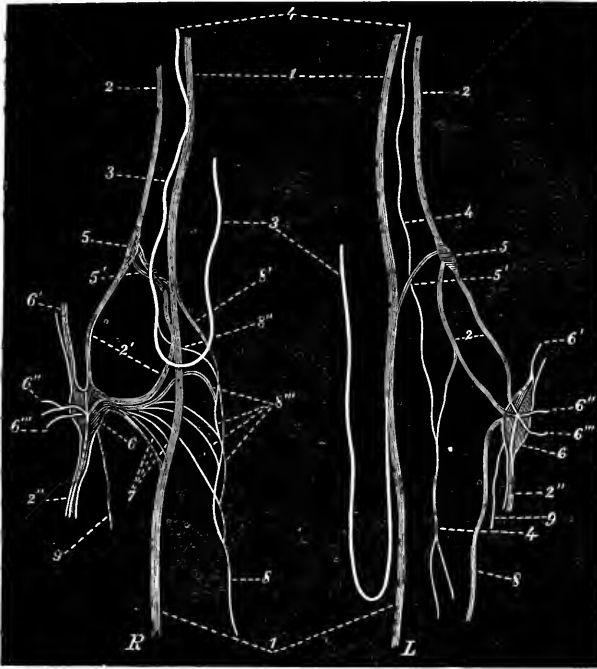

Fig. 350.

Cardiac plexus, and ganglion stellatum of the cat—R, right; L, left $\times 1\frac{1}{2}$; 1, vagus; 2', cervical sympathetic, and in the annulus of Vieussens; 2, communicating branches from the middle cervical ganglion and the ganglion stellatum; 2'', thoracic sympathetic; 3, recurrent laryngeal; 4, depressor nerve; 5, middle cervical ganglion; 5', communication between 5 and the vagus; 6, ganglion stellatum (1st thoracic ganglion); 7, communicating branches with the vagus; 8, nervus accelerans; 8, 8', 8'', roots of accelerans; 9, branch of the ganglion stellatum (Knott, after Böhm).

According to the results of the older observers (v. Bezold and others), some accelerating fibres run in the *cervical sympathetic*. A few fibres pass through the vagus to reach the heart (§ 352, 7—p. 818), and when they are stimulated, the heart-beat is accelerated and the cardiac contractions strengthened (Heidenhain and Löwit). The inhibitory fibres of the vagus lose their excitability more readily than the accelerating fibres, but the vagus fibres are more excitable than those of the accelerans.

Modifying Conditions.—When the peripheral end of the *nervus accelerans* is stimulated, a considerable time elapses before the effect upon the frequency of the

heart takes place—*i.e.*, it has a long latent period. Further, the acceleration thus produced disappears gradually. If the vagus and accelerans fibres be stimulated simultaneously, only the inhibitory action of the vagus is manifested. If, *while the accelerans* is being stimulated, the vagus be suddenly excited, there is a prompt diminution in the number of the heart-beats; and if the stimulation of the vagus is stopped, the accelerating effect of the accelerans is again rapidly manifested (C. Ludwig, with Schmiedeberg, Bowditch, Baxt). According to the experiments of Stricker and Wagner on dogs, with both vagi divided, a diminution of the number of the heart-beats occurred when both accelerantes were divided. This would indicate a tonic innervation of the latter nerves.

[Accelerans in the Frog.—Gaskell showed that stimulation of the vagus might produce two opposing effects; the one of the nature of inhibition, the other of augmentation. In the crocodile, the accelerans fibres leave the sympathetic chain at the large ganglion corresponding to the ganglion stellatum of the dog, and run along the vertebral artery up to the superior vena cava, and, after anastomosing with branches of the vagus, pass to the heart. “Stimulation of these fibres increases the *rate* of the cardiac rhythm, and augments the *force* of auricular contractions; while stimulation of the vagus slows the rhythm, and diminishes the strength of the auricular contractions.” The *strength* of the *ventricular* contraction, both in the tortoise and crocodile, does not seem to be influenced by stimulation of the vagus, and probably also it is unaffected by the sympathetic. The so-called vagus of the frog in reality consists of pure vagus fibres and sympathetic fibres, and is in fact a vago-sympathetic. Gaskell finds that *stimulation of the sympathetic*, before it joins the combined ganglion of the sympathetic and vagus, produces *purely augmentor*, or accelerating effects; while *stimulation of the vagus*, before it enters the ganglion, produces *purely inhibitory* effects. The two sets of fibres are quite distinct, so that in the frog, the sympathetic is a purely augmentor (accelerator), and the vagus a purely inhibitory nerve. Acceleration is merely one of the effects produced by stimulation of these nerves, so that Gaskell suggests that they ought to be called “augmentor,” or simply cardiac sympathetic nerves.]

371. Vaso-Motor Centre and Vaso-Motor Nerves.

Vaso-motor Centre.—The chief *general* or *dominating centre* which supplies all the non-striped muscles of the arterial system with *motor* nerves (vaso-motor, vaso-constrictor, vaso-hypertonic nerves) lies in the medulla oblongata, at a point which contains many ganglionic cells (Ludwig and Thiry). Those nerves which pass to the blood-vessels are known as *vaso-motor nerves*. The centre (which is 3 millimetres long, and $1\frac{1}{2}$ millimetres broad in the rabbit), reaches from the region of the

upper part of the floor of the medulla oblongata to within 4–5 mm. of the calamus scriptorius. Each half of the body has its own centre, placed $2\frac{1}{2}$ millimetres from the middle line on its own side, in that part of the medulla oblongata which represents the upward continuation of the lateral columns of the spinal cord; according to Ludwig and Owsjannikow, and Dittmar, in the lower part of the superior olives. *Stimulation* of this central area causes contraction of all the arteries, and in consequence there is great increase of the arterial blood-pressure, resulting in swelling of the veins and heart. *Paralysis* of this centre causes relaxation and dilatation of all the arteries, and consequently there is an enormous fall of the blood-pressure. Under ordinary circumstances, the vaso-motor centre is in a condition of *moderate tonic excitement* (§ 366). Just as in the case of the cardiac and respiratory centres, the vaso-motor centre may be excited directly and reflexly.

[**Position—How Ascertained.**—As stimulation of the *central* end of a sensory nerve, *e.g.*, the sciatic, in an animal under the influence of curara, causes a rise in the blood-pressure even after removal of the cerebrum, it is evident that the centre is not in the cerebrum itself. By making a series of sections from above downwards it is found, that this reflex effect is not affected until a short distance above the medulla oblongata is reached. If more and more of the medulla oblongata be removed from above downwards, then the reflex rise of the blood-pressure becomes less and less until, when the section is made 4–5 mm. above the calamus scriptorius, the effect ceases altogether. This is taken to be the lower limit of the *general* vaso-motor centre. The bilateral centre corresponds to some large multipolar nerve-cells, described by Clarke as the antero-lateral nucleus.]

I. Direct Stimulation of the Centre.—The *amount* and *quality* of the *gases* contained in the blood flowing through the medulla are of primary importance. In the condition of apnœa (§ 368, 1), the centre seems to be very slightly excited, as the blood-pressure undergoes a considerable decrease.

When the mixture of blood gases is such as exists under normal circumstances, the centre is in a state of moderate excitement, and running parallel with the respiratory movements are variations in the excitement of the centre (Traube-Hering curves—p. 174), these variations being indicated by the rise of the blood-pressure. When the blood is highly venous, produced either by asphyxia or by the inspiration of air containing a large amount of CO_2 , the centre is strongly excited, so that all the arteries of the body contract, while the venous system and the heart become distended with blood (Thiry). At the same time the velocity of the blood-stream is increased (Heidenhain). The same result is produced by sudden anæmia of the oblongata, by

ligature of both the carotid and subclavian arteries (Nawalichin, Sigm. Mayer), and, no doubt, also by the sudden stagnation of the blood in venous hyperæmia.

Action of Poisons.—*Strychnin* stimulates the centre directly, even in curarised dogs, and so do *nicotin* and *Calabar bean*.

Emptiness of the Arteries after Death.—The venosity of the blood, which occurs after death, always produces an energetic stimulation of the vaso-motor centre, in consequence of which the arteries are firmly contracted. The blood is thereby forced towards the capillaries and veins, and thus is explained the “emptiness of the arteries after death.”

Effect on Hæmorrhage.—Blood flows much more freely from large wounds when the vaso-motor centre is intact than if it be destroyed (frog). As psychical excitement undoubtedly influences the vaso-motor centre, we may thus explain the influence of psychical excitement (speaking, &c.), upon the cessation of hæmorrhage. If the hæmorrhage be severe, stimulation of the medulla oblongata, due to the anæmia, may ultimately cause constriction of the small arteries, and thus arrest the bleeding. Thus, surgeons are acquainted with the fact, that dangerous hæmorrhage is often arrested as soon as unconsciousness, due to cerebral anæmia, occurs. If the heart be ligatured in a frog, all the blood is ultimately forced into the veins, and this result is also due to the anæmic stimulation of the oblongata (Goltz). In *mammals*, when the heart is ligatured, the equilibration of the blood-pressure between the arterial and venous systems takes place more slowly when the medulla oblongata is destroyed than when it is intact (v. Bezold, Gscheidlen).

[Effect of Destruction of the Vaso-motor centre.—If two frogs be pithed and their hearts exposed, and both be suspended, then the hearts of both will be found to beat rhythmically and fill with blood. Destroy the medulla oblongata and spinal cord of one of them, then immediately in this case, the heart, although continuing to beat with an altered rhythm, ceases to be filled with blood, it appears collapsed, pale, and bloodless. There is a great accumulation of the blood in the abdominal organs and veins, and it is not returned to the heart so that the arteries are empty. This experiment of Goltz is held to show the existence of *venous tonus* depending on a cerebro-spinal centre. If a limb of this frog be amputated, there is little or no hæmorrhage, while in the other frog, the hæmorrhage is severe. The bearing of this experiment on conditions of “shock” is evident.]

Direct Electrical Stimulation.—On stimulating the centre directly in animals, it is found that single induction shocks only become effective when they succeed each other at the rate of 2 to 3 shocks per second. Thus there is a “**summation**” of the single shocks. The maximum contraction of the arteries, as expressed by the maximum blood-pressure is reached, when 10-12 *strong*, or 20-25 *moderately strong* shocks per second are applied (Kronecker and Nicolaides.)

Course of the Vaso-motor Nerves.—From the vaso-motor centre some fibres proceed directly through some of the cranial nerves to their area of distribution; through the trigeminus partly to the interior of the *eye* (§ 347, I., 2), through the lingual and hypoglossal to the *tongue* (§ 347, III., 4), through the vagus to a limited extent to the *lungs* (§ 352, 8, 2), and to the intestines (§ 352, 11).

All the other vaso-motor nerves descend in the lateral columns of the spinal cord (§ 364, 9); hence, stimulation of the lower cut end of the spinal cord causes contraction of the blood-vessels supplied by the nerves below the point of section (Pflüger). In their course through the cord, these fibres form connections with the *subordinate vaso-motor centres in the grey matter of the cord* (§ 362, 7), and then leave the cord either directly through the *anterior roots* of the spinal nerves to their areas of distribution, or they pass through the *rami communicantes* into

the sympathetic, and from it reach the blood-vessels to which they are distributed.

Cephalic Vaso-motors.—The following is the arrangement of these nerves in the region of the head:—The *cervical portion of the sympathetic* supplies the great majority of the blood-vessels of the head (see *Sympathetic*, § 356, A, 3—Cl. Bernard). In some animals, the *great auricular nerve* supplies a few vaso-motor fibres to its own area of distribution (Schiff, Lovèn, Moreau). The vaso-motor nerves to the **upper extremities** pass through the anterior roots of the middle dorsal nerves into the thoracic sympathetic, and upwards to the first thoracic ganglion, and from thence through the rami communicantes to the brachial plexus (Schiff, Cyon). The skin of the **trunk** receives its vaso-motor nerves through the dorsal and lumbar nerves. The vaso-motor nerves to the **lower extremities** pass through the nerves of the lumbar and sacral plexuses into the sympathetic, and from thence to the lower limbs (Pflüger, Schiff, Cl. Bernard). The **lungs**, in addition to a few fibres through the *vagus*, are supplied from the cervical spinal cord through the first thoracic ganglion (Brown-Séquad, Fick and Badoud, Lichtheim). The splanchnic is the greatest vaso-motor nerve in the body, and supplies the **abdominal viscera** (§ 356, B—v. Bezold, Ludwig and Cyon). The vaso-motor nerves of the **liver** (§ 173, 6), **kidney** (§ 276), and **spleen** (§ 103) have been referred to already. According to Stricker, most of the vaso-motor nerves leave the spinal cord between the fifth cervical and the first dorsal vertebrae.

As a general rule, the blood-vessels of the trunk and extremities are innervated from those nerves which give other fibres (*e.g.*, sensory) to those regions. The different vascular areas behave differently with regard to the intensity of the action of the vaso-motor nerves. The most powerful vaso-motor nerves are those that act upon the blood-vessels of peripheral parts, *e.g.*, the toes, fingers, and ears; while those that act upon central parts seem to be less active (Lewaschew), *e.g.*, on the pulmonic circulation (§ 88).

II. Reflex Stimulation of the Centre.—There are fibres contained in the different afferent nerves whose stimulation affects the vaso-motor centre. There are nerve-fibres whose stimulation *excites* the vaso-motor centre, thus causing a stronger contraction of the arteries, and consequently an increase of the arterial blood-pressure. These are called "*pressor*" fibres. Conversely, there are other fibres whose stimulation reflexly diminishes the excitability of the vaso-motor centre. These act as reflex inhibitory nerves on the centre, and are known as "*depressor*" nerves.

Pressor, or excito-vaso-motor nerves, have already been referred to in connection with the superior and inferior laryngeal nerves (§ 352, 12, *a*); in the trigeminus, which, when stimulated directly (p. 803) causes a pressor action, as well as when stimulating vapours are blown into the nostrils (Hering and Kratschmer). [The rise of the blood-pressure in this case, however, is accompanied by a change in the character of the heart's beat, and in the respirations. Rutherford has shown that in the rabbit the vapour of chloroform, ether, amylic nitrite, acetic acid or ammonia, held before the nose of a rabbit greatly retards or even arrests the heart's action, and the same is true if the nostrils be closed

by the hand. This arrest does not occur if the trachea be opened, and Rutherford regards the result as due not to the stimulation of the sensory fibres of the trigeminus, but to the *state of the blood* acting on the cardio-inhibitory nerve apparatus.] Hubert and Roever found pressor fibres in the cervical sympathetic; S. Mayer and Pribram found that mechanical stimulation of the stomach, especially of its serosa, caused pressor effects (§ 352, 12, c). According to Lovèn, the *first* effect of stimulating every sensory nerve is a pressor action.

[If a dog be poisoned with *curara*, and the *central* end of one sciatic nerve be stimulated, there is a great and steady rise of the blood-pressure, chiefly owing to the contraction of the abdominal blood-vessels, and at the same time there is no change in the heart-beat. If, however, the animal be poisoned with *chloral*, there is a fall of the blood-pressure resembling a depressor effect.]

O. Naumann found that *weak* electrical stimulation of the skin caused at first contraction of the blood-vessels, especially of the mesentery, lungs, and the web, with simultaneous excitement of the cardiac activity and acceleration of the circulation (frog). *Strong* stimuli, however, had an opposite effect, *i.e.*, a depressor effect, with simultaneous decrease of the cardiac activity. The application of *heat* and *cold* to the skin produces reflexly a change in the lumen of the blood-vessels and in the cardiac activity (Röhrig, Winternitz). Pinching the skin causes contraction of the vessels of the pia mater of the rabbit (Schüller), and the same result was produced by a warm bath, while cold dilated the vessels. These results are due partly to pressor and partly to depressor effects, but the chief cause of the dilatation of the blood-vessels is the increased blood-pressure due to the cold constricting the cutaneous vessels. Heat, of course, has the opposite effect.

Depressor fibres, *i.e.*, fibres whose stimulation diminishes the activity of the vaso-motor centre, are present in many nerves. They are specially numerous in the *superior cardiac* branch of the vagus, which is known as the *depressor nerve* (§ 352, 6).

The trunk of the vagus below the latter, also contains depressor fibres (v. Bezold and Dreschfeld), as well as the pulmonary fibres (dog—Taljanzeff). The latter also act as depressors during strong expiratory efforts (p. 149); while Hering found that inflating the lungs (to 50 mm. Hg. pressure) caused a fall of the blood-pressure (and also accelerated the heart-beats—§ 369, II.). Stimulation of the central end of sensory nerves, especially when it is intense and long-continued, causes dilatation of the blood-vessels in the area supplied by them (Lovèn).

According to Latschenberger and Deahna, all sensory nerves contain both pressor and depressor fibres.

[If a rabbit be poisoned with *curara*, and the *central* end of the *great auricular nerve* be stimulated, there is a double effect—one local and the other general; the blood-vessels throughout the body, but especially in the splanchnic area, contract, so that there is a general rise of the

blood-pressure, while the blood-vessels of the ear are dilated. If the central end of the *tibial nerve* be stimulated, there is a rise of the general blood-pressure, but a local dilatation of the saphena artery in the limb of that side (Lovèn). Again, the temperature of one hand and the condition of its blood-vessels influences that of the other. If one hand be dipped in cold water, the temperature of the other hand falls. Thus pressor and depressor effects may be obtained from the same nerve. The vaso-motor centre, therefore, primarily regulates the condition of the blood-vessels, but through them it obtains its importance by regulating and controlling the *blood-supply*, according to the needs of an organ.]

The central artery of a rabbit's ear contracts regularly and rhythmically, 3 to 5 times per minute. Schiff observed that stimulation of sensory nerves caused a dilatation of the artery, which was preceded by a slight temporary constriction.

Depressor effects are produced in the area of an artery to which direct pressure is applied, as occurs, for example, when the sphygmograph is applied for a long time—the pulse-curves become larger, and there are signs of diminished arterial tension (§ 75).

Rhythmical Contraction of Arteries.—In the intact body, slow alternating contraction and dilatation, without there being a uniform rhythm, have been observed in the arteries of the ear of the rabbit, the membrane of a bat's wing, and the web of a frog's foot. This arrangement, observed by Schiff, supplies more or less blood to the parts according to the action of external conditions. It has been called a "*periodic regulatory muscular movement*."

Perhaps the arteries are endowed with a second kind of movement, consisting in this, that every pulsatile dilatation of the arteries is accompanied by an active contraction, which would coincide with the descending limb of the sphygmogram. This kind of movement, however, has not been definitely proved to exist.

Direct local applications may influence the lumen of the blood-vessels; cold and moderate electrical stimuli cause contraction; while, conversely, heat and strong mechanical or electrical stimuli cause dilatation, although, with the latter two, there is usually a preliminary constriction.

Effect on Temperature.—The vaso-motor nerves influence the temperature, not only of individual parts, but of the whole body.

1. **Local Effects.**—Section of a peripheral vaso-motor nerve, *e.g.*, the *cervical sympathetic*, is followed by dilatation of the blood-vessels of the parts supplied by it, (such as the ear of the rabbit), the intra-arterial pressure dilating the paralysed walls of the vessels. Much arterial blood, therefore, pass into and causes a *congestion* and redness of the parts, or *hyperæmia*; while, at the same time, the *temperature* is increased. There is also increased transudation through the dilated

capillaries within the dilated areas; the velocity of the blood-stream is, of course, diminished, and the blood-pressure increased. The pulse is also felt more easily, because the blood-vessels are dilated. Owing to the increase of the blood-stream, the blood may flow from the veins almost arterial (bright red) in its characters, and the pulse may even be propagated into the veins, so that the blood spouts from them (Cl. Bernard). Stimulation of the peripheral end of a vaso-motor nerve causes the opposite results—pallor, owing to contraction of the vessels, diminished transudation, and fall of the temperature on the surface. The smaller arteries may contract so much that their lumen is almost obliterated. Continued stimulation ultimately exhausts the nerve, and causes, at the same time, the phenomena of paralysis of the vascular wall.

Secondary Results.—The immediate results of paralysis of the vaso-motor nerves lead to other effects; the paralysis of the muscles of the blood-vessels must lead to congestion of the blood in the part; the blood moves more slowly, so that the parts in contact with the air cool more easily, and hence the first stage of *increase* of the temperature may be followed by a *fall* of the temperature. The ear of a rabbit with the sympathetic divided, after several weeks, becomes cooler than the ear on the sound one. If in man, the motor muscular nerves, as well as the vaso-motor fibres, are paralysed, then the paralysed limb becomes cooler, because the paralysed muscles no longer contract to aid in the production of heat (§ 338), and also because the dilatation of the muscular arteries, which accompanies a muscular contraction, is absent. Should atrophy of the paralysed muscles set in, the blood-vessels also become smaller. Hence, paralysed limbs in man, generally become cooler as time goes on. The *primary* effect, however, in a limb, *e.g.*, after section of the sciatic, or lesion of the brachial plexus, is an increase of the temperature.

If, at the same time, the vaso-motor nerves of a large area of the skin be paralysed, *e.g.*, the lower half of the body after section of the spinal cord, then so much heat is given off from the dilated blood-vessels that, either the warming of the skin lasts for a very short time and to a slight degree, or there may be cooling at once. Some observers (Tschetschichin, Naunyn, Quincke, Heidenhain, Wood) observed a rise of the temperature after section of the cervical spinal cord, but Riegel did not observe this increase.

2. **Effect on the Temperature of the Whole Body.**—Stimulation or paralysis of the vaso-motor nerves of a *small* area has practically no effect on the general temperature of the body. If, however, the vaso-motor nerves of a *considerable area* of the skin be suddenly paralysed, then the temperature of the entire body falls, because more heat is given off from the dilated vessels than under normal circumstances. This occurs when the spinal cord is divided high up in the neck. The inhalation of a few drops of amyl nitrite, which dilates the blood-vessels of the skin, causes a fall of the temperature (Sassetzki and Manassein). Conversely, stimulation of the vaso-motor nerves of a large area increases

the temperature, because the constricted vessels give off less heat. The temperature in fever may be partly explained in this way (§ 220, 4).

The activity of the heart, *i.e.*, the number and energy of the cardiac contractions, is influenced by the condition of the vaso-motor nerves. When a large vaso-motor area is paralysed, the muscular blood-channels are dilated, so that the blood does not flow to the heart at the usual rate and in the usual amount, as the pressure is considerably diminished. Hence, the heart executes extremely small and slow contractions. Stricker even observed that, the heart of a dog ceased to beat on extirpating the spinal cord from the 1st cervical to the 8th dorsal vertebra. Conversely, we know that stimulation of a large vaso-motor area, by constricting the blood-vessels, raises the arterial blood-pressure considerably. As the arterial pressure affects the pressure within the left ventricle, it may act as a mechanical stimulus to the cardiac wall, and increase the cardiac contractions both in number and strength. Hence, the circulation is accelerated (Heidenhain, Slavjansky).

Splanchnic.—By far the largest vaso-motor area in the body is that controlled by the splanchnic nerves, as they supply the blood-vessels of the abdomen (p. 319); hence, stimulation of their peripheral ends is followed by a great rise of the blood-pressure. When they are divided, there is such a fall of the blood-pressure, that other parts of the body become more or less anæmic, and the animal may even die from “being bled into its own belly.” Animals whose portal vein is ligatured die for the same reason (C. Ludwig and Thiry) [see § 87].

The capacity of the vascular system, depending as it does in part upon the condition of the vaso-motor nerves, influences the *body-weight*. Stimulation of certain vascular areas may cause the rapid excretion of water, and we may thus account in part for the diminution of the body-weight, which has been sometimes observed after an epileptic attack terminating with polyuria.

Trophic disturbances sometimes occur after affections of the vaso-motor nerves (p. 782). Paralysis of the vaso-motor nerves not only causes dilatation of the blood-vessels and local increase of the blood-pressure, but it may also cause increased transudation through the capillaries [§ 203]. When the active contraction of the muscles is abolished at the same time, the blood-stream becomes slower; and, in some cases, the skin becomes livid, owing to the venous congestion. There is a diminution of the normal transpiration, and the epidermis may be dry and peel off in scales. The growth of the hair and nails may be affected by the congestion of blood, and other tissues may also suffer.

Vaso-motor Centres in the Spinal Cord.—Besides the dominating centre in the medulla oblongata, the blood-vessels are acted upon by *local or subordinate vaso-motor centres in the spinal cord*, as is proved by the following observations:—If the spinal cord of an animal be divided, then all the blood-vessels supplied by vaso-motor nerves below the point of section are paralysed, as the vaso-motor fibres proceed from the medulla oblongata. If the animal lives, the blood-vessels regain their tone and their former calibre, while the rhythmical movements of their muscular walls are ascribed to the subordinate centres in the lower part of the spinal cord (Lister, Goltz, Vulpian—§ 362, 7).

These subordinate centres may also be influenced *reflexly*; after destruction of the medulla oblongata, the arteries of the frog's web still contract reflexly when the sensory nerves of the hind leg are stimulated (Putnam, Nussbaum, Vulpian).

If now the lower divided part of the cord be *crushed*, the blood-vessels again dilate, owing to the destruction of the subordinate centres. In animals which survive this operation, the vessels of the paralysed parts gradually recover their normal diameter and rhythmical movements. This effect is ascribed to *ganglia*, which are supposed to exist along the course of the vessels. These ganglia [or peripheral nervous mechanisms] might be compared to the ganglia of the heart, and seem by themselves capable of sustaining the movements of the vascular wall. Even the blood-vessels of an excised kidney exhibit periodic variations of their calibre (C. Ludwig and Mosso). It is important to observe that the walls of the blood-vessels contract as soon as the blood becomes highly *venous*. Hence, the blood-vessels offer a greater resistance to the passage of venous than to arterial blood (C. Ludwig). Nevertheless, the blood-vessels, although they recover part of their tone and mobility, never do so *completely*.

The effects of direct mechanical, chemical, and electrical stimuli on blood-vessels may be due to their action on these peripheral nervous mechanisms. The arteries may contract so much as almost to disappear, but sometimes dilatation follows the primary stimulus.

Lewaschew found that limbs, in which the vaso-motor fibres had undergone degeneration, reacted like intact limbs to variations of temperature; heat relaxed the vessels, and cold constricted them. It is highly probable that the variations of the vascular lumen depend upon the stimulation of the peripheral nervous mechanisms. Amyl nitrite and digitalis act on the latter.

The *pulsating veins* in the bat's wing still continue to beat after section of all their nerves, which is in favour of the existence of local nervous mechanisms (Luchsinger, Schiff).

Influence of the Cerebrum.—The cerebrum influences the vaso-motor centre, as is proved by the sudden pallor that accompanies some psychological conditions, such as fright, or terror. There is a centre in the grey matter of the cerebrum where stimulation causes cooling of the opposite side of the body.

Although there is one general vaso-motor centre in the medulla oblongata, which influences *all* the blood-vessels of the body, it is really a *complex, composite* centre, consisting of a *number* of closely aggregated centres, each of which presides over a particular vascular area. We know something of the *hepatic* (§ 175) and *renal* centres (§ 276).

Many **poisons** *excite* the vaso-motor nerves, such as ergotin, tannic acid, copaiba, and cubebs; others *first excite*, and then *paralyse*, e.g., chloral hydrate, morphia, landanosin, veratrin, nicotin, Calabar bean, alcohol; others rapidly *paralyse* them, e.g., amyl nitrite, CO (§ 17), atropin, muscarin. The paralytic action

of the poison is proved by the fact that, after section of the vagi and accelerantes, neither the pressor nor the depressor nerves, when stimulated, produce any effect. Many pathological conditions affect the vaso-motor nerves.

The veins are also influenced by vaso-motor nerves (Goltz), and so are the *lymphatics*, but we know very little about this condition.

Pathological.—The *angio-neuroses*, or nervous affections of blood-vessels, form a most important group of diseases. The parts primarily affected may be either the peripheral nervous mechanisms, the subordinate centres in the cord, the dominating centre in the medulla, or the grey matter of the cerebrum. The effect may be direct or reflex. The dilatation of the vessels may also be due to stimulation of vaso-dilator nerves, and the physician must be careful to distinguish whether the result is due to paralysis of the vaso-constrictor nerves, or stimulation of the vaso-dilator fibres.

Angio-neuroses of the skin occur in affections of the vaso-motor nerves, either as a *diffuse* redness or pallor; or there may be *circumscribed* affections. Sometimes, owing to the stimulation of individual vaso-motor nerves, there are local cutaneous arterio-spasms (Nothnagel). In certain acute febrile attacks—after previous initial violent stimulation of the vaso-motor nerves, especially during the cold stage of fever—there may be different forms of paralytic phenomena of the cutaneous vessels. In some cases of epilepsy in man, Trousseau observed irregular, red, angio-paralytic patches (*tâches cérébrales*). Continued strong stimulation may lead to interruption of the circulation, which may result in gangrene of the skin (Weiss) and deeper-seated parts.

Hemicrania, due to unilateral spasm of the branches of the carotid on the head, is accompanied by severe headache (du Bois-Reymond). The cervical sympathetic nerve is intensely stimulated, a pale, collapsed, and cool side of the face, contraction of the temporal artery like a firm whip cord, dilatation of the pupil, secretion of thick saliva, are sure signs of this affection. This form may be followed by the opposite condition of paralysis of the cervical sympathetic, where the effects are reversed. Sometimes the two conditions may alternate.

Basedow's disease is a remarkable condition, in which the vaso-motor nerves are concerned; the heart beats very rapidly (90–120–200 beats per minute), causing palpitation; there is swelling of the thyroid gland (*struma*), and projection of the eyeballs (*exophthalmos*) with imperfectly co-ordinated movements of the upper eyelid, when the plane of vision is raised or lowered. Perhaps in this disease we have to deal with a simultaneous stimulation of the accelerans cordis (§ 370), the motor fibres of Müller's muscles of the orbit and eyelids (§ 347, I.), as well as of the vaso-dilators of the thyroid gland. The disease may be due to direct stimulation of the sympathetic channels or their spinal origins, or it may be referred to some reflex cause. It has also been explained, however, thus, that the exophthalmos and struma are the consequence of vaso-motor paralysis, which results in enlargement of the blood-vessels, while the increased cardiac action is a sign of the diminished or arrested inhibitory action of the vagus. All these phenomena may be caused, according to Filehne, by injury to the upper part of both restiform bodies in rabbits.

Visceral Angio-neuroses.—The occurrence of sudden hyperæmia with transudations and ecchymoses, in some thoracic or abdominal organs may have a neurotic basis. As already mentioned, injury to the pons, corpus striatum, and optic thalamus may give rise to hyperæmia, and ecchymoses in the lungs, pleuræ, intestines, and kidneys. According to Brown-Séquard, compression or section of one half of the pons causes ecchymoses, especially in the lung of the opposite side; he also observed ecchymoses in the renal capsule after injury of the lumbar portion of the spinal cord (§ 379).

The dependence of **diabetes mellitus** upon injury to the vaso-motor nerves is referred to in § 175; the action of the vaso-motor nerves on the **secretion of urine** in § 276; and **fever** in § 220.

372. Vaso-dilator Centre and Vaso-dilator Nerves.

Although a vaso-dilator *centre* has not been definitely proved to exist in the medulla, still its existence there has been surmised. Its action is opposite to that of the vaso-motor centre. The centre is certainly not in a continuous or tonic state of excitement. The vaso-dilator nerves behave in their function similarly to the cardiac branches of the vagus; both, when stimulated, cause relaxation and rest (Schiff, Cl. Bernard). [They are not paralysed, however, by a large dose of atropin.] Hence, these nerves have been called *vaso-inhibitory*, vaso-hypotonic, or vaso-dilator nerves.

[The existence of vaso-dilator nerves is assumed in accordance with such facts as the following:—If the *chorda tympani* be divided, there is no change in the blood-vessels of the sub-maxillary gland, but if its *peripheral* end be stimulated, in addition to other results (§ 145), there is dilatation of the blood-vessels of the sub-maxillary glands, so that its veins discharge bright florid blood, while they spout like an artery. Similarly, if the *nervi erigentes* be divided there is no effect on the blood-vessels of the penis (§ 362, 4), but if their *peripheral* ends be stimulated with faradic electricity, the sinuses of the corpora cavernosa dilate, become filled with blood, and erection takes place (§ 436). Other examples in muscle and elsewhere are referred to below.]

Dyspnoeic blood stimulates this centre as well as the vaso-motor centre, so that the cutaneous vessels are dilated, while simultaneously the vessels of the internal organs are contracted and the organs anæmic, owing to the stimulation of their vaso-motor centre (Dastre and Morat).

Course of the Vaso-dilator Nerves.—To some organs they pass as special nerves—to other parts of the body, however, they proceed along with the vaso-motor and other nerves. According to Dastre and Morat, the vaso-dilator nerves for the *bucco-labial region* (dog), pass out from the cord by the 1st to the 5th dorsal nerves, and go through the rami communicantes into the sympathetic, then to the superior cervical ganglion, and lastly through the carotid and inter-carotid plexus into the trigeminus. The maxillary branch of the trigeminus, however, also contains vaso-dilator fibres proper to itself (Laffont). In the grey matter of the cord, there is a special subordinate centre for the vaso-dilator fibres of the bucco-labial region. This centre may be acted on reflexly by stimulation of the vagus, especially its pulmonary branches, and even by stimulating the sciatic nerve. The *ear* receives its nerves from the 1st dorsal and lowest cervical ganglion, the *upper limb* from the thoracic portion, and the *lower limb* from the abdominal portion of the sympathetic. The vaso-dilator fibres run to the sub-maxillary and sub-lingual glands in the *chorda tympani* (§ 349, 4), while those for the posterior part of the tongue run in the glosso-pharyngeal nerve (§ 351, 4—Vulpian). Perhaps

the vagus contains those for the kidneys (§ 276). *Stimulation of the nervi erigentes* proceeding from the sacral plexus, causes dilatation of the arteries of the penis, together with congestion of the corpora cavernosa (§ 436, Eckhard, Lovén). Eckhard found that, erection of the penis can be produced by stimulation of the spinal cord, and of the pons as far as the peduncles, which may explain the phenomenon of priapism in connection with pathological irritations in these regions.

The **muscles** receive their vaso-dilator fibres for their vessels through the trunks of the motor nerves. *Stimulation of a motor nerve* or the spinal cord causes not only contraction of the corresponding muscles, but also dilatation of their blood-vessels (§ 294, II.—C. Ludwig and Sczelkow, Hafiz, Gaskell, Heidenhain)—the dilatation of the vessels taking place even when the muscle is prevented from shortening. [Gaskell observed under the microscope, the dilatation produced by stimulation of the nerve to the mylohyoid muscle of the frog.] Goltz showed that in the nerves to the limbs, *e.g.*, in the sciatic nerve, the vaso-motor and vaso-dilator fibres occur in the same nerve. If the peripheral end of this nerve be stimulated immediately after it is divided, the action of the vaso-constrictor fibres overcomes that of the dilators. If the peripheral end be stimulated several days after the section, when the vaso-constrictors have lost their excitability, the blood-vessels dilate under the action of the vaso-dilator fibres. Stimuli, which are applied at long intervals to the nerve, act especially on the vaso-dilator fibres; while tetanising stimuli act on the vaso-motors. The sciatic nerve receives both kinds of fibres from the sympathetic. It is assumed that the peripheral nervous mechanisms in connection with the blood-vessels are influenced by both kinds of vascular nerves; the vaso-motors (constrictors) increase, while the vaso-dilators diminish, the activity of these mechanisms or ganglia. *Psychical* conditions act upon the vaso-dilator nerves—the blush of shame, which is not confined to the face, but may even extend over the whole skin—is probably due to stimulation of the vaso-dilator centre.

Influence on Temperature.—The vaso-dilator nerves obviously have a considerable influence on the *temperature* of the body, and on the heat of the individual parts of the body. Both vascular centres must act as important regulatory mechanisms for the radiation of heat through the cutaneous vessels (§ 214, II). Probably they are kept in activity reflexly by sensory nerves. Disturbances in their function may lead to an abnormal accumulation of heat, as in fever (§ 220), or to abnormal cooling (§ 213, 7). Some observers, however, assume the existence of an intracranial "*heat-regulating centre*" (Tschetschichin, Naunyn, Quincke), whose situation is unknown. According to Wood, separation of the medulla oblongata from the pons causes an increased radiation and a diminished production of heat, due to the cutting off of the influences from the heat-regulating centre.

373. The Spasm Centre—The Sweat Centre.

Spasm Centre.—In the medulla oblongata, just where it joins the pons, there is a centre, whose stimulation causes *general spasms*. The centre may be excited by suddenly producing a highly venous condition of the blood ("*asphyxia spasms*," in cases of drowning), by sudden anæmia of the medulla oblongata, either in consequence of hæmorrhage, or ligature of both carotids and subclavians (Kussmaul and Tenner), and lastly by sudden venous stagnation caused by compressing the veins coming from the head. In all these cases, the

stimulation of the centre is due to the sudden interruption of the normal exchange of the gases. When these factors act quite gradually, death may take place without convulsions. Intense direct stimulation of the medulla, as by its sudden destruction, causes general convulsions.

Position.—Nothnagel attempted by direct stimulation to map out its position in rabbits; it extends from the area above the *ala cinerea* upwards to the *corpora quadrigemina*. It is limited externally by the *locus cœruleus* and the *tuberculum acusticum*. In the frog, it lies in the lower half of the fourth ventricle (Heubel). The centre is affected in extensive reflex spasms (§ 364, 6), *e.g.*, in poisoning with strychnin and in hydrophobia.

Poisons.—Many inorganic and organic poisons, most cardiac poisons, nicotin, picrotoxin, ammonia (§ 277), and the compounds of barium, cause death after producing convulsions, by acting on the spasm centre (Röber, Heubel, Böhm).

If the arteries going to the brain be ligatured, so as to paralyse the *oblongata*, then, on ligaturing the abdominal aorta, spasms of the lower limbs occur, owing to the anæmic stimulation of the motor ganglia of the spinal cord (Sigm. Mayer).

Pathological—Epilepsy.—Schröder van der Kolk found the blood-vessels of the *oblongata* dilated and increased in cases of epilepsy. Brown-Séquard observed that injury to the central or peripheral nervous system (spinal cord, *oblongata*, peduncle, *corpora quadrigemina*, sciatic nerve) of guinea-pigs produced epilepsy, and this condition even became *hereditary*. Stimulation of the cheek or of the face "*epileptic zone*," on the same side as the injury (spinal cord), caused at once an attack of epilepsy; but when the peduncle was injured, the opposite side must be stimulated. Westphal made guinea-pigs epileptic by repeated light blows on the skull, and this condition also became hereditary. In these cases, there was effusion of blood in the *medulla oblongata* and upper part of the spinal cord (§ 375 and § 378, D).

Direct stimulation of the cerebrum also produces epileptic convulsions. Strong electrical stimulation of the motor areas of the cortex cerebri is often followed by an epileptic attack (§ 375). [It is no unfrequent occurrence that, while we are stimulating the motor areas of the cortex cerebri of a dog, to find the animal exhibiting symptoms of local or general epilepsy.]

Sweat Centre.—A *dominating* centre for the secretion of the sweat of the entire surface of the body (§ 289, II)—with subordinate spinal centres (§ 362, 8)—occurs in the *medulla oblongata* (Adamkiewicz, Marmé, Nawrocki). It is double, and in rare cases the excitability is unequal on the two sides, as is manifested by unilateral perspiration (§ 289, 2).

Poisons.—Calabar bean, nicotin, picrotoxin, camphor, ammonium acetate, cause a secretion of sweat by acting directly on the sweat centre. Muscarin causes local stimulation of the peripheral sweat fibres—it causes sweating of the hind limbs after section of the sciatic nerves. Atropin arrests the action of muscarin (Oit, Wood Field, Nawrocki).

[Regeneration of the Spinal Cord.—In some animals true nervous matter is reproduced after part of the spinal cord has been destroyed, at least, this is so in tritons and lizards (H. Müller). As is well known in these animals, when the tail is removed it is reproduced, and Müller found that a part of the spinal cord corresponding to the new part of the tail is reproduced. Morphologically the elements were the same, but the spinal nerves were not reproduced, while physiologically, the new nerve substance was not functionally active; it corre-

sponds, as it were, to a lower stage of development. According to Masius and Vanlair, an excised portion of the spinal cord of a frog is reproduced after 6 months; while Brown-Séquard maintains that re-union of the divided surfaces of the cord takes place in pigeons after 6-15 months. A partial re-union is asserted to occur in dogs by Dentan, Naunyn, and Eichhorst, although Schieferdecker obtained only negative results, the divided ends being united only by connective-tissue (Schwalbe).]

374. Psychological Functions of the Brain.

The hemispheres of the cerebrum are usually said to be the *seat of all the psychical activities*. Only when they are intact are the processes of thinking, feeling, and willing possible. After they are destroyed, the organism comes to be like a complicated machine, and its whole activity is only the expression of the external and internal stimuli which act upon it. The psychical activities appear to be located in both hemispheres, so that after destruction of a considerable part of one of them, the other seems to act in place of the part destroyed. [Objection has been taken to the term, the "seat of" the will and intelligence, and undoubtedly it is more consistent with what we know, or rather do not know, to say that the existence of volition and intelligence is dependent on the connection of the cerebral cortex with the rest of the brain.]

Observations on Man.—Cases in which considerable *unilateral* lesions or destruction of one hemisphere have taken place without the psychical activities *appearing* to suffer sometimes occur. The following is a case communicated by Longet:—A boy, 16 years of age, had his parietal bone fractured by a stone falling on it, so that part of the protruding brain matter had to be removed. On reapplying the bandages more brain matter had to be removed. After 18 days he fell out of bed, and more brain matter protruded, which was removed. On the 35th day he got intoxicated, tore off the bandages, and with them a part of the brain matter. After his recovery the boy still retained his intelligence, but he was hemiplegic. Even when *both* hemispheres are *moderately* destroyed, the intelligence *appears* to be intact; thus, Trousseau describes the case of an officer whose fore-brain was pierced transversely by a bullet. There was *scarcely* any appearance of his mental or bodily faculties being affected. In other cases, destruction of parts of the brain peculiarly alters the character. We must be extremely careful, however, in forming conclusions in all such cases.

[In the celebrated "**American crow-bar case**" recorded by Bigelow, a young man was hit by a bar of iron which traversed the anterior part of the left hemisphere, going clean out at the top of his head. This man lived for thirteen years without any special mental manifestations. There were, however, some changes which might be referable to injury to the frontal region. In all cases it is most important to know both the exact *site* and the *extent* of the lesion.]

Imperfect Development of the Cerebrum.—Microcephalia, and hydrocephalus yield every result between diminution of the psychical activities and idiocy. Extensive inflammation, degeneration, pressure, anæmia of the blood-vessels, and the actions of many poisons produce the same effect.

Flourens' Doctrine.—Flourens assumed that, the *whole* of the cerebrum is

concerned in *every* psychical process. From his experiments on pigeons, he concluded that, if a small part of the hemispheres remained intact, it was sufficient for the manifestation of the mental functions; just in proportion as the grey matter of the hemispheres is removed, *all* the functions of the cerebrum are enfeebled, and when all the grey matter is removed, all the functions are abolished. According to this view, neither the different faculties nor the different perceptions are localised in special areas. Goltz holds a somewhat similar view to that of Flourens. He assumes that if an uninjured part of the cerebrum remain, it can to a certain extent perform the functions of the parts that have been removed. This Vulpian has called the "law of functional substitution" (*loi de suppléance*).

The **phrenological doctrine** of Gall († 1828) and Spurzheim assumes that the different mental faculties are located in different parts of the brain, and it is assumed that a large development of a particular organ may be detected by examining the external configuration of the head (*Cranioscopy*).

Extirpation of the Cerebrum.—After the removal of both cerebral hemispheres in animals, every voluntary movement, and every conscious impression, and sensory perception entirely ceases. On the other hand, the whole mechanical movements, and the maintenance of the equilibrium of the movements are retained. The **maintenance of the equilibrium** depends upon the mid-brain, and is regulated by important reflex channels (§ 379). The mid-brain (*corpora quadrigemina*) is connected not only with the grey matter of the spinal cord and medulla oblongata, the seat of extensive reflex mechanisms (§ 367), but it also receives fibres coming from the higher organs of sense, which also excite movements reflexly. The *corpora quadrigemina* are also supposed to contain a reflex inhibitory apparatus (§ 361, 2). The joint action of all these parts makes the *corpora quadrigemina* one of the most important organs for the harmonious execution of movements, and this even in a higher degree than the medulla oblongata itself (Goltz). Animals with their *corpora quadrigemina* intact retain the equilibrium of their bodies under the most varied conditions, but they lose this power as soon as the mid-brain is destroyed (Goltz). Christiani locates the co-ordinating centre for the change of place and the maintenance of the equilibrium, in mammals in front of the inspiratory centre in the 3rd ventricle (p. 878).

That impressions from the skin and sense organs are concerned in the maintenance of the equilibrium is proved by the following facts:—A frog without its cerebrum at once loses its power of balancing itself as soon as the skin is removed from its hind-limbs. The action of impressions communicated through the eyes is proved by the difficulty or impossibility of maintaining the equilibrium in nystagmus (§ 350), and by the vertigo which often accompanies paralysis of the external ocular muscles. In persons whose cutaneous sensibility is diminished, the eyes are the chief organs for the maintenance of the equilibrium, they fall over when the eyes are closed. [This is well illustrated in cases of locomotor ataxia (p. 858).]

Frog.—A frog with its cerebrum removed retains its power of maintaining its equilibrium. It can sit, spring, or execute complicated,

co-ordinated movements, when appropriate stimuli are applied; when placed on its back, it immediately turns into its normal position on its belly; if stimulated it gives one or two springs and then comes to rest; when thrown into water, it swims to the margin of the vessel, and it may crawl up the side, and sit passive upon the edge of the vessel. When *incited* to move, it exhibits the most complete harmony and unity in all its movements. It sits on the same place continually as if in sleep, it takes no food, it has no feelings of hunger and thirst, it shows no symptoms of fear, and ultimately, if left alone, it becomes desiccated like a mummy on the spot where it sits. [If the flanks of such a frog be stroked, it croaks with the utmost regularity according to the number of times it is stroked. It seems to be influenced by light; for, if an object be placed in front of it so as to throw a strong shadow,

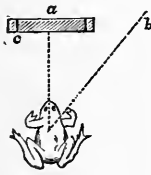

Fig. 351.

Frog without its cerebrum avoiding an object placed in its path (Goltz).

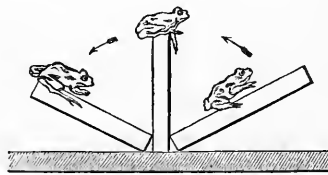

Fig. 352.

Frog without its cerebrum moving on an inclined board (Goltz).

then on stimulating the frog it will spring not against the object, *a*, but in the direction, *b* (Fig. 351). Its *balancing* movements on a board are quite remarkable and acrobatic in character. If it be placed on a board, and the board gently inclined (Fig. 352), it does not fall off as a frog merely with its spinal cord will do, but as the board is inclined so as to alter the animal's centre of gravity, it slowly crawls up the board until its equilibrium is restored. If the board be sloped as in Fig. 352, it will crawl up until it sits on the edge, and if the board be still further tilted, the frog will move as indicated in the figure. It only does so, however, when the board is inclined, and it rests as soon as its centre of gravity is restored. It responds to every stimulus just like a complex machine, answering each stimulus with an appropriate action.]

A pigeon without its cerebral hemispheres, behaves in a similar manner. When undisturbed it sits continuously, as if in *sleep*, but when stimulated it shows complete harmony of all its movements; it can walk, fly, perch, and balance its body. The sensory nerves and those of special sensation conduct impulses to the brain, they only discharge

reflex movements, but they do not excite conscious impressions. Hence, the bird starts when a pistol is fired close to its ear; it closes its eyes when it is brought near a flame, and the pupils contract; it turns away its head when the vapour of ammonia is applied to its nostrils. All these impressions are not perceived as conscious perceptions. The perceptive faculties—the will and memory—are abolished; the animal never takes food or drinks spontaneously. But if food be placed at the back part of its throat it is swallowed [reflex act], and in this way the animal may be maintained alive for months (Flourens, Longet, Goltz, and others).

Mammals (rabbit), owing to the great loss of blood consequent on removal of the cerebrum, are not well suited for experiments of this kind. Immediately after the operation, they show great signs of muscular weakness. When they recover they present the same general phenomena; only when they are stimulated, they run as if they were, blindfold against an obstacle. Vulpian observed a peculiar shriek or cry, which such a rabbit makes under the circumstances. Sometimes, even in man, a peculiar cry is emitted in some cases of pressure or inflammation, rendering the cerebral hemispheres inactive.

Observations on *somnambulists* show that in man also, complete harmony of all movements may be retained, without the assistance of the will or conscious impressions and perceptions. As a matter of fact, many of our ordinary movements are accomplished without our being conscious of them. They take place under the guidance of the basal ganglia.

The degree of intelligence in the animal kingdom is in relation to the size of the cerebral hemispheres, in proportion to the mass of the other parts of the central nervous system. Taking the brain alone into consideration, we observe that those animals have the highest intelligence in which the cerebral hemispheres greatly exceed the mid brain in weight. The mid brain is represented by the optic lobes in the lower vertebrates, and by the corpora quadrigemina in the higher vertebrates. In Fig. 357, VI represents the brain of a carp; V, frog; and IV, pigeon. In all these cases 1 indicates the cerebral hemispheres; 2, the optic lobes; 3, the cerebellum; and 4, the medulla oblongata. In the carp, the cerebral hemispheres are smaller than the optic lobes, in the frog, they exceed the latter in size. In the pigeon the cerebrum begins to project backward over the cerebellum. The degree of intelligence increases in these animals in this proportion. In the dog's brain (Fig. 357, II), the hemispheres completely cover the corpora quadrigemina, but the cerebellum still lies behind the cerebrum. In man the occipital lobes of the cerebrum completely overlap the cerebellum (Fig. 353).

Meynert's Theory.—According to Meynert, we may represent this relation in another way. As is known, fibres proceed downwards from the cerebral hemispheres through the crista or basis of the cerebral peduncle. These fibres are separated from the upper fibres or tegmentum of the peduncle by the locus niger, the tegmentum being connected with the corpora quadrigemina and the optic thalamus. The larger, therefore, the cerebral hemispheres the more numerous will be the fibres proceeding from it. In Fig. 357, II, is a transverse

section of the posterior corpora quadrigemina, with the aqueduct of Sylvius, and both cerebral peduncles of an adult man; *p, p* is the crista of each peduncle, and above it lies the locus niger (*s*). Fig. 357, IV, shows the same parts in a monkey; III, in a dog; and V, in a guinea-pig. The crista diminishes in the above series. There is a corresponding diminution of the cerebral hemispheres, and at the same time in the intelligence of the corresponding animals.

Sulci and Gyri.—The degree of intelligence also depends upon the number and depth of the convolutions. In the lowest vertebrates (fish, frog, bird) the furrows or sulci are absent (Fig. 357, IV, V, VI); in the rabbit there are two shallow furrows on each side (III). The dog has a complexly furrowed cerebrum (I, II). Most remarkable is the complexity of the sulci and convolutions of the cerebrum of the elephant, one of the most intelligent of animals. Nevertheless, some very stupid animals, as the ox, have very complex convolutions.

The **absolute weight** of the brain cannot be taken as guide to the intelligence. The elephant has *absolutely* the heaviest brain, but man has *relatively* the heaviest brain.

[We ought also to take into account the complexity of the convolutions and the depth of the grey matter, its vascularity, and the amount of anastomoses between its nerve cells.]

Time an Element in all Psychological Processes.—Every psychical process requires a certain time for its occurrence—a certain time always elapses between the application of the stimulus and the conscious reaction.

Reaction Time.—This time is known as "*reaction time*," and is distinctly longer than the simple reflex time required for a reflex act. It can be measured by causing the person experimented on to indicate by means of an electrical signal the moment when the stimulus is applied.

The reaction time consists of the following events:—(1) The *duration of perception*, *i.e.*, when we become conscious of the impression; (2) the duration of the time required to direct the *attention* to the impression; and (3) the duration of the voluntary impulse, together with (4) the time required for conducting the impulse in the afferent nerves to the centre, and (5) the time for the impulse to travel outwards in the motor nerves. If the signal be made with the hand, then the reaction time for the impression of *sound* is 0·136 to 0·167 second; for taste, 0·15 to 0·23; touch, 0·133 to 0·201 second (Horsch, v. Vintschgau and Höingschmied, Auerbach, Exner, and others); for olfactory impressions, which, of course, depend upon many conditions, (the phase of respiration, current of air), 0·2 to 0·5 second. Intense stimulation, increased attention, practice, expectation, and knowledge of the kind of stimulus to be applied, all diminish the time. Tactile impressions are most rapidly perceived when they are applied to the most sensitive parts (v. Vintschgau). The time is increased with very strong stimuli, and when objects difficult to be distinguished are applied (v. Helmholtz and Baxt). The time required to direct the *attention* to a number consisting of 1 to 3 figures, Tigerstedt and Bergquist found to be 0·015 to 0·035 second. Alcohol and the anaesthetics alter the time; according to their degree of action they shorten or lengthen it (Kräplin). In order that two shocks applied after each other be distinguished as two distinct impressions, a certain interval must elapse between the two shocks, for the ear 0·002 to 0·0075 second; for the eye, 0·044 to 0·047 second; for the finger, 0·277 second.

[The following table, after M'Kendrick, represents the general results obtained:—

Nature of Stimulus.	Time between application of stimulus and signal of perception in fractions of a second.	Name of Observer.
Shock on Left Hand,	·12	Exner.
Shock on Forehead,	·13	Do.
Shock on Toe of Left Foot,	·17	Do.
Sudden Noise,	·13	Do.
Visual impression of Electric Spark,	·15	Do.
Hearing a Sound,	·16	Donders.
Current to Tongue Causing Taste,	·16	} v. Vintschgau and Hönigschmied.
Saline Tastes,	·15	
Taste of Sugar,	·16	Do.
„ Acids,	·16	Do.
„ Quinine,	·23	Do.

In **sleep** and **waking**, we observe the periodicity of the active and passive conditions of the brain. During sleep, there is diminished excitability of the whole nervous system, which is only partly due to the fatigue of afferent nerves, but is largely due to the condition of the central nervous system. During sleep, we require to apply strong stimuli to produce reflex acts. In the deepest sleep, the psychical or mental processes seem to be completely in abeyance, so that a person asleep might be compared to an animal with its cerebral hemispheres removed. Towards the approach of the period when a person awakens, psychical activity may manifest itself in the form of **dreams**, which differ, however, from normal mental processes. They consist either of impressions, where there is no objective cause (hallucinations), or of voluntary impulses which are not executed, or trains of thought, where the reasoning and judging powers are disturbed. Often, especially near the time of waking, the actual stimuli may so act as to give rise to impressions which become mixed with the thoughts of a dream. The diminished activity of the heart (§ 70, 3, c), the respiration (§ 127, 4), the gastric and intestinal movements (§ 213, 4,), the formation of heat (§ 216, 4), and the secretions point to a diminished excitability of the corresponding nerve-centres, and the diminished reflex excitability to a corresponding condition of the spinal cord. The pupils are narrow during sleep, the deeper the latter is, so that in the deepest sleep they do not become contracted on the application of light. The pupils dilate when sensory or auditory stimuli are applied, and that the more the lighter the sleep; they are widest at the moment of awaking (Plotke). During sleep, there seems to be a condition of increased action of certain sphincter muscles—those for contracting the pupil and closing the eyelids (Rosenbach). The soundness of the sleep may be determined by the intensity of the sound required to waken a person. Kohlschütter found that at first sleep deepens very quickly, then more slowly, and the maximum is reached after one hour (according to Mönninghoff and Priesbergen after $1\frac{3}{4}$ hours); it then rapidly lightens, until several hours before waking it is very light. External or internal stimuli may suddenly diminish the depth of the sleep, but this may be followed again by deep sleep. The deeper the sleep, the longer it lasts.

The **cause** of sleep is the using up of the potential energy, especially in the central nervous system, which renders a restitution of energy necessary. Perhaps the accumulation of the decomposition products of the nervous activity may

also act (? lactates—Preyer), as producers of sleep. Sleep cannot be kept up for above a certain time, nor can it be interrupted voluntarily. Many narcotics rapidly produce sleep.

Hypnotism, or Animal Magnetism.—[Most important observations on this subject were made by Braid of Manchester, and many of the recent re-discoveries of Weinholt, Heidenhain, and others confirm Braid's results.] Heidenhain assumes that the cause of this condition is due to an inhibition of the ganglionic cells of the cerebrum, produced by continuous feeble stimulation of the face (slight stroking the skin or electrical applications), or of the optic nerve (as by gazing steadily at a small brilliant object), or of the auditory nerve (by uniform sounds); while sudden and strong stimulation of the same nerves, especially blowing upon the face, abolishes the condition. Berger [and so did Carpenter and Braid long ago] attributes great importance to the psychological factor, whereby the attention was directed to a particular part of the body. The facility with which different persons become hypnotic varies very greatly. When the hypnotic condition has been produced a number of times, its subsequent occurrence is facilitated, *e.g.*, by merely pressing upon the brow, by placing the body passively in a certain position, or by stroking the skin. In some people the mere idea of the condition suffices. A hypnotised person is no longer able to open his eyelids when they are pressed together. This is followed by spasm of the apparatus for accommodation in the eye, the range of accommodation is diminished, and there may be deviation of the position of the eyeballs; then follow phenomena of stimulation of the sympathetic in the oblongata; dilatation of the fissure of the eyelids and the pupil, exophthalmos, and increase of the respiration and pulse. At a certain stage there may be a great increase in the fineness of the functions of the sense-organs, and also of the muscular sensibility. Afterwards there may be analgesia of the part stroked, and loss of taste; the sense of temperature is lost less readily, and still later, that of sight, smell, and hearing. Owing to the abolition or suspension of consciousness, stimuli applied to the sense-organs do not produce conscious impressions or perceptions. But stimuli applied to the sense-organs of a hypnotised person cause movements, which, however, are unconscious, although they simulate voluntary acts. In persons with greatly increased reflex excitability, voluntary movements may excite reflex spasms; the person may be unable to co-ordinate his organs for speech.

Types.—According to Grützner, there are several forms of hypnotism—1, *Passive sleep*, where words are still understood, which occurs especially in girls; 2, owing to the increased reflex excitability of the striped muscles, certain *groups of muscles* may be contracted—a condition which may last for days, especially in strong people; at the same time ataxia may occur, and the muscles may fail to perform their functions (*artificial katalapsy*). During the stage of lethargy in hysterical persons, the tendon reflexes are often absent (Charcot and Richer); 3, *autonomy at call, i.e.*, the hypnotised person—in most cases the consciousness is still retained—obeys a command, in his condition, of light sleep. When the hand is grasped or the head stroked, he executes involuntary movements—runs about, dances, rides on a stool, and the like; 4, *hallucinations* occur only in some individuals when they waken from a deep sleep, the hallucinations (usually consisting of the sensation of sparks of fire or odours), being very strong and well pronounced; 5, imitation is rare, ordinary movements, such as walking, are easily imitated, the finer movements occur rarely. The “*echo speech*” is produced by pressure upon the neck, speaking into the throat, or against the abdomen. Pressure over the right eyebrow often ushers in the speech. Colour-sensation is suspended by placing the warm hand on the eye, or by stroking the opposite side of the head (Cohn). Stroking the limbs in the reverse direction gradually removes the rigidity of the limbs and causes the person to waken. Blowing on a part does so at once. Insane persons can be hypnotised. Disagreeable results follow only when the condition is induced too often and too continuously.

Hypnotism in Animals.—A hen remains in a rigid position when an object is suddenly placed before its eyes, or when a straw is placed over its beak, or when the head of the animal is pressed on the ground and a chalk line made before its beak (Kircher's *experimentum mirabile*, 1644). Birds, rabbits, and frogs remain passive for a time after they have been gently stroked on the back for a time. Crayfish stand on their head and claws (Czermak).

375. The Motor Cortical Centres of the Cerebrum.

[In connection with the localisation of the centres in the cortex, it is important to be thoroughly acquainted with the arrangement of the cerebral convo-

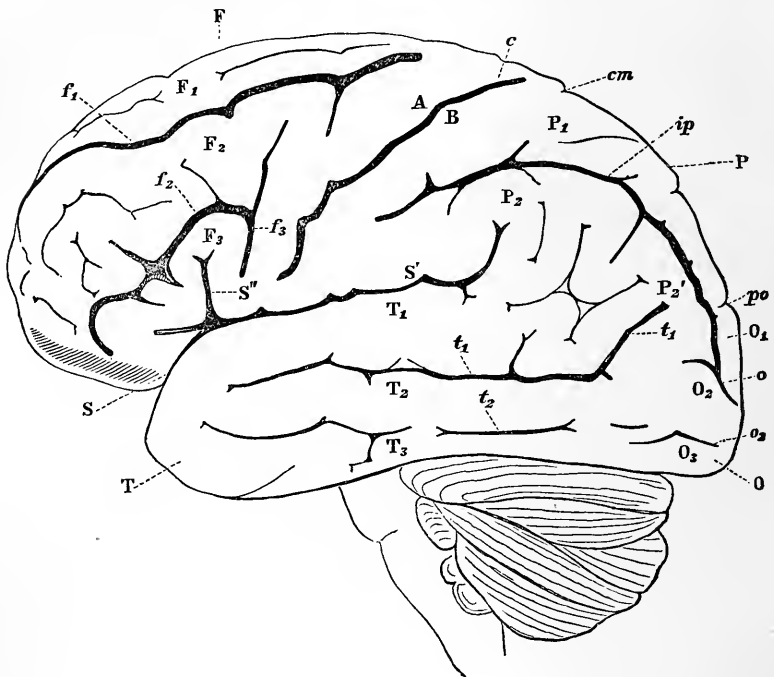

Fig. 353.

Left side of the human brain, partly diagrammatic (after Ecker)—F, frontal lobe ; P, parietal lobe ; O, occipital lobe ; T, temporo-sphenoidal lobe ; S, fissure of Sylvius ; S', horizontal ; S'', ascending ramus of S ; c, sulcus centralis, or fissure of Rolando ; A, ascending frontal, and B, ascending parietal convolution ; F₁, superior, F₂, middle, and F₃, inferior frontal convolutions ; f₁, superior, and f₂, inferior frontal fissures ; f₃, sulcus præcentralis ; P, superior parietal lobule ; P₂, inferior parietal lobule, consisting of P₂, supra-marginal gyrus, and P₂', angular gyrus, ip sulcus interparietalis ; cm, termination of callosomarginal fissure ; O₁, first, O₂, second, O₃, third occipital convolutions ; po, parietal-occipital fissure ; o, transverse occipital fissure ; o₂, inferior longitudinal occipital fissure ; T₁, first, T₂, second, T₃, third temporo-sphenoidal convolutions ; t₁, first, t₂, second temporo-sphenoidal fissures.

lutions. Each half of the cerebral surface is divided by certain *fissures* into five lobes—*frontal*, *parietal*, *occipital*, *temporo-sphenoidal*, and *central*, or *Island of Reil* (Fig. 353). The **frontal** lobe (Fig. 353) consists of three convolutions, with numerous secondary folds running nearly horizontal, named superior (F_1), middle (F_2), and inferior (F_3) frontal convolutions. Behind these is a large convolution, the ascending frontal (A), which ascends almost vertically, immediately behind these, separated from them, however, by the præcentral fissure (f_3), and mapped off behind by the fissure of Rolando, or the central sulcus (c).]

[The **parietal** lobe (Fig. 353, P) is limited in front by the fissure of Rolando, below in part by the Sylvian fissure, and behind by the parieto-occipital fissure. It consists of the ascending parietal (posterior central) convolution (Fig. 353, B), which ascends just behind the fissure of Rolando, and parallel to the ascending frontal, with which it is continuous below; above, it becomes continuous with the superior parietal lobule (P_1), while the latter is separated from the inferior parietal lobule (*pli courbe*) by the inter-parietal sulcus. The inferior parietal lobule consists of (a) a part arching over the upper end of the Sylvian fissure, the supra-marginal convolution (P_2), which is continuous with the superior temporo-sphenoidal convolution. Behind is (b) the angular gyrus (P_2'), which arches round the posterior end of the parallel fissure, and becomes connected with the middle temporo-sphenoidal convolution.]

[The **temporo-sphenoidal** lobe (Fig. 353, T) consists of three horizontal convolutions—superior, middle, and inferior—the two former being separated by the parallel sulcus, while the whole lobe is mapped off from the frontal by the Sylvian fissure (S).]

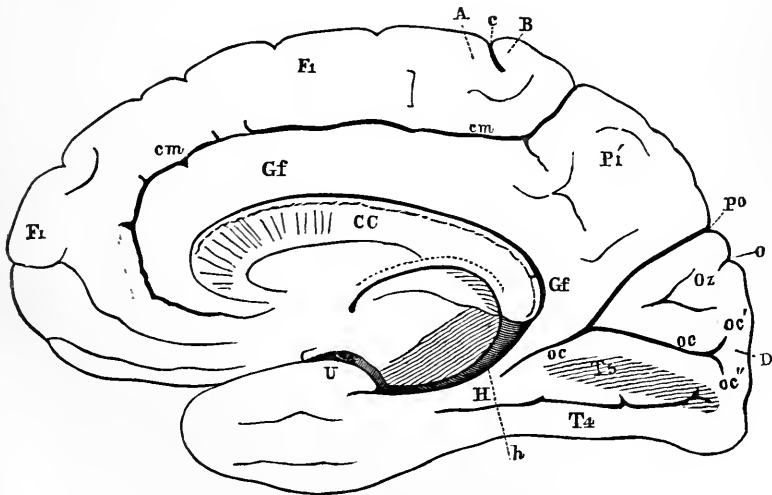

Fig. 354.

Median aspect of the right hemisphere (after Ecker)—CC, corpus callosum divided longitudinally; Gf, gyrus fornicatus; H, gyrus hippocampi; h, sulcus hippocampi; U, uncinatus gyrus; cm, callosal-marginal fissure; F, first frontal convolution; c, terminal portion of fissure of Rolando; A, ascending frontal; B, ascending parietal convolution; PI', præcuneus; Oz, cuneus; Po, parieto-occipital fissure; o₁, transverse occipital fissure; oc, calcarine fissure; oc', superior, oc'', inferior ramus of the same; D, gyrus descendens; T₄, gyrus occipito-temporalis lateralis (lobulus fusiformis); T₅, gyrus occipito-temporalis medialis (lobulus lingualis).

[The **occipital** lobe (Fig. 353, O) is small, forms the rounded posterior end of the cerebrum, and is separated from the parietal lobe by the parieto-occipital fissure, which fissure is bridged over at the lower part by the four annectent gyri (*plis de passage* of Gratiolet). It has three convolutions—superior (O₁), middle (O₂), and inferior (O₃) on its outer surface.]

[The **central** lobe, or **Island of Reil**, consists of five or six short, straight convolutions (gyri operi—Fig. 355), radiating outwards and backwards from near the anterior perforated spot, and can only be seen when the margins of the Sylvian fissure are pulled asunder. The operculum, consisting of the extremities of the inferior frontal, ascending parietal and frontal convolutions, lie outside it.]

[On the *inner* or *mesial* surface of the cerebrum are—

The **gyrus fornicatus** (Fig. 354, Gf), or convolution of the corpus callosum, which runs parallel to and bends round the anterior and posterior extremities of the corpus callosum, terminating posteriorly in the gyrus uncinatus or gyrus hippocampi (Fig. 354, H), and ending anteriorly in crooked extremity, the subiculum cornu ammonis (Fig. 354, U). Above it is the calloso-marginal fissure (Fig. 354, *cm*), and running parallel to it is the **marginal** convolution (Fig. 354), which lies between the latter fissure and the margin of the longitudinal fissure; it is, however, merely the mesial aspect of the frontal and parietal convolutions. The *quadrate lobule* or *præcuneus* lies (Fig. 354, Pi) between the posterior extremity of the calloso-marginal fissure and the parieto-occipital fissure; it is merely the mesial aspect of the ascending parietal convolution. The parieto-occipital fissure terminates below in the *calcarine fissure* (Fig. 354, *oc*), and the latter runs backwards in the occipital lobe dividing it into two branches, *oc'*, *oc''*. Between the parieto-occipital and calcarine fissures lies the wedge-shaped lobule termed the *cuneus* (Fig. 354, *oz*). The calcarine fissure indicates on the surface the position of the *calcar avis* or *hippocampus minor*, in the posterior cornu of the lateral ventricle. The *dentate fissure* or *sulcus hippocampi* (Fig. 354, *h*), marks the position of the elevation of the hippocampus major, or cornu ammonis, in the lateral ventricle. The *temporo-sphenoidal lobe* terminates anteriorly in the uncinatus gyrus, while, running along the former and the occipital lobes, is the *collateral fissure* (occipito-temporal sulcus), which marks the position of the *emenitia collateralis* in the descending cornu

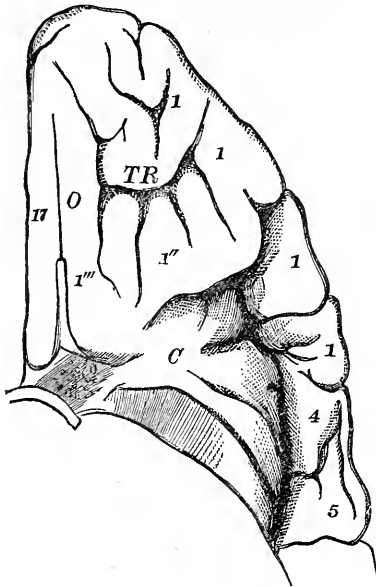

Fig. 355.

Orbital surface of the left frontal lobe and the Island of Reil, the tip of the temporo-sphenoidal lobe removed to show the latter (after Turner)—17, convolution of the margin of the longitudinal fissure; O, olfactory lobe removed; TR, triradiate fissure; 1'' and 1''', convolutions on the orbital surface; 1, 1, 1, 1, under surface of the infero-frontal convolution; 4, under surface of the ascending frontal, and 5, of the ascending parietal convolutions; C, central lobe or island.

campus minor, in the posterior cornu of the lateral ventricle. The *dentate fissure* or *sulcus hippocampi* (Fig. 354, *h*), marks the position of the elevation of the hippocampus major, or cornu ammonis, in the lateral ventricle. The *temporo-sphenoidal lobe* terminates anteriorly in the uncinatus gyrus, while, running along the former and the occipital lobes, is the *collateral fissure* (occipito-temporal sulcus), which marks the position of the *emenitia collateralis* in the descending cornu

of the lateral ventricle, while it also separates the *superior* from the *inferior* temporo-occipital convolutions (T_4 and T_5).]

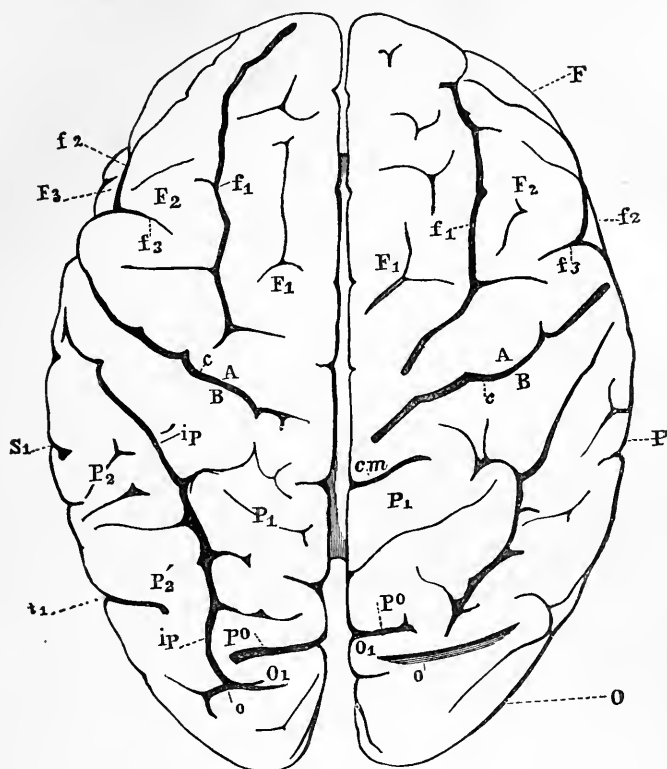

Fig. 356.

View of the brain from above, semi-diagrammatic— S_1 , end of ramus of the Sylvian fissure. The other letters refer to the same parts as in Fig. 353.

[The general arrangement of these lobes, convolutions, and fissures, is shown in Figs. 353, 354, 355, 356.]

Motor Centres.—Fritsch and Hitzig (1870) discovered a series of circumscribed regions on the surface of the cerebral convolutions, whose stimulation, by means of electricity, causes *movements* in quite distinct groups of muscles of the *opposite* side of the body (Fig. 357, I, II).

Methods.—The surface of the cerebrum is exposed in an animal (dog, monkey), by removing a part of the skull covering the so-called motor convolutions, and dividing the dura mater. When the convolutions are freely exposed, a pair of blunt non-polarisable (§ 328) needle electrodes are applied near each other to various parts of the cerebral surface. We may employ the closing or opening shock of a **constant** current, or the constant current may be rapidly interrupted; the current being of such a strength as to be distinctly perceived when it is

applied to the tip of the tongue (Fritsch and Hitzig). Or the **induced** current may be used (Ferrier, 1873), of such a strength that it is readily felt when applied to the tip of the tongue. The *cerebrum* is completely *insensible to severe operations made upon it*.

The areas of the cerebral cortex, whose stimulation discharges the characteristic movements, are regarded as *actual centres*, because the reaction time after stimulation of the centres, and the duration of the muscular contraction, are longer than when the sub-cortical fibres, which lead towards the deeper parts of the brain, are stimulated. Another circumstance favouring this view is, that the excitability of these areas is influenced by the stimulation of afferent nerves (Bubnoff and Heidenhain). It is probable that these centres are acted upon by voluntary impulses in the execution of voluntary movements. Hence, they may be called "*psychomotor centres*." The motor areas of the cerebrum (dog, cat, sheep) are characterised by the presence of specially large pyramidal cells (Betz, 1874; Merzejewsky, Bevan Lewis); while similar cells were found by Obersteiner in the areas marked 4 and 8 (Fig. 357), and Betz found them in the anterior central convolution of man, in the third frontal convolution, and in the Island of Reil. O. Soltmann found that, stimulation of the motor areas in *newly-born* animals is without result, while only the deeper fibres of the corona radiata are excitable.

Modifying Conditions.—In the condition of *deep* narcosis, produced by chloroform, ether, chloral, morphia, or in apnœa, the excitability of the centres is abolished (Schiff), whilst the subcortical conducting paths still retain their excitability (Bubnoff and Heidenhain). Small doses of these poisons and also of atropin at first increase the excitability of the centres. Moderate loss of blood excites them, while a great loss of blood diminishes and then abolishes the excitability (Munk and Orschansky). Slight inflammation increases, while cooling diminishes, the excitability. If the cortex cerebri be removed in animals, the excitability of the fibres of the corona radiata is completely abolished about the fourth day, just as in the case of a peripheral nerve separated from its centre (Albertoni, Michieli, Dupuy, Franck, and Pitres).

As the fibres of the corona radiata (or projection system of the first order) converge towards the centre of the hemisphere, it is evident that, after removal of the cortex, stimulation of these fibres in the deeper parts of the hemisphere is followed by the same motor results (Gliky and Eckhard). The stimulus is applied merely to a deeper part of the motor path. If the stimulus be applied to parts situated still more deeply, as for example, to the *internal capsule*, general contraction of the muscles on the opposite side is the result.

Time Relations of the Stimulation.—According to Franck and Pitres, the time which elapses between the moment of stimulation of the cortex and the resulting movement, after deducting the period of latent stimulation for the muscles, and the time necessary for the conduction of the impulse through the cord and nerves of the extremities, is 0·045 second. Heidenhain and Bubnoff found that, during moderate morphia-narcosis, when the stimulating current was increased in strength, the muscular contraction and the reaction time became shorter. After removal of the cortex, the occurrence of the muscular contraction, from the moment of stimulation of the white matter, is diminished $\frac{1}{4}$ to $\frac{1}{3}$. The form of the

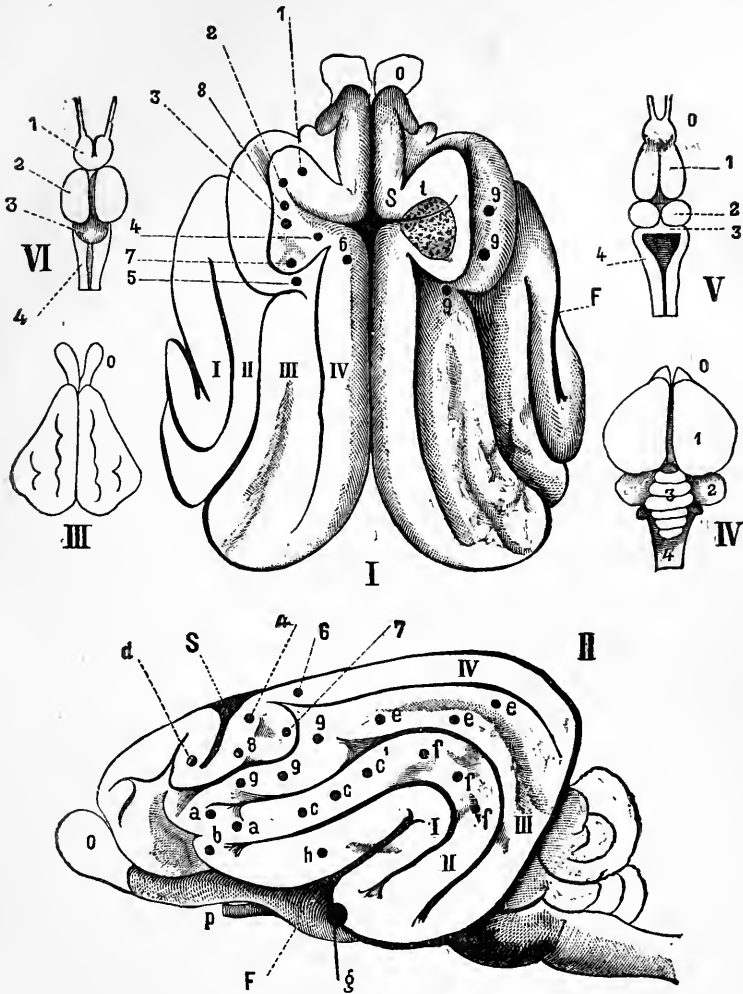

Fig. 357.

I, Cerebrum of the dog from above; II, from the side; I, II, III, IV, the four primary convolutions,—*S*, sulcus cruciatus; *F*, Sylvian fossa; *o*, olfactory lobe; *p*, optic nerve; 1, motor area for the muscles of the neck; 2, extensors and adductors of the fore limb; 3, Flexors and rotators of the fore limb; 4, the muscles of the hind limb; 5, the facial muscles; 6, lateral switching movements of the tail; 7, retraction and abduction of the fore limb; 8, elevation of the shoulder and extension of fore limb (movements as in walking); 9, 9, Orbicularis palpebrarum, zygomaticus, closure of the eye-lids. II—*a*, *a*, Retraction and elevation of the angle of the mouth; *b*, opening of the mouth and movements of the tongue (oral centre); *c*, *c*, platysma; *d*, opening of the eye; *I*, *t*, thermic centre, according to Eulenburg and Landois. Fig. III, Cerebrum of the rabbit from above; IV, Cerebrum of the pigeon from above; V, Cerebrum of the frog from above; VI, Cerebrum of the carp from above—(in all these *o* is the olfactory lobe—1, cerebrum; 2, optic lobe; 3, cerebellum; 4, medulla oblongata.)

muscular contraction is longer and more extended, when the cortex, than when the subcortical paths are stimulated. If the animal (dog) be in a state of high reflex excitability, these differences disappear; in both cases the contraction follows very rapidly (Bubnoff and Heidenhain). If the stimulus be very strong, the muscles of the *same* side may contract, but somewhat *later* than those of the opposite side. If the motor areas for the fore and hind limbs be stimulated simultaneously, the latter contract somewhat after the former.

If 40 stimuli per second be applied to a motor area, then the corresponding muscles yield 40 single contractions; while, with 46 single stimuli per second, there results a continued complete contraction. In one and the same animal, the *same number of stimuli* is required to produce a continuous contraction, whether the cortical centre, the motor nerve, or even the muscle itself, be stimulated. With very feeble stimuli, *summation of stimuli* takes place, for the muscular contraction only begins after several ineffective stimuli have been applied.

Primary Fissures and Convolutions of the Dog's Brain.—The *position* of the motor centres in the dog's brain is indicated in Fig. 357, I and II. The dog's brain is marked by two "primary fissures," viz., the *sulcus cruciatus* (Leuret) (S), which intersects the longitudinal fissure, at a right angle, at the junction of its anterior with its middle third. This fissure has been called the *sulcus frontalis* (Owen), or the *fissura coronalis*. The second primary fissure is the *fossa Sylvii* (F). Four "*primary convolutions*," in addition, are arranged with reference to these primary fissures. The first primary convolution (I), in the form of a sharply curved knee, embraces the *fossa Sylvii* (F). The second convolution (II) runs nearly parallel to the first. The fourth primary convolution (IV) bounds the longitudinal fissure, and is separated from its fellow of the opposite side by the *falx cerebri*; anteriorly it embraces the *sulcus cruciatus* (S), so that it is divided into two parts by this sulcus, a part, the *gyrus praecruciatu*s, or *praefrontalis*, lying in front of the sulcus, and the *gyrus posteruciatu*s (*postfrontalis*) lying behind it. The third primary convolution (III) runs parallel to the fourth. Some authors count the convolutions, from the longitudinal fissure, outwards.

In Fig. 357, I and II, the *motor areas* or *centres* are indicated by dots in the individual primary convolutions. We must remember, however, that the centres are not mere points, but that they vary in size from that of a pea, upwards, according to the size of the animal. Motor areas have been mapped out in the brain of the monkey, rabbit, rat, bird, and frog.

Position of the Motor Centres (Dog).—Fritsch and Hitzig, in 1870, mapped out the following motor areas, whose position may be readily found on referring to Fig. 357:—1, is the centre for the *muscles of the neck*; 2, for the extensors and adductors of the *fore-limb*; 3, for the flexion and rotation of the fore-leg; 4, for the movements of the *hind-limb*, which Luciani and Tamburini resolved into two antagonistic centres; 5, for the *muscles of the face*, or the facial centre. In 1873, Ferrier discovered the following additional centres:—6, for the lateral switching movements of the *tail*; 7, for the retraction and abduction of the fore-limb; 8, for the elevation of the shoulder and extension of the fore-limb, as in walking; the area marked 9, 9, 9, controls the movements of the *orbicularis palpebrarum*, and of the *zygomaticus* (closure of the eyelids), together with the upward movement of the eyeball and narrowing of the pupil. Stimulation of the areas, *a, a*, (Fig. II) is followed by retraction and elevation of

the angle of the mouth, with partial opening of the mouth; at *b*, Ferrier observed opening of the mouth with protrusion and retraction of the tongue, while the dog not unfrequently howled. He called this centre, the "*oral centre*." Stimulation of *cc* causes retraction of the angle of the mouth, owing to the action of the platysma, while *c'* causes elevation of the angle of the mouth and of one-half of the face, until the eye may be closed, just as in 9. Stimulation of *d* is followed by opening of the eye and dilatation of the pupil, while the eyes and head are turned towards the other side. According to H. Munk, the fore-brain has an influence upon the attitude of the body. The perineal muscles contract when the gyrus posterucius is stimulated. Stimulation of the gyrus praecrucius on its anterior and sloping aspect, causes movements in the pharynx and larynx.

The position of the individual motor areas may vary somewhat, and they may be slightly different on the two sides (Luciani and Tamburini).

Strong Stimuli.—If the stimulation be very strong, not only the muscles on the opposite side contract, but those on the same side may also contract. These latter movements belong to the class of associated movements, and are due to conduction through commissural fibres. Those muscles, which usually (muscles of mastication), or always (muscles of eye, larynx, and face) act together, appear to have a centre not only in the opposite but also in the hemisphere of the same side (Exner).

Mechanical stimulation has no effect upon these centres. Landois and Eulenburg observed, that **chemical** stimulation of these centres by means of common salt caused movements in the extremities.

Cerebral Epilepsy.—It is of great practical diagnostic importance to ascertain if stimulation of the motor areas in man, due to local diseases (inflammation, tumours, softening, degenerative irritation), causes movements. Hughlings-Jackson answers in the affirmative, and explains in this way the occurrence of unilateral, local epileptiform spasms, which were observed by Ferrier and Landois to occur after inflammatory irritation. Luciani observed these spasms in dogs, and sometimes they were so violent and general as to constitute an attack of epilepsy. This condition became hereditary, and the animals ultimately died from epilepsy (p. 902). According to Eckhard, epileptic attacks are never produced by stimulation of the surface of the posterior convolutions.

Strong stimulation of the motor regions gives rise in dogs to a complete general convulsive, *epileptic* attack, which usually begins with contractions of the groups of muscles specially related to the stimulated centre (Ferrier, Eulenburg and Landois, Albertoni, Luciani and Tamburini), then often passes to the corresponding limb of the opposite side (associated movements); and, lastly, all the muscles of the body are thrown into tonic and then into clonic spasms. The opposite side of

the body has been observed to pass into spasm from below upwards, after the contractions were developed in the other side. The spasmodic excitement passes from centre to centre, an intermediate motor region never being passed over. Sometimes feeble stimulation above the internal capsule is sufficient to cause this condition. After this condition has once been produced, the slightest stimulation may suffice to bring on a new epileptic attack (§ 373).

Stimulation of the *subcortical* white matter causes epilepsy, which, however, begins in the muscles of the *same* side (Bubnoff and Heidenhain). These contractions are due to an escape of the electrical current, which thus reaches the medulla oblongata (§ 373).

If certain motor areas are extirpated, the epileptic attack is absent from the muscles controlled by these areas (Luciani). Separation of the motor cortical area by means of a horizontal section *during* an attack cuts short the latter (Munk). During an epileptic attack, it is possible to excise the motor area of one extremity, and thus exclude this limb from the attack, whilst the rest of the body is convulsed.

The continued use of *potassium bromide* prevents the possibility of producing epilepsy on stimulating the cortical areas. *Atropin* in small doses increases the excitability of the motor areas, while in large doses it paralyses them.

Extirpation of the motor centres is followed by characteristic disturbances of movement in the corresponding muscles on the opposite side of the body. Destruction of the motor areas for the extremities makes the latter powerless, and their movements become awkward. Some observers characterise these phenomena as always merely temporary, but Landois has observed them to persist for months. In dogs, especially, the feet are paralysed for all those movements in which they are, to a certain extent, used as hands (Goltz)—*i.e.*, those movements acquired by special training. Clinical observations on man show that degeneration of the motor cortical areas results in downward degeneration of the pyramidal tracts—*i.e.*, the tracts for voluntary movements (§ 365), and in monkeys there is atrophy of the corresponding muscles (Schiff). [Ferrier has shown that, when the centre for the movements of the arm of a monkey is extirpated, there is paralysis of the arm on the opposite side of the body, and subsequently, the arm exhibits contracture from the descending degeneration which takes place.]

The higher the development of the intelligence of the animals, the more their movements have been learned, and have gradually come to be controlled by the will; in them the disturbance of the motor phenomena becomes more pronounced and persistent after destruction of the cortical psychomotor centres. Whilst in the lower vertebrates, including the birds, extirpation of the whole hemispheres does not materially interfere with the movements, the co-ordinated reflex movements being sufficient; in dogs occasionally, extirpation of several motor areas produces visible permanent disturbance of motor acts, which in monkeys and man (§ 378) may be intense and of long duration.

Among the movements performed by men are many which have been acquired after much practice, and have been subjected to voluntary control—*e.g.*, the movements of the hands for many manual occupations. After a lesion of the psychomotor centres, such movements are reacquired only very slowly and incompletely, or it may be not at all. Those movements, however, which are, as it

were, innate, and are under the control of the will without much practice—such as the associated movements of the eyes, face, some of those of the limbs—are either rapidly restored after the lesion, or they appear to suffer but slightly. After a lesion of the cerebral cortex, the facial muscles are never so completely paralysed as from a lesion of the trunk of the facial nerve; usually the eye can be closed in the former case. The movements necessary for sucking have been performed by a hemicephalic infant.

Theoretical.—Hitzig ascribes the disturbance of movement, after removal of the motor centres, to the loss of the "*muscular sensibility*." Schiff ascribes it to the loss of *tactile sensibility*. According to Ferrier, the tactile and sensory impressions are not appreciably diminished or altered.

The descending degeneration of the pyramidal tracts in the lateral columns, according to Schiff, occurs after section of the posterior half of the cervical spinal cord, or even after section of the posterior part of the lateral columns. After dividing the latter, and allowing secondary degeneration to take place, it is not possible to discharge movements by stimulating the cortex cerebri. The posterior columns and their continuation upwards to the brain, carry the impulses upwards to the cerebrum (ascending limb of the reflex arc), where, after being modified in the centres, they are carried outwards by the pyramidal tracts (descending limb of the reflex arc). Between, but deeper in the brain, lie the centres for tactile sensibility. Landois and Eulenburg observed in a dog, from which the motor centres for the extremities had been removed on *both* sides, that the movements became completely *ataxic*—i.e., the animal could not execute such co-ordinated movements as walking, standing, &c. Goltz regards the disturbances of movement after injury of the cortex as due to inhibition.

Schiff maintains that, when the cortex cerebri is stimulated, we do not stimulate a cortical centre, but only the sensory channels of a reflex arc, the continuation of the posterior columns, so that on this supposition the movements resulting from stimulation of the motor points would be reflex movements. The centres lie deeper in the brain. This view is not generally entertained.

Modifying Conditions.—The excitability of the motor centres is capable of being considerably modified. Stimulation of sensory nerves diminishes it; thus the curve of contraction of the muscles becomes lower and longer, while the reaction time is lengthened simultaneously. Only when, owing to strong stimulation the reflex muscular contractions are vigorous, the excitability of the cortical centres appears to be increased. Specially noteworthy is the fact that, in a certain stage of *morphia-narcosis*, a stimulus which is too feeble to discharge a contraction, immediately becomes effective, if immediately before the stimulus is applied to the cortical centre, the skin of certain cutaneous areas be subjected to gentle tactile stimulation. When *strong* pressure is applied to the foot, the contractions become tonic in their nature, so that all stimuli which, under normal conditions, produce only temporary stimulation, now stimulate these centres continuously. If during the tonic contraction, one gently strokes the back of the foot, blows on the face, gently taps the nose, or stimulates the sciatic nerve, suddenly relaxation of the muscles again occurs.

These phenomena call to mind the analogous observations in hypnotised animals (§ 374). Another very remarkable observation

is that, when either owing to a reflex effect, or owing to *strong* electrical stimulation of a cortical centre, contracture of the corresponding muscles is produced, then *feeble* stimulation of the same centre, but also of other centres, suppresses the movement. Thus we have the remarkable fact that, according to the strength of the stimulus applied to the motor apparatus, we can either produce movement or suppress a movement already in progress (Bubnoff and Heidenhain).

376. The Sensory Cortical Centres.

The investigations of Ferrier and H. Munk point to the conclusion that, in certain areas of the cortex cerebri, the act of conscious sensory perception is accomplished. These points or areas are connected by means of fibres with the nerves of sense; and may, therefore, be termed sensory cortical centres, or "*psycho-sensorial centres.*" The total destruction of such a centre abolishes the conscious perception excited through the corresponding organ of sense.

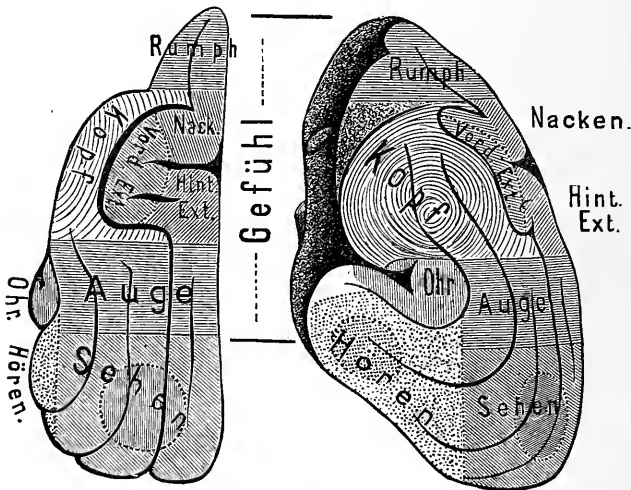

Fig. 358.

The psycho-optic and psycho-acoustic centre, and the other so-called "sensory centres" of the dog's brain (H. Munk)—Gefühl = feeling; Nacken = neck; Kopf = head; Auge = eye; Ohr = ear; Sehen = sight; Hören = hearing; Rumpf = trunk; Vord. and Hint. Ext. = fore and hind limbs.

When these centres are *partially* disorganised, the mechanism of the sensory activity may remain intact, but "the conscious link is wanting." A dog with its centres thus destroyed sees, hears, or smells, but it no longer knows what it sees, hears, or smells. These

centres are in a certain sense the seat of experience that has been acquired through the organs of sense. *Stimulation* of these centres may give rise to movements, such as occur when sudden, intense sensory impressions are produced. These movements, therefore, are to be regarded as reflex, partly as extensive, co-ordinated reflex movements, and are in no way to be confounded with the movements which result from direct stimulation of the motor cortical centres. To this belongs dilatation of the pupil and the fissure of the eyelids, as well as lateral movements of the eyeball (Unverricht).

1. The psycho-optic centre, or the "visual centre," according to Munk, embraces the outer convex part of the occipital lobe of the dog's brain (Fig. 358) marked with the word "sehen." [This centre and its connections are represented in Fig. 359. It is, therefore, in the area supplied by the posterior cerebral artery.] If this region be completely destroyed, the dog remains permanently blind ("cortical or absolute blindness") in the eye of the opposite side. If, however, only the central circular area be destroyed, there is loss of the conscious visual sensation of the opposite side, which may be called "*psychical blindness*" (Munk), or amnesia optica. It is remarkable that, after unilateral destruction of this part, compensation takes place; it is as if other neighbouring cortical areas of the visual sphere assume the function of the injured part. It seems that animals must again learn to see with the affected eye, just as is the case in early youth (Munk).

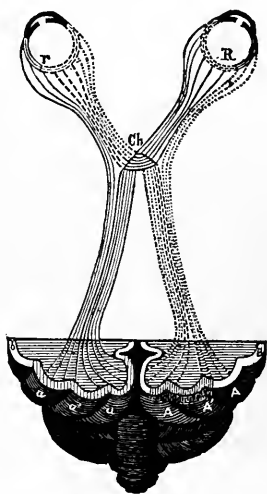

Fig. 359.

Course of the psycho-optic fibres (after Munk).

Mauthner denies the existence of cortical blindness, and believes that after destruction of the middle of the visual centre, the reason why the dog does not recognise the object with the opposite eye is because, owing to there being only indirect vision, there is no distinct impression on the retina. The position of the visual centre has been variously stated by different observers. According to Ferrier, in the dog, it lies in the occipital part of the III primary convolution, near the spot marked *e, e, e*, in Fig. 357; according to his newer researches, in the occipital lobe and gyrus angularis.

Connection with the Retina.—Munk discovered (in dogs) that *both* retinae are connected with each psycho-optic cortical centre, and in such a manner that the greatest part of each retina is connected with the *opposite* cortical centre, and only by its most external lateral marginal part with the centre of the *same* side. If we imagine the surface of *one*

retina to be projected upon the centres, then the most external margin of the first is connected with the centre of the *same* side, the inner margin of the retina with the inner area of the *opposite* centre, the upper margin with the anterior area, and the lower marginal part of the retina with the posterior area of the opposite side. The (shaded) middle of the centre corresponds to the position of direct vision of the retina of the *opposite* side (Fig. 358)—compare § 344.

Stimulation of the visual centre in dogs causes movements of the eyes towards the other side, sometimes with similar movements of the head, and narrowing of the pupils. If one eye be excised from newborn dogs, the opposite psycho-optic centre, after several months, is less developed (Munk).

After *extirpation* of the visual centre in young dogs, the channels which connect it with the optic nerve undergo degeneration (v. Monakow).

Bilateral destruction of the whole centre gives rise to total blindness on both sides, while destruction of the central (shaded) part alone causes psychical blindness on both sides in the dog.

In monkeys the centre lies at the tip of the occipital lobe. Unilateral destruction causes blindness of the halves of *both* retinae lying on the side of the injury. The visual centre in pigeons (Fig. 357, IV, where 1 is placed) lies somewhat behind and internal to the highest curvature of the hemispheres (M'Kendrick, Ferrier, Musehold). The visual centre in the frog lies in the optic lobe (Blaschko).

[Ferrier and Yeo find that destruction of both angular gyri and occipital lobes causes total and permanent blindness in both eyes in monkeys, without any impairment of the other senses or motor power.]

2. The **psycho-acoustic centre** or "**auditory area**" lies, in the dog, according to Ferrier, in the region of the second primary convolution at *f, f, f* (Fig. 357, II), while Munk locates it in the temporo-sphenoidal lobes (Fig. 358) indicated by the word "*hören*." Destruction of the entire region causes deafness of the *opposite* ear, while destruction of the middle shaded part alone causes "*psychical deafness*" (*Seelentaubheit*—Munk) or *amnesia acustica*. Stimulation of the centre is followed by a reaction which closely resembles that produced by a sudden fright, or that produced by a sudden unexpected noise. The ear-muscles are moved in different directions, [the animal pricks its ears] (Ferrier). After *unilateral* injury of the middle part of the centre, the disturbance thereby produced is equilibrated, after several weeks, just as in the case of the psycho-optic centre, so that the animal must again *learn* to hear (Munk). Destruction of the middle part on both sides gives rise to psychical deafness on both sides. Such dogs no longer prick their ears to auditory impressions, and they cease to bark. The anterior parts of the auditory spheres appear to be connected with the percep-

tion of higher, and the posterior parts with the perception of lower tones (Munk). After unilateral extirpation of one ear in newly-born puppies, Munk observed that the opposite centre was less developed. Destruction of the *whole* region on both sides causes permanent deafness. Ferrier determined the existence of the centre in the monkey, rabbit, jackal, and cat.

[Ferrier locates the centre for hearing in the monkey in the *superior temporo-sphenoidal convolution*, and he finds that when the centres on both sides are *extirpated* the animal is absolutely deaf; it takes no cognisance of a pistol fired in its neighbourhood.]

3. The olfactory centre is placed in the dog in the gyrus hippocampi by Munk, while Ferrier locates the centres for smell (psycho-osmic) and taste (psycho-geusic) in the gyrus uncinatus, [smell in the subiculum cornu ammonis] and its neighbourhood (Fig. 357, II, *g*).

On stimulating these parts in monkeys, dogs, cats, and rabbits, he observed distortion of the lips and partial closure of the nostrils on the same side (§ 365). In man subjective olfactory and gustatory perceptions are regarded as irritative phenomena, while loss of these sensory activities, often complicated with other cerebral phenomena, are regarded as symptoms of their paralysis.

[4. Ferrier places the centre for tactile sensation in the *hippocampal* region, close to the distribution of part of the posterior cerebral artery. The centre for the sensation of pain has not been defined, probably it is very diffuse.]

5. Munk is of opinion that the surface of the cerebrum in the region of the motor centres acts at the same time as "sensory areas" ("*Fühl-sphäre*"), *i.e.*, they serve as centres for the *tactile* and *muscular* sensations and those of the innervation of the opposite side. The distribution of these areas for the individual parts of the body is indicated in Fig. 358. After injury to these regions the corresponding functions are affected.

According to Bechterew, the centres for the perception of tactile impressions, those of innervation, of the muscular sense, and painful impressions are placed in the neighbourhood of the motor areas (dog); the first immediately behind and external to the motor areas, the others in the region close to the origin of the Sylvian fissure.

Goltz, who first accurately described the disturbances of vision following upon injuries to the cortex in dogs, is opposed to the view of sensory localisation. He believes that each eye is connected with both hemispheres. He asserts that the disturbance of vision, after injury to the brain, consists merely in a diminished colour- and space-sense. The recovery of the visual perception of one eye after injury of one side of the cortex cerebri, he explains by supposing that this injury merely causes a temporary inhibition of the visual activity in the opposite eye, which disappears at a later period. Instead of psychical blindness and deafness, he speaks of a "cerebro-optical" and "cerebro-acoustical weakness."

377. The Thermal Cortical Centres.

A. Eulenburg and Landois discovered an area on the cortex cerebri whose stimulation produced an undoubted effect upon the temperature and condition of the blood-vessels of the opposite extremities. This region (Fig. 357, I, *t*), generally embraces the area, in which at the same time the motor centres for the flexors and rotators of the fore-limb (3), and for the muscles of the hind-limb (4) are placed. The areas for the anterior and posterior limbs are placed apart, that for the anterior limb lies somewhat more anteriorly, close to the lateral end of the crucial sulcus. *Destruction* of this region causes increase of the temperature of the opposite extremities; the temperature may vary considerably (1.5° to 2° , and even to 13°C). This result has been confirmed by Hitzig, Bechterew, Wood, and others. This rise of the temperature is usually present for a considerable time after the injury, although it may then undergo variations. Sometimes it may last three months, in other cases it gradually reaches the normal in two or three days. In well-marked cases, there is a diminution of the resistance of the wall of the femoral artery to pressure, and the pulse-curve is not so high (Reinke).

Local electrical *stimulation* of the area causes a slight temporary cooling of the opposite extremities, which may be detected by the thermo-electric method. Stimulation by means of common salt acts in the same way, but in this case the phenomena of destruction of the centre soon appear. As yet it has not been proved that there is a similar area for each half of the head. The cerebro-epileptic attacks (§ 375) increase the bodily temperature, partly owing to the increased production of heat by the muscles (§ 302), partly owing to diminished radiation of heat through the cutaneous vessels, in consequence of stimulation of the thermal cortical nerves. The experiments led to no definite results when performed on rabbits.

According to Wood, destruction of these centres occasions an increased production of heat that can be measured by calorimetric methods, while stimulation causes the opposite result.

These experiments explain how psychical stimulation of the cerebrum may have an effect upon the diameter of the blood-vessels and on the temperature, as evidenced by sudden paleness and congestion (§ 378, III).

Goltz's View.—Goltz uses a different method to remove the cortex cerebri—he makes an opening in the skull of a dog, and by means of a *stream of water* washes away the desired amount of brain matter. He describes, first of all, *inhibitory phenomena*, which are temporary and due to a temporary suppression of the activity of the nervous apparatus, which, however, is not injured anatomically,

but may be explained in the same way as the suppression of reflexes by strong stimulation of sensory nerves (§ 361, 3). In addition, there are the *permanent* phenomena, due to the disappearance of the activity of the nervous apparatus, which is removed by the operation. A dog with a large mass of its cerebral cortex removed may be compared to an eating, complex reflex machine. It behaves like an intensely stupid dog, walks slowly, with its head hanging down; its cutaneous sensibility is diminished in all its qualities—it is less sensitive to pressure on the skin; it takes less cognisance of variations of temperature, and does not comprehend how to feel; it can with difficulty accommodate itself to the outer world, especially with regard to seeking out and taking its food. On the other hand, there is no paralysis of its muscles. The dog still sees, but it does not understand what it does see; it looks like a somnambulist, who avoids obstacles without obtaining a clear perception of their nature. It hears, as it can be wakened from sleep by a call, but it hears like a person just wakened from a deep sleep by a voice—such a person does not at once obtain a distinct perception of the sound. The same is the case with the other senses. It howls from hunger, and eats until its stomach is filled; it manifests no symptoms of sexual excitement.

With regard to the localisation of the different centres in the cerebrum, Goltz obtained the following results:—He finds that a dog, with both parietal lobes destroyed, has its sensibility permanently blunted, its intelligence diminished, and is vicious; while, when both occipital lobes are destroyed, there is severe and permanent disturbance of vision. He supposes that every part of the brain is concerned in the functions of willing, feeling, perception, and thinking. Every section is, independently of the others, connected by conduction with all the voluntary muscles, and, on the other hand, with all the sensory nerves of the body. He regards it as possible that the individual lobes have different functions.

Inhibitory Phenomena.—Injury to the brain also causes inhibitory phenomena, such as the disturbances of motion, the complete hemiplegia which is frequently observed after large unilateral injuries of the cortex cerebri; these are regarded by Goltz as inhibitory phenomena due to the injury acting on lower infra-cortical centres whose action inhibits movement, but these movements are recovered as soon as the inhibitory action ceases.

378. Physiological Topography of the Human Cortex Cerebri.

We accept the arrangement of the convolutions according to Ecker, of which a short resumé is given in § 375.

I. The motor regions, which chiefly include the *anterior* (Fig. 360, A) and *posterior central convolutions*, the *præcentral lobule*, and reach backwards to the precuneus (Fig. 353), contain large ganglionic cells (Betz, Bevan Lewis, and Clarke), which, however, are found only after a child is one and a-half months' old (Korsch). [The central convolutions near the longitudinal fissure regulate the movements of the trunk and lower limbs, those in the middle of the ascending frontal and parietal convolutions the movements of the arms, while those in the operculum are connected with the movements of the face, tongue, lips, and hand, so that the fundamental movements depend on the first and the accessory on the last, viz.:—the centres in the operculum.]

Blood Supply.—These convolutions are supplied with blood from 4-5 branches of the Sylvian artery, which is not unfrequently plugged with an embolon. When a clot lodges in this artery, the branches to the basal ganglia may remain pervious, whilst the cortical branches may be plugged (Duret, Heubner—§ 381).

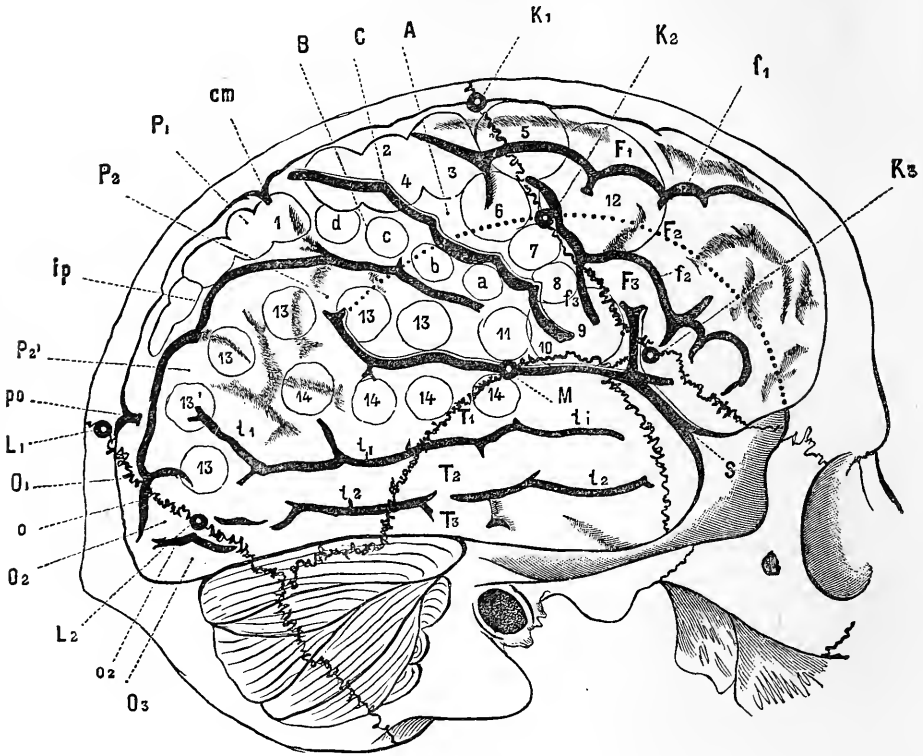

Fig. 360.

The brain with the chief convolutions (after Ecker). See also Figs. 353-356 in their relation to the skull. The numbers 1-14, and the letters *a-d*, indicate cerebral areas (see text)—*S*, Sylvian fissure, with its short vertical ascending ramus and its horizontal, posterior long ramus; *C*, central sulcus, or fissure of Rolando; *A*, anterior, and *B*, posterior central convolutions; *F*₁, upper, *F*₂, middle, and *F*₃, lowest frontal convolution; *f*₁, superior, and *f*₂, inferior frontal fissure; *f*₃, sulcus præcentralis; *P*₁, superior, *P*₂, inferior parietal lobe, with *P*₂, gyrus supra-marginalis; *P*₂¹, gyrus angularis; *ip*, sulcus interparietalis; *cm*, end of callosomarginal fissure; *O*₁, *O*₂, *O*₃, occipital convolutions; *po*, parieto-occipital fissure; *T*₁, *T*₂, *T*₃, temporo-sphenoidal convolutions; *K*₁, *K*₂, *K*₃, points in the coronal suture; 4₁, 4₂, in the lambdoidal suture.

[Fig. 360 shows the position of the motor centres or areas of the cerebral convolutions, according to Ferrier—(1) On the superior parietal lobule (advance of the opposite hind limb, as in walking). (2), (3), (4) Around the upper extremity of the fissure of Rolando (complex movements of the opposite leg and arm, and of

the trunk, as in swimming). (a), (b), (c), (d), On the ascending parietal or posterior central convolution (individual and combined movements of the fingers and wrist of the opposite hand or prehensile movements). (5) Posterior end of the superior frontal convolution (extension forward of the opposite arm and hand). (6) Upper part of the ascending frontal or anterior central convolution (supination and flexion of the opposite fore-arm). (7) Middle of the same convolution (retraction and elevation of the opposite angle of the mouth. (8) At the lower end of the same convolution (elevation of the ala nasi and upper lip, and depression of the lower lip on the opposite side). (9), (10), Broca's convolution (opening of the mouth with protrusion and retraction of the tongue—aphasic region). (11) Between 10 and the lower end of the ascending parietal convolution (retraction of the opposite angle of the mouth, the head turns towards one side). (12) Posterior part of the superior and middle frontal convolutions (the eyes open widely, the pupils dilate, and the head and eyes turn towards the opposite side). (13), (13') Supra-marginal and angular gyrus (the eyes move towards the opposite side, and upwards and downwards—centre of vision). (14) Superior temporo-sphenoidal convolution (pricking of the opposite ear, pupils dilate, and the head and eyes turn to the opposite side—centre of hearing).]

Degeneration of this entire motor area causes what Charcot has called *hémiplegie centrale vulgaire*, i.e., paralysis of the opposite half of the body, which is at first complete, but afterwards gradually passes into a condition in which all those movements under voluntary control, and especially those that have been learned, are abolished, whilst the associated and bilateral movements, which even animals can execute immediately after birth, remain more or less unaffected. Hence, the hand is more paralysed than the arm; this, again, than the leg; the lower facial branches more than the upper; the nerves of the trunk scarcely at all (Ferrier). The motor channels proceed from the motor cortical areas through the anterior two-thirds of the internal capsule, between the caudate nucleus and lenticular nucleus of the corpus striatum (Fig. 365).

In hemiplegic persons, the power of the unparalysed side is sometimes diminished (Brown-Séguard, Charcot, Pitres), which is not sufficiently explained by the fact that some bundles of the pyramidal tracts remain on the *same* side.

Some movements performed by man are learned only after much practice, and are only completely brought under the influence of the will after a time, such as the movements of the hand in learning a trade. Such movements are reacquired only very slowly, or not at all, after injury to the psycho-motor centres. Those movements, however, which the body performs without previous training, such as the associated movements of the eyeballs, the face, and some of those of the legs, are rapidly recovered after such an injury, or they suffer but little, if at all. Thus, the facial muscles seem never to be so completely paralysed after a lesion of the facial cortical centre as in affections of the trunk of the facial nerve, the eye especially can be closed. Sucking movements have been observed in hemicephalous fœtuses.

Degeneration of the Pyramidal Tracts.—After destruction of the cortical motor areas, descending degeneration of the cortico-motor paths takes place (§ 365). These fibres are spoken of as the "*pyramidal tracts*" (§ 365). Degenerative changes have been found to occur

within the white matter under the cortex, in the anterior two-thirds of the internal capsule, in the peduncle of the cerebrum, [in the middle third of the crusta, Fig. 361], pons, in the pyramids of the medulla oblongata, and from thence they have been traced into the pyramidal paths of the spinal cord (Charcot, Singer, M. Rosenthal). It is evident that lesions of these tracts at any part of their course must have the same result, viz., to produce hemiplegia. When the degenerative changes are taking place,

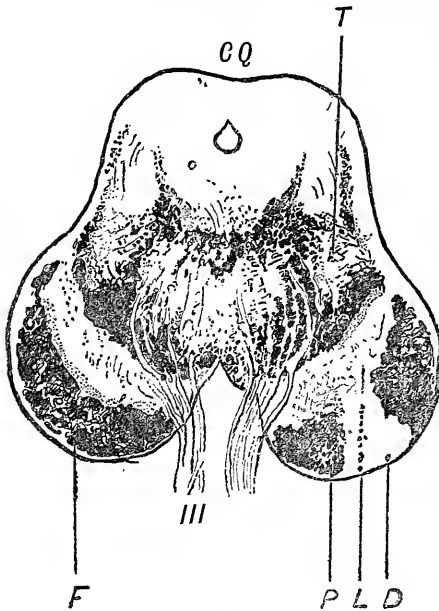

Fig. 361.

Horizontal section of the peduncular region in a case of secondary degeneration of the pyramidal tracts, where the lesion was limited to the middle third of the posterior segment of the internal capsule, L; T, tegmentum; F, crusta on the healthy side; L, locus niger; P internal fasciculus of the crusta on the diseased side. These fibres only undergo secondary degeneration when the fibres of the anterior segment and the knee of the internal capsule are diseased. D, secondary degeneration in the middle third of the crusta; C, Q, corpora quadrigemina with a section of the iter below it (Charcot).

(C, Fig. 360, 2, 3, 4, 1, *d, c*), and in the præcentral lobule (Fig. 362).
2. The centre for the *upper limb* lies in the middle third of the anterior central (ascending frontal) convolution, or a little lower (Fig. 360, 6, 7).

atrophic changes are taking place, the paralysed muscles have a certain degree of spastic rigidity [contracture], and there is an increase of the tendon reflexes. These are to be regarded as irritative degenerative phenomena (Charcot, Lion). In a case of congenital absence of the left fore-arm, Edinger found that the right central convolutions were less developed.

Ataxic motor conditions similar to those that occur in animals (p. 919) take place in man, and are known as *cerebral ataxia*.

Position of the Centres.—

In order to localise the individual motor partial centres, experiments have been made upon monkeys (Ferrier), but above all, well investigated clinical cases are most useful. These two methods have yielded fairly corresponding results.

The position of the cerebral areas is stated above.

1. The centre for the movements of the *leg* lie in the neighbourhood of the upper end of the fissure of Rolando.

The centre for the *face* lies at the lower end (8, 9), of the ascending frontal. The part of the ascending frontal convolution is in relation with the motor cranial nerves, especially with the facial and hypoglossal (Exner, Flechsig). The course to the facial and hypoglossal is through the knee of the inner capsule.

Monoplegia.—The motor centres may be paralysed singly or in groups, so that we have *cortical oculomotor monoplegia*, *crural* (rare), *brachial*—*brachio-crural* (especially after injury to the upper—median—part of the central convolutions—*linguo-facial*—and lastly, *facio-brachial* (especially after injury to the lower—lateral—part of the central convolutions).

Paralysis of the muscles of the neck and throat indicates a lesion of the central convolutions, and so does paralysis of the muscles of the eye. Lesions of the cortex always cause simultaneous movements of the head and eyeballs.

Stimulation of the Motor Centres.—If the motor centres are stimulated by pathological processes, such as hyperæmia, or inflammation in a syphilitic diathesis, more rarely by tumours, tubercle, cysts, cicatrices, fragments of bone—there arise spasmodic movements in the corresponding muscle-groups. This condition of local spasms is called "*Jacksonian*, or *cerebral epilepsy*."

Monospasm.—According to the seat of the spasm, it is called *facial*, *brachial*, *crural*, *monospasm*, &c. Of course, these spasms may affect several groups of muscles. Bartholow and Sciamanna have stimulated the exposed human brain successfully with electricity.

Cerebral Epilepsy.—Very powerful stimulation of *one* side may give rise to *bilateral* spasms, with loss of consciousness. In this case impulses are conducted to the other hemisphere by commissural fibres (§ 379).

Movements of the Eye.—Nothing definite is known regarding the centre in the cortex for voluntary *combined movements* of the eyeballs in man. In paralytic affections of the cortex and of the paths proceeding from it, we occasionally find both eyes with a lateral deviation. If the paralytic affection lies in one cerebral hemisphere, the conjugate deviation of the eyeballs is towards the sound side. If it is situated in the conducting paths, after these have decussated, viz., in the pons, the eyes are turned towards the paralysed side (Prévost).

If the part be irritated so as to produce spasms in the opposite half of the body, of course the eyes are turned in the opposite direction to that in pure paralysis (Landouzy and Grasset). Instead of the lateral deviation of the eyeballs, already described, occasionally in cerebral paralysis there is merely a *weakening* of the lateral recti muscles, so that during rest, the eyes are not yet turned towards the sound side, but they cannot be turned strongly towards the affected side (Leichtenstern, Hunnius). The centre for the levator palpebræ superioris appears to be placed in the gyrus angularis (Grasset, Landouzy, Chauffard).

II. The Centre for Speech.—The investigations of Bouillaud, Dax, Broca, Kussmaul, and others have shown that the *third left frontal con-*

volution of the cerebrum (Fig. 360, F, 3) is of essential importance for speech, while probably also the insula, or Island of Reil, which is seen to be deeply placed on lifting up the overhanging part of the brain called the operculum, lying between the two branches of the Sylvian fissure (S) is concerned. The motor centres for the organs of speech (lips, tongue) lie in this region, and in this region also the psychological processes in the act of speech are completed. In the great majority of mankind, the centre for speech is located in the *left* hemisphere. The fact that most men are *right-handed*, also points to a finer construction of the motor apparatus for the upper extremity, which must also be located in the left hemisphere. Men, therefore, with pronounced *right-handedness* (*droitiers*) are evidently *left-brained* (*gauchers du cerveau*—Broca). By far the greater number of mankind are "*left-brained speakers*" (Kussmaul); still there are exceptions. As a matter of fact, cases of *left-handed* persons have been observed who lost their power of speech after a lesion of the *right* hemisphere (Ogle, Habershon). Investigations on the brains of remarkable men have shown that, in them, the third frontal convolution is more extensive and more complex than in men of a lower mental calibre. In deaf-mutes it is very simple; microcephales and monkeys possess only a rudimentary third frontal (Rudinger).

The motor tracts for speech pass along the upper edge of the Island of Reil, then into the substance of the hemispheres internal to the posterior edge of the lenticular nucleus (Wernicke); and from thence through the crista of the left cerebral peduncle into the left half of the pons and into the medulla oblongata, which is the place where all the motor nerves (trigeminus, facial, hypoglossal, vagus, and the respiratory nerves) concerned in speech arise. Total destruction of these paths, therefore, causes total aphasia; while partial destruction causes a greater or less disturbance of the mechanism of articulation, which has been called "*anarthria*" by Leyden and Wernicke.

Conditions.—Three activities are required for speech—1, The normal movement of the vocal apparatus (tongue, lips, mouth, and respiratory apparatus); 2, a knowledge of the signs for objects and ideas (oral, written, or imitative, or mimetic signs); 3, the correct union of both.

Aphasia.—Injury of the speech centre causes either a loss, or more or less considerable disturbance of the power of speech. The loss of the power of speech is called "*aphasia*." [Aphasia, as usually understood, means the partial or complete loss of the power of articulate speech from cerebral causes.]

The following forms of aphasia may be distinguished:—

1. **Ataxic aphasia** (or the orolingual hemiparesis of Ferrier), *i.e.*, the loss of speech, owing to inability to execute the various movements of the mouth necessary for speech. Whenever such a person attempts to speak, he merely executes inco-ordinated grimaces, and utters inarticulate sounds. Hence, the patient cannot repeat what is said to him. Nevertheless, the *psychical* processes necessary for

speech are completely retained, and all words are remembered; and, hence these persons can still give expression to their thoughts graphically or by *writing*. If, however, the finely adjusted movements necessary for writing are lost, owing to an affection of the centre for the hand, then there arises at the same time the condition of **agraphia**, or inability to execute those movements necessary for writing. Such a person, when he desires to express his ideas in writing, only succeeds in making a few unintelligible scrawls on the paper. Occasionally such patients suffer from loss of the power of imitation or **aminia** (Kussmaul).

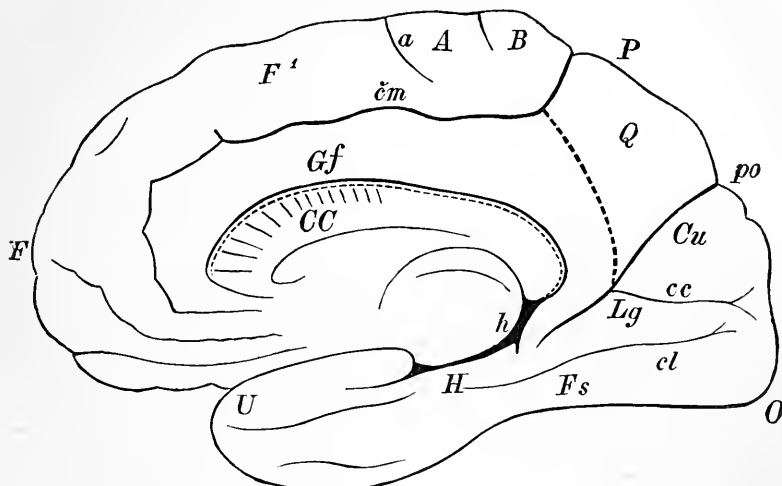

Fig. 362.

View of the *inner* surface of the human brain—*CC*, the corpus callosum divided; *F*¹, first frontal convolution, at *a* limiting the anterior central convolution, *A*; *B*, posterior central convolution; between *A* and *B*, the median end of the fissure of Rolando; *AB* is called the paracentral lobule; *Gf*, gyrus fornicatus, limited by the calloso-marginal fissure (*cm*) towards the 1st frontal convolution and the central convolutions; the calloso-marginal fissure passes between *B* and *P*, the upper temporal lobes, *po*, parieto-occipital fissure separating the occipital lobe (*O*) from the parietal lobes (*P*); *Q*, quadrate lobe, or precuneus; *Cu*, cuneus; *cc*, calcarine fissure; *Lg*, lingual lobule (gyrus occipito-temporalis medius); *Fs*, fusiform lobule (gyrus occipito-temporalis lateralis); *H*, gyrus hippocampi; *U*, gyrus uncinatus; *h*, sulcus hippocampi; *F*, frontal lobes.

2. Amnesic Aphasia, or Loss of the Memory of Words.—Should the patient, however, hear the word, its significance recurs to him. The movements necessary for speech remain intact; hence, such a patient can at once repeat or write down what is said to him. Sometimes only certain kinds of words are forgotten, or it may be even only parts of certain words, so that only part of these words is spoken. Cases of amnesic aphasia, or the mixed ataxic-amnesic form of disturbance of speech, point to a lesion of the third frontal convolution, and of the Island of Reil on the *left* side. Another form of amnesic aphasia consists in this, that the words remain in one's memory, but do not come when they are wanted—*i.e.*, the association between the idea and the proper word to give expression to it is inhibited (Kussmaul). It is common for old people to forget the names of persons

or proper names; indeed, such a phenomenon is common within physiological limits; and it may ultimately pass into the pathological condition of **amnesia senilis**. Amongst the disturbances of speech of *cerebral* origin, Kussmaul reckons the following:—

3. **Paraphasia**, or the inability to connect rightly the ideas with the proper words to express these ideas, so that, instead of giving expression to the proper ideas, the sense may be inverted, or the form of words may be unintelligible. It is as if the person were continually making a “slip of the tongue.”

4. **Agrammatism** and **ataxaphasia**, or the inability to form the words grammatically, and to arrange them synthetically into sentences. Besides these, there is—

5. A pathological, slow way of speaking (**bradyphasia**), or a pathological and stuttering way of reading (*tumultus sermonis*), both conditions being due to derangement of the cortex (Kussmaul). The disturbance of speech depending essentially upon affections of the *peripheral* nerves, or of the muscles of the organs of the voice and speech, are already referred to in § 319, § 349, and § 354.

III. The thermal centre of Eulenburg and Landois for the extremities, is associated with the motor areas. Injury or degeneration of these areas causes inequality of the temperature on both sides (Bechterew). In long standing paralysis, the initially high temperature of the affected limb may fall lower than that of the sound limb (compare p. 924).

In cases of insanity, with general progressive paralysis, due to inflammation of the cortex cerebri, the temperature of the axilla on the same side is usually higher on the side which is the seat of the paralysis.

In cases of *convulsions*, due to inflammatory irritation of the cortex cerebri, during the attack, the temperature on the same side as the centre is several tenths of a degree higher than on the other side (Reinhard).

IV. The sensory regions are those areas in which conscious perceptions of the sensory impressions are accomplished. Perhaps they are the substratum of sensory perceptions, and of the memory of sensory impressions.

1. The **psycho-optic centre**, according to Munk, Meynert, and Huguenin, includes the occipital lobes (Fig. 360, $0^1 0^2 0^3$), while, according to Exner, the first and second occipital convolutions are its chief seats. Huguenin observed in a case of long standing blindness, consecutive disappearance of the occipital convolutions on both sides of the parieto-occipital fissure, while Giovanardi, in a case of congenital absence of the eyes, observed atrophy of the occipital lobes, which were separated by a deep furrow from the rest of the brain. Stimulation of the centre gives rise to the phenomena of light and colour. Injury causes disturbance of vision, especially hemiopia of the same side (§ 344—Westphal, Jastrowitz, Curschmann, Jany). When *one* centre is the seat of irritation, there is photopsia of the same halves of both eyes (Charcot, Prinaud). Stimulation of both centres causes the occurrence of the phenomena of light or colour or visual hallucinations

in the entire field of vision. Cases of injury to the brain, where the sensations of light and space are quite intact, and where the colour sense alone is abolished, seem to indicate that the colour sense centre must be specially localised in the visual centre (Samelsohn, Steffan). After injury of certain parts, especially of the lower parietal lobe, "psychical blindness" may occur. A special form of this condition is known as "word-blindness" or *alexia* (*Cocitas verbalis*), which consists in this, that the patient is no longer able to recognise ordinary written or printed characters.

Charcot records an interesting case of psychical blindness. After a violent paroxysm of rage, an intelligent man suddenly lost the memory of visual impressions; all objects (persons, streets, houses) which were well known to him appeared to be quite strange, so that he did not even recognise himself in a mirror. Visual perceptions were entirely absent from his dreams.

Clinical observations on *hemipopia* (§ 344) show that the field of vision of each eye is divided into a larger outer and a smaller inner portion, separated from each other by a vertical line passing through the macula lutea. Each right or left half of both visual fields are related to *one* hemisphere; both left halves are projected upon the left occipital lobes, and both right upon the right occipital lobes. Thus, in binocular vision every picture (when not too small) must be seen in two halves; the left half by the left, the right half by the right hemisphere (Wernicke).

As a result of pathological stimulation of the visual centre, especially in the insane, visual spectres may be produced. Pick observed a case where the hallucinations were confined to the right eye.

2. The psycho-acoustic centre lies on both sides (crossed) in the temporo-sphenoidal lobes; when it is completely removed deafness results, while partial (left side) injury causes psychical deafness. Amongst the phenomena caused by partial injury is *surditas verbalis*, (*word-deafness*) which may occur alone, or in conjunction with *cocitas verbalis*. Wernicke found in all cases of *word-deafness*, softening of the first left temporo-sphenoidal convolution. In left-handed persons, the centre lies, perhaps, in the right temporo-sphenoidal lobes (Westphal).

Clinical.—We may refer the *cocitas* and *surditas verbalis* (Kussmaul) to the aphataxic group of diseases, in so far as they resemble the amnesic form. A person word-blind or word-deaf resembles one who in early youth has learned a foreign tongue, which he has completely forgotten at a later period. He hears, or reads the words and written characters; he can even repeat or write the words, but he has completely lost the significance of the signs. While an amnesic aphasic person has only lost the key to open his vocal treasure, in a person who is word-blind or word-deaf even this is gone. From a case of recovery it is known that to the patient the word sounds like a confused noise. Huguenin found atrophy of the temporo-sphenoidal lobes after long-continued deafness.

3. **Gustatory and Olfactory Centre.**—In the uncinate gyrus (on the *inner* side of the temporo-sphenoidal lobe, especially on the inner side of that marked U in Fig. 362), Ferrier locates the joint centre for smell and taste. These two centres do not seem to be distinct locally from each other.

4. **Tactile Areas.**—According to Tripier, Exner, Petrina, and others, all the *tactile* cerebral fields from different parts of the body coincide with the motor cortical centres for these parts.

Occasionally, in epileptics, strong stimulation of the sensory centres, as expressed in the excessive subjective sensations, accompanies the spasmodic attacks (compare § 393, 12).

Such epileptiform hallucinations, however, occur without spasms, and are accompanied only by disturbances of consciousness of very short duration (Berger).

Course of the Psycho-Sensory Paths.—The nerve-fibres, which conduct impulses from the sensory organs to the psycho-sensorial cortical centres,

pass through the *posterior part of the internal capsule* between the optic thalamus and the lenticular nucleus (Fig. 365). Hence, section of this part of the internal capsule causes hemianæsthesia of the opposite half of the body (Charcot, Veyssière, Carville, Duret, Raymond, M. Rosenthal). In such a case, sensory functions are abolished—only the viscera retaining their sensibility. There may also be loss of hearing (Veller, Donkin), smell and taste, and hemiopia (Bechterew).

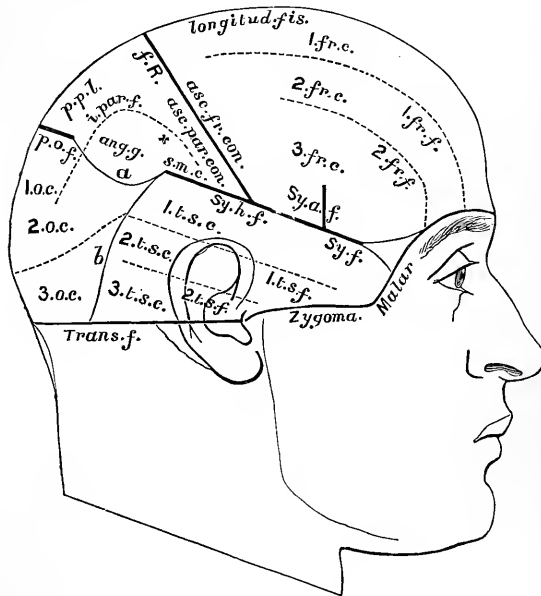

Fig. 363.

Relation of the fissures and convolutions to the surface of the scalp— + most prominent part of the parietal eminence; *a*, convex line bounding parietal lobe below; *b*, convex line bounding the temporo-sphenoidal lobe behind (R. W. Reid).

In cases where there is more or less injury or degeneration of these paths, there is a corresponding greater or less pronounced loss of the pressure and temperature sense, of the cutaneous and muscular sensibility, of taste, smell, and hearing. The eye is rarely quite blind, but the sharpness of vision is interfered with, the field of vision is narrowed, while the colour sense may be partially or completely lost. The eye on the same side may suffer to a slight extent.

V. Numerous cases of injury of the **anterior frontal region**, without interference with motor or sensory functions, have been collected by Charcot, Pitres, Ferrier, and others. On the other hand, enfeeblement of the intelligence and idiocy are often observed in acquired or congenital defects of the prefrontal region. In highly intellectual men, Rüdinger found in addition a considerable development of the temporo-sphenoidal lobe. According to Flechsig, there is no doubt that the frontal lobes and the temporo-occipital zone are related to intellectual processes, more especially the "higher" of these.

Topography of the Brain.—The relations of the chief fissures and convolutions of the brain to the surface of the skull are given in Fig. 360, the brain being represented after Ecker. [Turner and others have given minute directions for finding the position of the different convolutions by reference to the sutures and other prominent parts of the skull. The foregoing diagram (Fig. 363) by R. W. Reid, shows the relation of the convolutions to certain fixed lines.]

379. The Basal Ganglia—The Mid Brain.

The **corpus striatum** and **lenticular nucleus** (Fig. 365) in their development are co-ordinate with the development of the cortex cerebri. **Electrical stimulation** of these ganglia causes general muscular contractions in the opposite half of the body. The same result is obtained, as if all the motor cortical centres were stimulated simultaneously.

Gliky did not observe movements on stimulating the corpus striatum in rabbits; it would seem that in these animals the motor paths do not traverse these ganglia, but merely pass alongside of them.

Destruction of the lenticular nucleus, or of the corpus striatum, always causes loss of voluntary movements on the opposite half of the body (Meynert), with or without retention of sensibility. Destruction of the white fibres, between the corpus striatum and the motor cortical centres, has the same result as destruction of these centres themselves (Carville and Duret). The corpus striatum is quite insensible to painful stimulation (Longet).

Pathological.—In man, a lesion, not too small, destroying the anterior part of the corpus striatum, is followed by permanent paralysis of the opposite side, provided the internal capsule is injured, but the paralysis gradually disappears if the lenticular and caudate nucleus only are affected (compare § 365). Sometimes there is dilatation of the blood-vessels in consequence of vaso-motor paralysis (§ 377), if the posterior part is injured (Nothnagel); redness and a slightly increased temperature of the paralysed extremities, at least for a certain time; swelling or œdema of the extremities; sweating; anomalies of the pulse, detectable by the sphygmograph; decubitus acutus on the paralysed side; abnormalities of the nails, hair, skin; acute inflammations of joints, especially of the shoulder. Later, contracture or permanent contraction of the paralysed muscles takes place (Huguenin, Char-

cot). In some cases, there is cutaneous anæsthesia, and occasionally, enfeeblement of the sense-organs of the paralysed side; and both when the posterior section of the internal capsule is affected. Usually, however, *hemiplegia* and *hemianæsthesia* occur together.

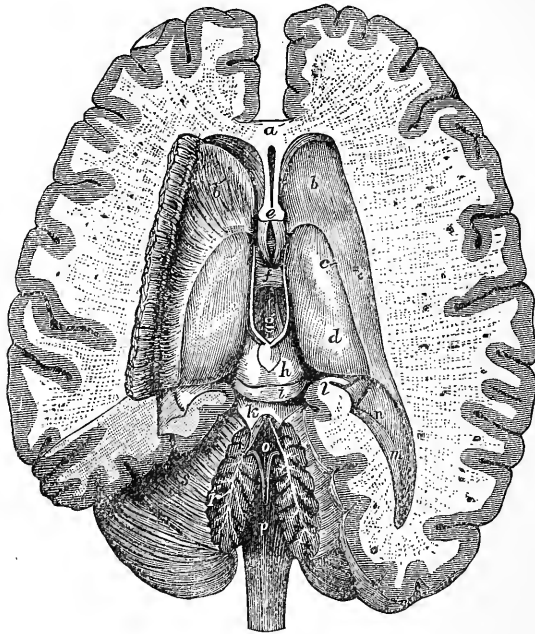

Fig. 364.

Dissection of the brain from above, showing the lateral, third, and fourth ventricles, with the basal ganglia, and surrounding parts—*a*, knee of the corpus callosum; *b*, anterior part of the right corpus striatum; *b'*, grey matter dissected off to show white fibres; *c*, points to tænia semicircularis; *d*, optic thalamus; *e*, anterior pillars of fornix, with fifth ventricle in front of them, between the two laminae of the septum lucidum; *f*, middle or soft commissure; *g*, third ventricle; *h*, *i*, corpora quadrigemina; *k*, superior cerebellar peduncle; *l*, hippocampus major; *m*, posterior cornu of lateral ventricle; *n*, eminentia collateralis; *o*, fourth ventricle; *p*, medulla oblongata; *s*, cerebellum, with *r*, arbor vitæ.

Optic Thalamus.—Ferrier did not observe any movements to occur on stimulating the optic thalami with electricity. As the optic thalamus is one of the parts connected with the origin of the optic nerve, and is also connected by fibres with the cortex cerebri, it is probably related to the sense of sight. Injury to the posterior third in man results in disturbance of vision (Nothnagel). Ferrier surmises that the sensory fibres pass through the optic thalami on their way to the cortex, so that when they are destroyed, insensibility of the opposite

half of the body is produced. Removal of the optic thalamus, or destruction of the part in the neighbourhood of the inspiratory centre in the wall of the third ventricle, influences the co-ordinated movements in the rabbit (Christiani).

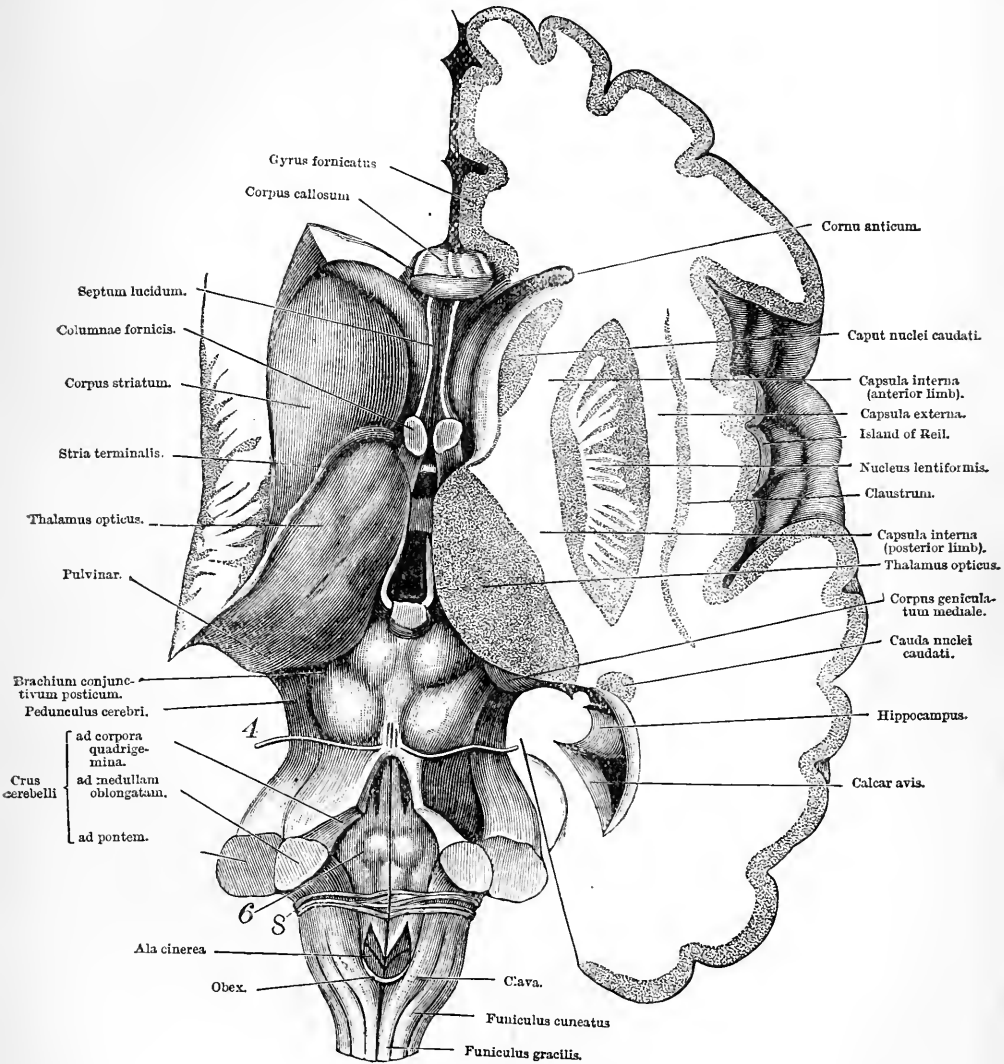

Fig. 365.

Human brain, with the hemispheres removed by a horizontal incision on the right side—4, trochlear; 8, acoustic nerve; 6, origin of the abducens.

We know very little definitely as to the functions of these organs. After injury to one thalamus, there has been observed enfeeblement or paralysis of the muscles

of the opposite side, together with *mouvements de manège*; and sometimes hemianæsthesia of the opposite side, with or without affections of the motor spheres, have been recorded.

Extirpation of certain cortical areas (rabbit) is followed by atrophy of certain parts of the thalamus (v. Monakow).

[**Internal Capsule.**—In connection with the functions of the basal ganglia, it is most important to remember their relation to the internal capsule. The corpus striatum consists of an intra-ventricular part, the *caudate nucleus*; and an extra-ventricular part, the *lenticular nucleus*. The lenticular nucleus consists of three parts (Fig. 366, 1, 2, 3) with white matter between them, the *striae medullares*. The anterior limb of the internal capsule sweeps between the caudate and lenticular nucleus, while the posterior segment lies between the optic thalamus and the lenticular nucleus (Fig. 366). External to the 1st division of the lenticular nucleus is the *external capsule* (Figs. 365 and 366), whose function is unknown. External to this is the claustrum (Figs. 365 and 366), whose function is also unknown. It is evident that

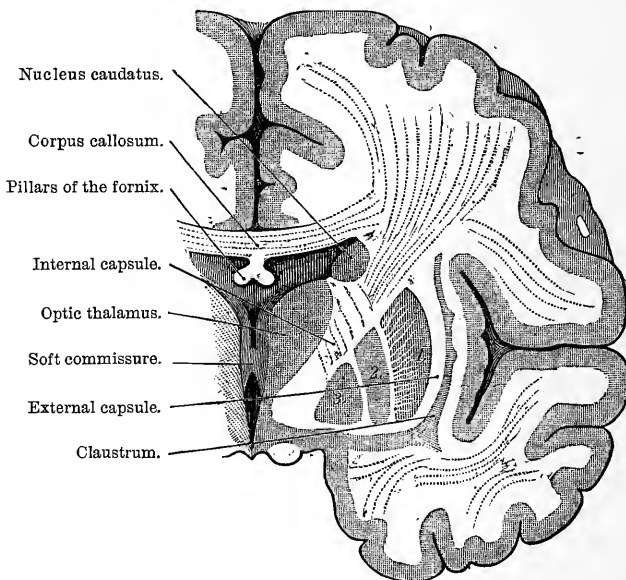

Fig. 366.

Frontal section through the right cerebral hemisphere in front of the soft commissure—Posterior surface of the section, $\frac{2}{3}$ (Gegenbaur).

hæmorrhage into or about the basal ganglia is apt to involve the fibres of the internal capsule. The fibres of the anterior two-thirds conduct motor impulses, and the posterior third sensory impulses.]

Pedunculi Cerebri.—Injury to one cerebral peduncle causes, in the first place, violent pain and spasm of the opposite side, while the blood-vessels on that side contract and the salivary glands secrete. These phenomena of irritation are followed by paralytic symptoms of the *opposite* side, viz., anæsthesia (§ 365) and paresis, or incomplete voluntary control over the muscles, as well as paralysis of the vaso-motor nerves. In affections of the cerebral peduncle in man, we must remember the relation of the oculomotorius to it, as the latter is often paralysed on the *same* side (Nothnagel).

The *middle* third of the crista of the cerebral peduncle includes the direct pyramidal tracts (§§ 365, 378). The fibres of the *inner* third connect the frontal lobes through the superior cerebellar peduncles with the cerebellum. In the *outer* third are fibres which connect the pons with the temporal and occipital cerebral lobes (Flechsigs). The fibres which pass from the tegmentum into the corona radiata conduct sensory impulses (Flechsigs).

Pons Varolii.—Stimulation or section of the pons causes pain and spasms; after the section there may be sensory, motor, and vaso-motor paralysis, together with forced movements. For diagnostic purposes in man, it is important to observe if alternate hemiplegia (p. 870) be present (Nothnagel).

The Corpora Quadrigemina.—Destruction of these bodies *on one side* in mammals, or their homologues, the optic lobes in birds, amphibians, and fishes, causes actual *blindness*, which may be on the same or the opposite side, according to the relation of the fibres crossing at the optic chiasma (§ 344). *Total* destruction causes blindness of both eyes. At the same time, the reflex contraction of the pupil, due to stimulation of the retina with light, no longer takes place (Flourens), where the optic is the afferent, and the oculomotorius the efferent nerve (§ 345). If the cerebral hemispheres alone be removed, the pupil still contracts to light, as well as after mechanical stimulation of the optic nerve (H. Mayo).

According to Bechterew, the fibres of one optic tract pass through the anterior brachium (Fig. 366) into the anterior pair (nates) of the corpora quadrigemina; while those fibres which cross in the chiasma (Fig. 318) pass into the posterior pair (testes). According to this arrangement we have partial blindness, according as one or other pair of these bodies is destroyed.

Destruction of the corpora quadrigemina interferes with the complete harmony of the motor acts; disturbance of equilibrium and inco-ordination of movements occur (Serres). In *frogs*, Goltz observed not only awkward, clumsy movements, but, at the same time, the animals have to a large extent lost the power of completely balancing the body (p. 905). A similar result was observed in pigeons (M'Kendrick) and rabbits (Ferrier). Extirpation of the eyeball is followed by atrophy of the opposite anterior corpus quadrigeminum.

Stimulation of the Corpora Quadrigemina.—The corpora quadrigemina react to electrical, chemical, and mechanical stimuli. The results of stimulation are very variously stated. According to some observers, there is dilatation of the pupil on the same side; according to Ferrier, it may be the pupil on the opposite or on the same side. The stimulation may be conducted from the corpora quadrigemina to the medulla oblongata, and to the origin of the sympathetic, for, after section of the sympathetic nerve in the neck, dilatation of the pupil no longer takes place (Knoll). According to Knoll, the contraction of the pupil observed by the older experimenters, occurs only when the adjoining optic tract is stimulated. Stimulation of the right anterior corpus quadrigeminum causes deviation of *both* eyes to the left (and conversely); on continuing the stimulation, the head is turned to this side. On dividing the corpora quadrigemina by a vertical median incision, stimulation of one side causes the result to take place only on one side (Adamük). Ferrier observed signs of pain on stimulating these organs in mammals. Carville and Duret conclude from their experiments, that these organs are centres for the extensor movements of the trunk. Ferrier found on stimulating one optic lobe in a pigeon, dilatation of the opposite pupil, turning of the head towards the other side and backwards; movement of the opposite wing and leg; strong stimulation caused flapping movements of both wings. Danilewsky, Ferrier, and Lauder Brunton observed a rise of the blood-pressure and slowing of the heart-beat, together with deeper inspiration and expiration. According to Valentin and Budge, stimulation also causes movement of the intestines and bladder, perhaps excited secondarily by the action of the vaso-motor nerves.

Bechterew ascribes all the phenomena, except those of vision itself, which accompany injury or stimulation of these bodies, to affections of deeper seated parts. He asserts that the corpora quadrigemina contain neither the centre for the movements of the pupils nor that for the combined movements of the eyeballs; not even the centre for maintaining the equilibrium of the body. Stimulation of these bodies causes the animals to perform marked movements. As reflex phenomena, nystagmus, forced movements and unsteadiness of the gait only occur, however, when the deeper parts are injured.

Pathological.—Lesions of the anterior pair in man, according to the extent of the lesion, cause disturbance of vision, failure of the pupil to contract to light, and even blindness; there may be paralysis of the oculomotorii on both sides. Disease of the posterior pair may be associated with disturbances of co-ordination (Nothnagel).

Forced Movements.—It is evident from what has been said regarding the importance of the corpora quadrigemina for the harmonious execution of movements, that *unilateral* injury of such parts as are connected to them by conducting channels, must give rise to peculiar unilateral disturbance of the equilibrium, causing variations from the symmetrical movements of both sides of the body. These movements are called *forced movements*. To this class belong the *mouvement de manège*, where the animal, instead of moving in a straight line, runs round in a circle; *index movements*, where the anterior part of the body is moved round the posterior part which remains in its place, just like the movements of an index round its axis; and *rolling* movements, when the animal rolls on its long axis. All these forms of movement may pass into each other, and they are, in fact, merely different varieties of the same kind of movement. The

parts of the nervous system, whose injury produces these movements are the corpus striatum, optic thalamus, cerebral peduncle, pons, pedunculus cerebelli ad pontem, and certain parts of the medulla oblongata. Eulenburg observed index movements in the rabbit after injury to the surface of the brain, and Bechterew observed the same in dogs. Forced movements, together with nystagmus and rotation of the eyeballs, are caused by injury to the olives (Bechterew).

The statements of observers vary as to the direction and kind of movement produced by injuring individual parts. The following observations have been made: Section of the *anterior* part of the pons and of the crura cerebelli causes index, or it may be, rolling movements towards the other side; section of the *posterior* part of the same regions causes rolling movements towards the *same* side, while the same result is caused by a deeper puncture into the tuberculum acusticum, or into the restiform body. Section of one cerebral peduncle causes movements de manège, while the body is curved with the convexity towards the same side. The nearer to the pons the section is made, the smaller is the circle described; ultimately index movements occur. Injury to one optic thalamus produces results similar to puncture of the anterior part of the cerebral peduncle, because the latter is injured along with it at the same time. Injury to the anterior part of one optic thalamus causes the opposite kind of forced movement, viz., with the concavity of the body towards the injured side. Injury to the spinal portion of the medulla oblongata is followed by bending of the head and vertebral column, with the convexity towards the injured side, along with movements in a circle. When the anterior end of the calamus and the part above it are injured, the movements are towards the sound side.

Strabismus and Nystagmus.—Amongst the forced movements may be reckoned deviation of the eyeballs, strabismus or squinting, and involuntary oscillation of the eyeballs, constituting *nystagmus*. The latter condition occurs after superficial lesions of the restiform body, as well as of the floor of the fourth ventricle. A unilateral deep transverse injury, from the apex of the calamus upwards as far as the tuberculum acusticum, causes the eye of the same side to squint downwards and forwards, that of the other side backwards and upwards. Section of both sides causes this condition to disappear (Schwahn). Hence, Eckhard assumes that the medulla oblongata is the seat of an apparatus controlling the movements of the eyes (Eckhard).

In pathological degeneration of the olivary body of the medulla oblongata in man, Meschede observed intense rotatory movements towards the *same* side.

Theory.—In order to explain the occurrence of forced movements, it is suggested that there is unilateral incomplete paralysis (Lafarque), so that the animal,

in its efforts to move onwards, leaves the paralytic side slightly behind the other, and, hence, there is a variation from the symmetry of the movements. Brown-Séquard regards the matter in exactly an opposite light, viz., as due to stimulation from injury causing an excessive activity of one-half of the body. Henle ascribes the movements to *vertigo*, or a feeling of giddiness caused by the injury.

In all operations on the central nervous system, where the equilibrium is deeply affected, there is a considerable increase in the number and depth of the respirations (Landois).

Other Functions.—Some observers noticed variations of the blood-pressure and a change in the number of heart-beats after stimulation of the cortex cerebri, *e.g.*, after electrical stimulation of the motor areas for the extremities (Bochefontaine). Balogh observed acceleration of the pulse on stimulating several points on the cortex cerebri of a dog, and from one point slowing of the pulse. Eckhard stimulated the surface of the brain in rabbits, and, as a rule, he observed that as long as single crossed movements occurred in the anterior extremities, there was no effect upon the heart, but that the heart became affected as soon as other movements occurred. This consists in slow, strong pulse-beats, with occasional weaker beats, while, at the same time, the blood-pressure is slightly increased (Bochefontaine). If the vagi be divided beforehand, the effect upon the pulse disappears, while the increase of the blood-pressure remains. That psychical processes affect the action of the heart was known to Homer and Chrysipp. Bochefontaine and Lépine, on stimulating several points, especially in the neighbourhood of the sulcus cruciatus in the dog, observed increased secretion of saliva (p. 290), slowing of the movements of the stomach, peristalsis of the intestine, contraction of the spleen, of the uterus, of the bladder, and increased respirations. Bufalini, on stimulating those parts of the cortex which cause movements of the jaw, observed the secretion of gastric juice with increase of the temperature of the stomach.

Schiff, Brown-Séquard, Ebstein, Klosterhalfen, and others, have observed that injury to the pons, corpus striatum, thalamus, cerebral peduncle, and medulla oblongata often causes hyperæmia and hæmorrhage into the lung (according to Brown-Séquard, especially after injury to one side of the pons, which affects the opposite lung), under the pleura, in the stomach, intestine, and kidneys. Gastric hæmorrhage is common after injury to the pons just where the cerebral peduncles join it. Similar phenomena have been observed in man after apoplexy or cerebral hæmorrhage.

Specially interesting is the cerebral *unilateral decubitus acutus* described by Charcot, which always occurs on the paralysed side of the body, *i.e.*, on the side opposite to the cerebral injury. It begins on the 2nd or 3rd day, rapidly causes enormous destruction and sloughing of the tissues on the back and lower extremities, and death soon takes place. The decubitus, which occurs after spinal injuries, usually begins in the middle line of the buttocks, and extends symmetrically on *both* sides. In cases of unilateral injury to the spinal cord, the decubitus occurs on the *corresponding* side of the sacral region (p. 783).

[**Corpus Callosum.**—It is usually stated that the corpus callosum connects the convolutions of one side of the brain with those on the other. D. J. Hamilton, however, states that it is not an interhemispheric commissure, but is due to cortical fibres coming from the cortex cerebri to be connected with the basal ganglia of the opposite side. On this view, the “corona radiata,” as usually understood, consists only of the fibres which pass from the cerebral peduncle directly up to the cortex on the same side, and are contained in the posterior division and knee of the internal capsule. They correspond to the motor pyramidal tracts. Hamilton maintains that all the other fibres of the internal capsule pass into the *crossed callosal* tract, and instead of running directly up to the cortex on the same side, cross in the corpus callosum to the cortex of the opposite side.]

380. Structure and Functions of the Cerebellum.

[**Structure.**—On examining a vertical section of a cerebellar leaflet, we observe the following microscopic appearances:—Externally, is the pia matter with its blood-vessels (Fig. 367, *a*) which penetrate into the outer grey layer. The grey matter consists of, *b*, a broad grey layer largely composed of branched fibrils, and internal to it is, *d*, the “granular,” nuclear, or rust-coloured layer.

On the boundary line between these two is the layer of Purkinje’s cells, *c*. The cells of Purkinje form a single layer of large multipolar flask-shaped nerve-cells, which have been compared to the branched antlers of a stag. From their outer surface is given off a process which rapidly divides, and gives rise to a large number of smaller processes running outwards in the outer grey layer. Some of these processes form part of the ground plexus of fibrils in this layer; while others, according to Sankey, terminate in connection with the small corpuscles in the outer layer; an unbranched axial cylinder process is sent inwards to the granular layers, where it becomes continuous with a nerve-fibre. The outer grey layer, besides containing the branches of Purkinje’s cells with their matrix, contains sustentacular fibres and granular corpuscles, and some small, branched cells, probably nerve-cells. The granular layer consists of corpuscles embedded in a matrix which is fibrillated in part.

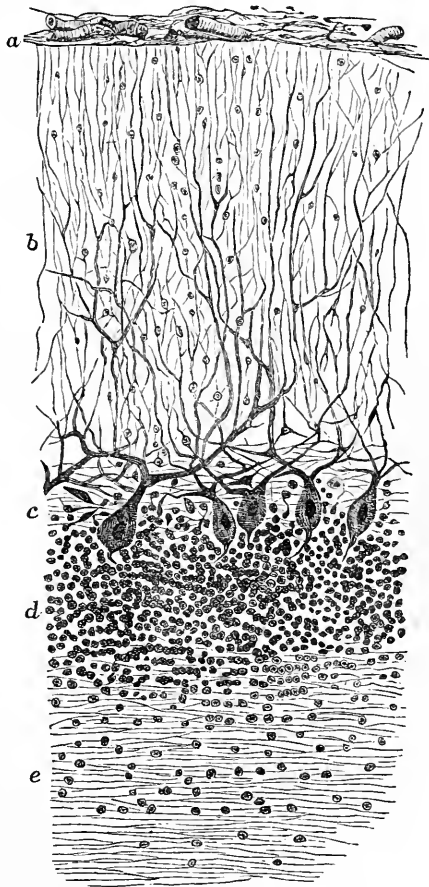

Fig. 367.

Vertical section of the cerebellum—*a*, pia mater; *b*, external layer; *c*, layer of Purkinje’s cells; *d*, inner layer; *e*, medullary white matter.

The granular layer consists of corpuscles embedded in a matrix which is fibrillated in part. Each granule or nucleus is surrounded by a

small quantity of protoplasm. Their exact relations and connections are unknown. Internal to *d* is *e*, the central white matter.]

Function.—Injuries of the cerebellum cause disturbances of the equilibrium of the body. Most probably, the cerebellum is a great and important central organ for the finer co-ordination and integration of movements. The fact that it is connected with all the columns of the spinal cord, with the central ganglia of the corpora quadrigemina and cerebrum, renders this very probable. The direct cerebellar tracts conduct sensory impressions to the cerebellum, and thus indicate the posture of the trunk. The cerebellum may affect the motor nerves of the cord through fibres which pass downward in the lateral columns of the cord, from the restiform bodies (Flechsig). Injury of the cerebellum produces neither disturbance of the psychical activities, nor does it interfere with the will or consciousness. Injuries to the cerebellum itself do not give rise to pain.

According to Schiff, the cerebellum does not actually regulate the co-ordination of movements. According to him, there is a mechanism on both sides of the middle line, which increases all the complicated muscular movements; not only those for powerful contractions, but also the peculiar fine movements which fix the limbs and joints. Luciani asserts that destruction of the cerebellum produces a condition of incomplete tonus, there being a want of energy to control the voluntary muscles. Each half of the organ acts on both halves of the body.

Removal of the Cerebellum.—The results produced by injury to or removal of the cerebellum have been admirably described by Flourens. On removing the most superficial layers in a *pigeon*, the animal merely showed signs of weakness and interference with the uniformity of its movements. On removing more of cerebellum, the animal became greatly excited, and made violent, irregular movements, which did not partake of the character of convulsions. The sensorium was unaffected, while vision and hearing were intact. Co-ordinated movements, such as walking, flying, springing, and turning, could be executed but imperfectly. After removal of the deepest layers, the power of executing the above-named movements was completely abolished. On placing the pigeon on its back, it could not get on its legs; at the same time, it made continually the greatest exertions in its movements, but these were always inco-ordinated, and, therefore, without any satisfactory result. The will, intelligence, and perception remained intact; the animal could see and hear, sought to avoid obstacles placed in its way; it gradually exhausted itself in fruitless efforts to get on its legs, and ultimately remained in its abnormal position quite exhausted. Flourens concluded from these experiments, that the cerebellum is the centre for co-ordinating voluntary movements. Lussana and Morganti regard the cerebellum as the seat of the muscular sense.

[**Extirpation in Mammals.**—The dangers attending this operation are so great that but few animals survive. Luciani, however, by using antiseptic and other precautions, has been able to do this so that complete cicatrisation was obtained, the animal (young bitch) being restored to health for a few months. The cerebellum alone was removed, but not its peduncles. As in all other similar operations, we must distinguish sharply the phenomena manifested during recovery from those after complete recovery. During the *first period* of six weeks, from the time of the operation until complete recovery, the symptoms are those of injury and irritation of the divided peduncles, along with those resulting from the removal of the organ. They are chronic contractions of the muscles of the fore limb, neck, and back, passing into tonic contractions, when the animal attempts to move, and also weakness of the hind legs, so that all the normal voluntary movements are interfered with, *i.e.*, inco-ordinated, although these symptoms may be explained by the injury to adjoining parts. There was no sensory disturbance or loss of the muscular sense, although closing the eyes rendered standing impossible. As recovery takes place, these symptoms disappear, and the animal enters on the *second period*, where the symptoms depending on the actual loss of the organ are pronounced. The contracture and pseudo-paralytic weakness disappear, while there are alterations in the tone of the individual muscles, producing a sort of "cerebellar ataxy." The dog could swim in quite a normal manner, its power of equilibration was not interfered with, but acts requiring a greater development of muscular energy could not be properly executed. In fishes also the removal of the cerebellum does not affect their power of locomotion (Bandelot). This period lasted 4-5 months. After this time its health gave way, there was otitis, conjunctivitis, articular, and cutaneous inflammations, while a peculiar form of marasmus set in, the animal dying after eight months.]

Duration of the Phenomena.—After superficial lesions, or after a deep incision, the disturbances of co-ordination soon pass away (Flourens). If the injury affects the lowest third of the cerebellum, the motor disturbances remain permanently. Symmetrical lesions do not disturb co-ordination (Schiff). After removing the greater portion of the cerebellum in birds, Weir-Mitchell has observed that the original disturbances gradually disappear; and, *after months*, only slight weakness and a condition of rapid fatigue remain.

In the *dog*, superficial injuries of the vermiform process, or of one half of the organ, produce merely temporary disturbances; while deep injuries to the vermiform process, or removal of one hemisphere and a part of the vermiform process, cause permanent rigidity of the legs and shaking of the head; if the worm and both halves are destroyed, there follows permanent, pronounced disturbance of co-ordination (*v. Mering*). According to Baginsky, destruction of a large part of the vermiform process alone, causes in mammals permanent disturbance of co-ordination. Ferrier found that a vertical section of the cerebellum in *monkeys* produced only inconsiderable disturbances of equilibrium; after injury of the anterior part of the middle lobe, the animal often tumbles forward, while, when the posterior part is injured, it falls backward. After injury of the lateral lobe, the animal is drawn towards the affected side (Schiff, Vulpian, Ferrier, Hitzig). If the middle commissure be injured, the animal rolls violently on its long axis towards the injured side (Magendie). Paralysis never occurs after injuries of the cerebellum, nor is there ever disturbance of sensation or of the sense of touch. Luciani found that marasmus ultimately set in in animals with the cerebellum extirpated.

In *frogs* an important organ concerned with motion lies at the junction of the

oblongata with the cerebellum (Eckhard). After it is removed, the animal can no longer execute co-ordinated jumping movements, nor can it crawl (Goltz).

After injuries of the cerebellum, involuntary oscillations of the eyeballs, or nystagmus (Sancerotte, 1769), as well as squinting (Magendie, Hertwig), have been observed; while Ferrier observed movements of the eyeballs after electrical stimulation. According to Curschmann, Eckhard, and Schwahn, this occurs only when the medulla oblongata is involved (§ 379).

Effects of Electricity and Vertigo.—If an electrical current be passed through the head, by placing the electrodes in the mastoid fossæ behind both ears, with the + pole behind the right and the — pole behind the left ear, then on closing the current there is severe *vertigo*, and the head and body lean to the + pole, while the objects around seem to be displaced to the left. If the eyes be closed while the current is passing, the movements appear to be transferred to the person himself, so that he has a feeling of rotation to the left (Purkinje). At the moment the head leans towards the anode, the eyes turn in that direction, and often exhibit nystagmus. The electrical current probably stimulates the nerves of the ampullæ, as we know that affections of these bodies cause vertigo (§ 350). The cerebellum has no relation to the sexual activities, as was maintained by Gall. The contractions of the uterus observed by Valentin, Budge, and Spiegelberg, after stimulation of the cerebellum, are as yet unexplained.

Pathological.—Lesions of *one* hemisphere may give rise to no symptoms, but if the middle lobe is involved, there is inco-ordination of movement, especially a tendency to fall, unsteady gait, and pronounced vertigo. Irritative lesions of the *crura cerebelli ad pontem* cause complete gyrating movements of the body around its axis, together with rotation of the eyes (Nonat) and head (Nothnagel).

381. Protective Apparatus of the Brain.

The Membranes.—The *dura mater cerebri* is intimately united to the periosteum of the cavity of the skull, while the *spinal dura mater* forms around the spinal cord a freely suspended, long sac, fixed only on its anterior surface. It

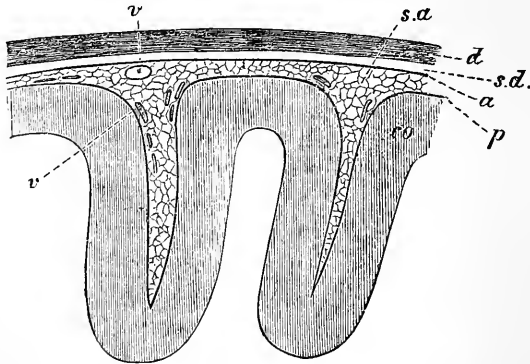

Fig. 368.

Vertical section of the cortex cerebri and its membranes— $\times 2\frac{1}{2}$, *co*, cortex cerebri; *p*, intima piæ dipping into the sulci; *a*, arachnoid, connected with *p* by means of the loose sub-arachnoid trabeculae in the sub-arachnoid space, *sa*; *v*, *v*, blood-vessels; *d*, *d*, dura; and *s.d.*, sub-dural space.

is a fibrous membrane, consisting of firm bundles of connective-tissue, intermixed with numerous elastic fibres, and provided with flattened connective-tissue corpuscles and Waldeyer's plasma cells. The smooth inner surface is covered with a layer of endothelium. It is but slightly supplied with blood-vessels, although they are more numerous in the outer layers; the lymphatics are numerous, while nerves whose terminations are unknown, give to the dura its exquisite sensibility to painful operations on it. Pacinian corpuscles have been found in the dura over the temporal bone. The lymphatic *subdural space* (Key and Retzius) lies between the dura and the arachnoid, and between the pia and arachnoid, is the *subarachnoid space* (Fig. 368). These two spaces do not communicate directly. The delicate arachnoid, thin and partially perforated, poor in blood-vessels, and without nerves, is covered on both surfaces with squamous endothelium. Only on the spinal cord is it separated from the pia, so that between both lies the lymphatic subarachnoid space; over the brain, the two membranes are for the most part united together, except the parts bridging over the sulci between adjacent convolutions. The arachnoid passes from convolution to convolution without dipping into the sulci, while the pia dips into each sulcus. The ventricles of the brain communicate freely with the lymphatic *subarachnoid space*, but not with the *subdural space* (Waldeyer and Fischer). The pia consists of delicate bundles of connective-tissue without any admixture of elastic fibres; it is richly supplied with blood-vessels and lymphatics, and carries nerves which accompany the blood-vessels into the substance of the brain (Kölliker). The lymphatics open into the subarachnoid space (p. 406). Regarding the *cerebrospinal fluid* see p. 411.

The **Pacchionian bodies**, or granulations, are connective-tissue villi, which serve for the outflow of lymph from the subdural and subarachnoid spaces into the sinuses of the dura mater, especially the longitudinal sinus. The subarachnoid space also communicates with the spaces in the spongy bone of the skull, and with the veins of the skull and surface of the face (Kollmann). The subdural space also communicates with the lymphatic spaces in the dura, while the latter communicate directly with the veins of the dura. Both the subdural and subarachnoid lymphatic spaces communicate with the lymphatics of the nasal mucous membrane. The space outside the dura of the spinal cord is called the *epidural space*, and may be regarded as lymphatic in its nature; the pleural and peritoneal cavities may be filled from it; but it does not communicate with the cavity of the skull (Waldeyer and Fischer). The plexuses of blood-vessels are surrounded by undeveloped connective-tissue. The *telæ choroideæ* in the new-born are still covered with ciliated epithelium.

The Movements of the Brain.—The pulsations of the large basal cerebral vessels communicate their *pulsatile* movements (§ 79, 6) to the brain—the *respiratory* movements also affect it, so that the brain rises during expiration and sinks during inspiration. Lastly, there are slight alternating *vascular* elevations and depressions, occurring 2-6 times per minute, due to the periodic dilatation and contraction of the blood-vessels (p. 896). Psychological excitement influences these, and they are most regular during sleep (Burckhardt, Mays). The movements are best seen, especially where the membranes of the brain offer little resistance, *e.g.*, over the fontanelles in children, and where the membranes have been exposed by trephining. The presence of the cerebrospinal fluid is most important for the occurrence of these movements, as it propagates the pressure uniformly, so that every systolic and

expiratory dilatation of the blood-vessels is concentrated upon those parts of the cerebral membrane which do not offer any resistance (Donders). When the fluid escapes, the movements may almost disappear.

Mental excitement increases the pulsations of the brain. At the moment of awaking the amount of blood in the brain diminishes; sensory stimuli, applied during sleep, so that the sleeper does not awake, increase the amount of blood. As the arteries within the rigid skull-case change their volume with each pulse-beat, the veins (sinuses) exhibit at every beat a pulsatile variation in volume, the opposite of that occurring in the arteries (Mosso).

The Cerebral Blood-Vessels.—The blood-vessels of the pia, of course, are regulated by the vaso-motor nerves (§ 356, A, 3), and their calibre may also be influenced by the stimulation of more distant parts of the body (§ 347). Donders trephined the skull, so as to make a round hole, and filled it with a piece of glass, so that with a microscope he could observe changes in the calibre of the blood-vessels. Paralysis of the vaso-motor nerves and narcotics dilate the blood-vessels; they become greatly contracted at death (§ 373, I). The blood-vessels are dilated during cerebral activity (§ 100, A) as well as during sleep. Increased pressure within the skull causes great derangement of the cerebral activity; laboured respiration (§ 368, B), unconsciousness even to coma, and paralytic phenomena—all

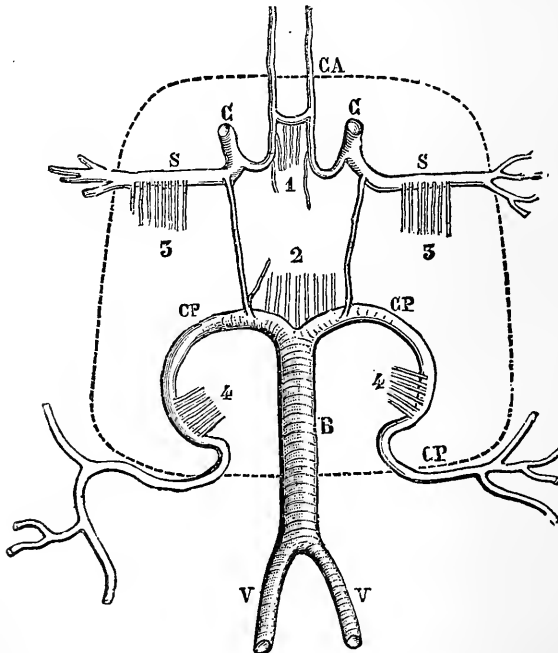

Fig. 369.

Arteries of the base of the brain, or circle of Willis (after Charcot)—CC, internal carotids; CA, anterior cerebral; SS, Sylvian arteries; VV, vertebrals; B, basilar; CP, posterior cerebrals; 1, 2, 3, 3, 4, 4, groups of nutrient arteries. The dotted line shows the limit of the ganglionic circle.

of which may, in part, be referable to disturbances of the circulation. If all the cranial arteries be ligatured suddenly, there is immediate loss of consciousness, together with strong stimulation of the medulla oblongata and its centres, and death takes place rapidly with convulsions (compare § 373).

By the *free anastomosis* which takes place at the base of the brain (Fig. 369), the individual parts of the brain are preserved from want of blood, when one or other blood-vessel is compressed or ligatured. Within the brain the arteries are distributed as "*terminal*" arteries—*i.e.*, the terminal branches of any one artery end in their own area, and do not anastomose with those of adjoining areas (Cohnheim). On the other hand, the peripheral arteries (arteries of the corpus callosum, Sylvian fissure, and deep cerebral) which run externally on the brain, form free anastomoses (Tichomirow).

[The **nutrient** or **ganglionic arteries** for the central ganglia arise in groups from the circle of Willis, or from the first two centimetres of its trunks. The *antero-median* group (1) supplies the anterior part of the head of the caudate nucleus. The *postero-median* (2) supplies the internal surface of the optic thalami and the walls of the third ventricle. The *antero-lateral* groups (3, 3) from the Sylvian supply the corpora striata, and the anterior part of the optic thalamus. The *postero-lateral* (4, 4) supply a large part of the optic thalami (Charcot). A line drawn at a distance of two centimetres outside the circle of Willis encloses the *ganglionic circle*. The cerebral convolutions are supplied by the large

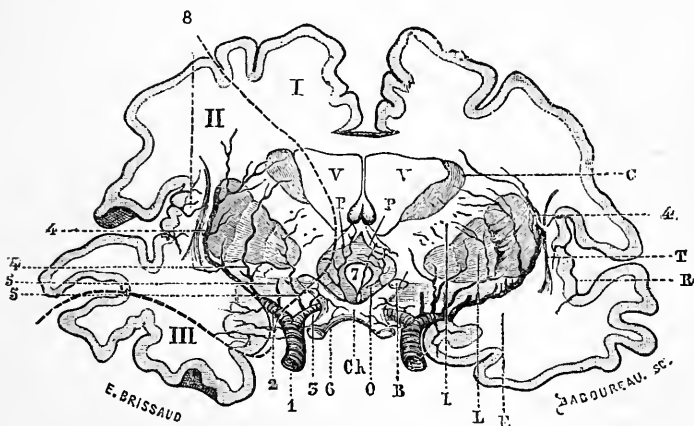

Fig. 370.

Tranverse section of the cerebrum behind the optic chiasma: Arteries of the corpus striatum—Ch, optic chiasma; B, section of optic tract; L, lenticular nucleus; I, internal capsule or foot of Reil's corona radiata; C, caudate nucleus; E, external capsule; T, claustrum; R, convolutions of the Island of Reil; V V, section of the lateral ventricles; P P, pillars of the fornix; O, grey substance of the third ventricle. Vascular areas—I, anterior cerebral artery; II, Sylvian artery; III, posterior cerebral artery. 1, Internal carotid; 2, Sylvian, 3, anterior cerebral artery; 4 4, lenticulo-striate arteries; 5 5, lenticular arteries.

branches of the circle of Willis. The *anterior cerebral* supplies the gyrus rectus, and the supra-orbital, the first and second frontal convolutions, the præcentral, and quadrate lobules (Fig. 370, I). The *posterior cerebral* goes to the region of the occipital lobe, while the *Sylvian* artery goes to the posterior part of the frontal lobe, and to all the parietal lobe, *i.e.*, chiefly to the motor areas (III). The

terminal branches of these ganglionic arteries do not anastomose with the cortical system. Fig. 370 shows the ganglionic arteries piercing the basal ganglia. Obviously when hæmorrhage of the lenticulo-striate artery (4, 4) occurs it will compress the lenticular nucleus, or tear it up, and may even injure the parts outside, such as the external capsule, claustrum (T), and Island of Reil (R), or those inside, *e.g.*, the internal capsule.]

If a person who has been in bed for a long time, and whose blood is small in amount, be suddenly lifted up into the erect position, cerebral anæmia is not unfrequently produced, owing to hydrostatic causes. At the same time there may be loss of consciousness and impairment of the senses. Liebermeister regards the *thyroid gland* as a collateral blood-reservoir which empties its blood towards the head during such changes of the position of the body. Perhaps this may explain the swelling of the thyroid, as a compensatory act, when the heart beats violently, and the brain is surcharged with blood (§ 103, III., and 371). Very violent muscular exertion, as well as marked activity of other organs, cause a very considerable fall of the blood-pressure in the carotid.

Pressure on the Brain.—The brain and the fluid surrounding it are constantly subjected to a certain mean *pressure*, which must ultimately depend upon the blood-pressure within the vascular system. The investigations of Naunyn and Schreiber on the *cerebral pressure* (or cerebro-spinal pressure) showed, that the pressure must be slightly less than the pressure within the carotid before the symptoms proper to pressure on the brain occur. These are—sudden attacks of headache, with vertigo, or it may be loss of consciousness, vomiting, slowing of the pulse, slow and shallow respiration, convulsions—while the pressure of the cerebro-spinal fluid is increased. The cause of these phenomena lies in the anæmia of the brain. If the pressure is moderate, the above-named symptoms may remain latent; nevertheless, disturbances of the nutrition of the brain occur, with consecutive phenomena, such as persistent slight headache, feeling of vertigo, muscular weakness, and disturbances of vision (owing to neuro-retinitis with choked disc). Increase of the blood-pressure diminishes the symptoms, while diminution of the blood-pressure causes more pronounced phenomena of cerebrospinal pressure.

In the dog, *pain* begins with a pressure of 70–80 mm. Hg. *Consciousness is abolished* when the pressure is higher, and at 80–100 mm. *spasms* take place. A pressure of 100–120 mm. causes *slowing of the pulse*, owing to stimulation of the *vagus* at its origin; the respirations are temporarily accelerated and then diminish. Long-continued severe compression always, sooner or later, ends fatally. The blood-pressure at first is increased, owing to reflex stimulation of the vaso-motor centre, from the pressure stimulating the sensory nerves; ultimately, the blood-pressure falls, and the pulse becomes very slow. Irregular variations in the blood-pressure point to a direct central stimulation of the vaso-motor centre by pressure.

The application of continued slowly-increasing pressure compresses the brain (Adamkiewicz).

382. Comparative—Historical.

Comparative.—Nerves are absent in the *protozoa*. Neuro-muscular cells (§ 296) occur in the *coelenterata*, in the hydroids and medusæ, and they are the first indications of a nervous apparatus. The umbrella of the medusa is covered with a plexus of nerve-fibrils, which, at various parts along its margin, is provided with small cellular thickenings corresponding to ganglia, and from these nerve-fibres proceed to the sense organs. Many of the *worms* possess a nervous ring in the cephalic portion, and in those provided with an intestine, a single or double nervous

cord, in the form of a ring, surrounds the pharynx. Branches (often two) pass from this into the elongated body, and usually these carry ganglia corresponding to each ring of the body of the animal. In the leech only one gangliated cord is present.

In the *echinodermata* a large nerve-ring surrounds the mouth, and from it large nerves proceed corresponding to the chief trunks of the water-vascular system. At the points where the nerves are given off, the nervous ring is provided with the so-called "ambulacral brains." The *arthropoda* are provided with a large cephalic ganglion placed above the pharynx, from which nerves pass to the sense organs. Another ganglion lies on the under surface of the pharynx, and is connected with the former by commissures. The pharynx is thus embraced by a gangliated ring, from whence proceed the abdominal gangliated double chain, along the ventral surface of the body, through the thorax and abdomen. Sometimes several ganglia unite to form a large compound ganglion, while in other cases each segment of the body contains its own ganglia. In the *mollusca* the œsophageal nervous ring is present, although the ganglionic masses vary much in position within it. A number of compound ganglia lie scattered in different parts of the body, and are united by nerves to the former. They represent the sympathetic system. In the *cephalopoda* the œsophageal ring has almost no commissure, and a part of the ganglionic matter is enclosed in a cartilaginous capsule, and is often spoken of as a "brain." Additional ganglia are found in the mantle, heart, and stomach. In *vertebrates* the nervous system invariably lies on the dorsal aspect of the body. In the amphioxus there is no separation into brain and spinal cord. (See § 374 and § 375.)

Historical.—Alkmaion (580 B.C.) placed the seat of consciousness in the brain, Galen (131-203 A.D.) regarded it as the seat of the impulses for voluntary movements. Aristotle (384 B.C.) ascribed the relatively largest brain to man; he stated that it was inexcitable to stimuli (insensible). One of the functions he ascribed to the brain was to cool the heat ascending from the heart. Herophilus (300 B.C.) gave the name calamus scriptorius; and he regarded the fourth ventricle as the most important organ for the maintenance of life. Even in Homer there are repeated references to the dangers of injuries of the neck. Aretæus and Cassius Felix (97 A.D.) were aware of the fact that lesion of one cerebral hemisphere caused paralysis on the opposite side of the body. Galen was acquainted with the path in the spinal cord connected with movement and sensation. Vesalius (1540) described the five ventricles of the brain. R. Colombo (1559) observed the movements of the brain, isochronous with the action of the heart. A more careful description of these movements was given by Riolan (1618). Coiter (1573) discovered that an animal can live after removal of its cerebrum. About the middle of the 17th century, Wepfer discovered the hæmorrhagic nature of apoplexy. Schneider (1660) estimated the weight of the brain in different animals. Mistichelli (1709) and Petit (1710) described the decussation of the fibres of the spinal cord below the pons. Gall discovered the partial origin of the optic nerve from the anterior pair of the corpora quadrigemina, and by dissecting the brain from below, he attempted to trace the course of the nerve-fibres to the convolutions (1810). Rolando described more accurately the form of the grey matter of the spinal cord. Carus (1814) discovered the central canal. The most compendious work on the brain was written by Burdach (1819-1826). The more recent observations are referred to in the text.

Physiology of the Sense Organs.

383. Introductory Observations.

Requisite Conditions.—The sense organs have the function of transferring to the sensorium impressions of the various phenomena of the external world; they are, in fact, the intermediate instruments of *sensory perceptions*. In order that this may occur, the following conditions must be fulfilled:—1. The sense organ, provided with its specific end-organ, must be anatomically perfect, and capable of acting physiologically. 2. A “specific” stimulus must be present, which under normal conditions acts upon the end organ. 3. The sense organ must be connected with the cerebrum by means of a nerve, and the conduction through this path must be uninterrupted. 4. During the act of stimulation, the psychical activity (attention) must be directed to the process, and then the *sensation* results, *e.g.*, of light or sound, through the sense organ. 5. Lastly, when by a psychical act, the sensation is referred to the external cause, then there is a conscious sensory perception. Often, however, this relation is completed as an unconscious conclusion, as it is essentially a deduction from previous experience.

Stimuli.—With regard to the stimuli which are applied to the sensory apparatus, we distinguish:—1. *Adequate* or *homologous* stimuli, *i.e.*, stimuli for whose action the sense organs are specially adapted, such as the rods and cones of the retina for the vibrations of the ether. Thus, each sense organ has a specific form of stimulus best adapted to act upon it. This is what Johannes Müller called the law of specific energy. 2. There are many other forms of stimuli (mechanical, thermal, chemical, electrical, internal somatic) which act upon the sense organs, producing the flash of light beheld when the eye is struck; singing in the ears when there is congestion of the head. These *heterologous* stimuli act upon the nervous elements of the sensory apparatus along their *entire* course, from the end-organ to the cortex cerebri. The homologous stimuli, on the other hand, act only on the end-organ, *i.e.*, light has no effect whatever upon the trunk of the exposed optic nerve.

Strength and Liminal Intensity.—Homologous stimuli act upon the sensory organs only within certain limits as to *strength*. Very feeble

stimuli at first produce no effect. That strength of stimulus which is just sufficient to cause the first trace of a sensation is called, by Fechner, the "*liminal intensity*" of the sensation. As the strength of the stimulus increases, so also do the sensations, but the sensations increase equally, when the strength of the stimulus increases in relative proportions. Thus, we have the same sensation of equal increase of light when, instead of 10 candles, 11, or, instead of 100 candles, 110 are lighted—the proportion of increase in both cases is equal to one-tenth. As the logarithm of the numbers increases in an equal degree, when the numbers increase in the same relative proportion, the law may be expressed thus: "The sensations do not increase with the absolute strength of the stimuli, but nearly as the logarithm of the strength of the stimulus." This is Fechner's "**psycho-physical law**," but its accuracy has recently been challenged by E. Hering. [It holds good only with regard to stimuli of medium strength.] If the specific stimulus be too intense, it gives rise to peculiar painful sensations, *e.g.*, a feeling of blindness or deafness, as the case may be. The sense organs respond to adequate stimuli, but only within certain *limits* of the stimulus, *e.g.*, the ear responds only to vibrating bodies emitting a certain range of vibrations per second; the retina responds only to the vibrations of the ether between red and violet, but not to the so-called heat vibrations or to the chemically active vibrations.

[Fechner's Law.—Expressed in another way, the result depends on (1) the strength of the stimulus, and (2) the degree of excitability. Supposing the latter to be constant, while the former is varied, it is found that if the stimulus be doubled, tripled, or quadrupled, the sensation increases only as the *logarithm of the stimulus*. Suppose the stimulus to be increased 10, 100, or 1000 times, then the sensation increases only as 1, 2, or 3. Just as there is a *lower limit of excitation*, *liminal intensity* (or *threshold*), so there is an upper limit or *maximum of excitation* or *height of sensibility* (Wundt), when any further increase produces no appreciable increase in the sensation. Thus we do not notice any difference between the central and peripheral portion of the sun's disc, though the difference of light-intensity is enormous (Sully). Between these two is the *range of sensibility* (Wundt). There is always a constant ratio between the strength of the stimulus and the intensity of the sensation. The stronger the stimulus already applied, the stronger must be the increase of the stimulus in order to cause a perceptible increase of the sensation (*Weber's Law*). The necessary increment is proportional to the intensity of the stimulus, and it varies for each sense organ. If a weight of 10 grams be placed in the hand, it is found that 3.3 grams must be added or removed before a difference in the sensation is perceptible; if 100 grams are

held, 33·3 grams must be added or removed to obtain a perceptible difference in the sensation. The magnitude of the fraction indicating the increment of stimulus necessary to obtain a perceptible difference of the sensation is spoken of as the *constant proportion* or the *discriminative sensibility*. In the above case it is 1:3. The following table gives approximately the constant proportion for each sense:—

Tactile Sensation,	1 : 3. $\frac{1}{3}$
Thermal ,,	1 : 3. $\frac{1}{3}$
Auditory ,,	1 : 3. $\frac{1}{3}$
Muscular ,,	6 : 100. $\frac{6}{100}$
Visual ,,	1 : 100. $\frac{1}{100}$

The term, *after-sensation*, is applied to the following phenomenon, viz., that, as a rule, the sensation lasts longer than the stimulus producing it; thus there is an after-sensation after pressure is applied to the skin. *Subjective sensations* occur when stimuli, due to internal somatic causes, excite the nervous apparatus of the sense organ. The highest degrees of these, depending mostly upon pathological stimulation of the psycho-sensorial cortical centres, are characterised as *hallucinations*, e.g., when a delirious person imagines he sees figures or hears sounds which have no objective reality. In opposition to this condition the term, *illusion*, is applied to modifications by the sensorium of sensations actually caused by external objects, e.g., when the rolling of a waggon is mistaken for thunder.

In a **new-born child** the sense of touch is strongly developed, pain slightly, muscular sensations are undoubtedly present, while smell and taste are frequently confounded. Auditory stimuli are heard from the second day onwards, the stimulus of light immediately after birth, but a peripheral field of vision does not yet exist (Cuignet). Towards the 4th-5th week the movements of convergence and accommodation are noticeable, while, after four months, colours are distinguished. The various stimuli are not perceived simultaneously—a reflex inhibitory centre is not yet developed (Genzmer).

The Visual Apparatus—The Eye.

384. Anatomico-Histological Observations.

In the following remarks it is assumed that the student is familiar with the anatomical structure of the eye:—

The cornea, for the sake of simplicity, is regarded as uniformly spherical, although, properly speaking, it differs slightly from this form. It is more like a *vertical* section of a somewhat oblique ellipsoid, which we must suppose to be formed by rotating an ellipse around its long axis (Brücke). It is nearly of uniform thickness throughout, only in the infant it is slightly thicker in the centre, and in the adult slightly thinner. The cornea consists of the following layers:—

- [1. Anterior stratified epithelium.
2. Anterior elastic lamina.
3. Substantia propria.
4. Posterior elastic lamina.
5. Single layer of epithelium.]

1. The **anterior epithelium**, stratified and nucleated (Fig. 373, *a*), consists of many layers of cells. The deepest cells are more or less columnar, are arranged side by side, and are called supporting cells. The cells of the middle layers are more arched, and dip with finger-shaped processes into corresponding spaces between their neighbours. The most superficial cells are flat, perfectly smooth, hard, keratin-containing, squamous epithelium. 2. The epithelial layer rests upon the **anterior elastic membrane** (Bowman's elastic lamina), a structureless clear basement-like membrane (*b*), whose existence is denied by Brücke. 3. The **substantia propria** of the cornea consists of (chondrin-yielding) fibres (Johannes Müller, Rollett) composed of delicate fibrils of connective-tissue. The fibres are arranged in mat-like thin lamellæ (*l*), more or less united together, and are placed in layers over each other. Towards the anterior elastic lamina, the fibres bend round and perforate the superficial lamellæ, thus serving as supporting fibres. [These perforating fibres are comparable to Sharpey's fibres in bone.] Between the lamellæ are a series of intercommunicating spaces lined by endothelium. These spaces are really lymph-spaces, and they communicate with the lymphatics of the conjunctiva. The fixed **corneal corpuscles** (*c*) lie in these spaces, and are provided with numerous processes which anastomose with the processes of corpuscles lying between the lamellæ above and below them, and on either side of them. Kühne observed that stimulation of the corneal nerves was followed by contraction of these cells (p. 418, 7); while Kühne and Waldeyer maintain that they are connected with the corneal nerve-fibrils.

[The **corneal corpuscles** are looked upon as branched connective-tissue corpuscles lying in and not quite filling the branched spaces between the lamellæ. The processes anastomose freely with similar cells in the same plane, and to a less extent with the processes of cells in planes immediately above and below them. In a section stained with gold chloride, they present the appearance seen

in Fig. 371. In a vertical section of the cornea they appear fusiform (Fig. 373), and parallel to the free surface of the cornea. If the cornea of a frog be pencilled with silver nitrate, the cement substance between the lamellæ is blackened, and the branched cell-spaces remain clear, as in Fig. 372. The one figure represents, as it were, the positive, and the other the negative image.]

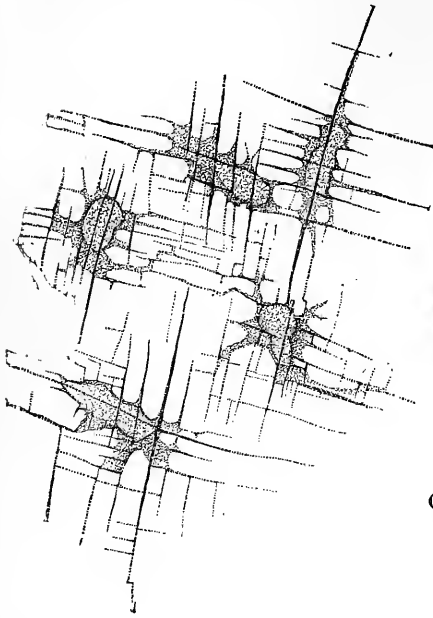

Fig. 371.

Cornea of the frog treated with chloride of gold, showing the corneal corpuscles stained, and a few nerve-fibrils.

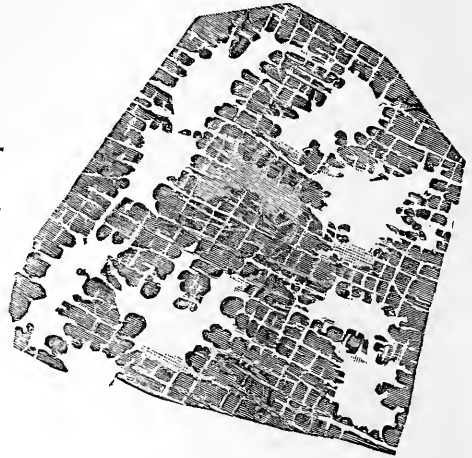

Fig. 372.

Cornea of the frog treated with silver nitrate—
The ground substance is stained, while the spaces for the corneal corpuscles are left unstained.

[Bowman's tubes are artificial productions, formed by forcing air or a coloured fluid between the lamellæ, when it passes between the bundles of fibrils forming a series of tubes with dilatations on them, and running at right angles to one another between the lamellæ.]

According to v. Recklinghausen, leucocytes also pass into these lymph-spaces or juice-canals. The importance of these leucocytes in inflammation is referred to at p. 414. 4. The transparent, structureless **posterior elastic membrane** (*d*), the membrane of Descemet or Demours, is in many animals fibrillated, and shows evidence of stratification; while, towards the margin of the cornea, there are occasionally slight conical elevations. This membrane is very tough, and very resistant (of great importance in inflammation). If it be removed, it rolls up towards the convex side. At its periphery, it becomes continuous with the fibro-elastic, reticulated ligamentum pectinatum iridis, whose trabeculæ are covered by epithelium. 5. The posterior **single layer of epithelium** consists of flat, delicate nucleated cells (*e*), which are continued from the margin of the cornea on to the anterior surface of the iris (*v*). Fine juice-canals exist in the spaces between the individual cells (v. Recklinghausen). These spaces communicate with a system of fine tubes under the epithelium, perforate Descemet's membrane, and thus communicate with the corneal spaces (Preiss).

The **nerves** of the cornea, which are derived from the long and short ciliary nerves (§ 347), are partly *sensory* in function. They enter the cornea at its margin as medullated fibres, but the myelin soon disappears, while the axial cylinders split up into fibrils. [The axial cylinders branch and form a plexus between the lamellæ, especially near the anterior surface, the *fundamental* or *ground plexus*. There are triangular nuclei at the nodal points, but they probably belong to the sheath of flattened cells which cover the larger branches. There is a finer and denser plexus of fibrils immediately under the anterior epithelium, sub-

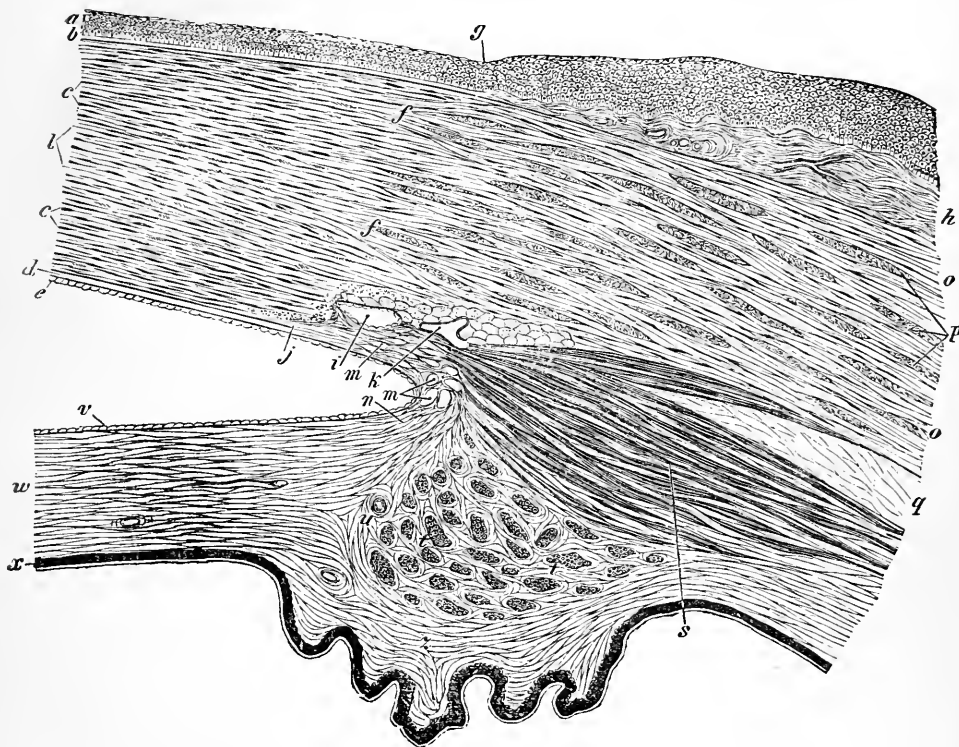

Fig. 373.

Antero-posterior section at the junction of the cornea with the sclerotic.

a, anterior corneal, or conjunctival epithelium; *b*, Bowman's lamina; *c*, corneal corpuscles lying in the juice canals; *l*, corneal lamellæ (the whole thickness lying between *b* and *d* is the substantia propria corneæ); *d*, Descemet's membrane; *e*, epithelium covering it; *f*, junction of cornea with the sclerotic; *g*, limbus conjunctivæ; *h*, conjunctiva; *i*, canal of Schlemm; *k*, Leber's venous plexus (is regarded by Leber as belonging to *i*); *m*, *m*, meshes in the tissue of the lig. iridis pectinatum; *n*, attachment of the iris; *o*, longitudinal, *p*, circular (divided transversely) bundles of fibres of the sclerotic; *q*, perichoroidal space; *s*, meridional [radiating]; *t*, equatorial (circular) bundles of the ciliary muscle; *u*, transverse section of a ciliary artery; *v*, epithelium of the iris (a continuation of that on the posterior surface of the cornea); *w*, substance of the iris; *x*, pigment of the iris; *z*, a ciliary process.

epithelial plexus, which is derived from the former, the fibrils arising in pencils or groups. Some fibrils perforate the anterior elastic lamina, *rami perforantes*, and pass between the anterior epithelial cells to form the *intra-epithelial net-work*. Some observers suppose that they terminate in free, pointed, or bulbous ends. There is also a fine plexus of fibrils in the posterior layers of the cornea, near Descemet's membrane. It gives off numerous fine fibrils, which come into intimate, if not direct, anatomical relation with the corneal corpuscles.]

[**Method.**—These fibrils are best revealed by staining a cornea with chloride of gold, which stains them of a purplish tinge after exposure to light (Cohnheim)].

The *trophic* fibres of the cornea (§ 347) are, perhaps, those deeper branches which are connected with the corneal corpuscles.

Blood-vessels occur only in the outer margin of the cornea (Fig. 374, *v*), and extend 2 mm. over the cornea above, 1.5 mm. below, and 1 mm. laterally—the most external capillaries form arched loops, and thus turn on themselves. The cornea is nourished from the blood-vessels in its margin. Opacities of the cornea give rise to many forms of visual defects.

The **sclerotic** is a thick, fibrous membrane, composed of, *p*, circular (equatorial) and, *o*, longitudinal (meridional) bundles of connective-tissue, woven together. The spaces between the bundles contain colourless and pigmented connective-tissue corpuscles (Waldeyer) and also leucocytes. It is thickest posteriorly, thinner at the equator, while in front of this it again becomes thicker, owing to the insertion of the tendons of the straight muscles of the eyeball. It contains few blood-vessels, which form a wide-meshed capillary plexus, immediately under its deep surface. Other vessels form an arterial ring around the entrance of the optic nerve. It rarely is quite spherical; it rather resembles an ellipsoid, which we might imagine to be formed by the rotation of an ellipse around its short axis (short eyes) or around its long axis (long eyes). Above and below, the sclerotic overlaps like a fold the clear margin of the cornea; hence, when the cornea is viewed from before, it appears transversely elliptical, when seen from behind, it appears circular. Following the margin of the cornea, but lying still within the substance of the sclerotic, is the circular *canal of Schlemm*, *i*, which communicates with other anastomosing veins, the venous plexus of Leber, *k*. Schwalbe and Waldeyer regard Schlemm's canal as a lymphatic. Posteriorly, the sclerotic becomes continuous with the fibrous covering of the optic nerve derived from the *dura mater*. The sclerotic is provided with nerves, which are said to terminate in the cells of the scleral substance (Helfreich, Königstein).

The **tunica uvea**, or the uveal tract, is composed of the choroid, the ciliary part of the choroid, and the iris.

The **choroid** is composed of the following layers:—1. Most internally is the transparent *limiting membrane*, 0.7 μ in thickness, but it is slightly thicker anteriorly. 2. The very vascular capillary net-work of the *chorio-capillaris*, or membrane of Ruysch, embedded in a homogeneous layer. Then follows—3. A layer of a thick *elastic net-work*, covered on both surfaces by endothelium (Sattler). 4. The *choroid proper* consists of a layer with pigmented connective-tissue corpuscles, together with a thick, elastic net-work, containing the numerous venous vessels, as well as the arteries. The pigmented layers, called the *supra-choroidea*, or *lamina fusca*, which surrounds the large lymphatic space lined with endothelium, and called the *perichoroidal space*, *q*. In new-born infants, which, according to Aristotle, have the iris dark blue, the uveal tissue is devoid of pigment; in brunettes it is developed later, and in blondes not at all.

In the **ciliary part** of the choroid, the pigmented connective-tissue corpuscles are not so numerous. The **ciliary muscle** (tensor choroideæ, or muscle of accommodation) is placed in this region. It arises, *s*, by means of a branched, reticulated, connective-tissue origin, from the inner side of the junction of the cornea and sclerotic, near the canal of Schlemm, and passes backwards to be inserted into

the choroid. This constitutes the *radiating fibres*. Other fibres lying internal to these are arranged *circularly*, *t*, in bundles in the ciliary margin. These circular fibres are sometimes called Heinrich Müller's muscle. The muscle consists of smooth muscular fibres, and is supplied by the oculomotorius (§ 345, 3).

The **iris** consists of the following parts from before backwards—a layer of epithelial cells (*v*) continuous with those covering the posterior surface of the cornea, a layer of reticulated connective-tissue, the layer of blood-vessels, and, lastly, a posterior limiting membrane, which contains the pigmentary epithelium (*x*), (Michel). In brunettes, the texture of the iris contains pigmented connective-tissue corpuscles. The iris contains two muscles composed of smooth muscular fibres—one set constituting the *sphincter pupillæ* (circular—Fig. 387), which surrounds the pupil, and lies nearer the posterior than the anterior surface of the iris. Its nerve of supply is derived from the oculomotorius (§ 345, 2). The other fibres constitute the *dilator pupillæ* (radiating), which consists of a thinner layer of fibres arranged in a radiate manner. Some of the fibres reach to the margin of the pupil, while others bend into the sphincter. At the outer margin of the iris, the radial bundles are arranged in anastomosing arches, and form a circular muscular layer (Merkel). The chief nerve of supply for the dilator fibres is the sympathetic (§ 347, 3). Ganglia occur in the ciliary nerves in the choroid [and they are found also in the iris]. Gerlach has recently applied the term *ligamentum annulare bulbi*

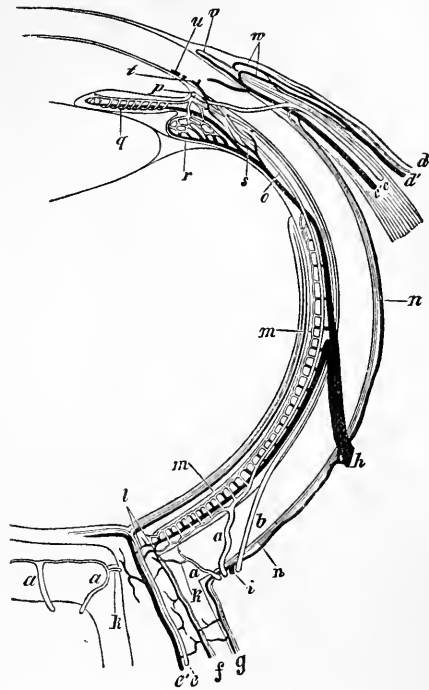

Fig. 374.

Diagrammatic representation of the blood-vessels of the eye, according to Leber.

Horizontal view, veins black, arteries light, and with a double contour—*a, a*, short posterior ciliary; *b*, long posterior ciliary; *c, c'*, anterior ciliary, artery, and vein; *d, d'*, artery and vein of the conjunctiva; *e, e'*, central artery and vein of retina; *f*, blood-vessels of the inner, and *g*, of the outer optic sheath; *h*, vorticosae vein; *i*, posterior short ciliary vein confined to the sclerotic; *k*, branch of the posterior short ciliary artery to the optic nerve; *l*, anastomosis of the choroidal vessels with those of the optic; *m*, choriocapillaris; *n*, episcleral branches; *o*, recurrent choroidal artery; *p*, great circular artery of iris (transverse section); *q*, blood-vessels of the iris; *r*, ciliary process; *s*, branch of a vorticosae vein from the ciliary muscle; *t*, branch of the anterior ciliary vein to the ciliary muscle; *u*, circular vein; *v*, marginal loops of vessels on the cornea; *w*, anterior artery and vein of the conjunctiva.

to that complex fibrous arrangement which surrounds the iris, and at the same time forms the point of union of the ciliary body, iris, ciliary muscle, sinus venosus iridis, and the line of junction of the cornea and sclerotic.

The **choroidal vessels** are of great importance in connection with the nutrition of the eye. According to Leber, they are arranged as follows:—The **arteries** are 1. The short posterior ciliary (Fig. 374, *a, a*), which are about 20 in number, and perforate the sclerotic near the optic nerve. They terminate in the vascular network of the choriocapillaris (*m*), which reaches as far as the ora serrata. 2. The long posterior ciliary, one lies on the nasal, and the other on the temporal side, and they run (*b*) to the ciliary part of the choroid, where they divide dichotomously, and penetrate into the iris, where they help to form the circulus arteriosus iridis major (*p*). 3. The anterior ciliary (*c*), which arise from the muscular branches, perforate the sclerotic anteriorly, and give branches to the ciliary part of the choroid, and to the iris. About 12 branches run backwards (*o*) from them to the choriocapillaris.

The **Veins**.—1. The anterior ciliary veins (*c*) receive the blood from the anterior part of the uvea, and carry it outwards. These branches are connected with Schlemm's canal and Leber's venous plexus. They do not receive any blood from the iris. 2. The venous plexus of the ciliary processes (*r*) receives the blood from the iris (*q*), and passes backwards to the choroidal veins. 3. The large vasa vorticosa Stenonis (*h*) perforate the sclerotic behind the equator of the bulb.

The inner margin of the iris rests upon the anterior surface of the lens; the posterior chamber is small in adults, and in the new-born child it may be said scarcely to exist, it is so small. When Berlin blue is injected into the anterior chamber of the eye, it generally passes into the anterior ciliary veins (Schwalbe). Even in living animals carmin also behaves in a similar manner (Heisrath), so that these observers conclude that there is a *direct* communication between the veins and the aqueous chamber, as these substances do not diffuse through membranes.

Internal to the choroid lies the single layer of hexagonal cells (0·0135–0·02 mm. in breadth) filled with crystalline pigment. This layer really belongs to the retina. It consists of a single layer of cells as far as the ora serrata—it is continued on to the ciliary processes and the posterior surface of the iris (Fig. 373, *x*), where it forms several layers. In albinos it is devoid of pigment; on the other hand, the uppermost cells, which lie on the ridges of the ciliary processes, are always devoid of pigment.

The **retina** externally is in contact with the layer of hexagonal pigment cells (*Pi*), which, in its development and functions, really belongs to the retina. The cells are not flat, but they send pigmented processes into the spaces between the ends of the rods. In some animals (rabbit) the cells contain fatty granules and other substances. The cells are larger and darker at the ora serrata (Kühne). The retina is composed of the following layers, proceeding from without inwards:—

1. Layer of pigment cells.
2. Rods and cones.
(*External limiting membrane.*)
3. Outer nuclear layer.
4. Outer molecular, granular (internuclear) layer.
5. Inner nuclear layer.
6. Inner molecular (granular) layer.
7. Layer of nerve-cells (ganglionic) layer.
8. Layer of nerve-fibres.]
(*Internal limiting membrane.*)

1. The *hexagonal pigment cells* already described. 2. The layer of *rods and cones* (*St*) or *neuro-epithelium* of Schwalbe [*bacillary layer*, or the *visual cells*, or *visual epithelium* of Kühne] (Fig. 375). These lie externally next the choroid, but they are

absent at the entrance of the optic nerve. Then follows the *external limiting membrane* (*Le*), which is perforated by the bases of the rods and cones. 3. The *external nuclear layer* (*äu.K*), which, with all the succeeding layers, are called "brain layers" by Schwalbe. 4. The *external granular* (*äu.gr*), or internuclear layer, which is perforated by the fibres which proceed inwards from the nuclei of 3 (Merkel) to reach 5, the nuclei of the *internal nuclear layer* (*in.K*). The nuclei of this layer, which are connected by fibres with the rods and cones, are marked by transverse lines in the macula lutea (Krause, Denissenko). 6. The finely granular *internal granular layer* (*in.gr*), through which the fibres proceeding from the inner nuclear layer cannot be traced. It would seem as if these fibres break up into the finest fibrils, into which also the branched processes of the ganglionic cells of 7, the *ganglionic layer*, extend. According to v. Vintschgau, the processes of the ganglionic cells are connected with the fibres. 8. The next, or fibrous layer, consists of the *fibres of the optic nerve* (*o*), and, most internally, is the *internal limiting membrane* (*Li*). According to W. Krause, there are 400,000 broad, and as many narrow, optic fibres, so that, for every fibre, there are 7 cones, about 100 rods, and 7 pigment cells. The optic fibres are absent from the macula lutea, where, however, there are numerous ganglionic cells. Between the two homogeneous limiting membranes (*Le* and *Li*) lies the *connective-tissue substance* of the retina. It contains the perforating fibres, or **Müller's fibres**, which run in a radiate manner between the two membranes and hold the various layers of the retina together. They begin by a wing-shaped expansion at the internal limiting membrane (*Rk*), and in their course outwards contain nuclei (*k*). They are absent at the yellow spot. The supporting tissue forms a net-work in all the layers, holes being left for the nervous portions (*Sg*). The inner segments of the rods and cones are also surrounded by a sustentacular substance. As the retina passes forward to the ora serrata it becomes thinner and thinner, gradually becoming richer in connective-tissue elements and poorer in nerve elements, until, in the ciliary part, only the cylindrical cells remain.

[Macula Lutea and Fovea Centralis.—There are no rods in the fovea, while the cones are longer and narrower than in the other parts of the retina. The other layers also are thinner, especially at the macula lutea, but they become thicker towards the margins of the fovea, where the ganglionic layer consists of several rows of bipolar cells. The yellow tint is due to pigment lying between the layers composing the yellow spot.]

The **blood-vessels** of the retina lie in the *inner* layers near the inner granular layer. Only near the entrance of the optic nerve are they connected by fine branches with the choroidal vessels; they are surrounded by perivascular lymph spaces. The greatest number of capillaries runs in the layers external to the inner granular layer (Hesse, His). The fovea centralis is devoid of blood-vessels (Nettleship, Becker). Except in mammals, the eel (Denissenko), and some tortoises (H. Müller), the retina receives no blood-vessels. Destruction of the retina is followed by blindness.

[Retinal Epithelium.—The single layer of pigmentary cells containing granules of melanin sends processes downwards, like the hairs of a brush, between the rods and cones. Kühne has shown that the nature and amount of light influences the condition of these processes. The protoplasm of these cells in a frog, kept for several hours in the dark, is retracted, and the pigment granules lie chiefly in the body of the cell and in the processes near the cell. In a frog kept in bright daylight, the processes loaded with pigment penetrate downwards between the rods and cones as far as the external limiting membrane.]

Each rod and cone consists of an outer and an inner segment. During life, the outer segment contains a reddish pigment (Boll).

Visual purple [or **rhodopsin**] may be preserved by keeping the eye in

darkness, but it is soon bleached by daylight; while it is again restored when the eye is placed in darkness. It can be extracted from the retina by means of a

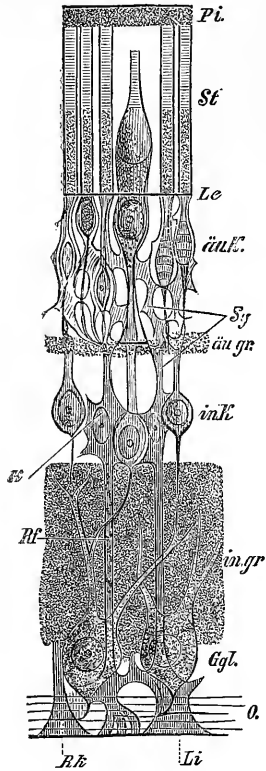

Fig. 375.

Layers of the retina—*Pi*, hexagonal pigment cells; *St*, rods and cones; *Le*, ext. limiting membrane; *äü.K.*, external nuclear layer; *äü.gr.*, ext. granular layer; *in.K.*, internal nuclear; *in.gr.*, int. granular; *Ggl.*, ganglionic nerve-cells; *a.*, fibres of optic nerve, with their processes, *Rf.*; *Li*, int. limit. membrane; *Rk.*, fibres of Müller; *K.*, nuclei; *Sy.*, spaces for the nervous elements.

fades rapidly at a temperature of 50–76°C., while trypsin, alum, and ammonia do not affect it. It is restored in the retina by the action of the retinal epithelium. If the retinal epithelium or choroid be lifted off from an excised eye exposed to light, the purple is destroyed, but if the eye be placed in darkness and the retinal epithelium replaced, the colour is restored.]

Chemistry of the Retina.—The reaction of the retina, when quite fresh, is

2.5 per cent. solution of the bile acids, especially from eyes that have been kept in 10 per cent. solution of common salt (Ayres). The rods are 0.04–0.06 mm. high and 0.0016–0.0018 mm. broad, and exhibit longitudinal striation, produced by the presence of fine grooves; a fine fibril runs in their interior (Ritter). The external segment occasionally cleaves transversely into a number of fine transparent discs. [It is a very resistant structure, and in this respect resembles neuro-keratin.] Krause found an ellipsoidal body, the “rod ellipsoid,” at the junction of the inner and outer segments of the rods. The cones are devoid of visual purple, but their outer segment is striated longitudinally, and it also readily breaks across into thin discs. Only cones are present in the macula lutea. In the neighbourhood of the yellow spot, each cone is surrounded by a ring of rods. The cones become less numerous towards the periphery of the retina. In nocturnal animals, such as the owl and bat, there are either no cones or imperfect ones. The retinae of birds contain many cones; that of the tortoise only cones. The rods and cones rest on the sieve-like perforated external limiting membrane (*Le*). Both send processes through the membrane, the cones to the larger and higher-placed nuclei, the rods to the nuclei with transverse markings, in the external nuclear layer. [The cones are particularly large in some fishes, e.g., the cod, while the skate has no cones, but only rods. The same is the case in the shark and sturgeon, hedgehog, bat, and the mole.]

[Distribution and Regeneration of Rhodopsin.—Keep a rabbit in the dark for some time, kill it, remove its eyeball, and examine its retina by the aid of monochromatic (sodium) light. The retina will be purple-red in colour, all except the macula lutea and a small part at the ora serrata. The pigment is confined to the *outer segments of the rods*. It is absent in pigeons, hens, and one bat, although the last has only rods. It is found both in nocturnal and diurnal animals.

Its colour is quickly bleached by light, and it

acid, and becomes alkaline in darkness. The rods and cones contain albumin, neuro-keratin, nuclein, and in the cones are the pigmented oil globules, the so-called "*chromophanes*." The other layers contain the constituents of the grey matter of the brain.

[**Cones.**—There is no colouring matter in the outer segment of the cones, but in fishes, reptiles, and birds the inner segment contains a globular coloured body often red and yellow, the pigment being held in solution by a fatty body. Kühne has separated a green (*chlorophane*), a yellow (*xanthophane*), and a red (*rhodophane*) pigment. They all give a blue with iodine (Schwalbe), and are bleached by light.]

The **crystalline lens** is enclosed in a transparent capsule, thicker anteriorly than posteriorly, and it is covered on the inner surface of the anterior wall by a layer of low epithelium. Towards the margin of the lens, these cells elongate into nucleated fibres (Robinski), which all bend round the margin of the lens, and on both sides of the lens abut with their ends against each of the triradiate figures.

The lens fibres contain globulin enclosed in a kind of membrane. Owing to mutual pressure, they are hexagonal when seen in transverse section (Fig. 376, 2), while in many animals, especially fishes, their margins are serrated, [the teeth dovetail into each other].

For the sake of simplicity, we may regard the lens as a biconvex body with spherical surfaces, the posterior surface being more curved. As a matter of fact, the anterior part is part of an ellipsoid, formed by rotation on its short axis. The posterior surface resembles the section of a paraboloid, *i.e.*, we might regard it as formed by the rotation of a parabola on its axis (Brücke). The outer layers of the lens have less refractive power than the more internal layers. The central part of the lens [or nucleus] is, at the same time, firmer, and more convex than the entire lens. The margin of the lens is always separated from the ciliary processes by an intermediate space.

[**Chemistry.**—The lens contains about two-thirds of its weight of water, while its chief solid is a globulin, called by Berzelius *crystallin* (24.6 per cent.), with a little serum-albumin, salts, cholesterin, and fats.]

[**Cataract.**—Sometimes the lens becomes more or less opaque, the opacity beginning either in the middle or outer parts of the lens. This is generally due to fatty degeneration of the fibres, cholesterin being deposited. An opaque cataractous condition of the lens may be produced in frogs by injecting a solution of some salts or sugar into the lymph sacs; the result is that these salts absorb the water from the lens, and thus make it opaque. The cataract of diabetes is probably produced from the presence of grape-sugar in the blood.]

The **zonule of Zinn**, at the ora serrata, is applied as a folded membrane to the ciliary part of the uvea, so that the ciliary processes are pressed into its folds, and are united to it. It passes to the margins of the lens, where it is inserted by a series of folds into the anterior part of the capsule of the lens. Behind the zonule of Zinn, and reaching as far as the vitreous humour, is the *canal of Petit*. The zonule is a fibrous perforated membrane (Schwalbe, Vlacowitsch). According to

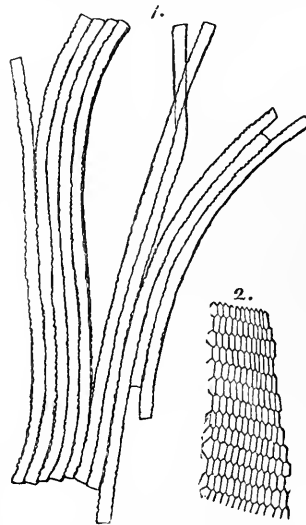

Fig. 376.

1, Fibres of the lens; 2, transverse sections of the lens fibres.

Merkel, the canal of Petit is enclosed by very fine fibres, so that it is really not a canal, but a complex communicating system of spaces (Gerlach). Nevertheless, the zonule represents a stretched membrane, holding the lens in position, and may, therefore, be regarded as the *suspensory ligament* of the lens.

Opacity or cloudiness of the lens (grey cataract) hinders the passage of light into the eye. The absence of the lens (*Aphakia*), as after operations for cataract, may be remedied by a pair of strong convex spectacles. Of course, such an eye does not possess the power of accommodation.

The **vitreous humour**, as far as the ora serrata, is bounded by the internal limiting membrane of the retina (Henle, Iwanoff). From here forwards, lying between both, are the meridional fibres of the zonule, which are united with the surface of the vitreous and the ciliary processes. A part of the fibrous layer bends into the saucer-shaped depression, and bounds it. A canal, 2 mm. in diameter, runs from the optic papilla to the posterior surface of the capsule of the lens, it is called the *hyaloid canal*, and was formerly traversed by blood-vessels. The peripheral part of the vitreous humour is laminated like an onion, the middle is

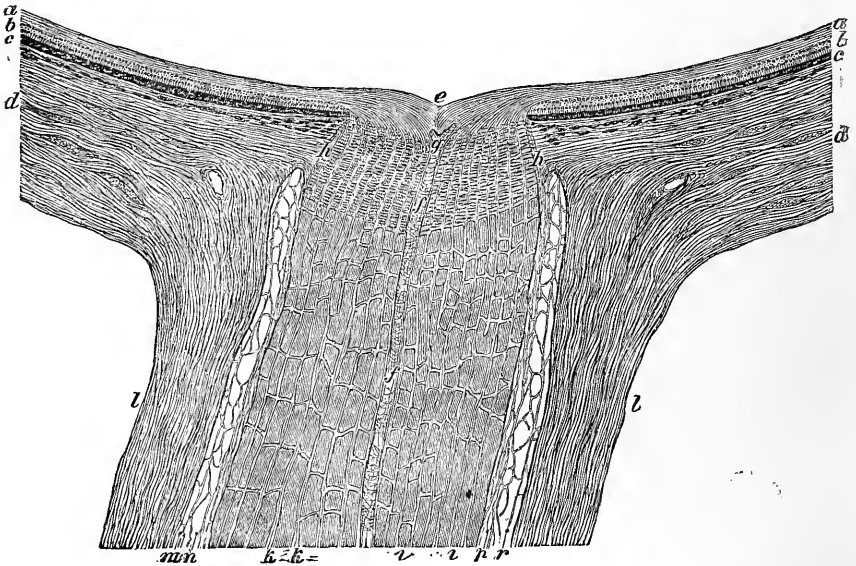

Fig. 377.

Horizontal section through the optic nerve at its entrance into the eye, and through the coats of the eye.

a, Inner, *b*, outer layers of the retina; *c*, choroid; *d*, sclerotic; *e*, physiological cup; *f*, central artery of retina in axial canal; *g*, its point of bifurcation; *h*, lamina cribrosa; *l*, outer (dural) sheath; *m*, outer (subdural) space; *n*, inner (subarachnoid) space; *r*, middle (arachnoid) sheath; *p*, inner (pial) sheath; *i*, bundles of nerve-fibres; *k*, longitudinal septa of connective-tissue.

homogeneous; in the former, especially in the foetus, are round fusiform or branched cells of the mucous tissue of the vitreous, while in the centre there are disintegrated remains of these cells (Iwanoff). The vitreous contains a very small percentage of solids, and 1.5 per cent. of *mucin*, [and, according to Picard, there is 0.5 per cent. of urea, and about .75 of sodic chloride].

[**Structure.**—The vitreous consists essentially of *mucous tissue*, in whose meshes lies a very watery fluid containing the organic and inorganic bodies in solution. According to Younan, the vitreous contains two types of cells—(1) *amaboid* cells of various shapes and sizes. They lie on the inner surface of the lining hyaloid membrane, and the other membranes in the cortex of the vitreous; (2) large *branching* multipolar cells. The vitreous is permeated by a large number of transparent, clear, homogeneous *hyaloid membranes*, which are so disposed as to give rise to a concentric lamination. The *canal of Stilling* represents in the adult the situation of the hyaloid artery of the foetus. It can readily be injected by a coloured fluid. In preparations of the vitreous, Younan finds fibres not unlike elastic fibres, and other fibres more especially after staining with chloride of gold, but as yet he cannot say that the latter fibres are nervous in their characters.]

The **lymphatics** of the eye consist of an anterior and a posterior set (Schwalbe). The *anterior* consist of the anterior and posterior chambers of the eye (aqueous), which communicate with the lymphatics of the iris, ciliary processes, cornea, and conjunctiva.

The *posterior* consist of the perichoroideal space between the sclerotic and the choroid (Schwalbe). This space is connected by means of the perivascular lymphatics around the trunks of the vasa vorticiosa, with the large lymph-space of Tenon, which lies between the sclerotic and Tenon's capsule (Schwalbe). Posteriorly this is continued into a lymph-channel, which invests the surface of the optic nerve; while anteriorly it communicates directly with the sub-conjunctival lymph-spaces of the eyeball (Gerlach). The optic nerve has *three* sheaths—1, the dural; 2, the arachnoid; and 3, the pial sheath, derived from the corresponding membranes of the brain. Two lymph-spaces lie between these three sheaths—the subdural space between 1 and 2, and the subarachnoid space between 2 and 3 (Fig. 377). Both spaces are lined by endothelium; and the fine trabeculae passing from one wall to the other are similarly covered. According to Axel Key and Retzius, these lymph-spaces communicate anteriorly with the perichoroideal space.

The **aqueous humour** closely resembles the cerebrospinal fluid, and contains albumin and sugar; the former is increased, and the latter disappears after death. The same occurs in the vitreous. The albumin increases when the difference between the blood-pressure and the intraocular pressure rises. Such variations of pressure, and also intense stimuli applied to the eye cause the production of fibrin in the anterior chamber (Jesner and Grünhagen).

Intraocular Pressure.—The cavity of the bulb is practically filled with watery fluids, which, during life, are constantly subjected to a certain pressure, the "intraocular pressure." Ultimately, this depends upon the blood-pressure within the arteries of the retina and uvea, and must rise and fall with it. The pressure is determined by pressing upon the eyeball, and ascertaining whether it is tense, or soft and compressible. Just as in the case of the arterial pressure, the intraocular pressure is influenced by many circumstances; it is increased at every pulse-beat and at every expiration, while it is decreased during inspiration. The elastic tension of the sclerotic and cornea regulates the increase of the arterial pressure, by acting like the air-chamber in a fire-engine; thus, when more arterial blood is pumped into the eyeball, more venous blood is also expelled. The constancy of the intraocular pressure is also influenced by the fact that, just as the aqueous humour is removed it is secreted, or rather formed, as rapidly as it is absorbed (§ 392).

The **secretion of the aqueous humour** occurs pretty rapidly, as may be surmised from the fact that hæmoglobin is found in the aqueous humour half an hour after dissolved blood (lamb's) is injected into the blood-vessels of a dog. It is rapidly reformed, after evacuation, through a wound in the cornea. According to Knies, the watery fluid within the eyeball is secreted, especially from the choriocapillaris, and reaches the suprachoroideal space, in the lymph-sheaths of

the optic nerve, and partly through the net-work of the sclerotic. It saturates the retina, vitreous, lens, and for the most part passes through the zonula ciliaris into the posterior chamber, and through the pupil into the anterior chamber. The movements of the fluid within the eyeball have been recently studied by Ehrlich, who used *fluorescin*, an indifferent substance, which, on being introduced into the body, passes into the fluids of the eyeball, and, in a very dilute solution, may be recognised by its green fluorescence in reflected light. From observations on the entrance of this substance into the eye, Schöler and Uthhoff regard the posterior surface of the iris, and the ciliary body as the secretory organs for the aqueous humour. It passes through the pupil into the anterior chamber, some passes into the lens, and along the canal of Petit into the vitreous humour (Pflüger). Section of the cervical sympathetic, and still more of the trigeminus, accelerates the secretion of the aqueous, but its amount is diminished. If the substance is dropped into the conjunctival sac it percolates towards the centre of the cornea, and through the latter into the anterior chamber (Pflüger).

The **outflow** of the aqueous humour, according to Leber and Heisrath, takes place chiefly between the meshes of the ligamentum pectinatum iridis (Fig. 373, *m*, *m*), through which it passes into the channels of the circulus venosus, and the canal of Schlemm (*i*, *k*). A very small part of the aqueous passes through the cornea into the sub-conjunctival connective-tissue, and even into the conjunctival sac. After burning the limbus corneæ with a hot needle, this outflow is arrested, the eyeball becomes very hard, so that the intrabulbar vessels are subjected to high pressure (Schöler). Perhaps there is a direct communication between the anterior ciliary veins and the anterior chamber (p. 960). None of the water is conducted from the eyeball by any special efferent lymphatics (Leber). Under normal circumstances, the pressure is nearly the same in the vitreous and aqueous chambers, but atropin seems to diminish the pressure in the former, and to increase it in the latter, whilst Calabar bean has an opposite action (Ad. Weber). Arrest of the outflow of the venous blood often increases the pressure in the vitreous, and diminishes that in the aqueous chamber. Compression of the bulb from without causes more fluid to pass out of the eye, temporarily, than enters it. The diminution of the intraocular pressure is well-marked after section of the trigeminus, while it rises when this nerve is stimulated. The statements vary regarding the effect of the sympathetic nerve upon the pressure. Interruption to the venous outflow increases the pressure, while an imperfect supply of blood, the outflow being normal, diminishes the pressure. The innervation of the blood-vessels of the eye is referred to at § 347.

385. Dioptric Observations.

The eye as an optical instrument is comparable to a *camera obscura*; in both an *inverted diminished* image of the objects of the external world is formed upon a back-ground, the field of projection. [In the case of the eye this is represented by the retina.] Instead of the single lens of the camera, the eye has *several refractive media* placed behind each other—cornea, aqueous humour, lens (whose individual parts—capsule, cortical layers, and nucleus, all possess different refractive indices), and vitreous humour. Every two of these adjacent media are bounded by a “*refractive surface*,” which may be regarded as spherical. The field of projection of the eye is the retina, which is coloured with the visual purple (Boll, Kühne). As this substance is bleached chemically by the direct action of light, so that the pictures may be temporarily fixed upon the retina, the comparison of the eye with the camera of the photographer becomes more striking. In order that the passage of the rays of light through the media of the eye may be rightly understood, we must know the following factors:—1. The refractive indices of all the media. 2.

The form of the refractive surfaces. 3. The distance of the various media from each other and from the field of projection [retina].

Action of a Converging Lens.—We must know how a convex lens acts upon light. In a convex lens we distinguish the centre of curvature (Fig. 378, I, m, m_1), *i.e.*, the centre of both spherical surfaces. The line connecting both is called the *chief axis*; the centre of this line is the *optical centre* of the lens (o). All rays which pass through the optical centre of the lens pass through unbenet or without being refracted; they are called the chief or principal rays (n, n_1). The following are the laws regulating the action of a convex lens upon rays of light :—

1. Rays which fall upon the lens, parallel with the principal axis (II, f, a), are so refracted that they are collected on the other side of the lens, at a point called the focus or principal focus (f). The distance of this point from the central point (o) of the lens, is called the focal distance (f, o) of the lens. The converse of this condition is evident, *viz.*, rays which diverge from a focus and reach the lens pass through it to the other side, parallel with the principal axis, without again coming together.

2. Rays of light proceeding from a source of light (IV, l) in the prolonged principal axis, but *beyond* the focal point (f), again converge to a point on the other side of the lens. The following cases may occur :—(a) When the distance of the light from the lens is equal to twice the focal distance, the focus or point of convergence lies at the same distance on the other side of the lens, *i.e.*, twice the focal distance. (b) If the luminous point be moved nearer to the focus, then the focal point is moved further away. (c) If the light is still further from the lens than twice the focal distance, then the focal point comes correspondingly near to the lens.

3. Rays proceeding from a point of the chief axis (III, b) within the focal distance pass out at the other side, less divergent, but do not come to a focus again.

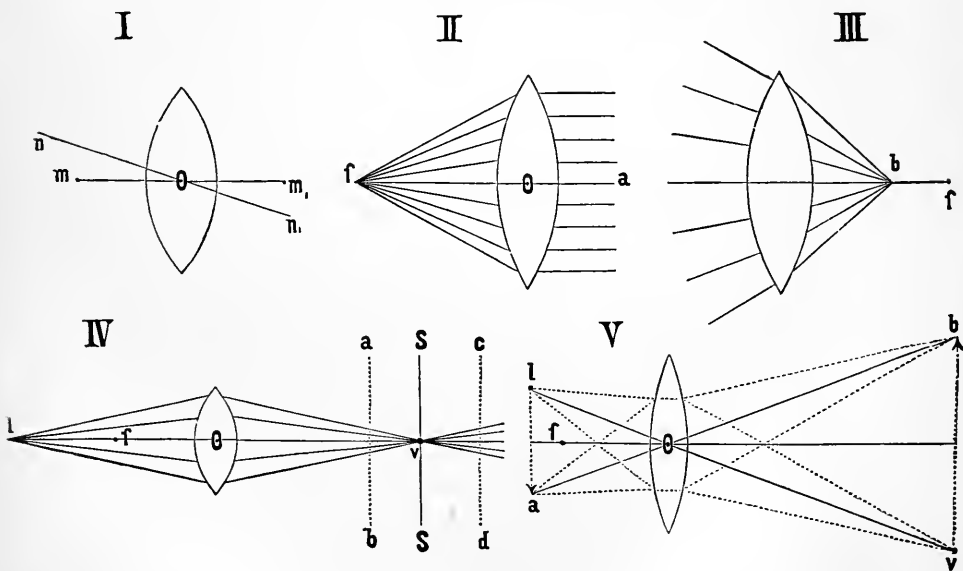

Fig. 378.

The above figures illustrate the action of lenses upon rays of light passing through them.

Conversely, rays which are convergent and pass through a collecting lens, have their focal point within the focal distance.

4. If the luminous point (V, a) is placed in the secondary ray (a, b), the same laws obtain, provided the angle formed by the secondary ray with the principal axis is small.

Formation of Images by Convex Lenses.—After what has been stated regarding the position of the point of convergence of rays proceeding from a luminous point, the construction of the image of any object by a convex lens is easily accomplished. This is done simply by projecting images of the various parts of the object. Thus, evidently in V, b is the focal point of the object, a , while v is the focal point of the object, l . The picture is *inverted*. *Collecting lenses form an inverted and real image (i.e., upon a screen) only of such objects as are placed beyond the focal point of the lens.*

With regard to the size and distance of the image from the lens, there are the following cases:—(a) If the object be placed at twice the focal distance from the lens, the image of the same is just the same size and at the same distance from the lens as the object is. (b) If the object be nearer than the focus, the image recedes and, at the same time, becomes larger. (c) If the object be further removed from the lens than twice the focal distance, then the image is nearer to the lens and, at the same time, becomes smaller.

Position of the Focal Point.—The distance of the focal point from the lens is readily calculated, according to the following formula:—Where l =the distance of the luminous point, b =the distance of the image, and f =the focal distance

of the lens: $\frac{1}{l} + \frac{1}{b} = \frac{1}{f}$, or $\frac{1}{b} = \frac{1}{f} - \frac{1}{l}$.

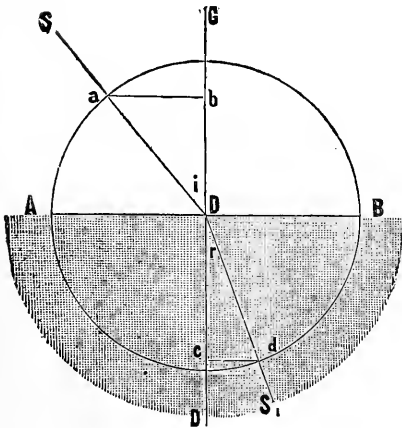

Fig. 379.

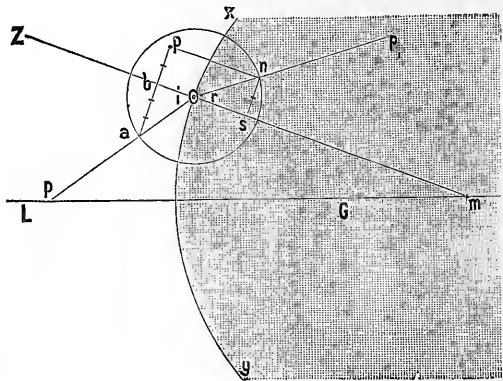

Fig. 380.

Example.—Let $l=24$ centimetres, $f=6$ cm. Then $\frac{1}{b} = \frac{1}{6} - \frac{1}{24} = \frac{1}{8}$; so that $b=8$ cm., i.e., the image is formed 8 cm. behind the lens. Further, let $l=10$ cm., $f=5$ cm. (i.e., $l=2f$). Then $\frac{1}{b} = \frac{1}{5} - \frac{1}{10} = \frac{1}{10}$; so that $b=10$, i.e., the image is placed at twice the focal distance of the lens. Lastly, let $l = \infty$. Then $\frac{1}{b} = \frac{1}{f} - \frac{1}{\infty}$; so that $b=f$, i.e., the image of parallel rays coming from infinity lies in the focal point of the lens.

Refractive Indices.—A ray of light, which passes in a perpendicular direction from one medium into another medium of *different* density, passes through the latter without changing its course or being refracted. In Fig. 379, if GD , is $\perp AB$, then so is DD , $\perp AB$; for a plane surface AB is the horizontal, and GD the vertical line. If the surface is spherical, then the vertical line is the prolonged radius of this sphere. If, however, the ray of light falls *obliquely* upon the surface, it is “refracted,” *i.e.*, it is bent out of its original course. The incident and the refracted ray nevertheless lie in *one plane*. When the oblique incident ray passes from a *less dense* medium (*e.g.*, air) into one *more dense* (*e.g.*, water), the refracted or excited ray is bent *towards* the perpendicular. If, conversely, it pass from a more dense to a less dense medium, it is bent away from the perpendicular. The angle (i , GD S) which the incident ray (SD) forms with the perpendicular (GD) is called the *angle of incidence*, the angle formed by the refracted ray (DS_1) with the prolonged perpendicular (DD) is called the *angle of refraction*, $DD S_1$ (r). The refractive power is expressed as the “*refractive index*.” The term refractive index (n) means that number which shows for a certain substance how many times the sine of the angle of incidence is greater than the sine of the angle of refraction, when a ray of light passes from the air into that substance. Thus, $n = \sin. i : \sin. r = ab : cd$. On comparing the refractive indices of two media, we always assume that the ray passes from *air* into the medium. On passing from the air into water, the ray of light is so refracted that the sine of the angle of incidence is to the sine of the angle of refraction, as 4:3; the refractive index is $\frac{4}{3}$ (or more exactly = 1.336). With glass the proportion is = 3:2 (= 1.535—(Snellius, 1620, Descartes).

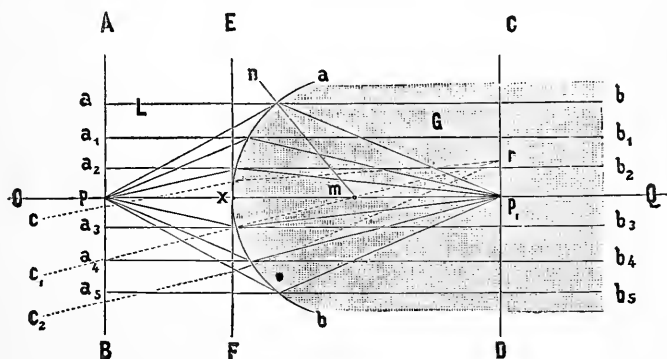

Fig. 381.

The construction of the refracted ray, the refractive index being given, is simple:—**Example**—Suppose in Fig. 380, L = the air, G = a dense medium (glass) with a spherical surface, xy , and with its centre at m ; po = the oblique incident ray, then mZ is the perpendicular, $\angle = i$ the angle of incidence. The refractive index given is $\frac{3}{2}$; the object is to find the direction of the refracted ray.

From o as centre, describe a circle with a radius of any length; from a draw a perpendicular, ab to mZ ; then ab is the sine of the angle of incidence, i . Divide the line ab into three equal parts, and prolong it, to the extent of two of these parts, *viz.*, to p . Draw the line p parallel to mZ . The line joining o to n is the direction of the refracted ray. On making a line, ns , perpendicular to mZ , $ns = bp$. Further, $ns = \text{sine } \angle = r$. So that $ab : sn$ (or $: bp$) = 3 : 2 or $\sin. i : \sin. r = \frac{3}{2}$.

Optical Cardinal Point of a Simple Collecting System.—Two refractive media (Fig. 381, L and G) which are separated from each other by a spherical surface (a, b) form a simple collecting system. It is easy to estimate the construction of an incident ray coming from the first medium (L) and falling obliquely upon the surface (a, b) separating the two media, as well as to ascertain its direction in the second medium, G, and also from the position of a luminous point in the first medium to estimate the position of the corresponding focal point in the second medium. The factors required to be known are the following:—L (Fig. 381) is the first, and G the second medium, a, b = the spherical surface whose centre is m . Of course, all the radii drawn from m to a, b ($m x, m n$) are perpendiculars, so that all rays falling in the direction of the radii must pass unrefracted through m . All rays of this sort are called rays or *lines of direction*; m , as the point of inter-

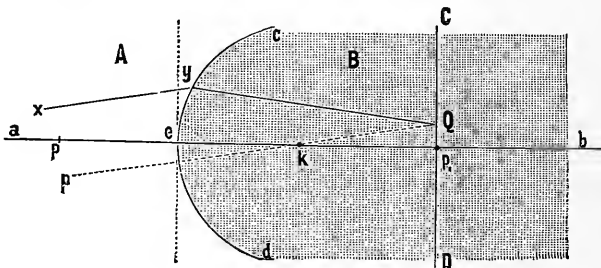

Fig. 382.

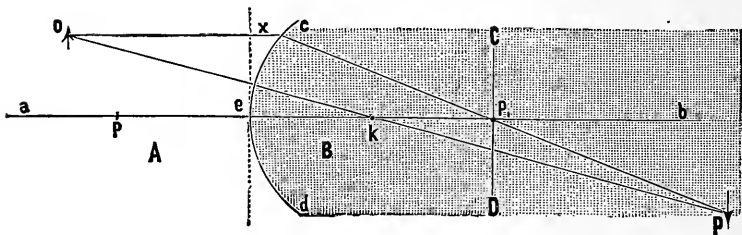

Fig. 383.

section of all these, is called the *nodal point*. The line which connects m with the vertex of the spherical surface, x , and which is prolonged in both directions, is called the *optic axis*, OQ . A plane (E, F) in x , perpendicular to OQ , is called the *principal plane*, and in it x is the *principal point*. The following facts have been ascertained:—1. All rays (a to a_5), which in the first medium, are parallel with each other and with the optic axis, and fall upon ab , are so refracted in the second medium, that they are all again united in one point (p_1) of the second medium. This is called the *second principal focus*. A plane in this point, perpendicular to OQ , is called the *second focal plane* (C, D). 2. All rays (c to c_2), which in the first medium are parallel to each other, but not parallel to OQ , reunite in a point of the second focal plane (r), where the non-refracted directive ray ($c_1, m r$) meets this. (In this case the angle formed by the rays c to c_2 with CQ must be very small.) The propositions 1 and 2, of course, may be reversed; the divergent rays proceeding from p towards ab pass into the first medium parallel to each other, and also with the axis C, Q (a to a_5); and the rays proceeding from r pass into the first medium parallel to each other, but not parallel to the axis OQ (as c to

c_2). 3. All rays, which in the second medium are parallel to each other (b to b_2) and with the axis OQ , reunite in a point in the first medium (p) called the *first focal point*; of course, the converse of this is true. A plane in this point perpendicular to OQ is called the *first focal plane* (A, B). The radius of the refractive surface (m, x) is equal to the difference of the distance of both focal points (p and p_1) from the principal focus (x); thus $m x = p_1 x - p x$. From these comparatively simple propositions it is easy to determine the following points:—

1. **The Construction of the Refracted Ray.**—Let A (Fig. 382) be the first; B , the second medium; c, d , the spherical surface separating the two; a, b , the optical axis; k , the nodal point; p , the first and p_1 the second principal focus; C, D , the second focal plane. Suppose x, y to represent the direction of the incident ray, what is the construction of the refracted ray in the second medium? Prolong the unrefracted ray, P, k, Q parallel to x, y , then y, Q is the direction of the refracted ray (according to 2).

2. **Construction of the Image for a given Object.**—In Fig. 383, B, c, d, a, b, k, p , and p_1, C, D are as before. Suppose a luminous point (o) in the first medium, what is the position of the image in the second medium? Prolong the unrefracted ray (o, k, P), and draw the ray (o, x) parallel to the axis (a, b). The parallel rays (a, e and o, x) reunite in p (according to proposition 1). Prolong x, p_1 until it intersects the ray (o, P), then the image of o is at P , the rays of light ($o x$ and $o k$) proceeding from the luminous point (o) reunite in P .

Construction of the Refracted Ray and the Image in several Refractive Media.—If several refractive media be placed behind each other, we must proceed from medium to medium with the same methods as above described. This would be very tedious, especially when dealing with small objects. Gauss (1840) calculated that, in such cases, the method of construction is

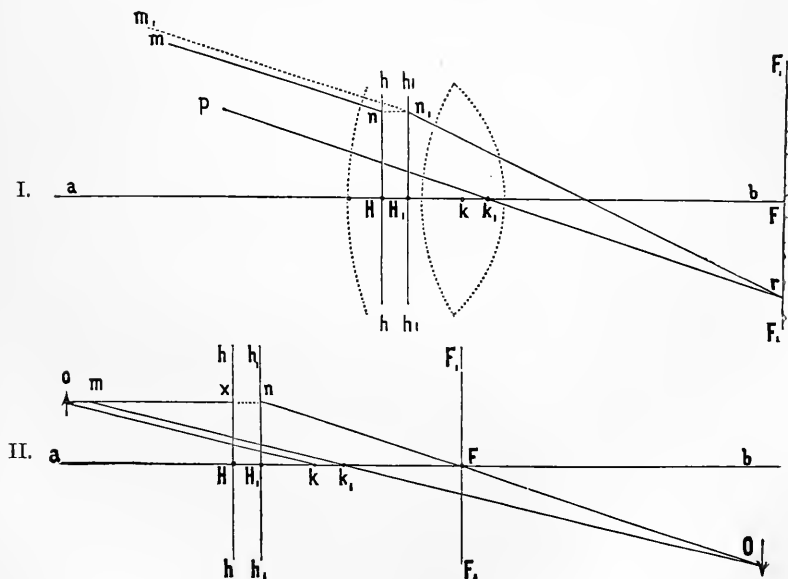

Fig. 384.

very simple. If the several media are “centred”—i.e., if all have the same optic axis, then the refractive indices of such a centred system may be represented by two equal strong refractive surfaces at a certain distance. The rays falling upon

the first surface are not refracted by it, but are essentially projected forwards parallel with themselves to the second surface. Refraction takes place first at the second surface, just as if only *one* refractive surface was present. In order to make the calculation, we must know the refractive indices of the media, the radii of the refractive surfaces, and the distance of the refractive surfaces from each other.

The construction of the refracted ray is accomplished as follows:—Let a, b (Fig. 384, I,) represent the optical axis; H , the first focal point determined by calculation; h, h , the principal plane; H , the second focal point; h_1, h_1 , the second principal plane; k , the first, and k_1 the second nodal point; F , the second focal point; and F_1, F_1 , the second focal plane. Make the ray of direction p, k_1 parallel to m_1, n_1 . According to proposition 2, p, k_1 and m_1, n_1 must meet in a point of the plane F_1, F_1 . As p, k_1 passes through unrefracted, the ray from n_1 must, therefore, fall at r ; n_1, r is, therefore, the direction of the refracted ray.

Construction of the focal point.—Let o (Fig. 384, II) be a luminous point, what is the position of its image in the last medium? Prolong from o the ray of direction o, k , and make o, x parallel to a, b . Both rays are prolonged in a parallel direction to the second focal plane. The ray parallel to a, b goes through F ; m, k_1 as the ray of direction passes through unrefracted. O where n, F and m, k_1 intersect each other, is the position of the image of o .

386. Application of the Dioptric Laws to the Eye —Formation of the Retinal Image—Ophthalmometer.

Position of the Cardinal Points.—The eye surrounded with air on the anterior surface of the cornea, represents a concentric system of refractive media with spherical separating surfaces. In order to ascertain the course of the rays through the various media of the eye, we must know the position of both principal points, both nodal points, as well as the two principal focal points. Gauss, Listing, and v. Helmholtz have calculated the position of these points. In order to make this calculation, we require to know the refractive indices of the media of the eye, the radii of the refractive surfaces, and the distance of the latter from each other. These will be referred to afterwards. The following results were obtained:—

1, The *first principal point* is 2.1746 mm.; and 2, the *second principal point* is 2.5724 mm. behind the anterior surface of the cornea. 3, The *first nodal point*, 0.7580 mm.; and 4, the *second nodal point*, 0.3602 mm. in front of the posterior surface of the lens. 5, The *second principal focus*, 14.6470 mm. behind the posterior surface of the lens; and 6, the *first principal focus*, 12.8326 in front of the anterior surface of the cornea.

Listing's Reduced Eye.—The distance between the two principal points, or the two nodal points, is so small (only 0.4 mm.) that practically without introducing any great error in the construction, we

may assume *one* mean nodal or principal point, lying between the two nodal or principal points. By this simple procedure we gain *one* refractive surface for all the media of the eye, and only *one* nodal point, through which all the rays of direction from without must pass without being refracted. This schematic simplified eye is called "*the reduced eye*" of Listing.

Formation of the Retinal Image.—The construction of the image on the retina thus becomes very simple. In distinct vision the *inverted* image is formed on the retina.

Let *A B* represent an object placed vertically in front of the eye. A pencil of rays passes from *A* into the eye; the ray of direction, *A d*, passes without refraction through the nodal point, *k*. Further, as the focal point for the luminous point, *A*, is upon the retina, all the rays proceeding from *A* must reunite in *d*. The same is true of the rays proceeding from *B*, and, of course, for rays sent out from an intermediate point of the body, *A B*. The retinal image is, as it

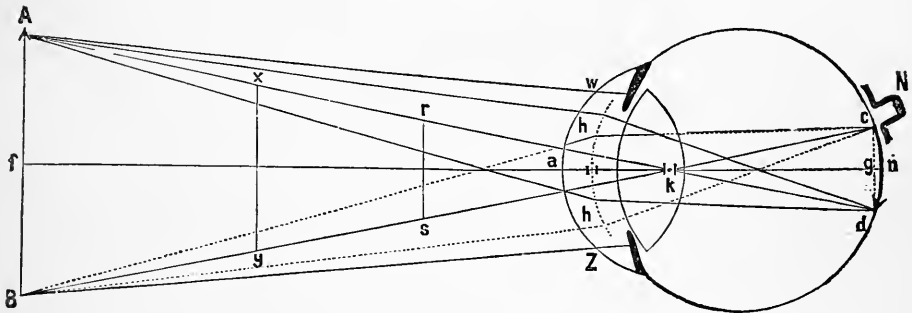

Fig. 385.

were, an endless mosaic of many foci of the object. As all the rays of direction must pass through the combined nodal point, *k*, this is also called the "*point of intersection of the visual rays.*"

The inverted image on the retina is easily seen in an excised eye of an albino rabbit, or in any other eye, by removing a portion of the sclerotic and choroid, and supplying its place with a piece of glass.

The size of the retinal image may also be calculated, provided we know the size of the object and its distance from the cornea. As the two triangles, *A, B, k*, and *c, d, k*, are similar, $A, B : c, d = f, k : k, g$, so that $c, d = (A, B, k, g) : f, k$. All these values are known, viz., $k, g = 15.16$ mm.; further, $f, k = a, k \times a, f$, where a, f is measured directly, and $a, k = 7.44$ mm. The size of *A B* is measured directly.

The angle, *A, k, B*, is called the visual angle, and, of course, it is equal to the angle, *c, k, d*. It is evident that the nearer objects, *x y*, and *r s*, must have the same visual angle. Hence, all the three objects, *A B, x y*, and *r s* give a retinal image of the same size. Such

objects, whose ends when united with the nodal point, form a visual angle of the same size, and consequently form retinal images of the same size, have the same "*apparent size*."

In order to determine the optical cardinal points by calculation after the method of Gauss, we must know the following factors:—

1. *The refractive indices*, which are—for the cornea, 1.377; aqueous humour, 1.377; lens, 1.454 (as the mean value of all the layers); vitreous humour, 1.336; air being taken as 1, and water 1.335 (Chossat, Brewster, Helmholtz, C. and W. Krause, Aubert).

2. *The radii of the spherical refractive surfaces*, which are—of the cornea, 7.7 mm.; of the anterior surface of the lens, 10.3; of the posterior, 6.1 mm.

3. *The distance of the refractive surfaces*—from the vertex of the cornea to the anterior surface of the lens, 3.4 mm.; from the latter to the posterior surface of the lens (axis of the lens), 4 mm.; diameter of the vitreous humour, 14.6 mm. The total length of the optic axis is 22.0 mm.

The Ophthalmometer.—This is an instrument to enable us to measure the radii of the refractive media of the eye. As the normal curvature cannot be accurately measured on the dead eye (Petit, 1723), owing to the rapid collapse of the ocular tunics, we have recourse to the process of Kohlrausch for calculating the radii of the refractive surfaces from the size of the reflected images in the living eye. *The size of a luminous body is to the size of its reflected image, as the distance of both to half the radius of the convex mirror.* Hence, it is necessary to measure the size of the reflected image. This is done by means of the ophthalmometer of Helmholtz (Fig. 386). The apparatus is constructed on the following principle:—If

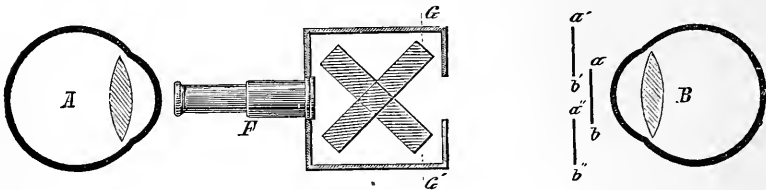

Fig. 386.

Scheme of the ophthalmometer of Helmholtz.

we observe an object through a glass plate placed obliquely, the object appears to be displaced laterally; the displacement becomes greater the more obliquely the plate is placed. Suppose the observer, A, to look through the telescope, F, which has the plate, G, placed obliquely in front of the *upper* half of its objective, he sees the corneal reflected image, a, b , of the eye, B, and the image appears to be displaced laterally, viz., to a', b' . If a second plate, G, be placed in front of the *lower* half of the telescope, but placed in the opposite direction, so that both plates, corresponding to the middle line of the objective, intersect at an angle, then the observer sees the reflected image, a, b , displaced laterally to a'', b'' . As both glass plates rotate round their point of intersection, the position of both is so selected, that both reflected images just touch each other with their inner margins (so that

b' abuts closely upon a''). The size of the reflected image can be determined from the size of the angle formed by both plates, but we must take into calculation the thickness of the glass plates and their refractive indices. The size of the corneal image, and also that in the lens, may be ascertained in the passive eye, and also in the eye accommodated for a near object, and the length of the radius of the curved surface may be calculated therefrom (Helmholtz, Donders, Mauthner, Woinow, Reuss, and others).

Fluorescence.—All the media of the eye, even the retina, are slightly fluorescent; the lens most, the vitreous humour least (v. Helmholtz).

Erect Vision.—As the retinal image is *inverted*, we must explain how we see objects erect. By a *psychical* act, the impulses from any point of the retina are again referred to the exterior, in the direction through the nodal point; thus the stimulation of the point, d (Fig. 385), is referred to A , that of c to B . The reference of the image to the external world happens thus, that all points appear to lie in a surface floating in front of the eye, which is called the *field of vision*. The field of vision is the inverted surface of the retina projected externally; hence the field of vision appears erect again, as the inverted retinal image is again projected externally but inverted.

That the stimulation of any point is again projected in an inverse direction through the nodal point, is proved by the simple experiment that pressure upon the *outer* aspect of the eyeball is projected or referred to the *inner* aspect of the field of vision. The entoptical phenomena of the retina are similarly projected externally and inverted; so that, *e.g.*, the entrance of the optic nerve lies external to the yellow spot (see § 393). All sensations from the retina are projected externally.

387. Accommodation of the Eye.

According to No. 2, p. 967, the rays of light proceeding from a luminous point, *e.g.*, a flame, and acted upon by a collecting (convex) lens, are brought to a focus or focal point, which has always a definite relation to the luminous object. If a projection surface or screen be placed at this distance from the lens, a real and inverted image of the object is obtained upon the screen. If the screen be placed nearer to the lens (Fig. 385, IV., a, b), or farther away from it (c, d), no distinct image of the object is formed, but **diffusion circles** are obtained, because, in the former case, the rays have not united, and in the latter, because the rays, after uniting, have crossed each other and become divergent. If the luminous point be brought nearer to, or removed further from, the lens, in order to obtain a distinct image, in every case the screen must be brought nearer, or removed from, the lens, to keep the same distance between the lens and the screen. If, however, the screen be fixed permanently, whilst the distance between the luminous point and the lens varies, a distinct image can only be obtained upon the screen, provided the lens, as the luminous point approaches it, becomes more convex, *i.e.*, refracts the rays of light more strongly—conversely, when the distance between the luminous point and the lens becomes greater, the lens must become less curved, *i.e.*, refract less strongly.

In the eye, the projection surface, or screen, is represented by the retina, which is permanently fixed at a certain distance; but the eye has the power of forming distinct images of near and distant objects upon the retina, so that the refractive

power, *i.e.*, the form of the crystalline lens in the eye, must undergo a change in curvature corresponding in every case to the distance of the object. [It is important to remember that we cannot see a near object and a distant one with equal distinctness *at the same time*, and hence arises the necessity for accommodation.]

Accommodation.—By the term accommodation of the eye, is understood the property of the eye, whereby it forms distinct images of distant, as well as near objects, upon the retina. This power depends upon the fact that the crystalline lens alters its curvature, becoming more convex (thicker), or less curved (flatter), according to the distance of the object. When the lens is absent from the eyeball, accommodation is impossible (Th. Young, Donders—p. 964).

During rest [or *negative accommodation*], or when the eye is passive, it

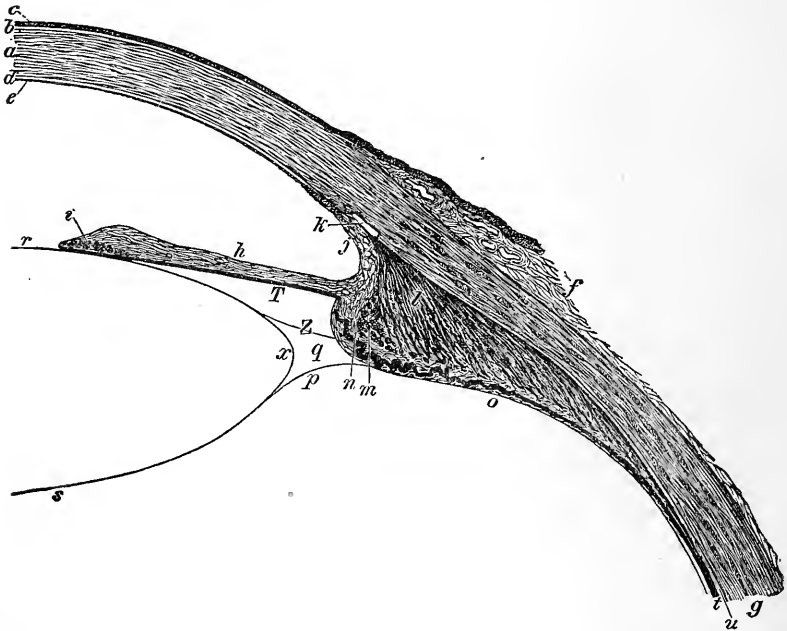

Fig. 387.

Anterior quadrant of a horizontal section of the eyeball, cornea, and lens, divided in the sagittal plane—*a*, substantia propria of the cornea; *b*, Bowman's elastic membrane; *c*, anterior corneal epithelium; *d*, Descemet's membrane; *e*, its epithelium; *f*, conjunctiva; *g*, sclerotic; *h*, iris; *i*, sphincter iridis; *j*, ligamentum pectinatum iridis, with the adjoining vacuolated tissue; *k*, canal of Schlemm; *l*, longitudinal, *m*, circular muscular fibres of the ciliary muscle; *n*, ciliary process; *o*, ciliary part of the retina; *q*, canal of Petit, with *Z*, zonule of Zinn in front of it; and *p*, the posterior layer of the hyaloid membrane; *r*, anterior, *s*, posterior part of the capsule of the lens; *t*, choroid; *u*, perichoroideal space; *T*, pigment epithelium of the iris; *x*, margin of the lens (equator).

is accommodated for the *greatest distance*, *i.e.*, images of objects placed at an infinite distance (*e.g.*, the moon) are formed upon the retina. In this case, rays coming from such a distance are practically *parallel*, and when they enter the eye, are in the *passive normal (emmetropic)* eye, brought to a focus on the retina. When looking at a distant object, a distinct image is formed on the retina without the aid of any muscular action.

That distant objects are seen without the aid of any muscular action is shown by the following considerations:—1. The normal, or emmetropic eye can see distant objects clearly and distinctly without our experiencing any feeling of effort. On opening the eyelids after a long period of rest, the objects at a distance are at once distinctly visible in the field of vision. 2. If, in consequence of paralysis of the mechanism of accommodation (*e.g.*, through paralysis of the oculomotor nerve—§ 345, 7), the eye is unable to focus images of objects placed at different distances; still distinct images are obtained of distant objects. Thus, paralysis of the mechanism of accommodation is always accompanied by inability to focus a near object, never a distant object. A temporary paralysis with the same results, occurs when a solution of atropin or duboisin is dropped into the eye, and also in poisoning with these drugs (§ 392).

When the eye is accommodated for a near object [*positive accommodation*], the lens is thicker, its anterior surface is more curved (convex),

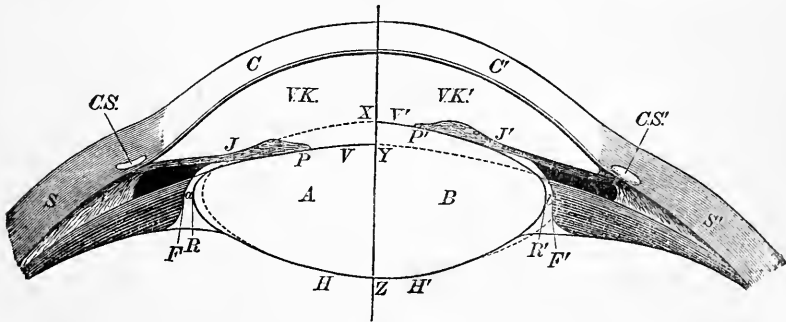

Fig. 388.

Scheme of accommodation for near and distant objects—The right side of the figure represents the condition of the lens during accommodation for a near object, and the left side when the eye is at rest. The letters indicate the same parts on both sides; those on the right side are marked with a stroke; *A*, left, *B*, right half of the lens; *C*, cornea; *S*, sclerotic; *C.S.*, canal of Schlemm; *V.K.*, anterior chamber; *J*, iris; *P*, margin of the pupil; *V*, anterior surface; *H*, posterior surface of the lens; *R*, margin of the lens; *F*, margin of the ciliary processes; *a* and *b*, space between the two former; the line *Z*, *X*, indicates the thickness of the lens during accommodation for a near object; *Z*, *Y*, the thickness of the lens when the eye is passive.

and projects further into the anterior chamber of the eye (Cramer, Helmholtz). The mechanism producing this result is the following:—During *rest*, the lens is kept somewhat flattened against the vitreous

humour lying behind it by the tension of the stretched zonule of Zinn (Fig. 387, Z), which is attached round the margin of the lens. When the muscle of accommodation, the ciliary muscle (*l, m*) contracts, it pulls forward the margin of the choroid, so that the zonule of Zinn in intimate relation with it, is *relaxed*. [When we accommodate for a near object the ciliary muscle contracts, pulls forward the choroid, relaxes the zonule of Zinn, and this, in turn, diminishes the tension of the anterior part of the capsule of the lens.] The lens assumes a more curved form in virtue of its *elasticity*, so that it becomes more convex as soon as the tension of the zonule of Zinn, which keeps it flattened, is diminished (v. Helmholtz). As the posterior surface of the lens lies in the saucer-shaped, unyielding depression of the vitreous humour, the *anterior* surface of the lens in becoming more convex, must necessarily protrude more forwards.

Nerves.—According to Hensen and Völckers, the origin of the nerves of accommodation lies in the most anterior root-bundles of the oculomotorius. Stimulation of the posterior part of the floor of the third ventricle causes accommodation; if a part lying slightly posterior to this be stimulated, contraction of the pupil occurs. On stimulating the limit between the third ventricle and the aqueduct, there results contraction of the internal rectus muscle, while stimulation of the other parts around the *iter* causes contraction of the superior rectus, levator palpebrae, rectus inferior, and inferior oblique muscles.

That the lens undergoes an alteration in its curvature during accommodation is proved by the following facts:—

1. **Purkinje-Sanson's Images.**—If a lighted candle be held at one side of the eye, or if light be allowed to fall on the eye through two triangular holes, placed

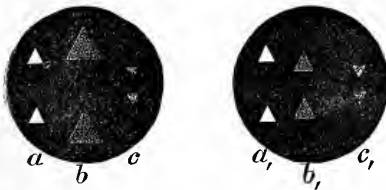

Fig. 389.

Sanson-Purkinje's images—*a, b, c*, during negative, and *a', b', c'*, during positive accommodation.

above each other and cut in a piece of cardboard, the observer will see, in the latter case, three pairs of reflected images [in the former, three images]. The brightest and most distinct image (or pair of images) is erect, and is produced by the anterior surface of the cornea (Fig. 389, *a*). The second image (or pair of images) is also erect. It is the largest, but it is not so bright (*b*), and it is reflected by the anterior surface of the lens. (The size of a reflected image from a convex mirror is greater, the longer the radius of curvature of the reflecting surface.) The latter image lies 8 mm. *behind* the plane of the pupil. The third image (or pair of images) is of medium size and medium brightness—it is *inverted* and lies nearly in the plane of the pupil (*c*). The posterior capsule of the lens, which reflects the last image, acts like a concave mirror. If a luminous object be placed at a distance from a concave mirror, its inverted, diminished *real* image lies close to the focus

towards the side of the object. If the images be studied when the observed eye is passive, *i.e.*, in the phase of negative accommodation, on asking the person experimented upon to accommodate his eye for a near object, at once a change in the relative position and size of some of the images is apparent. The middle pair of images, reflected by the anterior surface of the lens, diminish in size and approach each other (b_1), which depends upon the fact that the anterior surface of the lens has become more convex. At the same time the image (or pair of images) comes nearer to the image formed by the cornea (a , and c), as the anterior surface of the lens lies nearer to the cornea. The other images (or pairs of images) neither change their size nor position. v. Helmholtz, with the aid of the ophthalmometer, has measured the diminution of the radius of curvature of the anterior surface of the lens during accommodation for a near object.

[Phakoscope.—These images may be readily shown by means of the phakoscope of v. Helmholtz (Fig. 390). It consists of a triangular box blackened inside and with its angles cut off. The observer's eye is placed at a , while on the opposite side of the box are two prisms b, b_1 , the observed eye is placed at the side of the box opposite to C . When a candle is held in front of the prisms, b and b_1 , three pairs of images are seen in the observed eye. Ask the person to accommodate for a distant object, and note the position of the images. On pushing up the slide C with a pin attached to it, and asking him to accommodate for the pin, *i.e.*, for a near object, the position and size of the middle images chiefly will be seen to alter as described above.]

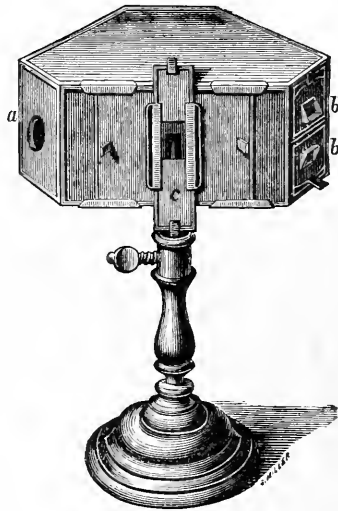

Fig. 390.

Phakoscope of Helmholtz (after M'Kendrick).

2. In consequence of the increased curvature of the lens during accommodation for a near object, the refractive indices within the eye must undergo a change. According to v. Helmholtz the following measurements obtain in negative and positive accommodation respectively:—

Accommodation.	Negative—Mm.	Positive—Mm.
Radius of the cornea,	8	8
Radius of anterior surface of lens,	10	6
Radius of posterior surface of lens,	6	5.5
Position of the vertex of the outer surface of the } lens behind the vertex of the cornea, . . . }	3.6	3.2
Position of the posterior vertex of the lens, . . .	7.2	7.2
Position of the anterior focal point,	12.9	11.24
Position of the first principal point,	1.94	2.03
Position of the second principal point,	6.96	6.51
Position of the posterior focal point behind the } anterior vertex of the cornea, }	22.23	20.25

3. **Lateral View of the Pupil.**—If the passive eye be looked at from the side, we observe only a small black strip of the pupil, which becomes broader as soon as the person experimented on accommodates for a near object, as the whole pupil is pushed more forwards.

4. **Focal Line.**—If light be admitted through the cornea into the anterior chamber, the "focal line" formed by the concave surface of the cornea, falls upon the iris. If the experiment be made upon a person whose eye is accommodated for a distant object, so that the line lies near the margin of the pupil, it gradually recedes towards the scleral margin of the iris, as soon as the person accommodates for a near object, because the iris becomes more oblique, as its inner margin is pushed forward.

5. **Change in Size of Pupil.**—On accommodating for a near object the *pupil* contracts, while, in accommodation for a distant object, it dilates (Descartes, 1637). The contraction takes place slightly after the accommodation (Donders). This phenomenon may be regarded as an associated movement, as both the ciliary muscle and the sphincter pupillæ are supplied by the oculomotorius (§ 345, 2, 3). A reference to fig. 387 shows that the latter also directly supports the ciliary muscle; as the inner margin of the iris passes inwards (towards *r*), its tension tends to be propagated to the ciliary margin of the choroid, which also must pass inwards. The ciliary processes are made tense, chiefly by the ciliary muscle (tensor choroideæ). Accommodation can still be performed, even though the iris be absent or cleft.

6. **Internal Rotation of the Eye.**—On rotating the eyeball inwards, accommodation for a near object is performed involuntarily. As rotation of both eyeballs inwards takes place, when the axes of vision are directed to a *near* object, it is evident that this must be accompanied involuntarily by an accommodation of the eye for a near object.

7. **Time for Accommodation.**—A person can accommodate from a near to a distant object (which depends upon relaxation of the ciliary muscle) much more rapidly, than conversely, from a distant to a near object (Vierordt, Aeby). The process of accommodation requires a longer time, the nearer the object is brought to the eye (Vierordt, Völckers and Hensen). The time necessary for the image reflected from the anterior surface of the lens, to change its place during accommodation, is less than that required for subjective accommodation (Aubert and Angelucci).

8. **Line of Accommodation.**—When the eye is placed in a certain position during accommodation, we may see not *one* point alone distinctly, but a whole series of points behind each other. Czermak called the line in which these points lie, the *line of accommodation*. The more the eye is accommodated for a distant object the longer this line becomes. All objects placed at a greater distance from the eye than 60–70 metres, appear equally distinct to the eye. The line becomes shorter the more we accommodate for a near object—*i.e.*, when we accommodate as much as possible for a near object, a second point can only be seen indistinctly at a *short* distance behind the object looked at.

9. The **nerves** concerned in the mechanism of accommodation are referred to under *Oculomotorius* (§ 345, and again in § 704).

Scheiner's Experiment.—The experiment which bears the name of Scheiner (1619), serves to illustrate the refractive action of the lens during accommodation for a near object, as well as for a distant object. Make two small pin-holes (*S*, *d*) in a cardboard (Fig. 391, K, K_1), the holes being nearer to each other than the diameter of the pupil. On looking through these holes, *S*, *d*, at two needles (*p* and *r*) placed behind

each other, then on accommodating for the *near* needle (p), the far needle (r) becomes double and inverted. On accommodating for the near needle (p), of course the rays proceeding from it fall upon the retina at the focus (p_1); while the rays coming from the far needle (r) have *already* united and crossed in the vitreous humour, whence they diverge more and more and form two pictures (r, r'') on the retina. If the *right* hole in the cardboard (d) be closed, the *left* picture on the retina (r'') of the double images of the far needle disappears. An analogous result is obtained on accommodating for the far needle (R). The near needle (P) gives a double image (P, P''), because the rays from it have not yet come to a focus. On closing the *right* hole (d), the *right* double image (P'') disappears (Porterfield). When the eye of the observer is accommodated for the *near* needle, on closing one aperture, the double image of the distant point disappears on that side; but if the eye is accommodated for the *distant* needle, on closing one hole, the crossed image of the near needle disappears.

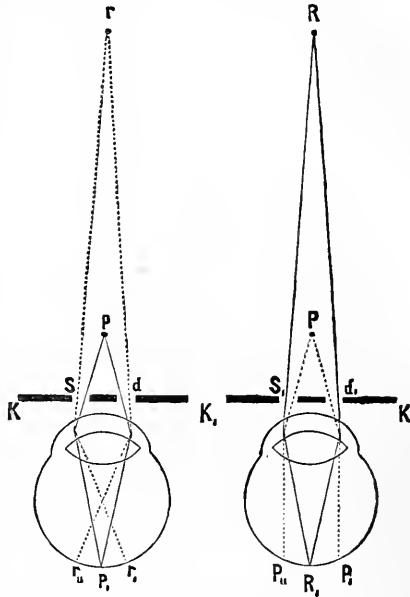

Fig. 391.

Scheiner's experiment.

388. The Refractive Power of the Normal Eye— Anomalies of Refraction.

Far Point—Near Point.—The limits of distinct vision vary very greatly in different eyes. We distinguish the *far point* [*p. r.*, *punctum remotum*] and the *near point* [*p. p.*, *punctum proximum*]; the former indicates the distance to which an object may be removed from the eye, and may still be seen distinctly; the latter, the distance to which any object may be brought to the eye, and may still be seen distinctly. The distance between these two points is called the *range of accommodation*. The types of eyeball are characterised as follows—

1. The normal or emmetropic eye is so arranged when at rest, that parallel rays (Fig. 392, r, r') coming from the most distant objects can be focussed on the retina (r). The far point, therefore, is $= \infty$ (infinity). When accommodating as much as possible for a near object, whereby

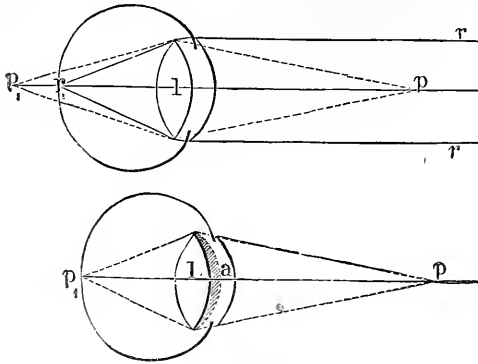

Fig. 392.

Condition of refraction in the normal passive eye and during accommodation.

the convexity of the lens is increased (Fig. 392, a), rays from a luminous point placed at a distance of 5 inches are still focussed on the retina, i.e., the near point is $= 5$ inches (1 inch $= 27$ mm.). The range of accommodation, or ["the range of distinct vision"], therefore, is from 5 inches (10-12 cm.) to ∞ .

2. The short-sighted (myopic or long) eye

(Fig. 393) cannot, when at rest, bring parallel rays from infinity to a focus on the retina. These rays decussate within the vitreous humour (at O), and, after crossing, form a diffusion circle upon the retina. The object must be removed from the passive eye to a distance of 60-120 inches (to f), in order that the rays may be focussed on the retina. The passive myopic eye, therefore, can only focus divergent rays upon the retina. The far point, therefore, lies abnormally near. With an intense effort at accommodation, objects at a distance of 4 to 2 inches, or even less, from the eye, may be seen distinctly. The near point, therefore, lies abnormally near; the range of accommodation is diminished.

Short-sightedness, or myopia, usually depends upon congenital, and frequently hereditary, elongation of the eyeball. This anomaly of the refractive media is easily corrected by using a diverging lens (concave), which makes par-

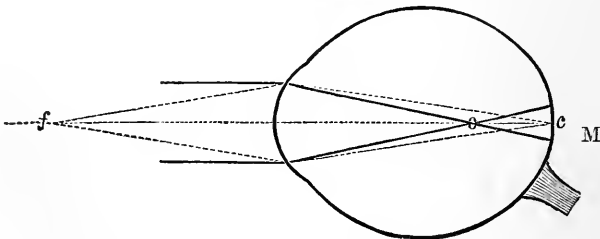

Fig. 393.

Myopic Eye.

allel rays divergent, so that they can then be brought to a focus on the retina. It is remarkable that most children are myopic when they are born. This myopia, however, depends upon a too-curved condition of the cornea and lens, and on the

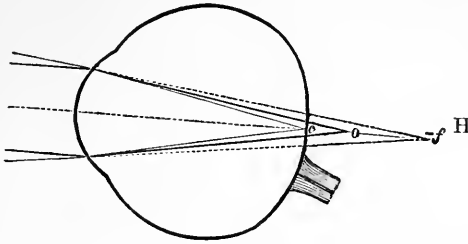

Fig. 394.

Anomalies of the refractive media in a myopic (Fig. 393), and a hypermetropic eye (Fig. 394).

lens being too near to the cornea. As the eye grows, this short-sightedness disappears. The cause of myopia in children is ascribed to the continued activity of the ciliary muscle in reading, writing, &c., or the continued convergence of the eyeballs, whereby the external pressure upon the eyeball is increased.

3. The long-sighted eye (Fig. 394) hypermetropic, hyperopic, (flat eye) when at *rest*, can only cause convergent rays to come to a focus on the retina. Distinct images can only be formed when the rays, proceeding from objects, are rendered convergent by means of a convex lens, as parallel rays would come to a focus behind the retina (at f). All rays proceeding from natural objects are either divergent, or at most, nearly parallel, never convergent. Hence it follows that no long-sighted person, when the eye is *passive*—*i.e.*, is *negatively* accommodated, can see distinctly without a convex lens. When the ciliary muscle contracts, slightly convergent, parallel, and even slightly divergent rays may be focussed, according to the increasing degree of the accommodation. The *far point* of the eye is negative, the *near point* abnormally distant (over 8 to 80 inches), while the *range of accommodation* is infinitely great.

[Defective Accommodation.—In the presbyopic eye, or long-sighted eye of old people, the near point is further away than normal, but the far point is still unaffected. In such cases the person cannot see a near object distinctly, unless it be held at a considerable distance from the eye. It is due to a defect in the mechanism of accommodation, the lens becoming somewhat flatter, less elastic, and denser with old age, while the ciliary muscle becomes weaker. In hypermetropia, on the contrary, the mechanism of accommodation may be perfect, yet from the shape of the eye the person cannot focus, on his retina, the rays of light from a near object. In presbyopia the range of distinct

vision is diminished. The defect is remedied by weak *convex* glasses. The defect usually begins about forty-five years of age.]

The **cause** of hypermetropia is abnormal shortness of the eye, which is generally due to imperfect development in all directions. It is corrected by using a *convex lens*.

Estimation of the Far Point.—In order to determine the *far point* of an eye, gradually bring nearer to the eye objects which form a visual angle of five minutes (*e.g.*, Snellen's small type letters, or the *medium* type, 4-8, of Jaeger), until they can be seen distinctly. The distance from the eye indicates the far point. In order to determine the far point of a *myopic* person, place at 20 inches distant from the eye, the same objects which give a visual angle of five minutes, and ascertain the *concave lens* which will enable the person to see the objects distinctly. To estimate the *near point*, bring small objects (*e.g.*, the finest print), nearer and nearer to the eye, until it finally becomes indistinct. The distance at which one can still see distinctly indicates the far point.

Optometer.—The optometer may also be used to determine the *near* and *far points*. A small object, *e.g.*, a needle, is so arranged as to be movable along a scale, along which the eye to be investigated can look, as a person looks along the sight of a rifle. The needle is moved as near as possible, and then removed as far as possible, in each case as long as it is seen distinctly. The distance of the near and far point, and the range of accommodation can be read off directly upon the scale (Gräfe).

389. The Power or Force of Accommodation.

Force of Accommodation.—The range of accommodation, which is easily determined experimentally, does not by itself determine the proper *power* or *force* of accommodation. The measure of the latter depends upon the *mechanical work* done by the muscle of accommodation, or the ciliary muscle. Of course this cannot be directly determined in the eye itself. Hence this force is measured by the *optical effect*, which results in consequence of the change in the shape of the lens, brought about by the energy of the contracting muscle.

In the *normal eye*, during the passive condition, the rays coming from infinity, and therefore parallel (which are dotted in Fig. 395), are focussed upon the retina at *f*. If rays coming from a distance of 5 inches (p. 985) are to be focussed, the whole available energy of the ciliary muscle must be brought into play to allow the lens to become more convex, so that the rays may be brought to a focus at *f*. The energy of accommodation, therefore, produces an *optical effect* in as far as it increases the convexity of the anterior surface of the passive lens (A), by the amount indicated by B. Practically, we may regard the matter as if a new convex lens (B) were added to the existing convex lens (A). What, therefore, must be the focal distance of the lens (B), in order that rays coming from the near point (5 inches) may be focussed upon the retina at *f*? Evidently, the lens B must make the

diverging rays coming from p , parallel, and then A can focus them at f . Convex lenses cause those rays proceeding from their *focal points* to pass out at the other side as parallel rays (§ 385, 1). In our case, therefore, the lens must have a focal distance of 5 inches. The normal eye, therefore, with the far point = ∞ , and the near point = 5 inches, has a power of accommodation equal to a lens of 5 inches focal distance. When the lens by the energy of accommodation is

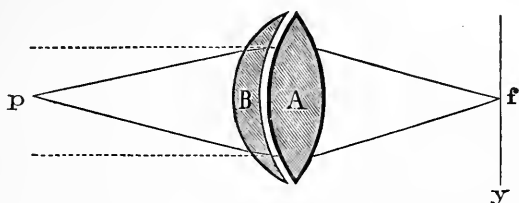

Fig. 395.

rendered more powerfully refractive, the increase (B) can readily be eliminated by placing before the eye a *concave lens* which possesses exactly the opposite optical effect of the increase of accommodation (B). Hence, it follows that it is possible to indicate the power (force) of accommodation of the eye by a lens of a definite focal distance, *i.e.*, by the optical effect produced by the latter. Therefore, according to Donders, the measure of the force of accommodation of the eye is the reciprocal value of the focal distance of a concave lens, which when placed before the accommodated eye, so refracts the rays of light coming from the near point (p) as if they came from the far point.

Example.—We may calculate the force of the accommodation according to the following formula: $\frac{1}{x} = \frac{1}{p} - \frac{1}{r}$, *i.e.*, the force of accommodation, expressed as the dioptric value of a lens (of x inch focal distance), is equal to the difference of the reciprocal values of the distances of the near point (p) and of the far point (r) of the eye. In the *emmetropic* eye, as already mentioned, $p=5$, $r=\infty$. Its force of accommodation is, therefore, $\frac{1}{x} = \frac{1}{p} - \frac{1}{\infty}$, so that $x=5$, *i.e.*, it is equal to a lens of 5 inches focal distance. In a *myopic* eye, $p=4$, $r=12$, so that $\frac{1}{x} = \frac{1}{4} - \frac{1}{12}$, *i.e.*, $x=6$. In another myopic eye, with $p=4$ and $r=20$, then $x=5$, which is a normal force of accommodation. Hence, it is evident that two different eyes, possessing a very different *range* of accommodation, may nevertheless have the same *force* of accommodation. **Example.**—The one eye has $p=4$, $r=\infty$, the other, $p=2$, $r=4$. In both cases, $\frac{1}{x} = \frac{1}{4}$, so that the force of accommodation of both eyes is equal to the dioptric value of a lens of 4 inches focal distance. Conversely, two eyes may have the same range of accommodation, and yet their force of accommodation be very unequal. **Example.**—The one eye has $p=3$, $r=6$; the other, $p=6$,

$r=9$. Both, therefore, have a range of accommodation of 3 inches. For these, the force of accommodation, $\frac{1}{x} = \frac{1}{3} - \frac{1}{6}$, $x=6$; and $\frac{1}{x} = \frac{1}{6} - \frac{1}{9}$, $x=18$.

Relation of the range of accommodation to the force of accommodation. The general law is, that the ranges of accommodation of two eyes being equally great, then their forces of accommodation are equal, provided that their near points are the same. If the ranges of accommodation for both eyes are equally great, but their near points unequal, then the forces of accommodation are also unequal—the latter being greater in the eyes with the smallest near point. This is due to the fact that every difference of distance near a lens has a much greater effect upon the image, compared with differences in the distance far from a lens. The emmetropic eye can see distinctly objects at 60–70 metres, and even to infinity, without accommodation.

While p and r may be directly estimated in the emmetropic and myopic eyes, this is impossible with the hypermetropic (long-sighted) eye. The far point in the latter is negative, indeed, in very pronounced hypermetropia, even the near point may be negative. The far point may be estimated by making the hypermetropic eye practically a normal eye, by using suitable convex lenses. The relative near point may then be determined by means of the lens.

Even from the 15th year onwards, the power of accommodation is generally diminished for near objects—perhaps this is due to a diminution of the elasticity of the lens (Donders).

390. Spectacles.

The focal distance of concave (diverging), as well as convex (converging) spectacles, depends upon the refractive index of the glass (usually 3 : 2), and on the length of the radius of curvature. If the curvature of both sides of the lens is the same (biconcave or biconvex), then, with the ordinary refractive index of glass, the focal distance is the same as the radius of curvature. If one surface of the lens is plane, then the focal distance is twice as great as the radius of the spherical surface. Spectacles are arranged according to their focal distance in inches, but a lens of shorter focal distance than 1 inch is generally not used. They may also be arranged according to their refractive power. In this case, the refractive power of a lens of 1 inch focus is taken as the unit. A lens of 2 inches focus refracts light only half as much as the unit measure of 1 inch focus; a lens of 3 inches focus refracts $\frac{1}{3}$ as strongly, &c. This is the case both with convex and concave lenses, the latter, of course, having a negative focal distance; thus, "concave— $\frac{1}{8}$," indicates that a concave lens diverges the rays of light one-eighth as strongly as the concave lens of 1 inch (negative) focal distance.

Choice of Spectacles.—Having determined the near point in a myopic eye, of course we require to render parallel the divergent rays coming from the far point, just as if they came from infinity. This is done by selecting a concave lens of the focal distance of the far point. The greatest distance is the far point of the emmetropic eye. Suppose a myopic eye with a far point of 6 inches, then such a person requires a concave lens of 6 inches focus to enable him to see distinctly at the greatest distance. Thus, in a myopic eye, the distance of the far point from the eye is directly equal to the focus of the (weakest) concave lens, which enables one to see distinctly objects at the greatest distance. These lenses generally have the same number as the spectacles required to correct the defect. **Example.**—A myopic eye with a far point of 8 inches requires a concave lens of 8 inches focus, i.e., the concave spectacles No. 8. For the hypermetropic (long-sighted) eye, the focal distance of the strongest convex lens, which enables the hypermetropic eye to

see the most distant objects distinctly, is at the same time the distance of the far point from the eye. **Example.**—A hypermetropic eye which can see the most distant objects with the aid of a *convex* lens of 12 inches focus has a far point of 12; the proper spectacles is convex No. 12.

[Dioptric.—The focal length of a lens used to be expressed in inches, and as the unit was taken as 1 inch, necessarily all weaker lenses were expressed in fractions of an inch. In the method advocated by Donders, the standard is a lens of a focal distance of 1 metre (33·337 English inches, about 40 inches), and this unit is called a *dioptric*. Thus the standard is a weak lens, so that the stronger lenses are multiples of this. Thus a lens of 2 dioptrics is = one of about 20 inches focus; 10 dioptrics = 4 inches focus; and so on. The lenses are numbered from No. 1, *i.e.*, 1 dioptric onwards.]

[It is convenient to use signs instead of the words convex and concave. For convex the sign *plus* + is used, and for concave the sign *minus* -. Thus a + 4·0 means a convex lens of 4 dioptrics, and a - 4·0 = a concave lens of 4 dioptrics.]

In all cases of myopia or hypermetropia, the person ought to wear the proper spectacles. In a *myopic* eye, when the far point is still more than 5 inches, the patient ought always to wear spectacles; but generally the working distance, *e.g.*, for reading, writing, and for handicrafts is about 12 inches from the eye. If the person desires to do finer work (etching, drawing), requiring the object to be brought nearer to the eye, so as to obtain a larger image upon the retina, then he should either remove the spectacles altogether, or use a weaker pair.

The *hypermetropic* person ought to wear his convex spectacles when looking at a near object, and especially when the illumination is feeble, because then, owing to the dilatation of the pupil, the diffusion circles of the eye tend to become very pronounced. It is advisable to wear at first convex spectacles, which are slightly too strong. **Cylindrical lenses** are referred to under *Astigmatism*. Spectacles provided with dull-coloured or blue glasses are used to protect the retina, when the light is too intense. **Stenopaic spectacles** are narrow diaphragms placed in front of the eye, which cause it to move in a definite direction, in order to see through the opening of the diaphragm.

391. Chromatic and Spherical Aberration— Astigmatism.

Chromatic Aberration in the Eye.—All the rays of *white* light, which undergo refraction, are at the same time broken up by dispersion into a bundle of rays which, when they are received on a screen, form a spectrum. This is due to the fact that the different colours of the spectrum possess different degrees of refrangibility. The violet rays are refracted most strongly; the red rays least.

A white point on a black ground does not form a sharp, simple image on the retina, but many coloured points appear after each other. If the eye is accommodated so strongly as to focus the violet rays to a sharp image, then all the other colours must form concentric diffusion circles, which become larger towards the red. In the centre of all the circles, where all the colours of the spectrum are superposed, a white point is produced by their mixture, while around it are placed the coloured circles. The distance of the focus of the red rays from that of the violet in the eye = 0·58 - 0·62 mm. The focal distance for red is, according to v. Helmholtz, for the reduced eye, 20·524 mm.; for violet, 20·140 mm. Hence,

the near and far points for violet light are nearer each other than in the case of red light; white objects, therefore, appear reddish when beyond the far point, but when nearer than the near point, they are violet. Hence, the eye must accommodate more strongly for red rays than for violet, so that we judge red objects to be nearer us than violet objects placed at an equal distance (Brücke).

Monochromatic, or Spherical Aberration.—Apart from the decomposition or dispersion of white light into its components, the rays of white light, proceeding from a point if transmitted through refractive spherical surfaces, we find that, before the rays are again brought to a focus, the *marginal* rays are more strongly refracted than those passing through the central parts of the lens. Hence, there is not *one* focus, but many. In the eye this defect is naturally corrected by the *iris*, which, acting as a diaphragm, cuts off the marginal rays (Fig. 385), especially when the lens is most convex, when the pupil also is most contracted. In addition, the margin of the lens has less refractive power than the central substance; lastly, the margins of the refractive spherical surfaces of the eye, are less curved towards their margins, than the parts lying nearer to the optical axis. Compare the form of the *cornea* (p. 955), and the lens (p. 963).

Imperfect Centering of the Refractive Surfaces.—The sharp projection of an image is somewhat interfered with, by the fact that the refractive surfaces are not exactly centred (Brücke). Thus, the vertex of the cornea is not exactly in the termination of the optic axis; the vertices of both surfaces of the lens and even the different layers of the lens itself, are not exactly in the optic axis. The variations, however, and the disturbances produced thereby, are very small indeed.

Regular Astigmatism.—When the curvature of the refractive surfaces of the eye is unequally great in its different meridians, of course the rays of light cannot be united or focussed in one point. Generally, in such cases, the cornea is more curved in its vertical meridian, and least in the horizontal (as is shown by ophthalmometric measurements, p. 974). The rays passing through the vertical meridian come to a focus, *first*, in a horizontal focal line; while the rays entering horizontally, unite afterwards in a vertical line. There is thus no common focus for the light rays in the eye; hence the name astigmatism. The lens also is unequally curved in its meridians, but it is the reverse of the cornea; consequently, a part of the inequality of the curvature of the cornea is thereby compensated, and only a part of it affects the rays of light. The emmetropic eye has a *very slight* degree of this inequality (normal astigmatism). If two very fine lines of equal thickness be drawn on white paper, so as to intersect each other at right angles, it will be found that, in order to see the horizontal line quite sharply, the paper must be brought slightly nearer to the eye than when we focus the vertical line. When the inequality of curvature of the meridians is considerable, of course exact vision is no longer possible.

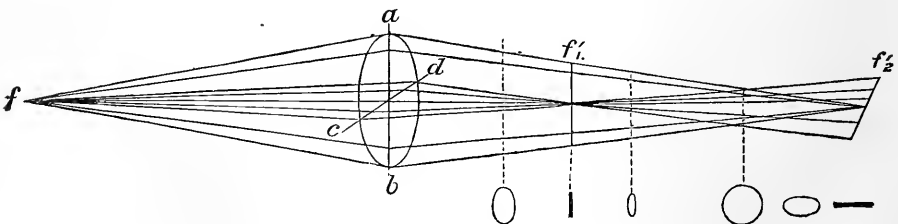

Fig. 396.

Action of an astigmatic surface on a cone of light (Pickard and Curry, after Donders).

[Fig. 396 shows the effect of an astigmatic surface on the rays of light. Let $abcd$ be such a surface, and suppose diverging rays to proceed from f . The rays passing through cd come to a focus at f_1 , while those passing through the vertical meridian are focussed at f_2 . The outline of the cone of rays between $abcd$ and f_2 varies, as shown in the figure. At a certain part it is oval, with its axis vertical, at another the long axis of the oval is horizontal, while at other places it is circular, or the rays are focussed in a horizontal or vertical line.]

Correction.—This condition is corrected by a *cylindrical lens*, *i.e.*, a lens so cut as to be without curvature in one direction, while in the other direction (vertical to the former) it is curved. The lens is placed in front of the eye, so that the direction of its curvature coincides with the direction of least curvature of the eye (v. Helmholtz, Knapp, Donders). The section $Cabcd$ of the cylindrical lens (Fig. 397) represents a plano-convex, the section $Ca\beta\gamma\delta$, a concavo-convex lens.

[Test.]—Draw two lines of equal thickness at right angles to each other. An astigmatic person cannot see both lines with equal distinctness at the same time, one line will appear thicker than the other. Or a series of lines radiating from a centre may be used; when that line which is parallel to the astigmatic meridian will be seen most distinctly; while, with the vertical meridian most curved, it would be the vertical line.]

Irregular Astigmatism.—Owing to the radiate arrangement of the fibres in the interior of the crystalline lens, and in consequence of the unequal course of the fibres within the different parts of one and the same meridian of the lens, the rays of light passing through one meridian of the lens, cannot all be brought to one focus. Hence we do not obtain a distinct sharp image of distant, luminous points, such as stars or street-lamps, but we see a radiate, jagged figure provided with rays. The same obtains on holding a piece of cardboard, with a small hole in it, towards the light, at a distance from the eye slightly greater than the far point. Slight degrees of this irregular astigmatism are normal, but when it is highly developed, it greatly interferes with vision, by forming several foci of an object, instead of one (*Polyopia monocularis*). Of course, this condition cannot obtain in an eye devoid of a lens.

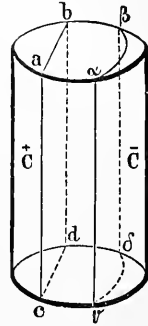

Fig. 397.

Cylindrical glasses for astigmatism.

392. The Iris.

Functions.—1. The iris acts like a diaphragm of an optical apparatus, by cutting off the marginal rays (Fig. 385, p. 973), which, if they entered the eye, would cause *spherical aberration*, and thus produce indistinct vision.

2. As the pupil contracts strongly in a bright light, and dilates when the light is feeble, it *regulates* the amount of light entering the eye; thus fewer rays enter the eye when the light is strong, than when it is feeble.

3. To a certain extent it supports the action of the ciliary muscle.

Muscles and Nerves.—The iris is provided with *two sets of muscular fibres*—the *sphincter*, which immediately surrounds the pupil (p. 959), and is supplied by the oculomotorius (§ 345, 2), and the *dilator pupillæ*

(p. 959), supplied chiefly by the cervical sympathetic (§ 356, A, 1), and the trigeminus (p. 793, 3). Both muscles stand in an *antagonistic* relation to each other (p. 676); hence the pupil dilates after section or paralysis of the oculomotorius (p. 676), owing to the contraction of the dilator fibres which are supplied by the cervical sympathetic; conversely, the pupil contracts when the sympathetic is divided or extirpated (Petit, 1727). When both nerves are stimulated simultaneously, the pupil contracts, so that the excitability of the oculomotorius overcomes the sympathetic.

Nerves.—Arnstein and A. Meyer have studied the mode of termination of the nerve-fibres in the iris. All the medullated nerve-fibres lose their white sheaths after a time; most of the fibres (*motor*) in the region of the sphincter consist of naked bundles of fibrils. A net-work of very delicate *sensory* nerves lies under the anterior epithelium. Numerous fibrils pass to the capillaries and arteries as *vaso-motor nerves*. [Many ganglionic cells are intercalated in the course of the fibres.]

Movements of the iris occur under the following conditions:—

1. **Action of light on the retina** causes (according to its intensity and amount) a corresponding contraction of the pupil; the same effect is produced by *stimulation of the optic nerve itself* (Herbert Mayo, †1852). This movement is a reflex act, [the *afferent* nerve being the optic, and the *efferent* the oculomotorius; the impulse is transferred from the former to the latter in a centre situated somewhere below the corpora quadrigemina (Fig. 398, C)].

The older observers locate the centre in the corpora quadrigemina, the recent observers in the medulla oblongata (p. 940). *Both* pupils always react, although only one retina be stimulated, generally under normal circumstances both contract to the same extent (Donders), owing to the intercentral communication [coupling] of the two pupillo-constricting centres. [This is called consensual contraction of the pupil.] After section of the optic nerve the pupil dilates, and subsequent section of the oculomotorius no longer produces any further dilatation (Knoll).

2. **The centre for the dilator fibres of the pupil** (pupillo-dilating centre) is excited by *dyspnoic blood* (§ 367, 8). If the dyspnoea ultimately passes into asphyxia, the dilatation of the pupil diminishes. Of course, if the peripheral dilating fibres (p. 793, 3) [*e.g.*, the sympathetic nerve in the neck] be previously divided, this effect cannot take place, as the dyspnoic blood acts on the *centre*, and not on the nerve-fibres.

3. The **centre**, as well as the subordinate "*ciliospinal region*" of the spinal cord (§ 362, 1), is also capable of being excited *reflexly*; painful stimulation of sensory nerves, in addition to causing protrusion of the eyeballs (p. 795), a fact proved in the case of persons subjected to torture, produces dilatation of the pupils (Arndt, Bernard, Westphal, Luchsinger); while a similar effect is caused by labour pains, a loud call in the ear, stimulation of the nerves of the sexual organs, and even by slight tactile impressions (Foà and Schiff). According to Bechterew, the foregoing results are due to inhibition of the light-reflex in the sense expressed in § 361, 3.

4. The **condition of the blood-vessels** of the iris influences the size of the pupil; all conditions causing injection or congestion of these vessels contract the pupil, all conditions diminishing them dilate it. The pupil, therefore, is *contracted* by *forced expiration*, which prevents the return of venous blood from the head, momentarily by every *pulse-beat*, owing to the diastolic filling of the

arteries; *diminution of the intraocular pressure*—*e.g.*, after puncture of the anterior chamber, because, owing to the diminished intraocular pressure, there is less resistance to the passage of blood into the blood-vessels of the iris (Hensen and Völckers); paralysis of the vaso-motor fibres of the iris (p. 793, 2). Conversely, the pupil is *dilated* by conditions the reverse of those already mentioned, and also by *strong muscular exertion*, whereby blood flows freely into the dilated muscular blood-vessels; also when death takes place. The condition of the filling of the blood-vessels also explains the fact, that the pupil dilated with atropin becomes smaller when a part of the sympathetic in the upper cervical ganglion, carrying the vaso-motor fibres of the iris, is excised; also that after extirpation of this ganglion, atropin always causes a less diminution of the pupil on this side. The fact that when the pupil is already dilated by stimulation of the sympathetic, it is further dilated by atropin, is due to a diminished injection of the blood-vessels of the iris. If an animal with its pupils dilated with atropin be rapidly bled, the pupils contract, owing to the anæmic stimulation of the origin of the oculomotorius (Moriggia). The dilatation of the pupils observed in cases of neuralgia of the trigeminus is partly due to the stimulation of the dilating fibres (p. 793, 3), partly to the stimulation of the vaso-motor fibres of the iris (p. 793, 2).

5. Contraction of the pupil occurs as an **associated movement** during *accommodation* for a near object (p. 980, 5), and when the *eyeballs are rotated inwards*, which is the case during *sleep* (p. 909). Conversely, intense movements of the iris, caused by variations in the brightness of dazzling illumination—*e.g.*, of the electric light—are followed by disturbing associated movements of the ciliary muscle (Ljubinsky). In certain movements discharged from the medulla oblongata (forced respiration, chewing, swallowing, vomiting), dilatation of the pupil occurs as a kind of *associated movement*.

[Argyll Robertson Pupil.—In this condition, the pupil does not contract to light, although it contracts when the eye is accommodated for a near object, vision usually being normal. The lesion is situated in those structures connecting the afferent and efferent fibres at their central ends (at Δ in Fig. 398), *i.e.*, the connection between the corpora quadrigemina and the oculomotorius. It is most frequently found in locomotor ataxia, although it also occurs in progressive paralysis of the insane.]

Direct stimulation at the margin of the cornea causes dilatation of the pupil (E. H. Weber); in fact, direct stimulation of circumscribed areas of the margin of the iris causes partial contraction of the dilator fibres (Bernstein and Dogiel). Stimulation nearer the centre of the cornea contracts the pupil (E. H. Weber). In addition, we must assume that the iris itself contains elements that influence the diameter of the pupil (Sig. Mayer and Pribram).

Our knowledge of the **action of poisons** on the iris is still very obscure. Those substances which dilate the pupil are called **mydriatics**—*e.g.*, atropin, homatropin, duboisin (Tweedy, v. Hasner), daturin, and hyoscyamin. They act chiefly by paralyzing the oculomotorius. But, in addition, there must be also an effect upon the dilating fibres, for, after complete paralysis (section) of the oculomotorius, the *moderate* dilatation of the pupil thereby produced (§ 345, 5) is still further increased by atropin. *Minimal doses* of atropin contract the pupil, owing to stimulation of the pupillo-constrictor fibres; *enormous* doses cause moderate dilatation of the pupil in consequence of paralysis of the dilating, as well as of the constricting nerve-fibres. Atropin acts after destruction of the ciliary [ophthalmic] ganglion (Hensen and Völckers), and in the excised eye (De Ruyter, Rottmann).

[*Cocaine*, or *Cucaïne*, is obtained from the leaves of *Erythroxylon coca*. When applied locally it acts as a powerful local anæsthetic, and hence it is very useful for operations about the muco-cutaneous orifices. A 4 per cent. solution dropped into the eye produces complete insensibility of the cornea in a few minutes. It causes dilatation of the pupils, though they react to light, and to the movements of

accommodation. It also causes temporary paralysis of accommodation, a sensation of heaviness and coldness of the eyeball, enlargement of the palpebral fissure, constriction of the small peripheral vessels, and slight lachrymation.]

Myotics are those substances which *contract* the pupil:—*Physostigmin* (= Eserin, the alkaloid of Calabar bean), nicotin, pilocarpin, muscarin, morphin, according to some observers (Grünhagen) cause stimulation of the oculomotorius, while others (Hirschmann, Rosenthal) say they paralyse the sympathetic. As these substances cause spasm of the ciliary muscle, it is supposed that the first of these has an analogous action on the sphincter. It is *probable* that they paralyse the dilator fibres and stimulate the oculomotor fibres.

If the one pupil be contracted or dilated by these substances, the other pupil, conversely, is dilated or contracted, owing to the change in the amount of light admitted into the eye into which the poison has been introduced.

The **anæsthetics** (ether, chloroform, alcohol, etc.), when they begin to cause stupor, contract the pupil, and when their action is intense, they dilate it (Dogiel). Chloroform, during the stage when it causes excitement (preceding the narcosis), stimulates the centre for the dilatation of the pupil; after a time this centre is paralysed, so that the pupil no longer dilates on the application of external stimuli. Thereafter the pupillo-constrictor centre is stimulated, whereby the pupil may be

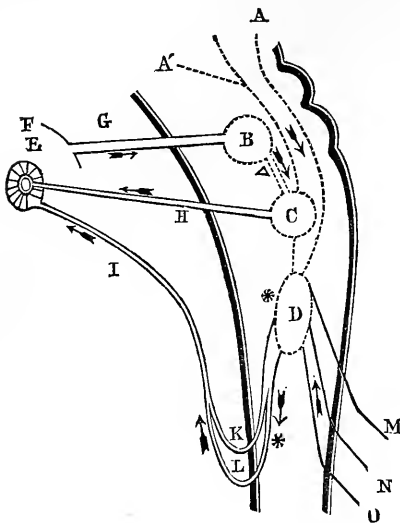

Fig. 398.

Scheme of the nerves of the iris, after Erb—
B, Centrum optici; C, oculomotor centre;
D, dilator centre (spinal); E, iris; G,
optic nerve; H, oculomotor (sphincter)
roots; I, sympathetic (dilator): K, L,
anterior roots; M, N, O, posterior roots;
Δ, seat of lesion, causing pupillary im-
mobility; *, probable seat of lesion,
causing myosis.

contracted to the size of a pin's head; ultimately this centre is paralysed, and the pupil becomes dilated.

Intraocular Pressure.—The movements of the iris are always accompanied by variations of the intraocular pressure. The muscles of the iris affect the intraocular pressure, in that the dilatation of the pupil increases it, while contraction of the pupil diminishes it. The increased or diminished tension can be felt when two fingers are pressed on the eyeball. Stimulation of the sympathetic increases, while its section diminishes the pressure. Atropin dropped into the eye, after producing a short temporary diminution of the tension, increases it; eserin, after a primary increase, causes a diminution of the pressure (Graser and Hölzke).

The reflex dilatation of the pupil occurs slightly later than the reflex contraction, the time in the two cases being 0.5 and 0.3 second respectively after stimulation by light (v. Vintschgau.) A certain *time* always elapses, until the iris, corresponding to the strength of the stimulus of light exciting the retina, "adapts" (Aubert) itself to produce a suitable size of the pupil. Contraction of

the pupil occurs very rapidly after stimulation of the oculomotorius in birds; in rabbits 0.89 second (Arlt, jun.) elapses after stimulation of the sympathetic, until the dilatation begins.

Excised Eye.—Light causes contraction of the pupil in the *excised* eye of amphibians and fishes (Arnold, Budge). Even the iris of the eel, when cut out and placed in normal saline solution, contracts to light (Arnold, Gysi and Luchsinger), the green and blue rays being most active.

Increase of the temperature causes mydriasis in the excised eye of the frog or eel, while cooling causes myosis (H. Müller, Biernath).

[Size of the Pupil.—Jonathan Hutchinson recommends a *pupilometer*, consisting of a metal-plate perforated with a series of holes of different sizes. The smallest hole measures about $\frac{1}{3}$ of a line, and the largest is $4\frac{1}{2}$ lines. The plate is placed just below the patient's eye, and the hole is selected which corresponds with the size of the pupil.]

[Gorham's Pupil Photometer.—This ingenious instrument may be used as a *pupilometer*, and also as a photometer. It consists of a piece of bronzed tubing (Fig. 399, and 400), 1.9 in. long and 1.5 in. diameter. One end is closed by a disc or cap (Fig. 399), which is pierced in its radii by a series of holes at distances varying from .05 in. to .28 in. There is a slot in the cap which allows one pair of holes to be visible at a time, while on the cylinder is engraved the linear distance of each pair of holes. In using the instrument as a *pupilometer*, look through the open end of the tube (the bottom in Fig. 340), with both eyes open, towards a sheet of white paper or the sky, when two discs of light will be seen. Then revolve the lid or cap slowly until the two white discs *just touch one another at their edges*. The decimal fraction opposite the two apertures seen on the scale outside indicates the diameter of the pupil in 100ths of an inch.]

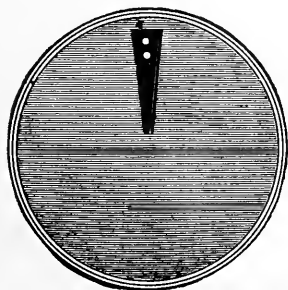

Fig. 399.

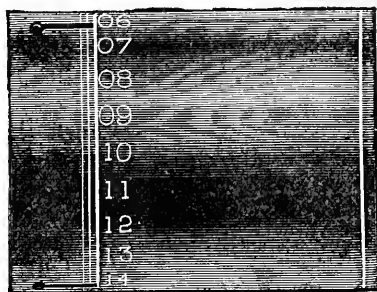

Fig. 340.

Gorham's pupil photometer—Fig. 399 shows the disc with a slot and two holes; Fig. 400 the instrument from the side, with the diameter of the pupil marked on its side. The upper end is closed by the disc, while the lower end is open.

[When using it as a *photometer*, it is assumed that the size of the pupil gives an index of the intensity of the amount of light which influences the diameter of the pupil.]

393. Entoptical Phenomena.

PERCEPTION OF PARTS LYING WITHIN THE EYE IN CONSEQUENCE OF STIMULATION OF THE RETINA.

Entoptical phenomena depend upon the perception of objects present within the eyeball itself. Amongst them are—

1. **Shadows** are formed upon the retina by different opaque bodies. In order to see them in one's own eye proceed thus:—By means of a strong convex lens project a small image of a flame upon a paper screen, prick a small opening through the image of the flame, and place one eye at the other side of the screen, so that the illuminated puncture lies in the anterior focus of the eye, *i.e.*, about 13 mm. in front of the cornea. As the rays proceeding from this point pass parallel through the media of the eye, a diffuse bright field of vision, surrounded by the black margins of the iris, is obtained. All dark bodies which lie in the course of the rays of light, throw a shadow upon the retina, and appear as specks. There are various forms of these shadows (Fig. 401).

(a) The **spectrum mucro-lacrimale**, especially upon the margin of the eyelids, depending upon particles of mucus, fat globules from the Meibomian glands, dust mixed with tears, causing cloudy or drop-like retinal shadows, which are removed by winking.

(b) **Folds in the Cornea**.—If the cornea be pressed laterally with the finger, wrinkled shadows, due to temporary wrinkles in the cornea, are produced.

(c) **Lens' Shadows**.—Bead-like or dark specks, bright and star-like figures, the former due to deposits on and in the lens, the latter to the radiate structure of the lens.

(d) The **muscæ volitantes** (Dechales, 1690), like strings of beads, circles, groups of balls or pale stripes, depend upon opaque particles (cells, disintegrating cells, granular fibres—Donders, Duncan) in the *vitreous humour*. They move about when the eye is moved rapidly. Listing (1845) showed that one may determine pretty accurately the position of these objects. Whilst making the observation upon one's own eyes, raise or depress the source of light, those shadows which are caused by bodies on a level with the pupil, retain their relative positions in the bright field of vision. Shadows, which appear to move in the same direction as the source of light, are caused by bodies, which lie in *front* of the plane of the pupil—those, however, which appear to move in the opposite direction, depend upon objects behind the plane of the pupil.

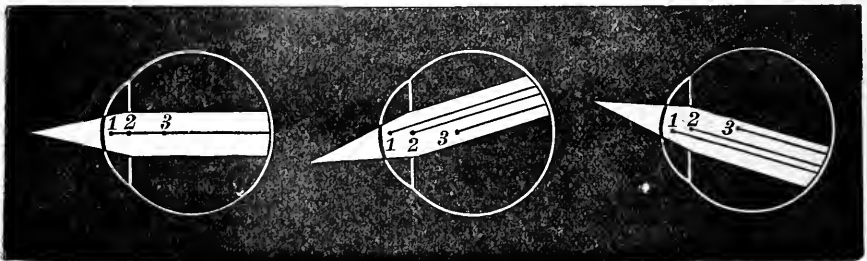

Fig. 401.

Entoptical Shadows.

2. **Purkinje's figure** (1819) depends upon the blood-vessels within the retina, which cast a shadow upon the most external layer of the retina, viz., upon the rods and cones, these being the parts acted upon by light. In ordinary vision we do not observe these shadows. According to v. Helmholtz, this is due to the fact that the sensibility of the shaded parts of the retina is greater, and their excitability is less exhausted, than all the other parts of the retina. As soon, however, as we change the position of the shadow of the blood-vessels, instead of being directly behind, so that the blood-vessels come to lie more *laterally* and behind them, *i.e.*, upon places which do not receive shadows from the blood-vessels when the rays of light pass through the eye in the ordinary way, then the figure of the blood-vessels becomes apparent at once. All that is necessary is to cause the light to enter the eyeball obliquely.

Method.—1. This may be done by passing an intense light through the sclerotic, *e.g.*, by throwing upon the sclerotic a small, bright, luminous image from a source of light. On moving the source of light, the figure of the blood-vessels moves in the same direction. 2. Look directly upwards to the sky, wink with the upper eyelid drooping, so that for a moment, corresponding to the act of winking, rays of light enter obliquely the lowest part of the pupils. 3. Look through a small aperture towards a bright sky, and move the aperture rapidly to and fro, so that from both sides of the blood-vessels shadows fall rapidly upon the nearest series of rods and cones. 4. In a darkened room, look straight ahead, and move a light to and fro close under the eyes. Occasionally, whilst performing this experiment, one may see the macula lutea, as a non-vascular, shaded depression (Purkinje, Burow), and, owing to the inversion of the objects, it lies on the *inner* side of the entrance of the optic nerve.

3. **Observing the Movements of the Blood-Corpuscles in the Retinal Capillaries** (Boisser).—On looking, without accommodating the eye, towards a large bright surface, or through a dark-blue glass towards the sun, we see bright spots, like points, forming longer or shorter chains, moving in tortuous paths. The phenomenon is, perhaps, caused by the red blood-corpuscles (in the capillaries posterior to the external granular layer—His) acting as small light-collecting concave discs, concentrating the light falling upon them from bright surfaces, and throwing it upon the rods of the retina. Each corpuscle must be in a special position; should it rotate, the phenomenon disappears. Vierordt, who projected the movement upon a screen, calculated, from the velocity of their motion, the velocity of the blood-stream in the retinal capillaries as equal to 0.5–0.75 mm. in a second, which corresponds very closely with the results obtained directly in other capillaries by E. H. Weber and Volkmann (§ 90, 4). When the carotids are compressed, the movement is slower on freeing them from the compression; during short forced expirations the movement is accelerated (Landois).

4. **The entoptical pulse** (§ 79, 2—Landois) depends upon the pulsating retinal arteries irritating mechanically the rods lying outside them.

5. **Pressure Phosphenes.**—Pressure applied to the eye causes a series of phenomena :—(a.) Partial pressure upon the eyeball causes the so-called illuminated "pressure-picture" or *phosphene*, which was known to Aristotle. As the impression upon the retina is referred to something outside the eye, the phosphene is always perceived on the side of the field of vision *opposite* to where the pressure affects the retina, *e.g.*, pressure upon the *outer* surface of the eyeball causes the flash of light to appear on the *inner* side. If the retina is not well lighted, the phosphene appears luminous; if the retina is well lighted it appears as a dark speck, within which the visual perception is momentarily abolished. (b.) If a uniform pressure be applied to the eyeball continuously from before backwards, as Purkinje pointed out, after some time very sparkling, variable figures appear in the field of vision, which perform a wonderful, fantastic play, and often resemble

the sparkling effects obtained in a kaleidoscope (v. Helmholtz), and are probably comparable to the feeling of formication produced by pressure upon sensory nerves ("sleeping of the limbs"). (c.) By applying equable and continued pressure, Steinbach and Purkinje observed a net-work with moving contents of a bluish silvery colour, which seemed to correspond to the retinal veins. Vierordt and Laiblin observed the branching of the blood-vessels of the *choroid* as a red net-work upon a black ground. (d.) According to Houdin, we may detect the position of the yellow spot by pressure upon the eyeball.

6. **The entrance of the optic nerve** may be detected on moving the eyes rapidly backwards, and especially inwards, as a fiery ring or semi-circle about the size of a pea. Probably, owing to the movement of the retina, the entrance of the optic nerve is stimulated mechanically by the rapid bending. Purkinje and others observed that the ring remained persistent on turning the eye strongly inwards. If the retina be brightly illuminated, the ring appears dark, and when the field of vision is coloured the ring has a different tint. If Purkinje's figure be produced at the same time, one may observe that the vascular trunk proceeds from this ring—a proof that the ring corresponds to the entrance of the optic nerve (Landois).

7. **Accommodation Spot.**—On accommodating the eye strongly towards a white surface, there appears in the middle a small, bright, trembling shimmer, and in its centre a coarse brown speck, about the size of a pea, is seen (Purkinje, Helmholtz). If pressure be applied externally to the eyeball, this speck becomes more distinct. After having once observed the phenomenon, occasionally we may see it on pressing laterally upon the opened eye, as a bright speck in the field of vision—another proof that the intraocular pressure is increased during accommodation (Landois).

8. **Mechanical Optical Stimulation.**—On dividing the optic nerve in man, as in extirpation of the eyeball, a flash of light is observed at the moment of section by the person operated on. The section of the nerve-fibres themselves is painless, but the sheaths are painful.

9. The **accommodation phosphene** (Purkinje, Czermak) is the occurrence of a fiery ring at the periphery of the field of vision, seen on suddenly bringing the eyes to rest, after accommodating for a long time in the dark. The sudden tension of the zonule of Zinn resulting from the relaxation, causes a mechanical stretching of the outermost part of the margin of the retina, or it may be of a part of the retina behind this (Hensen and Völckers, Berlin). Purkinje observed the phenomenon after suddenly relaxing pressure on the eye.

10. **Electrical Phenomena.**—Electrical currents, when applied to the eye, cause a strong flash of light over the whole field of vision. One pole of the battery may be placed on the upper eyelid and the other on the neck. The flash at closing [making] the current is strongest with an ascending current, that with opening [breaking] the current with a descending current (v. Helmholtz). If a uniform, continuous, *ascending* current be transmitted through the closed eyes, the dark disc of the elevation at the entrance of the optic nerve appears in a whitish, *violet* field of vision; with a *descending* current, the field of vision is *reddish* and dark, in which the position of the optic nerve appears light blue (v. Helmholtz). If external colours are looked at simultaneously, these colours blend to form a violet or yellow, with the colours looked at (Schelske). During the passage of the ascending current, we see external objects indistinctly, and *smaller* when the eyes are open; while, with the descending current, they are more distinct and *larger* (Ritter). Sometimes the position of the macula lutea appears dark on a bright ground, or the reverse, according to the direction of the current. If the current be opened [broken] the phenomena are reversed (§ 335), and the eye soon returns to rest (v. Helmholtz).

11. The **yellow spot** appears sometimes as a dark circle, when there is a

uniform blue illumination. In a strong light, the position of the yellow spot is surrounded by a bright area, twice or thrice as large, called "*Löwe's ring*."

[**Clerk-Maxwell's Experiment.**—On looking through a solution of chrome-alum in a bottle or vessel, with parallel glass sides, we observe an oval purplish spot in the green colour of the alum. This is due to the pigment of the yellow spot.]

Haidinger's Brushes.—On directing the eye towards a source of polarised light, "Haidinger's polarised brushes" appear at the point of fixation. They are seen on looking through a Nicol's prism at a bright cloud (v. Helmholtz). They are bright and bluish on a surface, bounded by two neighbouring hyperbola, on a white field; the dark bundle separating them, is smallest in the centre, and yellow. Of the various colours of homogeneous light, blue alone shows the brushes (Stokes). According to v. Helmholtz, the seat of the phenomenon is the yellow spot, and is due to the yellow-coloured elements of the yellow spot being slightly doubly refractive, while at one part they absorb more, at another less, of the rays entering the eye.

12. Lastly, there are the visual sensations depending on **internal causes**—*e.g.*, increased bounding of the blood through the retina, as during violent coughing, increased intraocular pressure. Stimulation of the *psycho-optic centres* (§ 378, IV) may produce spectra, which Cardanus (1550), Goethe, and Johannes Müller could produce voluntarily.

394. Illumination of the Eye and the Ophthalmoscope.

The light which enters the eye is partly absorbed by the black uveal pigment, and partly again reflected from the eye, and always in the same direction in which the rays entered the eye. By placing one's self in front of the eye of another person, of course the head, being an opaque body, cuts off a large number of rays. Owing to the position of the head, no rays of light can enter the eye; and, of course, none can be reflected back to the eye of the observer. Hence, the eye of the person being examined always appears black, because those rays which alone could be reflected in the direction of the eye of the observer, are cut off. As soon, however, as we succeed in causing rays of light to enter the eye at the same time and in the *same* direction in which we observe the eye of another person, the fundus of the eye appears brightly illuminated.

The following simple arrangement (Fig. 402) is sufficient for the purpose:—Let B be the eye of the patient, A that of the observer, and let a flame be placed at *x*. The rays of light proceeding from *x* impinge upon the obliquely placed *plate of glass* (S, S), and are reflected in the direction of the dotted lines into the eye (B). The fundus of the eye appears in this position to be brightly illuminated in diffusion circles around *b*. As the observer (A) can see through the obliquely placed glass plate (S, S), and in the same direction as the reflected rays (*x, y*) he sees the retina around *b* brightly illuminated.

In order that this method be made available for practical purposes we must, of course, be able to distinguish the details, such as the blood-vessels of the fundus of the eye, the macula lutea, the entrance

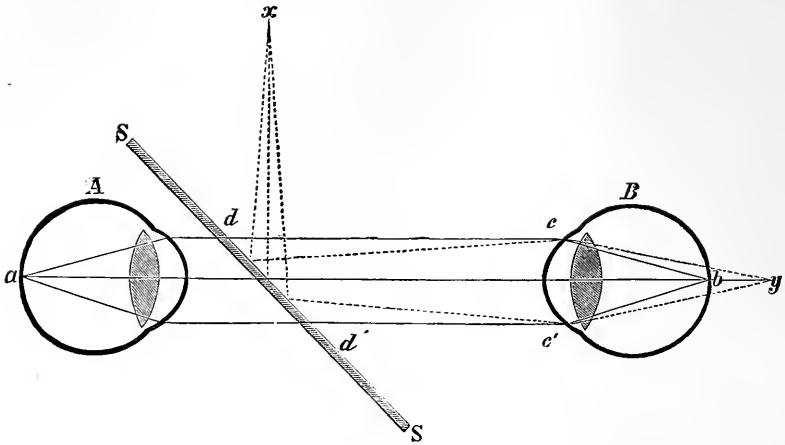

Fig. 402.

Arrangement for examining the eye of B—A, Eye of observer; x , source of light; S, S, plate of glass directed obliquely, reflecting light into B.

of the optic nerve, abnormalities of the retina, and the choroidal pigment, &c. The following considerations show us how to proceed in

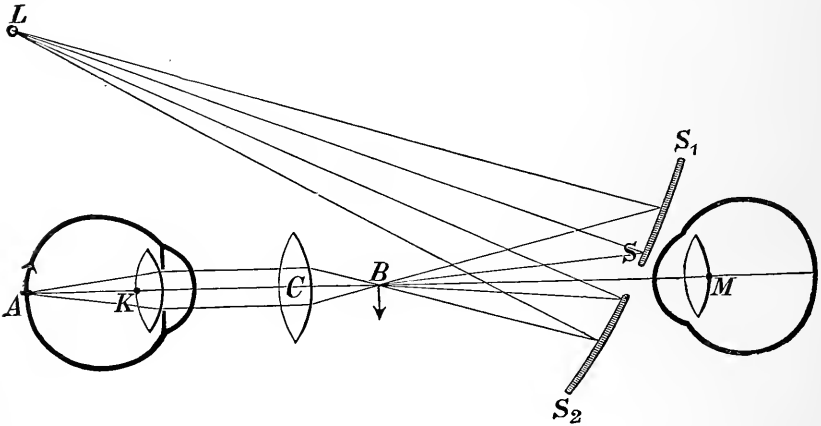

Fig. 403.

order to accomplish this. As already mentioned, and as Fig. 385, p. 973, shows, a small inverted image is formed on the retina (c, d) when we look at an object (A, B); conversely, according to the same

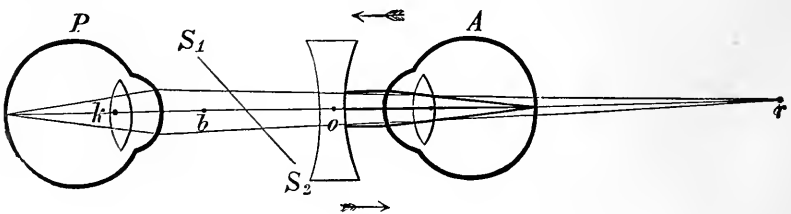

Fig. 404.

dioptric law, an enlarged inverted real image of a small distinct area of the retina (*c, d*—depending on the distance for which the eye was accommodated), must be formed outside the eye (*A, B*).

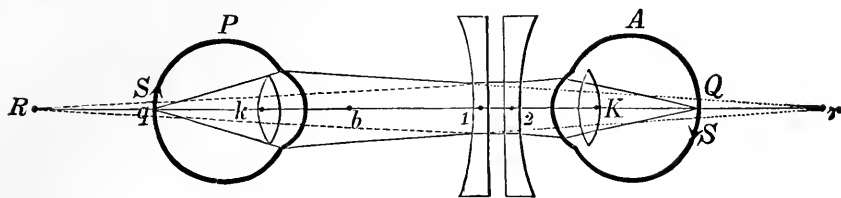

Fig. 405.

If the fundus of this eye be sufficiently illuminated, this aerial image will be correspondingly bright.

In order to see the individual parts of the retinal picture more distinctly, the observer must accommodate his own eye for the position of this image. In such circumstances the eye of the observer would be too near to the observed eye.

His eye when so accommodated is removed from the eye of the patient by his own visual distance, and by the visual distance of the patient. As this distance is considerable, the individual small details of the fundus cannot be seen distinctly. Further, owing to the contraction of the pupil of the patient, only a small area of the fundus can be seen, and this only under a

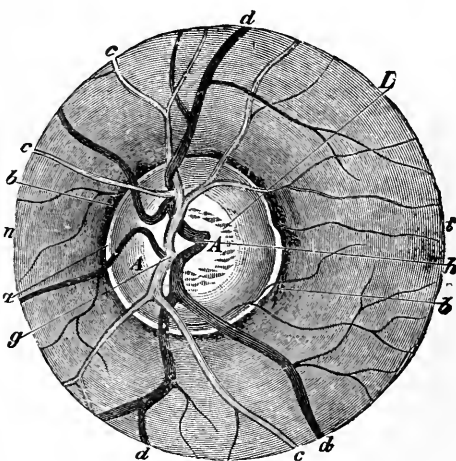

Fig. 406.

The entrance of the optic nerve with the adjacent parts of the fundus of the normal eye (after Ed. Jæger)—*a*, Ring of connective-tissue; *b*, choroidal ring; *c*, arteries; *d*, veins; *g*, division of the central artery; *h*, division of the central vein; *L*, lamina cribrosa; *t*, temporal (outer) side; *n*, nasal (inner) side:

small visual angle, quite apart from the fact that it is often impossible to accommodate for the real image of the fundus of the patient.

Hence, the eye of the observer must be brought nearer to the eye of the patient. This may be done in two ways:—1. Either by placing in front of the eye of the patient a strong *convex lens* (of 1–3 inches focus—Fig. 403, C). This causes the retinal image to be nearer to the eye (at B), owing to the strong lens refracting the rays of light. The

observer (M) can come nearer to the eye, and can still accommodate for the image of the fundus of the eye. 2. Or a *concave lens* is placed immediately in front of the eye of the patient (Fig. 404, *o*). The rays of light emerging from the eye of the patient (P) are either made parallel by the concave lens (*o*), and are brought to a focus on the retina of the emmetropic observer (A); or, if the lens causes the rays to diverge (Fig. 405), an erect, virtual image is formed at a distance behind the eye of the patient (at R). In these cases, also, the observer can go much nearer to the eye of the patient.

The **ophthalmoscope**, invented by v. Helmholtz, enables us to examine the whole of the fundus of the eye.

[Direct Method.—Use a concave mirror of 20 centimetres focal distance, with a central opening. Reflect a beam of light into the patient's eye, where they cross in the vitreous and illuminate the fundus of the eye. These rays again pass out of the eye and reach the observer's eye through the central hole in the mirror. If the observer be emmetropic they come to a focus on his retina. In this way all the parts of the retina are seen in their normal position, but enlarged. Hence, it is sometimes called the examination of the *upright image*. The eye of the patient and observer must be at rest, *i.e.*, be negatively accommodated, while the mirror must be brought as near as possible to the eye of the patient.]

[Indirect Method, by which a more general view of the fundus is obtained. Throw the light into the patient's eye by an ophthalmoscopic mirror as above, but held at distance of about 50 cm. (10 inches) from the patient's eye. Hold a biconvex lens of 14 dioptrics focal length vertically between the mirror and the patient's eye (Fig. 403), the observer looking through the hole of the mirror. What he does see is an *inverted aerial image* at B. Only a small part of the fundus oculi can be seen at one time.]

[The ophthalmoscope, besides being used for examining the interior of the eyeball, is of the utmost use in determining the existence and amount of anomalies of refraction in the refractive media. For this purpose an ophthalmoscope requires to be provided with plus and minus lenses, which can be readily brought before the eye of the observer. This is readily done by an ingenious mechanism devised by Couper, and which is made use of in the handy students' ophthalmoscope of Morton (Fig. 407). The lenses are moved by a driving-wheel on the left figure, while at the same time is indicated at a certain aperture the lens presented at the sight hole. The instrument is also provided with a movable arrangement carrying a concave mirror at either end. One of these mirrors is 10 in. in focus, and is used for indirect examination and retinoscopy, while the other is of 3 in. focus, for direct examination, and is fixed at an angle of 25°.]

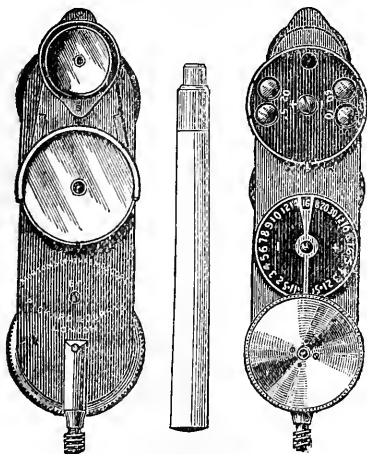

Fig. 407.

Morton's ophthalmoscope
(Pickard & Curry).

[Retinoscopy.—The ophthalmoscope is used also for this purpose. A beam of light is reflected into the eye by the ophthalmoscopic mirror, and the

play of light and shade on the fundus oculi observed. A study of this is important in determining anomalies of refraction. For the method, the student is referred to a text-book on "Diseases of the Eye.]"

[**Artificial Eye.**—The student may practise the use of the ophthalmoscope on an artificial eye such as that of Frost (Fig. 408) or Perrin.]



Fig. 408.

Frost's artificial eye.

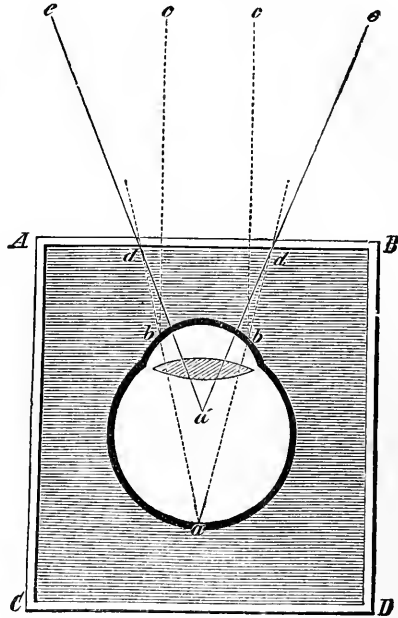

Fig. 409.

Action of the Orthoscope.

Illumination.—In order to illuminate the interior of the eye, v. Helmholtz used several plates of glass, placed behind each other, in the position of S, S, in Fig. 402. Afterwards he used a plane or concave mirror of 7 inches focus (Fig. 403, S₁, S₂), with a hole in its centre. Fig. 406 shows the appearance of the fundus of the eye, as seen with the ophthalmoscope.

In albinos the fundus of the eye appears red, because light passes into the eye through the sclerotic and uvea, which are devoid of pigment. If a diaphragm be placed over the eye, so that the pupil alone is free, the eye appears black (Donders).

Tapetum.—In many animals the eyes have a bright green lustre. These eyes have a special layer, the tapetum, or the membrana versicolor of Fielding; in carnivora it consists of cells, in herbivora of fibres, placed between the capillaries of the choroid and the stroma of the uvea. These structures exhibit interference colours and reflect much light, so that a coloured lustre appears in the eye.

Oblique illumination is used with advantage for investigating the anterior chamber. A bright beam of light, condensed by a convex lens, is thrown *laterally* upon the cornea into the eye, and so directed upon the point to be investigated as to illuminate it. A point so illuminated, *e.g.*, a part of the iris, may be examined from a distance by means of a lens, or even by a microscope (Liebreich).

The **Orthoscope**.—Czermak constructed this instrument (Fig. 409), in which the eye is placed under water. Take a small glass trough with one of its walls removed. Press the margins of the open side firmly against the region of the eye. The eye and its surroundings form, as it were, the sixth side of the trough, which is filled with water, so that the cornea is bathed therewith. As the refractive index of water is almost the same as the refractive index of the media of the eye, the rays of light pass into the eye in a straight direction without being refracted. Hence, objects in the anterior chamber can be seen directly, as if they were not within the eye at all. Another advantage is, that the objects can be brought nearer to the eye of the observer. The rays of light emerging from the point (*a*) of the fundus, if the eye were surrounded by air, would leave the eye as the parallel lines, *b, c, b, c*. Under water, these rays, *a, b*, continue in the direction *a, b*, as far as *b, d*, where they emerge from the water, and are bent from the perpendicular, to *d, e, d, e*. The eye of the observer, looking in the direction *e, d*, sees the point, *a, nearer, viz., in the direction, e d, a', lying at a*.

395. Activity of the Retina in Vision.

I. **Blind Spot**.—The rods and cones alone are the parts of the retina sensitive to light (Heinr. Müller), they alone are excited by the vibrations of the ether. This is confirmed by Mariotte's experiment (1688), which proves that the entrance of the optic nerve, where rods and cones are absent, is devoid of visual sensibility. Hence it is spoken of as the "*blind spot*."



Fig. 410.

[**Mariotte's Experiment**.—Make two marks, about three inches apart, upon paper (Fig. 410). Look at the cross with the right eye, keeping the left eye closed, and hold the paper about a foot from the eye, when both the cross and the circle will be seen. Gradually approximate the paper to the eye, keeping the open eye steadily fixed on the cross; at a certain moment the circle will disappear, and on bringing the paper nearer to the eye it will reappear. The moment when the circle disappears is when its image falls upon the entrance of the optic nerve.]

Position and Size.—The entrance of the optic nerve lies about 3.5 mm. internal to the visual axis of the eyeball, in the retina. Its diameter is 1.8 mm. (Helmholtz). The apparent diameter of the blind spot in the field of vision is in a horizontal direction 6°56'—this lies 12°35' to 18°55' horizontally from the fixed point. Eleven full moons placed side by side, would disappear on this surface, and so would a human face at a distance of over two metres.

Proofs.—The following facts prove that the entrance of the optic nerve is

insensitive to light :—1. Donders projected, by means of a mirror, a small image of a flame upon the entrance of the optic nerve of another person, and the person had no sensation of light. But a sensation of light was experienced when the image of the flame was projected upon the neighbouring parts of the retina. 2. On combining with Mariotte's experiment, the experiment which causes entoptical phenomena at the entrance of the optic nerve (§ 393, 6 and 7), this coincides with the blind spot (Landois).

Form of Blind Spot.—In order to determine the *form and apparent size of the blind spot* in one's own eye, fix the head at about 25 centimetres from a surface of white paper; select a small point on the latter and keep the eye directed towards it, then starting from the position of the blind spot move a white feather in all directions over the paper; whenever the tip of the feather becomes visible, make a mark at this spot. Thus the blind spot may be mapped out. It is found to have an irregular elliptical form, from which processes proceed, due to the equally non-sensitive origins of the large blood-vessels of the retina (Hueck, Helmholtz). (Mariotte concluded from his experiment that the choroid, which is perforated by the optic nerve, is the membrane sensitive to light, as the nerves are nowhere absent from the retina.)

The blind spot does not cause any appreciable gap in the field of vision.—As this area is not excited by light, a black spot cannot appear in the field of vision, for the sensation of black implies the presence of retinal elements, which, however, are absent from the blind spot. The circumstance, however, that in spite of the existence of an inexcitable spot, during vision, no part of the field of vision appears to be *unoccupied*, is due to a psychical action. The unoccupied area of the field of vision, corresponding to the blind spot, is filled in, according to probability, by a psychical process (E. H. Weber). Hence, when a white point disappears from a black surface, the whole surface appears to us black; a white surface, from which a black point falls on the blind spot, appears quite white; a page of print, grey throughout, &c. According to the probabilities, certain parts are supplied—parts of a circle, the middle parts of a long line, the central part of a cross. Such images, however, which cannot be constructed according to the probabilities, are not perfected, *e.g.*, the end of a line or a human face. In other cases the condition known as "*contraction*" of the field of vision tends to fill up the gap. This will be evident on looking at the nine adjoining letters, so that *e* disappears, we no longer see the three letters on each side of it in straight lines, but *b*, *f*, *h*, *d*, are turned in towards *e*. The adjoining parts of the field of vision seem to extend over and around the blind spot, and thus help to compensate for the blind spot.

a b c
d (e) f
g h i

II. Optic Fibres Inexcitable to Light.—The layer of the *fibres of the optic nerve* in the retina is *not sensitive to light*. This is proved by the fact that in the fovea centralis, which is the area of most acute vision, there are no nerve-fibres. Further, Purkinje's figure proves that, as the arteries of the retina lie behind the optic fibres, the latter cannot be concerned in the perception of the former.

III. Rods and Cones.—The outer segments of the rods and cones have rounded outlines, and are packed close together, but natural spaces must exist between them, corresponding to the spaces that must exist between groups of bodies with a circular outline. These parts are insensible to light, so that a retinal image is composed like a mosaic of round stones. The diameter of a cone in the yellow spot is $2\cdot2\cdot5 \mu$

(M. Schultze). If two images of two small points, placed very near each other, fall upon the retina, they will still be distinguished as distinct images, provided that both images fall upon two different cones. The two images on the retina need only be 3-4-5.4 μ apart,

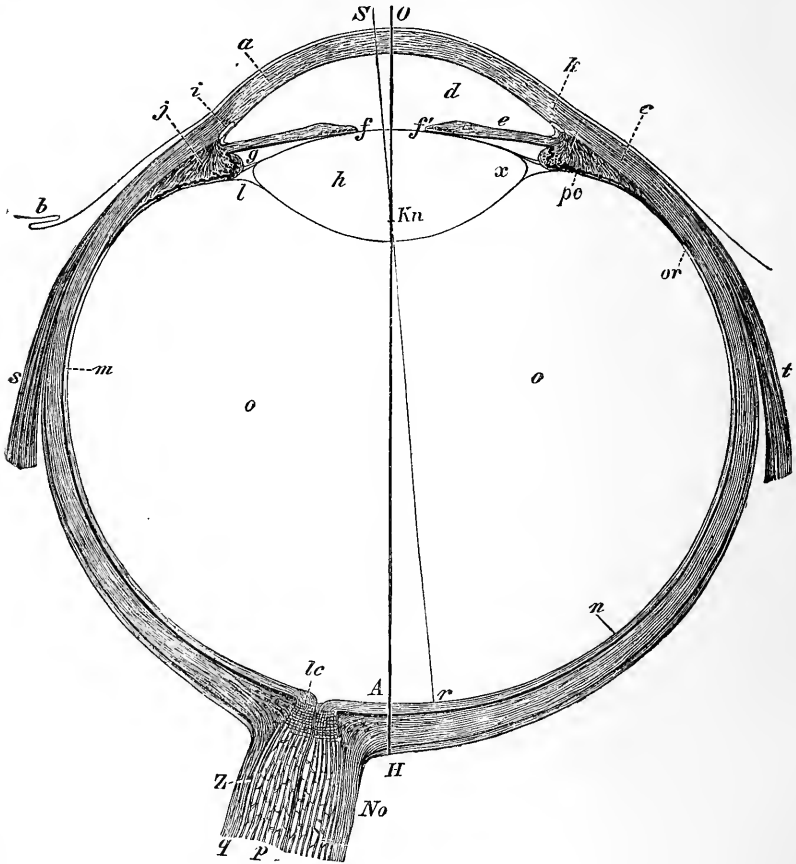

Fig. 411.

Horizontal section of the right eye.

a, Cornea; *b*, conjunctiva; *c*, sclerotic; *d*, anterior chamber containing the aqueous humour; *e*, iris; *ff'*, pupil; *g*, posterior chamber; *l*, Petit's canal; *j*, ciliary muscle; *k*, corneo-scleral limit; *i*, canal of Schlemm; *m*, choroid; *n*, retina; *o*, vitreous humour; *No*, optic nerve; *q*, nerve-sheaths; *p*, nerve-fibres; *lc*, lamina cribrosa. The line, *O A*, indicates the optic axis; *S r*, the axis of vision; *r*, the position of the fovea centralis.

in order that each may be seen separately, for then the images still fall upon *two* adjoining cones. If the distance be diminished so very much that both images fall upon *one* cone, or one upon one cone and the other

upon the intermediate [cement] substance, then only *one* image is perceived. The images must be further apart in the peripheral portion of the retina in order that they may be separately distinguished.

As the rounded end-surfaces of the cones do not lie exactly under each other, but are so arranged that one series of circles is adapted to the interstices of the following series, this explains why fine dark lines, lying near each other, appear to have alternating twists upon them, as the images of these must fall upon the cones, at one time to the right, at another to the left.

IV. The fovea centralis is the region of most acute vision, where only cones are present, and where they are very numerous and closely packed. The cones are less numerous in the peripheral areas of the retina, and consequently vision is much less acute in these regions. We may therefore conclude that the cones are more important for vision than the rods. When we wish to see an object distinctly we involuntarily turn our eyes, so that the retinal image falls upon the fovea centralis. In doing this we are said to "*fix*" our eyes upon an object. The line drawn from the fovea to the object is called the axis of vision (Fig. 411, *Sr*). It forms an angle of only $3\cdot5-7^\circ$ with the "*optical axis*" (*OA*), which unites the centres of the spherical surfaces of the refractive media of the eye. The point of intersection, of course, lies in the nodal point (*Kn*) of the lens (p. 1004). The term "*direct vision*" is applied to vision when the direction of the axis of vision is in line with the object, [*i.e.*, when the image of the object falls directly on the fovea centralis].

"*Indirect vision*" occurs when the rays of light from an object fall upon the *peripheral* parts of the retina. Indirect vision is much less acute than the direct.

In order to test the acuteness of *direct vision*, draw two fine parallel lines close to each other, and gradually remove them more and more from the eye, until both appear *almost* to unite and form one line. The size of the retinal image may be ascertained by determining the distance of the two lines from each other, and the distance of the lines from the eye; or, from the corresponding visual angle, which is generally between 60 to 90 seconds.

Perimetry.—In order to test *indirect vision* we may use the *perimeter* of Aubert and Fürster. The eye is placed opposite a fixed point, from which a semicircle proceeds, so that the eye lies in the centre of it. As the semicircle rotates round the fixed point, on rotating the former, we can circumscribe the surface of a hemisphere, in the centre of which the eye is placed. Proceeding from the fixed point, objects are placed upon semicircles, and are gradually pushed more and more towards the periphery of the field of vision, until the object becomes indistinct, and finally disappears. The process of testing is continued by placing the arc successively in the different meridians of the field of vision.

[M'Hardy's *perimeter* is a very convenient form (Fig. 412). It consists of two uprights (C and D), which are fixed to the opposite ends of a flat basal plate (A). C carries an arrangement for supporting the patient's head, while D carries the automatic arrangement for the perimetric record. Both of these can be raised or depressed by the screws (G and *b*). The patient's chin rests on the chin-rest (E),

while in the mouth is placed Landolt's biting fixation (L), which is detachable. The position of the head can be altered by sliding F on L, which can be fixed in any position by the screw (O). The porcelain button (I) just below the patient's eye (l) is connected with the adjustment of the "fixation point." The automatic recording apparatus consists of a revolving quadrant (*h*, *h*), which describes a hemisphere round a horizontal axis passing through the centre of the hollow male axle, turning in the female end of *a*, which is supported by D. The quadrant can be fixed at any point by *g*. On the front concave surface of the quadrant is fixed a circular white piece of ivory, which represents the "fixation point," from which a needle projects, and which is the zero of the instrument. A carriage (*i*) in which the test objects are placed can be moved in the concave face of the quadrant by means of the milled head (*j*), which moves the carriage by means of a tooth and pinion wheel.]

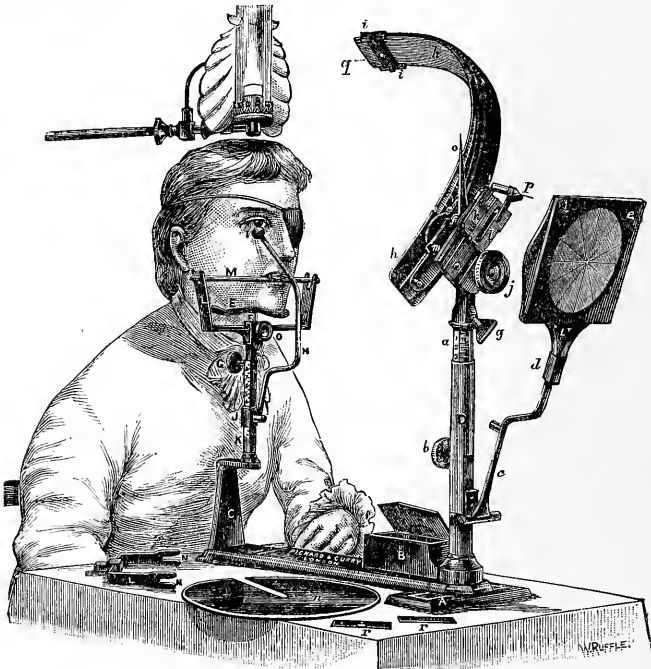

Fig. 412.

M'Hardy's perimeter—*i*, Porcelain button; M, bit; E, for fixing the head; *g*, *h*, quadrant; *o*, fixation point; *p*, pointer for piercing the record chart held in the frame (*e*) which moves on *c*; D, upright supporting the quadrant and the automatic arrangement of slides (*k* and *l*), which are moved by *j* (Pickard and Curry).

[When the milled head (*j*) is turned, it moves the carriage and two slides (*k* and *l*), the two slides moving in the ratio of 2 to 1. The rate of the carriage is so adjusted that it travels ten times faster than *l*, and five times faster than *k*. The pointer (*p*) is connected with these slides, so that it moves when they move, and records its movements by piercing the record chart, which is fixed in the double-faced frame (*e*). The frame for the record chart is hinged near *c* to the upright (D). The frame when upright comes so near the pointer that the latter can pierce

a chart placed in the frame. The patient is directed to look at the "fixation point," which is merely a small ivory button placed in the imaginary axis of the hemisphere on the front of the centre of the concave surface of the quadrant; the projecting needle point (*o*) indicates its position. This is the zero of the quadrant, and on each side of it the quadrant is divided into 90°.]

[In testing the field of vision, place the carriage so as to cover zero, adjust the eye for the fixation point, and look steadily at it, and if all is right the pointer (*p*) ought to pierce the centre of the chart. Move the carriage along the quadrant by *j* until it disappears from the field of vision, and when it does so the pointer is made to pierce the chart. Make another observation in another direction, by altering the position of the quadrant, and go on doing so until a complete record is obtained of the field of vision. Test the other eye in the same way. The colour-field may be tested by using coloured papers in the carriage.]

[Priestley Smith's perimeter (Fig. 413) is simpler. The wooden knob on the left of the figure is placed under the eye of the patient, who stares at the fixed point in the axis of the quadrant which can be moved in any meridian. The test object is a square piece of white paper which is moved along the quadrant. The chart is placed on the posterior surface of the hand-wheel and moves with it, so that the meridians of the chart move with the quadrant. There is a scale behind the hand-wheel corresponding with the circles on the chart, so that the observer can prick off his observations directly.]

[Scotoma is the term applied to dimness or blindness in certain parts of the field of vision, which may be central, marginal, or in patches.]

The capacity for distinguishing colours diminishes more rapidly at the periphery of the retina than that for distinguishing differences in the brightness or intensity of light. In fact, the periphery of the retina is slightly red blind. The diminution is greater in the vertical meridian of the eye than in the horizontal, and it diminishes with the distance from the fixation point (Aubert and Förster). These observers also state that, during accommodation for a distant object, the diminution of the capacity to distinguish brightness and colour towards the periphery of the lens, occurs more rapidly than with near vision.

The excitability of the retina for colours and brightness is greater at a point equally distant from the fovea centralis on the temporal than on the nasal side of the eye (Schön).

Perimetric Chart.—If the arc of the perimeter (Fig. 413) be divided in 90 degrees, beginning at the fixation point (central point), and proceeding to L and M (Fig. 414); and if a series of concentric circles be inscribed on this, with the point of fixation as their centre, we can construct a *topographical chart* of the visual capacity of the normal or healthy eye from the data obtained by the examination of the retina.

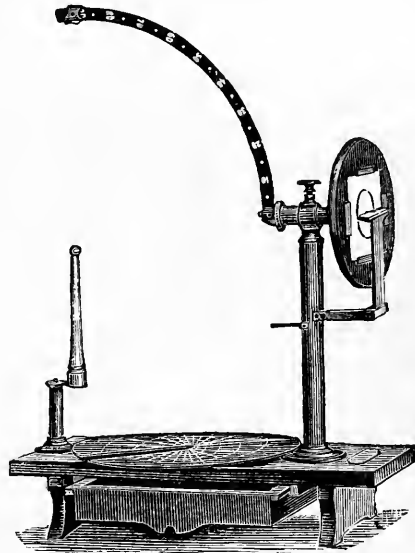

Fig. 413.

Priestley Smith's Perimeter
(Pickard & Curry.)

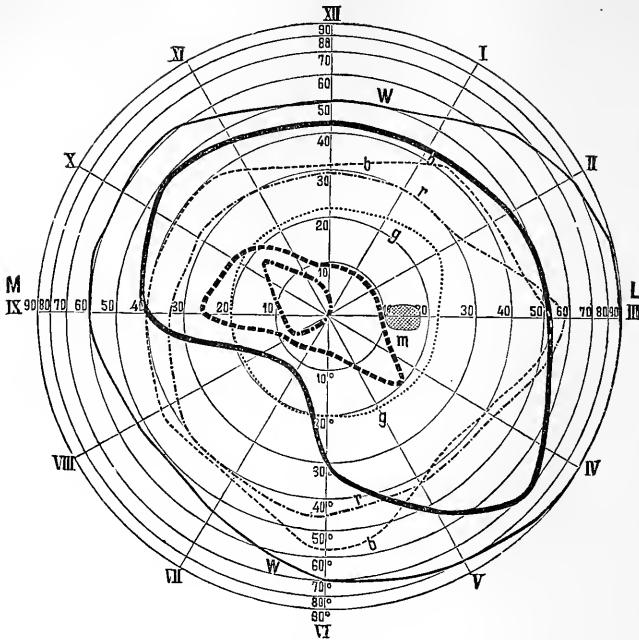

Fig. 414.

Perimetric chart of a healthy and a diseased eye.

Fig. 414 is an example; the *thick* lines indicate a diseased eye, the corresponding *thin* lines a healthy eye. The continuous line indicates the limits for the perception of white; the interrupted line that for blue, the punctuated and interrupted line that for red; *m* is the blind spot (Hirschberg). In the normal eye the limits for the perception of

	White,	Blue,	Red,	Green.
Externally,	70°-88°	65°	60°	40°
Internally,	50°-60°	60°	50°	40°
Upwards,	45°-55°	45°	40°	30°-35°
Downwards,	65°-70°	60°	50°	35°

V. Specific Energy.—The rods and cones alone are endowed with what Johannes Müller called "*specific energy*," *i.e.*, they alone are set into activity by the ethereal vibrations, to produce those impulses which result in vision. *Mechanical* and *electrical* stimuli, however, when applied to any part of the course of the nervous apparatus, produce visual phenomena. Mechanical stimuli are more intense stimuli than light rays, as shown by performing the dark pressure figure with the eyes opened (p. 995, 5, *a*), whereby the circulation in the retina is interfered with (Donders); in the region of pressure we

cannot see external objects which affect the retina uniformly and continuously.

VI. The duration of the retinal stimulation must be exceedingly short, as the electrical spark lasts only 0·00000868 second; still, as a general rule, a shorter time is required, the larger and brighter the object looked at. Alternate stimulation with light, 17–18 times per minute, is perceived most intensely (Brücke). Further, an increase or diminution of 0·01 part of the intensity of the light is perceptible (p. 954). A shorter time is required to perceive yellow than is required for violet and red (Vierordt). The retina becomes more sensitive to light after a person has been kept in the dark for a long time, and also after repose during the night. If light be allowed to act on the eyes for a long time, and especially if it be intense, it causes *fatigue* of the retina, which begins sooner in the centre than in the periphery of the organ (Aubert). At first the fatigue comes on rapidly and afterwards develops more slowly—it is most marked in the morning (A. Fick and C. F. Müller). The periphery of the retina is specially characterised by its capacity for distinguishing movements (Exner).

VII. **Visual Purple.**—The mode of the action of light upon the end-organs of the retina has already been referred to (p. 962) in connection with the "*visual purple*" [or *Rhodopsin*] (Boll, Kühne). Kühne showed that, by illuminating the retina, actual pictures (*e.g.*, the image of a window) could be produced on the retina, but they gradually disappeared. From this point of view, we might regard the retina as comparable, to a certain extent, to the sensitive plate of a photographic apparatus.

Optogram.—The visual purple is formed by the pigment-epithelium of the retina. Perhaps we might compare the process to a kind of secretion. The visual purple may be restored in a retina by laying the latter upon living choroidal epithelium. The pigment disappears from the mammalian retina by the action of light 60 times more rapidly than from the retina of the frog. In a rabbit's eye, whose pupil was dilated with atropin, Ewald and Kühne obtained a sharp picture or optogram of a bright object placed at a distance of 24 cm. from the eye—the image was "fixed" by a 4 per cent. solution of alum. Visual purple withstands all the oxidising reagents; zinc chloride, acetic acid, and corrosive sublimate change it into a yellow substance—it becomes *white* only through the action of light; the dark heat-rays are without effect, while it is decomposed above a temperature of 52°C. [As visual purple is absent from the cones, and cones only are present in the fovea centralis, we cannot explain vision by optograms formed by the visual purple.]

VIII. **Destruction** of the rods or cones of the retina causes corresponding dark spots in the field of vision.

396. Perception of Colours.

Physical.—The vibrations of the light-ether are perceived by the retina only within distinct limits. If a beam of white light, *e.g.*, from the sun, be

transmitted through a prism, the light rays are refracted and dispersed, and a "*prismatic spectrum*" (Fig. 11) is obtained. White light contains rays of very different wave lengths, or periods of vibration. The *dark heat rays*, whose wave length is 0.00194 mm. (Fizeau) are refracted least. They do not act upon the retina, and are therefore invisible. They act, however, upon sensory nerves. About 90 per cent. of these rays is absorbed by the media of the eye (Brücke and Knoblauch, Cima, Jansen). From Fraunhofer's line, A, onwards (p. 29), the oscillations of the light-ether excite the retina in the following order: *Red* with 481 billions of vibrations per second, *orange* with 532, *yellow* with 563, *green* with 607, *blue* with 653, *indigo* with 676, and *violet* with 764 billion vibrations per second. The sensation of **colour** therefore depends on the number of vibrations of the light-ether, just as the pitch of a note depends on the number of vibrations of the sounding body (Newton, 1704, Hartley, 1772). Beyond the violet lie the *chemically active* [actinic] rays of the spectrum. After cutting out all the spectrum, including the violet rays, v. Helmholtz succeeded in seeing the ultra-violet rays, which had a feeble greyish-blue colour. The heat rays in the coloured part of the spectrum are transmitted by the media of the eye in the same way as through water (Franz). The existence of the ultra-violet rays is best ascertained by the phenomenon of **fluorescence**. Von Helmholtz, on illuminating a solution of sulphate of quinine with the ultra-violet rays, saw a bluish-white light proceeding from all parts of the solution which were acted on by the ultra-violet rays. As the media of the eye themselves exhibit fluorescence (v. Helmholtz, Setschenow), they must increase the power of the retina to distinguish these rays. The ultra-violet rays are not largely absorbed by the media of the eye (Brücke, Donders).

In order that a colour be perceived, it is essential that a certain quantity of light must fall upon the retina. Blue, when at the lowest degree of brightness, gives a colour sensation with a quantity of light, which is sixteen times less than that required for red (Dobrowsky).

Intensity of the Impression of Light.—While light of different periods of vibration applied to the eye excites the different sensations of colour, the *amplitude of the vibrations* (height of the waves) determines the *intensity of the impression of light*; just as the loudness of a note depends on the amplitude of the vibrations of the sounding body. The sun's light contains all the rays which excite the sensation of colour in us, and when all these rays fall simultaneously upon the retina, we experience the sensation of white. If the colours of the spectrum obtained by means of a prism be reunited, white light is again obtained. If no vibrations of the light-ether reach the retina, every sensation of light and colour is absent, but we can scarcely apply the term *black* to this condition. It is rather the *absence of sensation*, such as, for example, is the case when a beam of light falls on the skin of the back. This does not give the sensation of black, but rather that of no sensation of light.

Simple and Mixed Colours.—We distinguish *simple* colours, e.g., those of the spectrum. In order to perceive these, the retina must be excited (set into vibration) by a distinct number of oscillations (see above). Further, we distinguish "*mixed colours*," whose sensation is produced when the retina is excited by two or more simple colours, simultaneously or rapidly alternating. The most complex mixed colour is *white*, which is composed of a mixture of *all* the simple colours of the spectrum.

The "**complementary colours**" are important. Any two colours which together give the sensation of white are complementary to each

other. The "contrast colours" are mentioned here merely to complete the list. They are closely related to the complementary colours. Any two colours which, when mixed, supplement the generally prevailing tone of the light, are contrast colours. When the sky is blue, the two contrast colours must be bluish-white; with bright gas-light, they must be yellowish-white, and in pure white light, of course, all the complementary are the same as the contrast colours (Brücke).

Methods of Mixing Colours.—1. Two solar spectra are projected upon a screen, and the spectra are so arranged as to cause any one part of one spectrum to cover any part of the other. 2. Look obliquely through a vertically arranged glass plate at a colour placed behind it. Another colour is placed in front of the glass plate, so that its image is also reflected into the eye of the observer; thus, the light of one colour transmitted through the glass plate and the reflected light from the other colour reach the eye simultaneously.

[**Lambert's Method.**—This is easily done by Lambert's method. Use coloured wafers and a slip of glass; place a red wafer on a sheet of white paper, and about three inches behind it, another blue one. Hold the plate of glass midway and vertically between them, and so incline the glass that, while looking through it at the red wafer, a reflected image of the blue one will be projected into the eye in the same direction as that of the red image, when we have the sensation of purple.]

3. A rotatory disc, with sectors of various colours, is rapidly rotated in front of the eyes. On rapidly rotating the coloured disc, the impressions produced by the individual colours are united to produce a mixed colour. If the rotating disc, which yields, let us suppose, white, on mixing the colours of the spectrum, be reflected in a rapidly rotating mirror, then the individual components of the white reappear (Landois).

4. Place in front of each of the small holes in the cardboard used for Scheiner's experiment (p. 981, Fig. 391), two differently coloured pieces of glass; the coloured rays of light passing through the holes unite on the retina, and produce a mixed colour (Czermak).

Complementary Colours.—Investigation shows that the following colours of the spectrum are complementary, *i.e.*, every pair gives rise to white:—

Red and greenish-blue; Orange and cyan-blue;
 Yellow and indigo-blue; Greenish-yellow and violet;

while green has the compound complementary colour purple (*v.* Helmholtz).

The mixed colours may be determined from the following table. At the top of the vertical and horizontal columns are placed the simple colours; the mixed colours occur where they intersect the corresponding vertical and horizontal columns:—

	Violet.	Indigo.	Cyan-blue.	Bluish-green.	Green.	Greenish-yellow.	Yellow.
Red	Purple	Dk.-rose	Wh.-rose	White	Wh.-yellow	Gold-yellow	Orange
Orange	Dk.-rose	Wh.-rose	White	Wh.-yellow	Yellow	Yellow	...
Yellow	Wh.-rose	White	Wh.-green	Wh.-yellow	Gr.-yellow
Greenish-yellow	White	Wh.-green	Wh.-green	Green
Green	White-blue	Water-blue	Bluish-green
Bluish-green	Water-blue	Water-blue
Cyan-blue	Indigo

Dk. = dark; wh. = whitish.

The following results have been obtained from observations on the mixture of colours:—

1. If two simple, but non-complementary, spectral colours be mixed with each other, they give rise to a colour sensation, which may be represented by a colour lying in the spectrum between both, and mixed with a certain quantity of white. Hence, we may produce every impression of mixed colours, by a colour of the spectrum + white (Grassman).

2. The less white the colours contain the more “saturated” they are said to be, the more white they contain they appear more unsaturated. The saturation of a colour diminishes with the intensity of the illumination.

Geometrical Colour Table.—Since the time of Newton attempts have been made to construct a so-called “geometrical colour table,” which will enable any mixed colour to be readily found. Fig. 415 shows such a colour table; white is placed in the middle, and from it to every point in the curve, which is marked with the names of the colours, suppose each colour to be so placed that, proceeding from white, the colours are arranged, beginning with the brightest tone, then always follows the most saturated tone, until the pure saturated spectral colour lies in the

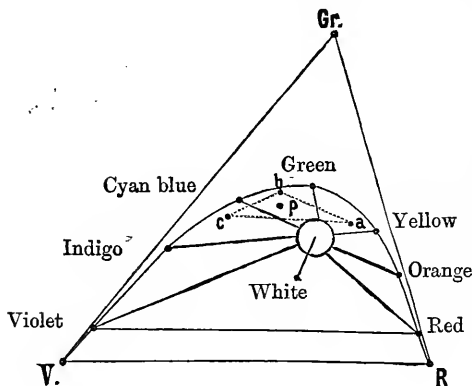

Fig. 415.

Geometrical colour cone.

point of the curve marked with the name of the colour. The mixed colour purple is placed between violet and red. In order to determine from this table the mixed colour of any two spectral colours, unite the points of these colours by a straight line. Suppose weights corresponding to the units of intensity of these colours be placed on both points of the curve indicating colours, then the position of the centre of gravity of both in the line connecting the colours, indicates the position of the mixed colour on the table.

The mixed colour of two spectral colours always lies on the colour table in the straight line connecting the two colour points. Further, the impression of the mixed colour corresponds to an intermediate spectral colour mixed with white. The complementary colour of any spectral colour is found at once by making a line from the point of this colour through white, until it intersects the opposite margin of the colour table; the point of intersection indicates the complementary colour. If pure white be produced by mixing two complementary colours, the colour lying nearest white on the connecting line must be specially strong, as then only would the centre of gravity of the lines uniting both colours lie in the point marked white.

By means of the colour table we may ascertain the *mixed colour of three or more colours*. For example, it is required to find the mixed colour resulting from the union of the point, *a* (pale yellow), *b* (fairly saturated bluish-green), and *c* (fairly

saturated blue). On the three points place weights corresponding to their intensities, and ascertain the centre of gravity of the weight, a, b, c ; it will lie at p . It is obvious, however, that the impression of this mixed colour, whitish green-blue, can be produced by green-blue + white, so that p may be also the centre of gravity of two weights, which lie in the line connecting white and green-blue.

We may describe a triangle, V, Gr, R, about the colour table so as to enclose it completely. The three *fundamental* or *primary* colours lie in the angles of this triangle, red, green, violet. It is evident that each of the coloured impressions, *i.e.*, any point of the colour table may be determined by placing weights corresponding to the intensity of the *primary colours* at the angles of the triangle, so that the point of the colour table, or, what is the same thing, the desired mixed colour, is the centre of gravity of the triangle with its angles weighted as above. The intensity of the three primary colours, in order to produce the mixed colour, must be represented in the same proportion as the weights.

Theories.—Various theories have been proposed to account for colour sensation.

1. According to one theory, colour sensation is produced by *one* kind of element present in the retina, being excited in *different ways* by light of different colours (oscillations of the light-ether of different wave lengths, number of vibrations, and refractive indices).

2. **Young-Helmholtz Theory.**—The theory of Thomas Young (1807) and v. Helmholtz (1852) assumes that *three different* kinds of nerve elements, corresponding to the three primary colours, are present in the retina. Stimulation of the first kind causes the sensation of *red*, of the second *green*, and of the third *violet*.

The elements sensitive to red are most strongly excited by light with the longest wave length, the red rays; those for green by medium wave lengths, green rays; those for violet by the rays of shortest wave length, violet rays. Further, it is assumed, in order to explain a number of phenomena, that *every colour of the spectrum excites all the kinds of fibres, some of them feebly, others strongly*. Suppose, in Fig. 416, the colours of the spectrum are arranged in their natural order from red to violet horizontally, then the three curves raised upon the abscissa might indicate the strength of the stimulation of the three kinds of retinal elements. The continuous curve corresponds to the rays producing the sensation of red, the dotted line that of green, and the broken line that of violet. Pure *red* light, as indicated by the height of the ordinates in R, strongly excites the elements sensitive to red, and feebly the other two kinds of terminations, resulting in the sensation of *red*. Simple yellow excites moderately the elements for red and green, and feebly those

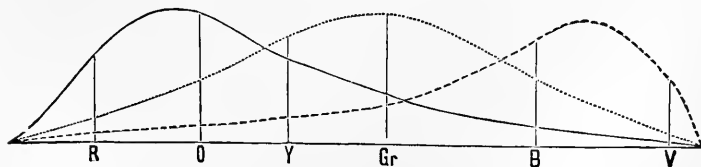

Fig. 416.

for violet=sensation of *yellow*. Simple green excites strongly the elements for green, but much more feebly the two other kinds=sensation of *green*.³ Simple blue excites to a moderate extent the elements for green and violet; more feebly

those for red=sensation of *blue*. Simple violet excites strongly the corresponding elements, feebly the others=sensation of *violet*. Stimulation of any two elements excites the impression of a mixed colour; while, if all of them be excited in a nearly equal degree, the sensation of white is produced. As a matter of fact, the Young-Helmholtz theory gives a clear and simple explanation of the phenomena of the physiological doctrine of colour. It has been attempted to make the results obtained by examination of the structure of the retina to accord with this view. According to Max Schultze, the *cones* alone are end-organs connected with the perception of colour. The presence of longitudinal striation in their outer segments is regarded as constituting them multiple terminal end-organs. Our power of colour sensation, so far as it depends on the retina, would, on this view of the matter, bear a relation to the number of cones. The degree of colour sensation is most developed in the macula lutea, which contains only cones, and diminishes as the distance from the point increases, while it is absent in the peripheral parts of the retina.

The *rods* of the retina are said to be concerned only with the capacity to distinguish between quantitative sensations of light.

3. Hering's Theory.—Ew. Hering, in order to explain the sensation of light, proceeds from the axiom stated under 1, p. 1013. What we are conscious of, and call a visual sensation, is the psychical expression for the metabolism in the visual substance (*Sehsubstanz*), *i.e.*, in those nerve masses which are excited in the process of vision. Like every other corporeal matter, this substance during the activity of the metabolic process undergoes decomposition or "*disassimilation*;" while during rest, it must be again renewed, or "*assimilate*" new material. Hering assumes that for the perception of *white* (bright) and *black* (dark), two different qualities of the chemical processes take place in the visual substance, so that the sensation of *white* or bright corresponds to the *disassimilation* (decomposition), and that of *black* (dark) to the *assimilation* (restitution) of the visual substance. According to this view, the different degrees of distinctness or intensity with which these two sensations appear, occur in the several transitions between pure white and deep black, or the proportions in which they appear to be mixed (grey), correspond to the intensity of these two psycho-physical processes. Thus the consumption and restitution of matter in the visual substance are the primary processes in the sensation of white and black. In the production of the sensation of white, the consumption of the visual substance is caused by the vibrating ethereal waves acting as the discharging force, or stimulus, while the degree of the sensation of whiteness (brightness) is proportional to the quantity of the matter consumed. The process of restitution discharges the sensation of black; the more rapidly it occurs, the stronger is the sensation of black. The consumption of the visual substance at one place causes a greater restitution in the adjoining parts. Both processes influence each other simultaneously and conjointly. This explains physiologically the phenomenon of *contrast* (p. 1020), of which

the old view could give only a psychical interpretation. Similarly, *colour sensation* is regarded as a sensation of decomposition (disassimilation) and one of the restitution (assimilation); in addition to *white*, *red* and *yellow* are the expression of decomposition; while *green* and *blue* represent the sensation of restitution. Thus the visual substance is subject to three different ways of chemical change or metabolism. We may thus explain the *coloured* phenomena of contrast and the complementary after images. The sensation of black-white may occur simultaneously with all colours, so that every colour sensation is accompanied by that of dark or bright, so that we cannot have an absolutely pure colour. There are three different constituents of the visual substance; that connected with the sensation of black-white (colourless), that with blue-yellow, and that with red-green. All the rays of the visible spectrum act in disassimilating the black-white substance, but the different rays act in different degrees. The blue-yellow or the red-green substances, on the other hand, are disassimilated only by certain rays, some rays causing assimilation, and others are inactive. Mixed light appears colourless, when it causes an equally strong disassimilation and assimilation in the blue-yellow and in the red-green substance, so that the two processes mutually antagonise each other, and the action on the black-white substance appears pure. Two objective kinds of light, which together yield white, are not to be regarded as complementary, but as antagonistic kinds of light, as they do not supplement each other to produce white, but only allow this to appear pure, because, being antagonistic, they mutually prevent each other's action.

The imperfection of the Young-Helmholtz theory of colour sensation is that it recognises only one kind of excitability, excitement, and fatigue (corresponding to Hering's disassimilation), and that it ignores the antagonistic relation of certain light rays to the eye. It does not regard white as consisting of complementary light rays, which neutralise each other by their action on the coloured visual substance, but as uniting to form white (Hering).

In applying this theory to *colour-blindness* (§ 397), we must assume that, those who are *red-blind* want the red-green visual substance; there are but two partial spectra in their solar spectrum, the black-white and the yellow-blue. The position of green appears to such an one to be colourless; the rays of the red part of the spectrum are so far visible, as the sensation of yellow and white produced by these rays is strong enough to excite the retina. Hering divides his spectrum into a yellow and a blue half. A *violet-blind* person wants the yellow-blue visual substance; in his spectrum there are only two partial spectra, the black-white and the red-green. In cases of *complete colour-blindness*, the yellow-blue and red-green substances are absent. Hence,

such a person has only the sensation of bright and dark. The sensibility to light and the length of the spectrum are retained; the brightest part in this case, as in the normal eye, is in the yellow (Hering).

Von Kries devised the following experiment against Hering's theory:—Arrange two grey surfaces, one formed by mixing white and black, the other by yellow and blue, and let both appear equally an intense grey. On staring at a red object on these surfaces until the retina is fatigued, and until the object disappears, a grey after image appears in both cases. The mixture of yellow and blue cannot in this case have acted as to cause restitution of the red-grey substance; this is done rather by the mixed grey composed of white and black.

397. Colour-Blindness and its Practical Importance.

Causes.—By the term colour-blindness (*Dyschromatopsy*) is meant a pathological condition in which some individuals are unable to distinguish certain colours. Huddart (1777) was acquainted with the condition, but it was first accurately described by Dalton (1794), who himself was red-blind. The term colour-blindness was given to it by Brewster.

The supporters of the Young-Helmholtz theory assume that, corresponding to the paralysis of the three colour-perceiving elements of the retina, there are the following kinds of colour-blindness:—

1. *Red-blindness.*
2. *Green-blindness.*
3. *Violet-blindness.*

The highest degree being termed *complete* colour-blindness.

The supporters of E. Hering's theory of colour sensation distinguish the following kinds:—

1. **Complete Colour-blindness** (*Achromatopsy*).—The spectrum appears achromatic; the position of the greenish-yellow is the brightest, while it is darker on both sides of it. A coloured picture appears like a photograph or an engraving. Occasionally the different degrees of light intensity are perceived in one shade of colour, e.g., yellow, which cannot be compared with any other colour. O. Becker and v. Hippel observed cases of *unilateral*, congenital, complete colour-blindness, whilst the other eye was normal for colour-perception.

2. **Blue-yellow Blindness** (Stilling).—The spectrum is dichromatic, and consists only of red and green. The blue-violet end of the spectrum is usually greatly shortened. In pure cases only the red and green are correctly distinguished (Mauthner's *Erythrochloropy*), but not the other colours. Unilateral cases have been observed.

3. **Red-green Blindness.**—The spectrum is also dichromatic. Yellow and blue are correctly distinguished; violet and blue are both taken for blue. The sensations for red and green are absent altogether. There are several forms of this—(a.) *Green-blindness*, or the red-green blindness, with undiminished spectrum (Mauthner's *Xanthokyanopy*), in which bright green and dark red are confounded. In the spectrum yellow abuts directly on blue, or between the two, at most, there is a strip of grey. The maximum of brightness is in the yellow. It is often unilateral and often hereditary. (b.) *Red-blindness* (or the red-green blindness with undiminished spectrum, also called Daltonism), in which bright red and dark green are confounded. The spectrum consists of yellow and blue, but

the yellow lies in the orange. The red end of the spectrum is uncoloured, or even dark. The greatest brightness, as well as the limit between yellow and blue, lies more towards the right.

4. **Incomplete colour-blindness**, or a diminished colour sense indicates the condition in which the acuteness of colour perception is diminished, so that the colours can be detected only in large objects, or only when they are near, and when they are mixed with white they no longer appear as such. A certain degree of this form is frequent, in as far as many persons are unable to distinguish greenish-blue from bluish-green.

Acquired colour-blindness occurs in diseases of the retina and atrophy of the optic nerve (Benedict), in commencing tabes, in some forms of cerebral disease (p. 933), and intoxications. At first green-blindness occurs, which is soon followed by red-blindness. The peripheral zone of the retina suffers sooner than the central area (Schirmer). In hysterical persons, there may be intermittent attacks of colour-blindness (Charcot, Landolt); and the same occurs in hypnotised persons (p. 910).

H. Cohn found that, on heating the eyeball of some colour-blind persons, the colour-blindness disappeared temporarily. Occasionally in persons without a lens, red vision is present, and is due to unknown causes. Holmgren found that 2·7 per cent. of persons were colour-blind, most being *red* and *green* blind, and very few violet blind.

Limits of Normal Colour-blindness.—The investigations on the power of colour perception in the *normal* retina, are best carried out by means of Aubert-Förster's perimeter [or that of M'Hardy, p. 1005]. It is found that *our colour perception is complete only in the middle of the field of vision*. Around this is a middle zone, in which only blue and yellow are perceived, in which, therefore, there is red-blindness. Outside this zone, there is a peripheral girdle, where there is complete colour-blindness (p. 1008). Hence, a red-blind person is distinguished from a person with normal vision in that, the central area of the normal field of vision is absent in the former, this being rather included in the middle zone. The field of vision of a green-blind person differs from that of a person with normal vision, in that his peripheral zone corresponds to the intermediate and peripheral zones of the normal eye. The violet-blind person is distinguished by the complete absence of the normal peripheral zone. The incomplete colour-blindness of these two kinds is characterised by a uniformly diminished central field. [When very intense colours are used, such as those of the solar spectrum, the retina can distinguish them quite up to its margin (Landolt).]

In poisoning with santonin, violet-blindness (yellow vision) occurs in consequence of the paralysis of the violet perceptive retinal elements, which not unfrequently is preceded by stimulation of these elements, resulting in violet vision, *i.e.*, objects seen to be coloured violet (Hüfner). Such is the explanation of this phenomenon given by Holmgren. Max Schultze, however, referred the yellow vision, *i.e.*, seeing objects yellow, to an increase of the yellow pigment in the macula lutea.

When coloured objects are very small, and illuminated only for a short time, the normal eye first fails to perceive red (Aubert, Lamansky); hence, it appears that a stronger stimulus is required to excite the sensation of red. Brücke found that very rapidly intermittent white light is perceived as green, because the short duration of the stimulation failed to excite the elements of the retina connected with the sensation of red.

[The practical importance of colour-blindness was pointed out by George Wilson, and again more recently by Holmgren.] No person should be employed in the marine or railway service until he has been properly certified to be able to distinguish red from green.

Methods of Testing Colour-blindness.—Following Seebeck, Holmgren

used small skeins of coloured wools as the simplest material, in red, orange, yellow, greenish-yellow, green, greenish-blue, blue, violet, purple, rose, brown, grey. There are five finely graduated shades of each of the above colours. When testing a person, select only one skein—*e.g.*, a bright red or rose—from the mass of coloured wools placed in front of him, and place it aside, asking him to seek out those skeins which he supposes are nearest to it in colour.

Macé and Nacati have measured the acuteness of vision by illuminating a small object with different parts of the spectrum. They compared the observations on red- and green-blind persons, with their own results, and found that a red-blind person perceives green light much brighter than a normal person. The green-blind had an excessive sensibility for red and violet. It appears that what the colour-blind lose in perceptive power for one colour they gain for another.

398. Stimulation of the Retina.

Positive and Negative After Images—Irradiation—Contrast.

As with every other nervous apparatus, a certain but small amount of time elapses after the rays of light fall upon the eye, before the action of the light takes place, whether the light acts so as to produce a conscious impression, or produces merely a reflex effect upon the pupil. The *strength* of the impression produced depends partly and chiefly upon the excitability of the retina and the other nervous structures. If the light acts for a long time with equal intensity, the excitation, after having reached its culminating point, rapidly diminishes again, at first more rapidly, and afterwards more and more slowly.

After Images.—If the light acts on the eye for some time so as to excite the retina, and if it be suddenly withheld, the retina still remains for some time in an excited condition, which is more intense and lasts longer the stronger and the longer the light was applied, and the more excitable the condition of the retina. Thus, after every visual perception, especially if it is very distinct and bright, there remains a so-called "*after image*." We distinguish a "*positive after image*," which is an image of similar brightness and a similar colour.

"That the impression of any picture remains for some time upon the eye is a physiological phenomenon; when such an impression can be seen for a long time, it becomes pathological. The weaker the eye is the longer the image remains upon it. The retina does not recover itself so quickly, and we may regard the action as a kind of paralysis. This is not to be wondered at in the case of dazzling pictures. After looking at the sun, the image may remain on the retina for several days. A similar result sometimes occurs with pictures which are not dazzling. Busch records that the impression of an engraving, with all its details, remained on his eye for 17 minutes" (Goethe).

Experiments and Apparatus for Positive After Images.—1. When a burning stick is rapidly rotated it appears as a fiery circle.

2. The *thaumatrope* of Paris.

3. The *phänakistoscope* (Plateau) or the *stroboscopic discs* (Stampfer). Upon a disc or a cylinder, a series of objects are so depicted, that successive drawings

represent individual factors of one continuous movement. On looking through an opening at such a disc rotated rapidly, we see pictures of the different phases moving so quickly, that the one rapidly follows the one in front of it. As the impression of the one impression remains until the following one takes its place, it has the appearance as if the successive phases of the movement are continuous, and are one and the same figure. The apparatus under the name of *zoetrope*, which is extensively used as a toy, is generally stated to have been invented in 1832. It was described by Cardanus in 1550. It may be used to represent certain movements—*e.g.*, of the spermatozoa and ciliary motion (Purkinje and Valentin), the movements of the heart and those of locomotion.

4. The **colour top** contains on the sectors of its disc the colours which are to be mixed. As the colour of each sector leaves a condition of excitation for the whole duration of a revolution, all the colours must be perceived simultaneously, *i.e.*, as a mixed colour.

Negative After Images.—Occasionally, when the stimulation of the retina is strong and very intense, a “negative,” instead of a positive, after image appears. In a negative after image, the *bright* parts of the object appear *dark*, and the *coloured* parts in their corresponding *contrast colours* (p. 1011).

Examples of Negative After Images.—After looking for a long time at a dazzlingly-illuminated white window, on closing the eyes, we have the impression of a bright cross, or crosses, as the case may be, with dark panes.

Negative coloured after images are beautifully shown by Nürrenberg’s apparatus. Look steadily at a coloured surface, *e.g.*, a yellow board with a small blue square attached to the centre of its surface. A white screen is allowed to fall suddenly in front of the board—the white surface now has a bluish appearance, with a yellow square in its centre.

The usual **explanation** of dark, negative after images is that, the retinal elements are fatigued by the light, so that for some time they become less excitable, and consequently, light is but feebly perceived in the corresponding areas of the retina; hence darkness prevails.

Hering explains the dark after images as due to a process of assimilation in the black-white visual substance. In explaining *coloured* after images, the Young-Helmholtz theory assumes that, under the action of the colour, *e.g.*, red, the retinal elements connected with the perception of this colour are paralysed. On now looking suddenly on a white surface, the mixture of all the colours appears as white minus red, *i.e.*, the white appears *green*. In bright daylight the contrast colour lies very near the complementary colour. According to Hering, the contrast after image is explained by the assimilation of the corresponding coloured visual substance, in this case, of the “red-green” (p. 1016, 3).

Not unfrequently, after intense stimulation of the retina, positive and negative after images *alternate* with each other until they gradually fuse. After looking at the dark red setting sun, we see alternate discs of red and green.

The phenomena of contrast undergo some modification in the peripheral areas of the retina, owing to the partial colour-blindness which occurs in these areas (Adamüch and Woinow).

Irradiation is the term applied to certain phenomena where we form a false estimate of visual impressions, owing to *inexact accommodation*.

If from inexact accommodation the margins of the object are projected upon the retina in diffusion circles, the mind tends to add the undefined margin to those parts of the visual image which are most prominent in the image itself. What is *bright* appears larger, and overcomes what is dark, while an object, without reference to brightness or colour, has the same relation to its back-ground. When the accommodation is quite accurate, the phenomenon of irradiation is not present.

“A dark object appears smaller than a bright one of the same size. On looking at the same time from a certain distance at two circles of the same size, a white one on a black back-ground, and a black on a white back-ground, we estimate the latter to be about one-fifth less than the former. On making the black circle one-fifth larger they will appear equal. Tycho de Brahe remarks that the moon, when in conjunction (dark), appears to be one-fifth smaller than in opposition (full, bright). The first lunar crescent appears to belong to a larger disc than the dark one adjoining it, which can occasionally be distinguished at the time of the new light. Black clothes make persons appear to be much smaller than light clothes. A light seen behind a margin gives the appearance of a cut in the margin. A ruler, behind which is placed a lighted candle, appears to the observer to have a notch in it. The sun, when rising and setting, appears to make a depression in the horizon” (Goethe).

Simultaneous Contrast.—By this term is meant a phenomenon like the following:—When *bright* and *dark* parts are present in a picture at the same time, the bright (white) parts always appear to be more intensely bright the less white there is near them, or, what is the same thing, the darker the surroundings, and, conversely, they appear less bright the more white tints that are present near them. A similar phenomenon occurs with *coloured* pictures. A colour in a picture appears to us to be more intense the less of this colour there is in the adjoining parts, that is, the more the surroundings resemble the tints of the contrast colour. Simultaneous contrast arises from simultaneous impressions occurring in two adjoining and different parts of the retina.

Examples of Contrast for Bright and Dark.—1. Look at a white network on a black ground; the parts where the white lines intersect appear darker, because there is least black near them.

2. Look at a point of a small strip of dark grey paper in front of a dark black back-ground. Push a large piece of white paper between the strip and the back-ground; the strip on the white ground now appears to be much darker than before. On again removing the white paper, the strip at once again appears bright (Hering).

3. Look with both eyes towards a greyish-white surface, *e.g.*, the ceiling of a room. After gazing for some time, place in front of the eye a paper tube eight inches long, and an inch to an inch and a quarter in diameter, blackened in the inside. The part of the ceiling seen through the tube appears as a round white spot (Landois).

Examples for Colours.—1. Place a piece of grey paper on a red, yellow, or

blue ground; the contrast colours appear at once—viz., green, blue, or yellow. The phenomenon is made still more distinct by covering the whole with transparent tracing paper (Herm. Meyer). Under similar circumstances, printed matter on a coloured ground appears in its complementary colour (W. v. Bezold).

2. An air bubble in the strongly tinged field of vision of a thick microscopical preparation appears with an intense contrast colour (Landois).

3. Paste four green sectors upon a rotatory white disc, leave a ring round the centre of the disc uncovered by green, and cover it with a black strip. On rotating such a disc, the black part appears red and not grey (Brücke).

4. Look with both eyes towards a greyish-white surface, and place in front of one eye a tube, about the length and breadth of a finger, composed of transparent oiled paper, gummed together to such thickness as will permit light to pass through its walls. The part of the surface seen through the tube appears in its contrast colour. The experiment also shows the contrast in the intensity of the illumination (Landois). A white piece of paper, with a round black spot in its centre, when looked at through a blue glass appears blue with a black spot. If a white spot of the same size on a black ground be placed in front, so that it is reflected in the glass plate, and just covers the black spot, it shows the contrast colour yellow (Ragona Scina).

5. The *coloured shadows* also belong to the group of simultaneous contrasts. "Two conditions are necessary for the production of coloured shadows—firstly, that the light gives some kind of a colour to the white surface; second, that the shadow is illuminated, to a certain extent, by another light. During the twilight, place a short lighted candle on a white surface, between it and the fading daylight hold a pencil vertically, so that the shadow thrown by the candle is illuminated, but not abolished, by the feeble daylight; the shadow appears of a beautiful *blue*. The blue shadow is easily seen, but it requires a little attention to observe that the white paper acts like a reddish-yellow surface, whereby the blue colour apparent to the eye is improved. One of the most beautiful cases of coloured shadows is seen in connection with the full moon. The light of the candle and that of the moon can be completely equalised. Both shadows can be obtained of equal strength and distinctness, so that both colours are completely balanced. Place the plate opposite the light of the moon, the lighted candle a little to one side at a suitable distance. In front of the plate hold an opaque body, when a double shadow appears, the one thrown by the moon and lighted by the candle being bright reddish-yellow; and, conversely, the one thrown by the candle and lighted by the moon appears of a beautiful blue. Where the two shadows come together and unite is black" (Goethe).

6. "Take a plate of green glass of considerable thickness, and hold it so as to get the bars of a window reflected in it, the bars will be seen double; the image formed by the under surface of the glass being *green*, while the image coming from the under surface of the glass, and which ought really to be colourless, appears to be purple. The experiment may be performed with a vessel filled with water, with a mirror at its base. With pure water colourless images are obtained, while by colouring the water coloured images are produced" (Goethe).

Explanation of Contrast.—Some of these phenomena may be explained as due to an error of judgment. During the simultaneous action of several impressions, the judgment errs, so that when an effect occurs at one place, this acts to the slightest extent in the neighbouring parts. When, therefore, brightness acts upon a part of the retina, the judgment ascribes the smallest possible action of the brightness to the adjoining parts of the retina. It is the same with colours. It is far more probable that the phenomena are to be referred to actual physiological processes (Hering).

Partial stimulation with light affects not only the part so acted on, but also the surrounding area of the retina; the part directly excited undergoing increased

disassimilation, the (indirectly stimulated) adjoining area undergoing increased *assimilation*; the increase of the latter is greatest in the immediate neighbourhood of the illuminated portion, and rapidly diminishes as the distance from it increases. By the increase of the assimilation in those parts not acted on by the image of the object, this is prevented, so that the diffused light is perceived. The increase of the assimilation in the immediate neighbourhood of the illuminated spot is greatest, so that the perception of this relatively stronger different light is largely rendered impossible (Hering).

Successive Contrast.—Look for a long time at a dark or bright object, or at a coloured (*e.g.*, red) one, and then allow the effect of the contrast to occur on the retina—*i.e.*, with reference to the above, bright and dark, or the contrast colour green, then these become very intense. This phenomenon has also been called "*successive contrast*." In this case the negative after image obviously plays a part.

399. Movements of the Eyeballs and the Eye-Muscles.

The globular eyeball is capable of extensive and free movement on the correspondingly excavated fatty pad of the orbit, just like the head of a long bone in the corresponding socket of a freely movable arthro-dial joint. The movements of the eyeball, however, are limited by certain conditions, by the mode in which the eye-muscles are attached to it. Thus, when one muscle contracts, its antagonistic muscle acts like a bridle, and so limits the movement; the movements are also limited by the insertion of the optic nerve. The soft elastic pad of the orbit on which the eyeball rests is itself subject to be moved forward or backward, so that the eyeball also must participate in these movements.

Protrusion of the eyeball takes place—1. By congestion of the blood-vessels, especially of the veins in the orbit, such as occurs when the outflow of the venous blood from the head is interfered with, as in cases of hanging. 2. By contraction of the smooth muscular fibres in Tenon's capsule (p. 795), in the sphenomaxillary fissure and in the eyelids (§ 404), which are innervated by the cervical sympathetic nerve. 3. By voluntary forced opening of the palpebral fissure, whereby the pressure of the eyelids acting on the eyeball is diminished. 4. By the action of the oblique muscles, which act by pulling the eyeball inwards and forwards. If the superior oblique be contracted when the eyelids are forcibly opened, the eyeball may be protruded about 1 mm. When protrusion of the eyeball occurs pathologically (as in 1 and 2), the condition is called **exophthalmos**.

Retraction of the eyeball is the opposite condition, and is caused—1. By closing the eyelids forcibly. 2. By an empty condition of the retrobulbar blood-vessels, diminished succulence, or disappearance of the tissue of the orbit. 3. Section of the cervical sympathetic in dogs causes the eyeball to sink somewhat in the orbit. The smooth muscular fibres of Tenon's capsule are perhaps antagonistic in their action to the four recti when acting together, and thus prevent the eyeball from being drawn too far backwards. Many animals have a special *retractor bulbi* muscle, *e.g.*, amphibians, reptiles, and many mammals; the ruminants have four.

The movements of the eyes are almost always accompanied by

similar movements of the head, chiefly on looking upwards, less so on looking laterally, and least of all when looking downwards.

The difficult investigations on the movements of the eyeballs have been carried out, especially by Listing, Meissner, Helmholtz, Donders, A. Fick, and E. Hering.

Axis.—All the movements of the eyeball take place round its *point of rotation* (Fig. 417, *o*), which lies 1.77 mm. behind the centre of the visual axis, or 10.957 mm. from the vertex of the cornea (Donders). In order to determine more carefully the movements of the eyeball, it is necessary to have certain definite data:—1. The *visual axis* (*S, S'*), or the antero-posterior axis of the eyeball, unites the point of rotation with the fovea centralis, and is continued straight forwards to the vertex of the cornea. 2. The *transverse*, or horizontal axis (*Q, Q'*), is the straight line connecting the points of rotation of both eyes and its extension outwards. Of course, it is at right angles to 1. 3. The *vertical axis* passes vertically through the point of rotation at right angles to 1 and 2. These three axes form a co-ordinate system. We must imagine that in the orbit there is a fixed determinate axial system, whose point of intersection corresponds with the point of rotation of the eyeball. When the eye is at rest (primary position), the three axes of the eyeball completely coincide with the three axes of the co-ordinate system in the orbit. When the eyeball however is moved, two or more axes are displaced from this, so that they must form angles with the fixed orbital system.

Planes.—In order to be more exact, and also partly for further estimations, let us suppose three *planes* passing through the eyeball, and that their position is secured by any two axes. 1. The *horizontal plane* divides the eyeball into an upper and lower half; it is determined by the visual transverse axes. In its course through the retina it forms the horizontal line of separation of the latter; the coats of the eyeball itself cut it in their horizontal meridian. 2. The *vertical plane* divides the eyeball into an inner and outer half; it is determined by the visual and vertical axes. It cuts the retina in the vertical line of separation of the latter and the periphery of the bulb in the vertical meridian of the eyeball. 3. The *equatorial plane* divides the eyeball into an anterior and posterior half; its position is determined by the vertical and transverse axes, and it cuts the sclerotic in the equator of the eyeball. The horizontal and vertical lines of separation of the retina, which intersect in the fovea centralis, divide the retina into four quadrants.

In order to define more precisely the movements of the eyeball, v. Helmholtz has introduced the following terms:—He calls the straight line which connects the point of rotation of the eye with the fixed point in the outer world, the *visual line* ("Blicklinie"), while a

plane passing through these lines in both eyes, he called the *visual plane*; the *ground line* of this plane is the line uniting the two points of rotation—viz., the transverse axis of the eyeball. Suppose a sagittal section to be made through the head, so as to divide the latter into a right and left half, then this plane would halve the ground line of the visual plane, and when prolonged forward would intersect the visual plane in the median line. The visual point of the eye can be (1) raised or lowered—the field which it traverses being called the visual field (“Blickfeld”); it is part of a spherical surface with the point of rotation of the eye in its centre. Proceeding from the primary position of both eyes, which is characterised by both visual lines being parallel with each other and horizontal, then the elevation of the visual plane can be determined by the angle which this forms with the plane of the primary position. This angle is called the *angle of elevation*—it is positive when the visual plane is raised (to the forehead), and negative when it is lowered (chinwards). (2) From the primary position, the visual line can be turned laterally in the visual plane. The extent of this lateral deviation is measured by the angle of lateral rotation—*i.e.*, by the angle which the visual line forms with the median line of the visual plane; it is said to be positive when the posterior part of the visual line is turned to the right, negative when to the left. The following are the positions of the eyeball:—

1. **Primary position**, in which both the lines of vision are parallel with each other, and the visual planes are horizontal. The three axes of the eyeball coincide with the three fixed axes of the co-ordinate system in the orbit.

2. **Secondary positions** are due to movements of the eye from the primary position. There are two different varieties—(a) where the visual lines are parallel, but are directed *upwards* or *downwards*. The transverse axis of both eyes remains the same as in the primary position; the deviations of the other two axes are expressed by the amount of the angle of elevation of the line of vision. (b) The second variety of the secondary position is produced by the *convergence* or *divergence* of the lines of vision. In this variety the vertical axes, round which the lateral rotation takes place, remain as in the primary position; the other axes form angles; the amount of the deviation is expressed by the “angle of lateral rotation.” The eye, when in the primary position, can be rotated from this position 42° outwards, 45° inwards, 34° upwards, and 57° downwards (Schuermann).

3. **Tertiary position** is the position brought about by the movements of the eye, in which the lines of vision are *convergent*, and are at the same time *inclined* upwards or downwards.

All three axes of the eye are no longer coincident with the axes in

the primary position. The exact direction of the visual lines is determined by the amount of the angle of lateral rotation and the angle of elevation. There is still another important point. The eyeball is always rotated at the same time round the line of vision and round its axis (Volkmann, Hering, Donders). As the iris rotates round the visual line like a wheel round its axis, this rotation is called "circular rotation" ("*Raddrehung*") of the eye, which is always connected with the tertiary positions. Even oblique movement may be regarded as composed of—(1) a rotation round the vertical axis, and (2) round the transverse axis; or it may be referred to rotation round a single constant axis placed between the above-named axes, passing through the point of rotation of the eyeball, and at right angles to the secondary and primary direction of the visual axis (line of vision)—(Listing). The amount of circular rotation is measured by the angle which the horizontal separation line of the retina forms with the horizontal separation line of the retina of the eye in the primary position. This angle is said to be positive, when the eye itself rotates in the same direction as the hand of a watch observed by the same eye—*i.e.*, when the upper end of the vertical line of separation of the retina is turned to the right.

According to Donders, the angle of rotation increases with the angle of elevation and the angle of lateral rotation—it may exceed 10° . With equally great elevation or depression of the visual plane, the rotation is greater, the greater the elevation or depression of the line of vision.

On looking *upwards* in the tertiary position, the upper ends of the vertical lines of separation of the retina *diverge*; on looking downwards they converge. If the visual plane be raised, the eye, when it deviates laterally to the right, makes a circular rotation to the left. When the visual plane is depressed, on deviating the eye to the right or left, there is a corresponding circular rotation to the right or left. Or we may express the result thus: When the angle of elevation and the angle of deviation have the same sign (+ or -), then the rotation of the eyeball is negative; when, however, the signs are unequal, the rotation is positive. In order to make the circular rotation visible in one's own eyes, accommodate one eye for a surface divided by vertical and horizontal lines until a positive after image is produced, and then rapidly rotate the eye into the third position. The lines of the after image then form angles with the lines of the back-ground. As the position of the vertical meridian of the eye is important from a practical point of view, it is important to note that, in the primary and secondary positions of the eyes, the vertical meridian retains its vertical position. On looking to the left and upwards, or to the right and downwards, the vertical meridians of both eyes are turned to the left; conversely, they are turned to the right on looking to the left and downwards, or to the right and upwards.

In the secondary positions of the eye, rotation of the axis of the eye never occurs (Listing). Very slight rolling of the eyes occurs, however, when the head is inclined towards the shoulder, and in the direction opposite to that of the head (Javal)—it is about 1° for every 10° of inclination of the head (Skrebitzky, Nagel).

Ocular Muscles.—The movements of the eyeball are accomplished by means of the four straight and two oblique ocular muscles. In order to understand the action of each of these muscles, we must know the plane of traction of the muscles and the axis of rotation of the eyeball. The *plane of traction* is found by the plane lying in the middle of the origin and insertion of the muscle and the point of rotation of the eyeball. The *axis of rotation* is always at right angles to the plane of traction in the point of rotation of the eyeball.

The rectus internus (I) and externus (E) rotate the eye almost exactly inwards and outwards (Fig. 417). The plane of traction lies in the

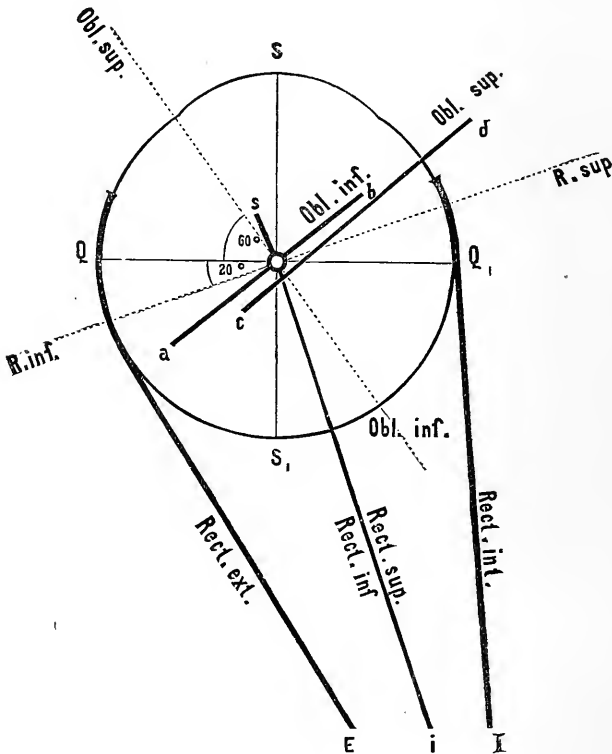

Fig. 417.

Scheme of the action of the ocular muscles.

plane of the paper; Q, E is the direction of the traction of the external rectus, Q₁, I, that of the internal. The axis of rotation is in the point of rotation, O, at right angles to the plane of the paper, so that it coincides with the vertical axis of the eyeball. 2. The axis of rotation of the R. superior and inferior (the dotted line, R. sup., R. inf.), lies in

the horizontal plane of separation of the eye, but it forms an angle of about 20° with the transverse axis (Q, Q_1); the direction of the traction for both muscles is indicated by the line, s, i . By the action of these muscles, the cornea is turned upwards and slightly inwards, or downwards and slightly inwards. 3. The axis of rotation of both oblique muscles (the dotted lines, *Obl. sup.* and *Obl. inf.*) also lies in the horizontal plane of separation of the eyeball, and it forms an angle of 60° with the transverse axis. The direction of the traction of the *inferior* oblique gives the line, a, b ; that of the *superior*, the line, c, d . The action of these muscles, therefore, is, in the one case, to rotate the cornea outwards and upwards, and, in the other, outwards and downwards. These actions, of course, only obtain when the eyes are in the primary position—in every other position the axis of rotation of each muscle changes.

When the eyes are at rest, the muscles are in equilibrium. Owing to the power of the internal recti, the visual axes converge and would meet, if prolonged 40 centimetres in front of the eye. In the movements of the eyeball, one, two, or three muscles may be concerned. *One* muscle acts only when the eye is moved directly outwards or inwards, especially the internal and external rectus. *Two* muscles act when the eyeball is moved directly upwards (superior rectus and inferior oblique) or downwards (inferior rectus and superior oblique). *Three* muscles are in action when the eyeballs take a diagonal direction, especially for *inwards* and *upwards*, by the internal and the superior rectus and inferior oblique; for *inwards* and *downwards*, the internal and inferior rectus and superior oblique; for *outwards* and *downwards*, the external and inferior rectus and superior oblique; for *outwards* and *upwards*, the external and superior rectus and inferior oblique.

[The following table shows the action of the muscles of the eyeball:—

MOVEMENTS PRODUCED BY THE OCULAR MUSCLES.

<i>Inwards</i> . . .	Rectus internus.		<i>Inwards and downwards</i> . . .	{ Rectus internus. Rectus inferior. Obliquus superior.
<i>Outwards</i> . . .	Rectus externus.			<i>Outwards and upwards</i> . . .
<i>Upwards</i> . . .	{ Rectus superior. Obliquus inferior.			<i>Inwards and downwards</i> . . .
<i>Downwards</i> . . .	{ Rectus inferior. Obliquus superior.			<i>Outwards and upwards</i> . . .
<i>Inwards and upwards</i> . . .	{ Rectus internus. Rectus superior. Obliquus inferior.			<i>Outwards and downwards</i> . . .

Ruete imitated the movements of the eyeballs by means of a model, which he called the *ophthalmotrope*.

The size of the eyeball and its length diminish with age. The mobility is less in the vertical than in the lateral direction, and less upwards than downwards. The normal and myopic eye can be moved more outwards, and the long-sighted eye more inwards. The external and internal rectus act most when the eye is moved outwards, the obliqui when it is rotated inwards. An eye can be turned inwards to a greater extent when the other eye at the same time is turned outwards, than when the other is turned inwards. During near vision, the right eye can be turned less to the right, and the left to the left, than during distant vision (Hering).

Simultaneous Ocular Movements.—Both eyes are always moved simultaneously. Even when one eye is quite blind, the ocular muscles move when the whole eyeball is excited. When the head is straight, the movements always take place so that both visual planes (visual axes) lie in the same plane. In front both visual axes can diverge only to a trifling extent, while they can converge considerably. If individual ocular muscles are paralysed, the position of the visual axes in the same plane is disturbed, and *squinting* results, so that the patient no longer can direct both visual axes simultaneously to the same point, but he directs the one eye after the other. Even nystagmus (p. 941) occurs in both eyes simultaneously, and in the same direction. The innate, simultaneous movement of both eyes is spoken of as an *associated movement* (Joh. Müller). E. Hering showed that, in all ocular movements, there is a *uniformity of the innervation* as well. Even during such movements, in which one eye apparently is at rest, there is a movement, due to the action of two antagonistic forces, the movements resulting in a slight to and fro motion of the eyeball.

The **motor nerves** of the ocular muscles are the oculomotorius (§ 345), the trochlearis (§ 346), and the abducens (§ 348). The centre lies in the corpora quadrigemina (§ 379), and partly in the medulla oblongata (§ 379).

400. Binocular Vision.

Advantages.—Vision with both eyes affords the following advantages:—1. The *field of vision* of both eyes is considerably larger than that of one eye. 2. The perception of *depth* is rendered easier, as the retinal images are obtained from two different points. 3. A more exact estimate of the *distance* and *size* of an object can be formed, in consequence of the perception of the degree of convergence of both eyes. 4. The *correction of certain errors* in the one eye is rendered possible by the other.

When the position of the head is *fixed*, we can easily form a conception as to the *form of the entire field of vision* if we close one eye and direct the open eye inwards.

We observe that it is pear-shaped, broad above and smaller below, the silhouette, or profile of the nose, causes the depression between the upper and lower part of the field.

401. Single Vision—Identical Points of the Retina —Horofter.

Identical Points.—If we imagine the retinae of both eyes to be a pair of hollow saucers placed one within the other, so that the yellow spots of both eyes coincide, and also the similar quadrants of the retinae, then all those points of both retinae which coincide or cover each other are called "*identical*," or "*corresponding*" points of the retina. The two meridians which separate the quadrants coinciding with each other are called the "*lines of separation*." Physiologically, the identical points are characterised by the fact that, when they are both simultaneously excited by light, the excitement proceeding from them is, by a psychical act, referred to one and the same point of the field of vision, lying, of course, in a direction through the nodal point of each eye. Stimulation of *both* identical points causes only *one* image in the field of vision. Hence, all those objects of the external world, whose rays of light pass through the nodal points to fall upon identical points of the retina, are seen *singly*, because their images from both eyes are referred

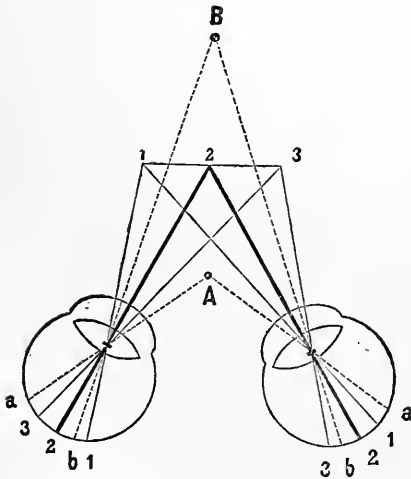

Fig. 418.

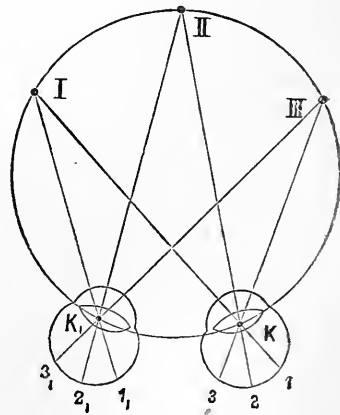

Fig. 419.

Scheme of identical and non-identical points of the retina.

Horofter for the secondary position, with convergence of the visual axes.

to the same point of the field of vision, so that they cover each other. All other objects whose images do not fall upon identical points of the retina cause "double vision," [or diplopia].

Proofs.—If we look at a linear object with the points 1, 2, 3, then the corresponding retinal images are 1, 2, 3 and 1, 2, 3, which are obviously identical points of the retina (Fig. 418.) If, while looking at this line, there be a point, A, nearer the eyes, or B, further from them, then, on focussing for 1, 2, 3, neither the rays (A, a, A, a) coming from A, nor those (B, b, B, b) from B, fall upon identical points; hence, A and B appear double.

Make a point (*e.g.*, 2) with ink on paper; of course the image will fall upon both foveæ centrales of the retina (2, 2), which, of course, are identical points. Now press laterally upon one eye, so as to displace it slightly, then two points at once appear, because the image of the point no longer falls upon the fovea centralis of the displaced eye, but on an adjoining non-identical part of the retina. When we squint voluntarily all objects appear double.

The vertical surfaces of separation of the retina do not exactly coincide with the *vertical meridians*. There is a certain amount of divergence (0.5° – 3°), less above, which varies in different individuals, and it may be in the same individual at different times (Hering, Donders). The horizontal lines of separation, however, coincide. Images which fall upon the vertical lines of separation appear to be vertical to those on the horizontal lines, although they are not actually so. Hence, the vertical lines of separation are the *apparent* vertical meridians. Some observers regard the identical points of the retina as an *acquired* arrangement; others regard it as normally *innate*. Persons who have had a squint from their birth see singly; in these cases the identical points must be differently disposed.

The **horopter** represents all those points of the outer world from which rays of light passing into both eyes fall upon identical points of the retina, the eyes being in a certain position. It varies with the different positions of the eyes.

1. In the **primary position** of both eyes with the visual axes parallel, the rays of direction proceeding from two identical points of the two retinae, are parallel and intersect only at infinity. Hence, for the primary position, the horopter is a plane in infinity.

2. In the **secondary position** of the eyes with converging visual axes, the horopter for the transverse lines of separation is a circle which passes through the nodal points of both eyes (Fig. 419, K, K,) and through the fixed points I, II, III (Joh. Müller). The horopter of the vertical lines of separation is in this position vertical to the plane of vision.

3. In the **symmetrical tertiary position**, in which the horizontal and vertical lines of separation form an angle, the horopter of the vertical lines of separation is a straight line inclined towards the horizon. There is no horopter for the identical points of the horizontal lines of separation, as the lines of direction prolonged from the identical points of these points do not intersect.

4. In the unsymmetrical tertiary position (with rolling) of the eyes, in which the fixed point lies at unequal distances from both nodal points, the horopter is a curve of a complex form.

All objects, the rays proceeding from which fall upon *non-identical* points of the retina, appear *double*. We can distinguish *direct* or *crossed* double images, according as the rays prolonged from the non-identical points of the retina intersect *in front* of or *behind* the fixed point.

Experiment.—Hold two fingers—the one behind the other—before both eyes. Accommodate for the far one, and then the near one appears double, and when we accommodate for the near one, the far one appears double. If, when accommodating for the near one, the right eye be closed, the left (crossed) image of the far finger disappears. On accommodating for the far finger and closing the right eye, the right (direct) double image of the near finger disappears.

Double images are referred to the proper distance from the eyes, just as single images are.

Neglect of Double Images.—Notwithstanding the very large number of double images which must be formed during vision, they do not disturb vision. As a general rule, they are “neglected,” so that the attention must, as a rule, be directed to them before they are perceived. This condition is favoured thus:—

1. The attention is always directed to the point of the field of vision, which is accommodated for at the time. The image of this part is projected on to both yellow spots, which are identical points of the retina.

2. The form and colour of objects on the lateral parts of the retina are not perceived so sharply.

3. The eyes are always accommodated for those points which are looked at. Hence, indistinct images with diffusion circles are always formed by those objects which yield double images, so that they can be more readily neglected.

4. Many double images lie so close together that the greater part of them, when the images are large, covers the other.

5. By practice images which do not exactly coincide may be united.

402. Stereoscopic Vision.

On looking at an object, both eyes do not yield exactly similar images of that object—the images are slightly different, because the two eyes look at the object from two different points of view. With the right eye we can see more of the side of the body directed towards it, and the same is the case with the left eye. Notwithstanding this

inequality, the two images are united. How two different images are combined is best understood by analysing the stereoscopic images.

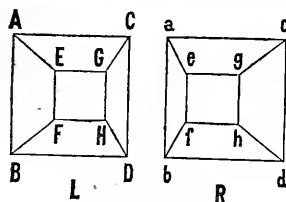

Fig. 420.

Two Stereoscopic Drawings.

Let, in Fig. 420, L and R represent two such images as are obtained with the left and right eyes. These images, when seen with a stereoscope, look like a truncated pyramid, which projects towards the eye of the observer, as the points indicated by the same signs cover each other. On measuring the distance of the points which coincide or cover each other in both figures, we find that the distances A, a, B, b, C, c, D, d are equally great, and at the same time are the *widest* of all the points of both figures; the distances E, e, F, f, G, g, H, h, are also equal, but are *smaller* than the former. On looking at the coinciding lines (A, E, a, e, and B, F, b, f) we observe that, all the points of this line which lie nearer to A, a, and B, b, are further apart than those lying nearer E, e, and F, f.

Comparing these results with the stereoscopic image, we have the following laws for stereoscopic vision:—1. All those points of two stereoscopic images, and, of course, of two retinal images of an object, which in both images are equally distant from each other, appear on the same plane. 2. All points which are nearer to each other, compared with the distance of other points, appear to be nearer to the observer. 3. Conversely, all points which lie further apart from each other appear perspective in the back-ground.

The cause of this phenomenon lies in the fact that, “in vision with both eyes we constantly refer the position of the individual images in the direction of the visual axis to where they both intersect.”

Proofs.—The following stereoscopic experiment (Fig. 421) proves this:—Take both images of two pairs of points (α , β , and α , β), which are at unequal distances from each other on the surface of the paper. By means of small stereoscopic prisms cause them to coincide, then the combined point, A of α , and α appears at a distance on the plane of the paper, while the other point, B, produced by the superposition of β and β , floats in the air before the observer. Fig. 421 shows how this occurs. The following experiment shows the same result:—Draw two figures, which are to be superposed similar to the lines B, A, A, E, β , α , and α , e, in Fig. 420. In the lines B, A, and β , α , all the points which are to be superposed lie equally distant from each other, while, on the contrary, all the points in A, E, and α , e, which lie nearer E and e, are constantly nearer to each other. When looked at with a stereoscope, the superposed verticals, A, e, and B, β , lie in the plane of the paper, while the superposed lines, A, α , and E, e, project obliquely towards the observer from the plane of the paper. From these two fundamental experiments we may analyse all pairs of stereoscopic pictures. Thus, in Fig. 420, if we exchange the two pictures, so that R lies in the place of L, then we must obtain the impression of a truncated hollow pyramid.

Two stereoscopic pictures, which are so constructed that the one contains the body from the front and above, and the other, it from the front and below (suppose in Fig. 420 the lines A B, and α β , were the ground lines), can never be superposed by means of the stereoscope.

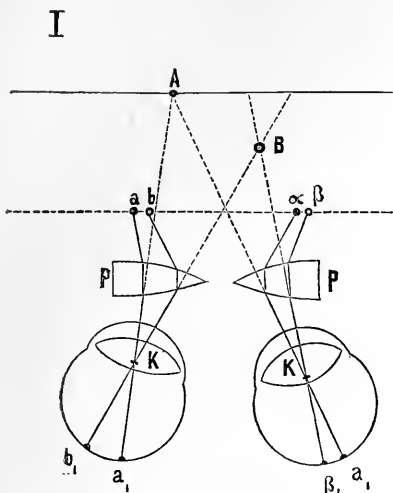

Fig. 421.

Scheme of Brewster's Stereoscope.

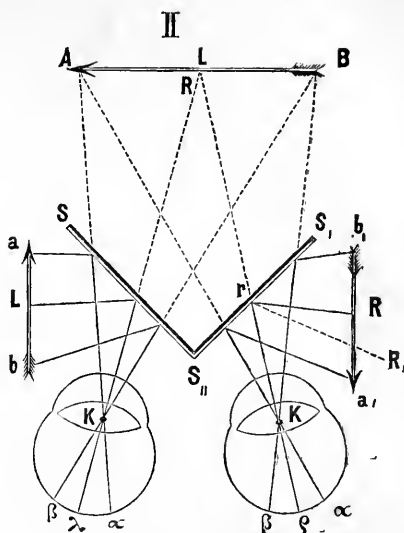

Fig. 422.

Wheatstone's Stereoscope.

This process has been explained in another way. Of the two figures, R and L (Fig. 420), only A B C D, and a b c d, fall upon identical points of the retina, hence these alone can be superposed; or, when there is a different convergence of the visual axis, only E F G H, and e f g h, can be superposed for the same reason. Suppose the square ground surfaces of the figures are first superposed, in order to explain the stereoscopic impression, it is further assumed that both eyes, after superposition of the ground squares, are rapidly moved towards the apex of the pyramid. As the axes of the eyes must thereby converge more and more, the apex of the pyramid appears to project; as all points which require the convergence of the eyes for their vision appears to us to be nearer (see below). Thus, all corresponding parts of both figures would be brought, one after the other, upon identical points of the retina by the movements of the eyes (Brücke).

It has been urged against this view that the duration of an electrical spark suffices for stereoscopic vision (Dove)—a time which is quite insufficient for the movements of the eyes. Although this may be true for many figures, yet in the correct combination of complex or extraordinary figures, these movements of the visual axes are not excluded, and in many individuals they are distinctly advantageous. Not only the actual movements necessary for this act, but the sensations derived from the muscles are also concerned.

When two figures are *momentarily* combined to form a stereoscopic picture, there being no movement of the eyes, clearly many points in the stereoscopic pictures are superposed which, *strictly* speaking, do not fall upon identical points of the retina. Hence, we cannot characterise the identical points of the retina as coinciding mathematically (p. 1029); but, from a physiological point of view, we must regard such points as identical which, *as a rule*, by simultaneous stimulation, give rise to a single image. The mind obviously plays a part in this combination of images. There is a certain psychical tendency to fuse the double images on the retinae into one image, in accordance with the fact that we, from experience, recognise the existence of a single object. If the differences between two stereoscopic pictures be too great, so that parts of the retina too wide apart are excited thereby, or when new lines are present in a picture, and do not admit of a stereoscopic effect, or disturb the combination, then the stereoscopic effect ceases.

The **stereoscope** is an instrument by means of which two somewhat similar pictures drawn in perspective may be superposed so that they appear single. Wheatstone (1838) obtained this result by means of two mirrors placed at an angle (Fig. 422); Brewster (1843) by two prisms (Fig. 421). The construction and mode of action are obvious from the illustrations.

Some pairs of two such pictures may be combined, without a stereoscope, by directing the visual axis of each eye to the picture held opposite to it.

Two completely identical pictures, *i.e.*, in which all corresponding points have exactly the same relation to each other as the same sides of two copies of a book, appear quite flat under the stereoscope; as soon, however, as in one of them one or more points alters its relation to the corresponding points, this point either projects or recedes from the plane.

Telestereoscope.—When objects, placed at a great distance, are looked at, *e.g.*, the most distant part of a landscape, they appear to us to be flat, as in a picture,

and do not stand out, because the slight differences of position of our eyes in the head are not to be compared with the great distance. In order to obtain a stereoscopic view of such objects, v. Helmholtz constructed the *Telestereoscope* (Fig. 423), an apparatus which, by means of two parallel mirrors,

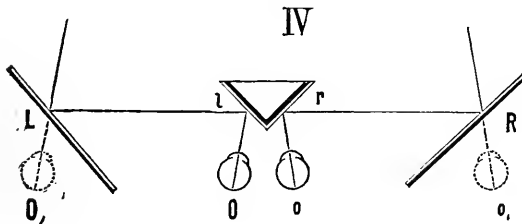

Fig. 423.

Telestereoscope of v. Helmholtz.

places, as it were, the point of view of both eyes wider apart. Of the mirrors, L and R, each projects its image of the landscape upon *l* and *r*, to which both eyes, O, o, are directed. According to the distance between L and R, the eyes, O, o, as it were, are displaced to O₁, o₁. The distant landscape appears like a stereoscopic view. In order to see distant parts more clearly and nearer, a double telescope or opera-glass may be placed in front of the eyes (p. 1037).

Take two corresponding stereoscopic pictures, with the surfaces black in one

case and light in the other. Draw two truncated pyramids like Fig. 420, make one figure exactly like L, *i.e.*, with a white surface and black lines, and the other with white lines and a black surface, then under the stereoscope such objects *glance*. The causing of the glancing condition is that the glancing body at a certain distance reflects bright light into one eye and not into the other, because a ray reflected at an angle cannot enter both eyes simultaneously (Dove).

Wheatstone's Pseudoscope consists of two right-angled prisms (Fig. 424, A and B) enclosed in a tube, through which we can look in a direction parallel with the surfaces of the hypoteneuses. If a spherical surface be looked at with this instrument, the image formed in each eye is inverted laterally. The right eye sees the view usually obtained by the left eye, and conversely; the shadow which the body in the light throws upon a light ground is reversed. Hence the ball appears hollow.

Contest of the Fields of Vision.—The stereoscope is also useful for the following purpose:—In vision with both eyes, both eyes are almost never active simultaneously and to the same extent; both undergo variations, so that first the impression on the one retina and then that on the other is stronger. If two different surfaces be placed in a stereoscope, then, especially when they are luminous, these two alternate in the general field of vision, according as one or other eye is active (Panum). Take two surfaces with lines ruled on them, so that when the surfaces are superposed, the lines will cross each other, then either the one or the other system of lines is more prominent (Panum). The same is true with coloured stereoscopic figures, so that there is a contest of the coloured fields of vision.

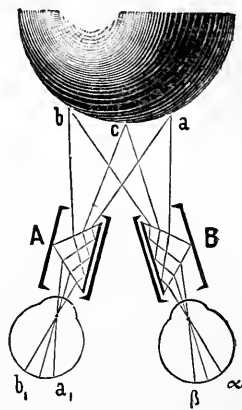

Fig. 424.

Wheatstone's Pseudoscope.

403. Estimation of Size and Distance—False Estimates of Size and Direction.

Size.—We estimate the size of an object—apart from all other factors—from the *size of the retinal image*; thus, the moon is estimated to be larger than the stars. If, while looking at a distant landscape, a fly should suddenly pass across our field of vision, near to our eye, then the image of the fly, owing to the relatively great size of the retinal image, may give one the impression of an object as large as a bird. If, owing to defective accommodation, the image gives rise to diffusion circles, the size may appear to be even greater. But, objects of very unequal size give equally large retinal images, especially if they are placed at such a distance that they form the same *visual angle* (Fig. 385); so that in estimating the *actual size* of an object, as opposed to the *apparent size*

determined by the visual angle, the *estimate of distance* is of the greatest importance.

As to the distance of an object, we obtain some information from the *feeling of accommodation*, as a greater effort of the muscle of accommodation is required for exact vision of a near object than for seeing a distant one. But, as with two objects at unequal distances giving retinal images of the *same size*, we know from experience that that object is smaller which is near, then that object is estimated to be the smaller, for which, during vision, we must accommodate more strongly.

In this way we explain the following:—A person beginning to use a microscope always observes with the eyes accommodated for a near object, while one used to the microscope looks through it without accommodating. Hence, beginners always estimate microscopic objects as too small, and on making a drawing of them it is too small. If we produce an after image in one eye, it at once appears smaller on accommodating for a near object, and again becomes larger during negative accommodation. If we look with one eye at a small body placed as near as possible to the eye, then a body lying behind it, but seen only indirectly, appears smaller.

Angle of Convergence of Visual Axes.—In estimating the *size* of an object and taking into account our estimate of its distance, we also obtain much more important information from the degree of *convergence* of the visual axes. We refer the position of an object, viewed with both eyes, to the point where both visual axes intersect. The angle formed by the two visual axes at this point is called the “angle of convergence of the visual axes” (*Gesichtswinkel*). The larger, therefore, the visual angle, the size of the retinal image remaining the same—we judge the object to be nearer. The nearer the object is, it may be the smaller in order to form a “*visual angle*” of the same size, such as a distant large object would give. Hence, we conclude, that with the same apparent size (equally large visual angle, or retinal images of the same size), we judge that object to be smallest, which gives the greatest convergence of the visual axes during binocular vision. As to the muscular exertion necessary for this purpose, we obtain information from the *muscular sense* of the ocular muscles.

Experiments and Proofs—The Chess-board Phenomenon of H. Meyer.—If we look at a uniform chess-board-like pattern (tapestry), then, when the visual axes are directed directly forwards, the spaces on the pattern appear of a certain size. If, now, we look at a nearer object, we may cause the visual axes to cross, when the pattern apparently moves towards the plane of the fixed point, so that the crossed double images are superposed, and the pattern at once appears smaller.

2. Rollett looks at an object through two thick plates of glass placed at an angle. The plates are at one time so placed that the apex of the angle is directed

towards the observer (Fig. 425, II), at another in the reverse position (I). If both eyes, f and i , are to see the object a , in I, then, as the glass plates so displace the rays, a, c , and a, g , as to make them parallel with the direction of these rays, viz., e, f , and h, i , then the eyes must converge more than when they are turned directly towards a . Hence, the object appears nearer and smaller, as at a_1 . In II, the rays, $b_1 k$, and $b_1 o$, from the nearer object, b_1 , fall upon the glass plates. In order to see b_1 , the eyes (n and q), must diverge more, so that b appears more distant and larger.

3. In looking through *Wheatstone's reflecting stereoscope* (Fig. 422, II), it is obvious that the more the two images approach the observer, the more must the observer converge his visual axes, because the angles of incidence and reflexion are greater. Hence, the compound picture now appears to him to be smaller. If the centre of the image, R , recedes to R_1 , then, of course, the angle, S_{11}, r_p , is equal to S_1, rR_1 , and the same on the left side.

4. In using the *telestereoscope*, the two eyes are, as it were, separated from each other, then, of course, in looking at objects at a certain distance, the convergence of the visual axes must be greater than in normal vision. Hence, objects in a landscape appear as in a small model. But as we are accustomed to infer that such small objects are at a great distance, hence the objects themselves appear to recede in the distance.

Estimation of Distance.—When the retinal images are of the same size, we estimate the distance to be greater, the less the *effort of accommodation*, and conversely. In binocular vision, when the retinal images are of the same size, we infer that that object is most distant for which the optic axes are least converged, and conversely. Thus, the estimation of size and distance go hand in hand, in great part at least, and the correct estimation of the distance also gives us a correct estimate of the size of objects (Descartes). A further aid to the estimation of distance is the observation of the *apparent displacement* of objects, on moving our head or body. In the latter, especially, lateral objects appear to change their position toward the back-ground, the nearer they are to us. Hence, when travelling in a train, in which case the change of position of the objects occurs very rapidly, the objects themselves are regarded as nearer (Sick), and also smaller (Dove).

Lastly, those objects appear to us to be *nearest* which are most *distinct* in the field of vision.

Example.—A light in a dark landscape, and a dazzling crown of snow on a hill,

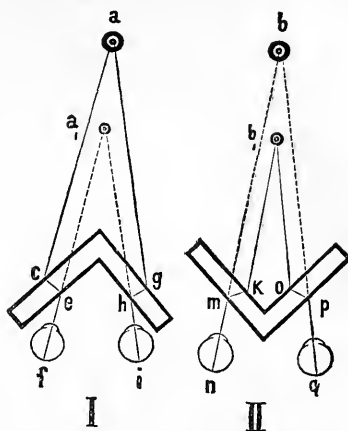

Fig. 425.

Rollett's glass plate apparatus.

appear to be near to us; looked at from the top of a high mountain, the silver glancing curved course of a river not unfrequently appears as if it were raised from the plane.

False Estimates of Size and Direction.—1. A line divided by intermediate points appears longer than one not so divided. Hence, the heavens do not appear to us as a hollow sphere, but as curved like an ellipse; and for the last reason the disc of the setting sun is estimated to be larger than the sun when it is in the zenith (Ptolemy, 150 A.D.). 2. If we move a circle slowly to and fro behind a slit it appears as a horizontal ellipse, if we move it rapidly it appears as a vertical ellipse. 3. If a very fine line be drawn obliquely across a vertical thick black line, then the direction of the fine line beyond the thick one appears to be different from its original direction. 4. **Zöllner's Lines.**—Draw three parallel horizontal lines 1 centimetre apart, and through the upper and lower ones draw short oblique parallel lines in the direction from above and the left, to below and the right; through the middle line draw similar oblique lines, but in the opposite direction, then the three horizontal lines no longer appear to be parallel. If we look in a dark room at a bright vertical line, and then bend the head toward the shoulder, the line appears to be bent in the opposite direction (Aubert).

404. Protective Organs of the Eye.

I. The **eyelids** are represented in section in Fig. 426. The tarsus is in reality not a cartilage, but merely a rigid plate of connective-tissue, in which the Meibomian glands are imbedded; acinous sebaceous glands moisten the edges of the eyelids with fatty matter. At the basal margin of the tarsus, especially of the upper one, close to the reflection of the conjunctiva, there opens the acinotubular glands of Krause. The conjunctiva covers the anterior surface of the bulb as far as the margin of the cornea, over which the epithelium alone is continued. On the posterior surface of the eyelid the conjunctiva is partly provided with papillæ. It is covered by stratified prismatic epithelium. Coiled glands occur in ruminants just outside the margin of the cornea (Meissner), while outside this towards the outer angle of the eye in the pig, there are simple glandular sacs (Manz). Waldeyer describes modified sweat glands in the tarsal margins in man. Small lymphatic sacs in the conjunctiva are called trachoma glands. Krause found *end-bulbs* in the conjunctiva bulbi. The blood-vessels in the conjunctiva communicate with the juice canals in the cornea and sclerotic (pp. 965, 966). The secretion of the conjunctiva, besides some mucus, consists of tears, which may be as abundant as those formed in the lachrymal glands.

The **closure** of the eyelids is accomplished by the orbicularis palpebrarum (*facial nerve*, § 349), whereby the upper lid falls in virtue of its own weight. This muscle contracts—1, voluntarily; 2, involuntarily (single contractions); 3, reflexly by stimulation of all the sensory fibres of the trigeminus distributed to the bulb and its immediate neighbourhood (§ 347), also by intense stimulation of the retina by light; 4, continued involuntary closure occurs during sleep.

The **opening** of the eyelids is brought about by the passive descent of the lower one, and the active elevation of the upper eyelid by the levator palpebræ superioris (§ 345). The smooth muscular fibres of the eyelids also aid (p. 795).

II. The **lachrymal apparatus** consists of the lachrymal glands, which in structure closely resemble the parotid, their acini being lined by low cylindrical granular epithelium. Four to five larger and eight to ten smaller excretory ducts conduct the tears above the outer angle of the lid into the fornix conjunctivæ. The tear ducts, beginning at the puncta lachrymalia, are composed of connective- and elastic-tissue, and are lined by stratified squamous epithelium. Striped muscle accompanies the duct, and by its contraction keeps the duct open (Wedl). Toldt found no sphincter surrounding the puncta lachrymalia, while Gerlach found an incomplete circular musculature. The connective-tissue covering of the tear sac and canal is united with the adjoining periosteum. The thin mucous membrane, which contains much adenoid tissue and lymph cells, is lined by a single layer of ciliated cylindrical epithelium, which below passes into the stratified squamous form. The opening of the duct is often provided with a valve-like fold (Hasner's valve).

The **conduction of the tears** occurs between the lids and the bulb by means of *capillarity*, the closure of the eyelids aiding the process.

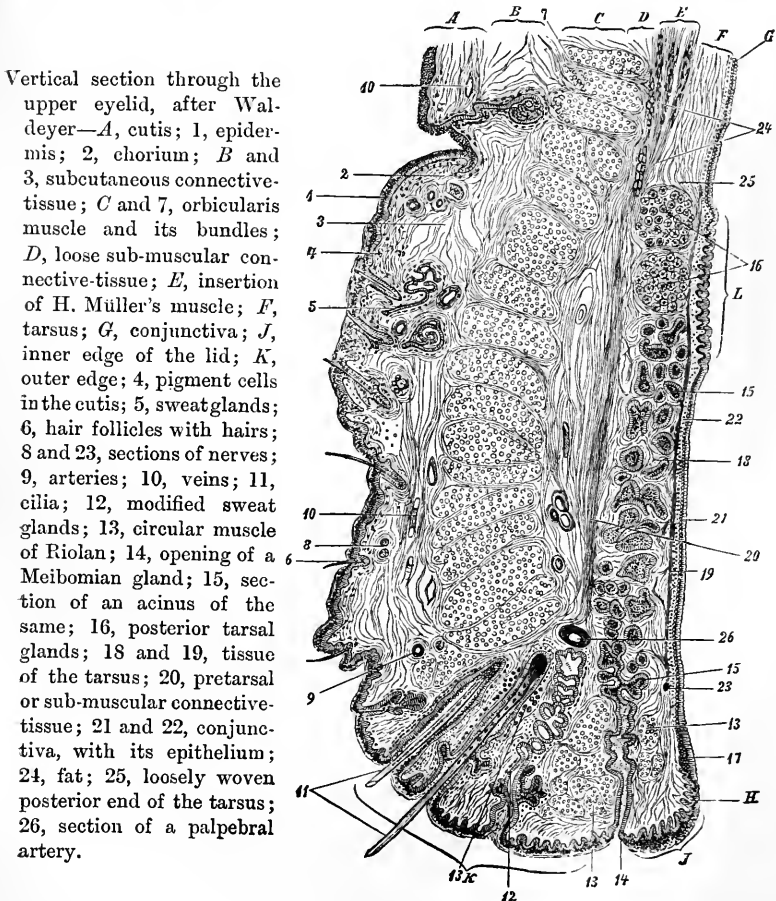

Fig. 426.

The Meibomian secretion prevents the overflow of the tears, [just as greasing the edge of a glass vessel prevents the water in it from overflowing]. The tears are conducted from the puncta through the duct, especially by a siphon action (Ad. Weber). Horner's muscle (also known to Duvernoy, 1678) likewise aids, as every time the eyelids are closed it pulls upon the posterior wall of the sac, and thus dilates the latter, so that it aspirates tears into it (Henke).

E. H. Weber and Hasner ascribe the aspiration of the tears to the diminution of the amount of air in the nasal cavities during inspiration. Arlt asserts that the tear sac is compressed by the contraction of the orbicularis muscle, so that the tears must be forced towards the nose. Lastly, Stellwag supposes that, when the eyelids are closed, the tears are simply pressed into the puncta, while Gad denies that there is any kind of pumping mechanism in the nasal canal. Landois points out that the tear ducts are surrounded by a plexus of veins, which according to their state of distension may influence the size of these tubes.

The secretion of tears occur only by *direct* stimulation of the lachrymal nerve (p. 792); subcutaneous malar (p. 797, 2) and cervical sympathetic (p. 832, 6), which have been called *secretory nerves*. They may also be excited *reflexly* (p. 798) by stimulation of the nasal mucous membrane, only on the same side (Herzenstein). The ordinary secretion in the waking condition is really a reflex secretion produced by the stimulation of the anterior surface of the bulb by the air, or the evaporation of tears. In sleep, all these factors are absent, and there is no secretion. Reichel found that in the *active* gland (after injection of pilocarpin), the secretory cells became granular, turbid, and smaller, while the outlines of the cells became less distinct, and the nuclei spheroidal. In the *resting* gland, the cells are bright and slightly granular with irregular nuclei. Intense stimulation by *light* acting on the optic nerve causes a reflex secretion of tears. The flow of tears accompanying certain violent emotions, and even hearty laughing, is still unexplained. During coughing and vomiting, the secretion of tears is increased partly reflexly, and partly by the outflow being prevented by the expiratory pressure.

Function.—The tears moisten the bulb, protect it from drying, and float away small particles, being aided in this by the closure of the eyelids. Atropin diminishes the tears (Mogaard).

Composition.—The tears are alkaline, saline to taste, and represent a "serous" secretion. Water 98.1 to 99; 1.46 organic substances (0.1 albumin and mucin, 0.1 epithelium); 0.4 to 0.8 salts (especially NaCl).

405. Comparative—Historical.

Comparative.—The simplest form of visual apparatus is represented by aggregations of pigment cells in the outer coverings of the body, which are in connection

with the termination of afferent nerves. The pigment absorbs the rays of light, and in virtue of the light-ether, discharges kinetic energy, which excites the terminations of the nervous apparatus. Collections of pigment cells, with nerve-fibres attached, and provided with a clear refractive body, occur on the margin of the bell of the higher medusæ, while the lower forms have only aggregations of pigment on the bases of their tentacles. Also, in many lower worms, there are pigment spots near the brain. In others, the pigment lies as a covering round the terminations of the nerves, which occur as "crystalline rods" or "crystalline spheres." In parasitic worms the visual apparatus is absent. In **star-fishes** the eyes are at the tips of the arms, and consist of a spherical crystal organ surrounded with pigment, with a nerve going to it. In all other echinodermata there are only accumulations of pigment. Amongst the **annulosa** there are several grades of visual apparatus—1. *Without a cornea*, there may be only one crystal sphere (nervous end-organ) near the brain, as in the young of the crab; or there may be several crystal spheres forming a compound eye, as in the lower crabs. 2. *With a cornea*, consisting of a lenticular body formed from the chitin of the outer integument, the eye itself may be simple, merely consisting of one crystal rod, or it may be compound. The compound eye consists of only one large lenticular cornea, common to all the crystal rods, as in the spiders; or each crystal rod has a special lenticular cornea for itself. The numerous rods surrounded by pigment are closely packed together, and are arranged upon a curved surface, so that their free ends also form a part of a sphere. The chitinous investment of the head is faceted, and forms a small corneal lens on the free end of each rod. According to one view, each facette, with the lens and the crystal sphere, is a special eye, and just as man has two eyes, so insects have several hundred. Each eye sees the picture of the outer world *in toto*. This view is supported by the following experiment of van Leeuwenhoek:—If the cornea be sliced off, each facette thereof gives a special image of an object. If a cross be made on the mirror of a microscope, while a piece of the faceted cornea is placed as an object upon the stage, then we see an image of the cross in each facette of the cornea. Thus, for each rod (crystal sphere) there would be a special image. Each corneal facette, however, forms only a part of the image of the outer world, so that we must regard the image as composed like a mosaic. Amongst **mollusca**, the fixed brachiopoda have two pigment spots near the brain, but only in their larval condition; while the mussel has, under similar conditions, pigment spots, with a refractive body. The adult mussel, however, has pigment spots (ocelli) only in the margin of the mantle, but some molluscs have stalked and highly developed eyes. Some of the lower snails have no eyes, some have pigment spots on the head, while the garden snail has stalked eyes provided with a cornea, an optic nerve with retina and pigment, and even a lens and vitreous body. Amongst **cephalopoda**, the nautilus, has no cornea or lens, so that the sea-water flows freely into the orbits. Others have a lens and no cornea, while some have an opening in the cornea (*Loligo*, *Sepia*, *Octopus*). All the other parts of the eye are well developed. Amongst **vertebrata**, amphioxus has no eyes. They exist in a degenerated condition in *Protelus* and the mammal *Spalax*. In many fishes, amphibians, and reptiles, the eye is covered by a piece of transparent skin. Some hag-fishes, the crocodile, and birds have eyelids, and a *nictitating membrane* at the inner angle of the eye. Connected with it is the *Harderian gland*. In mammals, the nictitating membrane is represented only by the *plica semilunaris*. There is no lachrymal apparatus in fishes. The tears of snakes remain under the watch-glass-like cutis with which the eyes are covered. The sclerotic often contains cartilage which may ossify. A vascular organ, the *processus falciformis*, passes from the middle of the choroid into the interior of the vitreous body in osseous fishes, its anterior extremity being termed the *campanula Halleri*. Similarly, there is the *pecten* in birds, but it is provided with muscular fibres. In birds the cornea is surrounded by a bony ring. The whale has an enormously

thick sclerotic. In aquatic animals the lens is nearly spherical. The muscles of the iris and choroid are transversely striped in birds and reptiles. The retinal rods in all vertebrates are directed from before backwards, while the analogous elements (crystal rods and spheres) in invertebrata are directed from behind forward.

Historical.—The Hippocratic School were acquainted with the optic nerve and lens. Aristotle (384 B.C.) mentions that section of the optic nerve causes blindness—he was acquainted with after images, short and long sight. Herophilus (307 B.C.) discovered the retina, and the ciliary processes received their name in his school. Galen (131-203 A.D.) described the six muscles of the eyeball, the puncta lachrymalia, and tear duct. Berengar (1521) was aware of the fatty matter at the edge of the eyelids. Stephanus (1545) and Casseri (1609) described the Meibomian glands, which were afterwards redescribed by Meibom (1666). Fallopius described the vitreous membrane and the ciliary ligament. Plater (1583) mentions that the posterior surface of the lens is more curved. Aldrovandi observed the remainder of the pupillary membrane (1599). Observations were made at the time of Vesalius (1540) on the refractive action of the lens. Leonardo da Vinci compared the eye to a camera obscura. Maurolykos compared the action of the lens to that of a lens of glass, but it was Kepler (1611) who first showed the true refractive index of the lens and the formation of the retinal image, but he thought that, during accommodation, the retina moved forward and backward. The Jesuit, Scheiner (+1650), mentions, however, that the lens becomes more convex by the ciliary processes, and he assumed the existence of muscular fibres in the uvea. He referred long and short sight to the curvature of the lens, and he first showed the retinal image in an excised eye. With regard to the use of *spectacles* there is a reference in Pliny. It is said that at the beginning of the 14th century the Florentine, Salvino d'Armato degli Armati di Fir (+1317), and the monk, Alessandro de Spina (+1313), invented spectacles. Kepler (1611) and Descartes (1637) described their action. Mayo (+1852) described the 3rd nerve as the constrictor nerve of the pupil. Zinn contributed considerably to our knowledge of the structure of the eye. Ruysch described muscular fibres in the iris, and Monro described the sphincter of the pupil (1794). Jacob described the bacillary layer of the retina—Semmering (1791) the yellow spot. Brewster and Chossat (1819) tested the refractive indices of the optical media. Purkinje (1819) studied subjective vision.

Hearing.

406. Structure of the Organ of Hearing.

Stimulation of the Auditory Nerve.—The normal manner in which the auditory nerve is excited is by means of sonorous vibrations, which set in motion the end organs of the acoustic nerve, which lie in the endolymph of the labyrinth of the inner ear, on membranous expansions of the cochlea and semicircular canals. Hence the sonorous vibrations are first transmitted to the fluid in the labyrinth, and this, in turn, is thrown into waves, which set the end organs into vibration. Thus the excitement of the auditory nerves is brought about by the *mechanical stimulation of the wave-motion of the lymph of the labyrinth.*

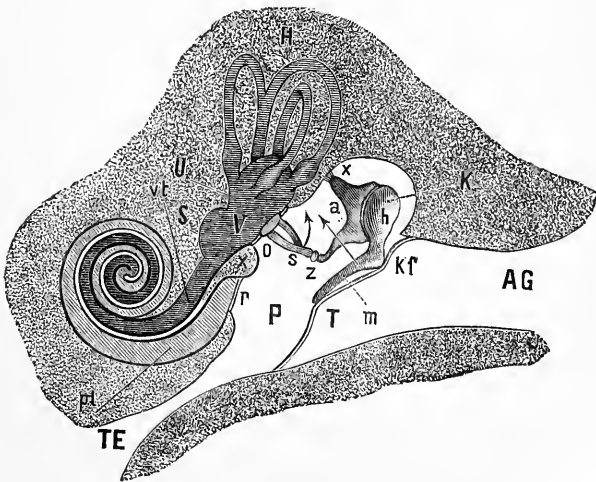

Fig. 427.

Scheme of the organ of hearing—AG, external auditory meatus; T, tympanic membrane; K, malleus with its head (*h*), short process (*kf*), and handle (*m*); *a*, incus with its short process (*x*) and long process—the latter is united to the stapes (*s*) by means of the Sylvian ossicle (*z*); P, middle ear; *o*, fenestra ovalis; *r*, fenestra rotunda; *x*, beginning of the lamina spiralis of the cochlea; *pt*, its scala tympani, and *vt*, its scala vestibuli; V, vestibule; S, saccule; U, utricle; H, semicircular canals; TE, Eustachian tube. The long arrow indicates the line of traction of the tensor tympani; the short curved one, that of the stapedius.

The fluid or lymph of the labyrinth is surrounded by the exceedingly hard osseous mass of the temporal bone (Fig. 427). Only at one small roundish and slightly triangular point (*r*), the *fenestra rotunda*, the fluid is bounded by a delicate, yielding membrane, which is in contact with the air in the middle ear or tympanum (P). Not far from the *fenestra rotunda* is the *fenestra ovalis* (*o*), in which the base of the stapes (*s*) is fixed by means of a yielding membranous ring. The outer surface of this also is in contact with the air in the middle ear. As the perilymph of the inner ear is in contact at these two places with a yielding boundary, it is clear that the lymph itself may exhibit oscillatory movements, as it must follow the movements of the yielding boundaries.

The sonorous vibrations may set the perilymph in vibration in *three* different ways:—

1. **Conduction through the Bones of the Head.**—This occurs especially only when the vibrating solid body is applied directly to some part of the head, *e.g.*, a tuning-fork placed on the head, the sound being propagated most intensely in the direction of the prolongation of the handle of the instrument—also when the sound is conducted to the head by means of fluid, as when the head is ducked under water. Vibrations of the air, however, are practically not transferred directly to the bones of the head, as is shown by the fact that we are deaf when the ears are stopped.

The soft parts of the head which lie immediately upon bone conduct sound best, and, of the projecting parts, the best conductor is the cartilaginous part of the external ear. But even under the most favourable circumstances, conduction through the bones of the head is far less effective than the conduction of the sound-waves through the external auditory meatus. If a tuning-fork be made to vibrate between the teeth until we no longer hear it, its tone may still be heard on bringing it near the ear (Rinne). The conduction through the bones is favoured when the oscillations are not transferred from the bones to the tympanic membrane, and are thus transferred to the air in the outer ear. Hence, we hear the sound of a tuning-fork applied to the head better when the ears are stopped, as this prevents the propagation of the sound-waves through the air in the outer ear. If, in a *deaf* person, the conduction is still normal through the cranial bones, then the cause of the deafness is not in the nervous part of the ear, but in the external sound-conducting part of the apparatus.

2. **Normal hearing takes place through the *external auditory meatus*.** The enormous vibrations of the air first set the tympanic membrane (Fig. 427, T) in vibration, this moves the malleus (*h*), whose long process is inserted into it; the malleus moves the incus (*a*), and this the stapes (*s*), which transfers the movements of its plate to the perilymph of the labyrinth.

3. **Direct Conduction to the Fenestra.**—In man, in consequence of occasional disease of the middle ear, whereby the tympanic membrane and auditory

ossicles may be destroyed, the auditory apparatus may be excited, although only in a very feeble manner, by the vibrations of the air being directly transferred to the membrane of the fenestra rotunda (*r*), and the parts closing the fenestra ovalis (*o*). The membrane of the fenestra rotunda may vibrate alone, even when the oval window is rigidly closed (Weber-Liel).

407. Physical Introduction.

Sound.—Sound is produced by the vibration of elastic bodies capable of vibration. Alternate condensation and rarefaction of the surrounding air are thus produced; or, in other words, sound-waves in which the particles vibrate longitudinally or in the direction of the propagation of the sound are excited. Around the point of origin of the sound, these condensations and rarefactions occur in equal concentric circles, which conduct the sound vibrations to our outer ear. The vibrations of the sounding body are so called “stationary vibrations” (E. H. and W. Weber)—*i.e.*, all the particles of the vibrating body are always in the same phase of movement, in that they pass into movement simultaneously, they reach the maximum of movement simultaneously—*e.g.*, in the particles of a sounding, vibrating metal rod. Sound is *produced* by the stationary vibrations of elastic bodies; it is *propagated* by progressive wave-motion of elastic media, generally the air. The wave-length of a tone—*i.e.*, the distance of one maximum of condensation to the next one in the air, is proportional to the duration of the vibration of the body, whose vibrations produce the sound-waves.

If λ is the wave-length of a tone, t in seconds the duration of a vibration of the body producing the wave, then $\lambda = n t$, where $n = 340.88$ metres, which is the rate per second of propagation of sound-waves in the air. The rapidity of the transmission of sound-waves in water = 1435 metres per second—*i.e.*, nearly four times as rapid as in air; while in solids capable of vibration, it is propagated from seven to eighteen times faster than in the air. Sound-waves are conducted best through the same medium; when they have to pass through several media they are always weakened.

Reflection of the sound-waves occurs when they impinge upon a solid obstacle, in which case the angle of reflection is always equal to the angle of incidence.

Wave Movements.—We distinguish I. **Progressive wave movements** which occur in two forms—1. As *longitudinal waves* (Chladni), in which the individual particles of the vibrating body vibrate around their centre of gravity in the direction of the propagation of the wave; examples are the waves in water and air. This movement causes an accumulation of the particles at certain places—*e.g.*, on the crests of the waves in water-waves, while at other places they are diminished. This kind of wave is called a *wave of condensation and rarefaction*. 2. If, however, each particle in the progressive wave moves *vertically* up and down—*i.e.*, transversely to the direction of the propagation of the wave, then we have the simple *transverse waves* (Chladni), or progressive waves, in which there is no condensation or rarefaction in the direction of propagation, as each particle is merely displaced laterally. An example of this is the *progressive waves in a rope*.

II. **Stationary Flexion Waves.**—When all the particles of an elastic vibrating body so oscillate that all of them are always in the same phase of movement as the limbs of a vibrating tuning-fork or a plucked string, then this kind of movement is described as stationary flexion waves. As bodies, whose expansion in the direction of oscillation is very slight, vibrate to and fro in the stationary flexion wave, so we see that the small parts of the auditory apparatus (tympanic membrane, ossicles, lymph of the labyrinth) oscillate in stationary flexion waves.

408. Ear Muscles—External Auditory Meatus.

External Ear.—When the external ear is absent, little or no impairment of the hearing is observed; hence, the physiological functions of these organs are but

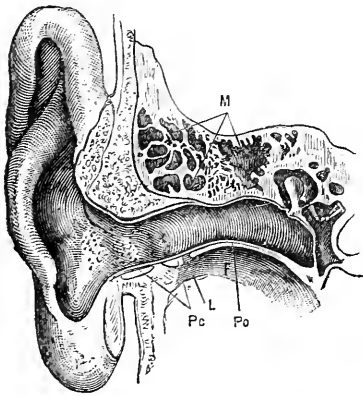

Fig. 428.

The external auditory meatus and the tympanic cavity—M, osseous spaces in the temporal bone; Pc, cartilaginous part of the meatus; L, membranous union between both; F, articular surface for the condyle of the lower jaw (after Urbantschitsch).

and minor are regarded as elevators of the helix, the transversus and obliquus auriculæ as dilators of the concha; the tragicus and antitragicus as constrictors of the meatus. In animals, the external ear and the action of its muscles have a marked effect upon hearing. The muscles point the ear in the direction of the sound, while other muscles contract or dilate the space within the external ear. In many diving animals, the meatus can be closed by a kind of valve.

The external meatus is 3 to 3.25 cm. long [$1\frac{1}{8}$ – $1\frac{1}{4}$ inch], 8 to 9 mm. high, and 6 to 8 mm. broad at its outer opening. It is the conductor of the sound-waves to the tympanic membrane, so that almost all the sound-waves first impinge upon its wall, and are then reflected towards the tympanic membrane. To see well down into the meatus, we must pull the auricle upwards and backwards. Occlusion of the meatus, especially by a plug of inspissated wax (p. 604) of course interferes with the hearing.

409. Tympanic Membrane.

The tympanic membrane (Fig. 430), which is tolerably laxly fixed in a special osseous cleft, with a thickened margin, is an elastic,

slight. Boerhaave thought that the elevations and depressions of the outer ear might be connected with the reflection of the sound-waves. Numerous sound-waves, however, must be again reflected outwards; and those waves which reach the deep part of the concha, are said to be reflected towards the tragus, to be reflected by it into the external auditory meatus. According to Schneider, when the depressions in the ear are filled up with wax, hearing is impaired. Mach points out that the dimensions of the external ear are proportionally too small to act as reflecting organs for the wave-lengths of noises.

Muscles of the External Ear.—1. The whole ear is moved by the retrahentes, attrahens, and attollens. 2. The form of the ear may be altered by the tragicus, antitragicus, helicis major and minor internally; and by the transversus and obliquus auriculæ externally. Persons who can move their ears do not find that the hearing is influenced during the movement. The Mm. helicis major

unyielding, and almost non-extensible membrane, of about 0.1 mm. in thickness, and with a superficial area of 50 square millimetres. It is elliptical in form, its greatest diameter being 9.5 to 10 mm., and its lesser 8 mm., and it is fixed in the floor of the external meatus obliquely, at an angle of 40° , being directed from above and outwards, downwards and inwards. Both tympanic membranes converge anteriorly, so that if both were prolonged, they would meet to form an angle of 130° to 135° . The oblique position enables a larger surface to be presented than would be obtained if it were stretched vertically, so that more sound-waves can fall vertically upon it. The membrane is not stretched flat, but a little under its centre (umbilicus), it is drawn slightly inwards by the handle of the malleus, which is attached to it; while the short process of the malleus slightly bulges out the membrane near its upper margin (Figs. 427 and 435).

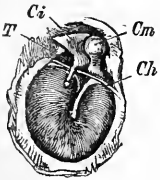

Fig. 429.

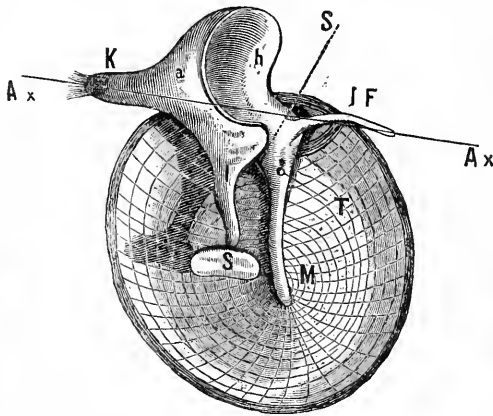

Fig. 430.

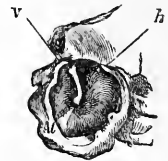

Fig. 431.

Fig. 429.—Tympanic membrane with the auditory ossicles (left) seen from within—*Ci*, incus; *Cm*, malleus; *Ch*, chorda tympani; *T*, pouch-like depression (after Urbantschitsch).

Fig. 430.—Tympanic membrane and the auditory ossicles (left) seen from within, *i.e.*, from the tympanic cavity—*M*, manubrium or handle of the malleus; *T*, insertion of the tensor tympani; *h*, head; *lF*, long process of the malleus; *a*, incus, with the short (*K*) and the long (*l*) process; *S*, plate of the stapes; *Ax*, *Ax*, is the common axis of rotation of the auditory ossicles; *S*, the pinion-wheel arrangement between the malleus and incus.

Fig. 431.—Tympanic membrane of a new-born child seen from without, with the handle of the malleus visible on it—*At*, tympanic ring with its anterior (*v*) and posterior (*h*) ends.

Structure.—The tympanic membrane consists of *three* layers:—1. The membrana propria is a fibrous membrane with radial fibres on its outer surface, and circularly arranged fibres on its inner aspect. 2. The surface directed towards the meatus is covered with a thin and semi-transparent part of the cutis. 3. The

side towards the tympanum is covered with a delicate mucous membrane, with simple squamous epithelium. Numerous nerves and lymph-vessels, as well as inner and outer blood-vessels, occur in the membrane.

[The middle layer, or substantia propria, is fixed to a ring of bone, which is deficient above. It is filled up by a layer composed of the mucous and cutaneous layers called the *membrana flaccida*, or Shrapnell's membrane.]

[**Examination.**—When examining the outer ear and membrana tympani pull the auricle upwards and backwards. The membrana tympani is examined by means of an ear speculum (Fig. 432). The speculum is placed in the ear, and light is reflected into it by means of a concave mirror, perforated in the centre, and having a focal distance of four or five inches. It is convenient to have the mirror fixed to a band placed round the head, as in the case of the laryngoscopic reflector (Fig. 269). It is important to remember that the membrane is placed obliquely, so that the posterior and upper parts are nearer the surface. The membrane in health is greyish in colour and transparent, so that the handle of the malleus is seen running from above downwards and backwards, while at the anterior and inferior part there is a cone of light, with its apex directed inwards.]

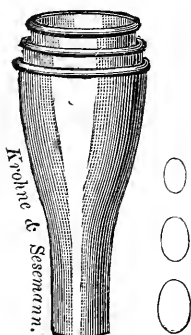

Fig. 432.

Ear specula of various sizes.

Function.—The tympanic membrane catches up the sound-waves which penetrate into the external meatus, and is set into vibration by them, the vibrations corresponding in number and amplitude to the vibrating movements of the air. Politzer connected the auditory ossicles fixed to the tympanic membrane of a duck with a recording apparatus, and could thus register the vibrations produced by sounding any particular tone. Owing to its small dimensions, the tympanic membrane can vibrate *in toto*, to and fro in the direction of the sound-waves corresponding to the condensations and rarefactions of the vibrating air, and, therefore, executes *transverse vibrations*, for which it is specially adapted, owing to the relatively slight resistance.

Fundamental Note.—Stretched strings and membranes are generally only thrown into actual and considerable sympathetic vibration when they are affected by tones which correspond with their own fundamental tone, or whose number of vibrations is some multiple of the number of vibrations of the same, as the octave. When other tones act on them they exhibit only inconsiderable sympathetic vibration. If a membrane be stretched over a funnel or cylinder, and if a nodule of sealing wax attached to a silk thread be made just to touch the centre of the membrane, then the sealing wax remains nearly at rest when tones or sounds are made in the neighbourhood; as soon, however, as the fundamental or proper tone of this arrangement is sounded, the nodule is propelled by the strong vibrations of the membrane.

If we apply this to the tympanic membrane, then it also should exhibit very great vibrations when its own fundamental note is sounded, but only slight vibrations when other tones are produced. This, however, would produce great inequality in the audible sounds. There is an arrangement of the membrane whereby this is prevented. 1. Great resistance is offered to the vibrations of the tympanic membrane, owing to its union with the auditory ossicles. These act as a *damping apparatus*, which provides, as in damped membranes generally, that the tympanic membrane shall not exhibit excessive sympathetic vibrations for its own fundamental note. But the damping also makes the sympathetic vibrations less for all the other tones. In this way, *all* vibrations of the tympanic membrane are modified; especially, however, is the excessive vibration diminished during the sounding of its fundamental tone. The membrane is at the same time rendered more capable of responding to the vibrations of different wave-lengths. The damping also *prevents after-vibrations*. 2. Corresponding to the small *mass* of the tympanic membrane, its sympathetic vibrations must also be small. Nevertheless, these slight elongations are quite sufficient to convey the sonorous movements to the most delicate end-organs of the auditory nerve; in fact, there are arrangements in the tympanum which still further diminish the vibrations of the tympanic membrane.

As v. Helmholtz has shown, the strong sympathetic vibrations of the tympanic membrane are not completely set aside by this damping arrangement. The painful sensations produced by some tones are, perhaps, due to the sympathetic vibration of the membrana tympani. According to Kessel, certain parts of the membrane vibrate to certain tones.

Pathological.—Thickenings or inequalities of the tympanic membrane interfere with the acuteness of hearing, owing to the diminished capacity for vibration thereby produced. Holes in and loss of its substance act similarly. In extensive destruction, an artificial tympanum is placed in the external meatus, and its vibrations, to a certain extent, replace those of the lost membrane (Toynbee).

[Fig. 433 shows the artificial tympanic membrane of Toynbee.]



Fig. 433.
Toynbee's artificial
membrana
tympani.

410. The Auditory Ossicles and their Muscles.

Function.—The auditory ossicles have a double function—1. By means of the “chain” which they form, they transfer the vibrations of the tympanic membrane to the perilymph of the labyrinth. 2. They also afford points of attachment for the muscles of the middle ear, which can alter the *tension* of the membrana tympani and the *pressure* of the labyrinth.

Mechanism.—The *form* and *position* of the ossicles are given in

figures 434 and 435. They form a jointed *chain* which connects the tympanic membrane, *M*, by means of the malleus, *h*, incus, *a*, and stapes, *S*, with the perilymph of the labyrinth. The *mode of movement* of the ossicles is of special importance. The handle of the malleus (Fig. 435, *n*) is firmly united to the fibres of the tympanic membrane. Besides this, the malleus is fixed by *ligaments* which prescribe the direction of its movements. Two ligaments—the lig. mallei anticum (passing from the

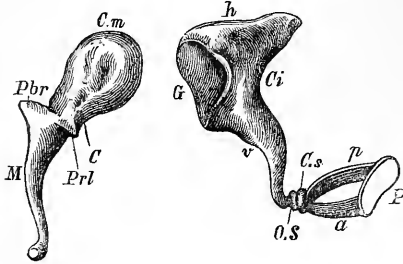

Fig. 434.

The auditory ossicles (right)—*C.m*, head; *C*, neck; *Pbr*, short process; *PrL*, long process; *M*, handle of the malleus; *Ci*, body; *G*, articular surface; *h*, short, and *v*, long process of the incus; *O.S*, so-called lenticular ossicle; *C.s*, head; *a*, anterior, and *p*, posterior limb; *P*, plate of the stapes.

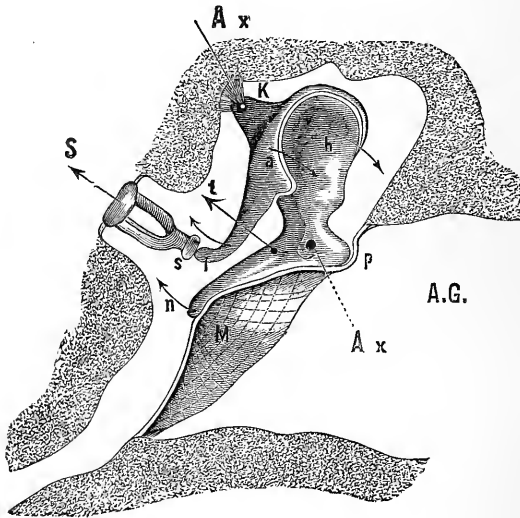

Fig. 435.

Tympanum and auditory ossicles (left) magnified—*A.G.*, external meatus; *M*, membrana tympani, which is attached to the handle of the malleus, *n*, and near it the short process, *p*; *h*, head of the malleus; *a*, incus; *k*, its short process with its ligament; *l*, long process; *s*, Sylvian ossicle; *S*, stapes; *A x*, *A x*, is the axis of rotation of the ossicles—it is shown in perspective, and must be imagined to penetrate the plane of the paper; *t*, line of traction of the tensor tympani. The other arrows indicate the movement of the ossicles when the tensor contracts.

processus Folianus), and the posticum (from a small crest on the neck)—together form a common axial band (v. Helmholtz), which acts in the direction from behind forwards—*i.e.*, parallel to the surface of the tympanic membrane. The neck of the malleus lies between the insertions of both ligaments. The united ligament determines the “*axis of rotation*” of the movement of the malleus.

When the handle of the malleus is drawn *inwards*, of course its head moves in the opposite direction, or *outwards*. The *incus*, *a*, is only partially fixed by a ligament, which attaches its short process to the wall of the tympanic cavity, in front of the entrance to the mastoid cells, *k*. The not very tense articulation joining it to the head of the malleus, *h*, which lies with its saddle-shaped articular surface in the hollow of the incus, is important. The lower margin of the incus (Fig. 434, S) acts like a tooth of a cog-wheel. Thus, when the handle of the malleus moves *inwards* to the tympanic cavity, the incus, and its long process, *b*, which is parallel to the handle of the malleus, also pass *inwards*. The incus forms almost a right angle with the stapes, S, through the intervention of the Sylvian ossicle, *s*. If, however, as by condensation of the air in the tympanum, the *membrana tympani* and the handle of the malleus move *outwards*, the long process of the incus does not make a similar movement, as the malleus moves away from this margin of the incus. Hence, the stapes is not liable to be torn from its socket. The malleus and incus form an angular lever, which moves round a common axis (Fig. 430 and Fig. 435, A *x*, A *x*). In the *inward* movement, the malleus follows the incus, as if both formed one piece. The *common axis* (Fig. 430) is not, however, the axial ligament of the malleus, but it is formed *anteriorly* by the processus Folianus, *l F*, directed forwards, and *posteriorly* by the short process of the incus directed backwards. The rotation of both ossicles around this axis occurs in a plane, vertical to the plane of the *membrana tympani*. During the rotation, of course the parts above this axis (head of the malleus and upper part of the body of the incus) take a direction opposite to the parts lying below it (the handle of the malleus and the long process of the incus), as is indicated in Fig. 435 by the direction of the arrows. The movement of the handle of the malleus must follow that of the *membrana tympani*, and *vice versa*, while the movement of the stapes is connected with the movement of the long process of the incus. As the long process of the incus is only two-thirds of the length of the handle of the malleus (Figs. 427, 430, 435), of course the *excursion* of the tip of the former, and with it of the stapes, must be correspondingly *less* than the movement of the tip of the handle of the malleus; while, on the other hand, the *force* of the movement of

the tip of the handle of the malleus, corresponding to the diminution of the excursion, will be *increased*.

Mode of Vibration.—Thus, the movement of the membrana tympani inwards causes a less extensive but a *more powerful* movement of the foot of the stapes against the perilymph of the labyrinth. V. Helmholtz and Politzer calculated the extent of the movement to be 0.07 mm.

The mode in which the vibrations of the membrana tympani are conveyed to the lymph of the labyrinth, through the chain of ossicles, is quite analogous to the mechanism of these parts, already described. Long delicate glass threads have been fixed to these ossicles, and their movements were thus graphically recorded on a smoked surface (Politzer, Hensen). Or strongly refractive particles are fixed to the ossicles, while the beam of light reflected from them can be examined by means of a microscope (Buck, v. Helmholtz, Mach, and Kessel). All the experiments showed, that the transference of the sound-waves is accomplished by means of the mechanism of the *angular lever*, composed of the auditory ossicles already described. As the vibrations of the membrana tympani are conveyed to the handle of the malleus, they are weakened to about one-fourth of their original strength (Politzer, Buck).

[The membrana tympani is many times (30) larger than the fenestra ovalis, and the relation in size might be represented by a funnel. The arm of the malleal end of the lever, where the power acts is $9\frac{1}{2}$ mm. long, while the short or stapelial arm is $6\frac{1}{2}$ mm., so that the latter moves less than the former, but what is lost in extent is gained in force.]

[Methods.]—Politzer attached small, very light levers to each of the ossicles, and inscribed their movements on a revolving cylinder. An organ-pipe was sounded, and when the levers were of the same length, the malleus made the greatest excursion and the stapes the least. Buck attached starch grains to the ossicles, illuminated them, and observed the movements of the refractive starch granules by means of a microscope provided with a micrometer.]

[The ossicles move *en masse*, and not in the way of propagating molecular vibrations.] As the excursions of the ossicles during sonorous vibrations are, however, only nominal, there is practically no change in the position of the joints with each vibration. The latter will only occur when extensive movements take place by means of the muscles.

The muscles of the auditory ossicles alter the position and tension of the membrana tympani, as well as the pressure of the lymph of the labyrinth. The **tensor tympani**, which lies in an osseous groove above

the Eustachian tube, has its tendon deflected round an osseous projection [processus cochleariformis], which lies external to it, almost at right angles to the groove above it, and is inserted immediately above the axes of rotation of the malleus (Fig 436, M). When the muscle contracts in the direction of the arrow, *t* (Fig. 435), then the handle of the malleus (*n*) pulls the membrana tympani (M) inwards and tightens it. This also causes a movement of the incus and stapes (S), which must be pressed more deeply into the fenestra ovalis, as already described. When the muscle relaxes, then, owing to the *elasticity* of the rotated axial ligament and the tense membrana tympani itself, the position of equilibrium is again restored. The *motor nerve* of this muscle arises from the trigeminus, and passes through the *otic ganglion* (p. 801). C. Ludwig and Politzer observed that stimulation of the fifth nerve within the cranium [dog] caused the above-mentioned movement.



Fig. 436.

Tensor tympani—the Eustachian tube (left).

Use of the Tension.—The tension of the membrana tympani caused by the tensor tympani has a double function (Joh. Müller)—1. The tense membrane offers very great resistance to sympathetic vibrations, when the sound-waves are very intense, as it is a physical fact (Savart), that stretched membranes are more difficult to throw into sympathetic vibration the tenser they are. Thus, the tension so far protects the auditory organ, as it prevents too intense vibrations applied to the membrana tympani from reaching the terminations of the nerves. 2. The tension of the membrana tympani must vary according to the degree of contraction of the tensor. Hereby the membrana for the time being has a different fundamental tone, and is thus capable of vibrating to the correspondingly higher tone, it, as it were, being in a certain sense accommodated.

Comparison with Iris.—The membrana tympani has been compared with the iris. Both membranes prevent by contraction—narrowing of the pupil and tension of the membrana tympani—the too intense action of the specific stimulus from causing too great stimulation, and both *adapt* the sensory apparatus for the action of moderate or weak stimuli. This movement in both membranes is brought about *reflexly*, in the ear through the N. acusticus, which causes a reflex stimulation of the motor fibres for the tensor tympani.

Effect of Tension.—That increased tension of the membrana tympani renders it less sensitive to sound-waves is easily proved, thus:—Close the mouth and nose, and make either a forced expiration, so that the air is forced into the Eustachian tube,

which bulges out the membrana tympani, or inspire forcibly, whereby the air in the tympanum is diminished, so that the membrana bulges inwards. In both cases, hearing is interfered with as long as the increased tension lasts. If a funnel with a small lateral opening, and whose wide end is covered by a membrane, be placed in the external meatus, hearing becomes less distinct when the membrane is stretched (Joh. Müller).

Normally, the tensor tympani is excited *reflexly*. The muscle is not directly and by itself subject to the control of the will. According to L. Fick, the following phenomenon is due to an "associated movement" of the tensor:—When he pressed his jaws firmly against each other he heard in his ear a piping, singing tone, while a capillary tube, which was fixed air-tight into the meatus, had a drop of water which was in it rapidly drawn inwards. During this experiment, a person with normal hearing hears all musical tones as if they were louder, while all the highest non-musical tones are enfeebled (Lucae). When yawning, v. Helmholtz and Politzer found that hearing was enfeebled for certain tones.

Contraction of the Tensor.—Hensen showed that the contraction of the tensor tympani during hearing is not a continued contraction, but what might be termed a "twitch." A twitch takes place at the beginning of the act of hearing, which favours the perception of the sound, as the membrana tympani thus set in motion vibrates more readily to higher tones than when it is at rest. On exposing the tympanum in cats and dogs, it was found that this contraction or twitch occurs only at the beginning of the sound, and that it soon ceases, although the sound may continue.

Action of the Stapedius.—This muscle arises within the eminentia pyramidalis, and is inserted into the head of the stapes and Sylvian ossicle (Fig. 437); when it draws upon the head of the stapes, as indicated in Fig. 427, by the small curved arrow, it must place the bone obliquely, whereby the posterior end of the plate of the stapes is pressed somewhat deeper *inwards* into the fenestra ovalis, while the anterior is, as it were, displaced somewhat *outwards*. The stapes is thereby more fixed, as the fibrous mass [annular ligament], which surrounds the fenestra ovalis and keeps the stapes in its place, becomes more tense. The activity of this muscle, therefore, prevents too intense shocks, which may be communicated from the incus to the stapes, from being conveyed to the perilymph (§ 808, 5). It is supplied by the *facial nerve* (§ 349, 3).



Fig. 437.
Right stapedius
muscle.

The stapedius in many persons executes an *associated* movement, when the eyelids are forcibly closed (§ 349). Some persons can cause it to contract *reflexly* by scratching the skin in front of the meatus, or by gently stroking the outer margin of the orbit (Henle).

Other Views.—According to Lucae, when the stapes is displaced obliquely, its head forces the long process of the incus, and also the membrana tympani, *outwards*, so that it is regarded as an *antagonist* of the tensor tympani. Politzer

observed that the pressure within the labyrinth fell when he stimulated the muscle. According to Toynbee, the stapedius acts as a lever and moves the stapes slightly out of the fenestra ovalis, thus making it more free to move, so that it is more capable of vibrating. Henle supposes that the stapedius is more concerned in *fixing* than in moving the stapes, and that it comes into action when there is danger of too great movement being communicated to the stapes from the incus. Landois agrees with this opinion, and compares the stapedius with the orbicularis palpebrarum, both being protective muscles.

Pathological.—Immobility of the auditory ossicles, either by adhesions or anchyloses, causing diminished vibrations, interferes with hearing; while the same result occurs when the stapes is firmly anchylosed into the fenestra ovalis. The tendon of the tensor tympani has been divided in cases of contracture of the muscle. For paralysis of the tensor see p. 802, and for the stapedius p. 808, 5.

411. Eustachian Tube—Tympanum.

The Eustachian tube [4 centimetres in length, $1\frac{5}{8}$ in.] is the *ventilating tube* of the tympanic cavity. It keeps the tension of the air within the tympanum the same as that within the pharynx and outer air (Fig. 427, 436). Only when the tension of the air is the same outside and inside the tympanum is the normal vibration of the membrana tympani possible. The tube is generally *closed*, as the surfaces of the mucous membrane lining it come into apposition. During *swallowing*, however, the tube is opened, owing to the traction of the fibres of the tensor veli palatini [spheno-salpingo-staphylinus sive abductor tubae (v. Tröltsch), sive dilator tubae (Rüdinger)] inserted into the membrano-cartilaginous part of the tube (Toynbee, Politzer, Moos). (Compare p. 276, 2.) When the tube is closed, the vibrations of the membrana tympani are transferred in a more undiminished condition to the auditory ossicles than when it is open, whereby part of the vibrating air is forced through the tube (Mach and Kessel). If, however, the tympanic cavity is closed *permanently*, the air within it becomes so rarefied (p. 276) that the membrana tympani, owing to the abnormally low tension, becomes drawn inwards, thus causing difficulty of hearing. As the tube is lined by ciliated epithelium (p. 614), it carries outwards to the pharynx the secretions of the tympanum.

Noise in the Tube.—A sharp, hissing noise is heard in the tube during swallowing, when we swallow slowly and at the same time contract the tensor tympani, due to the separation of the adhesive surfaces of its living membrane. Another person may hear this noise by using a stethoscope or his ear.

In **Valsalva's experiment** (p. 112), as soon as the pressure of the air reaches 10–40 mm. Hg. air enters the tube. The sound is heard first, and then we feel the increased tension of the tympanic membrane, owing to the entrance of air into the tympanum. During forced inspiration, when the nose and mouth are closed, air is sucked out, while the tympanum is ultimately drawn inwards.

The M. levator veli palatini, as it passes under the base of the opening of the tube into the pharynx, forms the *levator-eminence* or cushion (Fig. 274, W). Hence, when this muscle contracts and its belly thickens, as at the commence-

ment of the act of deglutition, and during phonation, the lower wall of the pharyngeal opening is raised, and the opening thereby narrowed (Lucae). The *contraction* of the tensor, occurring during the later part of the act of deglutition, dilates the tube.

Other Views.—According to Rüdinger, the tube is always open, although only by a very narrow passage in the upper part of the canal, while the canal is dilated during swallowing. According to Cleland, the tube is generally open, and is closed during swallowing.

[**Practical Importance.**—The tympanic cavity forms an osseous box and, therefore, a protective organ for the auditory ossicles and their muscles, while the increased air space, obtained by its communication with the mastoid cells, permits free vibration of the membrana tympani. The six sides of the tympanum have important practical relations. It is about half an inch in height, and one to two lines in breadth, *i.e.*, from without inwards. Its *roof* is separated from the cavity of the brain by a very thin piece of bone, which is sometimes defective, so that encephalitis may follow an abscess of the middle ear. The *outer* wall is formed by the membrana tympani, while on the *inner* wall are the fenestra ovalis and rotunda, the ridge of the aqueductus Fallopii, the promontory, and the pyramid. The *floor* consists of a thin plate of bone which roofs in the jugular fossa and separates it from the jugular vein. Fractures of the base of the skull may rupture the carotid artery or internal jugular vein; hence, hæmorrhage from the ears is a bad symptom in these cases. Caries of the ear may extend to other organs. The *anterior* wall is in close relation with the carotid artery, while the *posterior* communicates with the mastoid cells, so that fluids from the middle ear sometimes escape through the mastoid cells.]

That the air in the tympanum can communicate its vibrations to the membrane of the fenestra rotunda (p. 1044) is true, but *normally*, this is so slight when compared with the conduction through the auditory ossicles, that it scarcely need be taken into account.

Structure.—The tube and tympanum are lined by a common mucous membrane, covered by ciliated epithelium, while the membrana is lined by a layer of squamous epithelium. Mucous glands were found by Tröltzsch and Wendt in the mucous membrane. [The epithelium covering the ossicles and tensor tympani is not ciliated.]

Pathological.—The tube is often occluded, owing to chronic catarrh and narrowing from cicatrices, hypertrophy of the mucous membrane, or the presence of tumours. The deafness thereby produced may often be cured by *catheterising* the tube from the nose. Effusions into or suppuration within the tympanum of course paralyse the sound-conducting mechanism, while inflammation often causes subsequent affections of the plexus tympanicus. If the temporal bone be destroyed by progressive caries within the tympanum, inflammation of the neighbouring cerebral structures may occur and cause death. (Compare § 346, p. 800—*Otic ganglion.*)

[**Methods.**—Not unfrequently the aurist is called upon to dilate the Eustachian tube, which in certain cases requires the use of a Eustachian catheter introduced into the tube along the floor of the nose (Fig. 438). At other times he requires to

fill the tympanic cavity with air, which is easily done by means of a Politzer's bag (Fig. 439). The nozzle is introduced into one nostril, while the other nostril is



Fig. 438.

Eustachian catheter.

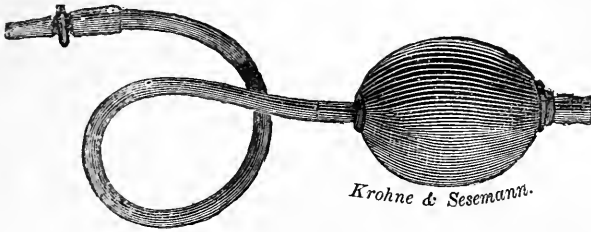

Fig. 439.

Poltzer's ear bag.

closed, and the patient is directed to swallow, while at the same moment the surgeon compresses the bag, and the patient's mouth being closed, air is forced through the open Eustachian tube into the middle ear. Sometimes a small curved narrow manometer, containing a drop of coloured water, is placed in the outer ear (Poltzer). Normally when the patient swallows, the fluid ought to move in the tube.]

412. Conduction of Sound in the Labyrinth.

The vibrations of the foot of the stapes in the fenestra ovalis give rise to waves in the perilymph within the inner ear or labyrinth. These waves are so-called "*flexion waves*," *i.e.*, the perilymph moves in mass before the impulse of the base of the stapes. This is only possible from the existence of a *yielding membrane*—that filling the fenestra rotunda, and sometimes called the *membrana secundaria*, which during rest bulges inwards into the scala tympani, and can be bulged outwards towards the tympanic cavity by the impulse communicated to it by the movement of the perilymph (Fig. 427, *r*). The flexion waves must correspond in number and intensity to the vibrations of the auditory ossicles, and must also excite the free terminations of the auditory nerve, which float free in the endolymph.



Fig. 440.

External appearance of the labyrinth, showing the fenestra ovalis, the cochlea to the left, and (*f*) the upper, (*h*) the horizontal, and (*s*) the posterior semicircular canal (left).

As the endolymph of the saccule and utricle lying in the vestibule

receive the first impulse, and as they communicate anteriorly with the cochlea, and posteriorly with the semicircular canals, consequently the motion of the perilymph must be propagated through these canals. To reach the *cochlea*, the movement passes from the *sacculæ* (lying in the fovea hemispherica) along the *scala vestibuli* to the *helicotrema*, where it passes into the *scala tympani*, where it reaches the membrane of the *fenestra rotunda*, and causes it to bulge outwards. From the *utricle* (lying in the fovea hemielliptica), in a similar manner the movement is propagated through the *semicircular canals*. Politzer observed that the endolymph in the superior semicircular canal rose when he caused contraction of the tensor tympani by stimulating the trigeminus, just as the base of the stapes must be forced against the perilymph with every vibration of the *membrana tympani*.

[From a practical point of view it is well to view the organ of hearing as consisting of two mechanisms :—

1. The sound-conducting apparatus ;
2. The sound-perceiving apparatus.

The former includes the *outer* ear, with its auricle and external meatus ; the *middle* ear and the parts which bound it, or open into it. The latter consists of the *inner* ear with the expansion of the auditory nerve in the labyrinth, the nerve itself, and the sound-perceiving and interpreting centre or centres in the brain (p. 922).]

[Testing the Sound-conduction.—In any case of deafness it is essential to estimate the degree of deafness by the methods stated at p. 1044, and it is well to do so both for such sounds as those of a watch and conversation. We have next to determine whether the *sound-conducting* or the *sound-perceiving* apparatus is affected. If a person is deaf to sounds transmitted through the air, on applying a sounding tuning-fork to the middle line of the head or teeth, and if it be heard distinctly, then the sound-perceiving apparatus is intact, and we have to look for the cause of deafness in the outer or middle ear. In a healthy person, the sound of the tuning-fork is heard of equal intensity in both ears. In this case the sound is conducted directly to the labyrinth by the cranial bones. In cases of disease of the sound-conducting mechanism, the sound of the tuning-fork is heard loudest in the *deaf* ear. Ed. Weber pointed out that, if one ear be stopped and a vibrating tuning-fork placed on the head, the sound is referred to the plugged ear, where it is heard loudest. It is assumed that when the ear is plugged, the sound-waves transmitted by the cranial bones are prevented from escaping (Mach). If, on the contrary, the sound be heard loudest in the good ear, then in all probability there is some affection of the sound-perceiving apparatus or labyrinth, although there are exceptions to this

statement, especially in elderly people. Another plan is to connect two telephones with an induction machine, provided with a vibrating Neef's hammer. The sounds of the vibrations of the latter are reproduced in the telephones, and if they be placed to the ears, then the healthy ears hear only *one* sound, which is referred to the middle line, and usually to the back of the head. In diseased conditions this is altered—it is referred to one side or the other.]

413. Structure of the Labyrinth, and Termination of the Auditory Nerve.

Scheme.—The *vestibule* (Fig. 441, III) contains two separate sacs, one of them the *sacculle*, *s* (round sac or *S. hemisphaericus*), communicates with the *ductus cochlearis*, *Cc*, of the cochlea, the other the *utricle*, *U* (elliptical sac, or *sacculus hemiellipticus*), communicates with the semicircular canals, *Cs*, *Cs*.

The *cochlea* consists of $2\frac{1}{2}$ turns of a tube disposed round a central column or *modiolus*. The tube is divided into two compartments (Fig. 427, Fig. 441, I) by a horizontal septum, partly osseous and partly membranous, the *lamina spiralis ossea* and *membranacea*. The *lower* compartment is the *scala tympani*, and is separated from the cavity of the tympanum by the membrane of the fenestra rotunda.

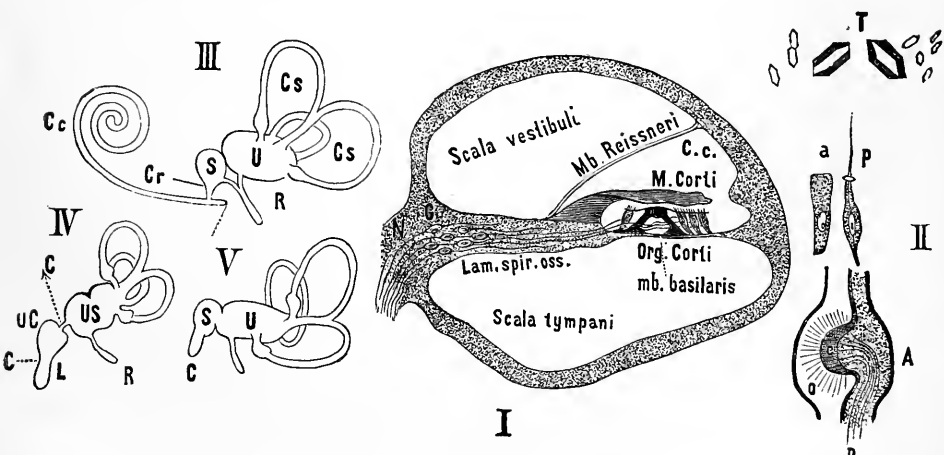

Fig. 441.

I, transverse section of a turn of the cochlea; II A, ampulla of a semicircular canal with the crista acustica; *a*, *p*, auditory cells; *p*, provided with a fine hair; *T*, otoliths; III, scheme of the human labyrinth; IV, scheme of a bird's labyrinth; V, scheme of a fish's labyrinth.

The *upper* compartment is the *scala vestibuli*, which communicates with the vestibule of the labyrinth (Fig. 441, I). These two compartments communicate directly by a small opening at the apex of the cochlea, a sickle-shaped edge [“hamulus”] of

the lamina spiralis bounding the *helicotrema* (Fig. 427). The scala vestibuli is divided by *Reissner's membrane* (Fig. 441, I), which arises near the outer part of the lamina spiralis ossea, and runs obliquely outwards to the wall of the cochlea so as to cut off a small triangular canal, the *ductus* or *canalis cochlearis*, or *scala media*, C c, whose floor is formed for the most part by the lamina spiralis membranacea, and on which the end-organ of the auditory nerve—Corti's organ—is placed. The lower end of the canalis cochlearis is blind, III, and divided towards the saccule, with which it communicates by means of the small *canalis reuniens*, Cr (Hensen). The *utricle* (Fig. 441, III, U) communicates with the three semicircular canals, C s, C s—each by means of an ampulla within which lies the terminations of the ampullary nerves, but, as the posterior and the superior canals unite, there is only one common ampulla for them. The membranous semicircular canals lie within the osseous canals, perilymph lying between the two. Perilymph also fills the scala vestibuli and tympani, so that all the spaces within the labyrinth are filled by fluid, while the spaces themselves are lined by short cylindrical epithelium.

The system of spaces, filled by endolymph, is the only part containing the nervous end-organs for hearing. All these spaces communicate with each other; the semicircular canals directly with the utricle, the ductus cochlearis with the saccule through the canalis reuniens; and, lastly, the saccule and utricle through the "sacculus endolympathicus," which springs by an isolated limb from each sac; the limbs then unite, as in the letter Y, and pass through the osseous aqueductus vestibuli to end blindly in the dura mater of the brain (Fig. III, R—Böttcher Retzius). The aqueductus cochleæ is another narrow passage which begins in the scala tympani, immediately in front of the fenestra rotunda, and opens close to the fossa jugularis. It forms a direct means of communication between the perilymph of the cochlea and the subarachnoid space.

Semicircular Canals and Vestibular Sacs.—The membranous semicircular canals do not fill the corresponding osseous canals completely, but are separated

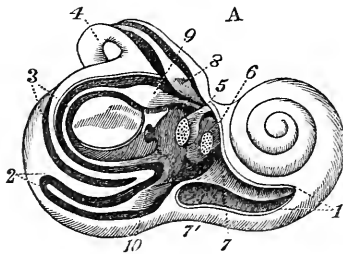

Fig. 442.

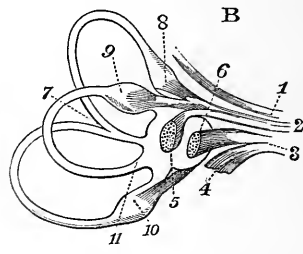

Fig. 443.

The interior of the right labyrinth with its membranous canals and nerves. In Fig. 442, A, the outer wall of the bony labyrinth is removed to show the membranous parts within—1, Commencement of the spiral tube of the cochlea; 2, posterior semicircular canal, partly opened; 3, horizontal; 4, superior canal; 5, utricle; 6, saccule; 7, lamina spiralis; 7', scala tympani; 8, ampulla of the superior membranous canal; 9, of the horizontal, 10, of the posterior canal. Fig. 443 shows the membranous labyrinth and nerves detached—1, Facial nerve in the internal auditory meatus; 2, anterior division of the auditory nerve giving branches to 5, 8, and 9, the utricle and the ampullæ of the superior and horizontal canals; 3, posterior division of the auditory nerve, giving branches to the saccule, 6, and posterior ampulla, 10, and cochlea, 4; 7, united part of the posterior and superior canals; 11, posterior extremity of the horizontal canal.

from them by a pretty wide space, which is filled with perilymph (Fig. 442). At the concave margin they are fixed by connective-tissue to the osseous walls. The ampullæ, however, completely fill the corresponding osseous dilatations. The canals and ampullæ consist externally of an outer, vascular, connective-tissue layer, on which there rests a well-marked hyaline layer, bearing a single layer of flattened epithelium.

Crista Acustica.—The vestibular branch of the auditory nerve sends a branch to each ampulla and to the saccule and utricle (Fig. 443). In the ampullæ (Fig. 441, II, A), the nerve (*c*) terminates in connection with the *crista acustica*, which is a yellow elevation projecting into the equator of the ampulla. The medullated nerve-fibres, *n*, form a plexus in the connective-tissue layer, lose their myelin as they pass to the hyaline basement membrane, and each ends in a cell provided with a rigid hair (*o, p*) 90 μ in length, so that the crista is largely covered with these hair-cells (Hartmann), but between them are supporting cells like cylindrical epithelium (*a*), and not unfrequently containing granules of yellow pigment. The hairs or "auditory hairs" (M. Schultze) are composed of many fine fibres (Retzius). An excessively fine membrane (*membrana tectoria*) covers the hairs (Pritchard, Lang).

Maculæ Acusticæ.—The nerve terminations in the maculæ acusticæ of the saccule and utricle are exactly the same as in the ampullæ, only the free surface of their *membrana tectoria* is sprinkled with small white chalk-like crystals or *otoliths* (II, T), composed of calcic carbonate, which are sometimes amorphous and partly in the form of arragonite, lying fixed in the viscid endolymph. The non-medullated axis cylinders of the saccular nerves enter directly into the substance

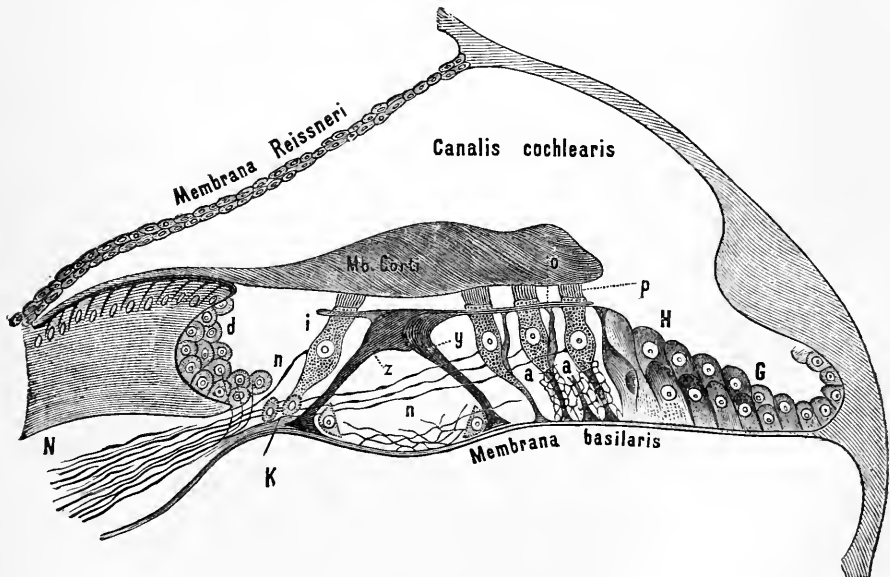

Fig. 444.

Scheme of the ductus cochlearis and the organ of Corti—N, cochlear nerve; K, inner, and P, outer hair-cells; *n*, nerve-fibrils terminating in P; *a, a*, supporting cells; *d*, cells in the sulcus spiralis; *z*, inner rod of Corti; Mb. Corti, membrane of Corti, or the *membrana tectoria*; *o*, the *membrana reticularis*; H, G, cells filling up the space near the outer wall.

of the hair-cells. The terminations of the nerves have been investigated, chiefly in fishes, in the rays.

Cochlea.—The terminations of the cochlear branch of the auditory nerve lie in connection with *Corti's organ*, which is placed in the canalis or ductus cochlearis (Fig. 441, I, C c, and III, C c, and Fig. 444), the small triangular chamber [or *scala media*], cut off from the *scala vestibuli* by the membrane of Reissner. Corti's organ is placed on the lamina spiralis membranacea, and consists of a *supporting apparatus* composed of the so-called Corti's arches, each of which consists of two Corti's rods (*z*, *y*), which lie upon each other like the beams of a house. But every two rods do not form an arch, as there are always three inner to two outer rods (Claudius). There are about 4,500 outer rods (Waldeyer).

The ductus cochlearis becomes larger towards the apex of the cochlea, and the rods also become longer; the inner ones are $30\ \mu$ long in the first turn, and $34\ \mu$ in the upper, the outer rods $47\ \mu$ and $69\ \mu$ respectively. The span of the arches also increases (Hensen). [The arches leave a triangular tunnel beneath them.] The proper end-organs of the cochlear nerve are the cylindrical "*hair-cells*" (Kölliker) previously observed by Corti, which are from 16,400 to 20,000 in number (Hensen, Waldeyer). There is *one* row of *inner* cells (*i*), which rests on a layer of small granular cells (K—Böttcher, Waldeyer); the *outer* cells (*a*, *a*) number 12,000 in man (Retzius), and rest upon the basement membrane, being disposed in three or even four rows. Between the outer hair-cells, there are other cellular structures, which are either regarded as special cells (*Deiter's cells*), or are regarded merely as processes of the hair-cells (Lavdowsky). [The cochlear branch of the auditory nerve enters the modiolus, and runs upwards in the osseous channels there provided for it, and, as it does so, gives branches to the lamina spiralis, where they run between the osseous plates which form the lamina.] The fibres (N) come out of the lamina spiralis after traversing the *ganglionic cells* in their course (Fig. 441, I, G), and end by fine varicose fibrils in the hair-cells (Fig. 444—Waldeyer, Gottstein, Lavdowsky, Retzius).

Membrana Reticularis.—Corti's rods and the hair-cells are covered by a special membrane (*o*), the *membrana reticularis* of Kölliker. The upper ends of the hair-cells, however, project through holes in this membrane, which consists of a kind of cement substance holding these parts together (Lavdowsky). [Springing from the outer end of the lamina spiralis, or crista spiralis, is the *membrana tectoria*, sometimes called the membrane of Corti. It is a well-defined structure, often fibrillated in appearance, and extends outwards over the organ of Corti.] Waldeyer regards it as a damping apparatus for this organ (Fig. 444, Mb. Corti).

Basilar Membrane.—Its breadth increases from the base to the apex of the cochlea. This fact is important in connection with the theory of the perception of tone. It is supposed that high notes are appreciated by structures in connection with the former, and low notes by the upper parts of the basilar membrane. In one case, recorded by Moos and Steinbrugge, a patient heard low notes only in the right ear, and after death it was found that the auditory nerve in the first turn of the cochlea was atrophied.]

Intra-Labyrinthine Pressure.—The lymph within the labyrinth is under a certain pressure. Every diminution of the pressure of the air in the tympanum is accompanied by a correspondingly short diminution of the intra-labyrinthine pressure, while, conversely, every increase of pressure is accompanied by an increase of the lymph-pressure (F. Bezold).

The perilymph of the inner ear flows away chiefly through the aqueductus cochleæ, in the circumference of the foramen jugulare, into

the peripheral lymphatic system, which also takes up the cerebro-spinal fluid of the subarachnoid space, while a small part drains away to the sub-dural space through the internal auditory meatus. The endo-lymph flows through the arachnoid sheath of the N. acusticus into the sub-arachnoid space (C. Hasse).

414. Quality of Auditory Perceptions—Perception of the Pitch and Strength of Tones.

Tones and Noises.—Every normal ear is able to distinguish *musical tones and noises*. Physical experiments prove that tones are produced when a vibrating elastic body executes *periodic* movements—*i.e.*, when the sounding body executes the same movement in equal intervals of time, as the vibrations of a string which has been plucked. A noise is produced by *non-periodic* movements—*i.e.*, when the sounding body executes unequal movements in equal intervals of time. [The non-periodic movements clash together on the ear, and produce dissonance, as when we strike the key-board of a piano at random.] This is readily proved by means of the *siren*. Suppose that there are forty holes in the rotatory disc of this instrument, placed at exactly the same distance from each other—on rotating the disc and directing a current of air against it, obviously with every rotation, the air will be rarefied and condensed exactly forty times. Every two condensations and rarefactions are separated from each other by an *equal* interval of time. This arrangement yields a characteristic *musical tone* or note. If a similar disc with holes perforated in it at *unequal* distances be used, on air being forced against it, a whirring non-musical *noise* is produced, because the movements of the sounding body (the condensations and rarefactions of the air) are *non-periodic*. [The double siren of v. Helmholtz is an improved instrument for showing the same facts.]

The normal ear also distinguishes in every tone *three* distinct factors :—

- [1. Intensity or force ;
2. Pitch ;
3. Quality, *timbre* or “*klang*.”]

1. The **intensity** of a tone depends upon the greater or lesser amplitude of the vibrations of the sounding body. Every one knows that a vibrating string emits a feebler sound when its excursions are smaller. (The intensity of a sound corresponds to the *degree of illumination or brightness* in the case of the eye.)

2. The **pitch** depends upon the *number* of vibrations which occur in

a given time (Mersenne, 1636), [or the length of time occupied by a single vibration]. This is proved by means of the siren. If the rotating disc have a series of forty holes at equal intervals, and another series of eighty equi-distant from each other, on blowing a stream of air against the rotating disc, we hear two sounds of unequal pitch, one being the octave of the other. (The perception of pitch corresponds to the *sensation of colour* in the case of the eye.)

3. The quality or timbre ("*Klangfarbe*") is peculiar to different sonorous bodies. [It is the peculiarity of a musical tone by which we are enabled to distinguish it as coming from a particular instrument, or from the human voice. Thus, the same note struck on a piano and sounded on a violin differs in quality or *timbre*.] It depends upon the *peculiar form of the vibration*, or the form of the wave of the sonorous body. (There is no analogous sensation in the case of light.)

I. Perception of Pitch.—By means of the organ of hearing, we can determine that different tones have a different pitch. In the so-called musical scale, or gamut, this difference is very marked to a normal ear. But in the scale there are again 4 tones, which, when they are sounded together, cause in a normal ear the sensation of an agreeable sound, which once heard can readily be reproduced. This is the tone of the so-called *Accord*, Triad, or Common Chord, consisting of the 1st, 3rd, and 5th tones of the scale, to which the 8th tone or octave is added. We have next to determine the pitch of the tones of the chord, and then that of the other tones of the scale. The siren is used for the fundamental experiment, from which the others can easily be calculated. Four concentric circles are drawn upon the rotatory disc of the siren; the inner circle contains 40 holes, the second 50, the third 60, and the outer 80—all the holes being at equal distances from each other. If the disc be rotated, and air forced against each series of holes *in turn*, we distinguish successively the four tones of the *accord* (major chord with its octave); when all the four series are blown upon *simultaneously*, we hear in complete purity the major chord itself. The *relative number of the holes* in the four series indicates in the simplest manner the relative pitch of the tones of the major chord. While one revolution of the disc is necessary to produce the *fundamental ground-tone* (key-note or tonic) with 40 condensations and rarefactions of the air—in order to produce the *octave*, we must have double the number of condensations and rarefactions during one revolution in the same time. Thus, the relation of the number of vibrations of the Ground-tone or Tonic to the octave next above it, is 1 : 2. In the second series we have 50 holes, which cause the pitch of the *Third*; hence, the relation of the Ground-tone to the Third in this case is 40 : 50, or 1 : $1\frac{1}{4} = \frac{5}{4}$ —*i.e.*, for every vibration of the Ground-tone there are $\frac{5}{4}$ vibrations in the Third. In the third series are 60 holes, which, when blown upon, yield the *Fifth*; hence, the ratio of the Ground-tone to the Fifth in our disc is 40 : 60, or 1 : $1\frac{1}{2} = \frac{3}{2}$. In the same way we can estimate the pitch of the Fourth tone, and we find that the number of vibrations of the First, Third, Fifth, and Octave are to each other as 1 : $\frac{5}{4}$: $\frac{3}{2}$: 2.

The Minor chord is quite as characteristic to a normal ear as the Major. It is distinguished essentially from the latter by its Third being half a tone lower. We can easily imitate it by the siren, as the *Minor Third* consists of a number of vibrations which stand to the Ground-tone as 6 : 5—*i.e.*, if 5 vibrations occur in a given time in the Ground-tone, then 6 occur in the Minor Third; its vibration number, therefore, is $\frac{6}{5}$.

From these relations of the Major and Minor common chords, we may calculate the relative tones in the scale, and we must remember that the Octave of a tone always yields the fullest and most complete harmony. It is evident that as the Major Third, the Minor Third, and the Fifth harmonise with the fundamental Ground-tone or key-note, they must also harmonise with the Octave of the key-note. We obtain from the Major Third with the number of vibrations $\frac{5}{4}$, the Minor Sixth with $\frac{8}{5}$; from the Minor Third with $\frac{6}{5}$, the Major Sixth = $(\frac{6}{5}) = \frac{3}{2}$; from the Fifth with $\frac{3}{2}$, the Fourth = $\frac{3}{4}$. These relations are known as the "Inversions of the Intervals." These relations of the tones are, collectively, the consonant intervals of the scale. The dissonant stages, or discords, of the scale can be obtained as follows:—Suppose that we have the Ground-tone or key-note C, with the number of vibrations = 1, the Third $E = \frac{5}{4}$, the Fifth $G = \frac{3}{2}$, and the Octave = 2, we then derive from the Fifth or Dominant G a Major chord—this is G, B, D'. The relative number of vibrations of these 3 tones is the same as in the Major chord of C, C, E, G. Hence, the number of vibrations of G : B is as C : E. When we substitute the values we obtain $\frac{3}{2} : B = 1 : \frac{5}{4}$ —i.e., $B = \frac{1}{5}$. But $D' : B = G : E$; so that $D : \frac{1}{5} = \frac{3}{2} : \frac{5}{4}$ —i.e., $D' = \frac{1}{8}$, or an octave lower, we have $D = \frac{1}{16}$. Deduce from F (sub-dominant) a Major chord, F, A, C'. The relation of A : C' = E : G, or $A : 2 = \frac{5}{4} : \frac{3}{2}$ —i.e., $A = \frac{5}{8}$. Lastly, $F : A = C : E$, or $F : \frac{5}{8} = 1 : \frac{5}{4}$ —i.e., $F = \frac{1}{2}$. So that all the tones of the scale have the following number of vibrations:—I., C = 1; II., D = $\frac{1}{8}$; III., E = $\frac{5}{4}$; IV., F = $\frac{1}{2}$; V., G = $\frac{3}{2}$; VI., A = $\frac{5}{8}$; VII., B = $\frac{1}{5}$; VIII., C' = 2.

Conventional Estimate of Pitch.—Conventionally, the pitch or concert-pitch of the note, *a*, is taken at 440 vibrations in the second (Scheibler, 1834), although in France it is taken at 435 vibrations per second. From this we can estimate the absolute number of vibrations for the tones of the scale: C = 33, D = 37.125, E = 41.25, F = 44, G = 49.5, A = 55, B = 61.875 vibrations. The number of vibrations of the next highest octave is found at once by multiplying these numbers by 2.

Musical Notes.—The *lowest* notes used in music are the double-bass, E, with 41.25 vibrations, pianoforte C with 33, grand piano A' with 27.5, and organ C' with 16.5. The *highest* notes in music are the pianoforte *c''* with 4,224, and *d''* on the piccolo-flute, with 4,752 vibrations per second.

Limits of Auditory Perception.—According to Preyer, the limit of the perception of the lowest audible tone lies between 16 and 23 vibrations per second, and *e''* with 40,960 vibrations as the highest audible tone; so that this embraces about $11\frac{1}{2}$ octaves.

[Audibility of Shrill Notes.—This varies very greatly in different persons (Wollaston). There is a remarkable falling off of the power as age advances (Galton). For *testing* this, Galton uses a small whistle (Fig. 445), made of a brass tube, with a diameter of less than $\frac{1}{16}$ th of an inch. A plug is fitted at the lower end to lengthen or shorten the tube, whereby the pitch of the note is altered. Amongst animals Galton finds none superior to cats in the power of hearing shrill sounds, and he attributes this "to differentiation by natural selection amongst these animals until they have the power of hearing all the high notes made by mice and other little creatures that they have to catch."]

Variations in Auditory Perception.—It is rare to find that tones produced by more than 35,000 vibrations per second are heard. When the tensor tympani



Fig. 445.

Galton's Whistle
(Krohne and
Sesemann).

is contracted, the perception may be increased for tones 3,000 to 5,000 vibrations higher, but rarely more. Pathologically, the perception for high notes may be abnormally acute—1. When the tension of the sound-conducting apparatus generally is increased. 2. By elimination of the sound-conducting apparatus of the middle ear, which offers greater or less resistance to the propagation of very high notes, as perforation of the membrana tympani, or loss of the incus and malleus. In these cases the stapes is directly set in vibration by the sound-waves, when tones up to 80,000 vibrations have been perceived. Diminished tension of the sound-conducting apparatus causes diminution of the perception for high tones (Blake).

A smaller number of vibrations than 16 per second (as in the organ) are no longer heard as a tone, but as single dull impulses. The tones that are produced beyond the highest audible note, as by stroking small tuning-forks with a violin bow, are also no longer heard as tones, but they cause a painful cutting kind of impression in the ear. In the musical scale the range is, approximately, from C of the first octave with 16·5 vibrations to e, the eighth octave.

Comparison of Ear and Eye.—In comparing the perception of the eye with that of the ear, we see at once that the range of accommodation of the ear is much greater. Red has 456 billions of vibrations per second, while the visible violet has but 667, so that the eye only takes cognisance of vibrations which do not form even 1 octave.

Lowest Audible Tone.—As to the *smallest* number of successive vibrations which the ear can perceive as a sensation of tone, Savart and Pfaundler considered that 2 would suffice. If, however, we exclude in our experiments the possibility of the occurrence of over-tones, 4 to 8 (Mach), or even 16 to 20 vibrations (F. Auerbach, Kohlrausch), are necessary to produce a characteristic tone.

When tones succeed each other rapidly, they are still perceived as distinct, when at least 0·1 second intervenes between two successive tones (v. Helmholtz); if they follow each other more rapidly they fuse with each other, although a short-time interval is sufficient for many musical tones.

By the term, "*fineness of the ear*," or, as we say, a "good ear," is meant the capacity of distinguishing from each other, as different, two tones of nearly the same number of vibrations. This power can be greatly increased by practice, so that musicians can distinguish tones that differ in pitch by only $\frac{1}{500}$, or even $\frac{1}{1200}$, of their vibrations.

With regard to the *time-sense*, it is found that beats are more precisely perceived by the ear than by the other sense-organs (Höring, Mach, Vierordt).

Pathological.—According to Lucæ, there are some ears that are better adapted for hearing *low* notes and others for *high* notes. Both conditions are disadvantageous for hearing speech. Those who hear low notes best hear the highest consonants imperfectly. The low notes are heard abnormally loud in rheumatic facial paralysis, while the high tones are heard abnormally loud in cases of loss of the membrana tympani, incus, and malleus. The stapedius is in full action, whereby the highest tones are heard louder at the expense of the lower notes. Many persons, with normal hearing, hear a tone higher with one ear than with the

other. This condition is called *dipacusis binauralis*. In rare cases sudden loss of the perception of certain tones has been observed, *e.g.*, the *bass-deafness* of Moos. In a case, described by Magnus, the tones, d^1 , b^1 , were not heard (§ 316).

II. **Perception of the Intensity of Tone.**—The *intensity* of a tone depends upon the *amplitude of the vibrations* of the sounding body. The intensity of the tone is proportional to the square of the amplitude of vibration of the sounding body, *i.e.*, with 2, 3, or 4 times the amplitude, the intensity of the tone is 4, 9, 16 times as strong. As sonorous vibrations are communicated to our ears by the wave-movements of the air, it is evident that the tones must become less and less intense, the further we are from the source of the sound. The intensity of the sound is inversely proportional to the square of the distance of the source of the sound from the ear.

Tests.—1. Place a watch horizontally near the ear, and test how close it may be brought to the ear, and also how far it may be removed, and still its sounds be heard. Measure the distance. 2. Itard uses a small hammer, suspended like a pendulum, and allowed to fall upon a hard surface. 3. Balls of different weights are allowed to fall from varying heights upon a plate. In this case the intensity of the sound is proportional to the product of the weight of the ball into the height it falls.

As to the **limits** of the perception of the intensity of a tone, it is found that a spherule weighing 1 milligram, and falling from a height of 1 mm. upon a glass plate, is heard at a distance of 5 centimetres (Schafhäütl).

415. Perception of Quality—Analysis of Vowels.

By the term **quality** ("Klangfarbe"), *musical colour* or *timbre*, is understood a peculiar character of the tone, by which it can be distinguished apart from its pitch and intensity. Thus, a flute, horn, violin, and the human voice may all sound the same note with equal intensity, and yet all the four are distinguished at once by their specific quality. Wherein lies the essence (*Wesen*) of tone-colour? The investigations of v. Helmholtz have proved that, amongst mechanisms which produce tones, only those that produce pendulum-like vibrations—*i.e.*, the to-and-fro vibrations of a metallic rod with one end fixed—and tuning-forks, execute simple pendulum-like vibrations. This can be shown by making a tuning-fork write off its vibrations on a recording surface, when a completely uniform wave-line, with equal elevations and depressions, is noted. The term "**tone**" is restricted to those sounds [hardly ever occurring in nature] which are due to simple pendulum-like vibrations. Other investigations have shown that the tones of musical instruments and of the human voice, all of which have a characteristic quality of their own, are composed of many single simple tones. Amongst these, *one* is characterised by its intensity, and at the same time it determines the pitch of the whole compound musical "tone-picture." This is called the **fundamental tone** or key-note. The other weaker tones which, as it were, spring from and are mingled with this, vary in different instruments both in intensity and number. They are "**upper tones**," and their vibrations are always some multiple—2, 3, 4, 5... times—of the fundamental tone or key-note. In general, we say that all those outbursts of sound, which embrace numerous strong upper tones, especially of high pitch, in addition to the fundamental tone, are characterised by a sharp, piercing, and rough quality, such as emanates from a trumpet or clarinet, and that, conversely, the quality is characterised by mildness and softness when the over-tones are few, feeble, and low—*e.g.*, such as are produced by the flute. It requires a well-trained musical ear to distinguish, in an instrumental burst, the over-tones apart from the fundamental tone. But this is

very easily done with the aid of **resonators** (Fig. 449). These consist of spherical or funnel-shaped hollow bodies, made of brass or some other substance, which, by means of a short tube, can be placed in the outer ear. If a resonator be placed in the ear, we can hear the feeblest over-tone of the same number of vibrations as the fundamental tone. Thus, musical instruments are distinguished by the number, intensity, and pitch of the over-tones which they produce. A vibrating metallic rod and a tuning-fork have no over-tones; they only give the fundamental tone. As already mentioned, the term *simple tone* is applied to sounds due to simple pendulum-like vibrations, while a sound composed of a fundamental tone and over-tones is called a "**klang**" or *compound musical tone*.

Vibration Curve of a Musical Tone.—When we remember that a musical tone or clang consists of a fundamental tone and a number of over-tones of a certain intensity, which determine its quality, then we ought to be able to construct geometrically the vibration curve of the musical tone. Let A represent

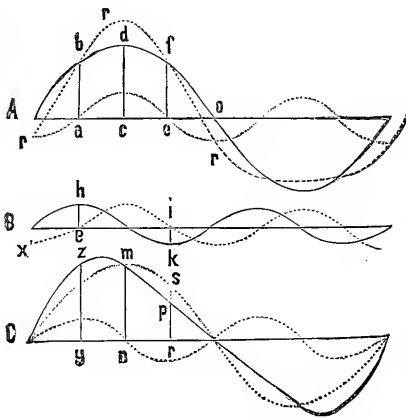

Fig. 446.

Curves of a musical tone obtained by compounding the curve of a fundamental tone with that of its over-tones.

the vibration curve of the fundamental tone, and B that of the first moderately weak over-tone (Fig. 446). The combination of these two curves is obtained simply by computing the height of the ordinates, whereby the ordinates of the over-tone curve, lying above the abscissa or horizontal line, are added to the fundamental tone curve, while those of the ordinates below the line are subtracted from it. Thus, we obtain the curve C, which is not a simple pendulum-like curve, but one which corresponds to an *unsteady* movement. A new curve of the second over-tone may be added to C, and so on. The result of all these combinations is that the vibration curves corresponding to the compound musical tones are *unsteady* periodic curves. All these curves must, of course, vary with the number and pitch of the compounded over-tone curves.

Displacement of the Phases.—The form of the vibration of one and the same musical tone may vary very greatly if, in compounding the curves A and B, the curve B is only slightly displaced laterally. If B is displaced so that the hollow of the wave, *r*, falls under A, the addition of both curves yields the curve, *r, r, r*, with small elevations and broad valleys. If B be displaced still further, until the elevation of the wave, *h*, coincides with A, we obtain still another form, so that by displacement of the *phases* of the wave-motions of the compounded, simple pendulum-like vibrations, we obtain numerous different forms of the same musical tone. The displacement of the phases, however, has no effect on the ear.

The general result of these observations, and those of Fourier, is that the quality of a musical tone depends upon the characteristic form of the vibratory movement.

Analysis of Vowels.—The human voice represents a reed instrument with vibrating elastic membranes, the vocal cords (§ 312). In uttering the various vowels the mouth assumes a characteristic form, so that its cavity has a certain fundamental tone peculiar to itself. Thus, to the fundamental tone of a certain pitch produced within the larynx, there are added certain over-tones which com-

municate to the laryngeal tone the vocal or vowel quality. Hence, a vowel is the timbre or quality of a musical tone which is produced in the larynx. The quality depends upon the number, intensity, and pitch of the over-tones, and the latter, again, depend on the configuration of the "vocal cavity" (§ 317) in uttering the different vowels.

Suppose a person to sing the vowels one after the other on a special note, *e.g.*, $b\flat$, we can, with the aid of resonators determine the over-tones, and in what intensity they are mixed with the fundamental tone, $b\flat$, to give the characteristic quality. According to v. Helmholtz, when we sound the vowels on $b\flat$, for each of the three vowels, *one* over-tone is specially characteristic for A- $b^{11}\flat$; for O- $b^1\flat$; for U-f. The other vowels and the diphthongs have each *two* specially characteristic over-tones, because, in these cases, the mouth is so shaped that the posterior larger cavity, and also the anterior narrower part, each yields a special tone (§ 316, I. and E). These two over-tones are for E- $b^{111}\flat$ and f^1 ; for I d^{iv} and f ; for Ä- g^{111} and d^{11} ; for Ö- $c^{111}\sharp$ and f^1 ; for Ü- g^{111} and f . These, however, are only the special upper tones. There are many more upper tones, but they are not so prominent.

Artificial Vowels.—Just as it is possible to analyse a vowel into its fundamental tone and its upper tones, it is possible to compound tones to produce the vowels by simultaneously sounding the fundamental tone and the corresponding upper tones. 1. A vowel is produced simply by singing loudly a vowel, *e.g.*, A, upon a certain note against the free strings of an open piano, whilst by the pedal the damper is kept raised. As soon as we stop singing, the characteristic vowel is sounded by the strings of the piano. The voice sets into sympathetic vibration all those strings whose over-tones (in addition to the fundamental tone) occur in the vocal compound tone, so that they vibrate for a time after the voice ceases (v. Helmholtz). 2. The vowel apparatus devised by v. Helmholtz consists of numerous tuning-forks, which are kept vibrating by means of electric magnets. The lowest tuning-fork gives the fundamental tone, $B\flat$, and the others the over-tones. A resonator is placed in front of each tuning-fork, and the distance between the two can be varied at pleasure. The resonators can be opened and closed by a lid passing in front of their openings. When the resonator is closed, we cannot hear the tone emitted by the tuning-fork placed in front of it; but when one or more resonators are opened, the tone is heard distinctly, and it is louder the more the resonator is opened. By means of a series of keys, like the keys of a pianoforte, we can rapidly open and close the resonators at will, and thus combine various over-tones with the fundamental tone so as to produce vowels with different qualities. V. Helmholtz makes the following compositions:—U = $B\flat$ with $b\flat$ weak and f^1 ; O = damped $B\flat$ with $b^1\flat$ strong and weaker $b\flat$, f^1 , d^{11} ; A = $b\flat$ (fundamental tone), with moderately strong $b^1\flat$ and f^1 , and strong $b^{11}\flat$ and d^{111} ; Ä = $b\flat$ (fundamental tone) with $b^1\flat$ and f^1 somewhat stronger than for A, d^{11} strong, $b^{11}\flat$ weaker, d^{111} and f^{111} as strong as possible; E = $b\flat$ (as fundamental tone) moderately strong, with $b^1\flat$ and f^1 moderate also, and f^{11} , $a^{111}\flat$, and $b^{111}\flat$, as strong as possible; I could not be produced.

In Appunn's apparatus, the fundamental tone and the over-tones are produced by means of organ pipes, whose notes can be combined to produce the vowels, but it is not so good as the tuning-forks, since the organ pipes do not yield simple tones, but, nevertheless, some of the vowels can be admirably reproduced with this apparatus.

Edison's Phonograph.—If we utter the vowels against a delicate membrane stretched over the end of a hollow cylinder, and if a writing style be fixed to the centre of the membrane, and the style be so arranged that it can write or record its movements on a piece of soft tin-foil arranged on a revolving apparatus, then the vowel curve is stamped, as it were, upon the tin-foil. If the style now be made to touch the tin-foil while the latter is moved, then the style is moved—it moves the membrane, and we hear distinctly by resonance the vowel sound reproduced.

[Koenig's Manometric Flames.—This is a most ingenious apparatus, and by means of it the quality of the vowel sounds is easily shown. It consists of a

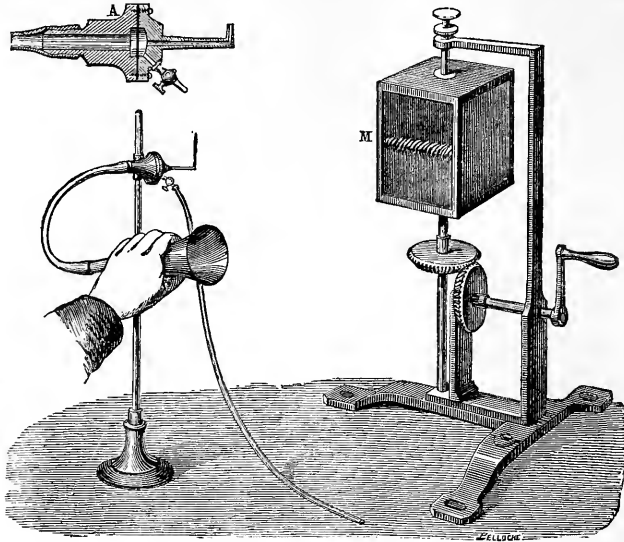

Fig. 447.

Koenig's manometric capsule (A) and mirror (M)—(Koenig)

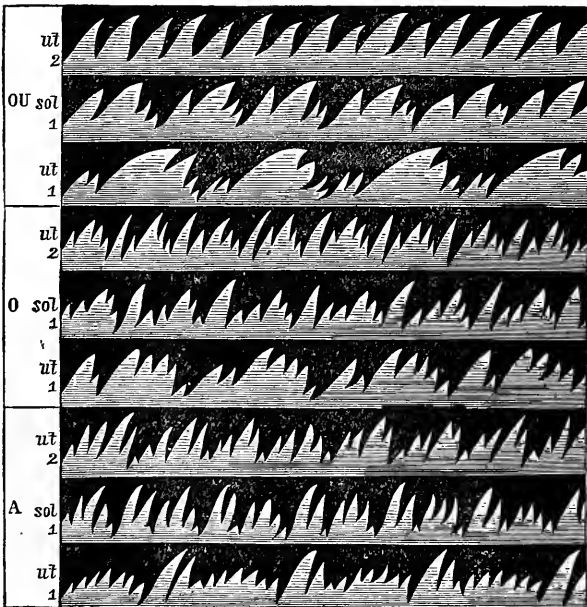

Fig. 448.

Flame-pictures of the vowels *ou*, *o*, and *u* (Koenig).

small wooden capsule, A, divided into two compartments by a piece of thin sheet india-rubber. Ordinary gas passes into the chamber on one side of the membrane, through the stop-cock, and it is lighted at a small burner. To the other compartment is attached a wider tube, with a mouth-piece. The whole is fixed on a stand (Fig. 447), and near it is placed a four-sided rotating mirror, M, as suggested by Wheatstone. On speaking or singing a vowel into the mouth-piece, and rotating the mirror, a toothed or zigzag flame-picture is obtained in the mirror. The form of the flame-picture is characteristic for each vowel, and varies, of course, with the pitch.]

[Fig. 448 shows the form of the flame-picture obtained in the rotating mirror when the vowels ou , o , a , are sung at the pitch of ut_1 , sol_1 , and ut_2 . This series shows how they differ in quality.]

[Koenig has also invented the apparatus (Fig. 449) for analysing any compound tone whose fundamental tone is ut_2 . It consists of a series of resonators, from ut_2 to ut_3 , fixed in an iron frame. Each resonator is connected with its special flame, which is pictured in a long, narrow, square rotating mirror. If a tuning-fork, ut_2 , be sounded, only the flame ut_2 is affected, and so on with each tuning-

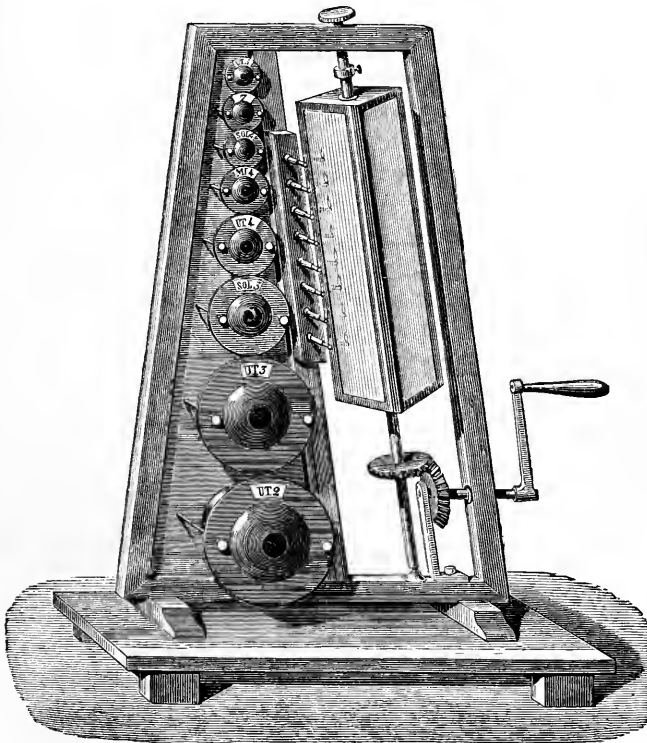

Fig. 449.

Koenig's apparatus for analysing a compound tone with the fundamental tone, ut_2 (Koenig).

fork of the harmonic series. Suppose a compound note containing the fundamental tone, ut_2 , and its harmonics be sounded, then the flame of ut_2 , and those

of the other harmonics in the note are also affected, so that the tone can be analysed optically. The same may be done with the vowels.]

416. Action of the Labyrinth during Hearing.

If we ask what rôle the ear plays in the perception of the *quality* of sounds, then we must assume that just as with the help of resonators, a musical note can be resolved into its fundamental tone and over-tones, so the ear is capable of performing such an analysis. The ear resolves the complicated wave-forms of musical tones into their components. These components it perceives as tones harmonious with each other; with marked attention each is perceived singly, so that the ear distinguishes as different tone-colours only different combinations of these simple tone-sensations. The resolution of complex vibrations due to quality into simple pendulum-like vibrations is a characteristic function of the ear. What apparatus in the ear is capable of doing this? If we sing vigorously—*e.g.*, the musical vowel A on a definite note, say b \flat —against the strings of an open pianoforte while the damper is raised, then we cause all those strings, and *only* those, to vibrate sympathetically, which are contained in the vowel so sung. We must, therefore, assume that an analogous sympathetic apparatus occurs in the ear, which is tuned, as it were, for different pitches, and which will vibrate sympathetically like the strings of a pianoforte. “If we could so connect every string of a piano with a nerve-fibre that the nerve-fibre would be excited and perceived as often as the string vibrated, then, as is actually the case in the ear, every musical tone which affected the instrument, would excite a series of sensations exactly corresponding to the pendulum-like vibrations into which the original movements of the air can be resolved; and thus the existence of each individual over-tone would be exactly perceived, as is actually the case with the ear. The perception of tones of different pitch would, under these circumstances, depend upon different nerve-fibres, and hence would occur quite independently of each other. Microscopic investigation shows that there are somewhat similar structures in the ear. The free ends of all the nerve-fibres are connected with small elastic particles, which we must assume are set into sympathetic vibration by the sound-waves” (v. Helmholtz).

Resolution by the Cochlea.—Formerly v. Helmholtz considered the rods of Corti to be the apparatus that vibrated and stimulated the terminations of the nerves. But, as birds and amphibians, which certainly can distinguish musical tones, have no rods (Hasse), the *stretched radial fibres of the membrana basilaris*, on which the organ of

Corti is placed, and which are shortest in the first turn of the cochlea, becoming longer towards the apex of the cochlea, are now regarded as the vibrating threads (Hensen). Thus, a string-like fibre of the membrana basilaris, which is capable of vibrating, corresponds to every possible simple tone. According to Hensen, the hairs of the labyrinth, which are of unequal length, may serve this purpose. Destruction of the apex of the cochlea causes deafness to deeper tones (Baginsky).

[**Hensen's Experiments.**—That the hairs in connection with the hair-cells vibrate to a particular note, is also rendered probable by the experiments of Hensen on the crustacean *Mysis*. He found that certain of the minute hairs (auditory hairs) in the auditory organ of this animal, situate at the base of the antennæ, vibrated when certain tones were sounded on a keyed horn. The movements of the hairs were observed by a low-power microscope. In mammals, however, there is a difficulty, as the hairs attached to the cells appear to be all about the same length. We must not forget that the perception of sound is a mental act.]

This assumption also explains the perception of *noises*.

Of noises in the strictly physical sense, it is assumed that they, like single impulses, are perceived by the aid of the saccules and the ampullæ.

It is assumed that the saccules and ampullæ are concerned in the general perception of hearing, *i.e.*, of shocks communicated to the auditory nerve (by impulses and noises); while by the cochlea we estimate the pitch and depth of the vibrations, and the musical character of the vibrations produced by tones.

The relation of the *semicircular canals* to the equilibrium of the body is referred to in § 350.

417. Simultaneous Action of two Tones—Harmony —Beats—Discords—Differential Tones.

When *two* tones of different pitch fall upon the ear simultaneously, they cause different sensations according to the difference in pitch.

1. **Consonance.**—If the number of vibrations of the two tones is in the ratio of simple multiples, as 1 : 2 : 3 : 4, so that when the low note makes one vibration, the higher one makes 2 : 3 or 4 . . . then we experience a sensation of complete harmony or concord.

2. **Interference.**—If, however, the two tones do not stand to each other in the relation of simple multiples, then when both tones are sounded simultaneously, *interference* takes place. The hollows of the one sound-wave can no longer coincide with the hollows of the other, and

the crests with the crests, but, corresponding to the difference of the number of vibrations of both curves, sometimes a wave-crest must coincide with a wave-hollow. Hence, when wave-crest meets wave-crest, there must be an *increase* in the strength of the tone, and when a hollow coincides with a crest, the sound must be weakened. Thus, we obtain the impression of those variations in tone intensity, which have been called "beats."

The number of vibrations is of course always equal to the difference of the number of vibrations of both tones. The beats are perceived most distinctly when two organ tones of low pitch are sounded together in unison, but slightly out of tune. Suppose we take two organ-pipes with 33 vibrations per second, and so alter one pipe that it gives 34 vibrations per second, then *one* distinct beat will be heard every second. The beats are heard more frequently, the greater the difference between the number of vibrations of the two tones.

Successive Beats.—The beats, however, produce very different impressions upon the ear according to the rapidity with which they succeed each other.

1. **Isolated Beats.**—When they occur at long intervals, we may perceive them as completely isolated, but single intensifications of the sound with subsequent enfeeblement, so that they give rise to the impression of *isolated beats*.

2. **Dissonance.**—When the beats occur more rapidly, they cause a continuous disagreeable whirring impression, which is spoken of as *dissonance*, or an unharmonious sensation. The greatest degree of unpleasant, painful dissonance occurs when there are 33 beats per second.

3. **Harmony.**—If the beats take place more rapidly than 33 times per second, the sensation of dissonance gradually diminishes, and it does so the more rapidly the beats occur. The sensation passes gradually from moderately inharmonious relations (which in music have to be resolved by certain laws) towards consonance or harmony. The tone relations are successively the Second, Seventh, Minor Third, Minor Sixth, Major Third, Major Sixth, Fourth and Fifth.

4. **Action of the Musical Tones** (*Klänge*).—Two musical "klangs," or compound tones, falling on the ear simultaneously, produce a result similar to that of two simple tones; but in this case we have to deal not only with the two fundamental tones, but also with the over-tones. Hence, the degree of dissonance of two musical tones is the more pronounced, the more the fundamental tones and the over-tones (and also the "differential" tones) produce beats which number about .33 per second.

5. **Differential Tones.**—Lastly, two "klangs," or two simple musical tones sounding simultaneously, may give rise to *new tones* when they

are uniformly and simultaneously sounding in corresponding intensity. We can hear, if we listen attentively, a third new tone, whose number of vibrations corresponds to the difference between the two primary tones, and hence it is called a "*differential tone*."

Summational Tones.—It was formerly supposed that new tones could arise from the summation or *addition* of their number of vibrations, but it has been shown that these tones are in reality differential tones of a high order (Appunn, Preyer).

418. Perception of Sound—Fatigue of the Ear—Objective and Subjective Audition—After Sensation.

Objective Auditory Perceptions.—When the stimulation of the terminations of the nerves of the labyrinth is referred to the outer world, then we have *objective auditory perceptions*. Such stimulations are only referred to the outer world, as are conveyed to the *membrana tympani* by vibrations of the air, as is shown by the fact that if the head be immersed in water, and the auditory meatuses be filled thereby, we hear all the vibrations as if they occurred within our head itself (Ed. Weber), and the same is the case with our own voice, as well as with the sound-waves conducted through the bones of the head, when both ears are firmly plugged.

Perception of Direction.—As to the perception of the direction whence sound comes, we obtain some information from the relation of both meatuses to the source of the sound, especially if we turn the head in the supposed direction of the sound. We distinguish the direction from which noises mixed with musical tones come more easily than that of tones (Rayleigh). When both ears are stimulated equally, we refer the source of the sound to the middle line anteriorly, but when one ear is stimulated more strongly than the other, we refer the source of the sound more to one side (Kessel). The position of the ear-muscles, which perhaps act like an ear-funnel, is important. According to Ed. Weber, it is more difficult to determine the direction of sound when the ears are firmly fixed to the side of the head. Further, if we place the hollow of both hands in front of the ear, as to form an open cavity behind them, we are apt to suppose that a sounding body placed in front is behind us.

The distance of a sound is judged of partly by the *intensity* or *loudness* of the sound, such as we have learned to estimate from sound at a known distance. But still we are subject to many misconceptions in this respect.

Amongst **subjective** auditory sensations are the *after vibrations*, especially of intense and continued musical tones; the *tinnitus aurium* which often accompanies

abnormal movements of the blood in the ear may be due to a mechanical stimulation of the auditory fibres, perhaps by the blood-stream (Brenner).

Entotal perceptions, which are due to causes within the ear itself, are such as hearing the *pulse-beats* in the surrounding arteries, and the rushing sound of the blood, which is especially strong when there is increased resonance of the ear, (as when the meatus or tympanum is closed, or when fluid accumulates in the latter), during increased cardiac action, or in hyperæsthesia of the auditory nerve (Brenner). Sometimes there is a cracking noise in the maxillary articulation, the noise produced by traction of the muscles on the Eustachian tube (p. 1055), and when air is forced into the latter, or when the membrana tympani is forced outwards or inwards (§ 350).

Fatigue.—The ear after a time becomes fatigued, either for one tone or for a series of tones which have acted on it, while the perceptive activity is not affected for other tones. Complete recovery, however, takes place in a few seconds (Urbantschitsch).

Auditory After Sensations.—1. Those that correspond to *positive* after sensations, where the after sensation is so closely connected with the original tone that both appear to be continuous. 2. There are some after sensations, where a pause intervenes between the end of the objective and the beginning of the subjective tone (Urbantschitsch). 3. There seems also to be a form corresponding to *negative* after images.

In some persons, the perception of a tone is accompanied by the occurrence of subjective colours, or the sensation of light, *e.g.*, the sound of a trumpet, accompanied by the sensation of yellow. More seldom are visual sensations of this kind observed when the nerves of taste, smell, or touch are excited (Nussbaumer, Lehmann and Bleuler). It is more common to find that an intense sharp sound is accompanied by an associated sensation of the sensory nerves. Thus, many people experience a cold shudder when a slate pencil is drawn in a peculiar manner across a slate.

[Colour Associations.—Colour is in some persons instantaneously associated with sound, and Galton remarks that it is rather common in children, although in an ill-developed degree, and the tendency seems to be very hereditary. Sometimes a particular colour is associated with a particular letter, vowel sounds particularly evoking colours. Galton has given coloured representations of these colour associations, and he points out their relation to what he calls *number-forms*, or the association of certain forms with certain numbers.]

An auditory impulse communicated to *one* ear at the same time often causes an increase in the auditory function of the *other* ear, in consequence of the stimulation of the auditory centres of *both* sides (Urbantschitsch, Eitelberg).

Other Stimuli.—The auditory apparatus, besides being excited by sound-waves, is also affected by heterologous stimuli. It is stimulated *mechanically* by a sudden blow on the ear. The effects of *electricity* and pathological conditions are referred to in § 350.

419. Comparative—Historical.

The lowest **fishes**, the cyclostomata (Petromyzon), have a saccule provided with auditory hairs containing otoliths, and communicating with two semicircular canals, while the myxinoïds have only one semicircular canal. Most of the other fishes, however, have a utricle communicating with three semicircular canals. In the carp, prolongations of the labyrinth communicate with the swimming bladder. In **amphibia**, the structure of the labyrinth is somewhat like that in fishes, but the cochlea is not typically developed. Most amphibia, except the

frog, are devoid of a *membrana tympani*. Only the *fenestra ovalis* (not the *rotunda*) exists, and it is connected in the frog by three ossicles with the freely-exposed *membrana tympani*. Amongst **reptiles**, the appendix to the sacculæ, corresponding to the cochlea, begins to be prominent. In the tortoise it is saccular, but in the crocodiles it is longer, and somewhat curved and dilated at the end. In all reptiles the *fenestra rotunda* is developed, whereby the cochlea is connected with the labyrinth. In crocodiles and birds the cochlea is divided into a *scala vestibuli* and *S. tympani*. Snakes are devoid of a tympanic cavity. In birds, both sacculæ (Fig. 441, IV., U S') are united (Hasse), the canal of the cochlea (U C), which is connected by means of a fine tube (C), with the sacculæ, is larger, and shows indications of a spiral arrangement, and has a flask-like blind end, the *lagena* (L). The auditory ossicles in reptiles and birds are reduced to *one* column-like rod, corresponding to the stapes, and called the *columella*. The lowest **mammals** (*Echidna*) have structures very like those of birds, while the higher mammals have the same type as in man (Fig. 441, III). The Eustachian tube is always open in the whale.

Amongst **invertebrata**, the auditory organ is very simple in *medusæ* and *mollusca*. It is merely a bladder filled with fluid, with the auditory nerves provided with *ganglia* in its walls. Hair-cells occur in the interior, provided with one or more *otoliths*. Hensen observed that in some of the *annulosa*, when sound was conducted into the water, some of the auditory bristles vibrated, being adapted for special tones. In *cephalopoda*, we distinguish the first differentiation into a membranous and cartilaginous labyrinth.

Historical.—Empedocles (473 B.C.) referred auditory impressions to the cochlea. The Hippocratic School was acquainted with the *tympanum*, and Aristotle (384 B.C.) with the Eustachian tube. Vesalius (1561) described the *tensor tympani*; Cardanus (1560) the conduction through the bones of the head; while Fallopius (1561) described the vestibule, the *semicircular canals*, *chorda tympani*, the two *fenestræ*, the cochlea, and the aqueduct. Eustachius († 1570) described the *modiolus*, the *lamina spiralis* of the cochlea, the Eustachian tube, as well as the muscles of the ear; Plater the *ampullæ* (1583); Casseri (1600) the *lamina spiralis membranacea*. Sylvius (1667) discovered the ossicle called by his name; Vesling (1641) the *stapedius*. Mersenne (1618) was acquainted with over-tones; Gassendus (1658) experimented on the conduction of sound. Acoustics was greatly advanced by the work of Chladni (1802). The most recent and largest work on the ear in vertebrates is by G. Retzius (1881-84).

The Organ of Smell.

420. Structure of the Organ of Smell.

Regio Olfactoria.—The area of the distribution of the olfactory nerve is the *regio olfactoria*, which embraces the upper part of the septum, the upper (Fig. 451, Cs), and part of the middle (Cm) turbinated bone. All the remainder of the nasal cavity is called the *regio respiratoria*. These two regions are distinguished as follows:—1. The *regio olfactoria* has a thicker mucous membrane. 2. It is covered by a single layer of cylindrical epithelium (Fig. 450, E), the cells

being often branched at their lower ends, and contain a yellow or brownish-red pigment. 3. It is coloured by this pigment, and is thereby distinguished from the uncoloured regio respiratoria, which is covered by ciliated epithelium. 4. It

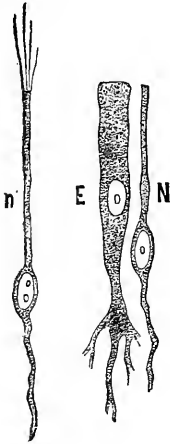

Fig. 450.

N, olfactory cells (human); *n*, from the frog; E, epithelium of the regio olfactoria.

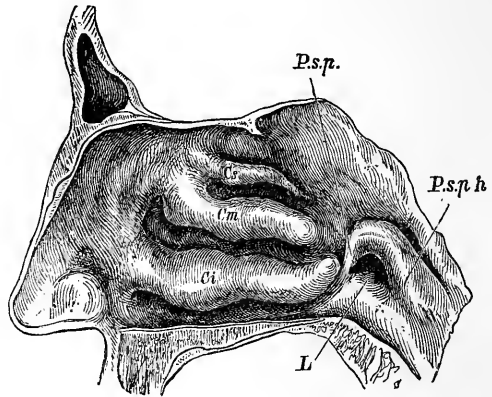

Fig. 451.

Nasal and pharyngo-nasal cavities—L, levator elevation; P.s.p., plica salpingo-palatina; Cs, Cm, Ci, the three turbinated bones (Urbantschitsch).

contains peculiar tubular glands (*Bowman's glands*), while the rest of the mucous membrane contains numerous acinous *serous glands* (Heidenhain). 5. Lastly, the regio olfactoria embraces the end-organs of the olfactory nerve (M. Schultze). The long narrow *olfactory cells* (N) are distributed between the ordinary cylindrical epithelium (E) covering the regio olfactoria. The body of the cell is spindle-shaped, with a large nucleus containing nucleoli, and it sends upwards between the cylindrical cells a narrow (0.9 to 1.8μ) smooth rod, quite up to the free surface of the mucous membrane. In the frog (*n*), the free end carries delicate projecting hairs or bristles. In the deeper part of the mucous membrane, the olfactory cells pass into, and become continuous with varicose fine nerve-fibres, which pass into the olfactory nerve (§ 321, I. 1). According to C. K. Hoffmann and Exner, after section of the olfactory nerve, the specific olfactory end-organs become changed into cylindrical epithelium (frog), and in warm-blooded animals, they undergo fatty degeneration, even on the 15th day. V. Brunn found a homogeneous limiting membrane, which had holes in it for transmitting the processes of the olfactory cells only.

421. Olfactory Sensations.

Olfactory sensations are produced by the action of gaseous, odorous substances being brought into direct contact with the olfactory cells, during the act of *inspiration*. The current of air is divided by the anterior projection of the lowest turbinated bone, so that a part above

the latter is conducted to the regio olfactoria. Odorous bodies taken into the mouth and then expired through the posterior nares are said not to be smelt (Bidder).

During inspiration, the air streams along close to the septum, while little of it passes through the nasal passages, especially the superior (Paulsen and Exner).

The *first* moment of contact between the odorous body and the olfactory mucous membrane appears to be the time when the sensation takes place, as, when we wish to obtain a more exact perception, we *sniff* several times, *i.e.*, a series of rapid inspirations are taken, the mouth being kept closed. During sniffing, the air within the nasal cavities is rarefied, and as air rushes in to equilibrate the pressure, the air, laden with odorous particles, streams over the olfactory region. Odorous fluids are said not to give rise to the sensation of smell when they are brought into direct contact with the olfactory mucous membrane, as by pouring eau de Cologne into the nostrils (Tourtual, 1827; E. H. Weber, 1847). This is, perhaps, due to the action of the fluid on the olfactory cells, paralysing them, perhaps owing to imbibition, shrivelling, or chemical action. Even water alone temporarily affects the cells. We know practically nothing about the nature of the action of odorous bodies, but many odorous vapours have a considerable power of absorbing heat (Tyndall).

The **intensity** of the sensation depends on—1. The size of the olfactory surface, as animals with a very keen sense of smell are found to have complex turbinated bones covered by the olfactory mucous membrane. 2. The concentration of the odorous mixture of the air. Still, some substances may be attenuated enormously (*e.g.*, musk to the two-millionth of a milligram), and still be smelt. 3. The frequency of the conduction of the vapour to the olfactory cells (sniffing).

[The **acuteness** of the sense of smell is greatly improved by practice. A boy named James Mitchell, who was deaf, dumb, and blind, used his sense of smell, like a dog, to distinguish persons and things.]

Electrical, chemical, or thermal stimuli do not give rise to olfactory sensations. [Althaus found that electrical stimulation of the olfactory mucous membrane gave rise to the sensation of the smell of phosphorus.]

The **variations** are referred to in § 343. If the two nostrils are filled with different odorous substances, there is no mixture of the odours, but we smell sometimes the one and sometimes the other (Valentin). The sense of smell, however, is very soon blunted, or even paralysed. Morphia, when mixed with a little sugar and taken as snuff, paralyses the olfactory apparatus, while strychnin makes it more sensitive (Lichtenfels and Fröhlich).

The **sensory** nerves of the nasal mucous membrane (§ 347, II.), [*i.e.* those supplied from the fifth cranial nerve], are stimulated by irritating vapours, and may even cause pain, *e.g.*, ammonia and acetic acid. In a very diluted condition, they may even act on the olfactory nerves. The nose is useful as a sentinel for

guarding against the introduction of disagreeable odours and foods. The sense of smell is aided by the sense of taste, and conversely.

[**Flavour** depends on the sense of smell, and, to test it, use substances, solid or fluid, with an *aroma* or *bouquet*, such as wine or roast beef.]

[**Method of Testing.**—In doing so, avoid the use of pungent substances like ammonia, which excite the fifth nerve. Use some of the essential volatile oils, such as cloves, bergamot, and the foetid gum resins, or musk and camphor. Electrical stimuli are not available.]

Comparative.—In the lowest *vertebrata*, pits, or depressions provided with an olfactory nerve, represent the simplest olfactory organ. Amphioxus and the cyclostomata have only *one* olfactory pit; all other vertebrates have two. In some animals (frog), the nose communicates with the mouth by ducts. The olfactory nerve is absent in the whale.

Historical.—Rufus Ephesius (97 A.D.) described the passage of the olfactory nerve through the ethmoid bone. Rudius (1600) dissected the body of a man with congenital anosmia, in whom the olfactory nerves were absent. Magendie originally supposed that the nasal branch of the fifth was the nerve of smell, a view successfully combated by Eschricht.

The Organ of Taste.

422. Position and Structure of the Gustatory Organs.

Gustatory Region.—There is considerable difference of opinion as to what regions of the mouth are endowed with taste:—1. The root of the tongue in the neighbourhood of the circumvallate papillæ, the area of distribution of the glosso-pharyngeal nerve, is undoubtedly endowed with taste (§ 351). 2. The tip and margins of the tongue are gustatory, but there are very considerable variations (Urbantschitsch). 3. The lateral part of the soft palate and the glosso-palatine arch are endowed with taste from the glosso-pharyngeal nerve. 4. It is uncertain whether the hard palate (Drielsma) and the entrance to the larynx are endowed with taste. The middle of the tongue is not gustatory.

Taste-bulbs.—The *end-organs* of the gustatory nerves are the taste-bulbs discovered by Schwalbe and Lovén (1867). They occur on the lateral surfaces of the circumvallate papillæ (Fig. 452, I), also upon the opposite side, K, of the fossa or capillary slit, R R, which surrounds the central eminence or papilla; they occur more rarely on the surface. They also occur on the fungiform papillæ, in the papillæ of the soft palate and uvula (A. Hoffman), on the under surface of the epiglottis, the upper part of the posterior surface of the epiglottis, and the

inner side of the arytenoid cartilages (Verson, Davis), and on the vocal cords (Sinianowsky). Many buds or bulbs disappear in old age.

Structure.—The taste-bulbs are $51\ \mu$ high, and $33\ \mu$ thick, are barrel-shaped and embedded in the thick stratified squamous epithelium of the tongue. Each bulb consists of a series of lancet-shaped, bent, nucleated, outer, *supporting or protective* cells, arranged like the staves of a barrel (Fig. 452, II, D, isolated in III, d). They are so arranged as to leave a small opening, or the "*gustatory pore*" at the

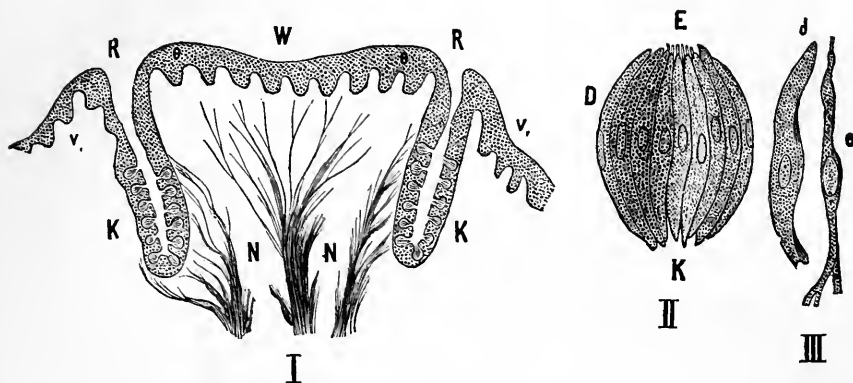

Fig. 452.

I, Transverse section of a circumvallate papilla; W, the papilla; v_1, v_1 , the wall in section; R, R, the circular slit or fossa; K, K, the taste-bulbs in position; N, N, the nerves. II, Isolated taste-bulb; D, supporting or protective cells; K, under end; E, free end, open, with the projecting apices of the taste-cells. III, Isolated protective cell (d) with a taste-cell (e).

free end of the bulb. Surrounded by these cells and lying in the axis of the bud are 1-10 **gustatory cells** (II, E), some of which are provided with a delicate process (III, e) at their free ends, while their lower fixed ends send out basal processes, which become continuous with the terminations of the nerves of taste, which have become non-medullated. After section of the glosso-pharyngeal, the taste-buds degenerate, while the protective cells become changed into ordinary epithelial cells within four months (v. Vintschgau and Hönigschmied). Very similar structures were found by Leydig in the skin of fresh-water fishes. The *glands* of the tongue and their secretory fibres from the 9th cranial nerve (Drasch) are referred to in § 141.

423. Gustatory Sensations.

Varieties.—There are *four* different gustatory qualities, the sensations of

1. *Sweet.*
2. *Bitter.*
3. *Acid.*
4. *Saline.*

Acid and saline substances at the same time also stimulate the sensory nerves of the tongue, but when greatly diluted, they only excite the

end-organs of the specific nerves of taste. Perhaps there are special nerve-fibres for each different gustatory quality (v. Vintschgau).

Conditions.—Sapid substances, in order that they may be tasted, require the following conditions:—They must be *dissolved* in the fluid of the mouth, especially substances that are solid or gaseous. The **intensity** of the gustatory sensation depends on:—1. The *size of the surface* acted on. Sensation is favoured by rubbing in the substance between the papillæ, in fact, this is illustrated in the rubbing movements of the tongue during mastication (§ 354). 2. The *concentration* of the sapid substance is of great importance. Valentin found that the following series of substances ceased to be tasted in the order here stated, as they were gradually diluted—syrup, sugar, common salt, aloes, quinine, sulphuric acid. Quinine can be diluted 20 times more than common salt and still be tasted (Camerer). 3. The *time* which elapses between the application of the sapid substance and the production of the sensation varies with different substances. Saline substances are tasted most rapidly (after 0·17 second, according to v. Vintschgau), then sweet, acid and bitter (quinine after 0·258 second, v. Vintschgau). This even occurs with a mixture of these substances (Schirmer). The last-named substances produce the longest “*after-taste*.” 4. The *delicacy* of the sense of taste is partly congenital, but it can be greatly improved by practice. If a person uses the same sapid substance, or a nearly related one, or even any very intensely sapid substance, the sense of taste is soon affected, and it becomes impossible to give a correct judgment as to the taste of the sapid body. 5. Taste is greatly aided by the sense of *smell*, and in fact, we often confound taste with smell; thus, vanilla, garlic and assafoetida only affect the organ of smell, while chloroform only excites taste. [The combined action of taste and smell in some cases gives rise to *flavour* (p. 1080).] The eye even may aid the determination, as in the experiment where in rapidly tasting red and white wine one after the other, when the eyes are covered, we soon become unable to distinguish between the one and the other. 6. The most advantageous *temperature* for taste is between 10–35°C.; hot and cold water temporarily paralyse taste.

Action of the Electrical Current.—The *constant current*, when applied to the tongue, excites, both during its passage, and when it is opened or closed, a sensation of acidity at the + pole, and at the - pole an alkaline taste, or, more correctly, a harsh burning sensation (Sulzer, 1752). This is not due to the action of the electrolytes of the fluid in the mouth, for, even when the tongue is moistened with an acid fluid, the alkaline sensation is experienced at the - pole (Volta). We cannot, however, set aside the supposition that perhaps electrolytes, or decomposition products, may be formed in the deeper parts and excite the gustatory fibres. Rapidly interrupted currents do not excite taste (Grünhagen). V. Vintschgau, who has only incomplete taste on the tip of the tongue, finds that when the *tip* of the tongue is traversed by an electrical current, there is never a

gustatory sensation, but always a distinct tactile one. In experiments on Hönigschmied, who is possessed of normal taste in the tip of the tongue, there was often a metallic or acid taste at the + pole on the tip of the tongue, while at the - pole taste was often absent, and when it was present, it was almost always alkaline, and acid only exceptionally. After interrupting the current, there was a metallic after-taste with both directions of the current.

[**Testing Taste.**—Direct the person to put out his tongue and close his eyes, and, after drying the tongue, apply the sapid substance by means of a glass rod, or a small brush. Try to confine the stimulus as much as possible to one place, and after each experiment rinse the mouth with water. A wine-taster chews an olive to “clean the palate,” as he says. For testing *bitter* taste use a solution of quinine or quassia; for *sweet*, sugar; *saline*, common salt; and *acid*, dilute citric or acetic acid. The galvanic current may also be used.]

Pathological.—Diseases of the tongue, as well as dryness of the mouth caused by interference with the salivary secretion, interfere with the sense of taste. **Subjective gustatory** impressions are common amongst the insane, and are due to some central cause, perhaps to irritation of the psychogeuic centre (§ 378, IV., 3). After poisoning with santonin, a bitter taste is experienced, while, after the subcutaneous injection of morphia, there is a bitter and acid taste. The terms *hypergeusia*, *hypogeusia*, and *ageusia* are applied to the increase, diminution, and abolition of the sense of taste. Many tactile impressions on the tongue are frequently confounded with gustatory sensations—*e.g.*, the so-called biting, cooling, prickling, sandy, mealy, astringent, and harsh tastes.

Comparative.—About 1,760 taste-bulbs occur on the circumvallate papillæ of the ox. The term *papilla foliata* is applied to a large folded gustatory organ placed laterally on the side of the tongue, especially of the rabbit (Rapp, 1832), and which in man is represented by analogous organs, composed of longitudinal folds, lying in the fimbriæ linguæ on each side of the posterior part of the tongue (Krause, v. Wyss). Taste-bulbs are absent in reptiles and birds. They are numerous in the mouth of the tadpole (F. E. Schultze), while the tongue of the frog is covered with epithelium resembling gustatory cells (Billoth, Axel Key). The goblet-shaped organs in the skin of fishes and tadpoles have a structure similar to the taste-bulbs, and may perhaps have the same function. There are taste-bulbs in the mouth of the carp and ray.

Historical.—Bellini regarded the papillæ as the organs of taste (1711). Richerand, Mayo, and Fodera thought that the lingual was the only nerve of taste, but Majendie proved that, after it was divided, the posterior part of the tongue was still endowed with taste. Panizza (1834) described the glosso-pharyngeal as the nerve of taste, the gustatory as the nerve of touch, and the hypoglossal as the motor nerve of the tongue.

The Sense of Touch.

424. Terminations of Sensory Nerves.

1. The touch-corpuscles of Wagner and Meissner lie in the papillæ of the cutis vera (§ 283), and are most numerous in the palm of the hand and the sole of

the foot, especially in the fingers and toes, there being about 21 to every square millimetre of skin, or 108 to 400 of the papillæ containing blood-vessels. They are less abundant on the back of the hand and foot, mamma, lips, and tip of the tongue, rare on the glans clitoridis, and occur singly and scattered on the volar side of the fore-arm, even in the anthropoid apes. They are oval or elliptical bodies, 40-200 μ long [$\frac{1}{3000}$ in.], and 60-70 μ broad [$\frac{1}{5000}$ to $\frac{1}{3000}$ in.], and are covered externally by layers of connective-tissue arranged transversely in layers, and within is a granular mass with elongated striped nuclei (Fig. 453, *e*). One to three medullated nerve-fibres pass to the lower end of each corpuscle, and surround it in a spiral manner two or three times; the fibres then lose their myelin, and, after dividing into 4-6 fibrils, divide within the corpuscle. The exact mode of termination of the fibrils is not known. Some observers suppose that the transverse fibrillation is due to the coils or windings of the nerve-fibrils; while, according to others, the inner part consists of numerous flattened cells lying one over the other, between which the pale terminal fibres end, either in swellings or with disc-like expansions, such as occur in Merkel's corpuscles.

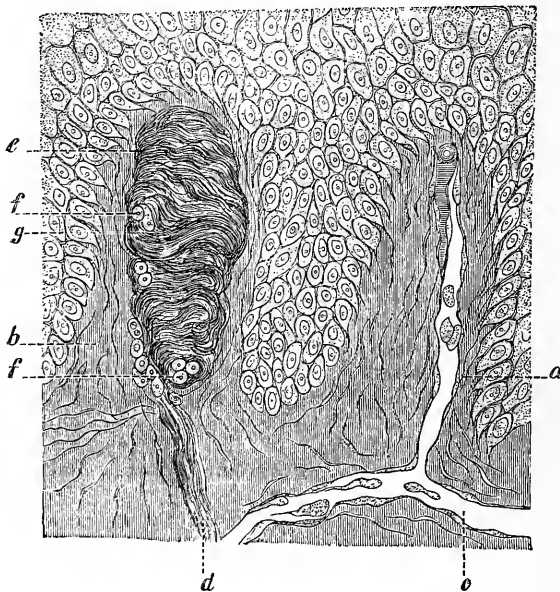

Fig. 453.

Vertical section of the skin of the palm of the hand—*a*, Blood-vessel; *b*, papilla of the cutis vera; *c*, capillary; *d*, nerve-fibre passing to a touch-corpuscle; *f*, nerve-fibre divided transversely; *e*, Wagner's touch-corpuscle; *g*, cells of the Malpighian layer of the skin (after Biesiadecki).

[These corpuscles do not contain a soft core such as exists in Pacini's corpuscles. The corpuscles appear to consist of connective-tissue with imperfect septa passing into the interior from the fibrous capsule. After the nerve-fibre enters, it loses its myelin, and then branches, while the branches anastomose and follow a spiral course within the corpuscle, finally to terminate in slight enlargements. According to Thin, there are simple and compound corpuscles, depending on the number of nerve-fibres entering them.]

Kollmann describes three special tactile areas in the hand:—1. The tips of the fingers with 24 touch-corpuscles in a length of 10 mm.; 2. the three eminences lying on the palm behind the slits between the fingers, with 5·4-2·7 touch-corpuscles in the same length; and 3. the ball of the thumb and little finger with 3·1-3·5 touch-corpuscles. The first two areas also contain many of the corpuscles of Vater or Pacini, while in the latter these corpuscles are fewer and scattered. In the other parts of the hand, the nervous end-organs are much less developed.

Vater's (1741) or Pacini's corpuscles are oval bodies (Fig. 454), 1-2 mm. long, lying in the subcutaneous tissue on the nerves of the fingers and toes (600-1400), in the neighbourhood of joints and muscles, the sympathetic abdominal plexuses, near the aorta and coccygeal gland, on the dorsum of the penis and clitoris, and in the mesocolon [and mesentery] of the cat. [They also occur in the course of the intercostal and periosteal nerves, and Stirling has seen them in the capsule of lymphatic glands. They are attached to the nerves of the hand and feet, and are so large as to be visible to the naked eye, both in these regions and between the layers of the mesentery of the cat. They are whitish or somewhat transparent, with a white line in the centre (cat); in man, they are $\frac{1}{5}$ to $\frac{1}{6}$ inch long, and $\frac{3}{5}$ to $\frac{1}{2}$ inch broad, and are attached by a stalk or pedicle (Fig. 454, *a*) to the nerve.] They consist of numerous nucleated connective-tissue capsules or lamellæ lined by endothelium, separated from each other by fluid, and lying one within the other like the coats of an onion, while in the axis is a *central core*. A medullated nerve-fibre passes to each, where its sheath of Schwann unites with the capsule. It loses its myelin, and passes into the interior as an axial cylinder (Fig. 454, *e*), where it either ends in a small knob or may divide dichotomously (Fig. 454, *f*), each branch terminating in a small pear-shaped enlargement. [Each large corpuscle is covered by 40-50 lamellæ, or tunics, which are thinner and closer to each other (Fig. 454, *d*) internally than in the outer part, where they are thicker and wider apart. The lamellæ are like the laminae in the lamellated sheath of a nerve, and are composed of an elastic basis mixed with white fibres of connective-tissue, while the inner surface of each lamella is lined by a single continuous layer of endothelium continuous with that of the perineurium. It is easily stained with silver nitrate. The *efferent nerve-fibre* is covered with a thick sheath of lamellated connective-tissue (sheath of Henle), which becomes blended with the outer lamellæ of the corpuscle. The medullated nerve is sometimes accompanied by a blood-vessel, and pierces the various tunics, retaining its myelin until it reaches the core, where it terminates as already described.]

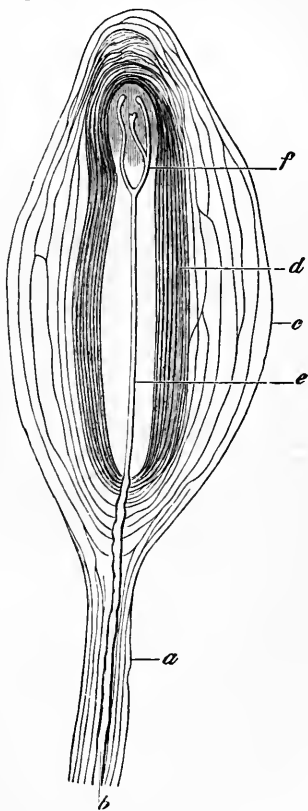

Fig. 454.

Vater's or Pacini's corpuscle —
a, Stalk; *b*, nerve-fibre entering it; *c*, *d*, connective-tissue envelope; *e*, axis cylinder, with its end divided at *f*.

3. **Krause's end-bulbs** very probably occur as a regular mode of nerve termi-

nation in the cutis and mucous membranes of all mammals. They are elongated, oval, or round bodies, 0.075 to 0.14 mm. long, and have been found in the deeper layers of the conjunctiva bulbi, floor of the mouth, margins of the lips, nasal mucous membrane, epiglottis, fungiform and circumvallate papillæ, glans penis and clitoris, volar surface of the toes of the guinea-pig, ear and body of the mouse, and in the wing of the bat. [In the calf, the "*cylindrical end-bulbs*" are oval, with a nerve-fibre terminating within them. The sheath of Henle becomes continuous with the nucleated capsule, while the axial cylinder, devoid of its myelin, is continued into the soft core. In man, the end-bulbs are "spheroidal," and consist of a nucleated connective-tissue capsule continuous with Henle's sheath of the nerve, and enclosing many cells, amongst which the axis cylinder, which enters the bulb, branches and terminates.] The spheroidal and end-bulbs occur in man, in the nasal mucous membrane, conjunctiva, mouth, epiglottis, and the mucous folds of the rectum. According to Waldeyer and Longworth, the nerve-fibrils terminate in the cells within the capsule. These cells are said to be comparable to Merkel's tactile cells (Waldeyer).

The *genital corpuscles* of Krause, which occur in the skin and mucous membrane of the glans penis, clitoris, and vagina, appear to be end-bulbs more or less fused together.

The *articulation nerve-corpuscles* occur in the synovial mucous membrane of the joints of the fingers. They are larger than the end-bulbs, and have numerous oval nuclei externally, while one to four nerve-fibres enter them.

4. *Tactile or touch-corpuscles of Merkel*, sometimes also called the corpuscles of Grandry, occur in the beak and tongue of the duck and goose, in the epidermis of man and mammals, and in the outer root-sheath of tactile hairs or feelers. They are small bodies composed of a capsule enclosing two, three, or more large, granular, somewhat flattened nucleated and nucleolated cells, piled one on the other in a vertical row, like a row of cheeses. Each corpuscle receives at one side a medullated nerve-fibre, which loses its myelin, and branches to terminate, according to some observers (Merkel), in the cells themselves, and according to others (Ranvier, Izquierdo, Hesse), in the protoplasmic transparent substance or disc lying between the cells. [This intercellular disc is the "*disc tactil*" of Ranvier, or the "*Tastplatte*" of Hesse.] When there is a great aggregation of these cells, large structures are formed which appear to form a kind of transition between these and touch-corpuscles. [According to Klein, the terminal fibrils end neither in the touch-cells or tactile disc, but in minute swellings in the interstitial substance between the touch-cells, in a manner very similar to that occurring in the end-bulbs.]

[According to Merkel, tactile cells, either isolated or in groups, but in the latter case never forming an independent end-organ, occur in the deeper layers of the epidermis of man and mammals, and also in the papillæ. They consist of round or flask-shaped cells, with the lower pointed neck of the flask continuous with the axis cylinder of a nerve-fibre. They are regarded by Merkel as the simplest form of a tactile end-organ, but their existence is doubted by some observers.]

Amongst animals, there are many other forms of sensory end-organs. [Herbst's *corpuscles* occur in the mucous membrane of the tongue of the duck, and resemble small Vater's corpuscles, but their lamellæ are thinner and nearer each other, while the axis cylinder within the central core is bordered on each side by a row of nuclei.] In the nose of the mole, there is a peculiar end-organ (Eimer), while there are "*end-capsules*" in the penis of the hedgehog and the tongue of the elephant, and "*nerve-rings*" in the ears of the mouse.

5. [Other Modes of Ending of Sensory Nerves.—Some sensory nerves terminate not by means of special end-organs, but their axis cylinder splits up into fibrils to form a nervous net-work, from which fine fibrils are given off to

terminate in the tissue in which the nerve ends. These fibrils, as in the cornea (§ 384), terminate by means of free ends between the epithelium on the anterior surface of the cornea, and some observers state that the free ends are provided with small enlargements (*boutons terminals*).] A similar mode of termination occurs between the cells of the epidermis in man and mammals.

6. [**Tendons**, especially at their junction with muscles, have special end-organs (Sachs, Rollett, Golgi), which assume various forms; it may be a net-work of primitive nerve-fibrils, or flattened end-flakes or plates in the sterno-radial muscle of the frog, or elongated oval end-bulbs, not unlike the end-bulbs of the conjunctiva, or small simple Pacinian corpuscles.]

425. Sensory and Tactile Sensations.

In the sensory nerve-trunks, there are two functionally different kinds of nerve-fibres:—1, Those which administer to *painful* impressions, which are sensory nerves in the narrower sense of the word; and 2, which administer to tactile impressions, and may therefore be called *tactile* nerves. The sensations of *temperature* and *pressure* are also reckoned as belonging to the tactile group. It is extremely probable that the sensory and tactile nerves have different end-organs and fibres, and that they have also special perceptive nerve-centres in the brain, although this is not definitely proved. This view, however, is supported by the following facts:—

1. That sensory and tactile impressions cannot be discharged at the same time from all the parts which are endowed with sensibility. Tactile sensations, including pressure and temperature, are only discharged from the coverings of the skin, the mouth, the entrance to and floor of the nose, the pharynx, the lower end of the rectum and genito-urinary orifices; feeble, indistinct sensations of temperature are felt in the œsophagus. Tactile sensations are absent from all internal viscera, as has been proved in man in cases of gastric, intestinal, and urinary fistulæ. Pain alone can be discharged from these organs. 2. The conduction channels of the tactile and sensory nerves lie in different parts of the spinal cord (§ 364, 1 and 5). This renders probable the assumption, that their central and peripheral ends also are different. 3. Very probably the reflex acts discharged by both kinds of nerve-fibres—the tactile and pathic—are controlled, or even inhibited, by special central nerve-organs (§ 361—?). 4. Under pathological conditions, and under the action of narcotics, the one sensation may be suppressed, while the other is retained (§ 364, 5).

Sensory Stimuli.—In order to discharge a painful impression from sensory nerves, *relatively strong* stimuli are required. The stimuli may be mechanical, chemical, electrical, thermal, and somatic, the last being due to inflammation, or anomalies of nutrition and the like.

Peripheral Reference of the Sensations.—These nerves are excitable along their entire course, and so is their central termination, so that pain may be produced by stimulating them in any part of their course, but this pain, according to the "*law of peripheral perception*," is always referred to the periphery.

The tactile nerves can only discharge a tactile impression or sensation of contact, when moderately strong mechanical pressure is exerted, while thermal stimuli are required to produce a temperature sensation, and in both cases, the results are obtained only when the appropriate stimuli are applied to the end-organs. If pressure or cold be applied to the *course* of a nerve-trunk, *e.g.*, to the ulna at the inner surface of the elbow joint, we are conscious of painful sensations, but never of those of temperature, referable to the *peripheral* terminations of the nerves in the inner fingers. All strong stimuli disturb normal tactile sensations by over-stimulation, and hence cause pain.

426. The Sense of Locality.

We are not only able to distinguish differences of pressure or temperature by our sensory nerves, but we are able to distinguish the part which has been touched. This capacity is spoken of as the sense of space or *locality*.

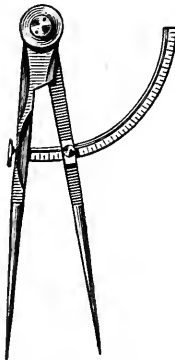

Fig. 455.
Æsthesiometer.

Methods of Testing.—Place the two blunted points of a pair of compasses at different distances upon the part of the skin to be investigated, and determine the smallest distance at which the two points are felt only as *one* impression. Sieveking's *æsthesiometer* (Fig. 456) may be used instead; one of the points is movable along a graduated rod, while the other is fixed. 2. The distance between the points of the instrument being kept the same, touch several parts of the skin, and ask if the person feels the impression of the points coming nearer to or going wider apart. 3. Touch a part of the skin with a blunt instrument, and observe if the spot touched is correctly indicated by the patient.

The investigations have led to the following results. The sense of locality of a part of the skin is more acute under the following conditions :—

1. The greater the *number of tactile nerves* in the corresponding part of the skin.
2. The greater the *mobility of the part*, so that it increases in the extremities towards the fingers and toes. The sense of locality is always very acute in parts of the body that are very rapidly moved (Vierordt)

3. The sensibility of the limbs is finer in the *transverse axis* than in the long axis of the limb, to the extent of $\frac{1}{8}$ th on the flexor surface of the upper limb, and $\frac{1}{4}$ th on the extensor surface.

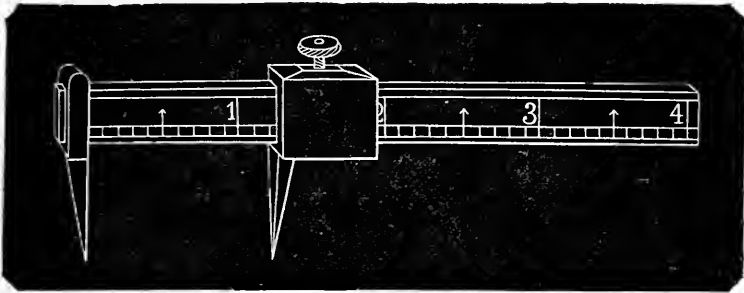

Fig. 456.

Æsthesiometer of Sieveking.

4. The *mode of application* of the points of the æsthesiometer:—(a.) According as they are applied one after the other, instead of simultaneously, or, as they are considerably warmer or colder than the skin (Klug), a person may distinguish a less distance between the points. (b.) If we begin with the points wide apart and approximate them, then we can distinguish a less distance than when we proceed from imperceptible distances to larger ones. (c.) If the one point is warm and the other cold, on exceeding the next distance, we feel two impressions, but we cannot rightly judge of their relative positions (Czermak).

5. *Exercise* greatly improves the sense of locality; hence, the extraordinary acuteness of this sense in the blind, and the improvement always occurs on both sides of the body (Volkman).

[Fr. Galton finds that the reputed increased acuteness of other senses in the case of the blind is not so great as is generally alleged. He tested a large number of boys at an educational blind asylum, with the result that the performances of the blind boys were by no means superior to those of other boys. He points out, however, that "the guidance of the blind depends mainly on the multitude of collateral indications, to which they give much heed, and not in their superiority to any one of them."]

6. *Moistening* the skin with indifferent fluids increases the acuteness. If, however, the skin between two points, which are still felt as two distinct objects, be slightly tickled, or be traversed by an imperceptible electrical current, the impressions become fused (Suslowa). The sense of locality is rendered more acute at the cathode when a constant current is used (Suslowa), and when the skin is congested by stimulation (Klinkenberg), and also by slight stretching of the skin (Schmey); further, by baths of carbonic acid (v. Basch and v. Dietl), or warm common salt, and temporarily by the use of caffeine (Rumpf).

7. *Anæmia*, produced by elevating the limbs, or *venous hyperæmia* (by compressing the veins), blunts the sense, and so does too frequent testing of the sense of locality, by producing fatigue. The sense is also blunted by cold applied to the skin, the influence of the anode, strong stretching of the skin, as over the abdomen during pregnancy, previous exertion of the muscles under the part of the skin tested, and some poisons, *e.g.*, atropin, daturin, morphin, strychnin, alcohol, potassium bromide, cannabin, and chloral hydrate.

Smallest Appreciable Distance.—The following statement gives the smallest distance in *millimetres*, at which two points of a pair of compasses can still be distinguished as double by an adult. The corresponding numbers for a boy twelve years of age are given within brackets:—

	Millimetres.		Millimetres.
Tip of tongue,	1·1 [1·1]	Eyelid,	11·3 [9]
Third phalanx of finger, volar surface,	2·2-2·3 [1·7]	Centre of hard palate,	13·5 [11·3]
Red part of the lip,	4·5 [3·9]	Lower third of the fore-arm, volar surface,	15·
Second phalanx of finger, volar surface,	4·4-4·5 [3·9]	In front of the zygoma,	15·8 [11·3]
First phalanx of finger, volar surface,	5·5-5·5	Plantar surface of the great toe,	15·8 [9·]
Third phalanx of finger, dorsal surface,	6·8 [4·5]	Inner surface of the lip,	20·3 [13·5]
Tip of nose,	6·8 [4·5]	Behind the zygoma,	22·6 [18·]
Head of metacarpal bone, volar,	5·6-6·8 [4·5]	Forehead,	22·6 [18·]
Ball of thumb,	6·5-7·	Occiput,	27·1 [22·6]
Ball of little finger,	5·5-6·	Back of the hand,	31·6 [22·6]
Centre of palm,	8·-9·	Under the chin,	33·8 [22·6]
Dorsum and side of tongue, white of the lips, metacarpal part of the thumb,	9· [6·8]	Vertex,	33·8 [22·6]
Third phalanx of the great toe, plantar surface,	11·3 [6·8]	Knee,	36·1 [31·6]
Second phalanx of the fingers, dorsal surface,	11·3 [9·]	Sacrum, gluteal region,	44·6 [33·8]
Back,	11·3 [9·]	Fore-arm and leg,	45·1 [33·8]
		Neck,	54·1 [36·1]
		Back at the fifth dorsal vertebra, lower dorsal and lumbar region,	54·1
		Middle of the neck,	67·7
		Upper arm, thigh, and centre of the back,	67·7 [31·6-40·6]

Illusions of the sense of locality occur very frequently; the most marked are:—1. A uniform movement over a cutaneous surface appears to be quicker in those places which have the finest sense of locality. 2. If we merely *touch* the skin with the two points of an æsthesiometer, then they feel as if they were wider apart than when the two points are *moved along* the skin (Fechner). 3. A sphere, when touched with short rods, feels larger than when long rods are used (Tourtual). 4. When the fingers of one hand are crossed, a small pebble or sphere placed between them feels double (*Aristotle's experiment*). [When a pebble is rolled between the crossed index and middle finger (Fig. 457, B), it feels as if two balls were present, but with the fingers uncrossed single.] 5. When pieces of skin are transplanted—*e.g.*, from the forehead to form a nose, the person operated on feels, often for a long time, the new nasal part as if it were his forehead.

Theoretical.—Numerous experiments were made by E. H. Weber, Lotze, Meissner, Czermak, and others, to explain the phenomena of the sense of space.

Weber's theory goes upon the assumption, that one and the same nerve-fibre proceeding from the brain to the skin can only take up one kind of impression, and administer thereto. He called the part of the skin to which each single nerve-

fibre is distributed a "circle of sensation." When two stimuli act simultaneously upon the tactile end-organ, then a double sensation is felt, when one or more circles of sensation lie between the two points stimulated. This explanation, based upon anatomical considerations, does not explain how it is that, with practice, the circles of sensation become smaller, and also how it is that only *one* sensation occurs, when both points of the instrument are so applied, that both points, although further apart than the diameter of a circle of sensation, at one time lie upon two adjoining circles, at another between two others with another circle intercalated between them.

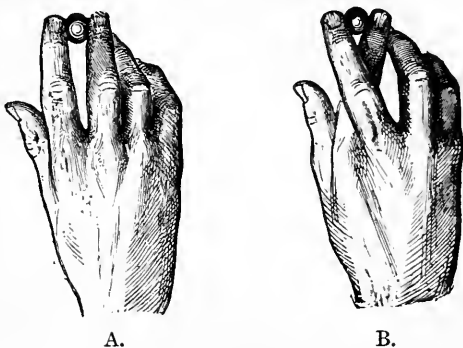

A. Fig. 457. B.
Aristotle's experiment (Knott).

Wundt's Theory.—In accordance with the conclusions of Lotze, Wundt proceeds from a psycho-physiological basis, that every part of the skin with tactile sensibility always conveys to the brain the *locality* of the sensation. Every cutaneous area, therefore, gives to the tactile sensation a "*local colour*" or quality, which is spoken of as the "*local sign*." He assumes that this local colour diminishes from point to point of the skin. This gradation is very sudden in those parts of the skin where the sense of space is very acute, but occurs very gradually where the sense of space is more obtuse. Separate impressions unite into a common one, as soon as the gradation of the local colour becomes imperceptible. By practice and attention differences of sensation are experienced, which ordinarily are not observed, so that he explains the diminution of the circles of sensation by practice. The circle of sensation is an area of the skin, within which the local colour of the sensation changes so little, that two separate impressions fuse into *one*.

427. The Pressure Sense.

By the sense of pressure we obtain a knowledge of the amount of weight or pressure which is being exercised at the time on the different parts of the skin.

Methods.—1. Place, on the part of the skin to be investigated, different weights one after the other, and ascertain what perceptions they give rise to, and the sense of the difference of pressure to which they give rise. We must be careful to exclude differences of temperature and prevent the displacement of the weights—the weights must always be placed on the same spot, and the skin should be covered beforehand with a plate, while the muscular sense must be eliminated (§ 430). [This is done by supporting the hand or part of the skin

which is being tested, so that the action of all the muscles is excluded.] 2. A process is attached to a balance and made to touch the skin, while by placing weights in the scale-pan or removing them, we test what differences in weight the person experimented on is able to distinguish (Dohrn). 3. In order to avoid the necessity of changing the weights, A. Eulenberg invented his **baræsthesiometer**, which is constructed on the same principle as a spiral spring paper-clip or balance. There is a small button which rests on the skin and is depressed by the spring. An index shows at once the pressure in grammes, and the instrument is so arranged that the pressure can be very easily varied. 4. Goltz uses a *pulsating, elastic tube*, in which he can produce waves of different height. He tested how high the latter must be before they are experienced as pulse-waves, when the tube is placed upon the skin. 5. Landois uses a **mercurial balance** (Fig. 458). The beam of a balance (W) moves upon two knife-edges (O, O), and is carried on the horizontal arm (b) of a heavy support (T). One arm of the beam is provided with a screw (m) on which an equilibrating weight (S) can be moved. The other arm (d) passes into a vertical, calibrated tube (R). Below this is the pressure-pad (P), which can be loaded as desired by a weight (G), and which can be placed upon the part of the skin to be tested (H). From an adjoining burette (B) held in a

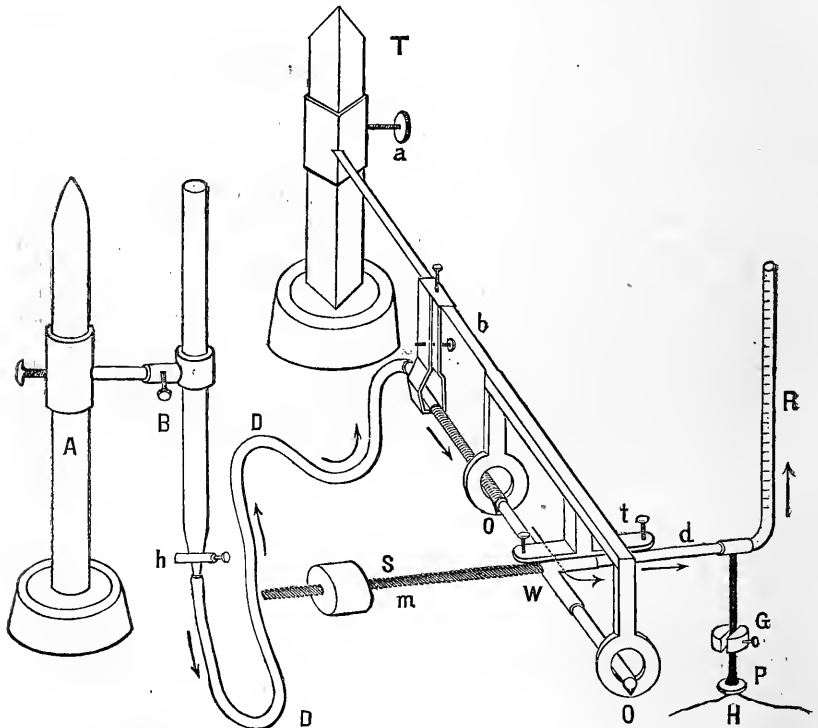

Fig. 458.

Landois' mercurial balance for testing the pressure sense.

clamp (A), mercury can pass through a tube in the direction of the arrows, to one part of the balance and into the tube (R). On the stop-cock (h) being closed, whenever pressure is exerted on the tube (D, D), the mercury rises through d into

R, and increases the pressure on P. We measure the weight of the mercury corresponding to each division of the tube (R). This instrument enables rapid variations of the weight to be made without giving rise to any shock. In estimating both the pressure sense and temperature sense, it is best to proceed on the principle of "the least perceptible difference," *i.e.*, the different pressures or temperatures are graduated, either beginning with *great* differences, or proceeding from the *smallest* difference, and determining the limit at which the person can distinguish a difference in the sensation.

Results.—1. The *smallest perceptible pressure*, when applied to different parts of the skin, varies very greatly according to the locality. The greatest acuteness of sensibility is on the forehead, temples, and the back of the hand and fore-arm, which perceive a pressure of 0.002 gm.; the fingers first feel with a weight of 0.005–0.015 gm.; the chin, abdomen, and nose with 0.04–0.05 gm.; the finger nail 1 gm. (Kammler and Aubert).

The greater the sensibility of the skin, the more rapidly can single stimuli succeed each other, and still be perceived as single impressions; 52 stimuli per second may be applied to the volar side of the upper arm, 61 on the back of the hand, 70 to the tips of the fingers, and still be felt singly (Bloch).

2. Intermittent variations of pressure, as in Goltz's tube, are felt more acutely by the tips of the fingers than with the forehead.

3. Differences between two weights are perceived by the tips of the fingers when the ratio is 29:30 (in the fore-arm as 18.2:20), provided the weights are not too light or too heavy. In passing from the use of very light to heavy weights, the acuteness or fineness of the perception of difference increases at once, but with heavier weights, the power of distinguishing differences rapidly diminishes again (E. Hering, Lœwit, and Biedermann). This observation is at variance with the psychophysical law of Fechner (§ 383).

4. A. Eulenburg found the following gradations in the fineness of the pressure sense:—The forehead, lips, dorsum of the cheeks and temples appreciate differences of $\frac{1}{40}$ to $\frac{1}{30}$ (200:205–300:310 gm.). The dorsal surface of the last phalanx of the fingers, the fore-arm, hand, 1st and 2nd phalanx, the volar surface of the hand, fore-arm, and upper arm distinguish differences of $\frac{1}{10}$ to $\frac{1}{20}$ (200:220 to 200:210 gm.). The anterior surface of the leg and thigh are similar to the fore-arm. Then follow the dorsum of the foot and toes, the sole of the foot and the posterior surface of the leg and thigh. Dohrn determined the smallest additional weight, which when added to 1 gm. already resting on the skin was appreciated as a difference, and he found that for the 3rd phalanx of the finger it was .499 gm.; back of the foot, 0.5 gm.; 2nd phalanx, 0.771 gm.; 1st phalanx, 0.82 gm.; leg, 1 gm.; back of the hand, 1.156 gm.; palm, 1.018 gm.; patella, 1.5 gm.; fore-arm, 1.99 gm.; umbilicus, 3.5 grms.; and the back, 3.8 grms.

5. Too long time must not elapse between the application of two successive weights, but 100 seconds may elapse when the difference between the weights is 4 : 5 (E. H. Weber).

6. The sensation of an *after pressure* is very marked, especially if the weight is considerable and has been applied for a length of time. But even light weights, when applied, must be separated by an interval of at least $\frac{1}{480}$ to $\frac{1}{110}$ second, in order to be perceived. When they are applied at shorter intervals, the sensations become fused. When Valentin pressed the tips of his fingers against a wheel provided with blunt teeth, he felt the impressiom of a *smooth* margin, when the teeth were applied to the skin at the intervals above mentioned; when the wheel was rotated more slowly, each tooth gave rise to a distinct impression. Vibrations of strings are distinguished as such, when the number of vibrations is 1506–1552 per second (v. Wittich and Grünhagen).

7. It is remarkable that pressure produced by the uniform compression of a part of the body, *e.g.*, by dipping a finger or arm in mercury, is not felt as such; the sensation is felt only at *the limit of the fluid*, on the volar surface of the finger, at the limit of the surface of the mercury.

428. The Temperature Sense.

The temperature sense makes us acquainted with the variations of the heat of the skin. The circumstance determining the sensation of temperature is, according to E. Hering, the temperature of the thermal end-organs themselves. As often as any part of the skin has a temperature *above* its zero, *i.e.*, its neutral proper temperature, we feel warm; in the opposite condition we feel cold. The one or the other sensation, becomes stronger, the more the temperature of the thermal end-organ differs from its zero temperature. The zero temperature, however, may vary pretty rapidly, from external causes, within certain limits.

Methods.—To the surface of the skin objects of the same size and with the same thermal conductivity, are applied successively at different temperatures:—1, Nothnagel uses small wooden cups with a metallic base, and filled with warm and cold water, the temperature being registered by a thermometer placed in the cups. [2, Clinically, two test-tubes, filled with cold and warm water, or two spoons, the one hot and the other cold, may be used.]

Results.—1. As a general rule, the feeling of cold is produced when a body applied to the skin robs it of heat; and, conversely, we have a sensation of warmth, when heat is communicated to the skin.

2. The greater the thermal conductivity of the substance touching the skin, the more intense is the feeling of heat or cold (§ 218).

3. At a temperature of 15.5–35°C., we distinguish distinctly differences of temperature of 0.2–0.16°R. with the tips of the fingers (E. H. Weber). Temperatures just below that of the blood (33°–27°C.—Nothnagel) are distinguished most distinctly by the most sensitive parts, even to differences of 0.05°C. (Lindemann). Differences of temperature are less easily made out, when dealing with temperatures of 33°–39°C., as well as between 14°–27°C. A temperature of 55°C., and also one a few degrees above zero, cause distinct pain in addition to the sensation of temperature.

4. The different parts of the skin also vary in the acuteness of their thermal sense, and in the following order:—Tip of the tongue, eyelids, cheeks, lips, neck, and body. The perceptible minimum Nothnagel found to be 0.4° on the breast; 0.9° on the back; 0.3°, back of the hand; 0.4°, palm; 0.2°, arm; 0.4°, back of the foot; 0.5°, thigh; 0.6°, leg; 0.4°–0.2°, cheek; 0.4°–0.3°C., temple. The thermal sense is less acute in the middle line (*e.g.*, the nose) than on each side of it (E. H. Weber).

5. Differences of temperature are most easily perceived when the same part of the skin is affected successively by objects of different temperature. If, however, two different temperatures act simultaneously and side by side, the impressions are apt to become fused, especially when the two areas are very near each other.

6. Practice improves the temperature sense; congestion of venous blood in the skin diminishes it; diminution of the amount of blood in the skin improves it (M. Alsberg). When *large* areas of the skin are touched, the perception of differences is more acute than with small areas. Rapid variations of the temperature produce more intense sensations than gradual changes of temperature.

Illusions are very common:—1. The sensations of heat and cold sometimes alternate in a paradoxical manner. When the skin is dipped first into water at 10°C. we feel cold, and if it be then dipped at once into water at 16°C. we have at first a feeling of warmth, but soon again of cold. 2. The same temperature applied to a large surface of the skin is estimated to be greater than when it is applied to a small area—*e.g.*, the whole hand when placed in water at 29.5°C. feels warmer than when a finger is dipped into water at 32°C. 3. Cold weights are judged to be heavier than warm ones.

Pathological.—Tactile sensibility is only seldom *increased* (**hyperpæsthesia**), but great sensibility to differences of temperature is manifested by areas of the skin whose epidermis is partly removed or altered by vesicants or herpes zoster, and the same occurs in some cases of locomotor ataxia; while the sense of locality is rendered more acute in the two former cases and in erysipelas. An abnormal condition of the sense of locality was described by Brown-Séquard, where three points were felt when only two were applied, and two when one was applied to the skin. Landois finds that in himself pricking the skin of the sternum over the angle of Ludovicus is always accompanied by a sensation in the knee. [Some persons, when cold water is applied to the scalp, have a pain referable to the skin of the loins (Stirling).] A remarkable variation of the sense

of locality occurs in moderate poisoning with morphia, where the person feels himself abnormally large or greatly diminished. In degeneration of the posterior columns of the cord, Obersteiner observed that the patient was unable to say whether his right or left side was touched ("*Allochiria*"). Ferrier observed a case where a stimulus applied to the right side was referred to the left, and *vice versa*.

Diminution and paralysis of the tactile sense (*Hypopselaphesia* and *Apselaphesia*) occur either in conjunction with simultaneous injury to the sensory nerves, or alone. It is rare to find that one of the qualities of the tactile sense is lost, *e.g.*, either the tactile sense or the sense of temperature—a condition which has been called "*partial tactile paralysis*." Limbs which are "*sleeping*" feel heat and not cold (Herzen).

429. Common Sensation—Pain.

Definition.—By the term common sensation we understand pleasant or unpleasant sensations in those parts of our bodies which are endowed with sensibility, and which are not referable to external objects, and whose characters are difficult to describe, and cannot be compared with other sensations. Each sensation is, as it were, a peculiar one. To this belong pain, hunger, thirst, malaise, fatigue, horror, vertigo, tickling, well-being, illness, the respiratory feeling of free or impeded respiration.

Pain may occur wherever sensory nerves are distributed, and it is invariably caused by a stronger stimulus than normal being applied to sensory nerves. Every kind of stimulation, mechanical, thermal, chemical, electrical, as well as somatic (inflammation or disturbances of nutrition) may excite pain. The last appear to be especially active, as many tissues become extremely painful during inflammation (*e.g.*, muscles and bones), while they are comparatively insensible to cutting. Pain may be produced by stimulating a sensory nerve in any part of its course, from its centre to the periphery, but the sensation is invariably referred to the peripheral end of the nerve. This is the law of the peripheral reference of sensations. Hence, stimulation of a nerve, as in the scar of an amputated limb, may give rise to a sensation of pain which is referred to the parts already removed. Too violent stimulation of a sensory nerve in its course may render it incapable of conducting impressions, so that peripheral impressions are no longer perceived. If a sufficient stimulus to produce pain be now applied to the central part of the nerve, such an impression is still referred to the peripheral end of the nerve. Thus we explain the paradoxical *anæsthesia dolorosa*. In connection with painful impressions, the patient is often unable to localise them exactly. This is most easily done when a small injury (prick of a needle) is made on a peripheral part. When, however, the stimulation occurs in the course of the

nerve, or in the centre, or in nerves whose peripheral ends are not accessible, as in the intestines, pain (as belly-ache), which cannot easily be localised, is the result.

Irradiation.—During violent pain there is not unfrequently irradiation of the pain (§ 364, 5), whereby localisation is impossible. It is rare for pain to remain continuous and uniform; more generally there are exacerbations and diminutions of the intensity, and sometimes *periodic* intensification.

The intensity of the pain depends especially upon the excitability of the sensory nerves. There are considerable individual variations in this respect, some nerves—*e.g.*, the trigeminus and splanchnic—being very sensitive. The larger the number of fibres affected, the more severe the pain. The duration is also of importance, in as far as the same stimulation, when long continued, may become unbearable. We speak of piercing, cutting, boring, burning, throbbing, pressing, gnawing, dull, and other kinds of pain, but we are quite unacquainted with the conditions on which such different sensations depend. Painful impressions are abolished by *anæsthetics* and *narcotics*, such as ether, chloroform, morphia, etc. (§ 364, 5).

Methods of Testing.—To test the cutaneous sensibility, we usually employ the constant or induced electrical current. Determine first the *minimum sensibility*, *i.e.*, the strength of the current which excites the first trace of sensation, and also the *minimum of pain*, *i.e.*, the feeblest strength of the current which first causes distinct impressions of pain. The electrodes consist of thin metallic needles, and are placed 1–2 cm. apart (Fig. 312).

Pathological.—When the excitability of the nerves which administer to painful sensations is increased, a slight touch of the skin, nay, even a breath of cold air, may excite the most violent pain, constituting **cutaneous hyperalgia**, especially in inflammatory or exanthematic conditions of the skin. The term **cutaneous paralgia** is applied to certain anomalous, disagreeable, or painful sensations which are frequently referred to the skin—itching, creeping, formication, cold, and burning. In cerebro-spinal meningitis, sometimes a prick in the sole of the foot produces a double sensation of pain and a double reflex contraction. Perhaps this condition may be explained by supposing that in a part of the nerve the conduction is delayed (§ 337, 2). In **neuralgia** there is severe pain occurring in paroxysms, with violent exacerbations and pain shooting into other parts (p. 802). Very frequently excessive pain is produced by pressure on the nerve where it makes its exit from a foramen or traverses a fascia.

Valleix's Points Dououreux (1841).—The skin itself to which the sensory nerve runs, especially at first, may be very sensitive; and when the neuralgia is of long duration, the sensibility may be diminished even to the condition of analgesia (Türk); in the latter case, there may be pronounced *anæsthesia dolorosa* (p. 1096).

Diminution or paralysis of the sense of pain (**hypalgia** and **analgia**) may be due to affections of the ends of the nerves, or of their course, or central terminations.

Metalloscopy.—In hysterical patients suffering from hemianæsthesia, it is found that, the feeling of the paralysed side is restored, when small metallic plates or larger pieces of different metals are applied to the affected parts (Burcq,

Charcot). At the same time that the affected part recovers its sensibility, the opposite limb or side becomes anæsthetic. This condition has been spoken of as transference of sensibility. The phenomenon is not due to galvanic currents developed by the metals. The phenomenon is perhaps explained by the fact that, under physiological conditions, and in a healthy person, every increase of the sensibility on one side of the body, produced by the application of warm metallic plates or bandages, is followed by a diminution of the sensibility of the opposite side. Conversely, it is found that when one side of the body is rendered less sensitive by the application of cold plates, the homologous part of the other side becomes more sensitive (Rumpf and M. Rosenthal).

430. The Muscular Sense.

Muscular Sensibility.—The sensory nerves of the muscles (§ 292) always convey to us impressions as to the activity or non-activity of these organs, and, in the former case, these impressions enable us to judge of the degree of contraction. It also informs us of the amount of the contraction to be employed to overcome resistance. Obviously, the muscular sense must be largely supported and aided by the sense of pressure, and conversely. E. H. Weber showed, however, that the muscle sense is finer than the pressure sense, as by it we can distinguish weights in the ratio of 39 : 40, while the pressure sense only enables us to distinguish those in the ratio of 29 : 30. In some cases, there has been observed total cutaneous insensibility, while the muscular sense was retained completely. A frog deprived of its skin can spring without any apparent disturbance. The muscular sense is also greatly aided by the sensibility of the joints, bones, and fasciæ. Many muscles—*e.g.*, those of respiration—have only slight muscular sensibility, while it seems to be absent normally in the heart and non-striated muscle.

[The muscular sense stands midway between special and common sensations, and by it we obtain a knowledge of the condition of our muscles, and to what extent they are contracted; also the position of the various parts of our bodies, and the resistance offered by external bodies. Thus, sensations accompanying muscular movement are twofold—(*a*) the movements in the unopposed muscles, as the movements of the limbs in space; and (*b*) those of resistance, where there is opposition to the movement, as in lifting a weight. In the latter case, the sensations due to innervation are important, and, of course, in such cases we have also to take into account the sensations obtained from mere pressure upon the skin. Our sensations derived from muscular movements depend on the *direction and duration* of the movements. On the sensations thus conveyed to the sensorium, we form judgments as to the direction of a point in space, as well as of the distance between two points in space. This is very marked in the case of the

ocular muscles. It is also evident that the muscular sense is ultimately related to, and often combined with, the exercise of the sensations of touch and sight (Sully).]

Methods of Testing.—Weights are wrapped in a towel and suspended to the part to be tested. The patient estimates the weight by raising and lowering it. The *electro-muscular sensibility* also may be proved thus; cause the muscles to contract by means of induction shocks, and observe the sensation thereby produced. [Direct the patient to place his feet together while standing, and then close his eyes. A healthy person can stand quite steady, but in one with the muscular sense impaired, as in locomotor ataxia, the patient may move to and fro, or even fall. Again, a person with his muscular sense impaired may not be able to touch accurately and at once some part of his body, when his eyes are closed.]

Section of a sensory nerve causes disturbance of the fine gradation of movement (p. 828). Meynert supposes that the cerebral centre for muscular sensibility lies in the motor cortical centres, the muscles being connected by motor and sensory paths with the ganglionic cells in these centres.

Too severe muscular exercise causes the sensation of *fatigue*, *oppression*, and *weight* in the limbs.

Pathological.—Abnormal increase of the muscular sense is rare (*muscular hyperlagia* and *hyperæsthesia*); as in *anxietas tibiærum*, a painful condition of unrest, which leads to a continual change in the position of the limbs. In **cramp** there is intense pain, due to stimulation of the sensory nerves of the muscle, and the same is the case in inflammation. *Diminution* of the muscular sensibility occurs in some choreic and ataxic persons (§ 364, 5). In locomotor ataxia the muscular sense of the upper extremities may be normal or weakened, while it is usually considerably diminished in the legs. [The muscular sense is said to be increased in the hypnotic condition, and in somnambulists.]

Physiology of Reproduction and Development.

431. Forms of Reproduction.

I. Abiogenesis (*Generatio aequivoca, sive spontanea, spontaneous generation*).

—It was formerly assumed that, under certain circumstances, non-living matter derived from the decomposition of organic materials became changed spontaneously into living beings. While Aristotle ascribed this mode of origin to insects, the recent observers, who advocate this form of generation, restrict its action solely to the lowest organisms. Experimental evidence is distinctly against spontaneous generation. If organised matter be heated to a very high temperature in sealed tubes, and be thus deprived of all living organisms or their spores, there is no generation of any organism. Hence, the dictum, “*Omne vivum ex ovo*” (Harvey, or *ex vivo*). Some highly organised invertebrate animals (*Gordius, Anguillula, Tardigrada, and Rotatoria*) may be dried, and even heated to 140°C., and yet regain their vital activities on being moistened (*Anabiosis*).

II. **Division or fission** occurs in many protozoa (*ameba, infusoria*). The organism, just as is the case with cells, divides, the nucleus, when present taking an active part in the process, so that two nuclei and two masses of protoplasm forming two organisms are produced. The *Ophidiasters* amongst the echinoderms divide spontaneously, and they are said to throw off an arm which may develop into a complete animal. According to Trembley (1744), the hydra may be divided into pieces, and each piece gives rise to a new individual, [although under normal circumstances the hydra gives off buds, and is provided with generative organs].

[**Division of Cells.**—Although a cell is defined as a “nucleated mass of protoplasm,” recent researches have shown that, from a histological point of

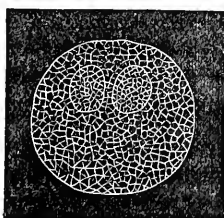

Fig. 459.

Intra-cellular and intra-nuclear plexus of fibrils of a white blood-corpuscle with two nuclei (Knott, after Klein and Noble-Smith).



Fig. 460.

Changes in a cell nucleus during karyokinesis.

view, a cell is really a very complex structure. The apparently homogeneous cell-substance is traversed by a fine plexus of fibrils, with a homogeneous substance in its meshes, while a similar net-work of fibrils exists within the nucleus itself (Fig. 459). A cell may divide *directly*, as it were, by simple cleavage, and in the process the nucleus usually divides before the cell protoplasm. The nucleus becomes constricted in the centre, has an hour-glass shape, and soon divides into two. But recent observations, confirmed by a great number of investigators, conclusively prove that the process of division in cells is a very complicated one, the changes in the nucleus being very remarkable. The term **karyokinesis**, or *indirect division*, has been applied to this process. Fig. 460 shows the changes that take place in the nucleus. The intranuclear net-work (*a*) passes into a *convolution* of thinner fibrils, while the nuclear envelope becomes less distinct, the fibrils at the same time becoming thicker and forming loops, which gradually arrange themselves around a centre (*c* and *d*) in the form of a *wreath* or *rosette*. The fibres curve round both at the periphery and the centre; but when their peripheral connections are severed or dissolved, we obtain a star-shaped form or *aster*, composed of single loops radiating from the centre (*e*). After further subdivision, the whole is composed of fine, radiating fibrils (*f*), which gradually arrange themselves around two poles, or new centres, to form a *diaster*, or double star (*g*), the two groups being separated by a substance called the *equatorial plate*. Each of the groups of fibrils becomes more elongated, and forms a nuclear spindle, which indicates the position of a new nucleus. The separate groups of fibrils again become convoluted, each group gets a nuclear membrane, while the cell protoplasm divides, and two *daughter nuclei* are obtained from the original cell.]

III. **Budding or gemmation** occurs in a well-marked form amongst the polyps and in some infusorians (Vorticella). A bud is given off by the parent, and gradually comes more and more to resemble the latter. The bud either remains permanently attached to the parent, so that a complex organism is produced, in which the digestive organs communicate with each other directly, or in some cases there may be a "colony" with a common nervous system, such as the polyzoa. In some composite animals (siphonophora), the different polyps perform different functions. Some have a digestive, others a motor, and a third a generative function, so that there is a physiological division of labour. Buds which are given off from the parent are formed internally in the rhizopoda. In some animals (polyps, infusoria), which can reproduce themselves by buds or division, there is also the formation of male and female elements of generation, so that they have a sexual and a non-sexual mode of reproduction.

IV. **Conjugation** is a form of reproduction which leads up to the sexual form. It occurs in the unicellular Gregarina. The anterior end of one such organism unites with the posterior end of another; both become encysted, and form one passive spherical body. The conjoined structures form an amorphous mass, from which numerous globular bodies are formed, and in each of which numerous oblong structures—the pseudonavicelli—are developed. These bodies become, or give rise to, an amœboid structure, which forms a nucleus and an envelope, and becomes transformed into a gregarina.

Sexual reproduction requires the formation of the embryo from the conjunction of the male and female reproductive elements—the *sperm cell* and the *germ cell*. These products may be formed either in one individual (hermaphroditism, as in the flat worms and gasteropods), or in two separate organisms (male or female). Sexual reproduction embraces the following varieties:—

V. **Metamorphosis** is that form of sexual reproduction in which the embryo from an early period undergoes a series of marked changes of external form, *e.g.*, the chrysalis stage, and the pupa stage, and in none of these stages is reproduction possible. Lastly, the final sexually developed form (the imago stage in butterflies),

is produced, which forms the sexual products whose union gives rise to organisms which repeat the same cycle of changes. Metamorphosis occurs extensively amongst the insects; some of them have several stages (holo-metabolic), and others have few stages (hemi-metabolic). It also occurs in some arthropoda, and worms, e.g., trichina; the sexual form of the animal occurs in the intestine, the numerous *larvæ* wander into the muscles, where they become encysted, and form undeveloped sexual organs, constituting the pupa stage of the muscular trichina. When the encysted form is eaten by another animal, the sexual organs come into activity, a new brood is formed, and the cycle is repeated. Metamorphosis also occurs in the frog and in petromyzon. [This is really a condition in which the embryo undergoes marked changes of form before it becomes sexually mature.]

VI. Alternation of Generations (Steenstrup).—In this variety, some of the members of the cycle can produce new beings non-sexually, while in the final stage, reproduction is always sexual. From a medical point of view, the life-history of the tape-worm, *Tænia*, is most important. The segments of the tape-worm are called *proglottides*, and each segment is hermaphrodite, with testes, vas deferens, penis, ovary, &c., and numerous ova. The segments are evacuated with the fæces. The eggs are fertilised after they are shed, and from them is developed an elliptical *embryo*, provided with six hooklets, which is swallowed by another animal, the host. These embryos bore their way into the tissues of the host, where they undergo development, forming the encysted stage (cysticercus, coenurus, or echinococcus). The encysted capsule may contain one (cysticercus) or many (coenurus) sessile heads of the *tænia*. In order to undergo further development, the cysticercus must be eaten alive by another animal, when the head or *scolex* fixes itself by its hooklets and suckers to the intestine of its new host, where it begins to bud and produce a series of new segments between the head and the last-formed segment, and thus the cycle is repeated.

The most important flat-worms are:—*Tænia solium*, in man; the *Cysticercus cellulosæ*, in the pig, where it constitutes the *measle* in pork; *Tænia mediocanellata*, the encysted stage in the ox; *Tænia coenurus*, in the dog's intestine; the encysted stage, or *Coenurus cerebralis*, in the brain of the sheep, where it gives rise to the condition of "staggers;" *Tænia echinococcus*, in the dog's intestine; the embryos or scolices occur in the liver of man as "hydatids."

The medusæ also exhibit alternation of generations, and so do some insects, especially the plant lice or aphides.

VII. Parthenogenesis (Owen, v. Siebold).—In this variety, in addition to sexual reproduction, new individuals may be produced without sexual union. The non-sexually produced brood is always of one sex, as in the bees. A bee-hive contains a queen, the workers, and the drones or males. During the nuptial flight the queen is impregnated by the males, and the seminal fluid is stored up in the receptaculum seminis of the queen, and it appears that the queen may voluntarily permit the contact of this fluid with the ova or withhold it. All fertilised eggs give rise to female, and all unfertilised ones to male bees.

VIII. Sexual reproduction without any intermediate stages occurs in, besides man, mammals, birds, reptiles, and most fishes.

432. Seminal Fluid.

Chemical Composition.—The seminal fluid, as discharged from the urethra, is mixed with the secretion of the glands of the vas deferens,

Cowper's glands and those of the prostate, and with the fluid of the vesiculæ seminales. Its *reaction* is neutral or alkaline, and it contains 82 per cent. of water, serum-albumin, alkali-albuminate, nuclein, lecithin, cholesterin, fats (protamin?), phosphorised fat, salts (2 per cent.), especially phosphates of the alkalis and earths, together with sulphates, carbonates, and chlorides. The odorous body, whose nature is unknown, was called "*spermatin*" by Vanquelin.



Fig. 461.

Crystals from spermatic fluid.

Seminal Fluid.—The sticky, whitish-yellow seminal fluid, largely composed of a mixture of the secretions of the above-named glands, when exposed to the air, becomes more fluid, and on adding water it becomes gelatinous, and from it separates whitish, transparent flakes. When long exposed, it forms rhomboidal crystals, which, according to Schreiner, consist of phosphatic salts with an organic base (C_2H_5N). These crystals (Fig. 461) are said to be derived from the prostatic fluid, and are identical with the so-called Charcot's crystals (Fig. 115, c, and § 138, p. 275). The prostatic fluid is thin, milky, amphoteric, or of slightly acid reaction, and is possessed of the seminal odour. The phosphoric acid necessary for the formation of the crystals is obtained from the seminal fluid. A somewhat similar odour occurs in the albumin of eggs not quite fresh. The secretion of the vesiculæ seminales of the guinea-pig contains much fibrinogen (Hensen and Landwehr).

The **spermatozoa** are 50μ long, and consist of a flattened pear-shaped *head* (Fig. 462, 1 and 2, *k*), which is followed by a rod-shaped *middle piece*, *m* (Schweigger-Seidel) and a long tail-like prolongation or *cilium*, *f*. The whole spermatozoon is propelled forwards by the to-and-fro movements of the tail, at the rate of 0.05 – 0.5 mm. per second; the movement is most rapid immediately after the fluid is shed, but it gradually becomes feebler.

G. Retzius describes a special terminal filament (Fig. 462, *e*). An axial thread, surrounded by an envelope of protoplasm, traverses the middle piece and the tail (Eimer, v. Braun).

Finer Structure.—The observations of Jensen have shown that the middle piece and head are still more complex, although this is not the case in human spermatozoa and those of the bull (G. Retzius). These consist of a flattened, long, narrow, transparent, protoplasmic mass, with a fibre composed of many delicate threads in both margins. At the tip of the tail both fibres unite into one. The fibre of the one margin is generally straight; the other is thrown into wave-like folds, or winds in a spiral manner round the other (W. Krause, Gibbes). [Leydig

showed that in the salamander there is a delicate membrane attached to the tail, and Gibbes has described a spiral thread attached to the head (newt) and connected with the middle piece by a hyaline membrane.]

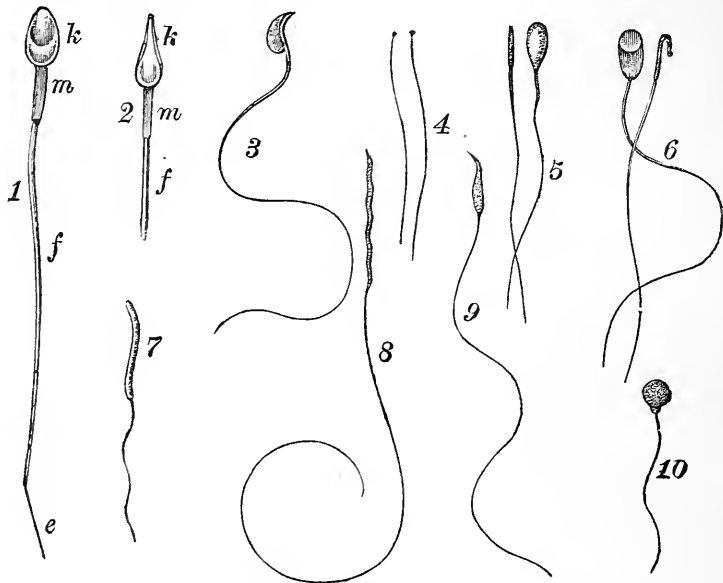

Fig. 462.

Spermatozoa—1, human ($\times 600$), the head seen from the side; 2, seen on edge; *k*, head; *m*, middle piece; *f*, tail; *e*, terminal filament (Retzius); 3, from the mouse; 4, *bothriocephalus latius*; 5, deer; 6, mole; 7, green woodpecker; 8, black swan; 9, from a cross between a goldfinch (M) and a canary (F); 10, from *cobitis* (A. Ecker).

Motion of the Spermatozoa.—[After the discharge of the seminal fluid, the spermatozoa exhibit spontaneous movements for many hours or days.] The movements are due to the lashing movements of the tail, which moves in a circle or rotates on its long axis, the impulse to movement proceeding from the protoplasm of the middle piece and the tail, which seem to be capable of moving when they are detached (Eimer). These movements are comparable to those that occur in cilia (§ 292), and there are transition forms between ciliary and amoeboid movements, as in the Monera. Within the testis they do not exhibit movement, as the fluid is not sufficiently dilute to permit them to move. Their movements are specially lively in the normal secretion of the female sexual organs (Bischoff), and they move pretty freely, and for a long time, in all normal animal secretions except saliva. Their movements are paralysed by water, alcohol, ether, chloroform, creosote, gum, dextrin, vegetable mucin, syrup of grape-sugar, or very alkaline or acid uterine or vaginal mucus (Donné), acids and metallic salts, and a too high or too low temperature. The narcotics, as long as they are chemically indifferent, behave as indifferent fluids, and so do medium solutions of urea, sugar, albumin, common salt, glycerin, amygdalin, &c.; but if these be too dilute or too concentrated, they alter the amount of water in the spermatozoa and paralyse them. The quiescence produced by water may be set aside by dilute alkalis (Virchow), as with cilia (p. 613). Engelmann finds that minute traces of acids, alcohol, and

ether excite movements. The spermatozoa of the frog may be frozen four times in succession without killing them. They bear a heat of 43.75°C ., and they will live for 70 days when placed in the abdominal cavity of another frog (Mantegazza).

Resistance.—Owing to the large amount of earthy salts which they contain, when dried upon a microscopical slide, they still retain their form (Valentin). Their form is not destroyed by nitric, sulphuric, hydrochloric, or boiling acetic acid, or by caustic alkalies; solutions of NaCl and saltpetre (10-15 per cent.) change them into amorphous masses. Their organic basis resembles the semi-solid albumin of epithelium.

Seminal fluid, besides spermatozoa, also contains *seminal cells*, a few epithelial cells from the seminal passages, numerous lecithin granules, stratified amyloid bodies (inconstant), granular yellow pigment, especially in old age, leucocytes, and sperma crystals (Fürbinger).

Development of Spermatozoa.—The walls of the seminal tubules, *n* which are made up of spindle-shaped cells, are lined by a nucleated, protoplasmic layer (Fig. 463, I, *b* and IV, *h*), from which there project into the lumen of the tube, long (0.053 mm.), column-like prolongations (I, *c*, and II, III, IV), which break up at their free end into several round or oval lobules (II), the *spermatoblasts* (v. Ebner); these consist of soft, finely granular protoplasm, and usually have an oval nucleus in their lower part. During development, each lobule of the spermatoblast elongates into a tail (IV, *r*), while the deeper part forms the head and middle piece of the future spermatozoon (IV, *k*). At this stage, the spermatoblast is like a greatly enlarged, irregular, cylindrical,

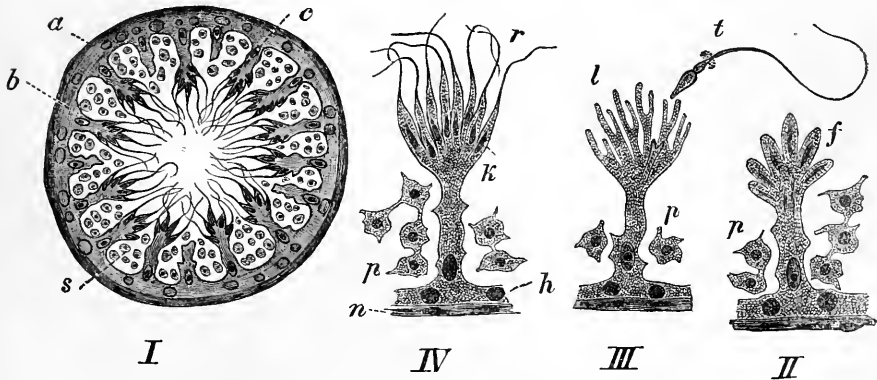

Fig. 463.

Semi-diagrammatic spermatogenesis: I, Transverse section of a seminal tubule—*a*, membrane; *b*, protoplasmic inner lining; *c*, spermatoblast; *s*, seminal cells. II, Unripe spermatoblast—*f*, rounded clavate lobules; *p*, seminal cells. IV, Spermatoblast, with ripe spermatozoa (*k*) not yet detached; tail, *r*; *n*, wall of the seminal tubule; *h*, its protoplasmic layer. III, Spermatoblast with a spermatozoon free, *t*.

epithelial cell. When development is complete, the head and middle piece are detached (III, *t*), and ultimately the remaining part of the spermatoblast undergoes fatty degeneration. Not unfrequently in

spermatozoa, we may observe a small mass of protoplasm adhering to the tail and the middle piece (III, *t*). Between the spermatoblasts are numerous, round, amœboid cells devoid of an envelope, and connected to each other by processes. They seem to secrete the *fluid* part of the semen, and they may therefore be called **seminal cells** (I, *s*, II, III, IV, *p*). A spermatozoon, therefore, is a detached, independently mobile cilium of an enlarged epithelial cell. Some observers adhere to the view that the spermatozoa are, in part at least, formed within round cells, by a process of endogenous development.

Shape.—The spermatozoa of most animals are like cilia with larger or smaller heads. The head is elliptical (mammals), or pear-shaped (mammals), or cylindrical (birds, amphibians, fish), or cork-screw (singing birds, paludina), or merely like hairs (insects—Fig. 462). Immobile seminal cells, quite different from the ordinary forms occur in myriapoda and the oyster.

433. The Ovary—Ovum—Uterus.

[**Structure of the Ovary** (Fig. 464).—The ovary consists of a connective-tissue framework, with blood-vessels, nerves, lymphatics, and numerous non-stripped muscular fibres. The ova are embedded in this matrix. The surface of the ovary is covered with a layer of columnar epithelium (Fig. 465, *e*), the remains of the *germ-epithelium*. The most superficial layer is called the *albuginea*; it does not contain any ova. Below it is the *cortical layer* of Schrön, which contains the smallest Graafian follicles ($\frac{1}{100}$ inch—Fig. 464), while deeper down are the larger follicles, $\frac{1}{30}$ to $\frac{1}{100}$ inch. There are 40,000–70,000 follicles in the ovary of a female infant. Each ovum lies within its follicle or Graafian vesicle.]

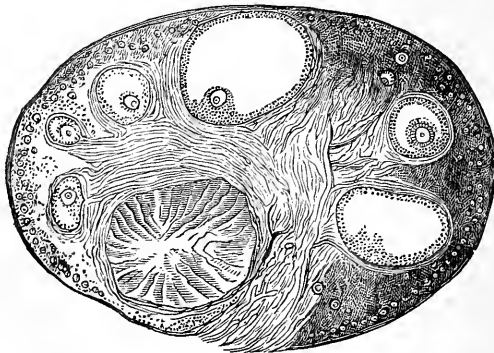

Fig. 464.

Section of a cat's ovary (Schrön). The place of attachment or hilum is below. On the left is a corpus luteum (Barbour and Hart).

Structure of an Ovum.—The human ovum (C. E. v. Baer, 1827) is 0.18–0.2 mm. [$\frac{1}{120}$ in.] in diameter, and is a spherical cellular body with a thick, solid, elastic envelope, the *zona pellucida*, with radiating striæ. The *zona pellucida* encloses the cell-contents, represented by the protoplasmic, granular, contractile *vitellus* or *yellk*, which in turn contains the eccentrically placed spherical nucleus or *germinal vesicle* (40–50 μ —Purkinje, 1825 ; Coste, 1834). The *germinal vesicle* contains the nucleolus or *germinal spot* (5–7 μ —R. Wagner, 1835). The *chemical composition* is given in § 232.

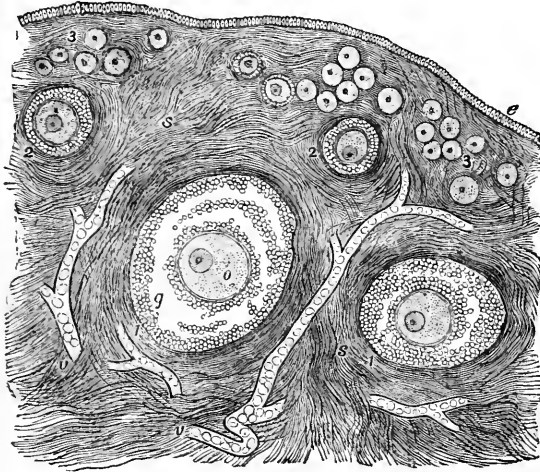

Fig. 465.

Section of an ovary (Turner)—*e*, Germ-epithelium; 1, large sized follicles; 2, 2, middle sized, and 3, 3, smaller sized follicles; *o*, ovum within a Graafian follicle; *v*, *v*, blood-vessels of the stroma; *g*, cells of the membrana granulosa (Hart and Barbour).

[Ovum.	Cell.
Zona pellucida corresponds to the	Cell-wall.
Vitellus	Cell-contents.
Germinal vesicle	Nucleus.
Germinal spot	Nucleolus.]

[This arrangement shows the corresponding parts in a cell and the ovum, and in fact the ovum represents a typical cell.]

The *zona pellucida* (Fig. 466, V, Z), to which cells of the Graafian follicle are often adherent, is a cuticular membrane formed secondarily by the follicle (Pflüger). According to van Beneden, it is lined by a thin membranc next the vitellus, and he regards the thin membrane as the original cell membrane of the ovum. The fine radiating striæ

in the zona are said to be due to the existence of numerous canals (Kölliker, v. Sehlen). It is still undecided whether there is a special *micropyle* or hole for the entrance of the spermatozoa.

A *micropyle* has been observed in some ova (holothurians, many fishes, mussels). The ova of some animals (many insects, *e.g.*, the flea) have porous canals in some part of their zona, and these serve both for the entrance of the spermatozoa, and for the respiratory exchanges in the ovum.

The development of the ova takes place in the following manner:—The surface of the ovary is covered with a layer of cylindrical epithelium—the so-called “*germ-epithelium*”—and between these cells lie, somewhat spherical, “*primordial ova*” (Fig. 466, I, *a, a*). The epithelium covering the surface dips into the ovary at various places to form “*ovarian tubes*” (Waldeyer). These tubes, from and in which the ova are developed (Waldeyer), become deeper and deeper, and they

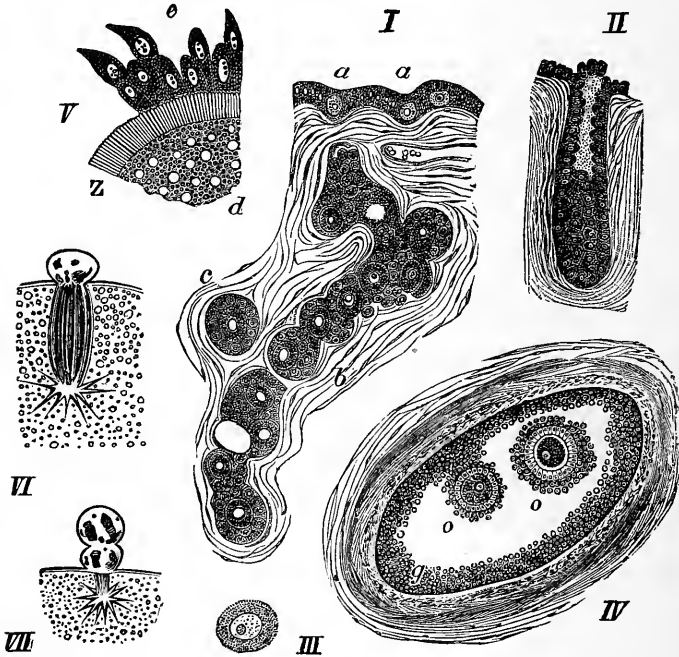

Fig. 466.

- I, An ovarian tube in process of development (new-born girl)—*a, a*, Young ova between the epithelial cells on the surface of the ovary; *b*, the ovarian tube with ova and epithelial cells; *c*, a small follicle cut off and enclosing an ovum. II, Open ovarian tube from a bitch. III, Isolated primordial ovum (human). IV, Older follicle with two ova (*o, o*) and the tunica granulosa (*g*) of a bitch. V, Part of the surface of a ripe ovum of a rabbit—*z*, Zona pellucida; *d*, vitellus; *e*, adherent cells of the membrana granulosa (after Waldeyer). VI, First polar globule formed. VII, Formation of the second polar globule (Fol).

contain in their interior large, single, spherical cells with a nucleus and a nucleolus, and other smaller and more numerous cells lining the tube. The large cells are the cells (*primordial ova*) that are to develop into ova, while the smaller cells are the epithelium of the tube, and are direct continuations of the cylindrical epithelium on the surface of the ovary. The upper extremities of the tubes become closed, while the tube itself is divided into a number of rounded compartments—snared off, as it were, by the ingrowth of the ovarian stroma (I, *c*). Each compartment so snared off usually contains one, or at most two, ova (IV, *a, o*), and becomes developed into a Graafian follicle. The embryonic follicle enlarges, and fluid appears within it; while its lateral small cells become changed into the epithelium, lining the Graafian follicle itself, or those of the *membrana granulosa*. The cells of the *membrana granulosa* form an elevation at one part—the *discus proli-gerus*—by which the ovum is attached to the *membrana granulosa*. The follicles are at first only 0.03 mm. in diameter, but they become larger, especially at puberty. [The smaller ova are near the surface of the ovary, the larger ones deeper in its substance (Fig. 464)]. When a Graafian follicle, with its ovum, is about to ripen (IV), it sinks or passes downwards into the substance of the ovary, and enlarges at the same time by the accumulation of fluid—the *liquor folliculi*—between the tunica and *membrana granulosa*. It is covered by a vascular outer membrane—the *theca folliculi*—which is lined by the epithelium constituting the *membrana granulosa* (IV, *g*). When a Graafian follicle is about to burst, it again rises to the surface of the ovary, and attains a diameter of 1.0–1.5 mm., and is now ready to burst and discharge its ovum. [The tissue between the enlarged Graafian follicle and the surface of the ovary gradually becomes thinner and thinner and less vascular, and at last gives way, when the ovum is discharged, and caught by the fimbriated extremity of the Fallopian tube embracing the ovary, so that the ovum is shed into the Fallopian tube itself.] Only a small number of the Graafian follicles undergo development normally, by far the greatest number atrophy, and never ripen. (The study of the development of the ova and ovary was advanced particularly by Martin Barry, Pfüger, Billroth, Schrön, His, Waldeyer, Kölliker, Koster, Lindgren, Schulin, Foulis, Balfour, and others.)

According to Waldeyer, the mammalian ovum is not a simple cell, but a compound structure. The original primitive ovum is, according to him, formed only of the germinal vesicle and germinal spot, with the surrounding membranous clear part of the vitellus (Fig. 466, III). The remainder of the vitellus is developed by the transformation of *granulosa* cells, which also form the *zona pellucida*.

Holoblastic and Meroblastic Ova.—The ova of frogs and cyclostomata are built on the same type as mammalian ova; they are called *holoblastic ova*, because all their contents go to form cells which take part in the formation of the embryo.

In contrast with these, the birds, the monotremes alone amongst the mammals (Caldwell), the reptiles, and the other fishes have *meroblastic ova* (Reichert). The latter, in addition to the white or formative yolk, which corresponds to the yolk of the holoblastic eggs, and gives rise to the embryonic cells, contains the food-yolk (yellow in birds), and which, during development, is a reserve store of food for the developing embryo.

Hen's Egg.—The small, white, round, finely granular speck, the *cicatricula blastoderm*, or *tread*, which is 2.5–3.5 mm. broad and 0.28–0.37 thick, lying upon the surface of the yellow yolk, corresponds to the contents of the mammalian ovum, and is, therefore, the formative yolk. [The *cicatricula* in an unincubated egg is always uppermost whatever the position of the egg, provided the contents can rotate freely, and this is due to the lighter specific gravity of that part of the yolk in connection with the *cicatricula*. In a fecundated egg the *cicatricula* has a white margin (the *area opaca*), surrounding a clear transparent area, the beginning of the *area pellucida*, containing an opaque spot in its centre. If an egg be boiled very hard and a section made of the yolk, it will be found to consist of alternating layers of white and yellow yolk. The outermost layer is a thin layer of white yolk, which is slightly thicker at the margin of the *cicatricula*. Within the centre of the yolk is a flask-shaped mass of white yolk, the neck of the flask being connected with the white yolk outside. This flask-shaped mass does not become so hard on being boiled, and its upper expanded end is known as the "*nucleus of Pander*." The great mass of the yolk is made up, however, of yellow yolk.] **Microscopically**, the *yellow yolk* consists of soft, yellow spheres of from 23–100 μ in diameter, and they are often polyhedral from mutual pressure. [They are very delicate and non-nucleated, but filled with fine granules, which are, perhaps, proteid in their nature, as they are insoluble in ether or alcohol. They are developed by the proliferation of the granulosa cells of the Graafian follicle, which also seem ultimately to form the granulo-fibrous double envelope or the *vitelline membrane* (Eimer). The whole yolk of the hen's egg is regarded by some observers as equivalent to the mammalian ovum plus the corpus luteum. Microscopically, the *white yolk* consists of small vesicles (5–75 μ) containing a refractive substance and larger spheres containing several smaller spherules. The whole yolk is enveloped by the *vitelline membrane*, which is transparent, but possesses a fine fibrous structure, and it seems to be allied to elastic tissue.] When the yolk is fully developed within the Graafian follicle of the hen's ovary, the follicle bursts and discharges the yolk, which passes into the oviduct, where in its passage it rotates, owing to the direction of the folds of the mucous membrane of the oviduct. The numerous glands of the oviduct secrete the *albumin*, or white of the egg, which is deposited in layers around the yolk in its passage along the duct, and forms at the anterior and posterior poles, the *chalazae*. [The *chalazae* are two twisted cords composed of twisted layers of the outer denser part of the albumin. They extend from the poles of the yolk not quite to the outer part of the albumin.] [The albumin is invested by the *membrana testacea*, or *shell membrane*, which is composed of two layers—an outer thicker and an inner thinner one. Over the greater part of the albumin these two layers are united, but, at the broad end of the hen's egg, they tend to separate, and air passing through the porous shell separates them more and more as the fluid of the egg evaporates. This air space is not found in fresh laid eggs.] The layers consist of spontaneously coagulated, keratin-like fibres arranged in a spiral manner around the albumin (Lindvall and Hamarsten). [External to this is the *test*, or *shell*, which consists of an organic matrix impregnated with lime salts.] The shell consists of albumin impregnated with lime salts, which form a very porous mortar. [The shell is porous, and its inner layer is perforated by vertical canals, through which the respiratory exchange of the gases can take place.] In the eggs of some birds there is an outer structureless, porous, slimy, or fatty cuticula. The shell is secreted in the lower part

of the oviduct. The shell is partly used up for the development of the bones of the chick (Prout, Gruwe, although this is denied by Polt and Preyer). The pigment which often occurs in many layers on the surface of the eggs of some birds appears to be a derivative of hæmoglobin and biliverdin.

Chemical Composition.—The *yellow yelk* is alkaline, and coloured yellow owing to the presence of *lutein*, which contains iron. It contains several proteids [including a globulin body called *vitellin*, p. 502], a body resembling nuclein, lecithin, vitellin, glycerin-phosphoric acid, cholesterin, olein, palmitin, dextrose, potassic chloride, iron, earthy phosphates, fluoric, and silicic acids. The presence of cerebrin, glycogen, and starch is uncertain. [Dareste states that starch is present.]

[The albumin of egg contains—water, 86 per cent.; proteids, 12; fat and extractives, 1·5; saline matter, including sodic and potassic chlorides, phosphates, and sulphates, ·5 per cent.]

[The uterus, a thick, hollow muscular organ, is covered externally by a *serous coat*, and lined internally by a *mucous membrane*, while between the two is the thick *muscular coat* composed of smooth muscular fibres arranged in a great number of layers and in different directions.

The muscularis mucosæ is very well developed, while the mucous membrane is lined by a single layer of columnar ciliated epithelium. A vertical section shows the mucous membrane to contain numerous tubular glands (Fig. 467)—the *uterine glands*—which branch towards their lower ends. They have a *membrana propria*, and are lined by a single layer of ciliated epithelium, a small lumen being left in the centre. The utricular glands are not formed during intrauterine life (Turner), nor are there any glands in the human uterus at birth (G. J. Engelmann).]

[In the *cervix* the mucous membrane is folded, presenting in the virgin

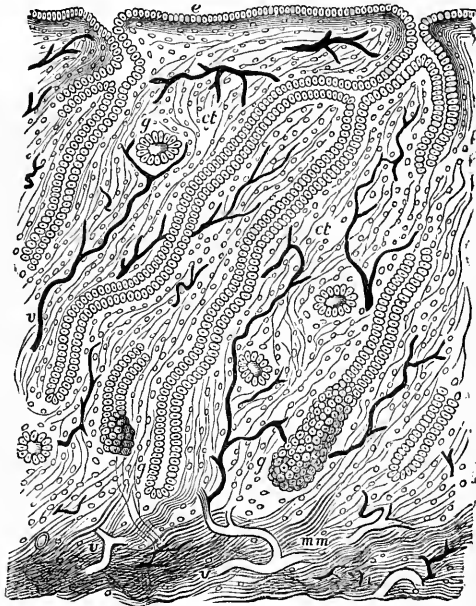

Fig. 467.

Vertical section of the mucous membrane of the human uterus (Turner)—*e*, columnar epithelium, the cilia absent; *g g*, utricular glands; *ct*, inter-glandular connective-tissue; *v v*, blood-vessels; *m m*, muscularis mucosæ (Hart and Barbour).

the appearance known as the arbor vitæ. The external surface of the vaginal part of the neck is covered by stratified squamous epithelium, like the vagina.]

[The Fallopian tubes are really the ducts of the ovaries (Fig. 468).

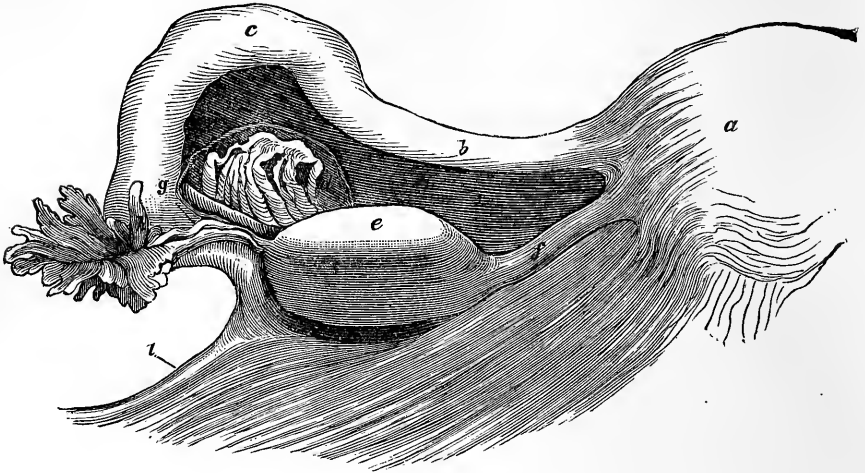

Fig. 468.

Left broad ligament, Fallopian tube, ovary, and parovarium (Henle)—*a*, uterus; *b*, isthmus of Fallopian tube; *c*, ampulla; *g*, fimbriated end of the tube, with the parovarium to its right; *e*, ovary; *f*, ovarian ligament (Hart and Barbour).

They consist of a serous, muscular (an external, longitudinal, and an internal circular layer), and a mucous layer lined by a single layer of ciliated columnar epithelium, but no glands.]

434. Puberty.

The term **puberty** is applied to the period at which a human being becomes capable of procreating, which occurs from the 13th–15th years in the female and the 14th–16th in the male. In warm climates, puberty may occur in girls even at 8 years of age. Towards the 40th–50th year, the procreative faculty ceases in the female with the cessation of the menses; this constitutes the *menopause* or *grand climacteric*, whilst in man, procreation has been observed up to any age. From the period of puberty onwards, the sexual appetite occurs, and the ripe ova are discharged from the ovary. [It seems, however, that ova are discharged even before puberty or menstruation has occurred.] At puberty, the internal and external generative organs and their annexes become more vascular and undergo development; the pelvis of the female assumes the characteristic female shape. For the changes

in the mammæ see § 230. At the same time hair is developed on the pubes and axilla, and in the male on the face, while the sebaceous glands become larger and more active.

Other changes occur especially in the *larynx*. In the boy the larynx elongates in its antero-posterior diameter, the thyroid, or Adam's apple, becomes more prominent, while the vocal cords lengthen, so that the voice is hoarse, or husky, or "breaks," the voice being lowered at least an octave. In the female, the larynx becomes longer, while the compass of the voice is increased. The vital capacity (p. 228) corresponding to the increase in the size of the chest, undergoes a considerable increase; the whole form and expression assume the characteristic sexual appearance, while the psychical energies also receive an impulse.

435. Menstruation.

External Signs.—At regular intervals of time, of $27\frac{1}{3}$ –28 days, in a mature female, there is a rupture of one or more ripe Graafian follicles, while, at the same time, there is a discharge of blood from the external genitals. This is known as the process of *menstruation* (or menses, catamenia, or periods). Most women menstruate during the first quarter of the moon, and only a few at new and full moon (Strohl). In mammals, the analogous condition is spoken of as the period of heat [or the "rut" in deer]. There is a slightly bloody discharge from the external genitals in carnivora, the mare, and cow (Aristotle), while apes, in their wild condition, have a well-marked menstrual discharge (Neubert).

The onset of menstruation is usually heralded by constitutional and local phenomena—there is an increased feeling of congestion in the internal generative organs, pain in the back and loins, tension in the region of the uterus and ovaries, which are sensitive to pressure, fatigue in the limbs, alternate feeling of heat and cold, and even a slight increase of the temperature of the skin (Kersch). There may be retardation of the process of digestion, and variations in the evacuation of the fæces and urine, and in the secretion of sweat. The discharge is *slimy* at first, and then becomes *bloody*, lasting 3 to 4 days; the blood is venous, and shows little tendency to coagulate, provided it is mixed with much alkaline mucus from the genital passages; but, if the hæmorrhage be free, the blood may be clotted. The quantity of blood is 100–200 grms. After cessation of the discharge of blood, there is a moderate amount of mucus given off.

The characteristic internal phenomena which accompany menstruation are:—1, The changes in the uterine mucous membrane; and 2, the rupture of the Graafian follicle.

Changes in the Uterine Mucous Membrane.—The uterine mucous membrane is the chief source of the blood. The ciliated epithelium of the congested, swollen, and folded, soft, thick (3–6 mm.) mucous membrane is shed. The orifices of the numerous mucous glands of the mucous membrane are distinct, and the cells undergo *fatty degeneration*,

and so do the tissue and the blood-vessels lying between the glands. This fatty degeneration and the excretion of the degenerated tissue occur, however, only in the superficial layers of the mucosa, whose blood-vessels, when torn across, yield the blood. The deeper layers remain intact, and from them, after menstruation is over, the new mucous membrane is developed (Kundrat and G. J. Engelmann).

[According to Williams, the entire mucous membrane is removed at each menstrual period, and it is regenerated from the muscular coat (Fig. 470).]

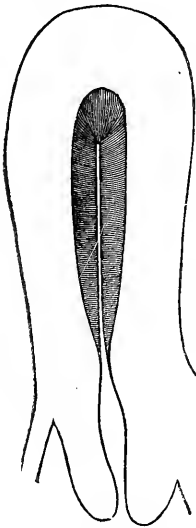

Fig. 469.

Diagram of the uterus just before menstruation. The shaded portion represents the mucous membrane (Hart and Barbour, after J. Williams).



Fig. 470.

Uterus when menstruation has just ceased, showing the cavity of the body deprived of mucous membrane (J. Williams).

Ovulation.—The second important internal phenomenon is *ovulation*, in which process the ovary becomes more vascular—the ripe follicle is turgid with fluid, and in part projects above the surface of the ovary. The follicle ultimately bursts, its membranes and the epithelial covering of the ovary being torn or give way under the pressure, the bursting being accompanied by the discharge of a small amount of blood. At the same time, the congested, turgid, and erected fimbriated extremity of the Fallopian tube (Fig. 468) is applied to the ovary, so that the discharged ovum, with its adherent granulosa cells, and the liquor folliculi, are caught by the funnel-shaped extremity of

the tube. The ovum, when discharged, is carried towards the uterus by the ciliated epithelium (p. 1112) of the tube, and, perhaps, also partly by the contraction of its muscular coat. Ducalliez and Kiess found that, by fully injecting the blood-vessels, they could imitate the erection of the Fallopian tube. Rouget points out that the non-striped muscle of the broad ligaments may cause constriction of the vessels, and thus secure the necessary injection of the blood-vessels of the Fallopian tube.

Pflüger's Theory.—There are two theories as to the connection between ovulation or the discharge of an ovum and the escape of blood from the uterine mucous membrane. Pflüger regards the bloody discharge from the superficial layers of the uterine mucous membrane as a physiological preparation or "freshening" of the tissue (in the surgical sense), by which it will be prepared to receive the ovum when the latter reaches the uterus, so that union can take place between the ovum and the freshly-exposed surface of the mucous membrane, and thus the ovum will receive nourishment from a new surface.

Reichert's Theory.—This view is opposed to that of Reichert, Engelmann, Williams, and others. According to Reichert's theory, before an ovum is discharged at all, there is a sympathetic change in the uterine mucous membrane, whereby it becomes more vascular, more spongy, and swollen up. The mucous membrane so altered is spoken of as the *membrana decidua menstrualis*, and from its nature it is in a proper condition to receive, retain, and nourish a fertilised ovum which may come into contact with it. If the ovum, however, be not fertilised, and escapes from the genital passages, then the uterine mucous membrane degenerates and blood is shed, as above described. According to this view, the hæmorrhage from the uterine mucous membrane is a sign of the non-occurrence of pregnancy; the mucous membrane degenerates because it is not required for this occasion; the menstrual blood is an external sign that the ovum has not been impregnated. So that pregnancy, *i.e.*, the development of the embryo in utero, is to be calculated, not from the last menstruation, but from some time between the last menstruation and the period which does not occur.

In some cases the ovulation and the formation of the decidua menstrualis occur separately, so that there may be menstruation without ovulation, and ovulation without menstruation.

Corpus Luteum.—When a Graafian follicle bursts, it discharges its contents and collapses; in the interior are the remains of the *membrana granulosa* and a small effusion of blood, which soon coagulates. The small rupture soon heals, after the serum is absorbed. The vascular wall of the follicle swells up. Villous prolongations or granulations of young connective-tissue, rich in capillaries and cells, grow into the interior of the follicle. Colourless blood-corpuscles also wander into the interior. At the same time the cells of the *granulosa* proliferate,

and form several layers of cells, which ultimately, after the disappearance of a number of blood-vessels, undergo fatty degeneration, *lutein* and *fatty* matter being formed, and it is this mass which gives the corpus luteum its yellow colour. The capsule becomes more and more fused with the ovarian stroma. If pregnancy does not take place after the menstruation, then the fatty matter is rapidly absorbed, and the effused blood is changed into hæmatoidin (§ 20), and other derivatives of hæmoglobin, while there is a gradual shrivelling of the whole mass, which is complete in about four weeks, only a very small remainder being left. Such a corpus luteum, *i.e.*, one not accompanied by pregnancy, is called a *false* corpus luteum. If, however, pregnancy occurs, then the corpus luteum, instead of shrivelling, grows and becomes a large body, especially at the third and fourth month, the walls are thicker, the colour deeper, so that the corpus luteum at the period of delivery may be 6-10 mm. in diameter, and its remains may be found in the ovary for a very long time thereafter (Fig. 464). This form is sometimes spoken of as a *true* corpus luteum (Bischoff). [We cannot draw too sharp a distinction between these two forms.] Only a very small number of the ova in the ovary undergo development and are discharged; by far the greater number degenerates (Slavjansky).

436. Erection.

Penis.—Our knowledge of the distribution of the blood within the penis is chiefly due to C. Langer's researches. The albuginea of the corpus spongiosum consists of tendinous connective-tissue, containing thickly-woven elastic-tissue and smooth muscular fibres, which together form a solid fibrous envelope, from which numerous interlacing trabeculæ pass into the interior, so that the corpus spongiosum comes to resemble a sponge. The anastomosing spaces bounded by these trabeculæ form a series of inter-communicating venous spaces or sinuses filled with blood and lined by a layer of endothelium. The largest sinuses lie in the lower and external part of the corpus cavernosum, while they are less numerous and smaller in the upper part. The small *arteries* arise from the A. profunda penis, which runs along the septum, and pass to the trabeculæ after following a very sinuous course. At the outer part of the corpus spongiosum, some of the small arteries become directly continuous with the larger venous sinuses; some of them, however, terminate in capillaries both in the outer part and within the corpus spongiosum, the *capillaries* ultimately terminating in the venous sinuses. The helicine arteries of the penis described by Joh. Müller are merely much twisted arteries. The *deep veins* of the penis arise by fine veinlets within the body of the organ, while the veins proceeding from the cavernous spaces pass to the dorsum of the penis to form the *vena dorsalis penis*. As these vessels have to traverse the meshes of the vascular net-work in the cortex of the corpora cavernosa penis, it is evident that, when the net-work is congested by being filled with blood, it must compress the outgoing venous trunks. The corpus cavernosum urethræ consists for the most part of an external layer of closely packed, anastomosing veins, which surround the longitudinally directed blood-vessels of the urethra.

In the dog, all the arteries of the penis run at first towards the surface, where they divide into penicilli. The veins arise from the capillary loops in the papillæ, and they empty their blood into the cavernous spaces. Only a small part of the blood passes to the cavernous spaces through the internal capillaries and veins, but arterial blood never flows directly into these spaces (M. v. Frey).

Mechanism of Erection.—Erection is due to the overfilling of the blood-vessels of the penis with blood, whereby the volume of the organ is increased four or five times, while at the same time there are also a

higher temperature, increased blood-pressure (to $\frac{1}{6}$ th of that in the carotid—Eckhard), with at first a pulsatile movement, increased consistence, and erection of the organ.

Regner de Graaf obtained complete erection of the penis by forcibly injecting its blood-vessels (1668).

The *preliminary phenomena* consist in a considerable increase of the arterial blood supply, the arteries being dilated and pulsating strongly. The arteries are controlled by the *nervi erigentes*. The *nervi erigentes* arise chiefly from the second (more rarely the third) sacral nerves (dog), and have ganglionic cells in their course (Lovén, Nikolsky). These nerves contain *vaso-dilator* fibres, which can be excited in part reflexly from the sensory nerves of the penis, the transference centre being in the centre for erection in the spinal cord (§ 362, 4). Sensory impressions produced by voluntary movements of the genital apparatus (by the ischio- and bulbo-cavernosi and cremaster muscles), can also discharge this reflex; while the thought of sexual impulses, referable to the penis, tends to induce erection. The *nervi erigentes* also supply the longitudinal fibres of the rectum (Fellner).]

The centre for erection in the spinal cord (§ 362, 2) is, however, controlled by the dominating *vaso-dilator* centre in the medulla oblongata (§ 372), and the two centres are connected by fibres within the cord; hence stimulation of the upper part of the cord, as by asphyxiated blood (§ 362, 5) or muscarin, may also be followed by erection (Nikolsky). [The seminal fluid is frequently found discharged in persons who have been hanged.]

The *psychical activity of the cerebrum* has a decided influence on the genital *vaso-dilator* nerves. Just as the psychical disturbance which accompanies anger or shame is followed by dilatation of the blood-vessels of the head, owing to stimulation of the *vaso-dilator* fibres, so when the attention is directed to the sexual centres, there is an action upon the *nervi erigentes*. This action of the brain is more comprehensible since we know that the diameter of the blood-vessels is affected by the cortex cerebri (§ 377). The fibres probably pass from the cerebrum through the peduncles of the cerebrum and the pons; as a matter of fact, if these parts be stimulated, erection may take place (§ 362, 4)—(Eckhard).

When the impulse to erection is obtained by the increased supply of arterial blood, the *full completion* of the act is brought about by the activity of the following transversely striped muscles:—1. The *ischio-cavernosus* (Fig. 129, p. 314) arises from the coccyx, and by its tendinous union surrounds the root of the penis. When it contracts, it compresses the root of the penis from above and laterally, so that the

outflow of blood from the penis is hindered (Varolius, 1573). It has no action on the dorsal vein of the penis, as this vessel lies in a groove on the dorsum of the penis, and is, therefore, protected from compression by the tendon. 2. The *deep transversus perinei* is perforated by the *venæ profundæ penis*, which come from the *corpora cavernosa*, so that when it contracts, it must compress these veins between the tense

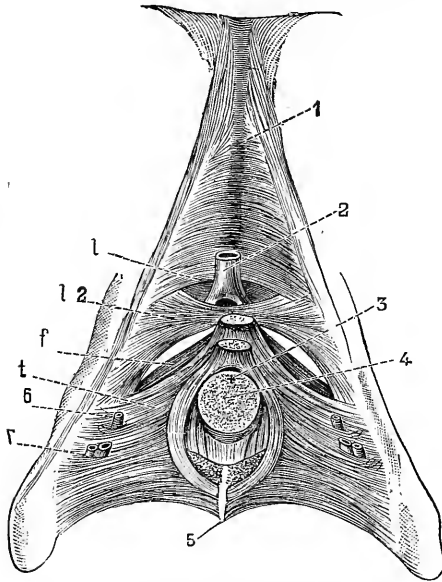

Fig. 471.

Anterior wall of the pelvis with the urogenital septum seen from the front. The corpus cavernosum (4) with the urethra (3) is cut across below its exit from the pelvis—1, Symphysis pubis; 2, dorsal vein of the penis; 5, part of the bulbocavernosus; *t*, deep transversus perinei with its fascia (*f*); 6, vena profunda penis; 7, artery and vein of the bulbocavernosum.

which, when it enlarges, must compress them. There are also trabecular smooth muscular fibres, which compress the large venous plexus of Santorini.

That erection is a complex motor act depending on the nervous system, is proved by an experiment of Hausmann, who found that section of the nerves of the penis prevented erection in a stallion. The imperfect erection which occurs in the female is confined to the corpora cavernosa clitoridis and the bulbi vestibuli. During erection, the passage from the urethra to the bladder is closed, partly by the swelling of the *caput gallinaginis*, and partly by the action of the sphincter urethrae, which is connected with the deep transversus perinei.

horizontal fibres (Fig. 471, 6—Henle). The deep veins of the penis join the common pudendal vein and the plexus Santorini. 3. Lastly, the *bulbo-cavernosus* is concerned in the hardening of the urethral corpus spongiosum, as it compresses the bulb of the urethra (Fig. 471, 5, and Fig. 129, p. 314). All these muscles are partly under the control of the will, whereby the erection may be increased. Normally, however, their contraction is excited *reflexly* by stimulation of the sensory nerves of the penis (§ 362, 4).

The congestion of blood is not complete, else, in pathological cases, continuous erection, as in satyriasis, would give rise to gangrene. The accumulation of the blood in the penis is favoured by the fact that, the origins of the veins of the penis lie in the corpus cavernosum,

437. Ejaculation—Reception of the Semen.

In connection with the ejaculation of the seminal fluid, we must distinguish two different factors—1, Its passage from the testicles to the vesiculæ seminales; 2, the act of ejaculation itself. The former is caused by the newly secreted fluid forcing on that in front of it, by the action of the ciliated epithelium (which lines the epididymis to the beginning of the vas deferens), and also by the peristaltic movements of the smooth muscular fibres of the vas deferens. Ejaculation, however, requires stronger peristaltic contractions of the vasa deferentia and the vesiculæ seminales, which are brought about by the reflex stimulation of the ejaculation centre in the spinal cord (§ 362, 5). As soon as the seminal fluid reaches the urethra, there is a rhythmical contraction of the bulbo-cavernosus muscle (produced by the mechanical dilatation of the urethra), whereby the fluid is forcibly ejected from the urethra. Both vasa deferentia and vesiculæ do not always eject their contents into the urethra simultaneously. With moderate excitement, the contents of only one may be discharged. The ischio-cavernosus and deep transversus perinei contract at the same time as the bulbo-cavernosus, although the former have no effect on the act of ejaculation. In the female also, under normal circumstances, at the height of the sexual excitement, there is a reflex movement corresponding to ejaculation. It consists of a movement analogous to that in man. At first there is a reflex peristaltic movement of the Fallopian tube and uterus, proceeding from the end of the tube towards the vagina, and produced reflexly by the stimulation of the genital nerves. Dembo observed that stimulation of the anterior upper wall of the vagina in animals caused a gradual contraction of the uterus. By this movement, corresponding to that of the vasa deferentia in man, a certain amount of the mucus normally lining the uterus is forced into the vagina.

This is followed by the rhythmical contraction of the sphincter cunni (analogous to the bulbo-cavernosus), also of the ischio-cavernosus, and deep transversus perinei. The uterus is erected by the powerful contraction of its muscular fibres and round ligaments, while at the same time it descends towards the vagina, its cavity is more and more diminished, and its mucous contents are forced out. When the uterus relaxes after the stage of excitement, it aspirates into its cavity the seminal fluid injected into the vestibule (Aristotle, Bischoff, Litzmann, Eichstedt).

But the suction of the greatly excited uterus is not necessary for the reception of the semen (Aristotle). The spermatozoa may wriggle by their own movements from the vagina into the orifice of the uterus (Kristeller). The cases of pregnancy where from some pathological causes (partial closure of the vagina or vulva), the

penis has not passed into the vagina during coition, prove that the spermatozoa can traverse the whole length of the vagina, and pass into the uterus.

438. Fertilisation of the Ovum.

The ovum is fertilised by a spermatozoon passing into it.

Swammerdam († 1685) proved that contact of the semen with the ovum was necessary for fertilisation. Spallanzani (1768) proved that the fertilising agent was the spermatozoa, and not the clear, filtered fluid part of the semen, and that the spermatozoa, even after being enormously diluted, were still capable of action. Martin Barry (1850) was the first to observe the entrance of a spermatozoon into the ovum of the rabbit. This occurs pretty rapidly, by a boring movement through the vitelline membrane (Leuckhart). The entrance is effected either through the porous canals or the micropyle (Keber—p. 1108).

Theories.—As to the manner in which the spermatozoon affects the ovum, there are great differences of opinion. Aristotle compared it to an action like that of rennet on milk; Bischoff, to that of yeast on a fermentable mass, *i.e.*, to a catalytic action. These theories, however, are quite unsatisfactory, as we know that, the unfertilised ova of the hen, rabbit (Hensen), pig (Bischoff), salpa (Kuppfer), (but not the frog—Pflüger) can undergo the initial stages of development as far as the stage of cleavage, and the star-fishes even as far as the larval form (Greef).

Place of Fertilisation.—The place where fertilisation occurs is either the *ovary*, as indicated by the occurrence of abdominal pregnancy, or the *Fallopian tube*, and the numerous recesses in the latter afford a good temporary nidus for the spermatozoa. This view is supported by the occurrence of tubal pregnancy. Thus the spermatozoa must be able to pass through the Fallopian tube to the ovary, which is probably brought about chiefly by the movements proper to the spermatozoa themselves. It is uncertain whether the peristaltic movements of the uterus and Fallopian tube are concerned in this process; certainly ciliary movement is not concerned, as the cilia of the Fallopian tube act from above downwards. When once the ovum has passed unfertilised into the uterus, it is not fertilised in the uterus. It is assumed that the ovum reaches the uterus within 2–3 weeks (in the bitch, 8–14 days).

Twins occur in 1 in 87 pregnancies, but oftener in warm climates; triplets, 1 : 7,600; four at a birth, 1 : 330,000. More than six at a birth have not been observed. The average number of pregnancies in a woman is $4\frac{1}{2}$.

Superfecundation.—By this term is understood the fertilisation of two ova at the same *menstruation*, by two different acts of coition. Thus, a mare may throw a foal and a mule, after being covered first by a stallion, and then by an ass. A white and a black child have been born as twins by a woman.

Superfoetation is when a second impregnation takes place at a *later* period of pregnancy, as in the second or third month. This, however, is only possible in a double uterus, or when menstruation persists until the time of the second impregnation. It is said to occur frequently in the hare.

Hybrids are produced when there is a cross between *different species* (horse, ass, zebra—dog, jackal, wolf—goat, ibex—goat, sheep—species of lama—camel, dromedary—tiger, lion—species of pheasant—goose, swan—carp, crucian—species of butterflies). Most hybrids are sterile, especially as regards the formation of properly formed spermatozoa; while the hybrid females are for the most part fertile with the male of both parents—*e.g.*, the mule; but the characters of the offspring tend to return to those of the species of the parents. Very few hybrids are fertile when crossed by hybrids. In many species of frogs, the absence of hybrids is accounted for by the mechanical obstacles to fertilisation of the ova.

Tubal Migration of the Ovum.—Under exceptional circumstances, the ovum discharged from a ruptured Graafian follicle passes into the Fallopian tube of the *other* side, as is proved by the occurrence of tubal pregnancy and pregnancy of an abnormal, rudimentary horn of the uterus, in which case the true corpus luteum is found on the *other side* of the ovary. This is spoken of as "*external migration*" (Kussmaul, Leopold.) This observation coincides with experiment, as granular fluids, *e.g.*, China-ink, when injected into the peritoneal cavity, pass into both Fallopian tubes, and are carried by the ciliated epithelium to the uterus (Pinner). In animals, with a double uterus with two orifices, the ova may migrate through the os of the one into the other uterus, a condition which is spoken of as "*internal migration*."

439. Impregnation of the Ovum—Cleavage—Layers and Position of the Embryo.

Maturation of the Ovum.—In birds and mammals important changes occur in the ovum before impregnation. The germinal vesicle comes to the surface and disappears from view, while the germinal spot also disappears (Rein). In place of the germinal vesicle, a spindle-shaped body appears. The granular elements of the protoplasmic vitellus arrange themselves around each of the two poles of the spindle, in the form of a star, the double-star, or diaster of Fol. When this takes place, the *peripheral pole* of the nucleus or altered germinal vesicle, along with some of the cellular substance of the ovum, protrudes upon the surface of the vitellus, where they are nipped off from the ovum in the form of small corpuscles just like an excretory product (Fig. 466). These bodies, which are not made use of in the further development and growth of the ovum, are called **polar or directing globules** (Fol, Bütschli, O. Hertwig), although the elimination of small bodies from the yolk was known to Dumortier [1837], Bischoff, P. J. van Beneden, Fritz Müller [1848], Rathke, and others. The remaining part of the germinal vesicle stays within the vitellus and travels back towards the

centre of the ovum, to form the female pronucleus (O. Hertwig, Fol, Selenka, E. van Beneden). [Before, however, the altered germinal vesicle travels downwards again into the substance of the ovum, it divides again as before, and from it is given off the second polar globule, and then the remainder of the germinal vesicle forms the female pronucleus. At the same time the vitellus shrinks somewhat within the vitelline membrane.]

Impregnation.—As a rule, only one spermatozoon penetrates the ovum, and as it does so it moves towards the female pronucleus, while its head becomes surrounded with a star; it then loses its head and cilium or tail, the latter only serving as a motor organ, while the remaining *middle piece* swells up to form a second new nucleus, the **male pronucleus** (Fol, Selenka). According to Flemming, it is the anterior part of the head, and, according to Rein and Eberth, it is the head which is so changed. Thereafter, the male and female pronucleus unite, undergoing amoeboid movements at the same time, to form the *new nucleus* of the *fertilised ovum*. The female pronucleus receives the male pronucleus in a little depression on its surface. Thereafter, the yelk assumes a radiate appearance (Rein). [The union of the representatives of the male and female elements forms the first *embryonic segmentation sphere* or *blastosphere*.]

In Echinoderms, O. Hertwig and Fol observed that several embryos were formed when, under abnormal conditions, several spermatozoa penetrated an ovum. The male pronuclei, formed from the several spermatozoa, then fused each with a fragment of the female pronucleus. Under similar circumstances, Born observed in amphibians abnormal cleavage, but no further development.

Cleavage of the Yelk.—In an ovum so fertilised, the yelk contracts somewhat around the newly-formed nucleus, so that it becomes slightly separated from the vitelline membrane, and for the first time the nucleus and the yelk divide into two nucleated spheres. This process

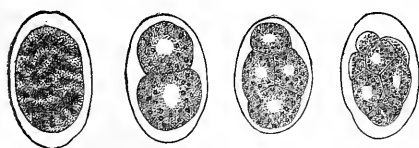

Fig. 472.

Cleavage of the yelk of the egg of
Anchylostomum duodenale.

is spoken of as *complete cleavage* or *fission*. Each of these two cells again divides into two, and the process is repeated, so that 4, 8, 16, 32, and so on, spheres are formed (Fig. 472). This constitutes the cleavage of the yelk, and the process goes on

until the whole yelk is subdivided into numerous small, nucleated spheres, the "**mulberry mass**" or "**segmentation spheres**," or "**morula**," or the protoplasmic primordial spheres (20–25 μ) which are devoid of an envelope.

Variation of Lines of Cleavage.—According to the observations of Pflüger, the ova of the frog can be made to undergo cleavage in very different directions, according to the angle between the axis of the egg and the line of gravitation. This, of course, we can alter as we please, by placing the eggs at any angle to the line of gravitation. By the axis of the ovum is meant a line connecting the centre of the black surface and the middle of the white part, which, in the fertilised ovum, is always vertical. In such cases of abnormal cleavage, the deposition of the organs takes place from other constituents of the egg, than those from which they are formed under normal conditions. Under normal circumstances, according to Roux, the first line of cleavage in the frog is in the same direction as the central nervous system. The second intersects the first at a right angle, so as to divide the mass of the ovum into two *unequal* parts, the larger of which forms the anterior part of the embryo.

Blastoderm.—During this time the ovum is enlarging by absorption of fluid into its interior. All the cells, from mutual pressure against each other, become polyhedral, and are so arranged as to form a cellular envelope or bladder, the *blastoderm*, which lies on the internal surface of the vitelline membrane (de Graaf, v. Baer, Bischoff, Coste). A small part of the cells not used in the formation of the blastoderm is found on some part of the latter. [In the ova of the bird, where there is only partial segmentation, the blastoderm is a small round body resting on the surface of the yelk, under the vitelline membrane, so that it does not completely surround the yelk, or a hollow cavity, as in mammals.] The hollow sphere, composed of cells, is called the *blastodermic vesicle* by Reichert, and in the human embryo it is formed at the 10th–12th day, in the rabbit at the 4th, the guinea-pig at the $3\frac{1}{2}$, the cat 7th, dog 11th, fox 14th, ruminantia at the 10th–12th day, and the deer at the 60th day.

When the blastoderm grows to 2 mm. (rabbit), whereby the vitelline membrane is distended to a very thin, delicate membrane, then at one part of it there appears the *germinal area*, the *area germinativa*, or the embryonal shield (Coste, Kölliker), as a round, white spot, in which the blastoderm, owing to proliferation of its cells, becomes *double*. The upper layer is called the *ectoderm* or *epiblast*, and in some animals it consists of several layers of cells, while the lower layer is the *endoderm* or *hypoblast*. The hypoblast continues to grow at its edges, so that it ultimately forms a completely closed sac, on which the epiblast is applied concentrically. The embryonal area soon becomes more pear-shaped, and afterwards biscuit-shaped. At the same time the surface of the zona pellucida develops numerous small, hollow, structureless villi, and is called the *primitive chorion*.

At the posterior part of the embryonic shield, the *primitive streak* (Fig. 473, I, *Pr*) appears, at first as an elongated circular thickening (Hensen), and later as a longer streak or groove, the *primitive groove*. This thickening, however, is confined to the epiblast, while the hypo-

blast is completely unchanged in the region of the streak, and the former consists of three layers of cells. At the same time a new layer of cells is developed between the epiblast and hypoblast, the *mesoderm* or *mesoblast* (Fig. 474, I), which soon extends over the embryonal area, and into the blastoderm. Blood-vessels are formed within the mesoblast, and are distributed over the blastoderm to form the *area vasculosa*.

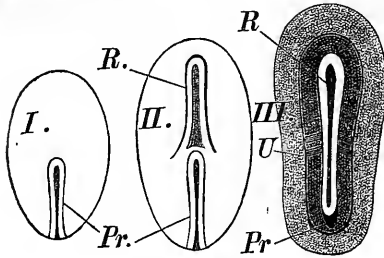

Fig. 473.

Pr, Primitive streak.
R, Medullary groove.
U, First protovertebra.

Medullary Groove.—A longitudinal groove, the medullary groove, is formed at the anterior part of the embryonal shield, but it gradually extends posteriorly, embracing the anterior part of the primitive streak with its divided posterior end, while the primitive streak itself gradually becomes relatively and absolutely smaller and less distinct, until it disappears altogether (Fig. 473, I and II, *Pr*—Kölliker).

The position of the embryo is indicated by the central part becoming more transparent, the *area pellucida*, which is surrounded by a more opaque part—the *area opaca*. [The *area opaca* rests directly upon the white yolk in the fowl, and it takes no share in the formation of the embryo, but gives rise to structures which are temporary, and are connected with the nutrition of the embryo. The embryo is formed in the *area pellucida* alone.]

From the *epiblast* [*neuro-epidermal layer*] are developed the central nervous system, and epidermal tissues, including the epithelium of the sense-organs.

From the *mesoblast* are formed most of the organs of the body, [including the vascular, muscular, and skeletal systems, and, according to some, the connective-tissue. It also gives rise to the generative glands and excretory organs].

From the *hypoblast*, *epithelio-glandular layer* [which is the secretory layer], arise the intestinal epithelium, and that of the glands which open into the intestine. [The mouth and anus being formed by an inpushing of the epiblast, are lined by epiblast, and are sometimes called the *stomodæum* and *protodæum* respectively.]

[Structure of the Blastoderm.—Originally, it is composed of only two layers, and in a vertical section of it the *epiblast* consists of a single row of nucleated, granular cells, arranged side by side with their long axes placed vertically. The *hypoblast* consists of larger cells than the foregoing, although they vary in size. They are spherical and very

granular, so that no nucleus is visible in them. The cells form a kind of net-work, and occur in more than one layer, especially at the periphery. It rests on white yelk, and under it are large spherical refractive cells, spoken of as *formative cells*.]

The cells of the epiblast, and especially those of the hypoblast, nourish themselves by the direct absorption and incorporation of the constituents of the yelk into themselves. The amœboid movements of these cells play a part in the process of absorption. The absorbed particles are changed, or, as it were, digested within the cells, and the product used in the processes of growth and development (Kollmann).

440. Structures Formed from the Epiblast.

Laminæ Dorsales.—The medullary groove upon the epiblast (also called outer, serous, sensorial, corneal, or animal layer) becomes deeper (Fig. 474, II). The two longitudinal elevations or *laminæ dorsales* consist of a thickening of the epiblast, and grow up over the medullary groove to meet each other and coalesce by their free edges in the middle line posteriorly. Thus the open groove is changed into a closed tube, the **medullary or neural tube** (III). The cells next the lumen of the tube ultimately become the ciliated epithelium lining the central canal of the spinal cord, while the other cells of the nipped-off portion of the epiblast form the ganglionic part of the central nervous system and its processes.

Primary Cerebral Vesicles.—[The laminæ dorsales unite first in the region of the neck of the embryo, and soon this is followed by the union of those over the future head.] The medullary tube is not of uniform diameter, for at the anterior end it becomes dilated and mapped out by constrictions into the primary vesicles of the brain, which at first are arranged, one behind the other, in the following order:—Each one being smaller than the one in front of it; the *fore-brain* (representing the structures from which the cerebral hemispheres are developed); the *mid-brain* (corpora quadrigemina); the *hind-brain* (cerebellum); and the *after-brain* (medulla oblongata), which is gradually continued into the spinal cord (IV and V). The posterior part of the medullary tube has a dilatation at the lumbar enlargement. In birds, the medullary groove remains open in this situation to form a lozenge-shaped dilatation, the sinus rhomboidalis.

Cranial Flexures.—The anterior part of the medullary tube curves on itself, especially at the junction of the spinal cord and oblongata, between the mid-brain and hind-brain, and again almost at right angles between the fore-brain and mid-brain. [Thus is produced a displacement of the primary vesicles, and the head of the future embryo is

mapped off.] At first all the cerebral vesicles are devoid of convolutions and sulci. On each side of the fore-brain there grows out a stalked hollow vesicle (VI), the primary *optic vesicle*. The remainder of the epiblast forms the epidermal covering of the body. At an early period we can distinguish the stratum corneum and the Malpighian layer of the skin (§ 283); from the former are developed the hairs, nails, feathers, etc.

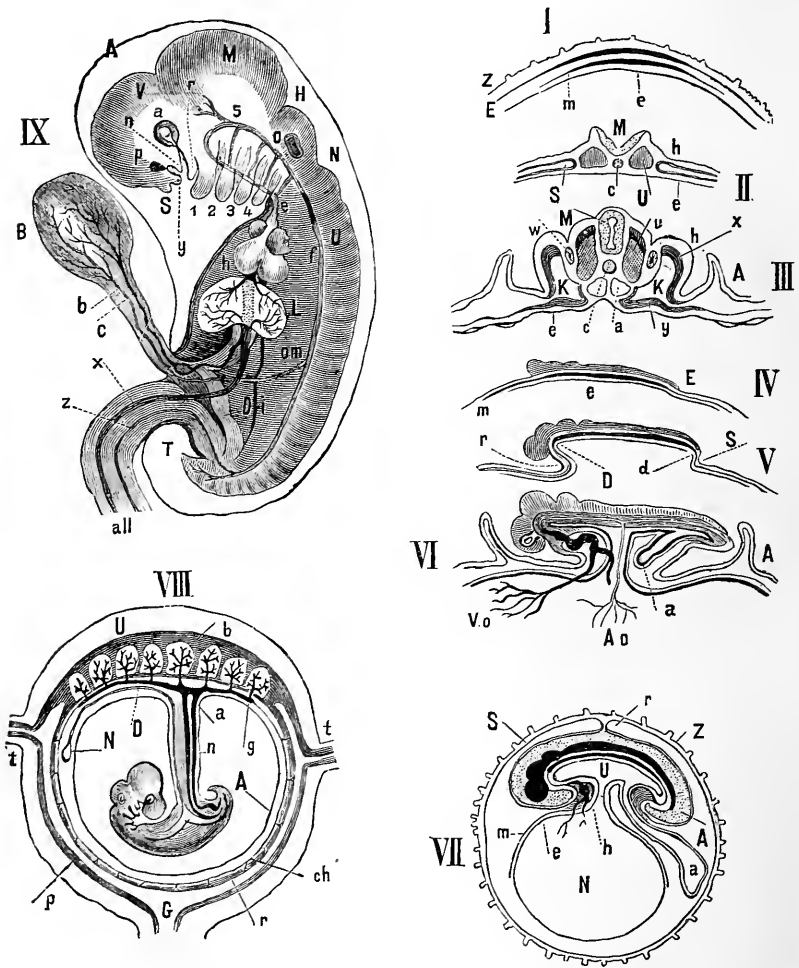

Fig. 474.

I, The three layers of the blastoderm of the mammalian ovum—Z, zona pellucida; E, ectoderm, or epiblast; *m*, mesoblast; *e*, endoderm, or hypoblast. II, Section of an embryo, with six protovertebrae at the 1st day—M, medullary groove; *h*, somatopleure; U, protovertebra; *c*, chorda dorsalis; S, the lateral plates divided into two; *e*, hypoblast. III, Section of an embryo

chick at the 2nd day, in the region behind the heart—M, medullary groove; *h*, outer part of somatopleure; *u*, protovertebra; *c*, chorda; *w*, Wolffian duct; K, cœlom; *x*, inner part of somatopleure; *y*, inner part of splanchnopleure; A, amniotic fold; *a*, aorta; *e*, hypoblast. IV, Scheme of a longitudinal section of an early embryo. V, Scheme of the formation of the head and tail folds—*r*, head fold; D, anterior extremity of the future intestinal tract; S, tail fold, first rudiment of the cavity of the rectum. VI, Scheme of a longitudinal section through an embryo after the formation of the head and tail folds—A *o*, omphalo-mesenteric arteries; V *o*, omphalo-mesenteric veins; *a*, position of the allantois; A, amniotic fold. VII, Scheme of a longitudinal section through a human ovum—Z, zona pellucida; S, serous cavity; *r*, union of the amniotic folds; A, cavity of the amnion; *a*, allantois; N, umbilical vesicle; *m*, mesoblast; *h*, heart; U, primitive intestine. VIII, Schematic transverse section of the pregnant uterus during the formation of the placenta; U, muscular wall of the uterus; *p*, uterine mucous membrane, or decidua vera; *b*, maternal part of the placenta, or decidua serotina; *r*, decidua reflexa; *ch*, chorion; A, amnion; *n*, umbilical cord; *a*, allantois, with the urachus; N, umbilical vesicle, with D, the omphalo-mesenteric duct; *t t*, openings of the Fallopian tubes; G, canal of the cervix uteri. IX, Scheme of a human embryo, with the visceral arches still persistent—A, amnion; V, fore brain; M, mid brain; H, hind brain; N, after brain; U, primitive vertebræ; *a*, eye; *p*, nasal pits; S, frontal process; *y*, internal nasal process; *n*, external nasal process; *r*, superior maxillary process of the 1st visceral arch; 1, 2, 3, and 4, the four visceral arches, with the visceral clefts between them; *o*, auditory vesicle; *h*, heart, with *e*, primitive aorta, which divides into five aortic arches; *f*, descending aorta; *om*, omphalo-mesenteric artery; *b*, the omphalo-mesenteric arteries on the umbilical vesicle; *c*, omphalo-mesenteric vein; L, liver, with venæ advehentes and revehentes; D, intestine; *i*, inferior cava; T, coccyx, *all*, allantois, with *z*, one umbilical artery, and *x*, an umbilical vein.

Partial Cleavage.—Only a partial cleavage takes place in the eggs of birds and in meroblastic ova, *i.e.*, only the *white yolk* in the neighbourhood of the cicatrix divides into numerous segmentation spheres (Coste, 1848). The cells arrange themselves in two layers lying one over the other. The upper layer or *epiblast* is the larger, and contains small pale cells; the lower layer, or *hypoblast*, which at first is not a continuous layer, ultimately forms a continuous layer, but its periphery is smaller than the upper layer, while its cells are larger and more granular.

Between the epiblast and hypoblast, from the primitive streak outwards, is formed the *mesoblast*, which is said by Kölliker to be due to the division of the cells of the epiblast. It gradually extends in a peripheral direction between the two other layers. All the three layers grow at their periphery. In the mesoblast, blood-vessels are developed. All the three layers, as they grow, come ultimately to enclose the whole yolk, so that their margins come together at the opposite pole of the yolk.

441. Structures Formed from the Mesoblast and Hypoblast.

The mesoblast (vascular layer or middle layer) forms immediately under the medullary groove, a cylindrical cellular cord, the *chorda dorsalis*, or *notochord*, which is thicker at the tail than at the cephalic

end (Fig. 474, II, III, *c*). It is present in all vertebrata, and also in the larval form of the ascidians, but in the latter it disappears in the adult form (Kowalewsky). In man it is relatively small. It forms the basis of the bodies of the vertebræ, and around it, as a central core, the substance of the bodies of the vertebræ is deposited, so that they are strung on it, as it were, like beads on a string. After it is formed, it becomes surrounded by a double sheath-like covering (Gegenbaur, Kölliker).

The recent observations of L. Gerlach and Strahl ascribe the origin of the chorda to the hypoblast. It does not contain chondrin or glutin, but albumin (Retzius).

Protovertebræ.—The cells of the mesoblast, on each side of the chorda, arrange themselves into cubical masses, always disposed in pairs behind each other, the *protovertebræ* (U and *u*). The first pair correspond to the atlas. At a later period, each protovertebra shows a marginal cellular area and a nuclear area. Only part of it goes to form a future vertebra. The part of the mesoblast lying external to the protovertebræ, the *lateral plates* (II, *s*) splits into two layers (Wolf, 1768), an upper one and a lower one, which, however, are united by a *median plate* at the protovertebræ. The space between the two layers of the mesoblast is called the *pleuro-peritoneal cavity*, or the *coelom* (III, K) of Haeckel. The upper layer of the lateral plate becomes united to the epiblast, and forms the cutaneo-muscular plate of German authors, or the *somatopleure* (III, *x*), while the inner one unites with the hypoblast to form the intestinal plate of German authors, or the *splanchnopleure* (III, *y*). On the surfaces of these plates, which are directed towards each other, the endothelium lining the pleuro-peritoneal cavity is developed. On the surface of the median plate, directed towards the coelom, some cylindrical cells, the "*germ-epithelium*" of Waldeyer remain, which form the ovarian tubes and the ova (§ 433).

According to Remak, the skin, the muscles of the trunk, and the blood-vessels, and according to His, only the musculature of the trunk, are derived from the somatopleure. Both observers agree that the splanchnopleure furnishes the musculature of the intestinal tract.

Parablastic and Archiblastic Cells.—According to His, the blood-vessels, blood, and connective-tissue are not developed from true mesoblastic cells, but he asserts that, for this purpose, certain cells wander in from the margins of the blastoderm between the epiblast and hypoblast; these cells being derived from outside the position of the embryo, from the elements of the white yolk. His calls these structures *parablastic*, in opposition to the *archiblastic*, which belong to the three layers of the embryo. Waldeyer also adheres to the parablastic structure of blood and connective-tissue, but he assumes that the material

from which the latter is formed is continuous protoplasm, and of equal value with the elements of the blastoderm.

The hypoblast does not undergo any change at this time, it applies itself to the inner layer of the mesoblast as a single layer of cells, to form the splanchnopleure.

442. Formation of the Embryo and Heart— Primitive Circulation.

Head- and Tail-Folds.—Up to this time the embryo lies with its three layers in the plane of the layers themselves. The cephalic end of the future embryo is first raised above the level of this plane (Fig. 474, V). In front of, and under the head, there is an inflection or tucking-in of the layers, which is spoken of as the *head-fold* (V, r). [It gradually travels backwards, so that the embryo is raised above the level of its surroundings.] The raised cephalic end is hollow, and it communicates with the space in the interior of the umbilical vesicle. The cavity in the head is spoken of as the *head-gut* or *fore-gut* (V, D). The formation of the fore-gut, by the elevation of the head from the plane of the three layers, occurs on the 2nd day in the chick, and in the dog on the 22nd day. The *tail-fold* is formed in precisely the same way in the chick on the 3rd day, and in the dog on the 22nd day. The caudal elevation, S, also is hollow, and the space within it is the *hind-gut*, d. Thus, the body of the embryo is supported, or rests on a hollow stalk, which at first is wide, and communicates with the cavity of the umbilical vesicle. This duct or communication is called the **omphalo-mesenteric duct**, or the **vitello-intestinal** or **vitelline duct**. The sacular vesicle attached to it in mammals is called the **umbilical vesicle** (VII, N), while the analogous, much larger sac in birds which contains the yellow nutritive yolk, is called the **yolk-sac**. The omphalo-mesenteric or vitelline duct, in course of time, becomes narrower, and is ultimately obliterated in the chick on the 5th day. The point where it is continuous with the abdominal wall is the abdominal umbilicus, and where it is inserted into the primitive intestine, the intestinal umbilicus.

[Sometimes part of the vitelline duct remains attached to the intestine, and may prove dangerous by becoming so displaced as to constrict a loop of intestine, and thus cause strangulation of the gut.]

Heart.—Before this process of constriction is complete, some cells are mapped off from that part of the splanchnopleure, which lies immediately under the head-gut; this indicates the *position of the heart*, which appears in the chick at the end of the first day, as a small, bright, red,

rhythmically contracting point, the *punctum saliens*, or the *στίγμα κινουμένη* of Aristotle. In mammals, it appears much later.

The heart, VI, begins first as a mass of cells, some of which, in the centre, disappear to form a central cavity, so that the whole looks like a pale hollow bud (originally a pair) of the splanchnopleure. The central cavity soon dilates, it grows, and becomes suspended in the coelom by a duplicature like a mesentery (meso-cardium), while the space which it occupies is spoken of as the *fovea cardica*. The heart now assumes an elongated tubular form, with its aortic portion directed forwards, and its venous end backward; it then undergoes a slight *f*-shaped curve (Fig. 480, 1). From the middle of the 2nd day, the heart begins to beat in the chick, at the rate of about 40 beats per minute. [It is very important to note that at first, although the heart beats rhythmically, it does not contain any nerve-cells.]

From the anterior end of the heart there proceeds, from the bulbus aortæ, the aorta which passes forward and divides into two arches, the *primitive aortæ*, which then curve and pass backwards under the cerebral vesicles, and run in front of the protovertebræ. Opposite the omphalo-mesenteric duct, each primitive aorta in the chick sends one, in mammals several (dog 4-5), omphalo-mesenteric arteries (VI, A, o), which spread out to form a vascular net-work within the mesoblast of the umbilical vesicle. From this net-work there arise the omphalo-mesenteric veins, which run backwards on the vitelline duct and end by two trunks in the venous end of the tubular heart. In the chick, these veins arise from the sinus terminalis of the subsequent vena terminalis of the area vasculosa. Thus, the *first* or *primitive circulation* is a closed system, and functionally, it is concerned in carrying nutriment and oxygen to the embryo. In the bird, the latter is supplied through the porous shell, and the former is supplied up to the end of brooding, by the yolk. In mammals, both are supplied by the blood-vessels of the uterine mucous membrane to the ovum. In birds, owing to the absorption of the contents of the yolk-sac, the vascular area steadily diminishes, until ultimately, towards the end of the brooding time, the shrivelled yolk-sac slips into the abdominal cavity. In mammals, the circulation on the umbilical vesicle, *i.e.*, through the omphalo-mesenteric vessels, soon diminishes, while the umbilical vesicle itself shrivels to a small appendix, and the *second circulation* is formed to replace the omphalo-mesenteric system. The first blood-vessels are formed in the chick, in the *area vasculosa*, outside the position of the embryo, at the last quarter of the first day, before any part of the heart is visible. The blood-vessels begin in vaso-formative cells [constituting the "*blood-islands*" of Pander]. At first they are solid, but they soon become hollow (§ 7, A).

A narrow-meshed plexus of *lymphatics* is formed in the area vasculosa of the chick (His), and it communicates with the amniotic cavity (A. Budge).

443. Further Formation of the Body.

Body-Wall.—1. The *coelom*, or pleuro-peritoneal cavity, becomes larger and larger, while at the same time the difference between the body-wall and the wall of the intestine becomes more pronounced. The latter becomes more separated from the protovertebræ, as the middle plate begins to be elongated to form a mesentery. The body-wall, or somatopleure, composed of the epiblast and the outer layer of the cleft mesoblast, becomes thickened by the ingrowth into it of the muscular layer from the muscle-plate, and the position of the bones and the spinal nerves from the protovertebræ. These grow between the epiblast and the outer layer of the mesoblast (Remak).

[The somatopleure, or parietal lamina, from each side grows forward and towards the middle line, where they meet to form the body-wall, while at the same time the splanchnopleure, or visceral lamina, on each side also grow and meet in the middle line, and when they do so, they enclose the intestine. Thus, there is one tube within the other, and the space between is the pleuro-peritoneal cavity.]

2. **Vertebral Column.**—A dorsally placed structure, called the *muscle-plate* (Remak) is differentiated from each of the protovertebræ; the remainder of the protovertebra, the protovertebra proper (Kölliker), coalesces with that on the other side, so that both completely surround the chorda, to form the *membrana reuniens inferior* (Reichert) in the chick on the 3rd, and in the rabbit on the 10th day, while, at the same time, they close over the medullary tube dorsally in the chick at the 4th day, to form the *membrana reuniens superior*. Thus, there is a union of the masses of the protovertebræ in *front* of the medullary tube, which encloses the chorda, and represents the basis of the *bodies* of all the vertebræ, whilst the *membrana reuniens superior*, pushed between the muscle-plates and the epiblast on the one hand, and the medullary tube on the other, represents the position of the entire vertebral *laminae*, as well as the intervertebral ligaments between them. In some rare cases the *membrana reuniens superior* is not developed, so that the medullary tube is covered only by the epiblast (epidermis), either throughout its entire extent, or at certain parts. This constitutes the condition of *spina bifida*, or, when it occurs in the head, hemicephalia. The vertebral column at this membranous stage is in the same condition as the vertebral column of the cyclostomata (*Petromyzon*). The membranes of the spinal cord, the spinal ganglia, and spinal nerves are formed from the *membrana reuniens superior*.

Lastly, parts of the somatopleures also grow towards the middle line

of the back, and insinuate themselves between the muscle-plate and the epiblast; thus, the dorsal skin is formed (Remak).

In the membranous vertebral column there are formed the several *cartilaginous* vertebræ, the one behind the other, in man at the 6th-7th week, although at first they do not form closed vertebral arches; the latter are closed in man about the 4th month. Each cartilaginous vertebra, however, is not formed from a pair of protovertebræ, *i.e.*, the 6th cervical vertebra from the 6th pair of protovertebræ, but there is a new subdivision of the vertebral column (Remak), so that the lower half of the preceding protovertebra and the upper half of the succeeding protovertebra unite to form the final vertebra. While the bodies are becoming cartilaginous, the chorda becomes smaller, but it still remains larger in the intervertebral discs. The body of the first vertebra or atlas unites with that of the axis to form its odontoid process (Rathke), and in addition it forms the arcus anterior atlantis and the transverse ligament (Hasse). The chorda can be followed upwards through the ligamentum suspensorium dentis as far as the posterior part of the sphenoid bone.

The *histogenetic formation* of cartilage from the indifferent formative cells takes place by division and growth of the cells, until they ultimately form clear nucleated sacs. The cement substance is probably formed by the outer parts of the cells (parietal substance) uniting and secreting the intercellular substance. It is supposed by some that the latter contains fine canals, which connect the protoplasm of the adjoining cells.

Visceral Clefts and Arches.—Each side of the cervical region contains 4 slit-like openings—the *visceral clefts* or *branchial openings* (Rathke); in the chick the upper 3 are formed at the 3rd, and the 4th on the 4th day. Above the slits are thickenings of the lateral wall, which constitute the *visceral* or *branchial arches*. The clefts are formed by a perforation from the fore-gut, but which, perhaps, does not always occur in the chick, mammal, and man (His), and they are lined by the cells of the hypoblast. On each side in each visceral arch, *i.e.*, above and below each cleft, there runs an aortic arch, 5 on each side (Fig. 474, IX). These aortic arches persist in fishes. In

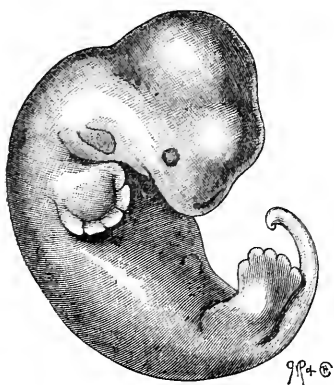

Fig. 475.

Embryo of the mole, $\times 7$ (W. K. Parker).

man, all the slits close except the uppermost one, from which the

auditory meatus, the tympanic cavity, and the Eustachian tube are developed (Huschke, Rathke, Reichert). The 4 visceral arches are for the most part made use of later for other formations (p. 1143).

Primitive Mouth and Anus.—Immediately under the fore-brain, in the middle line, is a thin spot, where there is at first a small depression, and ultimately a rupture, forming the *primitive oral aperture*, which represents both the mouth and the nose. Similarly, there is a depression at the caudal end, and the depression ultimately deepens, thus communicating with the hind-gut to form the anus. When the latter part of the process is incomplete, there is *atresia ani*, or imperforate anus. Several processes are given off from the primitive intestine, including the hypoblast and its muscular layers, to form the lungs, the liver, the pancreas, the cæcum (in birds), and the allantois.

The extremities appear at the sides of the body as short unjointed stumps or projections (Fig. 475), [at the 3rd or 4th week in the human embryo].

444. Formation of the Amnion and Allantois.

Amnion.—During the elevation of the embryo from its surroundings, immediately in front of the head, (at the end of the 2nd day in the chick), there rises up a fold consisting of the epiblast and the outer layer of the mesoblast, which gradually extends to form a sort of hood over the cephalic end of the embryo (VI, A). In the same way, but somewhat later, a fold rises at the caudal end, and between both along the lateral borders similar elevations occur, the lateral folds (Fig. 474, III, A). All these folds grow over the back of the embryo to meet over the middle line posteriorly, where they unite at the 3rd day in the chick to form the *amniotic sac*. Thus, a *cavity* which becomes filled with fluid—the *amniotic fluid*—is developed around the embryo, [so that the embryo really floats in the fluid of the amniotic sac]. In mammals also the amnion is developed very early, just as in birds (Fig. 474, VII, A). From the middle of pregnancy onwards, the amnion is applied directly to the chorion, and united to it by a gelatinous layer of tissue, the *tunica media* of Bischoff.

Amniotic Fluid.—The amnion, and the allantois as well, are formed only in mammals, birds, and reptiles, which have hence been called *amniota*, while the lower vertebrates, which are devoid of an amnion, are called *anamnia*. The *amniotic fluid* is a clear, serous, alkaline fluid, specific gravity 1007–1011, containing, besides epithelium, lanugo hairs, $\frac{1}{4}$ –2 per cent. of fixed solids. Amongst the latter are albumin ($\frac{1}{10}$ to $\frac{1}{3}$ per cent.), mucin, globulin, a vitelline-like body, some grape-sugar, urea, ammonium carbonate, very probably derived from the decomposition of urea, sometimes lactic acid and kreatinin, calcic sulphate and phosphate, and common

salt. About the middle of pregnancy it amounts to about 1·5 kilo. [2·2-3·3 lbs.], and at the end about 0·5 kilo. The amniotic fluid is of fetal origin, as is shown by its occurrence in birds, and is, perhaps, a transudation through the fetal membranes. In mammals, the urine of the fetus forms part of it during the second half of pregnancy (Gusserow). In the pathological condition of *Hydramnion*, the blood-vessels of the uterine mucous membrane secrete a watery fluid. The fluid preserves the fetus, and also the vessels of the fetal membranes from mechanical injuries; it permits the limbs to move freely, and protects them from growing together; and, lastly, it is important for dilating the os uteri during labour. The amnion is capable of contraction at the 7th day in the chick; and this is due to the smooth muscular fibres which are developed in the cutaneous plate in its meso-elastic portion (Remak), but nerves have not been found.

Allantois.—From the anterior surface of the caudal end of the embryo there grows out a small double projection, which becomes hollowed out to form a sac projecting into the cavity of the coelom or pleuro-peritoneal cavity (VI, *a*); it constitutes the *allantois*, and is formed in the chick before the 5th day, and in man during the 2nd week. Being a true projection from the hind-gut, the allantois has two layers, one from the hypoblast and the other from the muscular layer, so that it is an offshoot from the splanchnopleure. From both sides there pass on to the allantois the *umbilical arteries* from the hypogastric arteries, and they ramify on the surface of the sac. The allantois grows, like a urinary bladder gradually being distended, in front of the hind-gut in the pleuro-peritoneal cavity towards the umbilicus; and lastly, it grows out of the umbilicus, and projects beyond it alongside the omphalo-mesenteric or vitelline duct, its vessels growing with it (VII, *a*); but after this stage it behaves differently in birds and mammals.

In **birds**, after the allantois passes out of the umbilicus, it undergoes great development, so that within a short time it lines the whole of the interior of the shell as a highly vascular and saccular membrane. Its arteries are at first branches of the primitive aortæ, but with the development of the posterior extremities, they appear as branches of the hypogastric arteries. Two allantoidal, or *umbilical veins*, proceed from the numerous capillaries of the allantois. They pass backward through the umbilicus, and at first unite with the omphalo-mesenteric veins to join the venous end of the heart. In birds, this circulation on the allantois, or *second circulation*, is *respiratory* in function, as its vessels serve for the exchange of gases through the porous shell. This circulation gradually assumes the respiratory functions of the umbilical vesicle, as the latter gradually becomes smaller and smaller, and ceases to be a sufficient respiratory organ. Towards the end of the brooding time, the chick may breathe and cry within the shell (Aristotle)—a proof that the respiratory function of the allantois is partly taken over by the lungs. The allantois is also the *excretory* organ of the urinary constituents. Into its cavity in mammals the ducts of the *primitive kidneys*, or the *Wolffian ducts*, open, but in birds and reptiles, which possess a cloaca, these open into the posterior wall of the cloaca. The primitive kidneys, or Wolffian bodies, consist of many glomeruli, and empty their secretion through the Wolffian ducts into the allantois (in birds into the cloaca), and the secretion passes through the allantois, per the umbilicus, into the peripheral part of the urinary sac. Remak found ammonium and sodium urate, allantoin, grape-sugar, and salts in the contents of the allantois. From the 8th day onwards, the allantois of the chick is contractile (Vulpian),

owing to the presence of smooth fibres derived from the splanchnopleure. Lymphatics accompany the branches of the arteries (A. Budge).

Allantois in Mammals.—In mammals and man the relation of the allantois is somewhat different. The first part or its origin forms the *urinary bladder*, and from the vertex of the latter there proceeds through the umbilicus a tube, the *urachus*, which is open at first (VIII, a). The blind part of the sac of the allantois outside the abdomen is in some animals filled with a fluid like urine. In man, however, this sac disappears during the second month, so that there remains only the vessels which lie in the muscular part of the allantois. In some animals, however, the allantois grows larger, does not shrivel, but obtains through the urachus from the bladder an alkaline, turbid fluid, which contains some albumin, sugar, urea, and allantoin. The relations of the umbilical vessels will be described in connection with the foetal membranes.

445. Human Foetal Membranes—Placenta— Foetal Circulation.

Decidua.—When a fecundated ovum reaches the uterus, it then becomes surrounded by a special covering, which William Hunter (1775) describes as the *membrana decidua*, because it was shed at birth.

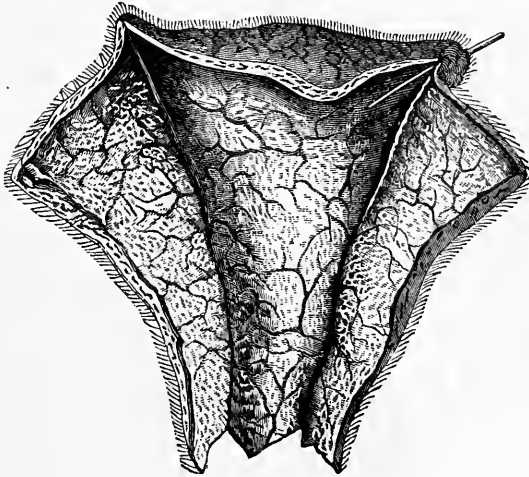

Fig. 476.

A dysmenorrhœal membrane laid open (after Coste).

We distinguish the *decidua vera* (Fig. 474, VIII, *p*), which is merely the thickened, very vascular, softened, more spongy, and somewhat altered mucous membrane of the uterus. [Sometimes in a diseased condition, as in dysmenorrhœa, the superficial layer of the uterine mem-

brane is thrown off *en masse* in a triangular form (Fig. 476). This serves to show the shape of the decidua, which is that of the uterus.] When the ovum reaches the uterus, it is caught in a crypt or fold of the decidua, and from the latter there grow up elevations around the ovum; but these elevations are thin, and soon meet over the back of the ovum to form the *decidua reflexa* (VIII, *r*). At the 2nd-3rd month, there is still a space in the uterus outside the reflexa; in the 4th month, the whole cavity is filled by the ovum. At one part the ovum lies directly upon the vera, [and that part is spoken of as the *decidua serotina*], but by far the greatest part of the surface of the ovum is in contact with the reflexa. In the region of the *D. serotina* the *placenta* is ultimately formed.

Structure of the Decidua Vera.—The *D. vera* is continued into the mucous membrane of the Fallopian tube and the cervix; at the 3rd month it is 4-7 mm. thick, and at the 4th only 1-3 mm., and it no longer has any epithelium; but it is very vascular, and is possessed of lymphatics around the glands and blood-vessels (Leopold), and in its loose substance are large, round cells (*decidua cells*—Kölliker), which in the deeper parts become changed into fibre cells—there are also lymphoid cells. The uterine glands, which become greatly developed at the commencement of pregnancy, at the 3rd to the 4th month form non-cellular, wide, bulging tubes, which become indistinct in the later months, and in which the epithelium disappears more and more. The *reflexa*, much thinner than the vera from the middle of pregnancy, is devoid of epithelium, and is without vessels and glands. Towards the end of pregnancy both deciduæ unite.

The ovum, covered at first with small hollow villi, is surrounded by the decidua. From the formation of the amnion it follows that, after it is closed, a completely closed sac passes away from the embryo to lie next the primitive chorion. This membrane is the "serous covering" of v. Baer (Fig. 474, VII, *s*), or the *false amnion*. It becomes closely applied to the inner surface of the chorion, and extends even into its villi. The allantois proceeding from the umbilicus comes to lie directly in contact with the foetal membrane; its sac disappears about the 2nd month in man, but its vascular layer grows rapidly and lines the whole of the inner surface of the chorion, where it is found on the 18th day (Coste). From the 4th week the blood-vessels, along with a covering of connective-tissue, branch and penetrate into the hollow cavities of the villi, and completely fill them. At this time the primitive chorion disappears. Thus we have a stage of general vascularisation of the chorion. In the place of the derivative of the zona pellucida we have the vascular villi of the allantois, which are covered by the epiblastic cells derived from the false amnion. This stage lasts only until the 3rd month; when the chorionic villi disappear all over the surface of the ovum in contact with the decidua reflexa. On the other hand, the villi of the chorion, where they lie in

direct contact with the decidua serotina, become larger and more branched. Thus, there is distinguished the *chorion laeve* and *frondosum*.

The chorion laeve, which consists of a connective-tissue matrix covered externally by several layers of cells, has a few isolated villi at wide intervals. Between the chorion and the amnion is a gelatinous substance (*membrana intermedia*) or undeveloped connective-tissue.

Placenta.—The large villi of the chorion frondosum penetrate into the tissue of the decidua serotina of the uterine mucous membrane. [It was formerly supposed that the chorionic villi entered the mouths of the uterine glands, but the researches of Ercolani and Turner have shown that, although the uterine glands enlarge during the early months of utero-gestation, the villi do not enter the glands. The villi enter the crypts of the uterine mucous membrane. The glands of the inner layer of the decidua serotina soon disappear.] As the villi grow into the decidua serotina, they push against the walls of the large blood-vessels, which are similar to capillaries in structure, so that the villi come to be bathed by the blood of the mother in the uterine sinuses, or they float in the colossal decidual capillaries (VIII, *b*). The villi do not float naked in the maternal blood, but they are covered by a layer of cells derived from the decidua. Some villi, with bulbous ends, unite firmly with the tissue of the uterine part of the placenta to form a firm bond of connection. [The placenta is formed by the mutual inter-growth of the chorionic villi and the decidua serotina.] Thus, it consists of a *fœtal* part, including all the villi, and a *maternal* or uterine part, which is the very vascular decidua serotina. At the time of birth, both parts are so firmly united that they cannot be separated. Around the margin of the placenta is a large venous vessel, the *marginal sinus* of the placenta. The placenta is the nutritive, excretory and respiratory organ of the fœtus (§ 368); the latter receives its necessary pabulum by endosmosis from the maternal sinuses through the coverings and vascular wall of the villi in which the fœtal blood circulates. [The placenta also contains *glycogen*.]

Uterine Milk.—Between the villi of the placenta there is a clear fluid which contains numerous small albuminous globules, and this fluid, which is abundant in the cow, is spoken of as the uterine milk. It seems to be formed by the breaking up of the decidual cells. It has been supposed to be nutritive in function. [The maternal placenta, therefore, seems to be a secreting structure, while the fœtal part has an absorbing function. The uterine milk has been analysed by Gamgee, who found that it contained fatty, albuminous, and saline constituents, while sugar and casein were absent.]

The investigations of Walter show that, after poisoning pregnant animals with strychnin, morphia, veratrin, curara, and ergotin, these substances are not found in the fœtus, although many other chemical substances pass into it.

[Savory found that strychnin injected into a fœtus in utero caused tetanic convulsions in the mother (bitch), while syphilis may be communicated from the father to the mother through the medium of the fœtus (Hutchinson). A. Harvey's record of observations on the crossing of breeds of animals—chiefly of horses and allied species—show that materials can pass from the fœtus to the mother.]

On looking at a placenta, it is seen that its villi are distributed on large areas separated from each other by depressions. This complex arrangement might be compared with the cotyledons of some animals.

The **position of the placenta** is, as a rule, on the anterior or posterior wall of the uterus, more rarely on the fundus uteri, or laterally, from the opening of the Fallopian tube, or over the internal orifice of the cervix, the last constituting the condition of *placenta prævia*, which is a very dangerous form of placental insertion, as the placenta has to be ruptured before birth can take place, so that the mother often dies from hæmorrhage. The umbilical cord may be inserted in the centre of the placenta (*insertio centralis*), or more towards the margin (*ins. marginalis*), or the cord may be fixed to the chorion laeve. Sometimes, though rarely, there are small subsidiary placenta (*pl. succenturiata*), in addition to the large one (Hyrtl). When the placenta consists of two halves, it is called duplex or bipartite, a condition said by Hyrtl to be constant in the apes of the old world.

Structure of the Cord.—The umbilical cord (48–60 cm. [20–24 inches] long, 11–13 mm. thick) is covered by a sheath from the amnion. The blood-vessels make about 40 spiral turns, and they begin to appear about the 2nd month. It contains two strongly muscular and contractile arteries, and one umbilical vein. The two arteries anastomose in the placenta (Hyrtl). In addition, the cord contains the continuation of the urachus, the hypoblastic portion of the allantois (VIII, *a*), which remains until the 2nd month, but afterwards is much shrivelled. The omphalo-mesenteric duct of the umbilical vesicle (N) is reduced to a thread-like stalk (VIII, *D*). Wharton's jelly surrounds the umbilical blood-vessels. Wharton's jelly is a gelatinous-like connective-tissue, consisting of branched corpuscles, lymphoid cells, some connective-tissue fibrils, and even elastic fibres. It yields mucin. It is traversed by numerous juice-canals, lined by endothelial cells, but other blood- and lymphatic-vessels are absent. Nerves occur 3–8–11 cm. from the umbilicus (Schott, Valentin).

The fœtal circulation, which is established after the development of the allantois, has the following course:—The blood of the fœtus passes from the hypogastric arteries through the two umbilical arteries, through the umbilical cord to the placenta, where the arteries split up into capillaries. The blood is returned from the placenta by the umbilical vein, although the colour of the blood cannot be distinguished from the venous or impure blood in the umbilical arteries. The umbilical vein (Fig. 483, 3, *u*), returns to the umbilicus, passes upwards under the margin of the liver, gives a branch to the vena portæ (*a*), and runs as the *ductus venosus* into the inferior vena cava, which carries the blood into the right auricle. Directed by the

Eustachian valve and the tubercle of Lower (Fig. 480, 6, *t*, *L*), the great mass of the blood passes through the *foramen ovale* into the left auricle, from which it cannot pass backwards into the right auricle, owing to the presence of the valve of the foramen ovale. From the left auricle it passes into the left ventricle, aorta, and hypogastric arteries, to the umbilical arteries. The blood of the superior vena cava of the foetus passes from the right auricle into the right ventricle (Fig. 480, 6, *Cs*). From the right ventricle it passes into the pulmonary artery (Fig. 480, 7, *p*), and through the *ductus arteriosus* of Botalli (*B*), into the aorta. [There are, therefore, two streams of blood in the right auricle which cross each other, the descending one from the head through the superior vena cava, passing in front of the transverse one from the inferior vena cava to the foramen ovale.] Only a small amount of the blood passes through the as yet small branches of the pulmonary artery to the lungs (Fig. 480, 7, *1*, *2*). The course of the blood makes it evident that the head and upper limbs of the foetus are nourished by purer blood than the remainder of the trunk, which is supplied with blood mixed with the blood of the superior vena cava. After birth, the umbilical arteries are obliterated, and become the lateral ligaments of the bladder, while their lower parts remain as the superior vesical arteries. The umbilical vein is obliterated, and remains as the ligamentum teres, or round ligament of the liver, and so is the ductus venosus Arantii. Lastly, the foramen ovale is closed, and the ductus arteriosus is obliterated, the latter forming the lig. arteriosum.

The condition of the membranes where there are more fetuses than one:—
 1. With twins there are two completely separated ova, with two placentas and two deciduæ reflexæ. 2. Two completely separate ova may have only one reflexa, whereby the placentas grow together, while their blood-vessels remain distinct. The chorion is actually double, but cannot be separated into two lamellæ at the point of union. 3. One reflexa, one chorion, one placenta, two umbilical cords, and two amnia. The vessels anastomose in the placenta. In this case there is one ovum with a double yolk, or with two germinal vesicles in one yolk. 4. As in 3, but only one amnion, caused by the formation of two embryos in the same blastoderm of the same germinal vesicle.

Formation of the foetal membranes in animals.—The oldest mammals have no placenta or umbilical vessels; these are the *Mammalia implacentalia* (Owen), including the monotremata and marsupials. The second group includes the *Mammalia placentalia*. Amongst these (*a*) the *non-deciduata* possess only chorionic villi supplied by the umbilical vessels, which project into the depressions of the uterine mucous membrane, and from which they are pulled out at birth (Pl. diffusa, e.g., pachydermata, cetacea, solidungula, camelidæ). In the *ruminants*, the villi are arranged in groups or cotyledons, which grow into the uterine mucous membrane, from which they are pulled out at birth. (*b*) In the *deciduata*, there is such a firm union between the chorionic villi with the uterine mucous membrane, that the uterine part of the placenta comes away with the foetal part at birth. In this case the placenta is either *zouary* (carnivora, pinnipedia, elephant), or *discoid* (apes, insectivora, edentata, rodentia).

446. Chronology of Human Development.

Development during the 1st Month.—At the 12th–13th day the ovum is saccular (5·5 mm. and 3 mm. in diameter); there is simply the blastodermic vesicle, with the blastoderm at one part, consisting of two layers; the zona pellucida beset with small villi (Reichert).

At the 15th–16th day, the ovum (5–6 mm.) is covered with simple cylindrical villi. The zona pellucida consists of embryonic connective-tissue, covered with a layer of flattened epithelium. The primitive groove and the laminae dorsales appear. Then follows the stage when the allantois is first formed.

At the 15th–18th day, Coste investigated an ovum. It was 13·2 mm. long, with small branched villi; the embryo itself was 2·2 mm. long, of a curved form, and with a moderately enlarged cephalic end. The amnion, umbilical vesicle with a wide vitelline duct, and the allantois were developed, the last already united to the false amnion. The S-formed heart lies in the cardiac cavity, shows a cavity and a bulbus aortæ, but neither auricles nor ventricles. The visceral arches and clefts are indicated, but they are not perforated. The omphalo-mesenteric vessels forming the first circulation on the umbilical vesicle are developed, the duct (vitelline) is still quite open, and two primitive aortæ run in front of the proto-vertebræ. The allantois attached to the foetal membranes is provided with blood-vessels. The two omphalo-mesenteric veins unite with the two umbilical veins, and pass to the venous end of the heart. The mouth is in process of formation. The limbs and sense-organs absent; the Wolffian bodies probably present.

At the 20th day, all the visceral arches are formed, and the clefts are perforated. The mid brain forms the highest part of the brain, while the two auricles appear in the heart. The connection with the umbilical vesicle is still moderately wide. The embryo is 2·6–3·3–4 mm. long, while the head is turned to one side (His). At a slightly later period the temporal and cervical flexures take place, and the hemispheres appear more prominently; the vitelline duct is narrowed, the position of the liver is indicated, while the limbs are still absent (His).

At the 21st day, the ovum is 13 mm. long, and the embryo 4–4·5 mm.; the umbilical vesicle 2·2 mm., and the intestine almost closed. Three branchial clefts, Wolffian bodies laid down, and the *first appearance of the limbs*, three cerebral vesicles, auditory capsules present (R. Wagner). Coste also observed, in addition, the nasal pits, eye, the opening for the mouth, with the frontal and superior maxillary processes, the heart with two ventricles and two auricles.

End of the 1st Month.—The embryos of 25–28 days are characterised by the distinctly stalked condition of the umbilical vesicle and the distinct presence of limbs. Size of the ovum, 17·6 mm.; embryo, 13 mm.; umbilical vesicle, 4·5 mm., with blood-vessels.

2nd Month.—The embryos of 28–35 days are more elongated, and all the branchial clefts are closed except the first. The allantois has now only three vessels, as the right umbilical vein is obliterated. At the 5th week, the nasal pits are united by furrows with the angle of the mouth, which close to form canals at the 6th week (Toldt). At 35–42 days the nasal and oral orifices are separated, the face is flat, the limbs show three divisions, the toes are not so sharply defined as the fingers. The outer ear appears as a low projection at the 7th week. The Wolffian bodies are much reduced in size.

End of the 2nd Month.—Ovum, 6½ cm.; villi, 1·3 mm. long; the circulation on the umbilical vesicle has disappeared; embryo, 26 mm. long, and weighs 4 grammes. Eyelids and nose present, umbilical cord 8 mm. long, abdominal cavity closed, ossification beginning in the lower jaw, clavicle, ribs, bodies of the vertebræ; sex indistinct, kidneys laid down.

3rd Month.—Ovum as large as a goose's egg, beginning of the placenta, embryo

7-9 cm., weighing 20 grammes, and is now spoken of as a *fœtus*. External ear well formed, umbilical cord 7 cm. long. Beginning of the difference between the sexes in the external genitals, umbilicus in the lower fourth of the linea alba.

4th Month.—Fœtus, 17 cm. long, weighing 120 grammes, sex distinct, hair and nails beginning to be formed, placenta weighs 80 grammes, umbilical cord 19 cm. long, umbilicus above the lowest fourth of the linea alba, contractions or movements of the limbs, meconium in the intestine, skin with blood-vessels shining through it, eyelids closed.

5th Month.—Fœtus, 18-27 cm., weighing 284 grammes; hair on the head and lanugo distinct; skin still somewhat red and thin, and covered with vernix caseosa (§ 287, 2), is less transparent; weight of placenta, 178 grammes; umbilical cord, 31 cm. long.

6th Month.—Fœtus, 28-34 cm., weighing 634 grammes; lanugo more abundant; vernix more abundant; testicles in the abdomen; pupillary membrane and eyelashes present; meconium in the large intestine.

7th Month.—Fœtus, 28-34 cm. long, weighing 1,218 grammes, the descent of the testicles begins—*one* testicle in the inguinal canal, the eyes open, the pupillary membrane often absorbed at its centre in the 28th week. In the brain other fissures are formed besides the primary ones. The fœtus is capable of living independently. At the beginning of this month, there is a centre of ossification in the os calcis.

8th Month.—Fœtus, 42 cm., weighing 1·5-2 kilos. (3·3-4·4 lbs.), hair of the head abundant, 1·3 cm. long, nails with a small margin, umbilicus below the middle of the linea alba, one testicle in the scrotum.

9th Month.—Fœtus, 47 cm., weighing 2½ kilos. (5·5 lbs.), and is not distinguishable from the child at the full period.

Fœtus at the Full Period.—Length of body, 51 cm. [20 inches], weight, 3¼ kilos. [7 lbs.], lanugo present only on the shoulders, skin white. The nails of the fingers project beyond the tips of the fingers, umbilicus slightly below the middle of the linea alba. The centre of ossification in the lower epiphysis of the femur is 4-8 mm. broad.

Period of Gestation or Incubation.

	Days.		Weeks.		Weeks.
Coluber,	12	Rat,	5	Lion,	14
Hen,	21	Guinea Pig,	7	Pig,	17
Duck,		Cat,	8	Sheep,	21
Goose,	29	Marten,		9	Goat,
Stork,	42	Dog,	10		Roe,
Cassowary,	65	Fox,		10	Bear,
Mouse,	24	Foumart,	Deer,		36-40
Rabbit,	32	Badger,	10	Woman,	40
Hare,		Wolf,			

Horse, Camel, 13 months; Rhinoceros, 18 months; and the Elephant, 24 months (Schenk).

Limitation of the supply of O to eggs, during incubation, leads to the formation of dwarf chicks.

447. Formation of the Osseous System.

Vertebral Column.—The ossification of the *vertebræ* begins at the 8th to the 9th week, and first of all, there is a centre in each vertebral arch, then a centre is

formed in the body behind the chorda (Robin), which, however, is composed of two closely apposed centres. At the 5th month, the osseous matter has reached the surface, the chorda within the body of the vertebra is compressed; the three parts unite in the 1st year. The atlas has one centre in the anterior arch and two in the posterior; they unite at the 3rd year. The epistropheus has a centre at the 1st year. The three points of the sacral vertebræ unite or ankylose between the 2nd and the 6th year, and all the vertebræ (sacral) become united to form one body between the 18th and 25th years. Each of the four coccygeal vertebræ has a centre from the 1st to 10th year. The vertebræ in later years produce 1-2 centres in each process; 1-2 centres in each transverse process; 1 in the mammillary process of the lumbar vertebræ; and 1 in each articular process (8-15 years). Of the upper and under surfaces of the body of a vertebra, each forms an epiphysial thin osseous plate, which may still be visible at the 20th year. Groups of the cells of the chorda are still to be found within the inter-vertebral discs. As long as the coccygeal vertebræ, the odontoid process, and the base of the skull are cartilaginous, they still contain the remains of the chorda (H. Müller). The coccygeal vertebræ form the tail, and they originally project in man like a tail (Fig. 474, IX, T), which is ultimately covered over by the growth of the soft parts (His).

The ribs bud out from the proto-vertebræ, and are represented on each vertebra. The thoracic ribs become cartilaginous in the 2nd month and grow forwards into the wall of the chest, whereby the 7 upper ones are united by a median portion (Rathke), which represents the position of one half of the sternum, and when the two halves meet in the middle line, the sternum is formed. When this does not occur, we have the condition of *cleft sternum*. At the 6th month, there is a centre of ossification in the manubrium, then 4-13 in pairs in the body, and 1 in the ensiform process. Each rib has a centre of ossification in its body at the 2nd month, and at the 8th to 14th, one in the tubercle and another in the head. These ankylose at the 14th-25th year. Sometimes cervical ribs are present in man, and they are largely developed in birds.

The skull.—The chorda extends forwards into the axial part of the base to the sphenoid bone. The skull at first is *membranous (primordial cranium)*; at the 2nd month, the basal portion becomes *cartilaginous*, including the occipital bone, except the upper half, the anterior and posterior part and wings of the sphenoid bone, the petrous part and mastoid process of the temporal bone, the ethmoid with the nasal septum, and the cartilaginous part of the nose. The other parts of the skull remain *membranous*, so that there is a cartilaginous and a membranous primordial cranium.

I. The **occipital bone** has a centre of ossification in the basilar part at the 3rd month, and one in the condyloid part and another in the fossa cerebelli, while there are two centres in the membranous cerebral fossæ. The four centres of the body unite during intra-uterine life. All the other parts unite at the 1st-2nd year.

II. The **post-sphenoid**.—From the 3rd month, it has two centres in the sella turcica, two in the sulcus caroticus, two in both great wings, which also form the lamina externa of the pterygoid process, while the non-cartilaginous and previously formed inner lamina arises from the superior maxillary process of the first branchial arch. During the first half of foetal life, these centres unite as far as the great wings; the dorsum sellæ and the clinoid process, as far as the synchondrosis sphenoid-occipitalis, are still cartilaginous, but they ossify at the 13th year.

III. The **pre-sphenoid** at the 8th month has two centres in the small wings and two in the body. At the 6th month they unite, but cartilage is still found within them even at the 13th year.

IV. The **ethmoid** has a centre in the labyrinth at the 5th month, then in the 1st year a centre in the central lamina. They unite about the 5th or 6th year.

V. Amongst the **membranous bones** are the inner lamina of the pterygoid process (one centre), the upper half of the tabular plate of the occipital (two points), the parietal bone (one centre in the parietal eminence), the frontal bone (one double centre in the frontal eminence), three small centres in the nasal spine, spina trochlearis and zygomatic process, nasal (one centre), the edges of the parietal bones (one centre), the tympanic ring (one centre), the lachrymal, vomer, and intermaxillary bone.

The **facial bones** are intimately related to the transformations of the *branchial arches* and *branchial clefts*. The median end of the **first branchial arch** projects inwards from each side towards the large oral aperture. It has two processes, the *superior maxillary process*, which grows more laterally towards the side of the mouth, and the *inferior maxillary process*, which surrounds the lower margin of the mouth (Fig. 474, IX). From above downwards there grows as an elongation of the basis cranii the *frontal process* (*s*), a broad process with a point (*y*) at its lower and outer angle, the inner nasal process. The frontal and the superior maxillary (*r*) processes unite with each other in such a way that the former projects between the two latter. At the same time there is ankylosed with the superior maxillary process, the small *external nasal process* (*n*), a prolongation of the lateral part of the skull, and lying above the superior maxillary process. Between the latter and the outer nasal process is a slit leading to the eye (*a*). Thus, the mouth is cut off from the nasal apertures which lie above it. But the separation is continued also within the mouth; the superior maxillary process produces the upper jaw, the nasal process, and the intermaxillary process (Goethe)—the latter is present in man, but is united to the upper jaw. The *intermaxillary bone*, which in many animals remains as a separate bone (*os incisivum*), carries the incisor teeth. At the 9th week the hard palate is closed, and on it rests the septum of the nose, descending vertically from the frontal process. The lower jaw is formed from the inferior maxillary process. At the circumference of the oral aperture the lips and the alveolar walls are formed. The tongue is formed behind the point of the union of the second and third branchial arches (His); while, according to Born, it is formed by an intermediate part between the inferior maxillary processes.

These transformations may be interrupted. If the frontal process remains separate from the superior maxillary processes, then the mouth is not separated from the nose. This separation may occur only in the soft parts, constituting *hare-lip* (Fig. 477), or it may involve the hard palate constituting *cleft palate*. Both conditions may occur on one or both sides.

From the posterior part of the first branchial arch are formed the *malleus* (ossified at the 4th month), and *Meckel's cartilage* (Fig. 478), which proceeds from the latter behind the tympanic ring as a long cartilaginous process, extending along the inner side of the lower jaw, almost to its middle. It disappears after the 6th month; still its posterior part forms the internal lateral ligament of the maxillary articulation. Near where it leaves the malleus is the *processus Folii* (Bau-müller). A part of its median end ossifies, and unites with the lower jaw. The lower jaw is laid down in membrane from the first branchial arch, while the angle and condyle are formed from a cartilaginous process. The union of both bones to form the chin occurs at the 1st year. From the superior maxillary process are formed the inner lamella of the pterygoid process, the palatine process of the upper jaw, and the palatine bone at the end of the 2nd month, and lastly the malar bone.

The **second arch** [*hyoid*], arising from the temporal bone, and running parallel

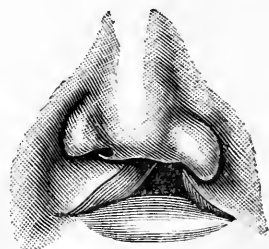

Fig. 477.

Hare-lip on the left side.

with the first arch, gives rise to the stapes (although, according to Salensky, this is derived from the first arch), the eminentia pyramidalis, with the stapedius muscle, the incus, the styloid process of the temporal bone, the (formerly cartilaginous) stylo-hyoid ligament, the smaller cornu of the hyoid bone, and lastly the glosso-palatine arch (His).

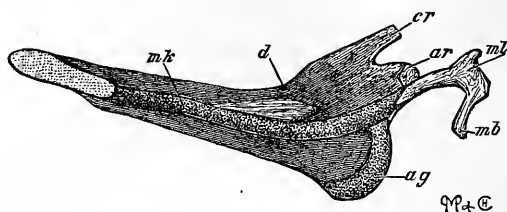

Fig. 478.

Inner view of the lower jaw of an embryo pig 3 inches long \times $3\frac{1}{2}$ —*mk*, Meckel's cartilage; *d*, dentary bone; *cr*, coronoid process; *ar*, articular process (condyle); *ag*, angular process; *ml*, malleus; *mb*, manubrium (W. K. Parker).

The **third arch** [*thyro-hyoid*] forms the greater cornu and body of the hyoid bone and the pharyngo-palatine arch (His).

The **fourth arch** gives rise to the thyroid cartilage (His).

Branchial Clefts.—The *first* branchial or visceral cleft is represented by the external auditory meatus, the tympanic cavity, and the Eustachian tube; all the other clefts close. Should one or other of the clefts remain open, a condition that is sometimes hereditary in some families, a *cervical fistula* results, and it may be formed either from without or within. Sometimes only a blind diverticulum remains. Branchiogenic tumours and cysts depend upon the branchial arches (R. Volkmann).

[Relation of Branchial Clefts to Nerves.—It is important to note that the clefts in front of the mouth (*pre-oral*), and those behind it (*post-oral*), have a relation to certain nerves. The *lachrymal* slit between the frontal and nasal processes is supplied by the *1st division of the trigeminus*. The *nasal slit* between the superior maxillary process and the nasal process is supplied by the bifurcation of the *3rd nerve*. The *oral cleft*, between the superior maxillary processes and the mandibular arch, is supplied by the *2nd and 3rd divisions of the trigeminus*. The first post-oral or tympanic-Eustachian cleft, between the mandibular arch (1st) and the hyoid arch is supplied by the *portio dura*. The next cleft is supplied by the *glosso-pharyngeal*, and the succeeding clefts by branches of the *vagus*.]

The **thymus** and **thyroid glands** are formed as paired diverticula from the epithelium, covering the branchial arches. The epithelium of the last two clefts does not disappear (pig), but proliferates and pushes inwards cylindrical processes, which develop into two epithelial vesicles, the paired commencement of the thyroid glands. These vesicles have at first a central slit, which communicates with the pharynx (Wölfler). According to His, the thyroid gland appears as an epithelial vesicle in the region of the 2nd pair of visceral arches in front of the tongue—in man at the 4th week. Solid buds, which ultimately become hollow, are given off from the cavity in the centre of the embryonic thyroid gland. The two glands ultimately unite together. The only epithelial part of the *thymus* which remains is the so-called concentric corpuscles (p. 212). According to Born, this gland is a diverticulum from the 3rd cleft, while His ascribes its origin to the 4th and 5th aortic arches in man at the 4th week. The *carotid gland* is of epithelial origin, being a variety of the thyroid (Stieda).

The Extremities.—The origin and course of the nerves of the brachial plexus

show that the *upper extremity* was originally placed much nearer to the cranium, while the position of the *posterior* pair corresponds to the last lumbar and the 3rd or 4th sacral vertebræ (His).

The **clavicle**, according to Bruch, is not a membrane bone, but is formed in cartilage like the furculum of birds (Gegenbaur). At the 2nd month it is four times as large as the upper limb; it is the first bone to ossify at the 7th week. At puberty a sternal epiphysis is formed. Episternal bones must be referred to the clavicles (Götte). Ruge regards pieces of cartilages existing between the clavicle and the sternum, as the analogues of the episternum of animals. The clavicle is absent in many mammals (carnivora); it is very large in flying animals, and in the rabbit is half membranous. The furculum of birds represents the united clavicles.

The **scapula** at first is united with the clavicle (Rathke, Götte), and at the end of the 2nd month it has a median centre of ossification, which rapidly extends. Morphologically, the accessory centre in the coracoid process is interesting; the latter also forms the upper part of the articular surface. In birds, the corresponding structure forms the *coracoid bone*, and is united with the sternum; while in man, only a membranous band stretches from the tip of the coracoid process to the sternum. The long, basal, osseous strip, corresponds to the *suprascapular bone* of many animals. The other centres of ossification are—one in the lower angle, two or three in the acromion, one in the articular surface, and an inconstant one in the spine. Complete consolidation occurs at puberty.

The **humerus** ossifies at the 8th to the 9th week in its shaft. The other centres are—one in the upper epiphysis, and one in the capitellum (1st year); one in the great tuberosity and one in the small tuberosity (2nd year); two in the condyles (5th–10th year); one in the trochlea (12th year). The epiphyses unite with the shaft at the 16th–20th year.

The **radius** ossifies in the shaft at the 3rd month. The other centres are—one in the lower epiphysis (5th year), one in the upper (6th year), and an inconstant one in the tuberosity, and one in the styloid process. They unite at puberty.

The **ulna** also ossifies in the shaft at the 3rd month. There is a centre in the lower end (6th year), two in the olecranon (11th–14th year), and an inconstant one in the coronoid process, and one in the styloid process. They consolidate at puberty.

The **carpus** is arranged in mammals in two rows. The *first* row contains 3 bones—the radial, intermediate, and ulnar bones. In man these are represented by the scaphoid, semilunar, and cuneiform bones; the pisiform is only a sesamoid bone in the tendon of the flexor carpi ulnaris. The *second* row really consists of as many bones as there are digits (*e.g.*, salamander). In man the common position of the 4th and 5th fingers is represented by the unciform bone.

Morphologically, it is interesting to observe that an *os centrale*, corresponding to the os carpale centrale of reptiles, amphibians, and some mammals, is formed at first, but disappears at the 3rd month, or unites with the scaphoid. Only in very rare cases is it persistent. All the carpal bones are cartilaginous at birth. They ossify as follows:—Os magnum, unciform (1st year), cuneiform (3rd year), trapezium, semilunar (5th year), scaphoid (6th year), trapezoid (7th year), and pisiform (12th year).

The **metacarpal bones** have a centre in their diaphyses at the end of the 3rd month, and so have the *phalanges*. All the phalanges and the first bone of the thumb have their cartilaginous epiphyses at the central end, and the other metacarpal bones at the peripheral end, so that the first bone of the thumb is to be regarded as a phalanx. The epiphyses of the metacarpal bones ossify at the 2nd, and those of the phalanges at the 3rd year. They consolidate at puberty.

The **innominate bone**, when cartilaginous, consists of two parts—the pubis and the ischium (Rosenberg). Ossification begins with three centres—one in the ilium (3rd to 4th month), one in the descending ramus of the ischium (4th to 5th

month), one in the horizontal ramus of the pubis (5th to 7th month). Between the 6th to the 14th year three centres are formed where the bodies of the three bones meet in the acetabulum, another in the superficies auricularis, and one in the symphysis. Other accessory centres are:—One in the anterior inferior spine, the crest of the ilium, the tuberosity and the spine of the ischium, the tuberculum pubis, eminentia ileopectinea, and floor of the acetabulum. At first, the descending ramus of the pubis and the ascending ramus of the ischium unite at the 7th–8th year; the Y-shaped suture in the acetabulum remains until puberty (Fig. 479).

The **femur** has its middle centre at the end of the 2nd month. At birth there is a centre in the lower epiphysis; slightly later in the head. In addition, there is one in the great trochanter (3rd to 11th year), one in the lesser trochanter (13th to 14th year), two in the condyles (4th to 8th year); all unite about the time of puberty. The *patella* is a sesamoid bone in the tendon of the quadriceps femoris. It is cartilaginous at the 2nd month, and ossifies from the 1st to the 3rd year.

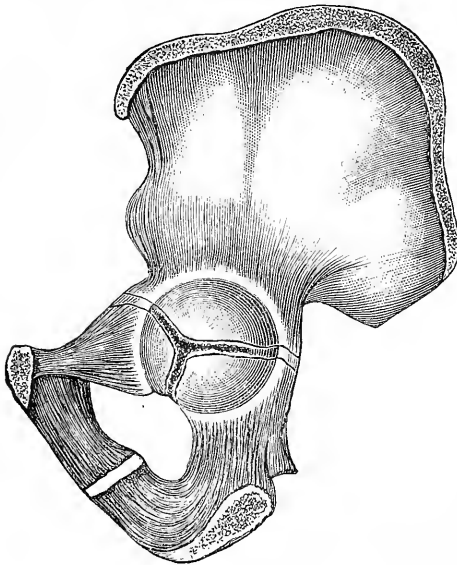

Fig. 479.

Centres of ossification of the innominate bone.

The **tarsus** generally resembles the carpus. The os calcis ossifies at the beginning of the 7th month, the astragalus at the beginning of the 8th month, the cuboid at the end of the 10th, the scaphoid (1st to 5th year), the I. and II. cuneiform (3rd year), and the III. cuneiform (4th year). An accessory centre is formed in the heel of the calcaneum at the 5th–10th year, which consolidates at puberty.

The **metatarsal bones** are formed like the metacarpals, only later.

[**Histogenesis of Bone.**—The great majority of our bones are laid down in cartilage, or are preceded by a cartilaginous stage, including the bones of the limbs, backbone, base of the skull, sternum, and ribs. These consist of solid masses of hyaline cartilage, covered by a membrane, which is identical with, and ultimately becomes, the periosteum. The formation of bone, when preceded by cartilage, is called *endochondral* bone. Some bones, such as the tabular bones of the vault of the cranium, the facial bones, and part of the lower jaw, are not preceded by cartilage. In the latter, there is merely a membrane present, while from and in it the future bone is formed. It becomes the future periosteum a well. This is called the *intra-membranous* or *periosteal* mode of formation.]

[**Endochondral Formation.**—(1.) The cartilage has the shape of the future bone only in miniature, and it is covered with periosteum. In the cartilage an opaque spot, or centre of ossification, appears, due to the deposition of lime-salts in its matrix. The cartilage cells proliferate in this area, but the first bone is formed under the periosteum in the shaft, so that an osseous case like a muff surrounds the cartilage. This bone is formed by the sub-periosteal *osteoblasts*. (2.) Blood-

vessels, accompanied by osteoblasts and connective-tissue, grow into the cartilage from the osteogenic layer of the periosteum (*periosteal processes* of Virchow), so that the cartilage becomes channelled and *vascular*. As these channels extend, they open into the already enlarged cartilage lacunæ, absorption of the matrix taking place, while other parts of the cartilaginous matrix become calcified. Thus a series of cavities, bounded by calcified cartilage—the *primary medullary cavities*—are formed. They contain the *primary or cartilage marrow*, consisting of blood-vessels, osteoblasts, and osteoclasts, carried in from the osteogenic layer of the periosteum, and, of course, the cartilage cells that have been liberated from their lacunæ. (3.) The osteoblasts are now in the interior of the cartilage, where they dispose themselves on the calcified cartilage and secrete or form around them an osseous matrix, thus enclosing the calcified cartilage, while the osteoblasts themselves become embedded in the products of their own activity and remain as *bone-corpuscles*. Bone, therefore, is at first spongy bone, and, as the primary medullary spaces gradually become filled up by new osseous matter, it becomes denser, while the calcified cartilage is gradually absorbed. It is to be remembered that, *pari passu* with the deposition of the new bone, bone and cartilage are being absorbed by the *osteoclasts*.]

Chemical Composition of Bone.—Dried bone contains $\frac{1}{3}$ of organic matter or *ossein*, from which gelatin can be extracted by prolonged boiling; and about $\frac{2}{3}$ mineral matter, which consists of neutral calcic phosphate, 57 per cent.; calcic carbonate, 7 per cent.; magnesian phosphate, 1–2 per cent.; calcic fluoride, 1 per cent., with traces of chlorine; and water, about 23 per cent. The *marrow* contains fluid fat, albumin, hypoxanthin, cholesterin, and extractives. The *red marrow* contains more iron, corresponding to its larger proportion of hæmoglobin (Nasse).

[The *medullary cavity* of a long bone is occupied by *yellow marrow*, which contains about 96 per cent. of fat. The *red marrow* occurs in the ends of long bones, in the flat bones of the skull, and in some short bones. It contains very little fat and is really lymphoid in its characters, being, in fact, a *blood-forming tissue* (p. 15).]

Growth of Bones.—Long bones grow in *thickness* by the deposition of new bone from the periosteum, the osteoblasts becoming embedded in the osseous matrix to form the *bone-corpuscles*. Some of the fibres of the connective-tissue which are caught up, as it were, in the process, remain as *Sharpey's fibres*, which are calcified fibres of white fibrous tissue, bolting together the peripheric lamellæ. [Müller and Schäfer have shown that there are also fibres in the peripheric lamellæ, comparable to yellow elastic fibres; they branch, stain deeply with magenta, and are best developed in the bones of birds.]

At the same time that bone is being deposited on the surface, it is being absorbed in the marrow cavity by the action of the *osteoclasts*, so that a metallic ring, placed round a bone in a young animal, ultimately comes to lie in the medullary cavity (Duhamel). The *growth in length* takes place by the continual growth and ossification of the epiphysial cartilage. The cartilage is gradually absorbed from below, but it proliferates at the same time, so that what is lost in one direction is more than made up in the other (J. Hunter).

When the growth of bone is at an end, the epiphysis becomes united to the diaphysis, the epiphysial cartilage itself becoming ossified. It is not definitely proved whether there is an interstitial expansion or growth of the true osseous substance itself, as maintained by Wolff (§ 244, 9).

Howship's Lacunæ.—The *osteoclasts* or myeloplaxes are large multinuclear giant-cells, which erode bone. They can be seen in great numbers lying in small depressions, corresponding to them—Howship's lacunæ—on the fang of a temporary tooth, when it is being absorbed. They are readily seen in a microscopical section of spongy bone with the soft parts preserved.]

The **form** of a bone is influenced by external conditions. The bones are

stronger, the greater the activity of the muscles acting on them. If pressure acting normally upon a bone be removed, the bone develops in the direction of least resistance, and becomes thicker in that direction. Bone develops more slowly on the side of the greatest external pressure, and it is curved by unilateral pressure (Lesshaft).

448. Development of the Vascular System.

Heart.—[The heart appears as a solid mass of cells in the splanchnopleure, at the front end of the embryo, immediately under the "fore-gut." Very soon a cavity appears in this mass of cells; some of the latter float free in the fluid, while the cellular wall begins to pulsate rhythmically. This hollow cellular structure elongates into a tube, which very soon assumes a shape somewhat like an S (Fig. 480, 1)], and there are indications of its being subdivided into (a) an upper aortic part with the *bulbus arteriosus*; (b) a middle or *ventricular part*, and (v) a lower, venous or *auricular part*. The heart then curves on itself in the form of a horse-shoe (2), so that the venous end (A) comes to lie above, and slightly behind, the arterial end. On the right and left side, respectively, of the venous part is a blind, hollow outgrowth, which forms the large auricle on each side (3, o, o₁). The flexure of the body of the heart corresponding to the great curvature (2, V) is divided into two large compartments (3), the division being indicated by a slight depression on the surface. The large *truncus venosus* (4, V), which joins with the middle of the posterior wall of the auricular part, is composed of the superior and inferior *venæ cavæ*. This common trunk is absorbed at a later period into the enlarging auricle, and thus arises the separate terminations of the superior and inferior *venæ cavæ*. In man, the heart soon comes to lie in a special cavity, which, in part, is bounded by a portion of the diaphragm (His). At the 4th-5th week, the heart begins to be divided into a right and a left half. Corresponding to the position of the vertical ventricular furrow, a septum grows upwards vertically in the interior of the heart, and divides the ventricular part into a right and left ventricle (5, R, L). There is a constriction in the heart, between the auricular and ventricular portions, forming the *canalis auricularis*. It contains a communication between the auricle and both ventricles, lying between an anterior and posterior projecting lip of endothelium, from which the auriculo-ventricular valves are formed (F. Schmidt). The ventricular septum grows upwards toward the *canalis auricularis*, and is complete at the 8th week. Thus, the large undivided auricle communicates by a right and left auriculo-ventricular opening with the corresponding ventricle (5). At the same time two septa (4, p a) appear in the interior of the *truncus arteriosus* (4, p), which ultimately meet, and thus divide this tube into two tubes (5, a p), the latter forming the aorta and pulmonary artery, and are disposed towards each other like the tubes in a double-barrelled gun. The septum grows downwards until it meets the ventricular septum (5), so that the right ventricle comes to be connected with the pulmonary artery, and the left with the aorta. The division of the *truncus arteriosus*, however, takes place only in the first part of its course. The division does not take place above, so that the pulmonary artery and aorta unite in one common trunk above. This communication between the pulmonary artery and the aorta, is the *ductus arteriosus Botalli* (7, B).

In the **auricle** a septum grows from the front and behind, ending internally with a concave margin. The *vena cava superior* (6, C_s) terminates to the right of this fold, so that its blood will tend to go towards the right ventricle, in the direction of the arrow in 6, x. The *cava inferior*, on the other hand (6, C_i), opens directly opposite the fold. On the left of its orifice, the valve of the *foramen ovale* is formed by a fold growing towards the auricular fold, so that the blood-current from the inferior *vena cava* goes only to the *left*, in the direction of the

arrow, *y*; on the right of the orifice of the cava, and opposite the fold, is the Eustachian valve, which, in conjunction with the tubercle of Lower (*tL*), directs

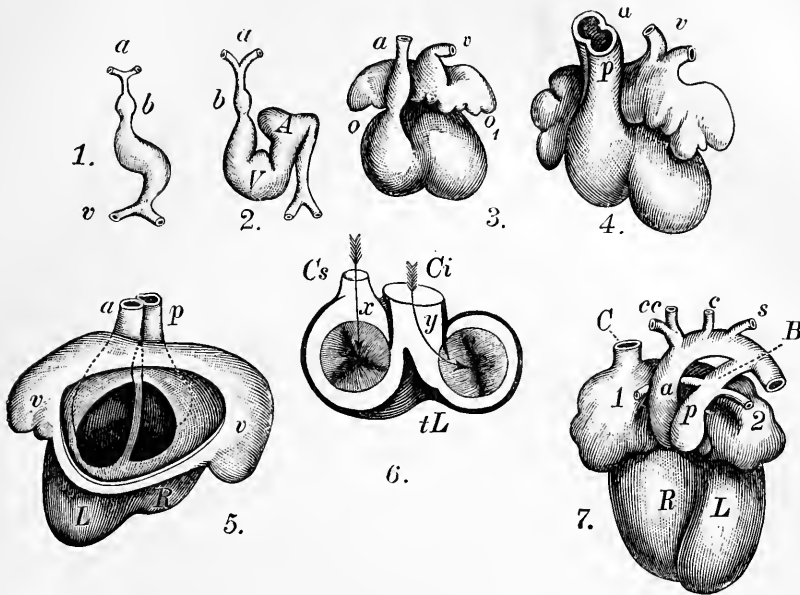

Fig. 480.

Development of the Heart—1, Early appearance of the heart; *a*, aortic part, with the bulbus, *b*; *v*, venous end. 2, Horse-shoe shaped curving of the heart—*a*, aortic end, with the bulbus, *b*; *V*, ventricle; *A*, auricular part. 3, Formation of the auricular appendages, *o*, *o*₁, and the external furrow in the ventricle. 4, Commencing division of the aorta, *p*, into two tubes, *a*. 5, View from behind of the opened auricle, *v*, *v*, into the, *L* and *R*, ventricles, and between the two latter the projecting ventricular septum, while the aorta (*a*) and pulmonary artery (*p*) open into their respective ventricles. 6, Relation of the orifices of the superior (*Cs*) and inferior vena cava (*Ci*) to the auricle, (schematic view from above)—*x*, direction of the blood of the superior vena cava into the right auricle; *y*, that of the inferior cava to the left auricle; *tL*, tubercle of Lower. 7, Heart of the ripe fœtus—*R*, right, *L*, left ventricle; *a*, aorta, with the innominate, *c*, *c*, carotid *c*, and left subclavian artery, *s*; *B*, ductus arteriosus; *p*, pulmonary artery, with the small branches, *1* and *2*, to the lungs.

the stream from the inferior vena cava to the left into the left auricle, through the pervious *foramen ovale*. Compare the fœtal circulation (p. 1138). **After birth**, the valve of the foramen ovale closes that aperture, while the ductus arteriosus also becomes impervious, so that the blood of the pulmonary artery is forced to go through the pulmonary branches proceeding to the expanding lungs. Sometimes the foramen ovale remains pervious, giving rise to serious symptoms after a time, and constituting *morbus ceruleus*.

Arteries.—With the formation of the branchial arches and clefts, the number of aortic arches on each side becomes increased to 5 (Fig. 481), which run above and below each branchial cleft, in a branchial arch, and then all reunite behind in a common descending trunk (2, *ad*) (Rathke). These blood-vessels remain only in animals that breathe by gills. In man, the upper two arches disappear com-

pletely (3). When the truncus arteriosus divides into the pulmonary artery and the aorta (4, *P*, *A*), the lowest arch on the left side, with its origin, forms the pulmonary artery (4), and it springs from the right side of the heart. Of these the

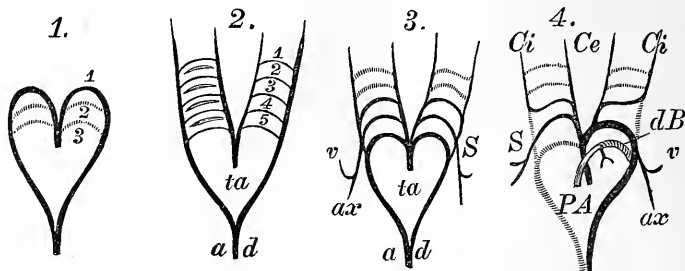

Fig. 481.

The aortic arches—1, The first position of the 1, 2, and 3 arches; 2, 5 aortic arches; *ta*, common aortic trunk; *ad*, descending aorta. 3, Disappearance of the upper two arches on each side—*S*, subclavian artery; *v*, vertebral artery; *ax*, axillary artery. 4, Transition to the final stage—*P*, pulmonary artery; *A*, aorta; *dB*, ductus arteriosus (Botalli); *S*, right subclavian, united with the right common carotid, which divides into the internal (*Ci*) and external carotid (*Ce*); *ax*, axillary; *v*, vertebral artery.

left lowest arch forms the *ductus arteriosus* (*dB*), and from the commencement of the latter proceed the pulmonary branches of the pulmonary artery. Of the remaining

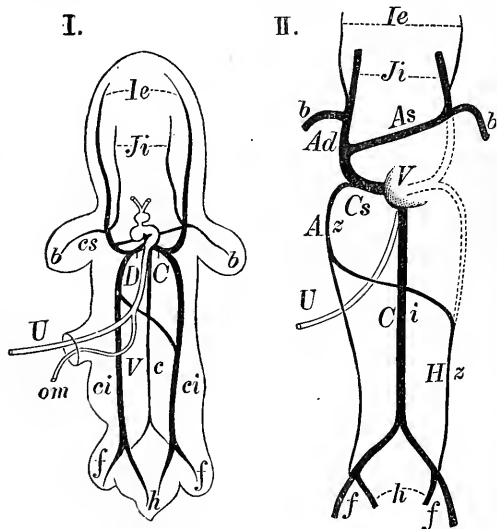

Fig. 482.

I. First appearance of the veins of the embryo.
II. Their transformations to form the final arrangement.

arches which are united with the aorta, the left middle one (*i.e.*, the fourth left) forms the permanent aortic arch into which the ductus arteriosus opens; while the right one (fourth) forms the subclavian artery, the third arch forms on each side the origin of the carotids (*Ci*, *Ce*). The arteries of the first and second circulations have been referred to already (p. 1130). When the umbilical vesicle, with its primary circulation, diminishes, only one omphalo-mesenteric artery is present, which gives a branch to the intestine. At a later period, the omphalo-mesenteric arteries atrophy, while the artery to the intestine—the superior mesenteric—becomes the largest of all, it being originally derived from one of the omphalo-mesenteric arteries.

Veins of the Body.—The veins first formed in the *body of the embryo itself* are the two *cardinal veins*; on each side an anterior (Fig. 482, I, *cs*), and a posterior

(*c i*—Rathke), which proceed towards the heart and unite on each side to form a large trunk, the *duct of Cuvier* (D C), which passes into the venous part of the heart. The anterior cardinal veins give off; the subclavian veins (*b b*) and the common jugular veins, which divide into the external (I *e*) and internal (J *i*) jugular veins. In addition, there is a *transverse anastomosing branch* passing obliquely from the left (where it divides) to the right, which joins their trunk lower down. In the final arrangement (II), this anastomosis (A *s*) becomes very large to form the *left innominate vein*, while, with the growth of the arms, the subclavian veins increase (*b b*); and, lastly, the calibre of the jugular veins changes, the internal jugular (J *i*) becoming very large, and the external jugular (I *e*) smaller. In some animals—*e.g.*, the dog and rabbit—the large embryonic size is retained. The part of the left superior cardinal vein, from the anastomosis downwards to the left duct of Cuvier, disappears. The *posterior cardinal veins* divide in the pelvis into the hypogastric (I, *h*) and external iliac (*f.f*). The inferior cava at first is very small (I, V *c*), divides at the entrance to the pelvis, and on each side goes into the point of division of the cardinal veins. There is also a transverse ascending anastomosis between the right and left cardinal veins. For the final arrangement, the cava inferior (II, C *i*) dilates, and with it the hypogastric and external iliac vein on each side. The right cardinal vein remains very small (*Vena azygos*, A *z*), and also the lower part from the left one to the transverse anastomosis. The latter itself also remains very small (*Vena hemiazygos*, H *z*). On the other hand, the upper part above the anastomosis to the duct of Cuvier disappears. Lastly, the common large venous trunk is so absorbed into the wall of the auricle (V) that both *venæ cavæ* have each a separate orifice (p. 1148). The embryonic condition of the veins persists in fishes.

Veins of the First and Second Circulation, and Formation of the Portal System.—The two omphalo-mesenteric veins (*om*, *om*₁) open into the posterior or venous end of the tubular heart (Fig. 483, I, H). The right vein, however, disappears very soon. As soon as the allantois is formed, the two umbilical veins

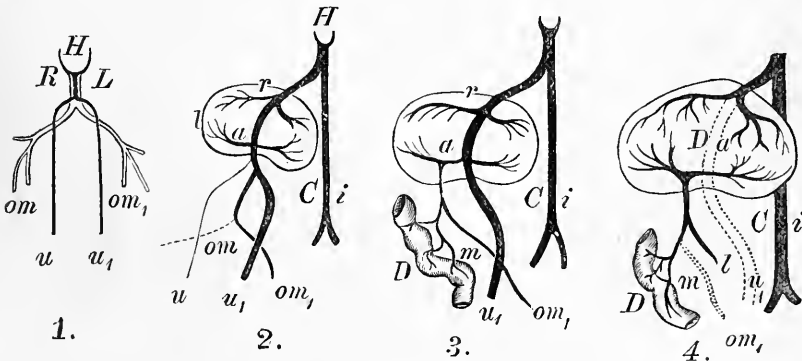

Fig. 483.

Development of the veins and portal system—H, heart; R, L, right and left side of the body; *om*, right omphalo-mesenteric vein; *om*₁, left, *u*, right umbilical vein; *u*₁, left; C *i*, vena cava inferior; *a*, *venæ advehentes*; *r*, *venæ revehentes*; D, intestine; *m*, mesenteric vein; 4, *l*, splenic vein; 2, *l*, liver.

join the truncus venosus (1, *u u*₁). At first, the omphalo-mesenteric veins are larger than the umbilical veins; at a later period this is reversed, and the right umbilical vein disappears. As soon as veins are formed within the body proper of the embryo, the inferior cava also opens into the truncus venosus (2, C *i*). Gradually, the umbilical vein (2, *u*₁) becomes the chief trunk, while the small omphalo-mesenteric (2, *om*₁) carries little blood.

Portal System.—The umbilical and omphalo-mesenteric veins pass in part directly under the liver to reach the heart. They send branches—carrying arterial blood—to the liver, and the latter grows round these vessels. These branches are the *venæ advehentes* (2 and 3, *a*). The blood circulating through the liver from the *venæ advehentes* is returned by other veins, the *venæ revehentes* (2 and 3, *r*), which reunite at the blunt margin of the liver with the chief trunk of the umbilical vein. The umbilical vein (3, u_1) and the omphalo-mesenteric vein (3, $o m_1$) anastomose in the liver. When the intestine develops (3, II), the mesenteric vein (*m*) opens into the omphalo-mesenteric vein, and the splenic vein as well (4, I), when the spleen is formed. When the omphalo-mesenteric vein (4, $o m_1$) at a later period disappears, the vein from the intestine now becomes the common trunk of the previously united vessels. It unites in the liver with the umbilical vein to form the trunk of the *vena portæ*. When, after birth, the umbilical vein disappears (4, u_1), the mesenteric alone remains as the *portal vein*. As the *ductus venosus* is obliterated, the portal vein must send its blood through the liver, and thus the portal circulation is completed.

449. Formation of the Intestinal Canal.

The **primitive intestine**, or gut, consists of a straight tube proceeding from the head to the tail. The vitelline duct is inserted at that point, which at a later period corresponds to the lower part of the ileum. At the 4th week the tube makes a slight bend toward the umbilicus (Fig. 484, I). As already mentioned, the **vitelline duct** is obliterated, remaining only for a time as a thread attached to the intestine, being still visible at the 3rd month. Sometimes it remains as a short blind tube communicating with the intestine. This is the so-called "*true intestinal diverticulum*;" occasionally a cord—the obliterated omphalo-mesenteric vessels—passes from it to the umbilicus. In very rare cases the duct may remain open as far as the umbilicus, forming a congenital fistula of the ileum, or it may

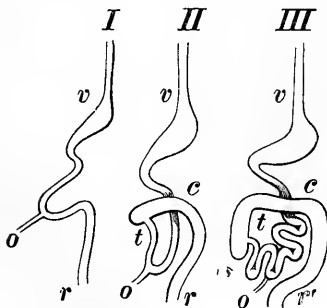

Fig. 484.

Development of the intestine—*v*, Stomach; *o*, insertion of the vitelline duct; *t*, small intestine; *c*, colon; *r*, rectum.

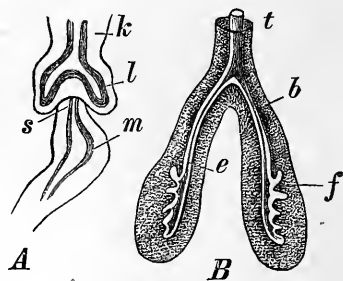

Fig. 485.

Formation of the lungs: A, Diverticula of the lungs as double sacs—*k*, mesoblastic layer; *l*, hypoblastic layer; *m*, stomach; *s*, oesophagus. B, Further branching of the lungs—*t*, trachea; *b*, *e*, bronchi; *f*, projecting vesicles.

give rise to cystic formations (M. Roth). In a human foetus at the 4th week, His distinguished the cavity of the mouth, pharynx, oesophagus, stomach, duodenum, mesenteric intestine, and the hind-gut, with the cloaca. The intestine

then forms the *first coil* (Fig. 484, II) by rotating on itself at the intestinal umbilicus, so that the lower part of the intestine lying next the knee-like bend comes to lie above, while the upper part lies below. From the lower part of this loop the coils of the *small intestine* (III, *t*), which gradually grows longer. From the upper limb of the loop, which also elongates, the *large intestine* is formed; first the descending colon, then by elongation the transverse colon, and lastly, the ascending colon.

Glands.—By *diverticula*, or protrusions from the intestine, the various glands are formed. The cells of the hypoblast proliferate, and take part in the process as they form the secretory cells of the glands, while the mesoblastic part of the splanchnopleure forms the membranes of the glands, giving them their form. The diverticula are as follows:—

1. The **salivary glands**, which grow out from the oral cavity at first as simple solid buds, but afterwards become hollow and branched. [The salivary glands are developed from the epiblast lining the mouth (stomodæum).]

2. The **lungs**, which arise as two separate hollow buds (Fig. 485, A, 1), and ultimately have only one common duct, are protrusions from the œsophagus. The upper part of the united tracheal tube forms the larynx. The epiglottis and the thyroid cartilage originate from the part which forms the tongue (Ganghofner). The two hollow spheres grow and ramify like branched tubular glands with hollow processes (B, *f*). In the first period of development there is no essential difference between the epithelium of the bronchi and that of the primitive air-vesicles (Stieda). The spleen and suprarenal capsules, however, are not developed in this way. The former arises in a fold of the mesogastrium (His) at the 2nd month; the latter are originally larger than the kidneys.

3. The **pancreas** arises in the same way as the salivary glands, but is not visible at the 4th week (His).

4. The **liver** begins very early, and appears as a diverticulum, with two hollow *primitive hepatic ducts*, which branch and form bile ducts. At their periphery they penetrate between the solid masses of cells—the liver cells—which are derived from the hypoblast. At the 2nd month the liver is a large organ, and secretes at the 3rd month (§ 182).

5. In birds two small blind sacs are formed from the hind-gut.

6. The fetal respiratory organ, the *allantois*, is treated of specially (§ 444).

Peritoneum and Mesentery.—The inner surface of the *coelom*, or body cavity, the surface of the intestine, and its mesentery are covered by a serous coat—the *peritoneum*. At first the simple intestine is contained in a fold, or duplicature of the peritoneum; on the stomach, which is merely at first a spindle-shaped dilatation of the tube placed vertically, it is called mesogastrium. Afterwards, the stomach turns on its side, so that the left surface is directed forwards and the right backwards. Thus, the insertion of the mesogastrium, which originally was directed backwards (to the vertebral column), is directed to the left; the line of insertion forming the region of the great curvature, which becomes still more curved. From the great curvature the mesogastrium becomes elongated like a pouch (Fig. 486, I and II, *s*, *i*), constituting the omental sac, which extends so far downwards as to pass over the transverse colon and the loops of the small intestine (III, N). As the mesogastrium originally consists of two plates, of course the omentum must consist of four plates. At the 4th month the posterior surface of the omental sac unites with the surface of the transverse colon (Joh. Müller).

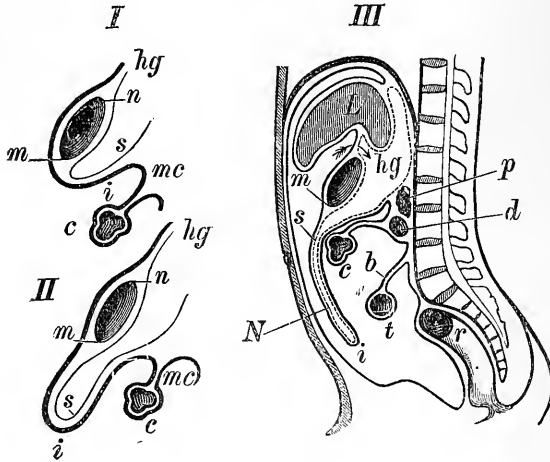

Fig. 486.

Formation of the omentum: I and II—*hg*, Gastro-hepatic ligament; *m*, great, *n*, lesser curvature of the stomach; *s*, posterior, and *i*, anterior fold or plate of the omentum; *mc*, mesocolon; *c*, colon. III—*L*, Liver; *t*, small intestine; *b*, mesentery; *p*, pancreas; *d*, duodenum; *r*, rectum; *N*, great omentum.

450. Development of the Urinary and Generative Organs.

Urinary Apparatus.—The first indication of this apparatus occurs in the chick at the 2nd day, and in the rabbit at the 9th, as the ducts of the *primitive kidneys* or *Wolffian ducts* (Fig. 487, I, W), which are formed from some cells mapped off from the lateral plate, above and to the side of the protovertebræ, and extending from the fifth to the last vertebra. The ducts are solid at first, but soon become hollow, and from their cavities there extend laterally a series of small tubes, which in the chick communicate freely with the peritoneal cavity (Kölliker). Into one end of each of these tubes grows a tuft of blood-vessels forming a structure resembling the glomerulus of the kidney. The tubes elongate, form convolutions, and increase in number. The upper end of the Wolffian duct is closed at first, its lower end, which lies in a projecting fold—the *plica urogenitalis* of Waldeyer—in the peritoneal cavity, opens into the uro-genital sinus. Close above the orifice of the Wolffian duct, appears the ureter as the duct of the kidney. The duct elongates, and branches at its upper end. Each canal at its end is like a stalked caoutchouc sac (Toldt), and into it there grows the already formed glomerulus. The duct of the kidney opens independently into the uro-genital sinus, and forms the *ureter*. The part where the branching of the duct stops forms the pelvis of the kidney, and the branches themselves the renal tubules. Toldt found Malpighian corpuscles in the human kidney at the 2nd month, and Henle's loops at the 4th. The first appearance of the *urinary bladder* is at the 4th week (His), and is more distinct at the 2nd month, as the dilated first part of the allantois (Fig. 487, 4, *a*). The upper part of the allantois remains as the obliterated *wrachus*, in the middle vesical ligament.

Internal Reproductive Organs.—In front of and internal to the Wolffian bodies, there arises in the mesoblast, the elongated reproductive gland or mass of *germ-epithelium* (Fig. 487, I, D), which in both sexes is originally alike. In addition, there is formed a canal or duct parallel to the Wolffian duct (W), which also opens into the uro-genital sinus; this is *Müller's duct* (M). The elevation of the future reproductive gland is covered originally by germ-epithelium (Waldeyer). The upper end of the Müllerian duct opens free into the abdominal cavity, while the lower ends of both ducts unite for a distance. Some of the germinal cells covering the surface of the future ovary enlarge to form ova, and sink into the stroma to form ova embedded in their Graafian follicles (p. 1108). In the *female*, the Müllerian ducts form the Fallopian tube (II, T), and the lower united ends the uterus.

In the *male* the germ-epithelium is not so tall. According to Waldeyer, there are two kinds of tubes in the Wolffian bodies, and some of these penetrate the position of the reproductive gland. These tubes, which are connected with the Wolffian ducts, become the seminiferous tubules (v. Wittich), and the Wolffian duct itself becomes the vas deferens, with the vesiculæ seminales. According to some other observers, however, tubes, which become the seminiferous tubules, are developed within the reproductive gland itself, and these tubes, lined with their germ-epithelium, ultimately form a connection with the Wolffian ducts.

The **Müllerian ducts**, which are really the ducts of the reproductive glands, disappear in man, all except the lowest part, which becomes the male uterus or vesicula prostatica (III, *u*)—the homologue of the uterus. The upper tubules of the Wolffian body unite at the 3rd month with the reproductive gland (which has

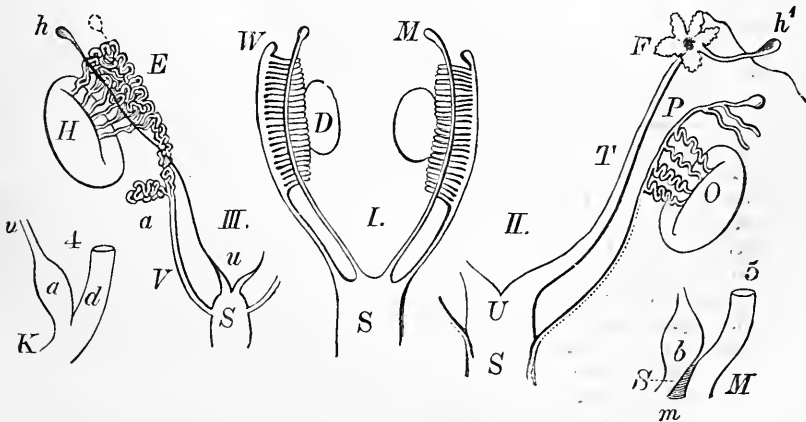

Fig. 487.

Development of the internal generative organs: I, Undifferentiated condition—D, reproductive gland, lying on the tubules of the Wolffian body; W, Wolffian duct; M, Müllerian duct; S, uro-genital sinus. II, Transformations in the female—F, fimbria, with the hydatid, *h'*; T, Fallopian tube; U, uterus; S, uro-genital sinus; O, ovary; P, parovarium. III, Transformations in the male—H, testis; E, epididymis, with the hydatid, *h*; *a*, vas aberrans; V, vas deferens; S, uro-genital sinus; *u*, male uterus; 4, *d*, hind-gut; *a*, allantois; *u*, urachus; K, cloaca; 5, M, rectum; *m*, perineum; *b*, position of the bladder; S, uro-genital sinus.

now become the body of the testis, and become the coni vasculosi of the epididymis, which are lined by ciliated epithelium (E); the remainder of the Wolffian

body disappears. Some detached tubules form the vasa aberrantia (*a*) of the testicle (Kobelt). The hydatid of Morgagni (*h*), at the head of the epididymis, according to Luschka and others, is a part of the epididymis—Fleischl regards it as the rudiment of the male ovary. The organ of Giraldès is part of the Wolffian body. The Wolffian duct itself becomes the vas deferens (*V*) from which the vesiculæ seminales are developed. The two Wolffian and two Müllerian ducts, as they enter the pelvis, are grouped together to form a common cord—the *genital cord*.

In the **female** the tubes of the Wolffian bodies disappear, all except a few tubules, lined with ciliated epithelium, constituting the *parovarium*, or organ of Rosenmüller (Fig. 468), and a part analogous to the organ of Giraldès in the broad ligament of the uterus (Waldeyer—Fig. 487, P). The same is the case with the Wolffian ducts. In some animals (ruminants, pig, cat, and fox) they remain permanently as the *ducts of Gaertner*.

The Müllerian duct is frayed out at its upper end to form the fimbriæ of the Fallopian tube, and it is often provided with a hydatid (*h*¹). That part of the uro-genital sinus into which the four ducts open grows above into a hollow sphere, which forms the vagina (Rathke). According to Thiersch and Leuckart, however, the two Müllerian ducts unite at their lower ends to form the united uterus (*U*) and vagina, while their free upper ends form the Fallopian tubes (*T*). The Müllerian ducts at first open into the posterior part of the urinary bladder below the ureters (uro-genital sinus, *S*), while ultimately this part of the bladder becomes so elongated posteriorly that the vagina (the united Müllerian ducts) and the urethra are united below and deeply within the vestibule of the vagina. At the 3rd to the 4th month, the uterus and vagina are not separate from each other, but at the 5th-6th month, the uterus is defined from the vagina.

The **testicles** lie originally in the lumbar region of the abdominal cavity (Fig. 488, *V t*), and are carried by a fold of the peritoneum—the mesorchium (*m*). From the hilum of the testicle a cord, the *gubernaculum testis*, runs through the inguinal canal into the base of the scrotum. At the same time a septum-like process is developed independently from the peritoneum to the base of the scrotum (*pv*). The testicle passes through the inguinal canal into the scrotum, but the mechanism and cause of the descent are not accurately ascertained—[*Descent*, p. 1141].

The **ovaries** also descend somewhat. The round ligament of the uterus corresponds to the gubernaculum testis. A process of the peritoneum passes in the female into the inguinal canal, as Nuck's canal. It is rare to find the ovaries descending into the labia majora.

[The origin of the urinary and generative organs is undoubtedly associated with the development of the Wolffian bodies. The researches of Semper and Balfour on elasmobranch fishes show that the process is a very complex one. There is a mass of cells on each side of the vertebral column, which is divided into three parts, the first called the *pronephros*, or head-kidney of Balfour and Sedgwick, the middle one, the *mesonephros*, or Wolffian body, and the posterior one, or *metanephros*, which is formed after the other two, gives origin to the permanent kidney in the amniota. The Müllerian duct is connected with the pronephros, the Wolffian duct with the mesonephros, and the ureter to the metanephros.]

[The following table, modified from Quain, shows the destiny of these structures:—

MÜLLERIAN DUCTS.

(Ducts of the Pronephros.)

<i>Female.</i>	<i>Male.</i>
Fallopian tubes.	Hydatid of Morgagni.
Hydatid.	Male uterus.
Uterus and vagina.	

WOLFFIAN BODIES (MESONEPHROS).

Parovarium.	Vasa efferentia, Coni vasculosi.
Paroophoron.	Organ of Giralès, Vasa aberrantia.
Round ligament of the uterus.	Gubernaculum testis.

WOLFFIAN DUCTS.

Chief tube of parovarium.	Convolted tube of epididymis.
Ducts of Gaertner.	Vas deferens and vesiculæ seminales.

METANEPHROS.

Kidney.
Ureter.]

The external genitals are at first not distinguishable in the two sexes (Fig. 488, I). At the 4th week there is merely a hole at the posterior extremity of the trunk, representing both the anus and the opening of the urachus, and forming a *cloaca* (Fig. 487, 4, K). In front of this, an elevation—the *genital eminence*—appears about the 6th week, and on each side of the orifice a large cutaneous elevation (II, *w*). At the end of the 2nd month there is a groove on the under surface of the genital eminence, leading back to the cloaca, and with distinct walls bounding it (II, *r*). At the middle of the 3rd month, the cloacal opening is divided by the growth of the perineum, between the urachus (now become the urinary bladder—Fig. 487, 5, *b*) and the rectum (M).

In the **male** the genital eminence enlarges, its groove deepens from the opening of the bladder onwards to the apex of the elevation, at the 10th week. The two edges unite to enclose the groove which becomes the urethra. When this does not take place, *hypospadias* occurs. At the 4th month, the glans, and at the 6th, the prepuce, are formed. The large cutaneous folds meet in the middle line or raphe to form the scrotum.

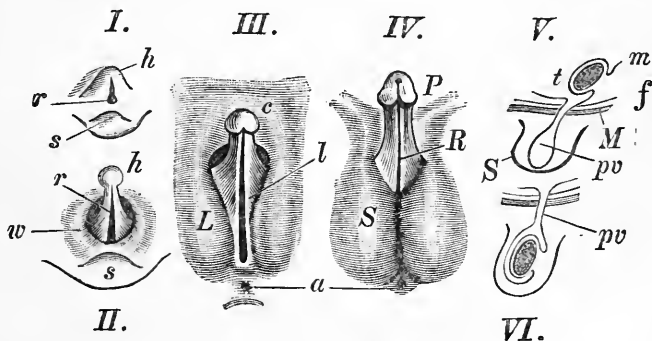

Fig. 488.

Development of the external genitals—I. and II., Genital eminence; *r*, genital groove; *s*, coccyx; *w*, cutaneous elevations. IV., *P*, Penis; *R*, raphe penis; *S*, scrotum. III., *c*, Clitoris; *l*, labia minora; *L*, labia majora; *a*, anus. V. and VI., Descent of the testicle; *t*, testis; *m*, mesorchium; *pv*, processus vaginalis of the peritoneum; *M*, abdominal wall; *S*, scrotum.

In the **female** the undifferentiated condition remains to a certain extent permanent. The small genital eminence remains as the *clitoris*, the margins of its furrow become the *nymphae*, the cutaneous elevations remain separate to form the *labia majora*. The uro-genital sinus remains short as the vestibule of the vagina, while

in man, by the closing of the genital groove, it has a long additional tube, the urethra.

[The following illustrations, after Schröder, show the changes of the external organs of generation in the female. In the early period (6th week) the hind-gut (Fig. 489, R), allantois (ALL), and the Müllerian ducts (M) communicate, but not with the exterior. About the 10th week a depression or

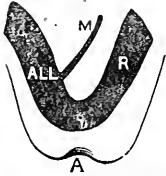

Fig. 489.

R, rectum continuous with the allantois (ALL—bladder); M, duct of Müller (vagina); A, depression of skin below genital eminence, which grows inwards to form the vulva (after Schröder).



Fig. 490.

The depression has extended onwards, and become continuous with the rectum and allantois, to form the cloaca (CL).

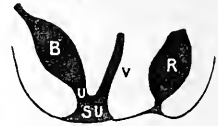

Fig. 491.

The cloaca is becoming divided into urogenital sinus (SU) and anus by the downward growth of the perineal septum. The ducts of Müller are united to form the vagina (V).

inflection of the skin takes place, *genital cleft*, until it meets the hind-gut and allantois, whereby the cloaca (Fig. 490, CL) is formed. The cloaca is then divided into an anterior part, the *uro-genital sinus*, into which the Müllerian ducts open, and a posterior part, the anus. There is a downward growth of the tissue between the hind-gut and the allantois to form the perineum (Fig. 491). The uro-genital

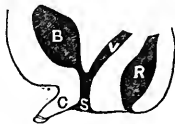

Fig. 492.

Perineum completely formed.



Fig. 493.

The upper part of the urogenital sinus has contracted into the urethra; the lower part persists as the vestibule (SV).

sinus then contracts at its upper part to form the short urethra, its lower part remaining as the vestibule (Fig. 492, SV), while the vagina has been formed by the union of the lower parts of the two Müllerian ducts. The bladder (B) is the expanded lower end of the stalk of the allantois.]

The causes of the difference of sex are by no means well known. From a statistical analysis of 80,000 cases, the influence of the age of the parents has been shown by Hofacker and Sadler. If the husband is younger than the wife, there are as many boys as girls; if both are of the same age, there are 1,029 boys to 1,000 girls; if the husband is older, 1,057 boys to 1,000 girls. In insects, food has a most important influence. Pflüger's investigations on frogs show that all

external conditions during development are without effect on the determination of the sex, so that the latter would seem to be determined before impregnation.

451. Formation of the Central Nervous System.

Fore-brain.—At each side of the fore-brain, or anterior cerebral vesicle, which is covered externally by epiblast and internally by the ependyma, there grows out a large stalked hollow vesicle, the rudiment of the *cerebral hemispheres*. The relatively wide opening in the stalk, or communication, ultimately becomes very small, and is the foramen of Monro. The middle part between the two cerebral vesicles remains small, and is the *'tween* or *inter-brain* with the 3rd ventricle in its interior. It elongates at the 2nd month towards the base of the brain as a funnel-shaped projection, to form the tuber cinereum with the infundibulum. The thalami optici, projecting and enlarging from the sides of the 3rd ventricle, narrow the foramen of Monro to a semilunar slit. At the base of the brain are formed, in the 2nd month, the corpora albicantia, at the 3rd the chiasma; while, within the 3rd ventricle, the commissures are formed. The *hypophysis*, belonging to the mid-brain, is a diverticulum of the nasal mucous membrane, extending through the base of the skull towards the hollow infundibulum, which grows to meet it. The choroid plexus, which grows into the ventricles of the hemispheres through the foramen of Monro, is a vascular development of the ependyma. At the 4th month, the *conarium* (pineal gland) is formed, and at this time the corpora quadrigemina cover the hemispheres. The *corpora striata* begin to be developed in the cerebral (lateral) ventricles at the 2nd month, while the cornu ammonis is formed at the 4th month. At the 3rd month the Sylvian fissure is formed, and the basis of the Island of Reil. The permanent cerebral convolutions are formed from the 7th month onwards.

The **mid-brain** or middle cerebral vesicle is gradually covered over by the backward growth of the hemispheres; its cavity forms the *aqueduct of Sylvius*. Depressions appear on the surface of the vesicle to divide it into four, the *corpora quadrigemina*, the longitudinal depression being formed at the 3rd, and the transverse one at the 7th month. The *cerebral peduncle* is formed by a thickening in the base of this vesicle.

In the **hind-brain** are formed the cerebellar hemispheres, which grow backwards to meet in the middle line. The vermes is formed at the 7th month. The cerebellum covers in the part of the medullary tube lying below it, and which is not closed, as far as the calamus. The *pons* arises in the floor of the hind-brain at the 3rd month.

The spindle-shaped, narrow **after-brain** forms the medulla oblongata, with the opening of the medullary tube in its upper part.

[The following table, from Quain, shows the destiny of each cerebral vesicle:—

I. Anterior Primary Vesicle,	{	1. <i>Prosencephalon</i> , (fore-brain)	}	Cerebral hemispheres, corpora striata, corpus callosum, fornix, lateral ventricles, olfactory bulb.
		2. <i>Thalamencephalon</i> , (inter or 'tween brain)		Thalami optici, pineal gland, pituitary body, third ventricle, optic nerve (primarily).
II. Middle Primary Vesicle,	{	3. <i>Mesencephalon</i> , (mid-brain)	}	Corpora quadrigemina, crura cerebri, aqueduct of Sylvius, optic nerve (secondarily).

III. Posterior Primary Vesicle, . . .	}	4. <i>Ependecephalon</i> , . . . (hind-brain)	{ Cerebellum, pons, anterior part of the fourth ven- tricle.
		5. <i>Metencephalon</i> , . . . (after-brain)	{ Medulla oblongata, fourth ventricle, auditory nerve.]

Spinal Cord.—The spinal cord is developed from the medullary tube behind the medulla oblongata, first the grey matter around the canal, while the white matter is added afterwards outside this. The ganglionic cells increase by division in amphibians (Lominsky). At first the spinal cord reaches to the coccyx. The first muscles are formed in the back at the 2nd month; at the 4th month they are red. The *spinal ganglia* are formed from a special strip of cells, and they are seen at the 4th week, and so are the anterior spinal roots, and some of the trunks of the spinal nerves, while the posterior roots are still absent. The peripheral nerves grow out from the ganglia of the spinal cord (first the motor and afterwards the sensory nerves), and penetrate into the other parts of the body (His). At first they are devoid of myelin.

452. Development of the Sense Organs.

Eye.—The primary optic vesicle grows out from the fore-brain towards the outer covering of the head or epiblast, and soon becomes folded in on itself (4th week), so that the stalked optic vesicle is shaped like an egg-cup (Fig. 494, I). The cavity in the interior of this cup is called the *secondary optic vesicle*. The inflected part becomes the retina (IV., *r*), while the posterior part becomes the choroidal epithelium (IV., *p*). The stalk becomes the optic nerve. At the under surface of the depression there is a slit—the *choroidal fissure*—which permits some

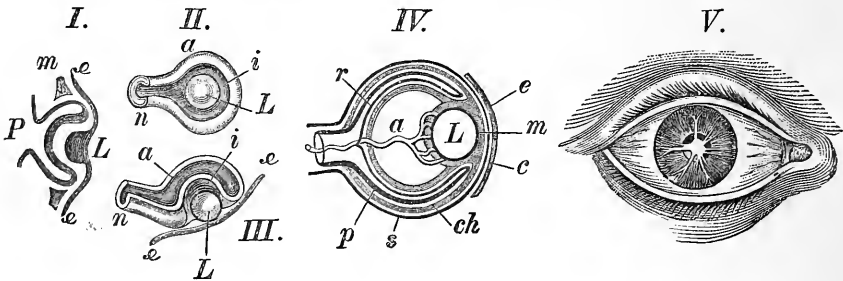

Fig. 494.

Development of the eye: I., Inflexion of the sac of the lens (L) into the primary optic vesicle (P)—*e*, epidermis; *m*, mesoblast. II., The inflexion seen from below—*n*, optic nerve; *e*, the outer, *i*, the inner, layer of the inflected vesicle; L, lens. III., Longitudinal section of II. IV., Further development—*e*, corneal epithelium; *c*, cornea; *m*, membrana capsulo-pupillaris; L, lens; *a*, central artery of the retina; *s*, sclerotic; *ch*, choroid; *p*, pigment layer of the retina; *r*, retina. V., Persistent remains of the pupillary membrane.

of the mesoblast to gain access to the interior of the eye. This slit forms the *coloboma* (II.); it is prolonged backward on the stalk, and contains the central artery of the retina. The margins of the coloboma afterwards unite completely

with each other, but in some rare conditions this does not take place, in which case we have to deal with a coloboma of the choroid or retina, as the case may be. In the bird, the embryonic coloboma slit does not close up, but a vascular process of the mesoblast dips into it, and passes into the eye to form the *pecten* (p. 1041—Lieberkühn). The same is the case in fishes where there is a large vascular process of the meso- and epiblast forming the *processus falciformis* (p. 1041).

The depression or inflexion of the optic vesicle is due to the downgrowth into it of a thickening of the epiblast (I., L). It is hollow, and as it grows inwards ultimately becomes spherical and separated from the epiblast to form the *crystalline lens*, so that the lens is epiblastic in its origin, while the capsule of the lens is a cuticular structure formed from epiblast. That part of the epiblast which covers the vesicle in front of the lens ultimately becomes the stratified epithelium of the cornea. The cornea is formed at the 6th week. The substance of the choroid, sclerotic, and cornea is formed around the position of the eye from the mesoblast (*m*). The capsule of the lens is at first completely surrounded by a vascular membrane—the *membrana capsulo-pupillaris*. Afterwards, the lens passes more posteriorly into the eye—the anterior part of the capsulo-papillary membrane, however, remains in the anterior part of the eye, while towards it grows the margin of the iris (7th week), so that the pupil is closed by this part of the vascular capsule (*membrana pupillaris*). The blood-vessels of the iris are continuous with those of the pupillary membrane; those of the posterior capsule of the lens give off the hyaloid artery, a continuation of the central artery of the retina; its veins pass into those of the iris and choroid. The vitreous humour at the 4th week is represented by a cellular mass between the lens and the retina (Kölliker). The pupillary membrane disappears at the 7th month. It may remain throughout life (V).

Organ of Smell.—On the under surface and lateral limit of the fore-brain, the epiblast forms a groove or pit with thickened epithelium, which forms a depression towards the brain, but always remains as a pit or depression; this is the *olfactory* or *nasal pit*, to which the olfactory nerve afterwards sends its branches.

Organ of Hearing.—On both sides of the after-brain there is a depression or pit formed in the epiblast, which gradually extends deeper towards the brain—this is the *labyrinth pit*. The pit is ultimately completely cut off from the epiblast, just like the lens, and is now called the *vesicle of the labyrinth*. It represents the utricle, from which, at the 2nd month, the semicircular canals and the cochlea are developed. The union with the brain occurs later along with the development of the auditory nerve. The first visceral cleft remains as an irregular passage from the Eustachian tube to the external auditory meatus. The *outer ear* appears at the 7th week.

453. Birth.

With the growth of the ovum, the uterus becomes more distended, its walls more muscular and more vascular. Towards the end of gestation the neck disappears as such, and after a period of 280 days of gestation “labour” begins, whereby the contents of the uterus are discharged. The labour pains occur rhythmically and periodically, being separated from each other by intervals free from pain. Each pain begins gradually, reaches a maximum, and then slowly declines. With each pain the heat of the uterus increases (§ 302), while the heart-beat of the foetus becomes slower and feebler, which is due to stimulation of the vagus in the medulla oblongata (§ 369, 3).

[**Power in Ordinary Labours.**—Sometimes the ovum is expelled whole, the membranes containing the liquor amnii remaining unruptured. Poppel has pointed out that the force which ruptures the bag of membranes is sufficient to complete delivery, so that, as Matthews Duncan remarks, the strength of the membranes gives us a means of ascertaining the power of labour in the easiest class of natural labours. Matthews Duncan, from experiments on the pressure required to rupture the membranes, concludes that the great majority of labours are completed by a propelling force not exceeding 40 lbs.]

Polaillon estimates the pressure exerted by the uterus upon the fœtus at each pain to be 154 kilos. [338·8 lbs.], so that, according to this calculation, the uterus at each pain performs 8,820 kilogrammetres of work (§ 301). [This estimate is certainly far too high.]

After-birth.—After the fœtus is expelled, the placenta remains behind; but it is soon expelled by the contractions of the uterus. During the contraction of the uterus to expel the placenta, a not inconsiderable amount of the placental blood is forced into the child (§ 40). After a time the placenta, the membranes, and the decidua—constituting the *after-birth*—are expelled.

Influence of Nerves on the Uterus.—1. Stimulation of the hypogastric plexus causes contraction of the uterus. The fibres arise from the spinal cord, from the last dorsal, and upper 3 or 4 lumbar nerves run into the sympathetic, and then reach the hypogastric plexus (Frankenhäuser). 2. Stimulation of the *nervi erigentes*, which are derived from the sacral plexus, causes movement (v. Basch and Hofmann). 3. Stimulation of the lumbar and sacral parts of the cord causes powerful movements (Spiegelberg, Schiff). There is a *centre for the act of parturition* in the lumbar region of the cord (§ 362, 6). The uterus, like the intestine, probably contains *independent* or *parenchymatous nerve-centres* (Körner), which can be excited by suspension of the respiration, and by anæmia (by compressing the aorta—Spiegelberg—or rapid hæmorrhage). Decrease of the bodily temperature diminishes the movement, while an increase of the temperature increases it, which, however, ceases during high fever (Fromme). The experiments made by Rein upon bitches show that, if all the nerves going to the uterus be divided, practically all the functions connected with conception, pregnancy, and parturition can take place, even although the uterus is separated from all its cerebro-spinal connections. Hence, we must look to the presence of some *automatic ganglia* in the uterus itself. According to Dembo, there is a centre in the anterior wall of the vagina of the rabbit. According to Jastreboff, the vagina of the rabbit contracts rhythmically. Sclerotic acid greatly excites the uterine contractions (v. Swiecicki). 5. The uterus contracts *reflexly* on stimulating the central end of the sciatic nerve (v. Basch and Hofmann), the central end of the brachial plexus (Schlesinger), and the nipple (Scanzoni). 6. The uterus is supplied by *vaso-motor nerves* (hypogastric plexus), which come from the splanchnic; and also by *vaso-dilator fibres*, the latter through the *nervi erigentes*. The vaso-motor nerves are affected reflexly by stimulation of the sciatic nerve (v. Basch and Hofmann).

Lochia.—After birth, the whole mucous membrane (decidua) is shed; its inner surface, therefore, represents a large wounded surface, on which a new mucous membrane is developed. The discharge given off after birth constitutes the lochia.

Involution of the Uterus.—After birth, the thick, muscular mass decreases in size, some of its fibres undergoing fatty degeneration. Within the lumen of the blood-vessels of the uterus itself, there begins in the intima of these vessels a proliferation of the connective-tissue elements, whereby, within a few months, the blood-vessels so affected become completely occluded. The smooth muscular fibres of the middle coat of the arteries undergo fatty degeneration. The relatively large vascular spaces in the region of the placenta are filled by blood-clots, which are ultimately traversed by outgrowths of the connective-tissue of the vascular walls.

Milk-Fever.—After birth, there is a peculiar action on the vasomotor system constituting milk-fever, while at the 2nd–3rd day, there is a more copious supply of blood to the mammary gland for the secretion of milk (§ 231). The cause of the first respiration in the child is referred to at p. 883.

454. Comparative—Historical.

A sketch of the development of man must necessarily have some reference to the general scheme of development in the Animal Kingdom. The question as to how the numerous forms of animal life at present existing on the Globe have arisen has been answered in several ways. It has been asserted that each species has retained its characters unchanged from the beginning, so that we speak of the “constancy of species.” This view, developed by Linnaeus, Cuvier, Agassiz, and others, is opposed by that supported by Lamarck (1809), or the doctrine of the “Unity of the Animal Kingdom,” corresponding to the ancient view of Empedocles, that all species of animals were derived by variations from a few fundamental forms; that at first there were only a few lower forms from which the numerous species were developed—a view supported by Geoffroy St. Hilaire, and Goethe. After a long period this view was restated and elucidated in the most brilliant and most fruitful manner by Charles Darwin (1859) in his “Origin of Species,” and other works. He attempted to show how modifications may be brought about by uniform and varying conditions acting for a long time. Amongst created beings each one struggles with its neighbour, so that there is a real “*struggle for existence.*” Many qualities, such as vigour, rapidity, colour, reproductive activity, &c., are hereditary, so that in this way by “*natural selection*” there may be a gradual improvement, and therewith a gradual change of the species. In addition, organisms can, within certain limits, accommodate themselves to their surroundings or environment. Thus, certain useful organs or parts may undergo development, while inactive or useless parts may undergo retrogression, and form “rudimentary organs.” This process of “*natural selection,*” causing gradual changes in the form of organisms, finds its counterpart in “*artificial selection*” amongst plants and animals. Breeders of animals, for example, by selecting the proper crosses, can within a relatively short time produce very material alterations in the form and characters of the animals which they breed, the changes being more pronounced than many of those that separate well-defined species. But, just as with artificial selection, there is sometimes a sudden “*reversion*” to a former type, so in the development of species by natural selection there is sometimes a condition of *atavism.* Obviously, a wide distribution of one species in

different climates must increase the liability to change, as very different conditions of environment come into play. Thus, the migration of organisms may gradually lead to a change of species.

Biological Law.—Without discussing the development of different organisms, we may refer to the “*fundamental biological law*” of Haeckel, viz., “that the ontogeny is a short repetition of the phylogeny,” [ontogeny being the history of the development of *single* beings, or of the individual from the ovum onwards, while *phylogeny* is the history of the development of a *whole stock* of organisms, from the lowest forms of the series upwards] (p. XX). When applied to man, this law asserts that the individual stages in the course of the development of the human embryo, e.g., its existence as a unicellular ovum, as a group of cells after complete cleavage, as a blastodermic vesicle, as an organism without a body-cavity, etc.; that these stages of development indicate or represent so many animal forms, through which the human species in the course of untold ages has been gradually evolved. The individual stages which the human race has passed in this process of evolution are rapidly rehearsed in its embryonic development. This conception has not passed without challenge. In any case, the comparison of the human development and its individual organs with the corresponding perfect organs of lower vertebrates, is of great importance. Thus, a mammal during the development of its organs is originally possessed of the tubular heart, the branchial clefts, the undeveloped brain, the cartilaginous chorda dorsalis, and many arrangements of the vascular system, etc., which are permanent throughout the life of the lowest vertebrates. These incomplete stages are perfected in the ascending classes of vertebrates. Still, there are many difficulties to contend with in establishing both the evolution hypothesis of Darwin and the biological law of Haeckel.

Historical.—Although the impetus to the study of the history of development has been most stimulated in recent times, the ancient philosophers held distinct but very varied views on the question of development. Passing over the views of Pythagoras (550 B.C.) and Anaxagoras (500 B.C.), Empedocles (473 B.C.) taught that the embryo was nourished through the umbilicus; while he named the chorion and amnion. Hippocrates observed incubated eggs from day to day, noticed that the allantois protruded through the umbilicus, and observed that the chick escaped from the egg on the 20th day. He taught that a 7 months’ foetus was viable, and explained the possibility of superfœtation from the horns of the uterus. The writings of Aristotle (born 384 B.C.) contain many references to development, and many of them are already referred to in the text. He taught that the embryo receives its vascular supply through the umbilical vessels, and that the placenta sucked the blood from the vascular uterus, like the rootlets of a tree absorbing moisture. He distinguished the polycotyledonary from the diffuse placenta; and he referred the former to animals without a complete row of teeth in both jaws. In the incubated egg of the chick, he distinguished the blood-vessels of the umbilical vesicle, which carried food from the cavity of the latter, and also the allantois. He also observed that the head of the chick lay on its right leg, and that the umbilical sac was ultimately absorbed into the body. The formation of double monsters, he ascribed to the union of two germs or two embryos lying near each other. During generation, the female produces the matter, the male, the principle which gives it form and motion. There are also numerous references to reproduction in the lower animals. Erasistratus (304 B.C.) described the embryo as arising by new formations with the ovum (*Epigenesis*), while his contemporary, Herophilus, found that the pregnant uterus was closed. He was aware of the glandular nature of the prostate, and named the vesiculæ seminales and the epididymis. Galen (131–203 A.D.) was acquainted with the existence of the foramen ovale, and the course of the blood in the foetus through it, and through the ductus arteriosus. He was also aware of the physiological relation between the breast and the blood-

vessels of the uterus, and he described how the uterus contracted on pressure being applied to it. In the Talmud, it is stated that an animal with its uterus extirpated may live, that the pubes separates during birth, and there is a record of a case of Cæsarian section, the child being saved. Sylvius described the value of the foramen ovale; Vesalius (1540) the ovarian follicles; Eustachius (†1570) the ductus arteriosus (Botalli) and the branches of the umbilical vein to the liver. Arantius investigated the duct which bears his name, and he asserted that the umbilical arteries do not anastomose with the maternal vessels in the placenta. In Libavius (1597) it is stated that the child may cry *in utero*. Riolan (1618) was aware of the existence of the Corpus Highmorianum testis. Pavius (1657) investigated the position of the testes in the lumbar region of the fœtus. Harvey (1633) stated the fundamental axiom, "*Omne vivum ex ovo.*" Fabricius ab Aquapendente (1600) collected the materials known for the history of the development of the chick. Regner de Graaf described more carefully the follicles which bear his name, and he found a mammalian ovum in the Fallopian tube. Swammerdam († 1685) discovered metamorphosis, and he dissected a butterfly from the chrysalis before the Grand Duke of Tuscany. He described the cleavage of the frog's egg. Malpighi († 1694) gave a good description of the development of the chick with illustrations. Hartsoecker (1730) asserted that the spermatozoa pass into the ovum. The first half of the 18th century was occupied with a discussion as to whether the ovum or the sperm was the more important for the new formation (the Ovulists and Spermatists); and also as to whether the fœtus was formed or developed within the ovum (Epigenesis), or if it merely increased in growth. The question of spontaneous generation has been frequently investigated since the time of Needham in 1745.

New Epoch.—A new epoch began with Caspar Fried. Wolff (1759), who was the first to teach that the embryo was formed from layers, and that the tissues were composed of smaller parts (corresponding to the cells of the present period). He observed exactly the formation of the intestine. William Hunter (1775) described the membranes of the pregnant uterus. Sæmmering (1799) described the formation of the external human configuration, and Oken and Kiesser that of the intestines. Oken and Goethe taught that the skull was composed of vertebrae. Tiedemann described the formation of the brain, and Meckel that of monsters. The basis for the study of the development of an animal from the layers of the embryo, was laid by the researches of Pander (1817), Carl Ernst v. Baer (1828-1834), Remak, and many other observers; and Schwann was the first to trace the development of all the tissues from the ovum. [Schleiden enunciated the cell theory with reference to the minute structure of vegetable tissues, while Schwann applied the theory to the structure of animal tissues. Amongst those whose names are most prominent in connection with the evolution of this theory are Martin Barry, von Mohl, Leydig, Remak, Goodsir, Virchow, Beale, Max Schultze, Brücke, and a host of recent observers.]

INDEX.

- Abdominal muscles** in respiration, 240.
Abdominal reflex, 850.
Abducens, 803.
Abiogenesis, 1100.
Absolute blindness, 921.
Absorption by fluids, 51.
 " by solids, 51.
Absorption of—
 Colouring matter, 398.
 Digested food, 392.
 Forces of, 399.
 Grape-sugar, 396.
 Influence of nerves on, 400.
 Nutrient enemata, 400.
 Organs of, 386.
 Oxygen, 261.
 Peptones, 396.
 Small particles, 398.
 Solutions, 395.
 Unchanged proteids, 397.
Absorption spectra, 28.
Accelerans nerve, 887.
 " in frog, 890.
Accommodation of eye, 795.
 " defective, 983.
 " force of, 984.
 " line of, 980.
 " phosphene, 996.
 " range of, 981.
 " spot, 996.
 " time for, 980.
Accord, 1064.
Acetic acid, 374, 509.
Aceton, 354, 545, 562.
Acetonæmia, 354.
Acetylene, 33.
Achromatopsy, 1016.
Achroodextrin, 294, 340.
Acid-albumin, 331, 503.
Acoustic nerve, 809.
Acrylic acid series, 508.
Action currents, 788.
Active insufficiency, 675.
Addison's disease, 783, 214.
Adelomorphous cells, 322.
Adenoid tissue, 406.
Adipocere, 488.
Adventitia, 121.
Ægophony, 246.
Ærobes, 373.
Æsthesiometer, 1088.
Æsthesodic substance, 855.
Afferent nerves, 783.
After-birth, 1162.
After-images, 1018.
After-sensation, 954.
Ageusia, 1083.
Agoraphobia, 813.
Agrammatism, 932.
Agraphia, 931.
Ague, 451.
Air, composition of, 254.
 " diffusion of, 259.
 " expired, 255.
 " quantity exchanged, 256.
Air cells, 221.
Alanin, 504.
Albuminoids, 504.
Albumins, 502.
Albuminuria, 551.
Alcohol, 329.
Alcohols, 510.
Alcoholic drinks, 473.
Alexia, 933.
Alkali-albumin, 342, 503.
Alkaline fermentation, 549.
Alkaloids, 473.
Alkophyr, 333.
Allantoin, 513, 542.
Allantois, 1134.
Allôchiria, 1096.
Alloxan, 536.
Almén's test, 557.
Alternate hemiplegia, 870.
 " paralysis, 870.
Alternation of generations, 1102.
Amaurosis, 788.
Amblyopia, 788.
American crow-bar case, 903.
Amido-acid, 513.
Amidocaproic acid, 341.
Amines, 513.
Aminia, 931.
Ammoniæmia, 584.
Amnesia acustica, 922.
Amnion, 1133.
Amniota, 1133.
Amniotic fluid, 1133.
Amœboid movement, 612.
Ampère's rule, 735.
Amphiarthroses, 672.
Amphoric breathing, 246.
Amygdalin, 418.
Amyloid substance, 503.
Amylopsin, 340.
Amylum, 512.
Anacrotism, 146.
Anæmia, 23.
 " metabolism in, 63.
 " pernicious, 23.
Anærobes, 373.
Anæsthesia dolorosa, 1069.
Anæsthetics, 992.
Anæsthetic leprosy, 783.
Anakusis, 810.
Analgesia, 858.
Analgia, 1097.
Anamnia, 1133.
Anarthria, 930.
Anelectrotous, 760.
Aneurism, 157.
Angioneuroses, 899.
Angiograph, 133.
Anidrosis, 609.
Animals, characters of, xxviii.
Animal foods, 479.
 " magnetism, 909.
Anions, 736.
Anisotropous substance, 624, 641.
Ankle clonus, 852.
Anode, 736.
Anosmia, 785.
Antagonistic muscle, 676.
Anthracometer, 250.
Anthracosis, 224, 272.
Antiar, 418.
Antipeptone, 342.
Antiperistalsis, 313.
Aperistalsis, 316.
Apex-beat, 80, 89, 91.
Aphakia, 964.
Aphasia, 930.
Aphonia, 705.
Apnoea, 878.
Appunn's apparatus, 1069.
Apselfaphesia, 1096.
Aqueous humour, 965.
Arachnoid mater, 947.
Archiblastic cells, 1128.
Area opaca, 1100.
 " pellucida, 1100.
 " vasculosa, 1100.
Argyll Robertson pupil, 991.
Arhythmia cordis, 143.

- Aromatic acids, 510.
 " oxyacids, 514, 545.
 Arrector pili muscle, 599.
 Arteries, 120.
 " development of, 1149.
 " emptiness of, 892.
 " rhythmical contraction of, 895.
 " sounds in, 192.
 " structure of, 120.
 " tension in, 139.
 " termination in veins, 187.
 Arthroal joints, 672.
 Articular cartilage, 669.
 Articulation nerve - corpuscles, 1086.
 Artificial cold - blooded condition, 456.
 Artificial digestion, 334.
 " gastric juice, 330.
 " pancreatic juice, 344.
 " respiration, 883.
 " Marshall Hall's method, 883.
 " Sylvester's method, 883.
 Asparaginic acid, 341, 513.
 Asphyxia, 268, 879.
 " recovery from, 271.
 Aspirates, 703.
 Aspiration of heart, 175.
 Assimilation, 458.
 Associated movement, 991.
 Astatic needles, 735.
 Asteatosis, 610.
 Asthma nervosum, 822.
 Astigmatism, 988.
 " correction of, 989.
 " test for, 989.
 Atavism, 1163.
 Ataxaphasia, 932.
 Ataxia, 828, 919, 928, 931.
 Ataxic tabes, 858.
 Atelectasis, 247.
 Atmospheric pressure, 275.
 " diminution of, 276.
 " increase of, 277.
 Atresia ani, 1133.
 Atrophy of the face, 803.
 Atropin in eye, 789.
 Attention, time for, 907.
 Audible tone, lowest, 1066.
 Auditory after sensations, 1076.
 " area, 922.
 " delusions, 810.
 " meatus, 1046.
 " nerve, 1043.
 Auditory ossicles, 1049.
 " perception, 1065.
 Auerbach's plexus, 316, 392.
 Automatic excitement, 835.
 Autonomy, 909.
 Auxocardie, 110.
 Axis of vision, 1005.
Bacillus, 293, 372, 565.
 " amylobacter, 379.
 " butyricus, 374.
 " subtilis, 374.
 Bacterium, 272, 293, 372, 380, 468, 565, 609.
 " aceti, 374.
 " cyanogeneum, 468.
 " foetidum, 610.
 " lacticum, 373.
 " synxanthum, 468.
 " termo, 379.
 Ball and socket joints, 671.
 Bantingism, 489.
 Baraesthesiometer, 1029.
 Basal ganglia, 935.
 Basedow's disease, 899.
 Bases, 500.
 Basilar membrane, 1062.
 Beats, 1064.
 " successive, 1064.
 " isolated, 1064.
 Bed-sore, 783.
 Beef-tea, 471.
 Beer, 475.
 Bell's law, 825.
 " deductions from, 827.
 Bell's paralysis, 808.
 Benzoic acid, 356.
 Bert's experiment, 771.
 Bile, acids, 355.
 " composition of, 355, 359.
 " ducts, 348.
 " " ligature of, 349.
 " effect of drugs on, 364.
 " excretion of, 361.
 " fate of, 367.
 " functions of, 365.
 " pigments, 357, 508.
 " reabsorption of, 362.
 " secretion of, 359.
 " test for, 356, 357, 558.
 Biliary fistula, 361.
 Bilicyanin, 358.
 Bilifuscin, 358.
 Biliprasin, 358, 559.
 Bilirubin, 357.
 Biliverdin, 357.
 Binocular vision, 1028.
 Biological law, 1164.
 Biology, xix.
 Birth, 1161.
 Biuret reaction, 333.
 Blastoderm, 1123.
 Blastosphere, 1122.
 Blepharospasm, 809.
 Blind spot, 1002.
 Blood, 1.
 " analysis, 37.
 " arterial, 60.
 " carbonic acid in, 55, 58.
 " coagulation, 40.
 " colour, 2.
 " colouring matter, 23.
 " defibrinated, 40.
 " electrical condition of, 778.
 " extractives, 50.
 " fats in, 50, 64.
 " lake-coloured, 10.
 " nitrogen in, 55, 59.
 " odour, 2.
 " oxygen in, 55, 56.
 " ozone in, 57.
 " plasma, 37.
 " plates, 21.
 " quantity, 60, 185.
 " reaction, 2.
 " salts in, 51, 64.
 " serum, 37.
 " specific gravity, 2.
 " taste, 2.
 " transfusion of, 61.
 " water in, 51.
 Blood-channels, intercellular, 125.
 Blood-corpuscles—stroma, 36.
 " abnormal changes, 23.
 " abnormal conditions, 22.
 " action of reagents on, 19.
 " amoeboid movements, 18, 20.
 " circulation of, 188.
 " change of form, 8.
 " chemical composition, 36, 37.
 " colour, 8.
 " crenation, 7.
 " decay, 16.
 " diapedesis, 21.
 " distribution of, 196.
 " effect of reagents, 7.
 " form, 3, 18.
 " Gower's method, 6.
 " human, red, 3.
 " " white, 17.
 " intracellular origin, 14.

- Blood-corpuseles—
 Malassez's method, 5.
 ,, number, 4, 19.
 ,, of newt, 18.
 ,, origin, 12, 13, 15.
 ,, pathological changes,
 17.
 ,, size, 3, 18.
 ,, stroma, 7.
 ,, transfusion of, 199.
 ,, weight, 4.
 Blood-current, 159.
 ,, in capillaries, 161.
 ,, velocity of, 179, 182.
 Blood-gases, 51.
 ,, estimation of O, CO₂,
 and N, 55.
 ,, extraction, 53.
 ,, gas pumps for, 53.
 ,, quantity, 55.
 Blood-islands, 12.
 Blood-pressure, 162.
 ,, arterial, 166.
 ,, capillary, 172.
 ,, estimation of, 162.
 ,, in pulmonary artery,
 177.
 ,, in veins, 175.
 ,, variations of, 166.
 Blood-vessels, 119.
 ,, action of acids on,
 125.
 ,, cohesion of, 127.
 ,, elasticity of, 126.
 ,, pathology of, 127.
 ,, properties of, 119.
 ,, structure of, 120.
 Blue pus, 609.
 ,, sweat, 609.
 Body, vibrations of, 157.
 Body-wall, formation of,
 1131.
 Bone, chemical composition
 of, 1147.
 ,, callus of, 496.
 ,, development of, 1147.
 ,, effect of madder on,
 496.
 ,, fracture of, 496.
 ,, growth of, 1147.
 ,, histogenesis of, 1146.
 Bothrioccephalus, 1102.
 Büttger's test, 297.
 Boutons terminals, 1087.
 Bowman's tubes, 956.
 Box pulse-measurer, 128.
 Bradyphasia, 932.
 Brain, 861.
 ,, arteries of, 866.
 ,, blood-vessels of, 862.
 ,, general scheme of,
 861.
 ,, impulses, course of,
 868.
 ,, influence of, on cord,
 898.
 Brain in invertebrata, 951.
 ,, membranes of, 946.
 ,, motor centres of, 913.
 ,, movements of, 947.
 ,, pressure on, 950.
 ,, protective apparatus
 of, 946.
 ,, psychical functions
 of, 903.
 ,, pyramidal tracts of,
 868.
 ,, topography of, 935.
 ,, weight of, 861.
 Brandy, 475.
 Bread, 471.
 Brenner's formula, 810.
 Broca's convolution, 930.
 Bromidrosis, 609.
 Bronchial fremitus, 246.
 ,, breathing, 245.
 Bronchiole, 220.
 Bronchophony, 246.
 Bronchus extra pulmon-
 ary, 219.
 ,, intra pulmonary,
 220.
 ,, small, 220.
 Bronzed skin, 214.
 Brownian movement, 293.
 Bruit, 192.
 ,, *de diable*, 193.
 Brunner's glands, 368, 390.
 Bulbar paralysis, 678, 876.
 Butter, 465.
 Butyric acid, 374, 509.
 Caffein, 473.
 Calabar bean on eye, 789.
 Calcic phosphate, 499.
 Callus, 496.
 Caloric, 423.
 Calorimeter, 422.
 Canal of cochlea, 1060.
 ,, hyaloid, 964.
 ,, Nuck, 1156.
 ,, Petit, 963.
 ,, Schlemm, 958.
 ,, semicircular, 1060.
 ,, of spinal cord, 836.
 ,, of Stilling, 964.
 Canalis cochlearis, 1060.
 ,, reuniens 1060.
 Capillaries, 122.
 ,, action of silver
 nitrate on, 122.
 ,, development of,
 13.
 ,, form and ar-
 rangement of,
 186.
 ,, stigmata of, 122.
 ,, velocity of blood
 in, 182.
 Capillary electrometer,
 749.
 Capsule, external, 938.
 Capsule, Glisson, 346.
 ,, internal, 938.
 ,, of Tenon, 965.
 Carbolic acid urine, 544.
 Carbohydrates, 335, 511.
 ,, fermentation
 of, 373.
 Carbonic acid, xxix.
 ,, conditions
 affecting, 256.
 ,, estimation of,
 250.
 ,, excretion of, 261.
 ,, in air, 254.
 ,, in blood, 58.
 ,, in expired air,
 254.
 Carbonic oxide, 32.
 ,, hæmoglobin, 31.
 ,, poisoning by,
 31.
 Cardiac ganglia, 98.
 ,, hypertrophy, 79.
 ,, impulse, 80.
 ,, murmurs, 95.
 ,, nerves, 97.
 ,, plexus, 887.
 ,, poisons, 887.
 ,, revolution, 76.
 ,, sounds, 88.
 Cardinal points, 972.
 Cardiogram, 80.
 Cardiograph, 81.
 Cardio-inhibitory centre,
 884.
 ,, nerves, 818.
 Cardio-pneumatic move-
 ment, 109.
 Caricin, 342.
 Carnin, 514, 626.
 Carotid gland, 124, 215.
 Casein, 464, 503.
 Cataphoric action, 742.
 Cataract, 963.
 Cathelotrotonus, 760.
 Cathode, 736.
 Caudal heart of eel, 418.
 Cavernous formations, 124.
 Cells, division of, 1100.
 Cellulose, 294, 512.
 Cement substance, 301,
 405.
 ,, action of silver
 nitrate on, 405.
 Centre, accelerans, 887.
 ,, cardio-inhibitory,
 884.
 ,, ciliospinal, 853.
 ,, closure of eyelids,
 874.
 ,, ejaculation, 853.
 ,, erection, 853, 1117.
 ,, for coughing, 875.
 ,, for defæcation, 853.
 ,, heat regulating,
 901.

- Centre for mastication, 875.
 ,, micturition, 853.
 ,, parturition, 854.
 ,, pupil, 853, 875, 989.
 ,, respiratory, 876.
 ,, for saliva, 875.
 ,, sneezing, 874.
 ,, spasm, 901.
 ,, speech, 929.
 ,, swallowing, 875.
 ,, sweat, 854, 902.
 ,, vaso-dilator, 900.
 ,, vaso-motor, 854, 890.
 ,, vomiting, 875.
 Centre of gravity, 679.
 Centrifugal nerves, 781.
 Centripetal nerves, 783.
 Centro-acinar cells, 338.
 Cereals, 471.
 Cerebellum—
 Action of electricity on, 946.
 Connections of, 866.
 Function of, 944.
 Pathology of, 946.
 Removal of, 944.
 Structure of, 943.
 Cerebral arteries, 866.
 ,, epilepsy, 917, 929.
 ,, fissures, dog, 916.
 ,, inspiratory centre, 877.
 ,, motor centres, 910, 913.
 ,, sensory centres, 920.
 ,, vesicles, 1125.
 Cerebrin, 508, 718.
 Cerebro-spinal fluid, 947.
 Cerebrum, 861.
 ,, blood-vessels of, 862, 948.
 ,, convolutions of, 910.
 ,, epilepsy of, 917.
 ,, excision of centres, 918.
 ,, extirpation of, 904.
 ,, Flourens' doctrine, 903.
 ,, functions of, 903.
 ,, Goltz's theory of, 924.
 ,, imperfect development of, 903.
 ,, lobes of, 910.
 ,, motor centres of, 910, 913.
 ,, motor regions of, 925.
 ,, movements of, 947.
 ,, sensory centres, 920.
 ,, sensory regions of, 932.
 ,, structure of, 861.
 ,, sulci and gyri of, 907.
 ,, tactile areas of, 934.
 Cerebrum, thermal centres
 of, 924.
 ,, weight of, 907.
 Cerumen, 604.
 Cervical sympathetic, section of, 833.
 Chalazæ, 1100.
 Charcot's crystals, 275.
 Cheese, 468.
 Chemical affinity, xxvi.
 Chess-board phenomenon, 1036.
 Chest, dimensions of, 239.
 Cheyne-Stokes' phenomenon, 233.
 Chiasma, 785, 786.
 Chitin, 508.
 Chlorophane, 963.
 Chlorosis, 23.
 Chocolate, 473.
 Cholalic acid, 356, 510.
 Cholesteræmia, 365.
 Cholesterin, 358, 367, 510.
 Cholestin, 358, 559.
 Cholin, 718.
 Choloidinic acid, 356.
 Choluria, 558.
 Chondrin, 505.
 ,, peptone, 335.
 Chondrogen, 505.
 Chorda dorsalis, 1127.
 Chorda tympani, 805.
 Chordæ tendinæ, 78.
 Chorion læve, 1137.
 ,, frondosum, 1137.
 ,, primitive, 1123.
 Choroid, 958.
 Choroidal fissure, 1160.
 Christison's formula, 526.
 Chromatic aberration, 987.
 Chromatophores, 611.
 Chromatopsia, 788.
 Chromidrosis, 609.
 Chromophanes, 963.
 Chronograph, 645.
 Chyle, 410, 412.
 ,, movement of, 415.
 ,, vessels, 401.
 Chylous urine, 567.
 Chyme, 331.
 Cicatricula, 1110.
 Cilia, 612.
 ,, conditions for movement, 613.
 ,, effect of reagents on, 613.
 ,, functions of, 614.
 Ciliary motion, 612.
 ,, force of, 614.
 ,, ganglion, 793.
 ,, muscle, 958.
 ,, nerves, 793.
 Ciliated epithelium, 613.
 Cilio-spinal region, 990.
 Circle of Willis, 948.
 Circulating albumin, 477.
 Circulation, capillary, 187.
 ,, first, 1130.
 ,, portal, 65.
 ,, pulmonary, 65.
 ,, schemata of, 161.
 ,, second, 1130.
 ,, systemic, 65.
 Circumpolarisation, 561.
 Cleavage of yolk, 1123.
 ,, lines of, 1123.
 ,, partial, 1127.
 Cleft sternum, 1142.
 Clerk-Maxwell's experiment, 997.
 Clitoris, 1157.
 Closing, continued contraction, 765.
 Closing shock, 743.
 Clothing, 444.
 Coagulable fluids, 49.
 Coagulated proteids, 503.
 Coagulation experiments, 46.
 Cocaine, 991.
 Coccygeal gland, 215.
 Coclea, 1059.
 Coecitas verbalis, 933.
 Coelom, 1128.
 Coffee, 473.
 Cold-blooded animals, 426.
 Cold on the body, 455.
 ,, uses of, 456.
 Collagen, 335, 505.
 Colloids, 394.
 Coloboma, 1160.
 Colostrum, 462.
 Colour associations, 1076.
 Colour sensation, 1013, 1010.
 ,, Young - Helmholtz theory, 1013.
 ,, Hering's theory, 1014.
 Colour-blindness, 1015, 1016.
 ,, acquired, 1017.
 ,, testing, 1819.
 Colour top, 1019.
 Colours, complementary, 1016.
 ,, contrast, 1011.
 ,, geometrical table, 1012.
 ,, methods of mixing, 1011.
 ,, mixed, 1010.
 ,, simple, 1010.
 Columella, 1077.
 Columns of the cord, 840.
 Comedo, 610.
 Common sensation, 1096.
 Comparative—
 Absorption, 420.
 Circulation, 215.
 Digestion, 383.

- Comparative —
 Hearing, 1076.
 Heat, 457.
 Kidney and urine, 592.
 Metabolism, 514.
 Motor organs, 683.
 Nerve centres, 950.
 Nerves and electro-physiology, 779.
 Peripheral nerves, 834.
 Reproduction and development, 1163.
 Respiration, 277.
 Sight, 1040.
 Skin, 611.
 Voice and speech, 706.
 Compensation, 749.
 Complementary air, 227.
 Complementary colours, 1011.
 Compound eye, 1041.
 Condensed milk, 468.
 Condiments, 473, 475.
 Conduction in the cord, 856.
 Conductivity, 770.
 Conglutin, 504.
 Conjugation, 1101.
 Connective-tissue spaces, 402.
 Consonance, 1063.
 Consonants, 703.
 Constant current, use of, 773.
 Constant elements —
 Bunsen's, 738.
 Daniell's, 738.
 Grennet, 739.
 Grove's, 737.
 Leclanché, 739.
 Smee's, 738.
 Constipation, 382.
 Contraction, muscular (see *Myogram*).
 „ of blood-corpuscles, 18.
 „ of blood-vessels, 125.
 „ remainder, 651.
 „ without metals, 751.
 Contracture, 651.
 Contrast, 1021.
 „ colours, 1011.
 Convergent lens, action of, 967.
 Cornea, 955.
 Coronary vessels, 73.
 „ effects of ligation of, 75.
 Corpora quadrigemina, 939.
 Corpulence, 488.
 Corpus callosum, 942.
 „ luteum, 1115.
 „ striatum, 935.
 Cortical blindness, 921.
 Corti's organ, 1060.
 Cotyledons, 1139.
 Coughing, 248.
 „ centre for, 875.
 Cranial flexures, 1125.
 „ nerves, 784.
 Crescents of Gianuzzi, 282.
 Crista acustica, 1061.
 Crossed reflexes, 844.
 Crusta petrosa, 301.
 „ phlogistica, 39.
 Crying, 249.
 Crystallin, 502, 963.
 Crystalline spheres, 1041.
 Crystallised bile, 355.
 Crystalloids, 394.
 Curara, action of, 418, 634, 638.
 Cutaneous respiration, 264.
 „ trophic affections, 782.
 Cuticular membrane, 300.
 Cyanogen, 33.
 Cyanuric acid, 513.
 Cylindrical lenses, 987.
 Cyrtometer, 242.
 Cysticercus, 1102.
 Cystin, 513, 562.
 Daltonism, 1016.
 Darby's fluid meat, 333.
 Damping apparatus, 1049.
 Death of a nerve, 731.
 Debove's membrane, 219, 388.
 Decidua vera, 1135.
 „ reflexa, 1136.
 „ serotina, 1136.
 Decubitus acutus, 942.
 Defæcation, 314.
 „ centre for, 853.
 Deglutition, 305.
 „ nerves of, 307.
 Demarcation current, 758.
 Demodex folliculorum, 604.
 Dentine, 300.
 Dentition, 303.
 Depressor nerve, 817.
 „ fibres, 894.
 Development, chronology of, 1140.
 Dextrin, 512, 562.
 Dextrose, 511.
 Diabetes mellitus, 352, 559, 890.
 Diabetic coma, 354.
 Dialysis, 394.
 Diapedesis, 189.
 Diaphragm, 235.
 Diarrhœa, 382.
 Diastatic action, 293, 359, 506.
 Dirotic pulse, 140.
 „ wave, 137.
 Diet, effect of age on, 482.
 „ effect of work on, 481.
 Diet of carbohydrates, 485.
 „ flesh, 485.
 „ flesh and fat, 485.
 „ quality of, 478.
 „ quantity, 480.
 Difference theory, 758.
 Differential rheotom, 755.
 „ tones, 1064.
 Diffusion, 392.
 „ circles, 975.
 „ of gases, 52.
 Digestion during fever, 381.
 „ in plants, 381.
 Digestive apparatus, 298.
 Dilatation of pupil, centre for, 853.
 Dilator pupillæ, 959.
 Dioptric, 987.
 „ observations, 966.
 Diphthongia, 705.
 Diphthongs, 702.
 Diplopia, 789.
 Direct vision, 1005.
 Dissociation, 263.
 Dissonance, 1064.
 Discharging forces, 633.
 Disdiaclasses, 625.
 Distance, estimation of, 1037.
 „ false estimate of, 1033.
 Diuretics, 572.
 Double conduction in nerve, 771.
 Double images, neglect of, 1031.
 Dreams, 908.
 Dromograph, 181.
 Dropsy, 419.
 Ductus arteriosus, 1139.
 „ venosus, 1138.
 Dura mater, 946.
 Dust particles, 272.
 Dyschromatopsy, 1016.
 Dyslysin, 356.
 Dysperistalsis, 318.
 Dyspnœa, 233, 268, 879.
 Dystropodextrin, 295.
 Ear, 1043.
 „ conduction in, 1044, 1057.
 „ development of, 1161.
 „ external, 1046.
 „ fatigue of, 1076.
 „ fineness of, 1066. }
 „ labyrinth of, 1059. }
 „ meatus of, 1046.
 „ ossicles of, 1049.
 „ speculum, 1048.
 „ tympanum of, 1046.

- Earthy phosphates, 547.
 Eccentric hypertrophy, 79.
 Echinomoses, 899.
 Echo speech, 909.
 Ectoderm, 1123.
 Efferent nerves, 781.
 Egg albumin, 502, 554.
 Eggs, 468.
 Ejaculation, centre for, 853.
 Elastic after effect, 662.
 " elevations, 139.
 Elasticity of blood-vessels, 126.
 " lens, 978.
 " muscle, 661.
 Elastin, 505.
 Electrical charge of body, 778.
 " fishes, 779.
 " nerves, 771.
 " organs, 779.
 Electricity, therapeutical uses, 772.
 Electrodes, non-polarisable, 737, 739.
 " other forms, 636, 772.
 Electrolysis, 736, 751.
 Electro-motive force, 732, 750.
 Electro-physiology, 732.
 Electrotonus, 755, 760.
 " in inhibitory nerves, 762.
 " in motor nerves, 761.
 " in muscle, 762.
 " in sensory nerves, 762.
 Eleidin, 595.
 Elementary granules of blood, 22.
 Emetics, 312.
 Emmetropic eye, 977.
 Emotions, expression of, 706.
 Emulsification, 343, 365.
 Emydin, 503.
 Enamel, 301.
 Enamel-organ, 302.
 End-arteries, 187.
 " bulbs, 1038.
 " capsules, 1086.
 " organ, 781.
 Endocardial pressure, 87.
 Endocardium, 71.
 Endoderm, 1123.
 Endolymph, 1057.
 Endoneurium, 715.
 Endosmosis, 392.
 Endosmotic equivalent, 393.
 Enemata, 400.
 Energy, conservation of, xxvii.
 " potential, xxiii.
- Eneuresis nocturna, 592.
 Entoptical phenomena, 994.
 " pulse, 995.
 " perceptions, 1076.
 Enzym, 294, 506.
 Epiblast, 1123.
 Epidural space, 947.
 Epigenesis, 1164.
 Epiglottis, 307.
 Epilepsy, 902.
 Epineurium, 715.
 Eponychium, 598.
 Equator, 756.
 Erection, centre for, 853.
 " of penis, 1116.
 Erect vision, 975.
 Erythrochlorophy, 1016.
 Erythrodextrin, 294.
 Ether, xx.
 Eudiometer, 54, 250.
 Eukalyn, 513.
 Euperistalsis, 318.
 Eupnoea, 878.
 Eustachian tube, 1055.
 " catheter, 1057.
 Excitability, action of poisons on, 849.
 Excitable points of a nerve, 731.
 Excito-motor nerves, 783.
 Excretin, 376.
 Exophthalmos, 833, 899.
 Expiration, 239.
 Expiratory muscles, 235.
 Explosives, 703.
 Extensor tetanus, 844.
 External genitals, 1157.
 Extra current, 742.
 Extrapolar region, 760.
 Extremities, development of, 1133.
 Eye, 955.
 " accommodation of, 975, 983.
 " artificial, 1001.
 " astigmatism, 988.
 " chromatic aberration of, 987.
 " compound, 1041.
 " development of, 1160.
 " effect of electrical currents, 996.
 " emmetropic, 977, 982.
 " entoptical phenomena, 994.
 " excised, 993.
 " fundus of, 999.
 " hypermetropic, 983, 986.
 " illumination of, 997.
 " movements of, 1022.
 " muscles of, 1026.
 " myopic, 982, 986.
 " presbyopic, 983.
 " protective organs of, 1038.
- Eye, structure of, 955.
 Eyeballs, axis of, 1023.
 " movements of, 1022.
 " muscles of, 1025.
 " planes of, 1023.
 " positions of, 1024.
 " protrusion of, 1022.
 " retraction of, 1022.
 " simultaneous movements of, 1028.
 Eye-currents, 755.
 Eyelids, 1038.
- Facial nerve**, 285, 804.
 Faecal matter, 313, 378.
 Fallopiian tubes, 1112.
 Falsetto voice, 698.
 Faradic current, 743.
 Faradisation in paralysis, 774.
 Far point, 981.
 Fascia, lymphatics of, 416.
 Fatigue of muscle, 667.
 Fatigue stuffs, 667.
 Fats, 335, 343, 508.
 " decomposition of, 343.
 " fermentation of, 374.
 " origin of, 487.
 Fat-splitting ferment, 343.
 Fatty acids, 343, 508.
 " degeneration, 489, 729.
 Fechner's law, 953.
 Feeble digestion, 381.
 Fehling's solution, 295, 297, 560.
 Ferments, 506.
 " fate of, 371.
 " organised, 507.
 " unorganised, 506.
 Fermentation, 474, 548.
 " in intestine, 371.
 Fertilisation of ovum, 1120.
 Fever, 450.
 " after transfusion, 202.
 Fibres of Tomes, 300.
 Fibrillar contraction, 640.
 Fibrin, 22, 37, 39, 40, 64.
 Fibrin-factors, 37.
 Fibrin-ferment, 43.
 Fibrinogen, 45.
 Fibrinoplastin, 44.
 Fibrin, 505.
 Field of vision, 975.
 " contest of, 1035.
 Filaria sanguinis, 567.
 Filtration, 394.
 First respiration, discharge of, 882.

- Fission, 1100.
 Fistula, biliary, 361.
 " gastric, 330.
 " intestinal, 369.
 " pancreatic, 339.
 " Thiry's, 369.
 Flame spectra, 28.
 Fleischl's law of contraction, 766.
 Flesh, 469.
 Flight, 685.
 Flourens' doctrine, 903.
 Fluid vein, 192.
 Fluorescence, 1010.
 " of eye, 975.
 Fluorescin, 966.
 Focal line, 980.
 " point, 968, 972.
 Fœtal circulation, 1138.
 " membranes, 1139.
 Fontana's markings, 720.
 Fontanelle, pulse in, 157.
 Foramen ovale, 1139.
 Force of accommodation, 984.
 Forced movements, 940.
 Forces, xxii.
 Formative cells, 1125.
 Fovea carlica, 1130.
 " centralis, 961, 1005.
 Free acid, formation of, 328, 500.
 Friction sounds, 95, 246.
 Frog current, 751.
 Fromann's lines, 712.
 Fruits, 471.
 Fundamental note, 1048, 1067.
 Fundus glands, 321.
 Fungi, 372.
 Fusel oil, 474.
Gaertner, ducts of, 1156.
 Galactorrhœa, 464.
 Galactose, 511.
 Gallstones, 382.
 Galton's whistle, 1065.
 Galvanic battery, 732.
 " excitability, 776.
 Galvano-cautery, 778.
 Galvanometer, 735.
 " reflecting, 740.
 Galvano-puncture, 778.
 " tetanus, 724.
 Ganglionic arteries, 863, 949.
 Gangrene, 783.
 Gargling, 249.
 Gaseous exchanges, 256, 260.
 " effects on, 256, 249.
 Gases, 499.
 " indifferent, 271.
 " irrespirable, 372.
 " poisonous, 271.
 Gases, respired, 227.
 " in stomach, 336.
 Gas-pump for blood, 53.
 Gas-sphygmoscope, 135.
 Gasserian ganglion, 792.
 Gastric digestion, 331.
 " conditions affecting, 333.
 " pathological variations, 381.
 Gastric giddiness, 812.
 Gastric juice, 325, 328.
 " actions of, 331.
 " action on tissues, 335.
 " artificial, 330.
 Gelatin, 505.
 Gelatin v. albumin, 485.
 Gemmation, 1101.
 Genital eminence, 1157.
 Genu vulgum, 677.
 " varum, 677.
 Geometrical colour-table, 1012.
 Germ-epithelium, 1106, 1155.
 Germinal area, 1123.
 Gestation, period of, 1141.
 Giddiness, 811.
 Ginglymus, 670.
 Giralde's organ of, 1156.
 Glance, 1035.
 Glands, albuminous, 279.
 " Bowman's, 1078.
 " buccal, 279.
 " Brunner's, 368.
 " carotid, 124, 215.
 " ceruminous, 604.
 " changes in, 283, 284, 326.
 " coccygeal, 215.
 " Ebner's, 279.
 " fundus, 321.
 " Harderian, 1041.
 " lachrymal, 1038.
 " Lieberkuhn's, 369, 392.
 " lingual, 279.
 " lymph, 406.
 " mammary, 461.
 " Meibomian, 1038.
 " mixed, 279.
 " mucous, 279, 282.
 " Nuhn's, 279.
 " parotid, 284, 289.
 " peptic, 322.
 " Peyer's, 391.
 " pyloric, 322.
 " salivary, 280.
 " sebaceous, 601.
 " serous, 279, 283.
 " solitary, 390.
 " uterine, 1111.
 " Weber's, 279.
 Glaucoma, 797.
 Globin, 502.
 Globulins, 502.
 Glomerulus, 522.
 Glosso-pharyngeal nerve, 285, 813.
 Glossoplegia, 824.
 Glottis, 307, 690.
 Glucose, 511.
 " tests for, 297, 560
 Glucosides, 508.
 Glutaminic acid, 342, 513.
 Gluten, 504.
 Glycerin, 343, 509, 510.
 " method, 331.
 Glycerinic acid, 375.
 Glycin, 341, 356, 375, 513.
 Glycocholic acid, 355.
 Glycogen, 350, 353, 354, 512.
 Glycolic acids, 509.
 Glycosuria, 352, 559.
 Gmelin-Heintz, reaction, 357, 558.
 Goblet cells, 387.
 Goll's column, 840, 842, 857.
 Goltz's croaking experiment, 846.
 Goltz's embrace experiment, 846.
 Gorham's pupil photometer, 993.
 Gout, 585.
 Graafian follicle, 1106.
 Granulose, 294.
 Grape-sugar, 511.
 " absorption of, 396.
 " estimation of, 298.
 " in urine, 539.
 " tests for, 297, 560.
 " volumetric analysis, 560.
 Gravitation, xxii.
 Great auricular nerve, 894.
 Green-blindness, 1016.
 Green vegetables, 471.
 Growth, 497.
 " of bones, 782.
 Guanin, 539.
 Gubernaculum testis, 1156.
 Gum, 512.
 Gustatory fibres, 805.
 " region, 1080.
 " sensations, 1081.
 Gymnastics, 676.
 Gymnotus, 779.
 Gyri, 907, 911.
Hæmatin, 33, 508.
 Hæmatoblasts, 22.
 Hæmatohidrosis, 609.
 Hæmatoidin, 35, 508, 559, 1116.
 Hæmatoma aurium, 783.
 Hæmatoporphyrin, 33.
 Hæmaturia, 555.
 Hæmautography, 135.
 Hæmin and its tests, 34.

- Hæmochromogen, 83.
 Hæmocyanin, 12.
 Hæmocytolysis, 555.
 Hæmodromometer, 179.
 Hæmodynamometer, 162.
 Hæmoglobin, 23, 507.
 " analysis, 37.
 " carbonic oxide, 31.
 " compounds of, 29.
 " crystals, 24.
 " decomposition of, 33.
 " estimation of, 25.
 " nitric oxide, 32.
 " pathological, 27.
 " preparation, 24, 25.
 " proteids of, 36.
 " reduced, 30.
 " spectrum, 29.
 Hæmoglobinometer, 26.
 Hæmoglobinuria, 555.
 Hæmophilia, 41.
 Hæmorrhage, death by, 63.
 " effect of, 592.
 Hæmorrhoids, 676.
 Hæmatometer, 151.
 Hæddinger's brushes, 997.
 Hair, 593, 599.
 " follicle, 599.
 Halisteris, 677.
 Hallucinations, 909.
 Hammarsten on blood, 44, 46.
 Harderian gland, 1041.
 Hare-lip, 1143.
 Harmony, 1064.
 Harrison's groove, 233.
 Hassall's corpuscles, 212.
 Hawking, 249.
 Head-fold, 1129.
 Heart, 63.
 " accelerated action, 57.
 " action of gases, 93.
 " apex beat, 80.
 " arrangement of fibres, 67.
 " auricular systole, 76.
 " automatic centres, 95.
 " blood-vessels of, 73.
 " chordæ tendinæ, 73.
 " development of, 1123.
 " diastole, 76.
 " duration of movements, 96.
 " endocardium, 71.
 " ganglia of, 95.
 " muscular fibres, 66.
 " nerves, 97.
 " nutritive fluids, 99.
 " pericardium, 71.
 " Purkinje's fibres, 73.
 " sounds of, 91, 92, 95.
 Heart, systole, 76.
 " valves of, 72, 78.
 " weight, 73.
 " work of, 185.
 Heat, xxv.
 " balance of, 445.
 " calorimeter, 422, 434.
 " conductivity, 436.
 " employment of, 453.
 " excretion of, 442.
 " income and expenditure, 445.
 " in inflamed parts, 457.
 " latent, 422.
 " regulating centre, 891.
 " relation to work, 447.
 " sources of, 422, 424.
 " specific, 434.
 " stiffening, 631.
 " storage of, 459.
 " units, xxv., 423.
 " variations in production, 447.
 Helicotrema, 1060.
 Heller's test, 297, 552.
 " blood-test, 557.
 Helmholtz's modification, 743.
 Hemeralopia, 788.
 Hemialbuminose, 331.
 Hemianæsthesia, 771, 933, 939.
 Hemianopsia, 786.
 Hemierania, 899.
 Hemioptia, 786, 933.
 Hemipeptone, 342.
 Hemiplegia, 865.
 Hemisystole, 91.
 Henle's loop, 518.
 " sheath, 715.
 Hen's egg, 1110.
 Hensen's experiments, 1073.
 Hepatic cells, 343.
 " chemical composition of, 350.
 Hepatogenic icterus, 363.
 Herbst's corpuscles, 1056.
 Hermann's theory of tissue currents, 755.
 Herpes, 863.
 Heterologous stimuli, 952.
 Hiccough, 249.
 Hippuric acid, 540, 577.
 Hippus, 790.
 Historical—
 " Absorption, 421.
 " Circulation, 215.
 " Digestion, 354.
 " Hearing, 1076.
 " Heat, 457.
 " Kidney and urine, 592.
 " Nerves and electrophysiology, 779.
 Historical—
 " Nerve centres, 950.
 " Peripheral nerves, 834.
 " Reproduction and development, 1163.
 " Respiration, 277.
 " Sight, 1040.
 " Skin, 611.
 " Voice and speech, 706.
 Hoarseness, 706.
 Holoblastic ova, 1109.
 Homoiothermal animals, 426.
 Homologous stimuli, 952.
 Horopter, 1030.
 Howship's lacunæ, 1147.
 Humour, aqueous, 965.
 Hunger and starvation, 452.
 Hyaloid canal, 964.
 Hibernation, 257, 456.
 Hybrids, 1121.
 Hydatids, 1102.
 Hydræmia, 63.
 Hydræmion, 1134.
 Hydrobilirubin, 358, 367.
 Hydrochinon, 544.
 Hydrochloric acid, 325, 328.
 Hydrocyanic acid, 33, 271, 419.
 Hydrogen given off, 477.
 Hydrolytic ferments, 294, 506.
 Hydroxylbenzol, 544.
 Hypakusis, 810.
 Hypalgia, 1097.
 Hyperæsthesia, 856.
 Hyperakusis, 808.
 Hyperalgia, 1097.
 Hyperglobulie, 62.
 Hyperidrosis, 609.
 Hyperkinesia, 856.
 Hypermetropia, 983, 986.
 Hyperoptic, 983.
 Hyperosmia, 785.
 Hyperpselaphesia, 1095.
 Hypertrophy of heart, 79.
 Hypnotism, 909, 910.
 Hypoblast, 1123, 1129.
 Hypoglossal nerve, 824.
 Hypogeusia, 1053.
 Hypoglobulie, 62.
 Hypophysis cerebri, 214.
 Hypopselaphesia, 1096.
 Hyposmia, 785.
 Hypospadias, 1157.
 Hypoxanthin, 341, 514, 539.
 Ichthidin, 503.
 Icterus, 352.
 Identical points, 1029.
 Ileo-colic valve, 312.
 Ileus, 313.
 Illumination of eye, 997.

- Illusion, 954.
 Images, formation of, 968.
 Imbibition currents, 759.
 Impulses in brain, course of, 868.
 Inanition, 483.
 Income, 478.
 Indican, 376, 543.
 Indifferent point, 760.
 Indigo blue, 543.
 Indigogen, 543.
 Indirect vision, 1005.
 Indol, 341, 375, 414.
 Induction, 742.
 Inductorium, 745.
 Inferior maxillary nerve, 799.
 Inhibition of reflexes, 847.
 Inhibition, nature of, 848.
 Inhibitory action of brain, 925.
 Inhibitory nerves, 783.
 " for heart, 834.
 " for intestine, 319.
 " for respiration, 780.
 Inosinic acid, 514.
 Inosit, 513, 562.
 Inspiration, 232, 247.
 " forced, 234.
 " muscles of, 234.
 " ordinary, 234.
 Intelligence, degree of, 906.
 Intercentral nerves, 784.
 Intercostal muscles, 238.
 Interference, 1063.
 Interglobular spaces, 301.
 Interlobular vein, 346.
 Internal capsule, 938.
 " respiration, 265.
 " reproductive organs, 1155.
 Intestinal fistula, 369.
 " gases, 371.
 " juice, 368.
 " actions of, 370.
 " paresis, 318.
 Intestine, 312.
 " development of, 1152.
 " large, 392.
 " movements of, 312.
 " small, 386.
 Intralobular vein, 346.
 Intraocular pressure, 965, 991, 992.
 Insectivorous plants, 384.
 Intussusception, 313.
 Inulin, 512.
 Invertin, 370.
 Invert sugar, 296.
 Ions, 736.
 Iris, 959, 989.
 Iris, action of poisons on, 991.
 " blood-vessels of, 990.
 " functions of, 989.
 " movements of, 990.
 " muscles of, 989.
 " nerves of, 990.
 Irradiation, 1019.
 " of pain, 1097.
 Ischuria, 592.
 Island of Reil, 912.
 Isolated beats, 1064.
 Isotropic, 624.
Jacksonian epilepsy, 917.
 Jaeger's types, 934.
 Jaundice, 363, 558.
 Joints—
 Arthrodiol, 672.
 Joints—
 Ball and socket, 671.
 Ginglymus, 670.
 Mechanism of, 669.
 Rigid, 672.
 Screw-hinge, 670.
 Juice-canals, 402.
Karyokinesis, 1100.
 Katalepsy, 909.
 Keratin, 505.
 Key-note, 1067.
 Keys—
 Capillary contact, 748.
 Friction, 748.
 Plug, 748.
 Kidney, 515.
 " blood of, 578.
 " chemistry of, 577.
 " conditions affecting, 582.
 " reabsorption in, 576.
 " structure of, 515.
 " volume of, 580.
 Kinæsthetic substance, 855.
 Kinetic energy, 422.
 " theory, 811.
 Klang, 1063, 1067.
 Knee phenomenon, 851.
 " reflex, 851.
 Kœnig's manometric flames, 1070.
 Koumiss, 468.
 Krause's end-bulbs, 1085.
 Kreatin, 513.
 Kreatinin, 513, 537.
 " properties, 537.
 " quantity, 537.
 " test, 537.
 Kresol, 514.
 Kymograph, 162.
 " Fick's, 164.
 " Ludwig's, 162.
 Kyphosis, 677.
Labials, 704.
 Labour, power of, 1162.
 Labyrinth, 1059.
 Lachrymal apparatus, 1039.
 Lacteals, 402.
 Lactic acid, 510, 545.
 " ferment, 335.
 Lactoprotein, 465.
 Lactose, 511, 562.
 Lævulose, 511.
 Lagophthalmus, 790.
 Lambert's method, 1011.
 Lamina spiralis, 1059.
 Laminae dorsales, 1125.
 Lanugo, 600.
 Large intestine, 377.
 " absorption in, 378.
 Lardacein, 503.
 Laryngoscope, 693.
 Larynx—
 Cartilages of, 686, 693.
 Experiments on, 696.
 Illumination of, 693.
 Mucous membrane of, 692.
 Muscles of, 689.
 View of, 694.
 Vocal cords, 687.
 Latent heat, 422.
 " period, 847.
 Lateral plates, 1128.
 Laughing, 249.
 Law of conservation of energy, xxvii.
 " contraction, 763, 776.
 " isolated conduction, 771.
 " peripheral perception, 1088, 1096.
 " specific energy, 952.
 Lecithin, 343, 367.
 Legumin, 472, 504.
 Lens, crystalline, 963.
 " chemistry of, 963.
 Lenticular nucleus, 935.
 Leptothrix buccalis, 275, 293.
 Leucic acid, 510.
 Lencin, 341, 375, 513, 563.
 Leucocytes, 402.
 Leucoderma, 783.
 Leukæmia, 23.
 Lichenin, 512.
 Lieberkühn's glands, 368, 390.
 Liebig's extract, 471.
 Life, xxxi.
 Liminal intensity, 952.
 Line of accommodation, 980.
 Ling's system, 677.
 Lingual nerve, 799.
 Lipaemia, 64.
 Liver, 346.

- Liver, chemical composition, 350.
 ,, cirrhosis of, 349.
 ,, fat in, 351.
 ,, functions of, 354.
 ,, glycogen in, 350.
 ,, pathology of, 349.
 ,, pulse in, 195.
- Locality, sense of, 1088.
 ,, illusions of, 1090.
- Lochia, 1162.
- Locomotor ataxia, 852, 858.
- Lordosis, 677.
- Loss of weight, 484.
 ,, by skin, 264.
- Löwe's ring, 995.
- Lungs, 215.
 ,, chemical composition of, 225.
 ,, development of, 1153.
- Lungs, elastic tension of, 227.
 ,, limits of, 242.
 ,, physical properties, 225.
 ,, structure of, 221.
 ,, tonus, 225.
- Lunule, 597.
- Lutein, 1116.
- Luxus consumption, 477.
- Lymph, 409, 413.
 ,, movement of, 415.
 ,, gases of, 266.
- Lymph-corpules, 409.
 ,, origin and decay of, 414.
- Lymphatics, 401.
 ,, of eye, 965.
 ,, origin of, 402.
- Lymph-follicles, 280, 323, 406.
 ,, glands, 406.
 ,, hearts, 417.
- Macropia**, 790.
- Macula lutea, 961.
- Macula acustica, 1061.
- Madder, feeding with, 496.
- Magnetisation, 743.
- Magneto-induction, 745, 747.
- Major chord, 1064.
- Malapterurus, 779.
- Maltose, 294, 340, 506, 511.
- Mammary glands, 461.
 ,, changes in, 462.
 ,, development of, 463.
 ,, structure of, 461.
- Manometer, 162.
- Manometric flames, 1070.
- Marey's tambour, 87, 132.
- Margarin, 596.
- Mariotte's experiment, 1002.
- Mastication, 299
 ,, muscles of, 299.
 ,, nerves of, 304.
- Massage, 677.
- Matter, xx.
- Maturation of ovum, 1121.
- Meat soup, 470.
- Meckel's cartilage, 1144.
 ,, ganglion, 97, 1143.
- Meconium, 367.
- Medulla oblongata—
 Functions of, 873.
 Grey matter of, 871.
 Reflex centres in, 874.
 Structure of, 870.
- Medullary groove, 1124.
 ,, tube, 1125.
- Meiocardie, 110.
- Meissner's plexus, 316, 392.
- Melanæmia, 23.
- Melanin, 508, 543.
- Melitose, 512.
- Mellitæmia, 65.
- Membrana decidua menstrualis, 1115.
 ,, flaccida, 1048.
 ,, reticularis, 1062.
 ,, reuniens, 1131.
 ,, secundaria, 1057.
 ,, tectoria, 1061.
- Membranes of brain, 946.
- Menière's disease, 812.
- Menstruation, 1113.
- Merkel's cells, 1086.
- Meroblastic ova, 1109.
- Mesentery, development of, 1153.
- Mesoblast, 1124, 1127.
- Mesonephros, 1157.
- Metabolic equilibrium, 476.
 ,, phenomena, 458.
- Metabolism, xxxi.
- Metalbumin, 502.
- Metallic tinkling, 244.
- Metalloscopy, 1097.
- Metamorphosis, 1101.
- Metanephros, 1157.
- Meteorism, 319.
- Methæmoglobin, 30.
- Methylamine, 513.
- Meynert's projection systems, 863.
 ,, theory, 906.
- Micrococci, 372.
- Micrococcus ureæ, 550.
- Microphone, 136.
- Micropyle, 1108.
- Micturition, 590.
 ,, centre for, 853.
- Migration of ovum, 1121.
- Milk, 462, 464.
 ,, coagulation of, 465.
 ,, colostrum, 466.
 ,, composition of, 466.
 ,, curdling ferment, 335, 344.
- Milk, digestion of, 334.
 ,, fever, 1163.
 ,, globules of, 464.
 ,, plasma, 465.
 ,, preparations of, 468.
 ,, sugar, 373, 465, 511.
 ,, tests for, 467.
- Millon's reagent, 333.
- Mimetic spasm, 809.
- Minor chord, 1064.
- Mixed colours, 1010.
- Molecules, xxi.
- Molecular basis of chyle, 410.
- Monoplegia, 929.
- Monospasm, 929.
- Moore's test, 297.
- Moreau's experiment, 371.
- Morphology, xix.
- Morula, 1122.
- Motor centres, dog, 916.
 ,, excision of, 918.
- Motor nerves, 781.
- Motor points on the surface, 773.
- Mouth, 279.
 ,, glands of, 279.
- Mouvement de manège, 940.
- Movements of the eye, 929.
 ,, forced, 940.
 ,, unco-ordinated, 828.
- Mucedin, 504.
- Mucigen, 388.
- Mucin, 504, 554, 964.
- Mucous tissue, 965.
- Mucous membrane currents, 752.
- Mucus, formation of, 273.
- Mulberry mass, 1122.
- Mulder's test, 297.
- Müller's ducts, 1155.
 ,, experiment, 149.
 ,, fibres, 961.
- Multiplicator, 735.
- Murexide test, 537.
- Murmurs, 192.
- Musca volitantes, 994.
- Muscarin, 313.
- Muscle, 614.
 ,, action of two stimuli on, 650.
 ,, action of veratrin, 650.
 ,, active, change in, 627.
 ,, arrangement of, 672.
 ,, atrophic proliferation of, 677.
 ,, blood-vessels of, 619.
 ,, cardiac, 621.
 ,, changes during contraction, 639, 643.
 ,, chemical composition, 625.
 ,, curve of, 646.

- Muscle, degenerations of, 678.
 ,, development of, 622.
 ,, effect of acids on, 632.
 ,, effect of cold on, 632.
 ,, effect of distilled water on, 631.
 ,, effect of exercise on, 628.
 ,, effect of fatigue on, 649.
 ,, effect of heat on, 631.
 ,, elasticity of, 661.
 ,, excitability of, 633.
 ,, extractives of, 628.
 ,, fatigue of, 667.
 ,, formation of heat in, 664.
 ,, glycogen in, 628.
 ,, involuntary, 622.
 ,, lymphatics of, 619.
 ,, metabolism of, 626.
 ,, myosin of, 625.
 ,, nerves of, 620.
 ,, nutrition of, 677.
 ,, perimysium of, 615.
 ,, physical characters, 624.
 ,, plasma of, 625.
 ,, polarized light on, 625, 641.
 ,, red and pale, 162, 653.
 ,, relation to tendons, 619.
 ,, rigor mortis of, 629.
 ,, serum of, 626.
 ,, smooth, 650.
 ,, sound of, 666.
 ,, spectrum of, 642.
 ,, stimuli of, 637.
 ,, structure of striped, 616.
 ,, tetanus, 652.
 ,, tonus, 854.
 ,, uses of, 672.
 ,, voluntary, 615.
 ,, work of, 658.
 Muscle-current, 740, 749.
 ,, theories, 757.
 Muscle-plate, 1131.
 Muscular contraction (see *Myogram*), rate of, 656.
 Muscular sense, 1098.
 ,, work, 658.
 ,, laws of, 659.
 Mutes, 703.
 Mydriasis, 789.
 Mydriatics, 991.
 Myelin forms, 344, 712.
 Myogram, 646.
 ,, effect of weights on, 649.
 ,, effect of fatigue on, 649.
- Myogram, effect of constant current on, 650.
 ,, method of studying, 648.
 ,, stages of, 647.
 Myograph, Helmholtz's, 643.
 ,, pendulum, 643.
 ,, Pflüger's, 646.
 ,, simple, 646.
 ,, spring, 645.
 Myopia, 982, 986.
 Myorocytes Weismann's, 624.
 Myosin, 502, 625.
 Myosis, 790.
 Myotics, 992.
- Nails, 597.**
 Nasal breathing, 248.
 ,, timbre, 702.
 Nasmyth's membrane, 301.
 Native albumins, 502.
 Natural selection, 1163.
 Near point, 981.
 Neef's hammer, 747.
 Negative accommodation, 976.
 ,, pressure, 395.
 ,, variation, 752, 754, 755.
 Nephrozymose, 545.
 Nerve-cells. bipolar, 717.
 ,, multipolar, 716.
 ,, of cerebrum, 861.
 ,, Purkinje's, 943.
 ,, with a spiral fibre, 717.
 Nerve centres, general functions, 835.
 Nerve-fibres, 707.
 ,, action of nitrate of silver on, 714.
 ,, chemical properties of, 718.
 ,, classification of, 781.
 ,, death of, 731.
 ,, degeneration of, 728.
 ,, development of, 716.
 ,, division of, 714.
 ,, effect of a constant current on, 724.
 ,, electrical current of, 740.
 ,, excitability of, 720.
 ,, fatigue of, 726.
 ,, incisures of, 714.
 ,, mechanical properties of, 719.
 ,, medullated, 711.
 ,, metabolism of, 720.
 ,, nutrition of, 726.
 ,, Ranvier's nodes, 713.
 ,, reaction of, 719.
 ,, regeneration of, 729.
 ,, sheaths of, 715.
- Nerve-fibres, stimuli of, 721.
 ,, structure of, 709.
 ,, suture of, 729.
 ,, terminations of, 1086.
 ,, to glands, 286.
 ,, traumatic degeneration of, 729.
 ,, trophic centres of, 730.
 ,, unequal excitability of, 725.
 Nerves, cranial, 784.
 ,, intercentral, 784.
 ,, motor, 781.
 ,, secretory, 781.
 ,, sensory, 783.
 ,, special sense, 783.
 ,, spinal, 825.
 ,, trophic, 781.
 ,, union of, 771.
 Nerve-current, 740, 759.
 Nerve-impulse, rate of, 766.
 ,, method of measuring, 767.
 ,, modifying conditions, 767.
 ,, variations of, 770.
 Nerve-motion, 770.
 Nerve-muscle preparation, 754.
 Nerve-stretching, 721.
 Nervi nervorum, 716.
 Nervous system, 709, 835.
 ,, development of, 1159.
 Nervus abducens, 803.
 ,, accessorius, 823.
 ,, acusticus, 809.
 ,, depressor, 169, 817.
 ,, erigens, 900, 1117.
 ,, facialis, 804.
 ,, glossopharyngeus, 813.
 ,, hypoglossus, 824.
 ,, oculomotorius, 788.
 ,, olfactorius, 784.
 ,, opticus, 785.
 ,, sympathicus, 830.
 ,, trigeminus, 790.
 ,, trochlearis, 790.
 ,, vagus, 814.
 Neubauer's test, 297.
 Neuralgia, 802, 1097.
 Neural tube, 1125.
 Neurasthenia gastrica, 381.
 Neurin, 718.
 Neuro-epithelium, 960.
 Neurogleia, 839.
 Neuro-keratin, 714.
 Neuro-muscular cells, 637.
 New-born child, digestion of, 344.
 ,, food of, 481.
 ,, mental faculties, 954.
 ,, pulse, 142.

- New-born child, size, 497.
 ,, temperature, 438.
 ,, urine of, 525.
 ,, weight, 497.
 Nictitating membrane, 1041.
 Nitrogen in air, 245.
 ,, in blood, 58.
 ,, given off, 477.
 Nœud vital, 876.
 Noises, 1063.
 Nœse, development of, 1161.
 ,, structure, 1077.
 Notochord, 1127.
 Nuclein, 504.
 Nucleus of Pander, 1100.
 Nutrient arteries, 949.
 ,, enmata, 400.
 Nussbaum's experiments, 574.
 Nyctalopia, 788.
 Nystagmus, 790, 811, 941.
- Cculomotorius**, 788.
 Odontoblasts, 302.
 Œdema, 419.
 ,, cachetic, 420.
 ,, pulmonary, 75, 248.
- Œsophagus, 308.
 Oleic acid, 509.
 Oligæmia, 63.
 Olfactory centre, 923, 933.
 ,, nerve, 784.
 ,, sensations, 1078.
 Ohm's law, 733.
 Oidium albicans, 275, 293.
 Omphalo-mesenteric duct, 1129.
 ,, ,, vessels, 1130, 1151.
- Onomatopoesy, 706.
 Oncograph, 209, 581.
 Oncometer, 581.
 Ontogeny, 1164.
 Opening shock, 743.
 Ophthalmia neuro-paralytica, 796.
 ,, intermittens, 797.
 ,, sympathetic, 797.
 Ophthalmic nerve, 792.
 Ophthalmometer, 974.
 Ophthalmoscope, 997, 1000.
 Optic nerve, 785, 996.
 ,, radiation, 785.
 ,, thalamus, 936.
 ,, tract, 785.
 ,, vesicle, 1126.
 Optical cardinal points, 970.
 Optogram, 1009.
 Optometer, 984.
 Organic compounds, 500.
 ,, reflexes, 852.
- Organ-albumin, 477.
 Orthoscope, 1002.
 Osomasome, 470.
 Ossein, 505.
 Osseous system, formation of, 1141.
 Osteoblasts, 1146.
 Osteoclasts, 1147.
 Osteomalacia, 677.
 Otic ganglion, 800.
 Ovary, 1106.
 Ovarian tubes, 1108.
 Ovulation, 1114.
 ,, theories of, 1115.
 Ovum, 1107.
 ,, development of, 1108.
 ,, discharge of, 1114.
 ,, fertilisation of, 1120.
 ,, impregnation of, 1122.
 ,, maturation of, 1121.
 ,, migration of, 1121.
 ,, structure of, 1107.
- Oxalic acid, 539.
 ,, series, 510.
 Oxaluria, 540.
 Oxaluric acid, 539.
 Oxyhæmoglobin, 29.
 Oxyakoia, 808.
- Pacchionian** bodies, 947.
 Pacini's corpuscles, 1085.
 Pain, 1096.
 ,, irradiation of, 859.
 Painful impressions, conduction of, 858.
 Palmitic acid, 509.
 Pancreas, 337.
 ,, changes in, 338.
 ,, development of, 1153.
 ,, fistula of, 339.
 ,, juice of, 339.
 ,, paralytic secretion, 339, 345.
- Pancreatic secretion, 340.
 ,, actions of, 341, 344.
 ,, artificial juice, 341.
 ,, action of nerves on, 345.
 ,, action of poisons on, 345.
 ,, composition, 340.
 ,, extracts, 344.
- Panophthalmia, 795.
 Pansphygmograph, 132.
 Papain, 342.
 Papilla foliata, 1083.
 Parabanic acid, 539.
 Parablastic cells, 1128.
 Paradoxical contraction, 757.
- Paradoxical reaction, 810.
 Paraglobulin, 44, 49, 502.
 Parakresol, 514, 544.
 Paralbumin, 502.
 Paralgia, 1097.
 Paralytic secretion of saliva, 288.
 ,, pancreatic juice, 345.
- Paramylum, 512.
 Parapeptone, 331.
 Paraphasia, 932.
 Paraxanthin, 514, 539.
 Paraleptonomy, 757.
 Paridrosis, 609.
 Paroöphoron, 1157.
 Parotid gland, 284, 289.
 Parovarium, 1156.
 Parthenogenesis, 1102.
 Partial pressure, 52.
 ,, reflexes, 843.
- Particles, xxi.
 Parturition, centre for, 853.
 Passavant's elevation, 306.
 Passive insufficiency, 675.
 Patellar reflex, 852.
 Pathic reflex, 849.
 Pavy's test, 560.
 Pecten, 1041.
 Pectoral fremitus, 246.
 Pedunculi cerebri, 939.
 Penis, erection of, 1116.
 Pepsin, 325, 331, 545.
 Pepsinogen, 327.
 Peptic glands, 321.
 ,, changes in, 326.
 Peptone, 331, 341.
 ,, forming ferment, 296.
 ,, tests for, 332.
- Peptonised foods, 345. ;
 Peptonuria, 554.
 Percussion, 242.
 Pericardium, 71.
 Perimeter, Aubert and Forster, 1005.
 ,, M'Hardy's, 1005.
 ,, Priestley Smith's, 1007.
- Perimetric chart, 1007.
 Perimetry, 1005.
 Perineurium, 715.
 Periodontal membrane, 301.
 Peristaltic movement, 305, 312.
 ,, action of blood on, 318.
 ,, action of nerves on, 319.
- Peritoneum, development of, 1153.
 Perivascular spaces, 404.
 Pectenkofer's test, 356, 559.

- Peyer's glands, 391.
 Pflüger's law, 844.
 Phakoscope, 979.
 Phänakistoscope, 1018.
 Phases, displacement of, 1063.
 Phenol, 341, 376, 510, 514, 544.
 Phenylsulphuric acid, 514.
 Phlebogram, 194.
 Phonation, 691.
 Phonograph, 1069.
 Phonometry, 244.
 Phosphenes, 995.
 Photophobia, 809.
 Photopsia, 788.
 Phrenograph, 231.
 Phrenology, 904.
 Phylogeny, 1164.
 Phycomycetes, 565.
 Pia mater, 946.
 Picric acid test, 553.
 Pitch, 1063.
 Placenta, 1137.
 Placental bruit, 192.
 Plantar reflex, 850.
 Plants, characters of, xxviii.
 " electrical currents in, 760.
 Plasma cells, 947.
 " of blood, 38.
 " of lymph, 409.
 " of milk, 465.
 " of muscle, 625.
 Plethora, 61.
 Plethysmography, 197.
 Pleura, 223.
 Pleuro-peritoneal cavity, 1128.
 Pleximeter, 242.
 Pneumatogram, 229.
 Pneumograph, 231.
 Pneumonia after section of vagi, 819.
 Pneumothorax, 226.
 Poikilothermal animals, 426.
 Poiseuille's space, 187.
 Poisons, heart, 109.
 " spinal cord, 845, 847.
 " on vasomotor nerves, 898.
 Polar globules, 1121.
 Polarisation, galvanic, 737.
 " internal, 742.
 Polarising after-currents, 757.
 Politzer's ear bag, 1057.
 Polyæmia, 61, 62.
 " apocoptica, 61.
 " aquosa, 62.
 " hyperalbuminosa, 62.
 " polycythæmica, 62.
 Polyæmia, serosa, 62.
 " transfusoria, 61.
 Polyopia monocularis, 989.
 Pons Varolii, 939.
 Porret's phenomenon, 624.
 Portal canals, 346.
 " circulation, 65.
 " system, development of, 1152.
 " vein in liver, 316.
 " vein, ligature of, 176.
 Positive accommodation, 976.
 " after images, 1018.
 Potash salts, 108, 560, 584, 667, 677.
 Potassium sulphocyanide, 291, 545.
 Potatoes, 472.
 Presbyopia, 983.
 Pressor fibres, 859, 893.
 Pressure, arterial, 162.
 " intra-labyrinthine, 1062.
 " sense of, 1091.
 Prickle cells, 595.
 Primitive anus, 1133.
 " chorion, 1123.
 " circulation, 1130.
 " groove, 1123.
 " kidneys, 1154.
 " mouth, 1133.
 " streak, 1123.
 Primordial cranium, 1142.
 " ova, 1108.
 Principal focus, 967.
 " point, 970.
 Progressive muscular atrophy, 782.
 Pronephros, 1156.
 Pronucleus, male, 1122.
 " female, 1122.
 Propeptone, 331.
 Protagon, 508, 719.
 Proteids, 500.
 " gastric digestion of, 331.
 " fermentation of, 375.
 " pancreatic digestion of, 341.
 " reactions of, 501.
 Protistæ, xix.
 Protodæum, 1124.
 Protoplasm, 759.
 Protovertebræ, 1128.
 Pseudo-hypertrophic paralysis, 782.
 Pseudo-motor action, 806.
 Pseudoscope, 1035.
 Pseudo-stomata, 221.
 Psychological activities, 903.
 " blindness, 921, 933.
 " deafness, 922.
 Psycho-acoustic centre, 922, 933.
 " geusic centre, 923, 933.
 " motor centres, 914.
 " optic centre, 785, 921, 932.
 " osmic centre, 923.
 " physical law, 953.
 " sensorial centres, 920.
 " sensory paths, 934.
 Ptomaines, 333.
 Ptoxis, 789.
 Ptyalin, 293, 295, 506.
 Puberty, 1112.
 Pulmonary artery, pressure in, 177.
 Pulmonary œdema, 248.
 Pulse, 127.
 " anacrotism of capillary, 196.
 " characters of, 141.
 " conditions affecting, 142.
 " curve, 136.
 " dicrotic, 140.
 " optological, 156.
 " historical, 127.
 " influence of pressure on, 151.
 " influence of respiration on, 148.
 " instruments for investigating, 128.
 " of various arteries, 144.
 " paradoxical, 151.
 " pathological, 157.
 " recurrent, 146.
 " trigeminus, 143.
 " variations in, 142.
 " venous, 195.
 " wave, 152.
 Pulsus alternans, 143.
 " bigeminus, 143.
 " capricans, 140.
 " dicrotus, 140.
 " intercurrens, 143.
 " myurus, 143.
 Pumping mechanisms, 415.
 Pupil, 980.
 " action of poisons on, 991.
 " Argyll Robertson, 991.
 " functions of, 989.
 " movements of, 990.
 " photometer, 993.
 " size of, 980, 993.
 Purgatives, 320.
 Purkinje, cells of, 943.
 " fibres of, 73.
 " figure, 995.
 Putrefactive processes, 371.
 Pyloric glands, 322.

- Pyloric glands, changes in, 326.
 Pyramidal tracts, 867.
 " degeneration of, 927.
 Pyuria, 564.
 Pyrokatechin, 510, 544.
Quality of a note, 1063, 1067.
 Quantity of blood, 60.
 " food, 478, 480.
Rales, dry, 246.
 " moist, 246.
 Rami communicantes, 830.
 Range of accommodation, 987.
 Ranvier's nodes, 713.
 Reaction of degeneration, 774, 777.
 Reaction time, 770, 907.
 Recovery, 668, 726.
 Recurrent pulse, 146.
 " sensibility, 826.
 Red-blindness, 1016.
 Reduced eye of Listing, 972.
 Reductions in intestine, 377.
 Reflex acts, examples of, 845.
 " movement, 843.
 " movements, theory of, 849.
 " nerves, 783.
 " spasms, 843.
 " tactile, 857.
 " time, 847.
 " tonus, 854.
 Refracted ray, 971.
 Refractive indices, 969.
 Regeneration of tissues, 493.
 " nerve, 729.
 Regio olfactoria, 1077.
 " respiratoria, 1077.
 Reissner's membrane, 1060.
 Relative proportions of diet, 480.
 Renal plexus, 579.
 Rennet, 335, 466.
 Reproduction, forms of, 1100.
 Requisites in a proper diet, 478.
 Reserve air, 227.
 Residual air, 227.
 Resistance, 117.
 Resonance organs, 707.
 Resonants, 703.
 Resorcin, 544.
 Respiration, 217.
 " amphoric, 246.
 " artificial, 271, 883.
 Respiration, bronchial, 245.
 " centre for, 876.
 " chemistry of, 250.
 " cog-wheel, 246.
 " forced, 232, 247.
 " in a closed space, 267.
 " intestinal, 277.
 " muscles of, 234.
 " number of, 229.
 " periodic, 234.
 " pressure during, 247.
 " sounds of, 245.
 " time of, 229.
 " type, 232.
 " variations of, 233.
 " vesicular, 245.
 Respiratory apparatus, 217, 251.
 " Andral and Gavarret, 251.
 " mechanism of, 226.
 " v. Pettenkofer, 253.
 " Regnault and Reiset, 252.
 " Scharling, 252.
 Respiratory centre, 876.
 " quotient, 255.
 Rete mirabile, 66.
 Retina, 960.
 " activity in vision, 1002.
 " blood-vessels of, 961.
 " chemistry of, 962.
 " capillaries, movements in, 995.
 " epithelium of, 961.
 " rods and cones of, 1003.
 " structure of, 960.
 " visual purple of, 961.
 Retinal image, formation of, 973.
 " size of, 973, 1035.
 Retinoscopy, 1000.
 Rigor mortis, 629.
 Rheocord, 732.
 Rheometer, 181.
 Rheophores, 772.
 Rheoscopic limb, 751.
 Rheostat, 734.
 Rhinoscopy, 696.
 Rhodophane, 963.
 Rhodopsin, 961, 1009.
 Rickets, 677.
 Ritter's opening tetanus, 766.
 " tetanus, 763.
 Ritter-Valli law, 731, 764.
 Rods and cones, 1002.
 Rotatory disc for colours, 1011.
 Running, 683.
Saccharomycetes, 565.
 Saccharose, 511.
 Saftcänälchen, 402.
 Saline cathartics, 320.
 Saliva, action of poisons on, 290.
 " action on starch, 294, 296.
 " composition of, 292.
 Saliva facial,
 " functions of, 294.
 " mixed, 292.
 " new-born child, 293.
 " parotid, 291.
 " pathological, 380.
 " ptyalin, 295.
 " reflex secretion of, 289.
 " sublingual, 292.
 " submaxillary, 292.
 " theory of secretion, 291.
 Salivary corpuscles, 292.
 " development of, 1153.
 " glands, 280.
 " nerves of, 285.
 Salts, 499.
 Sanson-Purkinje's images, 978.
 Saponification, 343.
 Sarcina ventriculi, 381.
 Sarcolactic acid, 626.
 Sarkin, 514, 539.
 Sarkosin, 513.
 Saviotti's canals, 338.
 Scheiner's experiment, 980.
 Schiff's test, 538.
 Schizomycetes, 372, 565.
 Schreger's lines, 301.
 Schwann's sheath, 713.
 Sclerotic, 958.
 Scoliosis, 677.
 Scotoma, 1007.
 Screw-hinge joint, 670.
 Scrotum, formation of, 1157.
 Scyllit, 513.
 Sebaceous glands, 601.
 " secretion, 604.
 Seborrhœa, 610.
 Secondary contraction, 753.
 " degeneration, 841.
 " tetanus, 754.
 Secretion currents, 759.
 Secretory nerves, 781.
 Sectional area, 182.
 Segmentation sphere, 1122.
 Self-stimulation of muscle, 751.

- Semen, composition of, 1102.
 ,, ejaculation of, 1119.
 ,, reception of, 1119.
 Semicircular canals, 810, 1060.
 Sense organs, 952.
 Sensory areas, 923.
 Serin, 513.
 Serum of blood, 38.
 Serum-albumin, 49, 502, 551.
 Serum-globulin, 44, 49, 502.
 Setschenow's centres, 848.
 Sex, difference of, 1158.
 Shadows, 994.
 ,, coloured, 1021.
 Sharpey's fibres, 301, 1147.
 Short-sightedness, 982, 986.
 Shunt, 741.
 Sighing, 249.
 Simple colours, 1010.
 ,, contraction, 646.
 Simultaneous contrast, 1020.
 Single vision, 1029.
 Sitting, 680.
 Size, 497.
 ,, estimation of, 1035.
 ,, false estimate of, 1038.
 Skatol, 341, 376, 414, 545.
 Skin, absorption by, 610.
 ,, chorium of, 596.
 ,, comparative, 611.
 ,, epidermis, 593.
 ,, functions of, 602.
 ,, galvanic conduction of, 616.
 ,, glands of, 601.
 ,, historical, 611.
 ,, protective covering, 602.
 ,, respiratory organ, 603.
 ,, structure of, 593.
 ,, varnishing the, 604.
 Skin currents, 752.
 Sleep, 908, 948, 991.
 Small intestine, 386.
 ,, absorption by, 395.
 ,, structure of, 387.
 Smegma, 604.
 Smell, 784.
 ,, sense of, 1077.
 Sneezing, 249.
 Snellen's types, 984.
 Snoring, 249.
 Sodie chloride, 499, 546.
 Solitary follicles, 390.
 Somatopleure, 1128.
 Sorbin, 513.
 Sound, 1045.
 ,, conduction to ear, 1044.
 ,, direction of, 1075.
 ,, distance of, 1075.
 ,, heart, 91.
 ,, of muscle, 666.
 ,, perception of, 1075.
 ,, reflection of, 1045.
 Spasm centre, 901.
 Spasmus nictitans, 809.
 Specific energy, 952, 1008.
 Spectacles, 986.
 Spectra, optical, 997.
 Spectroscope, 27, 557.
 Spectrum mucro-lacrimale, 994.
 ,, of bile, 358.
 ,, of blood, 29.
 ,, of muscle, 642.
 Speech, 699.
 ,, centre for, 929.
 ,, pathological variations, 705.
 Spermatin, 1103.
 Spermatozoa, 1103.
 Spina bifida, 1131.
 Spinal accessory nerve, 823.
 Spinal cord, 835.
 ,, action of blood and poisons on, 856.
 ,, anterior roots of, 828.
 ,, blood-vessels of, 839.
 ,, centres, 852.
 ,, conducting paths in, 856.
 ,, conducting system of, 840.
 ,, development of, 1160.
 ,, degeneration of, 841.
 ,, excitability of, 854.
 ,, Flechsig's systems, 804.
 ,, ganglion, 825.
 ,, Gerlach's theory, 838.
 ,, nerves, 825.
 ,, neurogleia of, 839.
 ,, nutritive centres in, 841.
 ,, posterior roots of, 830.
 ,, reflexes, 843.
 ,, regeneration of, 902.
 ,, secondary degeneration of, 841.
 ,, segment of, 867.
 ,, structure of, 835.
 ,, time of development, 842.
 Spinal cord, transverse section of, 860.
 ,, unilateral section of, 860.
 ,, vaso-motor centres in, 897.
 ,, Woroschiloff's observations, 837.
 Spheno-palatine ganglion, 797.
 Spherical aberration, 988.
 Sphincters, 673.
 Sphincter ani, 314.
 ,, pupille, 789, 959.
 ,, urethrae, 588.
 Sphygmograph, 129.
 ,, Dudgeon's, 131.
 ,, Marey's, 129.
 Sphygmometer, 128.
 Sphygmogram, 136.
 Spiral joints, 670.
 Spirillum, 372.
 Spirochaeta, 372.
 Spirometer, 227.
 Splanchnic nerve, 319, 897.
 Splanchnopleure, 1128.
 Spleen, 203.
 ,, chemical composition, 206.
 ,, contraction of, 208.
 ,, extirpation of, 207.
 ,, functions of, 207.
 ,, influence of nerves on, 210.
 ,, oncograph, 209.
 ,, structure, 203.
 ,, tumours of, 211.
 Spongion, 505.
 Spontaneous generation, 1100.
 Spores, 372.
 Spring-kymograph, 164.
 ,, myograph, 645.
 Sputum abnormal, 275.
 ,, normal, 273.
 Squint, 804.
 Stammering, 706.
 Standing, 679.
 Stannius experiment, 100.
 Stapedius, 1054.
 Starch, 512.
 ,, animal, 350.
 Stasis, 190.
 Statical theory of Goltz, 811.
 Stationary vibrations, 1045.
 Steapsin, 343.
 Stenopaic spectacles, 987.
 Stenson's experiment, 630.
 Stereoscope, 1034, 1037.
 Stereoscopic vision, 1031.
 Stethograph 229, 231.
 Stigmata, 122.
 Stilling, canal of, 965.

- Stimuli, 633.
 " adequate, 952.
 " homologous, 952.
 " heterologous, 952.
 Stoffwechsel, xxxi.
 Stomach, 309.
 " catarrh of, 381.
 " changes in glands, 326.
 " diseases of, 380.
 " glands of, 322.
 " movements of, 309.
 " structure of, 321.
 Stomata, 122, 405.
 Stomodæum, 1124.
 Storage albumin, 485.
 Strabismus, 941.
 Strangury, 592.
 Stroma-fibrin and plasma-fibrin, 48.
 Struggle for existence, 1163.
 Strychnin, action of, 845.
 Stuttering, 706.
 Subarachnoid space, 947.
 Subdural space, 947.
 Subjective sensations, 954.
 Sublingual gland, 289.
 Submaxillary ganglion, 285, 802.
 " atropin on, 288.
 " gland, 286.
 " saliva,
 Successive beats, 1064.
 " contrast, 1022.
 Succinic acid, 545.
 Succus entericus, 368.
 Suction, 298.
 Sugars, 510, 546.
 Sulphindigotate of soda, 574.
 Summation of stimuli, 844.
 Superfecundation, 1120.
 Superficial reflexes, 850.
 Superfœtation, 1120.
 Superior maxillary nerve, 797.
 Supra-renal capsules, 213.
 Surditas verbalis, 933.
 Sutures, 672.
 Sweat, 604.
 " chemical composition, 605.
 " conditions influencing secretion, 660.
 " excretion of substances by, 606.
 " glands, 601.
 " insensible, 605.
 " nerves, 606.
 " pathological variations of, 609.
 Sweat centre, 607, 902.
 " spinal, 855.
 Swimming, 684.
 Sympathetic ganglion, 830.
 " nerve, 830.
 Sympathetic nerve, section of, 833.
 " stimulation of, 795.
 Synchondroses, 672.
 Synergetic muscles, 676.
 Synovia, 669.
 Syntonin, 331, 503.
 Tâches cerebrales, 899.
 Tactile areas, 934.
 " corpuscles, 1086.
 " sensations, conduction of, 857.
 Tænia, 1102.
 Tail-fold, 1129.
 Talipes, calcaneus, 677.
 " equinus, 677.
 " varus, 677.
 Tapetum, 1001.
 Tapping experiment, 885.
 Taste-bulbs, 1080.
 " organ of, 1080.
 " testing, 1083.
 Taurin, 513.
 Taurocholic acid, 355.
 Tea, 473.
 Tears, 1039.
 Tegmentum, 865.
 Telestereoscope, 1034, 1037.
 Temperature of animals, 427.
 " accommodation for, 448.
 " artificial increase of, 452.
 " estimation of, 427.
 " how influenced, 432.
 " lowering of, 455.
 " post-mortem, 453.
 " regulation of, 441.
 " topography of, 430.
 " variations of, 437.
 Temperature-sense, 1094.
 " illusions of, 1095.
 Tendon, 619.
 " nerves of, 624, 1087.
 " reflexes, 851.
 Tensor, choroideæ, 958.
 " tympani, 1052.
 Terminal arteries, 949.
 Testicle, descent of, 1156.
 Tetanomotor, 722.
 Tetanus, 652, 725.
 Thaumatrope, 1018.
 Theobromin, 473.
 Thermal cortical centre, 924, 932.
 Thermo-electric methods, 428.
 " needles, 429.
 Thermometer, 427.
 " metastatic, 427.
 " outflow, 427.
 Thermometry, 427.
 Thirst, 1096.
 Thiry's fistula, 370.
 Thomsen's disease, 651.
 Thoraco-meter, 241.
 Thymus, 211.
 " development of, 1144.
 Thyroid, 213.
 " development of, 1144.
 Tibial nerve, 894.
 Tidal air, 227.
 Timbre, 1063, 1067.
 Time in psychical processes, 907.
 Time-sense, 1066.
 Tinnitus, 810.
 Tissue metabolism, 490.
 Tomes, fibres of, 300.
 Tone-inductorium, 655.
 Tones, 1063.
 Tongue, glands of, 279.
 " movements of, 304.
 " structure of, 280.
 " taste-bulbs of, 1080.
 Tonsils, 280.
 Tooth, 300.
 " chemistry of, 302.
 " development of, 302.
 " eruption of, 304.
 " permanent, 304.
 " pulp of, 302.
 " structure of, 300.
 " temporary, 304.
 Toricelli's theorem, 115.
 Torpedo, 779.
 Torticollis, 823.
 Touch corpuscles, 1083.
 Touch, sense of, 1083.
 Trachea, 217.
 Transfusion, 199.
 " of blood, 199.
 " of other fluids, 202.
 Transitional epithelium, 587.
 Transplantation of tissues, 497.
 Trapezius, spasm of, 823.
 Traube-Hering curves, 171.
 Traumatic degeneration of nerves, 729.
 Trichina, 1102.
 Trigeminus, 790.
 " ganglia of, 793, 797, 800, 802.
 " inferior maxillary branch, 797.
 " neuralgia of, 802.
 " ophthalmic branch, 792.
 " paralysis of, 802.
 " pathological, 802.
 " section of, 803.
 " superior maxillary branch, 797.
 " trophic functions of, 803.

- Triple phosphate, 550.
 Trismus, 802.
 Trochlearis, 790.
 Trommer's test, 297.
 Trophic centres, 730.
 " fibres, 795.
 " nerves, 728, 781.
 Trophoneuroses, 782.
 Trotting, 683.
 Trypsin, 341.
 Trypsinogen, 343.
 Tryptone, 341.
 Tube casts, 565.
 Tubes, capillary, 118.
 " division of, 118.
 " elastic, 118.
 " movements of fluids in, 118.
 " rigid, 125.
 " unequal diameter, 117.
 Tumultus sermoris, 932.
 Tunica, 512.
 Türk's method, 849.
 Twitch, 646.
 Tympanic membrane, 1046.
 " artificial, 1049.
 Tyrosin, 341, 375, 513, 563.
Ulcer of foot, perforating, 783.
 Unipolar induction, 745.
 " stimulation, 725.
 Umbilical arteries, 1134.
 " cord, 1138.
 " veins, 1130, 1152.
 " vesicle, 1129.
 Upper tones, 1067.
 Urachus, 1135.
 Uremia, 584.
 Urates, 537.
 Urea, 513, 530.
 " compounds of, 532.
 " decomposition of, 530.
 " effect of exercise on, 531.
 " formation of, 532.
 " nitrate of, 532.
 " occurrence of, 532.
 " oxalate of, 533.
 " pathological, 531.
 " phosphate of, 533.
 " preparation of, 532.
 " properties of, 530.
 " qualitative estimation of, 533.
 " quantitative estimation of, 533.
 " quantity of, 530.
 " relation of, to muscular work, 629.
 Ureter, ligature of, 576.
 " structure and functions of, 585.
 Uric acid, 534.
 " diathesis, 535.
 Uric acid, formation of, 534.
 " occurrence, 536.
 " properties of, 534.
 " quality, 534.
 " qualitative estimation, 537.
 " quantitative estimation, 538.
 " solubility, 534.
 " tests for, 537, 538.
 Urinary bladder, 586.
 " calculi, 568.
 " closure of, 588.
 " deposits, 567.
 " development of, 1154.
 " organs, 515.
 " pressure in, 591.
 Urine, 515, 525.
 " abnormal conditions of, 584.
 " accumulation of, 589.
 " acid fermentation, 548.
 " albumin in, 551.
 " alkaline fermentation, 549.
 " amount of solids, 525.
 " bases in, 548.
 " bile in, 558.
 " blood in, 555.
 " calculi, 568.
 " changes of in bladder, 591.
 " colour, 527.
 " colouring matters of, 542.
 " consistence, 528.
 " cystin in, 562.
 " deposits in, 564.
 " effect of blood-pressure on, 571.
 " egg-albumin in, 554.
 " electrical condition of, 778.
 " excretion of pigments by, 575.
 " extractives in, 543.
 " fermentations of, 548.
 " fluorescence, 528.
 " fungi in, 565.
 " gases in, 548.
 " globulin in, 554.
 " incontinence of, 592.
 " influence of nerves on, 579.
 " inorganic constituents, 546.
 " inosit in, 562.
 " lencin in, 563.
 " milk-sugar in, 562.
 " movement of, 585.
 " mucin in, 554.
 " mucus in, 528.
 " passage of substances into, 578.
 Urine, peptone in, 554.
 " phosphoric acid in, 546.
 " physical characters of, 525.
 " pigments of, 508.
 " preparation of, 576.
 " propeptone in, 554.
 " quantity, 525.
 " reaction, 529.
 " retention of, 592.
 " secretion of, 570.
 " silicic acid in, 548.
 " sodic chloride in, 546.
 " specific gravity, 525.
 " spontaneous changes in, 548.
 " sugar in, 559.
 " sulphuric acid in, 547.
 " taste of, 529.
 " test for albumin in, 552.
 " tube casts in, 565.
 " tyrosin in, 563.
 Urinometer, 526.
 Urobilin, 358, 542.
 Urochrome, 542.
 Uroerythrin, 542.
 Uroglaucin, 542.
 Uromelanin, 542.
 Urostealth, 569.
 Uterine milk, 1137.
 Uterus, 1111.
 " development of, 1156.
 " involution of, 1163.
 " nerves of, 1162.
 Uvea, 958.
Vagus, 814.
 " cardiac branches, 818.
 " depressor nerve of, 817.
 " effect of section, 819.
 " pathological, 822.
 " pneumonia after section, 819.
 " reflex effects of, 821.
 " stimulation of, 822.
 " unequal excitability of, 821.
 Valleix's points douloureux, 1097.
 Valsalva's experiment, 149, 1055.
 Valve, ileo-colic, 312.
 " pyloric, 309.
 Valves, of heart, 72.
 " disease of, 91.
 " injury to, 80.
 " of veins, 123.

- Valves, sounds of, 194.
 Valvulæ conniventes, 386.
 Varicose fibres, 711.
 Varix, 176.
 Varnishing the skin, 456.
 Varnix caseosa, 604.
 Vasa vasorum, 124.
 Vascular system, develop-
 ment of, 1148.
 Vaso-dilator centre, 890.
 „ nerves, 890.
 Vaso-motor centre, 890.
 „ spinal, 854.
 Vaso-motor nerves, course
 of, 892.
 Vater's corpuscles, 1085.
 Vegetable albumin, 504.
 „ casein, 504.
 „ foods, 479.
 Veins, 123.
 „ cardinal, 1150.
 „ development of,
 1150.
 „ movement of blood
 in, 190.
 „ murmurs in, 193.
 „ pulse in, 194.
 „ structure of, 123.
 „ tonus of, 892, 899.
 „ valves in, 123.
 „ valvular sounds in,
 194.
 „ varicose, 176.
 „ velocity of blood in,
 182.
 Ventilation, 272.
 Ventricles, 69, 79, 161.
 „ capacity of, 161.
 „ duration of, 184.
 Veratrin, 730.
 Vertebrae, mobility of, 679.
 Vertebral column, 1131.
 Vertigo, 813.
 Vibratives, 703.
 Vibrio, 372.
 Villus intestinal, 387.
 „ absorption by, 398.
 „ contractility of, 395.
 Villus, chorionic, 1123.
 „ placental, 1137.
 Violet-blindness, 1016.
 Visceral arches, 1132.
 „ clefts, 1132.
 Vision, binocular, 1028.
 „ single, 1029.
 „ stereoscopic, 1031.
 Visual angle, 973, 1035.
 „ cells, 960.
 „ purple, 961, 1009.
 Vital capacity, 227.
 Vitellin, 502.
 Vitelline duct, 1129.
 Vitreous humour, 964.
 Vocal cords, 687, 691.
 „ conditions influ-
 encing the, 697.
 „ varying conditions
 of, 695.
 Voice, falsetto, 698.
 „ in animals, 707.
 „ pathological varia-
 tions of, 705.
 „ physics of, 685.
 „ pitch of, 686.
 „ production of, 698.
 „ range of, 699.
 Voluntary motor fibres, 866.
 „ movements local-
 ised, 857.
 Vomiting, 310, 345.
 „ centre for, 311.
 Vowels, analysis of, 1068.
 „ artificial, 1068.
 „ formation of, 700.
 „ Koenig's apparatus
 for, 1071.
 Waking, 908.
 Walking, 681, 683.
 Wallerian law of degenera-
 tion, 728.
 Warm-blooded animals,
 426.
 Water, 499.
 „ absorbed by skin, 610.
 „ absorption of, 386.
 Water, amount of, 458.
 „ exhaled by skin, 264,
 605.
 „ exhaled from lungs,
 256.
 „ hardness of, 459.
 „ impurities, 460.
 „ in urine, 525.
 „ vapour of, in air, 254.
 Wave-pulse, 136.
 „ propagation of, 153.
 Wave-movements, 1045.
 Waves, in elastic tubes,
 118, 153.
 Weber's paradox, 663.
 „ law, 953.
 Weight, 497.
 White of egg, 501.
 Wine, 475.
 Wolffian bodies, 1157.
 „ ducts, 1134, 1154.
 Word-blindness, 933.
 Word-deafness, 933.
 Work, xxiii.
 „ unit of, xxiii.
 Xanthin, 341, 514, 539.
 Xanthokyanopy, 1016.
 Xanthophane, 963.
 Xanthoprotein, reaction,
 501.
 Yawning, 249.
 Yeast, 474.
 Yolk, 1100.
 „ sac, 1129.
 Yellow spot, 961.
 Young-Helmholtz theory,
 1013.
 Zimmermann, particles
 of, 22.
 Zinn, zonule of, 963.
 Zöllner's lines, 1038.
 Zona pellucida, 1107.
 Zoogloea, 372.
 Zymogen, 327, 342.
 Zymophytes, 335.

THE END.



QP34

L232

Landois

v.2

A manual of human

