

NYPL RESEARCH LIBRARIES

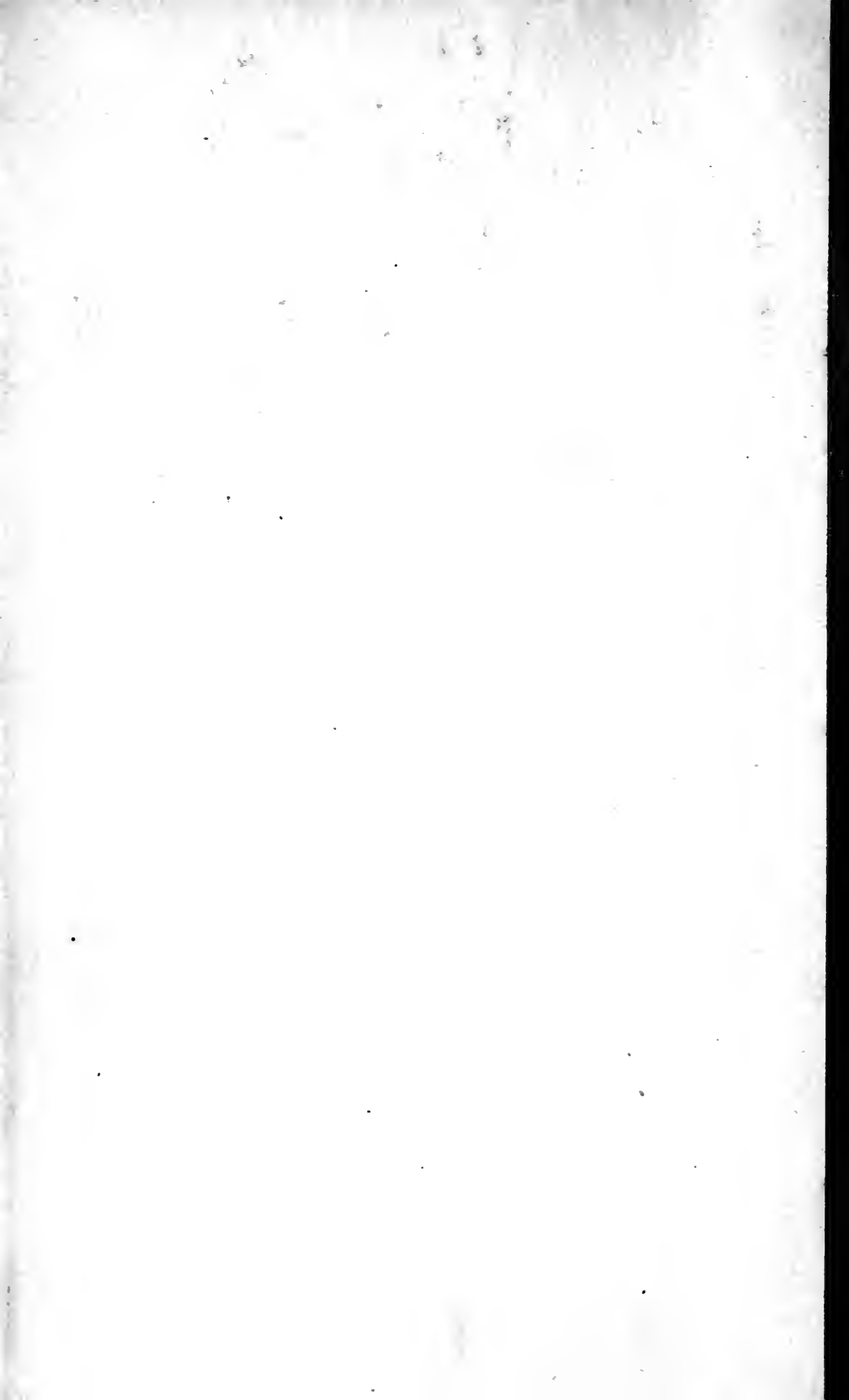

3 3433 07207479 6



ANNEX

Les
MCE

Digitized by the Internet Archive
in 2008 with funding from
Microsoft Corporation



A

MANUAL OF PHOTOGRAPHY.

Lead)
/AFE



A

MANUAL

OF

PHOTOGRAPHY:

INTENDED AS A

TEXT BOOK FOR BEGINNERS AND A BOOK OF REFERENCE
FOR ADVANCED PHOTOGRAPHERS.

BY

M. CAREY I.E.A.

SECOND EDITION,

REVISED AND ENLARGED.

PHILADELPHIA:
PRINTED FOR THE AUTHOR.
1871.



Entered according to Act of Congress, in the year 1871, by

M. CAREY LEA,

in the Office of the Librarian of Congress, at Washington. All rights reserved.

PREFACE TO THE SECOND EDITION.

IN preparing a second edition of this manual, rendered necessary by the early exhaustion of the first, the author has endeavored as far as possible to include all the information useful to the working Photographer. A very considerable portion of the matter in the first edition has been cancelled and rewritten, and over a hundred pages have been added, so that fully one-half of the book is new. The number of engravings has been also nearly doubled: all have been engraved expressly for this manual, and, with two or three exceptions only, all have been made from original drawings of the author.

The present edition also contains the results of several trains of investigation by the author, hitherto unpublished. Some of them he hopes will be found of material practical importance, especially those relative to "permanent" printing-paper and to water-proof negative varnishes. The arrangement adopted in the first edition has been continued in this. The first part gives a short and clear course of instruction for beginners. In the subsequent parts the various subjects are treated of in detail.

June, 1871.

THE UNIVERSITY OF CHICAGO
LIBRARY

1000 S. UNIVERSITY ST.
CHICAGO, ILL. 60607

TEL: 773-707-3000
FAX: 773-707-3000

CONTENTS.

PART I.

INTRODUCTION TO PHOTOGRAPHY.

	PAGE
CHAPTER I. Selection of Materials	9
II. Making the Negative	17
III. Printing	44
IV. General Rules for Beginners	47

PART II.

PHOTOGRAPHIC OPTICS AND THEORY OF PERSPECTIVE.

CHAPTER I. General Optics	52
II. Of Lenses	56
III. Faults incident to Spherical Lenses	58
IV. Focal Lengths of Lenses	66
V. Photographic Objectives	78
VI. Photographic Perspective	97

PART III.

PHOTOGRAPHIC MANIPULATIONS.

CHAPTER I. The Dark Room	107
II. The Glass Room	114
III. Pyroxyline and Collodion	126
IV. The Negative	147
V. Ambrotypes and Ferrotypes	188
VI. Portraiture	190
VII. Landscape and Architectural Photography	208

	PAGE
CHAP. VIII. Composition	234
IX. On Copying	251
X. The Stereoscope	256
XI. Microphotography and Microscopic Photography	258
XII. Development on Paper	260
XIII. Silver Printing	269
XIV. Failures in Photographic Operations	301
XV. Out-door Photography	344
XVI. Dry Plate Photography	351
XVII. Dry Processes	364
XVIII. Negative Varnishes	375
XIX. Treatment of Residues	379
XX. Photography on Glass and Enamel, and Collodio-Chloride Printing, &c.	383
XXI. Carbon Printing	398

PART IV.

THEORETICAL CONSIDERATIONS.

CHAPTER I. General Observations	404
II. Action of Light on Silver Compounds	406
III. Action of Various Portions of the Spectrum	413

PART V.

CHAPTER I. Photography in its Relations to Health	415
II. Chemical Manipulations	420
ADDENDA	431



MANUAL OF PHOTOGRAPHY.

PART I.

INTRODUCTION TO PHOTOGRAPHY.

CHAPTER I.

SELECTION OF MATERIALS.

§ 1.—Selection of Photographic Lenses.

THE information first wanted by the beginner will be as to his materials, and especially as to his lenses. They are to form the image which it will be his part to render permanent, and, unless they are right, his work will never be satisfactory. And they must not only be good in themselves, but expressly suited for the work which he proposes to do.

Such a thing as a universal lens does not exist. One combination is best for one purpose, another for another.

For *Landscapes* the best lenses are the View Lens, the Rapid Rectilinear, and the Steinheil Aplanatic. If architectural subjects, or any others, are introduced, in which straight lines must be preserved, the view lens will be unsuitable, because it slightly distorts, and although this distortion is of no consequence when buildings are not introduced, it will be a sufficient reason, when such are included, for using a lens of which the stop, or diaphragm, is *central*, that is, between two lenses, as in the case of the second and third of the above-mentioned objectives.

The view lens has also this fault, that it includes but a small angle of view, or, in other words, but a small portion of the scene at which it is exposed. This defect has been remedied in Dallmeyer's wide-angle view lens, of which the writer thinks very favorably; it is, however, not adapted for architectural subjects, for the reason already given.

The lens, whether single, double, or triple, is termed an *Objective*. The single lens has its stop in front, that is, on the object side, and the concave side of the lens must always be turned also towards the object. Sometimes, in cleaning the lens, it may happen that it is set back wrong side foremost, the effect of which is very injurious. In all cases when any lens is taken to pieces to clean, the utmost care must be used to replace everything exactly as before.

For *Portraits* there is but one lens proper, and that is the "portrait combination," invented by Petzval, and made by many excellent opticians in all parts of the world. For groups the Steinheil aplanatic is the best lens; it is often applied also for taking portraits, which may be obtained of large size with comparatively small lenses, at the expense, however, of rapidity of action. Triplets were formerly much used for groups, but are now superseded by the lens just named.

For copying engravings, plans, maps, &c., any lens with central stops may be used, except the portrait combination, which, as well as the view lens, is unsuited for such work. In copying, a stop with small opening will be proper.

A great mistake is often made by those who interest themselves in photography, in practising too much economy in their lenses. One lens cannot be made to do the work of another, except at a sacrifice of excellence of result. Every lens has a certain size of picture for which it is suited; if used for a smaller size, it will give a less angle of view, and work more slowly, than the lens made for that size; if strained to cover a larger plate than that which the maker intended, a sufficient sharpness of focus can only be got by using too small a stop. And the beginner cannot too soon learn what is too often overlooked, that, where solid bodies are to be depicted, a stop of a fair size is essential if the best effects are desired. It is only where flat objects, such as maps, engravings, or plans, &c., are to be copied, that small stops are right.

If the student intends at first to provide himself with one lens only, that had probably better be a Steinheil aplanatic. This and the Dallmeyer "rapid rectilinear" are the nearest approaches to a universal lens that we have.

IN COMMENCING photographic work, the student, whether he intends devoting himself chiefly to portraiture or to landscape

work, whether as amateur or professional photographer, will find it most convenient to begin by taking views, or, in other words, he will point his camera out of the windows and practise on whatever scene presents itself. He will endeavor in this way, firstly, to learn to make *clean work*, that is, to get negatives free from failures, such as stains, fog, comets, &c., and secondly, to secure *harmonious effects*. The first will be soon accomplished, but to obtain the latter in a good degree will require effort and experience. The high lights must be dense enough not to print through before the shadows are dark enough, and there must be *detail* everywhere. That is, the high lights must never show a flat white surface, but must be relieved by faint half tint, except, perhaps, in some very minute portion. The shadows must not show a black mass, but the shape and form of the objects in shadow must be everywhere perceptible.

Portraiture may next be attempted, and, in default of a sitter, a white plaster bust may be used, with different colored draperies. A white bust with black drapery makes a very difficult subject, and to obtain at once a well-shaded face and preserve the folds in the drapery, will be no easy task, but will afford excellent practice.

Care and cleanliness in the operations, and a thoughtful and close study of results, and comparison with their cause, will accomplish more in a month, than rapid, careless work in two or three.

In undertaking *landscape photography*, it is not well to begin with views too small or too large. The smaller the pictures are, the more easily they are taken in *every* respect; difficulty increases vastly with the dimensions. On the other hand, small prints are apt to be too trifling and insignificant to repay for the trouble expended upon them. Therefore the beginner will do well to start with "half size" plates, and go from that to whole size, after becoming perfectly familiar with all the manipulations. Eventually he will probably prefer to advance to 8×10 and perhaps larger work. Generally speaking, the most artistic effects are got with plates of from $6\frac{1}{2} \times 8\frac{1}{2}$ up to 12×14 . Larger prints are apt to be less pleasing, however technically perfect. It is no advantage whatever to have a lens embrace an unnecessarily wide angle, except, indeed, where architectural objects have to be

taken in positions where the photographer cannot recede beyond a certain point. An angle of 50° to 60° is generally best.

In undertaking *portraiture*, the beginner will naturally (after having just practised as above explained) commence with card portraits. For this work a "card lens" will be wanted, which is simply a small-size portrait lens. Of these, the French "Jamins" are the lowest in price; they are often very fair in their performances, though not equal to the best English, American, or German lenses.

Lenses should be kept with the greatest care—never wiped with anything except clean, soft old linen cambric, and even with this *only when necessary*. The exquisite polish on the surface is of the highest importance, and it is easily injured.

Do not begin by buying second-hand lenses, but go to responsible dealers and purchase the work of makers of reputation.

In choosing amongst a number of lenses by the same maker, view a piece of perfectly white paper through the lens, holding the latter close to it. If the appearance shows that the glass of which the lens is made has any color, especially if that color be brownish, the lens should be rejected: it may be expected to be slow. So, too, if, when carefully examined by reflected light, it shows any striæ, or hair-like lines. Very small bubbles, or white spots, if not exceeding one or two, are unimportant, and often occur in excellent lenses, though, of course, they are better absent, and, indeed, are rarely, if ever, found in lenses of the best makers.

These brief remarks are perhaps as much as the beginner can advantageously act upon. Other points will be explained later.

§ 2.—Selection of Camera.

Without a thoroughly good camera, no first-rate work can be done, and the beginner cannot make a greater mistake than that of purchasing a cheap one. Any camera that is not thoroughly good is absolutely worthless.

A camera is to be tested as follows:—

1. Observe if all the wood-work is sharply cut and closely fitted.
2. Try the rack and pinion movement, to notice that it works easily and regularly, and not by jerks.
3. Rack the back forwards until all the bellows body is closed

in; then continue to rack up till the back wood-work just comes into contact with the front. Observe attentively if this contact takes place everywhere at once—top, sides, and corners. If it does not, the camera is worthless, for the sensitive plate will in such a case not occupy a position perpendicular to the optical axis of the instrument.

4. These points having all been found satisfactory, it remains to ascertain whether the sensitive plate, when in place, occupies the exact position of the focussing screen of ground glass.

This is the most essential point of all, and is precisely that in which cameras, even of good makers, are apt to be defective. The fault, if it exists, is easily detected with a little attention.

Take a piece of plate glass of the size which the dark slide is intended to carry, set it in place, close the door, set the slide on the table, door undermost, and draw out the shutter. Lay across the middle of the slide a perfectly flat and rigid ruler, a draughtsman's straight edge, or a long, thick, narrow piece of plate glass. Take a piece of smooth hard card, rest one end of it on the plate-glass, pressing the side close up to the ruler, and with a sharp hard pencil draw a hair-line where the card touches the ruler. Next repeat this exactly with the focussing slide, ground side of the glass uppermost. If the camera is well made, the two hair-lines will exactly coincide to make but one. If they do not, the camera will require to be fitted over again by the maker. Care and attention are necessary to make this trial effectual, but it is essential to make it with every new camera.

An absolute coincidence of the two lines must be insisted on. At the same time, the experimenter must be sure that he is doing the measuring correctly, and not producing an apparent discordance by careless manipulation.

The next point requiring attention will be the *inside of the door of the slide*. This is always blackened in order that the light which passes through the sensitive plate during exposure may not be reflected back upon it, but this blacking is often very insufficiently done. It is not sufficient that the surface be perfectly black, it must also be *perfectly dead*, must have no appearance

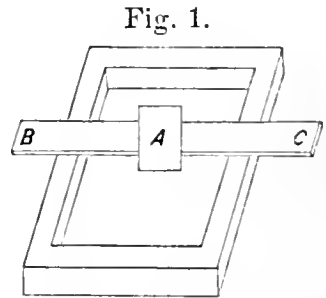

The bottom of the card *A* rests on the glass, the side rests against the ruler *BC*, and the pencil line is drawn where the edge *BC* touches the card *A*.

whatever of shining when held with the light falling upon it in any direction.

If any reflection is visible, and the maker be accessible, he should be required to render the surface perfectly dead. If the owner, however, finds it necessary to attend to this himself, he can mix

Powdered gum arabic	1	drachm.
Brown sugar	$\frac{1}{2}$	“
Fine lampblack	$2\frac{1}{2}$	drachms.

and rub them well together with a little hot water to a thick paste. This is to be applied with a flannel rag, and rubbed in well and evenly. But if the black appears to have been originally applied in the form of black varnish, it will be well to remove this polish in a great measure by rubbing with a rag moistened with a mixture of alcohol and ether. If the above mixture shines when dry, there was too little lampblack. If it soils the finger when rubbed, too much.

Carriers are small frames constructed to enable one with any given camera and slide to take a smaller plate than the proper plate of the camera; large cameras are often supplied with a set of these to enable the owner to take a whole series of sizes with the same instrument. They are certainly very convenient; they have the objection, however, that they sometimes yield a little to the pressure of the spring of the back of the slide, and allow the plate to advance too near the point, by a little distance, which may, however, displace the focus. Therefore the above system of testing should be repeated with each carrier. This method has the advantage that the plates receive the same pressure, and are under exactly the same conditions, as when receiving the image.

Of course, in testing, the plates set into the slides must be perfectly flat, or erroneous indications will inevitably result.

Although carriers will be often useful, yet, as far as practicable, it will be better to use the slide with the size of plate for which it was made.

Prevention of Stains.—Stains often occur from the absorption of more or less decomposed nitrate of silver from the slide, left there on occasions of previous use. Saturating the whole inside of the slide with some repellent substance has been found useful as a preventive. Paraffine or lard may be used. If paraffine be used it must be melted and the different parts of the slide plunged

in successively. Lard has the advantage that it may be rubbed in cold. Either the application should be made when the slide is new, or it should be well washed and all old stains scraped carefully away. If paraffine be used, each portion of the holder should remain in it about ten minutes, that it may be properly absorbed.

The Cut-off.—All slides should have a cut-off, a wooden spring inside the slit through which the shutter passes, and which closes the opening light tight when the shutter is withdrawn.

‡ 3.—Selection of Stand.

For out-door work, a folding tripod is employed. For in-door work many forms are in use. Those in which the table is supported by a single cylindrical stem are very objectionable, for want of steadiness. The most absolute steadiness is requisite, and a large proportion of the stands in the market fail to fulfil this requirement. A stand cannot be judged if almost unloaded. Place a heavy camera on it, strike it a gentle blow, and observe if any vibration follows.

‡ 4.—Selection of Chemicals.

Few photographers have sufficient chemical knowledge to be able to apply tests of purity to their chemicals. Perhaps the very best advice that can be given to a beginner is to observe who amongst his friends is most regularly and completely successful, and then to obtain materials from the same place. In fact, the demands of photography are now so enormous, that good materials can be obtained almost anywhere. The substance most likely to give trouble, in the hands of a learner, is nitrate of silver. This last should always be purchased prepared expressly for photography—never from the druggist. Without the best and purest neutral nitrate, the negative bath cannot be expected to work well.

The same remark is to be made respecting alcohol and ether, which are needed of the *very best* quality and higher grade than usually sold by even the best druggists. The photographer will need to have alcohol and ether always at hand to thin his collodion with; for, after coating a plate, the excess of collodion that is poured off (into a separate bottle) is always much thicker than

the stock in the bottle, and will probably need to be thinned as well as filtered before using again. This thinning work needs to be done chiefly with ether, sometimes with the addition of a little alcohol.

‡ 5.—Selection of Glass for Negatives.

Of all matters connected with photography, the selection of the glass is that which is most habitually overlooked.

Plate glass has some evident advantages over blown. Its surface is a true plane; the material of which it is made is generally whiter, and it is free from blebs and other faults and irregularities. On the other hand, it is found that the artificial surface of the plate glass, produced by polishing, does not hold the collodion and varnish so well after a lapse of years as the natural surface of the blown, and that with time the film is more apt to crack and suffer. The surface of plate glass is also more porous than the natural surface of blown glass, and holds back stains more strongly.

In consequence of the high price of plate glass in America, blown glass is almost exclusively used. But in this blown glass there is great variety of quality.

1. A good surface, free from knots and blebs, is important, and no glass that has not this characteristic should be employed. A smooth collodion film cannot be got on an irregular surface.

2. Glass varies greatly in *thickness*. It is a great advantage to have stout glass; the loss from breakage of negatives in the printing-frames is less, and the operator may venture to apply a strong pressure in his frames where his glass is strong: he thereby gets a sharper and cleaner print.

3. Blown glass varies extremely in *curvature*. Much of it is very flat; much, again, greatly curved. All that is much curved should be rejected. See also Part III., Chap. IV.



CHAPTER II.

MAKING THE NEGATIVE.

§ 1.—**Absolute Cleanliness.**

ALL photographic work depends upon the delicate turning of nicely-balanced affinities, which a slight alteration of the conditions may completely reverse. It is necessary, therefore, that the operator should not only follow closely the directions given, but that he should learn to constantly maintain a perfect cleanliness.

All the vessels which he uses must be irreproachably clean; and, as far as practicable, each should be restricted to some particular use, so that if slight vestiges of substances escape the attention, such may be less hurtful. The hands, especially, must be constantly washed; there is no way in which small portions of material are so readily transferred as by adhesion to the fingers. In all these respects too much precaution cannot be taken, and many failures, perfectly unaccountable to the beginner, may be traced to trifling neglects of this sort. Nothing will so well repay its trouble as a systematic and invariable attention to having the hands and all the utensils clean beyond suspicion.

§ 2.—**Preparing the Glass.**

Unless the glass be *perfectly* clean, a regular development cannot be hoped for. Perhaps the best method of cleaning glass is one introduced into photography by the writer a few years ago, and which has since been extensively used.

Provide a large glass pan, in which make a mixture in the following proportions:—

Bichromate of potash	2 ounces.
Sulphuric acid	3 fluidounces.
Water	25 fluidounces.

Place the pieces of glass in the pan alternately, one at each end, so that their ends shall overlap a little, and allow the free passage of fluid between them. For new glass half a day will be

sufficient to destroy the greasiness. Old glass that has been used before, should have a day, and, if it has been varnished, even longer, or a mixture containing only half the above proportion of water.

So long as this bath is yellowish-brown, it is active. When it acquires a violet color, *it is spent*, and will want renewing.

After a suitable immersion in the cleaning bath, place the glasses one by one in a pan under a water-faucet, and, as fast as the water fills the pan, lift one end, and empty it. Repeat this half a dozen times at least. Then take up the first plate, *let the stream of water run some seconds, first on one side, then on the other*, until every possible trace of the cleaning bath is removed, and then rub dry with soft blotting-paper—not with cotton rags, as so universally directed. Cloths always leave fluff, which has to be carefully brushed away afterwards—paper does not.

It is usual to roughen the edges of the plates, and thus diminish the chances of having the film slip off during the work, and also to lessen the risk of cutting the fingers. A coarse file is commonly used, but the writer greatly prefers a coarse whetstone, such as is used for sharpening scythes. It cuts faster and more evenly, doing better work in less time, and is good until wholly worn away, whereas the file quickly becomes clogged and smooth. The whetstone, or file, is to be drawn three or four times along each edge, holding it so that it shall rest more on the face than on the edge. The roughing should precede the cleaning. After cleaning the glass must be handled as little as possible; its face must *never* be touched by a finger, or there will probably be a finger mark developed on the negative. Glass when cleaned should be laid away, each piece in a fold of soft clean blotting-paper, in which it may lie even for months without injury, if set in a box kept out of the reach of dust and vapors. The writer has used glass which, after cleaning with the bichromate bath, had been kept *eighteen months*; it gave good results. When glass is to be kept for more than a few days, it should rest on its edges, and not lie flat, otherwise there is a *possibility* (the writer has seen this happen) that folds in the paper between two sheets, may show in the development.

Nitric acid may be used for cleaning, or caustic alkali; but the above is not only the easiest and most economical, but is perhaps the only one with which an old picture never reappears in the development of a new one.

Plates that have been *varnished* are necessarily more difficult to clean. They will need a stronger bath and a longer immersion in it. Or the varnish may be easily and completely removed by soaking in a bath of caustic soda. It is best to wait till a quantity accumulate, and then to dissolve a pound of "concentrated lye" in a half pailful of hot water, and put the plates in, one by one, leaving them in till they easily rub clean; after rinsing off, put them into the bichromate bath for a few hours. When common photographic glass is used, varnished plates scarcely repay for the trouble of cleaning, especially as, if the cleaning is not done carefully, the negatives will not be satisfactory.

§ 3.—The Negative Bath.

Of all that the photographer works with, nothing exceeds in importance the negative bath. Its preparation is exceedingly easy, and, if thoroughly good nitrate of silver be used, it cannot fail to work well, if no mistake or oversight has been made in its preparation.

A *vertical glass bath* is to be procured; there is none other which is perfectly safe. In a porcelain bath, if there is the slightest flaw in the glazing inside, the solution will penetrate it, and gradually saturate the whole of the porous biscuit which makes the body of the vessel, between the inside and outside glazing. This not only involves a great loss of expensive silver solution, but after a time the outside glazing also probably cracks, and some day the operator finds his bath empty. In many cases porcelain baths last for years, but there is never a certainty about them, as there is with glass. The "photographic ware" has been much complained of in the same way.

A glass bath requires to be supported in some way, and the simplest is to place it in a box sufficiently wide to give the bath a proper inclination, laying a wooden or pasteboard cover over it, when not in use, to exclude the dust; or boxes may be purchased provided with covers, and with an iron foot at the back to enable the box to stand at a proper inclination (see beyond, Fig. 6, p. 24).

A "whole-size" bath, for plates $6\frac{1}{2} \times 8\frac{1}{2}$, will be found a convenient one for the beginner, as, even if much smaller plates are worked with, it is not worth while to use a smaller bath—it holds too little solution and changes too rapidly. The "whole-size"

baths require about 25 ounces of solution to charge them. This solution is to be made as follows:—

Dissolve 2 ounces of nitrate of silver in 25 ounces of water, which need not be distilled water. Leave the solution in a glass bottle in the sunlight for several hours, or in cloudy weather for a day or two near a southerly window. Separate this into two equal portions. Take 3 grains of iodide of potassium or iodide of ammonium, dissolve it in a few drops of water, and pour it into one of the halves; stir up well and let stand half an hour, or longer. Filter the *other half* into a clean bottle, and then filter into it the second half, that to which the iodide of potassium was added.

Observe: The two portions are not to be mixed until *after* they are filtered, and the portion to which the iodide was added is to be filtered *last*, if the same filter be used for both.

Next, take a clean six-ounce stoppered vial; place in it one fluidrachm¹ of pure nitric acid, fill it up with water, and label it "Dilute nitric acid, ten minims to the ounce." To the twenty-five ounce bath add one fluidrachm of this dilute acid.

If this does not prevent fogging, the fault is probably in the collodion. It will therefore be advisable to add to it enough tincture of iodine to bring it up to a light sherry wine color. Tincture of iodine (which must not be confounded with "Lugol's Solution") may be purchased ready made, or be prepared by dissolving a quarter of an ounce of iodine in four ounces of alcohol; it should be prepared and kept on hand, as it does better after standing for a time. If with a collodion of a sherry wine color, and the acidification already mentioned, which is in the proportion of about a drop of nitric acid to twenty ounces of bath, the fogging continues, it shows that there is something very much wrong. The operator may try the effect of a further addition of acid, but he may be assured that either he has made some mistake, or is working with bad materials. More acid may force a clean picture, but will fail to give delicately graded shadows and half tints. (See also Chapter on Failures.)

The negative bath should always be kept covered to exclude dust and dirt. Constant care must be taken to let no extraneous

¹ The photographer should provide himself with graduated measures of one pint, of two ounces, and a minim glass for measuring a drachm and its fractions. Oneminim of water weighs one grain nearly, and corresponds approximately with a drop. Sixty minims make the fluidrachm.

matter get into it, and to place it in nothing, and nothing in it, that is not *perfectly* clean.

When the bath by use will no longer work well, add bicarbonate of soda till the bath just turns red litmus paper blue, boil it down to one-half, expose it for a day to sunshine, filter, dilute, and add just enough dilute nitric acid to get a clean picture, with a collodion known beforehand to give good results. Of course nitrate of silver must be added from time to time to keep up the strength, which is rapidly diminished by sensitizing plates.

Litmus Paper is useful to indicate whether solutions are acid, alkaline, or neutral. An *acid* solution turns *blue* litmus *red*; an *alkaline* turns *red* litmus *blue*; a *neutral* solution is without influence on either. The paper should be cut into narrow strips, and kept in a wide-mouthed vial, corked.

§ 4.—The Developer.

Make the developer as follows:—

Proto-sulphate of iron	400	grains.
Acetic acid, No. 8	1½	ounce.
Alcohol	1½	“
Water	20	“

The developer, if kept corked, will keep for a couple of months. It is ready for use as soon as the solution of the sulphate of iron is complete and the whole has been filtered. As it grows older it becomes reddish, but, so long as kept clear by filtration, the reddening is rather beneficial than otherwise.

§ 5.—Collodionizing the Plate.

Holding the clean glass plate by pressing a finger or two of each hand at the *edges* of the plate (the fingers must *never* touch the face), hold it up to the light, and look along the long edge to see which is the convex and which the concave side. The choice between these is a matter involving a variety of considerations which will be stated in full farther on. The beginner will find it best to generalize as follows: for portraits and for buildings, coat the hollow or concave side; for landscapes, the convex side. Next brush it off with a broad (two-inch) soft camel's hair brush, which must be kept clean and free from dust, and be used for no other purpose. It should not even be left in damp air, or it may

leave streaks of dampness on the plate, producing stains in development. It is an excellent plan to have a tin box, three or four inches deep and an inch larger in breadth and length than the plates which thus lie in it between folds of *clean* blotting-paper. Any impurity in the paper is transferred infallibly to the glass. The writer has seen glasses between which newspapers had been laid, take off a complete copy of the print. If the glasses remain for a long time unused, the box should be turned on its edge that the plates may not rest on each other. The brush should lie in this box, ready for use. When the brush is drawn over the surface of the glass, it should slip over with a peculiar facility. The careful operator will occasionally notice an absence of this facility: the difference is so slight that only experience enables one to appreciate it, but when once observed it is unmistakable. This always indicates that the plate, though it may have been well cleaned, has not been sufficiently rubbed in dry-

Fig. 2.

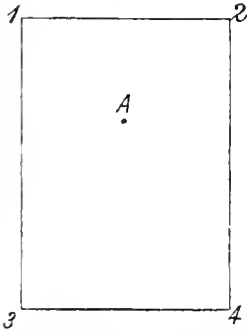

Hold at 3, pour on at A, or even a little below the dot, and off at 4.

Fig. 3.

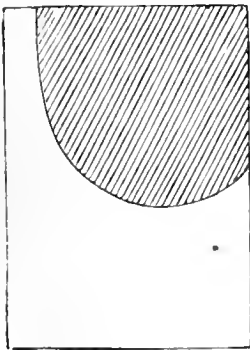

ing. A quick rubbing with clean dry blotting-paper will at once remove this, and enable the brush to pass easily and lightly over the surface. But rubbing just before coating is always objectionable: the glass becomes electrical, and attracts and holds motes of dust that may be floating through the air.

After brushing, gently but thoroughly, take the plate in the left hand, three fingers supporting it underneath, the thumb pressing on the corner, and the narrow end towards you. Fold up a piece of blotting-paper, and put it between the bottom of the plate and the finger ends. For want of this there will occasionally appear curious mottled markings at the points where the fingers touch the under side.

Take the collodion bottle in the right hand, having previously removed the cork and wiped the lip to remove dust or fragments of dried collodion. (*Never* neglect this, and repeat it between every plate.)

Pour the collodion slowly and steadily on, letting it come upon the plate at a spot a little further from you than the middle—say equi-distant from the end and the two

sides (see A, Fig. 2). Pour on till the pool covers rather less than half the plate.

Incline the plate till the pool extends itself to corner No. 2 (see also Fig. 3), then to corner No. 1 (see Fig. 4). Then bring it down to the lower end, reaching, however, corner No. 3, where the thumb is, before corner No. 4, at which it is to be poured off (see Fig. 5).

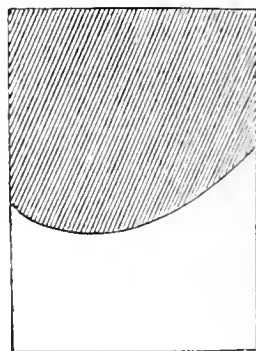

Fig. 4.

This is all to be done quite coolly, and yet without loss of time. The collodion must go up *full* to the edge of the plate all round, and with a little practice this is accomplished with great ease and without spilling a drop. When the operator has learned to do this with ease, he will find it a good plan to *send back* the collodion from 4 to 1 before pouring off, by raising corner 4; as soon as the wave reaches 1, corner 4 is lowered again, and the excess poured off there. This makes a more even plate.

Fig. 5.



It is best not to pour back the collodion into the bottle from which it came, but have a separate bottle ready, uncorked.

The operation of pouring off requires the operator's best attention. The plate must be slanted but very little, otherwise the collodion runs off too fast, and leaves too thin a film, especially at corner No. 1. At the same time the operator *rocks the plate*, that is, turns it backwards and forwards, one quarter round,

without changing the inclination (see Fig. 5, in which the dotted line shows the direction taken by the upper left-hand corner). If this be neglected, the film will be full of *crapy lines*. If the plate be properly rocked, it will dry as smooth as the glass itself.

The writer has endeavored here to give as clear a description of the method of collodionizing a plate as possible; at the same time it is unquestionably one of those manipulations which it is almost necessary to see done, in order to execute properly one's self.

No formula for making collodion is given here. The beginner is strenuously advised to introduce no unnecessary difficulty by such attempts, but to procure a reliable collodion from some professional photographer or trustworthy dealer. When he has mastered the manipulations, he may advantageously make his own collodion, for which a number of good formulas will be given further on. The nitrate bath, the developer, and the fixing solution, on the other hand, every one must learn to prepare for himself from the outset.

§ 6.—Sensitizing.

The collodion coating quickly sets—in half a minute or less in summer, whilst a minute may be necessary in winter. The beginner may judge of its condition by gently touching it near corner No. 4 with the tip of the finger; if the film does not wet

Fig. 6.

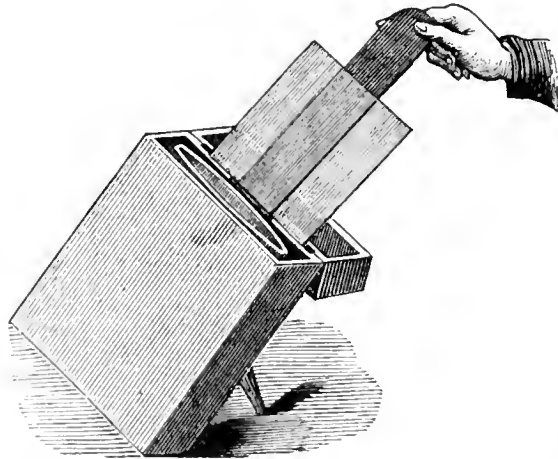

the finger, but receives a slight depression from it, which remains after the finger is removed, it is called "tacky," and is now ready for immersion in the bath. Up to this time the rocking motion is to be steadily continued, pausing only for a second, if

necessary, to ascertain the condition of the film. When this has attained the proper state of setting, the plate is to be rested upon the dipper firmly and steadily. The operator next lowers the dipper, carrying the plate with it, into the bath, by a gentle, continuous, and uninterrupted motion. For if he pauses for any fraction of time, however short, the part of the film which at that moment corresponded with the surface of the bath will show a distinct line, ruining the negative. No unnecessary delay should occur in putting the plate in the bath, or the risk of marbled stains is increased.

Dippers are made of porcelain, glass, and gutta-percha. If glass ones could be got of a right pattern, they would be preferable, but made of rods they are too fragile. The porcelain are good, and the gutta-percha also, provided they are well made, and consist wholly of gutta-percha, without any metallic support in the centre. The porcelain dipper may rest in the bath when not in use; the gutta-percha dipper must never be left in the bath. The porcelain is the best and safest. It has, moreover, this recommendation, that if the plate slips off, and goes down to the bottom of the bath, the porcelain dipper can be easily worked under it; at least this can be done with glass baths, the bottoms of which are always a little rounded and hollow.

If the plate whitens too rapidly in the bath, it is an indication that it has waited too long between coating and immersing, has become too dry, and its sensitiveness will be impaired. The plate should wait only long enough to prevent splitting in the bath, or turning mottled in the part least dry, both of which results are liable to follow too quick an immersion. This mottling must, however, not be confounded with the mottling at the pouring-off corner, which results from a collodion too thick, or containing too large a proportion of alcohol, or alcohol not up to 95 per cent.

It has just been said that the collodion poured off from the plate must be received into a different bottle. This is because it is apt to carry with it motes and particles of dust, which appear on the next plates. The collodion is, however, perfectly good for subsequent use, but it will not only need to be filtered, but *thinned*, because the evaporation which takes place from the moment that the collodion is on the plate, causes the portions poured off to be much thicker than the original stock. As the *ether* evaporates more rapidly than the alcohol, the thinning is

best done altogether with ether. Neglect to thin the collodion will produce ridgy plates, and especially in hot weather, tend to the production of small transparent spots, known as pin-holes, appearing anywhere on the plate, but oftenest in the dense parts, particularly in skies of landscapes.

(The sources of trouble in photographic operations have been collected together by the author, and will be found in a "Chapter on Failures," farther on, in which they have been classified for easy reference by the photographer whenever occasion may call for it.)

The plate having been placed in the bath will be left quiet for a couple of minutes, and then must be moved up and down from time to time; and a side motion is also beneficial, especially if the plates show a tendency to form lines in the direction of the dip, a trouble of which much complaint has been made by some photographers, though it has never been experienced by the writer. Until the plate has been in some minutes it should not be raised in moving so as to be partly uncovered by the silver solution.

The *time* requisite for stay in the bath cannot be fixed in minutes with any positiveness, as it depends somewhat on the temperature, the nature of the collodion, and the condition of the bath. From three to five minutes is about the time. The plate is ready when, on withdrawing from the bath, no oily lines form on the surface, but the whole face presents a uniform moist film. The plate should never be left longer than necessary in the bath, as by so doing the film tends to dissolve, thus choking the bath with excess of iodide, and rendering the plate irregular. Worse still, there is a great tendency in such plates to give flat and dull images, at least in collodion containing bromides.

There is, of course, always a little latitude allowable. And it is to be remarked that a plate removed from the bath as soon as the oily streaks are gone is in condition to give the *cleanest* plates; if left a little longer, it gains in sensitiveness, but also there is a little more tendency to veil.

The plate is now to be removed from the bath and rested on several thicknesses of soft blotting-paper, changing its position every few seconds, until it no longer wets the paper. A thorough draining in this way is very important, and cannot be neglected without danger of streaks and other irregular action. At the same time the back of the plate is to be carefully wiped dry with

soft paper. This wiping and thorough draining must never be omitted; neglect of these precautions will tend to produce streaks and stains. It is a very good plan to keep ready pieces of thick soft red blotting-paper, half an inch smaller than the plate all round; and after it has been wiped clean to apply one of these pieces moistened with clean water, but not too wet, to the back. This precaution, though recommendable, has not yet come into general employment. Its use is to diminish internal reflections or *blurring*, as will be more fully explained hereafter.

In all these operations the face of the plate must never be touched by the fingers, and with the same precaution the plate is to be lifted and gently set into its place in the dark side, taking care that the shutter is in its place. The door is then closed.

From the time that the plate is lifted from the bath the same edge must carefully be kept undermost; that is, the side which went undermost into the bath must be kept undermost—must be that which rests on the blotting-paper—must be kept undermost in the transfer to the dark slide, and the slide with its plate in it must be carefully kept with that edge downwards, not only during exposure, but in carrying backwards and forwards and up to the moment of development. This *is essential*; neglect of it will almost certainly result in streaky lines and irregular deposits along the outside of the plate, running up in places some distance into the plate. If the small size of the bath renders it necessary to set the plate in *end* down, when the *side* is to be down in the slide, the plate must be turned *immediately* on taking it from the bath, and the draining and blotting done whilst it is in the same position which it is to have in the slide. In this way no harm results from the change of position.

Particular descriptions of the dark room and glass room must be omitted for the present. Here it is sufficient to say that all the operations of sensitizing and developing must be performed by yellow light. A very simple way of converting an ordinary room into a dark room for photographic work consists in procuring some of the very thickest and stoutest brown paper made for envelopes, and pasting pieces of it over the panes of the window; a great deal of light will come through this, sufficient for all the operations, and yet, if the paper be good and thick and of fine grain and quality, there will be no danger of fogging. If, however, the sun shines directly, at times of the day, upon the window, it will be well to have a buff curtain on rollers inside the

window, so that when the light is too strong it may be properly tempered.

If the room used as a dark room has two windows, it will be found preferable to cover the panes of one only, and to have closely fitting inside shutters to the other, over the joints of which black muslin must be pasted or tacked. In this way the room may be lighted at any moment, and may serve for other uses than merely as a dark room.

However the dark room be arranged, *provision must be made for its thorough ventilation*, the fumes of collodion tending to produce headache, nervous exhaustion, and to undermine the health. This subject will be recurred to hereafter; it should never be lost sight of by the photographer who values his health.

§ 7.—Focussing.

The photographer first covers the camera with a black cloth, and places his head beneath it. The cloth should be ample to exclude all white light; even a few scattered rays of light will greatly diminish the brilliancy of the image as seen on the ground glass, and interfere with a proper judgment. The picture should be composed and arranged with the largest opening of the lens, and after this is done the proper stop is next substituted and the focus carefully taken.

Few persons have unassisted sight so sharp as to enable them to take a thoroughly good focus, although a delusion to the contrary is very wide-spread. It is always better to examine the image on the ground glass through a microscope, as a better focus can be got more quickly, and with less strain upon the eyes. The microscope should consist of two lenses in the same tube, at *least* an inch in diameter. The difference of fatigue to the eyes in using large and small lenses is enormous. A magnifier, with lenses of one and a half to two inches in diameter is the best; its expense is small, as it is not absolutely necessary that the lenses should be achromatized. The little doublets used by engravers are good, and larger ones can be got of any optician of the same pattern. The writer does not advise the system of focussing on clear glass with an adjusted eye-piece.

The operator is not to take his focus on any point of the picture indifferently, but according to the following rules:—

In taking a single portrait, focus on the face as the most important point.

In taking two heads equidistant from the centre, focus on either head, not on any more central object.

In taking a group, focus on one of the heads occupying a position midway between the centre and the extremity of the group.

In focussing a landscape, care must be taken that the foreground is in good focus, and at the same time that sufficient sharpness is preserved all over the picture. The largest stop with which this result can be obtained, must always be used. It is, however, not necessary that very distant objects should be as sharp and clean cut as the foreground must be; to accomplish this would require the use of a stop so small as to flatten the whole picture. Many, however, do this, and the result is that their pictures have no effect of distance or atmospheric perspective. On the other hand, if the focus be not taken with judgment, the result will be a failure. A *swing back* (hereafter to be described) aids materially in getting a whole view into good focus with a large stop.

These directions are important, and cannot be disregarded with impunity. Careless focussing is almost the worst fault that a photographer can have, and will counteract every care or precaution that he can take in other parts of the process.

Where buildings of any description form part of the subject, it will be necessary to *level the camera*, otherwise the perpendicular lines of the edifices will not be perpendicular in the negative, but will converge or diverge. This levelling the camera often prevents the upper part of the building from appearing upon the ground glass. Material help can be gained by *raising the sliding front* (see Fig. 7). This, however, must be done with circumspection, or the upper corners of the negative will be transparent (and print black) by being outside the circle of light given by the lens. It must be also remembered that the definition is always best at the centre, that when the lens is shifted in position by raising the front, the upper parts of the objects will not be quite so sharp as when the lens is in its usual place; nevertheless, the

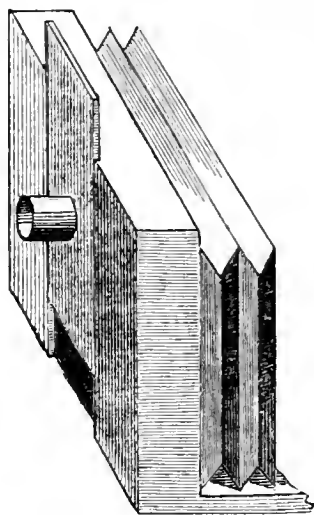

Fig. 7.

plan is a useful one. The *swing-back* is also useful, but will need an intimate acquaintance with photography to avail one's self of it; its operation will be explained hereafter.

§ 8.—Exposure.

The time of exposure for a wet plate may vary from a fraction of a second to half an hour.

With a portrait combination, medium stop, and good light from three to fifteen seconds, or even more, may be required. With landscapes taken by a view or a doublet lens and medium stop, from ten seconds up to several minutes may be given, according to the light. With a bright light, and by having the chemicals in exact order, a picture may be got in a fraction of a second with a short focus lens, using a large stop. The operator, however, will do well to leave instantaneous photography until he succeeds regularly and without difficulty in ordinary exposures.

The slide should always be set into the camera steadily and gently, not with a jerk or snap, lest any dust be set in motion and settle on the sensitized plate, the result of which will be seen in *comets* or *pin-holes*.

§ 9.—Development and Redevelopment.

The operator brings back the dark slide, without loss of time, to the dark room, never forgetting for an instant to keep that part of the slide down which was lowest in the camera, and in all previous stages. Holding the slide with the left-hand edge in his left hand, he opens the door with his right, places his thumb on the upper edge of the plate, with the fingers touching it lower down, and, by inclining the slide a little backwards, brings out the plate. This is now transferred to the left hand, always keeping the lower edge downwards. He now turns the plate up nearly to a horizontal position; a proper quantity of the developer (about an ounce for a whole-sized plate, or, for a beginner, a little more) has previously been placed in a suitable glass vessel—Fig. 8 represents a good shape; this the operator takes in his right hand, and holding it a little inclined, and at the upper edge of the plate near the left hand, pours out the liquid, at the same time drawing the vessel towards the right, so that the liquid may

spread rapidly and evenly over the whole surface of the plate. Some dexterity is required to do this, except with very small plates. Just as the developer spreads over the plate and reaches the lower edge, the plate is carried to a horizontal position, for it is an object not to let more than can be helped run over. The developer becomes mixed on the surface of the plate with the bath solution with which the film is impregnated, and this mixture provokes the development. If much is wasted by washing over the side, the image will come out less strong, and a redevelopment will be more likely to be necessary.

Fig. 8.

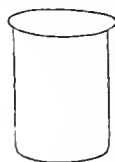

The rapidity of development under the action of the developer will depend on what has been the exposure. If the image flashes out instantly, the exposure has been too long, and the picture will want contrast. If the picture comes out slowly, reluctantly, so that after a minute or two only the strongest marked points of the subject are visible, the exposure has been too short, and the picture will probably be too full of contrast, wanting in detail, and hard and blocky. If the picture soon begins to show itself, and, instead of flashing out too suddenly, grows steadily and even rapidly in strength, a good result may be anticipated. As the development goes on, the operator inclines the plate a little in different directions, so as to render the developer regular and even in its action. When the plate has come pretty well out the operator pours off the developer from one corner into its vessel again, and, as he drains the last drop, he raises the plate perpendicularly between himself and the light, and judges of its strength and character. If these appear satisfactory, he stops the operation by washing off the plate; if not, he pours on the developer again (provided this last has remained active and clear), and keeps it on a few moments longer. But if it seems to have ceased its effects, and still more, if the slightest tendency to fog manifests itself, or if the developer looks in the least muddy, the operator quickly washes the plate, and if on a further careful inspection he finds that it still wants strength, he proceeds to redevelop.

Care will always be needed that the developer is used in sufficient quantity to cover the plate quickly and easily. Too much is always better than too little, though with too much developer the silver will always be too much diluted and washed away, and

there will be more probability of a redevelopment being needed. (Very full information in all the details of development will be found in the second part.)

Another point will require special attention. The developer is apt not to mix easily with the bath solution contained in the film; as long as the plate is level the tendency does not appear. But when the plate is raised to judge of its strength by looking through, and part of the surface liquid drains off, the indisposition to mix shows itself by the formation of *oily lines* resembling those upon a plate removed too soon from the negative bath. Now these oily lines that form on the plate when raised to look through, consist of the developing liquid which collects in that form, consequently the development of the plate goes on under these lines, and checks elsewhere. There results a set of streaks on the plate that wholly ruin it. There is no more fruitful origin of trouble to beginners than this, and its source is often wholly unsuspected. Nor is it easily avoided. If the negative bath have been a good deal used, the addition of alcohol to the developer to the proportion of an ounce or two to the pint will sometimes help.

Redevelopment may be done either before or after fixing, the difference is but slight in the final result; as far as it goes, it may be stated as follows: If the contrasts are likely to be a little too great, or tend that way, redevelop before fixing; if the contrasts are scarcely sufficient, fix first and redevelop afterwards. Not much, however, in the way of a curative agency can be expected in this way, and pictures which are either too harsh or too uniform, are best wiped out at once and taken over.

The operator will always bear in mind, in deciding when his development or redevelopment is carried far enough, that the apparent strength of the picture, as he then sees it, will be considerably reduced in the operation of fixing, and for this he must make due allowance.

A close watch must be kept on the plate, and if the slightest tendency to form oily lines shows itself, the plate must be *instantly* held under the tap, or better, be plunged into a pan of clean water ready for the purpose. And if it proves on careful examination to want density, this must be got by redevelopment.

Negatives that come out of the right strength by the first development are the best. If under-exposed, they are apt to become

hard and crude in the process of redevelopment; and if over-exposed, the evil is incurable. A brilliant print can only be got from a brilliant negative. Much will depend upon the collodion, or, rather, the pyroxyline from which it is made. Highly sensitive collodions, and those newly prepared, are more likely to need redevelopment: more intense pyroxylines and older collodion less likely.

Redevelopment may be effected in various ways. The most usual is with pyrogallic acid, and that is the plan which I shall here describe.

To redevelop with pyrogallic acid, the operator keeps in a stoppered vial the following solution:—

Nitrate of silver	60 grains.
Citric acid	120 “
Water	6 ounces.

And in a well-corked vial:—

Pyrogallic acid	$\frac{1}{2}$ ounce
Alcohol	4 ounces.

Both these solutions will need filtering; both keep for months.

When the iron development has done what it can, and before any disposition to fog sets in, the plate is to be thoroughly well washed off. In a convenient developing vessel the operator puts water, about an ounce or a little less for a $6\frac{1}{2} \times 8\frac{1}{2}$ plate, and proportionately for other sizes. He next adds a little pyrogallic solution, about twelve or fifteen drops for the ounce of water, with which it immediately mixes. He then adds a few drops, say fifteen or twenty, of the silver and citric acid solution to the ounce of water, mixes well, and pours the mixture over the plate. The image immediately begins to grow in strength, and, by keeping the silver and pyro on, any desired degree of strength can be obtained. The redeveloper soon darkens to a wine color, and in that condition its action is still powerful. But if it becomes in the least muddy, it must be rapidly washed off the plate. So long as the solution remains transparent and bright, even if port-wine color, it is not easy to fog the picture. Still, even the pyrogallic developer is not to be trusted too far, or fog may set in in brown spots. When redeveloping is done after fixing, the hyposulphite must first be washed off most thoroughly, *back* as well as front.

When it is intended to redevelop plates that have been fixed and dried, a little more care is necessary. It is best to redevelop in a pan. And as there is here more danger of spotting and staining, it is best to add a little acetic acid besides the citric. The operator watches the operation, keeps the developing bath continually moving by tilting the pan, and examines the progress of the work at intervals. Plates after drying take density more slowly than when redeveloped immediately after the first development. When plates have been allowed to dry, and are afterwards found to need redeveloping with pyro, they are apt to show a tendency to split in drying after the redevelopment; it is therefore a good plan to flow them over with the following solution:—

Clean gum arabic	2 ounces.
Water	20 “
Carbolic acid	$\frac{1}{2}$ drachm.

The carbolic acid enables the gum solution to be kept indefinitely without moulding or souring. A little of the solution is poured over the plate, worked in by moving the plate so that it shall spread over the whole surface, which can easily be judged of by catching the light upon it. This is drained off by holding up the plate, and the operation repeated with a fresh portion of solution, after which the plate is reared up to dry. Different collodions vary very much as to tendency to split in drying, and to their need for this protection. (This operation does not take the place of varnishing; plates that have been gummed must be varnished the same as others.)

A pyrogallic development may be used in the first place instead of the iron. In this case the pyrogallic acid solution is added to water, about eight drops to the ounce, a little acetic acid is added, and the mixture is poured over the plate as it leaves the frame. This is a very easy development, and gives bright, strong pictures. But the iron development is preferable, because softer pictures are got, more full of detail, and shorter exposures are sufficient.

The vessels used for developing must be kept scrupulously clean. If the remains of the developer be left in them a few minutes, it becomes turbid, and a gray-black precipitate of metallic silver collects round the sides and bottom. Any of this left in will tend to render the next lot of developer muddy, and therefore must be completely removed.

I am in the habit of keeping beside me the following solution in a beaker or wide-mouthed bottle:—

Concent. solution bichromate of potash	. . .	1 fluidounce.
Sulphuric, or better, hydrochloric acid	. . .	$\frac{1}{2}$ “
Water	3 fluidounces.

It is only necessary to pour this solution into the dirtiest developing vessel, and then immediately out again, when it will be found perfectly bright and clean. It is scarcely necessary to say that it must be well rinsed.

The same solution is very useful for removing silver stains from the fingers. If got into cuts or abrasions of the skin, it is to some violently irritating, to others quite indifferent, except a momentary smarting. It is much preferable to the use of cyanide of potassium, a most dangerous chemical, and the indiscreet use of which is injurious to health, and may become destructive to life. Or they may be rubbed with strong tincture of iodine (alcohol 1 oz., iodine 40 grs.); and when the stain has become yellow (not before), it will dissolve in a strong solution of hyposulphite of soda.

Of these methods, the first will generally prove the most efficacious; it should be followed by washing with hyposulphite. All silver stains, however, should be attacked before they are *set* by exposure to light, otherwise the difficulty of getting rid of them is greatly increased.

§ 10.—Fixing, Washing, and Drying.

The negative fixing-bath consists of a strong solution of hyposulphite of soda, in the proportion of five or six ounces to the pint of water. Some pour the solution over the plate until it is clear. But this involves a loss of time. It is better to keep the fixing-bath in a horizontal pan, and carefully to slide the negative into it. When the yellow opaque appearance of the iodide and bromide has completely disappeared, the plate is fixed. The same bath may be used for a number of negatives, but should not be kept too long. A yellowish *feathery appearance* through the film indicates insufficient fixing, and may be removed by another immersion in the fixing-bath.

The plate thus fixed is to be set under a tap and thoroughly washed by allowing a stream of water to fall upon it, whilst the

plate is supported at such an angle that the ripple is seen to spread in all directions, and keep the water in continual motion over the whole surface of the plate. To accomplish this, the plate must be kept in such a position that the stream of water

Fig. 9.

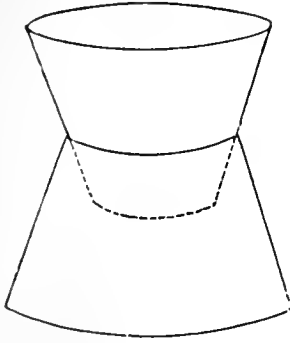

which falls upon it will flow off in every direction. The writer finds the most convenient mode of accomplishing this to consist in having two cones of zinc, as represented in the margin. The lower and larger is six inches in diameter at bottom, and five at top; stands seven inches high. The upper is six inches diameter at top, three at bottom, and five inches high. Both are open at top and bottom, and small notches are cut at the base

of the larger. The negative rests on the upper rim; it will be found easy to give it any slant in any direction, and with the advantage that it will retain that position with entire steadiness. After setting the plate upon this or any other support during the washing, the operator must never fail to catch a reflection of light upon the surface of the plate to assure himself positively that the water is in motion all over the surface, otherwise the washing will not be well done. The above dimensions will answer for all sizes of plates up to 8×10 and even 10×12 .

Ten to fifteen minutes is the right time for washing a negative, although much less is often given by hasty operators. It is almost as important to wash the *back* as the face, although the latter requires only simple rinsing off. If this be neglected, portions of the hyposulphite bath will remain there, and, when the plate is set up to dry, will run down to the edge, and thence be drawn up by capillary attraction into the film, preparing the way for spots and stains at some future time.

The plates are next allowed to dry, either reared up cornerwise in a drying-frame, or simply supported in a vertical position, resting on several thicknesses of blotting-paper. Fig. 10 represents a very convenient rack made by simply attaching upright pieces to a flat board. Racks can be purchased of the dealers to hold a much larger number of negatives; the form in the figure is, however, very convenient, and safer.

From the time that the plate enters the fixing-bath the plate may be exposed to the light without injury.

If it is intended to redevelop the plate after instead of before

Fig. 10.

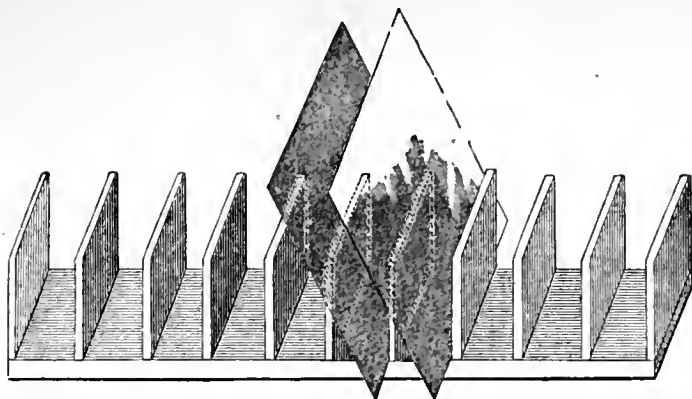

fixing, the washing must be equally careful after the fixing solution is applied, or the application of the redeveloping solution will cause brown stains.

Sore hands produced by contact with chemicals sometimes give a good deal of trouble. Where a tendency of the sort exists, the photographer should endeavor to keep his hands as much as possible out of contact with chemical solution, and should thoroughly wash them immediately after any such contact. At the close of the day's work the hands should be well scrubbed with soap and a nail brush, and then be moistened with cologne-water to which one-eighth of its bulk of glycerine has been added. This will strengthen the skin, and at the same time retain its softness and pliability. Carbolic acid, five drops to the ounce of water, has been found useful.

§ 11.—Varnishing the Negative.

To varnish a negative well will require both care and attention on the part of the beginner, until by habit and practice a complete control over the operation is obtained.

Choice of Varnish.—First as to the selection of varnish. The beginner should never attempt to make his own, but always procure a reliable commercial varnish. The experienced photographer should always make, never buy; not so much for economy, though the saving is material, but in order to be certain that he has exactly what he wants—a hard, tough varnish, made out of the very best materials. Suitable directions will be found in the latter part of this manual for preparing negative varnishes.

The commercial varnishes may be divided into two classes—the

benzine and the spirit varnishes. The former will sometimes dry clear, even if used cold; the latter always require the aid of heat. On the other hand, the benzine varnishes (so far as the writer's experience goes) always reduce the strength of the negative considerably, whilst the spirit varnishes do not; and the latter are every way more reliable. Either sort that the operator becomes accustomed to he will consider the more easy, and it is best to adopt some particular varnish, and use it always. The writer prefers the spirit varnishes. The two different sorts can always be distinguished by the odor.

Applying the Varnish.—First dust off the plate, either *very* gently with a very soft, broad camel's-hair brush, or by blowing with a bellows. With plates developed with iron, or redeveloped, the latter is the better plan. To apply a spirit varnish, warm the plate gently; in winter a coal stove will be convenient, in summer a gas stove is most commonly employed. Try the temperature by holding it at one corner with the left hand, and moving the right hand under it and applying the side of the hand and back of thumb to various places to see if the heat be uniform. To be right, the temperature should be quite warm, but not in the least hot; there should be a distinct, pleasant sensation of warmth, but no more. If too hot, set aside a few minutes to cool. If used too hot, there is danger of getting *lines*, as will be presently described. If used too cool, the varnish will probably "dry dead." A benzine varnish requires rather less heat than a spirit varnish. Some use it cold when the weather is clear and dry. The writer prefers to use heat with all varnishes. Taking a convenient position in front of a window so as to watch by the reflection all the movements of the varnish, pour it on precisely in the same way as with collodion. Having put on a liberal supply, slant the plate towards you and bring the pool of varnish towards you, *in a full, slow wave*, keep its border *as square as possible*, making it advance slowly and quietly; if one edge gets a little the advance, incline the plate the other way to bring it up. With too little varnish or too much tilt to the plate, long arms will start out, and whilst you are slanting the plate this way and that to get it covered on some part of the border, the wave will stop moving, and a *line* may result.

Having now got the whole plate covered, keep it quite level or even tilt it backward, so as to send a returning wave clear up to the far end of the plate. The varnish should rest on the whole

plate some seconds before *beginning* to pour off, otherwise it will not soak in sufficiently, and so *dry dead*.

The *length of time* necessary for the varnish to rest on the plate varies a good deal. The more a plate has been redeveloped the longer it will need the varnish to remain upon it; the thicker the varnish, the less time is required. A thick varnish with a close film will need only seven to ten seconds. A very thin varnish with a spongy film may need fifteen to twenty. Generally speaking, eight or ten seconds will be a proper time; a few trials on rejected negatives will show what is needed. The time here spoken of is to elapse after the negative has been completely covered.

Having let it soak in sufficiently, incline it *very little*, so that it will run off at the right-hand near corner into the "pouring off bottle" held there to receive it. After it has run slowly for a couple of seconds, the plate being of course nearly level, *bring it suddenly up by a quick movement till it is vertical, and there hold it* for half a minute or more that it may drain and set. Rock it from right to left precisely as in the case of a collodion plate. Let it drain until it almost ceases to drop, and then hold it pretty close to a hot stove until perfectly hard, but not longer than necessary for this. The heat of the stove should be about as great as the hand can bear in holding the plate.

The varnish must of course not be returned into the same bottle as that from which it was poured off, otherwise it will soon have bits of collodion, dust, etc., on it. The writer invariably manages as follows: Take two clean six-ounce vials, fill one with filtered varnish, put on the neck of the other a funnel of about two and one-half inches in diameter, with a paper filter in it. Pour off from the plate into this filter; in this way there will be less varnish lost, and less trouble in getting the stream from the plate into the bottle. The varnish having run through the filter, is of course clean, and when the first bottle is empty, the funnel is transferred to it, and the operation reversed. The funnel with the filter in it may stand permanently in the neck of the bottle, to which it supplies the place of a cork, and so is always ready.

The varnish which has been poured off from plates has of course lost alcohol by evaporation, and is thicker than at first. Therefore before the pouring-off bottle is used for varnishing with, a *little* alcohol must be added—one-sixth or one-eighth its bulk, in round numbers, but this is a point of which the operator

must learn as quickly as possible to judge for himself. If varnish is *too thin* it is apt to dry dead, and does not properly protect the plate. A negative film varnished with a *very* thin varnish can be easily rubbed up by the finger. Such negatives are of course very perishable, and are soon destroyed in printing. If *too thick* it is less easy to work with, and removes the film too far from the paper in printing, thus (especially in shade-printing) diminishing the sharpness of the print.

Some varnishes require heat only before their application; generally, however, they should be dried by heat, as well as be applied on a warm plate. The drying by heat expels the volatile portions more thoroughly, and renders the varnish less liable to become soft and sticky in printing.

The main points are to get the corners covered immediately after you begin to pour, to put on enough, and to bring it down as above explained to a *full, slow, square* wave. The learner cannot pay too close an attention to these directions. By doing so he will get a smooth, even plate. Neglecting them, he will find:—

Ridges.—These start from some point at the edge of the plate and extend some distance over the face of, or even all across the negative. If strong enough to be likely to show in the printing, the plate must be flowed with alcohol, drained, and revarnished.

Lines result from a momentary stopping of the wave of varnish. The varnish dries a little on the hot plate during the pause, and the result is a line exactly marking the position it then had. The hotter the plate, the more apt lines will be to appear. If a line has been made and is seen before you begin to pour off, it may be lessened, and sometimes entirely removed, by keeping on the varnish a few seconds longer than usual before beginning to pour off. *Fine parallel lines* may come from omitting to rock the plate.

Drying Dead.—This results in the production of a film looking like ground glass—sometimes fine, sometimes coarse. If fine, it may not show at all in the printing; if coarse, it will. This may arise from several sources:—

From Dampness of the Film.—After the film is surface dry, it takes a long time to dry through, and the drying must be *thorough* before the varnish is applied. So, too, the film is very absorbent of atmospheric moisture, and even after thorough drying and standing for weeks, may easily in damp weather absorb enough to

affect the varnishing. It is therefore better, so far as convenient, to varnish in clear dry weather, or at least after the plate has remained some time in a warm dry room.

Too thin a varnish may also cause drying dead, or too little applied. If, as soon as the plate is covered, the varnish be poured off again, it will almost certainly dry dead, because the surface only was moistened; this presently soaks in and leaves the film only half saturated with varnish. This is perhaps the commonest of all causes of drying dead, and often (by the beginner) the last suspected. Therefore the writer advises, if the operator is troubled by this difficulty, to proceed as follows: Put on an abundant supply of varnish after covering the plate, send back a wave to the far end, and then hold the plate quite level and motionless for at least twelve seconds quietly counted. At the end of this time, incline the near right-hand corner until a steady stream runs into the bottle, and then, as before directed, bring the end up with a quick motion.

Negatives will be found to vary; some will dry smooth with the very same treatment that gives, perhaps with the very next one varnished, a dead film. This depends upon the *amount of re-development* they have received; the more redeveloped, the more apt to dry dead, because there is more silver powder to soak in the varnish. If found necessary, the varnish may be kept on even for fifteen or twenty seconds, to penetrate thoroughly:

Special care should always be taken not to allow the varnish to get over the edges upon the back of the plate, not only because it is troublesome to clean it off, but because if a stream of varnish runs across the back of the plate, it will often happen that the corresponding part of the *face* will dry dead, the evaporation going on at the back keeps the corresponding portion of the face cool, and thus prevents the drying smooth.

Breathing on the plate may at times, and under some circumstances, lead to spots of deadness.

Often a deadness of the surface will not affect the printing. An experienced operator will be able to distinguish at once whether the evil is great enough to bring about this result. If, when the plate is examined by allowing the light to fall through it, the deadness is not at all or very slightly perceptible, the negative will probably print well.

Revarnishing.—But if the roughness is quite distinct, a remedy must be applied. Since the first edition of this work was printed,

it occurred to the writer to remove the varnish at once by hot alcohol, and this proves to be much the best method.

The defective plate is to be warmed precisely as for varnishing, and then instead of varnish, an abundant quantity of ninety-five per cent. alcohol is poured on and well worked over the plate; this is then poured off and a second portion used to wash off residue. The plate is then allowed a few moments to become quite dry, is heated again, and varnished precisely as with a new plate. This operation, when carefully performed, leaves nothing to be desired in its results.

Ridges, that is, lines of greater thickness extending across the plate, may be easily got rid of in the same way.

When it is intended to print a very large number of positives from one negative, two coats of varnish may be applied. Mr. G. W. Wilson always gives two coats, touching out defects between the two. In this case, the varnish should be thinner than when one coat only is applied.

It is a good plan, as soon as the face of the varnished plate is dry, to draw a piece of blotting-paper along the lower edge of the glass; this prevents the production of a thick ridge there, which would have a tendency to lift up the paper in printing, and prevent a close contact with the adjoining parts.

§ 12.—*Ambrotypes and Ferrotypes.*

If the development of a negative be stopped as soon as all the details are out and considerably before printing density is reached, we have a picture called an *Ambrotype* when made on glass, and a *Ferrotype* when made on a thin plate of varnished iron. The high lights appear white by reflected light, because of the whiteness of the silver deposit of which they are made; the transparent portions are rendered black by black varnish applied on the back, in the case of the ambrotype, and by the black face of the metal in the case of the ferrotype.

All negatives, therefore, in an early stage of their development, are ambrotypes. But to get the best effects, it is found advantageous to use in the negative bath a little more acid, and to employ an old and ripe collodion, for it is necessary to keep the shadows perfectly transparent and free from the least tendency to veil, which would destroy their depth and richness.

An ordinary negative collodion may be used if it is thoroughly

ripe; if not, tincture of iodine may be added till it is sherry wine colored. (Tincture of iodine may be purchased, or may be made by dissolving iodine in alcohol. Thirty grains of iodine to the ounce of alcohol is a convenient strength.)

Some photographers prefer a special collodion containing iodide of potassium, now rarely used in negative collodions. Mr. Thomas, of New York, uses the following proportions:—

Iodide of potassium	50 grains.
Bromide of potassium	30 “

Dissolve these salts, with the aid of heat, in 3 ounces of alcohol, Take 60 grains of pyroxyline, dissolve it in 5 ounces of ether and 2 of alcohol. Then add the above while still hot.

The developer is to be the same as for negatives, taking care that it be sufficiently acidified, for which purpose one-half more acetic acid may be added than for negatives.

§ 13.—General Remarks.

Avoid doing anything which may cause dust in the dark room. Keep the dark slide clean and well wiped.

Notice the camera from time to time to assure yourself that the wood work is close and tight.

See that the focussing slide sits tight and close up. The spring that holds it to the body of the camera will sometimes get out of order and affect the two slides differently, so that one comes up more closely than the other. The result of this will be that the focussing surface no longer corresponds with the sensitive film, and no matter how carefully the focussing be done, the pictures will not be accurately sharp.

Make sure that the camera-stand is absolutely steady and not given to trembling.

See that the dark room is thoroughly ventilated, so that whilst at work you are not inhaling noxious vapors, and as little as possible of the fumes of collodion.

Removing stains from hands.—Fresh stains come away much more easily than those that have been exposed to light. Dilute hydrochloric acid, to which a little solution of bichromate of potash is added, is very effectual. It should be followed by an application of a vegetable acid, tartaric, citric, or better yet, binoxalate of potash, which last is also convenient for removing ink stains. One or more of these substances should be kept at hand in solu-

tion to use after the bichromate solution, which otherwise leaves behind a yellow stain and disagreeable odor; the injurious effect upon the skin is also diminished. Perchloride of iron, which has been recommended, the writer has not found to answer. Cyanide of potassium should not be used. *Silver stains on clothes* are best removed by solution of corrosive sublimate, which destroys them effectually and without injuring either the texture or the color.

CHAPTER III.

PRINTING.

§ 1.—Sensitizing.

As *albumenized paper* is now almost exclusively used in positive printing, it will be the only method described in this introduction; others will be hereafter given.

Those who operate upon a large scale sensitize their sheets whole, others divide them into halves or quarters, and one corner

Fig. 11.

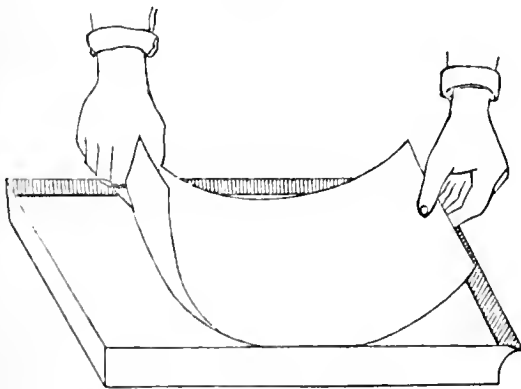

Laying the sheet on the printing bath.

is to be folded backwards for half an inch or three-quarters. The piece is then held at its two ends, is folded into a loop by bringing the hands somewhat together so that the centre will be lowest, and the albumenized surface undermost. The centre of the sheet is made to touch the bath first, and then, by opening the hands and lowering them, the whole

surface is regularly opened out on the bath. In this way air-bubbles are avoided. Should an air-bubble remain under the paper, its place will be marked by a white spot in the print.

Positive Bath.

Water	22 ounces.
Nitrate of silver	3 "

The paper remains on it about four minutes in winter, and two in summer. It is then lifted off by the corner turned up, and

pinned to a rod or string to dry. A convenient method is to take a long strip of wood, and glue on it at spaces corks, into which to stick the pins.

When the bath turns dark, shake it up with half an ounce of kaolin. Let it stand some hours, with occasional shaking, and filter.

Examine the bath from time to time with red and blue litmus paper, and keep it as nearly neutral as possible. If the blue litmus turns red, the bath is too acid, and may be neutralized with a grain or two of bicarbonate of sodium. If red litmus paper turns blue, the bath is alkaline, and a little dilute nitric acid must be carefully added. It is best to have the solution an inch deep in the glass or porcelain bath. Too shallow a bath tends to irregular action.

See that the paper is thoroughly dry before printing it. A dense negative prints best in the sun, a thin one in the shade. That is, it is to be exposed at a window to a good light, but not to sunshine. A negative too thin to give a good result in any other way, may often be successfully printed by laying a sheet of tissue paper over it.

Printing frames are made in many different patterns. The writer recommends the *bar frame* (Fig. 12) to the exclusion of all so-called improvements on it, which generally fail to bring the paper closely up to the negative, unless the pressure is dangerously increased. The padding behind the paper should be of soft woollen material, felt, or, best of all, *piano-cloth*.

Print till the highest lights *just begin* to color. By this time the dark shadows ought to show the greenish, almost metallic, look known as "bronzing."

Examine the print from time to time, taking the frame to a darker part of the room, open the back gently, taking care not to shift the print, bend it back, and judge of the degree to which the printing has gone.

As fast as the exposure is finished, throw the prints into a dark drawer.

Fig. 12.

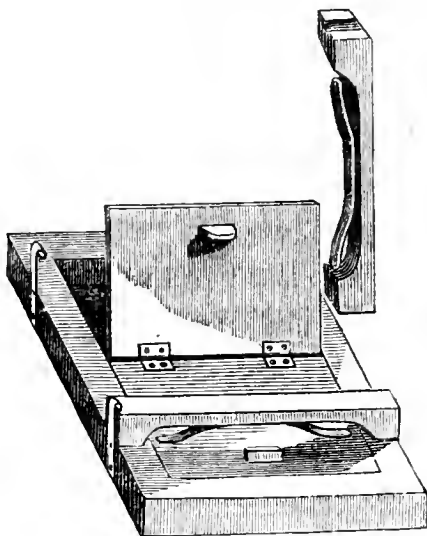

When all are ready, proceed to wash them by putting them *one by one* into a basin of water, where they lie ten minutes. This water is to be carefully added to the residues, as it is rich in silver. Change the water two or three times, then tone.

As the printing-bath will continually lose in strength, it should be kept up by adding crystals of nitrate of silver, remembering that each sheet of 18×22 will remove about a drachm and a quarter of nitrate of silver.

§ 2.—Toning Bath.

Water	16 ounces.
Chloride of gold	4 grains.
Acetate of sodium	1 ounce.

If mixed with warm water, it will in two or three hours be ready for use, otherwise it is best kept till next day. In very cold weather, a little more gold must be used; and the bath, except in hot weather, should be warmed till it is tepid.

Put in only a few prints at a time, and keep them constantly moving about. When they reach the shade desired, let them remain a little longer, as they will afterwards recede a little in color; then take them out, pass them through clean water, and proceed to fixing. This bath will give rich warm tones, but not black ones, for which, if desired, the carbonate bath, or better, the chloride of lime bath (see beyond), must be used.

Prints that look blue when finished, have been *over-toned* by too long an immersion.

§ 3.—Fixing Bath.

Water	32 ounces.
Hyposulphite of sodium	4 "

Keep the prints moving about in this, and leave them in fifteen minutes. The above bath will suffice for two whole sheets, and must be increased in proportion if more are to be toned. *Never use on any subsequent day a bath that has had even only one single print fixed in it, or the print so toned will surely fade in time.*

§ 4.—Washing.

A very thorough washing is needed to prevent fading. Prints thrown into a tank into which a tolerable stream of moving water falls, will be sufficiently washed in six to ten hours, provided there are not too many of them. When the number is large, the tank must be continually emptied of water and refilled.

CHAPTER IV.

A FEW GENERAL RULES FOR BEGINNERS.¹

1. INVARIABLY wash the fingers under the tap immediately after they have been in *any* solution, but most particularly after hyposulphite. Neglect of this will transfer portions of one solution to another, and lay the foundation for long series of failures, which may prove utterly distressing and perplexing.

2. Do not be actuated by an ambition to commence with difficult work. Point the camera out of the window, and take the view, such as it is, until it is done with certainty and success. After that will be time enough to try portraiture—last of all, copying.

3. Begin with small plates, and do not try large ones until the smaller are mastered. Half-size will be the largest proper to begin with.

4. Do not undertake to make collodion before its use is learned. Be satisfied to purchase that which some experienced friend recommends.

5. Do not tend towards intensifying thin pictures by after-treatments. When photography was less understood this was oftener necessary. It is better to wash off and begin again, and generally less trouble to get a better result.

6. The quickest way to learn is this: take any simple object as above, a brick house, for example, and try it again and again, varying the length of exposure and the length of development, until a negative is got that prints exactly right. This will teach more in a few mornings than as many weeks of random work.

7. Successes that come by chance are worthless, and prove nothing as to ability. Try to know exactly the causes of success and of failure.

8. The right exposure may often be got the first time, but not

¹ At the end of this volume will be found descriptions of those simple chemical manipulations which are used in photography, and with which the beginner will do well to make himself early familiar.

certainly; yet a careful examination of the first trial ought to enable one to make sure of the second.

9. If the camera needs to be placed in the sunshine, throw the focussing cloth over it before the shutter is drawn out to make the exposure. The direct light of the sun may find its way through cracks too small to admit diffused light.

10. Once in a while wipe out the camera with a damp cloth to remove dust, which by settling on the plate may cause pin-holes or comets.

11. Treat the lenses with *the utmost* care. Never leave them about; never wipe them with anything but the softest old linen cambric, perfectly clean, and not even so except when needed.

12. Do not unscrew the tubes unnecessarily to wipe the inside surfaces of the lenses, or for any other purpose, and always do this in dry weather, or damp air will be admitted, which will be apt later to leave a dew on the lenses. If any of the lenses are set loosely in the tube, be sure they are replaced with the same side front as before.

13. Do not let either the lenses or the camera stand in the sun, the result will be warping and splitting of the wood, and discoloration of the lens.

14. Be sure that the camera stand is free from vibration. Uncover the lens very gently so as not to shake the camera in the least, or the definition will be impaired.

15. Unless the ground glass is of the best, the focus cannot be taken with accuracy. Much of the ground glass in cameras made for sale is very poor. The glass should, in fact, not be ground at all, but only "grayed," that is, have its surface removed by rubbing with fine emery powder. Focus a brick house 200 feet off with a short focus lens, and if the white lines of the mortar cannot be seen, either with the naked eye or with a magnifier, the glass is too coarsely ground; and it is to be expected that all the work done with it will be inferior.

16. Focussing with a microscope is less trying to the eyes, and gives sharper work. The larger the lens of the microscope used, the less the eye is strained. An engraver's glass set in horn is good, but a similar one, an inch and a half or two inches in diameter, tires the eye still less.

17. Learn exactly how to make a negative bath, and then avoid doctoring. For the most part it will only be injured. Add a very little carbonate of soda, and sun it, if out of order, for some

hours in direct sunlight, then filter and acidulate as directed for a new bath. Filter first, then acidulate.

18. Decaying organic matter, foul smells, sulphuretted hydrogen, and fumes of ammonia may be expected to produce fog.

19. Do not think it necessary to have the dark room too dark. There may be light enough to work with perfect comfort, and the strain on the eyes in going backwards and forwards will be so much the less: an important consideration.

20. Have nothing to do with cyanide of potassium. It is a substance of which the photographer has no real need. If used at all, it should be left to those who have learned their experience on less dangerous materials.

21. Remember that most chemicals are poisons, and that if the fingers are not washed immediately after being plunged in them, or if, even with this precaution, they are kept long in the solutions, mischief may ensue. What this mischief may be is of so gradual and insidious a nature, as to be ascribed to any other cause than the right one.

22. Remember also that most fumes are injurious. Vapors of ammonia disorganize and paralyze the blood corpuscles. Vapor of ether is very injurious to the nervous system, produces headache, and depresses the whole tone of the body. Nitric acid is highly poisonous; its fumes, when inhaled for a sufficient length of time, will cause death.

23. Therefore make every provision for thorough and complete ventilation. And do not fancy (as many most unwisely do) that because the senses become habituated to such fumes, and cease to be inconvenienced by them, that the system is therefore not suffering.

24. Adopt invariably the maxim, that whatever is worth doing is worth doing well. Practice never makes perfect without care, and thoughtful and intelligent observation. Some will do a thing all their lives, and always badly.

25. Acquire the habit of rinsing out all the vessels as soon as emptied, and of not leaving the adhering portions to dry on the bottom and sides, when it will take five times the trouble to get it out.

26. Make it a rule to wash every vessel before you put it away, and again before using it. Never trust to *anything* being clean, but make it so. If there is any one thing that is essential in photography, it is care of this sort. The delicate reactions on

which photographic processes depend are sufficiently exacting, without further embarrassing the processes by introducing foreign matter of unknown nature.

27. Never forget that no vessel is rendered clean (even if what it has contained has been merely an aqueous solution) by simply pouring water in and throwing it out.

Hold therefore the vessel, whether beaker, bowl, bottle, or whatever it may be, under the tap, so that the water may run over *every* part, inside and out. Outside, because it is never certain that a glass vessel is clean *inside* unless it has also been made so outside. Remember that if a vessel be hastily rinsed out, there may be left drops of the old solution adhering to the sides above the part washed, and that a single drop so left may spoil the following operation. This direction may be thought so much a matter of course as to be superfluous; it *is not so*.

In all cases, except where the old contents are very easily removable by water, employ the bichromate cleaning solution, which for this purpose may be made of double or treble strength, so as to work more energetically.

28. In the field, before making the first exposure, take pains to make sure that *everything* is right. (See especially sections 3 and 4 in chapter on Landscape Photography.)

29. Make it a fixed rule that every failure shall be made the stepping-stone to some new advance. If by accident any work is destroyed or injured, make it a rule that it shall be replaced with *better*. The result will be that, instead of feeling that time has been lost in merely remedying an accident, there will be a feeling of congratulation that that very mischance was converted to an advantage.

Again, instead of falling into a routine of work from time to time, consider whether there may not be some better mode of operating, and if a probable improvement suggest itself, or is suggested by others, give it a fair trial.

On the other hand, beware of capriciously changing about from one process to another. There are often several good ways of doing some one thing, any one of which well done is better than any other unskilfully carried out. It is best, therefore, to acquire a thorough knowledge of some good means of managing each operation—this gives firm foothold. Experiments in other directions then will be compared carefully with the regular plan,

which will never be abandoned until by repeated trial the new method has shown itself distinctly superior.

30. Success will very often depend upon the willingness to make another trial, for want of which many barely fail.

31. Finally, the beginner in Landscape Photography is earnestly recommended to act upon a definite system. For example, let him not run from one lens to another, but rather, having provided himself with one thoroughly good one, let him study out its capabilities and learn exactly how to use it. Different lenses work so differently, that, to the beginner, they are very confusing, and tend to conceal from him the sources of the mistakes and faults that he must necessarily make. Only in one way can he usefully employ himself with several lenses, and that is by using them in succession to take the same view, and observing and studying closely the differences in the results.

The secret of success lies in taking up separately each different portion of the work and mastering it by careful study. First take the view from any convenient window until you can do it with regular and complete success. Next select some attractive landscape, and try it upon different points, and with varying lights, and longer and shorter exposures, until you have done with it the best that it admits of, and until you know *why* such a result is the best that can be attained. One such piece of negative-making, worked thoroughly out, will teach as much as thrice the time spent in random view-taking. The student should bear steadily in mind that whilst a thoroughly good negative is very valuable, there is nothing more worthless than a tolerable one. A tolerable negative is not worth the trouble of printing, and is consequently worth nothing at all.



PART II.

PHOTOGRAPHIC OPTICS AND THEORY OF PERSPECTIVE.

CHAPTER I.

GENERAL OPTICS.

§ 1.—Reflection and Refraction.

WHEN a ray of light (this expression will be more convenient, although wave of light would be more correct) falls upon any surface, a part is reflected and a part transmitted.

Let the ray AO (Fig. 13) pass from the rarer medium on one side of the surface EF into the denser on the other; for example,

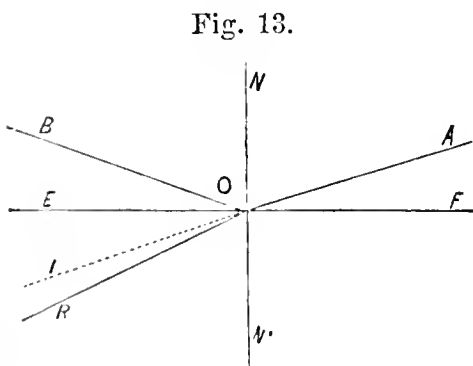

Fig. 13.

out of air into glass. Part of the ray will be reflected and part refracted. In order to study these phenomena, we draw a line perpendicular to the surface EF at the point of incidence O . This line NO is the *normal*, and the angle AON between the incident ray and the normal is the *angle of incidence*.

We find that the *reflected ray makes the angle of reflection BON equal to the angle of incidence AON* .

The *refracted ray is bent out of its course towards the normal*. In place of continuing on in its direction AOI , it is deflected towards the normal NN' , in some direction OR , and the quantity of deflection depends upon the character of the substance. The greater the deflection, the higher the refractive power is said to be.

In the foregoing we have considered the case of a ray passing

from a rarer medium into a denser. In the converse case the converse result takes place. If in the above figure we suppose the directions to be reversed, and that the ray RO passes at O from the denser medium into the rarer above it, then the ray RO will be bent *away from the normal* to precisely the same extent, and will follow the path OA .

It therefore follows from this that when a ray passes from a rarer medium into a denser, and then through the denser again into the rarer, it will emerge in a direction *parallel to that in which it entered*, provided that the denser medium has parallel sides.

The ray AD (Fig. 14), in passing through the denser medium, takes the course DB , being deflected towards the normal, and, on emerging, again assumes a direction BC parallel to AD .

Fig. 14.

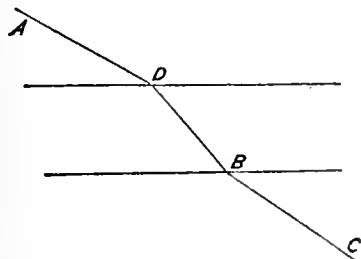
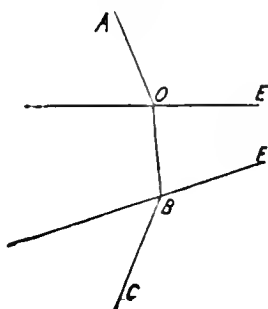

Fig. 15.



But if the sides of the denser medium are not parallel, the ray will not emerge from the second surface parallel to its first direction. Thus the sides OE, BF (Fig. 15) of the denser medium not being parallel, the ray AO , in passing through the surface BF , takes a different direction BC .

Different substances refract the rays of light very differently, and are therefore said to differ in refractive power.

We have a very convenient method of measuring refractive power, which is as follows:—

In Fig. 16 let $S'S''$ be the boundary line between an upper and rarer substance and a lower and denser one. Let any ray of light RO pass at O out of the rarer into the denser, and let the line OR' represent its deflected direction.

With any distance OA as a radius, draw the curve $AN'R'$. Draw at the point O the normal NN' , and from the intersection A let drop the perpendicular AS , similarly from R' the perpendicular $R'S$.

AS will be the sine of the angle of incidence and $R'S$ the sine

Fig. 16.

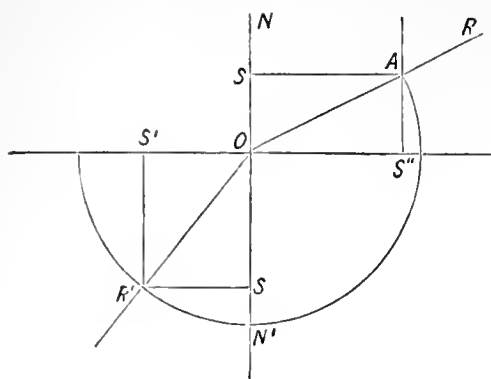

of the angle of refraction. Each of these angles will be conveniently measured by its sine.

Now it is found that when any two given substances constitute the rarer and the denser medium, the proportion between the lengths of AS and $R'S$ is invariable, whatever be the angle of incidence. If the upper medium be air and the lower a

certain quality of glass, the sine of refraction $R'S$ will always be exactly two-thirds the sine of incidence AS , let the ray fall upon the dividing line $S'S''$ at what angle it may.

The ratio of the sines is then invariable for any given substance, and this ratio is called the *index of refraction*. In the case just mentioned AS being to $R'S$ always as 3 to 2, the index of refraction of such glass is said to be $\frac{3}{2}$ or 1.5.

The path which will be taken by any ray in passing from one medium into another can easily be traced as follows: Let the ray RO pass out of air (or rather out of a vacuum, but the difference is unimportant here) into glass of refractive power 1.5. Draw the normal NN' through the point of incidence and perpendicular to the surface. Set off any distance OS' , and, taking this as unity, make OS'' equal to the index of refraction. In this case OS'' will stand to OS' in the proportion of 1.5 to 1. Draw the perpendiculars $S'R'$, $S''A$. Putting one leg of a compass at O and the other at A (the intersection of $S''A$ with OR) draw the curve AR' , the intersection of this curve with $S'R'$ when connected with O gives the path of the refracted ray.

§ 2.—Dispersion.

In the foregoing section we have reasoned as if light were homogeneous. But white light is made up of rays of very different refrangibility, so that when a ray of white light AD (Fig. 17) passes at D into the denser medium bounded by the line BC , these rays are differently affected. The more refrangible rays are bent more out of their course, following the direction DF ; the less take the direction DE .

On reaching the second surface BD , if this surface is not

parallel to the first, but inclined to it, these different rays will have their divergence greatly increased, and will be spread out as there represented.

Fig. 17.

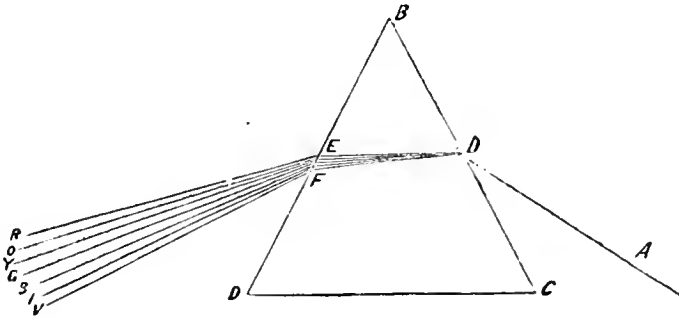

We find that a difference of color accompanies a difference of refrangibility, the most refrangible being violet, and so proceeding in the order, violet, indigo, blue, green, yellow, orange, and red. Under very favorable circumstances, and with well-exercised eyes, a commencing disposition to repeat this gamut, like octaves in musical sounds, is observable, far beyond the red a crimson tint has been seen, and beyond the violet, a lavender.

But, independently of these, the existence of non-luminous influences beyond the limits of the visible spectrum is easily detected. Beyond the red rays, rays of *dark heat* are made evident by the thermometer, and beyond the violet there exists rays also invisible, but having a powerful chemical effect, so that in a portion of space completely dark, sensitive paper is rapidly impressed.

Whilst rays, invisible to our eyes, are thus capable of exerting powerful actinic action, other rays, plainly and even brilliantly visible, exercise little or no actinic influence. The yellow and red rays, in which the chief illuminating power of light resides, scarcely act upon sensitive substances. The green rays exert an influence on some and not on others.

It is not a little remarkable that sulphate of quinine possesses the power of lowering the refrangibility of the rays beyond the violet, and thus rendering them visible to our eyes. If sulphate of quinine be dissolved in water acidulated by sulphuric acid, and the solution be placed in the dark rays beyond the violet, these become visibly blue.

CHAPTER II.

OF LENSES.

§ 1.—Nature of Lenses.

A LENS may be plane on one side and convex on the other—plano-convex. (Fig. 18.) Plane on one side and concave on the other—plano-concave. (Fig. 19.) Convex on both sides—double convex. (Fig. 20.) Concave on both sides—double concave.

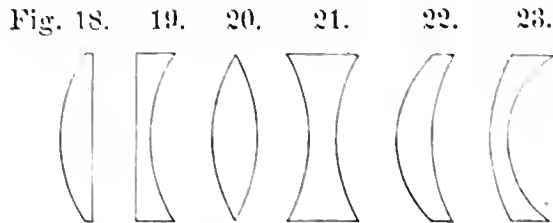

(Fig. 21.) Concave on one side and convex on the other—meniscus. The meniscus may be of two sorts. If the radius of the convex side is the shorter, the lens is thickest in the middle, and is called a positive meniscus. (Fig. 22.) If the concave curve has the shorter radius, the meniscus is thickest at the edges, and is termed a negative meniscus. (Fig. 23.)

To understand the action of a lens on rays of light, let us select a plano-convex lens and consider its properties.

Fig. 24.

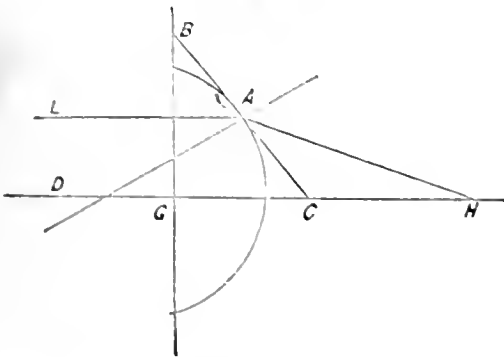

When a ray of light LA falls upon any curved surface at any point A , we draw a tangent BC at the point A , and we may then consider the solid body AG , as far as the ray LA is considered, not as a body having a curved surface, but as a prism

BGC , for it will act towards the ray LA precisely as if it were such a prism. The ray LA passing out of it will be sent away from the normal in the direction AH , and will intersect the axis DH at a point H .

Let us now consider several rays of light LJ' , &c. (Fig. 25.) L strikes at the centre of the curve, where the tangent is parallel to the plane side AB , and is therefore influenced precisely as if

Fig. 25.

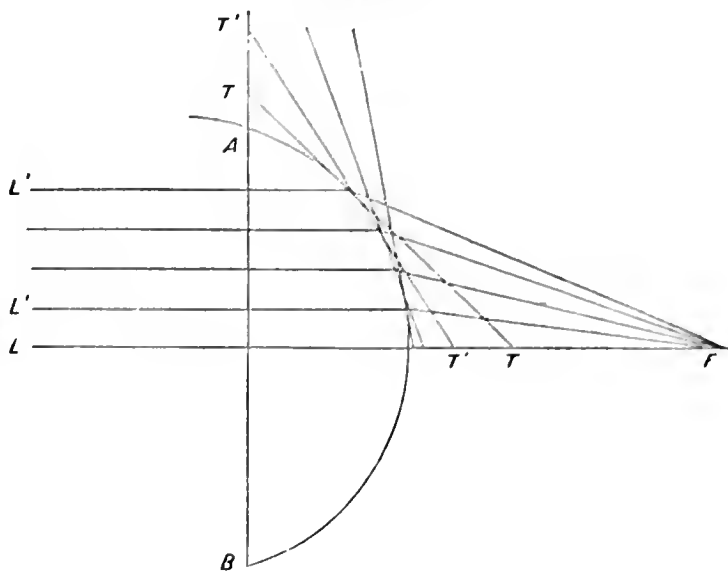

it passed through a piece of plane glass, and emerges in the same right line. J' is bent on leaving the curved surface, and tends towards F . Other rays strike the curve still higher from the axis, where the tangents are still more inclined, and are therefore still more deflected. This greater deflection makes up for the fact that the original path of that ray was farther from the central ray, and thus all the rays approximately tend to gather together at a point F , called the focus.

What is true of the plano-convex lens, is true of all lenses that are thickest in the centre, of double convex and of positive meniscus lenses. Those lenses which are thinnest at the centre are called negative. They do not collect parallel rays to a focal point, but cause them to diverge. They have no real focus, but only a virtual one. Such lenses taken alone would be of no use in photography, but they are often employed in connection with others.

If matters passed exactly in the manner above described, the construction of photographic objectives would be far more simple than it is. But the spherical lenses which we use are liable to faults, which will next be considered.

CHAPTER III.

FAULTS INCIDENT TO SPHERICAL LENSES.

THERE are five distinct sources of inaccuracy in the image formed by a spherical lens. These are, SPHERICAL ABERRATION, CHROMATIC ABERRATION, ASTIGMATION, CURVATURE OF THE FIELD, and DISTORTION.

§ 1.—Spherical Aberration and the Modes of Remedying it.

All lenses in use at the present day have their curves, parts of spheres. Now it is a property of all spherical curves $A B$, Fig. 26, that they do not bring the rays exactly to a point at F . Just in proportion as the parallel ray L' is further from the central axis L , so is that ray, after passing through the lens, brought down to the central axis at a point nearer to the lens. The focal length F' for the ray L' is shorter than the length of F for the ray L , and so on.

It will be seen, then, that for the spherically curved lens $A B$ there is no real focus, but a succession of foci all the way from F to F' , and although the fault is intentionally exaggerated in the figure, it is still so great as imperatively to require attention.

Fig. 26.

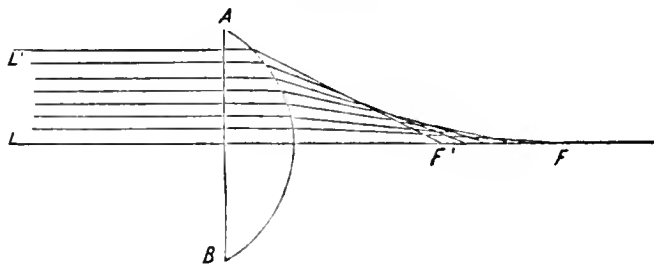

Spherical aberration may be destroyed, or at least diminished, in two ways. Either lenses may be so combined that their aberrations will be in opposite directions, and so compensate and destroy each other, or else diaphragms may be employed.

Correction by Diaphragms.—The ray $R'' A$ which would come

to a focus at a point F' nearer to the lens than F (see Figs. 26 and 27) is cut off by the diaphragm CD . We thus greatly in-

Fig. 27.

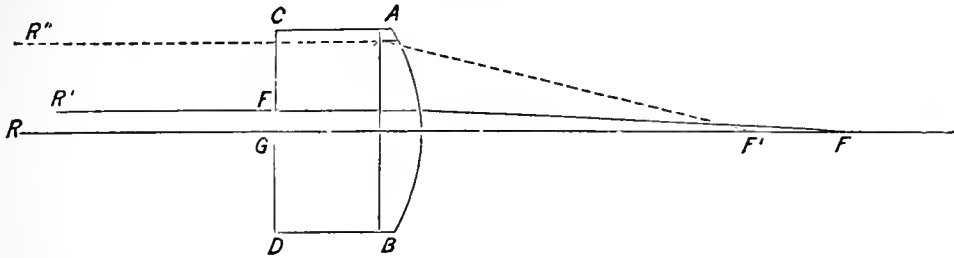

crease the sharpness of definition by the use of a stop, though of course at a great sacrifice of light. Thus, if the lens is two inches in diameter, and the aperture of the diaphragm is a quarter of an inch, then, as the areas of circles are at the squares of their diameters, the loss of light is $\frac{63}{64}$, or only one sixty-fourth part of the whole light which would reach the sensitive film, if a full aperture could be employed, is left available.

Although this loss of light is a most serious evil, it is necessarily submitted to, and we gain that the image, before dull and hazy, becomes at once sharp and crisp. Before, the lens seemed to have no true focus; now, for any given object, the focus can be found with exactitude.

§ 2.—**Chromatic Aberration and Mode of Correction.**

Spherical aberration is independent of the nature of the light employed; it results wholly from the form of the lens, and occurs even with homogeneous light. We have next to consider a sort of aberration arising from the different indices of refraction of the different rays of which white light is composed.

When considering the subject of dispersion, we saw that when light fell upon a prism, it was spread out into a spectrum, in which its different constituents were arranged in the order of their refrangibility. And as a lens may be taken to represent a number of small prisms, it follows that the same spreading of the colors will there take place.

If, as in Fig. 28, a perpendicular ray of light strikes a plano-convex lens at A , it passes into it unchanged; but at B the dispersion of the rays takes place according to their refrangibility, and the focus of the violet rays is nearer to the lens than that of the less refrangible rays at the red end of the spectrum. The

distance between these two foci V and R is called the *chromatic aberration*, which in the figure is necessarily exaggerated for clearness.

Fig. 28.

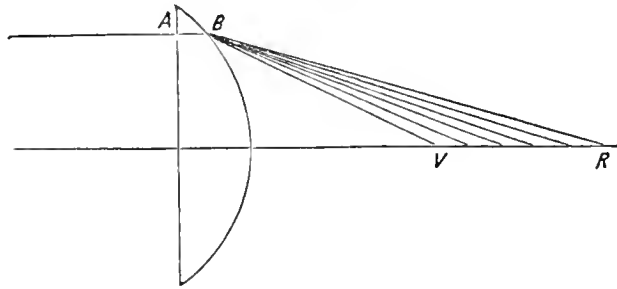

This fact may be easily rendered visible by holding such a lens in the sunlight. Rays of white light LL (Fig. 29) are divided,

Fig. 29.

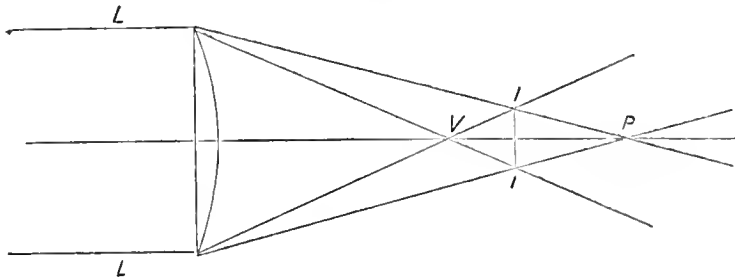

and the violet rays find their focus at V , the red at P . If a white screen be interposed anywhere between the lens and the point I , there will be a circular image of the sun with a red border; beyond I , where the violet rays cross the red and pass outside, the image will have a violet border. The distance VP along the axis between the foci of the red and violet is termed the *longitudinal aberration*, and that at II the *lateral aberration*. II is the place at which the least circle encloses the whole of the rays, it is therefore the best focus.

To understand clearly how the chromatic aberration is corrected, it is necessary to bear in mind that the *refractive* power of substances and their *dispersive* power are not proportionate to each other. For substances may exist of equal refractive power, and different dispersive, and conversely.

Let us, then, take two sorts of glasses, and construct a double convex lens of that sort that has the least dispersive power. Next let us form a negative lens (*i. e.* one thinnest in the middle) of a sort of glass having a much greater dispersive power, and let us

so regulate its curves that it shall exactly compensate and destroy the dispersion of the first lens (by introducing an equal dispersion in an opposite direction). As the negative lens had a higher dispersive power than the double convex, it will, whilst removing wholly the dispersion of the latter, leave it a residue of refraction. So that the compound lens (Fig. 30), although its dispersive power has been destroyed, is still capable of converging rays to the focus. This is now an *achromatic lens*. It is not necessary that the negative lens should be double concave, as in Fig. 30. It may be plano-concave, and may be combined with a plano-convex (Fig. 31), or a double convex (Fig. 32).

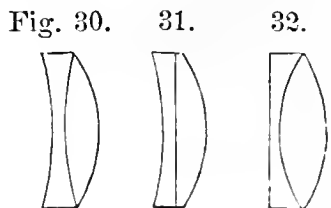

§ 3.—Astigmatism.

Astigmatism is produced in those pencils of light that fall obliquely upon the lens.

Let $C D E F$ represent the *face* of a lens, not a section as usually shown in the figures. Let $R R, R' R', R''$ be rays of

Fig. 33.

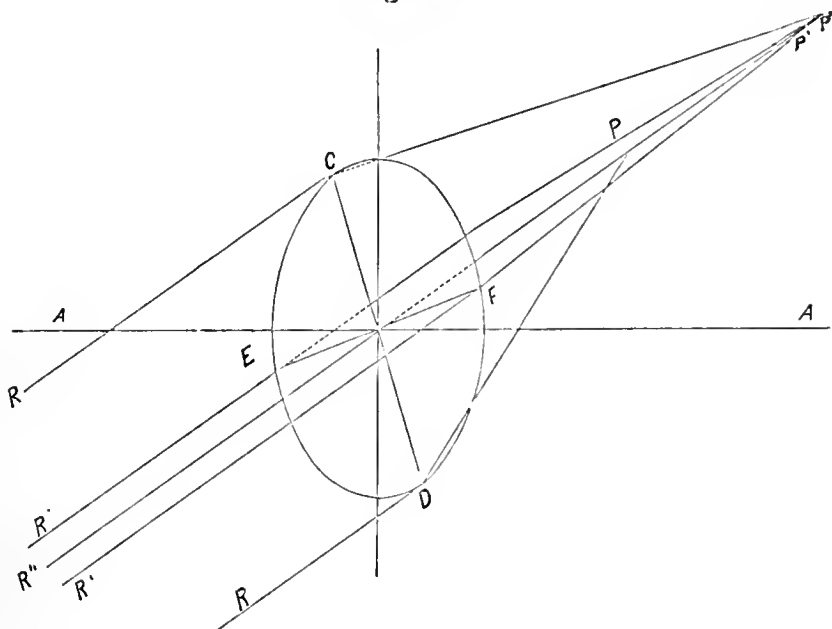

light coming from an object so distant that they are parallel. Let the central ray R'' pass through the optical centre of the lens; it will emerge parallel to its original direction; its prolongation in the direction p will constitute a secondary axis. Let $E F$

be a diameter of the lens, perpendicular to the axial ray R'' , and CD another diameter at right angles with the first. Now the rays $R' R'$, which reach the lens at E and F , strike it under absolutely the same conditions. They will, therefore, undergo equal refraction, and will meet the secondary axis at some point P' .

But this is not at all the case with the rays $R R$, which fall on the ends of the other diameter CD . They will strike the curved surface of the lens under very unequal angles, and will be very differently refracted. $R D$ will reach the axis at some point P , $R C$ at some point p .¹

But the use of a diaphragm cuts off $R D$ and the neighboring rays. Of the rays that are left, $R C$ and the neighboring rays have their focus at p , whilst $R' E$, $R' F$ have their focus at p' .

It follows, therefore, that oblique pencils have no true focus. For if p be taken as the focus, then the rays $R' E$, $R' F$ will have crossed at p' , and at p they will have widened out again, and the image of the radiant point, instead of being a point, will be an ellipse, having its major diameter in the direction EF . Conversely, if p' be taken as the focus, $R C$ and the neighboring rays will not have converged to a focus, and their section on the focusing screen will form an ellipse, having its major diameter in the direction CD . In neither case will the point have its image as a point, hence the name astigmatism (α , no, and $\sigma\tau\iota\gamma\mu\acute{\iota}$, point). The image of the point will appear as an ellipse, whose greatest diameter will change its direction according as the focussing screen is farther or nearer to the lens.

Rays incident perpendicularly upon the lens, do not produce astigmatism. If, then, we examine the case of a pair of lenses having convex surfaces outside, and a stop between them, we shall see that if this stop be placed at the centre of curvature of the outside surfaces, then only rays of incidence nearly perpendicular to the surfaces of the lenses will be permitted to pass through the stop. Lenses with central stops, will have less or more astigmatism, according as their central stop corresponds more or less nearly with the centre of curvature, and as its opening is smaller.

¹ The unequal refraction of $R C$, $R D$ is the cause of *coma*, which will be presently treated of.

In the single meniscus view lens, the astigmatism will be less in proportion to the depth of concavity of the front surface. It will also be controlled by the position of the front stop. The nearer this is placed to the centre of curvature of the front concave surface, the more nearly will the incidences be perpendicular, and consequently the less the astigmatism.

Fig. 34.

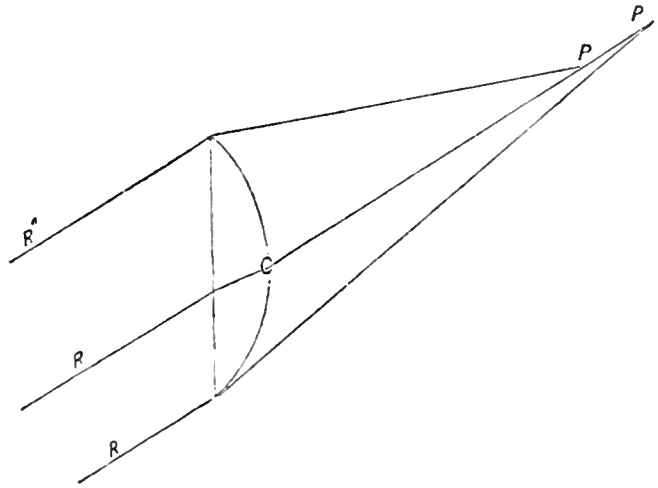

Coma. — Spherical aberration is much more easily removed for direct rays than for those that strike the lens in an oblique direction. Let the rays $R R' R''$ strike the plano-convex lens in an oblique direction. One ray, R' ,

which, after refraction at the first surface of the lens, passes through the optic centre C , emerges in a direction parallel to that which it originally took. This line CP' is the axis of the refracted pencil. The ray R'' meets the axis at P , whereas the ray R meets it at P' farther on. Thus whilst the rays corresponding with R are gathered at the point P' , those corresponding with R'' are spread out below it constituting *coma*. (Fig. 35.)

Fig. 35.



This incorrectness, like so many others, is kept within bounds by the use of the diaphragm, which in the above case would cut off the ray R , and permit only such to pass as would converge on the axis CP to a single point, P , or to a sufficiently near approximation.

§ 4.—Curvature of the Field.

If we suppose an object of some size placed before a lens, we shall find that its extremities do not come to focus on the same plane as its centre.

The arrow C is supposed to be so distant that its ends and centre may be regarded as equally far removed from the lens. Now if the centre of the arrow C has focus at C' , its extremities will have their focus not in a plane perpendicular to the axis of

Fig. 36.

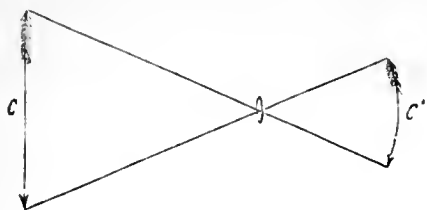

the lens, but at points nearer to the lens. The whole image, therefore, will not fall upon a plane, but upon a concave surface. As it is necessary that it should be rendered flat, we shall consider the means of doing this by the conjoint operation of the

diaphragm and the correction of the lens.

Diaphragms.—If a diaphragm or stop were placed immediately in contact with a lens, it would virtually reduce the lens to one the size of the diaphragm. But the diaphragm is always placed some distance away, and then every part of the lens concurs in forming the picture, but each part is only permitted to act upon those rays for which it is intended.

Fig. 37.

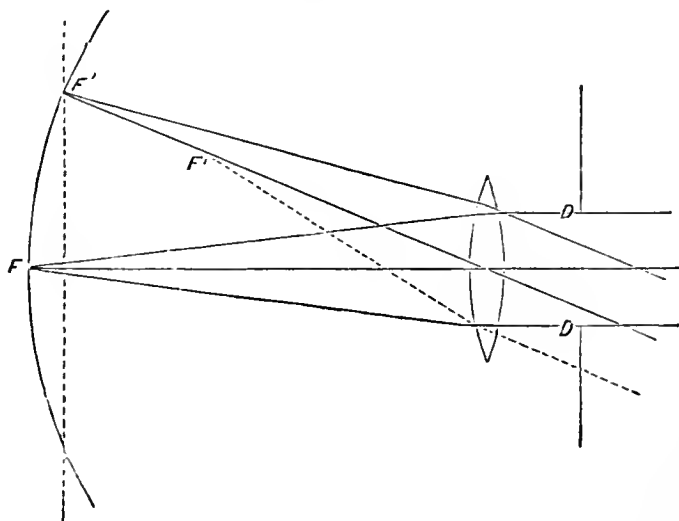

By the interposition of the diaphragm, the dotted oblique ray, for example, which would reach its focus at a much nearer point, is cut off, and only those rays are permitted to pass which meet at a focus as nearly as possible in the plane in which the central rays find their focus at F . Here is at once a valuable approximation towards a plane field.

Moreover, by virtue of the stop the rays which form the image meet with a very small angle, and it is evident that the focussing screen may be brought into such a position that all parts of the image will be very good focus at the same time.

This is *flattening the field by use of the diaphragm*.

Correction.—But the field may also be flattened in the same manner that the correction for chromatic aberration is applied.

In the simple lens the field is very curved. If we now add the correcting negative lens to remove the color, we shall lengthen out the oblique pencils *more* than the central.

This is flattening the field by correction of the lens.

§ 5.—Distortion.

The mathematical conception of a lens regards it as consisting merely of its bounding planes, and destitute of thickness. If lenses actually possessed this form, the images produced by them would correspond strictly with the principles already laid down. But all lenses necessarily possessing a definite thickness, the image is thereby deformed, unless special measures be taken to correct such distortion.

Every right line, no matter what be its inclination, if it be directly in front of the lens, so that the prolongation of the axis of the lens passes through it, is imaged on the screen as a right line, whether perpendicular, horizontal, or inclined, because of its symmetrical position with respect to the different parts of the lens.

But if the line be not symmetrically placed, that is, if the prolongation of the axis of the lens do not pass through it, then the image of such a right line will be curved, with its concavity turned towards the axis of the lens, and a square, for example, will be represented as in Fig. 38.

This is termed *barrel distortion*, and is seen in the single view lens.

The *position of the diaphragm* has necessarily a strong influence on distortion. When the diaphragm is in front of the lens, as in the case of the view lens, the crossing of the rays takes place in front of the lens, and the lower part of the lens receives the rays from the upper part of the object, and the distortion is barrel-shaped. If the diaphragm be placed behind the lens, the crossing of the rays takes place *behind* the lens, and the lower part of the lens receives the rays from the lower part of the object. If now we take the case of two lenses with a stop between, as in photographic doublets, the one compensates the other, and the distortion disappears completely if the lenses be exactly similar and the stop be placed equidistant from each.

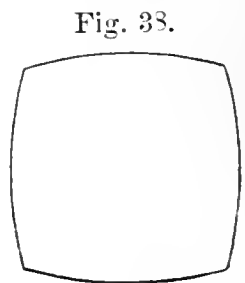

Falling off of Intensity at Edges.—In addition to the foregoing faults incident to lenses there is the defect introduced by the dia-

Fig. 39.

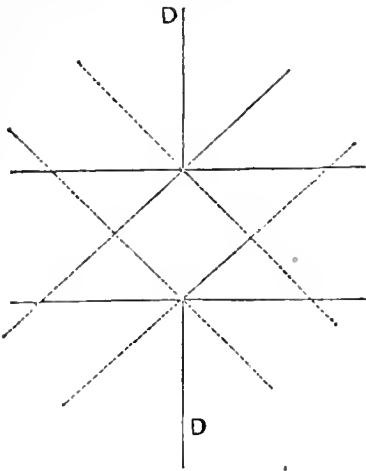
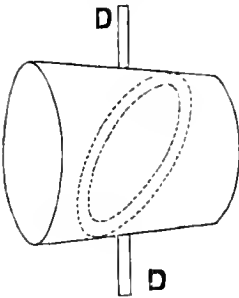

Fig. 40.



phragm that the light is strongest at the centre, and falls off at the edges instead of the illumination being everywhere equal.

For if DD be a diaphragm, it is evident that the pencil of rays that enter it at right angles will be much larger than the pencils that take an inclined position, as represented by the dotted rays. The diminution of light in the pencils from the sky, is rather an advantage than otherwise; but the contrary is the case with the pencils from the foreground.

Several ingenious contrivances have been made to counteract this tendency. Thus a conical piece is arranged to set in the opening of the diaphragm DD , within it is an *inclined* diaphragm. This evidently allows a *larger* pencil to pass from the foreground than the centre,

and the pencil admitted from the sky is still smaller. With badly illuminated foregrounds this arrangement is advantageous, but in ordinary landscapes the distribution of light is found to be sufficiently good in the regular image.

CHAPTER IV.

FOCAL LENGTHS OF LENSES.

§ 1.—Images of External Objects.

IF an opening be made in a shutter A of a dark room, there will be formed on the opposite wall an image of external objects. The rays of light coming from an object BC will cross each other at the opening A ; will form an image ED on the opposite wall, which image will have the following characteristics:—

It will be reversed, because the rays cross at A , and that which was lowest (C) in the object, becomes uppermost (E) in the image.

If the opening A be small, the image will be very faint, but moderately sharp.

If the opening be large, the image will be better lighted, but will be confused.

There will be no focus. ED may be at any distance from A .

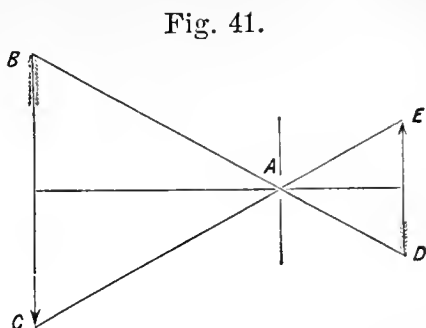

The fact that the confusion of the image can only be removed by an excessive diminution¹ of the opening, and consequent reduction of the light, renders it useless for photography. The cause of this confusion is shown in Fig. 42. Let P be any point

Fig. 42.

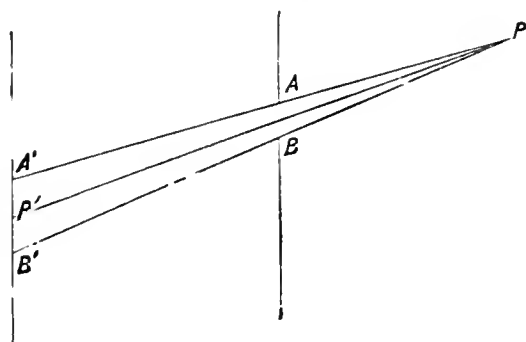

of any distant object, as the point C of the arrow in the preceding figure. The rays that emerge from it, after passing through the opening AB , are spread out upon the wall at $A'B'$, whereas they should be collected at the point P' .

This collecting of the rays and conveying them to the point P' is effected by placing a lens at the opening AB .

But now a new condition comes in with the lens. Without it images were formed though the wall were at any distance from the opening. But with the lens the surface that receives the image must be at a fixed distance from the lens. This distance is its focal length. Measured from the back surface of the lens, it is called the "back focus," an extremely rough and erroneous mode of measurement. Measured from the true point (the centre of emission, hereafter explained) it is the *absolute* focus, also called the principal focus or equivalent focus.

¹ With an excessive diminution of the opening, another difficulty presents itself, that of diffraction. The lines of light are bent by the edges of the opening.

Fig. 43.

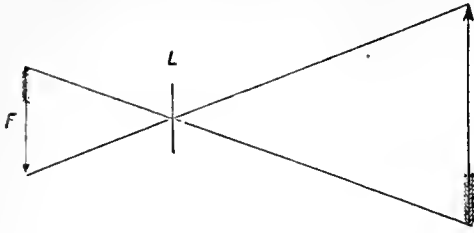

If rays from an external object fall upon the lens L , Fig. 43, and an image is formed at F , the focal length would be the distance from F to the lens at L , supposing the lens to have no thickness. But as all lenses have thickness, the question immediately arises, from what point or part of the lens or lenses is the measurement to be taken?

To answer this question it is necessary that we should get a clear idea of certain remarkable points belonging to lenses, single or compound.

§ 2.—Optical Centre.

All lenses have a remarkable point, to which the above name has been given. All lines that pass through the lens and also

Fig. 44.

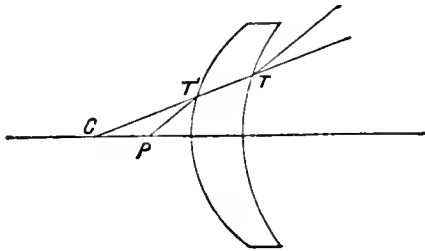

through this point, are termed *transversals*, and have the remarkable property that all rays which pass through the lens along their path, emerge from the lens parallel to the direction in which they entered it.

If C be the optic centre, any line CT passing through it will be a transversal. If now a ray of light strike the lens at T at such an angle that it follows the path TT' it will, on emerging at T' , follow the direction $T'P$ parallel to its original course.

The optical centre of any lens is easily found. It is only necessary to draw parallel radii from the two centres of curvature, to connect the points at which these radii meet the curves, and to prolong this line till it intersects the axis.

From the centre C of the one curve draw any radius CR . From the centre C' of the other curve draw another radius $C'R'$, parallel to the first. Connect the points RR' , prolonging, if necessary, the line of connection RR' , till it intersects the axis CC' . The point of intersection O will be the optical centre of the curve. In a double convex lens (Fig. 45) the optical centre falls inside the lens, in the meniscus (Fig. 46) outside of it. In a

Fig. 45.

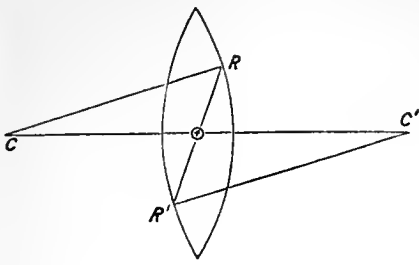
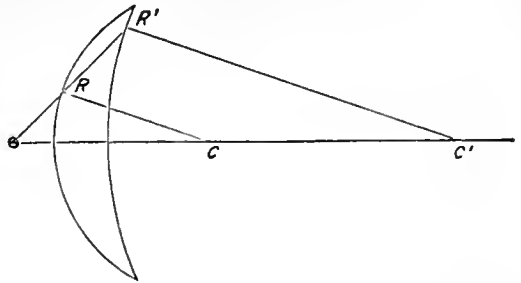

Fig. 46.



double convex lens, whose surfaces are of equal curvature, the optical centre will coincide with the centre of the lens.

§ 3.—Centres of Admission and Emission.

These centres play too important a part in photography to be here passed over.

Let O be the optical centre, as before, of a double convex lens; then any lines drawn through it, as $T T, T' T''$, are transversals, and any rays that strike the points $T T''$ at such angles of incidence as to follow the course of the transversals, will, as before explained, emerge at $T' T''$, on the other side of the lens, and follow paths parallel to their original direction.

Fig. 47.

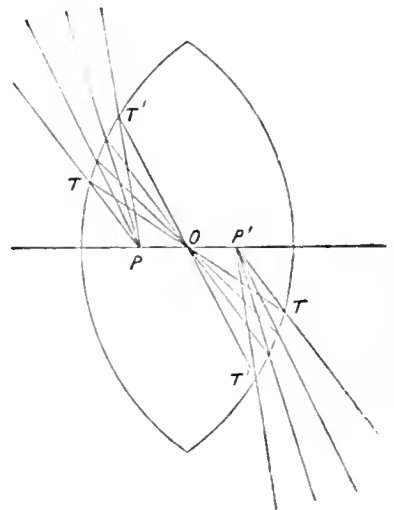

If, now, all the entering rays be prolonged in their original directions, they will converge to a point P on the axis of the lens. This is the *centre of admission*. If the emerging rays be likewise prolonged, they will meet at a point P' . This is the *centre of emission*.

This statement is rigorously true only for rays very nearly parallel with the axis, for others it is simply an approximation.

Now, if in Fig. 48 we have a bi-convex lens, and $A B$ be an object before it, $C D$ its image, the focal length of that lens must be measured from P , its centre of emission, that being the point to which all the rays, $C P, F P, D P$, converge. And similarly, if we wish to take

Fig. 48.

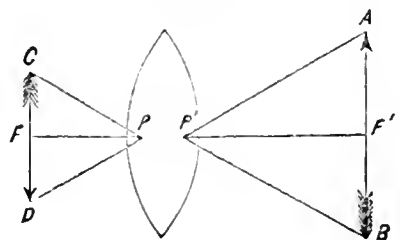

into account the distance of the object from the lens, it is to be computed neither from the exterior of the lens, nor from its centre, but from the centre of admission P' . Consequently, when we speak of the conjugate foci belonging to the lens for an object AB , and its image CD , these focal lengths are the lines $F'P'$, FP .

In the following figure of a meniscus lens, the transversals are seen centering at O , the optical centre of the lens. The respective

Fig. 49.

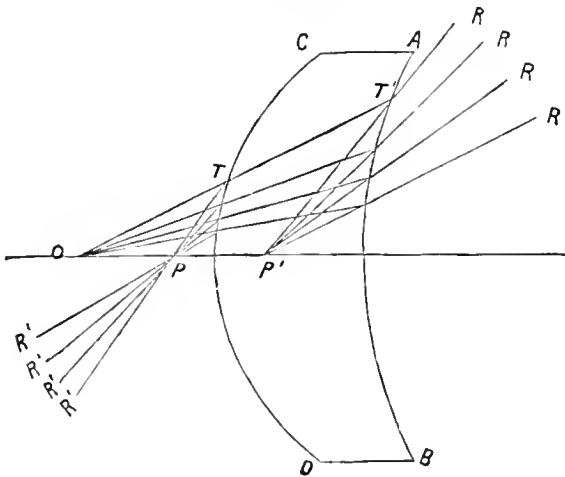

rays $R R R R$ are those that undergoing refraction at the surface AB , follow the courses of the transversals through the lens. Emerging they take directions $T' R'$, &c., parallel to those which they originally had, and all cut the axis at P , the centre of emission.

The focal distance of any object in front of this lens will therefore be measured to the centre of admission

P' . And the focal distance of any image will be measured from that image to the centre of emission P .

If the first surface of the lens AB be plane, the lens becomes a plano-convex, and the points O and P both recede to the intersection of the curve CD with the axis OP' , where they coincide.

§ 4.—To Determine Focal Lengths by Actual Measurement.

Equivalent Focus.—This term is constantly misapplied, and most of the popular explanations of it are erroneous. The whole matter is, however, very simple, and may be explained as follows:—

In a plano-convex with its plane side to the object, the focal length is the distance between the ground glass B' (Fig. 50) and the *back surface* of the lens, therefore $A'B'$. This distance is easy to measure, and offers a valuable aid towards determining the focal lengths of other forms of lens.

Suppose now that we have a doublet MN , OP , and that a very distant object is focussed correctly when the ground glass is in

the position C D. The question arises, are we to measure from the ground glass at B to what point? the back lens, the front lens, or what point between?

Let us suppose that we find a plano-convex lens R S, which, when placed in the same position as the doublet, and focussed on the same distant object, makes its image C' D' exactly the *same size* as the image C D of the same object given by the doublet. *Then these lenses have the same equivalent focus*, and the easily measured focal length A' B' of the plano-convex is also the true (equivalent or absolute) focal length of the doublet. The rays A C, A D, which form the image in the case of the doublet, diverge as if they came from a point A, which point is the centre of emission.

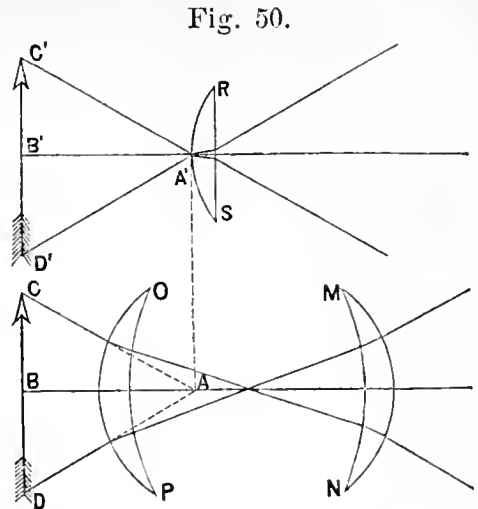

Fig. 50.

It follows from the foregoing that all lenses that have the same equivalent focus, will, when focussed on some distant object, produce images of it that have the same size, the one as the others.

And further, which is important, that lenses of different focal lengths will, when focussed on the same distant object, produce images of it whose size is proportionate to the respective focal lengths.

If A B, Fig. 51, be any distant object: different lenses placed at L will give images of it having different sizes, but these sizes will always be proportional to the focal length P' F', P' F', &c., and will be larger or smaller in the exact proportion of the focal length of the lens that forms them. A lens having twice the focal length of another, will, when placed in the same spot, and focussed upon

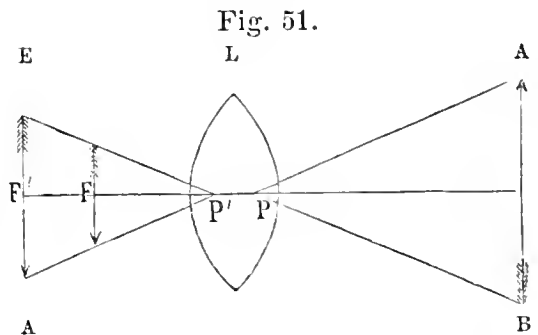

Fig. 51.

the same distant object, produce an image having twice the linear dimensions of the image given by the first. If, therefore, in order to find the focal length of a doublet, we compare it with a plano-convex as in Fig. 50, it is not essential that the two should give images of the same size, which might in practice

be difficult to attain. But having easily measured the focal length of the plano-convex, we simply compare the size of the two images, the proportion between which establishes the focal length of the doublet. If the image given by the doublet is one-fourth longer, we know that its focal length is necessarily one-fourth longer, and so on. And having thus determined the exact focal length of one doublet, we may use it (just as well as the plano-convex) to determine the focal length of any other description of lens, by the same system of comparing the linear dimensions of the image formed.

Another practical method of determining the focal length of any form of photographic objective has been indicated by Mr. Grubb.

Mark the centre of the focussing screen by drawing diagonals from opposite corners. Set the camera on a large sheet of white paper; place the camera so that the images of two well-marked distant points shall be equally distant, one on each side of the centre. Measure the distance of these two points from each other on the screen. Now turn the camera so that one of these points shall fall exactly upon the centre. Having done this, run a pencil along the side of the camera, ruling a line on the paper underneath. Now turn the camera around again, till the other point falls on the centre of the focussing screen, and draw another line on the paper.

Fig. 52.

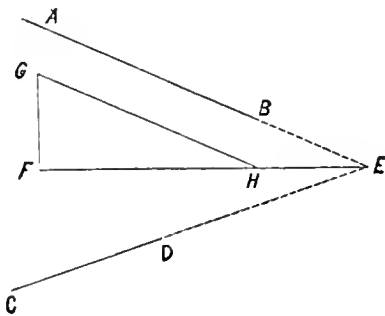

Let AB and CD be the lines so drawn; continue them till they meet at E . Bisect the angle AEC by the line EF . At any point F erect the perpendicular FG equal

to half the length of the space measured on the ground glass between the points. From G draw GH parallel to AB . The distance on FE of its intersection H from F will be the absolute focal length of the objective used.

This having been once correctly done for any one lens, it will serve as a standard for the easy determination of others by the method above described.¹

¹ Another method is the following: Focus two objects, so that their images will fall upon the ground glass equally distant from the centre, as before described; then measure with a theodolite the angle which these objects subtend.

It is remarkable that the method of determining the focal length of a lens by focussing an object so that the size of its image shall be equal to its own, and then taking one-fourth of the distance between the object and its image for the focal length, after having been repeatedly shown to be inaccurate, has been constantly brought forward again. The error lies in the misapplication of the formula $\frac{1}{f} = \frac{1}{v} + \frac{1}{u}$ by which it is attempted to afford a proof. This formula neglects the thickness of the lens, which, in compound lenses (*i. e.* doublets, &c), is often very considerable, and thereby introduces an error. Nor can this error be avoided by computing these focal distances from the optical centre of the lens, since they must be computed from the centres of admission and emission to render the formula applicable.¹

§ 5.—To Calculate the Focal Length of a Lens from its Dimensions.

In the following formulæ, it will be taken for granted that the lens is made of glass, having its refractive power equal to 1.5. The more general expressions will be given in foot-notes. The focus in all cases is determined for sunlight or parallel rays falling parallel with the axis of the lens.²

In the case of a *glass sphere* the focal length is $1\frac{1}{2}$ times the radius, measured from the centre of the sphere. It falls therefore beyond the sphere at the distance of half the radius from the surface.³

Calling this angle α , and d the distance measured on the ground glass, the focal length will be found by the expression—

$$f = \frac{d}{2 \tan \frac{\alpha}{2}}$$

¹ If it were required to make a correct determination by the method of focussing equal size, it would be necessary to determine for any lens the distance which separates its centres of admission and of emission. Calling this δ and the distance between object and image, D , we have $f = \frac{D \pm \delta}{4}$, the positive sign applies when the centres cross each other, the negative when they do not, as in the photographic objectives.

² These calculations are all based (except when otherwise specified) according to custom, and for simplicity, upon the supposition that the lens has no thickness.

³ The general expression is as follows: Let r equal index of refraction, R the radius, f the focal length, then $f = R \frac{r}{2(r-1)}$.

*Double Convex Lens.*¹—If the curves on both sides are equal, the focal length will be equal to the radius.

If unequal, multiply the radii together, and divide by half their sum. If the radii are respectively 5 and 7 inches, the focal length will be $\frac{35}{6}$ inches or $5\frac{5}{6}$ inches.

Plano-convex Lens.—Where the plane side is exposed, the focus will be twice the radius, measured from the convex side. Where the rays fall on the convex surface $\frac{2}{3}$ the thickness of the lens must be deducted from twice the radius, and this will be measured from the plane side.

Meniscus Lens.—Multiply the radii, and divide the result by half the distance of the radii. For example, if a meniscus has its positive curve with a radius of 5 and its negative 7 inches, its focal length will be $\frac{35}{\frac{1}{2}(7-5)}$, or 35 inches.

If the concave surface had a radius of 5 and the convex of 7, the focus would be the same, but it would be a *virtual focus*, an imaginary one in front of the lens.

Fig. 53.

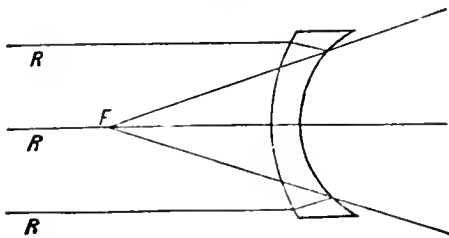

So in Fig. 53, the parallel rays *R R R* are spread out by the negative meniscus, so that if their direction were continued backwards, they would meet at *F*, the virtual focus.

Although this focus has only an imaginary existence, it becomes important in computing the effect of introducing a *negative lens*, as in several forms of photographic objectives.

§ 6.—Focal Lengths of Combined Lenses Computed from their Elements.

Where two lenses of known focal length are combined together, it is easy to determine the focal length of the combination. It becomes here necessary, however, to take into account the distance at which *the two lenses are separated*, as the focal length always increases as this separation increases.

¹ The general expression for the focal length of any lens in terms of its radii, is $\frac{2 R R'}{R \pm R'}$, the positive sign belonging to the biconvex lens, the negative to the meniscus.

Add the two focal lengths together, and subtract the distance of separation. Multiply the two focal lengths together, and divide this last quantity by the first, which gives the focal length.¹ This formula, which, like the preceding, depends on the supposition that glass with a refractive power of 1.5 forms the material of the lenses, is that which is employed by opticians in their calculations.

Two lenses of 6 and 10 inches focal length respectively, separated one inch, will have their combined focal length $\frac{6 \times 10}{16-1}$, or 4 inches.

If these lenses when combined are to have a focal length of 5 inches, this can be effected by giving them a separation of 4 inches, because $\frac{6 \times 10}{16-4}$ is 5 inches.

§ 7.—Conjugate Foci.

Up to the present point we have considered parallel rays only. But when divergent or convergent rays fall upon a lens, its focal length is thereby necessarily altered.

Thus the lens AB having its focus at F for parallel rays, may have it at D for diverging, and at E for converging rays.

Fig. 54.

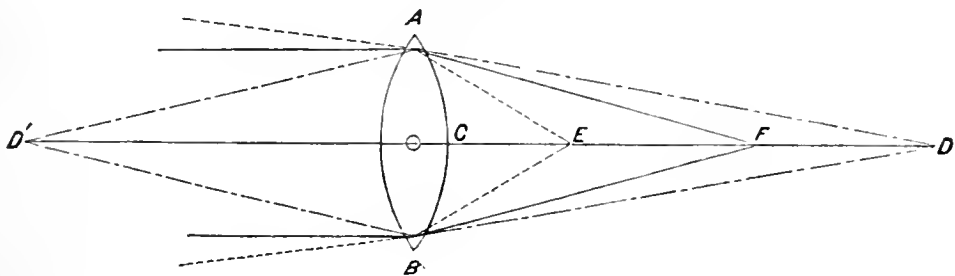

If D' be a point from which diverging rays emanate and these converge again after passing through the lens, at D , these two points D and D' , are termed conjugate foci. If D' be an object, it will have its focus at D . These points are interchangeable, so that if the object be placed at D , its focus will be at D' .

¹ If f and f' are the respective focal lengths, and d the distance of separation, then the combined focus will be $\frac{f \cdot f'}{f + f' - d}$.

Fig. 55.

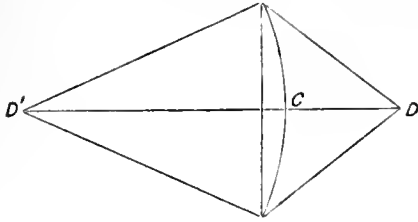

To observe this better, let us take a plano-convex lens, with its plane side to the object.

The object D' has its focus at D . If the principal focus (that for parallel rays) be called f , and the distance $D' C$, u and $C D$, v , then we shall have this relation:—

$$\frac{1}{f} = \frac{1}{u} + \frac{1}{v} \text{ or } v = \frac{fu}{u-f}$$

This equation will permit, if the principal focal length is known, to determine the position of the image D of any object situated at any point D' . If, for example, the lens have a focus of 6 inches, and the object D' is 10 feet or 120 inches off, we shall have—

$$v = \frac{6 \times 120}{120 - 6} = \frac{720}{114} = 6.315.$$

The focus of such a lens will, therefore, be a little over three-tenths of an inch longer for an object at the distance of ten feet, than for a very distant object, that is to say, for parallel rays.

It will be seen that this formula gives a very simple rule for calculating focal lengths. If the principal or absolute focal distance of a lens be known, and we place an object nearer to the lens, and require to know what will be the focal length of the lens for such an object, we have only to take these two quantities—the absolute focal length and the distance of the object. First multiply them and then subtract them, and divide the first number by the second, as in the example where 120 was multiplied by 6, and divided by 120 less 6.

It is a very important point, and one that has been too often overlooked in treating the subject elementarily, that the formula $\frac{1}{f} = \frac{1}{u} + \frac{1}{v}$ neglects the thickness of the lens. In practice it is necessary either to introduce a correction for this quantity,¹ or

¹ The most general form of expression for conjugate foci is

$$v = \frac{u \{ n r r' - (n-1) t r' \} + t r r'}{u \{ n(n-1)(r+r') - (n-1)^2 t \} + (n-1) t r - n r r'}$$

There t is the thickness of the lens, $r r'$ the radii, and n the index of refraction. —*Secretan, Systèmes Optiques Convergens*, 54.

else to consider the various focal lengths as measured from the centres of admission and emission already described (p. 69). In the case of a plano-convex lens, these centres fall together at the centre of the convex curve, and the focal lengths are correctly measured from the point O in the figure.

Although, exactly speaking, the focal length of the image always varies with its distance from the lens, yet there is practically a distance for each lens beyond which all objects are simultaneously in focus. If, for example, we say that a difference of focal length not exceeding $\frac{1}{50}$ of an inch may be neglected, then we may fix for every focal length of lens the distance beyond which all objects are practically at once in focus.

We had on the last page the formula $v = \frac{fu}{u-f}$. Now, if the limit of u is that it shall not be more than $\frac{1}{50}$ of an inch longer than the principal focus, put $u = f + \frac{1}{50}$, and we have

$$v = 50f^2 + f.$$

As f is inconsiderable in comparison with the other members of the equation, it may practically be neglected, and it may be said that all objects that are distant over fifty times the square of the focus, are simultaneously in focus.

Consequently:—

For lenses of	3	inches	focal length	the distance is	37½ feet.
“	“	6	“	“	150 “
“	“	8½	“	“	300 “
“	“	10	“	“	417 “
“	“	12	“	“	600 “
“	“	16	“	“	1065 “

Objects at these distances may be said to have practically the same focal length as those at any *greater* distance. To get objects at these distances into focus simultaneously with those at *less* distance, we must depend upon the “*depth of focus*” of the lens, a very precious quality possessed by different lenses in very various degrees.

When the image is formed by rays which meet at a very small angle, as at F , Fig. 37, it is evident that the focussing screen can be racked a little in or out without much injury to the definition, and thus a good uniform average focus is obtained.

CHAPTER V.

PHOTOGRAPHIC OBJECTIVES.

IN this chapter will be briefly considered the various forms of photographic objectives now chiefly used.

§ 1.—The View Lens.

By a view lens is understood a single achromatic combination, usually consisting of two pieces, forming a meniscus or a plano-convex lens, with the concave or plane face, as the case may be, turned to the light. This form of lens is figured at page 61, Figs. 30, 31, 32. The combination of a double convex of crown and a double concave of flint glass is the usual method employed.

Latterly Dallmeyer has produced a wide angle view lens, constructed of three pieces, as shown in the margin (Fig. 56).

A flint negative meniscus is inclosed between two menisci of crown glass. In these two latter the crown glass is not of equal refractive power, the rear lens having a somewhat less index of refraction than the front.

In this way a most excellent lens is formed. It has, of course, the fault common to all lenses not centrally stopped, that straight lines are more or less curved on the image. It is therefore only suited for landscapes in which architectural subjects are not inserted, or where these are small and inconspicuous. But for all

cases in which it can be properly used, and these are very numerous, the writer thinks very highly of it. If this lens be critically compared with the Steinheil aplanatic, it will be found that, in respect of that very important quality, depth of focus, the wide angle view lens has a distinct advantage. It also covers satisfac-

Fig. 56.

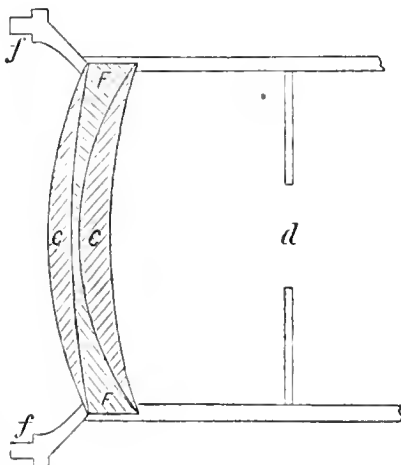

FF. Flint negative meniscus.
c c. Two positive menisci of crown glass.
d. Diaphragm.

torily a wider angle. Thus the $8\frac{1}{2}$ wide angle covers a $6\frac{1}{2} \times 8\frac{1}{2}$ plate, whereas with the aplanatic the $9\frac{1}{4}$ -inch is required. It is true that the seven-inch is sold for this purpose, which, however, it does not properly accomplish. The $9\frac{1}{4}$ -inch Steinheil used on a $6\frac{1}{2} \times 8\frac{1}{2}$ plate gives, of course, a rather less angle of view than the $8\frac{1}{2}$ view lens, but, on the other hand, gives a better marginal definition and straight lines.

The wide angle view lenses more than cover the plates for which they are advertised, and admit of a little pushing up or down of the camera front, without producing black corners. The writer has not found any more serviceable lens for view-making.

§ 2.—The Portrait Lens.

The form of objective represented at Fig. 57 is that at the present time exclusively used for portraiture. It was the result of

Fig. 57.

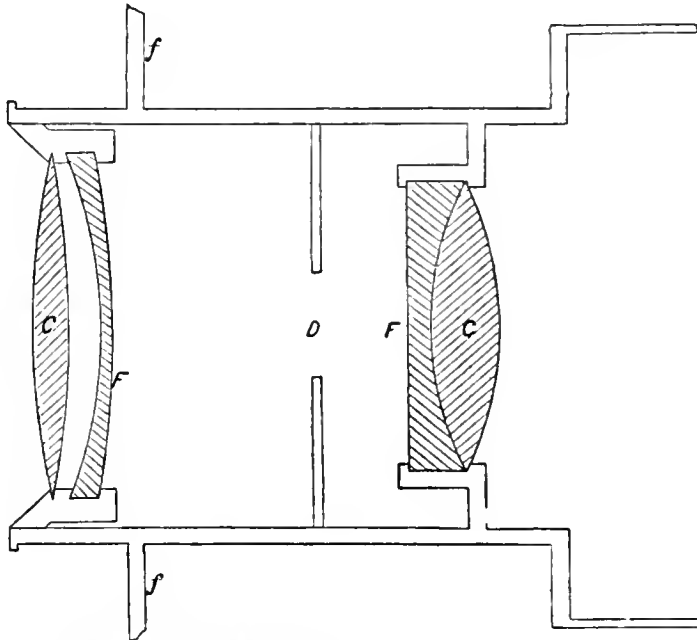

- C, C.* Double convex crown glass lenses.
F, F. Negative flint lenses; the front, plano-concave, the back, negative meniscus.
f, f. Flange.
D. Diaphragm.

the labors of Petzval, of Vienna, who calculated this combination, and by its immense improvement over the systems previously in use for portraiture gave a vast impetus to that branch of photographic art. A glance at the figure will at once explain the nature of the arrangement.

As the portrait is most natural and effective when the sitter

has not been compelled for a length of time to retain his position, and as the chances of moving are greatly increased with the length of the exposure, the great object of the portrait combination is to throw as strong a body of light into the camera as possible. Considerations of depth of focus, correction for spherical aberration, &c., have been necessarily, to some extent, subordinated to the one great need.

It follows that, instead of having many planes in excellent focus simultaneously, as in the case of the view lens, the portrait lens is very restricted in this respect, and hence cannot be appropriately used except for the purpose for which it is intended.

Some portrait lenses, especially the Jamin (Darlot) lenses, are arranged to permit of the front portion, consisting of the double convex and plano-concave, to be unscrewed, and after reversing, be screwed into the same flange for use as a view lens. This is a very convenient system; it is, however, liable to the objection that the front surface of the view lens thus made is plane, instead of concave. Now, to get the best results, not only the front surface should be concave, but this concavity should be considerable. Such a view lens cannot, therefore, be expected to give strictly first-rate results, though it may do good work. It cannot be too clearly understood by the student, that the whole system of photographic objectives is a system of compromises between conflicting troubles; that these compromises can always be best adjusted for some definite end, and that consequently when one sort of objective is made to do another's work, such work is always done at a disadvantage.

Mr. Dallmeyer gives the following information relative to the character of portrait lens best suited for given sizes of plates, supposing the camera to be placed at a distance of 18 to 20 feet from the sitter, as he advises.

The *equivalent* focal length of the lens for a given sized plate should be about double its largest side; that is for card size, $4\frac{1}{4} \times 3\frac{1}{4}$, the focal length should be 8 to 9 inches; for cabinet size, 6×5 , 12 inches; for 8×10 plates, 20 inches. Salomon's success confirms these views; his 8×10 plates are made with a lens of 20 inch focus.

Next arises the question as to what diameters these lenses should have. It is useless to expect that the highest degrees of rapidity, flatness of field, and depth of focus can be combined,

because these qualities are essentially antagonistic. So that two lenses, both perfectly corrected for spherical aberration, and of the same focus, the one of two inches diameter, will have double the depth of focus of the other, whilst the latter, on the other hand, is four times more rapid.

Or again, comparing two lenses, both having the same ratio of diameter to focal length, consequently of equal (or nearly equal) rapidity, the greater the length of focus the less the "depth" of focus. Thus, for example, a card lens of 9 inches equivalent focus and $2\frac{3}{4}$ diameter, producing a card picture at 20 feet, will sufficiently define accessories at eighteen inches in front of, and behind the principal object having thus a "depth" of 3 feet, whereas a lens of twice the focal length *placed at the same distance of 20 feet*, will have but half the "depth," viz., 9 inches before and behind the object, but will produce an image four times, *i.e.* twice linear, the size.

These lenses were first manufactured by the well-known firm of the Voigtlanders. Now they are made by opticians generally.

§ 3.—Steinheil's "Aplanatic" and Dallmeyer's "Rapid Rectilinear."

Several years ago two lenses were invented, the one in England, the other in Germany, which are remarkable in their performances, and in a certain similarity to each other.

Fig. 58.

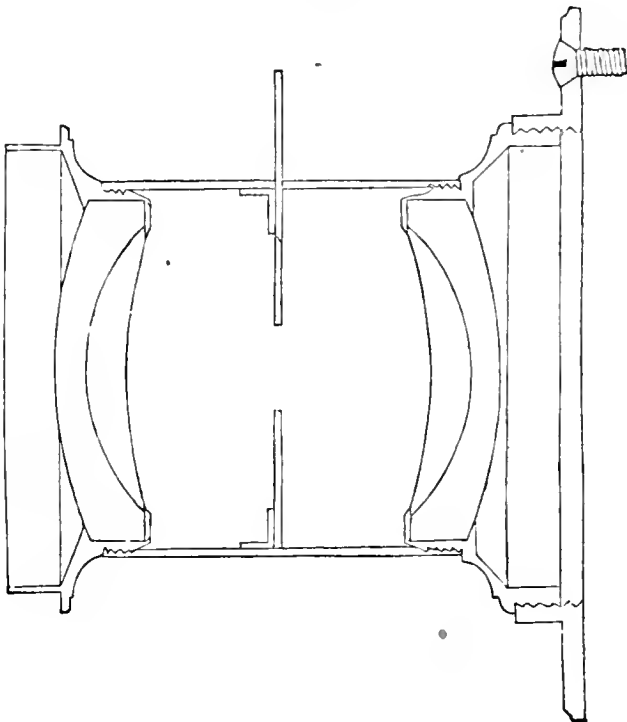

Steinheil's aplanatic, of which a figure is given below, for which the writer is indebted to Dr. Liesegang's *Archiv*, has already become a great favorite in this country. It is a "symmetrical doublet," that is, the front and back lenses are alike. Each consists wholly of flint glass, but the respective portions being composed of flint glass of different refractive powers, correct each other, so that the lenses are achromatized; in this is an essential difference from any other lens hitherto constructed.

It is an advantage in the Steinheil lens that when used with a large diaphragm, although the exterior portions of the image lose their sharpness, the central portions are still tolerably good. As the rapidity of a lens increases greatly with the increase of the diaphragm, we may thus employ the aplanatic as a portrait lens, if we reject all but the central portions. It does not, however, in this way attain the rapidity of a good portrait lens. For *groups*, it and the Dallmeyer rapid rectilinear are probably the best of all lenses.

The Dallmeyer rapid rectilinear greatly resembles the Steinheil aplanatic in its form. Its symmetrical lenses are not, however, made of flint glass only, but of flint and crown achromatized in the usual manner. Although less known in this country, they are equal to the Steinheil; indeed, there is, as far as the writer's experience goes, no choice between them.

One important point in the comparison should be noted. Similar as these lenses are, their makers have taken different views as to their powers, and the Steinheil lenses are advertised to cover a plate one size larger than the Dallmeyer. Thus the Steinheil having about 9 inches focal length, is advertised for use for 8×10 plates, whilst the corresponding lens of Dallmeyer is advertised for $6\frac{1}{2} \times 8\frac{1}{2}$ plates. This might naturally lead to misconception, in the supposition that the lenses covered different angles and had different powers. The fact is that the nine inch lens will with a little straining cover (in either case) an 8×10 plate, and may be used with it, but generally will be found best suited for a $6\frac{1}{2} \times 8\frac{1}{2}$. In other words, the nine inch focus lens, when worked with a fair-sized stop, has hardly power enough for the 8×10 , and rather more than power enough for the $6\frac{1}{2} \times 8\frac{1}{2}$.

These lenses fall off a good deal in illumination towards the edges. At the centre, the definition cannot, in the writer's opinion

be easily surpassed, but as we pass from the centre, it rapidly falls off, unless sharply stopped down.

For architectural work both these lenses have no superiors, and the same may be said as to groups. They are useful for instantaneous work, though not so rapid as a first-class portrait lens, and the same is true of portraiture. For copying they are excellent. When width of angle of view is important, they are exceeded by several lenses, by Zentmayer's lens, by Dallmeyer's wide-angle rectilinear, by Steinheil's pantoscope, &c.

Steinheil's Uncorrected Lens.—Previous to the discovery of the lens above described, Prof. Steinheil devised a lens consisting of two uncorrected menisci, which were remarkable for the great size of plate covered by so small a lens. The adjoining figure gives an idea of its construction. It is now superseded by his achromatized doublet or *aplanatic*.

Fig. 59.

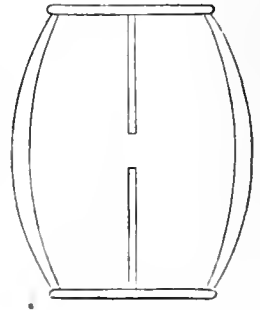

A useful maxim, familiar to experienced photographers, is *never to strain a lens*. Some who purchase a lens intended to cover a given size of plate, and who find that by using a very small stop, good definition can be got over a materially larger plate than that for which the lens was advertised, think they have made a useful discovery, and perhaps avail themselves of it habitually. The work so produced will never have the boldness, atmospheric effect, gradation of distance, and transparency of shadow given by a lens used with a larger opening.

On the other hand, it is a mistake to use a lens intended for larger views, in taking small ones. Lenses for large views are unavoidably slower, and the extent of angle included in a small view, taken by a longer focus lens, is too small. An exception to this is when a lens, like the triplet, is used for instantaneous effect, and where it is worked with a large stop, rejecting all but the centre of the image.

§ 4.—The Triplet.

The triplet lens consists of two large achromatized menisci, between which is placed a small negative lens as near as possible

to the diaphragm. The length of the focus is thereby increased, but at the same time marginal definition is obtained.

The triplet is a lens which, although possessing great merits, has been somewhat over-praised. It is a useful lens undoubt-

Fig. 60.

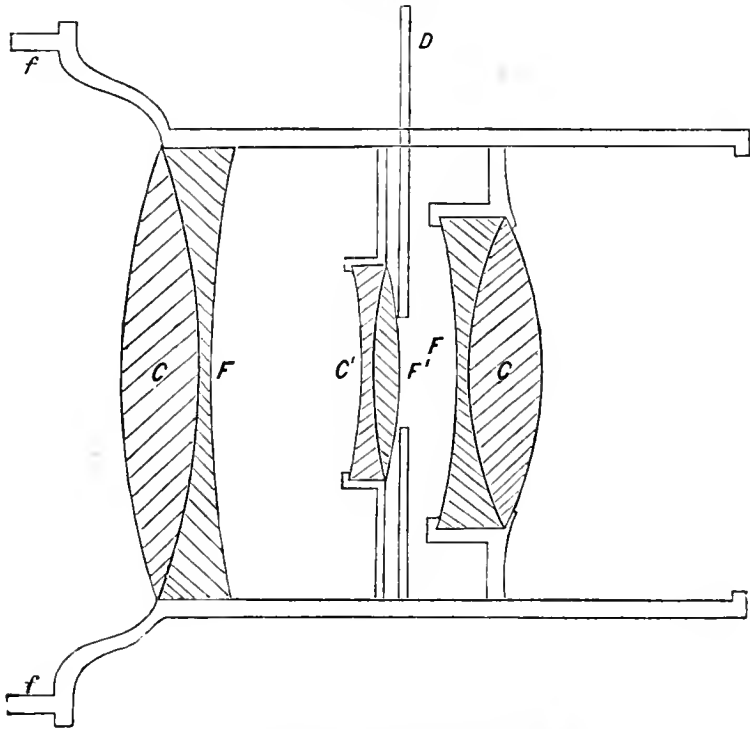

- C, C.* Double convex crown glass lenses.
F, F. Double concave flint.
C'. Double concave crown.
F'. Double convex flint.
D. Diaphragm with its opening at *F'*.
f, f. Flange.

edly, but since critically examining its power, the writer finds himself led to the following comparison:—

For architectural objects it is surpassed by the Steinheil, the Dallmeyer rapid rectilinear, and by Zentmayer's lens, the last mentioned of which gives lines equally straight, and includes a very much larger angle. Where angle is no object, where we have free open space in the desired direction about the architectural object, there only the triplet may be conveniently employed.

For copying, it is surpassed by the same lens.

For views not embracing architectural objects, or where these are not near the margin, and are inconspicuous, it is undoubtedly surpassed by the view lens, especially by Dallmeyer's wide angle view lens.

For portraiture, it is inferior to the portrait lens, being much slower. By removing the central negative lens, however, its action is increased; but the centre of the image only is sharp enough for use, as in the case of portraits to be vignetted.

§ 5.—The Globe Lens.

The globe form of lens was devised in this country by Mr. Schnitzer, and was manufactured by him in connection with the late Mr. Harrison. Its characteristic feature lies in this, that the exterior curves, back and front, form part of one and the same sphere, the diaphragm being placed at the centre of that sphere. Consequently it follows that the incident ray *R*, Fig. 62, which passes through the centre, has a *nearly* perpendicular incidence upon the outside surface. It therefore undergoes but little deviation at either of the four surfaces, but necessarily encounters some, and is bent from its original direction *R P* down to *D*. A grave objection to this lens lies in its tendency to form a

Fig. 61.

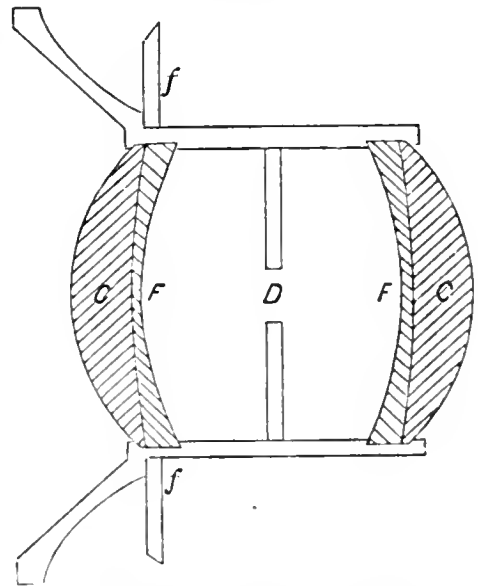

C, C. Positive menisci of crown glass.
F, F. Negative menisci of flint glass.
D. Diaphragm.
f, f. Flange.

Fig. 62.

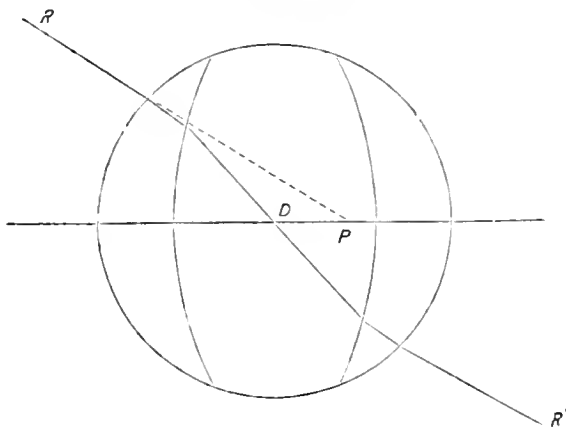

thicker spot at the centre of the image, called *flare*, or *ghost*, the cause of which will be explained further on (see p. 91).

§ 6.—The Zentmayer Lens.

Mr. Joseph Zentmayer, of this city, has succeeded in making a photographic objective of a single sort of glass, his lenses being both uncorrected menisci. Nevertheless, in these objectives the chemical and visual foci are practically coincident. This single fact would be enough to invest the lens with interest, but its performances are sufficiently remarkable to indicate that this

lens will be adopted for all those descriptions of work to which it is especially suited.

Fig. 63.

D. Diaphragm. *f, f*. Flange.

Fig. 63 will give a clear idea of the system of construction. The front and back curves of each lens stand to each other in the relation of 12 to 13, and the two lenses to each other in the ratio of 2 to 3. The stop is advanced a little nearer to the front lens than the centre of curvature of the exterior surface of the larger lens.

It is evident that by having a series of lenses of different sizes, the larger lens of one pair may serve as the smaller lens for the next larger pair. On this principle these lenses are manufactured. The complete sets embrace six lenses, capable of forming five pairs, having a great range of focal lengths. Smaller sets are made, in which four lenses form three pairs.

These lenses include a wonderful angle—fully as much as can ever be advantageously used, and much more than covered by the globe lens. The architectural effects attained are good, and bolder than would be expected from the small size of the stop that must be used. The reflecting surfaces which the ray meets in this lens are fewer than in any other centrally stopped objective, and this gives brilliancy as well as diminishes the proportion of light lost. For copying these lenses are at least as good as any. They are, in the opinion of the writer, unsuitable for landscape work, by reason of the small stop required.

§ 7—Ross's Doublet.

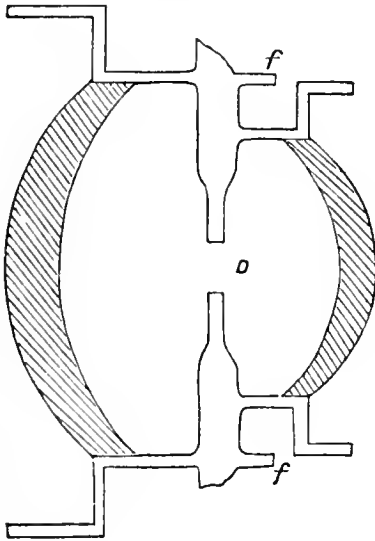
Mr. Ross's form of doublet, Fig. 64, has been favorably spoken of. It is intended for views and architecture, of which last it preserves the straight lines, and for copying. A material convenience is afforded with this lens, an internal shutter, sliding across the opening of the diaphragm, instead of covering and uncovering the lens in the usual way with a cap. This feature has been also introduced into Zentmayer's lenses.

Ross's lenses may be separated, and each can be used as a single landscape lens.

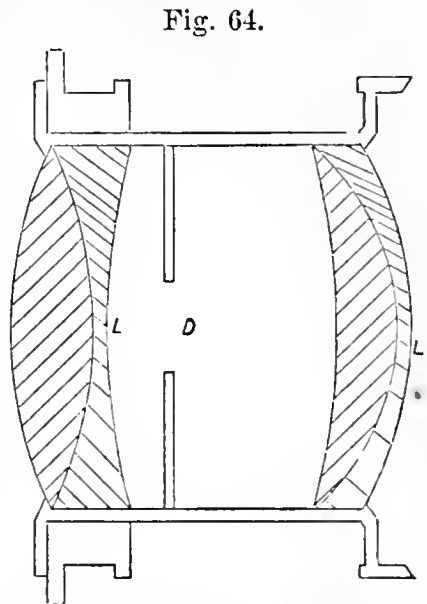

L, L. Positive menisci, corrected.
D. Diaphragm.

§ 8.—Other Forms of Photographic Lenses.

Orthoscopic Lens.—This form which, like the portrait lens, we owe to Petzval, has been extensively used, especially in this country. Harrison manufactured many good objectives of this form; but on introducing the globe lens, he stopped making the orthoscopic, and this lens is now but little used here. In Germany it seems to have kept its place better.

The orthoscopic is an excellent copying lens, but slow, owing to its long focus, and the small stop generally used with it in copying. For taking views, a stop of considerable size may be employed; and, as it has a considerable depth of focus, it is by some much prized for landscape work; though this is rather in Germany than here. Small pictures of landscape scenery are well taken by the smaller orthoscopic lenses, because in them the focal length is not far from corresponding with that of the eye. But large pictures made with the orthoscopic require a lens of very long focus; and it results that planes of distance are not well rendered, the foregrounds become indistinct and inconspicuous, and distant objects look unnaturally near. The remarkable influence exerted by the focal length of a lens upon the resulting image will be fully explained a few pages further on.

Busch's Pantoscope consists of two corrected lenses with a central stop. It includes a very large angle of view, and has been highly spoken of. A very carefully constructed camera appears to be necessary for it.

Blunt's Hemispherical Lens.—Mr. Blunt, of New York, constructs a lens of this name, which is spoken of in very high terms by Mr. Hull and other competent judges. Mr. Hull affirms it to be equal to any other lens for landscape purposes, without exception. It is also suited for architecture and for copying,

Dallmeyer's Rectilinear.—This lens is less rapid than the "Rapid" and the Steinheil aplanatic, but covers a very large angle, about 100° . It gives straight lines.

Panoramic Cameras.—The theory of this very ingenious instrument, by which such beautiful results have been obtained, is as follows:—

Let J be the centre of emission of the cone of rays coming out from any objective, single, double, or triple, which finds its focus on the screen SS' .

Fig. 65.

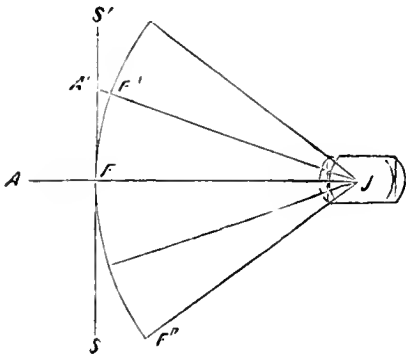

If now the lens be made to rotate horizontally, on J as a centre, the position of objects in the image formed on the focussing screen *will not change*. If the image of any exterior object, for example, falls at the centre F , the rotation of the lens will not cause the image of that

body to move, but it will remain accurately at F until the lens rotates so much that it passes out of the field of view.

Now, to avail ourselves of this property, we must remember that when the lens is rotated so that its axis passes from the direction JA to the direction JA' , its image is no longer in focus on the screen at A' , but at the point F' ; because the central ray is now in the direction JA , and its focal length will be the same it originally was, viz., JF or JF' .

The first idea for applying these principles would evidently be to use a sensitive plate of a cylindrical form, corresponding with the curve $F''F'F$, and by means of a mask with a vertical slit, to conceal all the plate but a high narrow strip at the centre; then if the plate $F''F'F$ remained stationary, and the lens rotated

carrying the mask with it, every part of the plate would be exposed successively.

But in the instrument now in use, this is otherwise managed. The sensitive plate occupies the position SS' , and is flat. It is masked, with a narrow opening at F , extending from top to bottom. As the lens rotates, the plate SS' is shifted sideways by a system of clockwork, which makes its movement exactly correspond with that of the lens, whether it be slow or fast, as the light may require.

As a curved plate, $F'F''$ would receive a perfect image from the rotating lens, masked as above explained, all that is necessary is that the flat plate SS' should be shifted in such a way that when, for instance, the lens has moved so that its axis is in the direction JF'' , then the plate shall have been brought up to F'' , there to receive its image at its correct focus. And, evidently, if the plate be long enough, and the camera be rotated to a full circle, an entire panorama may be obtained.

This picture will be found to differ materially from one obtained in the ordinary camera. It will be in panoramic, instead of plane projection. The picture will not be an harmonious whole, which the eye sees whilst regarding its perspective centre, but as if the eye were directed always opposite to it, in whatever direction it chanced to look, or, to speak more exactly, as if the eyes were directed in succession at all the vertical lines in the picture.

Another difference will be, that from end to end (but not from top to bottom) the picture, no matter how large, will be in equally good focus. At the right and left extremities the picture will be as sharp as the middle. This is because the central part of the image only is used. Each part becomes successively the centre.

Again, the vertical slit at F may be made narrow at bottom and wide at top, so that the foreground will get a larger exposure than the sky; and this difference may be regulated at will, giving, if desired, to the sky an exposure of one-tenth or less than that which the foreground receives. It is this which has enabled Braun to produce such wonderful cloud pictures in his Swiss scenery, and to get good definition of snow mountains against the sky and clouds.

The most successful application of this principle is at present Johnson's panoramic camera. It is patented, but the patent cannot cover the principle, which was understood many years before

his application of it, and was applied to the construction of panoramic cameras.¹

§ 9.—General Remarks on Lenses.

Portraiture.—The portrait lens is so far superior to all others for this purpose that none other is habitually used. The Steinheil aplanatic is the form that comes nearest in efficiency; it is now occasionally used for portraits, and is probably unsurpassed for taking groups.

For card portraits the focal length needed for the lens will depend upon how much is to be included. For full lengths, very short focus lenses are commonly employed. For such as show part of the body, and even including the hands, lenses of six to eight or nine inches focal length will be proper. For "cabinet size" lenses of eight to twelve inches focal length will be needed. For $6\frac{1}{2} \times 8\frac{1}{2}$ plates and half-length portraits, a lens of from ten to sixteen inches will be suitable. For very short exposures, especially in taking children, "extra rapid" lenses are made, with very short focal lengths. Some makers make a difference in their lenses according as they are wanted for full lengths and for vignetted heads. In the latter case every effort is made for perfect definition at the centre; in the former a good definition all over the plate is aimed at.

Generally, the shorter the focal length, the less exposure will be needed, and the facility of getting all portions of the image into focus will be greater; but the longer the focal length, the less exaggeration there will be in those parts that project, the hands especially.

Very ingenious arrangements have been adapted to the portrait lens, with the object of changing the focus during exposure, in the effort to get a diffusion of focus, and, instead of having one part sharp to the exclusion of the rest, to maintain a certain average of sharpness over the whole. Even lenses have been made in which a certain amount of spherical aberration has been left uncorrected, in order to diffuse the sharpness. The late Mr. Claudet brought this whole matter prominently forward shortly before his death, and opinions are very much divided on the subject.

¹ See *Secretan, De la distance focale des Systèmes Optiques convergents*. Paris, 1855.

Landscapes.—As already said, for such cases where it is applicable, the single view lens, especially the wide-angle form, is exceedingly satisfactory. The small angle included by the common view lens is often a great objection. The rapid rectilinear of Dallmeyer, and the aplanatic of Steinheil, are exceedingly useful in landscape work, are quick, clean, free from flare, and cover a very satisfactory and sufficient angle. Between the two there is little choice. In using the aplanatic, the photographer is advised to employ a lens of *one size larger* than that advertised for the size of plate which he has in view. With the other this is not necessary.

There seems to exist a curious distinction between the effects of these forms of lenses which has been little noticed. The wide angle view lens produces a remarkable amount of detail—every stone in a wall, every pebble on a shore, seem individually brought out, distinct from the rest. The aplanatic gives less of this individualization, but perhaps more general harmony. These effects have nothing to do with the sharpness of the image, for the distinction exists with lenses of equal focal length, equally stopped down, and producing equally sharp definition. If any difference exists, the image of the aplanatic is the sharper of the two, at the centre. In depth of focus the view lens has the advantage.

Flare or ghost in the camera is an indistinct image of the diaphragm. Let C be the centre of curvature of the second surface

Fig. 66.

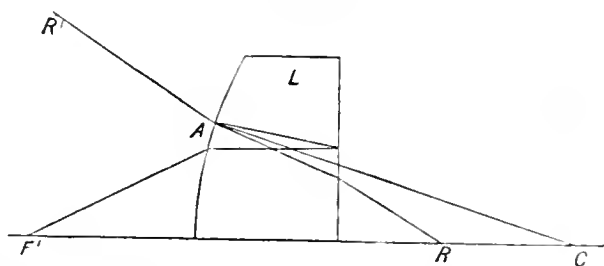

of the lens, whose thickness is here intentionally exaggerated, in order to make the lines visibly distinct. A ray R , passing through the diaphragm, strikes the first surface, is refracted, and passes to the second at A . Here it is divided—most passing onwards in a direction R' to form the true image, but a part suffering reflection and returning to the first surface. Here most is transmitted, but a part is reflected again and returns to the second surface. Here again the greater part is transmitted, after passing three

times through the thickness of the lens, and, undergoing refraction, is bent down to the axis at some point F' , producing the flare.

Comparing Lenses.—A great deal of unintentional injustice is done by photographers in comparing lenses, for want of taking the necessary precautions to make the test a just one.

It should invariably be borne in mind that *the performance of a lens depends entirely upon its stopping down*. Of two lenses compared, the inferior one may easily be made to seem the better, if it be used with a smaller stop, and no account be taken of the time of exposure.

It may be taken for granted that the sharpness, depth of focus, and size of good picture obtained will always increase as the size of the stop is diminished. This has led many landscapists to the use of extremely small stops habitually, esteeming it of little consequence to wait longer for the impression to be made. Several evils result from this practice.

1. It may be taken as an invariable rule that the larger the stop used, the more detail in the shadows will be obtained, always supposing that each trial has been made with a correctly timed exposure. Let us say that, with a half-inch stop, fifteen seconds have been found exactly right. Now, using a quarter-inch stop, we must expose for one minute or rather more.¹ The exposure will be correct; the picture will be the best obtainable with that size of stop, but the detail in the shadows will not be so good as in the former case.

2. A large stop gives a bolder picture and spaces it out better. The planes of distance are better made out. A small stop tends to produce a map-like effect. One-thirtieth of an inch is about the limit for the diameter of the stop for landscape work, and one twenty-fifth is much better, and ought to be generally used. That is, if the lens have a 10-inch focus, the stop should not be less than $\frac{2}{5}$ inch, or at farthest not less than $\frac{1}{3}$ inch. A small stop tends to produce pictures destitute of atmosphere, the distant objects look too near.

3. A long exposure in the case of portraiture is a serious evil. Even with landscapes it is not unimportant, for, although the

¹ Theoretically the exposure should always be inversely proportioned to the *area* of the stop, and this area is proportional to the square of the diameter of the stop. But in practice, it is found that the increase of exposure must be considerably more than in this proportion.

contrary has been affirmed, the difficulty of catching foliage still always increases with the length of the exposure.

The comparison, therefore, between lenses of *equal focal length* must always be made with stops of equal opening. Between lenses of *different focal lengths* no true or just comparison can be made at all. Some approximation may be reached by trying them with stops whose diameter is exactly proportionate to the focal length, but even then, the smaller lens will always work the quickest and otherwise appear to be the best. The truth is that the difficulties both of the optician in making, and of the photographer in using, increase so rapidly with the size of the picture, that between different sizes a just comparison is all but impossible. A photographer who has for a long time worked with any one size of plate, and then changes to a larger size and corresponding lens, becomes at once aware of the increased difficulties in his way. He must exclude more foreground, or he cannot get his whole picture well in focus. He must use a smaller stop also to the same end. His image on the ground glass is not nearly so brilliant, and his exposures must be materially prolonged to get a harmonious negative.

Selection of Lenses.—The *color* of a lens is always important. Place the lens on a perfectly white sheet of paper—any brownness of tint is a serious objection. In an old lens this may arise from the Canada Balsam, with which the separate portions are cemented together, turning yellow. If this be thought to be the case, the lens should be taken to an optician to be separated, cleaned, and re-attached. The photographer is not advised to attempt this himself.

Bubbles in the glass are objectionable, because they tend to throw rays in abnormal directions, and to impair the brilliancy of the image. One or two small ones are not important, nor a sufficient cause for rejecting an otherwise satisfactory lens. But it indicates carelessness in the maker, as these bubbles are always visible in the disk from which the lens is made, and such disks should be rejected.

Striæ, hair-like or thready transparent lines, are very objectionable, and at once a sufficient cause for rejection.

Scratches.—Lenses will sometimes come from the maker with scratches, the result of careless handling of tools in setting, or of bad packing. Such of course are returned.

Centering.—To every lens there belongs an optical axis, a line

perpendicular to the surface of the lens, and passing through its centre of curvature. Every achromatized lens consists of at least two portions, and it is necessary that these should be so arranged when attached together by the balsam used for that purpose, that the optical axis of each should exactly correspond. When two lenses or more are united to form an objective, not only must the parts of each be properly disposed, but the front lens must have its axis coincident with that of the back lens. This will depend upon correct mounting.

The usual way in which opticians test the correctness of the centering, is by making the tube containing the lenses revolve in an upright position, that is, with the lenses horizontal. If, now, a candle be placed at a little distance, and the eye be placed at a convenient position, the candle will be seen reflected from the surface as a bright point. Every surface of every piece of glass in the tube will send back a reflection. Next the tube is caused to rotate. Each lens that is correctly centered will continue to send its reflection back perfectly fixed and immovable; but any surface that is out of centre will cause its reflection to deviate more or less, according to the amount of error. It is evidently not necessary that all the reflections should be seen at once, but they may be observed successively. This method of observing evidently renders it easy to fix which, if any, of the surfaces is erroneously placed, and in which direction is its error.

Another mode of observation is more convenient for the photographer, as not requiring the apparatus needed for the method just described.

The observer places himself in a dark room with a single candle. Standing five or six feet from it, he looks at it through the objective, inclining the latter a little until he sees a series of bright points, which are the images of the candle, produced by successive reflections from the different surfaces of the lens. When a lens has four pieces of glass in its construction, as in the case of the portrait, globe, orthoscopic, and some other lenses, the number of possible images is very considerable. These cannot generally be all found at once, but eight, ten, or more can be counted; a little practice, and altering the inclination of the lens materially aids in increasing the number.

If now the centering is perfect, it will be found that, by carefully adjusting the position of the lens, all of these reflections can be made to range themselves in a straight line. But if any

one or more of the component parts is out of centre, this will be found impracticable. One or more of the bright points will remain obstinately out of line; and, when a little movement is made which brings them in, it will be found that some other image, previously in line, has slid out of it. When the observer, after very careful trial, finds that it is positively impossible to make all the images range, he will be justified in concluding that there is a fault in the centering.

Whilst this test is so easy that any intelligent observer can apply it at once, there is no doubt that it is a very severe one. A lens may perform quite fairly, and yet such an examination as this may reveal a defect. But there is no doubt that first-rate excellence is incompatible with such defectiveness.

It is also evident that the fewer the pieces of which a lens is composed, the less difficulty the optician will find in getting them all in correct line.

Quickness.—When lenses of equal focal lengths are tested with equal stops, their comparative quickness will depend upon the whiteness of the glass, the fewer number of surfaces that enter into their formation, and on the curves given by the optician: careful testing, and this alone, can settle the point.

Chemical Focus.—The correction for chromatic aberration is now greatly better made than formerly. To test whether a lens is properly corrected, select a newspaper printed with sharp-cut type, and paste a piece a foot or fifteen inches square upon a smooth piece of board. Set this up before the camera, with the columns vertical, but inclined in a slanting direction, so that one side, the right, for example, shall be a couple of inches nearer the camera than the left, keeping the board, however, exactly upright. Focus carefully along the central upright line, and copy it full size, or thereabouts.

Next examine the hair-strokes of the letters on the negative with a microscope. If the lens is properly corrected, the central line should be in the sharpest focus. If, however, it be found that a portion to the right or left of the central line is in better focus than the centre, then the correction has evidently been faulty. If the sharpest image is of a part *nearer* to the lens than the centre, the lens is *under-corrected*; if of a part further from the centre, the lens is *over-corrected*. In either case, it is said to have a "*chemical focus*," that is, its chemical and visual focus

does not correspond, a fault of the first magnitude, and sufficient cause for rejecting the lens entirely.

Flanges.—The flange is the brass circle, which is permanently attached to the camera front, and into which the lenses screw. It is greatly to be desired that opticians should adopt a regular set of sizes and threads for flanges, so that all the lenses habitually used with one camera should screw into one flange, and thus one camera front only be necessary. This has long been done in the case of microscopic objectives, which, no matter where made, screw at once into any instrument, though the latter have been made thousands of miles away. A similar system is greatly needed in photographic objectives. Dallmeyer has made some approximation to it, his lenses of different sorts all screw into the same flange, except where the lenses are of widely different focal length. But a universal adoption of this system is what is wanted.

§ 10.—Care of Lenses.

A few words on the preservation and care of these beautiful products of science and art will not be inappropriate here.

When lenses have been out of use for some time, or have been carried to a distance, they should be carefully unscrewed and wiped out with a soft old linen handkerchief, or a piece of chamois leather. Nothing else should be used.

If the lenses have stood only for a short time, they may only require wiping on the exterior surfaces. They should first be examined, and if free from dust, it is better not to wipe them. Too much wiping is as bad as too little, and it may be set down as a general principle, that the less lenses are touched *with anything* the better; especially the fingers should never touch them.

With many forms of lenses, convenient caps of morocco lined with velvet are now furnished. This is an excellent arrangement, as dust is excluded, and the amount of wiping is diminished. These caps are also very convenient for covering and uncovering the lens. Such should be made and furnished with all photographic objectives. Something similar, or a light brass cap, to protect the back lens, would also be very useful with all lenses intended for field use.

It is a disadvantage to keep the lens in a cold place, and then, perhaps, suddenly remove it to a warm one. A dew may form

on the lens while the image is being impressed, or before, and may escape observation. This may even happen by a mere change of position in taking views, by the photographer removing his apparatus from a cool position to a warmer and damper one.

Lenses should never be left lying where the sun, or even a bright light, can fall upon them, as strong light has a tendency to darken the color of the glass and increase the exposure necessary. For this reason, where stereoscopic lenses are occasionally used separately, this use should be divided between the two. If one of the pair is always used on such occasions, it will tend gradually to work more slowly than the other, so that the two can no longer be used advantageously together.

The care of the lens should also be extended to the brass mounting. If this is allowed to become dented, or is in any way roughly treated, there is danger that the centering may be interfered with, and the working of the objective thereby impaired. Second-hand objectives should always be severely tested before purchasing, and no one should be induced to acquire a lens in this way, unless he feels fully capable of judging the objective on its own merits by a careful trial.

CHAPTER VI.

PHOTOGRAPHIC PERSPECTIVE.

§ 1.—Nature of the Image formed by a Lens.

WHEN it was first found that the image of the camera could be fixed, and that thus representations of natural objects could be produced with critical exactness, the enthusiasm that resulted was unbounded. Gradually this was mixed with severe disappointment. The representations produced were, for the most part, destitute of beauty even where the subjects themselves were very beautiful. Everything was present in the picture, the delineations were correct, or nearly so, and yet the result was most unsatisfactory.

It soon appeared that good apparatus and a competent knowledge of the process constituted only a very small part of what

was needed for obtaining a pleasing picture. A natural sense of the beautiful, and a sufficient acquaintance with the rules of art, proved to be at least equally necessary. Without these last, the best point of view at which to place the camera could not be selected, the time of day for securing the best aspects of light and shadow could not be known, nor how much to include on the plate, nor where to place the horizon line, &c. &c. The more intelligent photographers gave earnest attention to these points, and in proportion as they mastered them, their works found favor. Those who disregarded them quickly sunk out of sight.

Even the nature of the image formed by a lens cannot be well understood without some knowledge of perspective. It will well repay any earnest landscape photographer to study this science in the text-books specially devoted to it. Here, the limit assigned by the author to this manual will permit of a very brief description only.

PERSPECTIVE is the science of representing solid objects upon a flat surface.

If between the object to be represented and the eye, we interpose a plate of glass, and keeping the eye steadily fixed in position, we draw lines upon the glass corresponding with the objects, we shall obtain a representation of these objects in correct perspective.

Let us select a building for example, and on the plate of glass mark the point at which we see all the corners and intersections of the lines of the building. Then connecting these by drawing lines on the plate we shall obtain a representation such that when held up in its proper position between the eye and the building, every line on the glass shall cover the corresponding line of the building. This will be *one* drawing of the building in correct perspective.

But we shall immediately notice that if we change in the least the distance of the eye from the plate, the correspondence of lines instantly ceases. Still keeping the eye exactly opposite the centre of the pane, let us draw back, so as to be *farther* from the window; at once every line of the building has started *out*, beyond the corresponding line of the original drawing, and we obtain a *larger* picture than before.

By altering the position of the eye, any number of different pictures will be obtained of the same object, and these *correspond*

with the pictures obtained from lenses whose absolute focal lengths are equal to the distance of the eye, in each case, from the pane of glass.

If the arrow $A B$, Fig. 67, represent the edifice, $P' P'$ the pane

Fig. 67.

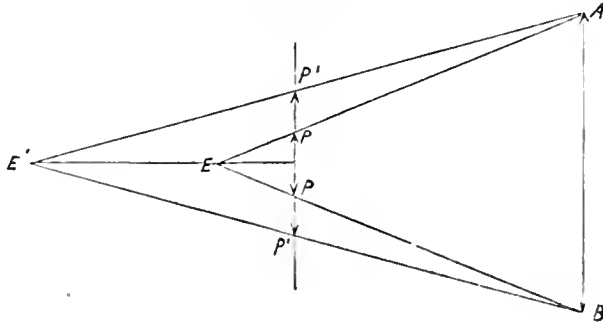

of glass, and E the eye, the edifice as represented on the pane will have the height PP . If the eye be withdrawn to E' , the image will be enlarged to $P'P'$.

Now, if the eye be replaced by a lens whose focal length is the same as the distance of the eye from the pane, the image formed by that lens will be precisely the same as seen by the eye—reversed, of course.

The lens L forms on the screen an image I' (Fig. 68) of the arrow precisely as large as the image I seen by the eye when placed at L , upon the pane at I , the distance of the eye to the pane being the same as the focal length of the lens; that is, the distance from L to the centre of the arrow.

Fig. 68.

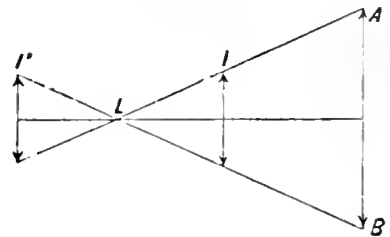

If now, keeping the eye at L , we move the plane I , backwards and forwards, we shall obtain any number of images of the object AB . By drawing lines from L to all parts of AB , it will be seen that the triangles are always similar; that is, any triangle EAB (Fig. 67) will always be similar to the corresponding triangle $EP P$. All parts of the image PP will therefore have the same proportion to the corresponding parts of the object AB . If any one dimension be altered, or if PP be increased to $P'P'$ by drawing back the eye to E' , all others will be proportionately changed. It follows, therefore (and this is very important), that all these images of the object will vary in size only; that is, they will be magnified or reduced images of each other; and as these images are identical with those formed

by lenses placed at L (Fig. 68), having focal lengths respectively equal to any distance from the eye to the pane, we draw the conclusion that *similar lenses of different focal lengths, placed at the same spot, give representations which differ from each other in size only*. If the picture given by a small lens be magnified (for example, in a solar camera) to the size of the picture given by a large lens, the resulting picture will be identical with it, supposing the lenses to be perfect instruments. The perspective angles will be the same. But this is only true when the lenses have been placed all successively on the same spot.

On the other hand, changing the position of the lens, or of the eye, makes a complete difference in the nature of the image formed. If $A B C D$ be the side of a house seen obliquely, the

Fig. 69.

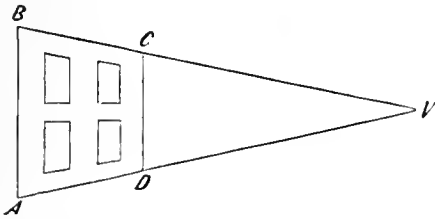

top and bottom lines, if continued, will meet at a vanishing point V , and the perspective angle $B V A$ will be greater or smaller, according as we place ourselves nearer to or farther from the building. The nearer we approach, the nearer the point V comes in, and the more abruptly the apparent size diminishes from $A B$ to $C D$. As any good photographic lens placed in the same position as the eye gives the same result, it follows that the nearer we go with our lens to the edifice, the sharper will be the perspective angle at B .

As the influence of these two conditions, viz., the focal lengths of lenses, and the distance at which they are removed from the

Fig. 70.

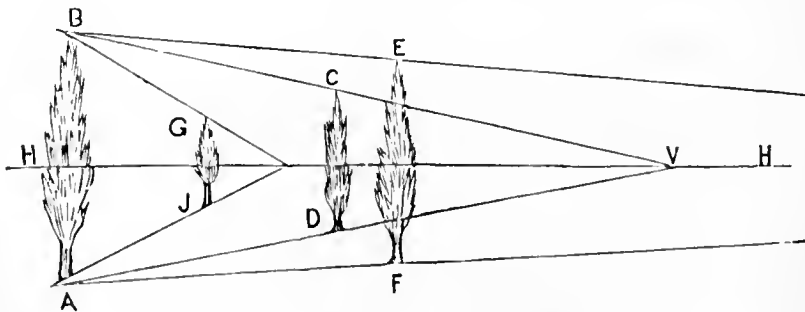

objects should be very clearly understood, the writer has endeavored to further illustrate it by the accompanying diagrams. Fig. 70 he has drawn in exact proportion, so that it exemplifies exactly, and not merely approximately, the mode of rendering

of two given objects by each of two lenses of very different focal lengths.

Let us imagine two trees of equal height standing the one somewhat farther than the other, and considerably to one side. Let us assign to both the height of 50 feet, and let us first place our camera so that the nearer tree is distant 600 feet. Let us first take a lens of twelve inches focus. The tree will have the exact height AB , or one inch, upon the ground glass.

Let us now suppose that the second tree is distant 1000 feet, or 400 more than the first.¹ Its image on the ground glass will measure six-tenths of an inch in height, and it will occupy the precise position CD , as shown in the figure.

Next let us for comparison substitute a lens of very much longer focus, thirty inches. And let us recede to such a distance that the image of the nearer tree shall occupy precisely the same height AB as it did before. To accomplish this we shall be obliged to recede to the distance of 1500 feet. How will now the second equal tree be represented?

Instead of measuring six-tenths of an inch, as in the previous case, it will be found to be .79 inch, or very nearly eight-tenths. It neither stands in the same relation of height, nor does it occupy the same position, but is represented at EF .

Let us next substitute a lens of four inches focal length. In order to produce an image of the first tree of the same height as in the first case, we shall be obliged to advance to within 200 feet of the first tree. And then the second tree will be found to have a height on the ground glass of only .33 inch, or one-third of an inch. Its place will also be totally changed; and it will be found at GJ , showing only that apparent height which it has in the figure.

If now we consider the equal height and the relative position of these trees, we shall see that the image formed by the first lens of twelve inch focus preserves a truthful relation between these objects, and conveys it to the eye.

On the contrary, the long focus lens brings the second tree so far forward, and gives it so nearly the height of the first, that we do not at all realize that it is so much farther away. The eye is completely deceived. And this fault is incident to all lenses of

¹ These distances are always measured upon the line of sight EC , Fig. 76, and will be presently explained, and the mode of determining apparent sizes explained.

very long focus, that they do not preserve the *relative planes of distance*, but drag objects that belong to the middle distance, into the foreground.

The fault of the very short focus lens is in an exactly opposite direction. The second tree is so excessively reduced in size that the eye to account for this is driven into one or other of two errors, either it misconceives the *height* of the second tree, and imagines it to be smaller, or it misconceives the *distance*, and imagines the object to be much farther.

So the vanishing point which in a correct representation is at the point V , is, in the short focus lens, drawn in to V' , and, with the long focus lens, carried far beyond the limits of the diagram.

The author has chosen trees to illustrate this point, but the principle is of course universally true. So the side of a house, seen at a suitable distance, and with a lens of moderate focal length, may present the appearance $A B C D$, Fig. 71. When we approach nearer, and, as before, substitute a lens of smaller focal length,

Fig. 71.

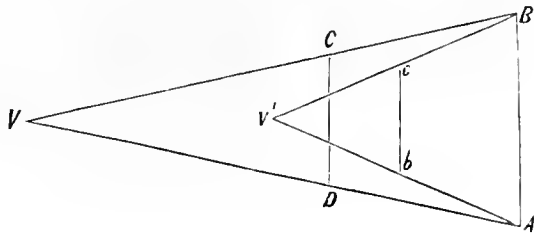

so as to keep some one line $A B$ of the same height as before, the image assumes the appearance $A B c b$.

There is a certain subtlety in applying these principles to practice, which requires close attention. Although the character of the image, as distinguished from its mere size, depends upon the distance to which we go from the object, and not upon the lens, yet, nevertheless, lenses of small focal lengths give almost always very incorrect pictures, because such lenses are brought too near to the objects, and the sharp perspective angle $c B A$ results, which is always offensive, and may legitimately be termed incorrect, because it gives incorrect conceptions of the object delineated. In some cases where an excessively sharp perspective angle is introduced, the building will actually seem to be falling forwards, and this may happen just as easily with a draughtsman's sketch as with a photographic view. In the latter case a longer focus lens should be used, and taken to a greater distance.

If, for example, it be required to photograph a large edifice, so that the image shall be only three inches high, and we take a four-inch lens and go to such a distance as will secure the size required, we shall get a picture with the sharp angle CBA ; but if we take a lens of eight to ten inch focus, and go to such a distance that the image is reduced to the same height, three inches, we shall get a natural angle CBA , the actual apparent height AB remaining the same in both cases, precisely as exemplified in the cases already considered.

As the principles here involved are of much importance in obtaining satisfactory representations of buildings of all descriptions, the author subjoins some illustrations that will exemplify them strikingly. Fig. 72 gives a view of Girard College as repre-

Fig. 72.

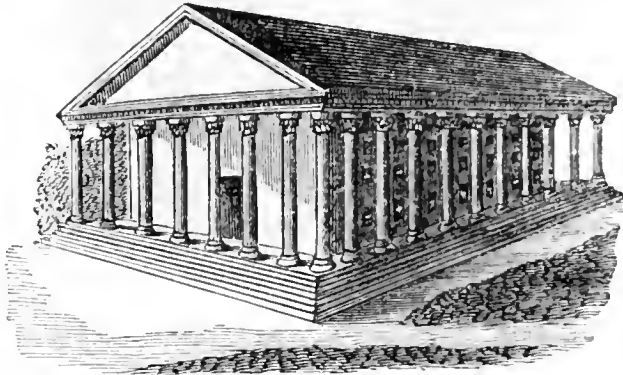

GIRARD COLLEGE.—View exemplifying the exaggerated perspective produced by very short focus lenses.

sented by a very short focus lens. The sharpness of the upper angle will be remarked, and also the unnatural effect given to the building in consequence of the vanishing points being so much drawn in.

On the other hand, Fig. 73 shows the same building as represented by a much longer focus lens, not planted on the same spot,

Fig. 73.

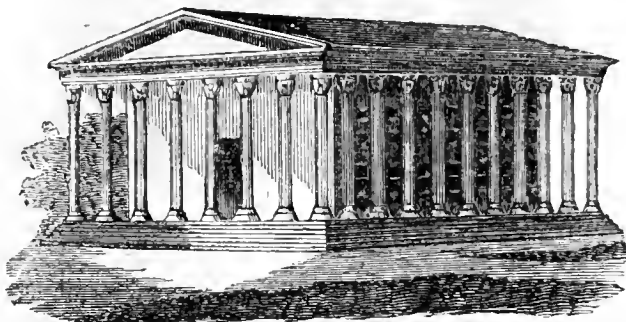

GIRARD COLLEGE.—View showing the correct perspective produced by longer focus lenses.

for then the result would have been a much larger picture, with the same angles as the former. But when the longer focus lens is made to produce a picture of about the same size as the other by removing it to a greater distance, we then get the effect shown in Fig. 73, in which the perspective is natural and agreeable to the eye.

In order to illustrate the principle more fully, the author sub-joins two oblique views of a Gothic front, the one (Fig. 74) show-

Fig. 74.

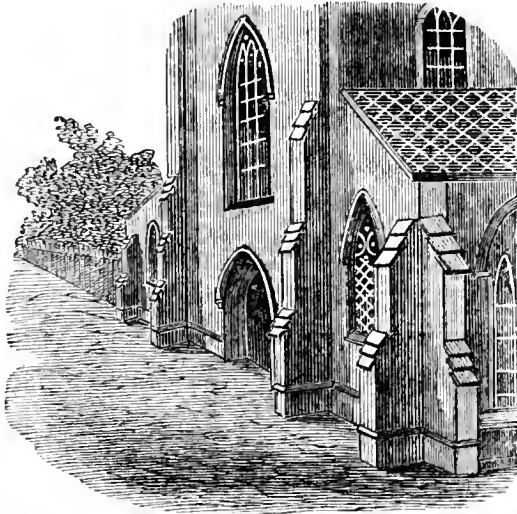

WEST FRONT OF ST. MARK'S CHURCH, Philadelphia.—Exaggerated perspective of short focus lens.

ing the exaggerated and unpleasing effect of the short focus, by which the correct relation between the nearer and farther portions is destroyed.

Fig. 75.

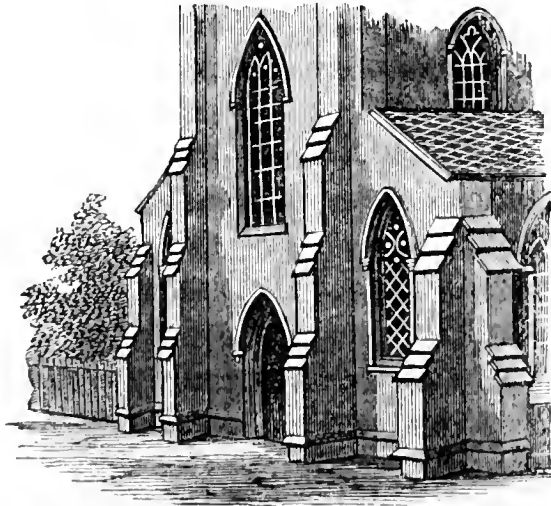

ST. MARK'S.—Correct perspective of longer focus lens.

On the other hand, Fig. 75 shows the same front seen from the same direction, but as represented by a longer focus lens placed at a greater distance.

The practical application of these rules is farther somewhat complicated by the fact that it is necessary to take into consideration the actual size of the picture; for it is an unquestionable fact that the *eye will support perspective angles in a large picture, that it will not in a small one.*

If, for example, we take a small picture *C B A* (Fig. 69), and magnify it considerably, we shall find that the perspective angles, too sharp before, lose this effect, and seem more natural. (The experiment is a surprising one, and must be tried to be appreciated.) This is one reason why the small photographs taken with very short focus lenses are so much improved by magnifying them. Their caricatured, or, as it is technically termed, *violent*, perspective, intolerable in such small pictures, becomes more endurable in the large one. On the other hand, a large picture, in which the perspective is appropriate and suitable for its size, cannot be reduced without injury. Even if the reduction be absolutely perfect, as when executed by a copying camera, the character of the design is destroyed. Engravers know this, and know that a large architectural drawing cannot be reduced with advantage; and the same truth is recognized by all artists. Ruskin remarks that true perspective is infinite and unreducible in its nature. To every size of representation there is a certain size of perspective angle appropriate, or rather the appropriate size lies within certain limits, and these are only to be fixed by judgment and cultivated taste.

Farther, it is to be remarked, that as in every photographic image the focal length of the lens corresponds with the distance of the eye from the section on the window-pane before spoken of, it follows that every photographic picture, to give a correct impression, should be held from the eye at a distance equal to the focal length of the lens with which it was taken. It will be at once apparent that a view taken with a lens of four or five inches focus, cannot be held that near to the eye of a person with ordinary sight. It follows, therefore, that such lenses *never* can give truthful delineations of scenery. They may make pretty pictures, but these are wholly incorrect, as many must have noticed. A garden becomes a park. The farther part of a house is represented on so much smaller a scale than the nearer part, that the eye, accustomed to correct representations, is deceived, and imagines the farther part, by reason of its smallness, to be much farther away than it is. And thus the farther part being

dragged away, the house appears to stretch much farther back than it does in reality, and consequently to be much larger. Distant objects are dwarfed down, mountains become hills, if they but stand clear of the foreground.

As we see objects best at about 10 or 12 inches from the eye, this would appear to be about the best focal length for a lens. Still, as the eye does not discriminate closely in these matters, and is very tolerant within limits, lenses of all focal lengths, from 7 to 15 or 16 inches, may be employed with advantage. Beyond this, the pictures become flat and tame, and the impression of solidity is insufficient. The round pillar looks like a flat pilaster.

In these cases the defect is, to some extent, corrected by removing the picture considerably farther from the eye. We can here alleviate the evil in a way that we could not with the pictures of the short focus lens. Still, the effects are not good.

Portraiture.—Perspective is not without its bearing upon portraiture. All portraits taken with short focus lenses are incorrect. The nose is represented upon too large a scale for the rest of the face, because it is nearer the lens. And it is still worse with the hands and feet, if visible. If two or more persons be included, their relative sizes are not properly preserved, unless they stand exactly in line side by side. This incorrectness becomes quite striking where one person stands behind the other, and a lens of 4 or 5 inch focus is employed. The fault in all such cases depends upon the use of lenses of too short focal length, in order to work in a short gallery, and work very quickly. By using a lens of 7 or 8 inch focal length, and going sufficiently far from the sitter to get the reduction desired, all parts of the person will be harmoniously rendered, and the different persons composing a group will be represented in correct perspective proportion, whether near to, or at some distance from the foremost figure.

§ 2.—Plane Projection and Apparent Size:

Plane Projection.—In the foregoing we have always considered the perspective as referred to ordinary or plane projection, that is, the surface of the image is perpendicular to the line of vision. The eye looks in the direction EC at the view ACB , which, as delineated, is supposed to be projected on the screen or paper $A'B'$, held perpendicularly to the line of sight EC .

This enables us at once to fix the *apparent size* that any object will have in a plane projection, whether it be drawn or photographed. For suppose the paper to be held at one foot from the eye, that is, that $E C'$ is one foot. If the tree C is a hundred feet from the eye, that is, one hundred times $E C'$, which is now our scale, it will be diminished one hundred times. Therefore, if it is fifty feet high, it will be represented on $A' B'$ as half a foot. Precisely the same is true of a photographic representation.

Fig. 76.

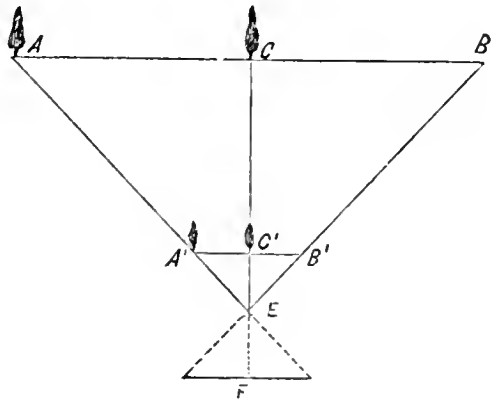

If the lens is at E , and has a focal length $E F$ of one foot, the tree fifty feet high and one hundred feet distant, will appear in the negative six inches in height.

If another tree of exactly the same height be situated at A , then, although that tree may be distant half as far again, it will be represented at A' of the same size as C' . It appears at first anomalous that two objects of the same size, at very different distances, should have an equal size in the image or picture; but this anomaly disappears by reflecting that, as the image is supposed to be held square before the eye, the image of the tree A at A' is *farther from the eye* than the image of the tree C at C' , so that $E A'$ stands in the same relation to $E A$ as $E C'$ to $E C$, and, therefore, if a sketch of a given size held at C' would exactly cover the real tree C , then a sketch of the same size held at A' would exactly cover the real tree A .

It follows, therefore, that *all objects of an equal size upon a line $A B$, perpendicular to the line of sight $E C$, are represented of equal size in the plane projection $A' B'$, whatever be their distances from the eye.*

An instance of this occurs in all drawings of fronts of buildings or rows of houses of equal heights, when the observer is supposed to stand exactly in front. In the picture the houses have the same actual height at the ends of the row, as in the middle, although they may be much more distant. So in the delineation of the front of the building, seen directly in front, the roof line is parallel to the base line, and shows no tendency to meet it.

§ 3.—Panoramic Projection.

This form of projection is never used in architectural delineations, and has only lately attracted attention in photography, from the introduction of the revolving camera.

In plane projection the image is projected upon a plane surface, as the name indicates; in the panoramic it is thrown upon one that is cylindrical.

The curved surface $A' C' B'$ receives the image, and as the point A' is no farther from the eye than C' , it follows that of the two equal objects A and C , A is represented smaller just in proportion

Fig. 77.

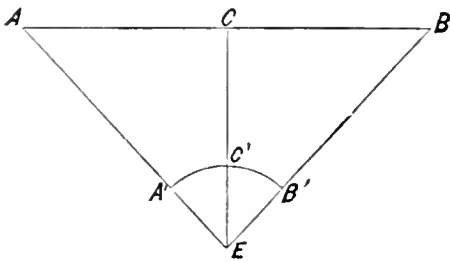

to the actual distance, so that if the distance EA be half as long again as EC , the tree A will have only two-thirds the apparent height of the equal tree C .

The representations afforded by panoramic perspective are correct only when they are received on a curved surface and so viewed. If printed on paper, the paper must be curved into the arc $A' C' B'$ of a circle, whose radius is the focal length of the lens with which they were taken. If such prints be laid flat (as they always are in practice), everything is distorted. With landscapes this may be tolerated, that is, the eye, if unfamiliar with the scene, may not detect the falsification, and the general effect may be pleasing. But as soon as this mode of representation is applied to architecture, its faults become strikingly apparent. If the front of a building be represented, the horizontal right line of the roof or cornice becomes a curve with the ends pointing downwards. The base line of the building becomes another curve, with the ends pointing upwards. All horizontal lines become curves, but vertical lines still remain straight, because the projection plane was curved only in a horizontal direction; it was cylindrical, and the vertical right lines in nature were all represented by vertical right lines on the cylindrical surface.



PART III.

PHOTOGRAPHIC MANIPULATIONS.

CHAPTER I.

THE DARK ROOM.

§ 1.—Regulation of Light.

THE dark room in which the operations of sensitizing and development are to be conducted, is most commonly made by partitioning off a portion of a larger room for this purpose. It consequently happens not unfrequently that this room is lighted only by an opening into the larger room, and has no window communicating with the exterior. This is a serious evil, and one to be avoided if possible. No sufficient ventilation can be obtained except from a window upon the street or yard, and for want of this, the operator's health is exposed to suffer severe injury.

The Window.—When access can be had to the open air, it is desirable that the window of the dark room shall not be so situated as to receive the direct rays of the sun. If this cannot be wholly avoided, it is better to have the sun fall obliquely, and later in the day, rather than perpendicularly, or in the morning; therefore a northwest exposure will be best, if it can be arranged.

It is much better to have a good light in the dark room than to work by a faint one, and this can always be accomplished by using proper precautions. The window need not be small, if it is properly protected.

There are two methods in common use: the use of yellow glass, and the coloring, or otherwise guarding of common glass.

The yellow glass sold in the shops, even when the darkest shades are used, is not in itself a sufficient protection. Even when direct sunlight does not fall upon the window, light enough

will enter to impress a plate; this the writer can assert from experience. As an additional protection, a shade of brown holland is useful, which in dark weather can be rolled up.

Pasting yellow paper, such as is made for common yellow envelopes, gives an excellent protection if the paper is stout, and if the sun does not fall directly on the window, this will, in many cases, be sufficient. The paper should be cut to the exact size of the panes, and attached by a border of paste. In this way the free open and shutting of the sash is not interfered with. The yellow glass is of course preferable.

For a long time past, the writer has substituted *green glass* for yellow. The orange-yellow shade of color imparted to light by the glass in ordinary use is very trying to the eyes of many persons. The green light, on the contrary, is pleasant both for the operation of preparing the plates and for developing. A tolerably dark, but not too dark, shade will be proper.

The light used may be (whether green or yellow glass be employed) either ordinary daylight, or artificial light. The latter has the advantage that it may be had always of equal power, which is of great use in judging of the density of a negative during development. In employing daylight through colored glass, more mistakes will be made as to the density of the negative than when an artificial light of uniform strength is used.

If a window is used for illumination, it should not be too small, so that the light, after being thoroughly divested of its actinic elements, may still be sufficiently abundant to render all operations easy. Ordinary print should be read with ease in the dark room, and this is not inconsistent with absolute immunity from fogging, if the precautions just mentioned have been suitably taken.

Fig. 78.

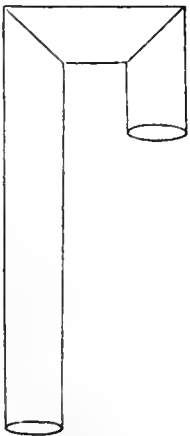

But a window for occasional opening, is not in itself, by any means, a sufficient mode of ventilation. In the roof of the room, a five or six-inch pipe should be set, the exterior part of which is bent twice at right angles, so as to point downwards; in this way neither light nor rain can enter.

An opening communicating with the outer air, near the floor, for the admission of air, is also very desirable. A slanting board is nailed against it, which freely lets pass the air, but excludes the light.

Or a *Ventilating Box* may be employed. Such a box is represented in Fig. 79. It is easily put together out of a few boards. A hole is cut into the partition of the dark room, corresponding in size to the opening G at the right hand end of the box, from which one side A B C D, is here supposed to be removed, in order to show the interior arrangement, and then the box is fastened close over the hole. The air enters at the opening H, in the bottom of the box, and passes through the partition, whilst the light is effectually excluded by the cross pieces E and F. Two such boxes should be used, one for the ingress, the other for the egress of the air. The former is better placed so as to communicate with the outside air. If this cannot be done, and both must be placed inside, one should be near the floor, the other near the ceiling.

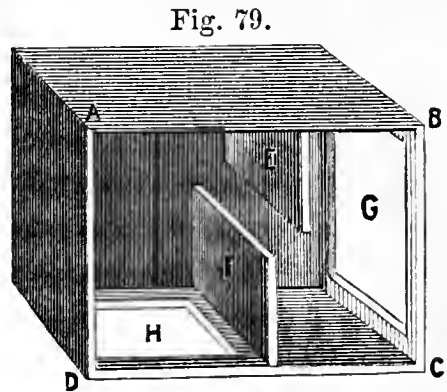

§ 2.—Arrangement.

The arrangement of the room will depend so much upon its size and shape, that it is difficult to give any general directions. But it may be said, that the place for developing should be in front of the window, and that near by it should be a sink with a tap for washing. The tap, in fact, should be so at hand that water can be made to flow over the negative at any instant to stop its development. This is very urgent, and any arrangement that does not accomplish this is exceedingly defective.

A good plan is to have a shelf eighteen inches wide round three sides of the room. The height of the shelf will depend upon whether the operator develops sitting or standing. If the former, the shelf should be just high enough to put the knees under, and no more. If standing, it should have a somewhat greater height.

If vertical baths are used for sensitizing, they should not stand on this shelf, but should be let into it, so that the top of the bath will be level with the shelf; at least this is advisable if it is intended to do this part of the work seated.

If the fixing is done in the dark room, the fixing bath and all utensils connected with this part of the work, should be as far as

possible from the sensitizing baths, and the *utmost* care should be taken to avoid the introduction of the minutest portion of the hyposulphite into the silver bath, to which it would be fatal.

The figure below represents an arrangement adopted by the author, where it was a great object to save space. A wide shelf

Fig. 80.

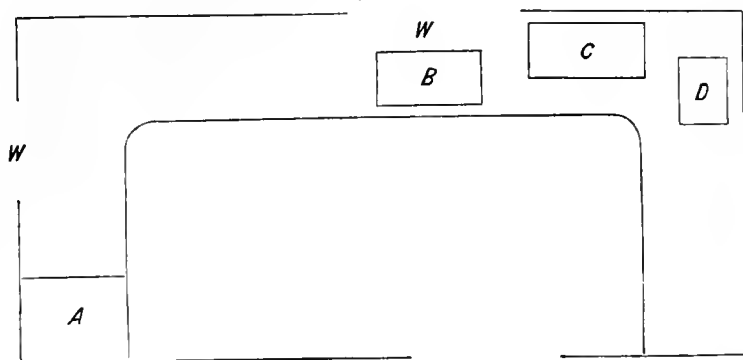

to be used as a table, runs round three sides. At *A* are the sensitizing baths, and near *A* is a small window of yellow glass, to coat the collodion and manage the sensitizing by. (This window is by no means essential.) Opposite to *B* is the principal window, looking north, and opening to the open air. In front of it at *B*, is the tray or sink over which the developing is done. This window comes down so that the bottom of the lowest pane is level with the top of the table. A window with a high sill in a dark room is a great nuisance. At *C* is the sink with a tap of water over it. At *D* is the fixing bath of hyposulphite.

A double-kneed pipe is set into the roof, and fresh air is introduced at the floor from the outside, as before described.

The dark room should be kept clean and free from dust. The chemicals that emit fumes should be kept elsewhere, and care be taken to avoid spilling hyposulphite solutions about, because whatever substances are scattered over the floor in solution soon dry, and are ground off into dust by the feet. This dust may rise and settle again in vessels and solutions. All such foreign matter is injurious, and nothing more so than hyposulphite.

Too much shelf space in the dark room is undesirable; it is an invitation to leave things there that are better away. No worse mistake can be made than that of keeping chemicals in the dark room. It happens that most of the substances used for after-intensifying emit vapors that tend strongly to produce fogging, and especially sulphide of potassium (liver of sulphur) and Schlippe's salt. Old solutions containing vegetable or other or-

ganic matter liable to turn sour or putrefy, are very injurious. A long succession of failures was once traced by a professional photographer to a bottle of sulphocyanide of ammonium, either originally impure, or into which something had been dropped that had set up a decomposition. In a word, there are so many suspicious substances, and injury when it comes is so intensely vexatious and so difficult to trace out, that it is best to be on the safe side, and to absolutely interdict the presence of anything in the dark room that is not needed for the coating, sensitizing, and developing, to the exclusion of all other operations.

It is still worse when the dark room is used as a work room for chemical operations, and when torrents of gases are generated that permeate the wood work and plastering, and slowly ooze out again for weeks.

Foul drains, or pipes communicating with sewers may introduce gases that will interfere with the work. The presence of turpentine and of fresh paint have been affirmed to interfere with negative work very seriously.

But the simple exclusion of these sources of trouble is not in itself sufficient. A complete ventilation is required, and a copious admission of pure air into the dark room is a matter upon which the photographer's health, possibly even his life, may depend. The recklessness shown by many in these respects is incredible, and can only be explained by an entire want of knowledge of the dangers incurred. It is a fact familiar to physicians that a daily exposure, even for a limited time, to an atmosphere impregnated with noxious fumes will do serious mischief, even when no inconvenience is felt at the time. Our senses rapidly familiarize themselves with injurious emanations, and cease to give us notice of them, even when they are silently and steadily doing their work of destruction.

Nor should any photographer require an assistant or person employed to do work which he would avoid himself by reason of its insalubrity. This, however, is often done, and is always thoroughly unjustifiable. Frequently the person so exposed is ignorant of his own danger.

It is desirable that the *temperature* of the dark room should not differ very materially from that of the glass room.

CHAPTER II.

THE GLASS ROOM.

§ 1.—General Remarks.

No subject concerns the professional photographer more deeply than the glass room. Chemicals, lenses, and cameras he can always obtain of excellent quality from dealers of reputation, but in the construction of the glass room he must depend to a large extent upon himself, acting under such information and instruction as he can obtain. It is certain that a very clever operator will occasionally obtain good pictures in almost any glass room; this is not, however, what is wanted. The disposition of light should be such as to facilitate to the utmost the really difficult task of regular success.

If any intelligent observer will place himself in a room lighted from *several* different directions, and taking a looking-glass in his hand, will observe his own face, as he stands in very different parts of the room, with very different illuminations, he will see a wonderful change as regards feature, character, and expression. Now, the object of the glass room is to obtain from each face its best, and at the same time, also, its characteristic expression.

If the observer with his hand-glass carefully notices the effects of different lights upon his features, he will be especially struck with the three following facts:—

1. That a level light, coming directly in front, *flattens* all the features.

2. That a light directly from above produces an opposite effect, exaggerating the projection of the brows and nose, rendering the eyes cavernous, and drawing out the cheek bones.

3. That a level light from one side produces a most unpleasant effect, causing what is known as a "hatchet" expression of face.

Pursuing his trials further, he will find that the right light to use consists in a combination of the three into a *front upper-side* light. To produce this light is the great object of the disposition of the glass room; bearing in mind that for different sitters a variation of light must be at command, and that as the position, strength, and character of the light vary at different hours of the day, the means of compensating for, and correcting these changes, must be at hand.

Selection of Glass for Glazing.—The experiments of Mr. Gaffield and others have shown that very pure white specimens of glass are more apt to change color by the continued action of sunlight, than those that are a little colored. The explanation appears to be that the freedom from color is obtained by the addition of manganese in the making of the glass, and that glass to which manganese has been added is apt to change by sunlight to a color which is sometimes purple, sometimes golden; in either case greatly obstructing the passage of the active rays. It was found that fine white plate glass was the most liable to change of all the sorts examined. A light bluish-green window-glass is that which is most suitable for glazing the glass room. It would be desirable if glass manufacturers would furnish glass expressly for glazing photographic rooms, guaranteed free from manganese.

§ 2.—Ridge Roof Construction.

By far the best light for the portraitist is the pure, soft, diffusive light that comes from a northern exposure. An abundant supply of this light is of the highest value. It is best, therefore, that the length of the glass room should be east or west, and that the north light should be received on one side. The best photographers all over the world are now pretty generally agreed in preferring what is known as the Ridge Roof System of Construction, a section of which in various forms is shown in the figures.

Fig. 81.

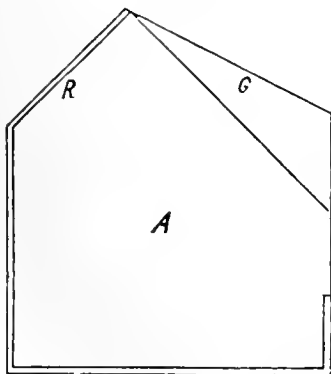

Fig. 82.

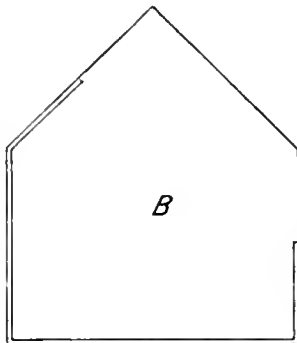
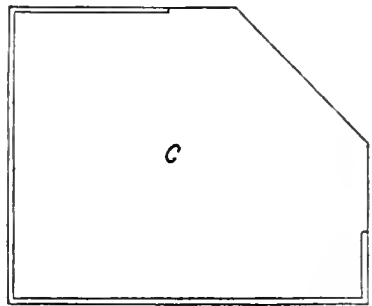

Fig. 83.



The single line represents the glazed parts; the double line, ordinary walls, ceiling, &c.

Of these forms *A* is the preferable one. Great differences of opinion exist as to the best pitch to give the light side of the roof. Two different inclinations are shown in Fig. 81 by the line above, and that below, *G*. Some, however, make it still flatter

than the flattest of these, even as little slope as two inches to the foot. Others again will give it a pitch of thirty degrees or more.

Fig. 84 shows a perspective view of the interior of this construction.

Fig. 84.

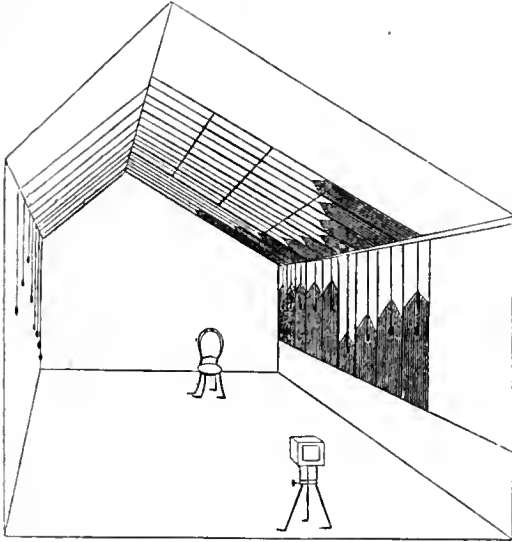

The principal length from front to back is, of course, east and west, the glazed side being towards the north. The glazing is carried half way or thereabouts; at least it is better that it should not go farther, in order that the camera may be well protected from the light. It will be necessary, or, at least, far better, to have a screen so interposed as to shut off useless and injurious light from striking the camera from the glazed portions. It is, indeed, a most

excellent canon, that *the eye, if placed in the position which the lens is to occupy, shall not see any uncovered glass*. It should never be forgotten that neglect of this will diminish the brilliancy of the image.

The relation between the dimensions of the glass house will be better understood by the perspective drawing of its exterior

Fig. 85.

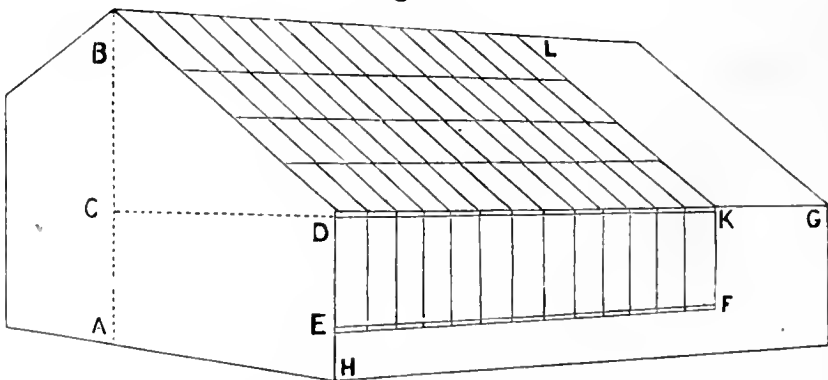

view, Fig. 85. If a perpendicular be dropped from the top line of the glass to the floor, its height, $A B$, represents the extreme height of the glass. A line $C D$ is drawn at right angles to it, and the angle $C D B$ is that of the inclination of the roof. The glazing begins at the height $E H$ from the floor. $H D$ is the height from the floor at which the top light commences.

The pitch of the upper skylight is usually measured by giving the angle $B D C$. But as few carpenters are able to lay off a roof

at a given angle, the following table will be found useful. It gives the actual height B C for any desired angle, taking the breadth D C as 10, from which the height is easily found for any other breadth, greater or less.

TABLES OF INCLINATION IN FEET FOR A GIVEN ANGLE OF PITCH.

TABLE I.								
Angle of pitch of roof	=	10°	;	if	depth	C D	=	10, height B C = 1.76.
Angle	"	"	=	12°	"	"	"	"
Angle	"	"	=	15°	"	"	"	"
Angle	"	"	=	20°	"	"	"	"
Angle	"	"	=	25°	"	"	"	"
Angle	"	"	=	30°	"	"	"	"
Angle	"	"	=	35°	"	"	"	"
Angle	"	"	=	40°	"	"	"	"

That is, with a pitch of 10°, the roof will rise 1.76 (1¾ nearly) feet in ten, and so on for other inclinations. To exemplify the use of this table: Suppose it be intended that the skylight shall have a pitch of 20°, that the room is 22 feet wide, and that the skylight shall come perpendicularly over 12 feet of these 22, what perpendicular height must the carpenter give the upper edge B of the skylight above its lower edge D G? or, in other words, if C D is to be 12 feet, what height must B C have that the roof may pitch 20°?

Referring to the table, we get for 20° the height corresponding to 10 feet of base, viz. 3.64

For each additional foot we add one-tenth of this, viz., for

2 feet 73

And find $4\frac{37}{100}$ feet, or 4 feet $4\frac{1}{2}$ inches nearly . . . 4.37

The following table shows the perpendicular height for different angles when the length of slant line B D is given:—

TABLE II.								
Angle of pitch	=	10°	,	slant	line	B D	=	10, the height B C = 1.73.
Angle	"	"	=	12°	"	"	"	"
Angle	"	"	=	15°	"	"	"	"
Angle	"	"	=	20°	"	"	"	"
Angle	"	"	=	25°	"	"	"	"
Angle	"	"	=	30°	"	"	"	"
Angle	"	"	=	35°	"	"	"	"
Angle	"	"	=	40°	"	"	"	"

As an example, suppose it be intended to build a skylight fourteen feet square, and to give it a pitch of 15°, what perpendicular elevation must be given to the top ridge?

Consulting Table II. we find for 10 feet and angle of 15° 2.59
 For the four additional feet of the 14 we add four-tenths of
 2.59 1.04

And find $3\frac{6}{10}$ feet, or 3 feet $7\frac{1}{2}$ inches nearly . . . 3.63

The form *A*, Fig. 81, may be still otherwise varied. A "lean to" roof may be substituted, that is, the glass *G* may be continued all the way with the same pitch till it reaches the side wall, which is then much higher, and the roof *B* is thus superseded.

Mr. Fennemore's glass room is arranged upon a different plan, as will be seen by the adjoining figure. Its dimensions are:—

Top light, width	19 feet.
" length	12 "
Side light, width	12 "
Greatest height	12 "
Lowest "	7 "

The pitch of the top light is five feet in twelve, or five inches to the foot. Reference to Table II., p. 117, will show that this corresponds to an angle of between twenty-four and twenty-five degrees.

Fig. 86.

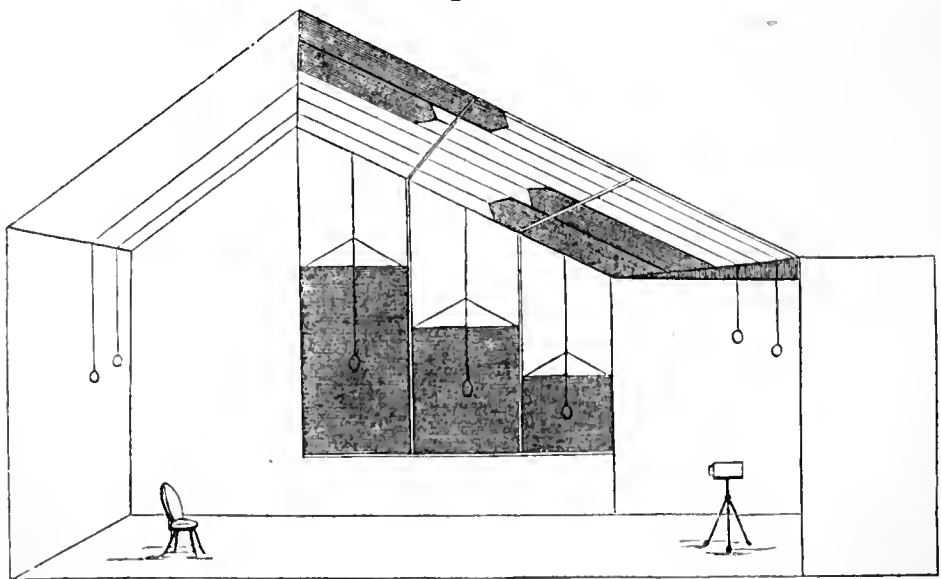

Mr. Wenderoth's skylight is in form somewhat like that of Mr. Fennemore's, that is, it is *A*, Fig. 81, widened out. But the sitter has his back to the west wall, and the line from the camera to the sitter has the usual east and west direction. He has, in

addition, arrangements for admitting light at the ends, and also a narrow line of opening just at the top of the south wall. This last, without the most careful management, must lead to cross lights, and is probably of no real use.

Sarony uses a longer room, with glass at each end, in order to carry on two sets of operations at once. Both ends have light from the northward. The roof-light is 13 feet long, and 13 feet along the slides slanting upwards, which have an angle of thirty degrees. The side light commences at a distance of five feet from the floor, and meets the roof three feet above this; it has the same length, thirteen feet, as the roof-light that joins it. The construction is, therefore, very similar to Fig. 85, if we suppose another glazed portion added to the farther end. The height $E H$ is five feet, the glazed side has a height $D E$ of three feet. The upper skylight is square, the lengths, $B D$, $D K$, being each thirteen feet. The pitch or angle $B D C$ is thirty degrees. It is easy, by Table II., p. 117, to find the perpendicular height of the top of the skylight from the floor. The table gives for the absolute height, $C B$, of the sash, 6 feet 6 inches, and as $D H$ is here 8 feet, the whole height, $A B$, is 14 feet 6 inches.

Gurney's new studio is 18×30 , with a top light 15×13 , the side light 15 feet long and 7 high, beginning at a height of $2\frac{1}{2}$ feet from floor. The top light is at its junction with the side light 9 feet 6 inches from floor; at its highest point 11 feet 8 inches. Its inclination is, therefore, 2 feet 2 inches in 13, or 2 inches to the foot. This is 1.67 feet in 10 feet of slant line. Referring to Table II., p. 117, we see that this corresponds with an inclination a little under ten degrees, or not quite one-third as much as that of the last-mentioned studio.

In a new studio, recently completed, Loescher and Petzch, of Berlin, continue to use the ridge roof form, but built in somewhat different proportions from their former studio, described in the first edition of this manual. Their light fronts north, and the skylight is protected from the direct sunlight by higher buildings south of it. The glass room is 35×17 —the lower side of the skylight is 10 feet from the floor, the higher 14, the inclination is, therefore, 4 feet in 17. The whole side of the room, and about three-quarters of the roof, are glazed. This plan involved so great an exposure of side light, that especial means were found necessary to exclude perfectly all that was not needed.¹

¹ For fuller details and figures see *Phila. Photog.*, 1870, pp. 89 and 117.

The particulars of the construction of the glass room of a celebrated Parisian photographer, Reutlinger, have been given to the public. On the north side there is a perpendicular glazed portion, 22 feet long and 12 high. The glass roof has only 14 feet of width, protected by an awning controlled by pulleys inside, to cut off direct sunlight. The glass overhead is ground glass, and so are the sides as high as the eyes. The entire length of the room is about 44 feet.¹

Salomon, of Paris, uses a system corresponding for the most part with Fig. 85. But as one of his essential peculiarities lies in the use of a diagonal background, a sketch of the interior of his glass room will be given in the section on backgrounds.

Any one of the forms of glass room which have been here particularly described, will, in good hands, give good work. The whole system used by Loescher and Petzsch seems that most in accordance with sound principles, and without meaning in the least to detract from the excellence of the others, is that which is most strongly recommended here.

Whatever system is adopted, the following precautions will be found useful: Keep the end at which the camera is placed dark, and avoid having much illumination in the space between the camera and the sitter, because the slight dust that always floats in the air of a room reflects back a portion of any light that falls upon it, and so takes from the clearness and brilliancy of the work. As to the power of dust to do this, any one may convince himself by observing how visible the path of a sunbeam in a dark room is rendered by the dust that floats in the air, and it is a general rule that *whatever is capable of sending back light to the eye will also send it to the camera*. Dust in the glass room is in every respect a serious evil, and should be carefully prevented.

Closely allied to this principle is that the direction of the light that is admitted should be *towards the sitter and not towards the camera*.

It cannot be expected that any one system of illumination should be best for all purposes. Groups are best taken in a well-diffused light, affording to all parts an equable illumination, whereas for many sorts of portraits, such a light is unmanageable: in fact, many skilful operators, in making single portraits, try to suppress all strong light except that which falls directly

¹ *Photographische Mittheilungen*, No. 41, p. 130.

on the head. Groups also are best managed in a tolerably large room, whereas experience seems to show that single heads are best taken in rather small glass rooms, and there is no doubt that in a small room the pose is more rapid than in a large one; light becomes more diluted in a large room, and the sitter is farther from the glass.

Length of the Glass Room.—This will be determined by the character of the work to be done. The shortest length in which a full-length card portrait can be taken is 21 feet, full-length cabinet 24, full-length whole size 40. These requirements are those that will fix the length, because heads and half-lengths can always be taken within a shorter space. The breadth of the room will need to be approximately half its length.

The quality of the glass needed for the skylight has already been discussed. As to its management, it may be either the simple, clear glass, ground glass, or blue frosted. Some persons are under the belief that the blue color increases the actinic power of the light. This is a complete error: any skylight will work *faster* without than with such an application. The advantage of the frosting lies in very greatly diminishing the glare, so that a larger amount of active light may be admitted without inconveniencing the sitter. Ground glass is little used here, it greatly softens the light, but also greatly diminishes its strength. It has been found that whilst ordinary (clean) glass holds back but about five per cent. of the light, ground glass stops one-half. Nevertheless ground glass is largely used in France, and with great success. The blue stippling is the favorite method here, and is extending to Germany.

To apply it, blue frosting is first brushed on with any ordinary flat brush. Then a thick round painter's brush is tied up with twine to about an inch of the end, and is tapped against the moist frosting until the effect is obtained.

Ventilation.—Some portion of the glass side should be arranged to slide, or there should be somewhere a window that can be raised. It is true that its use will be somewhat limited: the photographer cannot of course run the risk of having a puff of wind derange drapery, and even when opened between exposures there is danger of the introduction of dust. But in weather in which there is no dust in the atmosphere, it is highly desirable to get the benefit of the freshness of the exterior air. Nothing

tends more to give a portrait an old and faded expression than a hot close atmosphere, the depressing effects of which are apt to tell quickly upon the expression.

‡ 3.—Control of Sunlight.

An important consideration presents itself with respect to all the forms of roof and glazing just shown in section. Even if the roof looks directly to the north, it is impracticable to give it so high a pitch that the sun shall not shine over the ridge at midday, and it must also shine over the ends morning and evening, unless higher walls abut against them. Various efforts have been made by different photographers to obviate this difficulty. Some select a position where the walls of adjoining houses afford a screen, some use awnings moved by pulleys, others trust to excluding the sun by curtains and shades inside. These, indeed, are of course always necessary to regulate the amount and direc-

Fig. 87.

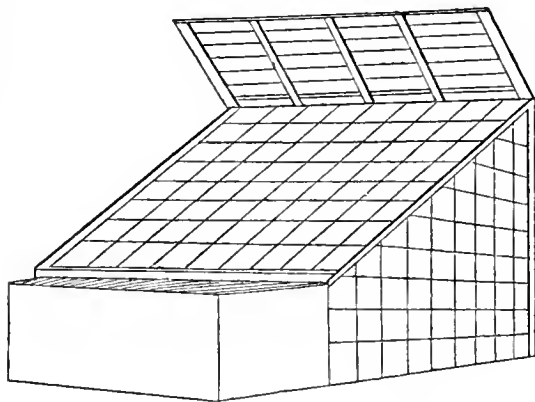

tion of light, independently of direct sunbeams. An effectual course, in the absence of protection from other parts of the building, or of adjoining buildings, is to construct a framework of boards, as shown in Fig. 87. This is valuable not only as respects light, but checks the overheating of the glass room.

The same figure is intended to show a system of construction sometimes adopted in this city; it is easy to make and cheap, but less advantageous than some others.

Some, however, trust so entirely to inside shades to exclude the sun, as to prefer a southern exposure, softening the sunlight by shades, and getting it under management as best they may. The solitary advantage that this system possesses is, that in dull weather the southern light is stronger than the northern.

Some, in order to get every variety of light, use a ridge roof, with equal slopes north and south, both glazed, so that the principal light may be taken from either side, as may be found best suited to the weather and the sitter. But this has a most serious

objection in the *intense heat* caused by it. The glass room becomes in hot weather a veritable hot-house. The sitters suffer—the chemicals do not work well.

To maintain a moderate temperature in the glass room is at best a difficult matter, even when not complicated by a southern exposure. A brick wall on the south side is a great protection, and there should be, if possible, a space between the southern slope of the ridge and the ceiling on that side. An excellent arrangement on all these grounds is represented in Fig. 88. At the upper angle of the ceiling *A*, a girder supports a wooden studding *B*. This allows an interspace *D* on the south pitch of

Fig. 88.

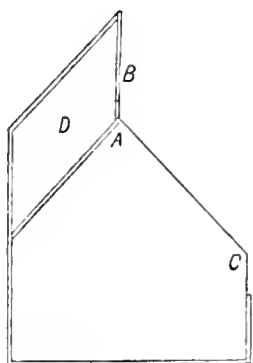
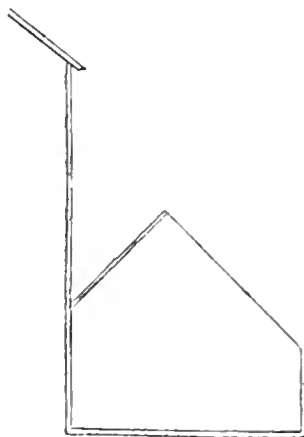

Fig. 89.



the roof—very effectual in diminishing the heat. The wall *B* tending to keep off the noon sun from the glazing *A C*.

It is evident that if the south wall supports a higher building adjoining, as shown in Fig. 89, somewhat the same result is attained. Such a form of construction requires especial care to render it water-tight at the junction of the roof and wall. The gutter in the angle must have a rapid pitch from back to front (which cannot be shown in the section), and must be thoroughly tinned by a good workman.

It will be important to keep the glass, especially its outer surface, clean, and an arrangement for scattering water over the top light will have the double advantage of affording an easy means of washing, and a method of cooling the room in hot weather.

Keeping the glass clean has an importance even greater than might be supposed. It has been ascertained by careful trial that the best and newest colorless glass stops *one-twentieth* of the light;

a moderate accumulation of dust, perhaps spread and splashed by rain and dew, may increase this source of loss five or tenfold.

§ 4.—Secondary Lights.

In all these sections the sitter is supposed to be at the far end, and looking towards the spectator. He will thus receive on his left side a powerful light from the glass roof, whilst his right side will be comparatively dark.

Now, a difference in light on the two sides is desirable, and even necessary, but this difference must not exceed a certain moderate measure. And the dark side of the face requires a *secondary light*, to give transparency to the shadows upon it. Three different methods are used for this end.

First, and most common, *reflectors* are used. Generally, a large screen covered with white paper, or white cloth, is placed on the side of the sitter, opposite the light. Some have used screens covered with silver paper; others, large mirrors.

Secondly, some have opened a window on the south side, and let in light directly on the dark side.

Thirdly, some object that these methods give false lights, especially affecting the expression of the eye, and, therefore, prefer to keep the south side of the room of a sufficiently light color to throw back a volume of soft white light, adequate to light up the shadows.

The brilliancy of the picture is always aided by excluding all extraneous light. The camera, therefore, should always be under an unglazed portion of the roof, and screens should be so arranged that, if the eye be placed where the lens is to be, it shall see no uncurtained glass. Too much glass is very objectionable, especially toward the direction of the camera. The air of a room always contains dust. The more strongly the dust between the sitter and the lens is illuminated, the more it will affect the picture, and always by taking from its brilliancy.

The *Tunnel System* is not to be recommended, though it is certain that good work has been done in this form of house, still the system is every way inferior to the ridge roof. In it, one end of the room, that in which the camera is placed, is lower than the other, and the vertical space between the two ceilings is glazed. Thus the strongest light is full in the sitter's eyes, at

the same time that its quantity is almost always deficient, seriously incommoding the operator in dull weather, and producing effects inferior to the ridge roof, in good.

It has been said that few photographers succeed in their first attempts at building a glass house; that they require the experience of a first failure to attain subsequent success. Failures of this kind are expensive, and infinitely vexatious. They are best avoided by obtaining beforehand a clear conception of what are the conditions essential to success, and then carefully and thoughtfully applying them to the position which their glass room is to occupy. Sometimes splendid success comes by mere chance. Mr. Hughes gives an instance in which the portraits produced by a photographer in a country town in England were so excellent as to induce him to travel a long distance to see the maker. He proved to be a man of limited intelligence, who, however, had chanced to erect an excellent room, where an abundance of soft, pure light from the north was received to the exclusion of cross lights. The photographer knew that his work was excellent, and ascribed it all to his personal skill, neither understanding nor appreciating the merits of his room. Encouraged by success, he erected a new gallery in another town, intended to be far better than his old one, but was confounded to find that in it he could not make anything worth having.

One material difference that will be found between a well and ill-planned glass room is, that in the former work can be continued till a late hour in the afternoon, and, even then, brilliant and well-modelled portraits can be got. It is, therefore (and this cannot be too clearly understood), *no proof of a good construction that the operator can show a piece of first-rate work made in it.* A glass room can hardly be so badly planned but that in some sort of weather, and at some hour of the day, good work may be done in it. The well-planned room is one that is always in a condition to meet the operator's needs.

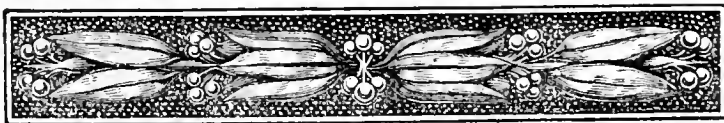

CHAPTER III.

PYROXYLINE AND COLLODION.

§ 1.—Pyroxyline.

THE manufacture of this substance has passed so much, in fact, so completely into the hands of those who make it their business, and who employ special methods, that it scarcely requires attention here, except in a brief way.

When any form of cellulose, such as cotton, paper, linen, &c., is exposed to the action of mixed nitric and sulphuric acid, a substitution takes place by which one or more molecules of NO_2 , hyponitric acid, are taken up by the cellulose. Several different compounds are thus formed, and often simultaneously. When the acid mixture is too weak, the cellulose is dissolved with abundant disengagement of red fumes. When it is somewhat stronger, and used before the heat generated by the mixture of the acids escapes, pyroxylines suitable for photography are produced, thoroughly soluble in mixed alcohol and ether. With lower temperatures and stronger acids, the more explosive form of pyroxline is produced, which does not dissolve well in the usual solvents.

The proportions most commonly employed in these later years, are to take equal bulks of the two acids, using sulphuric acid of full commercial strength (1.83 to 1.84), and nitric acid, sp. gr. 1.42. For each ounce of cotton, about twelve fluidounces¹ of each acid will be required. When this relative proportion of acids is varied from, it is more usual to increase the sulphuric acid than the nitric. The proportion of 12 sulphuric to 10 nitric is often used, and indeed the sulphuric may be increased until it

¹ As it is more convenient to measure liquids than to weigh them, it is common to take them in "fluidounces"—that is, a quantity equal to a measured ounce of water. Of course, with heavy acids, the quantity may largely exceed an ounce in weight. A fluidounce of sulphuric acid will weigh not far short of two ounces, one of nitric acid 1.42, nearly an ounce and a half. So in collodion formulæ the ounce of alcohol or ether means always a measured ounce, and consequently much less than an ounce in weight.

is threefold the bulk of the nitric. Some hold that this excess of sulphuric acid tends to increase the intensity of the pyroxyline produced. The mixing of the acids produces considerable heat. If the thermometer plunged into them rises above 150° , the mixture is allowed to cool; if it stands below, heat is applied. When the temperature is right the cotton is immersed in tufts, is pushed quickly under the liquid so as to become soaked immediately (otherwise red fumes may burst out from it, which, however, will be checked by a complete immersion). The whole cotton is got in as rapidly as possible, and is well worked round to insure equality of action. After eight or ten minutes of immersion, the cotton is drawn up with two stout glass rods, pressed against the sides, and then thrown into a bucket of water. Without a moment's delay the operator separates it out so that the water may penetrate it instantly. This can only be well done with the fingers, and as they would be corroded and stained yellow by the acids, it is best to use India-rubber gloves.

The pyroxyline then receives a very thorough washing in running water, is squeezed out and dried at ordinary temperatures and not near a stove or other source of heat. The washing must be sufficient to remove every trace of acid. Some, therefore, wash it with very dilute ammonia or solution of carbonate of soda, one ounce to the gallon, which must itself be washed out of the cotton with clean water.

As commercial nitric acid varies very much in strength, it is often found convenient to substitute nitrate of potash, and to increase the quantity of sulphuric acid, inasmuch as part goes to separate the nitric acid from the potash. It is also affirmed that pyroxyline made with nitrate of potash dissolves more easily, and gives a clearer solution, than that made with nitric acid.

Mix 200 parts of sulphuric acid of 1.84 (the full commercial strength) with 100 parts of dried and pulverized nitrate of potash, and keep them at a temperature of 147° to 150° F., which must be maintained during the operation. Stir with a glass rod till the lumps disappear. Then add six to eight parts of perfectly dry carded cotton. Agitate the mixture from time to time with a glass rod. After the action has continued for from ten to forty-five minutes, empty suddenly into a large pan of water. Wash thoroughly and rapidly with plenty of water; finally with boiling distilled water.

During the whole operation the temperature must remain over

147° or the pyroxyline is of inferior quality, and if over 160° the cotton is partly dissolved, and becomes shorter in fibre.¹

But, as already said, the manufacture of pyroxyline as a business is now so thoroughly understood, that it is no longer necessary for the photographer to prepare it for himself in order to have it good. On the contrary, it is probable that it would cost him much labor and some experience, to get it of as good quality as that which he can readily purchase.

It has been found that the quality of the original cotton used has much to do with the resulting pyroxyline, and that in general the best cottons make the best pyroxyline—especially the American Sea-Island. Also, that different cottons require different treatment; the same mixtures of nitric and sulphuric acids, or of nitre and sulphuric acid, which give the best results with one description of cotton, will give inferior results, or perhaps fail, with another. It seems to be well attested that a small quantity of *chlorine* in the nitric acid adds considerably to the intensity of the cotton, but diminishes its adhesiveness to the glass. The writer has observed that the *introduction of a chloride* into the collodion is attended with the same results, increased strength in the picture, accompanied with a tendency of the film to slip from the plate.

As to the keeping properties of pyroxyline, especially at temperatures above the common, there exists a great difference of opinion. It has been affirmed that pyroxyline exposed for several days to a temperature of 150° F. became uniformly decomposed, and that at the temperature of boiling water, some specimens explode. On the other hand, another experimenter declares, that pyroxyline was sealed up in a glass bottle and exposed in his garden for a year, the temperature of the interior of the bottle having frequently exceeded 150° F., and was found at the expiration of the time to be unaltered.

That pyroxyline does easily decompose there can be no doubt. And, also, that that decomposition is greatly aided by light—even by diffuse light. The writer prepared at one time several different pyroxylines, which were placed in glass bottles and corked. One of these bottles was partly used just before leaving town for the summer, and was by oversight left on the table, where it remained for nearly three months. The room received

¹ Belitzky, Br. J. XII., 4.

a north light only, and no sunlight. At the expiration of the time just mentioned, the pyroxyline was converted into a moist, sticky, spongy substance, not one-fifth the bulk of the original cotton; the vial was filled with red vapors of hyponitric acid, and the cork much eaten away. Other bottles left in a closed closet had not suffered.

For this reason pyroxyline should always be kept in opaque cases. It is also found that it keeps better when not too closely kept from the air. Pasteboard boxes are the most suitable, and the most usually employed.

M. Blondeau has published some interesting views on the subject of pyroxylines, which may be briefly expressed as follows:—

He considers pyroxyline to be a definite compound of *fulminose*, a substance isomeric with cellulose, and nitric acid. Of this fulminose little is stated except that it is decomposed at 140° F. into vapor of water and carbon. In the case of pyroxyline, the nitric acid which is in combination with the fulminose oxidizes the carbon to carbonic oxide, so that the products of explosion are carbonic oxide, nitrogen, and vapor of water.

M. Camuzat affirms that when collodion is poured into water it separates into three portions, a powder which sinks, a flaky portion that swims, and a third, which dissolves. In his opinion, the flaky portion is the only one which is essential or useful in photography. It seems almost certain, however, that the nature of the image must depend also upon any soluble organic matter present. In one hundred parts he found—

	Flaky part.	Powdery part.	Soluble part.
Best cotton	31	15	54
Ordinary	27	13	60
Powdery	27	7	66
Papyroxyl	60	5	35

Dr. Leisegang strongly recommends the substitution of *tissue paper* for cotton in preparing pyroxyline. The tissue paper is cut into strips and plunged into the acid mixture, which permeates it more rapidly and evenly. There is, therefore, less tendency to decomposition, and, it is affirmed, the product is more regular and uniform in its character. It is also claimed that it gives a remarkably smooth and uniform film when poured out upon the glass. Of this papyroxyl 4 to 5 grains only are dissolved in the ounce of solvent.

A variety of pyroxyline, called "alcoholic," has been introduced, but has been found of little use, even in our hottest summer weather, with the thermometer ranging from 90° to 100°. The ordinary pyroxylines, made up with perhaps a little more alcohol than in cooler weather, are preferred.

Xyloidine is a substance analogous to pyroxyline, produced by the same mixed acids, when made to act upon *starch*. It dries from its solutions as a *dead*, and not as a transparent film. *Nitro-glucose* will be discussed in Chapter XII.

The careful study which every department of photography has received during the past years has taught us the almost unlimited influence exercised upon photographic operations by the *nature of the pyroxyline used*. And especially that this affects the image obtained even more than the salts dissolved in the collodion. So that it is impossible to say that any particular salting is best for any particular photographic process. All we can say is, that a particular salting does best with some particular pyroxyline.

It has not been found practicable in cottons made for the wet process, to combine great sensitiveness and great intensity. The most sensitive cottons mostly give rather thin soft images, deficient in intensity, needing re-development, whilst those that give easily a full and bold image need a longer exposure.

These tendencies of the cotton necessarily affect the salting. A very intense cotton will do best with a good deal of bromide, a treatment very inappropriate for one tending to give a thin soft image.

Nothing but actual trial will determine the quality of a cotton: the indications which some rely on are mostly fallacious. A yellowish color has been supposed to indicate intensity, but in reality depends upon the wash water having contained traces of muddiness. Some think that a *short fibre* indicates intensity; this is likewise a mistake, as is the supposition that a *powdery cotton* is intense. These indications may, or may not, accompany intensity.

Nor can manufacturers produce at will, with any exactness, any particular quality of cotton, or even re-produce one that they have already made. The best that they can do is to avoid any wide variation.

§ 2.—Collodion.

When pyroxyline is dissolved in acetic ether, it makes a perfect solution, but dries opaque. The solution of good negative cotton in a mixture of alcohol and ether has the inestimable quality of leaving behind it in drying an absolutely transparent film, not to be distinguished from the glass on which it lies.¹ It is, moreover, acted upon in some way by nitrate of silver, with the effect of adding greatly to the ordinary sensibility of iodide and bromide of silver, so that in the "wet collodion process" a fraction of a second is sufficient, under favorable circumstances, to impress a latent image, full of gradation and detail, in the camera.

Formerly, the plain collodion was generally prepared separately, the salts were dissolved apart in a portion of the alcohol, and added subsequently. But as more care was taken in the manufacture of pure materials, and as the proper constitution of collodions came to be better understood, it became possible to prepare them so much more stable, that now it is more usual to prepare at once the collodion in the condition in which it is to be used. A good sound collodion, placed in a cool cellar, will keep two years, and is then by many preferred to fresh.

Influence of Alcohol, Ether, and Water on Collodion.—Alcohol and ether have been used in very different proportions in collodion. Water is present in quantity depending upon the strength or weakness of the other two substances.

The tendency of *ether* is to make a close, skinny, and tough film. Therefore, where it is intended to transfer a film, it is useful to employ a collodion with an abundance of ether.

Alcohol loosens the film and renders it porous. By rendering the permeation of the developer easy, the development is more rapid, and intensity is gained.

The action of *water*, or in other words, of alcohol and ether of low grade, is mostly injurious, except that when there is much tendency to make silver stains, water in the collodion seems to check them. With too much water there is a tendency to crapy lines, to form ridges, and especially to make a peculiar mottled appearance at the corner at which the collodion is poured off.

¹ Some varieties leave a "dead" film, which is rendered transparent in the varnishing, and this is by some operators preferred. It is doubtful if such a film is as strong as a clear one.

Proportions.—Formerly ether was used to excess, about 3 parts ether to 2 of alcohol. For some time past the practice of employing equal parts of each has gained ground.

Washing with, or steeping in, Alkalies.—Pyroxyline is often treated with ammonia, which has the effect of destroying any acid that may either have been left in it by the maker, or have been generated by a disposition to decompose. A more regular action is thereby obtained, and a certainty of avoiding the insensitiveness which acidity of the cotton inevitably causes.

The ammonia treatment is applied by diluting ordinary liquid ammonia with four times its bulk of water. Into this the cotton is plunged, and the solution well worked through it by alternate soaking and squeezing. The cotton is then to be well washed, squeezed, and dried, at ordinary temperature, or by a furnace flue, but not near a stove or open fire.

It is desirable that the drying should be complete to avoid introducing water into the collodion. The plan used by some of getting the cotton ready at once by moistening with alcohol, squeezing out, and repeating this several times, is not to be recommended, partly because the water is not thus completely removed as supposed, but principally because some sorts of cotton are somewhat soluble in alcohol. The writer has himself seen alcohol that has been used for this purpose gelatinize in drying, so much cotton had been taken up by it.

The proportion of pyroxyline to that of solvent varies, according to the character of the pyroxyline itself, from 4 to 8 grains; 5 to 6 is the most usual with average pyroxylines. Some cottons, however, make a collodion so dense that the proportion must be lessened; others make it so thin that 6 grains are insufficient. Something will depend upon the character of the work to be done—for instance, negatives require a denser collodion than positives (ambrotypes).

Relation of Salting to Development.—The very important influence exerted by the nature of the pyroxyline has been already dwelt on. The tendency of photographers at the present day is not to accept pyroxylines on the authority of the makers, but to try specimens and see what can be done with them, before mixing quantities of collodion with which it may prove impracticable to get the very best results.

It consequently becomes important with any particular cotton to ascertain exactly what it will do, and this cannot be found by

mixing it according to any routine formula to be followed by a routine development: this will only ascertain the suitability of the cotton for such treatment, and not its real value.

The question is not to find a routine formula, but what salting will do best with the particular specimen. Some will yield with $\frac{1}{2}$ grain of bromide as much softness and detail as others with $2\frac{1}{2}$. It is a good plan to make up a new sample in several portions, with varying quantities of bromide, until that which is best has been determined. And then having found the best salting, we must depend upon a *proper development* to get the best combination of half-tone and intensity.

A collodion giving a very weak image with plenty of detail is generally very sensitive, and will bear a very weak developer which deposits silver slowly and heightens contrasts, especially if the plate is kept in motion during development. This will be the proper treatment for a collodion tending to give weak negatives.

A collodion giving strong contrasts should have a strong developer which (as the writer long since pointed out) tends to soften the picture by a more equal deposit of silver. This action may be heightened by using so much developer as to wash off the plate a certain portion of the bath solution with which it is soaked.

Although a developer of 15 to 30 grains of sulphate of iron to the ounce will do very well for regular use and suit most cases, it will be a great mistake to assume that it will suit all collodions, or to persist in using it when the character of the image indicates the need of a different treatment. To avoid the trouble of keeping many developers on hand, one may keep besides the regular mixture, one of double strength. When a stronger development is called for, part of this may be added, or when a weaker, the regular developer may be diluted with water, and must at the same time have an addition of acetic acid proportionate to the water added.

The object of the worker with the wet process will always be to secure a very sensitive collodion with a reasonable amount, but not an excess, of intensity, and having found a cotton which with some appropriate salting, will answer this need, he will regulate the development so as to make up for whatever deficiencies the character of his images may tend to show.

§ 3.—Selection of Bases.

The selection of bases to which the iodine and bromine shall be united, is a matter of very great interest to the photographer. And this has been so well recognized that even exaggerated importance has been ascribed to it. The following will, it is believed, be found to be the sum of what is actually known on the subject.

It appears that the most permanent collodions are obtained when the iodine and bromine are combined with only a moderately powerful base. The alkalies tend to provoke decomposition, perhaps by attacking the hyponitric acid contained in the pyroxyline, whereby iodine is liberated, or at least enters into other forms of combination. Of the moderately strong bases, cadmium has been found to give such excellent results that it is very extensively used.

On the other hand, freshly-mixed collodion does not give as good results as that in which certain reactions, little understood as yet, have taken place between the constituents; and these reactions take place much more rapidly when an alkaline base is present. For this purpose *ammonia* is greatly preferred. *Potassium* is liable to the objection that its bromide is comparatively insoluble in the mixture of alcohol and ether used as a solvent. And even if the potassium appears in the form of iodide, yet as a bromide must be employed also, it follows, according to the well-known chemical law, that if the constituents present are capable of forming a combination insoluble in the solvent used, that combination will be formed. Therefore, if with bromide of cadmium we mix iodide of potassium in such proportion that if by the combination of all the potassium with its proportional amount of bromine, there will be more bromide than the liquid present can dissolve, then that excess will inevitably be formed and precipitated.

A grain, or possibly two, to the ounce of bromide of potassium can, however, be kept in solution in an ordinary collodion. To get it dissolved, all the salts should be placed together in a large test-tube or a flask, alcohol be poured over them, and the whole boiled for some minutes. Fresh alcohol is then to be added to the undissolved part, and the operation repeated till complete solution is effected. It should be clearly understood that the bromides of potassium and ammonia are more soluble in

a solution of bromide or of iodide of cadmium than in plain alcohol. They form double salts of greater solubility than the unmixed alkaline bromide. This fact explains why some operators can prepare a collodion partly with potassium, and some cannot: all depends upon the manner of operating.

Much also depends upon the solvents. The less high the grades of the ether and alcohol, the more easily will the bromide of potassium be kept in solution. The writer is much disposed to think that when two grains of this salt are used to the ounce of good solvents, a portion of it is sooner or later precipitated, and if the collodion be used whilst this precipitate is tending to form, *pin-holes* will result.

Sodium forms a more soluble bromide than potassium, and the use of bromide of sodium, or of iodide of sodium, in the presence of bromide of cadmium, has been highly praised, but has never attained general acceptance.

Lithium forms a very soluble bromide, and its use in collodion has been very highly spoken of. Its higher price prevents its being more extensively used. Its action is similar to that of potassium.

A curious difference exists between the actions of alkaline salts and of cadmium compounds in this: that the alkaline iodides and the bromides tend to render collodion thin and fluid, whilst the corresponding cadmium compounds render it thick and viscid.

For the various reasons here given, it is almost invariably customary to combine in collodion and alkaline and a metallic base.

Collodions made for sale must have good keeping properties, therefore in such the proportion of cadmium largely preponderates. Those mixed by photographers for their own immediate use, bear a larger proportion of ammonia, and this composition is generally preferred by portraitists.

Before touching upon the influence of iodine and bromine, which will form the subject of the next section, I must remark here that it is by no means indifferent in what form we add the respective substances to the collodion. It is a general law in chemistry, that when different salts are all completely dissolved in a solvent, the resulting combination will be independent of the form in which the substances were added. For example, if an equivalent of nitrate of potassium and one of chloride of sodium

be dissolved in water, the result will be absolutely the same as if one equivalent of chloride of potassium and one of nitrate of sodium had been used. In each case the affinities are independent of the original form of the compounds.

It would be a great mistake to apply this principle to the preparation of collodion, as some might be disposed to do. The admixture of one equivalent of iodide of ammonium and one of bromide of cadmium would produce a quite different collodion from that afforded by the mixture of one equivalent of bromide of ammonium and one of iodide of cadmium. This is a point that cannot be too well understood.

The explanation is, that bromide of ammonium is a very stable salt, so, likewise, are bromide and iodide of cadmium; but iodide of ammonium is not. As received from the manufacturer it is apt to be yellowish, and to have a penetrating smell, apparently of iodine. It reacts quickly on the collodion and brings it soon to an orange shade, as is observable in collodions made with iodide of ammonium and iodide and bromide of cadmium. Whereas collodions made with bromide of ammonium and iodide of cadmium retain a pale straw-yellow color (if the pyroxyline has been quite neutral) easily for a year, and even more.

Mr. Blanchard has published some remarkable experiments which show the difference of the action of alkaline and metallic bases. He found that in some cases a bath rendered alkaline and exposed to the sun, fogged, and that acidifying only made it worse. If such a bath, showing a decided alkaline reaction, was used to sensitize a film in which ammonium salts predominated, each plate showed less fog, until presently perfectly clean ones were obtained. Under the same circumstances, cadmium collodions gave dense fog, without a trace of an image.

This probably has something to do with the fact that the tendency of late years has been to use less and less cadmium, some even omitting it entirely (see formula 5).

To resume, then. For all practical purposes, ammonium and cadmium are the great resources of photography as bases. Where the bromine is combined with the ammonium, and especially when the proportion of ammonium compound is not over the fourth parts of that of the cadmium, a collodion is obtained which ripens within ten days or a fortnight, and then continues of excellent quality for many months, or, in a cool place, for years.

When the iodine is combined with the ammonium, and especially when this is used in larger proportions than above mentioned, collodions are obtained that ripen rapidly, and are fit for use in two or three days, or even in a few hours; but which become dark colored and insensitive, and give harsh pictures when kept. Whilst these are in their best condition, they are by some considered as giving the best possible results, and superior to those of the other class. It is only, however, when there is a regular and uniform consumption of collodion that this form can be employed without waste, or the risk of having a quantity of material on hand that has passed its best condition.

Collodion which contains an iodide assumes in a few days, often in a few hours, an amber color, whereas collodion made with bromides only (for certain dry processes) remains as colorless as water, or rarely takes a perceptible yellowish shade.

Where it is desired that new collodion shall ripen rapidly so as to be fit for use as soon as possible, it should be kept in a warm room and in a strong light. On the contrary, when it is intended to keep it for a length of time, it should remain in the dark, and in a cold room, best in a cellar.

§ 4.—Effects of Iodine and Bromine.

At first iodides were used alone in connection with collodion. But as photographers were familiar with the influence of bromine, bromides were shortly after used with collodion. Experience led (by surprisingly slow degrees, however) to the recognition of the fact that they were invaluable.

The manner in which bromides act is, however, still a point not thoroughly settled. It is a familiar fact that iodide of silver *solarizes* very easily, that is, the maximum effect of light is quickly reached, after which its action is reversed. So that with a certain degree of exposure, for example, the brightest lights may produce less impression, and come out in the development less strongly than others of inferior intensity. Bromide of silver has much less of this tendency, and a collodion containing bromide has much less tendency to solarize.

It has also been generally held that the use of iodides was favorable to the effects of force and contrast, whilst bromide tended to softness and the correct rendering of half tone.

Some careful experiments made by the writer brought him to

the conclusion that this view requires a certain limitation, for that when bromides were added to collodion in large excess, that collodion used in the wet process, gave harsh pictures, so that softness of effect and correct rendering of half tone depend upon the judicious combination of the two. For example, two grains of bromide and four of iodide gave a soft and well-modelled picture. More bromide was found to make the picture too soft and deficient in contrast, up to a certain point. Then the contrary effect set in, and when four grains of bromide were used to two of iodide, the picture was harsh.

Another important function of bromide of silver is that of keeping the plate clean. It is certain that a bath which will no longer work with a pure iodide collodion, will give good pictures with one containing bromide. So with careless manipulation and impure chemicals, clean pictures may be got with a collodion containing bromide, when this would be impossible with a simple iodide collodion.

In the older formulæ employed for collodions, a great variety of substances were employed, and in some not only iodides and bromides, but also chlorides and fluorides. Then came a tendency to reject everything but iodides. Next this was modified by introducing bromides, and it is by no means impossible that we may yet find it advantageous to introduce a portion of chloride into our collodions.

The writer expresses this opinion, not with any positiveness, but as an idea which we may yet see realized. He has made many experiments on the development of positive prints on paper, and has been much struck with the superiority of chloride for this purpose. He believes that, at least when he first published this view, it was contrary to the prevailing opinions, according to which mixtures of iodides and bromides were preferred. But he found chloride of silver, though less sensitive and needing a rather longer exposure, to work far more evenly and regularly than the others, and he has little doubt that a grain, or perhaps half a grain to the ounce of chloride of copper, would be found an improvement. A collodion containing three grains of chloride of copper, ten of bromide of ammonium, and twenty-five of iodide of cadmium, to two and a half ounces each of alcohol and ether, and twenty-five grains of pyroxyline, would constitute a collodion which would probably be found to have superior qualities.

(Since the foregoing was written, the writer has shown that a perfectly invisible image upon chloride paper can be perfectly developed with as full detail as one upon bromo-iodized paper. And that the use of chloride of silver in connection with bromide in a particular form of dry process (chloro-bromide process) gives most excellent results.)

Experiments made by the writer with collodion containing a *chloride* and a bromide in equivalent proportions, resulted in showing that such a collodion gave faint images and foggy plates, with a bath working well with ordinary collodions. He concluded, therefore, that an *iodide* is an essential constituent of collodion for the wet process, at least with baths as used at present. Herein is a remarkable distinction between wet and dry processes. On the other hand, neither chlorides nor bromides are essential to the wet process, but good plates may be obtained with iodide of silver alone, or in connection with either bromide or chloride of silver.

By some it has been argued, that the beneficial effects of the addition of bromide of silver are due to the fact that, as has been stated, bromide of silver is sensitive to less refrangible rays than iodide. That whilst iodide of silver was affected by only the violet and bluish-violet rays, the bromide was sensitive to the blue, and even, to some extent, to the green.

The writer pointed out, as far back as 1865, that the action of the green color of leaves upon the collodion film was very trifling and of little importance, and that leaves impressed themselves upon the film, not by the agency of their green, but of their white light.

In bodies generally we distinguish two sorts of light as emanating from them. One reflected from the surface, which is white, whatever be the color of the body, and the other emanating from the interior of the body, which is characterized by color. In some cases one of these may predominate almost to the exclusion of the other. Perfectly black objects send us only surface light, and in perfectly white objects the interior color is white as well as the surface color.

Now this surface light, which we scarcely take into account at all in our ordinary observation of bodies around it, so completely is it masked by the colored light, is, in fact, as the writer has elsewhere pointed out,¹ all that is really effective to the photographer,

¹ *Philadelphia Photographer*, July, 1867.

with the exception only of blue or violet-colored bodies. All bodies of blue-green, green, yellow, orange, and red colors impress themselves on the collodion film *solely* by virtue of the white surface light that accompanies, unperceived to us, the colored emanations which they give forth.

It follows from this that there is little use in endeavoring to find collodion that has a little greater range of impressibility. What we want is a film sensitive to the very faintest rays of white light, so that every faintest emanation of surface light shall act upon it by virtue of the violet rays which it includes. This high sensitiveness is rarely accompanied with a great intensity, so that it is precisely the most sensitive collodions that are most apt to need a redevelopment.

Vogel has published some interesting experiments, from which he concludes that iodide of silver is more sensitive to strong lights, is more quickly impressed by them than bromide, but, on the other hand, that bromide is more sensitive to weak rays. Schrank and others have since called this view in question. Schrank gives as the result of special experiments made by him, that the beneficial influence of bromide depends upon its absence of tendency to solarization.

In view of this diversity of opinion, and still more, of the influence of the pyroxyline itself, it is not surprising that the relative quantity of bromide to iodide, which gives the best result, is still unsettled. It has been positively ascertained that the bromide should not form less than 20 nor more than 50 per cent. of the whole salting. It may be said, however, that the proportion of bromide recommended has steadily increased for several years past, and with its increase has been a well-marked gain in the artistic effect of the photographs produced. The addition, moreover, of bromide has the effect of rendering the process far more certain. The bath will continue to work with a well-bromized collodion long after it has ceased to give any good result with a simply iodized collodion. The tendency to stains, fog, and other troubles in development is far less with a bromo-iodized collodion. On the other hand, too much bromide leads to the production of flat and monotonous pictures, unless, indeed, the proportion of bromide be very much exaggerated, when the result again becomes too harsh. Too much bromide also tends to give a granular crystalline precipitate wanting in fineness.

It now remains to give a few general directions as to the preparation and management of collodion, and then will follow some of the best formulæ in use.

To make the collodion, the cotton should first be weighed and placed in the bottle. Three-fourths of the alcohol are then to be added, and shaken up with the cotton. Next the ether is added, and the whole shaken till the cotton dissolves. If the cotton is exactly right, little or no visible residue will be left—a few filaments through the liquid, which, however, will not be clear.

This constitutes *plain collodion*, which may either be kept as such, or at once be sensitized (which is the better plan) by dissolving the salting in the remaining one-fourth of alcohol.

In preparing a collodion, the photographer will always be guided by the purpose for which it is destined. It is true that collodions can be made which will answer well for almost any use; but not so thoroughly well as a collodion especially intended for that particular employment.

Thus for portraiture there is a general preference given for collodions containing from one to two grains of a bromide. Here the main object is rapidity and delicacy. The light is under almost complete control by the shifting of blinds and shutters, and harsh contrasts can always be avoided by that control.

With landscapes the case is very different. We take the light as we find it, and must enable ourselves to control our chemicals. Collodions suitable for portraiture would give excellent results in landscape work in dull weather, but in bright there might with some be difficulty in getting harmonious effects. These we secure by increasing the bromide, if the collodion in question be deficient in it. Where the contrasts constitute the main difficulty, as in taking interiors of buildings, or copying old paintings, the proportion of bromide may be increased to one-half. The writer proved some time ago that if we go beyond this point, in place of obtaining a still farther increase of softness, a contrary effect sets in, and we get increase of contrast.

A difference will also be made in the formula, according as the collodion is needed for immediate use, or can be put aside for some time to ripen.

Formula 1. *Portrait Collodion.*

For immediate use.

Alcohol and ether, equal parts	1 ounce. ¹
Iodide of ammonium	5 grains.
Bromide of cadmium	1½ to 2 “
Pyroxyline	6 “

This collodion can be used as soon as it assumes a straw-color, or immediately, if a little tincture of iodine be added.

Formula 2. *Portrait Collodion.*

To be kept for several months before using.

Alcohol and ether in equal parts	1 ounce.
Bromide of ammonium	1½ to 2 grains.
Iodide of cadmium	5 “
Pyroxyline	6 “

Formula 3. *Portrait Collodion.*

To be kept six months in a cellar before using.

Alcohol and ether, equal parts	1 ounce.
Bromide of cadmium	1½ to 2 grains.
Iodide of cadmium	5 “
Pyroxyline	6 “

The tendency to the use of the more rapidly ripening collodions made chiefly with ammonium (Formulas 1, 4, 5, 6) rather than the slower ones in which cadmium preponderates (Formulas 2, 3, 8), seems to be on the increase, though, many good workers still prefer the more stable sorts. Collodions, like No. 3, if kept in a cool place, are good in six months, better at a year, and still good at eighteen months.

In addition to the foregoing the writer gives the collodions of some of the most successful portraitists in various countries.

Formula 4.² *Reutlinger (Paris).*

Ether	6 ounces.
Alcohol	4 “
Cotton	50 to 60 grains.
Iodide ammonium	30 “
“ cadmium	20 “
Bromide of ammonium	5 “

¹ It is important to understand that in these and all other photographic formulæ the ounce means a *fluidounce* as *measured in a graduate*, and never a weighed ounce. The expression is evidently an incorrect one, but its use is universal. See also foot-note to p. 126.

² This formula calls for the addition of “a little pure sodium.”

Formula 5. *Sarony.*

Ether and alcohol, equal parts.	
Iodide of ammonium, to ounce	4½ grains.
Bromide of potassium “	2 “
Pyroxyline	5 to 7 “

The pyroxyline to be treated with ammonia. (See Sec. 2 of this chapter.)

Formula 6. *Gurney.*

Ether and alcohol, equal parts.	
Iodide of ammonium, to ounce	5 grains.
Bromide of cadmium “	1½ “
Bromide of ammonium	1¼ “
Pyroxyline	5 to 7 “

Nos. 1, 4, 5, and 6 work best when from ten to thirty days old.

Formula 7. *Landscape Collodion.*

Alcohol	15 ounces.
Ether	15 “
Bromide cadmium	35 grains.
Iodide “	80 “
Bromide ammonium	30 “
Iodide “	60 “
Pyroxyline	180 “

This ripens more rapidly than the following, in consequence of containing iodide of ammonium.

If softer effects are desired, the bromide may be moderately increased, but too much of it will result in flat pictures and a coarsely grained deposit.

Formula 8. *Landscape Collodion.*

To be kept some weeks, or else mixed with other ripe collodion.

Alcohol and ether, equal parts.	
Bromide of ammonium	2 grains.
Iodide of cadmium	4½ “

The sensitizing is done by placing the weighed salts in a test-tube for small quantities, or a flask for larger, and pouring over them the remaining fourth of the alcohol, not at once, but in successive portions, allowing each to take up what it will before pouring it off. It is generally expedient to employ the heat of a

Bunsen burner or spirit lamp to get the bromide into solution. It is not worth while to filter the solution—the simplest plan is to pour it into the plain collodion, shake well, and filter or decant afterwards.

Bromide of cadmium dissolves very easily in alcohol; bromide of potassium and of ammonium, with much difficulty. But these alkaline bromides dissolve much more easily in a solution containing already bromide of cadmium (because double salts are formed, whose solubility is greater than that of the alkaline salt). Therefore it will always be found easiest to place all the salts together in the test-tube or flask and dissolve them together.

Great care must be taken of fire, in all operations with ether which may readily ignite from a flame at a considerable distance. Ether evaporates very easily, and its vapor rapidly spreads through the atmosphere—this vapor may easily become dense enough to carry the flame. For this reason the *utmost* care is needful, and accidents with the heedless are very common. The danger is all the greater that as ether has little affinity for water, water does not easily extinguish it, the ether floats on the surface and continues to burn. *Wet sand* is the best application. If a quantity of ether is spilled by the breaking of a large vessel, the first care should be to extinguish every light and fire in the building. The next to provide buckets of wet sand, in case of kindling. If happily this is avoided, no fire or match should be lighted until the whole house has been so thoroughly ventilated that the smell of ether has disappeared.

Many operators regularly add a little solution of iodine to all their collodion, and there is no doubt that that system is the one that obviates the most completely all danger of fogging. Others prefer to depend upon the aging or ripening of the collodion.

Those who adopt the former plan of adding iodine to the collodion, should be extremely careful about acidifying the nitric bath. Perfectly neutral nitrate of silver should alone be employed, and before adding *any* acid to the bath, a plate should be tried with the collodion intended to be used, and if it works cleanly, then *no acid* must be introduced into the bath, or the sensitiveness of the film will be materially diminished. This point will also be adverted to in the remarks on fogging.

A collodion that gives a thin image will often be cured of this

defect by adding to it pyroxyline in the proportion of a grain or two to the ounce. On the other hand, coarseness indicates the presence of too much pyroxyline.

§ 5.—Clearing Collodion.

When time can be given, the simplest and much the best method of clearing collodion is by subsidence and decantation. The collodion is set aside for any time not less than a month, and the clear part poured off. It will be found, however, that the operation of pouring quickly stirs up the sediment at the bottom, consequently the method of transferring represented in Fig. 90 should invariably be employed. Two holes are pierced through a cork, one carries a short bent tube A, and through the other is passed the shorter leg of the siphon S. By blowing gently into the tube A, the siphon is started, and then continues to empty the bottle to the level of the bottom of the shorter leg. This last should be pushed down to within a quarter of an inch of the layer of sediment.

At B is represented the size and weight of glass tube which will be proper. The siphon is easily made by bending the glass tube over a bat-wing gas-burner: heavy tube, though slower in heating, is much more manageable than light. The cork should be very conical, in order that it may fit any size of neck for which it may be wanted.

If filtering be resorted to, then instead of the filtering apparatus commonly employed, in which the collodion is filtered through sponge, the writer has found it far preferable to select a piece of fine strong close-woven linen. This is thrown into boiling water and left to soak for some hours to get rid of the dressing; it is then well shaken in cold water and dried. A round piece about four inches in diameter is cut. As the collodion runs through in a rapid stream, this will be large enough.

By preparing a yard or two of linen in this way, the photographer will be supplied for an indefinite time; for one piece

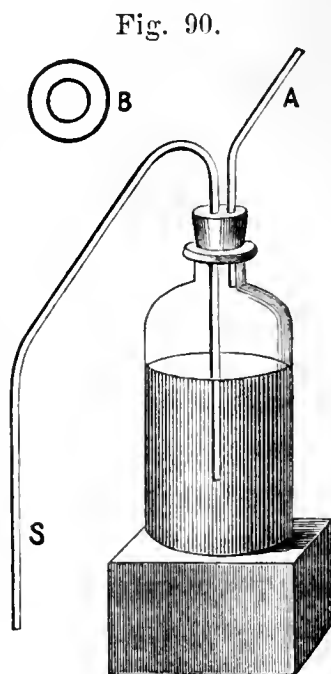
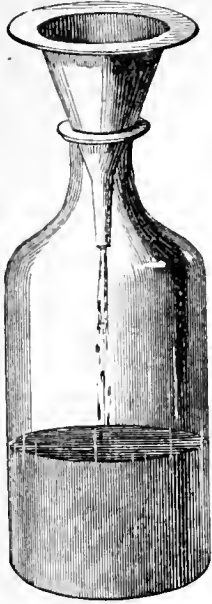

Fig. 91.



answers over and over again. Although it may appear to have its meshes completely stopped by the solidified collodion, still it filters as well as ever.

Sponge is also excellent for filtering collodion. The writer takes "surgeons' sponge," or even a fine quality of carriage sponge, and soaks it for two or three days in hydrochloric acid diluted with eight times its bulk of water, using plenty of the dilute acid. This removes the calcareous matter, and renders the whole texture of the sponge weak and soft. It is then *thoroughly* washed out with water, dried, and is fit for use.

Whichever is used, the funnel should be covered with a plate of glass, as shown in Fig. 91. With this precaution the evaporation becomes inconsiderable.

§ 6.—Keeping Collodion.

The ripening of collodion depends upon *temperature*, and, probably, to some extent upon *light*. If, therefore, it is desired to ripen collodion rapidly, it should be kept in a warm light room. On the other hand, if a quantity is prepared to be used over a long period, it should be placed in a cool dark cellar. Collodion chiefly salted with cadmium salts keeps well and improves for a long time.

It is well to understand that with time all collodions tend to produce a substance having a peculiarly irritating odor, which sometimes causes personal suffering to those that use it. Especially it attacks the eyes, and cases have been known of persons obliged to give up photography for six months or a year, so obstinate is the soreness produced in this way.



CHAPTER IV.

THE NEGATIVE.

§ 1.—The Camera.

THE photographic camera should be made of mahogany or cherry, not of walnut, should be neatly fitted, and strongly put together. Small cameras are often fitted up with a removable partition, so that they can be used either with two lenses for stereos, or with a single lens. The front of the camera should permit of a movement up and down, and sideways, in either case to be arrested and the front held firm, by a mill-head screw. This is known as a *Sliding Front*. The focus is regulated in two different ways, the camera front is racked in and out by a long screw moved by a mill-head at the back, or the back is moved in and out by a mill-head that turns a pinion working in a rack. In the latter construction a "pinching screw" serves to secure the position firmly when the focus has been taken. Every camera should have a "universal level" set in, to enable the operator with certainty to level his instrument. The universal level is about an inch and a quarter in diameter, and contains a piece of glass ground to a slight curvature somewhat like a watch-glass. A single bubble of air in the spirit underneath, indicates a true level by resting in the centre of the glass. This level is inserted in the camera at the back, just behind the ground glass. Those who have cameras unprovided with them, can procure them at a small cost from makers of surveying instruments (the writer's were made by Mr. Zentmayer, Fourth St. and Harmony Court, Philadelphia). To insert them a board must first be fixed in a perfectly level position. A hole $\frac{1}{8}$ inch deep must previously have been made in the camera for the level. The camera is set upon the accurately levelled board, the level is then so set into its cavity that the bubble will be in the centre. A little cap cement or bottle wax serves to secure it permanently.

The *landscape camera* should be lightly but strongly made of the best seasoned mahogany, walnut being too apt to crack, and

should combine lightness for carrying, with solidity. Brass bindings will be useful, by permitting the wood to be lighter.

Although most views require that the greatest dimension of the plate should be horizontal, still there are very many cases where this condition can be advantageously reversed, and, therefore, it is *essential* that the camera shall be arranged to screw on to the tripod in either position. *There is only one way in which this can be properly done*, that is, by having a wood or metal cross-piece, as represented in the figure. That shown in Fig. 92 is of wood. When brass is used, it may be much narrower, but needs a third arm extending from the screw-hole A to the front part of the base at C. (See Fig. 94.)

Sheet brass is wholly unsuitable. A careful brass casting is needed, which must be stout and stiff.

Fig. 92.

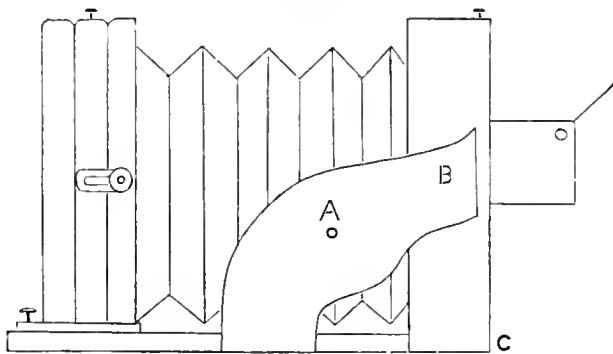

If wood be employed, nothing will be suitable except the best mahogany. The screw-plate must be set on the *inside*, if set on the outside it will soon be pulled off.

After having given both a fair trial, the writer prefers the wood, especially for large cameras.

In cameras made for sale, there will often be found, instead of a cross-piece a simple screw-hole at B. It is evident that the strain resulting from actual use will be so great as either to soon pull the camera to pieces, or force it out of shape. On the contrary, the arrangement here described adds materially to the solidity of the instrument.

The Swing-back and Swinging Lens.—The swing-back is the most capital improvement to the camera that has ever been made. Its object and mode of use should be fully understood, and when once mastered, this contrivance will be accepted at once as an indispensable adjunct to both landscape work and portraiture.

The swing-back has two objects perfectly distinct from each other. The first is—

To render it possible to tilt the camera and yet avoid distortion of vertical lines.—In making a view of any building, we are apt to find that we get too much foreground, whilst the upper part of the building is apt to be beyond the edge of the plate. To some extent we can remedy this by pushing upwards the sliding front of the camera. But this is insufficient, and is open to the serious objection that as the axis of the lens no longer coincides with the centre of our picture, we no longer get the best definition of the lens. So that only a little adjustment is allowable in this way. And if we tilt the camera upwards all the vertical lines of the building are intolerably distorted.

The remedy is as follows: Let E F represent a vertical line in any building. If we tilt the camera so as to get the whole of it upon the plate, the plate will occupy the inclined portion A B, and the lines will be distorted. But if we can shift the back so that whilst the camera is tilted, the plate can be kept in the vertical position C D, and remain parallel to E F, then there will be no distortion, however much we may tilt the camera.

Fig. 93.

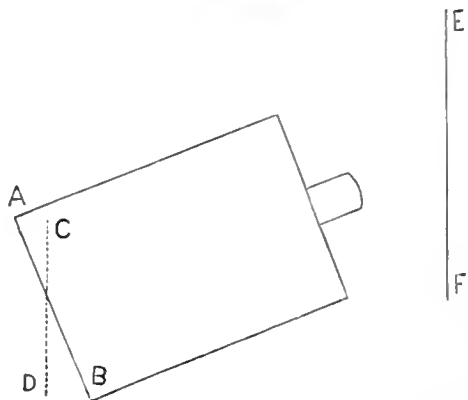

This result is obtained by sawing through the back of the camera and interposing a few bellows folds. At a point about half way between the top and bottom

Fig. 94.

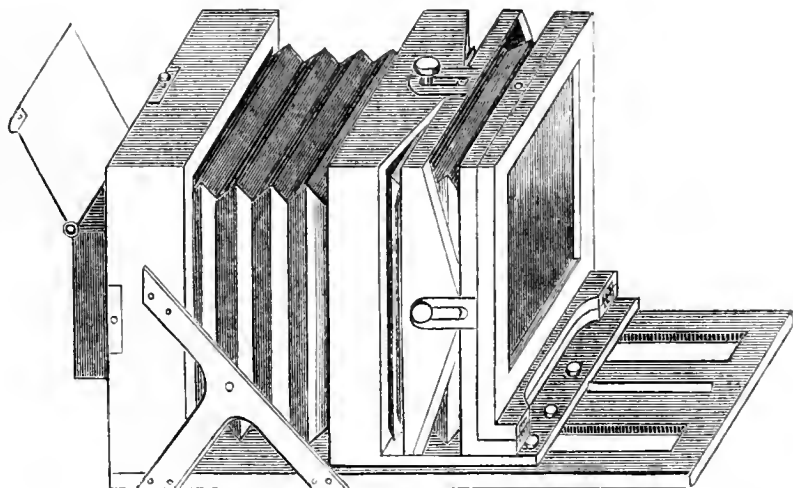

there is a pivot on each side, on which the back swings, and on the top there is a brass slot and a mill-head which secures the swing-back firmly into any position that has been given it.

This arrangement is, however, incomplete without a second piece exactly similar, but with its pivots at top and bottom, and slot and mill-head at sides. As the first described permits the plate to be adjusted *vertically*, it will be called for distinction the *vertical swing-back*. And as the second, that with its pivots at top and bottom, moves horizontally, it will be called the *horizontal swing-back*. The two together constitute the "double swing-back," and is represented in Fig. 94.

The second and perhaps the most important function of the swing-back is to *aid in getting different parts of a subject simultaneously into focus*. It is evident that with a double swing-back, the different portions of the plate may be made to assume a great variety of positions. Either the top, the bottom, or either side may be brought nearer to the lens, or farther from it than the centre.

Use of Swing-back in Portraiture.—Often the camera needs to be depressed in front to make it conveniently include the whole of a standing figure. Here the first-mentioned application of the swing-back comes in, and vertical lines, as columns, windows, &c., are preserved from distortion. The second application of the swing-back finds its use with sitting figures, in which the feet are always too near for the rest of the body, and with lenses of long focus it will not be easy to get them into focus with the face. Being *nearer* to the lens, they will have a *longer* focus. We have, therefore, only to move the vertical swing on its pivot so as to draw the top of the plate back a little, and the difficulty disappears. For this purpose the pivot A should be *below* the middle, in order to be opposite to the head, it being an object in adjusting the swing-back not to disturb the focus on the principal object, but this point is apt to be overlooked by the makers. (For landscapes, the pivot is best exactly in the middle.)

The horizontal swing-back will be useful in taking groups, and permit of varying the grouping in a way otherwise impossible with a portrait lens. With its aid, the members of the group at one side may be nearer or more distant than those at the other: may be more distant than the central ones, and yet may be got into focus by bringing the end of the plate upon which they fall nearer to the lens.

Landscape Work.—For landscape work the swing-back is very valuable in several ways. In almost all views the foreground is the nearest portion to the camera. Its conjugate focus is longer, consequently if the focus is taken so as to embrace satisfactorily the rest of the picture, the foreground is apt to be wrong. And if the focussing slide be racked back to bring the foreground into correct focus, the rest of the picture suffers materially. The evil here spoken of is often considerably alleviated by *curvature of the field*, but yet not often sufficiently, and in lenses possessing a flat or nearly flat field, even this assistance is wanting. It is therefore an immense aid to be able to move the top of the plate a little away from the lens.

There is yet another use for this valuable contrivance. It will occasionally happen in landscapes that *one side of the view is materially nearer to the camera than the other*. Here the horizontal swing-back comes into play. The side on which the nearer objects fall is pulled a little out from the lens, and that part of the picture comes into focus without material injury to the centre.

The combination of these two movements, vertical and horizontal, will sometimes be valuable, and it is moreover to be observed that as the camera is used sometimes on its base and sometimes on its side, the functions of the two swing-backs change with this change. When the camera is turned upon its side, that which was before the horizontal swing-back now serves to regulate the foreground. So that whatever value is placed on the two modes of adjustment, neither can be dispensed with, exchanging functions as they do. It is, therefore, a serious mistake to purchase a camera with a single swing-back, except, perhaps, in the case of a camera to be used solely and exclusively for stereoscopic work. In this case a vertical swing-back (with pivots at the *sides*) is principally needed.

Swinging Lens.—A little consideration will show that results analogous to the above may be obtained by simply so setting the lens that it may turn freely in all directions. The writer considers, however, that the introduction of this system as a substitute for the swing-back, is a serious evil. Before explaining this, it will be proper to exhibit the action of the swinging lens.

Suppose that the tube of the lens L be jointed to the camera

so that it can be turned in any direction whilst the body of the camera remains fixed. It is evident that the focussing screen A B, and consequently the sensitive plate *remains vertical*, precisely as if the lens had not moved. And remaining vertical it cuts the cone of rays from the lens, parallel to the vertical lines of any building that may stand before the lens. These are, therefore, correctly represented on the screen A B, precisely as if the lens L had remained in the ordinary position.

Fig. 95.

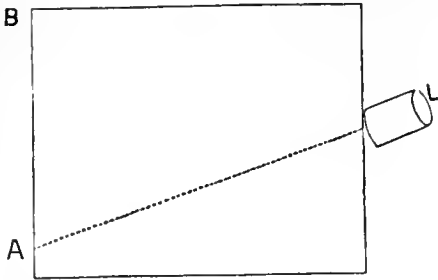

But the tilting of the lens, whilst it enabled the camera to take in the higher parts of any building before it, at the same time altered the position of the axis of the lens. This axis when the lens is in its usual position, passes through the centre of the camera, but with the tilting assumes a new position L A, and the centre of the image no longer corresponds with the centre of the focussing screen, but falls to A.

To remedy this the camera front, carrying with it the lens, is raised until the axis of the lens takes the position B L (Fig. 96).

Fig. 96.

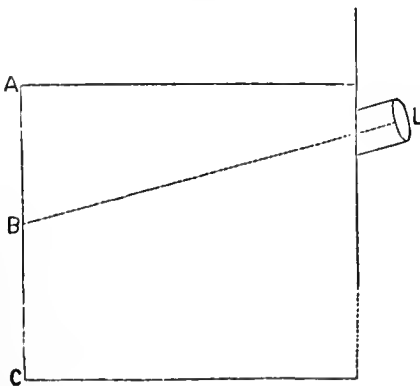

So that here we have accomplished much the same result as by the swing-back, viz., we have tilted the lens so as to embrace the higher objects and yet have kept the image perfectly vertical. With the swing-back the centrality of the axis was not disturbed, here it has been disturbed, but readjusted.

For this object, the utility of the swinging lens is probably equal to that of the swing-back.

Next, as to adjusting the focus for the foreground. It is to be remembered that the image is formed at *right angles to the axis of the lens*, consequently when the lens is bent downward and the axis takes the position L A (Fig. 97), the image is found in the plane B C. But this image is not received on the focussing screen at the position B C, but in that of D E. A little reflection will show that this change corresponds with the moving back of

the swing-back. That is, that in both cases the image is received on a plane which, at the top of the camera, is *farther from the lens*. And thus in both cases, the longer focus of the foreground will be accommodated.

Fig. 97.

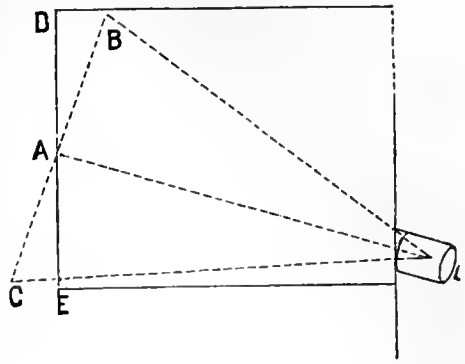

It is evidently a fault in the swinging lens that thus to bring the foreground of a landscape into focus we are obliged to tilt the camera downwards, and so take in *more* foreground. But this again can be cured by tilting the body of the camera upwards. Let us say that we first arrange the camera in such a position that we include just what we want, and have the horizon line where we want it. But the foreground is not in focus. We therefore first turn down the lens somewhat, and then tilt the camera upwards until this tilting brings the lens into its first position. It is therefore certain that the swinging lens can, like the swing-back, accommodate the focus of the foreground.

But its great inferiority lies in the *way* in which this is done. With the swing-back we arrange the camera with the largest opening of the lens until we get the picture exactly composed, and then changing the diaphragm as the case may need; if the foreground is not in focus, a slight adjustment of the top of the plate brings it right.

With the swinging lens we have a double adjustment to make. First, the lens must be depressed. We cannot tell, however, how much, but can only make a trial, then the camera is to be tilted, the horizon line readjusted, and we examine if the proper amount of change has been hit upon. If the foreground is not yet in focus, or if, in getting it into focus, we have seriously injured the focus of any other part, in either case the manipulation must be tried over again. Whereas with the swing-back, we watch the changes and stop it exactly at the proper point. And a similar objection holds where these contrivances are used to meet the case of the two sides of the picture being at different distances from the lens. Here also the adjustment with the swing-back is the easier.

§ 2.—**Selecting the Glass.**

None but very careless operators will use a lot of glass indiscriminately. Every piece should be gone over and examined previous to cleaning it. The high price of plate glass in this country almost wholly excludes it from photographic use. If it could be obtained at the same cost as in England, France, or Germany, none other, or very little other, would be used. As it is, photographers for the most part content themselves with a quality of glass, usually of French manufacture, known as "photographic glass."

The best quality of the glass only should be purchased. It comes in boxes containing fifty square feet. Opening such a box, and sitting with his face to a well-lighted window, the operator examines every piece—

1. *As to sufficient thickness.* Thin plates break too easily in the printing process.

2. *As to curvature,* by running the eye along the edges: a slight curvature cannot always be avoided; but anything over a certain degree of bow is a sufficient cause for rejection.

3. *As to blebs.* In sun printing these are apt to show, and it is generally safest to reject all plates that exhibit this defect, as it is difficult to foresee how much injury may result from it.

4. *As to scratches.* Some lots of glass by careless handling will be scratched. All pieces with scratches visible by transmitted or reflected light are to be rejected. And to avoid farther danger every piece after examination must have a sheet of paper laid between it and the adjoining piece. And this precaution must be kept up in every subsequent stage of the operations. Printed paper should never be employed for this purpose, but some common though clean sort. If glass is left for some time in contact with printed paper, a complete impression will be taken off upon it, and the difficulty of cleaning will be proportionately increased by the greasiness transmitted to the glass.

5. *As to surface.* Some pieces of glass must be rejected for roughness of the surface.

A close attention on the part of photographers to these points would have the effect of obliging those who manufacture photographic glass to work more carefully and deliver a better material.

Preparing the Glass.—The cleaning of the glass has already been explained in the introduction. A system has latterly gained ground a good deal, of *albumenizing* the glass, and thus obviating the necessity of being very particular in the cleaning. Some simply take white of egg and shake it up with twenty times its bulk of water, in a bottle with sharp fragments of glass, filter it, and make fresh for each day's use. Others mix the white of egg with an equal bulk of water and a little liquid ammonia, a fluidrachm for a dozen eggs. In this condition it keeps, and can at any time be used by diluting it with an ounce of water to each drachm of albumen.

Some prefer to iodize the albumen, obtaining in that way rather more brilliant points—2 or 3 grains to the ounce of diluted albumen will be sufficient. The albumen is to be extended over the plate with a glass rod (by some a piece of pasteboard is preferred), the excess poured off, and the plate reared up to dry.

As the cleaning of glass cannot be wholly dispensed with, the writer does not see that any sort of cleaning involves less trouble than the method with bichromate. And when that is done properly, anything further is altogether superfluous. The writer has in some of his experimental trials in dry work used the same plates over and over until the marks made on the back with a diamond pencil indicated that they had been used 5, 6, or 7 times each. And never on these or any other occasions has he seen indications of imperfect cleaning or the reappearance of a previous image.

§ 3.—The Negative Bath.

The course of proceeding recommended in the introductory portion of this manual involved the use of a single bath of moderate size. This is the best course for the beginner, because he will inevitably spoil some of his first baths, either by introducing foreign substances into them, or by mistaken treatment with the view of improving them. But when he has attained a certain familiarity with photographic operations, he will do best to adopt the *two-bath system* originally proposed, I believe, by Mr. Wharton Simpson. In this mode of operating, one bath serves to form the sensitive film and receive the alcohol and ether; the second bath furnishes a nearly pure silver solution, moistening the film and serving for development.

The writer prefers to make these baths of widely different strengths. The first bath is made strong, 40 grains to the ounce, because the stronger the bath the more completely the iodide and bromide remain in the film. The second is made comparatively weak, 20 grains to the ounce. This furnishes an ample supply of silver for development, and the danger of stains is materially lessened.

Moreover, the writer advises ample baths—one size larger than the largest size of plate habitually used, and not in any case less than 60 ounces each.

The advantages of the system of working with two abundant baths are so great that no one who has fairly tried it will ever voluntarily use any other. They consist in extreme regularity of working over a long period, so that the photographer runs little risk in being deceived in his exposures, in unusual facility in obtaining plates of the right density without the annoyance of redevelopment, and in almost complete immunity from stains, marbling, pinholes, &c. &c. The system is, moreover, an economical one. The impurities are concentrated in the first bath for a long time, and when at last the working ceases to be satisfactory, it is put into the residues and the second receives additional 20 grains of nitrate of silver per ounce, and takes its place as the first bath with a new second bath.

The mode of making a bath, and of curing a propensity to fog has been explained in the introduction. It remains to be said here, that although the introduction of iodine into the bath, by working with a collodion to which it has been added, tends to acidify the bath, yet the effect of the two treatments upon the working is entirely different. The writer has known a case of fogging, which could not be cured by any amount of acidification of the bath, give way immediately under the addition of a little iodine to the collodion. It appears from experiments of Weltzien that iodine liberates hyponitric acid (not nitric) from nitrate of silver, and Reynolds ingeniously remarks that as hyponitric acid by action of water splits up into nitrous and nitric acid, it is probably to the production of the nitrous acid that the curative influence of the iodine is due.

Be this as it may, it is certain that if, after a very slight addition of nitric acid to the bath (1 drop to 20 ounces of bath), there appears a disposition to fog, it is far better to add iodine to

the collodion than to go on acidifying the bath. This it is important for the photographer to bear steadily in mind. Also that a bath that fogs badly with collodion in which cadmium salts predominate may not improbably do well with a collodion chiefly salted with ammonium salts.

The nitrate of silver should be perfectly neutral. Most persons prefer the crystallized; the writer has generally used the *fused* in preference. Crystallized nitrate¹ can be converted into fused by melting it in a Berlin porcelain basin over a Bunsen's burner; it should be kept in fusion for a time proportionate to the quantity—five minutes for several ounces, and for quantities of one or several pounds, ten minutes. It is allowed to cool in the basin, and removed by inverting the basin upon a sheet of letter paper placed on a board, the board is then tapped on the back of a chair, and the jarring loosens the cake without breaking the basin.

A negative bath may by careful treatment be used for a wonderfully long time. The writer has been informed by a professional photographer that he had made considerably over 2000 negatives, many of them 10×12 size, in two 4-gallon baths, and had them both still in excellent order. When they ceased to give good results he added carbonate of silver, boiled down, filtered, sunned well, filtered again, acidulated and strengthened.

When the bath gives *pinholes* it must be poured *into* its own bulk of water, filtered, and *after* filtering, be evaporated down to its original bulk.

The writer, in working the wet process, has generally adopted the principle of not wasting time and patience in trying to bring faulty baths into working order, but had made it a rule to substitute a new bath, putting the old one aside until a proper quantity collected. These are then to be evaporated down in a large basin, large enough to hold perhaps a fifth at a time, of the whole quantity. As fast as the liquid goes down, more is added. When the liquid becomes small in bulk, it is transferred to a smaller basin of first quality Berlin or Meissen porcelain, and heat applied until all the water goes off, and a powdery mass is left. The heat is then carefully raised till the whole mass passes

¹ One hundred and eight parts of pure silver correspond to one hundred and seventy parts of nitrate. The mint value of pure silver is \$1 40 in silver, per troy ounce. Metallic silver is sold by the troy ounce (480 grains), nitrate of silver by the ounce avoirdupois (437½ grains).

into quiet fusion, in which condition it is kept five or ten minutes, not longer. After cooling, the cake of nitrate is broken up and used for new baths, acidulating with dilute nitric acid if necessary.

Some, before evaporating, dilute largely with water to throw down the iodide. This makes an immense mass of material to evaporate, and in the writer's experience, has not been necessary. If when the fused cake is dissolved, hot water is used, and the solution filtered at once, most of the iodide will remain undissolved. The full quantity of water needed for the bath should be added to the cake at once, and not a strong solution first made and then diluted.

A second bath, in first-rate order, should always be kept on hand to avoid the need of hurriedly treating a bath that has ceased to work well. The plan of having a second weaker bath to redip the plates after the first, already described, cannot be too much recommended.

Swinging Bath.—In the ordinary dipping bath, if any scum forms on the surface of the liquid, it is apt to settle on the plate as the latter is lifted *face upward* on the dipper. This may be avoided by swinging the bath on pivots half way up. The plate is put in, with the bath in its regular position, the bath is then swung forwards until the plate tips over with its front upper corners on the other side of the bath. In this way when worked up and down, the face of the plate is continually washed, and when drawn out, the scum attaches itself to the back of the plate instead of the front.

§ 4.—Making the Plate.

The mode of coating the plate has been already described and illustrated with explanatory figures. (See p. 22.) In the first edition of this manual, the course habitually taken by photographers in coating blown glass, viz., to coat the hollow side, was recommended. The reasons in favor of this course are, first and principal, the curvature of the field exhibited by many lenses, and secondly, that when the hollow side is coated the pressure of the spring of the dark slide acts to some extent as a corrective, flattening the plate.

Continued experience inclines the author to believe that this system cannot always be advantageously employed, but that in a considerable number of cases, the reverse is the proper plan.

In most landscapes the most distant objects occupy a position towards the centre of the plate; the objects occupying the sides are mostly, and those occupying the lower edge are almost invariably, nearer to the camera than the central objects. It, therefore, follows that the central objects will be apt to have a focus shorter, often considerably shorter than those occupying the margins of the plate. This fact every practical photographer will have very often noticed. And if this is so, it is clear that whatever difficulty there may be in bringing these parts simultaneously into focus upon the ground glass, the case will be yet worse on the sensitive plate if coated on its hollow side, whereas if it be coated on the convex side, the centre of the plate will approach nearer to the lens, and consequently tend to remedy the defect.

It we apply these principles to photographic subjects generally we shall conclude that when the different objects included in the pictures are *nearly in the same plane*, we should coat the hollow side. Therefore in portraits, and in views of architectural subjects, the hollow face should be coated.

On the other hand, when landscapes are to be taken, with the central objects farthest, it will be best to coat the convex side.

In some landscapes the nearest objects are at one side, and as we pass towards the other side of the plate they continually increase in distance. This is not a common case, and is to be managed by the use of the swing-back, drawing back that part of the ground glass upon which the nearer objects fall.

To the remarks already made in Part I., the following may be added:—

Pneumatic Holders.—These are of two sorts; the one intended for collodionizing with, is made entirely of rubber. If the cup portion be wetted and pressed firmly against the glass at the middle of the back, it adheres and affords a convenient handle. Some have a hollow chamber below (see Fig. 98), by squeezing the air out of which, the adhesion is improved. These holders avoid the danger of mottled-marks produced by the warmth of the fingers touching the under side of the glass, but must be used with care. They must be wetted to adhere. If set down in places soiled by spilled solutions, these may be transferred to the back of the

Fig. 98.



plate, and thence to the negative bath, to its destruction. And occasionally the adhesion will give way during the pouring off: the operator must be prepared for this, and if he feels the plate slipping, must support it by the ends of the fingers till he can get hold of the corner.

Fig. 99.



Another sort is useful for keeping the hands clean during development. (Fig. 99.)

A good manipulator will find both these instruments useful.

As the film dries, the surface, which looked before perfectly smooth, will frequently show minute specks, which, by capillary attraction, cause the collodion to collect round them so that they form slightly raised spots. These are one of the great nuisances of photography, and one which no carefulness of manipulation will get rid of. The writer has even tried forcing collodion through thick filtering paper by the pressure of a considerable column, but the collodion so filtered produced them just as much as that filtered through sponge. These specks, as far as he can find, depend upon—

1. Minute filaments carried through the filter (if sponge) or coming from the filter itself (if paper or cotton-wool).
2. Dust on the plate before pouring.
3. Dust falling during the collodionizing.
4. Dust on neck of collodion bottle.

Of course cause (1) is beyond helping, and is therefore the most serious of all. To obviate (2) brush the plate gently with a soft wide camel's hair brush, or rub gently and very moderately with blotting-paper moistened with alcohol, just before collodionizing. Not using too much friction, or it will very easily become electrical and attract every mote in the atmosphere, and retain it obstinately.

Cause (3) is best obviated by having a special closet in the dark room for collodionizing. This is so desirable on hygienic grounds alone, that it should never be omitted.

Often these specks may be *floated off* by pouring on a good quantity of collodion, so that the excess in flowing off the plate may carry the speck or mote with it.

Only experience can enable the photographer to decide as to whether a film showing some of these specks must be wiped off again. If intended for copying, it must, invariably, be rejected; and, generally, if for portraiture. In landscape work, one or two small specks are not likely to show in the negative.

This is on the supposition that the particles are filaments of wool, or cotton, or other inert substance. Sometimes there may be chemical dust, as of hyposulphite of sodium, in the atmosphere. In this case the speck, after sensitizing, will appear *darker than the rest* when viewed by transmitted light, and the plate is, of course, worthless.

Attention to the proper moment for dipping into the bath is necessary, because, if the plate be kept too long, it is insensitive, and tends to marbled stains; if plunged in too soon, it may split in the bath. But even if the film does not split, it may still not have been dry enough, and may exhibit an appearance which no one, without instruction, would ascribe to the right cause. Some portion of the film will assume a peculiar appearance, not easily described, but very observable. Perhaps a better idea can be given by saying that it has something the appearance of wax, the structure of a freshly-broken cake of camphor, or of fused nitrate of silver; neither exactly conveys the idea, but are perhaps as good comparisons as can be found. This appearance is rarely at, or carried to, the edges, which dry faster, but is generally to the interior of the plate, and mostly covers a few square inches of surface. It rather gives the idea of some decomposition to the collodion, than suggests its true origin.

On the whole, it is perhaps better to remove the plate from the bath as soon as the greasy marks disappear. At this stage the iodides and bromides are still in excess at the bottom of the film; this bottom is therefore insensitive, and consequently the sensitive portion of the film is separated by this insensitive portion from contact with the glass, and thus the danger of stains from imperfect clearing is greatly diminished.

It has seemed to the writer that short immersions in the bath tend to produce images that rest *on* the film and are whitish powdery. Longer immersion gives an image more in the film, and a rich, creamy-looking negative. In this respect the advantage seems on the side of a little longer immersion.

§ 5.—Developers and Development.

Gallic acid, the first developing agent used, was in time superseded by pyrogallic acid, obtained from gallic acid by sublimation. Proto-sulphate of iron was found to give a softer picture, and needs less exposure than pyrogallic acid, and has by degrees wholly taken its place in wet plate development.

Operators differ a good deal in their views as to the proper strength of the iron developer for ordinary exposures, using from ten grains of sulphate to the ounce up to forty or more. The following proportion will be found to give good results. It will be needful, however, to bear always in mind what has been said on maintaining a due relation between the collodion and the development (p. 132), and to suit the developer to the needs of the film. A collodion containing much bromide will need a stronger developer than one containing less, and it will also need a longer development, because the deposit is more crystalline, and not so close and dense; it lets more light through, and will give a weak print unless the development is carried farther than in the case of a collodion containing less bromide.

No. 1. Stronger Developer.

Sulphate of iron	3 ounces.
Acetic acid	3 to 4 ounces fluid.
Water	40 ounces fluid.

No. 2. Weaker Developer.

Sulphate of iron	2 ounces.
Acetic acid	3 to 4 fluidounces.
Water	40 ounces fluid.

Aids to Development.—In developing plates, and still more in redeveloping them with pyrogallic acid and silver, the hands are apt to be much stained, and various contrivances have been sug-

Fig. 100.

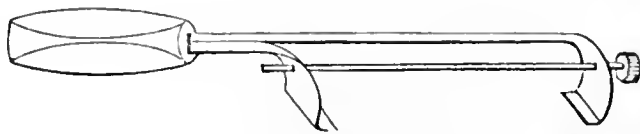

gested for avoiding this annoyance. The author, after trying such as had been proposed, with no satisfaction, devised one, of which the construction is explained in the adjoining figure.

Two brass rods, one considerably longer than the other, are fastened firmly into a wooden handle. At their ends the rods lead at right angles, and have pieces of silver soldered on to them. A rod passes through these, through one end it simply turns, but fits into the other with a screw thread. A mill head enables one to turn it conveniently. The plate is grasped so tightly as to give a perfect security, without ever being broken.

An ingenious contrivance for the same purpose was communicated to the author by Mr. Henderson, of Montreal. A brass

Fig. 101.



rod A C has a knob fixed at its end A, made by heating a piece of gutta percha and kneading it into shape while hot. A notch is made under it to receive the edge of the plate. A short piece of lead pipe, B, slides on the rod and is held by the thumb against the plate, which it holds in place. This plan is simpler than the first described, but does not give equal security.

If any repellant action show itself between the developer and the film, alcohol must be added to the developer, in such proportion as will check this tendency. An ounce of alcohol to eight, ten, or twelve of developer may be needed. This is a matter of no small importance, because the repellant tendency may at any moment lead to the formation of oily lines, and these, unless the plate is instantly washed off, almost inevitably produce streaks.

When sulphate of iron is used for developing *instantaneous pictures*, no restraining acid is employed, but simply a very strong solution of the iron, 80 or 100 grains to the ounce. Such a developer cannot, of course, be kept on more than a very short time, and the image once forced out, recourse must be had to redevelopment, or to after-intensification, to bring the image up to printing strength. Conversely, when a long exposure has been given, a good deal of restraining acid may with propriety be added.

It has been proposed at various times to place a very great number of various organic substances in the developer. Experience has shown that almost any organic substance may take the place of acetic acid as a restraining agent, and sometimes with advantage; for some of these substances have a remarkable

power of destroying the tendency to fog, so that the iron developer can be kept upon the plate like a pyrogallic developer. Thus redevelopment becomes wholly superseded, and the picture is always finished at a single operation. The substance that possesses this property in the largest degree is, as shown by the writer, gelatine, that has been treated with sulphuric acid, with formation of glycocine and tyrosine. The writer published several formulæ for this purpose, and the subject attracted at one time very great attention. Many experimenters went to work at it, and produced formulæ of their own. Since publishing, some years ago, the remarks on the subject that gave the initiative to what has since been written, the writer has remarked that the quantity of sulphuric acid necessary to modify the gelatine is absolutely so small in proportion that it exercises no hurtful agency upon the development, and *consequently it does not require to be removed by a subsequent neutralization*. This brings the preparation of the collo-developer to a singularly simple form, as follows: Take

Common glue	6 ounces.
Sulphuric acid	$\frac{3}{8}$ fluidounce.
Water	9 fluidounces.

Boil these together for a couple of hours in a flask, replacing the water as it evaporates. Then throw in an ounce of granulated zinc, and boil for an hour and a half. Add water as it evaporates, and, when done, dilute to twelve ounces.

This syrupy liquid has the most extraordinary restraining power. A single drop is sufficient for three ounces of 30-grain iron solution; one ounce, therefore, of the above gelatine solution is sufficient for 1500 ounces of developer.

Two essential remarks remain to be made in reference to this process. It might be alleged that the restraining power is due to the sulphuric acid by reason of its powerfully acid nature; but the writer has, by careful experiment, demonstrated the fact that sulphuric acid does not tend to restrain development, but tends to fog. It is therefore clearly not the sulphuric acid that acts.

Again, it may be alleged that by the long boiling with zinc, the whole of the sulphuric acid must have been removed by the excess of zinc present. But the presence of the gelatine checks the action of the acid on the zinc so much that it was ascertained by careful experiment that when the operation is performed as above described, at the end of a boiling of an hour and a half,

only *one-fourth* of the sulphuric acid was neutralized. This was ascertained by weighing the zinc before and after the operation, and determining the quantity of sulphuric acid corresponding to its loss of weight.

The action of the gelatine in this case in checking chemical action, prevents a very striking analogy to its action in the development.

The collo-developer, obtained by adding one drop of the gelatine solution, prepared as above, to three ounces of water and 90 grains of protosulphate of iron, develops rapidly and with less tendency to fog than the common iron developer. By somewhat increasing the quantity, the development goes on still more slowly, with still less tendency to fogging.

The Sugar Developer.—For the regular needs of the photographer no developer can be better than the sugar developer. The writer uses a formula of his own which he strongly recommends. It is as follows:—

In 32 ounces of hot water dissolve 7 ounces of protosulphate of iron. This is best done by letting a portion of the hot water stand over the crystals until it is pretty well saturated, pouring it off, and repeating it with a second and third portion. To this solution add 6 ounces of white sugar and $2\frac{1}{2}$ ounces of acetic acid No. 8. This need not be filtered. It is the sugar developer in a concentrated form, and keeps indefinitely. To prepare for use take—

Above solution	7 $\frac{1}{2}$ ounces.
Acetic acid No. 8	4 “
Water	18 “
Filter.	

It is perhaps an improvement to add a little sulphate of copper. An ounce of it may be added to the 10 ounces of sulphate of iron. With it, or without it, excellent results are got. The strength above given is suitable for winter, and may be diluted with from one-half to an equal quantity of water in summer.

Management of Development.—By close attention to the manipulations of the development something may be done towards controlling the nature of the image produced. *Softness* will be promoted by keeping the plates still whilst the image is coming out;—*contrast* will be increased by inclining the plate alternately at each end and keeping the developer continually in motion, because in this way the silver solution which impregnates the

film is much more washed out and mixed up with the developer. The strong parts of the image will always rapidly abstract the silver from the solution upon their portions of the plate; thus as the image comes out the shadows will continue to be moistened with a solution rich in nitrate of silver, after that which bathes the high lights has been more or less impoverished. This state of things is changed by keeping the developer in motion; more silver is then carried to the high lights, and contrast is heightened.

With very large plates it will be best to develop in a pan. The developer is poured in abundant quantity to the lower end of the tilted pan, one end of the negative is placed in the dry (upper) end of the pan. The pan is then brought to a horizontal position, and at the same time the negative is let gently down into it. In this way a wave of developer passes evenly over the whole surface. Unless flatness of effect is dreaded, it will be best to leave the negative at rest in the developer, and not to work backwards and forwards.

It follows from what has been said here and elsewhere that the operator must be governed in his development by a principle quite different from that which guides him in exposure. For whilst his exposure must be timed with a view to the worst illuminated part of the subject, the development will be guided by the high lights. These two principles are of such capital importance that they cannot be repeated too often, or mastered too thoroughly. They may be expressed in two rules, as follows:—

Expose the plate for the dark shadows, leaving the lights to be cared for in the development.

Develop for the high lights, keep the eye steadily fixed on the very highest light (the densest spot) of the plate, and stop whilst that is transparent enough to preserve its perfect moulding in the print to be made from it. The shadows are not to be watched in developing (except in *local redevelopment*, see below); they have been, or should have been, cared for in the exposure. Not that they are indifferent, far from it, but in point of fact, watching the high lights is doing the best possible for the shadows, the object of continuing the development as long as possible being to get out as much detail in the shadows as possible. Not they, however, but the high lights are to be watched, because we so ascertain the exact moment at which the development can be

pushed no farther, but must stop under pain of producing chalkiness and flat lights, which are simply ruinous.

Too much attention cannot be directed to this matter. It will be necessary for the photographer to learn by experience the appearance of the deposit when it has reached a point beyond which it must not go. This cannot be expressed or described, can only be learned by care and attention, and at the expense of spoiled plates. It is of course to be judged of by holding the plate up to the light; by degrees the operator will learn the point to which he can go safely. With practice the photographer will pick out at once the high light which he must watch; he will, in fact, have seen it in the subject before he uncovered his lens, and his attention will be directed to it as soon as he raises the plate to the light. On this portion his attention will be fixed throughout the development, and his anxiety will be always that it shall not reach the point at which it must stop before he gets the desired detail in the dark shadows. It has already been remarked that great care will always be needed in raising the plate to observe the stage reached, lest the developing solution break its even film into lines, producing streaks of unequal development, a trouble that besets every photographer in his earlier work.

Influences controlling the Character of the Negative.—Whatever influences in development tend to softness will, if exaggerated, tend to fogginess, and whatever helps brilliancy will, if exaggerated, produce harshness, because harshness and fogginess are the extreme terms of development.

Those, therefore, who seek for the softest effects will endeavor to keep just inside the line of fogging, and by the use of a strong developer will equalize the deposit of silver. Those who are anxious for brilliancy will use a weak developer, which will increase contrasts.

The anxiety for brilliancy which at one time existed has nearly disappeared. The magnificent effects of half-tone which have been attained by skilful photographers have produced universal desire for imitation. In fact, if different series of photographs be compared, it will be found that they are most pleasing in proportion to the amount of half-tone that they contain, and the recognition of this fact, both amongst photographers and the general public, is every day becoming more widespread.

If a portrait is harsh, crude, and unpleasing, with a want of

relief in its various parts; if the figure seems resting against the background, and if the eye has to examine the whole to estimate the relative positions of the parts, the capital fault (besides what others may exist) will be want of half-tone. A landscape that wants half-tone will be patchy and blocky; it will have a certain narrow and scant effect, an absence of boldness and breadth; the eye will not at a glance take in the relative position and bearing of its parts, but requires some moments of observation before it recognizes where everything belongs, and perceives that certain parts belong to the middle distance, so that the picture is not all foreground and distance, as it at first appeared to be. In such work, the leaves in the foreground will be either white, if well illuminated, or black, if not. It is such work that has led to the epithet of unartistic, so freely bestowed by artists upon the productions of photography.

How then is this invaluable half-tone to be attained? The answer is not so easy. First, it may be premised that it is the use of bromides in collodion that has made it possible, the use, not the exaggeration. Experience has shown that broad and expressive half-tones do not depend upon, and cannot be reached by any particular composition of collodion or of developer alone, but will depend upon a happy combination. And that in every case the conditions necessary can only be discovered by careful and intelligent observation. For any *good* specimen of pyroxyline there will be a certain proportion of iodide or bromide, and a certain strength of development that will produce good results, and these must be found by trials. (See p. 133.)

A serious difficulty is introduced into all photographic operations by the variable nature of the cotton. It seems almost impossible to repeat an operation for making pyroxyline twice, and get identical results.

It will be important to bear in mind that whenever a very considerable quantity of bromide has been used in the collodion the tendency of the deposit is to be more crystalline. A curious result follows, that in printing the plates show themselves to be less dense than they appear to the eye, and consequently they show less contrast.

It may consequently happen that such plates, whilst appearing to a good judge to have been developed exactly right, may yet in printing yield flat and unsatisfactory results. In changing

from one formula of salting to another it will be important to bear this in mind.

The whole tendency of modern photography is to full exposures and slow, careful developments. It follows, from what has been already said, that a full exposure absolutely necessitates a slow development, otherwise the negative is flat and tame, a fault now much commoner than it used to be when brilliancy was more sought after than half-tone. In fact, some seek so earnestly for masses of half-tone that they sometimes have no high lights at all in their prints: this is a fault which, though not as bad as the opposite error, is nevertheless a fault; no contrasts that can be produced on paper, as shown by Mr. Ruskin, can fully represent the ordinary contrasts of nature. We are, therefore, never justified in still farther contracting our means by substituting half-tone for high lights. Indeed, a certain quantity of high light is essential to give to half-tone its full value and due effect.

Washing the plates should not be hurried, but ample time be given to get rid of the hyposulphite, especially with valuable negatives. A simple arrangement for supporting the plate whilst washing is figured in the introduction at p. 36, and is specially recommended as facilitating a safe and perfect washing.

§ 6.—Local Redevelopment.

It will occasionally happen that after the deposit on a negative has reached a point such that, whilst the denser parts have received all that they can bear consistently with giving full detail in the high lights in the print to be hereafter taken, the thinner portions, or some of them, might advantageously have more strength, that is, these thinner portions, though exhibiting fine details to the eye, may be too thin to print properly. In order, therefore, to bring the negative into a condition to show the greatest possible transparency of shadow, that is, a clear rendering of details in the least illuminated portions, it may be very advantageous to resort to a *local redevelopment*.

This may be performed either before or after fixing. When done before fixing, there is more hope of adding to the details, when after, the operation can be performed more satisfactorily, because the operator sees far better what he is about. In the former case, although details not before visible may be rendered visible, yet it is doubtful if, within the limits of this operation,

detail so brought out can be got up to printing strength. The proper hope of this operation seems, therefore, to be the bringing of visible details, too weak to print, up to printing strength, and this is better done upon the fixed and washed negative. I shall, therefore, so describe it. It will be understood, however, that if preferred, exactly the same operation may be performed upon the unfixed negative, remembering that the same precaution as to light must be then used as in the regular development, otherwise fogging will ensue.

If the negative has been allowed to dry, it will be advisable first to go round the edges with India rubber dissolved in benzole. The film must then be well wetted, the plate is to be grasped by the left thumb and forefinger at one of its corners, and so held that those parts which are already fully dense shall be on the side of the plate farthest from the operator (in a landscape negative this will generally be the sky side); the plate is to be tilted a little, so that this far side will be a little the higher, and a solution of pyrogallic acid, silver, and citric acid, such as is usually employed for redeveloping, is to be dropped upon those parts where the additional deposit is needed. The plate being very wet, this dropping of solution will produce circles that slowly expand, and as they cease to expand wash down towards the edge near the operator, by reason of the tilting position given as above directed. As this takes place the operator holds the plate under the bath and washes off the solution. If the parts nearest to the operator will easily bear the additional deposit that they get as the solution passes over them, the operator proceeds more deliberately. If they are already pretty strong, he washes off almost as soon as the solution spreads to them. A few seconds suffice to wash away the solution, when the operator recommences, and this is done as often as necessary, even up to six or a dozen times.

By this mode of proceeding, spots and stains are avoided. If the solution were left to rest on any one part, a circular spot might result which would print lighter. The pyrogallic solution can be used pretty strong, but should be kept clear and colorless. The whole operation turns on not allowing the solution to be for a moment stationary anywhere, but washing it off as it ceases to spread, and recommencing. Of course, before washing, the greater part of the solution may be first drained off into the developing vessel.

§ 7.—**After-Intensification.**

The three stages by which the utmost possible density is acquired by a negative are—*development*, with iron, pyrogallic or gallic acid; *redevelopment*, by a second application of either of the foregoing reducing agents, not necessarily or even generally the same as at first employed, since iron is commonly followed by pyrogallic acid; and *after-intensification*, which last may be effected in a variety of different ways.

Redevelopment may be resorted to either before or after fixing, and in all cases is accompanied by an addition of silver solution. After-intensification is always applied *after* fixing, and silver is never used. The object of redevelopment is always to add more silver, without acting in any way upon the previous deposit. After-intensification adds no silver, but always acts chemically upon the original image, bringing it into a new combination more opaque to light.

When it is intended to apply an after-intensification, it is not usual to redevelop also, but to fix after the first development. It should be thoroughly understood by all students in photography that after-intensification is at best the remedy either of a mistake in the exposure, or else is rendered necessary either by a deficiency of illumination, or an exposure which for good reason has been greatly curtailed. Therefore, whilst a good knowledge of several modes of intensifying is necessary for the photographer, he should resort to them as little as possible. Where the exposure has proved much too short or too long, it is generally better, when practicable, to take another negative. It will cost but little, if any, more time; the experience of the first will enable the operator to time the second correctly, and the probabilities of a fine negative are decidedly greater. The following are the best methods of after-intensification:—

Iodine.—When only a little additional strength is wanted, iodine may be employed. If a few drops of tincture of iodine be dropped into a quantity of water, the latter acquires a pale sherry wine color, and if poured over a negative gradually blackens it, or rather brings it to an exceedingly deep violet black. The application must be stopped at this point by washing off the solution as its continued action brings the plate to a light yellow color. The solution may either be flowed over the plate,

replacing it with fresh as soon as it loses its color, or it may be applied as a bath.

Care must be taken that there are no undissolved particles of iodine present, as these may lodge on the film and produce yellow spots. For this reason many prefer to add a little iodide of potassium to the liquid, which enables it to keep more iodine in solution. This combination may be purchased of the druggist, under the name of "Lugol's solution," which may be diluted with thirty or more times its bulk of water and used.

Chlorine.—The blackening may be equally well effected by chlorine. Make a solution of bichromate of potash, one grain to the ounce, and add to each ounce two drops of hydrochloric acid. This solution is applied like the preceding, stopping as soon as a uniform dark color is obtained.

Corrosive Sublimate.—If a saturated solution of this substance be diluted with ten times its bulk of water, it may be applied precisely like the preceding, and blackens the plate very effectually.

The foregoing applications all give a moderate degree of additional density to the image, though the latter acts more powerfully in this respect than the others. They also act alike in this, that if their influence be continued too long, the images, after having become black, become lighter again; in the first case pass to a yellow shade, in the two latter, to white. In this condition, the film is in all cases much *less* dense than at first. In this stage, however, they are fit for additional treatment, which may confer upon them a much greater density yet, as follows:—

Sulphide of potassium will not act much upon the silver film, but if by the continued action of either of the three first methods, the film has been brought to the yellow or white stage, and then a dilute solution of sulphide of potassium be poured over it, the image acquires an intense blackness, so intense, in fact, that all middle tints may be expected to disappear. Nevertheless, there do exist cases in which this treatment may be applied with very useful results. Negatives of line-engravings, especially such as are of the full size of the original, are often very successfully obtained by developing only till an ambrotype is got, and then, without any redevelopment, intensifying in this way. But it is to be said that, in skilful hands, equally good and quicker printing negatives of line engravings are got by the ordinary develop-

ment and redevelopment, though they do not give prints which so easily tone to a perfect black as those yielded by the denser sort of negatives. Even, however, when these denser negatives are wanted, they may be still better obtained by the following:—

Cyanide of Potassium.—When a film has been treated with corrosive sublimate till the white stage is reached, there is often a little veiling produced, scarcely visible while the print has this light color, but visibly injurious after the blackening by sulphide has been effected. The writer has found it, therefore, useful to substitute *cyanide of potassium* for the alkaline sulphide. The cyanide solution must be very weak, one grain, or not exceeding two, to the ounce of water. It must be flowed over evenly, or applied as a bath, and must be washed off as soon as an even blackness is obtained. A continued action will cause the negative to whiten again.

This treatment gives great intensity, and, at the same time, keeps the transparent parts of the negative beautifully clear. For photographic operations in processes not intended to give half tones, it is exceedingly well suited, as well as for all cases where clean sharp contrast is a main object.

Schlippe's Salt—Scarlet Negatives.—This method of intensifying, which the writer introduced to photographic notice some years ago, has been largely used where great increase of intensity is needed, and with excellent results. The negative is first treated in either of the three first described methods: with iodine, chlorine, or corrosive sublimate, until the light stage is reached, and then, after washing, a dilute solution of Schlippe's salt (sulphantimonite of sodium) is poured over it. The negative instantly turns bright scarlet, presenting a remarkable and very beautiful appearance, and becoming very opaque to active rays.

The solution of Schlippe's salt should contain about ten grains to the ounce, and should be kept tightly corked. It, however, gradually deposits a precipitate, but if decanted from this it still acts well. The addition of a few drops of liquid ammonia prevents the precipitate and causes the solution to keep quite well. In this condition it does not give the bright-colored negatives before spoken of, but beautiful russet-brown ones, which are perhaps as non-actinic as those obtained without the ammonia. The color will also be found to vary a good deal with the extent to which the first application (of chlorine, iodine, or sublimate solution) has been allowed to act. The full scarlet color is got by

allowing the first action to reach the full light stage, and applying the Schlippe's salt without ammonia.

Solution of Schlippe's salt is apt to stain the fingers red. A little weak solution of caustic potash or soda instantly removes this.

It should always be borne fully in mind that operations with either sulphide of potassium or Schlippe's salt should be carried on away from the dark room, as the sulphuretted hydrogen, of which a little is diffused in the atmosphere, may tend to cause fogging. It is also injurious to the health to breathe a sulphuretted atmosphere, therefore a thorough draft should be provided to carry off such vapors.

Permanganate of potassium has been highly recommended for after-intensifying by Mr. Wharton Simpson. A dilute solution is poured over the plate till the requisite intensity is obtained.

Uranium intensifying is now abandoned, because the negatives rapidly become denser in printing till worthless; after-intensification with sublimate is, to some extent, liable to a similar objection.

In such cases it has been recommended to expose them to a gentle heat for a length of time, which treatment is said to lower the intensity. In copies of engravings without half tint (line engravings and wood-cuts, but not mezzotints, lithographs, or photographs) this increase of strength is of little or no disadvantage; in such cases, therefore, the mercury may be used without hesitation.

These processes may be divided into three classes, according to the amount of effect that they produce. For a quite moderate increase of density chlorizing or iodizing may be used. For a rather greater, but still moderate result, sublimate solution is suitable. When a very decided increase is needed, chlorizing, iodizing, or mercurializing, in each case till the light color is reached, may be resorted to, to be followed by Schlippe's salt or sulphide of potassium.

All the mercurial treatments weaken the film and render it liable to split in drying. If, therefore, a valuable negative is so treated, it is a prudent course to flood it with gum-water or solution of gelatine, the former about 30 to 35 grains to the ounce, the latter about 20 to 25. If intensifying is much practised it is well to have a solution of this sort on hand; it may be made to keep by adding either creasote or carbolic acid, one or two drops

to the ounce. The gum solution or gelatine is flowed over the plate for half a minute, worked in, and then poured off again, and the plate is reared up to dry. After thorough drying it is to be varnished. It has been affirmed that a plate so treated can be varnished cold without the varnish drying *dead*. On the whole, the gum-water answers better than the gelatine, and does not require to be warmed to liquefy it.

This mode of operating has, however, the disadvantage that the varnish cannot penetrate the film of gum (or gelatine) and does not reach the back of the plate. And as the gum and gelatine have no very powerful adhesion to the glass, the film is liable to scale off.

To Intensify Varnished Negatives.—The usual plan is to remove the varnish by soaking in alcohol or benzole, whichever has been used in the making of the varnish to be removed; then apply any of the intensifiers already described.

The complete removal of a lac spirit varnish by alcohol is no easy thing, portions of gum remain behind and refuse to dissolve. Some, therefore, intensify without removing the varnish. Mr. Alfred Hughes's method is as follows: Dissolve iodine in spirit varnish, one grain to the ounce, and varnish the plate with this varnish, without removing the first coat. Drain it well off, dry, and expose to the light, when a considerable increase of intensity takes place.

When the operation has been performed by dissolving the varnish, the use of an alcoholic solution of iodine, two or three grains to the ounce, is to be recommended, and acts more uniformly than any aqueous solution would. Care should be taken not to leave it on too long, and it must be borne in mind that the alcoholic solution cannot be instantaneously removed, like an aqueous one, as it takes a few seconds for the water to moisten the plate evenly.

According to Mr. Winter, the simple removing of the glossy surface of the varnish by a moderately strong alcohol, so as to give it a dead appearance, like ground glass, greatly increases the effective density of the negative. This of course applies only to spirit varnishes, and probably only to those made of difficultly soluble resin like lac.

§ 8.—Reducing Over-developed Negatives.

It will occasionally happen that a negative has been over-developed, and when examined after fixing and drying, gives evidence that it can be expected to yield only chalky high lights. This discovery may come too late to permit of retaking the subject, especially with landscape negatives taken away from home, and it should be more generally known than it is, that such negatives can be greatly improved by the following treatment, which the writer believes was first suggested by Mr. Hughes.

A wash of very dilute solution of *perchloride of iron* is applied to the film, which must, of course, be wetted beforehand. It is also better to apply an edging of India-rubber to make sure that the film shall not loosen, though this is not essential. The perchloride of iron can be got from any druggist under the name of "muriated tincture of iron." It is sold in solution, which must be largely diluted; from ten to twenty times its bulk of water will be needed. The first trial should always be made a rejected negative. The action is extremely rapid. The film apparently darkens, but on holding it up to the light, a welcome transparency will be found in those dense portions which previously threatened to print without detail.

If the negative wants very little reduction it will be prudent to use the solution still more dilute. In nine cases out of ten, if the perchloride does not give satisfactory results it will be from excess of strength in the iron solution.

This is the only application that has ever given the writer satisfactory results, or that he would think of employing. Its merit lies in that it does not eat away the image, but simply thins it, and especially that its action seems to be greatest upon the densest part. Thus the objectionable features of the negative are removed without material injury to the detail. Negatives that must otherwise be totally rejected may in this way become serviceable. This mode of operating is suitable for all negatives except those taken by the bromide dry processes.

Local Reduction.—Sometimes one particular object in a negative will develop to complete opacity before the rest has attained printing density. In such a case to apply a treatment to the whole negative would virtually destroy it, the thinner parts being supposed to be just thick enough. It is evident that if any re-

ducing treatment could be applied to the single object or few objects that are too thick, a great advantage could be gained.

Hitherto, the writer believes, this has never been attempted successfully, in consequence of the treatment inevitably extending to the adjoining portions of the image. It occurred to the writer lately to try the effect of *sizing the film* with gum and then applying the reducing agent. It was found that this treatment, as foreseen, resulted in making a change in the film similar to that which blotting paper undergoes by sizing, that is, that a solution no longer sunk into the film and spread around, but was completely localized in its action; and, therefore, that any single dense object could be reduced in a quite remarkable way.

The operation is as follows: Pour over the plate (of course before varnishing) a 50 grain solution of gum arabic, work it in, and let the plate dry. Then take some perchloride of iron (or muriated tincture of iron) and dilute it largely until it is of a pale straw color only. Apply this delicately on the part to be reduced, with a small elastic sable brush, keeping strictly inside the limits of the object. This presently diminishes very satisfactorily in density, and when a proper point is reached, the solution is washed off. It is to be observed that if the object proves not to have been sufficiently reduced, a fresh coat of gum must precede a new application of the reducing agent, supposing that the plate has been washed off. For washing^s quickly takes out the gum, and then the film returns to its blotting and spreading condition. This mode of treatment is really useful.

§ 9.—Negatives for Enlargement.

A negative intended to be enlarged from, should always be taken specially for that purpose. It is undoubtedly true that *some* negatives taken for ordinary printing are capable of being used for enlarging from; such are those that print easily in the shade. Usually, however, it is found better to take negatives expressly.

These must be thinner than usual, but it is not to be supposed that that thinness is to be secured by a brief exposure. On the contrary, *because* the development must be short, the exposure must be full, a little longer than usually given, so that the picture may flash up as soon as the developer is poured over it; and then, after a very few seconds, the plate is rapidly to be washed,

lest the deposit should become too thick. Van Monckhoven, who is excellent authority on this subject, remarks that the details in the shadows should be scarcely visible, and the denser parts so thin that one can read through them, and see the smallest objects without difficulty. Also, that negatives which are too strong are best reduced by plunging them into a bath of one grain of perchloride of iron to each three ounces of water; then, after washing, apply cyanide, which will reduce the strength. The operation to be repeated if necessary.

The deepest shadows should be represented by perfectly clear glass. Veiling that would be unimportant in an ordinary negative, will unfit one for enlarging.

Varnish is objectionable for many reasons. The best results are got with negatives washed and dried without even a solution of gelatine or other preservative. Some, however, do not hesitate to apply protectives, but, if possible, they are to be avoided.

§ 10.—Retouching the Negative.

Of late years the retouching of the negative has acquired a very great importance. It has been found that well retouched negatives will give prints so superior to those from unretouched negatives as to receive a very marked preference from the public.

It is not every one who can do this work, and it is, moreover, found to be very exhausting to the eyes, especially when done at night, by artificial light. It should, therefore, be always done by daylight, on a retouching desk, or, for want of this, a large piece of ground glass may be rested in a somewhat inclined position, and a looking-glass placed under it, and near to a window. The negative being laid upon the ground glass, all its details will appear distinctly. The eyes should be protected by drawing down a curtain so as to admit light upon the looking-glass only. In some establishments this is more completely effected by arranging a partition in front of and near a window. In the partition an opening is cut sufficient to let the light upon the mirror only.

Several modes of retouching are practised. A soft Faber's pencil, B B or B B B, may be used, or water-color be applied with a sable pencil. As the varnish does not take these applications easily, it requires a preparation. Some prefer to take off the glazed surface by rubbing gently with turpentine. Others

take finely powdered cuttle bone and rub it gently with the tip of the finger until the glassy surface becomes mat and takes the application.

Excellent results are got both from the pencil retouching and the water color. When the pencil is used, it is found advantageous to go over it with a stump, such as is sold by the dealers in artists' materials; this softens and harmonizes the effect, and blends it with the neighboring tints.

Water color retouching has the advantage that it is easier altered, and that, if mistakes have been made, they are easier to rectify. Experience shows that the best results are got by using colors that are rather transparent to the actinic rays—blue or neutral tint. This is to be carefully laid on until the desired effects are attained.

Too great a smoothness is not to be sought for, as the character of the face is removed. But as defects of complexion, freckles, pimples, or irregularities of skin, are apt to be exaggerated in photographic work, the removal of these by retouching improves the picture amazingly. So that those professional portraitists, who have judiciously retouched their negatives, have found themselves suddenly overrun with work.

Retouching is especially useful in removing the blockiness and want of moulding that results from one part of the face printing too light or too dark in proportion to the rest. It is evident, however, that if a negative is already too dense, retouching is scarcely applicable, because it can only increase and not diminish the opacity of the image.

The effect of a retouched negative is almost always more pleasing and more flattering than that of one unretouched. Because wrinkles, deep folds at the angles of the mouth, and lines under the eyes, are all apt, in photography, to be much more conspicuous than in the face itself; by retouching they are subdued to any extent desired, and very pleasing and even flattering prints are obtained from negatives otherwise unsatisfactory. Practice and some artistic skill are necessary, however; the rounded shape of the cheeks must be preserved, and the face be not too much flattened. A little careful and systematic practice will give an insight that no directions can. It is evident that the negative must not be too dense to begin with.

Another method of retouching the negative is to work upon the back. As the colors do not take well upon glass, it is usual

to apply a thin varnish, and then to take its surface off in the same way as directed for preparing the film side. The interposition of the glass causes the retouching to print less sharply and more softly than when it is put upon the face; there is also no danger of injuring the image. The same modes of operating, the black lead pencil or the water color, may be used.

Still another method is to attach thin letter paper to the back by pasting or gumming at the edges, and then applying color, &c., upon the paper; this method has been long in use for sketching clouds into the transparent skies of landscape negatives.

For stopping out small holes, Indian ink is generally used. A color which contrasts with the negative is always desirable, as it is easier to see what is done; therefore if a negative has been blackened by any after-intensification, it is more advisable to touch out holes with a red color. Vermilion is very effective, and seems to stand the sun pretty well. The indefinite permanence of Indian ink against all action of light is an argument in its favor that is not to be overlooked.

To landscape work little can be added by retouching, except in the way of stopping out small holes or minute defects. If it be attempted to materially alter the lights and shades of a landscape negative, a peculiar and artificial character results, which may perhaps be an improvement in the particular case, but such work can rarely be considered first-rate. In this is an essential difference between landscape photography and portraiture, that the best portraits are almost always those that have been skilfully retouched, whereas the contrary is the case in landscape work.

The *pasting of paper* behind parts that are intended to be lighter is a well-known artifice; but it only answers well when the borders of the part to be influenced are pretty well defined. Some curious effects of light exhibited in this city have been so produced. A female face, for example, is raised upwards, and a beam of sunlight falls upon it from a window, lighting it up in a striking way. The beam and the effect upon the face are produced by pasting thin paper on the back of the negative, and printing in the shade. It is scarcely necessary to say that the paper must be selected with a very even grain and an absence of the lightish dots so commonly found in thin papers.

Hard and blocky negatives can often be made to yield materially softer prints by printing under ground glass, as will be more fully explained in the chapter on printing.

§ 11.—Other Artifices Connected with the Negative.

Other ingenious operations have been performed on negatives, either to remove blemishes or to produce particular effects. Thus Mr. Notman, of Montreal, has produced prints in which the effect of *falling snow* is very well represented. A white pigment mixed up with water moderately thick, is put on a brush and scattered over the negative with a quick jerk, probably an "atomizer" would be preferable. Snow-banks in these pictures were made in the studio of common table-salt, which also, when scattered over clothes and drapery, gives a very good imitation of the effects of snow caught in the folds. Clear ice was represented by plate glass resting on sheet zinc: figures in skating attitudes were posed on this. The positions of rapid skating motion were obtained by supporting the model in the desired position with Sarony's apparatus, the stem of which was concealed behind the leg of the skater which touched the ice.

One peculiarity of photography lies in the opening it affords for original devices of all sorts by the ingenious. This seems the proper place to mention a few of them.

Ghosts.—This name has been given to prints representing a shadowy figure through which all the objects behind it are distinctly seen. Such pictures are obtained by causing the model, after remaining standing or in a chair for a short time, to move suddenly away, whilst the exposure is completed without him. In such a case it is evident that the objects at first concealed by him will afterwards impress themselves on the film, and be visible through his figure.

Doubles.—A model may appear twice in the same print by having a couple of folding doors arranged inside the camera, a little in front of the film. One of these being closed, the sitter is taken on the other half. This then is shut, the other door opened (the lens being covered during the change), at the same time the sitter is transferred to the other side, and taken again in some different attitude, as, for instance, offering a glass of wine to his double across a small table. By accurate adjustment a man is made to shake hands with himself. The position of the doors causes them to be very much out of focus, so that they do not show in the image.

Moonlight Effects.—Although a negative of the moon itself can be easily obtained in the camera, and although it is affirmed that

a dry plate exposed under a negative for a long time to moonlight gives signs of an image, yet nevertheless the photographing of objects illuminated by moonlight is practically impossible. Prints, however, from under-exposed and over-developed negatives often have a resemblance to moonlight views. For in effect if we observe a view by moonlight we shall notice that there is almost a complete absence of diffuse light. Objects in shadow are not lighted at all. A tree seen by moonlight exhibits a bright mass of light where the rays fall, with a moderate detail; in the shaded foliage there is absolutely no detail at all—it is a black mass. Now these effects are those that belong to badly-made negatives, with all their worst faults of exposure and development. But these same faults, when intentionally introduced and artistically managed, are capable of producing very pleasing effects. Ferrier, in Paris, has been particularly happy in some of these. The moon itself is produced by a piece of paper pasted on the negative.

Mr. Baker, of Buffalo, gives the following directions: A day of floating clouds is selected, and when the sun is low and hanging over the water surface of a river or lake, or of the sea, the camera is pointed towards it. At the moment when a cloud passes over the sun the exposure is made. The time given is of course short, and the result is a "moonlight effect." The clouds near the sun throw brightly-illuminated reflections upon the water.

Artificial Clouds.—In cases where the sky of a landscape has become much thinned by solarization, it may admit of painting-in clouds. This is done by the application of transparent water colors on the back, in imitation of natural clouds. No small skill with the brush is necessary to produce good effects. The description of clouds known to meteorologists as the *cumulus*, the *cumulo-stratus*, are those most successfully imitated. The photographer should bear in mind that the direction of light must correspond with that of the picture, and also that unless the sun is very low, heavy clouds are always darkest underneath.

§ 12.—Combination Prints.

This term is applied to the obtaining in one print of effects that cannot be secured in any one negative, and which are, therefore, taken on two separate plates and combined together in

printing. Most commonly this is applied to the introduction of figures into landscapes, in some cases the figure being the principal subject and the landscape subordinate; in others it is the reverse. The means employed are the same in both cases. On the plate upon which the figures have been taken, everything else is completely stopped out by overlaying it with opaque color, so that if the negative were printed in this condition, it would print nothing but the figures upon a perfectly white ground. Next, upon the landscape negative, the portion of the plate corresponding to the figures is stopped out in the same way. Of course if this negative is printed on silvered paper it leaves a white space corresponding to the figures; and upon this space the figures can be next printed from the figure negative.

The difficulty of course lies in bringing the paper into the exact position for the second printing, that the space left for the figures shall fall exactly under the proper portion of the negative. To do this requires a careful and experienced printer, and the trouble must be repeated for every print. This difficulty has very much limited the practice of composition printing, but is in a great measure obviated by the ingenious registering frames of Mr. Edwards and of Col. Stuart Wortley. A printing frame is constructed in which four small square grooves A B C D, Fig.

Fig. 102.

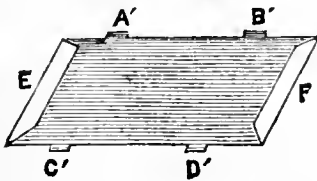
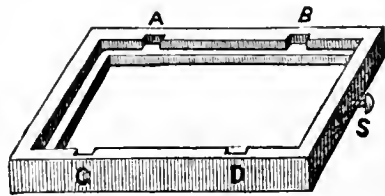

Fig. 103.



103, are cut, extending down to the rebate on which the negative rests. A piece of thin wood is cut with four square projections A' B' C' D', Fig. 102, exactly corresponding to these four grooves, so that when this piece of wood is let down, the grooves act as guides and bring it always exactly into the same position. A wooden screw S serves to press on the negative and keep it perfectly steady and immovable. A piece of silvered paper has its ends bent over the piece of wood, as shown at E and F, and secured with a little gum. When it is intended to print, this board is put into the frame, paper side down, the projections slide down the grooves, bringing the paper always into its proper position. Pads and packing are put behind the board, and the back (which is not shown in the cut) is then fastened down.

Two frames of this sort are provided, in one of which the figure negative is placed, in the other the landscape. Having stopped out all but the figures themselves in the figure negative, a print is taken on the silvered paper that has been fastened to the board. This is transferred to the other frame, and the portion of the landscape negative corresponding to the figures is accurately marked and stopped out. This being done, it is evident that the printing proceeds without difficulty; instead of a very skilful hand being needed any ordinary printer can take off hundreds of copies with perfect accuracy. Each piece of paper is secured over the edges of the board and is printed, first in one frame and then in the other.

§ 13.—Printing in Cloud Skies.

The preceding method may be applied to printing in clouds, but as the same accuracy is not required, simpler means are sufficient. If the negatives have not an opaque sky, that portion is covered with opaque paint to render it so.

A print is taken and the sky cut carefully out from it and rejected, following as nearly as possible, but in flowing lines, the outline of the landscape as projected against the sky. This is done immediately after the print is taken from the frame. Next, expose to light, when the whole becomes perfectly black, and fix without toning.

A good sky negative with suitable character of clouds and direction of light is taken, and the black mask above prepared is neatly attached to the back of the sky negative, *the white side next* the glass. The sky negative is now ready for use.

Prints from the landscape negative, when removed from the printing frame, are placed under the sky negative, and printed again. The black mask protects all but the sky, which receives the cloud image from the second negative.

Printing of this kind requires, of course, to be done in the shade, otherwise the line of the mask cannot be so well concealed. This object is best attained by having a border of sky in the mask—that is, not cutting too close to the landscape. With ingenuity and care beautiful results are got in this way, and effects can be obtained that, when exhibited, puzzle even the photographer who is not acquainted with the mode in which they are accomplished.

For example, if a dead tree, or a tree without foliage, as in winter, or with but small foliage, showing the sky through as in early spring, stand well out and detached from the sky, clouds may be printed in behind it, showing through the branches. This is done by cutting out all that part of the tree that is thus open, along with the sky, so that all such part of the tree is not masked. The clouds are then printed in, and as such a tree presents little or no aspect of light and shade in its slender branches standing against a bright sky, the second printing does not affect it otherwise than to make parts a little blacker, a result that is not injuriously noticeable in the finished print.

A splendid effect is produced by printing *reflected clouds in water*. It requires three printings. A scene is chosen with a wide expanse of water and sky. The sky and water are both masked; the sky first printed in, and then the cloud negative turned over so that what was before the top, becomes the bottom, and the film or varnished side is away from the paper. The reflection of the cloud on the water is thus obtained by printing *through the glass*, which gives it just the amount of indistinctness wanted, whilst every cloud and shade of cloud in the sky is faithfully rendered in the water. The deception is so complete that it is difficult to persuade one's self at first that the whole was not taken at once, and the reflected clouds obtained at the same time with the real ones.

The same general methods have been used for obtaining effects much more odd than pleasing—as, for example, a card portrait is printed of a man standing before his own tombstone, with his head severed from his body, and grasped by the hair with one of his hands. The trees and objects behind the portion where his head would properly be, are all perfectly well made out, so that the deception is complete. This is done by masking and repeated printing. There are several ways in which it may be thus managed, but the subject has not sufficient importance for the space the details would occupy.

§ 14.—Negatives by Magnesium Light.

Some successful applications have been made of the magnesium light to photography. Thin strands, coils, or wires of that metal, when set fire to, burn with a splendid blue light, very rich in actinic power; negatives may be very well taken by it. Interiors

and parlor groups have been photographed at night by it, and pictures taken of caves, catacombs, and other places inaccessible to daylight.

The chief difficulty in obtaining good interiors results from the *directness* of the light. If one light be used, of course the shadows exhibit a total want of illumination. At least two are necessary, and this immediately introduces the danger of *double shadows*, an evil which is not known in the carefully adjusted light of the ordinary glass room, and which will require special attention on the part of the photographer. Objects must be so placed that only one set of shadows shall be visible, and the lights themselves must also be regulated with this view.

Of the two lamps used, one must give the predominant light, and the other be used to light up the shadows. The predominant light should be, of course, like the light of the glass room, a side-upper-front light. The other must be lower in height, and be placed at the other side. The predominance of the first is secured by burning twice as much magnesium in it, say three to five tapers.

The writer has elsewhere pointed out that as the light of the magnesium diminishes rapidly as the distance from the lamp increases, the *background* must be much lighter, or it will show too dark in the picture.

Very ingenious lamps have been constructed for burning magnesium, especially one in which a draught of air, kept up by a chimney, is made to enter in front, and thus to keep the heavy white smoke of magnesia, which is generated by the combustion, from obscuring the light. It is affirmed by competent observers, that the effective light produced by a given quantity of magnesium is nearly doubled by this simple contrivance.

Mr. Skaife substitutes a pyrotechnic mixture burning with a very luminous flame, a mixture of magnesium filings, chlorate of potash, and sulphur, which he suddenly inflames. The camera has been previously focussed by gaslight, and is left open, as the gaslight makes no impression. Then the mixture being suddenly inflamed gives an intense light for a moment, during which the image is obtained.

§ 15.—Storing of Negatives.

There are three ways of storing away negatives, that are in common use—plate boxes, shelves expressly made for plates, or

the plates are wrapped up in clean paper in bundles of ten or twelve each.

Plate boxes are made with either single or double grooves. In the latter, two plates are slid together into each groove, back to back. Much trouble arises from the grooves in plate boxes not being made deep enough. The plates vary a good deal in size, although nominally intended to be equal, and the boxes sometimes shrink very much; so that in some, after having been made some time, the small plates will get loose instead of being confined, and, in other boxes, the plates a fraction over size will get fast. It has happened to the writer to be obliged to force out the side of a box to get out a negative. All these troubles should be avoided by making the grooves deeper. The edges of the groove should be rounded, not square.

Plate boxes should never be used for putting wet negatives into, both because the boxes should never be wetted, and because, if the washing has been imperfect, hyposulphite may be introduced. Nor should negatives just varnished be placed in them, as the edges of varnished negatives remain sticky after the face is dry. Nor should "dry" plates be dried in them; in a word, they are for storage only.

Shelves for negatives should be built very strong, and are better so placed that the window shall not be opposite to, but at one end of the room, on the side of which are the shelves, so that as they are drawn out they can be looked through to obtain the one sought.

Negatives wrapped up in paper have been found to keep better than in any other way. Cases are described in which some of a lot of negatives have been stored in boxes, some wrapped in paper and laid flat, where those in boxes have cracked, and those in paper have stood perfectly. The reason appears to be, that plates sliding separately into grooves are exposed to changes in the atmosphere to a much greater extent than those securely wrapped up and pressed closely upon each other.

It is evident that considerable care should be exercised in the selection of paper to be interposed. Printed or soiled paper should be rigorously excluded. Blotting paper is too porous and hygroscopic. An ordinary quality of sized paper, not too hard and stiff, is the most suitable.

The outside paper should be good, strong wrapping paper.

Paper saturated with India-rubber varnish would doubtless be better than any other. For amateurs who have but small numbers comparatively of negatives, the plate box is so much the more convenient form that it will probably be always that used.

CHAPTER V.

AMBROTYPES AND FERROTYPES.

ALTHOUGH ambrotypes almost belong to the past, a few brief remarks will be made on the subject here for the benefit of those who may desire to make them. A really fine ambrotype is a very beautiful thing, but for the most part, they want contrast and breadth of effect.

An ambrotype is nothing but a thin negative. When a negative is held up to the light, those portions on which the light has acted in the camera are more or less opaque, and the lights and shades in the original are reversed in the negatives.

But the negative is formed of grayish-white silver powder, so that if it be viewed by reflected light, and held against a black background, those parts which looked dark by transmitted light, appear light by reflected, and the transparent parts, which permitted the light to pass through when viewed by transmitted light, look dark in the ambrotype, because their transparency permits the black background to be seen through.

Formerly, a different bath was thought necessary in the two sorts of work. Now the same is generally used, although many prefer to acidulate it with one or two drops more of nitric acid.

A formula for collodion (if a special collodion be desired, which is not absolutely necessary) will be found in the Introduction, p. 43.

The developer is the same as for negatives, a little more acidified. Or, when *brilliant whites* are wanted, take—

Sulphate of iron	250 grains.
Acetic acid, No. 8	half an ounce.
Best granulated nitre	30 grains.
Water	20 ounces.

As the bath becomes older, add a little alcohol to cause the developer to run smoothly. If there is any disposition to fog,

increase the dose of acetic acid. Stop the development as soon as the image comes out enough to be seen in light reflected from the surface of the plate.

Where dead whites are wanted, omit the nitre.

Melainotypes and ferrotypes are ambrotypes taken on plates of thin varnished iron instead of glass. The operation is in all respects similar. They may be said to constitute the most ordinary and least artistic of photographic products.

Opinions vary very much as to the best means of getting good results. The points are these, that a very clear, clean picture must be got. This of course is most easily effected by the aid of acid. The acid may be applied in various ways. For example, the bath may be made more acid than usual with nitric or acetic acid, and used with the ordinary collodion and development. Or an ordinary bath may be used with a very ripe collodion, or one to which tincture of iodine has been added; or a very acid development may be resorted to. It naturally follows that whilst very clear pictures are got in this way, there is an absence of detail often observable. The right plan is just to carry the acidification far enough to get clean glass in the darkest shadows and no farther. Of course the slightest veiling is fatal to the ambrotype.

Collodion made with alkaline iodides and bromides ripens quickly; some therefore omit entirely the cadmium salts from collodion intended for ambrotypes. Others employ cadmium and ammonium and add iodine, and others, as mentioned in the Introduction, consider potassium essential.

Alabastrine Positives.—The body of both the negative and ambrotype is composed of nearly pure silver, which has a grayish tint, and is deficient in brilliancy. This defect injures the light and shade of the picture, and recourse is sometimes had to mercury in the form of corrosive sublimate to whiten them.

The following formula may be used:—

Corrosive sublimate	40 grains.
Protosulphate of iron	20 grains.
Common salt	15 grains.
Water	2 ounces.

The first effect is to make the picture grayer, but the whitening soon sets in.

CHAPTER VI.

PORTRAITURE.

§ 1.—General Arrangement.

HAVING placed the sitter in an easy and natural attitude, and with due attention to the management of light, as described in the next section, it will not be sufficient to simply set up the camera before him and take a picture. Care as to the point from which the picture is taken is of the very highest importance.

If, for example, the camera is set as high as the head of a standing figure, and is directed at him horizontally, the head will occupy the centre of the plate, the body one-half of the plate only. If we move the camera down so as to be opposite his middle, we shall get the whole figure it is true, but we get the figure as seen by an eye placed no higher than the camera. The shape of the nose is altered and injured, the neck is shortened, and the whole character of the face altered.

From these difficulties we are relieved by the contrivances already explained in a previous chapter, the swing-back and the sliding front. We raise the camera at least as high as the shoulders. The first effect of this is to throw the head nearly into the centre of the plate and to cut off the feet. This may be remedied—

1st. By inclining the camera downwards. This tends to distort the vertical lines, and here the swing-back comes into play and straightens them, or,

2d. By lowering the sliding front. As the front is lowered, the image moves down the plate, and takes its proper position.

This last arrangement has this notable advantage over the first, that the best definition, which in the portrait lens correctly focussed is that of the central pencils, is got for the head, precisely as if the bust only were taken. In the first arrangement the middle of the body is formed by the central pencils and receives the best definition. On the other hand, the lowering of the sliding front has this disadvantage, that the feet and lower part of the picture are then formed by pencils more excentric

than enter into any part of the picture in the other case. Each method has its advantages and evils, and in some cases the one, in some the other, will be proper.

The swing-back is so valuable an adjunct to portraiture that no one who has learned how to use it will ever willingly work without it. It is especially useful in sitting figures; without it, for example, the feet will always be exaggerated in size, and clumsy looking. It gives, in fact, a new power to the operator; the plan of revolving the lens does not, as so often affirmed, answer equally well.

A *repeating back* enables the operator to make the image of a lens fall in succession on different parts of the sensitive film, thus with two lenses and a repeating back, four or more card portraits are taken on one plate.

Distance of Position.—As a large lens will produce a small head by increasing its distance from the sitter, and conversely, a small lens will give a large one by diminishing it, the question naturally arises as to what are the best conditions under which to obtain satisfactory results.

The impression of relief and rotundity is greatest with very short focus lenses, and gradually diminishes as the size of the lens increases, until with lenses of 30 or 40 inches focal length, relief almost disappears (also the size of the stop has much to do with it, a large stop giving much more relief with the same lens).

But, on the other hand, this excessive effect of rotundity and relief is anything but pleasant in itself, and, still worse, it is connected with an effect of "violent" perspective which draws the middle of the face outwards, and in a full-face portrait, swells up the nose and lips most objectionably. The effect is detestable in those faces in which the size of the lips and nose is as large as the rest of the face will bear, the enlargement of them introduces a disproportion most annoying and vexatious to the sitter and friends, whereas in another face with thin lips and small nose, no bad result has attracted attention, simply because other circumstances rendered it less obvious.

It will be well, therefore, never to place the camera nearer than twelve feet from the sitter as a minimum, and rather to exceed this by using a larger lens to make up for increased distance. In fact, there is but little danger of getting too far from the sitter in any ordinary glass room; the danger is the other way.

Arrangement of Accessories.—The curvature of the field of lenses

renders it desirable that objects around the central figure should also be arranged into a counteracting curve, and be brought *nearer* to the camera in proportion as they are farther from the centre of the field of view. This enables them to be brought into focus simultaneously with main figure.

Groups are naturally governed by the same rules. Of course a stiffly circular arrangement is to be avoided, but it will be always advisable to arrange that in a group the most distant head shall be central, and those that are farthest from the centre shall be nearest to the lens. A tasteful arrangement of intermediate heads and figures will bring the whole into harmonious combination.

With groups the swing-back will be always very valuable, especially in avoiding sameness. For with a swing on a vertical pivot, the figures on one side of the central object may be set as far back as the central figure, and yet be brought into good focus, provided that those on the other side are brought considerably nearer. The advantages of the swing-back will thus continually make themselves apparent, and multiply as the photographer increases in familiarity with its applications.

Relative Size of the Figure.—It is highly important to proportion the size of the figure to the size of the whole print, and it may be said that the size of the figure is almost always made too small. For one error in the opposite direction, ten are made in this, and the result is always to render the figure insignificant and unsatisfactory. This remark applies to all sorts of photographs, from vignetted busts to full lengths. And the smaller the figure the more conspicuous any accessories that may be present, until, in some portraits, they fairly eclipse the figure itself, so that the idea is conveyed that the sitter is taking care of the large but suspiciously unreal-looking vases, tables, and carved furniture, which, rather than the person, seem to be the actual subjects of the picture.

It is surprising that so little criticism has been directed to this almost universal fault. An examination of portraits by great masters will show a very different system. The figure takes up a very large portion of the whole surface, the accessories are absolutely subordinate, and not noticed unless attention is expressly directed to them.

No error produces worse results than this of making the figure too small. The sitter feels the unsatisfactory and insignificant

effect of the portrait offered to him, without understanding why it is so, and though he may be unable to say where the fault lies, its existence is perfectly plain to him. The photographer is, therefore, recommended to avoid this mistake most carefully.

§ 2.—**Management of Light.**¹

The play of light upon the sitter must be regulated partly upon certain general principles of illumination, and partly according to the needs of the particular case.

The general principles are—

That there shall be no *cross light*; never shadows visibly cast in more than one direction.

That the light on the side away from the glazing shall be maintained as subsidiary.

That there shall be no false light, especially no false reflection from the eyes.

That there shall be no excess of illumination in some one or more parts of the picture, otherwise the eye will be *led away* from the face instead of *led to it*, as takes place in a judicious distribution of light and shade.

That the shadows, wherever they may be, shall invariably receive a sufficient illumination that their details may impress themselves with strength enough to show agreeably in the print. There must be no dark patches destitute of detail.

That the highest lights shall not be so illuminated but what they shall be full of detail. A bald head, for example, must not run into a light background, as is occasionally seen. White hair must preserve all its details. The play of light and shade over white garments must be thoroughly well preserved, and all white patchiness rigorously excluded.

Conjointly with the above, two different systems of illumination may be used. There is that almost universally adopted, in which the effect of the picture is made as nearly as possible to imitate what we commonly see around us. The part of the room, for example, in which the model sits, is made, in its play of light and shade, to resemble ordinary rooms.

There is another and very effective system occasionally used

¹ See also chapter on the "Glass Room," and that on "Light and Shadow."

in which some of the effects generally produced by distinguished portrait painters in their work, are imitated. The object of this system is to allow no light, except that which stands in some definite relation to the face. It was the dictum of a celebrated painter that a portrait ought to be two-thirds dark.

To obtain this effect in photographic portraits, a dark background and dark hangings are used. Dark clothing is worn, especially dark velvets, whose play of light is always exceedingly effective in photography. Whatever of light is permitted in the clothing must "lead up to the face," that is, so far as it is permitted to catch the eye, the eye must pass directly from it to the face. All this, of course, is more easily effected in women's vestments than men's; still the application is not confined to the former. The borders of the picture are all kept dark, and, in fact, the shadows are accumulated in order that the light may tell as effectively as possible. When well managed, this method produces very striking and beautiful results, but it requires considerable artistic knowledge and feeling on the part of the photographer. From the large use which Salomon, of Paris, has made of this style, it is often called after him. The "*Berlin Portraits*" are made by taking a piece of glass, coarsely ground upon one side, and making the negative upon the other. In this way a certain softness is got, somewhat resembling, but inferior to, that which is obtained by retouching. "*Crayon Portraits*" are produced by printing a thin positive on glass, and laying this, film side down, upon a lithographed sheet, shaded in imitation of crayon work. When well done, the effect is good. The glass positives for this purpose are often enlargements from card negatives—the enlargements are made in the camera. Others modify the effects and soften their paper points by interposing a sheet of glass, of gelatin, of mica, or of tissue paper between the negative and the paper; in this way are made the so-called "*Mezzotint Prints*." This method, brought prominently forward by Meinert, gives often very pleasing pictures.

So-called *Rembrandt Effects* represent the head against a dead black surface, with a peculiar and bright illumination round the profile, brightest on the side away from the spectator. The effect is produced as follows: The lighting is as usual; the sitter is placed in the usual position. The camera is moved partly round so that it somewhat faces the light, and thus the portrait shows principally the side of the face that is farthest from the side light,

what shows of the other side of the face, viz., the eyebrow and cheek, is more brightly lighted than the near side, the former being nearest to the light. The background must send no light back, and is best made of black velvet, which should be rendered clear glass. As the camera is turned partly towards the light will need to be carefully shaded, otherwise the brilliancy of effect, and entire blackness of the background may be impaired. Finally, it is to be observed that the photographer must not transfer any system of lighting from a given lens to another of any different focal length. If accustomed to work with a lens of a certain focal length, he finds occasion to change, it will be necessary to study a proper arrangement for the new lens. A lens of long focus will bear a bolder lighting than one of short focus, and for want of it may seem tame and flat.

§ 3.—Exposure.

A correct knowledge of the time of pose comes only with long practice and through many failures. Not only does the light of the glass room vary continually in strength, but different complexions and different clothing will alter the needful time. Moreover, the photographer's task may be greatly increased in difficulty if a style of clothing, unsuited to the character of the sitter, chance to be worn by him or her. It would, in fact, be very advantageous if the photographer could always direct in advance, after personal observation, what description of clothes should be worn during the pose, for it by no means follows that clothes most becoming to the wearer under ordinary circumstances will be most appropriate before the lens. The element of *color*, which enters so largely into consideration, as to suitableness and effect, here disappears, and the only question is as to the rendition of light and shade on the film. A photographically suitable clothing is, therefore, not at all one in which the colors harmonize with the character of the wearer, but one in which the photographic effect of the color harmonizes with the photographic character of the face and hair. To get a clear insight into this matter it will be necessary to begin by considering the relation between the skin, eyes, and hair.

A clear white skin will, of course, impress its image rapidly on the film. If the hair be fair, all will go on well and harmoniously. But if a white skin be combined with dark hair, the

exposure will have to be more accurately timed, it must be continued until the details of the hair are fully out, and yet must be stopped before the face is overdone. Conversely, where light or white hair accompanies a red or dark complexion there is danger of the hair being overdone and the details lost in it before the face is duly taken. These are faults that are constantly seen in card portraits, and constitute difficulties to be understood and conquered.

Dress.—The clothes worn may evidently add a further complication to such of these difficulties as exist, or may produce them where they did not. Let us suppose that a lady with dark hair and complexion presents herself to be photographed, attired in white, or light blue or purple. It will follow that by the time that justice has been done to the face, the fine gradations of shade in the dress may be lost, or, if preserved, it can only be by skill and care.

The difficulties occasioned by contrast are, however, now far less unmanageable than they formerly were when iodide of silver alone was used, and we see less tendency than formerly to black spaces destitute of detail, and white ones perfectly flat: these blemishes are now comparatively exceptional, and such work is always destroyed by the intelligent photographer who prizes his reputation.

Some photographers keep two kinds of collodion on hand. One sort for regular use, the other containing more bromide, to be employed where too much contrast is apprehended, especially where masses of white drapery are to be taken, in which case the proportion of bromide may rise to one-half. For regular use such collodions are liable to the objection that they yield thinner pictures and require more redevelopment.

Nothing is commoner than for persons to present themselves so attired as greatly to increase the photographer's difficulties. Harsh contrasts, the effects of which are sufficiently bad on the persons, become almost intolerable in a picture. Add to which the various actinic powers of the different tints often tend yet farther to exaggerate those contrasts which were before sufficiently annoying to the eye. A portrait in which the dress is cut up into checkers of light and dark, or divided into parallel stripes with striking contrasts, must always be unsatisfactory in its character.

Attempts not wanting in ingenuity have been made to exhibit

in photographic specimens the actinic value of different pigments. But these can never be of much help, and the reason is obvious. Taking any color, let us say Prussian blue, let a thin shade of it be lightly washed over white paper, and then a very deep shade. Photographing these, the first will act almost like pure white; the second almost like black, indeed, if made thick enough, as, for example, the cake of paint itself, it will be perfectly black. If, then, one color is capable of impressing itself of all shades from white to black, the assigning to it of any particular shade of half tint, must be purely arbitrary and altogether deceptive. So, if we attempt to compare two colors, let us say green verditer and raw umber. If the first be put on lightly, and the second thickly, the first will appear to be the more actinic color, and by reversing the proportion we shall reach an opposite conclusion. Precisely the same result will accompany the various shades of material used in dress. Experience, and intelligent observation of what takes place in the case of every portrait taken, will soon give a pretty exact idea of what effect any given costume will produce in the negative.

Velvet Drapery.—Salomon, the French portraitist, whose name is always necessarily cited in speaking of photographic æsthetics, avoids these difficulties by making appointments, and indicating to ladies what colors will be most effective for them. He also provides velvet drapery, with which he frequently covers and conceals the whole of the dress worn. The velvet which he uses is neither silk, nor is it black, but a dark purple cotton velvet, and its effects are often magnificent.

Posing the Sitter.—When a whole sitting figure is represented in profile, the point at which the back legs of the chair reach the ground will invariably and absolutely need to be supported. No rule is so commonly violated as this, and none with worse results, for the figure will always appear to be slipping out of the chair, because its lines want their due support. This it will not be always easy to give; the position is, therefore, especially for a male figure, an objectionable one. If for any reason it is especially desired, the photographer must introduce some object, such as a stool, best with drapery, or characteristic objects over or on it. With the female figure the difficulty is less, for its own drapery may be so disposed as to give the support required.

The position of the head of a standing figure with respect to the top of the card, produces a very curious influence on the

apparent height. If the print is so cut as to bring the head very near the top edge, a great impression of height is produced; if, on the other hand, the card extends far above the head, the figure is dwarfed. This effect is independent of the position of the figure with respect to other objects in the picture, and depends chiefly on the cutting of the card after it is printed. Therefore this principle may be used to improve the appearance of dwarfish or very stout figures, providing it be not carried to excess.

Want of attending to this effect produces in card portraits the most unintentionally ludicrous results. A man of average stature may be made to look seven feet or more high.

Mr. Petsch makes some excellent suggestions with regard to the overcoming of difficulties. Badly formed features he subdues by the arrangement of the head: a crooked nose is always most striking when seen from directly in front, therefore the head should be so turned that the side with the smaller surface is next the camera, and the larger surface is somewhat foreshortened. An irregular mouth, the line of which is not parallel to that of the eyes, should be similarly managed, the straighter end of the mouth is turned towards the camera, and the drooping end is seen less conspicuously, and is foreshortened. Those who squint are taken in profile. Very stout men are to be taken in three-quarter lengths.

Arranging the clothes has likewise much influence. Buttoning the coat adds breadth to the figure, opening it gives relief. Dark clothes diminish the size; light, and especially white ones, increase it. Defects in the head and face may be exaggerated by inappropriate ways of wearing the hair. To arrange the hair with ribbons, etc., at the sides, makes a broad face broader, but relieves the thinness of a long narrow one. A high head-dress exaggerates the length of a long neck, but relieves a broad face if kept front, otherwise if set far back. In profiles the hair should not be too flat on the top of the head, or a flat expression is produced.

§ 4.—Development in its Relation to Portraiture.

Some assistance can always be had in difficult cases by regulating the development. The writer has attempted, in papers written upon the subject of negative development, to demonstrate the true character and the rules by which it is governed, and as

a correct understanding of this is of much importance to the portraitist, a few words may advantageously be said on the matter here.

The stronger the developer, that is, the more sulphate of iron it contains, and the less restraining acid, gelatine, or sugar, the more rapid will be the precipitation of the metallic silver that forms the picture. *Just in proportion as the silver falls more slowly it is more subject to the attraction of the most strongly impressed parts of the silver.* In a slow precipitation the most strongly impressed parts of the film will get a larger proportion of the deposit than in a rapid precipitation. This fact, which has been thoroughly established both by theory and practice, is of the highest importance, and is the key to all the peculiarities of iron development in the wet way.

If, then, danger of a flat picture is feared, either by reason of—

1. An absence of contrast in the subject;
2. Too uniform an illumination;
3. A long exposure;

We should apply a weak developer, in order to increase the contrast.

On the other hand, if we have reason to dread a harsh picture from—

1. Excess of contrast in the subject itself;
2. Insufficient light;
3. Light badly controlled, so that it is excessive in places and insufficient in others;
4. Too short an exposure;

We should apply a strong developer to diminish the contrast by favoring a more equal deposit of silver.

The application of these principles to special cases is sufficiently obvious. If it is evident that the main difficulty of the work to be done will lie, for example, in getting relief and form into a quantity of white drapery, we shall need a slow development, in order that the faint shadows which are to give life and form to the white mass, shall not be overwhelmed by a rapid deposit of silver.

But if, on the contrary, it is specially desired to obtain detail in deep shadows, a strong developer will force the depositing silver to find all the faint impressions in these shadows and bring them out on the sensitive film.

A comparison of this section and the former will lead directly to the sufficiently obvious conclusion that exposure and development stand to each other in opposite relations.

And the general rule will be: If all the parts of the subject are actinic and well lighted, give a moderate exposure, and use developer No. 1, p. 162.

So, if all the parts tend to be non-actinic, or if the light is poor, give a long exposure, and use the same developer.

But if there is considerable contrast (and this is the more common case) so that some parts seem to demand a long and others a short exposure, and there is danger of too much contrast, then give a full exposure and use developer No. 2, p. 162.

It is not sufficient, however, to endeavor to overcome these difficulties, the difficulties themselves must to some extent be removed. Light must be so controlled that the illumination on the actinic surfaces must be restrained, and that on the shadows and non-actinic portion must be increased until the two can sufficiently be combined in one development.

§ 5.—Causes of Unsatisfactory Results in Portraiture.

1. *Too much Front Light.*

Excess of front light produces *flatness*. Light is too equally distributed over the projections and depressions of the face, so that these lose their character, and the face assumes an unmeaning expression, sometimes even a stupid or silly one. Such a light also throws, as Schrank has well remarked, too much illumination on the centre of the forehead, the ridge of the nose, the chin, and the cheek bones. What is worse still, it produces a bright reflection in the centre of the eye, precisely where the dark pupil properly appears, thus reversing the natural aspect, and at times giving almost the effect of blindness. Of all defects of lighting, excess of front light produces the most inartistic effects, and the most thoroughly displeasing pictures.

2. *Too much Side Light.*

Excess of side light produces a too unequal illumination of the two sides of the face, gives an excessive projection to the nose, and a hatchet shape to the face. The effect upon the eyes is sometimes very curious, causing them to look utterly unlike each other in consequence of the difference in the amount of light that

they receive. Still, the effects of an excess of such light are not so bad as those of excess of top or of front light. The best effects require a difference of illumination on the two sides, which may in skilful hands be carried to a very considerable extent. Nevertheless, it is easily overdone, and such attempts demand good management.

3. *Excess of Top Light.*

This error produces effects precisely the reverse of those of excess of front light; all the features become hard and projecting; a heavy frown settles on the brow; the eyes appear deep set and cavernous; the nose is enlarged, and any hollows about the mouth are greatly and unnaturally increased. A black shadow is produced directly under the chin, sometimes almost producing the effect of a beard.

4. *Too even Illumination.*

It is easy to fall into an error the reverse of all the foregoing by diffusing the illumination too generally. This is most apt to occur in operating under a flat, low glass roof, where the light comes in around the sitter from a variety of angles and directions. The result is a soft, characterless picture, which finds little favor, and deservedly so, whilst at the same time those unacquainted with the subject cannot tell why the picture is so unpleasing, for it is undoubtedly like the original, and there is no prominent objection to seize upon. At the same time there is the greatest of all objections, viz., that the portrait is totally devoid of merit, and gives the face with its least interesting and acceptable expression. The fault here spoken of is one that has received too little attention, some photographers refusing even to recognize it, and thinking, when they produce these pictures, that they are doing creditable work; they do not, however, find the sitter or the sitter's friends to agree very cordially with them.

5. *Insufficient Illumination below.*

When the illumination is at the same time chiefly horizontal, and yet is not carried low enough on the side, it may result that whilst the upper part of a sitter is well illuminated, the lower part is not. There results from this a want of detail in the shadows of all the lower part of the figure, a defect which can only be remedied by an alteration in the system of lighting.

6. *Insufficient Light.*

As it must always be the object of the operator to work well with a short exposure, a deficiency of light is one of the most serious evils to which he can be exposed. I may, for example, cite the case of a photographer in this city, who, after putting up a complete gallery, found his light so deficient that he was led to adopt the after-intensification of his negatives with mercury as a regular system—a bad and dangerous one every way, worse by far than even an expensive alteration in his defective glass room. His case was by no means a solitary one. It is far better, in constructing a glass room, to err by having too much light, the excess of which is so easily shut out, than to make the opposite mistake. When the mistake has been made, it is better for the professional photographer to recognize it at once, and remedy it radically by introducing more glass at any cost. In doing so, however, he should work neither at random nor in a hurry. He should first carefully ascertain by study in which description of light his glass house is most wanting, and proceed with a view to remedying that deficiency in the introduction of the additional glass. If his glass room has abundant top light, it would be folly for him to introduce his additional glass on the roof, and so on. The explanations already given will enable him to detect in what direction his glass room tends to err, and in arranging to admit more light he will be in a position to get exactly the kind of light which he most wants. Thus, in remedying a fault, he may, if he takes care and study, succeed in making his room better than if that fault had not been committed, for he may succeed in distributing his light more scientifically than if he had at first arranged to admit enough. It is in this, as in so many other cases in photography, the man who thinks carefully first over what he wants, and chooses, after reflection, that which is best fitted to afford the desired result, will always in the end succeed. One who can only learn through continual failures, will be weary before he can reach success. Every failure met with should be required to yield its fruit in the way of useful experience; and this should be made a fixed rule by every photographer.

§ 6.—**Backgrounds and Accessories.**

The subject of backgrounds is one of no small importance to the portraitist, and one often of no small difficulty. Without care, tact, and ingenuity, his productions are apt to be exposed to the imputation of sameness. Every one has become thoroughly tired of the column and the balustrade, which might as well now be banished once for all. The heavy curtain has also been a good deal employed, but it is too useful to be definitely dispensed with.

The end of the gallery should be colored of a soft bluish gray, and will form a useful background for taking groups of several persons. Special backgrounds usually consist, when plain, of colored cloth sold by the dealers, and which is usually stretched on a large frame furnished with feet, rolling on castors. These are of various shades, according to the effect desired. The photographer will need at least three—dark, light, and medium. Views are sometimes sketched on canvas stretched on similar frames. Considerable tact and skill are necessary for the production of really good pictorial backgrounds.

Sometimes a very beautiful effect is produced by having the upper part of the plain background lighter than the lower. This is especially useful in the case of three-quarter figures, or those which include from the head to the knees; the light part is made to correspond with the head, gradually softened opposite the shoulders into the dark shade of the rest. This calls attention to the head and throws it out, with an effect which, when well managed, is excellent.

Another useful effect which has attracted considerable attention of late years is that of inclining the background so that either side, right or left, shall be nearer than the other, taking care that the screen is towards the light, not against it. This method of proceeding has been very effectively employed by the celebrated Salomon, of Paris, and his mode of managing it will be seen by inspecting the adjoining sketch of his glass room. The sitter is turned somewhat towards the light, and the camera stands in the direction indicated by the arrow. The portion of the background nearest to the glazing receives the strongest light, which diminishes gradually towards the other end, producing an agreeable effect, which may be greatly varied by altering the position of the background and screens.

Fig. 104.

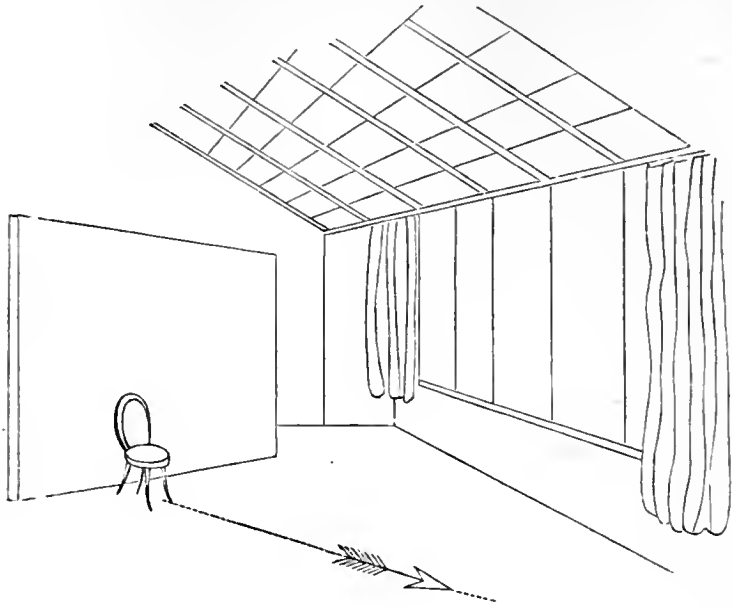

Large backgrounds should move on heavy castors made expressly for the purpose, and running on wheels of five or six inches in diameter.

Canopy Backgrounds.—The same photographer has for some years past employed a peculiar arrangement enabling him to obtain a great variety of effects, and dispensing with the necessity of employing blinds and curtains.

Fig. 105.

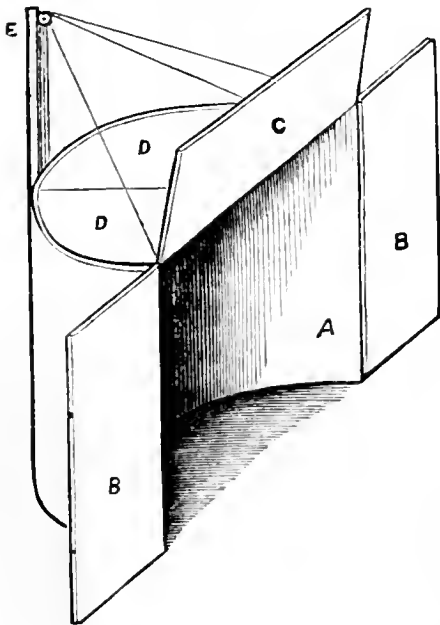

of employing blinds and curtains. As Salomon's work has never been surpassed, his modes of proceeding excite great interest; the writer annexes a figure copied from one published in the London *Photographic News*, after a drawing communicated by M. Salomon himself.

A is a semicircular background about 8 feet high, 10 wide, and 5 deep, from front to back. *B B* are folding wings, about 4 feet wide each, hinged to the background. *C* is a corresponding canopy, 10 feet long and 4 wide, hinged to the top. Another canopy, *D D*, covers the background itself: it is in two parts, hinged at the middle. The post *E* at the back carries a pulley at the top, over which pass cords connected with the differ-

ent canopies, and fastened at the back so as to be easily raised or lowered.

The semicircular background *A* is covered with wall-paper of a salmon color; it has three feet, not represented in the cut, which carry large castors. All the other parts, the wings and canopies, are light frames covered with thin transparent white muslin, allowing a good deal of light to pass, but softening any direct sunlight. At the corners, between the wings and the canopy *C*, the muslin of the upper canopy is continued out, so as to fill up the corner; this is not represented in the figure.

The sitter is placed in the centre of the curved part, and just under the front canopy, by raising or lowering which any desired amount of soft and diffused top light is obtained. So, too, the side light is regulated by opening or closing the wings. The illumination is farther controlled or altered by turning the whole contrivance on its castors, and thus exposing the open portion more directly to the light, or, on the other hand, turning it away. The curvature of the background affords gradation, and its form and depth tend to give relief to the figure, and even this may be very much modified by raising or lowering the upper canopies, *D D*, by which monotony and repetition of identical effects are avoided, and every grade of effect, from the lightest to the darkest, is easily obtained.

When a full-length figure is to be taken, the curve line of the background shows unpleasingly. A movable surbase or wash-board placed behind the sitter cuts off the curve and removes the difficulty.

The advantages of this system may be briefly summed up. Effectiveness, as it gives every variety of light. Adaptability: it may be either used in an ordinary glass room, or in a common room, as in the latter case it takes the place of blinds, curtains, and other machinery. Economy: that in use by M. Salomon cost him fifteen dollars only. To construct it two curved pieces of wood, for the top and bottom, are connected by thin upright boards, tongued and grooved into each other, whilst the wings and canopies are formed of light framework, covered as already described.

Conical Backgrounds, about which a good deal has been said, have scarcely answered the expectations that have been raised. The plan, also, of a *front screen*, coated white, and interposed

between the sitter and the camera, with an opening cut into it, has also proved unsatisfactory, in consequence of its tendency to produce flatness of effect.

Rotating Background.—Canvas is stretched over a flat wheel,

Fig. 106.

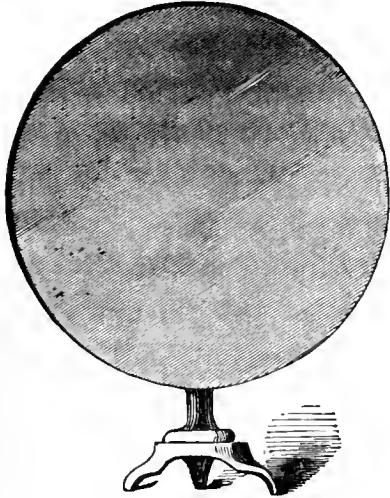

which, for lightness, consists simply of a round rim, connected, by wooden bars or spokes, with the axle at the centre. This canvas is colored of a warm gray or fawn color, shaded from one side to the other (see Fig. 106), so that there is a distinct but moderate difference of tint.

This background can be put to several uses. It may be set with the lightest portion uppermost, and used as a graduated background, the advantage of which has been already explained, or it may represent a lighter shade on one side of the sitter

than the other. Or, finally, it may be made to rotate during the whole sitting, and thus produce a perfectly even background, with a perfection of evenness obtainable in no other way.

The invention is ingenious and useful, but the writer considers it susceptible of a great improvement. If a triangular sector be cut out of white paper and attached in front of the circle, with its point at the centre, and widening towards the circumference, then, if the background be made to rotate, it is evident that the general effects will be *lightened*, and that in proportion to the width of the sector. Similarly, by using black paper the effect will be darkened. It is evident that, by having a supply of these black and white sectors, a single wheel may be made to produce an endless variety of shades of backgrounds, and always exhibiting a perfectly pure and even tint. All photographers know how difficult it is to obtain a plain background to their portraits that is absolutely free from blemish.

Distance of Background behind the Sitter.—Four or five feet is a common distance, but the practice varies much. Salomon makes his recede much more than most, and commonly places it eight or ten feet back.

It is common in photography to act on the principle that with a plain and indefinite background no furniture shall be intro-

duced; and that, on the other hand, if any furniture be visible, the background shall correspond and complete the room. This is, however, not so absolutely necessary as some suppose. For example, if a three-quarter figure be represented standing at the side of a small table and occupied in any way, as with papers, letters, flowers, work, etc., the picture may be finished with a plain, or, better, a simple shaded background, such as just described, and thus the photographer is relieved from the incessant use of a limited stock of combinations.

It is a most serious mistake to crowd quantities of objects, such as vases, urns, bouquets, etc., into the picture. This only results in distracting and confusing the attention. Certain points, where lines of direction reach the floor, or a table, or other object, often need imperatively to be supported by some object; this part of the subject will be treated of more particularly hereafter. A foreground is often relieved by characteristic objects, grouped, not scattered. But then they require to be handled with taste and according to rule, and must never be strewn about or huddled together promiscuously. Particular care should be taken to avoid brilliant reflections of light from accessories, and for this reason such objects should have dead, and not reflecting surfaces. Anything, in fact, that tends to make them conspicuous, distracts the attention from the figure itself.

In some photographs the figure itself is quite a subordinate affair, being completely subdued by dazzling furniture and by crowds of vases, bouquets, and other objects, placed in the most unnatural and improper positions. Sometimes the very first thing that catches the eye is the pattern of the carpet, composed of ill-assorted figures and inharmonious lines. Such mistakes as this last are doubly unfortunate, as they tend to repeat themselves through a large part of the photographer's work. Generally speaking, any object that must appear in many pictures should be extremely inconspicuous, and this holds with nothing more than with the carpet, if there is one.

A vignettted bust undoubtedly possesses advantages over any other description of photographic portraiture: it is that form in which the shortcomings of our methods are best overcome. It may, therefore, be doubted whether, in the introduction of the cabinet size, it has been wise to endeavor to exclude the vignette. The whole plate vignette heads which were formerly made, and

are now so rarely seen, were far more effective than the little card heads that have taken their place.

When pictorial backgrounds are employed, it is necessary that the lens should be directed at the point of sight; that is, at the point to which, in the drawing of the background, the spectator's eye was supposed to be directed, namely, the point at which the line of vision cuts the horizon. If, as may happen, this point is not very easily distinguishable, the lens should at least be directed at the horizon line of the picture. Or, what is still better, the horizon line should be completely concealed by a skilfully arranged design. If neither of these precautions be adopted, there will be no illusion whatever, and this is why the effect of fanciful backgrounds is so rarely good.

Good effects may be obtained by using a background of brown paper, shading it off with white crayon in a light and sketchy way. If it be desired that the print shall show parallel strokes of shading over the shoulders and round the head, in imitation of crayon drawing, it is evident that this result can be attained by marking on the background a central spot for the head, and sketching large, coarse shading around it. In this case black crayon or charcoal should be used on a light buff ground. Such backgrounds will need to be in sliding frames, balanced with weights, that they may be raised or lowered to bring the centre into exact correspondence with the head.

The appearance of the grain of drawing-paper is sometimes given to the finished and mounted photograph by passing it, before quite dry, through a press, together with a piece of coarsely grained paper laid on the surface of the print.

CHAPTER VII.

LANDSCAPE AND ARCHITECTURAL PHOTOGRAPHY.

§ 1.—General Remarks.

LANDSCAPE photography is a very fascinating pursuit; and when once undertaken in good earnest, and pursued to successful and satisfactory results, is not often or easily abandoned.

The first need will be to possess a good camera and good lenses.

The subject of lenses having been already discussed, the writer will here simply repeat his conviction that for views which do not include architectural subjects, the view lens is not easily excelled, at least when its too small angle of view is remedied as in Dallmeyer's wide-angle view lenses. Used with equal stops, these lenses have greater depth of focus than any others that the writer has tried. The Steinheil aplanatic gives very harmonious landscapes and renders architectural lines correctly.

It is important to repeat here that the best effects will never be obtained with lenses of too small focus. Under their influence, landscapes become so altered as to be unrecognizable. Buildings, in place of seeming to stand upon a firm foundation, seem to totter forwards. Rectangular corners are made to assume the appearance of sharp angles, so that the building no longer appears square, but lozenge-shaped. The upper corners of the roof look high and peaked, and the real character of the edifice is lost.

Levelling the Camera.—When architectural subjects constitute the picture or are included in it, the camera must always be levelled, or the lines of the building will not be straight in the image. The level may be either rested on the camera, or, what is better, it may be countersunk into the camera, and so remain permanently attached to it. To make this arrangement, the camera should be placed on a perfectly level surface, ascertained to be such by careful levelling. The "universal level," which is round, and about an inch or an inch and a quarter in diameter, is then permanently fastened into its opening with shellac cement, and so placed in it that the bubble shall be central.

Of course, where a building is so unfortunately situated that a view cannot be obtained except with a very short focus lens, its use will be excusable, but the result will never be satisfactory.

It sometimes happens, also, that buildings in narrow streets cannot be photographed except from the second or third stories of opposite houses. Such pictures are inferior to those obtained from the ground, and always give the idea of being taken from some unnatural point of view. It is unfortunate that buildings in cities are generally so situated that no first-class photograph can be obtained of them, owing to the narrowness of streets and crowding of houses.

With landscapes this levelling is less necessary. To obtain a perfectly truthful representation, it is essential, and therefore no view can be accepted as giving an accurate delineation of scenery

unless the camera was levelled when it was taken. But in taking views simply as beautiful objects, more latitude may be allowed.

§ 2.—Choice of Conditions.

As landscapes are always seen with disadvantage under a noon-day sun, so photographs taken under similar circumstances are mostly unpleasing; and as photography tends to exaggerated contrasts of light and shade, the result is all the worse. Many experienced landscape photographers therefore avoid bright days, and like best of all those times when the sky is covered with white clouds through which the sun occasionally breaks. If a glimpse of sun can be secured at the end of an exposure, the best of all effects is got, and this may be compared to the effect in nature of the softened sun late in the afternoon, and we all know the magical influence of such light even upon the tamest of scenery. It is therefore a good plan, if there is hope of a burst of sun, to cover the lens a little before the proper exposure has been given, and then, when the sun comes, to expose for a moment, and so light up the picture without getting harsh contrasts. These last may, in extremely bright weather, give an effect of snowiness in the high lights, which is in the highest degree displeasing.

The time during which the lens may be covered to wait for this sun will depend upon the weather. In moist or cool weather much more time may be prudently allowed than in hot or dry. Great care should be taken not to disturb the camera in opening and closing. For this, the morocco lined with velvet caps, now furnished with all the best lenses, are very recommendable, and work better than the common brass caps.

As the sky is apt to be over-exposed, it may often be advantageously shaded during part of the exposure. This may be done by holding the hand or other object in front of the upper part of the lens, and near to it, moving it continually. To accomplish the same object, sky-shutters are often made to the lens or to the camera, but it is difficult to use them without disturbing the camera. In landscape taking, the photographer will avoid the use of the two smaller stops. The object of the stop should be clearly understood. In the case of the view lens, it is to obtain depth of focus, to have the distant and the moderately near objects simultaneously in focus. With the doublets and the

view lens, diminishing the size of the stop improves the definition and crispness at the margin. When these objects have been sufficiently attained, no further diminution of the stop is advisable, as the image loses in character and boldness, in addition to which the time of exposure is of course increased.

All the most experienced photographers are agreed that a view should invariably be taken with the largest stop that the conditions of the case will permit. As soon as a satisfactory definition is obtained, further reduction of the stop should be avoided with the utmost care. A small stop produces a flat picture, without gradation of distance or atmosphere. A large one gives a bold, clear view, with the objects in the respective planes of distance well made out. Objects that with a small stop seem pressed together, with a large one stand well out and show what they are. The photographer cannot be too strongly enjoined not, in order to obtain a microscopic sharpness, to sacrifice the general character and expression of his view. Of course, good definition cannot be dispensed with. But when the operator finds that he cannot get this without a very small stop in using any of the ordinary forms of lenses, he may be sure that he is straining the lens, making it do work for which it is unsuited, and therefore that he cannot expect the best results.

A photographer may visit scenes of great natural beauty, and may be deeply impressed by them. He may labor very hard to reproduce them in his negatives, and yet, after much effort, he may obtain but unsatisfactory results. Some will, under these circumstances, lay the blame on photography, and affirm that the indifferent results spring from the incapacity of the method to yield what is wanted. Others will not perceive the deficiencies of their own pictures, and think they have all that can be expected; whilst others, again, with a truer sense of the beautiful, will be disheartened by the difference between what they have seen in nature and what they have been able to carry away. But this is in reality the first step towards ultimate success. A keen appreciation of errors and imperfections gradually helps to avoid them, but not without many failures and much persistent effort.

In viewing a landscape in nature, the eye is apt to seize and rest upon the characteristic features, overlooking those that are secondary. A lens cannot do this, and, singularly enough, the eye will not do that with a picture which it will with real objects,

but insists, as it were, that the picture should represent them as they should be. This fact is so conspicuously true, that examples are scarcely necessary. They will, however, continually present themselves to the photographer. Perhaps the view lies in a wild valley in the midst of hills, and the scene is not marred by the presence of a rustic cottage. But perhaps beside it are lines hanging full of clothes drying. This the eye passes over and excuses in *the scene itself*, but the same feature introduced into any picture, photographic or otherwise, provokes inextinguishable laughter.

So with the hideous telegraph poles that line all our roads and railroads, and intrude into almost all our scenery. The eye consents reluctantly to forget them by an effort, and to consider the scene without reference to them, and to some extent succeeds. But in the photograph they come out straight, stiff, and prominent. Even the wire is perfectly made out. It results that often a scene cannot be taken from its best points by reason of these detestable adjuncts, and that, because of their continued repetition at short intervals, the effort to wholly exclude them becomes totally unavailing. Telegraphs are necessary things, but there is no reason that they should be permitted to intrude through scenery of recognized natural beauty. This is carrying utilitarianism too far, and would be tolerated in no country less corporation-ridden than ours. Six miles of the scenery of the beautiful Wissahickon are in this way marred by the poles that carry a wire apparently for individual convenience, which might better dispense with it, or choose another route.

As the camera has not the painter's power of excluding or subduing intrusive objects, all that the photographer can do is to endeavor so to select his point of view as to avoid them. This is a matter that deserves more pains to be taken than it mostly receives. After the view has been taken, it will sometimes be found that a change of position of even a few yards only would have made a material improvement; a discovery mortifying and annoying, and better avoided by a careful search beforehand.

A question will often present itself as to whether any particular view will give the best effect if taken on a plate with its longest side vertical or horizontal. The writer has elsewhere pointed out that this question is best answered by observing what

is the direction of the *principal object* in the landscape, and making the greatest dimension of the plate correspond with it.

Thus, a dam will for the most part look best in a wide picture, whilst for a narrow and high waterfall the greatest length of the plate should be up and down. So, too, where the chief object is a tree or a group of trees; whereas with a bridge the principal dimensions should be right and left. But no such rules can be an absolute guide, it will only aid in deciding, and if any doubt is felt, an excellent plan is to try it both ways; on inspecting the prints no doubt will remain as to which was the best position, and the comparison will aid in forming a correct judgment on subsequent occasions.

In a landscape, the best effects are to be secured by *contrast*. In photography, as we have no effects of color, our contrasts are limited to those of *line* and those of *light*.

Contrasts of line or form are always relished by the eye. The effect of the mountain is enhanced by the levelness of the plain at its base. A picture that should represent a plain with no elevation, or simply an elevation with no plain to contrast with it, will always be deficient. Other and beautiful contrasts of line are often seen in a rolling country, even where there is no plain and no great elevation.

Contrasts of light and shade, technically called *chiaroscuro*, are the life of all pictorial representations. They give us, in a great measure, our ideas of the form and relative position of bodies. Negatives taken in dull weather are necessarily deficient in this quality, whilst those taken in clear sunshine often present contrasts too harsh. A weak sun often gives beautiful effects, and as the sun is less powerful when low, this, as well as many other advantages, is obtained by working at such times.

Whilst contrast is all-important in photography, it is to be carefully remembered that too much of it is even worse than too little.

If a negative be taken with insufficient exposure, and then this be attempted to be made up in the development, it will most frequently happen that the silver, instead of being deposited so as to keep the regular graduation of tone, falls too much upon the lights. Thus the picture becomes *hard*, and if the fault has been great, it becomes *snowy*.

In some classes of subjects, snowiness is not easily avoided.

If a landscape be in part very brightly, and in others very badly, lighted, the photographer finds himself in the dilemma that either he exposes and develops too long for the one part, or too briefly for the other. In printing his negative, he may find an absence of detail, accordingly, either in the lights or shadows. This difficulty is inherent to the nature of the subject, and may be too great to be overcome. The best advice that can be given is to give a full exposure, compensating for this by using a rather weak developer, and letting it lie quietly on the surface of the plate, without sending it to and fro. The collodion should contain a rather full proportion of bromides. This checks contrast, so much, indeed, as to render such collodion unsuitable for views in which the contrasts are less striking. Some careful operators carry with them two sorts of collodion, using the most highly bromided for mastering contrasts. Those who are not willing to take this trouble, find themselves obliged to avoid such combinations, and to return to them in sunless weather. Where much bromide is used, it should always be borne in mind that the negatives will prove in printing more transparent than they appear to the eye.

In taking views along streams with high banks, and in ravines, the contrasts of light and shade will always be really greater than they appear to be, and due allowance must always be made for this. In such places the shadows are apt to be very dark, because so much of the sky is cut off, and it is always the diffuse light from the sky that lights up the shadows. In such places it will be found difficult to combine darkly shaded foliage with sunlight in the same picture; this result can only be obtained by prolonged exposure, and slow and careful development; generally it will be best not to attempt it, if it can be avoided.

The development must always be graduated not merely with respect to the character of the scene, but to the amount of exposure that has been given. In order to combine exposure and development, and so to get the best possible results in difficult cases, the following observations may be useful.

A view that is strongly illuminated all over, with few contrasts, will demand a moderately short exposure and a long development with a weak developer, the object being to preserve detail, and yet at the same time to retain contrast enough to give life to the whole.

When the illumination is uniform and not good, or where all the objects are non-actinic, and the light not very good, we shall want a very prolonged exposure to get them well impressed. And then we shall need a long development with a weak developer, otherwise the result will be tame and flat.

In this country the character of the light varies between extremely wide limits. In cloudy weather there is apt to be, of course, everywhere, a deficiency of contrast. Such light, however, is often very favorable for taking near foliage. On the other hand, when the sun shines, the light is apt to be very powerful, and as the air with us in clear weather is apt to be very transparent, it results that the shadows are dark and wanting in detail. In clear, cloudless weather the shadows are very dark, and in such weather it requires great experience and very good management to get first-rate effects. Attention must be paid to the influence both of the *season* and of the *time of day*.

Seasons.—The landscape begins in this latitude to show sufficient foliage to commence photographic work towards the first of June, though the forest trees are not well in leaf till a fortnight later. At this time of year the light is exceedingly powerful, and exposures must be shortened.

A slight excess of exposure, generally unimportant, will sometimes give rise to solarization. A good deal of care and circumspection will be required. Sometimes, when the sky is covered with low white clouds with the sun just breaking through them, the power of the light is truly amazing.

Throughout the spring and summer, the days when the leaves are still are far from frequent. In September, and even towards the end of August, the air is much quieter, and it is far less difficult to find favorable days; the light is also softer. On the other hand, there is more dust, and streams are apt to be low, so that waterfalls show but scanty streams, and mill-dams, often very beautiful at other times, are frequently quite dry.

A serious trouble at all seasons, in our climate, is the want of softened light. We have but a few of those partly overcast yet luminous days which give such beautiful effects of illumination and such soft foliage; our light is mostly too abundant and piercing.

Snow Landscapes should receive a medium exposure and a full development, for, to obtain clean, bright snow scenes, all the

most fully lighted snow must be developed to absolute opacity, shading off, however, to give it relief.

Time of Day.—Two or three hours after sunrise the light is very powerful; it goes on to increase till about 11 o'clock, then remains stationary till 12, after which it diminishes till sunset. The afternoon light is always weaker than the corresponding part of the morning. Thus, the light two hours (for example) before sunset is not half as powerful as two hours after sunrise, though the sun in both cases is equally high. This is said to be caused by the greater quantity of moisture dissolved in the air, though the explanation is doubtful.

Cloudless weather is always unfavorable. Clouds act as reflectors to light up the shadows. In cloudless weather the shadows are always very dark, and are apt to want detail in the image. In such weather, the middle of the day is, in the writer's opinion, very unsatisfactory for work. In the early morning, and in the afternoon, the evil of want of clouds is less felt. At these times, also, the effects of scenery are more agreeable, the shadows are longer and give more relief, the air is generally stiller. Longer exposures are necessary, of course, but the results are better. In overcast weather, the middle of the day is apt to be the best time.

Cast Shadows are such as retain more or less of the form of the object that casts them, as distinguished from the more indefinite shadow that comes from some less distinct source. Such shadows are often the source of exquisite beauty in landscapes. A level foreground of grass is apt to be flat and unmeaning; the shadow of a tree cast across it, gives it at once life, character, relief. The landscapist cannot pay too much attention to such effects of foreground.

Generally, the more that shadow is *diversified* the finer its effect. A large dark shadow of a tree is far less beautiful than one in which the sun penetrates the leaves, and falls in irregular, broken forms upon the ground.

When it is required that a house shall appear in the foreground, a diversified shadow upon its walls has an extremely good effect. In neither case, however, must the lights and shadows be too much broken, or the effect will lack breadth. And the greatest care must be taken to avoid spottiness of effect. As this is a

common and fatal fault, the writer will endeavor to point out its source.

Shadows of branches and boughs through which the sun penetrates partly, and which retain indistinctly the forms of leaves and sprays, are very beautiful. A level sun will often throw shadows of such sprays upon the trunks of trees, with an exquisite effect. So shadows of leaves and boughs on walls, houses, roads, and grass, are often very beautiful. But it is an essential condition that *the shadows must be transparent, and shall present only a moderate degree of contrast with the lights*. If, however, we place the camera in a grove and take a picture, we shall probably get black shadows on the ground, interspersed with white patches of sunlight, and these effects, instead of being of a wholly subordinate character, will strike the eye before anything else in the view. Such an effect is indescribably bad, and to be avoided with the utmost care.

Parallel patches of shadow are especially ugly. These are apt to occur when trees present themselves in rows, with sunshine penetrating between each two trees.

The tree, the great beauty of the landscape, offers peculiar difficulties in photography, owing to the non-actinic color of its leaves. For this reason it has been thought advisable to use much bromide in collodion intended for landscape photography; the true explanation of its utility has been already given. There is a remarkable difference between leaves of different trees, which it will be necessary to bear in mind. Some have a brilliant surface, as if they had been varnished; such are the sour-gum, black-oak, and others. From this we descend through every degree to those leaves which scarcely return any light, such as the white-oak, &c. The first sort, if in direct sunshine, are apt to produce a particularly disagreeable effect; they send back so much light, that they develop to full opacity by the time the rest of the picture has come up to printing strength, and so print quite white. This is unnatural and unpleasing, and, as far as possible, to be avoided. In cloudy weather such leaves photograph exceedingly well. Ivy-leaves on buildings easily give a very beautiful effect. They send back a good amount of light and not too much, and, as they are apt to look all in the same direction, each leaf is bordered by a shadow. Thus each leaf is well made out, and the effect is particularly pleasing and exceedingly easy to catch, more so, perhaps, than with any other sort of foliage.

It has been often advised in photography to have the sun well behind the camera. This, however, is a rule of very doubtful validity. When the sun shines full upon a group of trees in the middle distance, the forms of the individual trees are never well made out, and the result is apt to be a mere mass of brilliantly lighted foliage. Often the separate twigs and boughs may stand out in consequence of dark shadows falling between the leaves, but the beautiful rounded effect of each particular tree is only well thrown out by a good side-light. This inferiority of effect produced by having the sun directly or nearly behind the camera, on trees in the middle distance, is very striking. *Near foliage*, however, bears having the sun behind the camera perfectly well. But the exquisite beauty of the rounded forms of individual trees in the middle distance is only well rendered by a side-light.

One reason why this light from behind has been extensively used is that it is the least exposed to *blurring*. Whenever dark masses stand out against a bright sky, the light has a tendency to get round and intrude upon the shadow; an effect that arises from reflection from the back surface of the glass. The partial opacity of the film scatters the light that passes through it in every direction, so that portions reach the back at very oblique angles, and may return to the face at considerable distances from where they entered. To a large extent this may be avoided by wet red blotting-paper on the backs of wet plates and glycerine plates (a precaution which should *never* be neglected), and by painting the backs of dry plates.

Near foliage should be represented invariably in half-tone, and this effect is generally obtained more easily when the sun is not too bright, especially in the case of the polished leaves already spoken of. Distant foliage is far more easy to manage, and bears the brightest sunshine perfectly. It is far better rendered when the sun falls upon it from the side than when the sun is either nearly before or nearly behind the spectator. A fine single tree or grove of trees lighted from the side affords a beautiful play of light and shade, which disappears when the sun is in the line of view before or behind, or even approaches to that direction.

Natural clouds are a great beauty when they can be included in a landscape. The difficulties here are twofold. It is not very common (at least in our climate) that there are clouds such as it

is desirable to take. In our fine weather we have mostly a clear or nearly clear sky. And when there are beautiful clouds, the weather is apt to be too windy for photographic work. But the greatest difficulty lies in the fact of the great luminosity of clouds. When the sun is shining, the *darkest part* of a cloud is generally *more* luminous than the whitest object in a landscape. The eye scarcely realizes this in observing a landscape, but it is easily recognized on the ground glass. The consequence is that although the clouds appear in the commencement of development, yet they are buried in a mass of deposit before the details of the landscape are got.

There are several methods of obviating this to some extent, though it must be confessed that they leave much to be desired.

The camera may be provided with a *sky-shade*, a shutter in front of the lens (Figs. 92 and 94), which may be slowly raised during exposure, so as to diminish the light admitted from the sky.

Or the hand, the hat, or the shutter of the plate holder may be used in the absence of a sky-shade.

In either of these cases a trial should be made of the movements beforehand, and the effect watched upon the ground glass, that the operator may see in what position of the shading object the sky begins to be uncovered.

The inclined diaphragm (Fig. 40, p. 66), by reducing the light from the sky, will aid in obtaining clouds.

To secure clouds, the opportunity also should be favorable. The landscape should be wide and well lighted, in order that a brief exposure may suffice for the terrestrial objects.

According to Mr. H. T. Anthony, a developer of double sulphate of iron and ammonia 30 grains to the ounce, sulphate of copper 5 grains, and acetic acid as needed, is very favorable to the obtaining of clouds.

An agreeable diversification of the foreground is a capital point in a landscape. It has been already remarked how much this is aided by shadows. Almost any characteristic and prominent objects will have a good effect; logs, stones, and, still more, rocks, bushes—anything that breaks the level and changes the lines, also attracts and pleases the eye, not in itself, but in the general character that it imparts. It may generally be affirmed that scarcely anything can so much detract from the effect of a landscape as an unbroken foreground, level in form, and uniform

in light. Such a foreground will mar, if not destroy, the effect of the finest objects. The artistic photographer will always change his position to avoid such a foreground; or, if he is tied down to a particular spot from some imperative cause, he will, if possible, have some object, such as a log, a large stone, or a trunk of a tree, thrown where it will support his lines, as explained more fully beyond. High banks are very picturesque objects, and often aid to make beautiful foregrounds.

Bringing Out the Foreground. Acceleration of Exposure.—Often the foreground, especially if consisting, as it so commonly does, chiefly of foliage, lags behind in development; and when some other parts of the picture have reached a full intensity, so that the development must perforce be stopped, the foreground will often be still thin and poor. This is a great injury to a picture, which is helped by nothing more than by a properly exposed and developed foreground.

The writer has succeeded in obviating this difficulty to a considerable extent as follows: He takes a piece of white pasteboard,

Fig. 107.

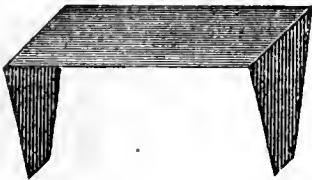

shaped as in Fig. 107, and of such a size that whilst the top lies flat against the inside top of the camera, the tapering sides rest upon the bottom, and act like legs to support the top in its place. The inside is colored rose-red with carmine (lump carmine, a grain or two dissolved in half an ounce of water,

with a drop or two of liquid ammonia, is better than the paint). The red light diffused and reflected by the surface of this paper considerably increases the force of the adjoining portions of the image, without in the least tending to produce fog. The sides should taper very much, as it is not desirable that any part of the red paper should be alongside of any part of the sky.

There is in this device a real and solid utility, and the writer never now goes out to take views without this adjunct. A piece of pasteboard blackened with ink, and of such a size as to fit against one of the sides of the camera, and so cover one of the legs of the red pasteboard in case there is much sky on that side, is convenient to have.

§ 3.—Materials.

Camera.—The most convenient form of camera for ordinary use is that represented in Fig. 94, p. 149, except that, especially if the camera be large, the writer prefers the wooden brace shown in Fig. 92. When it is intended to pack the camera, to carry to a distance, it is convenient to have the bottom jointed and hinged, though this system weakens the whole construction.

Slides.—If the dry process is worked, the photographer can use *Changing Boxes*, contrived to carry a number of plates, and transfer them, one by one, to a peculiarly made slide; or he can use separate slides, which may be made to carry two plates each, and are then called *Double Backs*. This is the plan preferred by the writer.

Tripods.—A light folding tripod is essential for field work; and as much of the photographer's comfort will depend upon having a good tripod, the writer has made drawings of the parts of the form which he prefers.

Fig. 108 shows the top table. It is made of three thin pieces of wood glued firmly together, and having the form of a rounded triangle. At each corner a block is fastened underneath, carrying stout pins, *A*, *B*, which slip into holes in the legs, the tops of which are shown in the figure.

Fig. 108.

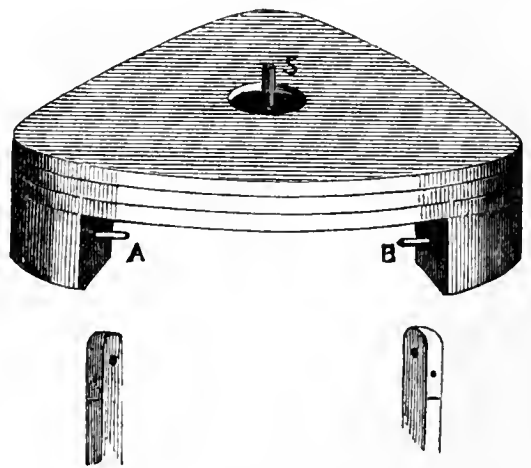

At the centre is a circular opening in the top thickness, in the middle of which circle is set the screw *S*. There is no screw-thread in the table, the screw merely passes through it and screws into the camera. A pin passed through the stem of the screw, just above where it passes through the table, prevents it from dropping out; this is a great convenience, often neglected by the makers, thus subjecting the photographer to the chance of overlooking the screw in going out, and so losing his day.

The legs, one of which is shown in Fig. 109, fold over in the middle, to save room. The cross-piece near the upper end moves on a hinge, and permits of shutting the whole up flat. In Fig. 110 the writer has drawn the joint on a larger scale. When the

leg is straightened out, a small brass cross-piece, attached by two screws, confines the lower piece in its position, and a strong thumb-

Fig. 109.

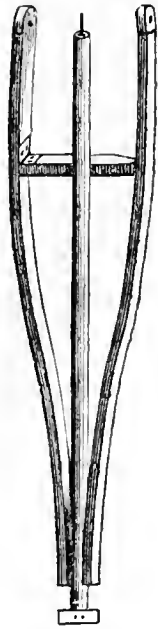
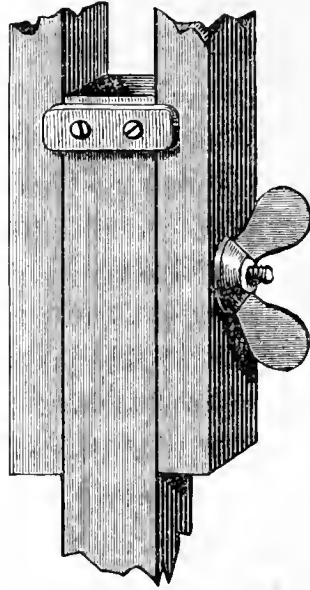

Fig. 110.



screw at the side, when tightly turned, makes the whole perfectly rigid. It is surprising how light a tripod, thus made, will hold a heavy camera quite steady.

For additional information on materials, see Chapter XV.

§ 4.—Manipulations in the Field.

If the wet process is the one selected, the photographer will either use a *developing box*, a *tent*, or a *dark room on wheels*. One of the simplest tent contrivances is a thick black cloth stretched over the camera tripod, and kept in place by stones. In the developing box, the hands and arms only are inserted into sleeves, whilst the operations are watched through yellow glass.

All the troubles, and there are many, that accompany these methods of operating, are avoided by the use of dry plates. And it is certain that the most improved methods of dry plate work give results fully equal to those of the wet process.

Whichever method be adopted, an observance of the following rules will save a great deal of vexation and the loss of many negatives, occasionally perhaps of a whole day's work.

At the commencement of a day's work, see, once for all—

1. That the camera is light-tight, and that there are no cracks in the front or holes in the bellows body. Cap the lens, cover in

the head well, and look into the camera with the ground glass let down, racking back pretty well, to open the folds of the bellows.

2. See that the lens

Is free from dust.

Has no dew on it.

That the parts of the lens and of the mount are properly put together.

For each exposure make sure.

3. That the camera and tripod are *perfectly* steady.

4. Invariably use the largest aperture to compose the picture. Make sure that no near objects out of focus are showing in the foreground, which may easily happen with shrubs, weeds, and the like. Also that no overhanging foliage is intruding upon the upper corners of the plate, to appear, to the dismay of the photographer, when he develops, as large, formless objects, ruining probably his picture.

5. Adjust the swing-back. Remember that if the screws which fasten it are not turned perfectly tight, *they will probably move* when the plate holder is pressed up to attach it.

6. If working with dry plates, make perfectly sure that you are not exposing a plate that has been already exposed before. If habitually using dark slides or double backs, have each painted conspicuously with a number on the shutter, and expose in regular rotation. If using a changing box, adopt a regular system of changing the plate immediately after, or immediately before, exposing; always the same.

7. If the sliding front has been moved up or down or sideways, for a previous exposure, make sure that it has been replaced. If the camera has been carried a distance, the front may have jolted down, and if not attended to, some of the corners may be defective in the image.

8. After arranging and composing the picture with the largest stop (in order that you may see exactly what the picture will be like), *turn the screw of the tripod under the camera, hard*, so that there shall not be the slightest change of position during the subsequent manipulations.

9. Now put in the diaphragm which you intend to use, and focus with it (never with the large one by which the picture was composed, and for two reasons: 1st. It will not give a good focus, being too large. 2d. If it did, its focus *would not be the same*, the smaller the stop the longer the focus).

The loose diaphragms that slide into slits in the tube (Waterhouse diaphragms) are apt to drop out. To avoid this, *bend the shank a little*.

10. Uncap the lens gently, pausing at the moment, to insure perfect rest.

11. Watch the foliage intently during exposure, and at the slightest sign of movement, replace the cap until the movement wholly subsides, and repeat this as often as necessary—a dozen times if needful.

The same objects will appear so differently in different lights, that the painstaking photographer will not hesitate to wait or to return when he finds the illumination to be unsuitable for his purposes. There is a story told of a distinguished landscapist that he once waited three weeks to get good weather and a particular effect of light upon a scene that he had come to photograph. There is some contrast between this and the rapid worker who points his camera at everything that catches his eye, and exposes his dozen of dry plates in an hour or two. It should be laid down as an axiom by every worker, that a *good* negative is *very* valuable, a tolerable negative worth absolutely nothing. It is at least as troublesome to print a tolerable negative as a good one, and the prints from the tolerable one are not worth the pains they have cost in printing. Twenty copies from a good negative are valuable for exchanging against prints from good negatives belonging to others; but twenty prints, each from a tolerable and different negative, are nearly worthless. No multiplication of indifferent results will give good ones, and the experimenter will derive more satisfaction from a single thoroughly good negative than from a score or a hundred of indifferent or tolerable ones. Good results will come only with care, thought, close observation, and a resolution to have things right at any cost of time and trouble. Care-taking soon becomes a matter of course, and the habit once acquired, is invaluable.

Adapting Flanges.—The inconvenience arising from flanges of different sizes has been already pointed out (p. 96). The writer finds this annoyance materially lessened by having adapting flanges made for lenses, so that several lenses may screw into one and the same flange. Such adapters can readily be made by any optician at a trifling cost.

Focussing.—A black cloth which will perfectly exclude the

light is essential. Black waterproof is suitable, and a piece a yard and a half square will be a convenient size.

Photographers differ very much in their ideas of how a focus should be taken. In the first edition of this manual it was recommended to focus at a point in the foreground half-way between the centre and a corner, racking back as far as practicable, and then putting on a small enough stop to obtain the definition needed.

Now, however, the writer has gradually adopted the following plan: There will be with any lens a stop which one habitually uses when the objects are not very different in their distances from the camera, and another, the next smaller, used when the differences are greater. Therefore, selecting for the view about to be taken the stop deemed appropriate, proceed to focus on the distance, and then rack back the focussing screen just as long as the distance will bear it, without its definition suffering too much. This ought to bring the foreground into focus; if it does not, a smaller stop must be substituted, or else the position changed so as to exclude the near objects that cannot be got into focus along with the distance.

Either of these alternatives is unsatisfactory, because it may be very desirable to include that particular part of the foreground, and a small stop is always bad.

But if the camera have the valuable aid of the *swing-back*, the question is greatly simplified. The photographer will be enabled to get an equally good general focus with a larger stop, and consequently with better detail in the shadows, and better spacing out of the distances. A swing-back should always be double, that is, have both a horizontal and a vertical motion.

The *vertical pivot* is to be used when, as so often happens, the objects at one side of the view are nearer than those on the other. The side on which the nearer objects fall is drawn a little away from the lens.

The *horizontal pivot* is useful in getting the foreground into focus at the same time with the distance. To this end, focus on the distance, rack out the focussing screen as long as the distance will bear it. Then draw the top of the screen away from the lens, until the foreground is perfect. Both this and the vertical action may be combined (see also p. 148).

The usefulness and convenience of the swing-back for bringing the foreground into focus is exceedingly great, and when once

used habitually, this contrivance is felt to be indispensable. There is one case, however, in which particular caution is needed in its application.

If both the upper corners of the picture be occupied by near foliage, then any drawing out of the upper side of the swing-back to regulate the foreground will be apt to throw the corner foliage out of focus, and deform it. In such cases it will be needful to move the tripod farther back in order to lessen the difficulties of the position.

If one upper corner only be covered by foliage, and if the extreme distance of the view lie towards the other end, we may then draw out the foreground without danger, because the foliage in the upper corner can be got into focus again by regulating the vertical pivot, and thus at the same time the distance at the farther side will be also harmonized in focus.

Some persons are as anxious for sharpness in the distance as in the foreground, and will exhibit a print with the boast that the extreme distance will bear a microscope. As the eye cannot see natural objects in this fashion, it can scarcely be right to depict them so. And when we examine the works of the great masters of landscape painting, we find that, with the power to draw their distances precisely as they pleased, they did not think right to make them sharply cut.

We find that, as distance softens down outlines to the eye, so when outlines are softened down, the eye infers distance.

Not that this principle is to be carried to excess, and made an excuse for blundering work. It is only that the same sharpness is not to be exacted in the distance as in the foreground; especially as this can only be attained by the use of a very small stop, which greatly mars the boldness and life of the image.

§ 5.—The Wind.

In all landscapes the chief beauty lies in the foliage, and it is necessary that this should be absolutely still, to be satisfactorily represented. Every one who attempts landscape photography has had severe experience of this sort, and fully understands the ruinous effect produced upon a picture by blurred masses of leaves.

It would be difficult to exaggerate the annoyance caused to the

photographer by this unending source of trouble. It is impossible to foretell what the prospect of wind is, therefore a long excursion may be taken uselessly, or may be abandoned only to see, when too late, the wind entirely subside.

The following represents what aid can be given in this direction:—

Time of Day.—The very early morning is apt to be calm, and, still more so, the afternoon for an hour or two before sunset. Both of these are excellent times for photographic work. The exposures in the late afternoon are necessarily prolonged, but the quietness of the air generally makes this easy.

Between eight and ten o'clock A. M. the wind is apt to rise, sometimes earlier, sometimes later. It may subside towards midday, but quite as often not. Gradually towards three or four o'clock in autumn, four or five in spring and summer, a subsidence may be hoped for, and then no time should be lost in improving it. It is one advantage of dry plates that they can follow each other without losing valuable time in sensitizing and developing; the collodio-bromide dry plates hereafter to be described are, by reason of their sensitiveness, excellent for afternoon exposures.

Seasons.—The spring with us is apt to be windy, with, however, occasional calm days, which become rather more numerous in June and July. August and September have mostly more quiet days than any other months. October has beautiful quiet days occasionally, with fine, soft illumination. By the first of November the foliage is pretty well gone. Then, in place of the soft lights and shadows of the woods, we get masses of parallel, gray trunks, which produce the very worst effects. A single tree, especially an oak tree, devoid of leaves, is a beautiful object, its branches give gracefully opposing lines, that support each other; but there is nothing of this sort in a wood.

When the wind blows steadily it is a mere waste of time and material to go out to photograph, however tempting the light may be; except, indeed, we go expecting only to make use of the late afternoon. On not very windy days we are almost sure to have an hour or two of calm before sunset.

Often the wind blows in puffs. In this case we closely watch the foliage and re-cap the lens the instant the first movement shows itself. With care, quickness, and gentleness, it is wonderful how much may be accomplished in this way. It should be

remembered, however, that if the puffs of wind between the quiet times are violent, it does not follow that the leaves, after this violent agitation, will settle down, each leaf to the exact previous position.

For the most part, however, it is a waste of time to attempt to photograph landscapes in windy weather. The evil effects of very slight winds may be materially diminished by observing one or two precautions.

When light branches are projected against a bright sky or clouds, the least motion of the leaves allows the bright light of the sky to pass in behind them. The result is that the leaves appear shrunk away and blurred,¹ an effect very often seen and most displeasing. If the sky is very dense, and prints perfectly white, such branches should always be painted out. A similar result follows when branches are projected against the reflection of the sky on water, or against any other bright object.

Again, where boughs with glossy foliage, well illuminated, stand out against deep shadow, and are moved by wind, they carry their bright reflection with them, and their image is extended, in place of being shrunk away as in the previous case. Each leaf, instead of being small and sharp cut, as we would wish to have it, is large, blurred, and undefined.

Therefore, if the air be somewhat in motion, the landscapist will do well to avoid foliage in either of these two positions, which are those that produce the worst effects. For when foliage standing before other foliage, and nearly equally illuminated, is moved, the result, though anything but pleasing, is not so very injurious as in the other cases.

On those priceless days, when the light is neither too strong nor too weak, and the foliage perfectly still, the photographer will do well to turn his attention especially to those landscapes in which the chief beauty lies in the foreground. Foliage should be introduced quite near to the camera, provided it can be kept in good focus together with more distant objects. Projecting boughs seen against the reflection of sky in water, so objectionable in the former case, may now be made to produce the most charming results, especially when accompanied by their reflected images.

¹ When no paper is placed behind the plate (or color on the back of dry plates), the same result may be expected by reflection from the back of the plate, quite independently of any movement of the leaves.

When it is intended to photograph immovable objects in a heavy gale, it is very desirable to find, if possible, some suitable support, such as a wall, a rock, or the stump of a tree, on which to place the camera, which is then steadied by placing on it a heavy stone. Perfect steadiness may in this way be obtained. In the absence of these resources, a cord may be fastened to the screw under the table of the tripod, and a heavy stone be tied to the other end, and let to hang down. Or it has been proposed to tie a loop in the cord, reaching just short of the ground, and to put the foot into the loop, and thus hold steady the camera.

It remains to say a word respecting the wind, in its relation to long and short exposures.

It has been said that the wind does not act more injuriously upon a long exposure than upon a short one, the effect having the same average in each case, in proportion to the exposure. This view is, I am persuaded, erroneous. The wind rarely blows steadily (such weather is to be particularly avoided), but generally in puffs. And these puffs are apt to come at intervals, such that, by watching, a short exposure can be caught between them, when a long one cannot possibly.

Indications of Weather.—As the photographer's success in outdoor work is always dependent upon the weather, all means of judging beforehand of what weather may be expected, acquire no small importance. These signs differ materially in different countries; thus the writer, after a careful observation of the indications furnished by the English Admiralty for the guidance of shipmasters, believes that, here at least, they are quite unreliable. The following are what, from long experience and personal observation, have appeared to him useful.

And, first, as to *wind*. The direction of the wind has much to do with its probable force. A westerly wind may be expected to blow moderately; a northwesterly wind strongly, and often violently; a north and northeast wind strongly; an east wind (if not inclining northwards) is in clear summer weather not often strong. But it is from southeasterly and southerly winds that the best photographic weather is apt to come, provided they do not bring rain. Often with them the air is perfectly calm. When the direction gets round to southwest, we have light breezes, often in puffs, a state of weather very favorable. Thus we are *most apt* to have good photographic opportunities with a southwesterly wind, but the

best weather we have comes with a southeast or southerly wind, though such a wind is less sure to bring it.

The clouds give many useful indications. Thus, if in the early morning we see the clouds moving rapidly, then, although the air below may be quite still, we are almost sure to have it rise in an hour or two, and blast the fairest expectations. Much may be inferred from the *forms* of clouds. *Feathery* clouds almost always bring wind; mottled, irregular clouds like flocks of sheep may or may not. The most favorable indication for calm air is when the clouds form in long, smooth, thin forms, imperceptibly blending into each other and into the sky; this appearance generally portends a still air and a soft light. Abrupt contrasts in clouds are more likely to bring wind.

The *previous condition of the weather* often affords a means of judging. The first day after a storm is apt to be windy, each succeeding day is more likely to be calm, and the calmest weather is apt to be that which comes immediately before the next storm.

The above indications relate to *stillness*. As to *clearness*, the following will be found useful:—

A *mackerel-back sky* indicates a change of weather. This name is given to collections of little clouds, three, four, or more times as long as they are wide, and arranged in parallel groups. This indication rarely fails to be followed by bad weather within twenty-four hours.

A *red sunset* generally precedes a fine day, a *gray sunset* a rainy, or, at least, an overcast day.

Although it is said that with the *sunrise* these indications hold but with opposite meanings, yet for such an opinion the writer has never been able to find any support, but has constantly seen good days and bad days follow both red and gray sunrises.

After two or three *white frosts*, rain may be expected. This fact, and also that when ditches or drains smell more than usually, rain follows, has long been familiar to all persons living in the country. On the other hand, all indications drawn from changes in the moon's quarters, position of the crescent moon, etc., in the sky, certainly amount to nothing.

Changes in the barometer have not the significance in this hemisphere which they have in the other, and little reliance can be placed on them.

Finally, it should be observed that although the foregoing indications as to stillness and as to clearness are *generally* reliable,

it cannot be affirmed that they are invariably so; they can be depended upon as showing the probable course of the weather, but not as being infallible.

Before terminating these observations on landscape photography, another remark needs to be made. In the very highest class of landscape prints there is sometimes seen a combination of great brilliancy and perfect softness, that surprises as well as charms, and leads directly to the question, how is this difficult combination of excellences obtained? Not by any secret process, that we know, for those who succeed best have always given their formulæ freely; it is, therefore, not the materials used, but the mode of using them, that is the essential point.

It is certain that—

Softness is promoted by length of exposure and rapidity of development.

Brilliancy is heightened by shortness of exposure and slowness of development.

The difficulty, of course, is that what promotes the one object interferes with the other, and this is why so few fully attain both. There is only one way in which it can be done, and this is to seek for softness by length of exposure, and then to combine this with brilliancy by a slow development.

In practice: Give a full exposure (using a fair dose of bromide), such that with an ordinary developer the picture would flash up instantly. So developed, the picture would be full of half-tone, but flat and tame. Therefore add water and acetic acid to the developer until, notwithstanding the full exposure, the image comes out gradually, avoiding, however, all exaggeration, both of exposure and development, and combining the two so that each shall correct the other's faults.

The best results, however, are always to be obtained by the use of a specimen of cotton that has had *exactly the salting that suits it*. To buy pyroxyline at random, even from the best makers, and then select a formula for salting at random, even if it be a formula of the highest authority, and then use a development recommended either in a treatise or by a friend, but having no definite relation to the cotton and salting, is to put the chances against a full success. In England few even of the oldest and most skilful landscape photographers make their own collodion; they buy ready made some particular sort which experience has

shown them to suit their particular way of working, often habitually and systematically mixing the collodion of two different makers in certain proportions. The collodion maker manufactures his own cotton, which he keeps as uniform in character as possible. Very long experience has taught him the very best salting for it, and he thus delivers a collodion of very high quality. The photographer thus gets a great advantage; in our system, where the photographer makes his own collodion, he for the most part gets an inferior article, even with the best cotton, unless by careful experiment (see p. 132) he finds out just what treatment some particular cotton requires, and manages it accordingly. This troublesome investigation he must either make for himself, or else pursue his work under telling disadvantages. The great excellence of English landscape work is partly due to this system of buying collodion instead of cotton, and partly to the character of the light in that country, generally soft and broken, with little of the burning brilliancy of ours.

The brightness of the print will also largely depend upon the albumenized paper. First-class prints will always need first-class paper: solid, full-bodied paper, well albumenized with sound, fresh albumen, and paper that has been carefully kept, and not too long.

§ 6.—Toning of Landscape Prints.

Although remarks on this point belong technically rather to the head of printing, yet they are so closely connected with the general subject of Landscape Photography, that I have preferred to give them a place here.

A landscape print is subject to none of the conventional rules of color that hold to a large extent with portraits, and even to some extent with architectural views. Every pleasing tone is appropriate—light brown, deep brown, warm brown, dark purple, purple black, steel gray, and pure black. All of these do well. Blue black is unpleasing, and is presumably never got intentionally, but results from accidental over-toning.

All the warm shades up to black do well, as has just been said, and a wide range of them gives a most agreeable diversification to a collection of views. It will be found, however, that *every negative has some particular tone that gives its best effects*. This is a fact that every photographer of refined artistic taste will perceive and feel: it becomes, therefore, in the highest degree desirable

to be able to say approximately of any negative in advance, or on seeing the first proof taken, what toning will best suit it. The following remarks may afford some clue to this knowledge.

Some negatives that have been taken with a highly favorable illumination, and have been developed exactly right, will exhibit so exquisite a combination of contrast and harmony of light and shade, that they will look well with any toning. They have no defects to soften, and can hardly be spoiled in the printing. For this higher class of negatives, a rich warm purple black, best obtained by the acetate of soda or by the benzoate toning bath, will be the most suitable.

Starting from a supposed perfect negative, we gradually pass down to less excellent effects. In all, we shall suppose that both the denser and thinner parts are full of detail (for if either lacks it the negative will not be worth printing), but that these parts, though each full of detail, do not work well together. If the printing be stopped when the thinner parts are right, the denser have not produced their best effects; if it be carried on until the latter are right, the former are too heavy and dark.

Now, this is a fault which may exist in every variety of degree. If it exists to a large degree, the negative is worthless; if only to a slight one, the intention here is to point out what course of action will render such a fault the least conspicuous.

The lighter and the warmer the color, the less this bad effect will be noticeable, a fact, I believe, which has never been pointed out before, though possibly some may have acted on it. A print *must* be exposed until the detail is out in the high lights, otherwise it is a complete failure. The effect, therefore, of the discordance here spoken of, is always to produce heavy black shadows, without detail, and the lighter and warmer the toning, the less offensive will be these dark masses, and the more of detail will be left in them. An observation of this rule will go far towards getting a fair print from a *somewhat* faulty negative. But it must be understood in the clearest way, that beyond a certain point the want of harmony is an irretrievable one.

Conversely, it is evident that if a negative lack contrast, either from the subject having been too monotonously lighted, or from an over-exposure, a pure black toning, without too much over-printing, will do what can be done towards affording a good result.

If these precautions be neglected, and if, for instance, a negative in which the contrast is already too great, be toned up to full black, the result will be that its faults, instead of being softened, will be aggravated. And if the photographer is unaware of, or does not appreciate, the principle here laid down, he may never obtain more than a passable result from a negative which, properly handled, might give a really good, though not a first-rate, print. Generally an acetate toning bath will be found the best for landscape prints.

CHAPTER VIII.

COMPOSITION.

§ 1.—Landscapes.

OF late years there has been a continually increasing realization of the defects and incompleteness of landscape photographs taken with entire ignorance of the principles of composition, and it is becoming well understood that mere technical skill cannot compensate for want of this knowledge, which, even in a very elementary form, is found to be invaluable. So that, if two persons, the one having some knowledge of artistic composition, and the other ignorant of it, undertake to photograph the same view, the former will always be enabled to make the best choice of the point at which to plant his tripod.

Cultivated taste has learned that the representation of a landscape gives a completely satisfying effect to the mind most easily by complying with certain general conditions which have been reduced to fixed rules. Too slavish a compliance with these leads directly to mannerism and sameness, but some acquaintance with them cannot but be of the highest use to every intelligent photographer.

Line of Direction—Balance.—In examining any picture, we may discern certain lines of direction. These lines may be of one prominent object, or may depend upon the directions of the principal portions of a succession of objects.

It is a rule that these lines of direction should *support each other*, as in Fig. 111, where the longer line is supported by the shorter.

The longer line may, for example, be that of a distant range of mountains, and the shorter that of a conspicuous bough of a tree, or of any other prominent object in the foreground; or both lines may depend partly upon distant and partly upon near objects—it is immaterial. The essential point is only that the characteristic lines of the picture shall balance each other. But

Fig. 111.

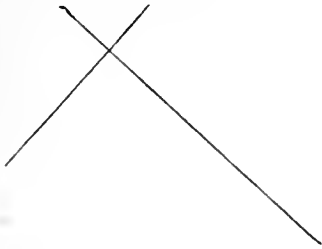
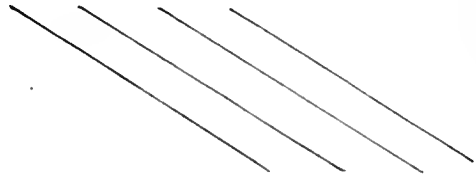

Fig. 112.



if the lines be all in one direction, as in Fig. 112, or even if not quite parallel, there is a want of balance, and the idea of weakness and of falling is given. Moreover, the effect of the repetition of direction is generally unpleasing, though it is occasionally used to convey the idea of receding distance. In any case, however, it is necessary that these lines should be balanced.

A succession of perpendicular (see Fig. 113) or of horizontal (Fig. 114) lines is, for the most part, unpleasing. As an example

Fig. 113.



Fig. 114.



of the former, we may take a row of straight-stemmed trees, the effect of which is infinitely less pleasing than if their directions are diversified. Parallel horizontal lines are rarely allowable; sometimes, however, they are employed by artists in "parallel perspective"—that is, where buildings are represented in full front view.

As pictures are commonly bounded by four right lines, any arrangement of the important objects in a picture that brings them side by side, and at equal distances from the base line, produces to some extent the parallelism of Fig. 114. Similarly, if

they are directly over one another, they form parallels with the side, as in Fig. 113. The same principle applies also to the introduction of a tree with a straight, perpendicular shaft, near to the edge of a picture. It falls into an objectionable parallelism with the side line. These faults are to be borne in mind and avoided.

The Diagonal Line.—According to the direction into which the principal lines of the picture fall, the composition is distinguished

Fig. 115.

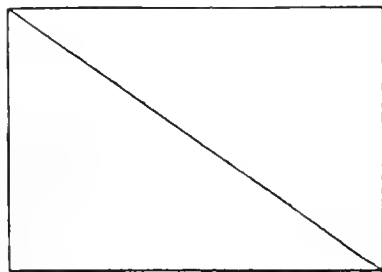

into angular and circular. The diagonal line, the simplest form of angular composition, is exceedingly well adapted for representation of perspective, especially when, to get a better range of effect, the distance is placed towards one side of the picture.

It is by no means necessary that the principal line of direction should proceed directly from one angle to the other. This angular line of direction should always be *supported*—that is, the eye carried along it should not be dropped vaguely, but fall upon some object, which, though it must be distinct, need not be large. This object is termed the "*ruling point.*" An inspection of landscapes and groups executed by artists will show how far ingenuity has often been taxed to hit upon some object of this sort in which to terminate a line of principal direction. In country scenes, a dog, or a fowl, or any other small object in keeping with the general subject, will be introduced into the foreground. A little examination will show that its exact position has been determined by a line of principal direction, and that the object has been placed at its exact intersection with the ground. The universality of this practice seems to indicate that it is correct; the principle is evidently that, after the eye has been carried from one to another of the striking features of a picture, it should not finally fall blankly upon nothing, but that there must be some sufficient object upon which to rest. In most cases the resting point or ruling point is made dark on a lighter ground, though in some cases a lighter object than those that surround it is used.

A beautiful and familiar instance of the balance of opposing lines of direction is seen in mountains, the opposite sides of which

rest against each other thus: Λ . So a gap between two mountains gives lines that balance each other in the form V .

Circular Composition.—Curved lines of direction are often introduced with very fine effect. Views of lakes, or of curved reaches of rivers, will be apt to fall into this form, and it is seen in many other compositions of rural scenery.

The Foreground.

The foreground is the portion generally most under the photographer's control, and those who desire to obtain the greatest success will spare no pains in the selection of this part of their picture.

The foreground should be diversified. A level, unbroken foreground of grass or meadow cannot be expected to give a good effect. It weakens the effect of the distance, and deprives the picture of much of the character that it ought to possess.

A portion of the foreground should be occupied by some dark object, whose effect will be materially enhanced if brought into immediate contrast with some of the highest lights of the picture. The best effect is for the most part attained by placing the dark object in the foreground under the farthest distance. This gives great tenderness and softness to the distance, causes it to recede from the foreground, and at the same time supports it by lending firmness and foundation to it. Too much attention to this point cannot be given by the landscapist, who will, however, often have his patience and ingenuity taxed to the uttermost to find anything like a satisfactory foreground to his pictures.

There is a great beauty in very trifling objects, which many habitually overlook. Bushes and vines, rocks, stones, logs, often have elements of attraction that reveal themselves only by observation and cultivation. A tasteful arrangement of such objects in the foreground of a photograph lends to it an inexpressible charm.

The writer cannot, perhaps, find a more striking illustration than in a clump of brambles. To many, such a thing would seem to be so essentially ugly that it should be excluded, is possible, whereas, on the contrary, it is, both in nature and in representations of scenery, almost always a very beautiful object. The stems present often a beautiful combination of right lines and graceful curves, the leaves have a surface that sends back light

— enough to give brightness to the lights, and, by contrast, depth to the shadows. Often the more succulent shoots will hang over in festoons of singular gracefulness. Late in the autumn, banks of brambles retain their leaves long after the trees are stripped, and then, if they can be introduced into a picture, they are most valuable.

When the foreground is so level and unbroken that no diversification can be introduced, a *shadow*, as of a large tree, falling across it, at once relieves the tameness, and produces a beautiful effect.

The Distance.

The distance should never find its place exactly in the middle of the picture, which by such a disposition becomes divided, as it were, into two equal halves, to the complete destruction of its artistic character. In fact, no important object should be placed exactly at the centre of the picture, which is by artists considered to be a "weak point." Nor should any important object be placed exactly upon the middle line which divides a picture from top to bottom or from side to side. Its effect will be always better if it is distinctly removed from either of these lines.

A peculiar pleasure is given when the eye is conducted from the foreground to the distance by lines of direction. These lines may be one or both banks of a river or stream, a picturesque road, or other object. The leading should be rather by broken and diversified lines than by straight ones.

A certain pleasure is communicated when objects in the middle distance are repeated in the farther distance. Such a repetition is not to be by the same object, but rather by some other object in strict keeping. This rule is closely allied to one in painting. It is laid down in painting, that if a particular color be introduced in one place only, it has the effect of a spot or blot; the color must be carried through the picture, or at least part of it, by recurring here and there. As in colors, so in objects. If trees are seen in the foreground or middle distance, the eye is gratified by seeing them reappear in the distance. If a cottage or other building be a conspicuous object in the foreground, the eye likes to see something similar in the distance.

The effect of a high light in the extreme distance is greatly enhanced by placing a dark object in the foreground, somewhat under it, but not perpendicularly. This acts partly by throwing

the distance farther back, and thus powerfully aiding the impression of distance, and partly because the light becomes lighter and the darkness darker through contrast.

If the different planes of distance are not well made out in a photograph, that is, if they do not appear to occupy the same relative position in the photograph which belongs to them in nature, the fault may arise from the use of too small a stop, which tends to produce a sort of map-like effect, or from the use of a lens of too short or too long a focus. In the first case the middle distance is transferred to the extreme distance, and confounded with it. In the latter case the middle distance is forced forward into the foreground. (See chapter on Perspective.)

The Skies.

A blank white sky always disfigures a photograph, and must be avoided if possible. Several alternatives present themselves, one or other of which should be adopted whenever possible.

If large slow-moving clouds are present, they may sometimes be caught, especially if the illumination of the landscape be good, and so that it comes out rapidly, and without a prolonged development, which, in wet plates, always thickens up the skies. Large stops are always favorable for getting clouds with.

If clouds cannot be taken with the landscape, they may be taken separately and *printed in*, for which directions are given elsewhere.

But it is an excellent plan to cover as much as possible the sky with foliage or other objects. Large trees in the foreground will aid in this. In hilly countries the elevations will be a great aid. In level districts it will often be useful to *raise the horizon line*. Fortunately this line is, in landscapes, very much under control. In architectural subjects, as the camera must always be horizontal, we can only effect this by raising the camera front, or bringing in the use of the swing-back. But in landscapes with no buildings a good deal of tilting may be done without evil effects. The horizon line is thus raised, and the proportion of sky diminished.

In *dry plate work* we may often keep the sky thin, and thus avoid the unpleasant whiteness. This is a very great advantage, and is especially to be obtained with collodio-bromide plates, a most important feature of that process.

Some experienced landscape photographers, who know the value of even a little shading to the sky, adopt regularly the following plan: When the printing is done, they open one-half the back, and bend the sky end of the print in a curve backwards, and so hold it to the light; it thus becomes somewhat darkened, and by doing this skilfully, the shading is regular. The amount of trouble is almost nothing, and the gain decided. The writer believes, from an inspection of prints by Bedford, Sowler, and other masters of the art, that they constantly avail themselves of this method.

Position.

The whole picture is generally composed with reference to some one important object, to which all the rest stand in some more or less definite relation.

Care must be taken that this object (or indeed any object to which it is intended to give prominence) shall not occupy the centre of the picture, which is always the weakest point in the whole. Such an object may be thrown to the right or the left, above or below; it is unimportant, provided it be kept out of the centre. If the conspicuous object improperly placed there be small, it will look like a spot or blot; if long, as, for example, a tree, it will divide the picture into equal right and left halves.

It is apt to be a blemish if an object be represented as partly in the picture, and cut off by its edges: it is true that to some extent this is unavoidable, but it is objectionable, especially when the subject so cut off is important.

Thus, if in a landscape a river is seen to run into one side, and out of the other, a peculiarly unsatisfying impression is left upon the eye, which is removed if the ends of the river are concealed by trees in the foreground, rising ground, buildings, etc. *Trees* themselves are often unavoidably cut off by the sides and top of the view. This is supported by the eye; but if a building of at all a conspicuous character appears in the picture, and is partly cut off by the edge, the effect is most unpleasing. With the human figure this is still worse.

It has been held by some that no figure should be introduced with the eyes directed at objects not themselves included in the picture, and it cannot be doubted that the unity of effect is broken by the spectator's attention being thus drawn away from the objects represented.

It is still worse when the figures are represented looking at the camera itself. This is the commonest of mistakes. At the moment of taking the picture the camera is of course the central point of interest to all present, and, unless expressly cautioned by the photographer, any person who is in sight will inevitably be found to rest his eyes on that instrument. In a great many cases the figure will give a better effect if the back or side is turned to the camera. Let us suppose that we are looking over the brow of a hill, upon a lake or river below. A figure in the foreground, resting against a tree, and apparently contemplating the scene, will have an infinitely better effect than one apparently watching those operations which it is the special object of the photographer to avoid recalling. In the one case the figure draws attention *to*, in the other *from*, the subject of the picture.

The figure itself should be thoroughly in keeping with the scene. Just as a neat trim villa is a particularly uninteresting subject for a picture, so a carefully dressed person looks completely out of place in any rural scene that is worth planting the camera before. A laborer, a pedestrian carelessly dressed, country children, these are figures in keeping with the subject. If a river or a lake form part of the picture, a man fishing or wading will add to the life of the scene, but his appearance must correspond with surrounding objects.

Generally speaking, whatever is neat, trim, and elegant, is displeasing in any view of natural scenery. A handsome carriage introduced into the picture will look absurd—a farmer's cart will probably be in place and a great help. It is not so much the object itself, as its condition. A new market wagon, for instance, with a glazed top, would spoil any picture. An elegantly shaped and prettily painted skiff may look absurd, an old barge or canal-boat will be appropriate and pleasing. A gentleman in a dress coat, with a cane, a lady with flowers and a parasol, introduced into any country scene, will spoil all our satisfaction in observing it, whilst appropriate figures will be always useful; the rule that such figures must not look towards the camera is never to be forgotten.

Nor should the figures be placed in too close juxtaposition with the objects of principal interest, from the effectiveness of which they would tend to detract, whereas in weak points of the picture they will prove a positive benefit. They should always assume easy attitudes, and such as will not be ungraceful or ridi-

culous. The writer has seen an otherwise very pretty photograph, in which was a male figure reclining on the ground. As the face was towards the camera, the body was foreshortened, and the one conspicuous object about him was the soles of his boots, which exactly faced the spectator, and which, by reason of the violent perspective of a short-focus lens, appeared greatly increased in proportionate size. Such errors need only to be understood to be shunned.

The Horizon.

It is always in the power of the photographer to place the horizon where he will. If there be no subjects presenting perpendicular lines, the camera may be tilted at will; if there be, the sliding front may be raised or lowered, or inclination of the lines resulting from tilting may be cured by the use of the swing-back.

Raising the horizon line will often increase the beauty of the picture, but, it must be confessed, somewhat at the expense of truth. If a perfectly *correct* delineation of any scene be desired, the camera must be levelled. Raising or depressing the camera, entirely alters the relative inclinations of natural objects. Thus, if a road descends a hill, it will equally descend in the picture if the camera be levelled, but the writer has seen such a road represented in a negative as perfectly level, the whole descending effect having been obliterated by inclining the camera downwards. This raises the horizon line, and with it all the objects beyond the foreground.

Where the object of the photograph is simply to produce a beautiful picture, it is perfectly allowable to modify and improve the scene in any way that we can. But where a truthful representation is desired, the greatest care will be needed. There exists a mistaken idea that photographs, being taken by mechanical means, are necessarily correct representations of natural objects, and they are consequently offered and received as absolute proof in courts of law, whereas nothing is easier than to create false impressions with the aid of photography. No delineation of natural objects is correct unless made with a lens of not less than ten nor more than twenty inches in focal length, with a *levelled camera*, and with a centrally stopped lens. And before any photograph is received in evidence, the photographer ought to be required to testify as to these points; at least this is true when the

question depends upon *relative size* or *position*. Of course, if the question is simply as to the existence or non-existence of some particular object, the objections here stated do not exist.

It is an axiom with artists that the horizon lines should never come across the middle of the picture and divide it into two equal halves, but always above or below it. From what has been already said it will be evident that in photographs the horizon line will be more frequently above than below the middle.

Contrast.

Some of the highest pleasures which the eye is capable of enjoying depend upon contrast. Contrast is of various kinds. Of *light*, where the artist throws his deepest darkness against his highest light, thus strengthening both. Of *size*, as, for example, where the greatness of the majestic oak is made more apparent by the shrubs or bushes at its base. Of *form*, as where the grand elevation of the mountain is further ennobled by the level lake or plain at its foot. Of *character*, as when the graceful lines of pine-trees are contrasted with rugged roughness, as in Alpine hills, or where slight and tender vines, with delicate tracery, are seen clinging to strong trees or to the rocky sides of hills, or are contrasted with the rigid lines of architecture. Of *season*, as when winter snows look down from the mountain upon summer verdure in the valleys beneath. Of *mass*, as when light clouds, the lightest of all visible objects, rest upon mountains, which, of all natural objects, give the most striking effect of weight. In a word, the beauty of contrast is that which most completely pervades all nature. All our ideas are formed by comparison, and contrast is comparison in its most vigorous form.

The brightest objects in a picture should not be too far from the centre. If placed close to an edge, the effect is very objectionable. The tendency of a picture should be to converge attention to the centre, not to scatter it towards the edges.

Repetition.

The repetition of lines of direction, as has been already said, is for the most part unpleasing, and this holds with both groups and landscapes.

But the repetition of objects themselves is often very pleasing. The echoing of a near object by a distant one has been already

spoken of, but perhaps the greatest beauty of repetition is where we see objects mirrored in calm water. Few persons are so utterly destitute of the sense of the beautiful as not to appreciate, however imperfectly, the charm of this exquisite reflection. The commonest object may in this way be rendered beautiful and attractive. A log, a branch, a boat, insignificant in themselves, immediately acquire a charm by being repeated in the water. Often the inversion that accompanies reflection materially adds to the charm by the variety which it affords, or by forming, as a reflection often does when looked on in connection with the object itself, a charming symmetrical figure.

Atmospheric Effect.

When a scene in nature, embracing objects at various distances from the spectator, is depicted upon a flat surface, we are enabled to distinguish between objects near and distant, in two different ways.

One of these is *Linear Perspective*, treated of elsewhere. By virtue of it, distant objects are diminished in size and brought closer together, thus giving to the eye the information that they are proportionately remote.

But the effect of linear perspective is greatly enhanced by another agency, to which the name of aerial perspective, or, better, atmospheric effect, has been given.

The atmosphere in its usual conditions is not wholly transparent, but interposes an exceedingly delicate veil, imperceptible indeed as respects neighboring objects, but becoming more evidently distinguishable as the distance increases. The eye is thus greatly aided in judging distances, which it unconsciously computes by the extent to which the softening effect of the atmosphere reaches.

If this softening effect of the atmosphere be studied, it will be found to act as follows:—

1. *It diminishes contrasts.* Dark shadows lose something of their darkness, high lights of their brightness. This opposite effect of the atmosphere on light and on shade needs some explanation. Lights lose part of their brightness by reason of the slight opacity of the atmosphere through which they pass. But the darkness of the shadows is lessened by the light which falls, not on them, but *on the atmosphere through which they are viewed.*

We have a familiar example of this in the sky itself, which is only the deep shadow of the outer darkness of space viewed through a not perfectly transparent medium, which medium is itself lighted up by the sun, and, under a well-known physical law, diffuses the more refrangible or violet rays, and transmits the rays belonging to the less refrangible end of the spectrum. In clear weather the sky is deepest in color, because there is less opacity in the atmosphere to receive and reflect the sun's light. On a high mountain the sky is darker still, and at very great elevations appears almost black.

2. *It obliterates details.* Smaller objects and parts of objects easily distinguishable when near by, cease to be so in proportion to the distance to which the object is removed, and of this the eye takes due note and recognizes the cause.

3. *It softens outlines.* The dead limb of a tree near by, for example, cuts boldly and sharply on the sky, but the outline of a trunk upon a hill in the middle distance is already somewhat softened, and the outlines of distant mountains are still more so.

Consequently, atmospheric effect tends to give soft grays and middle tints to distant objects, and to efface all sharp contrasts of light and darkness. Lines also cut each other less sharply. In nature we find a very wide range of variety as to this influence. When the air is very free from moisture, as on some of the arid plains at the base of the Rocky Mountains, atmospheric effect almost disappears, and distant objects appear unnaturally and deceptively near. It is not too much to say that the capacity of the eye for judging correctly of distances is actually destroyed. From this extreme we may pass through every degree to the other, when the air is so laden with mist that near objects seem farther, and distant objects disappear altogether.

It is a curious fact, and one of the highest importance for the photographer to understand, that both the process which he uses and his lenses themselves may have a great influence on the amount of atmospheric influence which will appear in his pictures.

The tendency of the ordinary wet process is to give a moderate amount of atmospheric effect. The dry processes differ extremely in this respect, according to the preservative used. Thus tannin, cloves, coffee, gallie acid, and similar preservatives tend to diminish atmospheric effect, whilst gum has the very valuable property of enhancing it in quite a remarkable way, and

thus becomes a most valuable adjunct to other preservatives, though, when well managed, it is capable of acting well alone.

The lens has likewise something to do with this rendering, though its action has been by some writers a good deal exaggerated; it is the *size of the diaphragm* used that has more to do with the atmospheric effect than the lens itself.

A large diaphragm will always tend to *increase*, a small one to *diminish*, aerial perspective. This is caused in two distinct ways, co-operating to the same result. For a small diaphragm will always greatly increase the depth of focus, so that when the focus has been taken, as it always must be, on near objects, a small diaphragm will cause the distance to be in sharp focus also. This will increase the detail of the distance, and, as it has been already shown that one way in which atmospheric effect shows itself is in tending to obliterate detail, the greater depth of focus necessarily tends to counteract the effect of the atmosphere. Again, a small diaphragm always tends to harshness of contrast, and it has been also shown that aerial perspective especially shows itself by diminishing contrast. Clearly, therefore, aerial perspective will be produced in direct proportion to the size of the diaphragm. This explanation tends to throw additional light upon the fact stated in a previous chapter, that a large stop materially aids the effect of distance by placing objects in their proper planes of distance from the eye.

It is, however, sufficiently apparent, from what has been previously said, that lenses will differ somewhat amongst themselves, independently of the diaphragm, as to the rendering of atmospheric effect, inasmuch as some have greater depth of focus than others.

Those photographers who are accustomed to plant their cameras in front of any conspicuous object, satisfied if it covers enough of their plate, and if they can get a clean negative of it, will naturally, in the same spirit, endeavor to get the same sharpness in the distance (so far as practicable) as in the foreground. Such will be found working with small diaphragms, and acid baths, and getting technically perfect negatives, which will yield prints that no one cares to look at a second time, prints in which the foreground lies flat upon the middle distance, and both on the extreme distance, which, instead of striking the eye at once with a unity of effect, have to be looked at attentively before the rela-

tions of the different parts explain themselves—in a word, prints which are a reproach to photography.

It must at the same time be very clearly understood that the writer is as far as possible from wishing to say that a photographic landscape should show a clean cut foreground, and a hazy, woolly-looking distance. No rules must be carried to excess, or the truth and beauty that result from them are destroyed by exaggeration. That objects several miles away should be as distinct and sharply cut as those near at hand, is unnatural, or at least occurs in certain regions and in peculiar states of the atmosphere only, with which we have not here to do. It cannot be right, therefore, and it certainly is not pleasing to an educated eye, that they should be so represented in a photograph or in any other form of delineation. As already said, the landscape painter, with this matter under his absolute control, always softens the distance.

§ 2.—**Portraiture.**

What has been said in the foregoing section finds its natural application also to portraiture. Lines must be balanced and supported; light must be brought out by opposing it to shade, in portraiture as in landscape work.

To give an agreeable and graceful effect to a single standing male figure, has always been a difficulty which has taxed the genius of artists to evade. When a man clothed in our modern habiliments stands erect, the lines of his arms and legs fall into parallelism with his body, and the objectionable effect of parallel perpendicular lines has been already pointed out (Fig. 113). There is perhaps no effectual way by which, in our ordinary portrait, this difficulty can be disposed of, unless some characteristic occupation or position can be adopted. A soldier, for example, may rest upon his musket, a fisherman may have his rod so disposed as to afford a supporting line, and so on; but as the great mass of those who present themselves to be represented by the camera do not care to figure in connection with any particular vocation, it follows that for the most part the best that can be done is to adopt a sitting posture, not in profile unless the back legs of the chair can be supported, and try to relieve this by surrounding objects. Good effects are often obtained by representing the sitter as either engaged in some occupation, reading, playing on some instru-

ment, examining some object, or, often better, as having just turned from having so done.

When several male figures are introduced together, their lines may be made to support each other; but here, again, a photographic difficulty is introduced—the necessity of keeping the heads to a certain extent in the same plane of distance.

The ingenuity of the photographer will often be here taxed to a severe extent. He may be aided by the following observations:—

Where two or three heads are present, they should rarely be placed, as so very often seen, on the same level, but should form a pyramidal arrangement, or else fall into the diagonal line. Or the middle head may be the lowest. If a fourth head be introduced, it may either fall into one of the lines of the above forms, or the lozenge-shaped composition may be adopted. If more than these are present, they may either have a place in the principal arrangement, or a secondary group may be formed. It is always to be remembered that, in obedience to the exactions of the lens, the farthest figure must be also the most central.

A group of three persons will generally be the most manageable. Somewhat less so with two or four. When the number increases, difficulties are multiplied; when it diminishes to one, the difficulties of getting a satisfactory attitude are, as already said, most serious. A standing portrait of a man gives almost invariably the effect of a person placed for the express purpose of having his picture taken, and this is apt to be made worse by the conscious look generally assumed by the person.

The same remarks apply, though to a somewhat less extent, to female portraits. The form of the dress considerably relieves the difficulty, as it represents two opposing inclined lines which tend to support each other. Nevertheless, single portraits of standing female figures are apt to bear a stiff appearance, unless in the hands of very artistic photographers. When sitting, however, this is wholly changed. The drapery can be very much varied, and a great support can be got by regulating the folds of the dress so that these shall run in directions which shall relieve and support the other lines of the picture—that is, that some of the lines of drapery shall oppose and support the lines produced by the direction of the body, the position of the arms, &c. The position of the arms can often be regulated in sitting figures, both of men and women, to greatly aid in balancing the lines of

the body ; and here a thousand expedients come in to give occupation to the arms and explain their position.

In groups of female figures, or of men and women together, the same remarks as those made respecting the positions of the heads for men of course apply.

Two useful observations remain to be made before we close this very brief section on an important subject.

The lines which connect the heads of a group, form always the principal lines of the picture. Such lines should never be permitted to simply run out and end in nothing, but when carried by the eye to the bottom of the picture, should fall on some object, precisely as already explained in landscape composition. Thus, if a line of direction, when extended by the eye, reaches a table, for example, at the point of intersection there should be placed some small but very distinct object, dark on a light ground, or light on a dark ground. A book, an open letter, or, still better, some object characteristic of the taste or occupations of one or more of the sitters, will be suitable. If a line of direction reach the floor or a wall, the same principle of course holds good.

Again, a line in some parts of the picture, whose direction crosses that of the main line of the picture, will give an excellent effect by supporting it. This line may be anything, a cane or staff, any object whatever, even the line of an arm. It need not cross the line of direction, only so that its direction does so.

Thus, let A, B, C , be the heads of any group. $A B$ will be the most important line, opposed and balanced by $A C$. But, also,

Fig. 116.

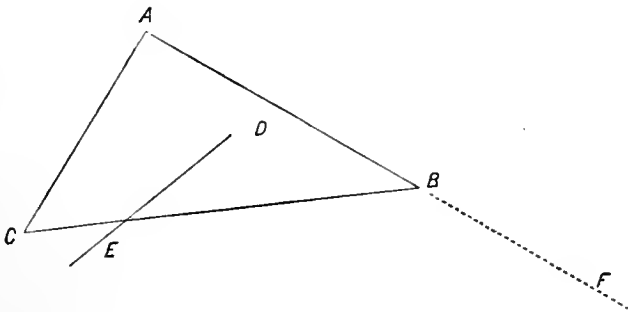

some other line, $D E$, if introduced, will greatly support the line $A B$ and balance the picture. And where the line $A B$, if continued, would terminate at F , on the ground or elsewhere, there should be some object for it to rest upon, as explained above.

§ 3.—Influence of Light.¹

Our perception of the inequalities of surface, of relative distance, and in fact of the shape and position of bodies generally, depends almost wholly upon light and shadow.

Take, for example, an outline drawing of a building. The eye, chiefly by habit and education, understands that a solid body, and not a flat surface, is intended to be depicted. I say, the eye *understands*, for it seems more like a deduction than a perception.

If now the artist washes in even only a single shade of neutral gray behind each projection, how these projections suddenly start out and strike the eye! As if by magic, the whole building has assumed a visible solidity, and if the work has been correctly performed and the shades duly graduated, the eye instantly recognizes the length, breadth, and height of the edifice, and is able to derive whatever pleasure its justness of form is fitted to afford.

Any photographer who frequently passes a public building with many projections, such as are especially to be found in Gothic architecture, and who will stop and carefully study the effects of different lights upon it, will be amply repaid, and will learn more by a few minutes given twenty or thirty times, or still oftener, than by a year's random photographing.

At times the light is so exceedingly uniform and so broken by clouds, that every portion of a building will be almost equally lighted. So far from this being an advantage, the structure will be found on critical examination to look extremely flat and tame, and if photographed in such a light, its photograph will also be deficient in relief. This great uniformity of light may occur with various amounts of illumination, and though more common in dark weather, will sometimes be seen when the light is tolerably good.

When the clouds are thinner, a considerable quantity of direct light (without notable sunshine) may pass through them. In this case projections cast faint shadows, and the relief is greatly improved.

With still thinner clouds, *faint sunshine* passes through. The inestimable value of a very faint sunshine every experienced photographer will fully recognize. Photographs of natural scenery,

¹ See also *ante*, Remarks on causes of unsatisfactory results in portraiture.

taken in the absence of sunlight, are apt to be tame and monotonous. A faint sunlight gives an exquisite relief and life to the whole, with beautifully illuminated shadows.

When the sun is fully out, and especially towards the middle of the day, the contrasts become excessive, and before the details in the shadows impress themselves, the high lights suffer.

The case of a building has been chosen as an example, but precisely the same holds good with portraiture. The shape of features, the character and expression of the face, all these depend upon light and shade and their due management.

In examining the work of professed portraitists, we constantly observe the faults here pointed out as being so easily seen and judged in a building, which last, from its invariable position and (so to speak) expression, enables us to compare the effects of different lights so very advantageously. These faults lie, on the one side, in too uniform a lighting, by which the features are rendered flat and the expression stupid, or at least less intelligent than the original; and, on the other, in too great contrast of lighting, whereby the character of the features is exaggerated, and the expression rendered stern and hard.

These two generic faults represent the Scylla and Charybdis of the portraitist, and, with the varying lights of the day, will require his most intelligent efforts to avoid.

CHAPTER IX.

ON COPYING.

COPYING by photography falls into three classes:—

1. Copying oil paintings and drawings in color.
2. Copying mezzotints and lithographs, and drawings in Indian ink and sepia, &c.
3. Copying line engravings, wood-cuts, pen and ink drawings, and pencil drawings.

These three classes will require different treatment, but all the varieties in one and the same class will require the same, or nearly the same, management.

Old oil paintings, in which the backgrounds have become very

dark and the colors have lost their brilliancy, are especially difficult to copy; in fact, in many cases, it will be impossible to obtain really satisfactory results.

The best instructions that can be given are, to use a pretty wide stop, give a long exposure, and use a collodion containing equal parts of bromides and iodides. (See also Chapter XV., Remarks on keeping plates.)

In the second class above enumerated, we included subjects which, though in monochrome, present *gradation of tint*. These will require to be treated, through all the stages, very much as views, and with the same care to avoid harshness and excess of contrast.

On the contrary, the third class will require a widely different treatment. With these the object will be to get, not to avoid, strong contrasts. The originals are composed of only white and black, the half-tints depending upon the presence of more or less of each of these constituents. A white and black negative will therefore be wanted.

But it is an entire mistake to suppose, as was for a long time believed, that this was best accomplished by the use of a collodion containing little or no bromide. The author of this book long since pointed out that copying was best done with ordinary landscape collodion. Iodide of silver is more sensitive to a strong light, bromide to a weak light. Now, as line engravings require to be copied with a very small stop, the light is always weak, consequently bromide is needed; and this view is fully supported both by direct experiment and by common experience.

To obtain a fine copy of a line engraving, in which the hair-lines are to be faithfully and sharply reproduced, requires a good lens, well managed. The stop must be very small, not exceeding f 60, or one-sixtieth of the focal length. The lens should be a large one.

Copying is the most delicate and difficult branch of photography. The faint light admitted by the small stop cannot form a brilliant image; the attraction to the developer is therefore weaker, and the tendency to the production of stains is greater, whilst no department of photography requires so absolute an absence of stains as this. Consequently, photographers generally confine themselves to the central parts of the plate, or at least leave a border of an inch or more around the image, as it is the borders that are most exposed to these troubles.

The bath must necessarily be in good order, giving clean, blooming negatives. The developer must have a full, though not excessive, dose of acetic acid. The development must not be prolonged, but be rather a brief one, and if a very strong negative be wanted, recourse must be had to after-intensification.

The best means of effecting this is to place the plate in a solution of corrosive sublimate until it becomes entirely white, and then to flow it with a 1-grain solution of cyanide of potassium. The cyanide instantly blackens the negative, whilst at the same time it clears away all tendency to veiling, if any existed.

Another excellent method is to chlorize the paper, and then to apply Schlippe's salt. (For details of both methods see p. 173.)

But, for the most part, an ordinary development, followed if necessary by a re-development, after fixing, will be sufficient, remembering, however, that neither development nor re-development should be pushed. The re-developing liquid should be used no longer than it is quite colorless, instead of serving, as in other work, as long as it is clear. Heavy deposits of silver, if allowed, will evidently clog up the finer lines.

The lens to be used must be free from distortion, and have as flat a field as possible. The old orthoscopic lens, now rarely made, copied excellently. The view lens is unsuitable. Almost any centrally stopped lens, except the portrait combination, may be used with success, the Zentmayer, Steinheil aplanatic, Dall-

Fig. 117.

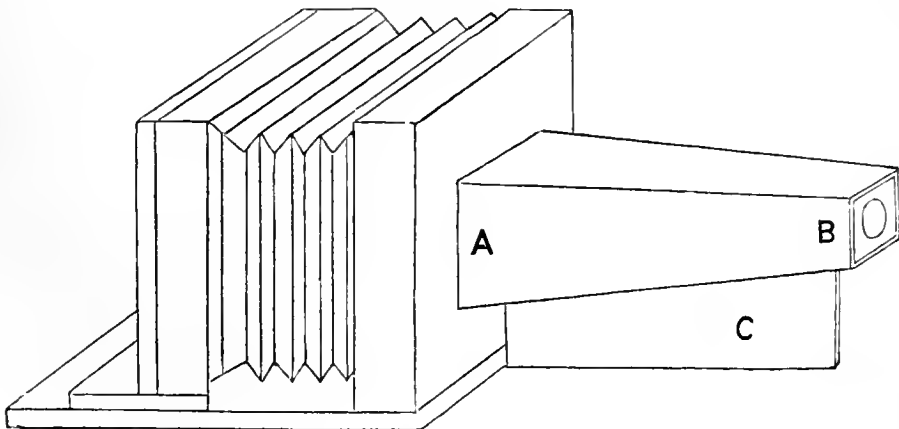

meyer rapid rectilinear, Ross's doublet, the triplet, from any of these, if a good specimen of its class, good work may be expected.

As the focus is always longer in proportion as the size of the

image is large compared with the object, it follows that for copying, the camera will often need to be lengthened out, and this is done with an "extending cone." Fig. 117 represents a form devised by the writer, in which the flap C is hinged on to the cone, and serves to support and steady it. The cone at B extends beyond the tube of the lens, so as to form a sort of hood, excluding extraneous light. Unless means are taken to prevent extraneous light from falling on the lens, brilliant and clear copies cannot be obtained.

Generally speaking, it is best to place a line engraving in full sunshine, which should fall on it in a direct line, and not obliquely. The more slanting the direction of the sun's rays, the more conspicuously will the grain of the paper, and also other irregularities, be rendered in the negative. By using direct sunshine, it becomes possible to work with the smallest stop furnished with lens, thereby reducing the *astigmatism* (p. 61) to a minimum, and so to obtain the hairlines in the high lights of the engraving, accurately reproduced.

For copying *Daguerreotypes*, sunlight reflected by a mirror gives excellent results. *Photographs* may be copied in the same way, or by a good strong out-door diffuse light. They do not need so very small a stop as line engravings do, and consequently not so brilliant a light.

Mechanical Appliances.—When an old picture is to be copied, it will be well cleaned and then hung up in the sunshine. (It seems probable that an application of *glycerine* would give a clearness and brightness that would materially aid in copying. Afterwards the glycerine could be easily removed with a wet sponge.) Fix the camera so that each corner of the picture shall be equally distant from the centre of the front lens, and take care that all parts of the picture shall be equally illuminated, also that the direction of the sunlight shall be such that no reflections shall reach the lens.

The copying of engravings and smaller pictures may be done in the same way. But it is more convenient to make a special arrangement as follows:—

A square piece of wood of convenient size is placed upright upon a long narrow table, giving the piece of wood the same breadth as the table. At the sides of the board (see Fig. 118) strips two or three inches wide are fastened, coming some inches

below the table top, and fitting close up to it. These act as guides, so that when the square piece of wood is pushed backwards or

Fig. 118.

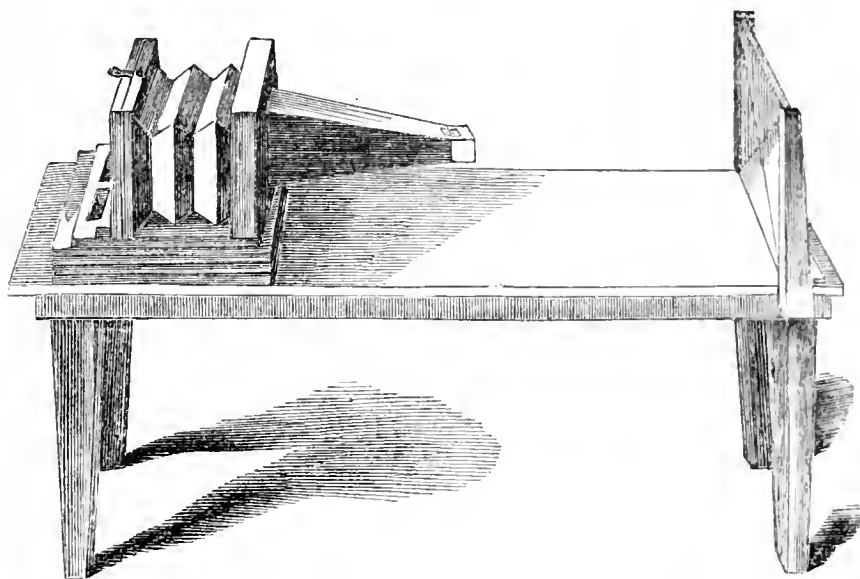

forwards, it always retains a position at right angles to the long side of the table. Behind another narrow strip is fastened, to act as a base and keep the board vertical. Diagonal lines are drawn from the corners, fixing the centre. The camera is raised on blocks until the middle of the lens is opposite the intersection of the diagonals.

If now we place any object to be copied on the centre of the board, which the diagonals easily enable us to do, we have simply to move the board backwards and forwards until the size and the focus are obtained. The general arrangement secures what is always essential in copying, viz., *that the object to be copied shall be exactly parallel with the focussing screen*. In the arrangement here described, the camera is always kept with its sides exactly parallel to the table, then the board being at right angles with the side of the table, the necessary parallelism is insured.

Plans may be well copied by simply laying them on sensitized paper and exposing. This gives a paper negative, which is to be laid on other sensitized paper and exposed—if the resulting positive is not strong enough, it is brought up by development. Plans of several feet square, made for the Treasury Department at Washington, are thus beautifully multiplied by Mr. Walker, the photographer of the department.

CHAPTER X.

THE STEREOSCOPE.

THIS ingenious invention of Prof. Wheatstone depends upon the fact that the two eyes see the same objects differently in consequence of their difference of position. If we view a collection of objects, as, for instance, trees in a grove, and then moving our position by a few yards, we view them again, their relative positions will seem changed. A smaller change produces this in a lesser degree, and even the space between the eyes corresponds to a change of aspect, which, small as it is, aids greatly in fixing relative positions. This will be better exemplified as follows:—

Let the polygonal figure (Fig. 119) be viewed by the eyes E and E'. Its distance from them and its size may easily be imagined such that the eye E will see the five sides, 1, 2, 3, 4, 5; whilst E' will see the five sides, 2, 3, 4, 5, 6. The eye has, by long experience, learned unconsciously to combine these two portions of the polygon, and to understand thereby that it is a solid body, and not a mere projection on a flat plane.

Fig. 119.

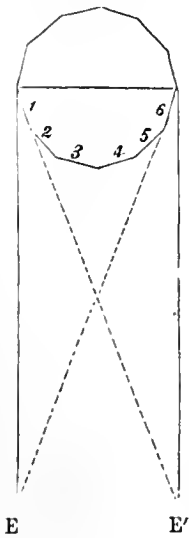

If we suppose, instead of the polygon at Fig. 119, that we look at a pillar, of a portion of which that polygon is a section, the mind realizes that it is a solid body by its consciousness that the one eye sees partly round it on the one side, and the other upon the other side.

If then, whilst viewing any scene, we close first the one eye and then the other, it is evident that we shall see slightly different scenes with the respective eyes, the combination of which two scenes gives us a distincter sense of distances and positions, than what would result from observation by either eye separately.

Now, if we place two lenses in positions of distance corresponding with that of the two eyes, each will be capable of pro-

ducing an image corresponding with those seen by the separate eyes. And if these pictures be placed side by side before the eyes, and each be looked at by one eye separately, these two images may be combined by the brain, precisely as the two views seen by the eyes in observing a landscape. Such pictures are made in the *stereoscopic camera*, in which, however, the lenses are placed somewhat farther apart than the distance which separates the human eyes, it having been found by experiment that the effect so obtained is more striking than if the actual distance between the eyes were maintained with the lenses, which also it would not be easy to carry out in practice.

All the operations with the stereoscopic camera are precisely the same as with the ordinary, except the mounting of the prints when finished. These should be cut with care to a convenient size, keeping the centres of the cut prints to correspond as nearly as possible with the point directly opposite the centre of the lens.

In pasting, they must be reversed, that is, the print which is on the right hand side as printed, must be mounted left. It has, however, been shown that this may be avoided by cutting the sensitized paper to twice the length of the negative, and folding its ends till they meet at the centre.

The figure represents the paper loosely folded. *B* and *C* are pressed down till the edges *E E'* meet. The sensitive side of the paper is outermost. Apply the side *B C* to the negative; a print is taken. The sheet is then turned round and the other side printed. Cutting through at *A*, and opening out, *B* and the piece behind it give one print, and *C* and that behind it, another, each with the sides correctly placed for mounting, and not needing to be reversed.

A pair of stereoscopic views may be obtained with a single lens. The two views are taken separately, and the camera moved a little laterally for the second view.

The stereoscope, which for some time enjoyed an almost unbounded popularity, has latterly been much less prized. Larger views, from half size to 10×12 , are capable of so much more artistic effect, that they are taking the place, and deservedly, of the stereoscopic slides, and will, no doubt, increasingly in future.

Fig. 120.

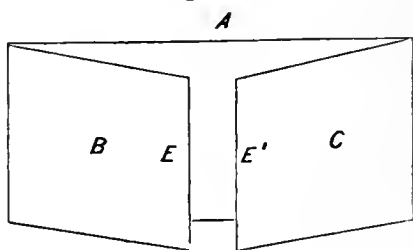

CHAPTER XI.

MICROPHOTOGRAPHY AND MICROSCOPIC PHOTOGRAPHY.

THE first of these processes has for its object the production of extremely small images of objects intended to be viewed by the microscope. The second is the impression upon a collodion film of the image seen in the microscope.

§ 1.—**Microphotography.**

If a negative be placed in a suitable apparatus, and its image, extremely reduced in size, be thrown by a very short focus lens upon a sensitized albumen plate, that image may readily be developed by appropriate means, and a sharp fine positive image be got, which, when viewed by a sufficient magnifying power, may exhibit satisfactory detail if all the manipulations have been well performed. The process evidently involves no real difficulty, except that the image is so exceedingly small that its development requires to be followed by the microscope.

The form in which this description of work first attracted public attention was in the reproduction of objects which, by magnifying, were made to exhibit striking details, lettering, for example. A monumental tablet, for instance, reduced until much smaller than a pin's head, when placed under the compound microscope, showed many lines of lettering, all perfectly distinct.

Subsequently, however, M. Dagron gave a new impetus to the matter by substituting for the microscope a modified Stanhope lens, having one end a plane surface, to which the microscopic print was attached permanently by Canada balsam. These lenses were manufactured out of glass rods at an infinitesimal price, and enormous quantities have been sold in Paris. In this country they have attracted but little attention.

In the late war between Germany and France, immense use was made of microscopic photographs, by sending them on collodion plates with the aid of carrier pigeons, into Paris.

§ 2.—**Microscopic Photography.**

In microscopic photography the images are enlarged greatly above the natural size. The operation differs from ordinary enlarging, both in its object and method.

In ordinary enlarging, the object is usually to reproduce from a small negative a large paper picture, though we also may obtain enlarged negatives on glass. But in microscopic photography the object is to get negatives, large or small, of microscopic objects, often enormously enlarged.

Dr. Woodward, of the U. S. Army, has far exceeded all other experimenters in this direction, whose results have come under the writer's notice. Amongst other interesting specimens received from him are images of test plates made with different kinds of light. The effects obtained with sunlight are altogether inferior to those yielded by the artificial lights, and of these the magnesium light and the electric light obtained with carbon points gave better results than the calcium light; even the latter, however, proved itself far superior to sunlight, the inferiority of which last could hardly have been anticipated in the absence of decisive tests.

A powerful beam of light, from any of these sources, is thrown through a compound microscope, and the image is received upon a sensitized collodion film. An ordinary nitrate bath was used by Dr. Woodward, with the author's collo-developer (see p. 164) and an after-intensification with Schlippe's salt, or with mercury.

By these methods Dr. Woodward has been "enabled to produce pictures of the utmost sharpness, and perfectly satisfactory in every other respect, with powers up to two thousand and five hundred diameters, and these pictures bear a further enlargement of from six to eight diameters in a copying camera. We have thus obtained excellent pictures up to ten thousand diameters."

Ordinary collodions were found to work very well. For great enlargements, where the light was weak, a collodion containing two grains of bromide of magnesium and five of iodide of magnesium was found useful, the deliquescent action of the nitrate of magnesium formed preventing the drying of the film.

With the very highest powers, such as Powell & Lealand's one-fiftieth objective, the correction of the objective to suit the violet light was found to be so small as to be practically unimportant. But with one-eighth, for example, it was found to be

essential. As a general thing, images taken with the one-eighth and enlarged, gave results as good as those obtained directly with the one-fiftieth.

Drs. Woodward and Curtis have obtained many valuable microscopic photographs by this process, which is exceedingly well adapted to increase our knowledge of the structures of animal and vegetable tissues. The writer has received from them beautiful enlargements of minute bloodvessels and blood-corpuscles, etc. One of their most successful amplifications has been that of the *Pleurosigma angulatum*, of which they have obtained good photographic prints on paper, magnified up to nineteen thousand diameters.

CHAPTER XII.

DEVELOPMENT ON PAPER.

§ 1.—Positive Development on Chloride of Silver.

DEVELOPMENT on paper requires to be differently managed according as we wish to obtain positives or negatives. These operations will be considered under different heads, commencing with positives.

Positives may be developed on paper with the aid of either iodide, bromide, or chloride of silver, or with a mixture of these substances. From his own trials, the writer long since decided on chloride as being the best, and the process published by him several years ago has been largely adopted with or without considerable variations.

If paper be impregnated with chloride, bromide, or iodide of silver, be exposed for a short time under a negative, and then be thrown into a saturated solution of gallic acid, a picture will soon be developed, which will go on increasing in strength, and, when satisfactory, may be taken out, washed, and fixed. Such was the original idea of development, which we owe to the late Rev. J. B. Reade, though it was shortly after taken up and perfected by Mr. Fox Talbot, to whom, by many, it has been ascribed. Both these experimenters operated with iodide of silver, and turned their attention rather to negative development than positive. Some years later, Blanquart Evrard took the process up, used a mixture of bromide and iodide of silver, fumed with hydrochloric acid, and toned his pictures with hyposulphite and

gold. His results were magnificent, and for a while it was asserted that none of his pictures had ever been known to fade. With increasing lapse of time, however, this has ceased to be true, and his pictures have in some cases faded.

The process which the writer brought forward was based upon the use of lead in connection with gallic acid. It had been known before that the addition of acetate of lead to gallic acid greatly increased its powers of action, but as a precipitate was formed, rendering the liquid muddy, this objection interfered with the use of the lead salt, and the fact remained without application.

Having ascertained that gallate of lead, the precipitate formed when acetate of lead was added to gallic acid, was soluble in acetic acid, the writer applied this observation to development both positive and negative, and with excellent results, especially in the former case. The economy of gallic acid was enormous, the rapidity of development was heightened, and, what was of far more consequence, the clearness of the development was greatly enhanced, so that of all kinds of development, this was the safest and least liable to accident. The course was so regular and uniform that many prints could be developed at once, and the bath kept in working order for a longer time and with a greater number of prints. This was probably because the large quantity of acetic acid used restrained the precipitation of the silver, whilst the action of the lead expedited the development.

The following are the details of this process.

For a twenty-four ounce developing bath, dissolve four grains of gallic acid in a few ounces of water, and add about half an ounce of a solution of acetate of lead, thirty grains to the ounce, of which a stock may be conveniently kept on hand. A thick white precipitate falls. Next add acetic acid till this precipitate redissolves—a little excess of acetic acid does no harm, but is rather beneficial. Filter this and dilute to twenty ounces. To four ounces of water add a few drops of solution of nitrate of silver from the positive printing bath, and mix with the rest.

These various operations should be performed a short time only before the bath is wanted, as naturally it will not keep.

The development may be effected either on plain or on albumenized paper. It is commonly believed, universally it might be said, that development on albumenized paper is impossible, but this is a mistake. The treatment of the paper must be different, but either sort will develop in the foregoing bath.

To develop on plain paper, float it for one minute upon a five-

grain solution of sal-ammoniac. Sensitize on a nitrate bath acidulated with tartaric acid, as follows:—

Nitrate of silver	1 ounce.
Tartaric acid	26 grains.
Water	13 ounces.

Good results can be obtained with half this strength, but for general use it is not advisable to economize the silver so much. It is almost superfluous to say that this sensitizing, and the placing in and taking out of frames, will be performed in a room by yellow light, and not as in the preparation of ordinary positive paper. The same care in excluding white light as in the wet collodion process must be exercised.

The paper, when dry, is placed under a negative and exposed to light, direct sunlight is best, for from fifteen to sixty seconds, according to the light, the season, and the negative. The writer advises to continue the exposure until the image reaches a pale chocolate color. Some stop at the pale violet. Good results are got either way, but the former seems preferable. Of course the frame must not be opened for examination.

It is a mistake to assert, as some have done, that no details are got in the development that were not visible faintly in the print when taken from the frame. On the contrary, much that is not any way visible, comes out distinctly in the development.

In fact, the writer has proved this capacity of chloride to yield details in development, which were originally invisible, in rather a striking manner. A piece of paper sensitized with a chloride only, was taken and placed behind a negative, and a single magnesian spiral was burned at a little distance. On removing the paper nothing was visible, but the careful application of a developer brought out the image with all the details, in a surprising manner. The details were as full as if iodide of silver had been used, but the picture was very flat.

When, then, the print is judged to have been sufficiently exposed, it is removed from the printing frame, and plunged evenly and quickly into the developing bath. With the bath above described, the development requires about five minutes to complete it. The prints should generally be stronger than they are intended to be when finished, for they lose in the fixing.

As soon as the print is judged to be sufficiently developed, it is thrown into water to stop the action, and is then toned with gold precisely in the same way as with any other positive on paper. If not toned, it will have an unpleasant coppery color,

which seems almost unavoidable in developed prints. The writer has, however, obtained a pleasant purple tone by using serum of milk (whey, see foot of p. 264) in the salting of the paper.

It will be seen that the above bath, though containing only one-sixth of a grain of gallic acid to the ounce, acts much like an ordinary developing bath, made twenty times stronger. This shows how remarkable is the agency of lead in increasing the activity of gallic development.

For albumenized paper a larger dose of tartaric acid is advisable. Take—

Nitrate of silver	1 ounce.
Tartaric acid	36 grains.
Water	12 ounces.

Float on this ordinary albumenized paper for two to three minutes, and then proceed otherwise as before.

Paper prepared in this way, although albumenized, bears development very well, and gives good results. Not so good, however, either on albumenized or plain, as with sun-printing, though sometimes not far behind. Still, it must be said that when the sun's light is left to do its perfect work, that work is better and more completely done than when we break it off just commenced, and force our solutions to complete it. It would seem that it could not be otherwise. There is less depth in the shadows and less brilliancy. The developed print is apt to be softer than the direct sun print, and shows less contrast; it is also more sunk in, and shows the grain of the paper more. And, although the development can be effected on albumenized paper, it is more difficult and less certain than on plain.

This last described paper has good keeping properties. If placed in a tight tin case, thoroughly protected from light, it shows but little tendency to spontaneous decomposition, and I have succeeded in developing a perfectly clean picture, after an interval of at least ten days after sensitizing.

§ 2.—Negative Development on Paper.¹

Calotype Process.—Float paper on a 20-grain plain solution of nitrate of silver, and then, after drying, upon a 25-grain solution

¹ An interesting negative process on paper, by Mr. H. J. Newton, will be found in the *Philadelphia Photographer*, vol. iv. page 187. The writer regrets that space will not allow him to extract it in full.

of iodide of potassium; on the first solution for one minute, on the second, ten minutes. Dip in water to wash off the excess of iodide and dry. In this condition the paper keeps well, if protected from light.

Make now 6 ounces of cold saturated solution of gallic acid, dissolve 300 grains nitrate of silver in 6 ounces of water, mix the two and add an ounce of strong acetic acid. No more of this sensitizer should be made than is needed, as it will not keep more than a few hours. Therefore, in sensitizing a few sheets it is better to make much less and brush over the paper instead of floating. Whether dipped or floated, the solution is left on but a minute; the sheet is dipped into water, the excess of moisture blotted off with bibulous paper, and the sheet is ready for use. A very brief exposure is sufficient to form an image which will go on strengthening in the dark, or may be hastened by washing over with the sensitizing mixture, just above described, and holding to the fire.

This process gave excellent results, and was long a great favorite, until the collodion process superseded it. The negative so obtained may be paraffined as follows.

Paraffining.—Take a fine translucent paraffine candle—not the paraffine that resembles spermaceti, but the very translucent sort—and scrape it down to shreds with a knife or piece of broken glass. Strew some of these on a piece of filtering paper, lay the negative upon them, put more shreds on the negative, then another piece of filtering paper, and iron with a right warm, but not hot, flat-iron. If on looking at the negative it is not found to be moist all over, put more shreds on the dry part, and repeat.

Wax Paper Process.—Legray showed that paper might be first waxed, and that, even after this, it would take up sufficient iodide of potassium if immersed in the solution, to admit of sensitizing on solution of nitrate of silver and exposing in the camera. Serum of milk, or whey, was found useful in this process, and the writer has used it with good effect in developing positives. After waxing good photographic paper with fine bleached wax, soak it for an hour in—

Serum of milk	25 ounces.
Milk sugar	½ ounce.
Bromide of potassium	48 grains.
Iodide of “	180 “

To obtain whey, heat the milk to boiling, add a very few drops of acetic acid till it turns, then the white of an egg to clear, and

filter through paper. Milk sugar can be had of the druggist. Dry and put away between folds of paper. Sensitize, when wanted, on a thirty-five grain solution of nitrate of silver to which glacial acetic acid has been added in the proportion of one ounce of acid to fourteen of bath. Immerse in two waters successively, dry between folds of blotting-paper. Expose in the camera either between two pieces of plate glass, or else paste the edges of the paper over the edges of a piece of glass. Develop with a saturated solution of gallic acid, to which nitrate of silver has been added in the proportion of one grain to two ounces of gallic acid solution and a little acetic acid. Probably the lead developer, already described, would be every way better. (See section 1 of this chapter.)

§ 3.—Paper Enlargements.

Life-sized portraits may evidently be obtained in the same way as ordinary portraits, provided we proportionately increase the size of the lens. But unfortunately the defects of lenses increase with their size, and this is especially true with respect to depth of focus. The larger the lens, therefore, the more difficult it will be to get different parts of the subject simultaneously in focus, and consequently, while it is by no means impossible to take life-sized portraits direct, it is much more common to effect this object by enlarging, with the aid of a solar camera, from a small negative, generally made expressly for this purpose (see p. 177).

Enlargements, printed by the solar camera, may be finished in the camera, that is, the whole work may be done by sun-printing, precisely like printing in a frame. But the method of development is also practicable, and this may be done in the manner already described, by chloride development, or, at the option of the operator, the negative process on bromo-iodized paper may be used, of course without taking means to render the paper transparent. But as the negative process is specially intended for those cases where the illumination is very weak, as in the camera obscura, and as the light of the solar camera is always abundant for chloride development, that process will give the most satisfaction, provided, as before said, that the operator desires to develop, and not to finish in the usual way. Also when the picture has been supposed to be finished, and has been found to be too weak, development may be resorted to to bring it up.

§ 4.—The Solar Camera.

The apparatus for enlarging from a small negative may be arranged in several different methods; these instruments are known as solar cameras.

Woodward's Camera.—In this instrument the solar rays are received upon a mirror of silvered (not quicksilvered) glass, whose office it is to reflect them horizontally. They then pass through a plain convex *flint* glass condenser of eight inches in diameter.

Fig. 121.

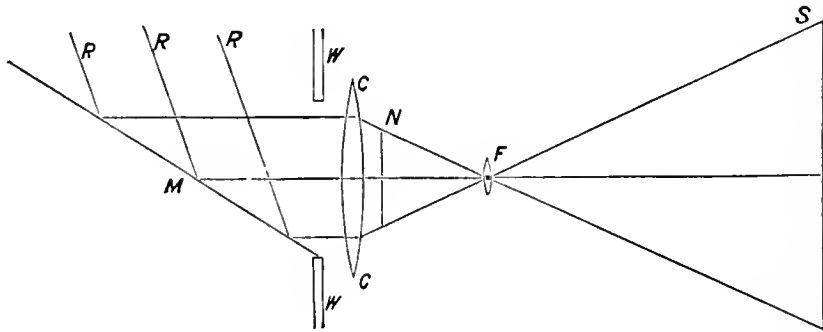

R R R, parallel rays from the sun falling upon the mirror *M*, which reflects them horizontally through the opening in the wall *W W* of an apartment. Inside is the condenser *C C*, which converges them to a focus *F*, where a photographic objective is placed. A negative *N* being interposed between the condenser and the objective, its magnified image is formed on the screen. In Woodward's apparatus the lens at *F* is an ordinary portrait objective.

The mirror *M* is mounted with racks and pinions, and requires to be moved every few seconds to keep the rays horizontal.

Van Monckhoven's Camera.—The objection made to Woodward's apparatus has been that the condenser was not large (eight inches diameter), and consequently the working was slow. The size could not be increased without introducing much spherical aberration and injuring the sharpness of the image.

To avoid this evil, Van Monckhoven introduced a negative lens behind the condenser, a thin meniscus, and also replaced the objective by one of a construction devised by himself.

Light is thrown upon the apparatus in the same way as with Woodward's. Or a *heliostat* may be very advantageously applied to any solar camera. In this instrument the mirror is regulated

by clock-work, so that it moves with the sun and takes always such an angle that the rays reflected by it fall horizontally upon the condenser.

Very good work has been executed with Van Monckhoven's camera.

Other Solar Cameras.—The same optical principle which was adopted by Woodward, has been made the basis of a number of different arrangements, by Shive, Roettger, Fontayne, Gales, Carbutt, and others. In Shive's, Roettger's, Fontayne's, and Carbutt's the direct rays of the sun are used without a reflector. The difference in these instruments depends upon the mechanical contrivances applied to carry out the optical arrangement. In all a plano-convex lens is placed with its convex side to the light. Between its posterior surface and its focal point the negative is introduced. At its focal point the photographic objective is placed, and the image is thrown upon a screen in the back of the camera. Roettger claims for his, to which he gives the name of "parallactic," a greater facility for following the sun's path. The most recent modification is Carbutt's, which is itself a modification of Stuart's; in it the whole tripod moves. The base of the tripod is a triangle, moving upon a hinge at one corner. The corner falls directly under the condensing lens; this gives a facility for making a great angular movement in a very little space. The apparatus is mounted permanently in a room at the top of the house. A section is removed from the south end of the roof, to admit the direct sunshine.

It will be seen that the only modification of the optical principles of Woodward's camera which has been made is that of V. Monckhoven, who introduced the negative meniscus into it, to correct the spherical aberration, and thereby enable him to use a larger condenser. The size of the condenser is of material importance, for on it depends the intensity of the image. Woodward's condenser was eight inches in diameter, while V. Monckhoven was enabled to raise his to twenty. The time required for printing an enlargement of a given size with the two would be approximately inversely as the squares of the diameters, namely, as 400 to 64, or as 6 to 1, or thereabouts.

§ 5.—Printing by the Solar Camera.

Little special need be said on this head. Albumenized paper is attached to the screen, and the image gradually appears, requiring a time which may extend from half an hour to many hours to reach full strength.

This slow printing, requiring, as it does, incessant attention to keep the apparatus duly placed as respects the sun, unless the operator possesses a heliostat, is very objectionable and annoying, and therefore leads to the extensive use of development in order to shorten the time. This part of the subject has been already explained.

Efforts have been made to shorten the time required for sun-printing. That of M. Van Monckhoven, founded upon the use of *nitroglucose*, has been well spoken of, but does not seem to have passed into general use. The nitroglucose process may be used either for direct printing or for enlargement.

Nitroglucose is prepared by adding one part of pulverized sugar to one of sulphuric acid previously mixed with one of monohydrated nitric acid. After an action of about five minutes, the mass is to be removed from the acid and washed with cold water. This crude nitroglucose is to be purified by dissolving in alcohol and precipitating by adding water, in which it is insoluble.

This nitroglucose, according to Dr. V. Monckhoven, does not precipitate nitrate of silver, but acquires that property if its alcoholic solution is kept for eight or ten days at a temperature of 110° F. Its application is as follows: the paper is passed through an alcoholic solution ten grains to the ounce, is hung up to dry, and is then immersed for two hours in an ordinary salting solution. Next, sensitized on a twenty-five grain plain solution of nitrate of silver, and hung up to dry. So prepared, it keeps for many months.

In use, the paper is exposed in the solar camera for about a minute, and is then developed with gallic acid five grains, water ten ounces, glacial acetic acid fifty minims. The author of the process claims for it that a gallic development causes *albumenized* prints to turn yellow in the whites, whereas with the nitroglucose process the whites remain perfect. Now, when the development on albumenized paper is carefully conducted on the principles laid down in this manual, the whites do not turn yellow. More-

over, V. Monckhoven observes that the operation for making nitroglucose is so delicate that the method would be useless were it not for a modification discovered by him, and as yet unpublished.

The writer has himself prepared nitroglucose, and found no difficulty whatever in it. He has found it advantageous to substitute *fuming* sulphuric acid for one-half of the ordinary acid. The mixed nitric and sulphuric acids must be allowed to cool thoroughly in a covered vessel after mixing, powdered white sugar is then stirred in, enough to make a thin paste. Soon a kind of grayish dough makes its appearance, which is at once removed with a spatula and thrown into water. This is continued till the dough ceases to form, when a little more sugar may be added, though its yield will be much less in proportion than that of the first.

The nitroglucose must at once be kneaded up with water to get out the excess of acid with which it is saturated, and which by remaining in it might cause its decomposition. For completer purification, the nitroglucose is dissolved in alcohol and precipitated by water. The alcoholic solution should be poured into water (not the reverse), with constant stirring. The nitroglucose separates a thin dough, which is to be washed by agitating with several waters, and then should be kept under water.

CHAPTER XIII.

SILVER PRINTING.

ELEMENTARY directions will be found in the Introduction. Here will be given some special remarks on the various branches into which the subject divides itself, including the description of a new and hitherto unpublished method of sensitizing paper for positive printing, recently devised by the author, and which has for its object the preparation of paper which can be kept for a long time after silvering, without deterioration, and ready for use at any moment. (See sec. 6.)

§ 1.—Selection of Paper.

The paper preferred in this country almost universally is the Saxe paper, of which the genuine is manufactured by Steinbach,

and of which there are many imitations. Some of Marion's paper is also sold here, often as "Saxe paper," even as the writer has seen done, with Marion's name water-marked on the edge. "Rive" paper is little known here, nor Canson. Whatman's paper, much liked in England, especially for negative work, scarcely finds its way to this country.

The qualities required in paper are—to be made of good stock—that is, fine clean rags; to have had the chlorine used for bleaching thoroughly removed, as also the antichlor (generally hyposulphite of sodium). Chlorine left in the paper tends to injure the fibre, but is otherwise of little importance, but even the slightest traces of hyposulphite make ineffaceable stains and discolorations. A print thrown by mistake into hyposulphite washings, turns black all over, the hyposulphite being decomposed, and sulphide of silver formed; of course a similar reaction takes place when hyposulphite is left in the paper—faint traces make brownish spots, visible in the sensitized paper before printing.

Again, the paper must be free from all kinds of metallic grains, which, without care, are liable to drop into the pulp. Metallic dust, abraded from the machinery, forms imperceptible specks, which, however, reduce the silver from the nitrate bath, and make spots in the print.

In this country, prints are almost universally made upon white paper, but rose, purple, and other tinted papers are being introduced, and serve to give an agreeable variety.

§ 2.—Albumenizing Paper.

Few operators take the trouble to albumenize their own paper. But as original experimenters require to understand every portion of the process of photography, and as it may happen that photographers may desire to print where albumenized paper cannot be got, the writer gives the formula which he has used with good results.

Take the whites of perfectly fresh eggs and add thereto liquid ammonia in the proportion of five drops for each egg. Measure the quantity, and take six grains of sal ammoniac for each ounce of albumen. This may be dissolved in an ounce of water for each five eggs, or if very high albumenizing is desired, it may be dissolved in the smallest possible quantity of water.

Add the sal ammoniac solution, and let the whole be beaten up

to a froth, so that no liquid portion be left. Set away for twelve hours or more (a cool damp place is best), and pour off the liquid portions which have settled out of the froth. These are perfectly clear and free from foreign matter.

The albumen thus prepared is placed in a flat pan and the papers rested on it for three or four minutes, and then lifted off and hung up to dry. The faster the drying the higher the gloss, and therefore these papers, when prepared commercially, are often dried in rooms kept at a suffocating heat.

In small experiments, the albumen may with a little dexterity be applied with a broad (two-inch or more) camel's-hair brush. With care, streaks may be avoided.

Some have recommended the use of glacial acetic acid (three drops to each egg) instead of the ammonia. Lyte remarks that this tends to yellowness in the whites of the prints, and the author's experience has been the same.

In salting, considerable latitude is allowable. Eight or ten grains of sal ammoniac is about an average quantity, which is sometimes reduced to six, sometimes increased to twelve. An absurd secrecy is practised by many makers of albumenized paper as to their salting, and this introduces some uncertainty as to the proper treatment: strong salting requires a stronger bath, and with paper of which the salting is not known, some trials may be requisite to determine the appropriate bath.

The weaker the salting the less is the exhaustion of the positive printing bath, but it is not quite sure that the pictures so produced are quite as permanent.

In the preservation of albumenized paper, two things are to be borne carefully in mind. First, that if the paper be kept in a moist atmosphere, it will not give brilliant prints. This is because the salt used becomes to some extent dissolved in the hygroscopic moisture absorbed by the paper, and is drawn by capillary attraction into the body of the paper; thus the silvered surface is less perfect. This is more the case with common salt, chloride of sodium, and less with chloride of barium, than with chloride of ammonium. Common salt is the most deliquescent, chloride of barium the least soluble of the three.

On the other hand, excessive dryness is to be avoided, the coat of albumen becomes too horny and not sufficiently permeable. Many adopt the plan of keeping the stock of albumenized paper in a thoroughly dry place, but take out what will be wanted for

one day's printing, and leave it twenty-four hours in a damp cellar, in order that it may take the nitrate bath more evenly.

Generally speaking, the fresher the paper the better, and the less chance of defects. To be sure of obtaining the quality of paper desired, it is best to purchase directly from the maker or his authorized agent.

Decomposed albumen is always hurtful. If it be kept so long before applying to the paper as to acquire a bad smell, it must be rejected. And if the paper be kept in a very moist place, the albumen may putrefy on the surface of the paper.

§ 3.—Salting Plain Paper.

In salting ordinary paper, the most various proportions of salt have been recommended. Two, three, or four grains to the ounce are about a recommendable proportion, and give good results. A little gelatine may be advantageously introduced; the latter should not exceed two grains to the ounce, and may be less. It will need the aid of heat to get it into solution. If not over one grain be used, the liquid will scarcely gelatinize in cooling.

The following may be taken:—

Chloride of ammonium	50 grains.
Gelatine	16 “
Water	10 ounces.

By some, chloride of barium is preferred. The greater equivalent weight of this substance requires that it should be used in larger proportion. As follows:—

Chloride of barium	200 grains.
Gelatine	45 “
Water	30 ounces.

A difference of opinion exists as to the proper mode of preparation. High authorities recommend that the paper be drawn through the solution. But as it is the invariable object to keep the materials on the surface, it is perhaps better to float the paper for a few moments in the bath. In any case, it is desirable that it should be rapidly dried, before the solution soaks too much in.

Arrowroot paper may be purchased ready salted. The effect of the arrowroot is to keep the picture more on the surface, and so avoid a sunk-in, mealy effect. If warm tones are wanted, use the benzoate or acetate toning; if black, the lime. These papers

need vigorous printing, and should not (according to Liesegang) be toned in a fresh toning bath, but only after some albumen prints have been toned in it.

Good results may be obtained by floating albumen paper with the albumen side up. This gives the print a good deal the effect of being made on plain paper very highly finished. There is not the transparency of shadow which makes the peculiar beauty of the albumen print, but there is also less gloss and glitter.

§ 4.—Sensitizing.

Since the first edition of this book was published, fuming with ammonia in one shape or other has come into general use, and with this change the practice of making the “ammonio-nitrate bath” has comparatively passed out of use.

When paper is to be fumed, it is not very important whether the sensitizing bath is acid or alkaline, because the fuming always renders the paper alkaline, either beforehand, as when the fuming box is used, or during the exposure, or when fumed pads are employed. The usual strength of the bath is now 50 to 60 grains of nitrate of silver to the ounce. A satisfactory bath will be:—

Positive Bath.

Nitrate of silver	3 ounces.
Water	24 “

The usual practice is to make this bath faintly acid with nitric acid, though some excellent operators make it slightly alkaline with ammonia.

On this bath the albumenized paper is to be floated about a minute—a little less in hot weather, a little more in cold.

After the sheet has floated for a proper time, it is to be pinned or otherwise fastened up to dry. Buff shades to the room, if wide enough to cover the window jambs, will be a sufficient protection; if too much white light be admitted, the high lights of the prints cannot be expected to be satisfactory. In some establishments a table is provided with a back or screen towards the left, seven or eight feet square. This protection, and keeping the sensitized paper and prints in drawers, is found sufficient, provided that the table is near a wall, so that but little diffuse light can pass round the screen.

Consumption of Nitrate of Silver.—Different photographers have calculated the amount of nitrate of silver consumed in sensitizing an albumenized sheet of 18×22 , and have varied between wide limits, some fixing it as low as 60 grains, others as high as 110 or over. Seventy-five to eighty grains is probably about the true quantity that is abstracted from the silver bath, part of which is subsequently recovered from the washings.

Alum in the Printing Bath.—Mr. H. T. Anthony recommends the addition of alum to the bath; about 2 grains to the ounce of bath seems to be the right proportion, and to tend to keep the bath clean and free from discoloration. By this means, he states, he gets as good results from a 35-grain bath, as on the old plan with a 50-grain. He advises, after the printing is done, to soak the prints in water acidulated with acetic acid, before toning them.

Blotting Sensitized Paper.—Some very successful workers blot all their paper, to obtain equal action and avoid drops of bath solution collecting on the surface in drying. Thick blotting pads are provided, rather larger than the sheets. On one the sensitized sheet is laid face down and pressed, then another pad and another sheet, and so on. The pads may be used many times over before they become too much charged with solution—finally they are burned to recover the silver. The abstraction of the silver solution does not reduce the vigor of the prints, which are obtained very uniform in character and free from stains.

If the paper is allowed to dry between the pads, it will be apt to turn yellow. It is, therefore, best, as quickly as the liquid is completely absorbed, to remove the sheets, pin them up, and let them dry.

Management of Bath.—The positive bath by use soon turns yellow and loses strength. The first trouble is to be remedied by shaking up with half an ounce to an ounce of kaolin, according to the size of the bath. The strength must be kept steadily up to the mark originally fixed, and this is either done by watching carefully the character of the prints, and adding silver liberally as soon as they show any signs of deterioration, or by means of the *argentometer*, a sort of hydrometer expressly made for the photographer, and which, by sinking more and more deeply into the bath, indicates the exhaustion of the nitrate of silver. With the age of the bath, however, its indications become less reliable,

in consequence of the accumulation of other nitrates in the bath.

These, however, appear to some small extent to take the place of nitrate of silver. At least, Meicke's experiments showed that the quantity of silver abstracted from an old bath was less than from a new one, sometimes by as much as 15 or 20 grains to the sheet, and it seems not unreasonable to suppose that the alkaline nitrates gradually accumulating in the bath had something to do with this. A sharp controversy was carried on in England for some space of time over the question of the utility of alkaline nitrates in the bath. Generally, nitrate of soda was tried. The bulk of the rather conflicting evidence seems to have been in favor of the advantage of the addition, a result undoubtedly confirmed by Meicke's experiments above mentioned.

§ 5.—Washed Sensitive Paper.

One of the serious annoyances connected with photographic printing lies in the rapid deterioration of the paper, which quickly turns yellow, thus destroying the brilliancy of the white. It is rarely safe to keep the paper from one day to another, especially in hot weather. Two bad results follow: that if the weather changes from fair to dark, a portion of the paper prepared for the day's use is apt to be spoiled; whilst, on the other hand, if the day changes from dark to bright, there is no paper ready to profit by it.

The preparation of a paper with good keeping qualities has consequently been felt to be an object of the greatest importance. Such paper has been prepared commercially in France; its mode of manufacture, however, has been kept absolutely secret. So far the only published method of obtaining a paper that can be kept is the Washed Paper Process, here to be explained. This process, however, involves a considerable amount of additional manipulation in the washing of the paper after sensitizing it. The writer has lately taken up and finished some investigations commenced some years ago, and has succeeded in finding a method free from this objection, and requiring no more labor to prepare than the ordinary silvered paper, yet sufficiently permanent to be kept for a considerable length of time without deterioration. This method will be described in the next section following.

In the *Washed Paper Process*, the paper, as soon as it is removed from the printing bath, is thrown into water, to remove the excess of nitrate of silver. As to the *amount of washing* that the paper will bear, different operators have reached very different conclusions, and the practice has not been so generally adopted as to have led to the accurate fixing of these conditions. Some succeed best by simply drawing the paper through one water; in this condition it approximates more nearly to ordinary silvered paper. Others draw it through two, three, or even four waters, so that the last water shall show no clouding by reason of chlorides present in it, thus indicating that the whole of the nitrate is washed out. When thus treated, the salting must not be too low, and the silver bath *must be kept well up* to the mark, strengthening, from time to time, with fresh nitrate, according to the number of sheets sensitized. The amount of silver abstracted will depend upon the salting, but for average paper it will be fair to estimate from five to six drachms for each four sheets of paper of 18×22 . After what number of sheets the strengthening will be required will, of course, depend much upon the quantity of bath used, but it is best always to be on the safe side; a rule used by some experienced operators is to strengthen after each five sheets. After each strengthening, try the bath with test-paper, to make sure that it is alkaline, but not too much so. If too alkaline, the albumen will be dissolved off the surface of the paper. If the strengthening of the bath be neglected, the prints will want vigor.

Paper thoroughly washed has been kept, according to M. Baden, from March till October, without deteriorating. When it is intended to keep the paper for a long time, much more care with regard to light must be exercised through the operations of sensitizing, washing, and drying, and in keeping it in a dark and dry place. The prints themselves cannot be kept with the same safety as the paper, because of the fuming before printing, but they may lie over for some days or even longer.

An advantage in using several waters is that the first pan can be used many times, until its contents become very rich in silver, and fit to evaporate down and recover the silver fit for use. Then the second pan receives the first, and so on, fresh water taking the place of that which was previously the last.

The washing of the paper after sensitizing does not take the

place of the subsequent washing, but the prints, after they come from the printing frame, must be again washed before toning.

Care is also necessary with the fuming, which may easily be carried too far. *Pad fuming* (see p. 279) is said to answer best. If the prints are fumed in a box, and are left in too long, they will tone to a cold blue. It is said, however, that this over-fumed paper, by keeping for a day or two, will lose some of its excess of ammonia, and give better tones. *Five minutes* is about the right time to leave this paper in the fuming box.

The high salting of the paper above spoken of, appears to be essential. This introduces a difficulty, inasmuch as the photographer rarely prepares or knows how much salting is contained in the paper that he habitually uses.

It will be easily understood, from the foregoing, that there is more or less uncertainty connected with this method. Some have obtained very satisfactory results with it, whilst others have been disappointed and have rejected it. This uncertainty, and the considerable additional manipulation required, appear to render the method much less advantageous than the following.

§ 6.—New Method of Sensitizing Paper.

Some years ago the writer, whilst investigating the subject of Paper Development, ascertained that by the addition of *tartaric acid* to the sensitizing bath the paper could be kept for ten days. As paper for development is still more liable to deterioration than that prepared for positive printing, it appeared to him likely that this property of tartaric (probably also of citric) acid might be made the foundation of a new printing process of great utility. Other occupation, however, interfered with the prosecution of the matter till recently, when the experiment was tried, and with complete success. At the time when this sheet goes to press, the writer has kept this new paper about *seven weeks*, at the expiration of which time it was still in excellent condition, giving brilliant prints with whites just as perfect as when freshly made, and toning with the utmost ease.

Formula.

Crystallized nitrate of silver	2 ounces.
Tartaric acid	40 grains.
Water	16 ounces.

The nitrate and the tartaric acid are not to be thrown into the water together, but dissolved in separate portions, mixed, let to stand some hours, and then filtered. This bath is then used and treated precisely like an ordinary printing bath, except that it is best to keep it out of the light. The albumenized paper is floated for the usual time and hung up to dry. More care should be taken in excluding the light than in the case of ordinary silvered paper intended to be used at once, and when the paper is dry it is to be put aside in a close-fitting box and kept in a dark, dry place until wanted for use.

Sometimes the author adds—

Gelatine	4 grains,
Glycerine	3 drops,

to each ounce of the bath. The gelatine should be set to swell in a part of the water, and then be dissolved by warming, add the glycerine and tartaric acid to this, and pour it into the rest of the water in which the silver-nitrate has been dissolved. Although the bath now contains four grains of gelatine to the ounce, the tartaric acid prevents any gelatinizing, even if one employs, as the writer has sometimes done, a much larger proportion of gelatine. It also filters easily. When gelatine is used, the prints as taken from the frame have a bright brown color; they tone to any shade desired as easily as the others. The use of gelatine would seem to tend to keep the print more on the surface, but whether there is any real benefit in it is scarcely certain. Perfectly satisfactory prints are obtained without it. The object of the glycerine is to remove the stiffness which the gelatine tends to give the paper.

The fuming is done shortly before using, and requires no particular care, and the print is washed and toned in any of the ordinary methods. The writer uses the acetate toning bath. What is rather curious is that while the albumen side of the paper remains white, the back often acquires by keeping a brownish coloration, which, however, disappears entirely in the toning or fixing, and no one, in examining either the face or the back of the print, could distinguish it from one made on paper just dry after the printing bath. It seems possible that the quantity of silver in the bath might be reduced, but in these examinations it was thought better to adhere to the proportion of silver actually employed by the most successful workers with the ordinary bath.

It will be seen from the foregoing description that paper with excellent keeping properties is as easy to prepare as paper that spoils immediately. It is only adding a few grains of tartaric acid and proceeding otherwise precisely as usual. The advantages are very great and the trouble nothing. The method will, the author trusts, be found a valuable alleviation to the troubles of printing.

§ 7.—Fuming.

A convenient and close-fitting wooden or tin box is provided with a door, and either pieces of cork are attached to the sides near the top inside, or else cords are stretched across. To these the dry sensitized paper is attached for fuming. This operation lasts for ten minutes, and is best performed only a few minutes before printing. If the fuming be too much prolonged, the print may be expected to be flat and mealy, and to be severely reduced in the fixing bath. On the other hand, an irregular spotty effect indicates insufficient fuming.

In a saucer at the bottom of the box is poured some strong liquid ammonia. The quantity is not very important; for a small box and a dozen or twenty quarter sheets of paper, an ounce and a half to two ounces will be sufficient. For a large box and twenty or thirty whole sheets, two dishes with two or three ounces in each will be sufficient, if the ammonia be good. (The liquid ammonia of commerce is very variable in strength.) Carbonate of ammonium has been recommended by Dr. Liesegang as an advantageous substitute for the liquid; the mode of operating is precisely the same, except that a larger quantity is employed, and may be used many times.

It is best that the fumed paper should be exposed to the air for ten or fifteen minutes, to allow the adhering ammoniacal fumes to pass off, before laying upon the negative.

The effect of fuming is to give rich, brilliant prints with ease and certainty. This method, now in very general use, was first proposed by Mr. H. T. Anthony.

Pad Fuming.—Another plan, which has lately been a good deal used, is to fume *pads* instead of the sensitized paper. These pads are left for some hours, or over night, in the fuming box, and are placed behind the silvered paper whilst it is in the printing frame. In this way the ammonia acts upon the silvered

surface during the operation of printing. The influence of this fuming can be heightened by putting pieces of oiled silk directly behind the fumed pads, in order to prevent all escape of ammonia. Another plan has been recommended, that of simply rubbing the pad with a lump of carbonate of ammonia, taking care, of course, to leave no grains or dust on the pad.

Fuming with a pad is less likely to injure valuable negatives than fuming the paper itself.

§ 8.—Printing.

Before placing the paper in the frame, it is necessary to be certain that it is perfectly dry, otherwise the negative may be injured; a careful examination should be made of every part of the sheet before it is cut to pieces, bearing in mind that a single moist spot may cost a valuable negative. The paper, especially if albumenized paper be in use, must be set in the frame neither roughly nor carelessly. For it is to be always borne in mind that a negative is a delicate thing. Even the best varnish is no protection against rough handling, and a slight scratch may easily occur in some place where touching out may be either impossible or nearly so. The paper should never be drawn over the plate, especially when pressed close to it. It must be laid flat down in its proper position, and the pads laid easily and squarely down upon it and secured by the back.

Printing may be done either in the direct rays of the sun or in diffuse light; the choice between the two will depend upon the nature of the negative, and the preparation of the paper must be regulated accordingly.

The characteristic of printing in the sun is softness, of printing in the shade, strength and contrast. Nevertheless, prints made in sunshine are mostly the stronger, simply because strong, hard negatives require sun-printing. And so, soft prints will often be found to have been executed in the shade, because taken from very thin negatives which could not be made to yield a good print in any other way. For want of understanding this, very contradictory and erroneous statements have often been published on the subject of sun and shade printing.

A photographer will, for example, start out with the intention of printing in the shade, and will make all his negatives very thin with that intention. If these negatives were printed in the

sun, the prints would be utterly worthless. By the time that the shadows were deep enough to stand toning and fixing, the lights would be discolored and the prints spoiled. To examine his prints and observe his mode of printing might lead to the conclusion that shade-printing gave soft prints, whereas the fact would be that the thin negative gave soft prints in spite of the mode of printing.

Another will prefer bold, vigorous negatives, and will develop and redevelop till he gets them. These, if printed in the shade until details were got in the high lights, would lose all transparency of shadow, which would be converted into black patches. The exposures would be tedious and the prints bad. But exposed to a bright sun, the intense rays pierce through the dense parts of the negative, and give us the details in the lights before the shadows are overdone.

Under the head of Salting, it has already been remarked that both the salting and the nitrate bath must be regulated so as to act as a counterpoise to the printing. With a thin negative the bath must be a rich one, or the picture will tend to flatness. A bold negative will print well upon a less highly sensitized paper. In this lies the explanation of the much discussion over strong and weak printing baths, some succeeding with what fails with others, all depending upon the nature of the negative. Again, when, by accident, a very hard negative is taken, which gives a harsh black and white picture, its prints may be improved by using an extremely weak sensitizing bath (prolonging the floating of the sheet upon it proportionally). Extremely hard negatives, so hard as to be unserviceable in any other way, are made to yield good prints by washing the paper after sensitizing it, so as to remove all free nitrate, then drying and exposing.

Very thin negatives, that only give flat prints under the ordinary treatment, may often be made to yield excellent prints (provided they are not actually deficient in detail in the shadows, so that they are wanting in density only, not in graduation; the distinction is important) by printing under one or more folds of tissue-paper.

It will easily be understood that where negatives are printed in large quantities for sale, they are likely to give better results, because the treatment for any particular negative, in respect to salting, sensitizing, and exposing, can be well made out.

The proper degree of salting will always depend upon the

strength of the sensitizing bath, and correspond with it. A rich nitrate bath should follow high salting, and the reverse. Where it is wanted to get a soft print from a very hard negative, the salting may be reduced to one or two grains per ounce of water or albumen, to be followed by a weak printing bath of twenty to thirty grains nitrate of silver.

Another remark of importance is this, that the image produced by a strong light stands the subsequent operations better than that produced by weaker light. A print made in direct sunshine is less reduced in toning and fixing than one made in the shade. Consequently, a shade-print requires more over-printing in the frame than a sun-print. The sun-print is undoubtedly the stronger picture of the two, and the writer holds that, other things being equal, its chance of permanence is greater than that of the shade-print.

The *time* required for printing will of course vary extremely; in extreme cases, from a minute or two to many hours. The prints are to be examined by carrying the frame to a dark corner, loosening one end of the back, opening it and observing the condition of the print. Particular care is necessary to avoid injuring the negative with the nail in lifting back the print. The usual test of sufficient printing is when the shadows begin to bronze. At this time the highest lights should be either still quite clear or only just commencing to darken, so little that it will be removed in the subsequent operations and the white left pure. If in sun-printing the whites begin to darken before the shadows are sufficiently printed, it is a sign that the negative is thin and will require shade-printing. If in shade-printing the shadows are fully printed before the details in the high lights are got, it is an indication that sun-printing is needed; and if this defect appears in sun-printing, it is a hint that the negative in use will require paper less highly silvered.

Printing on Carbonate of Silver has been introduced in France, and has acquired considerable popularity. The paper is first sensitized with an alkaline carbonate, and then silvered on a *plain* silver solution (not ammonio-nitrate). Such paper keeps long after sensitizing, but requires thorough fuming before use, and to have oiled paper or oiled silk behind the back of the paper whilst printing, to retain the ammonia. It is asserted that the prints can be kept a month, if desired, before toning and fixing.

Printing under Ground Glass.—The effect produced upon the printing of a negative by interposing a plate of ground glass between the light and the negative is undoubtedly very curious. A great softening is produced; negatives which, printed in the ordinary way, give harsh and blocky prints, will sometimes, by this treatment, yield excellent results. The writer has seen soft, beautiful, and delicate prints got from negatives that must have been rejected, had they not been rendered useful by the application of this ingenious contrivance.

It is, of course, chiefly in portraiture that this device is useful. The writer, without ever having used it himself in landscape printing, has seen fine prints made by its help from hard negatives.

Printing under ground glass has somewhat the same effect as printing under tissue-paper in softening the image. To what has already been said under the head of "*Berlin Portraits*" (p. 194), it may be here added that some vary the effect by coating the ground side of the glass. This communicates a part of the grain of the glass to the print, producing somewhat the effect of an engraving.

Mezzotint Effects.—The method of obtaining these is explained at p. 194. It remains to mention here that the printing should be done in direct sunshine, and that it is found that the best results are got when the sun shines perpendicularly on the negative. M. de Constant suggests driving a nail perpendicularly into the face of the printing frame; when this nail *casts no shadow*, it is a proof that the frame is perpendicular to the sun's rays.

Portraits softened in these ways lose the harshness so conspicuous in some photographic work. They show less definition and boldness, but more harmony and softness. The improvement obtained in this way can never equal that resulting from retouching the negative; but, where this is not practised, it may often be useful.

§ 9.—The Pressure Frame.

The construction of the frame is of too great an importance not to receive a word of comment here. Two very serious troubles arise from bad pressure frames, breakage of negatives, and blurred prints. Pressure frames generally distribute the pressure very badly.

Take an ordinary piece of glass, the size of the frame, lay it in, put in the pads you commonly employ; take hold of the frame in both hands, the fingers on the back, the two thumbs resting on the glass near the centre. Press forcibly with the thumbs, until the glass moves back a little, and observe the amount of resistance. Next bring the thumbs up to one end, and press there; you will probably be surprised to find how much less the resistance is there, and, consequently, how unequal the pressure.

This inequality is a principal cause of the breakage of negatives in the frames, and is also a disadvantage to the print; for wherever the contact is not good, the sharpness of the print will be impaired, and this more so with shade-printing than printing in direct sunlight. The writer has already expressed his preference for the bar-frame, Fig. 12, p. 45.

Many operators are extremely careless as to what padding they use between the back of the frame and the print, considering that anything is good enough—mill-boards, old newspapers, etc. This is quite wrong; such inelastic substances cannot give good contact, and always endanger the negatives. Moreover, as the material for this purpose lasts indefinitely, it is worth while to provide it right, once for all.

The one thing that is better than anything else is piano-cloth. This is a soft, thick, green felt-cloth; when really good, it is about a quarter of an inch thick. It is expensive, but as a yard will make pads for twenty whole plate frames, the cost is not worthy of consideration when the safety given to the negatives is considered. A single thickness is sufficient, and a fine, elastic, equable pressure is obtained, which is invaluable. If by long use the felt has become flattened down, all that is necessary is to slightly wet it and let it dry.

The next best substance to this is probably a good thick flannel—woollen or cotton; the former is the more elastic. Whatever substance is used, should of course be of some non-actinic color.

The *Registering Pressure Frame*, for combination printing, has already been described. See Figs. 102 and 103, p. 183.

To accomplish the printing of as many frames as possible at once, a platform is set up outside of the windows and on the level of their sills. On this are placed slanting blocks, so that, when the frames rest upon them in rows, each frame will be inclined so as to face the sunlight as much as possible. At different times of day the frames are differently placed; when the sun is

low, they are kept more nearly perpendicular, and as the sun rises, they are placed more level. Much time is saved by having the frames kept well facing the sun.

A southeast exposure is the most desirable, though it is convenient to have at least one window with a westerly exposure for shade-printing. Some negatives will do best when not only printed in the shade, but also by having tissue-paper interposed. It is therefore convenient to have some frames kept permanently with tissue-paper stretched across the borders.

§ 10.—*Vignetting.*

When the print softens into a white border, it is called a vignette, and this mode of printing offers a beautiful variety. The negative is usually taken in precisely the same way as for ordinary printing, and the difference is made in the printing, though the effect can be very well produced once for all in the negative, if desired, as will be presently explained.

It should always be borne in mind that a vignette requires a light background. A sketchy effect (see section on Backgrounds) is very pleasing in vignettes.

Vignetting with a Frame.—This is the most usual way. The negative is placed in a frame on the face of which are springs which confine blocks of wood; in these blocks oval holes are cut, widening on the under side which is next the negative. On the upper side, farthest from the negative, tissue-paper is pasted to soften the light.

Vignetting frames are also made expressly. These commonly have pieces of tin set in front, provided with wire rings, over which the tissue-paper is to be pasted. For large negatives a convenient vignetting frame may be made by tacking a piece of stiff pasteboard upon the front of the frame. In this a hole is cut of the size desired, and this hole is covered with tissue-paper.

Vignetting glasses are sold in which a deep orange enamel is applied to the border, leaving an oval space in the middle, of clear glass; of course the color is shaded off at the edges of the oval. This glass is to be placed in the frame between the negative and the light.

Any one accustomed to photographic manipulations may prepare such glasses for himself, by photography. Cut a small piece

of oval hard wood, smaller than the part of the negative that is to be printed. Prepare a collodio-chloride or albumen plate for positive printing, lay the little block on it, and expose to diffuse light, turning the plate now and then. It is evident that the part of the plate that is covered by the block will be completely protected, and the portions round it will be shaded off. Or, by reversing the operation, and using a hole in a shield instead of a block, a reverse vignetting plate may be got, that is, a shaded centre in a transparent border. This may be used as a negative from which any number of vignetting plates may be prepared, either by contact printing or by development. The writer cannot recommend this as being a very easy method, but it is perfectly practicable, as he knows from having devised it and used it several years since. More lately, it has been proposed and advocated by others in print.

Vignetting with Cotton.—A piece of stiff mill-board is tacked to the front of the frame, in which an opening is cut considerably larger than the size of the portion of the negative which it is intended to print. White cotton-wool is pressed under the mill-board, and allowed to project beyond it until only that part of the negative is exposed which it is intended to print.

Vignetting with Paper.—In this case and in that immediately foregoing, the part of the negative that is to be printed is exposed uncovered. A piece of thin tissue-paper is cut with an opening

Fig. 122.

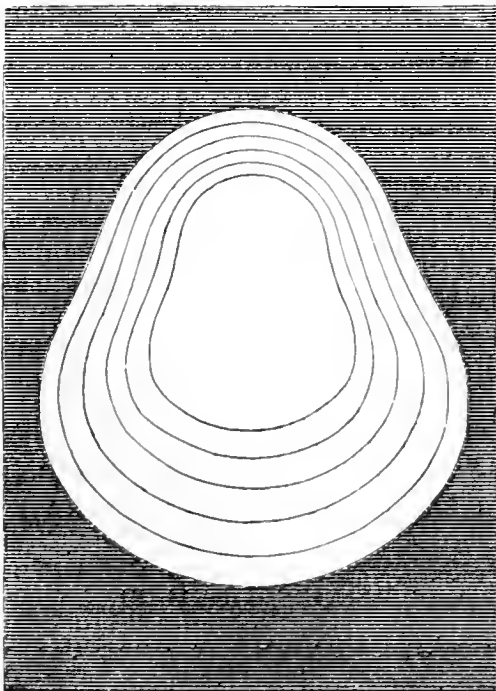

the size of the part of the negative that is to be fully printed; then another piece with the opening a little larger, and so on for a considerable number. These are pasted together and form a graduated shield, acting somewhat like the vignetting glass already described. By fastening this paper shield on the glass side of the negative and printing in the shade, the lines of the successive layers of paper can be concealed.

The sketch in the margin is taken from Mr. Blanchard, as showing a set of elegant and ap-

propriate curves suitable for card size (the size of the cut is necessarily smaller than that of a card portrait, but the curves are preserved of full size). Models of each of the diminishing openings are to be cut into card-board or thin tin; these once provided, any number of tissue vignettes may be made from them by using them to guide the point of the penknife in cutting the tissue-paper. The same photographer recommends, for other and more irregular shapes of vignettes, to attach to the back of the negative a piece of tracing paper, to run round lightly with the pencil the portion that is to print full tint, and again outside that, the portion to be quite white. This last is rendered opaque with any red or black color, and the space between the two lines where the softening is to be is graduated by rubbing in color with a common artists' stump.

Vignetting with a Lens.—This ingenious method is practised by some professional photographers to the exclusion of all others, and has the advantage of great rapidity. A burning-glass of some size (four to six inches in diameter) is set in a wide frame, or a piece of thin board. The negative is placed with silvered paper behind it in an ordinary frame, and the concentrated sunlight through the lens is allowed to fall upon the face. The lens is kept moving with a little circular motion, confining the light to the parts intended to be printed. In from ten seconds to half a minute the printing is finished. As the heat as well as the light is concentrated by the lens, it is necessary to have a thin piece of plate glass in the frame between the negative and sunlight, to prevent injury to the negative.

All these methods give excellent results. The last is evidently applicable chiefly to small heads, but the writer has seen beautiful vignetted cards made by it.

We next come to *vignetting on the negative*.

Vignetting by Development.—When the dark slide comes from the camera, the back is opened and an opaque shaded object of the shape and size of the vignette desired is laid on the back of the plate, which then, and without removing from the slide, is exposed for a few seconds to weak diffuse light. When the image is developed, of course all parts of the plate not protected by the opaque screen just described are developed black, in consequence of the second exposure. As the image is invisible at the time the opaque screen is applied, this last must of course

have been arranged in such a way by the image, as seen in the camera, as to make sure of the screen being correctly applied.

Vignetting by a Screen.—Another method has been proposed. A large white screen is to be prepared with an oval opening. This screen is to be placed between the camera and the sitter, who is thus seen through the oval opening. The screen being white, reproduces itself by opacity on the negative, and being so much nearer to the lens than the sitter as to be completely out of focus, it of course has an indistinct shaded border. There seems an objection to this plan, that it tends to throw so much white light into the lens. It has also been proposed, instead of a large standing screen, as just explained, to have a small one, only a few inches from the lens, and attached to the camera itself, capable also of being regulated in distance and position.

These last methods are rather exceptional; the use of the tissue-paper fastened over openings in wooden blocks or on metal rings, as above described, is almost universal.

§ 11.—**Toning.**

After the prints are removed from the frame, they may either be thrown directly into water or may first be trimmed; the latter method is found preferable by those who operate on a large scale.

The prints are washed by placing them one by one in a pan of water, where they all lie for a short time. This water is to be repeatedly changed, and of course is to be saved, at least the two or three first washings. It is rich in silver, which is to be thrown down as chloride by common salt. A neglect to wash the prints sufficiently is liable to produce two evils, a yellowing of the whites in the toning bath and a difficulty in toning; these troubles may come separately or together. This is the case especially with the toning baths now commonly in use. Those toning baths into the composition of which sulphocyanide of ammonium or hyposulphite of sodium enters, do not present this difficulty, and although it is best to wash the prints before toning in them, it is not absolutely necessary, nor need it be so carefully done.

The principle of toning is the substitution of gold for silver in the print. If a washed print be simply thrown into a dilute solution of chloride of gold, it will tone, but the acidity of the solution will lead to a great reduction in the strength of the picture.

It is, therefore, needful in some way to neutralize the acidity, which may be done with carbonate of sodium, carbonate of calcium, or certain salts that have an alkaline reaction, such as phosphate of sodium, acetate of sodium, or borate of sodium, each of which substances forms the foundation of various toning formulæ. The explanation of their action is this: part of the alkali present becomes converted into chloride, which enters into combination with the chloride of gold, forming, for example, in the case of soda, chloraurate of sodium. The acid previously in combination with the alkali is set free, but being in all the above cases a weak acid (carbonic, phosphoric, acetic, boracic), is without injurious influence on the bath. In fact, other combinations of alkali with weak acids may be substituted. The writer has obtained excellent results with *benzoate of potassium*, which he some time since proposed for making the toning bath with, and which has been very favorably reported on by others. *Tungstate of sodium* has also been used with good effect. Certain acids have a reducing effect upon salts of gold; oxalates and formiates cannot be used for this reason. Citrate of sodium has been used and was highly recommended some years back, but is now little employed.

VARIOUS TONING FORMULÆ.

Alkaline Carbonate Toning Bath.—To make this very popular bath, the gold solution is simply rendered alkaline with bicarbonate of sodium; the following proportions may be used:—

Water	32 ounces.
Chloride of gold	1 to 3 grains.
Bicarbonate of sodium	5 grains.

Mix twenty-four hours before using.

The gold gradually tends to precipitate from this bath, whereby it becomes inactive. Some operators, after using, add just enough hydrochloric acid to make it turn litmus-paper red, and then, before using again, add enough bicarbonate of sodium to cause it to turn red litmus-paper blue. In this way it keeps indefinitely.

Calcio-chloride Toning Bath.—A solution of chloride of gold is made, one grain to each ounce of water, and a couple of grains of precipitated chalk to each ounce are added and shaken; next day it is ready for use, diluting each ounce with ten to twenty of water.

This bath tones much like the preceding; gives brown, purple, black, or black tones, and, by overtoning, blue. Succeeds best with paper sensitized on neutral baths.

Acetate of Sodium Toning Baths.

Chloride of gold	10 grains.
Water	80 ounces.
Acetate of sodium	1 ounce.

This bath differs considerably from the foregoing. It will not give black tones, no matter how prolonged its action, but gives splendid warm purple shades that cannot be excelled and cannot be equalled by the common carbonate of sodium bath. If wanted for use in the shortest time, it should be mixed with warm water and let to stand.

Benzoate Toning Bath.

Bicarbonate of sodium	5 grains.
Benzoic acid	10 “
Chloride of gold	1 grain.
Water	10 ounces.

Gives warm tones similar to the preceding. This bath, originally proposed by myself, works satisfactorily and keeps very well. It acts, perhaps, a little more uniformly than the preceding. Instead of the benzoic acid and bicarb. sodium, an alkaline benzoate may be employed.

Although any of these, or of the following, can be used for almost any purpose, yet certain baths will always have uses for which they are specially adapted. Landscapes should be toned only with the acetate or the benzoate bath. Small heads, as, for example, card portraits, are best toned with the carbonate bath. Reproductions of engravings, needing a pure black, may be toned with the carbonate, but still better with the chloride of lime bath, to be presently described.

The following special formulæ have been adopted and published by experienced and successful photographers:—

Mr. Notman's Formula.

Water	210 ounces.
Acetate of sodium	1 ounce.
Bicarbonate of sodium	$\frac{3}{4}$ “
Nitrate of uranium	16 grains.
Chloride of gold	12 “

Keep twenty-four hours before using. When about to use, add eight grains more gold, and continue to add according to the quantity of prints toned.¹

Dr. Shepard's Formula.

Chloride of gold	4 grains.
Water	1 ounce.
Neutralize with powdered chalk.	
Chloride of lime	4 grains.

Let stand a few hours; pour the whole, including sediment, into twenty ounces water; shake well; let stand over night, and pour off the clear part.

After use, return to bottle, shake up, add gold in proportion to prints toned, and a grain of chloride of lime for every grain of chloride of gold, or thereabouts, keeping the bath smelling faintly but distinctly of chlorine.²

This bath gives a variety of good shades, up to full black. In fact, a pure black seems to be obtained more easily with a chloride of lime bath like this, than with the other formulæ. The bath keeps in order for many months, always ready for use.

Dr. Liesegang's Formula.

A. Water	50 ounces.
Fused acetate of sodium	1 ounce.
Phosphate of sodium	45 grains.
Chloride of lime	15 "
B. Water	50 ounces.
Chloride of gold and potassium	15 grains.

These two solutions are to be kept separate and mixed in equal bulks as wanted, immediately before use.

It seems useless to farther multiply formulæ, but it may be remarked here that, as the function of the substance added to the gold solution is to neutralize it, and prevent the corrosive action of the chloride of gold in its primitive state, it follows that *alkalies combined with almost any weak acid* are likely to give good toning baths, of which an almost endless variety may be composed, differing considerably in the tones which they impart. In addition to the baths given here, alkaline *tungstates* and *borates* are occasionally used and liked by operators. Those who desire to experiment can take the second formula and substitute for the acetate of sodium such other salts as they may like to test.

Slow toning gives the richest and finest effects. The work may be expedited by heating or by using stronger baths, but the results are not so fine. When a bath refuses to tone, a little more chloride of gold may be added to start the action.

§ 12.—Toning and Fixing Baths.

It remains to speak of certain baths which effect at once the toning and fixing. These are made either with hyposulphite of sodium or sulphocyanide of ammonium.

Hyposulphite Fixing and Toning Bath.—If two ounces of hyposulphite of sodium be dissolved in eight ounces of hot water, a grain of chloride of gold previously neutralized with carbonate of sodium (ammonia or phosphate of sodium will not answer) be added *after the hyposulphite has dissolved and been stirred up*, we obtain a mixture which, after half an hour's standing, is in condition to fix a print, at the same time toning it to a rich purple black.

Great fault has been found with this mode of toning, and it is certainly less safe than the foregoing. If used a few hours after mixing, and if a very moderate number of prints be fixed in it, they are as permanent as those treated separately. But, after standing, or if more than a very moderate number of prints be fixed in it, these are sulphur-toned, and speedily fade and turn yellow.

Good tones are more easily got by separate toning than by this bath, which often gives coppery tones when it is difficult to find a reason why.

Sulphocyanide Toning and Fixing Bath.—The writer believes that he was the first to show that a toning and fixing bath could be made with a sulphocyanide and chloride of gold. His experiments were made in 1865, and are referred to in the *British Journal* for 1866, p. 460 and p. 508. A solution of sulphocyanide of ammonium mixed with chloride of gold is quite free from the objection of fading. But the prints must be left some time in a second and fresh bath of sulphocyanide, otherwise a silver compound remains in the paper, and eventually darkens.

To prepare this bath, chloride of gold is to be precipitated with a very few drops of ammonia, and redissolved with sulphocyanide of ammonium. This rose-colored solution, if used fresh, stains the lights rose-color. But if kept twenty-four hours, it becomes colorless, and then no longer stains the lights. Dr. Liesegang

finds the addition of a little *sal ammoniac* very advantageous for preserving the whites clear.

When toning baths lose their toning properties, there frequently remains gold in them which has passed to an inactive state. This can be thrown down by making the bath acid with a little hydrochloric acid, and then adding a few drops of solution of sulphate of iron. The gold falls immediately as a brown powder, which may be collected on a filter and preserved.

§ 13.—Fixing the Prints.

After the toning is finished, the print is passed through clean (but not necessarily distilled) water, and is thrown into the fixing bath.

Hyposulphite of sodium	1 pound.
Water	4 to 5 quarts.

Using it a little stronger in winter than in summer. A print ought to be completely freed in ten to twenty minutes. Too long a time in the fixing bath will diminish its beauty.

Until lately, the substance exclusively used for fixing positives on paper has been hyposulphite of sodium. Within a year or two sulphocyanide of ammonium has been proposed as a substitute, on the ground that the prints were thereby secured from the injurious action of partly used hyposulphite, which causes fading.

When either chloride or nitrate of silver is added to a solution of hyposulphite of sodium, decomposition takes place, with formation of tetrathionate of sodium,¹ an unstable substance which readily undergoes farther decomposition. Tetrathionate of sodium will itself tone a print very beautifully, entirely without the aid of gold; its toning action seems to depend upon the formation of sulphide of silver, an intensely black substance, so that this process may be likened to some extent to the blackening of a collodion picture with alkaline sulphide, with this difference, that the action of alkaline sulphide is far more powerful and extends to chloride and iodide of silver, which it blackens readily and intensely. Tetrathionate of sodium, or rather the hyposulphite bath containing this substance, will not do this, nor will it

¹ Tetrathionic acid (S_4O_5) differs from hyposulphurous acid (S_2O_2) in having one-fifth less oxygen.

attack the albuminate of silver which remains to some extent all through the substance of the picture. A sulphur toning bath spares, therefore, the whites of the albumen print, which a solution of alkaline sulphide would turn brown.

The tendency to fade seems to be distinct from this production of sulphide, although it mostly accompanies it. The mere production of sulphide of silver could not cause fading, for sulphide of silver is a very permanent substance. This we see abundantly proved in the case of negatives which have been treated first with solution of iodine and then with a bath of sulphide of potassium, and which have no disposition to fade, even by long keeping. The addition of three or four grains of bicarbonate of sodium to the ounce of fixing bath, is useful as checking somewhat the tendency to produce unstable prints.

Generally speaking, the print tends to gain in permanence by a prolongation of the action; some which the writer left for over an hour in a joint toning and fixing bath exhibited remarkable resistance to the destructive agencies of various tests which he applied to them. But the loss of brightness by long immersion indisposes photographers to permit it.

No more important advice can be given to the photographer than *Do not spare the hyposulphite*. Even a fresh bath should not be used for too many prints, and a bath which has stood over night after using, should be *unhesitatingly* rejected, because the decomposition goes steadily on, and such a bath is in much worse condition the next day than it was at the end of the day of use.

It is always difficult to induce photographers to act upon correct principle as respects the toning bath, not merely on account of the expense of the gold solution (it requires a better toned print to withstand the action of the fixing bath when the latter is fresh and in right condition for the permanency of the print), but because it is easier to work with a decomposed fixing bath; so much so, that ten years ago it was even recommended to start decomposition in the bath by substances purposely added. But the photographer who really desires to do justice to his work will not allow himself to be swayed by such considerations, and may be assured that with a little care he will obtain admirable tones that will resist the fresh hyposulphite and give prints that will not disgrace him by turning yellow and fading out.

§ 14.—Washing.

The subject of washing is one that demands the greatest care on the part of the photographer, and there is an almost positive certainty that unless it be done systematically and thoroughly, the prints, however carefully managed in other respects, will rapidly fade. To work thoroughly, the water must be used abundantly, and must be continually changed.

If prints be thrown into a tank, and a stream of running water be made to flow into it for several hours, a few prints may be satisfactorily washed. But if the number be large, they will interfere with each other, and the washing will be more or less imperfect.

The simplest contrivance for obviating this difficulty is to have a plug in the bottom of the tank which can be removed from time to time and the tank emptied. Both the time of washing and the quantity of water necessary are in this way very much diminished, but care is necessary that the prints be not drawn into the orifice.

To obviate the necessity of attending to the washing and removing and replacing the plug, a siphon may be adapted to the tank, which will come into operation as soon as the water reaches a given height (see Fig. 123). The siphon pipe passes under and through the bottom. The opening in the bottom which communicates with this pipe is to be covered with a strainer. Or, what is much better still, is a plan adopted by the writer: a ledge is made all round the sides at a height about an inch above the bottom, and on this rests a sheet of metal pierced with a great many holes about a quarter of an inch in diameter. The prints, as the water drains away, rest on this plate and get a very thorough draining away of the wash-water. There is an additional advantage in this arrangement, that it is impossible for prints to lie over and block

Fig. 123.

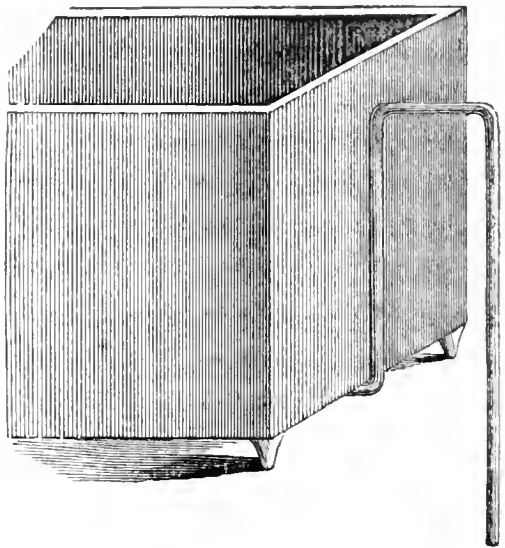

up the exit pipe. The sheet should be made of sheet tin, varnished, and not of zinc.

Considerable care must be taken in the arrangement of the siphon to make it do its work regularly. To empty the tank, the water must of course run out faster than it is supplied; the diameter of the siphon must therefore be larger than that of the supply pipe, especially as the water comes from the street mains under a stronger pressure than it runs off, and therefore it is supplied faster than the mere proportion between the pipes. This larger size of the siphon introduces this difficulty, that the water tends simply to drain off through it, instead of starting the action of the siphon and so emptying the tank. This difficulty the writer finds may be lessened by lengthening the lower limb of the siphon, and contracting it a little at the opening of the lower end.

The stream of water should, in all cases, be thrown obliquely against the side of the tank; this gives a rotary motion to the whole body of water and keeps the prints constantly moving, a most important consideration, and which should never be neglected. The flow of water through the siphon will be regulated as to rapidity by the difference between the length of its legs. The greater length given to the long leg the more rapid the flow of the water, and the less danger of draining off without starting the siphon.

Other and more complicated plans for supplying the water have been proposed, such as carrying a pipe round the inside top edge, and piercing it with holes, so as to sprinkle the surface of the water with small jets. But unless these are so contrived as to send slanting streams, and so keep up a rotary motion, a great advantage is lost.

An ingenious arrangement consists in dividing the tank into two parts by a compartment, underneath which, and under the bottom of the box, is placed a fulcrum on which the tank balances backward and forward with a see-saw motion. The compartment that is uppermost receives the stream of water till it reaches a certain height; it then rocks over, and the other side receives the water. Meantime the first side is emptying out, and, when empty, rises again and again fills. In a narrow compartment or drawer under the tank, and attached to it, a quantity of bullets are placed loose. These roll from end to end, and by their weight prevent the end that is lowest from rising too soon.

In whatever way the photographer elects to wash his prints, he must satisfy himself that the work is done effectually. The mortification which must be experienced by those who have distributed handsome-looking prints, at finding them turn yellow and fade, cannot be otherwise than very great, and nothing has acted upon photography so unfavorably as the universally recognized uncertainty as to the durability of its most attractive productions.

There are several ways of testing whether hyposulphite is completely washed out. Two simple but not very accurate methods are the following:—

1. Touch the white of the print with a little weak solution of nitrate of silver. If a brownish mark is made, it is certain that the print is very imperfectly washed.

2. Touch the white of the print with a little *very* dilute solution of iodine in alcohol. A blue mark indicates that the print is pretty nearly free from hyposulphite. Before using this test, it should be ascertained that the particular paper used is sized with starch, or at least has some starch in the sizing, which strikes a blue tint with iodine when no hyposulphite is present. To fix this point, touch a piece of the paper that has not been sensitized with a little very weak solution of iodine in alcohol, on the back. If no blue stain is produced there is no starch in the sizing, and this test cannot be used.

3. By far the best test is the following: Take a clean beaker, or even a two-ounce vial, provide a small piece of white blotting-paper, on which make some irregular marks with a glass rod dipped in weak solution of acetate of lead.

Fill the beaker or vial nearly full of water, add a few drops of sulphuric acid, and mix. Then put in a part of the print to be tested, several square inches at least, and drop in ten or twenty grains of granulated zinc, and immediately cover the mouth with the blotting-paper marked with acetate of lead, which must be still moist. Leave the whole for ten or twenty minutes. If the markings turn brown, it is a proof of insufficient washing. Prints that will stand this test may be considered as thoroughly washed, which cannot be said of (1) and (2), which are less exact.

It is necessary to be sure of the purity of the sulphuric acid and zinc employed, and the best way to accomplish this is to try the experiment *à blanc*, that is, go through it *without* the print to be tested. If then the markings become brown, it is a proof that

the materials are impure. This preliminary trial entails very little trouble, as one may immediately afterwards proceed to test the print, adding it to the other materials, and, if necessary, a few drops more acid to keep up a very gentle escape of gas.

Where sulphocyanide of ammonium is used as a fixing agent, it is probable that a materially less amount of washing is sufficient. But care must be taken that the fixing has been effectual. This may be ascertained by covering one-half of a print and exposing the other half to a bright sunlight for three or four hours, or, better, a day. If any difference in the purity of the whites is perceptible in the two halves, the fixing has been insufficient.

§ 15.—Finishing the Print.

The fixed and washed print will next require to be trimmed and mounted.

When very large quantities of prints are trimmed, machines are made that cut them out of the required shape at a single blow. This method is peculiarly suited to portraits, especially card portraits. Landscape prints require more attention, and the trimming can often be so regulated as to improve the general effect.

An extremely convenient arrangement is to procure a thick plate of glass with its sides exactly at right angles to each other, and to rule on it with a diamond a number of lines parallel to the sides. Then resting the plate on the print, some one of these lines is kept parallel with a vertical or horizontal line of a building, or with the line of the horizon itself. Then a sharp blade is run round the edges.

Fig. 124.

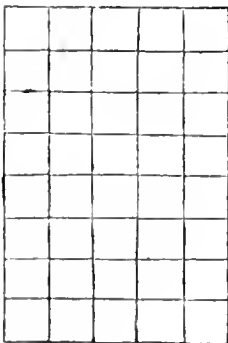

It is convenient to have one end of the plate dome-shaped. The edges should bevel a little, receding as they rise from the print; the ruling should be on the *under* side.¹

Some operators use brass frames. These are very objectionable, as fine fragments are chopped off and ground into the paper,

¹ These plates are made and for sale in London, but, apparently, not here. Mr. B. Shoemaker, of this city, has made one for the author, of 8×10, a larger size than is kept in London. Probably when they are better known here, they will be kept by dealers.

eventually making stains. Steel edges to glass plates are excellent, but brass edges to glass plates are to be condemned.

The trimmed print is next to be attached to the mount with some adhesive substance. Glue is undoubtedly the best, but not the least troublesome, and is therefore less used than paste and gum.

Whatever is used should be applied freely, and a few minutes given to swell, otherwise the print cannot be applied smoothly and evenly to the mount. Whatever adhesive material is used, should be freshly made. Sour paste is very objectionable.

Many amateurs like to paste their prints into scrap-books instead of mounting on cards, attaching them to the leaf by the four corners only. A good deal of annoyance is often caused by the cockling up either of the print, the leaf, or both. The writer finds that this trouble can be *perfectly* avoided as follows:—

Place some powdered gum-arabic in a wide-mouthed vial with a long thick cork. Moisten the bottom of the cork with the tongue, place it in the bottle, reverse it, and some powder will adhere; moisten again slightly, and gently rub the under corners of the print with the cork, transferring thus a very thick mucilage, which dries almost instantly, and without cockling. No one who uses this method will ever use any other. It has, beside its freedom from cockling, the advantage of being always ready, and yet always affording a perfectly fresh material, free from danger of sourness, and certain not to black the corners of the print.

Too little attention is paid to the quality of the pasteboard used for mounting. If this contain hyposulphite of sodium, used as “antichlor” by many papermakers, the eventual destruction of the print is almost certain, as in damp weather enough moisture penetrates to transfer the hyposulphite to the print. It has been affirmed that three-fourths of all the mounts in the market give indications of hyposulphite when tested carefully.

It is therefore no small protection to the print to have a lithographic “tint” printed on the board for mounting, and extending a short distance beyond the print all round. In this way the transfer of soluble ingredients from the mount to the print is rendered well-nigh impossible. As various adhesive preparations adhere much less well to thick “photographic tints” than to ordinary paper, it is generally necessary to use good glue, otherwise the prints readily peel off.

In damp weather the drying of the adhesive application between the two hard surfaces proceeds slowly, and care must be taken *not to pile up the prints too soon*, or the evaporation may be checked, and the paste or other material may mould, and immediately stain the prints. Hundreds are sometimes lost in this way before the danger is perceived.

Rolling.—Prints, after mounting, are always rolled, usually in powerful presses between steel surfaces. This forces together the fibres of the paper, gives a hard, fine surface, darkens the print a little, and improves its appearance materially. It is best done just before the print is dry after mounting. The steel surfaces must be kept bright, which is often troublesome. *Nickel plating* greatly diminishes the trouble of preserving a high surface.

Encaustic paste is prepared by dissolving white wax in essential oil of lavender, or any other volatile solvent, to a pasty consistency. This mixture, well rubbed into a print with a tuft of flannel, adds considerably to the transparency of the shadows, and, in many cases, decidedly improves the picture. It has also a favorable influence upon the durability of the print. Salomon, whose prints are remarkably fine, gives the following formula:—

Pure virgin wax	5 ounces.
Gum elemi	44 grains.
Benzole	2 ounces.
Essence of lavender	3 “
Oil of spike	66 drops.

Grüne boils equal parts of white wax and castile soap in an earthen vessel with a little water, enough to make a soft paste.

§ 16.—Permanence of Silver Prints.

Great discredit has been thrown upon photography by the fading of silver prints, an effect which the author believes to have resulted from negligence in washing. A well washed and toned print is, according to his experience, very durable. Of gold-toned prints made by the writer of this manual not a single one has faded or altered in any respect.

The writer believes that in very many cases of fading, especially of views made for sale, there has been no gold toning at all, but simply a sulphur toning. With albumenized paper this toning is sure in the long run to decolorize very much, though

some specimens on plain paper, executed by him many years ago, are still as good and as pure black as the day they were finished.

The different modes of gold toning seem all to yield results equal in respect of permanence. Developed prints, although gold-toned with equal care, are less permanent, according to careful and extended experiments made by the writer, than sun-prints. Of these last, the strongest seem to be those that have been over-printed enough to bear a very full time (twenty minutes or thereabouts) in a strong fresh hyposulphite bath.

CHAPTER XIV.

FAILURES IN PHOTOGRAPHIC OPERATIONS.

THE beginner in photography will be very apt to find that, after proceeding reasonably well for a time, his success suddenly terminates for some reason quite undiscoverable to him. He appears to be proceeding exactly as before, yet he cannot get the same results. A very simple and useful course will be to change each of his materials in succession, collodion, bath, and developer, and so endeavor to detect the proximate source of the trouble. This plan does not always, however, succeed, for the new material substituted may have precisely the same fault as the old; it may not be in any respect bad or impure, but may be simply unsuitable to the other materials with which it is employed.

Not only the beginner, but even the experienced photographer, will occasionally find that things go wrong; no one can claim entire immunity from photographic troubles. For these reasons the writer has endeavored to make this chapter a very complete one, believing that it will be very frequently referred to, and with advantage. He has collected the information here given partly from personal experience, but also very largely from other sources in various languages. For convenience of reference, it has been carefully classified under different heads:—

I. FAILURES COMMON TO NEGATIVES, AMBROTYPES, AND FERROTYPES.

- Sec. 1. Fogging and Veiling. *See page 302.*
 " 2. Thinness of Film. *Page 310.*
 " 3. Irregularity of Film, Crapy and Structural Lines, Granularity, Warty Lumps, etc. *Page 310.*
 " 4. Transparent Mottling at Corners. *Page 312.*
 " 5. Defects in the Image. *Page 313.*
 " 6. Splitting and Slipping of the Film. *Page 316.*
 " 7. Want of Sharpness. *Page 317.*
 " 8. Streaks. *Page 318.*
 " 9. Transparent Spots and Pinholes. *Page 321.*
 " 10. Opaque Spots, Comets, etc. *Page 324.*
 " 11. Lines. *Page 326.*
 " 12. Stains and Surface Markings. *Page 327.*
 " 13. Feathery Markings: Imperfect Fixing. *Page 330.*
 " 14. Faults in Varnishing. *Page 330.*
 " 15. Miscellaneous. *Page 333.*

II. FAILURES BELONGING ESPECIALLY TO NEGATIVES. *Page 334.*

III. FAILURES BELONGING ESPECIALLY TO AMBROTYPES AND FERROTYPES. *Page 335.*

IV. FAILURES BELONGING ESPECIALLY TO PAPER DEVELOPMENT. *Page 336.*

V. SILVER PRINTING.

1. *Failures Common to Glass and Paper Work.* *Page 336.*
2. *Failures Peculiar to Silver Printing on Paper.* *Page 338.*
3. *Failures Peculiar to Collodio-Chloride Printing.* *Page 342.*

I. FAILURES COMMON TO NEGATIVES, AMBROTYPES, AND FERROTYPES.

§ 1.—Fogging.

Fogging is a trouble that affects different operators very variously: some are very frequently, others almost never affected by it. The learner may expect to be frequently troubled; the experienced operator will have learned how to avoid it, except,

perhaps, when he works under unusual conditions, or with chemicals different from those which he habitually employs.

Before proceeding to the particular sources of fogging, some observations of a general nature may advantageously be made.

General Remarks.—When a case of fogging presents itself, a careful study of the appearance of the plate will often afford a clue to the source of the trouble.

A fogged plate may present a uniform sheet of blank fog all over, without a trace of a picture. Or an image may come out with more or less strength, but, after showing itself, may presently become covered with a dense deposit of silver. Or, finally, the fogging may be very slight, leaving all details of the image perfectly visible, but ruining it by veiling the deep shadows sufficiently to prevent them printing to a full rich black.

The above various cases are alike in this, that the action of the fogging is *uniform* all over the plate. We, therefore, presume that the trouble lies either in the chemicals, the light, or the atmosphere of the dark room, and, if we cannot get rid of the evil by the addition of a little iodine to the collodion, we must commence a series of systematic trials (see p. 306), to detect the source of the trouble. We do not, however, in the above case, suspect the camera. For, if the camera leaks light, the effect of that light is invariably partial and irregular. The unequal contraction and expansion of the wood round the flange, into which the lenses are screwed, will often produce a crack; this will give a mass of fog somewhat denser in the middle, and shading off towards the ends of the plate. A hole in the bellows body will produce an irregular mass of fog on some part of the plate on which the light falls. If the dark slide does not fit tight, the fogging will mostly be at one end of the plate. A crack in the shutter will produce a bar of fog lengthwise of the plate, and shading off on both its sides. Cracks in the woodwork will send in fan-like masses of light, and so on. These appearances will aid at once in the detection of the cause of the troubles (see also, beyond, "White Light," p. 306).

Another very valuable distinction is drawn as follows:—

A *superficial fogging*, one that rests *on* the film and not *in* it, and can be rubbed off with the finger, is always attributable to the chemicals, never to exposure to white light, which last always produces an action in the interior of the film.

Therefore, if the fogging be internal and not superficial, it is

most probably owing to intrusion of light; this cannot be affirmed with entire positiveness, but is the most likely cause, for faults in the bath, collodion, etc., most generally give rise to superficial fogging. That is, fog from chemicals is *generally* superficial; superficial fog is *always* from chemicals.

1. *Chemicals in Fault.*—Generally speaking, when fog shows itself, and when the presence of white light is not suspected, the first thing done is to treat the bath.

But, in all such cases, the first step should be invariably to try another collodion, or to add a little tincture of iodine to that in use. Iodine tends to make the bath slightly acid. Therefore, the addition of acid to the bath, or iodine to the collodion, is, in each case, a step in a somewhat similar direction. And it would at first seem more correct to add the acid to the bath, as that brings the bath at once to the requisite point of acidity, and stops there, whereas, by adding iodine to the collodion, every plate tends to render the bath more acid.

But, in practice, it is found that the results of the two treatments are very different. Sometimes a very little iodine will effect a cure when acid seems to have no effect. For example, the writer has seen a bath made of fused nitrate of silver absolutely refuse to give a clean picture, even when acidified beyond what is proper, and yet work excellently by adding a very little iodine to the collodion—a collodion which was not new, but had worked perfectly a month before, in cooler weather, with a nearly neutral bath.

When a neutral nitrate has been used, acidulation should not be carried beyond one drop of nitric acid or twenty-five drops of No. 8 acetic acid to every fifteen or twenty ounces of bath, and this much is only allowable when the nitrate of silver was free from acid. When the acidifying has reached this point, if the picture is not clean, the remedy is most certainly needed in the collodion. And it must never be forgotten that these treatments with acid or with iodine are but necessary evils, and that the more nearly neutral the bath and collodion the more rapid will be the work. There appears to be no doubt that excess of nitric acid in the bath may cause fogging.

The bath, however, may have been alkaline, and may therefore need neutralizing and acidifying. This will be ascertained by introducing a piece of red litmus-paper. Alkalinity may arise from having introduced an alkali intentionally, especially if am-

monia have been added, previous to sunning. Bicarbonate of sodium renders a bath rather neutral than alkaline, and is the only substance that should ever be employed for removing an excess of acidity. Or alkali may have been carelessly introduced, when glasses cleaned with caustic soda or other alkali have been insufficiently washed before collodionizing.

The use of fused nitrate of silver, that has been kept too long in a state of fusion, or heated to too high a temperature, may tend to produce fog. Remedy: add very dilute nitric acid very cautiously, or try an older collodion.

An old bath, highly charged with impurities, may lead to fogging. As a palliative, add bicarbonate of sodium till a permanent precipitate falls, and then expose for several days to the sun. Filter, and acidify if necessary.

Sometimes an old bath will lead to fogging, not by reason of impurities, but simply by having become too weak by mere exhaustion of the silver. This will be more apt to happen with baths whose evaporation is checked by being kept covered. Remedy: add crystals or fused nitrate of silver.

Or the *collodion* may be in fault. A very new collodion, especially one containing little or no alkaline salt, but chiefly cadmium salt, particularly if used with a nearly neutral bath, will sometimes refuse to give clean, bright pictures. (See also p. 136.)

In this case, especially if the collodion be very pale, it is well to add to it a little tincture of iodine, and so apply the remedy to it rather than to the bath. Or the admixture of a little old (but not too old) and more highly colored collodion will be found useful.

The *developer* may be in fault. If, when thrown upon the plate, it becomes almost immediately muddy, more acetic acid is wanted. Or, a developer that has hitherto worked well, may cease to do so in consequence of a change of weather and temperature.

It has been affirmed that *excess of acetic acid* may produce fogging.

If copper be used in the developer (sulphate of copper, blue vitriol), and the plate have been left in the bath for a time insufficient to convert all the soluble iodides into iodide of silver, *brown fog* may be produced by the formation of iodide of copper in the film.

Old specimens of pyrogallic acid used in developing or redeveloping, have been known to produce *blue fogging*.

2. The *vessels may be in fault*. India-rubber or vulcanite bath, or even dippers, may lead to fogging, and are more likely to when new than old. In work in the house, they should never be used. Even for work in the field, the writer advises a glass bath with a case and screw cover. But if weight is very important, and a rubber bath is to be used, it should, if new, be put aside for twenty-four hours with a strong solution of caustic alkali. The "concentrated lye," sold in sheet-iron boxes, is very good for this purpose, and may be dissolved in eight or ten times its weight of water. In the case of an old bath, it should be scrubbed out with a sponge tied to a stick between each using.

3. The *water may be in fault*. It is said that cases of fogging have been traced to this source, but the writer has never experienced it. The sorts of water said to cause it are—water containing iron; water containing much lime; rain-water collected off of dirty roofs, or water from wells into which any decaying matter penetrates, or any foul drainage.

4. *White light* will, of course, cause fogging. As already said, a careful examination of the appearance of the plate will generally indicate whether light has been admitted into the dark room, or has made its way into the camera, because, in the first case, its action extends uniformly over the whole plate, in the other it does not, but mostly appears in bars, fans, brushes, or long slanting rays, the positions of which will always aid in tracing out the cause, remembering that the more indistinct the boundary of the fog the farther is probably the opening or leak from the plate.

A few *systematic trials* will always force out the source of the fault.

Develop a plate without exposure and without removing it from the dark room. If no tendency to fog appears, the fault was clearly in the camera or the dark slide. Then sensitize a plate and carry it into the glass room in its dark slide. Leave it a few minutes and develop it again without having exposed it or withdrawn the shutter. If it then fogs, the leak is in the dark slide; if not, then it must be in the camera.

Let us, on the other hand, suppose that the plate fogged, when developed, without having been removed at all from the dark room. Then the fault is, either that white light gets into the dark room, or the chemicals are in fault.

A simple way of deciding this is to try a plate at night. Use only a candle or lamp, well protected with yellow or green glass. Sensitize a plate, lay it on a dark object, put a worthless negative over it, and carry it into another room, in which is a gaslight, turned on. Hold the plate a foot from the burner for fifteen seconds, taking care that the back is perfectly protected. Then carry and develop, by the light of a lamp or candle, behind yellow glass. If a clean picture comes out, it is a proof that white light gets into the dark room in daytime. If it fogs still, when tried thus, the chemicals are wrong, and must be changed, one after another, until the wrong one is detected.

This simple but systematic and exhaustive search will invariably lead the operator straight to the source of his trouble.

If the foregoing examination shows the fault to be with the camera, it must be carefully overhauled. Carelessly made cameras are quite worthless, and a great many such are exposed for sale. The writer dislikes walnut, although this wood is so great a favorite, because it cracks so much, and prefers mahogany, and next to it, cherry. Look, therefore, carefully for cracks. Examine if the shutter works close in the dark slide. Notice if a hole has been worn into the bellows body. But the commonest place to crack is the camera front, which often splits at the screws that fasten the flange in. When a crack once appears, do not trust to filling it up, but get a new front. A crack slowly widens, and so leaves a space between the edges and the filling. A crack may, however, be neatly mended by a good workman. The front is cut half-way through at the crack, for half an inch each side, and a piece set in. Then if the crack widens, it can do no harm, and another crack is not likely ever to form, as the tension that caused it has been relieved.

When a camera is used in the open air, it must invariably be covered with a thick cloth. Strong light, especially direct sunlight, will make its way through almost any camera, unless so protected.

5. *Sunlight falling directly upon the lens* may cause fogging, though this result does not necessarily follow.

6. *Atmospheric Causes.*—The sources of fogging may depend upon impurities in the air. These may be of several sorts.

A. *Chemical.*—Fumes of various sorts may cause fogging. Ammonia is especially to be avoided. See that the ammonia

bottle has a well-fitting glass stopper—not a cork. Sulphuretted hydrogen, arising from exposure of solutions of sulphide of potassium, or of Schlippe's salt, is even worse.

B. *Certain organic substances* have a tendency to cause fogging. The vapor of turpentine and of fresh paint. The smell of kerosene lamps in the dark room does not seem to be hurtful, as might be supposed.

C. *Foulness in the air* is liable to cause fogging. Emanations from drains, cesspools, and the like, or any putrefying or decaying organic matter. Emanations from stables are always ammoniacal, and tend to fogging. It should be borne in mind that immunity from these sources at one time, is no proof that they may not be acting at another. *Dampness* acts very remarkably as a vehicle for odors, and emanations may rise in wet weather so as to cause fogging, when they would not at other times. Independently of this, the *state of the barometer* controls currents and movements of air remarkably. When the barometer is rising, a room will be supplied with air from channels quite different from those that act when the barometer is falling. Drafts of chimneys are always worse with a rising barometer. Whether *carbonic oxide*, the gas which flues are intended to carry away from fires, will cause fogging, the writer cannot state, but no one is justified in permitting this most dangerous gas to escape into apartments by defective flues. Its danger is not greatest when it asphyxiates, for then the evil is noticed in time, and remedies are applied. But if inhaled continually in small quantities, it causes diseases of the brain and spine. Leakage of illuminating gas may cause fogging.

7. *Errors of Manipulation.*—Under this head the following are to be classed:—

a. *Plate left too long in the bath.* This, especially in warm weather, is a fruitful cause of foggy plates. When the plate is perfectly free from oiliness, it is ready for removal. The *sensitiveness* increases by leaving in for a full time; the *brightness* and *cleanness* are greatest when the plate is taken out as soon as the oily lines are gone. In the latter case, undecomposed bromide remains in the film, diminishes sensibility, but checks veiling and fogging.

b. *Too long a development*, rendered necessary by too short an exposure.

c. *Neglect to add acid* to the developer or the redeveloper.

d. *Insufficient washing* off of the developer, so that enough remains to act.

e. *Considerable over-exposure with a large stop* will produce fogging, or rather an appearance closely resembling the effect of fog.

f. *Re-dipping the plate into the negative bath* before development is very apt to cause stains and fog, especially with a bath not in first-rate order.

g. *Too strong a developer*, or using in summer a developer suitable for winter.

h. *Keeping on the developer* after spangles of silver show in it.

i. *Developer turns muddy at once*. Developing vessel not duly cleaned. Use the bichromate solution. Bad condition of the nitrate bath. Keeping and using pyrogallie acid dissolved in water instead of alcohol.

In the case of glass positives, fogging, when superficial, may be wiped off carefully with soft cotton-wool.

7. *Temperature of the Dark Room*.—Either extreme of temperature may cause fogging. In *very hot weather*, use less iron and more acetic acid. Some operators find it advantageous to place the bath in a vessel of cold water, to keep down the temperature.

In *very cold weather*, if the dark room be not artificially heated, the chemicals will not act well. Great perplexity is sometimes caused to inexperienced operators in this way, who will perhaps suddenly find that they pass from success to failure without any assignable reason, and only learn by the most painful experience the real source of their trouble. A temperature of about 65° is always the best, though considerable variation may occur before evil results.

Veiled (that is, very slightly fogged) negatives often print as well as brighter looking ones. If the veiling reaches the extent of slight fogging, a *clearing* process may be resorted to in either of several ways. A very weak solution of sesquichloride of iron may be washed over the plate. Or it may be washed a little with weak Lugol's solution, and then thrown into the fixing bath. Or the plate may be *chlorized* (see article on After-intensification) to a very moderate extent, and then passed through the fixing bath. Whichever plan is adopted, experience should be first gained on worthless negatives.

8. *Dew Collecting on the Lens*.—In hot damp weather dew may, at any time, collect upon the lens almost in a moment. This is especially apt to happen in passing from a cool, shaded spot to a warm, damp one. Watchfulness for this cause of trouble will be particularly needed in warm, damp, steamy weather.

9. In portraiture, an excess of diffused irregularly reflected light may veil the plate.

§ 2.—Thickness of the Film.

A *thin gray film*, so appearing when removed from the sensitizing bath, may be caused by too strong a bath, which at first acts rapidly upon the film, but gradually diminishes its density. This is the case with *ordinary collodion*. With a collodion containing bromide only, intended for the dry process, thinness of the film results from *too weak* a bath.

A *thin bluish film*, with wet plates, indicates insufficient salting of the collodion, or insufficient time in the bath. With collodio-bromide plates, it indicates that the collodion has not stood long enough after sensitizing.

Very old collodion will sometimes give very thin, transparent films, as will also a foul nitrate bath.

§ 3.—Irregularity of the Film, Crapy and Structural Line, Warty Lumps, Granularity, &c.

Crapy Lines.—1. Too watery alcohol or ether. (Fig. 125, lower corner.)

Fig. 125.



It does not necessarily follow that the materials are in fault as purchased, for the water may have been inadvertently introduced by the photographer himself. After cleaning a bottle, in which collodion is to be made, proceed as follows: Drain it well, pour in an ounce or two of alcohol, shake well so that the alcohol wets every part, pour it out, and repeat the operation. The quantity of water that may be introduced by a wet bottle is more than would be supposed.

2. Neglect to rock the plate from side to side, after collodionizing, especially when using a rather thick collodion. If this is the case, thin with equal parts alcohol and ether. Before deciding, however, that the collodion requires thinning, the operator, if not experienced, should endeavor to satisfy himself that the fault is not in his manipulation: thinning should not be unnecessarily resorted to.

The larger the plate the thinner must be the collodion. A small plate can be managed with a collodion which will inevitably give crapy lines when used for a large one.

Excessive cold may produce crapy lines.

Ridges.—1. Too much pyroxyline in collodion. 2. Too much alcohol and too little ether. (Both these defects are cured by adding a little ether.) 3. Excess of ether may, however, produce a similar effect. 4. Bad cotton, tending to gelatinize; or the collodion may have become too thick by the agency of bromide of cadmium. The action of this substance upon collodion is very remarkable, and varies extremely at different times.

Mottling may arise from irregularity in the porosity of the film, so that the developer penetrates irregularly. It usually results from using *too thick a collodion*; sometimes from not plunging the plate into the bath soon enough after coating. Mixing with ether and immersing as soon as set will usually remove this trouble, which is most apt to show itself in the flat tints, especially in semi-opaque skies. Or it may arise from a bad quality of cotton. Cottons vary extremely in this respect; some have much tendency to mottling, others none at all. Or the alcohol may be too watery.

Collodion that has thickened through the agency of bromide of cadmium, may be made to work by mixing with very fluid collodion. Much circumspection is, however, needed. The mixture should stand for several days, with occasional shaking, and then be carefully filtered.

Blistering is not a common fault, but arises from using a too old and rotten collodion.

Warty Lumps.—As the collodion film dries after coating, any solid particles present collect around them a portion of the collodion, making little raised prominences. Most commonly, these are caused by fine filaments, either of wool, from the dust caused by wear of clothes and carpets, or of undissolved fibres of pyroxyline. These little warty places, examined with a microscope, present the appearance seen at Fig. 126. When motes are visible as the film flows over the plates, they can often be *float*ed off by pouring on an abundant quantity, and managing to make the collodion, as it flows off, carry away the

Fig. 126.

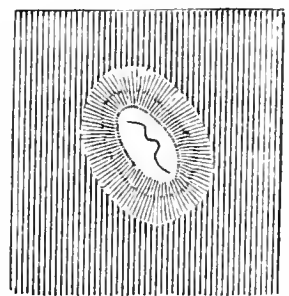

A warty lump magnified, showing a filament nucleus.

mote. Careful filtering of the collodion, and thorough brushing off of the plate *immediately before coating*, are the best preventives. In field work it is often best to take several small bottles of collodion rather than one larger one.

Want of homogeneity in the collodion must result in irregularity of density and streakiness. If different collodions be mixed without sufficient shaking; collodion that drains off from the plate is always denser, and sinks to the bottom if drained off into other collodion. By standing a long time, the mixed collodion may become homogeneous by diffusion, but it is unsafe to trust to this.

Again, suppose the drainings from the plates have been received, as they always should be, into a separate bottle, and that a quantity of such be filtered in a collodion filter, of which the bottom part is already partly filled with collodion, each drop will sink to the bottom, and the two collodions will remain quite separate. If poured out, and handled carelessly, there will be formed an irregular mixture which cannot diffuse itself with perfect regularity over glass plates.

Therefore, collodions either should be kept thoroughly separate, or, if mixed, should be mixed thoroughly by shaking, and then be either filtered in separate lots, or allowed to settle separately. Those curious to observe the action of collodions in mixing, can tinge one portion with a little rosaniline, by which means it can be distinguished in its movements.

Granularity.—After a certain time of action, the iron developer will always become muddy; and if allowed to remain on the plate in this condition, it may *fog*; or, if it does not, it will probably form a gray, granular deposit, destructive to the fineness of the negative. A negative, to give a rich, velvety print, should be made up of an extremely fine silver deposit. Too much bromide in the collodion will also cause granularity in the image.

§ 4.—Transparent Mottling at one Corner of the Plate.

This is owing to the heat of the fingers. It will be found that these marks always come at the corner by which the plate was held whilst being collodionized. (See Fig. 125, upper corner.) Often, if the plate be held up to the light before putting into the dark slide, these irregularities will be perfectly visible.

What is remarkable is that, in the great majority of instances,

the plate can be held without this result following. It appears to come only with certain temperatures and conditions of the atmosphere, and principally in cool weather. The remedy is to fold up a piece of paper, and keep it between the finger-ends and the bottom of the plate. In fact, this sort of marking is so great an annoyance where it comes, and so irregular in its coming, that it is a good plan always to use the paper; it is little trouble, and the cure is perfect.

In making dry plates, this precaution should never be neglected.

This sort of mottling can always be distinguished from that which arises from bad cotton or bad alcohol (see last section) by the marks corresponding with the shape and position of the fingers.

§ 5.—Defects in the Image.

Image strong but coarse. Too much pyroxyline.

Image fine but weak. Too little pyroxyline.

Too much Contrast.—1. Under exposure followed by over-development is by far the most common cause. 2. Too little pyroxyline in the collodion. 3. Bromide either wanting entirely or too little of it. 4. The introduction of a great deal too much bromide will produce the same effect. That is, a little too much bromide will make the image too flat, whilst a still greater excess will render it harsh. 5. Acidity of collodion. (See also §13, Insensitiveness.) 6. Use of old, red collodion. 7. It has been said that alkalinity of collodion may also produce this defect. 8. Insufficient salting of collodion. 9. Old and foul nitrate bath. Although by good management a negative bath can be kept in working order for a very long time, still the best rendering of strong contrasts will always be made by a nearly new and pure bath. Shaded foliage in well-lighted scenes and instantaneous effects will be better rendered by plates made under these conditions. If the bath wants sunning, it may be expected to give harsh pictures. 10. Too intense a pyroxyline. 11. Working in too cold temperatures.

Too Little Contrast.—1. Over-exposure. 2. Too much bromide. 3. Alkaline collodion.

Too Much Vigor.—Powerful, slow-printing negatives, requiring sunshine and long exposure to print, come with a thick, highly salted collodion and rich nitrate bath. Such will need to be printed with a weak positive bath and sunlight.

Too Little Vigor.—Good negatives, except that they are thin, yet very delicate and full of detail, are got with fluid collodion, lightly salted and sensitized in weak baths. Such will need a rich positive bath and printing in the shade.

This fault may arise from under or over exposure, the effects of which are, however, different. In the under-exposed image, the least defective parts will be the high lights of the object, which will in general be good, and the worse lighted parts will be defective. Where the picture is over-exposed, the reverse will be the case. Generally speaking, in an under-exposed picture, especially after redevelopment, the contrasts will be too great. An over-exposed picture will be gray and feeble, and deficient in contrast.

It may easily happen that a negative may be condemned as thin and flat, when in reality it may need nothing else than printing on paper sensitized with a materially richer positive bath.

Weakness may also arise from exhaustion of the negative bath, in which case it must receive more nitrate of silver. Now that more bromide is used in the collodion, a thirty-grain bath is no longer sufficient, but forty to forty-five grains give a better result. The employment of these strong nitrate baths has become much more general than at the time when the first edition of this manual was published. A strong negative bath tends to keep the iodide and bromide of silver (and consequently the image) *within the film*. A weak bath tends to give a superficial image.

Thin White or Gray Image difficult to Intensify.—This is generally the result of having too much nitric acid in the bath. Add a very little bicarbonate of sodium. If, at the same time, the bath gives pinholes, dilute it, render it alkaline with bicarbonate of sodium, sun it, filter, and then faintly acidulate.

The following causes are assigned by Hardwich as leading to weak and slaty-blue images: Negative bath newly made with impure crystals of nitrate of silver. Too much free iodine in the collodion. Camera image very weak, as in copying old manuscripts, etc., full size. Use of a negative collodion made from weak pyroxyline. Sulphuric acid left in the collodion from imperfect washing. Coating large plates too leisurely in hot weather: the film dries, and there is no penetration of the developer. Over-exposure.

Half Tone.—The greatest beauty of result will always depend upon the presence of plenty of varied half-tone, relieved and supported by a certain quantity of deep shadows and high lights. A negative that consists chiefly of dark shadows and bright lights, with but little half-tone, will always be greatly inferior in effect. Nothing can compensate for the absence of these broad soft half-shades, which are abundantly present in all good work. No royal road to this result can be indicated: it comes by a full, but not excessive, exposure; collodion well, but not excessively, bromized; careful arrangement of light; and judicious development. Those who find great difficulty in subduing contrast may find it a valuable hint to increase their exposures, and dilute their developer proportionately, as otherwise the prolonged exposure might lead to flatness.

Two Images at Once.—Imperfect cleaning. Remedy: Use the bichromate mixture.

Blurring or Halation.—Several different sorts of blurring present themselves.

1. Internal reflection, *i. e.*, from the back surface of the glass. This vexatious evil occurs in proportion to the transparency of the film, except that, in the wet process, there is apparently left a portion of iodide and bromide unconverted, at the bottom of the film, which tends to check it. Therefore this difficulty exists less in wet than in dry plates. Nevertheless, wet plates are far from being free from it. In taking views of interiors, the windows are apt to be blurred. Generally speaking, blurring shows itself most where a brilliant light comes next to a deep shadow. Especially where a dark portion is surrounded by high lights, as in the case where dark objects are projected against the sky, or, still more, against bright clouds. In this way, roofs of houses, instead of being bordered by a well-defined line, will shade off, as it were, into the sky. Small objects projected against the sky, as, for example, a lightning-rod, may be obliterated almost entirely. With wet plates the remedy is to apply a piece of wet red blotting-paper; with dry plates, to paint the back with a mixture of annatto, glycerine, and water, as directed under the head of dry plate work.

2. Where a high light meets a dark shadow, if the portion of the light next the shadow is too light, the result is that the dark object is surrounded by a light band. This is only seen in wet

plate work. In the shadow, the development consumes but little of the nitrate of silver, so that the adjoining part of the high light is developed in the presence of a solution richer in silver than the rest of it.

3. The image seems to slide off into the portion next below. This only happens with wet plates, and in cases of difficult development, owing to a cold temperature, a weak image, etc.

4. Objects moved by the wind are also blurred. If a bough be projected against the sky, and moves during exposure, the white light from the sky may almost obliterate the image of the bough. Any blurring by the wind produces a most disagreeable effect upon the picture.

Part of the Image weaker than the Rest, with a distinct Boundary.—This is occasioned by not carrying the developer over the whole plate with a single sweep.

Irregular Refractions.—When a piece of smooth ground intervenes between the camera and the objects, a strong sun falling upon the ground may give rise to irregular movements of rarefied air, which are capable of destroying the sharpness of that part of the image that is just over the line of the ground.

§ 6.—Splitting and Slipping of the Film.

1. *Splitting in Sensitizing Bath.*—1. Immersing too soon in the bath, before the film is properly set. 2. Ill-cleaned, greasy, or damp glass. 3. Omitting to roughen the edges. 4. Too much alcohol in the collodion. 5. Too much salting. 6. Alcohol too watery. 7. Immersing the plate too roughly. 8. Pyroxyline made in too strong acids.

2. *Splitting in Washing.*—Bad quality of pyroxyline; also, the faults above enumerated may exert their influence in the washing as well as in the sensitizing.

3. *Splitting in Drying.*—This may also be the fault of the pyroxyline, but it is apt to result from the treatment which the film has received. Much redevelopment with pyrogallie acid and silver is very apt to cause the film to split. Treatment with mercury for forcing (which see) also makes the film very tender. Remedy: coat the rest of the plates (when warned by one splitting) that are in danger, with a solution of gum in water, about thirty grains to the ounce, or with one of gelatine, about half as

strong. This will not take the place of varnishing, which must be done as usual, unless but few copies are wanted, and little value is attached to the plate.

Splitting in drying may also arise from an insufficient quantity of pyroxyline in the collodion, or from too large a proportion of ether. Too alkaline a collodion gives a weak film.

In the case of dry plates, a tendency to split at the edges will occur with some sorts of cotton that otherwise are all that can be desired. In such cases edge with solution of rubber in benzole, not only before coating as usual, but a second time before developing.

Slipping off of the Film.—Omitting to roughen the edges. Bad or imperfect cleaning. Old and acid negative bath. Immersing too quickly. Pyroxyline of bad quality, or too old.

§ 7.—Want of Sharpness.

1. The necessity for having the sensitive film occupy the precise position of the ground glass, has been before dwelt on. Without the nicest attention to the perfect adjustment of the camera in this respect, perfect sharpness is impossible. Careless focussing may also have been done. And some lenses have no focus at all, but may be racked in and out for half an inch, without great variation, being really sharp nowhere. Such are, of course, worthless, and with a bad lens *nothing* can be accomplished. It will sometimes happen that, after a lens has been taken to pieces to clean, the parts will be put together wrongly, either through simple inadvertence or from want of knowledge. When bad results are got, they seem inexplicable, and perhaps the optician is blamed for sending out a bad lens. The figures in the earlier portion of this book will show the proper arrangement of the parts of the various combinations.

2. *Camera Moving During the Exposure.*—This may arise from carelessness or from the wind. A simple mode of avoiding the latter consists in fastening a string to the under part of the tripod head which hangs down and ends with a loop reaching nearly to the ground. The foot placed in this loop and pressed forcibly down, holds the camera securely in its position, supposing always that the legs rest on a hard surface. On a yielding surface, the legs might sink during the exposure, enough, at least, to destroy the sharpness.

3. Want of coincidence between the chemical and visual foci.

§ 8.—Streaks.

There are several causes that are fruitful in streaks which may utterly ruin the negative.

1. *Immersing the Plate too Rapidly.*—The mixed alcohol and ether, with which the film is saturated, gives it a repellent action to the bath solution, and if the plate be rapidly lowered into it, parallel streaks may follow. As some collodions are more repellent than others, a degree of rapidity may produce this result with one that does not with another.

2. *Removing too soon from the Negative Bath.*—When this has been done, oily-looking branching lines may be seen at once, if the reflection of a light be caught on the surface (for this reason the light ought to be arranged with special reference to observing the surface of the plate as it is removed from the bath). These streaks will appear in the development.

3. *Repellent Action of the Film on the Developer.*—The developer for an old bath must always contain a certain amount of alcohol to keep up its relation with the bath solution. When the negative bath is charged with alcohol and ether, the developer may cease to mix quickly and evenly with the bath solution on the plate, and may collect on it in ridges; under these ridges the plate develops faster, and consequently they are represented by dark streaks in the image. (See B, Fig. 127.) One point is especially worthy of attention. Often the developer on the film is in a condition that it just barely holds together in an even film so long as the plate is level, ready to break into ridges the moment the plate is tilted up to look through, for the purpose of judging whether it is sufficiently developed. The moment this breaking up takes place, the development becomes unequal, and streaks are formed. Numbers of otherwise successful plates are spoiled in the development in this way, and the danger must constantly be borne in mind. Generally it may be said that (unless the operator is quite sure that his materials have no tendency to this defect) it is a safer way to let the iron development go as far as is judged safe, then *first* wash it off, and then hold up to the light and examine. Unless the picture flashes up very suddenly and quickly, it is safe to let the iron development do all it can, before washing. Then wash off; if the negative is found, on looking through it, to be of the right density, all is right. If not, redevelop with pyrogallie acid, citric acid, and

nitrate of silver, taking care not to pour on the solution till every atom of the pyrogallic acid is dissolved, or else to keep the pyrogallic acid in solution.

When, in examining a negative, it is found that along the edge which was farthest from the operator during development there are streaks, especially branching streaks, the operator may be pretty sure that the fault arises from the cause here described. And if he doubts it, let him watch the plate from the first application of the developer to its *complete* washing off, making sure that the film was unbroken, and even for every second of time. On that negative the streaks will be absent, always supposing it was not removed too soon from the negative bath. (See 2.)

Where a great tendency exists in the negative bath to form these streaks, it is well to agitate the plate, during immersion, from side to side, as well as up and down. In fact, this last is a very good practice for habitual adoption. A repellent action in the film may arise from the use of too strong alcohol and of too much ether in the collodion. Such films dry rapidly, do not take the nitrate bath well, and repel the developer.

Blanchard has remarked that the keeping qualities of plates may be greatly increased by using a good proportion of bromide, two to two and a half grains to the ounce, and removing from the bath as soon as the oily lines disappear—further, hastening that time by keeping the plate constantly in motion from its first entrance into the bath. In this way some of the bromide may remain undecomposed by the silver bath, and, decomposition continuing after the removal from the bath, the concentration of the nitrate of silver and its consequent evils are prevented. He affirms that in this way he has been able to keep a plate for three hours. Such plates must be developed without sulphate of copper in the developer, or brown fogging may result.

4. *Omitting to wipe the back, or to drain sufficiently.*

5. *If the table is allowed to be sloppy, it will follow that the bottoms of the developing vessels will become wet. When they are turned over in throwing the developer on the plate, there will be a tendency in any liquid adhering to the bottom to run along the side and mix with the liquid poured out from the vessel upon the plate. Such a result can hardly fail to produce ugly stains.*

6. *Inequalities of Temperature.*—It has been affirmed that when a material difference in the temperature of the bath and developer exists, this may be the cause of streaks.

7. *Streaks Descending more or less Perpendicularly from the Upper Part of the Plate.*—During exposure the bath solution drains down to the edge of the plate, and tends to flow thence upon the edge of the dark frame. When collected there in a drop, it easily rises again by capillary attraction as the film becomes drier by standing, and mounts up the film again, so giving rise to a streak. Remedies: 1. Wipe out the dark slide. 2. Attach a piece of blotting board to the edge of the plate. 3. Drain better after removing from the bath and before placing in the dark slide.

Another source is changing the position of the plate after it has drained after removal from the sensitive bath. If the plate after draining be turned so that what was the bottom becomes a side, the change in the direction of the currents will produce streaks that infallibly ruin the negative.

Neglect to keep the dark slide always in one position till the plate is out of it will evidently produce the same result.

In a word, the plate, after it has *once begun to drain*, must remain with the *same side down* till, by the completion of the development, danger is ended.

8. *Streaks in the Direction of the Dip* may be caused by the projection of the dipper that holds the plate; this may cause irregular currents over the plate as the dipper descends. Where this tendency exists, it may be checked by lowering the plate very gently and slowly into the bath. The ether in the collodion mixes only very slowly with the bath solution, and by rising in currents along the surface of the plate may cause streaks. Remedy: move the plate from side to side as well as up and down. In fact, this lateral motion is well to practise as a habit, together with the regular up and down movement. Scum on the surface of the bath may also cause this defect; a piece of blotting-paper drawn lightly over the surface will remove the scum.

9. *Streaks along the Border, or working in from the Borders.*—1. If the film becomes loose at any part of the edge, hyposulphite may remain under it and escape complete removal by a short washing. If then the plate be reinforced with pyro and silver, brown streaks may result. 2. Redeveloper getting under the film.

10. *Parallel Sets of Smearly Streaks or Lines.*—Cleaning marks. Every sort of cleaning and rubbing upon the plate leaves invisible traces, which may subsequently come out. Whether or not they will do so depends upon various influences: If the development is much pushed; if the bath or other chemicals are in a

condition tending slightly to fogginess, the tendency to abnormal deposit will be apt to show itself by first depositing on the cleaning marks. Much also will depend upon the cleaning, as, if the plate was well cleaned first in the bath; if the chemicals used in cleaning were removed or not; if the paper or rags used in rubbing were clean and fresh, or old and soiled; if rubbing were too hard.

Or the operations immediately preceding coating may have been in fault, as if the broad soft brush used for removing dust were soiled or damp; or if there were any deposit of dampness from the atmosphere on the plate when brushed, which dampness would by the brushing be drawn into streaks, and, moreover, soil the brush and spoil also the next following plate. Remedy, or, rather, prevention: keep the plates between sheets of clean blotting-paper in a tin box, and the brush with them, removing each plate as wanted only. Avoid removing the plates from a cold to a warmer room shortly before using.

§ 9.—Transparent Spots and Pinholes.

Pinholes.—Even to experienced photographers pinholes are a source of no small trouble. They consist of small transparent dots in the negative, and are generally occasioned by the presence of opaque matter adhering to the plate and interposing between the light and the plate. During the subsequent operations these are removed, and the portion of iodide beneath having been sheltered from the light, dissolves out in the hyposulphite. These pinholes have been traced to the following sources:—

1. Dust in the bath—remedy, filtration.

2. Crystals of iodo-nitrate of silver floating in the bath.

Iodide of silver is capable of dissolving in nitrate of silver, and certain conditions of the bath appear greatly to favor this solution. A new bath may be pretty thoroughly saturated with iodide of silver and yet give no pinholes, whereas an old bath can at times scarcely be kept free from them, and, even if removed by appropriate treatment, they quickly return. The treatment is as follows:—

a. Add a few drops of solution of sal ammoniac, and filter. This is a palliative; the pinholes mostly soon return.

b. Take *one-half* the bath, and pour it slowly into a quantity of water about its own bulk (do not reverse this), that is, if you have

a thirty-ounce bath, pour fifteen ounces of it into fifteen ounces of water, and filter. Add the rest of the bath, without filtration, and then add forty grains of nitrate of silver for each ounce of water added, unless the bath was at the time impoverished, in which case, of course, the addition must be larger. Sun it, and filter.

In some states of the bath this treatment will give effectual relief for a considerable time. But an old bath seems to acquire an increasing tendency to dissolve out the iodide of silver from the plate and precipitate it in these irritating crystals. When it is found that this tendency to recur is obstinate, it is better to—

c. Evaporate the bath to dryness in a porcelain basin; and if, after going down to thorough dryness, the heat be raised gradually till the saline mass fuses, it will be so much the better. But even evaporation to dryness, without fusing, will be a valuable help. For the presence of alcohol in the bath, introduced by the collodion on the plates, seems greatly to facilitate the solution of the iodide and the formation of iodo-nitrate; the dry mass when dissolved in water gives a milky liquid, by reason of the iodide now become insoluble, and which is got rid of by filtration. If the heat have been raised to the fusing point, the riddance of the iodide seems to be still more complete; the fused nitrate may be used as new, remembering, however, that it contains alkaline nitrate, and is not all silver-nitrate, more, therefore (if weighed), will be needed than of unmixed nitrate of silver. Probably the bath will *not* require acidulating, and acid should not be added till it is found that a trial plate is fogged without.

3. Another source has lately been brought forward as causing pinholes, viz., the presenee of sulphuric acid, or sulphates, in the water. Trouble from this source is, however, rare.

4. Some hold that acidulating with acetic acid gradually leads to pinholes by reason of formation of aetate of silver.

5. If the salting in the collodion is not thoroughly dissolved, it may remain as a fine powder in suspension, and every grain of it may be expected to cause an insensitve spot, which may be much larger than the grain itself, as its influence will extend around. The bromides are less soluble in alcohol and ether than the iodides, especially the bromide of potassium; and this substance, even if not introduced as such into the collodion, will always be formed if iodide of potassium is used in connection with any

bromide. The stronger and better the alcohol and ether the more liable they will be to this trouble.

Therefore, if it be considered essential to introduce a potassium salt, it will be necessary to select a cotton which will work well with alcohol not too high. In this respect cottons differ very widely, some requiring the strongest solvents, and some working with quite watery ones. Cotton having this last quality will be appropriate for ambrotypes and ferrotypes, as it is for such that potassium is commonly introduced into the collodion.

As a remedy, introduce a few drops of water, shake thoroughly, set in not too cool a place, and at the end of twenty-four hours filter through a close filter.

Or dilute the collodion with a little plain collodion, thus increasing its solvent powers. According to V. Blanchard, this is very effective, when, after working for some time well, one is suddenly troubled with pinholes. The explanation of the remedy is evident.

Continual moving of the plate whilst in the nitrate bath, without ceasing till it is withdrawn, is also recommended by the same photographer.

Large Clear or Hazy Spots.—1. When the developer is not swept along the upper edge as here recommended, but poured over the plate in the same manner as the collodion (as is practised by some operators), a transparent spot, half an inch or more in diameter, is very apt to be formed unless the operator rapidly moves the hand which pours on the developer. This spot is caused by the washing away of the bath solution, so that when development sets in, that part of the film is deficient in free nitrate of silver, and is proportionally weaker in effect. 2. Collodion poured too suddenly back into the vial, making an irregular film. 3. Bad cotton, which does not thoroughly dissolve in the fluid, and which has not been properly filtered. 4. Bad collodion, too thick, or with alcohol and ether badly proportioned (*i. e.*, alcohol should be $\frac{1}{3}$ to $\frac{1}{2}$, ether $\frac{1}{2}$ to $\frac{2}{3}$). 5. A new bath, not saturated with iodide of silver, will corrode the first plates. 6. An over-strong bath may produce the like effect. 7. Keeping too long before developing may produce roundish hazy spots, especially when the bath is acidulated with nitric acid. Apparently, this happens most easily in hot weather, when the evaporation is most rapid. The bath solution becomes concentrated and dissolves out portions of the film. It does not act equally, because as it evaporates it has

a tendency to collect in drops on the surface. 8. Fragments of collodion (generally from the back of the plate) in the bath.

As mentioned elsewhere, small transparent spots in a negative should always be touched out with opaque color. This causes them to print *white* spots in the print, which are easily retouched and brought up to the surrounding shade. But a transparent spot prints dead black, and this is much more difficult to manage and the blemish is never so well concealed.

Rings.—If the collodion bottle be *held too high above the plate* in collodionizing, rings may appear in the development.

§ 10.—Comets and other Opaque Spots.

The name *comet* (A, A', Fig. 127) very aptly designates those larger or smaller spots with tails, opaque in the negative and showing more or less white if printed, so that unless but a few prints are wanted, and the photographer is willing to touch out the comet's mark, the negative may generally be considered as worthless.

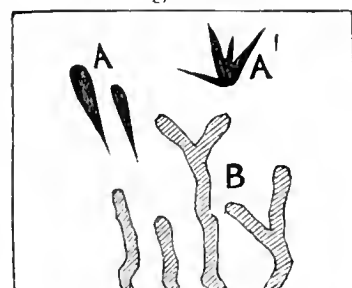

A, A', Comets.
B, Development stains.

The heads of these comets mostly are towards the direction from which the developer came, and the tails pointing to the side on which it ran off. They may be caused by anything that forms reduction at some chance point. A fragment of undissolved pyrogallie acid, unfiltered solutions of sulphate of iron, organic dust on the plate, or in the sensitizing bath, or floating on its surface, any of these causes may produce comets. Their appearance may be taken as a plain indication that one or more of the solutions worked with wants filtering.

Or, suppose that hyposulphite is spilt about the room. The grating of the feet on the floor or carpet grinds off dust which is charged with hyposulphite. If the glass be rubbed immediately before coating, it becomes electrical, and every floating mote near it is drawn to it. These are imbedded in the collodion, and on plunging the plate in the bath, they become centres of reduction. Sometimes these are even observable as dark spots on removing the plate from the bath. But if the proportion of hyposulphite

is infinitesimal, yet they may escape attention on withdrawing the plate, and cause comets.

If this dust is about the room, it can scarcely but get into the dark slide, and then in moving, especially if roughly moved, it may be transferred to the plate, and lead to comets.

Metallic hinges to the dark slide will sometimes grind off particles of metal which may be transferred to the plate. Each becomes a centre of reduction, and must lead to the formation of a spot of some sort, probably a comet.

Imperfectly filtered collodion may give rise to opaque spots. Also, neglect to wipe thoroughly the lip of the vessel from which the collodion is poured.

•Where any cause of comets is present, a strong developer tends naturally to aggravate the evil. A rather acid developer is the easiest worked with, but does not give as fine results, viz., as much transparency of shadow. At the same time, it diminishes the tendency somewhat to stains, and helps detail in high lights, such as white dresses in portraiture, or a strongly illuminated distance in landscapes; also fine lines in copying *line* engravings (not mezzotints, photographs, lithographs, or India-ink drawings), for all of which a well balanced, *i. e.*, moderately acidified, developer is needed. Finally, the developer, if not kept in continual motion over the plate, may allow particles of metallic silver to fall, which presently become nuclei of development.

Opaque spots may be caused by a lumpiness of the film, arising from some insoluble substance in the collodion. Often minute fragments of dried collodion are carried over from the neck of the pourer, by neglect to wipe after *every* pouring. The least dust in the collodion will cause these spots; after it is examined with a lens they will be found to be caused by a minute fibre of wool: it is surprising how much thickening a single fibre may cause in this way. These fibres may get into open vessels of collodion, or may have settled into vials or pourers before they were filled with collodion. Or (as this is the commonest case) they have settled on the *plate itself*, either from neglect to brush it off, or from doing so too long before coating, so that dust settles on it between times. Dust is a foe to many photographic operators, and most of all to *albumenized plates*, and every care should be taken to exclude it.

§ 11.—Lines.

1. *A pause*, however momentary, in the immersion of the plate, produces a line, generally as thin as a hair, at the place where the pause took place. With a vertical bath,

Fig. 128.

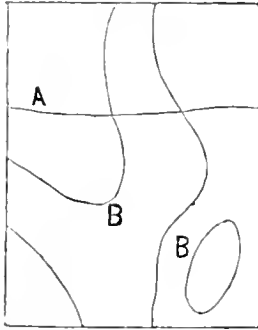

such a line is necessarily a straight, or nearly straight, one (see A, Fig. 128). With a horizontal bath the most curious curves and sinuous lines are seen (B B, same figure). If the horizontal bath has not been deep enough to cover the plate with a single wave, but pauses for a fraction of a second, the mark of that pause will inevitably appear in the development, and the negative is of course ruined.

Remedy: with a vertical bath, immerse the plate with perfect regularity. With a horizontal bath, have plenty of solution, raise the bath at one end, place the plate in at that end, raised so high that the solution leaves it, and then, at the same time, lower that end and let the other end of the plate fall gently in.

2. *Wavy Lines at Edges*.—Developer too small in quantity, or too slowly applied, especially where the plate has been kept some time after leaving the bath.

3. *Fine Parallel Vertical Lines in Direction of Dip*.—The writer has seen this result from sulphate of iron in the silver bath, thousands of such lines being thus produced.

4. *Sinuuous Lines over the Plate*.—If the film be of a very repellent nature, the bath solution may, instead of remaining as an even film, gradually collect in oily lines, or the plate may by inattention have been removed from the bath with these lines actually upon it. This repellent character (see p. 318) may come from

various sources: 1. Bad quality of cotton. 2. Alcohol and ether too high; add a very little water. 3. A horny and contractile collodion.

Fig. 129.

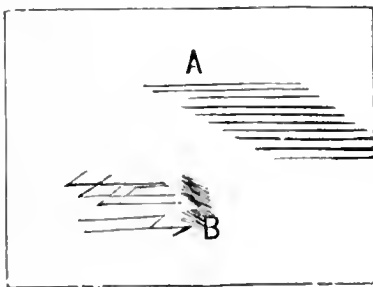

5. *Parallel Lines, darker than the Adjoining Parts*.—When a plate which has not been very well cleaned is subjected to a long and severe development, traces of the lines of the cleaning will

be forced out in the development. (See Fig. 129.) Sometimes these are simply parallel lines as at A, sometimes they show

angles as at B. These angles are where the direction of the hand was changed in the cleaning. Remedy: Clean better and rub longer.

§ 12.—Stains and Surface Markings.

Marbled Stains.—“Oyster-shell” stains of reduced silver (also called “matt silver stains”), with a gray metallic surface and in curious curved and arabesque patterns, occasionally make their appearance. They are exceedingly peculiar and unlike any other stains, and have occasioned much speculation and discussion. They come from too long an interval between collodionizing and plunging into nitrate bath, too strong a developer, or too long a development, especially with sulphate of iron.

The longer a plate is required to wait between sensitizing and development the worse will be these stains. Plates which when developed within five or ten minutes after withdrawal from the nitrate bath are perfectly clean, will sometimes, if kept for half an hour, show abundance of these stains. Some operators find them come on large plates when they do not on small.



Fig. 130.

“Marbled” or “oyster-shell” surface stains.

Or they may be caused by neglect to wipe the back of the plate, or to let it drain a sufficient time before putting it into the dark slide. In these ways bath solution may run down to the bottom of the back, and work round to the collodion film. They may also arise from scum on the surface of the bath, which is taken up by the plate, and is subsequently developed by the action of the developer. According to some reliable photographers, *iodide of ammonium in the collodion* tends strongly to the formation of this species of stains. They usually, however, indicate too long an interval between collodionizing and development. Remedy: Let the operations follow each other more rapidly. If this cannot be, use more bromide, agitate the plate the whole time that it is in the bath, and remove it from the bath the moment the oily lines disappear.

In very hot weather these stains will show themselves upon plates otherwise every way perfect, even with a bath quite sufficiently acidulated, and with a collodion containing iodine. The

longer the interval between the operations the larger and more numerous they are. They appear to depend upon the drying of the collodion film on the surface, and upon a partial return by capillary action of silver solution which has drained down to the corner. Silver solution which has once touched the holder becomes sufficiently changed to throw down its metal much more rapidly under the developer.

The writer has devised and used the following remedy with great advantage. A piece of thick blotting pad is cut to the length of the lower edge of the plate, and made about an inch and a half wide. A very narrow portion, say an eighth of an inch or less in width, is bent over to a right angle for the whole length, and after the plate is put into the holder it is raised up a little, and this bent edge is pushed in between the plate and the corners. Thus the *edge* (not the face) of the glass and of the collodion film touch this blotting-paper over the whole length, and whatever solution drains down is absorbed by the blotting pad, and is drawn round by it to the back. This remedy was found very valuable.

Or it is advisable, when such a tendency appears: 1. To carefully wipe out the dark slide with a wet cloth, in order superficially to wet the surface. 2. To place a piece of thick blotting-paper on the back, as just explained. 3. To diminish the intervals before the development as much as possible. 4. If necessary, to roll the dark slide in a damp cloth. The first remedy is, however, by far the best. (See also p. 344.)

It has been stated that these oyster-shell markings may arise from something in the *acetic acid* used in the developer, and that they have instantly disappeared by changing the specimen of acid used. Others, again, have attributed them to the greater thickness of the film at the corner where poured off, so that this portion, drying more slowly, is exposed to become loose in the nitrate bath, and to retain some bath solution beneath it.

Stains of this sort are very superficial, and, by dexterous manipulation, may often be entirely removed. The surface of the collodion is to be thoroughly wetted, best with alcohol, and a piece of *very* soft paper is well moistened, and a point of it carefully and repeatedly drawn over the stain. Unless the pressure is exceedingly gentle, the film gives way, but when care is taken, the stains disappear wonderfully. The writer has seen a third of the surface of a negative covered with these stains, and yet has succeeded in

getting rid of them with care and patience. A kind of very thin brown paper, made of jute, is that which has been found to answer best. It becomes exceedingly tender when wet. The operation is best performed *after* fixing.

Brown Stains.—If it is desired to reinforce *after* fixing with hyposulphite, careful washing is necessary before the pyro and silver are applied; if traces of hypo remain in or under the film, a brown stain of sulphide of silver makes its appearance the instant the redeveloping solution is put on the plate.

These stains are also said to arise from using pyrogallic acid with too little acetic acid, when the water is hard (limestone water), and sometimes from white light admitted to the dark room. Redeveloper getting under the film will stain brown.

If the collodion be alkaline it will be highly sensitive, and tend to give flat images, and at the same time to stain with the slightest cause. The least impurity on the glass, the least mismanagement of development, may be expected to spoil the plate.

Neglect to keep the plate-holder clean will give rise to very troublesome markings. The all but universal use of *glass corners* in the slides has largely diminished the injuries from dirty plate-holders, nevertheless it is still advisable to be on the safe side. Paraffining the slide, or, what is easier, rubbing it well with lard, prevents the soaking in of droppings and drainings, and renders the slides more easy to keep clean.

It seems scarcely necessary to say that any solution left upon the glass corners for want of wiping is transferred to the next plate, and may show itself in the production of different sorts of stains according to the condition of the chemicals.

Irregular Markings are said, in some cases, to arise from the use of too strong alcohol and ether in the collodion. Mr. Terry mentions a case as occurring in a gallery in which not a perfect negative had been made in a week, and where the trouble was at once removed by adding a few drops of water to the collodion. It had been made by the photographer himself; absolute alcohol was used instead of 95 per cent.¹

¹ Really absolute alcohol is rarely to be met with in commerce. The difference between 95 per cent. alcohol and absolute is over 25 drops of water to the fluidounce, rather more than 5 drops to each hundred. It will thus appear how important it is to understand the exact strength of the materials used.

§ 13.—Faults in Fixing.

Feathery Markings over the Plate.—Yellowish feathery markings are owing to insufficient fixing. These may appear at any part of the plate, most frequently, however, at the corner at which the collodion was poured off. At times a yellow shade is left over the whole plate; this indicates a still more imperfect fixing.

Fig. 131.



When this fault is not noticed until the plate has been washed and dried, particular care is necessary; for plates thrown into hyposulphite a second time are almost certain to loosen in the film, or to split in some part of the operation, either in the fixing, or washing, or the drying; therefore, the best precaution is to take a grain solution of

India-rubber in benzole, to pour out an ounce or two of it into a pan, and tilt the pan upward at one side, so that the solution may lie in the angle opposite. We thus have a pool the length of the pan, and about one-fourth of an inch deep in the middle. The four edges of the plate are to be plunged in this successively, giving each a full minute to allow the varnish to soak in, and also to allow the previous side to drain and dry before it becomes the top. The plate thus cemented fast at the edges, will stand the necessary treatment without difficulty. After refixing and washing, coat with gum-water or dilute albumen, dry and varnish.

Image Weakens too much in Fixing.—The fixing bath may be too strong and need weakening. The result may also come from too weak a negative bath, used too long without strengthening up. The iodide of silver is then formed too much on the surface of, instead of within, the film. Or the development may have not been continued sufficiently long. It should be borne in mind that the portions of the image formed by redevelopment are less easily attacked by the fixing bath than those formed in the first development.

§ 14.—Faults in Varnishing.

Drying Dead.—This may result from one or more of three distinct causes.

1. Want of dryness of the film. As water curdles varnish by precipitating the resin, so any dampness in the film will produce a similar effect. Surface drying is insufficient. The film must be dry clear through to the glass. By standing for a day, the film dries sufficiently in dry weather, but a damp atmosphere, even in sunny weather, will dampen films to that extent (even if they were previously dry) that the varnishing may be affected. As a general thing, it is best to varnish in dry weather only; but if it is to be done in damp weather, artificial heat must be used. Merely warming the plate will not dry it; it must be kept warm for some little time.

2. Insufficient penetration. Varnishes penetrate rather more slowly than many persons imagine, and if poured off before penetration has taken place, the varnish continues to soak in, and thus the upper portion has not enough left to give it a glossy surface. After the plate has been completely covered, the writer advises to count ten or twelve seconds before beginning to pour off.

3. Insufficient heat. Some varnishes require more heat than others, and if enough is not applied they dry dead. Most varnishes require heat both before and after applying.

Remedy for Deadness.—Flow with alcohol (see below).

Ridges.—If the pool of varnish be allowed to stop too long in any position, it dries at the edge and makes a ridge, and the tendency will always be greater in proportion as the plate is hotter. If, while varnishing, the photographer sees that he has made a ridge, he can, if it is not a bad one, get rid of it by pouring an abundant supply of varnish on, and letting it remain longer on the plate than usual.

Different varnishes work differently, and sometimes the mere change from one that the photographer is accustomed to, to another equally good, but different, will cause him to make ridges.

When, after drying a negative by heat, the varnish is found to have made a ridge across the film likely to show in the printing, or has dried sufficiently dead to unfavorably affect the print, it is not necessary to remove the whole of the varnish. The writer simply flows the negative over with 95 per cent. alcohol, letting it stand on the film for two or three seconds, and pours off; then warms the plate and applies another coat of varnish. For this last varnishing it is best to use a thinner varnish, lest the coat become too thick. Therefore dilute the varnish (if a spirit var-

nish, and the writer advises to use none other) with an equal bulk of alcohol. The same remedy applies for *drying dead*.

Scaling Off after a Lapse of Time.—This arises from leaving the varnish on too short a time before pouring off. Those places where it has not soaked through to the glass will always be liable to scale off. Or if the plate has been badly washed and hyposulphite crystallizes under the film. Exposure of the negative to damp atmosphere. Great changes of atmosphere, as if the room is allowed to frequently become very cold and then is strongly heated. Bad varnish, containing no essential oil (oil of lavender, etc.). Coating with gum-water before varnishing, in order to prevent splitting in drying.

Any varnish which tends in the least degree to show this defect should be rejected without hesitation. Under the head of varnishes, will be given further on several formulas for varnishes which will resist the action of moisture so completely that negatives varnished with them may lie under water for many weeks without injury of any sort.

Dissolving of the Image in Varnishing.—The cotton too soluble in alcohol alone without ether. Alcohol in the varnish too strong. Remedy: add a little water; shake well, and if not quite bright, filter through paper; or use a benzole varnish. This trouble comes chiefly with pyroxyline made at a low temperature with weak acids; and as, of late years, the tendency has been to strengthen the acids, and counterbalance this by raising the temperature, the tendency to dissolve in varnishing occurs less frequently than formerly.

Honeycomb Cracks.—The varnish after a time rises in ridges, and finally parts. Cause: insufficient removal of hyposulphite in washing. If attended to in time, this may be remedied. Alcohol is put into a pan, and the plate put over it, face down, until the varnish softens and returns to its position; or the plate is simply flowed over with hot alcohol. The ridges sink down sufficiently not to affect the printing.

Parallel Lines running diagonally down the Plate.—Certain varnishes, and especially thick ones, require to be rocked whilst draining and drying, for want of which this trouble may arise.

Scratching in Handling.—Too thin a varnish will not afford an adequate protection to the film, which may thus be unable to stand ordinary wear. A habit of thinning the varnish with alcohol may easily be carried to excess, and lead to this trouble.

Generally speaking, the solid gum should be in the proportion of one ounce to seven fluidounces of alcohol, with some essential oil to prevent cracking.

A more common source of this trouble lies in the use of varnishes made with too soft gums. *Lac* is liable to this objection. The sandarac varnish, for which a formula will be given in the chapter on varnishes, gives an extremely strong, hard coat.

Specks and Irregularities on the Surface.—Although the varnish have been perfectly clean and bright, and although the negative may have been carefully brushed off immediately before applying the varnish, it will often happen that there will be specks and irregularities. Examined with a lens, these will mostly show a filament of wool (from abrasion of clothes or carpets) in the centre as the cause. The air is mostly much fuller of dust than we imagine, and these filaments will settle on the plate even in the few seconds between brushing and coating.

‡ 15.—Miscellaneous.

1. *No Image at all.*—In copying by a bad light, if too small a diaphragm be used, and a much too short exposure be given, with insensitive chemicals, the developer may fail to bring anything out. A very exceptional case. In some states of the negative both cadmium collodions will fail to give any image at all, when the mere substitution of a collodion made chiefly with salts of ammonium will lead to good results immediately (p. 136).

2. *Insensitiveness* arises either from too acid a condition of the negative bath or from the use of too old acid, or dark collodion. If from the latter cause, it will be at once removed by substituting a collodion in good condition. And if the old collodion be not too defective, it may be used up by mixing with some that has been very newly prepared of thoroughly neutral materials, preferably with cadmium salts only, and which by the admixture of an older collodion will at once pass into good condition.

It is usually collodions made with alkalies that become insensitive. Cadmium collodions will keep in cool places for several years.

As to the proportions in which to mix new and old collodions, one part of old may be added to three, four, or five of new, ac-

ording to circumstances. If the old collodion be quite dark, it will hardly be safe to add in larger proportion than five. Over-acidity of the bath is generally the result of tampering with it—as a general rule, after your bath is once rightly made, ascribe all troubles to anything else, and apply no remedies to it, until it is certain that it is in fault. If too much acid has been added, by mistake, in making it, bicarbonate of sodium may be added very cautiously until a precipitate falls, then filter and acidulate again.

An old bath, choked with organic matter, may cause insensitiveness.

3. *The Film, after Fixing with Cyanide, shows a Bluish Color.*—Insufficient washing off after development, so that iron salt remains on the plate.

4. *Want of Adherence.*—Too much cotton in collodion. Immersing too quickly. Greasiness of plate. Too much alcohol in proportion to ether.

5. *Iodide comes off in the Bath, in Flakes.*—Too little cotton in collodion.

6. *Developer Repelled*—fails to moisten, or to act upon the film or parts of it. Collodion too gelatinous by reason of cadmium salts. Too much ether for the alcohol. Alcohol and ether too strong. Bad cotton. Waiting too long before immersion. Plate kept too long after removing from negative bath, so that it becomes surface-dry in spots.

7. *Bluish Deposit in Shadows.*—Insufficient acid in negative bath. (This appearance is not unfrequent in the glycerine and honey process.)

8. *Ghost or Flare.*—Indistinct thicker spot on the plate opposite centre of lens. Faulty lens needing to be rejected.

9. *Transparent Insensitive Band around the Plate.*—Too long delay between coating and immersing the plate.

10. *Plates have a Dusty, Powdery Look.*—Excessive deposit of iodide of silver. Filter after diluting, precisely as for pinholes. Note, this is not to be confounded with *Granularity*, which see, but the film is in this case more veiled.

II. FAILURES BELONGING ESPECIALLY TO NEGATIVES.

1. *Too Little Density.*—1. Too weak a bath. 2. Too strong a bath. 3. Over-exposure. 4. Too short a development. A be-

ginner is often so afraid of fogging, that he cuts short the development when the negative has only reached the ambrotype stage.

5. Insufficient illumination.

2. *Excessive Density*.—1. Over-development, especially with under-exposure. 2. Too much salting.

3. *Solarization*, results from over-exposure. For a film exposed to light for a gradually increasing time gains in strength up to a maximum point, then remains stationary for an exceedingly short time (in case of iodide of silver), and then loses again in the over-exposed parts, showing little tendency to take a deposit under the developer. A great disposition to solarization in a collodion indicates an insufficiency of bromides; the tendency of bromides is greatly to prolong the stationary point just spoken of.

III. FAILURES BELONGING ESPECIALLY TO AMBROTYPES AND FERROTYPES.

1. *Want of Detail in Shadows*.—Under-exposure. Too little bromide in collodion. Too old and red a collodion. Insufficient development. Too acid a negative bath. Too thin a collodion.

2. *Want of Detail in High Lights*, which are at the same time vigorous and dense. Too much development, so that the plate tends to become a negative.

3. *Grayishness or Want of Contrast*.—Over-exposure: in this case the shadows are good in respect of detail, but want depth. Use of hyposulphite of sodium as a fixer instead of cyanide.

4. *Veiling of the Shadows*.—Over-exposure. Too new a collodion. Add a little tincture of iodine, or mix with some old red collodion.

5. *Excessive Contrast*.—Too old a collodion; too acid or foul a bath. Too little bromide in collodion. Under-exposure.

6. *Dark rounded Spots* visible after backing. Pouring on the developer like collodion instead of sweeping it from along one edge.

7. *Want of Transparency in the Film when Dry*.—Bad cotton.

8. *Too Slow a Development*, may arise from too much acidification of the bath.

9. *Green or Blue Color in the Film*, according to Hardwich, may arise from too scanty a deposit of silver, depending upon either

insufficient development or over-exposure, or from too thin a collodion film. A bad cotton or a disordered bath may likewise affect unfavorably the color of the image.

IV. FAILURES IN PAPER DEVELOPMENT.

Much that has been already said applies itself necessarily to working with paper, especially the remarks on *fogging*, and effects of *under* and *over-exposure*.

Harshness.—Too much iodide.

Stains are often ascribable to handling with not perfectly clean fingers. Indeed, so absorbent is paper, that almost any touch will become visible to the developed print, even with very clean fingers. The addition of bromide has a great tendency to check the staining; and in the case of positive printing by development, where extreme brevity of exposure is not important, it will be found best to develop on chloride of silver.

The use of very weak gallic acid in connection with a lead salt and acetic acid, as proposed by the writer, and explained elsewhere, exposes less to danger of stains than other modes of development.

Sunk-in Appearance.—All development tends to this effect; developed pictures are always less brilliant than sun-prints—the picture does not so much lie upon the surface. Nor is it easy to state the causes upon which a more or less sunk-in effect depends, though the quality of the paper appears to have very much to do with it. It is far more difficult to find a good paper for developing upon, than for ordinary silver printing. When the photographer finds paper that will yield a bright print by development, such paper should be carefully placed aside for this use, and an exact note should be made of the details of the method which was found to give good results with it.

V. SILVER PRINTING.

§ 1.—Failures common to Glass and Paper Prints.

1. *Weak Gray Prints*.—Use of negatives destitute of light and shade, generally from over-exposure or bad manipulation. Also may arise from bad paper or too weak or exhausted positive bath.

2. *Harsh Black and White, or Snowy Prints*.—Over-developed negatives. Strong negatives, which would give good prints with

sunlight, may produce this fault in printing by diffuse light, especially if the light is weak, or the nitrate bath very rich.

3. *Whites turn Yellow.*—Throwing the prints into the toning bath without thoroughly removing the nitrate of silver by washing, tends to yellowness of the whites. Also exposure of the sensitive surface to light. Old hyposulphite causes the same fault. Paper kept too long after sensitizing. Remedy: Use the author's method of printing described at page 277.

Some hold that the turning yellow depends upon the bath solution having penetrated through the albumen to the paper beneath, and that consequently the shortest practicable time that the paper is left on the bath the better, especially in hot weather.

It is found that paper, after sensitizing, may be washed off with pure water, and that in that condition it keeps many days. Before use, the sensitiveness is to be restored by strong priming. Even without this it will print with very strong dense negatives. Hyposulphite dust about the room. Remedy: Tone in a separate room.

4. *Prints weakening in the Toning Bath.*—Use of bath too soon after making. Insufficient printing. Use of an acid toning bath. Remedy: Add bicarbonate of sodium, or better, acetate of sodium.

5. *Prints refuse to Tone.*—Toning bath badly made or acid (see article on *Toning Baths*). Too acid or too weak a printing bath. An acid printing bath often gives prints that will not tone well. Remedy: Drop in ammonia till the bath is alkaline to test paper. Or fume adulterated chloride of gold, or exhausted bath. Insufficient washing before immersion in the toning bath. Too cold a temperature; the bath generally works better at blood-heat. Print kept too long after printing. Impurity introduced into the toning bath, especially a trace of hyposulphite. Toning bath too freshly mixed or too strong. Fuming for too long a time with too much ammonia.

6. *Prints lose too much Intensity in Fixing.*—Insufficient printing, but oftener too thin a negative; or may arise from too weak a positive bath. Or they may have been fumed too long.

7. *Toned and Fixed Print too Red.*—Insufficient toning. Continue the toning till the redness is gone when the print is held up to the light and looked through, but avoid over-toning.

8. *Fixed and Toned Print too Blue.*—Over-toning. Poor tones, or a want of richness of tone, may arise from conducting the toning operation too rapidly.

9. *White Spots.*—Air-bubbles.

10. *Albumen dissolves in the Sensitizing Bath.*—The bath is either too weak, or alkaline; the remedy is obvious.

11. *Over-Printing.*—A very weak solution of cyanide of potassium is the best means of reducing over-printed positives. It must be applied carefully, both as respects the print and the operator, and the fingers should not be immersed in it. Strength proper will be about a half grain to ounce of water, or even less.

§ 2.—Failures Peculiar to Silver Printing on Paper.

Albumenized Paper repels the Positive Bath.—Paper too dry. Leave for twenty-four hours in damp place before sensitizing, or blot off the paper immediately on taking it from the printing bath, between folds of clean, white blotting-paper.

Stains in the Print as it comes from the Frame.—1. Soiled fingers handling the paper. Too much care can never be taken in handling photographic paper. The sources of stains by soiled or moist fingers undoubtedly often precede the purchase; in this the professional photographer has a great advantage over the amateur, that his paper is purchased in quantities, and so undergoes far less fingering. Two corners of the sheet, whether whole or cut up, should at once be folded down at the commencement of operations, and no other part of the paper be touched from first to last.

Care will not only be required as to the handling, but as to everything that the paper comes into contact with.

2. A very common source of stains is the presence of very fine metallic particles in the paper, produced by the grating of the mill-machinery. These particles, however infinitesimal, become causes of reduction, and inevitably make stains.

3. Imperfect removal of hyposulphite used in bleaching.

4. Foreign substances of almost any sort, constituting invisible imperfections in the paper. These may act in several ways. They may diminish the penetrability of the paper locally. Such portions will take up less silver and print lighter than the rest. Often these foreign matters can be detected by holding the paper up to the light and observing its regularity.

5. Irregular distribution of resin or other sizing material through the paper. Resin easily combines with silver, making a

sensitive compound. If the resin is not equally distributed, the quantity of silver compound will vary accordingly.

6. Reflected light from bright objects near the printing frame.

7. Printing by sunlight through a window-frame, with irregularities in the glass.

8. Paper not well floated on the bath, or left on it an insufficient time for the equal absorption of nitrate, causing irregular marbled stains.

9. Impurities floating on the surface of the printing bath, taken up by the paper.

Irregular or patchy effects in printing may be caused by fuming for too short a time.

Spots appearing in the Toning.—Neglect to keep the prints moving. Where one print rests upon another, the action of the toning bath is slower, and a spot results. This is a very common source of trouble, unless the necessity of care is borne steadily in view; or if the print floats on the bath, instead of being kept under the surface.

Spots in the Fixing.—Adhesion of prints to each other in the bath, by neglect to continually move them.

Want of Brilliancy.—Floating the paper too long on printing bath. Half a minute to three-quarters is sufficient, and gives a far better print than a longer time.

Prints have a Sunk-in or Mealy Appearance.—Insufficient albumenizing. Bad paper. Old and foul, or acid, printing bath. Too much salting. Old albumenized paper that has not been kept thoroughly dry, especially if chloride of sodium has been used for salting. Dampness causes the chloride, which should be wholly in the layer of albumen, to penetrate into the body of the paper. Printing bath too newly made, or paper floated too long. *Too much fuming* with ammonia, or too strong fuming, tends to produce a flat, mealy print.

Print refuses to Bronze in the Shadows while Printing.—This depends upon the salting bath having been too strong for the printing bath. Remedy: Add more nitrate of silver to the positive bath, or change the paper. Paper kept too long after sensitizing.

If the image does not bronze in the shadows by the aid of the printing, a brilliant print cannot be expected. An opposite cause may be expected to produce the opposite effect, viz., too deep bronzing and too harsh a print.

Print takes a different tone at the two ends, as, one end black

and the other blue, or one black and the other brown. Cause, irregular albumenizing of the paper, so that the coat of albumen is thicker at one part than another; where the albumen is thinnest the toning proceeds most rapidly. For this reason it is especially important, for large prints, to select the paper carefully.

Black Dot with a White Tail.—If the pin to which the sheet hung to dry was put through a wet place, a local reduction follows with this result. Pins left for some hours in an old cyanide fixing bath become silvered, and are exempt from this trouble; silver may be dissolved in cyanide for the purpose.

Albumen dissolves off in the Silvering Bath.—Bath is either *too alkaline* or *too weak in silver*.

Failures appearing only in the Toned and Fixed Print.—Troubled appearances in the substance of the paper. 1. If the chloride of silver has not been thoroughly, or rather has been very imperfectly removed, the print has a mottled look on holding up to the light, and as this remaining chloride of course darkens by continued exposure to light, the mottled appearance becomes with time more perceptible. This imperfect removal may arise from not leaving long enough in the hyposulphite bath, or from the exhaustion of the bath, or, possibly, by exposure to light before fixing. The first are the most probable causes. Remedy: Use hyposulphite of sodium liberally; one pound to twelve sheets is none too much. Make no more than wanted, and begin each day afresh, under no circumstances using a bath a second day, even if but a single print was fixed in it the previous day.

2. Cases have been observed in which the prints were in perfect order when toned and fixed, and yet exhibited stains after the final washing. This has been found to arise from the use of *zinc* vessels, or a zinc bottom to the washing trough. The more thoroughly the vessel is cleaned, the worse the spots. Remedy: Varnish thoroughly the whole surface of the zinc, or have a wood bottom with a layer of white quartz pebbles (which may be obtained from those who make a business of gravel-roofing). These are easily kept clean.

Over-contrast.—If necessary to print from a negative too harsh, the excess of contrast can be reduced by exposing the paper to light for a few seconds, or a minute, before placing it in the printing frame. The print is thus somewhat improved, but will never be first-rate.

Hard negatives will require light silvering. It often happens

that a negative is full of detail, and unobjectionable in every respect except that of being so dense that the shadows of the print are overdone before the detail in the lights come out. Such negatives will need paper very lightly silvered. Often the paper after going through the regular sensitizing may be floated for a minute on water. The writer has seen most beautiful results got in this way from negatives that would not give any good effect with ordinary silvered paper.

Blurred Spots.—A bad frame may not have brought the paper home to the glass everywhere. Many printing frames are very defective in this, that they throw all the strain into the middle of the plate, thereby endangering the safety of the negative, and getting bad definition at the edges, which is apt to be attributed to a falling off in the power of the lens. Try the frames always with a piece of plain glass, fastening down the springs and pressing up the glass with the thumbs on various parts in succession, to find how the pressure produced by the springs is distributed. The old pattern, with bars at the back, is the best by far.

Blistering of the Albumen.—1. Peculiarity of the albumen film which will not bear the sudden change from the fixing bath to pure water without endosmose. Remedy: Let the prints lie for a short time in a weak intermediate bath of hyposulphite, between the regular fixing bath and the washing. 2. Acid washing after toning in an alkaline gold bath containing alkaline carbonates. 3. Over-dryness of the albumenized paper. For this and other reasons it is a good plan to leave the paper for a day before using it in a damp place; not too damp, however, nor for too long a time, as this would lead to the working inwards of the salting, occasioning a loss of brilliancy to the print.

It has been said that the addition of a small quantity of ether ($\frac{1}{4}$ ounce to 20-ounce bath) to the fixing bath will prevent blistering.

Fading of the Prints.—Insufficient washing. Old hyposulphite fixing baths. A solution of hyposulphite of sodium in water keeps perfectly. But if used, it should be rejected and not employed on any subsequent day to that on which it was first used. Acid in the fixing bath. Use of a fixing and toning bath.

Black Specks showing first after Mounting.—Appearances of this sort may almost invariably be traced to the agency of fine metallic particles. These, by the aid of atmospheric moisture, gradually act upon the print and produce the specks. They come—

1. By trimming the print upon a brass plate. The point of the knife detaches fine particles of metal, these are by the pressure forced into the print and soon make stains upon it. Glass or hard wood should be used to cut on.

2. By using a brass form to trim by. Particles are abraded and enter the print in the same way as before. Steel or glass forms should be used exclusively.

3. By using Bristol board for mounting, on which borders or designs have been printed in gold or bronze. The designs are printed in varnish and the metallic powders are rubbed on; grains adhere elsewhere than on the design, and are not entirely removed in the subsequent brushing, but eventually destroy the print.

Crystallizations in the printing bath or on the paper may occur in consequence of the nitric acid used in preparing the ammonio-nitrate bath containing sulphuric acid: sulphate of silver is but very slightly soluble in water. A bath so contaminated may be brought into order by adding *nitrate of baryta* in solution so long as a precipitate forms. The same substance may be used to test the purity of the nitric acid used, and also to purify it, if found contaminated. When nitrate of baryta is added to a liquid containing sulphuric acid, *sulphate of baryta*, a very insoluble salt, is thrown down as a heavy white powder, easily separated either by decantation or filtration.

Cracks or Ruptures in the Albumen Coat are sometimes produced by drying the print too rapidly. Dry slowly at ordinary temperatures.

§ 3.—Collodio-Chloride.

Fading is said to be owing to the use of albumen as an understratum.

Bad Tones.—Citric acid in collodion. Substitute tartaric.

Slow Toning.—Repellent collodion. Moisten the plate before immersing in the toning solution with equal parts of alcohol and water.

Flat, weak Pictures.—Insufficient quantity of pyroxyline in collodion. Omitting to fume when fuming is needed.

Sunk-in Prints.—The cotton may not be suitable.

Splitting of Film.—Neglect to edge the plate.

Spots.—According to Mr. Simpson, the discoverer of the pro-

cess, spots are caused by—1. Too much free nitrate of silver in the collodio-chloride. 2. Keeping the plates too long after coating. Dry before a fire and expose at once.

Crystallizations in the Film.—Excess of nitrate of silver in the collodion. Add more salting.

Insensitiveness.—Insufficient quantity of nitrate of silver, more will be needed.

Detaching of the Film (from paper in the collodio-chloride paper process), want of sufficient sizing in the paper. Few or no papers have the necessary quantity, and a coat of gelatine is usually necessary.

Rolling up of the Prints.—This is an annoying peculiarity of the process, and difficult to avoid. It is said that plunging for an instant into very hot water will destroy the tendency.

Blue Tones.—The toning is much more rapid than with albumenized paper, and unless care is taken, the print may be over-toned before the operator is aware.

Final Observation.—In closing this chapter on Failures, which the writer has endeavored to make as complete as possible, he feels compelled to remark that whilst the sources of non-success are almost innumerable, none do anything like so frequent and fatal damage as *want of care and of perfect cleanliness*. The commonest sources of trouble are—

1. Use of insufficiently cleaned vessels.
2. Immersing of fingers into solutions, which fingers have been in other solutions without intermediate washing.
3. Tables slopped with solutions, which thus adhere to the bottoms of bottles, measuring glasses, beakers, &c., so that when these are poured from, a fatal drop runs along the outside from the bottom and mixes with the other materials. A drop of hypo-sulphite solution will spoil almost any other chemical solution with which the photographer works. All these sources of trouble have this in common, that they introduce foreign matter into the photographer's materials unknown to him, and this is the most frequent of all causes of failure.



CHAPTER XV.

OUT-DOOR PHOTOGRAPHY WITH WET AND PRESERVED PLATES.

§ 1.—Wet Plates.

IN Chapter VII. most of the information necessary for view-taking has been given, nevertheless some special details remain to be noted.

When negatives are to be taken at a distance from the dark room, we are obliged either to work with a tent, to use "preserved plates," or to resort to "dry plates," which last method will be considered in subsequent chapters.

Although plates are apt to deteriorate pretty rapidly by keeping after sensitizing, yet, with care and attention, remarkable delays may be supported, especially in cold weather. Heat hastens the destruction of the plate. Since the first edition of this Manual went to press, the writer has paid particular attention to this subject, and has succeeded in keeping wet plates in a very satisfactory way. His method will be found below.

The following are the troubles which will be apt to show themselves:—

1. Fog.
2. Marbled stains. (See also p. 327.)
3. Transparent or hazy spots of various sizes up to one-quarter of an inch diameter, generally nearly round.

Fogging is not a very common trouble, and seems to depend on newness of collodion, for which a riper must be substituted.

Marbled stains are very apt to come, especially in hot weather. After a careful study of these sources of trouble, the writer advises as follows:—

1. Use a rather ripe collodion containing a liberal proportion of bromides (from $2\frac{1}{2}$ to 3 grains of bromide to 4 of iodide), and immerse the plate into the sensitizing bath as soon after coating as possible. In hot weather just as soon as the drops cease to fall.

2. Adopt the excellent system of having two negative baths,

one to make the film, 35 or 40 grains to the ounce, and the other 20 to 25 grains to the ounce, exclusively reserved to pass the plates into after the film is completely made to the first. Thus the plate is always covered with a comparatively fresh, pure bath solution. This is an excellent plan for general adoption; but when the plates are to be kept long, it is indispensable.

3. Withdraw the plate as soon as the oily marks are gone.

4. Apply thick wet blotting-paper on the back. This must not be *too* wet, or it will make stains by running down the back of the plate and getting round the bottom and irregularly diluting the liquid on the film.

5. But the most important precaution of all lies in avoiding accumulation of bath solution. For this purpose, the writer, after draining the plate thoroughly on successive pieces of folded blotting-paper, and wiping the back thoroughly, sets it in the frame, of which the corners have been carefully and thoroughly wiped out immediately before. A piece of the thickest blotting pad has been provided, about an inch wide and as long as the plate. On the long side of this a narrow edge, about an eighth of an inch wide, is folded over at right angles. This strip is laid along the bottom of the plate, but the chief peculiarity of the arrangement is that the plate is lifted up to the *narrow edge passed under it*. This edge is not to pass between the face of the plate and the glass corners, *but under the bottom edge of the plate*. It thus comes just into contact with the bottom edge of the collodion film, which it keeps steadily drained during the whole delay. This has a really wonderful influence in preventing *marbled stains*, for which it is a perfect cure.

By operating in this way, the writer has been able to keep plates with facility and certainty for an hour, and even much longer. On one occasion a plate was carried twelve miles, and developed at the end of nearly two hours (1 hour 55 minutes), and gave an excellent negative. No preservative was applied, and the success depended upon the foregoing precautions, of which a second bath of weaker and purer solution, and the blotting pad under the edge, were the most effective. Plates kept for two and a half hours gave hazy spots, but were free from all other faults. This mode of operating the writer strongly recommends.

The *hazy spots* are very annoying and troublesome when the delay is very long; difficult by their size to touch out, and ruining the picture if left in. They appear to arise from a concentra-

tion of the bath solution reacting upon the iodide of silver in the film. The presence of acid, especially of *nitric acid*, has seemed to the writer to increase this tendency. For plates that are to be kept, acetic acid is better than nitric. The addition of a few grains of acetate of potash or soda, with a little acetic acid, will change a bath from a nitric to an acetic bath. The proportion is roughly about a grain to five or six ounces of bath. Dissolve in half an ounce of water and pour slowly into the bath, stirring. The cloud of acetate of silver at first formed will speedily disappear.

Tripods.—See Chap. VII., sec. 3.

Tents and Boxes.—When the distance of the object makes it clearly impossible to carry a wet plate, we must either use a dry one, or else take the means with us for preparing wet plates on the spot.

In using a *tent*, the operator works inside. With a *developing box*, he passes his arms through sleeves provided with India-rubber rings, and watches his operations through yellow glass let into the front of the box. Of the two methods the former is the more satisfactory. With the box there is more danger of spilling hyposulphite, and so exposing the delicate operations of photography to the effects of hyposulphite dust.

Of tents, probably Carbutt's is as convenient as any. A still more convenient mode of operating is with a *van*, either altered or built for the purpose. Mr. G. W. Wilson, the well-known Scotch photographer, recommends a very light tripod covered with two thicknesses of black calico and an inner one of yellow. The calico is a foot longer than the tripod, on which extra footstones are placed to steady the tent and exclude light. There is probably nothing better than this simple and convenient plan. The tripod may be very light, and of course folds up into a small space, so that the whole weight, including that of the cover, is trifling. An umbrella has been found an excellent support for a tent; it is secured to a stake driven in the ground, and an opaque cloth thrown over it; a piece of yellow muslin set in, lets in light enough to work by, and water is introduced from a vessel outside by a flexible tube. An exceedingly convenient arrangement has been made by altering an old barouche, the front part being arranged with an operating table and racks for bottles, the photographer sitting on the back seat to sensitize and develop.

Where the object is rather lightness than folding up into short

lengths, three pieces, or four if preferred, of cane-angle may be fastened together at one end and a cloth thrown over them.

Any of these plans seem preferable to the more elaborate sort, which are heavier to carry, and require the loss of valuable time to put them together and get the whole concern into working order. It is to be remarked, both with this plan and that of the tripod, that the wider the stride given to the legs the steadier the whole arrangement.

Shortening the Out-door Work.—Various plans have been found useful to cut short the development and postpone the fixing (also a redevelopment, if needed) until it can be conveniently finished in the dark room at home.

The first plan used was to flow the plate with glycerine to which a little water had been added, but this has given way to the *syrup treatment*. A filtered mixture of clear syrup molasses and water is provided, and as soon as the development is over, the plate is carefully flowed with it, and in this condition may be kept for a day or two. Mr. Gulliver makes a decoction of saffron in water, to be used in the same way, and lines the top and bottom of the plate box with wet felt. Some, in using syrup, add alcohol, as follows:—

Syrup molasses	10 ounces.
Water	10 “
Alcohol	6 drachms.

The plate is then slid into a groove in a light tight box of wood or tin. It must be well washed before redeveloping.

‡ 2.—**Instantaneous Photography.**

When objects in motion are to be photographed, it becomes necessary that the exposure should be so reduced that the movement shall be inappreciable. To these exposures the name of “instantaneous” has been applied, although they are in many cases reduced to a small fraction of a second. Various contrivances have been devised for effecting them. The most usual and one of the best is to have a slide attached to the camera front, capable of moving up and down in a groove. In its centre is a circular opening of an inch or two in diameter. When the slide is up or down it covers the lens, but in descending it uncovers it for the space of time that the circular opening takes to pass the front of the lens.

For exposures which, though brief, are to be longer than those attained as above described, the cap may be removed and instantly replaced. This is best done by raising the lower part whilst the upper part is held nearly still, almost like turning upon a hinge. In this way the foreground gets a much longer exposure than the distance and sky. Another method is to let the focussing cloth hang over the uncapped lens; the palm of the hand is placed over the lens, and the corner of the cloth held between the thumb and the lower part of the forefinger. The hand being then turned upwards over its own back edge as an axis, uncovers the lens for a moment and is instantly returned, in both cases carrying the cloth with it. As in the former case, this exposes the foreground longer than the sky.

The conditions under which instantaneous pictures are to be taken differ extremely. Widely extended views throw back a great volume of light and much facilitate the operation. Ships at sea, with breaking waves, offer no very serious difficulty, if the size of the plate is not too large. River scenes, with sail boats and steamboats, are similar in character. Instantaneous views of these subjects will be best taken with the Steinheil aplanatic or the Dallmeyer rapid rectilinear, remembering always that the shorter the focal length the more powerful the image, and that success is thereby very greatly facilitated.

On the other hand, objects in motion near by, sending back comparatively little light, no matter how brightly they are illuminated, will be most easily managed with a portrait lens. But as this lens has comparatively little depth of focus, care must be taken to get the objects pretty nearly into the same plane; and as the corners will be very apt to be out of focus, it may be necessary to vignette the negative in printing.

The Chemicals.—The bath should be forty grains to the ounce, new or nearly new, and nearly neutral. The collodion should be just old enough to work, and, what is of special importance, must be made of cotton of a very sensitive character. Cotton capable of giving intense images that need no redevelopment, does not possess the exalted sensibility necessary for instantaneous work; we need a cotton of a very impressible character, and this is usually accompanied by a tendency to form images needing redevelopment. Without a suitable cotton, it will be hopeless to attempt the work. The developer must contain no restraining acid, and be simply an eighty-grain solution of sulphate of iron.

The development must be very brief, or such a developer will produce fog.

The subject must not present difficulties too great. The illumination must be good everywhere, and there must be no strong contrasts. Objects in motion will be much more easily taken when their line of movement is either towards or from the operator. An object passing rapidly, directly in front of the camera, will be exceedingly difficult to catch successfully; it is, however, accomplished.

Instantaneous views are most easily obtained in the spring, at which season the light is more active than at any other. Therefore those who especially interest themselves in this branch of work find it desirable to accomplish it in May and June.

It is a not uncommon mistake for those who desire to have a "quick acting collodion," to seek for it in some special formula. This is all a delusion. A highly sensitive collodion is one made with a *highly sensitive cotton*. As for the formula of salting, a few trials of different proportions of bromide must determine what is best suited to it. But what suits one specimen may not suit another. One way is to make with the cotton a collodion containing but little bromide (as, for example, by Reutlinger's formula, p. 142). If on trial it seems sensitive, make up another portion by a formula rich in bromide, and compare these, and one or two mixtures of each, in different proportions.

Mr. Chapman recommends after the iron development has done all that it can, to wash it off and to apply an alkaline development with pyrogallie acid (see Chap. XVI.); when this ceases to act, to finish with acid pyro and silver in the ordinary way.

The writer has found that a very material acceleration can be obtained by lining the inside of the camera with pasteboard which has been colored red with carmine dissolved in water with the aid of a drop or two of ammonia. This pasteboard is not to line the whole of the inside (see Fig. 107, p. 220), but only those parts where the light is least strong—opposite ground and trees, but not sky.

The red rays of light have a *continuing*, but no exciting power. They, therefore, exalt the action of the image upon the plate, and, when rapidity is an object, this method will be found decidedly advantageous.

Animals.—Very beautiful photographs are obtained of horses, dogs, cattle, &c. In order not to risk motion of the subject, it is

best to make very brief exposures, simply uncapping and instantly replacing the lens. A quarter-size portrait lens is the most suitable. If larger pictures are desired, it is best to take the small size just mentioned and to enlarge afterwards. This is the method adopted by Mr. Schreiber, of this city, who makes this subject a specialty, and who has shown the author of this manual some very fine enlargements, taken from quarter-plate negatives. He prefers to take even small animals, such as dogs, in the open air, with appropriate surroundings, rather than under the skylight.

‡ 3.—Preserved Plates—The Glycerine Process.

The preserved plate stands intermediate between the wet and the dry. Of various preservative processes, the glycerine and honey, first brought prominently forward by Mr. W. H. Harrison, is the best. A plate coated and sensitized as usual is plunged without previous washing into a bath prepared as follows:—

Price's glycerine	2 ounces.
Pure honey	2 “
Ordinary bath solution	2 “
Water	2 “
Glacial acetic acid	8 drops.

These are well shaken up and set in the sun for a few hours, or still better, a day, then half an ounce of kaolin is added, well shaken up, and the whole, after standing for a day, is filtered into a bottle. A large funnel with a filter in it is left permanently in the neck of the bottle. When wanted for use, a sufficient quantity is to be poured into a pan. After using it, it is poured back into the funnel; it is a saving of trouble to have the funnel large enough to carry the whole at once; the mixture is then always through and ready for next day. The glycerine keeps the filter moist and ready to filter well and rapidly.

The sensitive bath is a common acetic bath, a bath acidulated with nitric acid does not work well. The usual formula for the glycerine preservative does not include the acetic acid as above, but the writer has found a marked advantage from adding it.

As above directed, the preservative bath contains about eight grains of nitrate of silver to the ounce. By use it becomes continually richer in silver, and thereby deteriorated—from eight to ten grains is its proper dose. Therefore we must add glycerine

and honey, and if necessary a little water from time to time to maintain a correct proportion. After such addition it must invariably be sunned and shaken up with kaolin again.

The *development* of these plates takes place in the ordinary way with an iron developer or with a pyrogallic one. In the former case, an exposure about three times as long as for wet collodion is proper. With a pyrogallic development a longer exposure is needed; this mode is preferred by Mr. Harrison, as allowing of more latitude in exposure. The writer's trials have worked best with iron development; for this purpose he does not like the plain iron developer so much as the sugar developer. (See p. 164.) The development is generally best done in a pan. The edges sometimes become a little dry, especially if the plate has been kept six to twelve hours; and then these do not take the developer evenly, and the edges may be defective even when all the rest of the plate is good, unless developed in a pan. A red transparent sky indicates over-exposure.

This method will, when well managed, give results about as good as ordinary wet work, but scarcely up to the best wet work. It has no great capacity for mastering contrasts, because over-exposure causes a deep red solarization, obliterating every trace of detail. It is, therefore, necessary to be extremely careful to avoid over-exposure. It is probable that this process would work well with a collodion containing bromides exclusively. Filtration before each using is necessary. No under-stratum is required.

It seems exceedingly probable that the introduction of glycerine into the negative bath would enable us to obtain plates that would keep for a long time, especially if the method of two baths be adopted, the glycerine used in the second one.

CHAPTER XVI.

DRY PLATE PHOTOGRAPHY.

BEFORE describing specific processes, the writer proposes to give such manipulations as belong to all dry work, and which need not be repeated in connection with individual processes.

Formerly it was held that only second-class work could be

done with dry plates. But it is now established that soft and delicate negatives, full of half-tone, can be made on dry plates, and that in place of the tedious and exaggerated exposures needed by the older method, dry plates can be made as rapidly as wet.

§ 1.—Preparation of the Glass.

It will be desirable to clean the glass by the bichromate process already described. Before receiving the coat of collodion, they should have an edging of India-rubber dissolved in benzine.

Procure some fresh clean India-rubber, wet the blade of a knife and pare off the outside and reject it. Cut the rest into very thin strips, put about a quarter of an ounce of it into half a pint of good benzine; common benzine will not answer at all, but a pure specimen is needed. Shake up well, and in a few days solution will take place. This solution may be diluted by adding twice its bulk of benzine; it is then ready for use. (It is said that moistening the strips of India-rubber with chloroform will aid the solution.) The writer has always succeeded in making the preparation without this aid.

Tie a camel's-hair pencil to a glass rod of medium size a little way from the end. Take a wide-mouthed four-ounce vial, and into the cork make a hole that will just receive the glass rod. Into the vial put the diluted rubber solution to the depth of half an inch. Push the glass rod down so that when the cork is in, the rod will touch the bottom. (See Fig. 132; the rod should project about ten inches above the cork.)

Fig. 132.

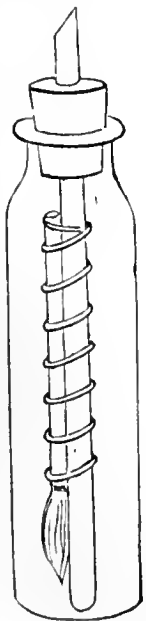

When ready to begin, take a plate, hold the glass rod against its edge so that the brush will press on the face of the plate. Draw the rod round, and thus make a neat border an eighth of an inch wide round the plate. Edge half a dozen plates in this way, and set them in a rack to dry (they dry immediately) before beginning to coat.

Many sorts of dry plates *blister*—that is, the solutions penetrate the film and get between it and the glass, raising the film into blisters. It is best, therefore, to leave the corners open, so that this may have a fair chance to run out, or rather; it is better to carry the coating along the longer sides, but leave a break at the ends of the

shorter side. This allows the liquids to drain easily out of the breaks in the edging. (See Fig. 133.)

With plates larger than $6\frac{1}{2} \times 8\frac{1}{2}$, however, or when the films show themselves tender, it is an excellent precaution to varnish the edges just before developing, as well as before coating. This double application gives great steadiness to the film, without interfering with the escape of any liquid which may have worked through. The writer has often saved plates in this way which would undoubtedly have split without the second edging.

Some edge the plates after exposure, but the protection afforded is inferior by very much, and the trouble fully as great. Some use albumen as an under-stratum for the whole plate; the method of doing this has been described at page 155. Others use an under-stratum of thin solution of India-rubber over the whole plate, which plan the writer does not think well of.

The writer recommends always, when possible, to prepare dry plates *at night*, because at that time the windows can be kept raised enough to thoroughly ventilate the room, and so diminish the injurious effects of the fumes of collodion.

Fig. 133.



§ 2.—Drying.

Thorough drying is necessary for dry plates, and may be effected by *spontaneous drying*, by *heat*, or with *sulphuric acid*.

Heat.—A 4-sided vessel is made of sheet-copper, in shape a truncated pyramid. A ledge at bottom keeps the plate in its place. The vessel is half filled with water, and heat applied from below. If the water is boiling, or nearly so, the plates will be safely dry in twenty-five to thirty minutes. They should always stand five or ten minutes to drain before the heat is applied. Irregular surface markings, which at one time caused the writer considerable annoyance, he succeeded in tracing to this cause, and they at once disappeared wholly by taking the precaution of letting the plates stand and

Fig. 134.

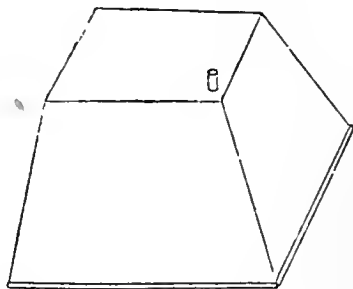

drain. The hotter the drying temperature the longer the plates should wait.

Drying by Sulphuric Acid.—The writer believes that much of the difficulty experienced in making good dry plates depends upon the method of drying. The slow, even drying obtained by placing the plates in a tight box with a pan of sulphuric acid, as recommended by him many years ago, gives a remarkably even and perfect plate, and he uses it exclusively.

Drying Box.—After planning and having made several sorts of drying boxes, all of which proved unsatisfactory, the writer has contrived that shown in the adjoining figure, and which, after full trial, has seemed to him to leave nothing to desire.

The box (Fig. 135) has the front hung on strap-hinges so that it turns entirely over and rests on the top, as shown in the figure.

Fig. 135.

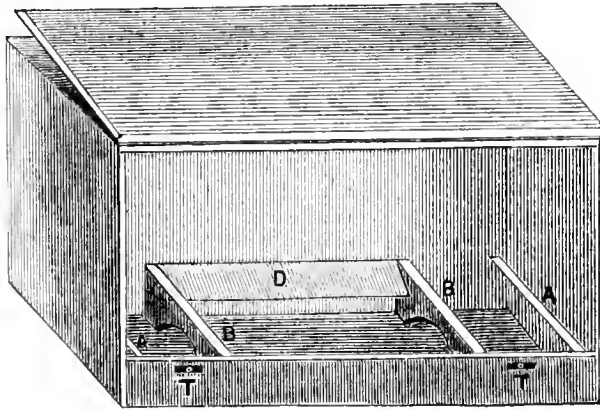
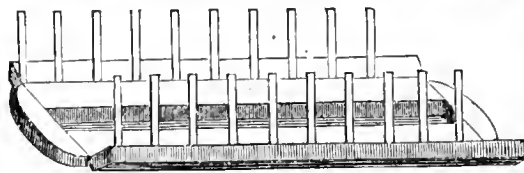

Fig. 136.



When brought down, it closes upon a rebated edge, and is secured by the turn buttons T T. About five inches from the bottom are placed at each end the cleats A A, and at the same level, the bridges B B. On these four pieces the rack (Fig. 136) slides in, and when the front is brought down and secured, the rack is perfectly protected from light. A small door, D, permits the pan, containing about a pound of sulphuric acid, to be slid in. This door opens outwards, not inwards, as represented in the cut, by an error of the engraver.

The rack (Fig. 136) is constructed as shown in the section (Fig. 137). B B are two long strips of light wood, into these are mor-

tised cuttings of thick plate-glass about half an inch wide, over a quarter thick, and about seven inches long. These are laid with the flat side against B and are mortised in, but not fully, so that when the outside pieces, A A, are screwed against B B, they hold the glass firmly in its place, and leave spaces, E E.

Between each two glass uprights, these spaces, E E, extend all the way to the top. On the pieces A A, strips of glass, C C, are cemented.

If the reader will carry the construction of this section over to the full view (Fig. 136), he will see that every sensitive plate, when set in, is supported in *six* places, and yet touches nowhere anything but glass. It leans back on the two uprights behind it, at the lower front edge it touches the two uprights in front of it, and near its corners it touches the outside edges of the glass strips, C C. It is consequently held very securely, and also the drainings are conducted away at four different points from each plate. As the back of the plate rests against two points only (the tops of D D, Fig. 137), the backing can be applied as soon as the plate is out of the sensitizing bath, and the back and front thus dry together, saving much handling.

In Fig. 136 the rack contains, for simplicity, ten pairs of uprights, accommodating nine plates. In the box used by the writer there are twenty-five pairs, accommodating two dozen plates of any size, from half-plate up to 8×10 . In fact, this form of rack has the advantage that it will support any size of plate, and if the box were of suitable dimensions, would contain plates from half-size up to 10×12 , or larger.

If the box is not kept in the dark room, it should have a thick black cloth cover. The writer usually leaves his plates in the box thirty-six hours before using them, in order to insure perfect drying in every part.

A simpler but less compact mode of making a drying box is simply to take an empty box, set a pan of acid in the bottom and a range of empty tumblers round the sides. In each tumbler set the lower corner of a plate, and let the upper rest against the side of the box. Cover up securely from light and from change of atmosphere.

Fig. 137.

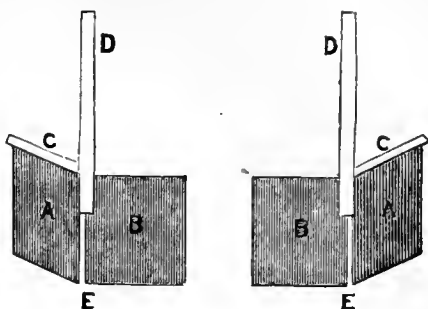

Drying spontaneously is effected in a dark cupboard, or even on shelves in a dark room. Drain the plates for a minute or two, not more, on blotting-paper, and then set them in the cupboard, each with the lower end resting in an empty tumbler, its upper corner against the wall. Some allow the plates to dry on blotting-paper; this has the disadvantage of keeping the lower end very long in drying, and so risking unequal action in development.

‡ 3.—Backing the Plates.

Dry plates are almost always more transparent than wet ones, so that the tendency to internal reflection is greater than with wet plates. The result is blurring, otherwise called "halation," and its effect is that the high lights work into the adjoining shadows. Thus the foliage adjoining the sky is more opaque than it should be. Roofs of buildings shade off towards the sky. Boughs of trees, when bare of leaves and projected against the sky, are especially apt to become blurred, as the light works in on both sides. These effects are ruinous to the work, so that it becomes advisable always to coat the backs.

After much careful study, the writer has finally come back to *annatto* as combining, on the whole, more advantages than any other substance with which he is acquainted. It is, however, essential to use glycerine with it, or the whole coating will gradually become everywhere penetrated by fine cracks. Quite a small proportion of good glycerine will wholly remove this difficulty. The writer uses *two fluidrachms* of thick syrupy glycerine to the quarter pound of annatto in lumps. A convenient way of managing the mixture so as always to have it ready is the following:—

Provide a half-pint porcelain bowl with cover and handle (to be obtained from a dealer in chemical utensils). Put into it a quarter pound of annatto with a little more water than necessary to cover it, and set aside for several days. The annatto will soften, and can now be easily worked into a smooth paste. Add two fluidrachms of glycerine and work it well in. This mixture, if kept closely covered, will keep good for weeks, and if too thick can be thinned by stirring in water. As the quantity diminishes, add more weighed annatto in lumps, taking care to add also the proportionate quantity of glycerine. The additions

of glycerine are always to be proportionate to the quantity of annatto added, and not to the water. This last will, of course, be added when needed; the mixture should, however, form a pretty thick paste, and is to be put on liberally.

The writer has examined many other mixtures. *Gum* may be colored deeply by aniline brown or other suitable pigment. To prevent cracking, sugar must be freely added, so that the quantity of sugar will be nearly up to that of gum, say in the proportion of three to four by weight. But the annatto is preferable, and in practice does not cost more, as it goes much further.

A round bristle brush as thick as the thumb will be found convenient for applying the paste. Bring it up to within a quarter of an inch of the edge all around. It should be thick enough not to run: annatto has much less tendency to run than mixtures of gum, and this is no small advantage.

When plates are dried by sulphuric acid or spontaneously, the backing may be put on as soon as they are out of the preservation bath. In drying by heat this cannot be so well done, at least the heat has a tendency to liquefy the backing and make it run down.

The character of the coat when dry should be carefully tested. Not only should it show no tendency whatever to crack, but it should resist perfectly when tried with the thumb-nail. Even, however, if the coating appear perfect when examined from the back, it may have separated in places from the glass sufficiently to be no longer in *optical contact*, and from that moment it is perfectly useless. That it is then useless not only follows from theoretical considerations, but is abundantly proved by experience, as the writer has seen in his own work. If a dry plate, after thorough drying, be examined in the dark room, catching the reflection upon the film side, it should have a perfectly even coloration and a certain dark look all over. If it appears here and there lighter in spots, then in these spots the backing is no longer in optical contact, however perfect it may seem, and the film at these spots is unprotected and liable to blur if any cause of blurring be present.

Before developing, sponge off the back thoroughly with cold water.

§ 4.—Acid or Silver Development.

This is conducted in precisely the same way as the pyrogallic development of an ordinary wet plate, except that the silver is added very cautiously, so as to avoid too rapid a deposit upon the high lights. The acid development of dry plates has, however, almost wholly given way to the

§ 5.—Alkaline Development.

This method shortens the exposure to one-half or one-third, giving at the same time softer and more harmonious effects.

The first idea of using alkali for the development of dry plates originated with Mr. Borda, of Philadelphia. The next steps in it were made by Mr. H. T. Anthony, of New York. These gentlemen were undoubtedly the discoverers of the principle of alkaline development. Subsequently it was taken up in England, and gradually brought into its present shape by Mr. Glover, Mr. Leahy, and especially Major Russell, who made the discovery that the development might be controlled and restrained by adding a few drops of solution of bromide of potassium to the alkaline developing bath. This last discovery has given us the means of managing the whole operation at pleasure, and producing every variety of negative, from the most veiled to the most transparent.

Management.—Prepare the following solutions: Pour some alcohol into an ounce vial of pyrogallic acid, and filter the solution into an eight-ounce vial, washing the filter with alcohol until the vial is full. This gives a solution of nearly 60 grains to the ounce.

Take 6 ounces of good clean flinty carbonate of ammonia, and pour over it enough warm water (not hot, hot water decomposes it) to cover it. After standing an hour or two, filter into a quart (32-ounce) bottle, add more water to the undissolved residue, and so on until the whole is dissolved in the 32 ounces. This gives a solution of about 80 grains to the ounce, which must be kept well corked.

Dissolve bromide of potassium in water in the proportion of 60 grains to the ounce.

In commencing to develop a lot of plates, put into a small vial half an ounce of the 60-grain bromide solution, and three-

quarters of an ounce of 80-grain carbonate of ammonium, and mix well by shaking.

Next, for a whole size ($6\frac{1}{2} \times 8\frac{1}{2}$) plate, take a 7×9 porcelain pan, and put into it 4 ounces of water. Add $\frac{1}{2}$ drachm of the solution of pyrogallie acid, and immerse the plate so as to wet it equally and avoid lines of unequal development when the alkali is added.

Now remove the plate and add to the bath 15 to 20 minims of the mixture of bromide and carbonate, mix, and return the plate. The image should rapidly come out, and when its details are well out, add, without waiting longer, half a drachm of the carbonate of ammonium solution. Density rapidly comes, and when the plate has reached printing strength, fix it as an ordinary wet negative. Except that with plates made with a collodion containing bromides only, the fixing bath must be very weak, one part of hyposulphite to fifty of water.

Heat in Development.—The water used in making the developing bath should never be cold, but rather of the temperature of 70 to 80°. A higher temperature than this is very useful in case of under-exposure. If in the development of a plate it is evident that it has been considerably under-exposed, and there are other plates that have had a like exposure, it will be well to develop them in a bath at about blood-heat, or even a little warmer. This will be found to aid materially in getting out the image, and will often save plates that would otherwise be lost. A little more bromide in the developer will be advisable when it is used hot.

Acid Development to Finish the Alkaline.—In the writer's experience, it is always best, if possible, to finish the plate wholly by the alkaline development. The results are softer and more harmonious, and the shadows more luminous. Some, however, prefer only to bring out a thin image, and then finish with pyrogallie acid and silver. The writer does this only when, from a material under-exposure, it is impossible to get printing density without it. It should, however, be very clearly understood that in such cases it is better to resort to an acid development than to push the alkaline under circumstances that lead to fogging.

If the alkaline development stops entirely (if it even goes on very slowly, it is best to let it take its time), it can generally be started again by adding a little more carbonate of ammonium. But, after carrying this addition to a certain point, it is best to

stop. The writer does not find any good effect, but rather mischief, result from raising the proportion of carbonate over one and a quarter, or at most one and a half, grain to the ounce.

If, then, the addition of carbonate has reached this point, and the development has quite ceased, it will be well to redevelop with acid. The first thing needed is to wash the plate under the tap, to get the alkaline liquid out of it, which, in contact with silver solution, would cause instantaneous fog. Meantime, sufficient water is placed in a clean basin, and acetic acid (No. 8) is added in proportion of about one-twelfth of the water and mixed by agitating. Into this the plate is put, that the acid may remove the last traces of alkali before the silver is applied (if the plate is put into the acid solution without previous washing, bubbles of carbonic acid gas may form under the film and detach it, as the writer has seen happen). Pyrogallic acid and the usual solution of silver (nitrate of silver 10 grains, citric acid 15 grains to the ounce) are added in very moderate quantities to the bath.

§ 6.—Failures in Dry Plate Operations common to Dry Plates generally.

Dry plates are much more exposed to accidents than wet, partly because the latter remain in the sensitive stage so short a time and are used at once. There is also in dry-plate work a greater need of strict cleanliness. Any operator, for example, who ever, under any circumstances, places hyposulphite in any vessel used in any of the operations other than fixing, actually invites failure. The least trace of hyposulphite in the developing pan will cause the development to fail. A pan that has been once used for fixing must never be used in any of the other operations, neither as a water pan for soaking the plates before the preservative nor for any other use whatever. Each pan must have its special use, and be reserved for it.

Again, dry plates must never be exposed to the air, especially not the air of a work-room, which may have in it gases of various sorts. The plates, both before and after fixing, must remain in tight boxes, perfectly excluding air and dampness, for all dampness is destructive to dry plates. And as to gases, the vapor of acetic acid, which is often in the air of the dark room, tends to destroy the latent image. Sulphur vapors of any sort tend to fog.

Another source of trouble lies in wet tables. The bottles or

other vessels resting on the wet take up some, and when turned over to pour from, a drop or two from the bottom may run along the outside and fall unnoticed along with the contents.

Keeping.—Although many sorts of dry plates show good keeping qualities, yet their sensibility in most cases slowly diminishes, so that plates a month old should have full one-half more to double the exposure of fresh ones. Also, the image, after exposure, tends to fade in the delicate details; it is, therefore, commonly said that the golden rule of dry-plate work is to develop as soon as possible after exposure. The same evening is the best time of all, but generally two or three days' delay will not be very important. For longer delays a longer exposure should be given. But it is to be carefully borne in mind that, quite apart from fading, the longer a plate is kept after exposure the more it is exposed to adverse influences of all sorts.

Errors as to Length of Exposure.—This is a serious source of difficulty with dry plates. With wet, the first plate tried gives a clear idea of the character of the day's light, and the rest are measured thereby. But with dry plates, all on any one excursion must be exposed on a venture, and there is no criterion from the first to the rest. Fortunately, there is a good deal more latitude with dry plates than wet, and in exposing, it is best to err on the side of too much rather than too little. Certain points are of consequence to remember.

1. After midday the light soon falls off, and about three hours before sunset, at some irregular time, the diminution begins to be very considerable.

2. In the beginning of September the light is already materially weaker, and a great allowance must be made for its failing. October, compared with May or June, will need about a triple exposure.

3. Cloudy days, excellent for soft effects, are often deceptive as to strength of light. With very thin clouds, the light is sometimes extremely powerful. With a grayish color in the clouds, the light is much weaker.

4. Sheltered places, partly under trees, receive a great deal less light than open ones; the difference is so much greater than appears, that such views are extremely apt to be under-exposed.

The Ratio of Exposure, compared with wet plates, varies with different sorts of dry plates, but it must never be forgotten that the proportion of exposure increases always as the light is fainter.

Thus, a dry plate which in a good light needs a threefold exposure, will in a poor light need four or five times the exposure of a wet plate in the same light, and in very dull, rainy weather will scarcely receive any impression at all.

Non-actinism of the Film varies greatly with different processes, so that in changing one's process, one is apt to be deceived. Two plates by different processes, looking equally dense, will probably differ very much in the printing.

Irregularity of Surface before Developing.—This peculiarity the writer has been able to trace to the use of too strong preservative solutions. Some films will hold in them much more solid matter than others, and what they will not retain in them of the solids dissolved in the preservative bath solution must come up to their surface in drying. Merely thinning a collodion with alcohol or ether may cause it to give a thinner film, so that the preservative in use can no longer be held wholly in the film. Use more pyroxyline or weaker preservative, and wash such plates before developing them.

Image, after advancing awhile, goes back.—Too much carbonate of ammonium, which never should exceed one and a quarter grain to the ounce of developing bath.

Fogging.—Same cause. Also, too much pyrogallie acid. Exposure of plates to deleterious gases. Pushing too far the development of under-exposed plates. Using pans that have had hyposulphite in them.

Want of Detail in Shadows.—Under-exposure. Too much bromide used in the development. Insufficient development.

Surface Stains.—Drying by heat without allowing to drain five or ten minutes before applying the heat.

These stains, like the irregularity explained above, may depend upon the preservative. If the preservative solution be pretty strong, and collodion not a full-bodied one, the film, as it contracts in drying, may not be able to hold all the dry preservative, and thus this will be forced up to the surface in places as it dries, and dry in superficial stains. The coffee process is subject to this difficulty. Remedy: Change the collodion or dilute the preservative.

Want of Intensity.—Bad pyroxyline. Under-exposure. Over-exposure may produce same result. In the latter case the whole picture flashes up—in the former the high lights come easily, and the rest very slowly.

Stains.—Insufficient cleaning. Handling with dirty hands, or touching the plate at all.

Dampness.—Exposure, even temporary, to dampness, gives rise to more or less decomposition of the sensitive film, resulting in insensitiveness and other troubles. The writer *invariably*, in all weathers, wraps his slides in waterproof black cloth, using a piece sufficiently large to cover them with several folds. Another piece, about four and one-half feet square, is again wrapped over this; the latter serves as a focussing cloth also. Slides, even when so wrapped, should never be laid on the ground or on damp stones. In a word, every precaution must be taken to insure dryness before and after exposure.

Transparent Dots and Filamentous Marks.—Dust in the preservative solutions, or falling on the plates in the slides or in the camera.

Blistering.—This annoying trouble depends upon the pyroxyline. Often the sorts otherwise the best, blister badly. Leaving open places in the edging, that the water may wash out, is the best remedy. (See Fig. 133, p. 353.)

Mistakes in Exposing.—Nothing is more vexatious than to expose by mistake a second time a plate that has been already used. Every dark slide should have a number plainly painted on it, and the slides should be exposed in the order of their numbers. Those who find a tendency to mistakes of this kind may render them impossible by pasting a strip of paper, one end to the slide and the other to the shutter. The exposure cannot be made without breaking or cutting the strip previous to withdrawing the slide, and thus the condition of the strip indicates at once whether the slide has been exposed or not.

Accidental Uncovering.—If the slides are carried far, and much jarred or bolted, the shutters will sometimes slip aside and uncover one end of the plate.

With single dark slides the writer always has a small flat hook attached to the slide and fastening to the shutter handle. With double slides this cannot so well be done, and the best way is to tie twine round them.

Noxious Fumes.—Any reducing vapor or gas must destroy plates. Sulphuretted hydrogen, or any foul emanation from drains or water-closets, chemical vapors of many sorts, probably also carbonic oxide, the so-called "gas" that comes from badly drawing stoves. Sulphurous acid would also destroy plates.

Resinous wood used for drying-boxes or for plate-boxes, or freshly-varnished wood surfaces would be very suspicious.

It will be observed that all of these sources of trouble point amongst other things to the necessity of the complete exclusion of external influences. And this can, perhaps, in no way be better effected when plates are to be carried to any distance, and preserved for any time, than by inclosing the cases in thick brown or dark green or red paper, saturated with India-rubber varnish. Where this cannot be procured commercially, it might easily be made by the photographer himself. The joints of the paper must, of course, be pasted down with the varnish also.

CHAPTER XVII.

DRY PROCESSES.

IN the foregoing chapter the writer has endeavored to group together those details that are common to all dry processes. Therefore, before undertaking any of the following methods, it is presumed that the photographer has made himself acquainted with its contents.

In learning any one dry process a step will have been made towards all, so much have they in common. At the same time they are nevertheless very distinct. The best advice that can be given is to hold persistently to some one process until it is completely mastered. Then, if desired, others can be experimented with, with the view of settling down upon some one. It is an important matter to be able to judge by the inspection of a dry plate whether it has the right density and modulation to print well. This can scarcely be done if the photographer changes about, because some dry plates are very non-actinic, whilst others, equally dense to the eye, are comparatively very transparent to the chemical rays. Hence much changing will lead to continued mistakes in development.

As, in the writer's opinion, the collodio-bromide process gives the most sensitive plates and the softest negatives, and as these plates are the most easily and rapidly prepared, it will be placed first.

§ 1.—**Collodio-Bromide Dry Process.**

The first idea of adding nitrate of silver to a bromised collodion, and of thus dispensing with the negative bath, originated with Messrs. Sayce and Bolton, and was by them put into a practical and workable shape. After several years of constant use and experiment, however, the writer has been enabled to greatly increase both the rapidity and the certainty of the process by radical changes made in every part of the mode of proceeding, viz., by introducing aqua regia into the collodion, by adding the nitrate of silver in a state of solution, and also by changing the preservative. The tedious washings are done away with, and a better and more sensitive plate is made with greatly diminished trouble and manipulation.

The Pyroxyline.—For collodion to be used in this process, a very intense cotton is desirable. The best course is to obtain specimens from two or three sources, of cotton believed to be intense, and to try them, securing a good supply of that which answers best.

Formula for Collodion.

Ether	2 ounces.
Alcohol	1 ounce.
Bromide of cadmium	15 grains.
Bromide of ammonium	3 “
Pyroxyline	21 “

The two bromides should be placed together in a test-tube or flask, and dissolved in part of the alcohol, with heat if necessary. Previously dissolve the pyroxyline in the ether and rest of alcohol. Set the bottle in a light warm room, where the sun will fall on it for several hours a day. It will be fit for use in three weeks, and be good for three or four months, after which the film is more apt to be weak, that is, to split in washing.

Aqua Regia.—Put into a stoppered bottle an ounce of ordinary hydrochloric acid and half an ounce of ordinary nitric acid. Stand in a warm place; as soon as the mixture takes an orange color, remove it and keep it well stoppered.

Gum Solution.—Several different preservatives may be used, but in all the best, *gum* makes an essential part. It should be dissolved and kept in quantity. Upon one-quarter pound (avoir-dupois) of good clean gum-arabic pour six or eight ounces of hot

water, stir well, and, after a portion of gum has dissolved, pour the liquid on a filter, add more hot water, and continue till the gum is got in solution in thirty ounces water. Take an equal quantity of clear white sugar (one-quarter pound), and dissolve this in portions in the gum-water before filtering. After filtering, add about two-thirds of a drachm of carbolic acid, and the mixture will keep for a year in perfect condition.

As gum-water is very slow and troublesome in filtration, it will be well to use a *percolator*. (See Part V., Chapter II.)

Sensitizing the Collodion.—Measure out into a graduate as much collodion as is expected to be wanted, and add to each ounce, in hot weather, two drops of aqua regia. The easiest and safest way to drop it is to plunge a glass rod in the acid bottle, and let drops fall from the end into the collodion.

Weigh out ten grains (10 grains) of finely powdered nitrate of silver (fused is best, but crystallized will do) for each ounce of collodion taken, and place it in a small flask. Measure some 95 per cent. alcohol in a graduate, allowing a quarter of an ounce to each ounce of collodion taken. Pour about half of this into the flask upon the nitrate of silver, warm it over a Bunsen's burner or other gas flame, agitating gently all the while. As soon as the alcohol boils, remove it and continue to agitate. In a few moments return the flask or tube to the lamp till boiling recommences. In this way most of the nitrate will dissolve; this is poured into the collodion, and the operation is repeated with some more of the alcohol, leaving a little for a third application. All of the silver will thus be easily got into solution.

The addition of the nitrate solution to the collodion should be made in the dark room; all the previous operations may be conducted by ordinary light. In adding the nitrate solution, a little should be poured in at each time, shaking a little between each. The hot solution should not go down the sides of the bottle, but straight into the collodion. On the sides it might chill and crystallize a little.

Most of the nitrate dissolves in the first portion of the alcohol; as soon as this is all in the collodion, shake up well for a couple of minutes. After adding each following portion, half a minute's shaking will be ample.

A long narrow vial is preferable for this operation, and should not be more than about half full, otherwise the shaking will act

less effectually, and must be continued longer. It is a good plan to keep the bottle rolled up in yellow paper, to exclude all light.

After the last addition has been made, and the contents shaken, the bottle is to be put aside. Too much shaking is more likely to do harm than good.

The mixture should stand for a time that depends somewhat upon the temperature of the room and the season, and may vary from ten hours to sixteen. It is then ready for use as soon as filtered.

No more should be made than is intended to be used up, and the residues should be rejected. If kept over about sixteen hours, there is no certainty of the working of the plates, whereas, when made as here directed, they are more uniformly successful, and free from fog and stains, than are wet plates.

Filtering.—Before using, the sensitive mixture will need to be filtered through a bit of clean sponge forced into the neck of a funnel. This should neither be put in too tight nor too loose, the collodion should run through in a very thin stream, or a rapid succession of drops. The mixture filters quite as easily as plain collodion, the bromide of silver in suspension being apparently entirely without effect upon the filtration. In addition to the sponge, the writer likes to use a linen filter. A yard of the finest and closest linen is boiled for a few minutes in a gallon of water, with an ounce of common crystallized carbonate of sodium. It is then thoroughly washed out with clean water, and left to soak, then well wrung out with clean water. This furnishes a large number of excellent collodion filters, and one has more certainty of getting films free from specks when this is used in addition to the sponge.

Coating the Plate.—More care is necessary than in ordinary coating, as the collodion has more tendency to set unevenly. Pour on in the same way as usual, but without sending back to the far corner, put on plenty, cover the plate rapidly. *Raise the far end of the plate as little as possible*, just enough to enable the surplus to drain off. Keep it so, and rock steadily. In ordinary coating, at the end of the draining we raise the plate almost vertically: this is exactly what is not to be done here, the plate is kept almost horizontal until the collodion has set.

Operating in this way, if we do not get an even plate the mixture is too thick and will require to be diluted. This may be done either with plain collodion or with ether. Generally the

former is the best; but it must be plain collodion made with the same cotton: this is essential. In hot summer weather the sensitive mixture is much more difficult to manage, and will sometimes need the addition of ether before it will work smoothly.

It is impossible to judge of the character of the plate by holding it between the eyes and the light. But if held *a little to one side* of the light, every slightest inequality will become conspicuous. A perfect plate will look perfectly smooth, but plates that show only a slight irregular cloudiness will give perfect negatives. If the cloudiness reaches a certain point, it will be liable to show in the flat tints, sky, water, &c. When the cloudiness reaches to a still greater extent, it is liable to produce *mottling*, which shows especially in the skies.

Before proceeding to coat the plates, they will need to be *edged*. (See p. 352.) As the coating should not instantly follow the edging, it is best to edge half a dozen or a dozen, and stand them in a rack. Each plate, before coating, should be carefully brushed with a broad flat brush, and a piece of folded paper should be interposed between the fingers of the left hand and the under side of the plate, or else a pneumatic holder should be used.

As soon as the plate is set, it is thrown into a pan of water and lies there until it no longer shows greasy marks when taken out, but exhibits a perfectly uniform surface. It is best to have three or four pans of water, and coat a plate for each in succession, agitating the pans gently from time to time. As soon as they cease to show greasy marks and are smooth, they are ready to transfer into the pans of "preservative." In these they remain from five to eight or ten minutes, at the convenience of the operator. The time is not very material, provided it is not less than five minutes nor much over ten.

If the plates are not to be dried by heat, they may be backed at once. The plate is taken out of the preservative bath, reared on end, and the back wiped with blotting-paper, because if the wet is left on, it thins the backing too much. The colored paste (see p. 356) should be as thick as possible to manage; it is put on thickly and carried up to within an eighth, or, at least, a quarter of an inch of the edge.

If they are to be dried by heat, the backing, if applied first, will be apt to liquefy and run.

When plates are to be dried by heat, they should drain five or ten minutes before the heat is applied, or *surface markings* may be expected.

Preservatives.

Almost any preservative that can be used with common dry plates made with a bath, can be used also with collodio-bromide plates.

The writer of this manual has devoted a great amount of time to investigating the qualities of a great range of substances as preservatives. He finally adopted two as being superior to any of those previously proposed or used. These are, first, *pyrogallic acid*; and second, a special preservative made from *cochineal*.

Pyrogallic Preservative.

The writer uses for all purposes in which pyrogallic acid is employed, a solution made by pouring alcohol into an ounce bottle of pyrogallic acid till it reaches the neck. A bottle holding just 8 ounces (or marked with a diamond on the side at the point to which 8 ounces fill it) is adopted for regular use, and the above strong solution placed in it. More alcohol is poured into the original pyrogallic acid bottle to rinse it, and this is poured upon the filter and so on, till the filtrate amounts to 8 ounces. This is the simplest mode of operating and avoids all waste of material, as both the bottle and filter are well washed out. Shake well to mix the different portions.

To make the pyrogallic preservative, take

Of above solution	1 drachm.
Of gum and sugar solution, already described (p. 365)	10 drachms.
Of water	6 ounces.

In making a batch of plates, it is convenient to prepare three such baths to save time, as the plates are rapidly worked through. Each plate, as soon as set, is slid into a pan of water; as soon as the oily appearance is gone, it goes into the preservative bath, and then in five minutes is ready for drying. Both the water pans and the preservative pans should be occasionally agitated a little by lifting one end and letting the liquid pass in waves over the plate.

The writer has never been in the habit of making more than

six or eight plates in one bath. Using three baths, and making a batch not exceeding two dozen plates, there will have been eight to each bath.

If the plates are to be dried without heat, it is always most convenient to back them as already described, as soon as they are out of the preservative bath.

Cochineal Preservative.

Grind one and a half ounce of good clean cochineal in a mortar with one fluidounce of fuming sulphuric acid. As the paste gets gradually thicker, add more acid, until in all two fluidounces have been added. When well mixed, transfer into a wide-mouth bottle, wipe the neck clean inside, set in a vessel of hot water, and leave till cold. Let it stand for a week, then pour out into about a quart of water. Add slaked lime until a piece of litmus paper dipped into the solution turns blue. Then filter and pour water upon the filter until the filtrate amounts to eighty ounces. Add a quarter of an ounce of carbolic acid, and the mixture will keep indefinitely. As but little of it is needed, one making such as the above will be sufficient for a season's work.

To apply it as a preservative, take of the above

Solution	6 drachms.
Gum and sugar solution (p. 365)	10 “
Water	6 ounces.

This, placed in a pan just large enough to hold a plate of $6\frac{1}{2}$ by $8\frac{1}{2}$, will make a convenient bath for that size of plate; or the quantity may be increased or diminished for larger or smaller sizes.

As to the choice between these two excellent preservatives, it is not easy to decide. The cochineal gives very dark, blackish plates; the pyrogallie acid, light brown, not unlike wet plates. The cochineal gives the softest, the pyrogallie acid the brightest negatives. The writer has had much more experience with the cochineal, having used it exclusively for view-taking through an entire season, and with great satisfaction. He has kept plates as long as three and a half months in good order.

The pyrogallie preservative he has only discovered much more lately, and cannot as yet report upon its keeping qualities. Judging by analogy, they ought to be excellent.

Either of these processes, by increasing the dose of bromide in

the development, will give more and more contrast and absence of deposit in the shadows, so that it is easy in this way to give the negatives an ambrotype appearance. For a soft printing negative this is not desirable, but this property might be useful in making *transparencies for the lantern*, for which the pyrogallic process seems particularly applicable—more so than the other.

Other Preservatives for the Author's Collodio-Bromide Process.

As already said, almost any preservative that will work with a common dry plate is suitable for collodio-bromide plates. Next in order of excellence to the foregoing the writer places the *Tea preservative*, first proposed by Mr. Newton. This preservative is undoubtedly superior to tannin, to coffee, or to gallic acid.

In the writer's hands, tea has worked better without gum and sugar than with them. It is sufficient to take a tablespoonful of good black tea, let it infuse in boiling water in a covered cup in a warm place for an hour or two, filter and dilute until the liquid amounts to eight ounces. As before, the plate, as soon as the water has rendered it smooth and uniform, is put into this bath for five or ten minutes, and then backed and dried. The results are good, but distinctly inferior to the foregoing.

Coffee Preservative.—Make a decoction of an ounce of coffee in eight of water, and filter. This preservative does best with gum and sugar. To the above quantity, an ounce and a half of the gum and sugar solution may be used.

Tannin.—In the use of tannin a great mistake has been generally made by using too much of it. The writer prefers—

Good tannin	16 grains.
Gum and sugar solution	10 drachms.
Water	7 ounces.

This is about one-eighth as much tannin as generally directed, and gives much softer and more harmonious pictures. If a deficiency in brightness and density is found, increase the tannin.

Exposures.

For the author's preservatives, two first described, give with a good light the same exposures as for wet plates; with an inferior light, the exposure must be longer than for the wet. For the tea plates, give once and a half as long as for the wet. For the coffee and tannin plates, give twice as long as for the wet.

It will be observed that through all these various treatments the writer's collodio-bromide process gives much greater sensitiveness than is attained with the ordinary dry processes used with the same preservative.

For Drying, see p. 354.

For Development, see p. 358.

§ 2.—Dry Plates made with a Negative Bath.

This is the older way of managing dry plate work, and for those who habitually use the wet process, and occasionally need a dry plate, it is the more convenient. It is also preferred by many habitual dry-plate workers.

For this method of dry-plate work the regular negative bath suffices, though it is an advantage to have it a little more acid. Ordinary collodions may be used if they are pretty old; generally they are improved by adding a little simply bromised collodion to them, or a grain or two of bromide of cadmium to the ounce.

But they will work still better with a very intense cotton, giving a porous and not a skinny film. If made specially, the collodion may be salted as follows:—

Iodide of ammonium	2 grains.
Iodide of cadmium	2 “
Bromide of cadmium	3 “

Add a little tincture of iodine and keep in a warm light room for several week. If the pyroxyline has a good deal of intensity, it may be used sooner, but age and ripeness have much to do with success in dry plates.

The plate should be edged with rubber solution, as described at p. 352, remembering that the collodion must not be poured on till the edging is dry. When set, the plate is to be slid into a pan of water until the greasiness disappears, and is next to be washed thoroughly under the tap until all free nitrate of silver is removed. It is then plunged into the bath of preservative, whichever it may be intended to use, and is finally backed and dried, or dried first and backed afterwards.

The preservatives have been already described pretty fully under the head of the collodio-bromide process, and the manipulation is much the same in both cases, except that, in the present case, the work is much more laborious. The collodio-bromide

plate was put into the pan of water immediately after coating, whereas the present sort must first be sensitized in the nitrate bath. Again, the collodio-bromide plate goes direct from the water-pan into the preservative, whereas the ordinary dry plate requires a thorough washing under the water faucet to be interposed between these two operations.

Thus it requires twice the time and trouble to prepare an inferior and less sensitive plate.

Pyrogallic Preservative. See p. 369.

Tea Preservative.

Tannin Preservative.

Coffee Preservative.

} See p. 371.

CLOVE PROCESS.

The writer has found that a preservative of cloves gives most excellent plates. Clove nuts, not the ground cloves, are taken and broken up. Over a quarter pound, pour a quart of hot water, and, after some hours, filter. To seven ounces of water add one ounce of this decoction and one hundred grains of gum. Treatment in all respects the same as with tannin.

A decoction of *Malt* is with some a favorite process.

RESIN PROCESS.

Despratz first showed that if common rosin, or some other sorts of resin, be added to the collodion, the plates need no preservative, but may be simply washed and dried, after going through the negative bath. At first the process was much objected to on the ground that it rapidly deteriorated the negative bath. But it appears that this may be easily restored to working order by adding a thirty-grain solution of permanganate of potassium until the bath retains a faint reddish coloration; then filter and acidulate. The collodion should be of an intense character and porous structure, and to it is added two grains to the ounce of common rosin, or one grain rosin and one grain Canada balsam. After passing through an ordinary nitrate bath, wash it thoroughly. It is advisable to use distilled water for the first and last washings. The plates are more sensitive when newly prepared than after keeping.

Development same as tannin; or a weak iron development.

MORPHIA PROCESS.

By Bartholomew. Said to be more sensitive than many other processes. Proceed exactly as in the tannin process, but make the preservative bath a solution of *acetate of morphia*, one grain to the ounce. The writer has found it advantageous to add to the bath acetic acid No. 8 (Beaufoy's), two or three minims to the ounce. Plates keep only from five to twelve days.

GUM GALLIC PROCESS.

Gordon recommends for collodion:—

Alcohol and ether, each ½ ounce.
Iodide of cadmium 3 grains.
Bromide of cadmium 3 “
Iodide ammonium 1 grain.
Pyroxyline, not over 6 grains.

Negative bath forty grains. Leave in ten to fifteen minutes; plunge into two successive baths of distilled water; leave two hours in a third. Or use four successive pans.

Preservative Bath.

Water (warm) 8 ounces.
Gum-arabic 160 grains.
Sugar candy 40 “
Gallic acid 24 “

It is advised to apply a substratum of albumen, and, before developing, to edge with India-rubber. Probably edging at first with India-rubber would be sufficient.

Development may be either alkaline (managed as in the tannin process), or an iron developer containing two grains of gelatine to the ounce of developer may be employed. The gelatine should be first dissolved in the acetic acid. A redevelopment with acid pyro and silver is needed. Fix in hyposulphite. Exposure three times as long as for the wet. Should the alkaline developer veil, use more bromide in it, adopting the proportions given for collodio-bromide plates.



CHAPTER XVIII.

NEGATIVE VARNISHES.

IT is of the very highest importance to the photographer to obtain a varnish as nearly perfect as possible. Upon it he must depend for the preservation of all his work, and it would be difficult to adequately describe the losses that some have suffered in consequence of trusting their negatives to varnishes of a defective character.

This consideration, and the very contradictory nature of the opinions held by good judges, have led the writer of this manual (although fortunate enough in his own case never to have used a bad varnish) to undertake a very thorough and careful study of the subject within a short time past. The results which were reached proved not only very important, but were to a considerable extent contrary to opinions which have obtained general acceptance, and which had been up to that time entertained by the author himself.

Five different varnishes formed the subject of this study, each one of a sort that has been highly recommended. One was a *bleached lac varnish*, two were of *unbleached lac*, one of sandarac; these four were spirit varnishes. To these was added a *benzole varnish*, and as the writer has never been in the habit of making benzole varnish for his own use, a commercial benzole varnish was selected, of a high character and largely used. The four spirit varnishes were made by the following formulæ:—

No. 1.—*Bleached Lac Varnish.*

Bleached lac, best quality	9 ounces.
Sandarac	3 “
Essence lavender	5 “
Alcohol	69 “
Filter.	

No. 2.—*Unbleached Lac Varnish.*

Orange lac, best	220 grains.
Sandarac	80 “
Essence lavender	$\frac{1}{4}$ ounce.
Alcohol	4 ounces.

All the ingredients mixed at once.

No. 3.—*Unbleached Lac Varnish.*

Best orange lac	200 grains.
Alcohol	4 ounces.
Dissolve, filter, and add	
Sandarac	80 grains.
Essence lavender	1½ fluidrachm.
Filter again.	

No. 4.—*Sandarac Varnish.*¹

Sandarac	10 ounces.
Canada balsam	1 fluidounce.
Essence lavender	2 ounces.
Alcohol	64 “

No. 5 was the commercial benzole varnish before mentioned, and of which the writer has not the formula.

These varnishes were applied on waste negatives with heat before and after, and exhibited the following characteristics:—

Smoothness.—Nos. 1, 3, 5, perfectly smooth; 4 was somewhat thready and more difficult to work; 2 a little irregular, but less so than 4.

Clearness.—Excepting that 5 showed a very slight tendency to dry dead, all were perfectly clear.

Hardness.—This important quality was tested by rubbing steadily with a moderately soft lead-pencil, in one place, until the film was cut through, and noticing how much resistance each exhibited. It was found necessary to make this test with great care, as one and the same film varied much in different parts, resisting best always where the image was densest (because there was more varnish absorbed and retained there). It was, therefore, necessary to choose a portion of each of equal density, and to repeat the trial many times to avoid error. Result: No. 4 the hardest and No. 5 the softest by a good deal, the rest intermediate. No. 3 was harder than 1 and 2, evidently because of the more sandarac and less lavender. It was estimated that No. 4 resisted four times as much friction as No. 5; that No. 2 was half-way between. No. 3 was intermediate between 2 and 4, and No. 1 was next in softness to No. 5.

Resistance to Heat.—The amount of resistance to heat exhibited by a varnish is of very great importance. In our hot summer weather negatives in the direct rays of the sun may become

¹ For this formula the writer is indebted to Mr. Fennemore.

greatly heated. It is a fact well established in physics, that glass allows the heat rays direct from the sun a much freer passage than the dark rays returning from an object beneath the glass. Therefore there is a tendency for the heat to accumulate in the film, paper, and packing, and thus to subject the varnish to a most severe trial. If it softens in the least, adhesion of the paper takes place, and the negative may easily be destroyed.

In order to subject the varnishes in question to a decisive test, they were placed on a metal vessel filled with hot water, and heat was applied below till the water boiled. From time to time slips of paper were pressed forcibly upon the varnished surface, and then were gently raised to observe if the slightest adhesion took place.

One curious result observed was that when the heat was moderately raised, Nos. 1 and 2 showed signs of slight adhesiveness, which, when the heat was raised higher, instead of increasing, entirely disappeared. This evidently indicated that, in applying heat immediately after varnishing, the heat had not been applied long enough to drive off all the essential oil. So that when, in this experiment, a considerable heat was applied, the remaining essential oil softened the resins, but presently evaporated, leaving the film more solid. This shows how much depends upon a thorough application of heat after varnishing.

It was found that, as all these varnishes were good, a higher degree of heat than that which could be obtained by boiling the water in the vessel was necessary to decide as to the superiority. Therefore fresh pieces were taken, cut from the same negatives, and these, without a gradual heating, as in the former case, were suddenly placed upon a piece of iron so hot that a drop of water let fall on it instantly boiled away. This high heat brought out the differences in a very decisive way. Nos. 4 and 5 were still almost wholly free from any tendency to stickiness. Nos. 1, 2, and 3 did decidedly less well.

Resistance to Moisture.—When varnished films crack and break away in progress of time, this evil generally results from dampness penetrating the film. Under its influence the collodion film would naturally swell, the varnish not, and this unequal action tends to detach the film from the glass and crack the varnish. As this action generally requires years to become apparent, it was thought that the most expeditious, as well as severe, test of

resistance to moisture would be made by plunging the negatives under water.

Accordingly pieces of the same size in each case were cut out of negatives varnished with the different varnishes, applying the same quantity, as nearly as possible, of each, and drying by equal heat. These were placed side by side in a large deep porcelain pan and kept covered with water.

At the end of *four days* No. 5 gave way; the rest were all in good order.

They were examined from time to time, and all appeared perfectly sound, until, at the end of *six full weeks*, it was noticed that Nos. 1 and 3 showed a very slight puckering at one corner, as if there might be a commencement of detaching. Nos. 2 and 4 appeared to be in as good condition after six weeks' immersion as they were before they were placed in the pan.

The writer cannot but consider this result very remarkable. It indicates that, with several of the varnishes of which the formulas are here given, the action of moisture amounts virtually to nothing.

To sum up: If we examine which of all the varnishes exhibited the greatest number of good points, we shall find it to be the much condemned sandarac varnish (No. 4). It was the *hardest* in resistance to mechanical injury, one of the two best *resisting to heat*, and one of the two best *resisting to moisture*. Its only fault was a tendency to threadiness when applied, requiring a little more dexterity to make a good even coating.

The benzole varnish did not stand high at all, its only good points being its *resistance to heat*, in which it was equalled by the sandarac, and in hardness, in which it was excelled by the same. In resistance to moisture it was very far behind all the rest.

The two orange-lac varnishes (Formulas 2 and 3) exhibited good qualities. Number two resisted moisture for six weeks as well as the sandarac. Both were easily applied, and gave smooth, even films without trouble. But they were deficient in hardness, and their resistance to heat, though fair, was inferior to Nos. 4 and 5.

In view of these objections to the lac varnishes, and of the very poor resistance of the benzole varnish to moisture, the preference must evidently be given very decidedly to No. 4, the sandarac, a most excellent varnish.

Varnish is generally best left to clear itself by standing. It quickly clogs a filter, especially if it contains lac.

Varnishes will dissolve some collodions, it is said, though the writer never saw this happen. In such cases it is recommended to add about one or two per cent. of water. The addition of water, even to a small extent, will often diminish the solvent powers of the alcohol for some of the constituent parts of the varnish, and cause a cloud to form, rendering filtration necessary, and perhaps changing the character of the varnish. It should, therefore, never be done unnecessarily.

In view of the results of the above careful examinations, there would be no advantage in giving additional formulæ for other and comparatively untried varnishes, when qualities so excellent have been proved to exist in some of the foregoing.

The highly polished surface of a heat-dried negative does not easily take color or shading. In addition to the methods already given for overcoming this difficulty, it may be mentioned here that *finely powdered resin*, rubbed on the part of the film to be operated upon, has been found to be an excellent treatment.

CHAPTER XIX.

TREATMENT OF RESIDUES.

EVERY photographer should endeavor to avoid wasting the valuable metals that he employs, but the extent to which this care should be carried will depend largely upon the scale on which he carries his operations. It would be, for example, a waste of time for the amateur to attempt to extract the silver from his hyposulphite solutions, but the professional photographer should never reject them without first removing the silver, unless indeed he operates upon a very small scale. But the amateur will always wish to recover the silver from baths, positive and negative, that have become useless.

Residues may be worked in two ways, either the dry or the wet. Both are chemical manipulations of the very simplest order, can be explained in a few paragraphs, and can be readily mastered by any man of ordinary intelligence. The writer would

recommend the professional photographer to use the dry way, and the amateur, the wet.

§ 1.—The Dry Way.

Old Baths.—These will be thrown down with common salt. Take good coarse but clean salt, make a strong solution of it in any convenient vessel of glass or wood. Pour in the baths with constant stirring. Make sure that the salt has been added in excess, or large quantities of silver may be wasted unknowingly. To make this certain, let the whole have a most thorough agitation, then let stand some hours to settle, take off some of the supernatant liquid, and add to it a little clear solution of salt. If no precipitate falls and no cloudiness is produced, the operator may feel assured that all the silver is thrown down as white chloride of silver, changing to violet whenever exposed to the air.

This chloride must next be washed. The liquid over it is carefully and completely drained off, clean water added in abundance, the whole thoroughly well stirred up and allowed to settle, then poured off, and this is repeated several times; the oftener the better. The vessel should be capacious, so that the chloride of silver, after settling for some hours, should not form a layer extending one-tenth the height of the water in the vessel. (It should be carefully borne in mind that if any hyposulphite baths are poured into this, that, so far from anything being precipitated from them, the hyposulphite will dissolve large quantities of chloride of silver, if this has been already thrown down, or *prevent its precipitation*, if added earlier.)

The chloride of silver, after being washed and dried, is put into a crucible, after being mixed thoroughly with half its weight of dry carbonate of soda and one-quarter its weight of clean sand. The crucible should not be plunged suddenly into a hot fire, or it will almost surely crack. But a few live coals should be put into the furnace, then a thin layer of fresh coal, then the crucible on that, and more fresh coal heaped round it. Bring the fire gradually up to a bright red heat, and when the silver is melted, stir it up with an iron rod. The most suitable crucibles are of Paris clay, to be had of the dealers in chemical apparatus. Common sand or "Hessian" crucibles are porous: if these are used, they should have the pores filled up beforehand by fusing a little borax in them, to prevent the silver from sinking in.

Cuttings and Spoiled Prints.—These should be carefully burned in any convenient vessel, the ashes gathered up, and these may be added to the foregoing. Some have advised to heat the ashes with nitric acid, but this does not exhaust all the silver, and the nitrate of silver obtained is too impure for use without reducing it.

Hyposulphite Baths.—The silver is best extracted from the old fixing baths, positive and negative, by precipitation with liver of sulphur (sulphide of potassium). The silver is thus thrown down as sulphide of silver. This sulphide of silver is a heavy black powder, from which the sulphur is recovered by melting with an equal weight of saltpetre. But in doing this, two precautions must never be omitted.

First, the sulphide must be heated red-hot *by itself* (that is, before the admixture of the saltpetre) in an iron pot. The object of this is to burn off the sulphur powder thrown down along with the sulphide of silver, and which, if it remained with the sulphide of silver when melted with the saltpetre, might cause dangerous explosions.

And secondly, it is necessary to be certain that the whole of the sulphide of silver is decomposed. This may be materially aided by stirring the mixture after it has been some time fused, with an iron rod, and continuing this for some time.

The writer, believing that all photographic operations should be carried on with nitrate of silver of the best quality, not only advises not to mix the silver got from the sulphide with that reduced from the chloride, but either to dispose of it to a refiner for further purification, or else to purify it by dissolving it in nitric acid, and adding this solution to the spent baths, to be with them precipitated as chloride. Many will doubtless hold this to be excess of caution, but a bath, and especially all negative baths, ought to be beyond suspicion.

Gold-Residues.—The least troublesome way of managing them is undoubtedly that recommended by Davanne, to acidulate the spent toning baths; add thereto solution of persulphate of iron, and to add the precipitate obtained by the addition of the iron solution to the chloride of silver, and place them in the crucible together. Then the lump of silver contains the gold alloyed with it, and, when the silver is dissolved in nitric acid, the gold remains behind.

The residue containing the gold, after nitric acid has dissolved

all that it can dissolve, is a dark-colored powder, which may be treated with hot nitro-hydrochloric acid (nitric acid one part, hydrochloric acid two parts), in which it easily dissolves.

§ 2.—The Wet Way.

This method is here recommended chiefly for amateurs who wish to work over their positive and negative baths. A gallon precipitating jar is to be about one-third filled with a solution of clean salt, and the baths are turned into it and thoroughly stirred up. After the chloride has settled, and leaves the liquid clear, a portion of it is placed in a clean glass, and tested with more solution of salt, to make sure that the precipitation is complete. After being well washed by repeatedly stirring up with water, and pouring off again, the water is finally poured off closely, a little sulphuric acid is added, and then a lump of good zinc. For each pound of silver an ounce of sulphuric acid and a half-pound of zinc will be ample. The chloride rapidly shows signs of blackening, and this slowly proceeds until the whole of the metallic silver is revived in the form of a grayish-black powder.

At the end of about two days, during which the contents of the vessel should be occasionally shaken, the operation will be complete. The lump of zinc is removed, a little more sulphuric acid is added, stirred up, and the whole left for some hours. The revived silver is then washed precisely in the same way as the chloride, with eight or ten waters (first breaking it well up with the fingers), and is then ready to dissolve in nitric acid. To effect this solution, place a quantity of nitric acid of good quality in a vessel of which it does not fill over one-fifth or one-sixth. Throw in the silver powder, waiting between each addition till the effervescence subsides, and avoiding *most carefully* to inhale any of the red fumes evolved; to which end the operation should be performed under a well-drawing chimney. When all the silver is dissolved, the solution, which is always very acid, is to be filtered, evaporated down, and either crystallized or fused; the writer decidedly prefers the latter.

In fusing nitrate of silver, care must be taken to use a sufficiently large porcelain basin; for if, when the solution is very much concentrated, it reaches nearly to the edge of the basin, it is liable to perform what is known to chemists as "travelling"—that is, it will creep over the sides, and a crust once established,

more and more will get over by capillary attraction, make a crust on the outside, and run down, half crystallizing and half fused, upon the table. The writer once left a capsule with nitrate preparing for fusion, for a short time, and, on returning, found over half a pound outside. Capsules of Berlin or Meissen porcelain only can be trusted for fusing nitrate of silver.

This method of operating gives satisfactory results if carefully carried out. The zinc used should be pure. The Bethlehem zinc, sold in the Atlantic cities of America, is excellent for this purpose. Granulated zinc is not near so good for use as zinc in lumps, for, though it may work a little faster, there is always danger of small portions being overlooked and remaining in the silver, failing to be dissolved by the acid. The Bethlehem zinc comes in ten-pound ingots. Instead of granulating it, set it on a good fire till it is nearly ready to melt at the corners; remove it, and it will be found that, when thus hot, it will break up under a hammer with the utmost facility.

With many photographers it will be an object to have as little to do with chemical manipulations as possible. Such cannot do better than to sell their residues to some fair-dealing reducer. The residues should be kept in good condition, and the three sorts kept separate, viz., chloride, from throwing down old baths with salt; sulphide obtained from fixing baths by precipitating with liver of sulphur; and lastly, ashes from clippings, failures, etc.

CHAPTER XX.

PHOTOGRAPHY ON GLASS AND ENAMEL, AND COLLODIO-CHLORIDE PRINTING.

§ 1.—Printing on Glass by Development.

POSITIVES may be obtained on glass in a variety of ways, both by development and sun-printing, and each different method has its advocates, and is capable of giving good results. These positives, when made on ordinary transparent glass, are known as *Transparencies*, when printed on white opaque glass they are known as opal pictures or *opalotypes*. The difference depends

solely upon the material used as a support, and either may be obtained by development or by the direct action of sunlight.

When made *by development*, two different methods may be employed. An image may be obtained in the camera, and be subsequently developed, or the negative may be laid on the sensitive plate and exposed to a weak light, and followed by development.

Printing in the Camera.—When it is intended to print in the camera, by far the best method is to have a camera expressly constructed for this purpose, with two bellows and two racks and pinions. Suppose the bottom of an ordinary camera to be extended in front, another camera to be attached, and beyond, a frame to receive the negative. In this way a *total exclusion* of diffuse light is effected; no ray can reach the lens except through the negative. The frame containing the negative at the front can be racked in and out, as also can the dark slide and focussing screen at the back; the lens occupies a stationary position between the two.

In Fig. 138 the portion A receives the dark slide in the usual manner. B is similar to the front of an ordinary camera; it carries the flange, and into it the lens is screwed. At N is a special

Fig. 138.

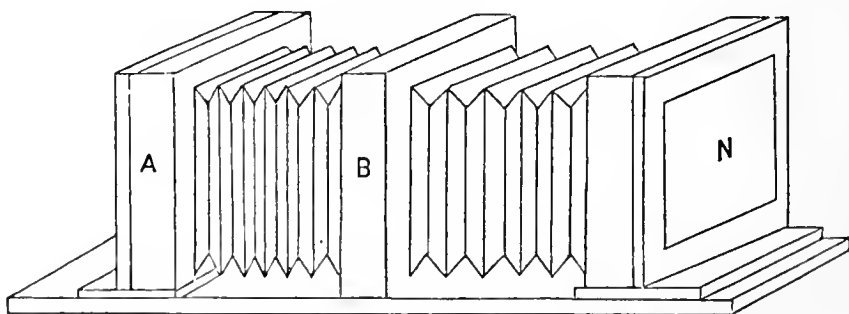

arrangement to receive the negative which is to be printed. The front, N, is raised and pointed at a bright cloud, or a mirror may be placed in front of it, inclined so as to send light from the sky directly upon the negative, and the focussing is done by racking the back, A, in or out. The space from A to B is shorter than from B to N, because the centre of the tube of the lens (which projects beyond B towards N) should correspond with the middle of the base-board. To copy a whole size plate of equal size with the original, the space from A to N must be fully four times the focal length of the lens employed. A ten-inch Steinheil aplanatic will be useful for the purpose. In this case the space from the

negative frame to the focussing glass should be from three feet six to four feet. B is stationary. A and N rack backwards and forwards. If the photographer has two cameras of suitable size, they may be combined so as to give very much the effect of the double camera, shown in the figure. The second camera has its lens removed, its front is turned towards the front of the other camera, and the end of the tube of the one is thrust through the flange of the other. The ground glass is also removed, the negative to be copied is secured in the focussing frame in its place.

Or the arrangement represented at Fig. 139 may be used. Four strips of wood extending from the camera support a light

Fig. 139.

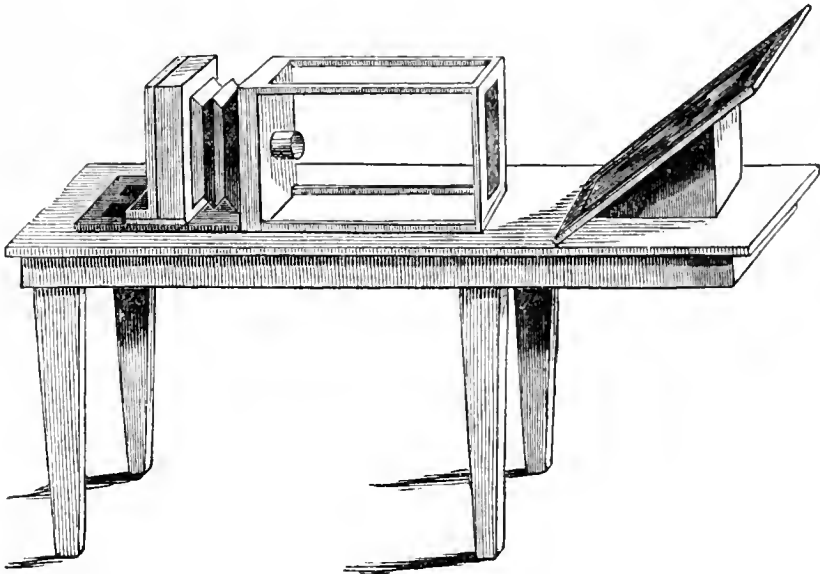

frame, in which the negative is to be secured, and during the operation the space between the camera and the lens is covered over with a piece of black muslin or a focussing cloth. A mirror placed in an inclined position throws light through the negative. The object of arranging the legs as shown in the figure, is to admit of pushing the portion supporting the mirror outside of a window, in order to receive light direct from the sky above. The same object may be attained by nailing a board of the proper width and length upon an ordinary table, and making it project at one end in the same manner.

The larger the size of the transparency, in proportion to the original negative, the greater must be the distance between the ground glass of the camera, and the frame holding the negative. It has been already said, that when the copy is to be of the same size as the original, the distance will be approximately four

times the focal length of the lens when focussed on a distant object.

The transparency will need to have the same brilliant clearness as the negative, which will be got in the same way—a full exposure, a rapid development with plenty of restraining acid, and fixing immediately.

It is scarcely necessary to say that the negative for this purpose must have precisely the same properties as those intended for enlargement (see p. 177.) It must not be dense; print must be easily legible through the densest parts. The deep shadows must be represented by clear glass, free from all trace of veiling.

Contact Printing followed by Development.—Transparencies may also be obtained by the wet process without the use of the camera. A wet plate is prepared in the ordinary way, and after *thorough* draining, strips of thin letter paper are laid on its face near the edges where it is not important to get the image, and the negative is laid face down on these, which preserve it from actual contact. It is then held for half a minute or thereabouts, according to the density of the negative, under an argand burner, and development is effected in the usual way. A dense negative will not answer.

The treatment of the positive after development will depend upon the object in view. If the object be to produce a picture to be viewed in the stereoscope or hung against a window, the plate after fixing will be blackened with corrosive sublimate, or, better, will be treated with iodine and then with sulphide of potassium. (See p. 171.)

If the intention is to produce an enamel by Grüne's process (which see), the plates will be toned with bichloride of platinum.

The same results as the above are got by using a dry plate, exposing under the negative in a frame for a few seconds to diffuse daylight, or for about a minute under an argand gas-burner, or to magnesium light; the latter being the most certain, as when the quantity of magnesium required for one operation has been once determined, it is easy to repeat without danger of error.

Transparencies for the Magic Lantern, or "Stereopticon," may be made in several ways. Contact printing on wet collodion, as just described, may be used, or they may be printed on the camera, as above, or dry plates may be used; the latter method was habitually employed by a photographer who for a long time supplied most of our dealers with lantern slides. Equally good

results are got by wet collodion. In any case the lights must be perfectly transparent. A long exposure, rapid and very acid development, quick fixing, and then a treatment with corrosive sublimate, followed by cyanide of potassium or sulphide of potassium, will be suitable. (See p. 172 for details.)

The Albumen Process.—The albumen process, which was used for making negatives before the discovery of the collodion method, and which was superseded by it, gives finer transparencies on glass than any other method in use. A good deal, however, depends upon the personal skill of the operator. It was, for example, long believed that Ferrier's magnificent specimens were produced by some secret process of his own, but eventually it appeared that he used the regular method, as follows:—

The whites of twenty fresh eggs are taken, clear of yelk. Iodide of potassium one hundred grains, and five grains of iodine, are dissolved in a little water and added to the albumen, and the whole is beaten up to a froth, and set in a cool place to subside. As in this process it is of the greatest importance that no dust shall settle on the plates, it is necessary that the operating-room should be cleaned the day before by wiping off the floor, walls, and woodwork, with a wet cloth. Shortly before commencing, the floor is to be sprinkled with water.

A stout iron plate is fixed in a horizontal position over a gas-burner, or any other efficient lamp. The albumen having been poured off perfectly clear, is then extended over the plate (absolutely clean), an operation which is aided by first breathing gently on it so as to let the moisture condense. Four silk cords have each a little hook at the end, the other ends are tied together and held in the hand; the hooks are slipped under the plate, which is then supported by the cords. In this way it is suspended over the hot plate and a rotating motion is given to the threads, which keeps the albumen distributed over the plate; presently it is dry.

Fig. 140.

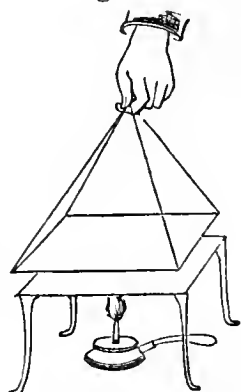

These plates are stored away, and when wanted for use are sensitized in an acid silver bath prepared as follows:—

Nitrate of silver	1 ounce.
Acetic acid (glacial)	2 ounces.
Iodide of potassium	2 grains.
Distilled water	14 ounces.

From a quarter of a minute to a minute is needed for sensitizing, after which the plate is rinsed under a tap, and laid in fresh water; then dried in any suitable way (p. 353).

The exposure is made in a suitable frame under a negative, for a few seconds, to diffuse light. The development is effected by plunging into a bath of gallic acid, one grain to the ounce. Silver is gradually added until the plate acquires the desired density. Ferrier is said to have toned his transparencies by first plunging them in a weak sublimate solution, and then, after washing, into a one-grain solution of chloride of gold.

§ 2.—Sun-Printing on Glass by the Collodio-Chloride Process.

Instead of developing a weak image on glass, we may carry it to its full strength by direct printing. There are two methods usually employed for this purpose, the collodio-chloride process of Mr. Simpson, and the albumen process; the first is the easier and most generally employed, the second (to be described in next section) is more difficult, but gives richer effects.

When a collodion containing chlorides only, instead of iodides and bromides, has nitrate of silver added directly to it, the chloride of silver which is formed, in place of falling at once to the bottom, remains for a long time suspended in the collodion, giving it a milky appearance. The nitrate of silver is kept a little in excess, and when this liquid is coated upon glass or paper, a surface is obtained which may be printed upon very much in the same way as albumenized paper. (Respecting collodio-chloride on paper, see § 4.)

Mr. G. W. Simpson, who first proposed this method, directed to make an ordinary plain collodion with equal parts alcohol and ether and six grains of pyroxyline to the ounce, and salt it with

Chloride of strontium	2 grains.
Citric acid	1 grain.

to each ounce, and to sensitize by adding nitrate of silver in the proportion of $7\frac{1}{2}$ grains to each ounce, in fine powder, shaking up well.

Chloride of strontium has the advantage of easy solubility in mixed alcohol and ether (the chlorides as a rule are less soluble in this mixture than the iodides and bromides), but experience has shown that it does not give as good a tone as some other chlorides.

The writer finds as the result of his experiments with this process, that it is better to use considerably more pyroxyline in the collodion than six grains, especially when the surfaces are not very large. With glass plates of quarter and half size *fully nine grains* to the ounce may be used, and the effects are much richer than with less quantities. He has also found that the addition of *carbolic acid* greatly improves the richness and depth of effect, but unfortunately this treatment can only be used with collodio-chloride on paper; it does not answer on glass, as the carbolic acid separates out in drying on glass.

The writer also finds it a material improvement to dissolve the nitrate of silver in a part of the alcohol. When put in in powder, part does not dissolve. Some have tried dissolving the nitrate in water, but this renders the collodion much less manageable and more apt to give irregular films and mottled and spotty effects.

Dr. Liesegang has lately published the following formula:—

Alcohol and ether, equal parts	1 ounce.
Pyroxyline	9 grains.
Chloride of lithium	1 grain.
Citric or tartaric acid	2 grains.
Nitrate of silver	8 “

Where chloride of lithium is not to be had, chloride of cadmium may be substituted, using twice the quantity. For pyroxyline, Dr. Liesegang recommends one-half of his pyroxyline and one-half ordinary soluble cotton. He shakes up the nitrate of silver in crystals, and at the end of a day removes the undissolved part, powders it in a mortar, and returns it.

The author recommends to dissolve whichever chloride is used in half the alcohol, adding to it the ether, and dissolving in the mixture the pyroxyline. The powdered nitrate of silver is to be put into a large test-tube or small flask, and the alcohol added in separate portions and boiled. In this way the nitrate is speedily got into solution, and this solution is poured into the collodion and shaken up. Operating in this new way, all the difficulties encountered of having the chloride of silver to fall in clots are done away with, and a clear, smooth emulsion is obtained, which keeps in excellent order for weeks.

The author has obtained good results with fused chloride of calcium in the collodion, instead of chloride of lithium or cadmium. Of the calcium salt, one and a half grain to the ounce

of collodion will be proper, and eight grains of nitrate of silver. With chloride of calcium, tartaric acid must not be used, or a gradual precipitation takes place which ruins the collodion.

To keep the film from slipping from the glass, edge it with India-rubber dissolved in benzine, as described for dry plates (see p. 352), or with albumen, but in neither case should the application extend beyond the edges, a full substratum is injurious. Print till the shadows are bronzed, but not too deeply, remembering, however, that an under-printed plate is wholly worthless, whilst an over-printed one can be reduced by using a stronger fixing solution and leaving longer in it. Tone in any gold toning bath, using it very weak.

To fix, leave for five minutes in a weak fixing bath, one and a half ounce of hyposulphite to the pint of water.

M. de Constant first proposed *fuming* the plates, and certainly they print more quickly and deeply when so treated. The question whether fuming is necessary will depend very much on the character of the cotton. When a deep tone cannot easily be got, fuming will be found to help. Remove the stopper of an ammonia bottle and pass the plate a few times over the mouth.

Special frames are made for printing on glass which permit of examining the print. The sensitized glass plate is held between two iron straps which are secured by screws. The vignetting boards furnished with the frames rarely fit as closely as they should do. Any motion is of course fatal to the sharpness of the print, therefore the boards should be well wedged up.

Miniature Effects on Ivory are best got by transferring collodion films to the ivory, the surface of which is to be prepared beforehand by polishing it with a little fine cuttle or pumice powder, and then immersing for a minute in a warm solution of gelatine (about 20 grains to the ounce). The image is printed on glass first coated with gelatine, and then with collodio-chloride (or on enamel or collodio-chloride transfer paper). After toning and fixing in the usual way, wash in a few changes of cold water, then immerse in warm, when the film will float off. (Acidulating the water with a drop or two of sulphuric acid to the ounce will facilitate separation.) Remove the film to a vessel of cold water, and float on to the prepared ivory surface. (B. J. Edwards.)

§ 3.—Albumen Positives on Glass.

Clear white of egg by beating it to a froth, adding first to twelve ounces of albumen a quarter of an ounce of clean, pure sal-ammoniac dissolved in an ounce and a half of water. Coat the plates, dry, and sensitize.

The silver bath is made by dissolving two ounces of nitrate of silver in sixteen of water, acidulating with acetic acid.

When albumen positives on opal glass are thoroughly well made, they exhibit greater force and more transparency of shadow than collodio-chloride work. They are, however, extremely slow in printing, and the success of different operators has been very various.

Positives on glass appear to require longer and more thorough washing than negative glass work, to preserve them from fading.

§ 4.—Collodio-Chloride Printing on Paper.

The sensitive collodio-chloride mixture (p. 389) may be coated on paper instead of glass, and be printed and toned in the same way. But as the film is very apt to detach itself from the paper, this last must be prepared with a coating of gelatine. The writer has never met with any paper of which the sizing was qualified to take the place of this coating, which may be prepared as follows:—

Nelson or Coxe's sparkling gelatine	. . .	400 grains.
Syrupy glycerine	$\frac{1}{2}$ fluidounce.
Water	16 fluidounces.

The gelatine used alone renders the paper excessively stiff; this led the writer to experiment with glycerine added, the effect of which is to greatly reduce the stiffness. Even with this addition, however, the paper curls up somewhat, and therefore, after it is quite dry, it should be laid in press for some time, and comes out exceedingly flat.

The annexed cut represents a piece of the coated paper laid on a convenient piece of thin flat board, provided with a handle at one corner. The two farther corners of the paper to be collodionized are secured with pins, the thumb keeps down one other corner, whilst the fourth is left open, from which to pour off the excess.

Fig. 141.

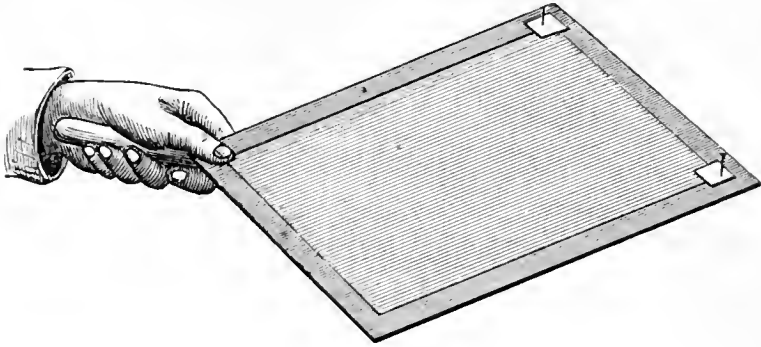

It is, however, very convenient to lay the paper on such a board, and, instead of pinning it, to fold up the edges about an eighth of an inch high, in order to keep the collodion from working over, and especially from getting upon the back of the paper, which result quickly follows if the collodion is carried all round the sides without turning them up.

The writer has found that a considerable increase of richness and tone is got by the addition of *phenic (carbolic) acid*. To a measured quantity of the sensitized collodion add about ten per cent. of this acid, and it will be found that a much richer tint is produced than when the carbolic acid is omitted. This method works well upon paper, but not upon glass. The printing is done in the ordinary way, and the succeeding operations are the same as when glass is the support. (See sec. 2.)

§ 5.—Photographic Enamelling.

Of all forms of picture-making, the enamel may be considered the most permanent. Even the carbon process is liable to the objection that the paper on which the print is made is a very perishable substance, and positives on glass by the collodion process are liable at best to many injurious influences from which an enamel, burnt in upon glass or porcelain, is evidently free.

For reproducing photographs in enamel, several ingenious processes have been proposed. Two at least have been worked commercially upon a large scale: that of Lafon de Camarsac, in Paris, and that of Grüne, in Berlin. Lafon has maintained his a close secret, whilst Grüne, with commendable liberality, has given his to the public. It is his that will be here first given.

There exists no difficulty whatever in transferring a collodion film to any other support. For this purpose it is best to diminish

the adhesion of the collodion, by rubbing the glass beforehand with a little wax dissolved in ether; or, as proposed by Mr. Woodbury, add to the collodion two or three drops to the ounce of a saturated solution of beeswax in ether, which renders the film easily transferred without affecting the photographic properties of the collodion.

The operator prepares a glass collodion positive, which must, of course, be a positive by transparency, and not an ambrotype. This may be done in several ways (for which see the previous sections of this chapter).

The next step will be to tone with weak solution of bichloride of platinum instead of chloride of gold; wash and dry. Run a penknife round the edges, plunge the negative in water, and float off the film. It will be advisable to add a little acetic acid to the water; acids tend to loosen films from their supports, alkalis to increase the attachment. Receive the film on the porcelain surface, and, after allowing it to dry, dissolve out the collodion film with mixed alcohol and ether. The image in platinum will remain upon the porcelain. It then only remains to apply a suitable flux, and burn in the picture in a muffle. Grüne has not given the composition of the flux that he uses, but it is probable that Leth's flux will be found satisfactory. It is made as follows:—

Red lead	6 ounces.
Fine quartz sand, or pounded quartz	2 “
Borax	1 ounce.

Melt in a crucible, and, after cooling, reduce the glass formed to a fine powder. Strew this over the plate, place in a muffle, and raise the heat just high enough to fuse the coat of flux into a transparent glass over the picture.

This process can also be used for producing designs in gold upon glass or porcelain. To effect this, the positive is toned with gold, thoroughly, and the rest of the treatment remains the same, except that a reducing flux must be used. No half-tone can be obtained in this way, because the gold, no matter how thin, exhibits its full metallic color. It easily acquires a brilliant surface by polishing. Beautiful designs in gold of the most complicated figures, have been burnt into porcelain by Grüne by this process.

Those desiring further details may consult the *Photographisches*

Archiv, Band VI., 346; *Photog. News*, IX., 457; or Martin's *Handbuch der Email-photographie*, Weimar, 1867.

§ 6.—Photolithography.

To be able to transfer a photograph to stone or metal, and to print a large number of copies therefrom, is evidently a most valuable application of the science; and this is now accomplished in a very admirable manner.

It is evident that the production of half-tone is more difficult than the simple obtaining of black and white, and that different means must be employed. The processes therefore will be classified under these two different heads:—

A.—PROCESS GIVING ONLY WHITE AND BLACK.

Liesegang's Process.—Liesegang floats ordinary albumenized paper (the salting is not objectionable) upon a solution of chromate of ammonium. Then exposes under a strong, clear negative, till a strong image is got. Next lays it against a zinc plate, and passes through a press. Next lays it, face up, on cold water, till the image becomes visible. Takes a clean sponge, previously cleaned well with chlorhydric acid to get rid of grit, and removes the excess of ink. Then transfers in the usual way of lithographic transfers.

Liesegang attaches importance to the nature of the ink used for inking in the zinc as above mentioned. He takes—

Venice turpentine	8 $\frac{1}{4}$ ounces.
Wax	1 ounce.
Palm oil	1 “

These are to be heated in an iron pot until they take fire. Then stir in—

Lithographic transfer varnish	33 ounces.
Linseed oil varnish, No. 2	16 $\frac{1}{2}$ “

B.—PROCESS GIVING HALF-TONES.

Albertype.—The older processes are likely to be quite superseded by the albertype, of which the following is the specification for the French patent. Coat in the dark room a heavy glass plate with—

Filtered water	300 parts.
Albumen	150 “
Gelatine	15 “
Bichromate of potash	8 “

Dry *in the dark*, and then expose to light *through the glass*, carefully protecting the other face in order that the hardening may proceed from the bottom (next the glass) to the surface, and be perfectly solid. Half an hour to two hours' exposure. Coat again with—

Gelatine	30 parts.
Bichromate	10 “
Water	180 “

Expose under a negative, wash for about fifteen minutes, and dry. Then slightly wet it and work it on a lithographic press in the ordinary way with ordinary printing ink.

§ 7.—Photogalvanography.

It has been known for a period of years that when a mixture of gelatine and bichromate was extended on glass and exposed under a negative, all those parts protected from the light could be made to swell up by soaking the film in water. Consequently the image is produced in relief.

The writer of this manual worked out the details of a process himself, and was the first to publish any practicable method, which will be found in full detail in the *British Journal of Photography* for February 10th, 1865. Briefly, the process consists in coating glass with a film of—

Gelatine	200 grains.
Water	4 ounces.
Cold saturated solution bichromate of potash	5 drachms.

When dry, expose under an average negative to direct sunlight for two to three minutes. Then leave in water for about two hours, changing frequently, then let dry.

The surface may receive a conductor in several ways. Brush over with an ethereal solution of chloride of gold, let dry, place in sunshine, and apply a solution of protosulphate of iron. This is the writer's method of gilding the film, which takes a brilliant gold surface, and is then ready to be plunged into the electrotype bath.

But, on the whole, the writer preferred to treat the dry gelatine

film (after the bichromate, of course, had been thoroughly removed) with alcoholic solution of nitrate of silver, and then to fog it with pyrogallic acid.

By means of the electrotype bath, a copper reproduction of the relief is obtained from which to print.

Woodbury's Relievo Process.—The above method is evidently applicable only to the reproduction of engravings and wood-cuts; negatives of natural objects, made up of half-tones, cannot be used for it. Woodbury ingeniously avoids this difficulty by a very valuable process, which has been patented.

It is easy enough, by the process just above described, to obtain a reproduction in copper of a gelatine relief of objects containing half-tones. This reproduction will not, of course, have lines like a copperplate, but will consist of undulating depressions and elevations. The difficulty lay in making this to print. Mr. Woodbury's idea was to mix a little black pigment with gelatine, to spread this over the plate, and then with a flat surface to remove the excess. A piece of paper being then pressed against the plate, receives the remaining gelatine. In the portions but little sunk, there will have been but little pigment, and these will print light, and just in proportion to the depth of the sunk portion will be the blackness of the print.

Work of remarkable beauty has been executed by this process, which is applicable to printing on paper, glass, wood, or any other surface.

§ 8.—Various Processes.

Willis's Aniline Process.—This process has likewise been patented. The work produced by it is of rather a common order; its recommendation is its extreme facility and cheapness.

Paper is impregnated with solution of bichromate of potash, to which a little phosphoric acid has been added. After exposure under a transparent positive, it is exposed to vapors of aniline, which develop a grayish image. The print is then merely fixed by simple washing. As a positive affords a positive, plates, drawings, &c., can be copied without the intervention of a negative or the use of a camera. The process is carried on commercially by the patentee in England.

Prints in Color.—Float close-grained, fine photographic paper, plain or albumenized, on a warm solution of gelatine, six hundred

and fifty grains; water, twelve ounces; bichromate potash, three drachms; glycerine, half fluidounce; letting the gelatine swell first in part of the water. Dissolve the bichromate in the rest. When the gelatine has well swelled, dissolve it by heating, and add (in the dark room) the bichromate solution. Dry the paper in the dark. Expose briefly to direct sunshine *under a positive*. A light picture results on a brown ground. Throw into water for thirty-six hours: the whole disappears, and the back must be marked to distinguish it. Now blot off the exposed surface gently with bibulous paper, leaving it very moist, and rub on powdered color with a wet hift of cotton. The color adheres to the parts protected from the oven, and thus a *positive* results.¹

Very pretty effects are obtained by laying on the paper *ferns, grasses, &c.*, and developing with a green powder, "chrome green" (chrome yellow and Prussian blue, sold ready mixed under this name) answers very well. In this way, positives of a green color are obtained at a single operation. They are perfectly permanent. If the color does not adhere on the image, the exposure has been too long; if it adheres on the image, and elsewhere also, too short. When the color has been applied, hold the print a few moments under a stream of water to clean the whites.

Printing Processes with Salts of Iron.—Most of the salts of the peroxide of iron are reduced by light to the corresponding salts of the protoxide, with a loss of one-third of their oxygen. By applying reagents which act differently on the two oxides of iron, this reduction is made apparent, and a colored picture is produced. Thus, if red prussiate of potash be applied, all the part acted upon by the sun becomes blue; with gallic acid the unexposed part becomes black, and so on.

Chloride of Iron.—Take

Perchloride of iron	50 grains.
Tartaric acid	15 "
Water	1 ounce.

Expose under the object itself or under a transparent positive. Plunge for an instant in distilled water, and then in a saturated solution of gallic acid, a decoction of nutgalls, or a mixture of gallic and pyrogallic acids, according to the time allowed. The

¹ This method of operating, described by the writer in the Philadelphia Photographer for May, 1865, has since been published as new in Berlin, and, with trifling alterations, patented in England.

impression is here in ordinary ink, gallo-tannate of peroxide of iron.

Oxalate of Iron and Ammonia.—Exactly saturate one ounce of oxalic acid with ammonia, add another ounce, and digest the mixture with freshly-precipitated and still moist peroxide of iron. The filtrate, after the liquid is fully saturated with peroxide, gives, by evaporation in the dark, large and splendid green crystals of the double salt.

Paper is sensitized by floating in a minute or two upon a tolerably strong solution of these crystals, seventy to one hundred grains to the ounce, and dried, in which state it will keep for a long time. Exposed under a negative, an almost invisible image is obtained after a brief exposure, which, by ferridcyanide of potassium, becomes a blue picture. This process is due to Herschel. It has the disadvantage that it does not give clean whites.

The writer imagined a remedy for this, which has been very successful; it consists in adding a little oxalic acid to the solution of ferridcyanide, the whites thus remain brilliantly clear. It is necessary, however, to be careful about putting the fingers into the bath. The free ferriprussic acid liberated by the oxalic acid continually decomposes, with production of prussic acid, in a very dilute form, it is true, but still active enough to render care advisable.

CHAPTER XXI.

CARBON PRINTING.

§ 1.—Introductory Remarks.

CARBON printing, in the form now in use, has been the result of the action of many minds, and the honor of its discovery cannot be ascribed to the ingenuity of any one person. It may be traced back as follows:—

The first step was the remark that paper imbued with solution of bichromate of potash, darkened when exposed to light. This was made in 1839 by Mr. Mungo Ponton.

The next was the discovery that gelatine, gum, and some other

bodies, were rendered wholly insoluble when exposed to light in presence of bichromate of potash. This observation was first made by M. Becquerel; subsequently Mr. Fox Talbot patented a method of photo-engraving based on it.

The next idea evolved was, that the gelatine, made insoluble by light, might be made to imprison particles of coloring matter. Thus, where light acted, these would remain; where it did not act, they would wash out by reason of the solubility of the portion of the film in which they were contained. This was an important step, and was made by M. Poitevin in 1855.

This was, in fact, a carbon process; but in this, and in all the efforts made for some time subsequently, the half-tone was extremely defective.

M. Laborde seems to have been the first to perceive that the action of the sun was at first superficial, and only by degrees penetrating through the layer of gelatine. Thus those portions under the transparent parts of the negative became deep black, because the sun rendered the layer of gelatine insoluble through and through, and so attached it fully to the paper. But in the half-tones this penetration did not take place; the action was comparatively superficial; the lower part of the film remained soluble, so that the impressed portion above it was undermined in developing, and broken away. The only indications of half-tone obtained seem to have been due to inequalities in the paper. M. Laborde, though he perceived the evil, did not find a remedy for it except to suggest exposing from the back.

The honor of devising the method of transferring is due to Mr. Swan. He showed that the true plan of developing lay in attaching the exposed surface to paper or other support, removing the original paper support, and so *developing on the under side*. Thus all the half-tone was excellently preserved, and the picture was re-transferred to another and final sheet of paper.

Details.—Since the first edition of this manual was published, the carbon process has been somewhat simplified, and is passing more and more into use in England, where it is better understood than anywhere else.

“Tissue” for carbon printing is sold ready prepared, and is to be sensitized by plunging into a solution of bichromate of potash, one ounce in thirty of water. If more sensitive paper is wanted, the proportion may be increased. As tissue so prepared is liable

to spontaneously harden, and at best keeps but for a day or two, the writer pointed out some years ago the advantage of adding liquid ammonia to the bichromate solution, whereby the sensitive properties are preserved for several weeks. Lately this method seems to have come into commercial use.

After the sensitized tissue has been dried, which operation must be performed rapidly, but not at too high a heat, lest the gelatine melt and run, it is exposed under a negative; the exposed surface is next moistened and pressed against another sheet of paper. With some sorts of highly sized papers, the exposed and moistened surface of the gelatine will adhere without difficulty. Other paper will require a coating of gelatine, or albumenized paper may be employed of which the albumen has been coagulated. The adhesion is made complete by pressure with a wet sponge, or a roller or "squeegee," and then the two papers, with the layer of gelatine between, are thrown into water scarcely lukewarm; presently the original support can be removed, and the print, by lying in the water for a short time, becomes developed. It is finally cleaned off by gentle agitation in cold water.

Under and Over-exposure.—It is of course very desirable that the right exposure should be hit, but a certain latitude of error can be compensated for in the development. If the print clear itself with difficulty, hotter water may be cautiously applied, not, however, until its necessity has become apparent.

On the contrary, under-exposure will show itself by a tendency to clear rapidly as soon as the temperature of the water has been a little raised and when it is barely tepid. This will indicate the necessity of keeping down the temperature and finishing the print in water as cool as will clean the lights.

The print thus obtained is of course reversed. In some cases this is a matter of indifference, but more frequently it is necessary that the print should correspond with the object itself, as does an ordinary silver print. This correspondence is obtained in either of two ways:—

By taking Reversed Negatives.—A reversed negative bears the same relation to an ordinary one as an image in the looking-glass does to the object itself. Accordingly, one method of reversing negatives is to have a small mirror placed just in front of the lens, making an angle of forty-five degrees, so that the reflection in the mirror, not the object itself, is taken on the film. The

mirror must have only one reflecting surface; must be silvered on the face instead of the back.

Another method is to put the film side of the negative away from the lens. Two precautions are here necessary: the glass must be plate, and perfectly free from scratches and faults; the ordinary brass spring at the back of the plate must be removed, and long springs of silver be placed at the ends, so that tips of the springs will rest upon the corners of the plate.

In practice, the first system has been the most successful.

By Double Transfer.—With non-reversed (ordinary) negatives, if the final print is required to be non-reversed, a re-transfer must be made on paper prepared with gelatine.

Evidently it will be prudent to keep down the temperature in the early stages of the operation, and to raise it only as far as becomes manifestly necessary.

Re-transferring.—This is done with gelatine solution.

Water	40 ounces.
Glycerine	1 ounce.
Gelatine	4 ounces.

Heat this long enough to expel all air-bubbles, but do not keep unnecessarily long in fusion, as by such treatment gelatine loses to some extent its power of setting.

Cover the surface of the print very carefully and evenly with solution, either by floating or brushing, then hang up to dry. Dampen carefully the mount, whether this be paper or cardboard, avoiding to dampen too much, lay the print on face down, and pass at once through the rolling press.

The print is now left for a day to dry thoroughly before undertaking the last operation, that of removing the paper which has acted as a support during development. This is done by vigorously rubbing with tufts of cotton dipped in benzine. Then raise a corner, selecting one of the deep shadows where the film is thick, with a blunt knife, bend it well back and peel it gently off. In mounting on paper, Mr. Swan is in the habit of subsequently laying the print for an hour in a five per cent. solution of alum, a step which the writer believes he was the first to suggest.

§ 3.—Other Methods.

Carbon Direct Printing.—In the case of objects devoid of half-tone, and consisting altogether of white and black, the transferring is unnecessary. If gelatine or gum be mixed up with solution of bichromate of potash, and a pigment be incorporated with it, this mixture may be spread evenly on sized paper, and, if exposed under a negative, a positive copy is obtained.

The writer has shown elsewhere that gum is preferable to gelatine for this purpose, inasmuch as it may be spread evenly over the paper with a brush; gelatine mixtures cannot, as they congeal in the operation. He also showed that the perfectly pure whites could be obtained by adding albumen to the mixture, and not without it.

Printing through the Paper, etc.—Laborde first suggested this idea, but, in spite of many efforts, it has never been practically successful, the grain of the paper interfering, unless, indeed, Mr. Pouncy's prints have been, as stated, so obtained.

Pouncy's Process.—Excellent prints have been obtained by Mr. Pouncy, an early and unwearied laborer in the field of carbon printing. In this process the sensitive pigment is composed of asphaltum, printer's ink, and a fatty matter, with or without bichromate of potash. The matters are incorporated with the aid of heat, and strained. All the information given by Mr. Pouncy is that there must be more ink than asphaltum, that it should be as thick as cream, and give an opaque coating when applied to glass. Only some sorts of asphaltum give good results.

The sensitive pigment is to be applied to paper with a broad camel's-hair brush, leaving the brush in the pigment when not in use. The paper dries in a few minutes, and keeps for months.

The paper to be used should be a very transparent tracing paper, or bank-post rendered transparent with poppy oil. Expose with the paper side next to the negative, and develop by immersion in turpentine.

These prints are advantageously transferred to white paper. After the print has become thoroughly hard by exposure to light and air, after development, varnish the surface with a broad camel's-hair brush, and lay the picture face down on the surface to which it is to be transferred, and press in a copying press; when dry, moisten the transparent paper, and it will come off, leaving the print behind.

The exposures in this process are long; from three to five times those of chloride paper. The prints are very beautiful, and probably have the highest claim to permanence of any photographic work on paper, without exception.

Carbon Printing on Glass.—The writer has devised an extremely simple mode of operating. “Tissue,” as sold, is placed in a solution of bichromate of potash, one ounce to twelve of water, a clean piece of *plate* glass is slipped under it, the tissue pressed close, and thus contact is secured without bubbles. After drying, the glass face is cleaned, the negative placed against it (the glass side), and the printing is done by reflected sunlight, or by placing in the bottom of a box three or four feet long, so as to exclude diffused light. Develop in tepid water. No transferring is needed. This method, when well managed, gives a clean, sharp image, and involves but very little trouble.



PART IV.

THEORETICAL CONSIDERATIONS.

CHAPTER I.

GENERAL OBSERVATIONS.

WHEN we attempt to study the functions of light, we find ourselves face to face with questions which continually extend and expand as we consider them, until we are lost in the immensity of the subject.

For all life, such as we know it on this planet, has been ordained by its Creator to exist only under the influence of light. By that agency, carbon is separated from the carbonic acid of the atmosphere, and is combined into all those organic forms of nutriment upon which we rely to support life, either directly as food, or indirectly to nourish those animals which are eventually to constitute our food. Thus, everything that lives upon the face of our planet owes its existence to light.

Light is so powerful in its influence upon organic bodies that there exists scarcely one which is not directly affected by it. If an organic body be formed by the affinities of its component parts acting in the absence of light, then when that body so formed is submitted to the action of light, the affinities of its elements are in a vast number of cases so altered that decomposition results, at least if moisture be present. As familiar examples may be mentioned that almost all colors are bleached by exposure to sunlight, almost all organic substances are essentially altered in their nature by long action of sunlight. Perhaps no more striking instances can be adduced than those of the whole vegetable world. Plants of every description undergo incessant changes under the action of light; these changes take one course so long as the plant lives; with its death a new order of changes sets in.

During its life it not only forms cellular and woody tissues and chlorophyl, &c., characteristic of vegetable life generally, but also vast numbers of complex organic bodies, such as the vegetable alkaloids, the gums, the resins, the sugars, the vegetable oils, the essential oils, &c. &c. After the death of the plant, an inverse action is set up, and these substances tend to resolve themselves, under the influence of light, heat, and moisture, more or less completely into carbonic acid and water.

Inorganic bodies as a class are less sensitive to light, but there are, nevertheless, very many even of these in which a change of affinities is brought about by its agency.

Most commonly the action of light is a *reducing* one, that is, there is a tendency to part with oxygen (similarly with other chlorous bodies, as iodine, bromine, and chlorine). This is analogical with the action of light in producing vegetation by which the carbonic acid of the atmosphere is made to part with oxygen, and enter into new forms of combination. So that the regular and normal action of light may be said to be the reducing one.

Occasionally, however, the action is contrary, and a combination with the oxygen of the atmosphere is promoted. *Phosphorus* is an example of this exceptional action, its union with oxygen is accelerated by light. Another prominent exception may be cited in the action of light upon a mixture of hydrogen and chlorine, bodies which, when mixed together, show no tendency to unite in the dark, but do so with explosion when light is allowed to fall upon the glass vessel in which these gases are mixed in proper proportions.

An examination into the action of light in those processes which the photographer employs, shows that so far as it is chemical, it is invariably reducing. Thus, when a bichromate is exposed to light in the presence of organic matter, the agency of the light enables the organic matter to oxidize itself at the expense of a part of the oxygen of the chromic acid. When a per-salt of iron is exposed to light, it tends to lose one-third of its oxygen, and to pass to the condition of a proto-salt. The same thing takes place in the salts of uranium, which principle forms the basis of the so-called *Wothlytype process*. Some other metals are acted upon similarly: the salts of mercury tend to lose half their oxygen, chloride of gold may lose the whole of its chlorine, and the gold may be revived in metallic form.

CHAPTER II.

ACTION OF LIGHT ON COMPOUNDS OF SILVER.

§ 1.—**Chloride of Silver.**

LIGHT exerts a distinct chemical action upon chloride of silver, of a reducing nature, that is, the chloride passes into sub-chloride with elimination of free chlorine, or of hypochlorous acid. If pure precipitated chloride of silver, well washed and freed from all organic matter, be exposed to light in a sealed glass tube, it gradually assumes a violet color, and loses chlorine. In the dark it regains its whiteness by recovering the chlorine lost. If free nitrate of silver be present, that is, if the chloride of silver be moistened by solution of nitrate of silver, the coloration proceeds much more rapidly.

If organic matter be present, the decomposition is more rapid still, and in many cases the sub-chloride of silver appears to unite with the organic matter, giving rise to the production of compounds much more deeply colored than the simple sub-chloride. Of these is the dark chocolate-colored substance, passing almost to black, which constitutes the body of an albumenized paper print before toning.

§ 2.—**Iodide of Silver.**

The study of the action of light upon iodide of silver presents very great difficulties, and has given rise to considerable difference of opinion.

In studying this subject, it becomes necessary, as the writer of this manual has more particularly pointed out elsewhere, to consider the question in two different forms, and distinguish between the action of light upon iodide of silver in the presence, and also in the absence of organic or other bodies capable of exerting special influences on it.

To be able fully to eliminate the effect of these latter, the writer devised the method of precipitating metallic silver upon

films of glass, and then iodizing these films with iodine dissolved in solution of iodide of potassium. It had been held, indeed, that iodide of silver formed in presence of excess of iodide of potassium was insensitive to light; this view, however, the writer disproved by decisive experiments, and it is now abandoned.

As the film of iodide of silver upon glass was very liable to slip about, an expedient was found to fix it, but substituting ground glass, and this method of experimenting is now the only one known that is capable of affording reliable results.

By these experiments, which cannot be detailed here, the writer was enabled to show—

1. That pure iodide of silver isolated undergoes no chemical decomposition even by very prolonged action of light. Thus a film exposed for many hours to brilliant sunshine was placed aside for a day or two in the dark. It was exposed for a second or two under a negative, and the image of that negative was then developed upon it without difficulty.

2. But if an organic substance be present, then chemical decomposition does take place. Thus, if a film of iodide of silver upon ground glass be washed over with a solution of tannin, and then be exposed for a sufficient time under a negative, a visible image of the negative is obtained.

Development on Iodide of Silver.—Very erroneous notions of the nature of development on iodide of silver have often been entertained, and the writer himself was at one time under the conviction that iodide of silver might undergo such a physical impression as to predispose it to decomposition when brought into contact with certain substances. Careful and extended experiment has led him to return to his older opinion, that the physical impression of light upon iodide of silver is such as merely to predispose it to receive a falling precipitate. This conception should be fully mastered by the student, and may be explained as follows:—

If we take a saline solution which is just ready to let fall a precipitate, and stir it well in a glass vessel, allowing the end of the glass rod to touch the sides of the vessel in stirring, we shall find that (in many cases) the precipitate will form first and in preference on all those parts of the glass which have been touched by the rod. Thus it may be said that the previously invisible path of the rod over the glass has been *developed* by the precipitate. The surface of the glass was only physically, not chemi-

cally, altered by the passage of the rod over it; and yet it attracted, more powerfully than the rest, the descending precipitate. Just so the part of the iodide film which has been touched by light, exerts a more powerful attraction upon the descending precipitate of metallic silver from the developer than those portions which have not been touched.

It appeared to the writer that although the similarity of these phenomena was sufficiently obvious, yet the two might be brought closer together if he could show that an iodide film could receive a species of latent image by mere pressure, independently of light, capable of being developed by an ordinary developer. Experiment realized this without difficulty. Sensitive collodion films were pressed with various surfaces having raised or sunk devices. Then a developer poured over them brought out these devices with great distinctness, *the silver being attracted always in preference to those parts which had received the pressure.* The writer does not, however, mean to affirm that the action of light is necessarily mechanical, as in the foregoing illustration and experiment.

It is very remarkable that although invisible images may be developed on both chloride and bromide of silver, yet the phenomena are of quite a different nature. Development on pure iodide of silver results simply from a power in the film to attract to itself a descending precipitate, and is independent of any decomposition of the iodide in the film, either under the action of light, as may take place in the case of chloride of silver and bromide of silver, or under that of a developer, as may happen in the case of bromide of silver.

That the development in the case of iodide of silver is perfectly independent of any decomposition of the iodide film, is shown by experiments published by the writer, together with Dr. Shepard, of Providence, in which, after an image had been developed on an iodide film, it was dissolved away with solution of acid pernitrate of mercury, and was then, after washing, *reproduced by a second application of a developer.* This exhibits in a striking light what the writer holds to be the peculiar and characteristic action of iodide of silver, viz., that it is so modified by the action of light as to be capable of forming an image out of the silver in the developer, without itself having undergone decomposition either during exposure or under development. In this way only does it seem possible to explain the fact that a developed image may

be dissolved away, and the power nevertheless be left in the film to reproduce the image by a second development.

It has been already explained that in the presence of certain organic and other bodies, iodide of silver undergoes chemical decomposition, and the same seems to be true when nitrate of silver is present. When, therefore, instead of experimenting upon a film of iodide of silver, isolated on glass, we take a common sensitized plate in which both nitrate of silver and an organic body (collodion) are present, the conditions are essentially changed, and chemical decomposition undoubtedly takes place. Consequently, in the ordinary wet collodion process, there appear to be two invisible images simultaneously present in the film—one a latent physical image due to the action of light upon the iodide, the other a chemical image, invisible simply by reason of its tenuity. Both of these may serve as bases of development.

For want of distinguishing clearly between these conditions, and of remembering that what takes place in the case of iodide of silver isolated from all other bodies is very different from what takes place when free nitrate of silver or certain organic bodies are present—for want of bearing this steadily in mind, much that has been written on the subject of this latent image has little or no real value.

The above are the views which the writer has entertained and endeavored to prove. In the opinion of some photo-chemists, however, the action of light upon iodide of silver is always chemical, and no impression is formed except by actual decomposition. But this opinion seems to be at variance with observed facts, and the reactions of iodide of silver cannot be satisfactorily explained by it.

It will be interesting to note that in the case of iodide of silver the *chemical* latent image always offers a stronger basis of development than the *physical*. Now it has been already explained that, according to the view entertained by the writer, the chemical image is never produced upon isolated iodide of silver, but only when some suitable body is present to give rise to its production, consequently it follows that the presence of that body capable of giving rise to the production of a chemical image, may greatly exalt the sensibility of the iodide. It is for this reason that the presence of the bath solution (containing free nitrate of silver) in wet plates, and certain bodies, such as tannin, gum, gallic acid,

etc., in dry plates, greatly diminishes the exposure needed. These latter substances have been called *preservatives*, though it is evident that they are sensitizers precisely as nitrate of silver is a sensitizer.

As the production of a "chemical image," *i. e.*, one depending upon the actual decomposition of the iodide, must always arise from a separation of iodine to a greater or less extent from the silver present, so it seemed natural to suppose that the greater sensitiveness, or, in other words, greater proneness to decomposition resulting from the presence of so-called preservatives, had its origin in an affinity of the preservative for iodine, which affinity, insufficient in itself to produce decomposition, would nevertheless aid the action of the light. This explanation was first made by Poitevin, and has received general acceptance. Vogel has affirmed that all preservatives have this characteristic, that they show their affinity for iodine by decolorizing the blue solution of iodide of starch.

But few experiments appear to have been made to test this view. The writer, at a time when he was experimenting with many new preservatives, tested many of those which had shown themselves useful, with the iodide of starch, found that they all decolorized it. What tends, however, somewhat to weaken this argument, is that the most powerful sensitizers were not always those that most rapidly decolorized the blue test. Thus tincture of *stramonium* showed itself to be a most powerful sensitizer, but exhibited so little action upon the blue solution, that twenty-four hours were necessary to render the action visible.

§ 3.—Bromide of Silver.

The action of light upon bromide of silver has been less studied than that of iodide, because the difficulties which it presents have been less evident than those in the case of the iodide. For it was easily shown in the case of bromide of silver that a chemical decomposition does take place by continued action of light.¹ Hence it was supposed that no physical action of light took place, inasmuch as none was apparently needed to explain the phenomena observed.

¹ This fact the writer has carefully verified upon films of bromide of silver isolated upon surfaces of ground glass.

But the writer has pointed out elsewhere *that the mere fact of the possibility of development by pyrogallic acid in the absence of any free soluble silver compound*, is in itself an unanswerable argument for the existence of such a physical image.

Upon a dry collodio-bromide plate perfectly washed and having present no trace of the nitrate of silver, the application of pyrogallic acid will develop a visible image. Whence does this come? The image is evidently a sub-bromide of silver, perhaps combined with organic matter, but that the bromide of silver in the film afforded the sub-bromide by decomposition is sufficiently clear.

Now although this image may be developed where there was no image visible upon the plate after its exposure, let us even suppose for argument that there was a faint visible image. If the development were conducted with nitrate of silver present, this faint visible image might certainly act as a foundation upon which the strong image was built up. But nothing of the sort can take place where the alkaline development is conducted in the absence of all silver compounds except those in the plate.

It, therefore, appears clear that a latent physical image may exist on bromide as well as on iodide of silver.

But the difference between these compounds in respect of the action of light upon them is very striking.

On iodide of silver the latent *physical* image is produced where the iodide is isolated.

But on bromide only where a "sensitizer" is present.

On bromide isolated, the action of the light can only produce a chemical image; on iodide isolated, it can produce a physical image only.

The action of the light upon bromide of silver, isolated, must be enormously long to produce an impression capable of being developed; the sensitizer abridges this period vastly more than in the case of iodide.

But on bromide isolated, the long-continued action of light may produce a strong, visible image (in an experiment by the writer this was attained by four hours' exposure to strong sun under a negative), which cannot take place in the case of iodide.

Development on Bromide of Silver.—In the case of iodide of silver, we have seen that development is essentially the attraction to the film of a descending precipitate, the film itself remaining (chemically) unaltered. But in the case of bromide of silver

(acted on by light in the presence of tannin, or other sensitizer) the alkaline development consists essentially in a reduction of the bromide in the film, and the production thereby of a more or less complex, deeply-colored substance, forming the image.

The remarkable distinctions between these two developments, as respects their essential characters, correspond to equally great differences in the practical operations based upon them. So that in the wet processes, in which iodide of silver is the altogether essential body, we see those forms succeed best in which a descending precipitate is applied to the invisible image.

But in the dry bromide processes we find only one thing essential: that to the exposed plate there shall be presented a substance like pyrogallic acid, which has a natural tendency to provoke reduction. This substance at once starts a decomposition in those parts that have been exposed to light. We may enhance its decomposing action by alkalies, and so exalt that decomposing agency until it is alone sufficient to produce such an image as we want; or, we take the image so produced, and by adding silver and acetic acid, we may *build upon it* a denser image for our purpose. So far as this building up is concerned, we proceed upon the same principles as in the wet process, but this second step does not in the least affect the character of the first, and that first step differs absolutely and essentially from anything that belongs to the wet development.

It is then (and this is what, if the writer is not mistaken, has not before been correctly presented) by a careful consideration of the essential characters of these two developments, that we arrive at the essential differences between the invisible image as formed on iodide, and on bromide of silver. Each in its absolute essence and freed from such accidental phenomena as may accompany it (and may lead to the production of a chemical image), is physical and not chemical in its nature. But in the iodide the physical impression is one tending to cause the attraction of a descending precipitate, in the bromide it is one predisposing to decomposition when a reducing agent of a proper character is presented.



CHAPTER III.

ACTION OF VARIOUS PORTIONS OF THE SPECTRUM.

WHEN, instead of exposing sensitive bodies to ordinary light, we let fall upon them a solar spectrum, we find that its different portions exercise widely different influences.

We find, also, that the *nature of the prism* used singularly affects the influences exerted by the different portions into which it separates white light. Thus, for example, with a flint glass prism, the most powerful actinic force is exerted by the invisible rays just beyond the violet. But if a prism filled with sulphide of carbon be used, a spectrum is formed, devoid, or nearly so, of invisible ultra violet rays, capable of acting upon sensitive paper. A series of very interesting experiments, chiefly made by Herschel, on the action of different portions of the spectrum, have been tabulated, and will be found in Hunt's valuable *Researches on Light*.

As respects the silver haloids, the action of light commences far beyond the visible rays, and extends some distance into the visible spectrum. Bromide of silver is very faintly affected by green rays, which do not act upon iodide. It has, therefore, a slightly wider range of sensitiveness than iodide.

Below the green come those brighter rays which form the principal illuminating part of white light. These are without effect upon sensitive films of the silver haloids that have never been exposed to light. But Ed. Becquerel has shown that these less refrangible rays have a "continuing" power, that is, that although incapable of themselves to *commence* an impression upon a sensitive surface, even by a very prolonged action, yet if that action be set up by the more refrangible rays, these less refrangible ones can continue and increase it. Thus, if paper prepared with iodide of silver be exposed to the spectrum, the impression ends with the blue rays. But if it be but exposed for a second or two to light, and then to the spectrum, and if a developer be applied, an impression is found to have been made extending to the very end of the visible spectrum.

What is also remarkable in this very interesting investigation is, that the bodies which act as a support to the silver compound may exercise an important influence on the effects produced. Thus the iodide and chloride of silver in collodion or paper, or on a metallic film, are subject to this "continuing" power. Bromide of silver, when formed on a daguerreotype plate, is *not*; formed on collodion or on paper, it is. The image of the spectrum, when formed on bromide of silver *on a plate*, is much longer than the image upon chloride or iodide also on a plate, whereas bromide in collodion or on paper gives a spectrum no longer than iodide or chloride.¹

These results are as important in their relations to photography as they are interesting in themselves, and their bearing on the negative process is too evident to need that the writer should dwell on it. Only it may be remarked that they explain in part some of Mr. Rutherford's results in photographing spectra on collodion; they seem, however, to indicate that in his experiments the spectrum was not wholly purified from white light, for in these experiments impressions of many of the less refrangible portions of the spectrum were obtained in collodions containing the silver haloids.

Heliochromy.

It has been long known that the various colors of the spectrum had the power of impressing themselves upon certain sensitive surfaces, especially upon *sub-chloride of silver*. So that if a piece of paper be impregnated with chloride of silver and then be exposed to light till it darkens somewhat, it may in this condition be exposed to daylight under colored glasses, and after a certain amount of exposure, will be found to assume the color of the glass under which it was exposed. Becquerel has varied the experiment by using *metallic plates*, on which a coating of chloride of silver was formed. Poitevin discovered that bichromate of potash aided chloride paper in reproducing natural colors.

But neither have the results so far obtained been at all beautiful, nor has it been found possible to render them permanent. At the same time, the experiments above referred to are curious and interesting, and there is no doubt that it is in the power of photography to reproduce all the colors of nature.

¹ Becquerel, *La Lumière*, II. pp. 89-92.

PART V.

CHAPTER I.

PHOTOGRAPHY IN ITS RELATIONS TO HEALTH.

§ 1.—Poisons.

IN adopting a pursuit, whether simply with a view to interest and amusement, or with the design of serious study and investigation, or as a business enterprise, every one should attentively consider its relations to his health. Permanent injury to bodily health is an evil so serious that its full magnitude is appreciated by none who have not learned by their own bitter experience. The writer, therefore, appeals to the good sense of every one who may adopt this manual as his guide through the study of photography, in the first place to neglect none of the general precautions which will be here recommended; and in the second, should he find his health in any way suffer, to ascertain at once to what that injury is ascribable, and to lose no time in taking such special action as the case may need. Speaking from personal experience, and having witnessed evil results in others, the writer earnestly desires to induce the habitual adoption of effective precautions.

It is not that photography is necessarily a hurtful art, but its practice brings its votaries into contact with several very strong poisons, which, if used without great care, and still more, if used with the heedlessness that is only too common, are liable to produce the very worst effects. These substances are principally *ether, collodion, cyanide of potassium, corrosive sublimate, chloride of gold, nitric acid, acetic acid, and ammonia.*

Ether, whether swallowed or inhaled as vapor, has a remarkable effect, which, like that of many other active agents, is twofold, stimulating and sedative. The first tendency is to pro-

duce a species of imperfect intoxication, soon followed by more or less prostration; this sedative effect has led to its being used in medicine under the name of "Hoffmann's Anodyne." The effect of its continued use is to produce languor, depression of spirits, and bodily prostration.

Collodion, from the large quantity of ether which it contains, produces the specific effects characteristic of that substance, but also other effects, the precise source of which is not well understood. When collodion becomes much ripened, and especially when it takes on a deep color, it is found to give off a very irritating vapor, which attacks the face, and especially the eyelids, producing severe inflammation. Cases have been cited in which photographers have been in this way obliged to interrupt their pursuit for times varying from a few days to many months. When the photographer perceives a disposition to irritation and inflammation in the face, he may at once suspect his collodion of being the cause.

Cyanide of potassium is, of course, the most dangerous chemical with which the photographer comes into contact. For clearing both positives and negatives, especially the former, it keeps its hold upon photographers, particularly amongst careless manipulators, through two causes. First, if by mismanagement the negative is a little fogged, cyanide, which has a stronger solvent action than hyposulphite, tends to clear it up. Second, the transfer of small portions of cyanide to other solutions by dirty fingers, has not the absolutely disastrous results that follow such transfers of hyposulphite. These considerations are not in the least creditable to the photographer who is influenced by them.

Cyanide of potassium is a compound of prussic acid with potash. In this compound it retains all the dangerous properties that characterize it in the free state. In fact, a solution of cyanide slowly but continually decomposes, absorbing carbonic acid from the air and giving off prussic acid in the form of gas.

This poison may act in three ways. Leaning over a bath of it, or even remaining in a room containing a solution of it exposed on a considerable surface to the air, a small quantity of prussic acid is continually inhaled.

In manipulating with its solutions, the hands come into contact with it. How far chemical solutions are taken up by a perfectly sound skin has been a matter of considerable discussion among physicians, but recent careful experiments made in Paris leave

no doubt that the skin continually absorbs liquids which remain in contact with it.

If, however, the continuity of the skin be broken by a scratch, cut, pimple, or otherwise, cyanide is readily absorbed at such places, and a considerable amount of local inflammation may be produced. In some cases paralysis of the limbs has been affirmed to have resulted, and even paralysis of the whole side.

For several years past the photographic journals have published numbers of letters from photographers who have had their health injured, or, in many cases, ruined by the action of their chemicals, and especially by cyanide. *Paralysis* is the most common result, attacking most frequently an arm, but sometimes the entire side. One describes his hands as for months continually exuding some anomalous secretion, sticking them fast to his gloves, and interfering with their use. Another complains of intense pains in the fingers, only to be rendered endurable by keeping them for hours in cold water. Others find the whole bodily health broken down, and no help to be obtained from medicine. One photographer (M. Davanne), after having had his hands wet with cyanide solution, moistened them with acetic acid, and was almost instantly struck down insensible with symptoms of violent poisoning. His friends barely saved him by long-continued pouring of cold water on the head.

It should always be remembered that when any substance or compound having an acid reaction comes into contact with cyanide of potassium, the dangerous tendencies of the latter are greatly increased—in fact, prussic acid is at once set free.

A very painful class of casualties are those resulting from *carelessness* with cyanide. Solutions are left about; sometimes the incredible carelessness of leaving them in drinking tumblers is committed. For all lives lost in this way (and there have been many), he who left the solution about is morally responsible. Once for all, the use of this chemical should be abandoned totally by photographers. If any insist on using it, the least such can do is to keep it exclusively in vessels marked conspicuously, POISON.

Corrosive sublimate is another dangerous chemical, but not capable of acting by inspiration through the lungs. Accidents with sublimate arise either from absorption or internal administration.

Absorption through the skin takes place slowly, and the fingers

may be occasionally wetted with sublimate solution without any noticeable bad results; the danger lies in this, that there is no safe line that can be drawn, and that the photographer can form no conception as to the point to which he may go with impunity. Evil must be done before its danger can be recognized.

Administered internally, sublimate is a powerful corrosive poison.

Chloride of gold acts as a poison by causing deep and severe ulcerations upon the fingers of those who are continually working in toning baths. Such manipulation should be managed by means of spatulas and forceps of glass or whalebone.

Nitric acid acts toxically through the lungs. It stains the skin a deep yellow, which lasts until the epidermis is worn off, but no other evil seems to result from contact. It is possible that it is not absorbed, but that it kills the skin too quickly for such an effect. Nitric acid diffused through the atmosphere and inhaled, acts as a direct poison. Some years since, Mr. Stevens, together with an assistant, undertook to sop up a quantity of nitric acid spilt by the breaking of a large vessel, an act which resulted fatally to the one and nearly so to the other.

In less quantities, and inhaled over a longer time, it may produce irritation of the lungs and chest diseases.

Acetic acid acts similarly to nitric, but in a less degree. Its fumes are very irritating to the lungs, especially to weak ones. The quantity of acetic acid used in photographic operations is often very large, so that in many professional establishments there is always a strong smell of this acid. Such a state of affairs must be hurtful to every one connected with the place, and ought to be done away with at any cost.

Pyrogallic acid has been stated lately to be an active poison, having, in its action on the system, certain analogies with phosphorus.

§ 2.—Remedies.

General.—It is evident that all poisons which are liable to be carried upon the atmosphere should, as far as possible, be kept in closed vessels. Cyanide should never be left in open pans or baths. Nitric acid baths used for cleaning (for which purpose bichromate and sulphuric acid is far preferable; see article on cleaning plates) should never be left exposed to the atmosphere,

but the pans or baths should be protected, and be kept under a chimney or a draught of some sort.

Next to avoiding the production of fumes, the best thing is *ventilation*. In the case of ether and collodion, this is the only efficient means, as the fumes of collodion cannot be kept out of the air. For this reason plates should be collodionized, not in the open air of the dark room, but in a sort of closet partitioned off and provided with a vent above and below. The operator is outside of such a closet, and the fumes are not inhaled as the plate is coated. This is a very important precaution.

When acid fumes have got into the air, their removal can often be expedited by pouring out ammonia. This, though efficient, has the disadvantage of causing thick white clouds, which subside by degrees only. Still, its use is occasionally valuable.

Special.—Poisons taken internally must be treated with specific remedies; the object is always to bring the poisonous matter into some inert compound.

Cyanide of potassium has the remarkable property of taking up iron and forming a perfectly innocuous substance known as yellow prussiate of potash, ferrocyanide of potassium. *Proto-sulphate of iron* may, therefore, be taken internally in considerable quantity. Cyanide of potassium, in presence of a mixture of a protosalt and persalt of iron, is converted instantly into Prussian blue, a substance not at all injurious to the system. Those who use cyanide habitually, will do well to keep the mixture of proto and persulphate of iron in readiness for accidents to others, if not to themselves. Common sulphate of iron in solution, by continued exposure to air, peroxidizes, and may be used for this purpose.

For *corrosive sublimate* when taken internally, *white of egg* is usually administered. The quantity of the remedy must be considerable—the raw white of one egg to each three or four grains of the poison swallowed.

Poisons in cuts and scratches should be immediately treated with the same remedies as those advised where the poison has been taken into the stomach. For injuries occasioned by the *continuous absorption* of poisons, no satisfactory remedies can be recommended, recourse must be had to the advice of an educated and intelligent physician.

The writer feels that he cannot leave this subject without again advising photographers to pay more attention to the conditions

of health than is generally done. Those who have the direction and management of establishments, should never forget that those whom they employ are often much more exposed to these dangers than themselves, without having the opportunity or the privilege of introducing better arrangements and precautions. And that, however employers may feel disposed to risk their own health, they are not justified in causing others, either ignorantly or knowingly, to share such dangers. Many a man, when he has found his nervous system permanently injured, or his lungs weakened, commences care-taking when it is too late. The needful precautions are neither many nor troublesome; they should be taken from the outset, and steadily persevered in.

CHAPTER II.

CHEMICAL MANIPULATIONS.

SOME of the simpler chemical manipulations are frequently needed in photography, and deserve a brief description here.

§ 1.—Weighing and Measuring.

No operations are commoner or seem easier than these, and yet in none are mistakes more frequent.

WEIGHING.—For the operations of photography, a small balance like that on page 421, having a nine or ten inch beam, will be the most suitable, using a heavier and commoner pair of scales for weights over one or two ounces. Fig. 142 represents the French pattern of "*trebuchet*" or tilting scale, now largely manufactured here. The pans rest on the box until the lever is pressed, when they swing loose.

In weighing, it is necessary always to beware of "sticking." When the pans are nearly equally loaded, but not exactly, the needle may point at the centre by reason of the beam not moving with entire freedom. By making the pans oscillate a little, it will be easy to see if the needle moves on each side to the same distance from the centre.

Fig. 142.

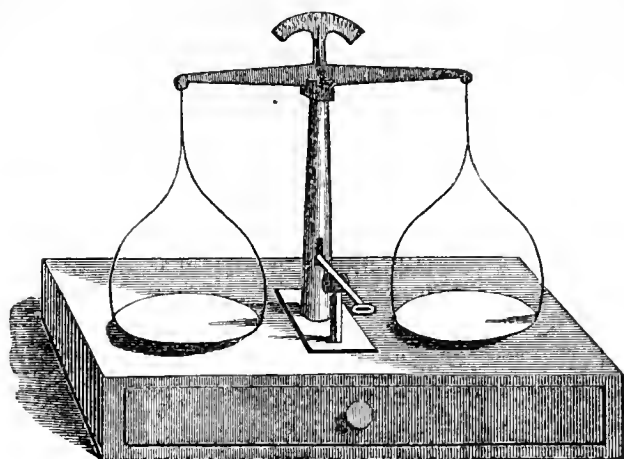

Inattention to reckoning the weights is another common source of mistakes, especially with our defective system.

The following are the details of the weights as now used. The *grain* is the same always.

Avoirdupois.

- 1 drachm = 54.7 grains nearly.
 1 ounce = $437\frac{1}{2}$ grains.
 1 pound = 16 ounces = 7000 grains.

Apothecaries.

- 1 drachm = 60 grains.
 1 ounce = 480 grains.
 1 pound = 12 ounces = 5760 grains.

Troy.

- 1 pennyweight = 24 grains.
 1 ounce = 20 dwt. = 480 grains.
 1 pound = 12 ounces = 5760 grains.

Decimal Weights authorized by Congress.

- A thousand milligrammes make one gramme.
 A thousand grammes " " kilogramme.
 One grain corresponds to 65 milligrammes nearly (64.8).
 One drachm apothecaries' weight to 3.882 grammes.
 " ounce " " 31.1035 "
 " " avoirdupois " 28.349 "
 " pound " " 453.59 "
 " " apoth. or troy " 373.242 "

1 gramme = 15.43234 grains.

1 kilogramme = 2 lbs. 3 oz. 119.85 grs., or 15,432.35 grains.

Fig. 143.

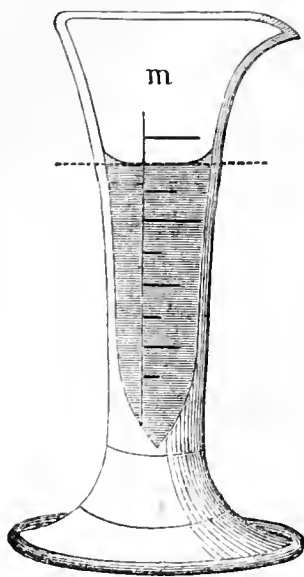

MEASURING is still more liable to error than weighing. The vessel must be kept carefully perpendicular, and be examined by a level light. The surface of the liquid is always curved, being higher at the edges. The lower level is that to be used, that is, the lower part of the curved surface must correspond with the lines ruled on the glass, as shown by the dotted line on the figure, which represents a "minim glass."

Liquid Measure.

1 fluidrachm = 60 minims.

1 fluidounce = 8 fluidrachms.

1 pint = 16 fluidounces.

1 gallon = 8 pints.

§ 2.—Heating.

The *alcohol lamp* was for a long time the favorite source of heat when needed on a small scale; its advantage lies in its high temperature and freedom from smoke. As alcohol both evaporates and absorbs water from the air, the wick should be kept covered. If the wick-tube is passed through a cork, this should always have a groove to permit escape of vapor, or it will be liable to be driven out with a dangerous explosion.

But whenever gas can be had, the *Bunsen burner* (see Fig. 144) conveniently and economically replaces alcohol.

The *sand-bath* is an excellent means of applying a gentle heat to large surfaces.

A very simple and convenient form of sand-bath is to have a circular rim on top of a stove, filled with clean building sand. The heat is thus applied much more evenly than if the vessel were set directly on the stove without the interposition of the sand, and the danger of breakage is greatly diminished.

A sand-bath may also be established over a Bunsen burner. Get a worker in sheet-iron to make a cylinder of stout galvanized iron, about twelve inches in diameter, and ten high. The top and bottom are turned over heavy iron wire, and curved pieces are cut out at top and bottom, to serve as air-passages. A circular piece of sheet-iron is hammered into a basin thirteen inches across, and this, filled with sand, rests on the top of the cylinder. Such a cylinder will support a very heavy weight.

§ 3.—Evaporation.

In evaporating, two important points are to be borne in mind. First, the heat should not be contracted to a single point; and second, it should not be so diffused as to strike that part of the vessel that is above the liquid. In either case fracture is apt to occur; in the latter case, almost certainly.

For large operations the sand-bath will be proper; that is, for evaporating negative baths, and such work. For small operations the following arrangement is capital.

Procure a lampstand, with a strong ring about five inches in diameter; take a piece of strong but fine and close-meshed brass wire gauze, six inches square, lay it on the ring and press the corners down under the ring, so as to fix it firmly to it. This wire gauze forms a support which will carry anything from a capsule an inch in diameter to a basin of twelve or fifteen inches, provided the lampstand be strong and stout as it should be, as well as flasks, beakers, or, in fact, any utensil whatever. The Bunsen's burner stands under this, always ready for service at a moment's notice. The wire gauze stops the flame, and permits only the hot air to pass through, thus giving a great protection against accident, whilst scarcely interfering with the heating.

A *tripod*, if made strong and stout, is also a good support, but far less convenient than the foregoing, inasmuch as it cannot be raised and lowered, and is never so strong as the lampstand. In this case, also, a piece of wire gauze should be interposed between the vessel and the source of heat.

Fig. 144.

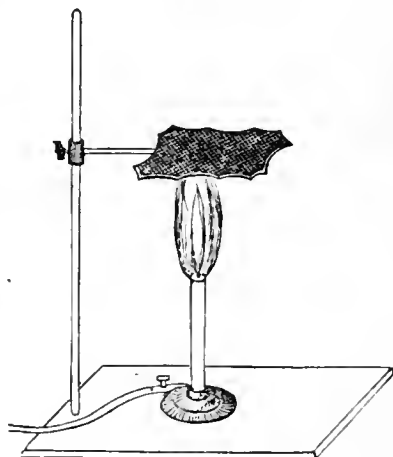
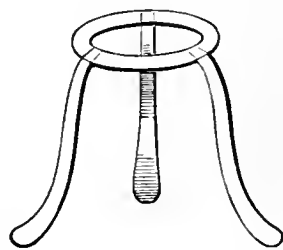

Fig. 145.



§ 4.—Filtration.

Of *filtration*, all that need be said is, make the filter always a little smaller than the funnel, and always wet it before pouring in the liquid to be filtered. Select a good paper, which filters

clean and quickly, and when that which exactly suits is found, a good supply should be laid in. Nothing is more vexatious than to wait for a slow filtration.

§ 5.—Pouring.

In transferring liquids from one vessel to another, there are two contrivances by which the clean performance of the operation without loss may be greatly facilitated. These are *greasing* and *rod-pouring*.

Fig. 146.

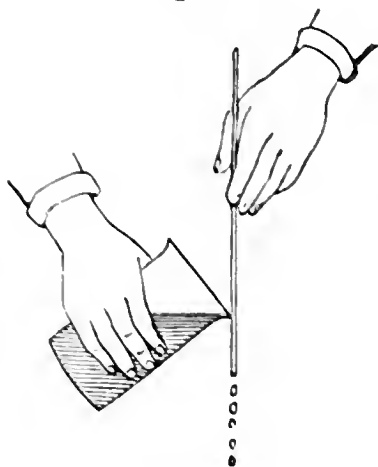

Greasing is the application of a little tallow on the finger under the lip over which the liquid is to be poured. For pouring valuable liquids out of large vessels, especially if nearly full, this mode is very useful.

In *rod-pouring*, the glass rod is first wetted with the liquid, and is then held to the lip of the vessel, which is so inclined as to pour slowly, the stream following the rod (Fig. 146). Both methods may be combined.

§ 6.—Fusing.

For reducing chloride of silver in the dry way, a Hessian crucible may be used. The chloride is intimately mixed with twice its weight of dry carbonate of sodium; this mixture is rammed tightly into the crucible, which is by degrees raised to a white heat. As the Hessian crucibles are porous, some of the silver may sink in. To obviate this, fuse a little borax in it, or use a *Paris clay* crucible, which is not liable to this objection.

For fusing nitrate of silver, a Berlin or Meissen porcelain basin will be required; none other can be depended upon. The Berlin are the best, and are stamped in blue; some with the letters K P M, some with a Prussian eagle inside of a circle. Both of these sorts are excellent. With care, the operation is perfectly safe, and fracture need not be feared. The Bunsen burner will give the necessary heat for small quantities, or combined burners for large.

§ 7.—Neutralization.

Where the object is merely to render an alkaline liquid acid, or an acid one alkaline, it will be sufficient to add the appropriate reagent, until blue litmus-paper, by turning red, indicates acidity; or red, by becoming blue, shows alkalinity, as the case may be.

But an exact neutralization, as where an acid or an alkaline liquid is to be rendered exactly neutral, is an operation requiring some circumspection. If, for example, an acid liquid is to be neutralized with ammonia, and the latter liquid is added a few drops at a time, the operation will be very tedious, and will be almost certain to fail, an excess of ammonia will almost certainly be at last introduced. The operator, therefore, feels his way. He pours off a part, say a third, of the acid liquid, and adds boldly enough ammonia to make it quite alkaline. He then adds enough of the remainder of the original liquid to render the mixture decidedly acid. Repeating this several times, he gets a pretty clear idea of the proportion of ammonia, unknown at first, which is required. Towards the end he diminishes the quantity of each successive addition, till with the last drops, with care, he obtains an exact neutralization.

There are some cases in which the neutralization is effected by the addition of a substance which, even if added in excess, produces a precipitate, and so leaves the solution neutral, so that the addition of an excess of the precipitant is without much importance. An example of this is presented in the neutralization of an acid negative bath with carbonate of sodium. If an excess of carbonate of sodium be added beyond what is necessary to neutralize the free acid, carbonate of silver is formed, and this being but very sparingly soluble in water,¹ is precipitated. The addition, therefore, of a slight excess of carbonate of sodium does not render the liquid more than very faintly alkaline.

In other cases, the neutralization is effected by a substance insoluble in the solution after neutralization. This is the simplest case of all: it is sufficient to add the neutralizing substance in excess, and then to remove that excess by filtration. An example of this is afforded in the preparation of a neutral gold toning-bath. The acid solution of perchloride of gold is agitated with excess of precipitated chalk; as much chalk dissolves as is neces-

¹ Soluble in 31,978 parts of water at 12° C. (Kremers.)

sary to neutralize the excess of hydrochloric acid, and the rest is got rid of by filtration.

Negative baths requiring neutralization must always be treated with bicarbonate of sodium, never with chalk.

§ 8.—Decantation.

Fig. 147.

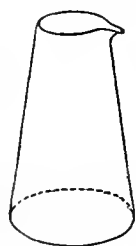

In all cases where a precipitate is to subside, that operation takes place best in vessels larger at the bottom than at the top, tolerably well in vessels with straight sides, and very badly in conical vessels, widening towards the top. Those of this last shape should, therefore, never be employed for decantation. The shape shown in the margin is the proper one.

§ 9.—Cleaning Glass and Porcelain Vessels.

The bichromate mixture already recommended for cleaning glass plates is most excellent for vessels. It should be pretty strong. A most useful plan is to take cold saturated solution of bichromate of potash, and add about one-eighth its bulk of sulphuric acid (or one-fourth its bulk of the dilute acid that comes from the drying-box). If the ordinary acid is used, it must be mixed in a porcelain or thin glass vessel; a bottle will probably break by the sudden heat evolved. For a few moments a corrosive vapor is thrown off; after cooling, however, this trouble disappears.

About a quart of this mixture is to be kept on hand and poured into vessels needing cleaning, which it does very effectually. It may be used again and again until it takes a brownish-violet color, when it should be rejected as spent.

§ 10.—Marking Negatives.

The photographer will often desire to mark his negatives, especially landscapes, with the name of the place, the lens used, or other note of interest. With portraits there are always places convenient for either marking with black varnish, or marking with a sharp point through a dense place, on portions not to be used in the print. But with a landscape negative, good to the very edge, one is not disposed to sacrifice a place for marking.

An excellent plan is to use a *writing diamond*, which is quite different from a glazier's, and may be had of the philosophical instrument makers. With one of these one may write legibly on the back, over a very thin or a very thick portion, without the marks showing in the print, as is the case when a glazier's diamond is used. These writing diamonds are sparks set in steel tubes much like everpoint pencils. They are mostly made in Amsterdam, the great centre of diamond-cutting.

§ 11.—Bending Glass.

An ordinary gas flame is sufficient for bending glass tubes up to half-inch diameter. No particular care is necessary except to apply the heat equally by slowly turning the tube round, and to avoid commencing to bend until the glass is quite soft, otherwise the tube will almost certainly break. The black from the flame will easily wipe off. Lay the bent tube on some non-conducting surface to cool slowly.

§ 12.—Piercing Holes in Corks.

This is best done with borers consisting of tubes of brass or tinned iron. The former are to be had of the instrument makers, in sets of different sizes sliding into each other. The tin tubes can be made by any tinsmith, and should have a cross-piece as a handle across one end. This end-piece has a hole cut into it of the same size as the tube, in order that the pieces of cork punched out may pass freely through. Several sizes will be wanted, say $\frac{3}{16}$, $\frac{4}{16}$, $\frac{6}{16}$, $\frac{1}{2}$, $\frac{3}{4}$, 1 inch. A set of a dozen comprising other intermediate sizes is still more satisfactory. The edges should be occasionally sharpened with a rat-tail file.

Fig. 148.

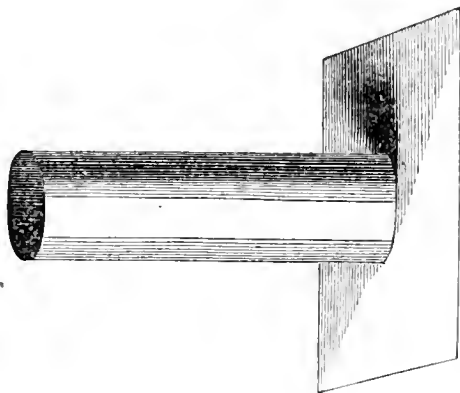

§ 13.—Softening Corks.

All corks are the better for *softening*. The cork-pressers usually sold are next to worthless. To roll the cork under the foot, with a piece of clean paper above and below it, is not a bad way, but the circular cork-pressers, consisting of a notched wheel and excentric band, are most excellent. A cork should be softened before boring, not after.

§ 14.—Blackening Brass and Wood Surfaces.

Brass.—Dissolve a drachm of bichloride of platinum in one ounce or one and a half ounce of water, and add a grain of nitrate of silver. Clean and polish the brass surface, warm it, and apply the solution with a small tuft of cotton. Rub till dry, and then finish off with a little dust of graphite, avoiding to put on any polish, which would convert the surface into a reflecting one, and enable it, though black, to send back white light.

Brass surfaces are cleaned for these purposes, either by rubbing with sand and polishing powder, or by applying nitric acid. The fumes that rise should be carefully avoided, and the acid be only left on till a bright surface is obtained.

Wood.—Take five parts of lampblack, two of finely pulverized gum-arabic, and one of brown sugar; mix to a thick paste with water, and rub on with a piece of flannel. This is excellent for the insides of cameras and drying-boxes; it does not come off on the fingers. A second coat aids in obtaining a perfect blackness. If it soils the finger when rubbed on it, there was too much lampblack; if there show itself any reflection, there was too little.

§ 15.—Paste.

Paste is far preferable to mucilage for attaching labels. If well boiled, and then mixed with a little carbolic acid (one drachm to eight or ten ounces of paste), and placed in a bottle with a cork pierced to carry a brush, it will keep in excellent condition for a year or more. When gum mucilage is used, the addition of a very little glycerine will make it hold better, and diminish its tendency to separate or "scroll."

§ 16.—Filtration of Viscid Liquids—the Percolator.

Solutions of gum, of gelatine, and other viscid liquids, are best filtered through a percolator. This is a porcelain funnel without a neck, and pierced with twelve oval openings. It is so set into a jar that all the openings shall be below the upper rim of the jar. A paper or other filter is placed inside. When paper is used, it is best to make the lower part of the paper double, by putting in a second and smaller filter to prevent bursting at the bottom. The facility of filtering through the percolator greatly exceeds that of an ordinary filtering funnel.

Fig. 149.

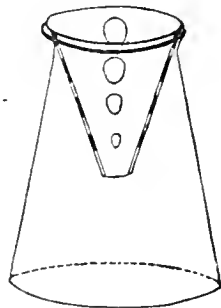

§ 17.—Buckle's Brush.

A string is passed over a tuft of cotton, and the end of the tuft is pulled by the string into a glass tube. This sort of brush has

Fig. 150.

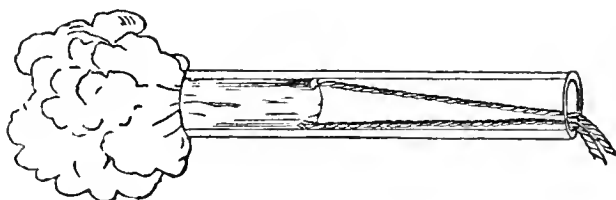

been largely used for extending solution of nitrate of silver, and other solutions, over paper. When soiled, it is easy to change the cotton for a fresh piece.



NOTES AND ADDENDA.

Permanent Silvered Paper (see p. 277).—At the time when the article on the author's new process in the body of this manual went to press, there had been so far time only for testing its keeping qualities about seven weeks. Since then, the paper has been used after keeping it *for over three months*, with entire success, and the great value of the method has been fully confirmed. As already mentioned, when the paper is long kept, it acquires a slight yellowish tinge on the face, and a light brownish coloration on the back; but as these disappear in the operations of toning and fixing, when carried through precisely in the ordinary manner, they have no importance. The prints executed on paper kept over this long period are not to be distinguished from those made immediately after sensitizing.

The object of this process is not, however, so much to keep paper over these long periods, as to enable those who work on a small, or even on a moderate scale, to avoid the trouble of daily, or almost daily, preparation of small quantities of paper; even, however, for those who operate more largely the process has its advantages in the avoidance of waste such as constantly results from miscalculation and from unexpected changes of weather, by which vexatious losses are a common experience. It should be remarked that the experiments here described were made during the moderate weather of spring, and that in hot summer weather the time during which the paper can be kept may not reach so great a length.

The writer desires also again to call attention to the fact, that *all* paper prepared by any process with the intention of long keeping, should be sensitized with much more careful exclusion of light than is necessary for paper intended for immediate use. Similar care is necessary when the box containing it is opened to take out part of the paper, in order that what remains over shall not have been exposed to light. It is best to do this in the dark room.

Water-proof Negative Varnish.—Since the remarks on p. 375, &c., went to press, there has been time to extend the observations on the resistance of these varnishes over a longer period. After the plates had been left for *three months* under water, they were in the following conditions:—

The bleached lac varnish (No. 1), and one of the orange lac varnishes (No. 3), were in good condition, and exhibited no signs of injury except that each had a small pucker or fold at one corner, so slight as to have no real importance.

The other orange lac varnish (No. 2) was in an *entirely perfect condition*.

Sandarac varnish (No. 4) was badly torn, about one-third the film was off the plate.

The resisting powers of all these four varnishes cannot be considered as

otherwise than very remarkable, for even the Sandarac stood for a long time, and though inferior to the other three in its resistance to moisture, excelled them in resistance to heat and to mechanical injuries.

The observation has been often made, that out of a lot of negatives made at the same time, and varnished with the same varnish, and kept under identical conditions, some will be ruined with honeycomb cracks and others escape, and this fact has occasioned much surprise, and has remained unexplained. The writer is satisfied, from his examination, that the explanation is very simple.

Varnish penetrates but slowly through a collodion film, and if it is poured off too soon, the negative may appear to be all right, and yet the varnish have really no sufficient hold upon the glass. The importance of this point has, the writer believes, never before been pointed out. In the directions for varnishes given in this manual, it is advised to wait ten or twelve seconds *after the plate is completely covered*, before *commencing* to pour off. This gives the varnish time to completely saturate the film and to cover the glass under the film with an even stratum. Attention to these directions is important, especially for those who wish to feel that their negatives are safe for a long period of years.

It seems scarcely necessary to say that if the hyposulphite has not been thoroughly washed out, the dangers to the negative are thereby much aggravated. Experience is also constantly accumulating to show that when negatives have been carelessly varnished, or where a poor varnish has been used, any sudden change of hygrometric condition may cover the negative with honeycomb cracks. A case has been cited in which a negative in good condition was taken from a warm, dry room and carried for half an hour through a damp atmosphere, at the end of which time it was covered with cracks. With any of the above four varnishes properly applied, it is safe to say that such a trial might have been repeated a score or perhaps a hundred times without evil results.

When this trouble occurs, the writer would advise to revarnish with a thin spirit varnish, leaving it in for twenty or thirty seconds before commencing to pour off. In his own work he has never met with a single case of cracking.

Reducing Residues.—Lately the plan of precipitating silver as oxalate and reducing by heat, has been brought forward again. The idea is ingenious, and as oxalate of silver is easily resolved into metallic silver by the simple application of heat, the method would be convenient enough, were it not so dangerous. The oxalate of silver, when heated, is liable to explode with tremendous violence; an accident of this sort happened some years ago in the laboratory of M. Wurtz, in Paris.

New Developer.—It is stated that the action of pyrogallie acid as a developer is greatly heightened by the addition of sulphate of copper. A three-grain solution of pyrogallie acid is mixed with one-third of its bulk of a cold saturated solution of sulphate of copper just before throwing it over the plate.

INDEX.

A.

Aberration, 58, 59
Accessories, 203
 arrangement of, 189
Acceleration of exposures, 220
Acetate toning, 290
Adapting flanges, 224
Admission, centre of, 69
After-intensification, 171
Alabastrine positives, 189
Albertype, 394
Albumen positives on glass, by development, 387
 by sun printing, 391
Albumenizing glass, 155
 paper, 270
Alcohol, influence of, 131
Alkaline carbonate toning, 289
 development, 358
Alum in the printing bath, 274
Ambrotypes, 42, 188
Aniline process, 396
Animals photographed, 349
Annatto for backing, 356
Anthony, H. T., alum in printing bath, 274
 fuming, 279
Aplanatic lens, 10, 81
Apparent size of objects, 106
Architectural photography, 208
Arrangement of accessories, 191
Arrowroot paper, 272
Astigmatism, 61
Atmospheric effect, 244

B.

Backgrounds, 203
 canopy, 204
 conical, 205

Backgrounds—

 crayon, 208
 inclined, 204
 pictorial, 208
 rotating, 206
Backing dry plates, 356
Balance, 421
Bar frame, 45
Barrel distortion, 65
Bases in collodion, 134
Bath, fixing, 46
 negative, 19, 155
 positive, 44
 printing, 273, 274
 swinging, 158
 toning, 46
Bending glass, 427
Benzoate toning, 290
Berlin portraits, 194, 283
Blackening brass and wood surfaces, 428
Blistering in dry plates, 352
 silver prints, 341
Blotting off silvered paper, 274
Blue stippling, 121
Blurring, 27, 315
Brass surfaces, to blacken, 428
Brilliance, how obtained, 231
Bromide of ammonium, 134
 of cadmium, 136
 of lithium, 135
 of potassium, 134
 of sodium, 135
Bromides in collodion, 137, 168
Buckle's brush, 429

C.

Calcio-chloride toning, 289
Camera, landscape, 147
 levelling the, 147

Camera—

- red lining to, 221
 - reversing of, 148
 - selection of, 12, 147, 221
 - solar, printing by, 268
 - tested, 13
 - for transparencies and opalotypes, 384, 385
 - Van Monckhoven's, 266
 - Woodward's solar, 266
- Canopy background, 204**
- Carbon printing, 298, 402**
on glass, 403
- Carbonate of silver, printing on, 282**
- Carriers, 14**
- Centre, admission and emission, 69**
optical, 68
- Chemicals, 15**
in fault, 304
- Chemical focus, 95**
- Chloride of iron, printing with, 398**
of silver, development on, 160
- Chlorine, intensifying by, 172**
- Chromatic aberration, 59**
- Cleaning, 35**
glass, 426
- Cleanliness, 17**
- Clouds, 219, 239**
printed in, 184
reflected, 185
- Clove process, 373**
- Coating the plate, 23**
- Coffee process, 371**
- Collo-developers, 164**
- Collo-dio-bromide process, 365**
- Collo-dio-chloride process—**
failures in, 242
on glass, 388
on paper, 391
- Collodion, 131, 231, 305**
decanting, 145
dry plate, 365
filtering, 146, 367
formulas for, 142, 143
injurious to health, 416
keeping of, 146
salting, 132, 134
thinning, 25
- Colors obtained in photography, 414**

- Coma, 63**
- Comets, 324**
- Combination prints, 182**
- Composition, 234**
- Conical background, 204**
- Conjugate foci, 75**
- Contact printing on glass, 386**
- Contrast, causes of, 165, 313**
in composition, 243
- Contrasts, 213**
- Copying, 251**
camera, 253, 255
cone, 253
- Corks, to pierce, 427**
to soften, 427
- Corrosive sublimate for intensifying, 172**
- Corrosive sublimate, poisonous effects of, 417**
- Cotton, negative, 126**
- Crapy lines, 310**
- Crayon portraits, 194**
- Cross-lights, 193**
- Creamy negatives, 161**
- Curvature of the field, 63**
- Cut-off, 15**
- Cyanide for intensifying, 173**
poisonous nature of, 416

D.

- Daguerreotypes, copying of, 254**
- Dark room, 109**
arrangement of, 111
temperature, 113
- Decantation, 426**
- Defects in the image, 313**
- Developers, Collo-, 164**
strong and weak, 162
sugar, 164
- Developing boxes, 346**
- Development, 30, 132, 162, 305**
aids to, 162, 163
alkaline, 358
of dry plates, 358
management of, 165, 166, 198,
200, 214, 318, 432
on paper, 260
- Diagonal line, the, 236**
- Diaphragms, 64, 92**
inclined, 66, 219

Difficulties in portraiture, 198
 Dippers, 25
 Direction, line of, 234
 Dispersion, 54
 Distance in landscape composition, 238
 Distance of position, 191
 Distortion, 65
 Double portraits, 181
 Drawings, copying of, 251
 Dress, effect of, 196
 Dry plate photography, 351, 365
 plates, to dry, 353
 backing of, 356
 development of, 358
 failures in, 360
 Drying box, the author's, 354
 Drying dead, 330
 Drying plates by heat, 353
 spontaneously, 356
 by sulphuric acid, 354
 Dust, 160

E.

Edging plates, 352
 Emission, centre of, 69
 Enamels burned in, 392
 Encaustic paste, 300
 Engravings, copying of, 251
 Enlargements, 177, 265
 Equivalent focus, 70
 Ether, influence of, 131
 injurious effects of, 415
 Evaporating, 423
 Exposure, 30, 195
 acceleration of, 220
 of dry plates, 361, 363

F.

Failures in dry plate work, 360
 in photographic operations, 301
 in silver printing, 337
 in varnishing, 40, 330
 Faults in spherical lenses, 58
 Feathery markings, 330
 Fennemore's glass room, 118
 Ferrotypes, 42, 188
 Field work, 222
 Figure, relative size of, 192

Figures in landscapes, 241
 Filtering collodion, 146, 367
 Filtration, 423
 Fixing the print, 293
 Fixing bath, 46
 Flanges, 96, 224
 Flare, 91
 Flat pictures avoided, 199
 Focal lengths of lenses, 66
 determined, 70, 72, 73, 74
 Foci, conjugate, 75
 Focus, chemical, 95
 equivalent or absolute, 70
 Focussing, 28, 224
 Fogging, 302
 of dry plates, 362
 sources of, 112, 113
 Foliage, 219
 Foreground in landscapes, 219, 237
 Fuming, 279
 Fusing residues, 424

G.

Gallate of lead, 261
 Ghost in the camera, 91
 Ghosts, 181
 Glass, cleaning of, 17, 155
 for glass house, 115
 ground, 48, 121
 preparing of, 155
 selection of, 154
 Glass room, 115
 Globe lens, 85
 Glycerine and honey process, 350
 Gold, chloride of, a poison, 418
 Gold residues saved, 381
 Groups, 120, 192, 248
 Granularity in negatives, 310
 Green color, its actinic value, 139
 Ground glass, printing under, 180, 283
 Gum in dry plate work, 365
 Gum-gallic process, 374
 Gurney's glass room, 119

H.

Halation, 315
 Half-tone, how obtained, 167, 315

Harsh pictures avoided, 199
 Health, 415
 Heat in development, 359
 Heating, 422
 Heliochromy, 414
 Holders, pneumatic, 159, 160
 Horizon in landscapes, 242
 Hyposulphite of sodium, testing for, 297

I.

Illumination, 201
 Image defective, 313
 nature of, 97
 Inclined backgrounds, 203, 204
 Index of refraction, 54
 Instantaneous photography, 347
 Intensifying negatives, 171, 172, 173
 Intensity, falling off of, at edges, 65
 Iodides in collodion, 137
 Iodine for intensifying, 171
 Irregularity of film, 310
 Iron, printing with salts of, 397
 Ivory, miniature effects on, 390

J.

Jamin lenses, 80

L.

Landscape lenses, 9, 91
 photography, 11, 51, 208, 224
 Legray's process, 264
 Lenses, aplanatic, 10, 81
 Blunt's hemispherical, 88
 care of, 96
 centering of, 93
 comparison of, 92
 focal lengths of, 66
 general remarks on, 90
 globe, 85
 images of, 97
 Jamin, 80
 nature of, 56
 orthoscopic, 87
 Pantoscope, 88

Lenses—

 portrait, 79
 quickness of, 95
 rapid rectilinear, 9, 81
 rectilinear, 88
 Ross's doublet, 87
 selection of, 9, 93
 triplet, 83
 view, 9, 78
 Zentmayer, 86

Levelling the camera, 29, 209

Liesegang, toning formula, 291

Light, exclusion from lens, 120

 influence of, 250

 insufficient, 202

 management of, 193, 200

 regulation of, 109, 124

Line engravings, copying of, 251

Lines in the negative, 326

Lithographs, copying of, 251

Local redevelopment, 169

 reduction of negatives, 176

Loescher & Petzch's glass room, 119

Lumps in the film, 311

M.

Magnesium light, negatives by, 185

Management of light, 193

Manipulations, 420

 in the field, 222

Marbled stains, 327

Materials for landscape work, 221

Measuring, 422

Meicke's experiments, 275

Melainotypes, 189

Mercury for intensifying, 172, 174

Metrical weights, 421

Mezzotint prints, 194, 283

Mezzotints, copying of, 251

Microphotography, 258

Microscopic photography, 259

Miniature effects on ivory, 390

Minim glass, 422

Miscellaneous faults, 333

Moonlight effects, 181

Morphia process, 374

Mottling in the negative, 312

Mounting prints, 299

N.

- Negative, the, 147, 158
 artifices with, 181
 bath, 19, 155, 304
 development on paper, 263
 drying of, 37
 for enlargement, 177
 influences on, 167
 intensifying of, 171, 172, 173, 174
 by magnesium light, 185
 marking of, 426
 paper pasted on, 180
 printing of, 280
 reducing of over-developed, 176
 locally, 176
 retouching, 178
 reversed, 400
 scarlet, 173
 storing of, 186
 thin, how printed, 281
 varnished, to intensify, 175
 varnishing of, 37, 375, 431
 washing of, 36
- Neutralization, 425
- Nitrate of silver, fused, 157, 305
- Nitric acid, poisonous effects of, 418
- Nitroglucose, 268
- Notman, toning formula, 290

O.

- Objectives, 9
- Oil paintings, copying of, 251
- Opalotypes, 383
- Optical centre, 68
- Orthoscopic lens, 87
- Out-door photography, 344
- Oxalotype, 398
- Oyster-shell markings, 327

P.

- Pads, 45
- Pad fuming, 279
- Panoramic camera, 88
- Paper, albumenizing, 270
 arrowroot, 272
 enlargements, 265

Paper—

- negatives, 263
 for positives, 269
 sensitizing of, 273
- Papyroxyline, Liesegang's, 129
- Paraffining, 264
- Paste, 428
 encaustic, 300
- Pencil drawings, copying of, 251
- Percolator, 429
- Permanence of silver prints, 300
- Permanganate of potassium, 174
- Perspective, atmospheric, 244
 incorrect, 103
 photographic, 97
- Photogalvanography, 395
- Photography, architectural, 208
 landscape, 208
- Photographs, copying of, 254
- Photolithography, 394
- Pinholes, 321
- Plans, copying of, 255
- Plate boxes, 187
- Plates, preserved, 350
 sensitive, keeping of, 344
- Pneumatic holders, 159, 160
- Poisons, 415
- Portrait lenses, 10, 79
- Portraiture, 90, 106, 190, 247
- Posing the sitter, 197
- Position of background, 206
 in landscape work, 240
- Positive bath, 44, 273
- Positive paper, new method of preparing a paper that will keep, 277, 431
 paper, washed, 275
 printing, 269, 280
- Positives, alabastrine, 189
- Pouncy's carbon process, 402
- Pouring, 424
- Preservatives for dry plates—
 clove, 373
 cochineal, 370
 coffee, 371
 gum gallic, 374
 morphia, 374
 pyrogallic, 369
 resin, 373
 tannin, 371
 tea, 371

Pressure frame, 283
 Printing, 280, 284
 Printing bath, 273
 new, for permanent paper,
 277, 431
 Printing in the camera, 384
 Printing in clouds, 184
 Printing, failures in, 336
 frames, 45, 283
 on glass by development, 383
 silver, 269
 Prints, combination, 182
 finishing the, 298
 mounting of, 299
 rolling the, 300
 silver, permanence of, 300
 tested if well washed, 297
 Projection, panoramic, 108
 plane, 106
 Pyrogallic preservative for dry
 plates, 369
 Pyroxyline, 126
 alcoholic, 130
 influence of, 130
 treatment with alkali, 132
 variable character of, 168

R.

Rapid rectilinear lens, 9, 81
 Red lining to camera, 220
 Redevelopment, 32
 local, 169
 Reducing over-developed nega-
 tives, 176
 Reflectors, 124
 Reflection, 52
 Refraction, 52
 Relievo process, Woodbury's, 396
 Rembrandt effects, 194
 Remedies for poisoning, 418
 Repeating back, 191
 Repetition in composition, 243
 Residues, treatment of, 379, 432
 Resin process, 373
 Retouching the negative, 178
 Retouching, use of resin in, 379
 Revarnishing, how to do, 41
 Reversed negatives, 400
 Ridge roof, 115
 inclination of, 117

Rolling prints, 300
 Ross's doublet lens, 87
 Rotating background, 206
 Rubber varnish, 352
 Rules, general, 47

S.

Salomon's glass room, 120
 Sarony's glass room, 119
 Scarlet negatives, 173
 Schlippe's salt, 173
 Seasons, influence on landscape
 work, 227
 Sensitizing paper, 44, 273
 new method, 277, 431
 Serum of milk, 264
 Shade printing, 280
 Shadows, 216
 Sharpness, want of, 317
 Shepard, Dr., toning formula, 291
 Silver, bromide of, 410
 chloride of, 406
 iodide of, 406
 prints, permanence of, 300
 pure, value of, 157
 Sizing the film, 177
 Skies, management of, 210, 219, 230
 Sky shade, 219
 Slides, 221
 Sliding front, 29
 Slipping of film, 317
 Smeariness of film, 320
 Snow landscapes, 215
 Softness, 231
 how obtained, 165
 Solar cameras, 266
 Sore hands, to heal, 37
 Specks in the film, 160
 Spherical aberration, 58
 Splitting of film, 316
 Spots, hazy, 323
 opaque, 324
 transparent, 321
 Stains, 14, 43, 327
 Stand, 15
 Steinheil aplanatic, 10, 81
 Stereopticon slides, 386
 Stereoscope, 256
 Storing negatives, 186
 Stopping out, 150

Stops, 92, 211, 223
 Streaks in the negative, 31, 320
 Sugar in development, 165
 Sulphide of potassium for intensifying, 172
 Sun printing, 280
 Sunlight in glass room, 122
 Surface stains, 327
 Swan's carbon process, 399
 Swing-back, 148, 223, 225
 use in landscape work, 151
 portraiture, 130
 Swinging bath, 158
 lens, 131
 Syrup for keeping negatives moist, 347

T.

Tank, washing, 295
 Tannin process, 371
 Tea process, 371
 Temperature of glass room, 123
 Tents, 346
 Theoretical considerations, 404
 Thinness of film, 310
 Tissue, carbon, 399
 Toning, 232, 288
 bath, 46
 formulae, 289, 290, 291
 and fixing baths, 292
 Top-light, excess of, 201
 Transparencies, 386
 Triplet lens, 83
 Tripod, how made, 221
 chemical, 423
 Tunnel system, 124
 Two-bath system, 155

U.

Uranium intensifying, 174
 Unsatisfactory results in portraiture, 200

V.

Varnish, 37
 effects of too thin, 41, 432

Varnish—
 India-rubber, 352
 negative, 375, 431
 Varnishing, 37, 38, 431
 failures in, 40, 41, 330, 432
 Veiling, 302
 Velvet drapery, 194, 197
 Ventilation, 28, 110, 121
 box, 111
 View lens, 9, 78
 Vignetting with cotton, 286
 by development, 287
 with a frame, 285
 glasses, 285
 with a lens, 287
 on the negative, 287
 with paper, 286
 by a screen, 288
 Viscid liquids, to filter, 429

W.

Washed sensitive paper, 275
 Washing the negative, 36, 169
 prints, 46, 295
 Washing tank, 295
 Wax-paper process, 264
 Weakening of negatives in fixing, 330
 Weather, indications of, 229
 Weighing, 420
 Weights, 421
 Wenderoth's glass room, 118
 Willis's aniline process, 396
 Wind, the, 226, 229
 Wood-cuts, copying of, 251
 Wood surfaces, to blacken, 428
 Woodbury's relieve process, 396
 Woodward, Dr., microscopic photography, 259
 Woodward's camera, 266

X.

Xyloidine, 130

Z.

Zentmayer lens, 86

THE NEW YORK PUBLIC LIBRARY
REFERENCE DEPARTMENT

This book is under no circumstances to be
taken from the Building

DEC 15 1910		
MAY 11		
AUG 3 1911		

BID AUG 3, 1940

