



UNIVERSAL  
LIBRARY



127 279

UNIVERSAL  
LIBRARY







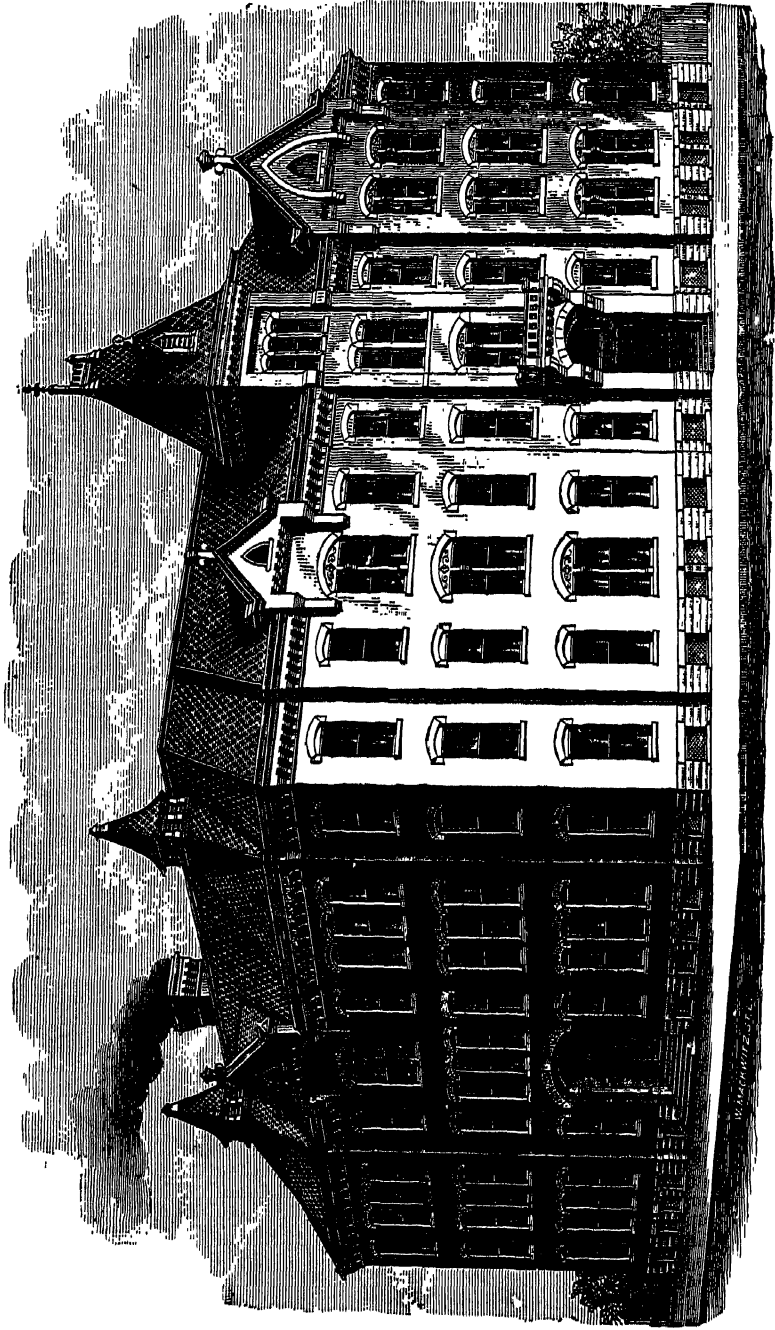

THE ST. LOUIS MANUAL TRAINING SCHOOL.

THE  
MANUAL TRAINING SCHOOL,  
COMPRISING A FULL STATEMENT OF  
ITS AIMS, METHODS, AND RESULTS,  
WITH FIGURED DRAWINGS OF  
SHOP EXERCISES IN WOODS AND METALS.

BY

C. M. WOODWARD, A.B. (HARVARD), PH.D. (W. U.),

ASSOCIATE AMERICAN SOCIETY CIVIL ENGINEERS, MEMBER AMERICAN SOCIETY  
MECHANICAL ENGINEERS, THAYER PROFESSOR OF MATHEMATICS AND  
APPLIED MECHANICS, DEAN OF THE POLYTECHNIC SCHOOL,  
AND DIRECTOR OF THE MANUAL TRAINING SCHOOL,  
OF WASHINGTON UNIVERSITY, ST. LOUIS, MO.

“Hail to the skillful, cunning hand!  
Hail to the cultured mind!  
Contending for the world's command,  
Here let them be combined.”

BOSTON :  
D. C. HEATH & CO., PUBLISHERS.  
1887.

COPYRIGHT, 1887,  
By C. M. WOODWARD.

RAND AVERY COMPANY,  
ELECTROTYPERS AND PRINTERS,  
BOSTON, MASS.



## PREFACE.

---

THIS book really consists of four Parts ; namely :—

I. The Historical Introduction and Chap. XIV.

II. The exposition of the methods and scope of the school, with full details as regards the manual elements, in Chaps. II., III., IV., and XV.

III. The results of manual training, as shown by the records and testimony of graduates and others, in Chaps. V. and VI.

IV. Discussions of the educational, social, and economic bearings of manual training from various standpoints and at various times, in Chaps. VII. to XIII.

It is possible that this classification may be of value to those who come for suggestions in specific directions. To others the arrangement may appear illogical, and the repetitions unnecessary.

In defence of the arrangement I must say that I have had in mind two things : *first* and foremost, the probable state of mind of the reader who comes to this book to learn of a matter of which he has heard much, but knows little. He wants facts, arguments, and speculations, according to the stage of his progress in finding out what manual training really is, and what it aims at. And secondly, the desirability of showing clearly the growth and progress of ideas in the development of the school.

As to the occasional repetitions of statements and arguments, I will say that no one is likely to read the book through consecutively. Those who do me the honor to read it at all will read by topics and separate chapters, and being thus read I doubt if the repetitions will be found objectionable. Of necessity, much common material appears in every address. The earlier addresses were quite general in their treatment, and I have preferred to let them stand fairly complete.

I trust no apology will be necessary for inserting addresses which, in one form or another, have already appeared in print. The discussions they contain relate to matters which are still of first importance and general interest, and I have felt that I could not

greatly improve upon the form in which they were originally presented. They contain my observations and reflections while actually engaged in daily supervision of a manual training school. They are therefore personal in character and positive in tone. I insert them because I have reason to believe that they may still be of service to those whose opportunities for testing theories have been less fortunate.

The critical reader may find me inconsistent in addresses several years apart. If so, I beg him to remember that I have not stood still the past fifteen years during which I have been in contact with advanced ideas on education and experimenting with manual methods.

I am well aware that many will be disappointed that I do not enter in detail into the theory and practice of manual training in the primary and grammar schools. To such I give the following reasons for having limited myself to the training of pupils of from fourteen to eighteen or more years: —

1. To have covered the whole field, even had I been able to do it, would have obliged me to make a book much too large. Very few persons would have been equally interested in the higher and the lower grades, and a separation of the parts would have been necessary.

2. The manual training of the lower grades has already been quite fully treated by others, while the ground I go over has scarcely been touched by a practical teacher. It must suffice if I mention the work of Prof. Strait, the reports of Dr. Felix Adler, the recent publications of Prang & Co., and more recently, the manual of Superintendent S. G. Love.

3. While I have very positive ideas about the methods which should be employed to train the pupils of the lower grades, I have had no experience in applying them. I therefore consider myself incompetent to speak with authority in regard to the details of the instruction. We have already had too many mere theorizers.

I bow reverently before those who not only have enlightened ideas, but who have thoughtfully, intelligently, and repeatedly put them to the test of actual use. For such I ask respectful consideration at the hands of parents and teachers; for myself and my work in my own field, I ask neither more nor less.

C. M. WOODWARD.

## CONTENTS.

CHAPTER	PAGE
I. HISTORICAL INTRODUCTION . . . . .	1-15
II. THE FIRST YEAR OF THE MANUAL TRAINING SCHOOL . . . . .	16-72
III. THE SECOND YEAR OF THE MANUAL TRAINING SCHOOL . . . . .	73-125
IV. THE THIRD YEAR OF THE MANUAL TRAINING SCHOOL . . . . .	126-149
V. THE RECORDS AND TESTIMONY OF GRADUATES . . . . .	150-167
VI. WHAT OTHERS WHO HAVE SEEN IT SAY OF THE RESULTS OF MANUAL TRAINING . . . . .	168-180
VII. THE COMPLEMENTARY NATURE OF MANUAL TRAINING. ( <i>Saratoga Address of 1882</i> ) . . . . .	181-201
VIII. THE FRUITS OF MANUAL TRAINING. ( <i>Saratoga Address of 1883</i> ) . . . . .	202-213
IX. MANUAL TRAINING A FEATURE IN GENERAL EDUCATION. ( <i>Philadelphia Address of 1885</i> ) . . . . .	214-239
X. THE ORIGIN, AIMS, METHODS, AND DIGNITY OF POLYTECH- NIC TRAINING. ( <i>St. Louis Address of 1873</i> ) . . . . .	240-260
XI. MANUAL EDUCATION. ( <i>St. Louis Address of 1878</i> ) . . . . .	261-288
XII. EXTRACTS FROM THE PROSPECTUS OF 1879 . . . . .	289-296
XIII. THE PROVINCE OF PUBLIC EDUCATION. ( <i>Chicago Address of 1887</i> ) . . . . .	297-326
XIV. EUROPEAN SCHOOLS . . . . .	327-334
XV. PLANS, SHOP DISCIPLINE, TEACHERS, REPORTS, ETC. . . . .	335-350

## APPENDICES.

I. ST. LOUIS MANUAL TRAINING SCHOOL COURSE OF STUDY . . . . .	351
II. TOLEDO MANUAL TRAINING SCHOOL COURSE OF STUDY FOR GIRLS . . . . .	352-353
III. DAILY PROGRAM OF THE TOLEDO HIGH AND MANUAL TRAINING SCHOOL . . . . .	354
IV. MANUAL TRAINING IN THE HIGH SCHOOL. ( <i>Address of Gen. Francis A. Walker at Chicago, 1887</i> ) . . . . .	355-357
V. MANUAL TRAINING IN SCHOOL EDUCATION. ( <i>By Sir Philip Magnus</i> ) . . . . .	358-360



# THE MANUAL TRAINING SCHOOL.

---

## CHAPTER I.

### HISTORICAL INTRODUCTION.

#### THE GROWTH OF THE MANUAL ELEMENT IN EDUCATION.

IN speaking of the "Aims, Methods, and Results of Manual Training," I shall not hesitate to refer freely to the Manual Training School of Washington University of St. Louis. I do not assume that it is perfect, but it appears to me that its methods are more matured, its theories more thoroughly reduced to practice, and its appliances more complete than in any other school I know. No one knows better than I our failings, nor does any one feel more strongly the necessity for continued improvement in the working details of our school. Nevertheless, the school comes nearer to my ideal than any other that I know.

I shall therefore give our methods and results as those most likely to be of use to others, tho I shall not fail to draw from other sources whatever shall appear to add to the value and completeness of my exposition.

For the sake of giving honor where honor is clearly due, the following brief sketch of the origin and growth of the Manual Element in Education is given.

In 1865 John Boynton of Templeton, Mass., gave \$100,000 for the endowment and perpetual support of a Free Institute for the Youth of Worcester County, Mass. He thus explained

his objects: "The aim of this school shall ever be the instruction of youth in those branches of education not usually taught in the public schools, which are essential and best adapted to train the young for practical life;" especially such as were intending to be mechanics, or manufacturers, or farmers.

In furtherance of this object, ten months later, in 1866, Ichabod Washburn of Worcester gave \$25,000, and later \$50,000 more to erect, equip, and endow a machine-shop which should accommodate twenty apprentices and a suitable number of skilled workmen to instruct them and to carry on the shop as a commercial establishment.

The apprentices were to be taught the use of tools in working wood and metals, and to be otherwise instructed, much as was customary fifty years ago for boys learning a trade.

The Worcester Free Institute was opened for students in November, 1868, as a technical school of about college grade; and the use of the shops and shop instruction was limited to those students in the course of mechanical engineering. Thus did the Worcester School under the leadership of Prest. C. O. Thompson incorporate tool-instruction and shop-practice into the training of mechanical engineers. Its pupils were all over sixteen years of age and its methods of tool-instruction were those of ordinary commercial shops. It was in fact the combination of the ordinary European engineering school with an ordinary machine-shop.

In the same year, 1868, Victor Della-Vos introduced into the Imperial Technical (engineering) School at Moscow the Russian method of class-instruction in the use of tools. Here the students were eighteen years old on admission, and all were to become government engineers. The great value of the work of Della-Vos lay in the discovery of the true method of tool-instruction, for without his discovery the later steps would have been impossible.

In 1870, under the direction of Prof. Robinson and Prest. J. M. Gregory of the University of Illinois, a wood-working shop was added to the appliances for the course in architecture, and an iron-working shop to the course in mechanical engineering in that institution. In 1871, the Stevens Institute of Hoboken,

N. J., munificently endowed by Edwin A. Stevens, as a school of mechanical engineering, fitted up a series of shops for the use of its students.

The next step forward was taken by Washington University in St. Louis in providing for all its engineering students systematic instruction in both wood and metals. In 1872, a large shop in the Polytechnic School was equipped with workbenches, two lathes, a forge, a gear-cutter and full sets of carpenters', machinists', and forging tools. The first work undertaken, was the construction of models for the illustration of mechanical principles. The inability of the students to use the tools with any facility soon led to the introduction of exercises for the sole purpose of tool-instruction. Thus unconsciously we were following in the steps of Della-Vos. This work was so far systematized as to be reported as follows in the University Catalogue of 1875:—

“During the past year the students of each class [the four polytechnic classes being required to attend without regard to their course of study, while the classical students were at liberty to attend] have worked systematically in the shop under the direction of the professors, assisted by a skillful carpenter and a pattern-maker. The general method of conducting this work is as follows: A sketch of the piece or task to be constructed is given a class with all needed dimensions. Each student then makes a careful drawing of it to some convenient scale, with details and exact measurements.

“The class then goes to the shop, is furnished with the requisite materials and tools, and each member is shown by an expert how to execute the work. Every piece must be reasonably perfect or it is rejected and a new one is required. Although the students work in the shop no more than four hours per week, the experience is valuable. It is not supposed of course that skilled work can be produced by this method, but it is certain that such training will make better judges of workmanship.”

Thus far had we progressed when the Philadelphia Exposition of 1876 was opened.

None of us knew any thing of the Moscow school, or of the one in Bohemia in which the Russian method had been adopted in 1874. The Russian exhibit at Philadelphia was less of a surprise to me than to many. It showed with remarkable fullness and logical arrangement the true educational method

of tool-instruction. It presented, clear-cut and definite, what before had been ill defined or unthought of. Before referring to the great work of Prof. Runkle in presenting the Russian method to the American people, I will give the story of our first series of workshops in the old "Philibert Mansion" on the ground where the University gymnasium now stands.

In the summer of 1877, having outgrown our single shop, we transformed an old dwelling-house into shops, using the chambers for a carpenter-shop, the parlors for a machine-shop, and the basement for a forging-shop.

The Freshmen had benchwork in wood, the Sophomores wood-turning, the Juniors metal turning and fitting, and the Seniors forging. At that time, I wrote as follows in reference to Mr. Gottlieb Conzelman who had given the money for fitting up those shops:—

"I feel so sure that from this small beginning important consequences are to follow, that I almost envy Mr. Conzelman the satisfaction he will certainly feel in having contributed to its foundation."

For three years, with no essential change of plan, the shops were used. The instruction was very general, and our success with the polytechnic students and a class of thirty boys from Smith Academy of preparatory grade pointed out the way for the MANUAL TRAINING SCHOOL, whose building was erected in 1879, and which was opened in September, 1880.

In his report of 1876, Prest. J. D. Runkle, of the Mass. Institutè of Technology, gave a full exposition of the theory and practice of tool-instruction of Della-Vos as exhibited at the Philadelphia Exposition, and he recommended that without delay the course in mechanical engineering at the Institute be completed by the addition of a series of Instruction Shops. The suggestion was acted on, and in the spring of 1877 a class of mechanical engineering students was given instruction in chipping and filing. In his report of 1877, Prest. Runkle announced his shops as "near completion."

For this vigorous action, and above all for his appreciative reports on the Russian methods, Prest. Runkle deserves the praise of American educators. Mr. Runkle looked deeper into



the problem than had Della-Vos; he saw that shop-instruction, essential to a mechanical engineer, had elements of value in a general education.

The School of Mechanic Arts is a sub-department of the Institute. It was established by vote in 1876 and opened in 1877.

It has a two-years' course of study and is open to boys not less than fifteen years of age. I am not aware of its being regarded as in any respect a preparatory school for the Institute proper, or for any college course, though the training is exceedingly general in its bearing.

The St. Louis Manual Training School was established June 6, 1879. It embodied hopes long cherished, and plans long formed.<sup>1</sup>

For the first time in America the age of admission to school-shops was reduced to fourteen years as a minimum, and a very general three-years' course of study was organized. The ordinance by which the school was established specified its objects in very general terms: —

“Its objects shall be instruction in mathematics, drawing, and the English branches of a high-school course, and instruction and practice in the use of tools. The tool-instruction, as at present contemplated, shall include carpentry, wood-turning, pattern-making, iron clipping and filing, forge-work, brazing and soldering, the use of machine-shop tools, and such other instruction of a similar character, as it may be deemed advisable to add to the foregoing from time to time.

“The students will divide their working hours, as nearly as possible, equally between mental and manual exercises.

“They shall be admitted, on examination, at not less than fourteen years of age, and the course shall continue three years.”

Another article is as follows: —

“For every sum of \$1,500 contributed for the establishment or permanent endowment of said school, the donor shall be entitled to a certificate of scholarship under which he shall have the right to send one scholar to said Manual Training School free of tuition charges, so long as said school shall exist.”

For the sake of showing that our general plan and policy were fully outlined at that time, I give some extracts from our Prospectus published in 1879: —

---

<sup>1</sup> See Chap. X. for Address of 1873.

"The management of this school does not propose that its shops shall enter into competition with manufacturing establishments. Proprietors of machine-shops and factories need not look upon this institution as a rival.

"In the next place, the scope of a single trade is too narrow for educational purposes. Manual education should be as broad and liberal as intellectual. A shop which manufactures for the market, and expects a revenue from the sale of its products, is necessarily confined to salable work, and a systematic and progressive series of lessons is impossible.

"If the object of the shop is education, a student should be allowed to discontinue any task or process the moment he has learned to do it well. If the shop were intended to make money, the students would be kept at work on what they could do best, at the expense of breadth and versatility." *Prospectus, p. 17.*

"One great object of the school is to foster a higher appreciation of THE VALUE AND DIGNITY OF INTELLIGENT LABOR, and the worth and respectability of laboring men. A boy who sees nothing in manual labor but mere brute force, despises both the labor and the laborer. With the acquisition of skill in himself, comes the ability and willingness to recognize skill in his fellows.

"When once he appreciates skill in handicraft, he regards the skillful workman with sympathy and respect."

"It is believed that, to all students, without regard to plans for the future, the value of the training which can be got in shop work, spending only eight or ten hours per week, is abundantly sufficient to justify the expense of materials, tools, and teachers." *Ibid, p. 10.*

In a four-page circular issued in the summer of 1880 before the new school was opened, occurred the following paragraph:—

"The Manual Training School is not a mere workshop; the head is to be trained even more than the hand. Specific trades will not be taught; the tool-education will be liberal, extending impartially through all the shops.

"It is not expected that every boy who attends the school will become a mechanic, but we have reason to believe that a boy's experience in the school will clearly indicate whether he is fit to become a mechanic or not."

In subsequent chapters I shall give the theory and organization of the school in detail.

At this point I will only give some personal matters relating to the origin of the school, and a summary of its history during the seven years it has completed.

In an essay on "Manual Education in the Polytechnic School," published October 1, 1877, I pointed out the features of a school that should give a general mechanical course.

Again, in 1878, before the St. Louis Social Science Association I said : —

“ The manual education which begins in the kindergarten should never cease. Just how we shall supply the missing links in the chain which joins the kindergarten with the fully equipped shops of the polytechnic school, we cannot with certainty suggest.

“ The problem is an open one, and thousands of earnest and intelligent educators are devoting themselves to its solution.

“ I trust that St. Louis will in this, as in many other educational matters, contribute largely. . . .

“ Girls should be taught [besides drawing] needle craft, and, in the higher grades, the elements of cooking. . . .

“ At ten years give boys knives and gauges and hammers and saws and squares. Let them carve in soft wood and plaster, and learn to strike true and square blows. At twelve they are ready to use the plane, the chisel, and the whole chest of tools. Until you reach machine tools, the shop outfit may be of the simplest character. Benches, vises and a half-dozen tools for each student in a class is all; the whole cost would hardly exceed that of the furniture in an ordinary schoolroom.”

These suggestions, coupled with statements and explanations of what was being done in Moscow, in Paris, in the Netherlands, and in Worcester and Boston, led Mr. Samuel Cupples to offer to assist in the establishment and support of a more elementary school in which manual training should be a prominent feature. He offered to give \$3,000 a year for five years for the current expenses of the school. Messrs. Edwin Harrison and Gottlieb Conzelman, both of whom had contributed to the shop outfit in the polytechnic school already referred to, agreed to co-operate. Dr. Eliot, chancellor of the University, presented the land; Mr. Harrison erected the building; Mr. Conzelman partially furnished it; and with Mr. Cupples to help meet its current expenses, the school was an assured fact.

In addition to these four men, fully twenty other people contributed sums varying from \$100 to \$2,000, to complete the equipment.

Such was the origin of the first real Manual Training School for students of intermediate grade. All other steps in the workshop direction had been with older students, and in strictly technical schools; or they had been, as in France and Belgium, “ trade ” schools. Here was a large school for general

education on a new and clearly defined plan, admitting boys as young as fourteen years.

The origin of the name is a matter of some interest. The author had already published two essays on "Manual Education,"<sup>1</sup> and the phrase "manual training" had been freely used. Without hesitation, therefore, he suggested "Manual Training School" as an appropriate name. At first the name did not commend itself to the chancellor of the University. It had a flavor of the army about it, he feared, and it failed to suggest the thoroughly intellectual nature of all the work. At the same time it was desirable to prevent any chance of confusing the school with a variety of "manual labor" schools which during the last fifty years had appeared in various parts of the country."

In spite of Shakespere, there is much in a name, and it was desirable that the name should not create a prejudice against the school. It is possible that the chancellor was right; it is certain that we have not escaped misapprehension and prejudice, tho correct ideas seem at last to prevail. The name appears to have been finally received with favor, and I doubt if the concession is to be regretted.<sup>2</sup>

The original Managing Board of the School consisted of Messrs. Edwin Harrison, John T. Davis, Henry W. Eliot, Samuel Cupples, and Gottlieb Conzelman. Since the organization of the school the following members have been added;— Messrs. William Brown, Ralph Sellew, and William L. Huse.

<sup>1</sup> The paper of May, 1878, printed by G. I. Jones & Co., St. Louis, was afterwards published by E. Steiger of New York.

<sup>2</sup> The writer has now in his possession the following list of suggestions handed him by Dr. Eliot with the statement that the last one was the least preferred.

PROF. WOODWARD.

*My dear Sir,*—I have thought over all the names, searched the dictionaries and etymologies, —but can only come back to what we once considered and rejected: MECHANICAL SCHOOL OF WASHINGTON UNIVERSITY.

It is better than: HAND-AND-HEAD-WORK SCHOOL, TECHNICAL SCHOOL, INDUSTRIAL SCHOOL, TRADE SCHOOL OF HAND-TRADE SCHOOL, SKILLED LABOR SCHOOL, SCHOOL OF INDUSTRIAL ARTS, or MANUAL TRAINING SCHOOL which I put last as being misleading and somewhat belittling.

Yours,

W. G. ELIOT.

The "Mechanic Art" School of Boston is still so named; and Mr. Courtlandt Palmer of the Grammercy Park School, New York, speaks of his "Tool-House."

The following condensed sketch of the progress of the school will suffice for general purposes.

The original building erected by Mr. Harrison at an expense of \$13,000 was 100 feet by 50 and 40, and fronted Eighteenth Street; it is well shown in the accompanying cut. [See next page, Fig. 2.] The third floor contained the study and recitation rooms; the lower stories, the shops.

With the exception of the engine and a supply of tools for the students of the engineering (polytechnic) school, the shops were furnished only as they were needed by the growing school.

The first year only wood-working facilities were needed; the second year, forging; and the third year, the fitting (machine) shop.

On September 6, 1880, the school opened with a single class of about 50 pupils. The whole number enrolled during the *first year* was 67. A public exhibition of drawing and shop-work was given June 16, 1881.

The *second year* of the school opened September 12, 1881, and closed June 14, 1882. There were two classes, 61 pupils belonging to the first year, and 46 to the second year, making 107 in all.

During the summer of 1882, the large addition fronting Washington Avenue was built and furnished. This addition cost, including the land, \$25,000. About \$5,000 was spent in additional tools, furniture and shop appliances.

By this extension the capacity of the school was nearly doubled, and its facilities were well balanced. The result is an exceedingly satisfactory arrangement for a school which must provide all the features of the daily program. The money for the large addition was furnished in equal parts by Messrs. Ralph Sellev and G. Conzelman. A view of the building is shown in the frontispiece, and the details of the floor plans are given later in the book.

The *third year* of the school opened September 11, 1882, and closed June 14, 1883, with the graduation of its first class. Twenty-nine young men received diplomas and medals. The enrollment for the year was 176.

The *fourth year* of the school opened September 10, 1883.

The enrollment for the year was 201. Twenty-nine students received diplomas in June.



FIG. 1. THE ORIGINAL MANUAL TRAINING SCHOOL BUILDING, ERECTED IN 1870.

The *fifth year* began September 8, 1884. The enrollment was 218. Thirty-nine students graduated at the end of the year.

During the year 1884, the school lost two of its best and earliest friends in the death of two of its managers, Ralph Sellev and Gottlieb Conzelman.

At the same time, through their liberality and the co-operation of Mr. Samuel Cupples, a member of the Managing Board from the first, an endowment of \$115,000 was secured to the school.<sup>1</sup>

The *sixth year* opened September 14, 1885. The enrollment for the year was 234. The number of students graduating was *forty-five*.

It is interesting to note that these forty-five, and one who remained to the end but failed to win a diploma, represent just 100 boys who during the three years had belonged to the class. The actual graduation of 45 per cent of those at any time belonging to the class may fairly represent the *tenacity* of our classes.

The *seventh year* closed on June 8, 1887 with the graduation of fifty-two boys. The enrollment of the year was 230.

#### MANUAL TRAINING ELSEWHERE.

The growth of manual training as shown by the establishment of other and similar schools has been most remarkable.

It is impossible for me to mention all, but a few deserve to be named. Nearly every polytechnic, agricultural and mechanical school in the country has shop-work incorporated in its technical courses. The manual training school proper is of lower grade, and far more general in its character.

The Baltimore Manual Training School, a public school, on the same footing as the high school, was opened in 1883.

---

<sup>1</sup> A few days before his death Mr. Sellew came to a definite agreement with Messrs. Cupples and Conzelman, to contribute \$25,000 in the course of five years, towards a permanent endowment for the School, the income of which should chiefly be used to secure the admission and instruction of worthy boys in straitened circumstances.

Although the agreement had not been recorded in legal form at the time of Mr. Sellew's death, it has since been fully executed, in accordance with the original intention, by Mr. T. G. Sellew, of New York, as the residuary legatee of the estate.

In memory of Ralph Sellew and of his profound interest and liberality towards the school, the Board of Managers adopted the following resolution on the 19th of February, 1884:—

“Resolved, That to perpetuate his (Ralph Sellew's) name and the memory of his good works, a gold medal, to be known as the ‘Sellew Medal,’ shall be awarded annually to that member of the graduating class who in the opinion of the teachers and committee stands highest in his class.”

The Chicago Manual Training School, established as an incorporated school by the Commercial Club of that city, was opened in January, 1884. The school is in a beautiful building, and is admirably equipped in every way. Under the able direction of Dr. H. H. Belfield it is deservedly popular. Its last catalogue

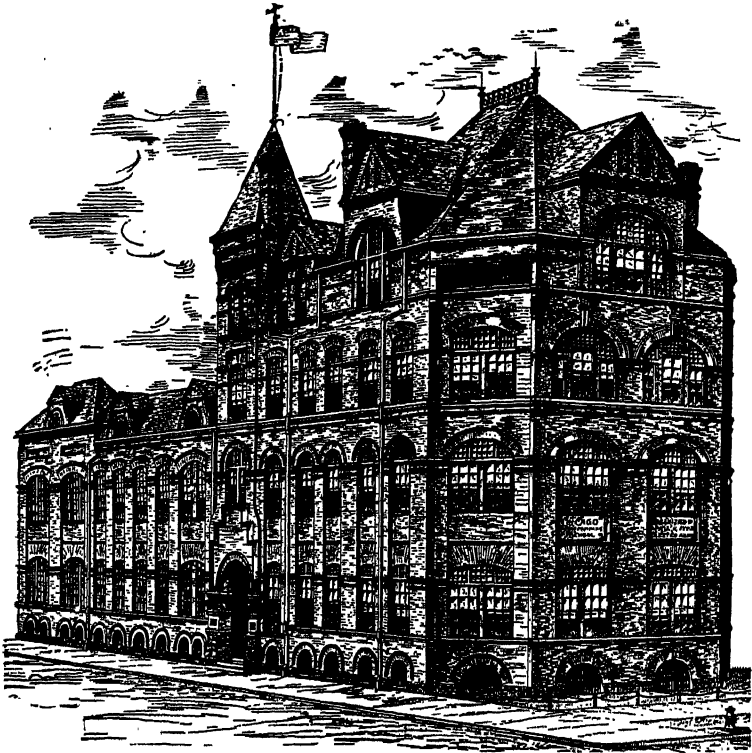

FIG. 2. CHICAGO MANUAL TRAINING SCHOOL.

shows a list of 190 students. Fig. 2 gives a view of the building of the Chicago school.<sup>1</sup>

Manual training was introduced into the high school of Eau Claire, Wisconsin, in 1884.

---

<sup>1</sup> For the record of its graduates see Chapter V.

The engraving of the Chicago Manual Training School, was made from a drawing of the building made by a pupil of that school from actual measurements made by himself.



The "Scott Manual Training School" was organized as a part of the high school of Toledo in 1884. A picture of the

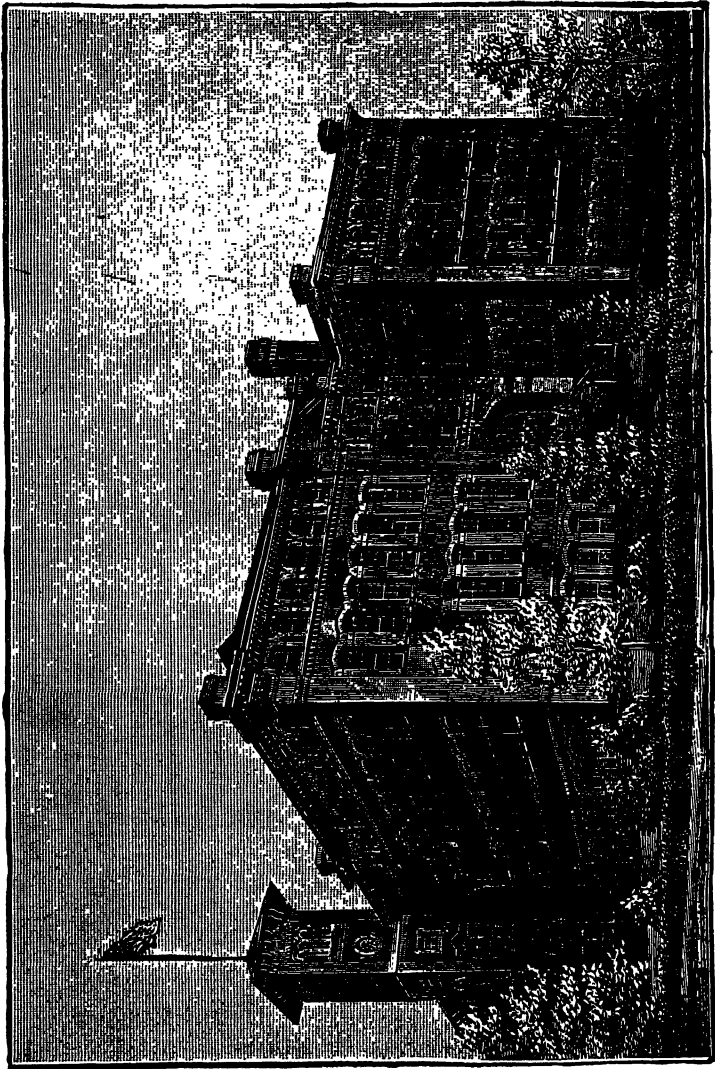

FIG. 3. TOLEDO MANUAL TRAINING SCHOOL.

manual portion of the building is shown in Fig. 3. For floor plans, etc., of the Toledo School, see Chapter XV.

Manual training was introduced into the College (high school) of the City of New York in 1884.

The Philadelphia Manual Training School, a public high school, was opened in September, 1885.

The Omaha high school introduced manual training in 1885.

The Grammercy Park Tool-House, New York City, was opened in 1884.

The Manual Training School of Denver University was opened in September, 1885, as a preparatory school. In 1886, tuition in it was made free to Colorado boys.

Dr. Adler's Workingman's School for poor children has for several years taught manual training to the very lowest grades.<sup>1</sup>

Swathmore College, near Philadelphia, has for two years had regular manual training.

The Cleveland Manual Training School was incorporated in 1885, and opened in connection with the city high school, in 1886.

New Haven, which had for some time encouraged the use of tools by the pupils of several of its grammar schools, in September, 1886, opened a regular shop and furnished systematic instruction in tool-work.

The school board of Chicago added manual training to the course of the "West Side High School" in September, 1886.

The "Technical School of Cincinnati" was opened in September, 1886. It is in all but the name a manual training school.

In a large range of public and private schools of still lower grades manual exercises of a rather fugitive character have been introduced, which may lead to the establishment of systematic tool and drawing instruction.

At the risk of appearing to overlook equally important movements elsewhere, of which I have little or no information, I will

---

<sup>1</sup> I have not space to give even a sketch of this most admirable school. Unlike the Manual Training School proper, it is a school for the youngest children. Its course of study ends at the age of fourteen, just when our school begins. For an exposition of its thoroughly philosophical and practical curriculum, I must refer the reader to the elaborate reports of Dr. Felix Adler. As a practical test of manual methods for children from the kindergarten age to the high school, it is worthy of the most careful study.

venture to name the very suggestive public school experiments in wood-work in Boston, Mass., and in Peru and Moline, Ill., in each case under the direction of the superintendent of public schools.

A preparatory department of Tulane University, New Orleans, known as the Tulane High School has been established as a regular manual training school. It is reported as in a very flourishing condition.<sup>1</sup>

What has been done in this direction is but a feeble indication of the profound interest prevailing. In every city the matter is under discussion, and in many steps have been taken towards a regular establishment. Another year will doubtless see public manual training schools in Boston, St. Paul, Minneapolis,<sup>2</sup> Louisville, San Francisco, and Milwaukee.

---

<sup>1</sup> Prof. J. M. Ordway, the director of the Tulane High School, was for some years in practical charge of the Mechanic Art School of the Massachusetts Institute of Technology, though filling the chair of Applied Chemistry.

<sup>2</sup> Since writing the above, manual training has been introduced into the high school of Minneapolis.

## CHAPTER II.

## THE FIRST YEAR OF THE MANUAL TRAINING SCHOOL.

IT will be more convenient for those who hope to be guided somewhat by our experience, if I give in detail the work and appliances of the several classes or grades separately. I shall therefore devote this chapter to the work of the first year in the school; and I shall describe not so exactly my school (which has, I am painfully aware, many shortcomings), as an *ideal* school, which, better than any *real*, shall embody the essential features I wish to present.

The boys on admission average fifteen years old, — none are less than fourteen. All have sustained fairly an examination in elementary arithmetic (written and oral), geography, composition (including spelling, penmanship and the use of good English), and reading.

I shall assume that there are seventy-two boys in the class, arranged in three equal divisions.<sup>1</sup>

The DAILY PROGRAM<sup>2</sup> is as follows: —

DIVISION.	9-10.	10-11.	11-12.	12-1.	1-2.	2-3.	3-4.
I.	Wood-Shop.		Mathematics.	Science.	Recess.	Latin or English.	Drawing.
II.	Mathematics.	Latin or English.	Wood-Shop.			Drawing.	Science.
III.	Latin or English.	Mathematics.	Science.	Drawing.		Wood-Shop.	

<sup>1</sup> Three divisions, or a multiple of three divisions, is the most convenient number for a class, as all the shop appliances are thus kept in continuous use.

<sup>2</sup> For a program which gives an hour-and-a-half instead of two hours daily to shop, see Appendix for the program of the Toledo school.

It will be observed that each division has three recitations for which three full hours are allowed. If the actual recitation time is but forty minutes per subject, the boys have twenty minutes *after* reciting for studying under the eye of the teacher. About two hours of solid study per day should be done at home.

It may be assumed that the drawing teacher is also the mathematical teacher; and that the science teacher is also the language teacher. One teacher has entire charge of the shop-work. The class therefore requires three teachers.

The appliances are readily described:—

1. An assembly room (which may also be used as a recitation-room) with seventy-two single desks and chairs.

2. A drawing room (fitted also as a recitation-room), with twenty-four drawing stands, and a case for seventy-two drawing boards.

3. A shop about forty feet square, furnished as described later on.

4. A store-room in which lumber is kept and where stock may be reduced to "blank" sizes by a band-saw. Cupboards in which finished exercises may be put away for exhibition may stand at any convenient places.

5. I should not omit, in addition to the usual wardrobe, a spacious and well-furnished lavatory where twenty-four boys may wash at once.

All the rooms are above ground, well lighted with windows running to the ceiling, and well ventilated. In cold weather the ventilation should be effected without resorting to the windows.

Returning now to the program, we find a great deal that is familiar to every teacher.

The mathematics of the year is higher arithmetic and algebra, about twenty-four weeks of the former and fifteen of the latter, with five recitations per week.

The science is Huxley's Primer, physical geography, and botany, with individual collections and herbariums, and class excursions; or the equivalent of the above.

The language study is English lessons once a week for all,

and a choice between Latin on the one hand and more English lessons and history on the other, four times per week.

Under the head of drawing, penmanship comes two half-hours per week.

#### DRAWING.

I must say considerable about drawing, as very few teachers have had suitable opportunity for the study of projections, and for instrumental work.

We begin with free-hand projection work on the blackboard. Plane-faced blocks are used as models, and the pupils are taught to make three projections and to arrange them consistently as in Fig. 5, which gives three "views" of a block which is

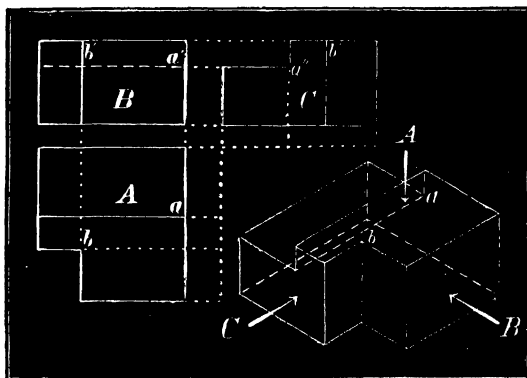

FIG. 4. ORTHOGRAPHIC AND ISOMETRIC PROJECTIONS.

shown in "isometric" projection in the lower corner. The three views are those indicated by the arrows A, B, and C. A may be called the "top" view; B the "front" view; and C the "side" view, looking *towards* the right. The observer is supposed to be so far from the object that there appears no convergence between parallel lines. In every projection, invisible lines (corners, edges, etc.) are drawn broken (with short dashes).<sup>1</sup>

<sup>1</sup> The principles involved in orthographic drawing may thus be concisely stated:—

1. All lines which are perpendicular to the picture plane are projected in *points*.
2. The projections of lines parallel to the picture plane are parallel and equal to the lines themselves.

Another example of a working drawing is shown in Fig. 5. Construction lines are made of fine dots.

This figure gives a top view, an end view, and a side view of the mortise piece, the last as seen from the *right*. In *isometric* projection is shown the tenon-piece and wedge which are to fill the mortise. The  $45^\circ$  line shown in the figure gives a convenient means of finding the side view from the other views without the use of measuring tools, using only T-square and triangle.

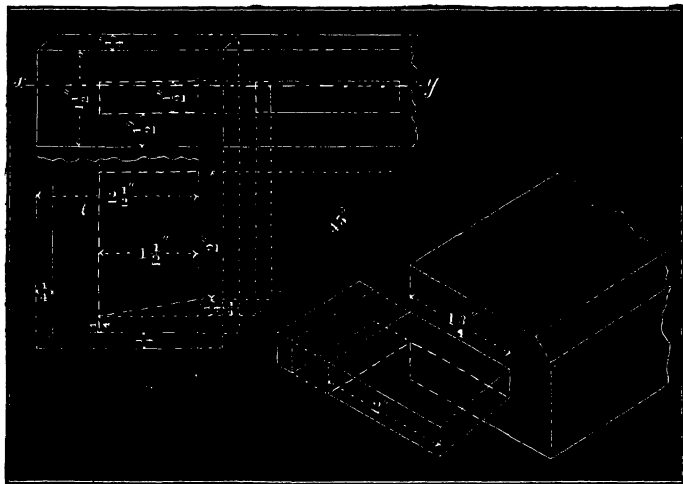

FIG. 5. A BEVELED CORNER-PIECE OF A FRAME, WITH A BLIND MORTISE FOR A HALF-DOVETAILED TENON AND A WEDGE.

While an isometric drawing of the tenon is very satisfactory, an isometric of the mortise would show very poorly in consequence of its peculiar shape and position. Both teacher and pupil should thoroughly understand these drawings. The line  $x-----y$  will be explained below. If there is

3. The projections of parallel lines which are oblique to the picture plane are parallel.

4. The projections of lines oblique to the picture plane are shorter than the lines themselves, i.e., the lines are "foreshortened" in the drawing.

5. There is a separate picture plane for every "view," or projection. In the case of a "top" or "bottom" view, the picture plane is horizontal. For a "front" or "back" view, the plane is vertical. For a "side" view, the picture plane is vertical and perpendicular to the front vertical plane.

the least obscurity in this drawing, let the reader take it to a first-class workman and have him make an exact model of the piece, *full or double size*.

As a third example (and the ingenious teacher will then be able to carry them on indefinitely), I give an exercise which recently I gave to test the proficiency of a class. I took an empty chalk-box without a cover, and made a small hole in one of the sides; then placing the box on the table, I passed a slender, straight stick over the end, down through this hole to the

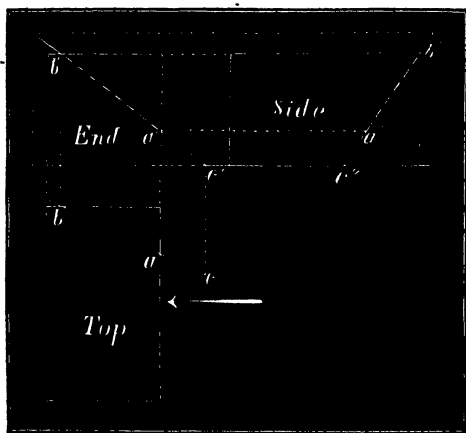

FIG. 6. PROJECTION DRAWINGS OF A CHALK BOX AND ROD.

table outside the box, and let it rest touching the table. The pupils were to draw a *top* view, a *side* view, and an *end* view of the box, with consistent views of the stick. The drawings as required are shown in Fig. 6. The pupils were to estimate dimensions and to use any scale they liked. The chief things were fullness and consistency.

If this is to any extent unfamiliar, the reader should construct a model and examine it in connection with the views in Fig. 6. I assume only a line thickness for the sides of the box, and for the stick. In the side view that part of the stick between *a* and *b* is invisible.

A little later the pupil will be able to draw an oblique view which will give the true length of the rod.

The intimate connection of all this work with the shop work is obvious. The drawing and shop teachers must work in harmony, and considerable drawing must be done during shop hours, as will be shown later.

In the drawing class, pencil work supplements black-board work. The latter is of necessity free-hand (tho a string is



an excellent instrument in transferring dimensions from one projection to another); the paper work *may* be free-hand, tho it is better to have a part of it done with instruments, so as to secure habits of precision, and fix high ideals in the memory. A finely executed drawing, *when fully understood*, has many of the elements of beauty, and makes a lasting impression upon the student.

It is hardly necessary to add that a class should have repeated and alternating exercises in making drawings from objects, and objects from drawings. But let the teacher *make haste slowly*, and *give no exercise to the class which he has not first done himself*. Clay may be used in reading drawings, i.e., in translating drawings into concrete forms. An object drawn this week may be reproduced next from the drawings alone.

Simple objects are generally sufficiently defined by two projections, called "plan" and "elevation." A "section" is a projection of a part of an object supposed to be cut in two by a plane. One part is supposed to be removed, and the observer is supposed to be looking perpendicularly to the cutting plane, and towards the newly-cut face. It is customary to shade sectional faces by oblique parallel lines, and, if the section shows two or more separate pieces of material, to give the shade lines on different pieces different directions. For example, suppose that for the sake of clearness, I wish to show the pupil how the three pieces shown in Fig. 5 are put together. I make an elevation of the finished joint and then draw across it

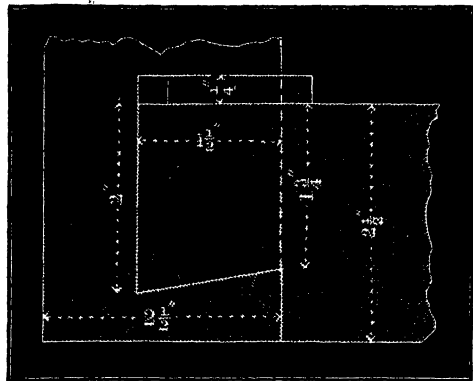

FIG. 7. SHOWING SECTION OF THE BLIND HALF-DOVE-TAIL JOINT, REPRESENTED IN FIG. 5, ON P. 19.

the trace of my intersecting plane. The plane, represented by the broken and dotted line *x y*, in Fig. 5, cuts the upper portion of the pieces off, splitting the tenon and wedge in two. The

lower portion of the joint is then shown in plan, or top-view, in Fig. 7. The tenon and wedge are seen in position, the latter not driven quite "home."<sup>1</sup>

As soon as the pupils are familiar with making and reading drawings, they should be put to instrumental work; and here, as in all other instances throughout the school, we apply a simple principle: *instruction* before *construction*. The use of *instruments* is made the direct object of instruction and study. Drawing boards should be of well-seasoned white pine, about 20" × 30". Stretch Whatman's hot pressed paper the full size of the board.<sup>2</sup>

The essential drawing instruments (which should be of German silver, of fair quality) are a 30" T-square; a 45° triangle; a 30°-60° triangle; a pair of dividers; a pair of compasses with pen, pencil, and needle point; a drawing pen; a bow pen; a six-inch box-wood or ivory rule; a metallic or horn protractor; a set of thumb-tacks (for fastening a cover over the drawing paper); and a bottle of prepared India ink.<sup>3</sup> The cost of these instruments with the drawing board is from \$6 to \$10. A cheaper set is hardly worth buying. No good work can be expected from poor instruments, and the pupil should not be at liberty to charge poor work upon his tools.

The first two sheets of instrumental drawing should be devoted to exercises involving only the use of the instruments. Every pupil must learn to draw smooth, uniform lines, light and heavy, straight and curved, with long and short radii, curves and tangents, reverse curves, etc. There should be abundant practice at line-shading, equidistant, uniform lines, and at unequal distances; at lines beginning sharply on one line and ending sharply on another, either straight or curved.

<sup>1</sup> In my simple definition of a section, I do not exclude a drawing which shows several sections made by different planes, as on more complicated drawings.

<sup>2</sup> Soak thoroughly the entire sheet (except a half-inch border all around) in clean water, and then, applying good mucilage to the border, paste it down as smoothly as possible, and let it dry.

<sup>3</sup> This ink-bottle should in every case be set inclined in a block of wood fixed in the front of the student's private drawer (in the drawing stand), which should stand partially open while the student is at work. It is a good plan to have a "stop" on the drawer so that it cannot be drawn wholly out. Later in the course pupils should be shown how to prepare India ink from the stick.

Pupils should learn to draw concentric circles without boring a big hole at the center.

In short, the pupils should learn to draw neatly and accurately whatever lines they attempt, and to keep fingers and instruments clean. When this is achieved, they are ready to draw from objects.

The first objects drawn should be blocks and joints, similar to those shown in Figs. 4-7, which should be carefully measured and drawn to scale, with great care as to both quality and quantity. The next object should be more difficult, yet not too hard, nor involving too many hours of work.

Two short exercises are better than one long one. Select at first such objects as large bolts, nuts, elbows and joints of iron pipes, having the *real* objects at hand. Then later the tail-stock or the head-stock of a speed-lathe; an iron center-rest; a vise; a jack-plane; a large stop valve; a monkey-wrench (large size); etc. It may be well to give one-half of a division one object, and the other half another.

The first drawings of an object should be free-hand projections executed on a scale large enough to show clearly every measurable detail of form. When the free-hand drawing has been made, the pupil should measure the object with rule and calipers, and record these actual dimensions on the corresponding parts of the free-hand drawing. This free-hand drawing, thus "figured," should serve as a "sketch" from which the finished instrumental drawing of the object is to be made.

To make the drawing of the object complete, not only projections and sections of it as a whole are to be made, but projections of the parts in detail, taken one by one.

The conventions of shadow-lining may be readily taught in connection with such work.

Meanwhile the class should be practised in single projection, with pencil shading, of simple tools, pieces of furniture, and miscellaneous objects, from either objects or from other drawings differently made. One drawing a week, done "out of hours," is a moderate request.

Finally, throughout the year, instruction should be given in **LETTERING**, and a large allowance of time should be given to

the practice of letter-making, of a great variety of styles, both free-hand and with instruments, with pencil and with ink.

While the above explicit account of our work in drawing during the first year may be readily comprehended by a teacher already familiar with instrumental work, it is quite impossible for one wholly unfamiliar with the use of drawing instruments to appreciate either my directions or the work itself. Observe that we do not indulge in picture-making, nor in ambitious and fruitless attempts to appreciate fine art, not to do artistic work, as may older and special students.

The ideas we teach are fundamental, and the practice we require is the stepping-stone to the more difficult and more finished work of the subsequent years.

Here let me say a word upon the question I have heard earnestly discussed by drawing teachers: Should pupils be allowed to use rulers to assist them in drawing lines which should be straight? In the first place, I remark that the question is *relatively* of small importance, and it has been allowed to cover out of sight another question of ten times more consequence, viz.: What does the line *mean*? The line has, or should have, a great deal of meaning, and it should be adequate to express that meaning. When a line is fully understood, it becomes transfigured; it is no longer a mere line,—it is the outline of an object, the intersection of two surfaces, the expression of an idea or of a fact. *This* is the important thing, which no fussing about hard and soft pencils, single-stroke or built-up lines, straight edges and curved rulers should be permitted to hide.

Then, secondly, if the eye and the mind are to be cultivated, there should be continual reference to drawings which are nearly perfect: where straight lines are straight; where circular arcs are circular; where parallel lines are equidistant; and where three or more lines, which are supposed to meet at a point, actually do so meet. For the sake of a power of execution by both methods, free-hand and mechanical drawing should alternate. It is, however, foolish and illogical to dwell upon certain considerations which only accomplished artists can

appreciate. They are a thousand times above the heads of one's pupils, and far removed from the plain work they should do.

#### THE WORK IN WOOD.

I now turn to the still more unfamiliar details of our shop-work. I assume that what I have said about the drawing has been read and understood.

As before stated the shop should be a well-lighted room about forty feet square. It should contain twenty-four single (or twelve double) benches, with twenty-four "coach-maker's" vises, twenty-four wood lathes and twenty-four sets of common tools. The engraving gives a view of our shop with the boys at their places, taken from a photograph.

The "common tools" are arranged on racks or screens as seen in the engraving. Connected with the benches there are seventy-two tool-drawers in which the "individual" tools and the students' caps, aprons, blouses, soap and towels, etc., are locked. The keys for each division, twenty-four in number, are hung on a "key-board" which, when the division is not in the shop, is kept in the instructor's closet.

Besides the above, the teacher should have a lathe, a suitable kit of tools, and a bench so placed as to be in full and convenient view of his division when arranged in double row around him to witness a practical exercise or hear an illustrated lecture.

Across the ceiling run the main shaft and the counter-shafts of the lathes, from which hang the belts and belt-shifters. Two grindstones are needed, and these should be kept in motion during shop hours. By a clutch or tightener, the teacher should be able to stop and start his main shaft at will.

The first part of the year is given to bench work, or the ELEMENTS OF JOINERY.

During his two hours' stay in the shop, each boy has the exclusive control of a work bench with a reasonably full set of tools. The bench is equipped with an iron vise with three-and-one-half-inch jaws. This vise may be set on the side of the bench, or on the end away from the space used in planing.

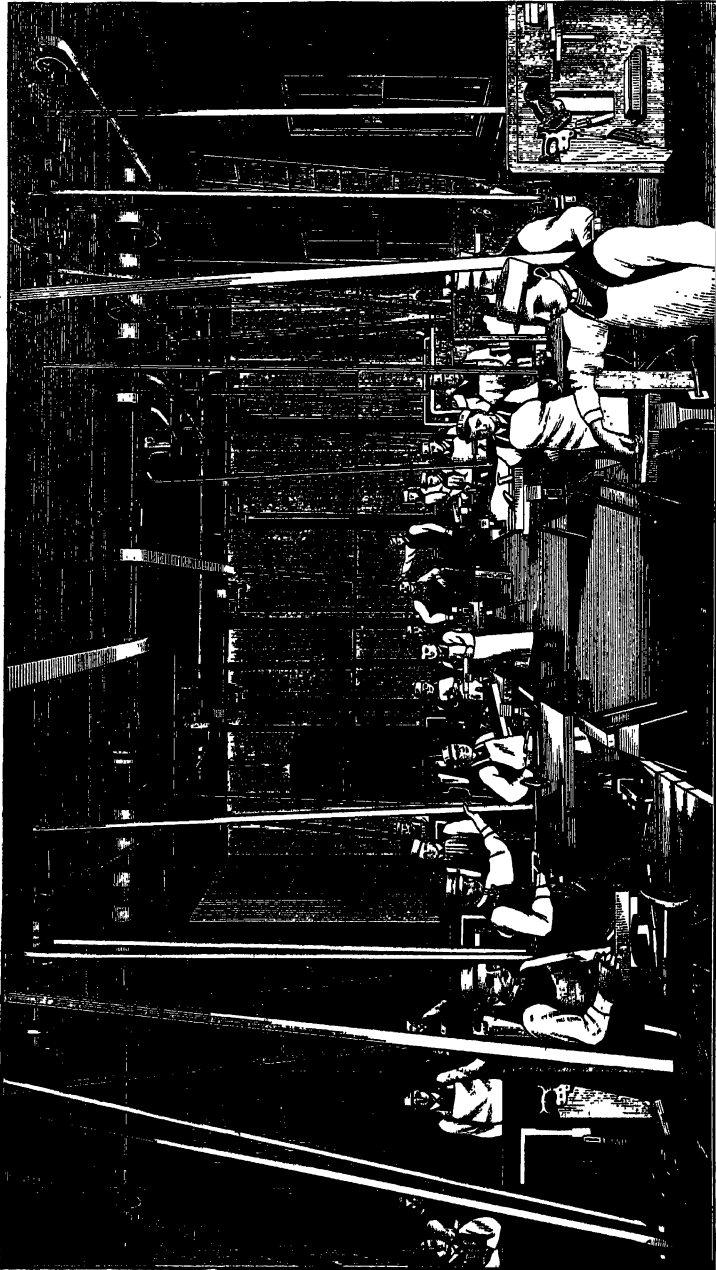

FIG. 8. THE WOOD-WORKING SHOP.

The benches are double, nine feet long and three feet wide. As the student faces the center of his bench, the lathe is on his right, the vise and drawers on his left. The rack has a set of "common" tools on each side. There is a light trestle to every double bench. The blackboard and the teacher's office are out of sight on the left. Twenty-four boys fill this shop. The ceiling is inconveniently high.

The benches themselves should be very strongly made and vary in height from thirty to thirty-four inches.

I suggest the following as a *minimum* kit of "common" tools to be kept on the rack of the bench:<sup>1</sup>—

## KIT OF COMMON TOOLS.

One 20" rip-saw	. . . . .	Costing \$1.60
" back-saw	. . . . .	" 1.00
" claw-hammer	. . . . .	" .40
" mallet	. . . . .	" .25
" small steel square	. . . . .	" .80
" six inch try square	. . . . .	" .25
" marking gauge	. . . . .	" .25
" T-bevel gauge	. . . . .	" .25
" pair compasses	. . . . .	" .20
" oil stone	. . . . .	" .50
" oil-can	. . . . .	" .15
" screw-driver	. . . . .	" .20
" bench brush	. . . . .	" .80
Total	. . . . .	<u>\$6.15</u>

All the above tools should be supplied at the start, and are to be used in common by the three boys who in succession occupy the bench during the day. The remaining tools are either in the individual sets given the boys, or in the special, occasional kit in the teacher's closet.

An "individual" set, which is to be used by only one boy, to be kept in his private lock-drawer when he is not in the shop, and is to be issued as needed, includes:—

## KIT OF INDIVIDUAL TOOLS.

One 20" panel cross-cut saw	. . . . .	Costing \$.80
" jack plane	. . . . .	" .60
" smoothing plane	. . . . .	" .50
Four chisels: $\frac{1}{4}$ ", $\frac{1}{2}$ ", $\frac{3}{4}$ ", 1"	. . . . .	" .90
Three gouges: $\frac{1}{4}$ ", $\frac{1}{2}$ ", 1"	. . . . .	" .70

<sup>1</sup> My estimates of cost in these several lists of tools are based on the prices given me by the Simmons Hardware Company of St. Louis, which has furnished us with the greater part of our tools.

Two turning gouges: $\frac{1}{4}$ " , $\frac{7}{8}$ "	. . . . .	Costing	\$5.55
" turning chisels: $\frac{3}{8}$ " , $\frac{7}{8}$ "	. . . . .	"	.45
One parting tool . . . . .		"	.40
" round-nose tool . . . . .		"	.40
" pair 5" calipers . . . . .		"	.25
" two-foot rule . . . . .		"	.15
" oil-stone slip . . . . .		"	.15
			<hr/>
Total . . . . .			\$5.85

The speed lathe has about 8" swing and is furnished with: a face-plate, a removable screw-center, a spur-center, and a nine-inch rest.

#### OCCASIONAL AND SPECIAL TOOLS.

These are kept under the personal charge of the instructor, to be given out for special work. They are:—

One large steel square . . . . .	Costing	\$1.25
" 24" cross-cut saw . . . . .	"	1.35
" 24" rip-saw . . . . .	"	1.60
Two jointer-planes, 22" long . . . . .	"	2.20
" fore-planes, 18" long . . . . .	"	1.60
" bit-braces . . . . .	"	2.50
" sets bits, counter-sinks and screw driver . . . . .	"	8.20
One hatchet . . . . .	"	.60
Two nail sets . . . . .	"	.30
Two $\frac{1}{2}$ " screw taps and dies for wood . . . . .	"	1.60
One draw-shave . . . . .	"	.90
One spoke-shave . . . . .	"	.40
Two monkey wrenches . . . . .	"	1.00
One compass saw . . . . .	"	.35
" full set of 12 wood-carving tools with handles . . . . .	"	4 75
glue-pot complete with lamp or steam connection . . . . .	"	1 50
		<hr/>
Total . . . . .		\$30.10

A small supply of shellac, staining material, and varnish should always be on hand, as well as sand paper and machinist's waste. Other tools and appliances may be added as their use is seen to be necessary.

The cost of the entire outfit of the shop (excluding power) for 72 boys may now be given approximately as follows:—



Twenty-five benches @ \$15 . . . . .	\$375.00
Twenty-five sets "common" tools @ \$6.15 . . . . .	153.75
Seventy-three sets "Individual" tools @ \$5.85 . . . . .	427.05
Set of Special and occasional tools . . . . .	30.10
Twenty-five coach-maker's vises @ \$5.00 . . . . .	125.00
Twenty-four speed lathes @ \$25.00 . . . . .	600.00
Shafting, pulleys, belts, etc. . . . .	150.00
Grindstones, with attachments . . . . .	40.00
Wash trough, dishes, plumbing, etc., say . . . . .	80.00
Total . . . . .	<u>\$1,980.90</u>

If turning and all power attachments are omitted and only joinery is taught, the cost is about \$1,000.

If twenty-four sets of special wood-carving tools are added, the cost will be increased about \$114.

These tools will if well looked after last many years. It will have a wholesome effect if the rule, requiring tools carelessly broken or lost to be replaced by the responsible parties, is strictly and impartially enforced.

It thus appears that the special shop outfit costs from \$23 to \$29 per boy.

The cost of the engine is omitted, as it is counted into the expense of the Machine Shop.

The tools should all be of good quality and the best patterns.

The *Lumber Room* is an important adjunct to the wood-working shop. The lumber should be brought out in convenient shapes ( $\frac{1}{2}$ -inch boards and 2-inch planks, 2nd or 3rd quality; square strips of hard wood, two or three inches square; etc.) and piled so as to be readily handled. For the purpose of getting out the stock, a band-saw and table is quite necessary. I prefer the band-saw to the circular for three reasons:— It is safer; it is less noisy; it cuts faster. I insert a cut (Fig. 9) of the band-saw we use, the price of which is made \$100 by the makers, Hall & Brown, St. Louis.

No wood-planing machine is necessary. Either the lumber comes planed or the pupils should plane their own.

It wastes a great deal of time to have the pupils of a class get out their own stock; it is far better to have the janitor or the teacher get it all out beforehand.

The lumber should be bought in time to allow it to thoroughly season before it is used. Some fitting may be done with green lumber for the purpose of showing how much it shrinks and the necessity of providing for the shrinkage.

#### THE METHOD OF SHOP INSTRUCTION.

While I am desirous of making a full statement of our method of shop-work, it is evident that I cannot furnish that real knowledge which the teacher must have. I can however greatly assist one who has had some experience with tools and who has attempted or is to attempt systematic class-work.

From the first this is to be borne in mind; that the object of shop-and-tool instruction is chiefly mental discipline. The tools are to be intelligently used, and the methods of execution adopted are to be chosen intelligently. Least of all do we care for the concrete product except as it bears witness to progress.

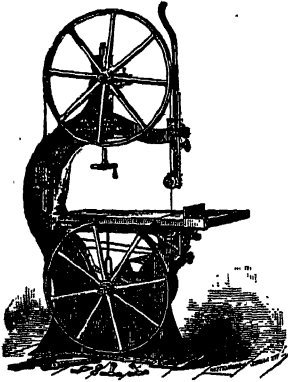

FIG. 9. BAND-SAW.

Neither good tools nor established methods are what they are from mere chance or caprice. They are the result of *growth* and *logical* development, and that both the tool and the method may be fully understood, both are to be fully explained and taught.

Cases are very rare wherein pupils may be left to find out the methods or the right tools for themselves. In general, *they should be taught the right way from the start*, the prevalent incorrect methods may be pointed out as illustrations of "How not to do it." Clumsy, unhandy, untidy, unintelligent habits should not be allowed.

Above all, the pupil must do his work *himself*; no other evidence of his ability to do it should be accepted. Occasionally, the teacher may do a stroke of work on a boy's piece, as he would write a word for him in his copy-book, or draw a line on his projection for the sake of showing him "just how," at a time when his attention and interest are at a maximum; but the

teacher should be cautious of giving aid. He should never give the boy any reason to think that the piece is not his own, nor to suspect his own honesty in claiming it as such.

In general, the teacher should execute all typical exercises anew for each division, and in its presence, employing just the method and order he wishes his pupils to follow. His style and his piece should both be of a high order of excellence.

The first exercises are with the cross-cut saw, try-square, and planes. In learning to use the saw, soft lumber — second or third quality of white pine — about two inches square should be used. In marking for the saw, draw sharp, clean lines with knife — don't use scratch awls — on two or three faces and then cut *just to* the lines. In sawing carry the hand lightly and don't bend the saw. Two or three cuts may be made to the inch.

The importance of the saw-cut, may be taught by using a piece of  $\frac{7}{8}$ " stuff say 6" by 20," with at least one straight edge along which to apply the try-square.

Draw lines across, every half-inch, stopping them at a gauge-line one inch from the straight edge. Then cut carefully down the cross-lines to the gauge-line in such a way that when alternate pieces are knocked out the spaces will all be the same, and *as wide as the parts which remain.*<sup>1</sup> The accuracy of all this may be tested by cutting the whole piece in two, and interlocking the projections. The test is severe even for a good workman.

Similar exercises may be given in sawing obliquely to the grain with the saw which is *best suited to the work*, laying out the work with either the try-square or the T-bevel gauge. See Fig. 10 for the position<sup>2</sup> while using the "rip-saw."

The general and special features of the jack and the smoothing planes require full exposition and illustration.

Methods of grinding, oil-stoning (see Fig. 11), and setting planes should be given with great precision, and they should be well illustrated by drawings.<sup>3</sup>

---

<sup>1</sup> One of the series of exercises given below is based on this principle.

<sup>2</sup> For several of these exquisitely-drawn wood-cuts, I am indebted to the little volume, "How to use Wood-working Tools" published by Ginn & Heath in 1881.

<sup>3</sup> There are various kinds of planes which the teacher may use in his lecture on planes. The Bailey patent adjustable plane is a great favorite with some, while others prefer the old-fashioned wooden plane.

When lumber is rough and more or less irregular, the plane is an indispensable tool, and the workman must know his tools. The operation of reducing a rough piece approximately

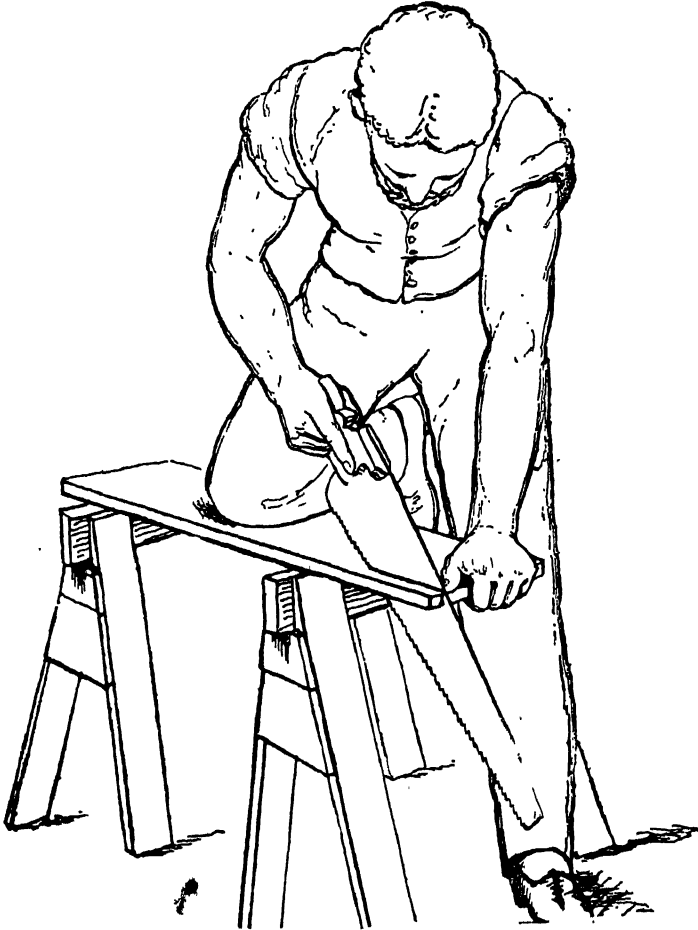

FIG. 10. USING THE RIP-SAW ON A BOARD.

2"  $\times$  2" and a foot long to a smooth 1 $\frac{3}{4}$ " square, is not an easy one, and most students fail at first. Some succeed only after many failures, and some never succeed. The method of holding the plane for the first part of a stroke is shown in Fig. 12. The left hand keeps the toe of the plane down.

When a boy has spoilt his piece, i.e. taken off so much stock that a piece  $1\frac{3}{4}$ " square is no longer possible, it is a good plan to change the dimension to  $1\frac{1}{2}$ " and let him try again. Similarly, reduce to  $1\frac{1}{4}$ ", to 1", and even less after further failures. I have seen boys, who, like the monkey judge in the fable, inevita-

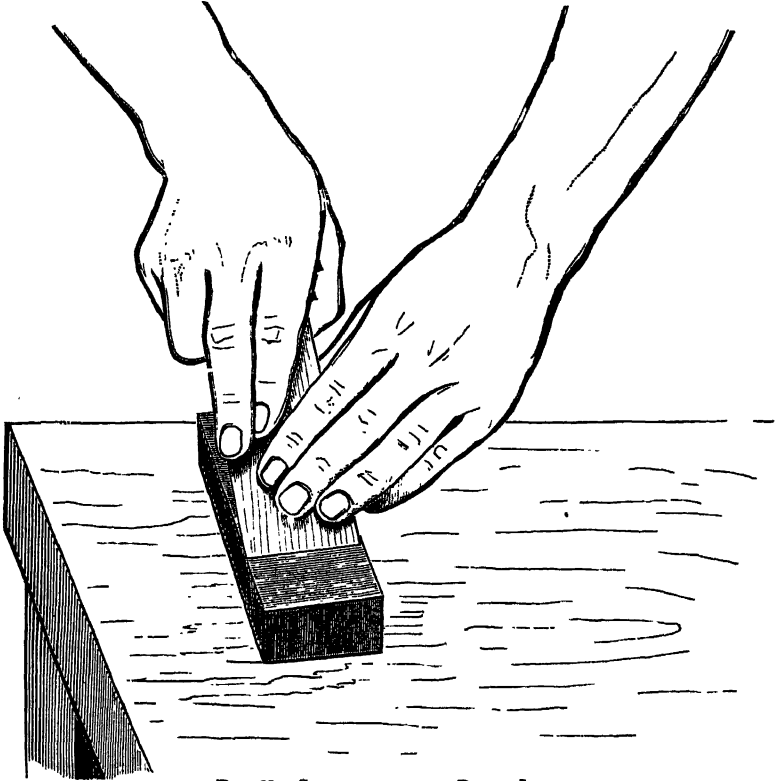

FIG. 11. SHARPENING THE PLANE-IRON.

bly "took off too much from the other end" till there was nothing left.

The skillful teacher proceeds with system and great caution. There should be no hap-hazard work and the class is to be kept together. He outlines the steps for squaring up a piece substantially as follows:—

1. Select the cleanest (freest from knots, etc.) and most uniform face and plane it smooth and true. Test the accuracy of

the surface by the edge of the try-square. Mark this face thus : X, with pencil.

2. Select the most suitable adjacent face and plane it *square*

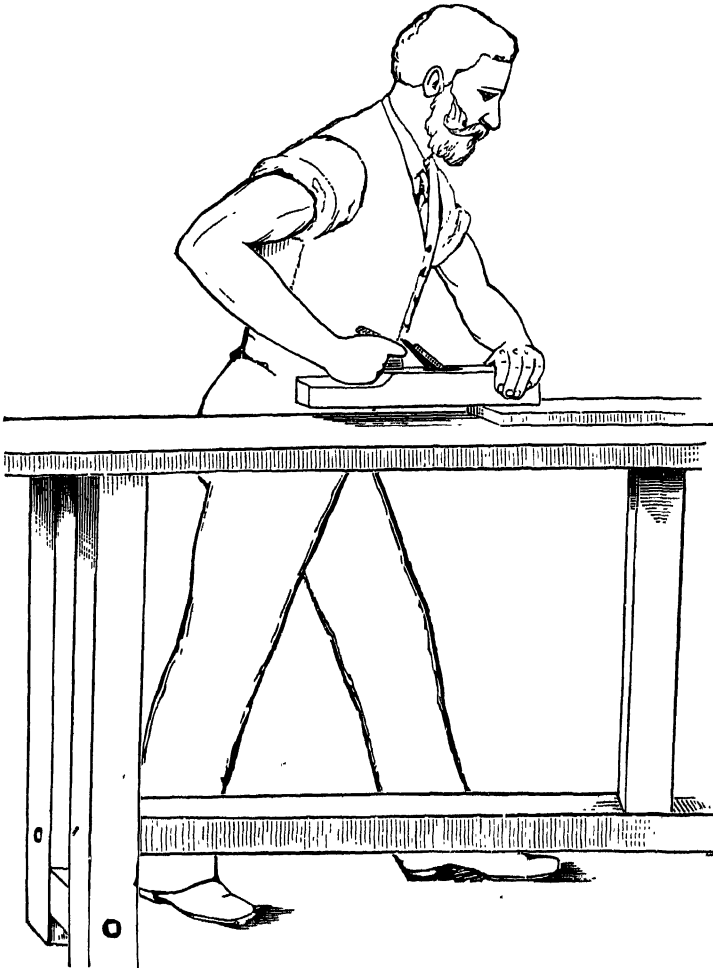

FIG. 12. THE TOE IS PRESSED DOWN WITH THE LEFT HAND.

*with the first.* Use the smoothing plane, set fine, and apply the try-square frequently.

3. With the marking gauge (and the pupils should be shown

how to set and how to use this tool on a separate piece) lay off  $1\frac{1}{4}$ " (or less, as the case may be) on each finished face from the finished edge.

4. In succession, dress the two remaining faces down to the gauge lines, testing with the square as often as is necessary. Do *not* scratch a third gauge line for the last face, nor square from No. 3. The reason for the caution in the last remark is that if face No. 4 is worked from No. 3, it is likely to have an "*accumulated*" error.

It should be taken for granted that no real work is exact, i.e. we cannot realize the ideal dimensions. What we call "accurate" is only a close approximation. While we should *aim* at absolute accuracy, we must never assume that we have reached it; accordingly, as No. 3 is based upon No. 1 or No. 2, it is supposably less accurate than either, and hence ought not to serve as a base for No. 4. The teacher should fully illustrate this *accumulation of error*, which like a story or a snow-ball grows as it proceeds.

For example, let each student be told to cut off twelve pieces of wood of a definite length (for future exercises), using the first piece as the measure of the second, the second as the measure of the third, and so on to the last. Then let him compare the last with the first, and standing the pieces in order on his bench let him see whether they have been growing longer or shorter as he proceeded.

I am aware that to teachers unused to tool work, and to the thoughtful logic of mechanical methods, this may appear like much ado about trifles. If such there be, let me assure them that if they will take a single course of lessons in a "Manual Institute" the appearance of these matters will wholly change. And again, let me say that when one speaks of trifles, the average healthy mind, intent upon one's duties as a home-maker and a good citizen, looks with wonder and pity and perhaps with contempt upon Browning's "Grammarians" whose life work appears to be a lofty devotion to trifles.<sup>1</sup>

---

<sup>1</sup>"He settled Hoti's business — let it be! —  
Properly based Oun —  
Gave us the doctrine of the enclitic De,  
Dead from the waist down."

The ability to saw to a line and to square up a piece of required dimensions prepares the class to undertake mortise-and-tenon joints. Great emphasis must be placed upon correct methods of laying out the work. It is an excellent plan to let making the drawing and laying out the lines which are to be worked to on the squared piece constitute an entire exercise. The gauge lines should not be extended unnecessarily nor should any coarse lines be used. With the try-square use either a sharp pencil or a pocket-knife. Do not allow a slovenly method of laying out, on the ground that subsequently the lines will be planed or sand-papered off, and that when the finished joint is planed down, the surfaces *must* be flush. No such dishonest, unscientific tricks should be tolerated in a manual training school.

In making tenons use the "rip" and the "back" saws, sawing accurately to the line and *not removing the saw marks*. In "open" mortise-and-tenon joints, like Figs. 17 and 18, use the saws for all but the base of the mortise where the chisel is necessary. Preliminary to mortising comes the theory, care and use of the chisel, with and without the mallet.

Each boy now needs a "bench-hook," which is preferably made of hard wood and put together with screws. It is made of three pieces of wood and four screws. This "hook" is used as a shield to the bench in all exercises where the tools are likely to strike the support; and where the vise is not needed. It is held as shown in Fig. 13. The screw holes in the cross-pieces should be made with the bit to prevent splitting.

The construction of the hook is seen to cover several important points.

It is hardly necessary to say that special exercises are necessary for showing how narrow and wide chisels may be used in paring, smoothing, and excavating. In mortising, the aim should be square corners and good surfaces even for parts entirely hidden in the closed joint. As bits and augers are used or may be used to advantage in mortising, their use should be taught in preliminary exercises.

A fair proportion of hard woods — ash, maple, beech, chestnut, walnut, and oak — should always be used in these bench



exercises, and a certain number of exercises should be given in working obliquely to the grain.

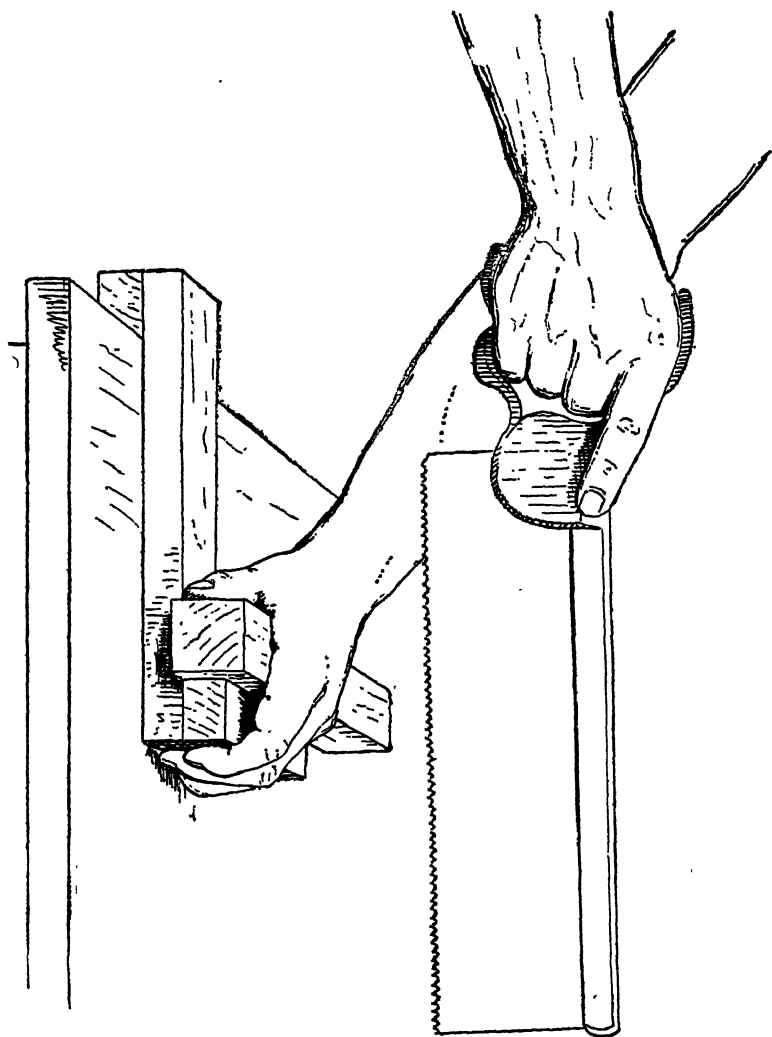

FIG. 13. SHOWING THE USE OF THE BENCH-HOOK.

The operations of gluing should be well taught. Occasionally a joint may be glued, tho as a rule it should be left unfas-

tened so that it may be inspected more thoroughly. In building up composite work, use different colors, or aim at effects by contrast of grain.

Here the jointer-planes come in use for the last touches of a joint.

A fore-plane serves the same purpose, though it differs less from the short smoothing-plane.

#### THE SHOP DRAWINGS.

The teacher should have a generous blackboard in his shop on which to make and sometimes to preserve important drawings. The drawings should always be made with care, and generally they should be of large size. The style of the teacher's work has great influence upon the pupils.

Every boy should have a blank book for his shop drawings, which he should leave in his locked drawer at the close of his work. Into this book should be copied in succession all the working drawings placed by the teacher on the blackboard, or on large sheets of paper and hung before the class.

The drawings should be made with care, of ample size (the tendency of boys is to make them too small), and generally with the use of a straight edge. It is not strictly necessary that they should be made to scale, for the "figured" dimensions should always be given in full. No boy should be allowed to begin his piece, till his drawing has been examined and approved by the teacher.

#### WOODWORKING EXERCISES.

I give below the main features of our exercises. The minor features which are always more numerous cannot be shown. These latter are connected with the theory of the tools, or are preliminary to the regular course. With very young pupils they should be far more numerous than with mature students. An *average* of one *new* exercise in three lessons is enough for boys fifteen years old.

**No. 1.** Use of jack plane and try-square. To "square up" a piece from rough stock.

**No. 2.** (*Fig. 14.*) Use of cross-cut saw. Stock, common pine board 14" long, 4" or 5" wide. Lay out and saw as



*carefully* in their books. See directions for making shop drawings on page 38.

**No. 5.** (*Fig. 17.*) An open mortise-and-tenon joint. The stock may be of any convenient size. Saw to the lines

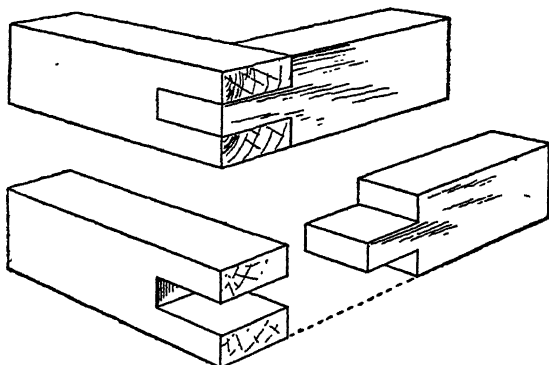

FIG. 17.

if possible. Do not bruise or mar the corners. Do not plane off the finished work to remove evidence of inaccuracy.

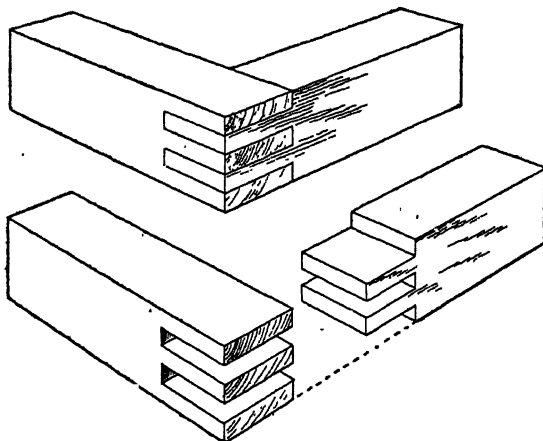

FIG. 18.

**No. 6.** (*Fig. 18.*) An open, double mortise-and-tenon joint. Stock of any convenient size. Observe directions already given. Lay out with care, and saw *just to* the lines.

This is a difficult exercise, and partial failure should not discourage. One may fail in No. 6, who has succeeded well in No. 5.

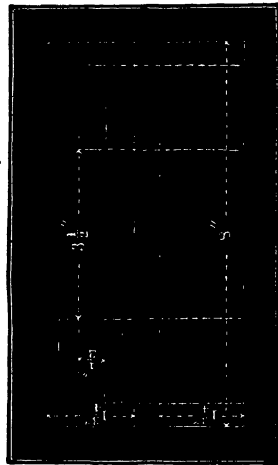
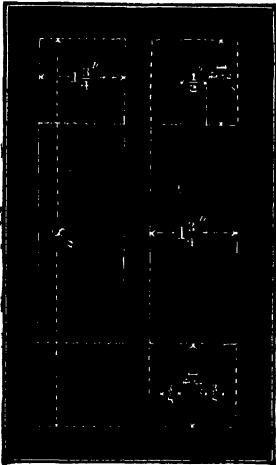
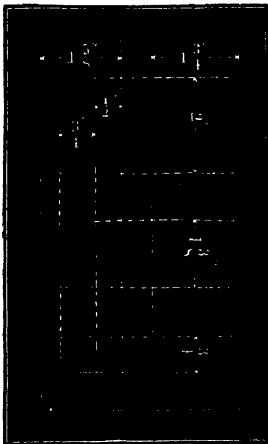
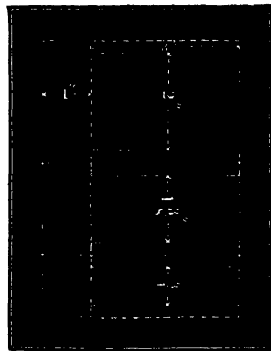

FIG. 19.

**No. 7. (Fig. 19.)** (1) Single mortise-and-tenon closed joint. (2) Double mortise-and-tenon closed joint.



a



b

FIG. 20.

Execute the joints separately. Cut the single tenon wholly with the saws, if possible. Several preliminary exercises may

be necessary to the cutting of the mortises with clean, sharp corners. Do not aim to remove all the gauge marks on the finished work. Do not glue or pin the pieces together.

**No. 8. (Fig. 20.)** (a) Long and short mortises. (b) Sawing out tenons. Execute *a* first. Then cut to the long tenon lines with a rip-saw; then rip into three pieces, and finish the tenons with the back-saw. Do not be discouraged if this require several repetitions. Some of the dimensions have been omitted as variable in different pieces. The chief thing is, that each mortise has its tenon, which runs far through.

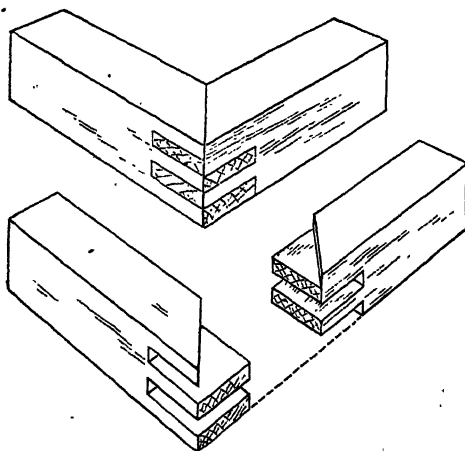

FIG. 21.

**No. 9. (Fig. 21.)** A miter joint with an open, double mortise-and-tenon. Stock,  $1\frac{1}{2}$ " by 2" or 3", and of any convenient length, using both ends, and *not sawing in two* till the tenons are made. The teacher may use either isometric or ordinary orthographic drawings, as may appear best.

**No. 10. (Fig. 22.)** A half-dovetailed joint halved together. Stock of any convenient size. Cut the mortise first, and finish the dovetail of the tenon with a *sharp, wide* chisel, to an exact fit.

**No. 11. (Fig. 23.)** A dovetailed joint with a single tongue. The nature of the exercise is clearly shown in the drawing. Use large stock, so that the dimensions may be dis-

tinctly given. Do not plane off the finished joint. Preserve sharp corners on the mortise.

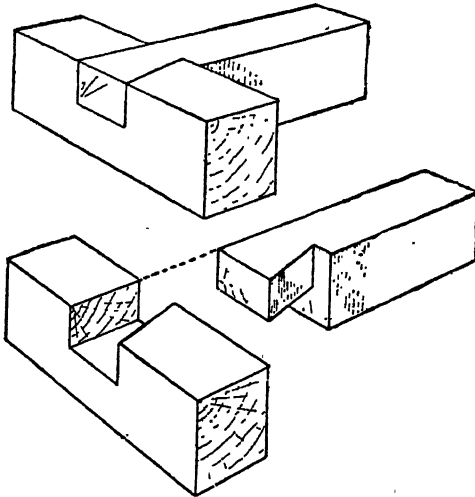

FIG. 22.

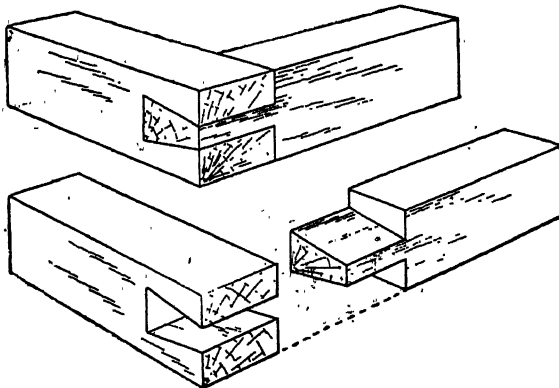

FIG. 23.

**No. 12.** (Fig. 24.) An oblique mortise-and-tenon joint with a pin. The obliquity shown in the drawing is a little less than  $30^\circ$ . Do not attempt to draw the tenon home by the pin; bore the hole through both pieces at once. Leave the pin

projecting, so that it may be drawn out. Extraordinary care should be taken in laying out this exercise.

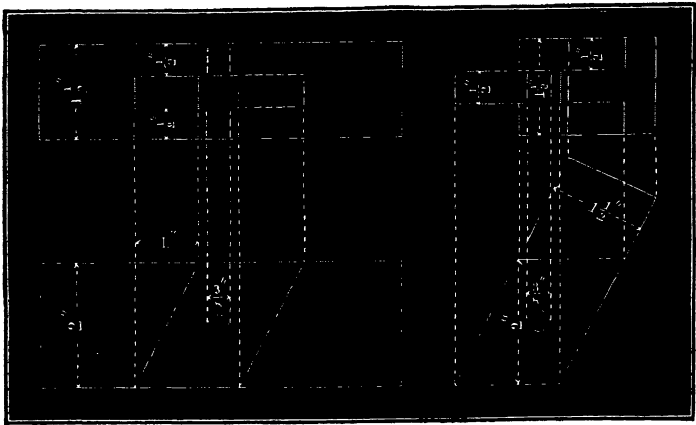

FIG. 24.

**No. 13.** (Fig. 25.) A half-dovetailed mortise-and-tenon joint, with a key. This exercise is sufficiently shown by the drawing.

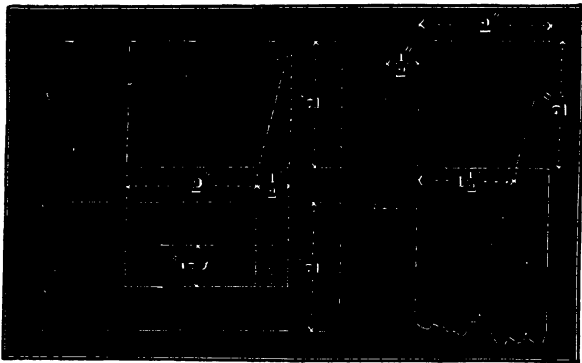

FIG. 25.

**No. 14.** (Fig. 26.) (a) A beveled corner-piece of a frame, with a blind mortise for a half-dovetailed tenon. (b) The dovetailed tenon and key for the mortise. This is a difficult exercise, and some "fitting" is allowable in finishing the tenon and the key. The key should be left long



enough to permit unlocking the joint, tho in a real example it would be cut off, and the joint would be glued as well as locked.

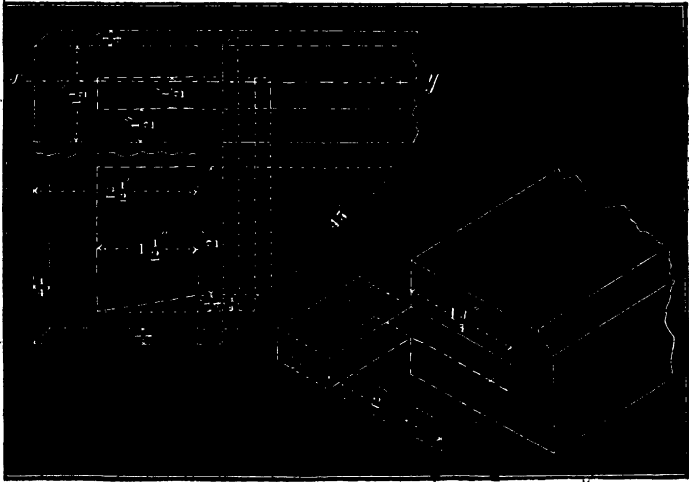

FIG. 26.

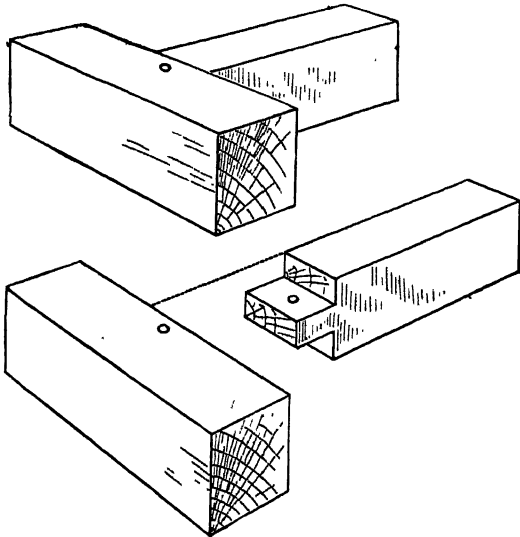

FIG. 27.

**No. 15.** (*Fig. 27.*) A half-blind dowel joint. The dowel pins may be made of hard wood. The bit-holes should be made

in both pieces at once, while the short piece is wholly in the vise. The entire joint should be glued.

**No. 16.** (Fig. 28.) Triangle. **No. 17.** (Fig. 29.) Hexagon. Frames with miter angles of various sizes. The teacher

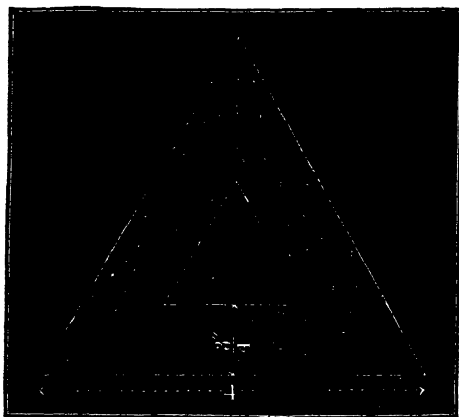

FIG. 28.

should show how to lay out angles of  $30^\circ$  and  $60^\circ$ , using the try-square and compass. Do not use very small stock. Nail

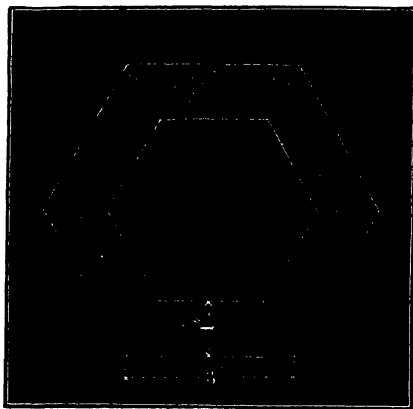

FIG. 29.

or dowel or screw the joints. No. 17 might be made with open mortise-and-tenon joints and pins.

**No. 18. (Fig. 30.)** A rafter joint. Use stock say 3" by 4" and about a foot long. The teacher may add a pin running *down* through both pieces, which would represent a bolt with head and nut.

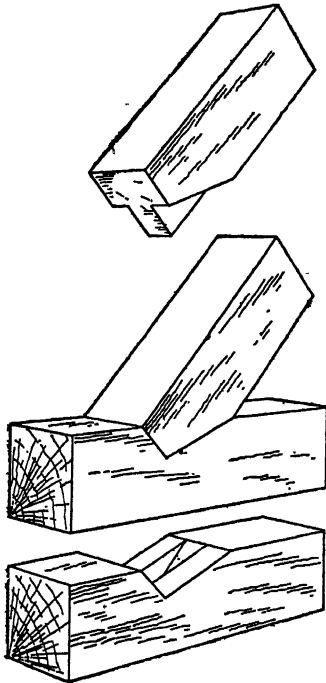

FIG. 30.

**No. 19. (Figs. 31 and 32.)** A dovetail joint with several tongues. This exercise requires precision and a clear head. The work must be laid out very systematically, and be executed with patient care. There can be no objection to gluing the pieces together

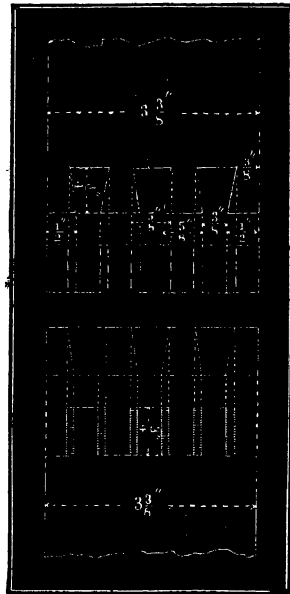

FIG. 31.

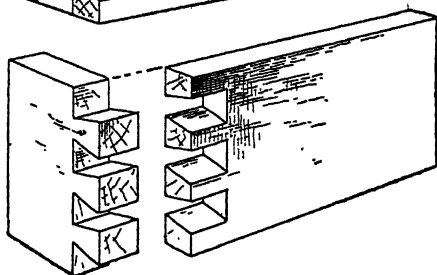
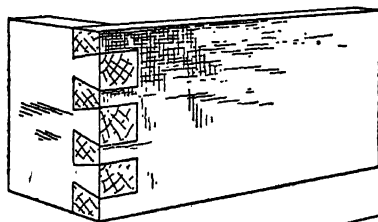

FIG. 32.

when finished. Fig. 32 shows best the nature of the joint, but Fig. 31 gives a drawing to be actually used in laying out such work. The pupil will see that Fig. 31 and Fig. 32 do not represent precisely the same pieces.

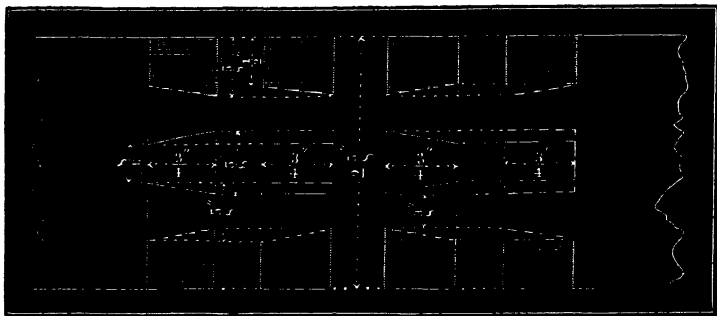

FIG. 33.

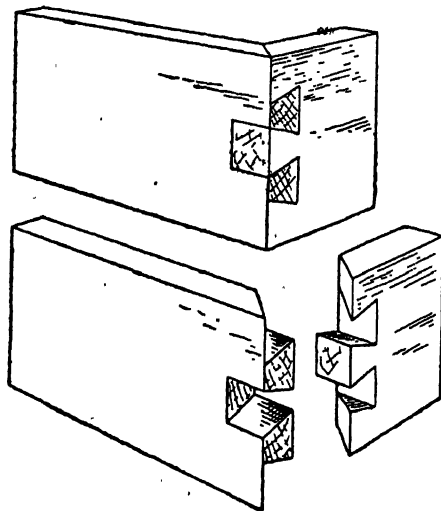

FIG. 34.

**No. 20.** (*Figs. 33 and 34.*) A dovetail joint with a miter. This is equally hard with the last. In place of a third orthographic projection of each piece, I have given a perspective view which at once makes it all clear. The finished joint may be glued.

**No. 21. (Fig. 35.) A false double-dovetailed joint.** This very interesting exercise is difficult from the necessity of sawing very obliquely to the grain for the sides of the mortise. The exact dimensions of the tenon are either given directly, or they may be found on the drawing of the mortise. When well executed and snugly put together, the combination *appears* to represent an impossibility. The double-dovetail appearance forms a puzzle which never fails to interest.

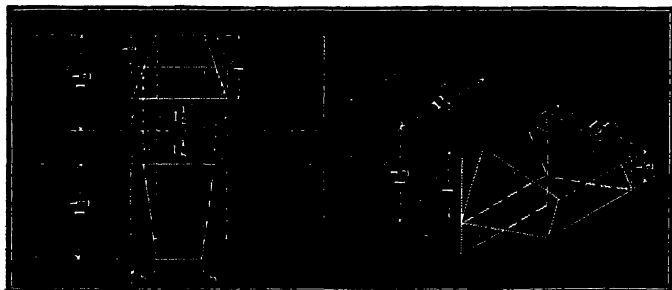

FIG. 35.

**No. 22. A bench project.** This may be a complete box or chest with butts and lock, a table, a model of a roof-truss, a step-ladder, or any other article which will not absorb too much time, and which shall call into play the processes learned. The chest should be made as a box completely closed, and then be sawed open.

The operations of nailing (using different sizes), clinching, withdrawing nails, screwing, pinning, wedging, splicing, keying, etc., should be taught by appropriate exercises.

#### SUGGESTIONS.

It will be found an excellent plan to give all the boys permission occasionally to make what they like, and to carry away the products. In such cases each should submit a scale drawing (figured) of his proposed article, and should furnish the material for the same. The teacher however should endorse no loose plan, nor permit attempts on too complicated work. And here let me caution both teachers and pupils against ambitious

undertakings. There is a very homely, but strikingly appropriate, proverb which may occur to the reader, and which I forbear to quote, but it warns against undertaking more than one can execute. Heed its warning. No "extra" or "project" should be adopted, which has not been looked through in every detail, and for which there is not at command not only all the necessary materials, but all the time that may be needed.

For framing, stock not less than two inches square should be used, and such a design should be used as will show the difference in principle and in construction between struts and ties.

The propriety of using iron ties with washers and nuts may very appropriately be pointed out, tho the class is too young to appreciate such combinations very fully.

One of the first difficulties the teacher of wood-work will encounter is that of unequal capacity in the execution of work. Aside from differences of effort, attention, and application, there will be a marked difference in ability. This difference will be greatest at the start, so that the teacher may comfort himself with the thought that the evil will become less and less as his class progresses.

This is perhaps just the opposite of what the inexperienced teacher would expect. The explanation is, that the natural aptitudes of the pupils do not vary as widely as their antecedent opportunities for tool-work have varied. If a boy has used tools of any kind, be they oars or bats or hoes or axes or knives or trowels or rackets, he will take hold handily, tho it is by no means certain that in a month he will not be inferior to one who at the start was awkwardness itself.<sup>1</sup>

The range of acceptability in the exercises will for the most part meet the difficulty. Suppose the time allowed for an exer-

---

<sup>1</sup> I have learned to thoroughly distrust the new comer who brings a reputation for mechanical skill coupled with dullness at his books. As a rule, such a boy fails to show marked ability of any sort. A boy who came to us with a passion for machinery — who "could not be kept away from engines," the rattle of cogs, and the snapping of belts — never got beyond a sort of morbid, simple curiosity to "see the wheels go round!" He developed no ingenuity, nor the ability to do good accurate work. His book-work was of a very similar character.

cise is two hours. The most rapid and expert need less time, and the very slowest are likely to bring in unfinished pieces; but if reasonable effort has been made, the teacher is bound to accept the result, and rate it at just what it is worth. No boy fit to be in the class can fail to do sixty per cent of the work required, *if he tries*. If he does not try, it is a matter of morals, and should be treated as such, not as a mechanical failure. With honest effort, the slowest boy keeps up as well in the shop, as the slowest boy does in elocution, or penmanship, or in algebra. For very rapid boys who have time for extra work, the teacher should always have in reserve some supplementary exercises based on those already given which the boys should be allowed to execute, retaining the work when finished if they desire it. All the regular class products should be retained by the teacher for such future uses as the interest of the school suggests. They will often serve as the stock for other exercises.

When a boy actually spoils a piece, the teacher must decide on the spot whether he shall take a new "blank" and start anew, or adopt a modified design.

A difficult exercise may very properly be given twice. If the first exercises are duly criticised, and the prevailing failures are clearly pointed out to the division as a whole, the second attempts will far outweigh the first. If necessary, the teacher should re-execute the difficult points with the division looking on a second time.

In the list of exercises already given, I have included a sufficient number and variety for the school course. I claim for them no special excellence. They are tolerably logical, and show a decided tendency towards forms approved by best usage. No live teacher will follow them servilely nor will he be disposed to use precisely the same series twice.<sup>1</sup>

Much depends on the quality and dimensions of available lumber. After a little experience in teaching, it will be easy to decide where to introduce modifications. The teacher should not hesitate to adopt dimensions which will suit his lumber

---

<sup>1</sup> One of my teachers has taught wood-work for eight years, and he has never failed to introduce slight changes which he regards as improvements.

where mine fail to do so. Where I have given no dimensions, it is obvious that the teacher must assume them. In no case should the teacher fail to give all *necessary* dimensions.

#### CRITICISING AND MARKING THE SHOP-WORK.

In my judgment the mark given a piece of work should take no account of the personality of the boy beyond a general knowledge of the grade of the class. In other words the standard should be an *absolute one* for that grade. By reference to the grade, I mean that "perfection" signifies only "reasonable perfection," taking into account the age of the pupils, the amount of instruction they have received, the time allowed, and the quality of the lumber used. I should expect much more from a class of college Freshmen who averaged eighteen years of age, than from the youngest class in a manual training school who were only fifteen years old.

On the other hand, in giving a boy a quarterly or half-quarterly mark in shop-work, I should admit the lad's personality to a certain extent. For instance, I would mark him first without looking at his work; on his apparent comprehension of the exercises, as indicated by his written or oral answers to my questions;<sup>1</sup> on his drawings; on his care of his tools and bench; on the fidelity with which he followed instructions. Then I should consider this *personal* mark as of equal weight with the one derived from an examination of his finished work.

In marking a piece, say Fig. 17, I should take into account:—

1. The accuracy and finish with which the stock was squared up to the prescribed dimensions . . . . .	20
2. The style and correctness of the laying out . . . . .	30
3. The character of the sawing . . . . .	15
4. The chisel work . . . . .	15
5. The care of the finished surfaces (freedom from injury from the vise or accidental blows) . . . . .	10
6. The time spent . . . . .	10
	100

---

<sup>1</sup> Occasional written examinations are very desirable in the interest of correct vocabulary, precision of statement, and attention of details.



The laying out of complicated work should always be marked high. It is very desirable that the students know beforehand the system of marking, and just where their own shortcomings lie. Cultivate self-criticism by requiring of them that they mark their own work according to your analysis, comparing their pieces with yours, i.e., supposing that yours is nearly perfect, as it always should be. Of course the teacher should revise all such preliminary estimates of the young workmen on themselves.

#### APRONS, CAPS, BLOUSES, OVERALLS, TOWELS, ETC.

The pupils of a class should have aprons of a uniform style, coming well up to the chin, and descending to the knees; a light cap with a stiff visor (to protect the eyes from light and from flying chips); a towel (which should be changed once a week); and a cake of soap. All these when not in use should be kept in the student's drawer with his edge-tools. Blouses and overalls will not be necessary till wood-turning is taken up; they are then necessary to protect one's clothes from the fine chips which fly from the lathe.

The drawer keys used by the members of a division should be hung together on a key-board bearing the number of that division. The three key-boards should be kept by the teacher in his private closet, to be brought out in succession as the divisions appear. The presence of a key on the board after the division has been sent to the benches indicates the absence of a student. The keys should have tags numbered to correspond with the numbers on the drawers.

Pupils should be warned against dangerous methods of holding and using tools. The teacher soon learns what accidents are likely to happen, and he should warn accordingly. Under careful supervision, shop accidents are very few indeed.

Pupils should be warned not to slide the vise jaw unless the lever be thrown fully back, thus avoiding excessive wear.

All one's edge-tools should be kept in perfect order, and the teacher should attend to the saws as often as necessary.

Every boy should leave his bench perfectly clean, every tool in its place, and his private drawer in order. His shop duties

end after washing up, and locking his drawer, with the restoration of his key to the board, and with taking his place in the line for filing out of the room.

I have never found it necessary or desirable to give unsatisfactory students extra hours in the shop. A boy who under our regulations either can not, or will not, make fair progress is not worth the extra investment involved in extra hours; in either case I should try to get him out of the class.

While boys are at work in a shop I would allow no whistling nor playing nor idling. There is no objection to such conversation as may be necessary to the prosecution of their work. The essential thing is to keep the boys' minds on their work, and to rigidly exclude distracting influences.

The teacher should generally *not* be at work at his bench while the boys are engaged at theirs, but he should hold himself ready to answer a signal for assistance or advice, and to check and correct those whom he sees going wrong. The division should move on the stroke of a bell, promptly and quietly.

#### WOOD-TURNING.

I assume that the school is equipped with twenty-four speed-lathes driven by an engine. A boy of fourteen years can not *with profit* work long at a foot-lathe, without rest. Motive power is now so cheap and easily managed that no considerable supply of lathes should be put in without power.<sup>1</sup>

The construction and care of the lathe should be fully explained. A picture of our speed-lathe made by Messrs. Hall & Brown of St. Louis is shown as Fig. 36. Here the pupil learns, perhaps for the first time, the importance of keeping the lathe bearings in order and well oiled. The heating of a journal is never without cause, and should never be disregarded. The monkey-wrenches should be suited to the nuts on the lathes. The belt-shifters should be convenient and effective, and it should be made a second nature with a boy, to throw off the belt (shut off the lathe) at the slightest accident, or at

---

<sup>1</sup> For several years before the organization of the Manual Training School, the University boys used foot-lathes and hand-forges. In wood-work two students were put to one lathe, one driving while the other turned.

a slowing up of the main shaft. While a boy may properly use his hand to stop his lathe after the belt is off, he should be cautioned against getting his fingers or his sleeve under the belt. When not actually turning or marking his piece, he should stop his lathe. Let him beware getting his sleeve into the clutches of the spur-center. Flowing, or very loose, sleeves should not be worn. If properly shown, boys soon get the knack of shifting the belt to change the speed.

The stock with which one's wood-turning may begin should be about 2"  $\times$  2"  $\times$  8". After "centering" and placing one end on the spur, bring up the tail-stock, clamp it in place, and then screw up the center point till it strikes the center point in the wood. Force the stick firmly upon the spur. After withdrawing the tail center a trifle, clamp it and put a drop of oil on its point. Before starting the lathe put the tool-rest in place, its edge a little above the center line of the lathe and as near as possible without touching the wood. Pull the belt by hand, and see whether the piece and the rest are in proper position.

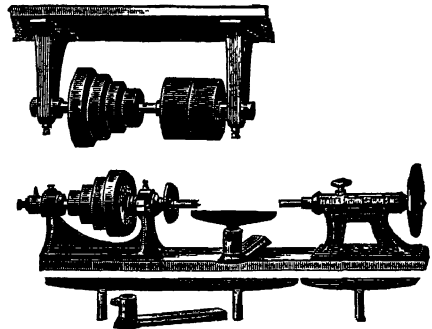

FIG. 36. SPEED-LATHE.

A carpenter's gouge is the first tool to be used; it is always to be used in roughing out. Turning tools should be kept sharp and free from nicks, and the pupil should early learn that he is to *cut* the wood, not *scrape* it; consequently the edge of the tool should be well raised almost into tangency with the revolving piece, and the tool should be slightly inclined *away* from where the diameter of the piece is larger, so as to avoid catching in the grain and splitting the wood; that is, one should work from a larger towards a smaller diameter. In roughing-off corners, cut lengths of about a half inch at a time, cutting towards an end at first and then towards the last out. The tool is to be held firmly resting on the guide, and as

it cuts is to be slid along parallel with itself. On no account should the pupil let the tool be knocked from his hand.

When the piece has been reduced to a cylinder, the tool may move along the whole piece without stopping, taking a thin uniform cut. If the piece has a cross grain or knots, the cut must be very thin, and the tool should move in the direction least likely to catch in the grain.

As soon as the piece is well roughed down, *stop the lathe*, and re-adjust the guide-rest. *Never adjust the rest when the lathe is in motion.*<sup>1</sup>

It is impossible for me to follow out the full details of the use even of the gouge. Two general directions must cover the whole ground:—

1. Cut, not scrape the wood.
2. Incline the tool, and work towards the *end* of the grain. Cut from the larger towards the smaller diameter, rolling the tool on the rest if necessary.

Before working to dimensions, learn to make every *kind* of surface: cylindrical, conical, conoidal (convex and concave), and square-shouldered; and to combine them at will. **QUALITY BEFORE QUANTITY** is the order of perception, and it should be the order of development throughout the school.

If much stock is to be taken off, the carpenter's gouge is the most serviceable tool. It carries a longer cutting edge, and subdivides the chips better than the turning gouge. Its peculiar advantages can be learned only by trial. The turning gouge is the tool to be used in corners from either the right or the left.

The turning chisel is a most effective tool, yielding a very smooth surface and enabling one to work to sharp angles and square corners, but it is more liable to catch on the grain than the gouge.

The teacher must introduce the several tools gradually, showing the special uses of each, the accidents that are peculiar to each, and how each is ground and oil-stoned.

---

<sup>1</sup> One of our boys disregarded this rule, and lost a finger-nail thereby. He raised the rest with the fingers of the left hand, and then pushed it forward till a finger came in contact with the swiftly revolving piece. In an instant the nail was gone!

One of the first things to surprise a learner, if he is using hard seasoned wood, will be the easy generation of heat. In turning a mallet-head of dry oak, for instance, the chisel or the gouge may become so hot as to lose its temper. Great care must be taken in cutting creases for shoulders, or the chisel will be temporarily ruined. The creases should be cut a little at a time, and the tool should be quickly withdrawn. If, unfortunately, the temper is drawn from a portion of the edge, the injured part must be ground away. The use of heat developed by friction as a means of coloring rings and beads on the work is soon learned. To save his tools, the teacher should make "*Heat*" the subject of a class-lecture, and he should call general attention to every instance where a neglect of orders has produced bad results. A tool may be seriously injured by frictional heat when cutting soft, dry pine.

I have thus far assumed that the grain of the wood is parallel with the axis of the lathe. Blocks in which the grain is at right angles to the axis of the lathe are generally driven by center screws which are attached to the face-plate which is put on after the spur-center is removed; or the block is secured to the face-plate by short screws. One of these methods is employed whenever a piece is to be wholly supported from one end, and the tail-stock is either removed or pushed to the end of the bed. Great care must be taken to keep the edge-tool clear of the center and face-plate screws.

In turning across the grain, the tool for obvious reasons should be carried very nearly parallel with the axis, and the tool-rest should be adjusted across the end or face of the piece.

Interior turning should generally be done by the "round-nose" tool, at least as a preliminary tool. In spite of its scraping action, it should be kept well ground to a somewhat shearing edge. A large cavity in the end of a piece should be "cored out;" i.e., an annular channel should be taken out by the round-nose, only slightly-less in exterior diameter than the required cavity, and then the central part or core can be undermined and split out. Experience will soon teach that in turning a goblet or a vase, the portion farthest from the support is to be finished first.

## CHUCKING.

Pieces like spheres and rings often require turning over their entire surface; hence they must at least during a part of the work receive other support than the screws and centers already named. It is usual to fit them into a "chuck," which consists of a separate piece of wood screwed to the face-plate, and having in the center of its face a cavity so fitted to the size of the article to be turned that the latter requires a gentle forcing into it, with friction sufficient to hold it securely while under the turning tool. A little experience will enable one to fit a chuck readily, and to use one surprisingly shallow. Several examples of chucks are given in the exercises illustrated below. One chuck with a little refitting will often serve several pieces.

Sometimes a mandrel is used to support and carry a piece which has a central hole. A "mandrel" consists of a cylinder of wood fitting snugly a hole in the piece to be turned, and carrying it with itself as it revolves in the lathe. In replacing the mandrel in the lathe after having removed it for any cause, be careful to restore it to its exact former position. Always use soft wood for a mandrel, and bear in mind that a little friction is sufficient to carry a piece round.

By the use of a monkey-wrench on the shaft of a bit, and a small block fitted against the tail-stock spindle, the face of a piece mounted in the lathe may be quickly and accurately bored; but the bit should first be passed through a sleeve or tube which will allow it to enter only to a certain depth. The rapidity with which the boring is done renders this precaution necessary. Or, on the other hand, a bit may be mounted in the center of a face-plate, and be used for boring holes in a piece which rests against the tail-stock. In this case also a sleeve around the bit should serve as a "stop" at the limiting depth.

As a rule, delicate work is best executed in hard wood. The lumber should always be well seasoned, and when finished articles are to be preserved, they should be well varnished. "Built-up" pieces of black walnut, and light-colored wood, such as maple, beech, ash, chestnut, or oak, alternating in thin strips

and firmly glued, serve admirably for ornamental work. The contrast of colors and grains is very effective.

When a fair quality of workmanship has been attained, the teacher may proceed to specify *quantity*, and require pieces to conform to given dimensions as shown in drawings. Thus far in wood-turning, I have assumed only free outlines, which the teacher may sufficiently show by free-hand curves on the black-board. As soon as dimensions are used, however, the pupils must make careful scale and figured drawings in their books. As turned objects are symmetrical with respect to a line (the axis), their projections (on a plane parallel to the axis) are symmetrical also; hence it is customary to draw but one half, unless a section is required, in which case one half of the drawing shows an exterior projection, and the other half a section through the axis. As this method of drawing may be unfamiliar, I will insert in the illustrations to the turning exercises a drawing of a goblet, one half being in projection, and the other half in section. See Fig. 53 on p. 65.

Gum-wood, white and black, is excellent for turning, as it splits with great difficulty, but it must be kept perfectly dry. Fancy woods for ornamental work are cedar, cherry, rosewood, boxwood, and mahogany. Hemlock would make beautiful work if free from checks. Dead knots should be carefully removed by a hatchet or saw.

There is great opportunity for economy of material in wood-turning. The product of one exercise may be made the basis for another. See Figs. 49 and 50, where one piece is made to serve as the basis of several distinct exercises. In the end we shall have mainly worthless *chips* and valuable experience. As we never have much more left, this should produce no sense of disappointment. A few specimens should be kept, however, to illustrate the series and to emphasize good work. A finished piece tells a plain story to a practised eye, and when the story is a good one, it is exceedingly stimulating to the class to see that it is duly recognized.

All that I have elsewhere said (see p. 52) in regard to care of tools, bench, marking, etc., applies as well to one kind of wood-work as another. The following series of turning exer-

cises will fairly serve to begin with. After a year's experience the teacher will need no guide. He will receive abundant suggestions from many sources, and will see changes which, for the time at least, will appear to be marked improvements.

#### EXERCISES IN WOOD-TURNING.

With one or two exceptions these drawings show but half-projections, the lower line being the axis of the piece. The drawings have been furnished me by Mr. Charles F. White of the St. Louis Manual Training School. They are intended to furnish opportunity for learning the use of all the tools, and to cultivate a taste for graceful curves and an eye for symmetry. They may be executed in soft or hard woods, plain or built-up by gluing.

The first twelve drawings represent pieces from six to ten inches long. Only newly-used tools are mentioned.

**No. 1. (Fig. 37.) Plain cylinder. Carpenter's gouge.**

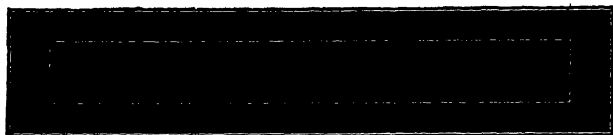

FIG. 37.

**No. 2. (Fig. 38.) Cylinders and cones. Turner's gouge.**



FIG. 38.

**No. 3. (Fig. 39.) Stepped cylinders. Wide chisel.**

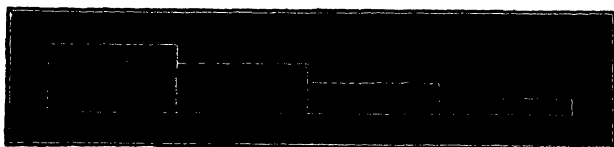

FIG. 39.



No. 4. (Fig. 40.) Double-stepped cylinders.

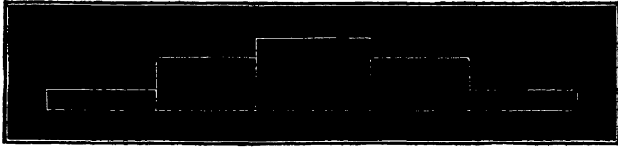

FIG. 40.

No. 5. (Fig. 41.) Large and small cylinders.

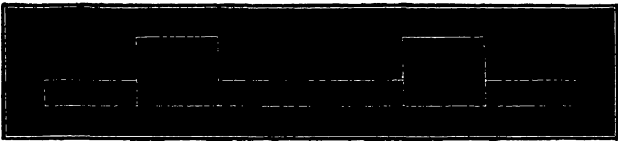

FIG. 41.

No. 6. (Fig. 42.) Convex curves.

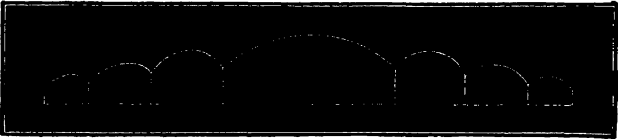

FIG. 42.

No. 7. (Fig. 43.) Beads, cones, and cylinders.



FIG. 43.

No. 8. (Fig. 44.) Convex and concave curves.



FIG. 44.

No. 9. (Fig. 45.) Flowing or reverse curves.



FIG. 45.

No. 10. (Fig. 46.) Reverse curves. Small baluster.

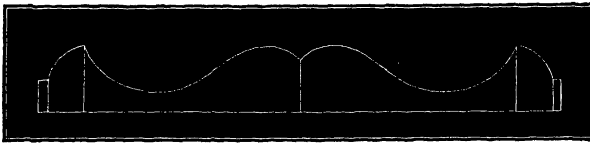

FIG. 46.

No. 11. (Fig. 47.) A baluster pillar. This may be lengthened into a table-leg.

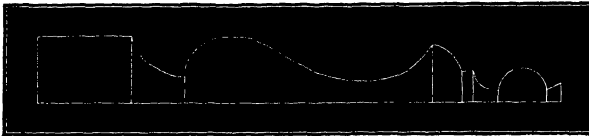

FIG. 47.

No. 12. (Fig. 48.) Baluster without base.



FIG. 48.

No. 13. (Fig. 49.) Face-plate work. This is turning across the grain. Each of the drawings represents a half-projection. The screw shows how the block is fastened to the face-plate. (a) represents a plain solid cylinder. (b) shows two cylinders, a square corner having been turned off. (c) shows that each of the sharp corners has been turned away, leaving conical bands. (d) shows that the corners have been turned off, leaving

an ogee outline. (e). The outline is modified into a capital molding, and a cylindrical cavity is sunk into its face as tho to fit the top of a pillar or column.

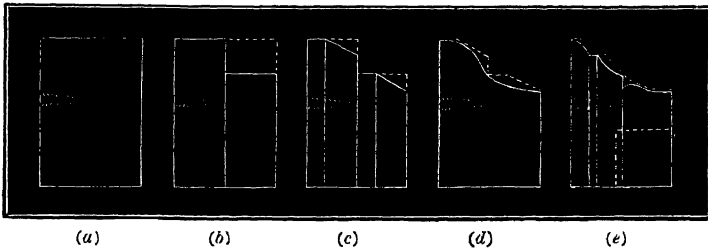

FIG. 49.

**No. 14. (Fig. 50.) Chuck work.** (a) represents a half-section of a block on the face-plate screw. The exterior has been turned off into three stepped cylinders, and a cylindrical opening has been sunk into its face. We must now suppose that a two-cylinder opening is wanted in the back, or left-hand side. The block must then be taken off, turned round, and inserted in a *chuck*. (b) shows the chuck screwed to the face-plate and partially cut out. For the sake of the practice, the

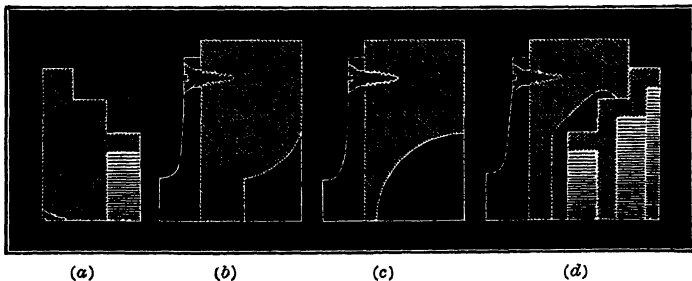
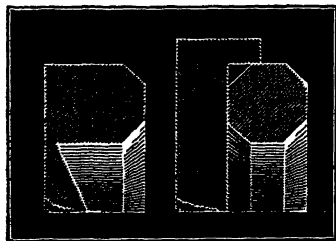

FIG. 50.

chuck-cavity may be made to take the form of (b), showing a convex outline; or concave outline as shown in (c), where it is a hemispherical cavity; or (d), where it has just the form to support without injury the first piece (a). When the piece is accurately carried by the chuck, the double cylindrical opening may be cut out of the original piece, leaving but a skeleton of material in the finished piece. This exercise is very interesting, and admits of great variation.

**No. 15. (Fig. 51.)** Ring with octagonal section. This figure, like the last one, shows a half-section of the ring.



(a) (b)

FIG. 51.

(a) shows that the ring is partly formed from the face of a block screwed to the face-plate by the center screw. Three of the faces of the ring are finished, and two more, the inner and the outer, are accurately turned. Perhaps the outer one should be defined by a faint line before it is removed from the screw. (b) shows that

a chuck has been made to receive it after it is turned round, and that the original back of the block has been cut away, and that the ring has been finished.

**No. 16. Napkin ring.** This should be shown in half-section and in half-projection. It is treated like the ring in Fig. 51; that is, it is held by the screw-center till the interior and the greater part of the exterior is finished, and then it is turned round, and the finished end is inserted in a chuck. For this exercise use close-grained hard wood, and polish, stain, or shellac the result.

**No. 17. (Fig. 52.) Sphere.** The sphere is shown in projection; the chuck, in section. This is a difficult exercise, and

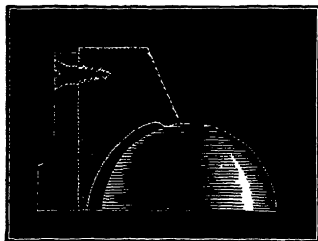

FIG. 52.

should not be undertaken till the class has had considerable experience in chucking. As in No. 14, the chuck may be a valuable exercise in itself. The sphere may be approximately turned between two centres. It may then be placed in a chuck, as shown in the cut. The circle of contact is a little less than a great circle. The sphere

should be moved in the chuck so as to take all possible positions, and be tested thoroughly, before it can be considered finished. Spheres turned from built-up pieces of light and dark woods are very pleasing when well done.

**No. 18. (Fig. 53.) Goblet.** This is shown in half-section and half-projection. It may be wholly turned from the screw-center of the face-plate. The parts farthest from the plate should be finished first. Cedar, mahogany, cherry, gum, rose-wood, oak, and black walnut are good woods for goblets and vases, tho I have seen beautiful work of this description executed in white pine; cedar splits easily, but has a fine color.

**No. 19. A composition or design.** At this stage of his work the pupil has a clear idea of what he would like to make for a final or "show" piece. This "show" is not to be a vain parade, but the actual combination of his exercises into a work of both use and beauty. The pupil should early learn that Use and Beauty should never

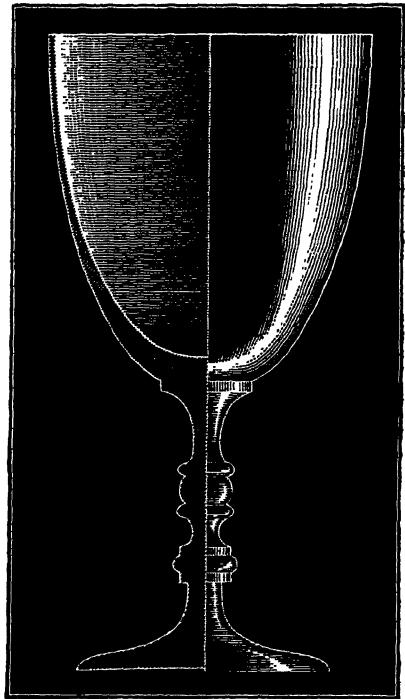

FIG. 53.

be divorced. Every blossom should be the promise of fruit; so every fruit should be heralded by a beautiful flower. It is altogether probable that his turning exercises have opened the pupil's eyes to see and analyze forms of grace hitherto unnoticed. Handsome furniture, moldings, cornices, pillars, rounds, balusters, posts, etc., have been examined with wondering delight. The boy finds so much that pleases him, so many graceful combinations, that in his first design he will probably load his piece most extravagantly. Nevertheless, give him a reasonable caution not to ornament too much, and then let him have his will. He will soon see how superior is simple grace and fair proportion, and yet how difficult it is to satisfy a critical eye. A balustrade, a hat-rack (for fastening on a

wall), a small table, a toy bedstead, a spoked wheel, a set of chessmen, a nest of thin boxes with covers, — such are some of the things which may properly be chosen for the display of one's skill. Whatever is taken, require first a figured drawing made carefully to large scale.

#### WOOD-CARVING.

Considerable wood-carving may be done with ordinary bench tools, tho fine work should not be attempted with coarse instruments. The great thing is to learn how to work with the grain, and how to hold the tool for grooving or paring. The piece to be wrought upon is to be firmly supported in the vise, and the cutting-tool is usually to be driven along by the hand. Occasionally a light mallet may be used.

**No. 1. A gouge exercise.** Fig. 54 shows a variety of work upon one block, by means of which one learns to take the grain at all angles. The gouge is the main article to be used. All surfaces should be left smooth or polished. The block is about six inches long.

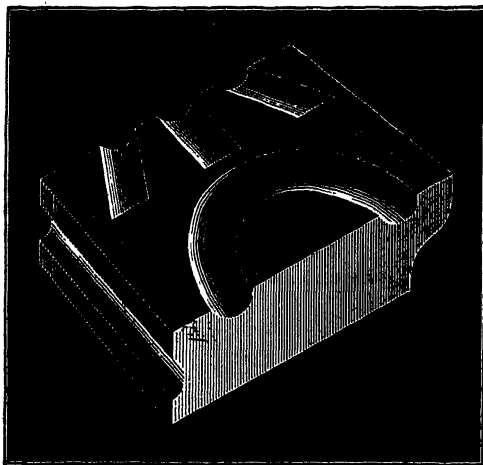

FIG. 54.

**No. 2. A gluing and chisel exercise.** Fig. 55 shows a piece composed of eight strips matched and glued, and afterwards dressed with the wide chisel and polished. The drawing

shows the variety which may be worked into one piece. The effect of the gluing is very striking if dark and light colors alternate in the shield.

In any event, wood with clear grain should be used, and the surfaces should be polished so as to bring out the beauty of the wood.

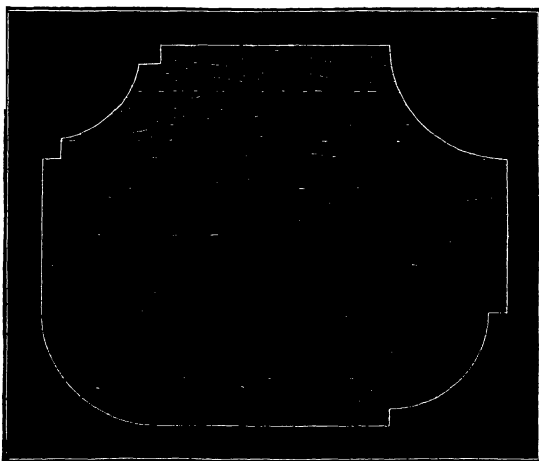

FIG. 55.

There is a great variety of special wood-carving tools, tho in school the number need not be large.

The tools used may vary somewhat; those selected for the class in the St. Louis School are the following. The numbers refer to the standard numbers on the imported "London tools."

#### WOOD-CARVING TOOLS.

- No. 1.  $\frac{1}{4}$ " firmer (straight chisel).
2.  $\frac{3}{8}$ " corner firmer (diagonal chisel).
3.  $\frac{3}{4}$ " straight gouge (flat).
5.  $\frac{1}{2}$ " straight gouge (less flat).
8.  $\frac{1}{2}$ " straight gouge (round).
9.  $\frac{3}{8}$ " straight gouge (round, more curvature).
11.  $\frac{1}{2}$ " straight gouge (sharply curved).
11.  $\frac{1}{4}$ " straight gouge (sharply curved).
28.  $\frac{1}{8}$ " short bent gouge.
39.  $\frac{3}{8}$ " parting tool (triangular edge).

The tools used by Mr. House of the Toledo Manual Training School are somewhat different.

The material may be soft woods, such as gum, elm, poplar, or pine, the first two of which split with great difficulty. The later exercises may be in harder wood, such as black walnut, mahogany, rosewood, or oak, — the last being preferred for high relief: but exercises in high relief should usually be deferred till a subsequent course in an art school.

I am indebted to Mr. N. W. House of the Toledo Manual Training School for the following series of graded elementary exercises with regular wood-carving tools. They have served as the basis of our exercises in this direction during the past year.

The thickness of the wood varies in the different exercises from three-eighths to three-quarters of an inch.

**No. 3. (Fig. 56.) Grooving across the grain.** Use straight gouge,  $\frac{1}{8}$ " wide, No. 11. In every exercise first lay out the work in pencil.

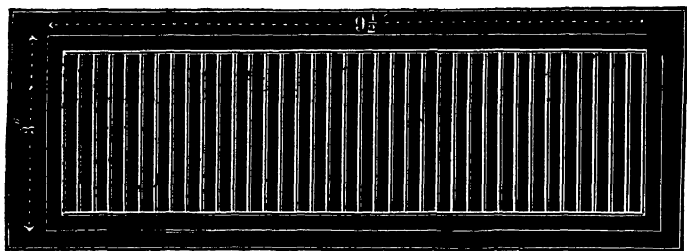

FIG. 56.

**No. 4. (Fig. 57.) Grooving with and across the grain.** Use straight gouge,  $\frac{1}{8}$ " wide, No. 11. Cut, not split, the wood. Keep the tool sharp, and *work* the tool along *wholly* by hand.

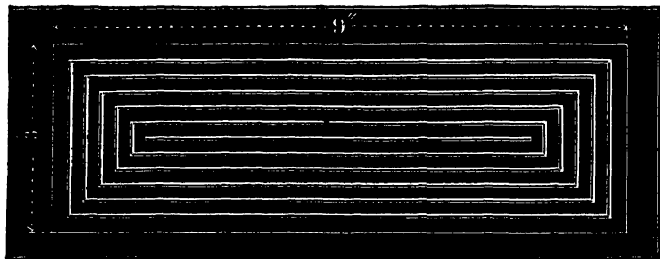

FIG. 57.



**No. 5. (Fig. 58.) Circular grooving.** Same tool as before. Carry the tool as a tangent to the curve. Practice cutting *right-handed* and *left-handed*.

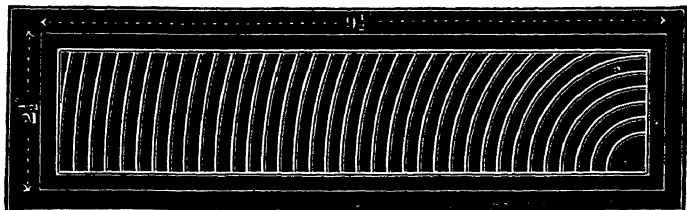

FIG. 58.

**No. 6. (Fig. 59.) Convex panel, with tracery.** Use two gouges and the parting-tool. Conduct the exercise in two parts: *first*, produce the convex panel; and *second*, the compound shaded grooves which should be drawn on the convex surface.

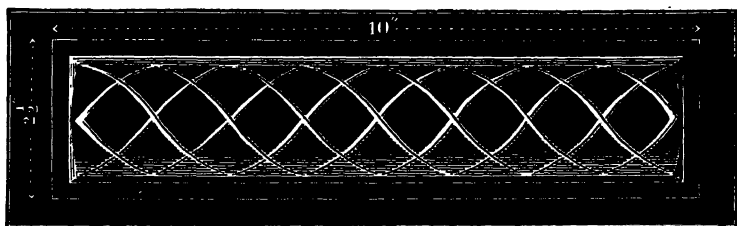

FIG. 59.

**No. 7. (Fig. 60.) Engraved panel.** The two corners are carved. The sweeping grooves are clear cuts of varying depth, made by the parting-tool. The intervening cuts are made with a flat gouge.

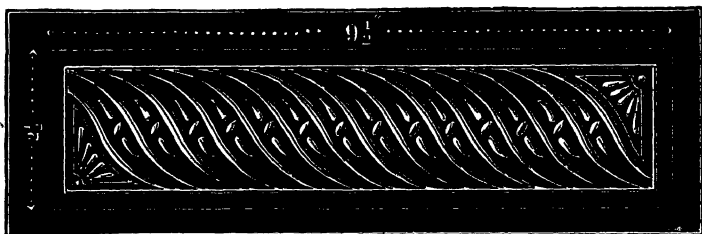

FIG. 60.

**No. 8. (Fig. 61.)** Panel with engraved tendril. Use two gouges, cutting grooves of varying depth.

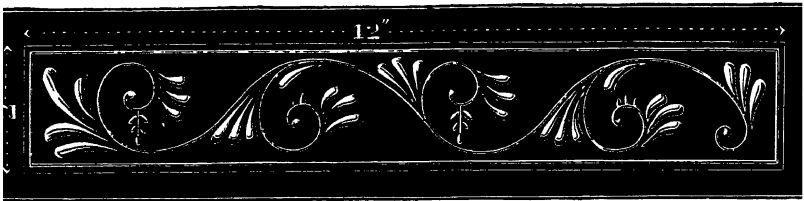

FIG. 61.

**No. 9. (Fig. 62.)** Carved square panel. Quadrifolium in relief. Use two gouges and a straight chisel. The edges of the panel are plain bevels. The edges of the leaves are slightly under-cut. The panel is sunk about one-fourth of an inch. The center is hemispherical. The ground is roughened by a spike having a large number of small projections on its end.

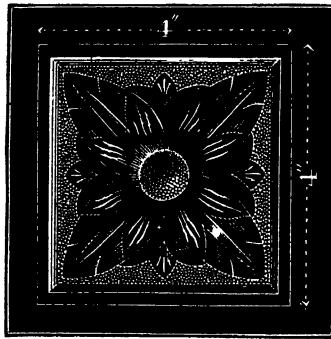

FIG. 62.

**No. 10. (Fig. 63.)** Panel with carved vine. The vine is in sharp relief. Leave all corners clean and smoothly cut.

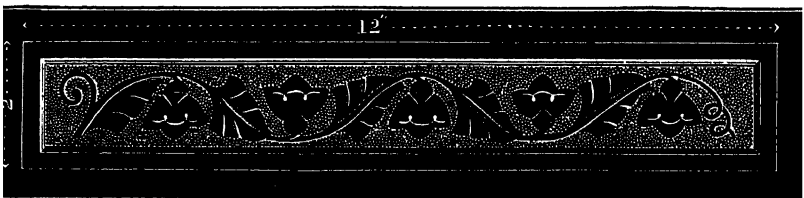

FIG. 63.

**No. 11. (Fig. 64.) Concave circular piece.** The corner designs are engraved; the central parts carved out to a depth of one-quarter or three-eighths of an inch. The ribs and circumferences are cut deeply, while the rosette in the center is in relief. The center is convex, rising to a blunt point, with sharp shaded grooves running to the apex.

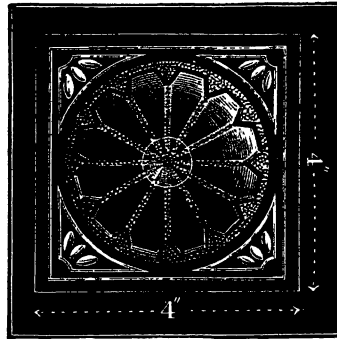

FIG. 64.

**No. 12. (Fig. 65.) Carved diagonal panel.** The corners are carved, the triangular borders being beveled, and the radiating panels being convex upward. The rhomboidal panel

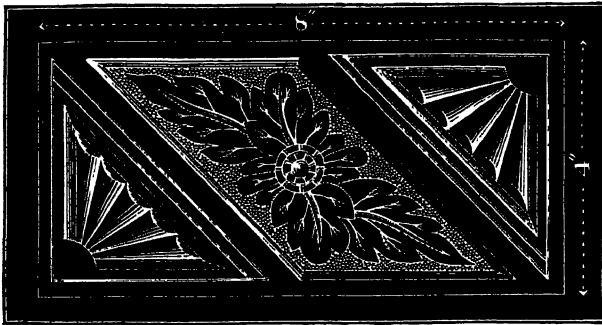

FIG. 65.

is deeply carved with overlapping leaves, sharply under-cut. The "corner-firmer" is especially useful in finishing sharp corners when under-cut.

Oiling the portions in relief gives them a rich appearance, and

at the same time brings into prominence the poor finish of surfaces.

The time given to wood-carving is about four weeks. As an alternative with carving or engraving wood, I suggest the introduction of several exercises in carving plaster-of-Paris blocks. The scale of the details should be increased.

It is possible that the reader who has followed me so far will be surprised to find the first year at an end without that *useful work* which he has all the time assumed we should do before the year should close. He feels, perhaps, that all we have done thus far has been in the nature of *getting ready* to do something. Perhaps he wonders why the boys have not made themselves bureaus, desks, and chairs, or supplied their homes with useful articles and with pretty pictures.

As I shall discuss this subject later on quite fully, I must refer him to the later chapters. However, I have no objection to final pieces, which combine the principles and methods contained in the exercises, and which serve to show the pupils themselves the value of what they have got. But to make the production of articles the main object, and the learning of principles and methods incidental, would be to choose the shadow rather than the substance; to destroy our school by converting it into a factory. No, this is a school; its object is education. Doubtless the world will have work for these boys to do when they get outside; let us give them the *power* to do it well.

## CHAPTER III.

## THE SECOND, OR MIDDLE YEAR.

THE careful reader of the last chapter will read much between the lines of this. The same general principles are to be followed, and in the details of the work many of the methods will be the same. The pupils are a year older; they are considerably larger, for their physical development is going on at a maximum rate; they have made some progress intellectually and manually, but a good deal more morally, in confidence and self-assertion. They need firm, kind, sympathetic management. The work of the year is quite new, of great interest, and sufficiently difficult to yield healthy discipline.

Of course I assume the full work of the previous year; unless it has been fairly done, the boy should not be in the middle class. In deciding the question of promotion, all matters should be taken into account; at the same time, it should be admitted that the mathematical and other sequence studies afford the chief criterion. Without mathematical success the work of the second year cannot be done. It is a mistake to *insist* upon excellence either in the direction of practical mechanics, or in memory studies, such as language and history.

If the student has any brains at all, he is likely to do well in something, and a partial failure in a single direction should not prevent his going on in the course. Pupils have very different gifts, and the discovery of these gifts should be followed by prompt recognition of them. Instead of trying to force all comers into the same Procrustean mold, it is our duty to give each full liberty of growth. If a boy fails in the shop but succeeds in his Latin, or *vice versa*, he ought still to go on, if physical strength and fair mathematical power are not wanting. But

here let me say that almost without exception, mathematical and mechanical power go together. If a boy fails in the shop, he is quite sure to be weak in arithmetic and algebra; but it is not at all sure,—it is scarcely probable,—that one who is a manual failure is weak in language and history and spelling. Manual failures seem to arise from a lack of power to appreciate precision and logical order. A boy deficient in mechanical power rarely asks “why?” One way appears to him about as reasonable as another; he adopts a certain order because some one else did, or because he was told to do so. He bows to authority. When his work is compared with good work, he sees no great difference; he does not see that an eighth of an inch more or less does any harm, or that  $80^\circ$  or  $100^\circ$  is not as good as  $90^\circ$ . Hence it is that in our promotions from class to class, it is not necessary to lay great stress upon shop-work. Every well-balanced boy does passably well in it, and the sequence of the work of different grades does not demand great proficiency. Besides, as already said, the pupil may never have had any shop opportunities before, and it may take some time to bring out his innate faculties. Physical maturity (i.e. command of one’s muscles and motions) comes at very unequal ages in different boys. Great size is not maturity; a six-footer is often the personification of physical immaturity.

For the sake of consistency and simplicity I shall assume that the number of the second or middle class has fallen from seventy-two to sixty-six, and that it consists of three divisions of twenty-two each. As before, three teachers are necessary: one exclusively for the shop,<sup>1</sup> and two for the drawing and book studies. Other things being equal, I would have the teacher of physics teach the drawing; for the reason that the correct study of physics involves the examination and execution of drawings, in connection with the design and construction of physical apparatus, and the record of physical experiments.

The science study for the year is physics. The mathematical

---

<sup>1</sup> It is better *not* to divide the shop-work between two teachers, even if both are competent; there should be no divided responsibility in the care of the tools, the material, and the shop generally. When only one man rules the shop, every thing is more likely to be well in hand.

study is elementary algebra continued through quadratics, and a few weeks' work in geometry.

The language work is, on the one hand, the reading of three Books of Cæsar and perhaps an oration of Cicero, with continued study of the Latin grammar. On the other hand, rhetoric with frequent almost daily exercises in English composition one term, and history (English) one term.

In the place of Latin and rhetoric (or history), all take modern classics once a week.

The daily program is as follows:—

SECOND YEAR PROGRAM.

DIVISION.	9-10.	10-11.	11-12.	12-1.	1-2.	2-3.	3-4.
I.	Shopwork.		Physics.	Latin.	Recess.	Drawing.	Mathe- matics.
II.	Physics.	Algebra.	Shopwork.			English.	Drawing.
III.	Algebra.	Drawing.	English or Latin.	Physics.		Shopwork.	

The recitations should occupy forty or fifty minutes each; the drawing, a full hour; the shop, two hours.

I assume that one division is wholly Latin, another wholly English; the third should be wholly one or the other, or a fourth teacher must step in to take a subdivision of the class.

If the physical laboratory will admit more than twenty-two pupils in a division, there may be between eleven and one o'clock a special re-arrangement of the first and third divisions, which will admit of a few *more* or a few *less* than twenty-two in the Latin division.

All the *mechanical* details of English composition should be thoroughly mastered this year, even for the Latins, the literature hour being used for that purpose as far as necessary. Teachers must never forget that English composition like every thing else in and out of school is not learned by the continued practice of faulty methods and an endless repetition of errors,

not even if one's results are unfailingly pronounced wrong, and so marked. One learns a correct method only by practising a correct method, under dictation if necessary. Every error should be fully and clearly corrected by the pupil himself.

The teacher should always *invent* a new exercise (and this remark applies to English composition, to shop-work, to mathematics and to Latin alike), in which the pupil may have an opportunity to avoid certain specified old errors, and follow the best usage. Don't try to "catch" a boy when he is unaware, by giving him a chance to repeat an old error; but lead him consciously to correct usage.

The persistence of error is something remarkable. I have known a workman follow a wrong method all his life, tho strongly suspecting that it was wrong. I know intelligent people by scores who have standard errors of speech which they will never live to correct. I have known a poor cook remain a poor cook for years, tho daily practising her art (?). One hour of correct *doing*, under the eye and direction of a teacher, is worth more than months of mere criticism, and crude attempts to find the Correct Way by the Broad Road of Error.

Some teachers will never tell a pupil the plain, simple truth about an article, or method, or process (which may after all be largely a matter of conventionality) until he has badgered his brains in trying to *invent* it or to *think* it out, or has exhausted his patience in futile "guessing." Some teachers even emphasize wrong ways more than right ones. Such teachers of How-Not-To-Do-It should be muzzled, or at least put under bonds not to "keep school" any more.

#### TEACHING PHYSICS.

I cannot forbear a few words about the correct teaching of physics. It is only in a manual training school that the method which appears to be the only correct one can be advantageously followed. Nowhere else are pupils so ready to devise, construct, interpret, explain, and use physical apparatus. Studying physics without handling and using apparatus is like eating a meal of cook-books. It doesn't nourish; it sounds well, but there is no real knowledge in it. Concepts which for the most



part ought to be primitive, first-hand, are only second-hand, or third-hand, or mere speculation. Until one gets a certain amount of mental stock on hand in the shape of exact, experimental knowledge of certain things, properties, forces, processes, and relationships (which are very imperfectly expressed by certain more or less technical terms), he cannot appreciate properly verbal accounts of the experiments and conclusions of others. The drawing of a piece of apparatus is far inferior to the apparatus itself, at least to elementary students.

In the St. Louis Manual Training School, the study of physics is becoming more and more a matter of personal observation and personal experiment on the part of the individual pupils.<sup>1</sup>

#### SECOND YEAR DRAWING.

The drawing of the Second Year consists of several new features, notably: projections of intersecting or truncated geometrical bodies (cylinders, pyramids, cones, and prisms); the development of surfaces; brush-tinting; mosaics and tracery; isometric drawing; detail drawing, and drawings for patterns; graining and ornamental lettering; and some study of historical forms in architecture.

I do not deem it necessary to go into a full account of this work. The competent teacher needs no analysis of it; and the incompetent teacher will probably let it alone. I desire, however, to warn against undertaking too much. The groups of blocks, for instance, may be purely ideal, and they can easily be made very difficult. My advice is to leave complicated work to classes in descriptive geometry proper.

The work should all be done in pencil and then in ink on

---

<sup>1</sup> Under the guidance of Mr. C. C. Swofford, who last year conducted four divisions of physics. At the close of the year there was a remarkable display of quite elegant and perfectly serviceable apparatus, constructed by the class, in most cases from original designs. The apparatus was explained by the makers and used by them before a large audience.

It is hardly necessary to add that Mr. Swofford could not have succeeded thus with a class of boys who had had no training in the use of tools, and who could neither make nor read working drawings.

Our physical laboratory contains an engine lathe, a speed lathe, a hand planer, a long bench, two vises, and wood-working and iron-working tools. A small upright engine, built by a third-year class, drives the lathes and a dynamo.

stretched paper, with great accuracy and good lining. I add a few of the exercises purely geometrical, given for the sake of cultivating the geometric imagination.

1. *Triangular prism leaning against a cube.* Find three projections. Dimensions of solids should be given.

2. *Hexagonal prism leaning against the base of a quadrangular pyramid which rests on a face.*

3. *Circular cylinder leaning against a cube.*

4. *Prism lying on the top of a cylinder while a pyramid leans against it.*

Though it is not necessary to follow the exact dimensions of wooden or plaster models, it is very desirable that real models be used to illustrate not only the nature of the bodies, but the nature of the groups to be drawn.

In order to get three accurate projections with proper regard to visible and invisible lines, some purely "construction" work must be done; it is well if these latter are inked in red.

For the benefit of interested readers who are not draughtsmen, I will give the specifications and drawings of the second of the above.

**PROBLEM:**— *To find the orthographic projections of a hexagonal prism leaning against the base of a quadrangular pyramid, which is lying on a horizontal plane.*

**SOLUTION:**— Let the pyramid have a base 2" square. (Execute the drawing full size.) Let it be so placed that the side projection (elevation) of the base shall be a single straight line ( $s' c'$  Fig. 66). (This should be illustrated by the model.) Let the altitude or center line of the pyramid be  $2\frac{1}{2}$ ". Imagine this line drawn perpendicular to the base from its center. Its projection on the side plane will be  $2\frac{1}{2}$ " long, and will at one end bisect the projection of the base at right angles, while the other end will touch the *ground line* ( $G L$ ). There are several ways of finding the correct position of the side projection of the pyramid; perhaps the pupil had best draw it in pencil in its erect position, and then *turn it over*. In the figure it is drawn with dotted lines in an inverted position, and then turned down.

The top view (plan) of the pyramid is now readily drawn.

The base is  $s c d h$  and the apex is at  $v$ . It will be noted that two of the edges  $s v$  and  $h v$  are invisible to an eye directly above the object.

Thus far I have taken no account of the prism, which will of course hide a part of the pyramid, in some or all of the views. It is therefore best even in pencil to draw the lines faint and broken. Now not to make the problem too hard, take the prism so that it has a *line* contact with the horizontal plane on which they both rest. (Illustrate this by models.) One line ( $r' p'$ ) may now be assumed on the side plane. Suppose the base to

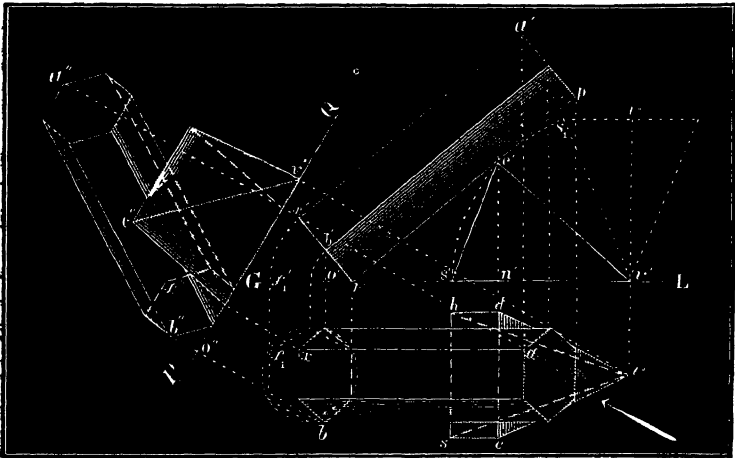

FIG. 66.

be a regular hexagon whose side is  $\frac{3}{4}$ ", while the edges are  $3''$  long. Assume the position of the lowest side of the base, and draw the base as tho the prism stood erect. (See dotted base full size.) In this position, its side projection is in  $G L$ . Next revolve it up to its required position. (This operation is shown by the circular arc  $x', x''$ ). The entire side projection may now be correctly drawn,  $r' b' x' a'$  etc. There are no invisible lines which are not covered by visible ones. The *plan* or top view of the prism may now be drawn, by means of perpendicular and parallel lines. It is easy to see which lines in the plan are to be drawn full, representing visible lines, and which broken. The reason why the horizontal projections of

the long edges are parallel to  $GL$  will be readily seen from the models in front of a side plane.

A third, or end projection, may be drawn, not because it is necessary to full representation, but for the mental exercise.

It may be very instructive for the pupil to see that a projection may readily be drawn on *any vertical plane*. For instance, suppose one looks at the group obliquely, but still horizontally, from the right front, in the direction of the large arrow. The projection is shown beyond the line  $PQ$ . The heights of the points above  $PQ$  are the same as the distances of the same points in the side projection from  $GL$ . In this view I have omitted some invisible lines, and have put double accents on the letters.

The next regular sheet should contain truncated solids and their developments. For the first exercise it may be well to develop the entire surface of a regular solid. In the second show a prism cut by a plane. Its lateral surface below the cutting plane is to be developed, or *rolled out*, and the full size of the inclined section is to be shown. The drawing is easier than the following, which shows a truncated irregular pyramid and its development.

**PROBLEM:** — *To cut an irregular pyramid by a plane, to find the true size of the section, and to develop the surface of the truncated pyramid.*

**SOLUTION:** — Fig. 67 shows the full operation, which should be executed on a scale about three times as large, and with all possible accuracy. The central part of the drawing shows the plan and elevation of the pyramid, the vertex being  $0, 0'$ , and the base  $1, 2, 3, 4, 5$ . The intersecting plane cuts the edges in the points  $6, 7, 8, 9, 10$ . The points  $10$  and  $10'$  are of course in the same perpendicular to  $5', 2'$ , and so for the other points. To get the full size of the section I draw through  $1$  in the base a broken and dotted line parallel to the ground line; and at any convenient distance from the elevation a second broken and dotted line parallel to the cutting plane  $7', 10'$ . From the points in the plan  $6, 7, 8, 9, 10$ , I draw perpendiculars to the new line through  $1$ . These perpendiculars measure the hori-

zontal distances of the points from a vertical plane through 1. Through 7', 8', 6', 9', 10', draw perpendiculars to and *beyond* the parallel line, and make the portions beyond the line just as long as the *corresponding distances* last referred to in the plan. You will thus determine the points 7, 8, 9, 10, 6, and by connecting them you will have the *full size of the section*, shown at (a).

In order to develop the lateral surface, we must find the true length of the edges of the pyramid, both the parts cut off, and the full length. This is done by means of the perpendicular and inclined lines on the left near (b). The lines are put off by

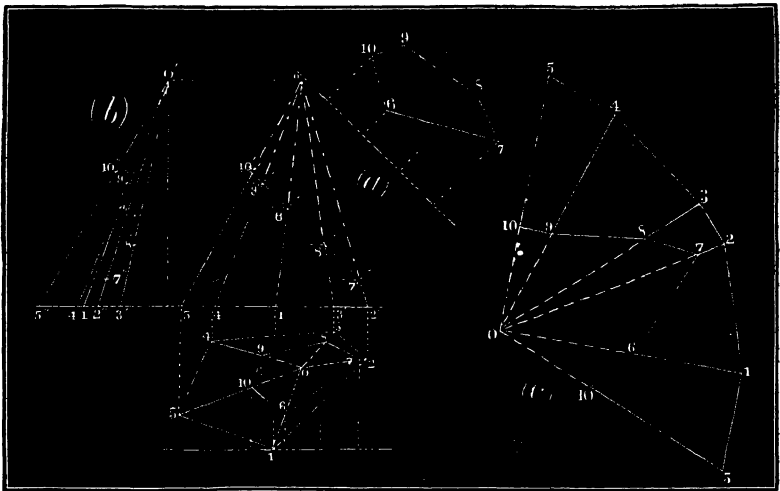

FIG. 67.

themselves to avoid confusion. The perpendicular measures the altitude of the entire pyramid. The inclined lines represent the *edges* of the pyramid, which are supposed to be swung round the altitude line till they are parallel to the side plane. Thus the distance from 1'' to the foot of the perpendicular is equal to 0 1 in the plan; and 0'' 1'' gives the *full length* of the edge 0 1, 0' 1'. From 6' a line is brought along by the T-square to 6'', and then we have the distance 6'' 1'', as the true length of the edge between the point 6 and the point 1. Similarly all the true lengths are found.

At (c) we have the development of the surface supposed to

be cut open along the edge 0, 10, 5. It is constructed thus: Draw 0 5, Fig. (c) equal to 0" 5", Fig. (b), and make 0 10 equal to 0" 10". Next determine the position of 1, Fig. (c), by making 0 1, and 5 1, respectively equal to 0" 1" in Fig. (b), and 5 1, in the base of the pyramid.<sup>1</sup> The point 6, Fig. (c), may then be found by making 0 6 equal to 0" 6", Fig. (b), or 10 6 equal to 10 6, Fig. (a). The two methods should check. We have now in 5, 1, 6, 10, Fig. (c), the full size of the four-sided face shown in the plan by the same figures.

Similarly the rest of the development can be found in less time than it takes to write out the explanation. The *rationale* of the methods generally comes with a thorough mastery of them. The teacher should see to it that the reasons *do* appear. When this solution is fully understood, the pupil may attack other problems with confidence. A cylinder may now be cut by a plane, and developed.

Next follows a cone similarly truncated. The cylinder is treated as though it were a prism of a large number of sides; and the cone is treated as if a pyramid. When the sides of the base are taken as small as a quarter of an inch (to a radius of one inch), the difference between the circumference of the circle and that of the inscribed polygon is quite inappreciable: about one-sixtieth of an inch.

It is not difficult to greatly extend these exercises, giving the intersections of one solid with another; but I doubt its utility beyond the intersections of cylinders and of prisms. Two examples of the former and one of the latter are all I would give before the systematic study of descriptive geometry, which offers the only proper basis for the study of intersections of surfaces, shades and shadows, and perspective.

Isometric drawing should be illustrated by two sheets, the first containing the projections of geometrical solids and the details of wood-work, partly from models, and partly from working drawings. The second sheet should contain the isometric projections of a piece of apparatus, or set of shelves, or similar plane-faced work, with isometrics of its details. Details are

<sup>1</sup> The teacher should explain and illustrate this bit of *geometrical drawing* just as it is needed.

usually drawn to a larger scale, that the essential features of joints, etc., may be clearly shown. The first isometric drawing should be a cube with an inscribed circle on each face. Give special attention to the method of getting points in the ellipses which result from the projection of these circles, so that the pupils may in future get the projections of such circles without aid.

Flat-tinting, or "washing-in" with dilute India-ink and a brush, should be practised till the pupil can get an even tint of any required depth of color. The sheet should in part represent mere mosaics; and in part a succession of ribs, blocks, and depressions, square or cylindrical, receiving shadows, and bearing different grades of shade.

A most excellent exercise in pure lining is to draw in pencil a sharp circumference of about three inches radius, using a horn center so as not to prick the paper. Divide it into any convenient *even* number of *equal* parts from sixteen to twenty-four, and then draw *smooth, even, jet-black, straight lines* from every point of division to every other point of division. Finally, rub out the original pencil line. The results if well done will be very satisfactory. Tho a purely rectilinear figure, it will suggest a large number of circles. I hope every teacher of instrumental drawing will give this exercise.

In laying out architectural work the teacher must not be too ambitious. College or engineering students have often found it necessary to study the drawing as outlined above, and they have often shown no more finish than these boys now show; and yet it is manifestly unwise to undertake the same grade of architectural work with these as would be done with them. Maturity and mathematics are great helps in abstract drawing.

Rest content with a study of moldings, of balusters, of pediments, of brick arches and skew-backs, of the main features of columns, capitals and cornices, and of girders and joice (in isometric). Two sheets of such work with elaborate borders will suffice.

As to free-hand work, it should follow, or rather accompany, instrumental work. As soon as the principles involved are

understood and illustrated by accurate instrumental work, they should be illustrated by free-hand work. Clearness, boldness, and precision should be aimed at, and the work should be done on a large scale. Brown paper may be used, and considerable erasing allowed. The principles involved in free-hand work are the same as in instrumental. In drawing from objects the original sketches should always be largely free-hand.

Some ornamental lettering, and study of borders, will close the drawing for the second year.

#### THE SHOP-WORK.

The shop-work of the second year is mainly in an entirely new field. Nothing could be more unlike than the forge and the bench, the anvil and the vise, fire and the cutting edges, iron and wood. In the forging shop, to which we now go, personal characteristics are more prominent than in the former shop. *Every thing* seems to depend on the student. No machine or tool does his work for him. *His* eyes, *his* hands, and *his* judgment are chiefly responsible for the results. It is for this reason that a bright boy soon discovers a wonderful relish for the work in spite of its occasional call for severe exercise, its abundant dirt, and its fervent heat.

The shop has twenty-two forges, each supplied with a power blast, a tank of water, an anvil, and a kit of forge and anvil tools. The forges are of a portable or special make placed in pairs back to back, with a common hood and up-take, and a nine-inch pipe leading, to the main exhaust pipe which connects directly with the large fan.<sup>1</sup> Each up-take has a tight-fitting damper, which should be closed when the fires are out; a single fire, or even several fires, may then be used without starting the fan, if the chimney has a fair draft. With the fan and all the fires in full blast, there should be no serious difficulty from smoke and gas in the shop. The hood shuts in three sides of the forge for the double purpose of confining the smoke and of keeping

---

<sup>1</sup> In the St. Louis School there is a Sturtevant fan with a delivery of 18" by 23" which was presented to the school by the inventor. It carries off the smoke most efficiently.



the radiant heat from adjacent workmen. Above the twee (tuyere) is a circular fire-pot six inches in diameter, admitting of a fire large enough for all the uses of the shop.

One forge rather larger than the rest, with larger fittings, serves for heavier occasional work. The anvils stand on oak blocks sunk in the clay floor and (with one exception) weigh about eighty-four pounds. The water tanks of cast iron hang by forged hooks upon the edges of the forge. The kit of tools comprises a machinist hammer weighing (with handle) one pound and three quarters; four pairs of tongs:  $\frac{1}{4}$ "',  $\frac{3}{8}$ "',  $\frac{1}{2}$ "' and  $\frac{3}{4}$ "'; a poker, a rake, a shovel, a sprinkler, an anvil, a chisel ("hardy"), a steel square, and one sledge to two forges. One leather apron belongs to each forge.

Fig. 68 is made from a photograph of the St. Louis forging shop, and shows many of the details of the shop.

The cost of a forge and one set of tools is about \$25.00, not including blast and fan. The cost for these two things is too dependent upon circumstances to be estimated.

The operations of the forging shop involve a personal knowledge of three things:—

1. How to heat the piece to be operated upon;
2. How to hold it; and
3. How to strike it.

In accordance with strict educational methods we analyze the operations, give opportunity to acquire the three kinds of knowledge, and teach the three arts separately.

I. HOW TO HEAT. The management of the fire so as to secure any desired degree of heat; to have one point of the piece hot and all others cool; to keep the piece under treatment clean; to save fuel; and to know just the degree of heat necessary for each operation—these are things slowly learned, but they must be learned well.

II. HOW TO HOLD. As a rule this is the work of the left hand. It involves an intimate acquaintance with hammer and anvil; a knowledge of the behavior of metals at different temperatures under the hammer; and a knowledge of what can, and what cannot, be done with metals through the agency of heat and pressure.

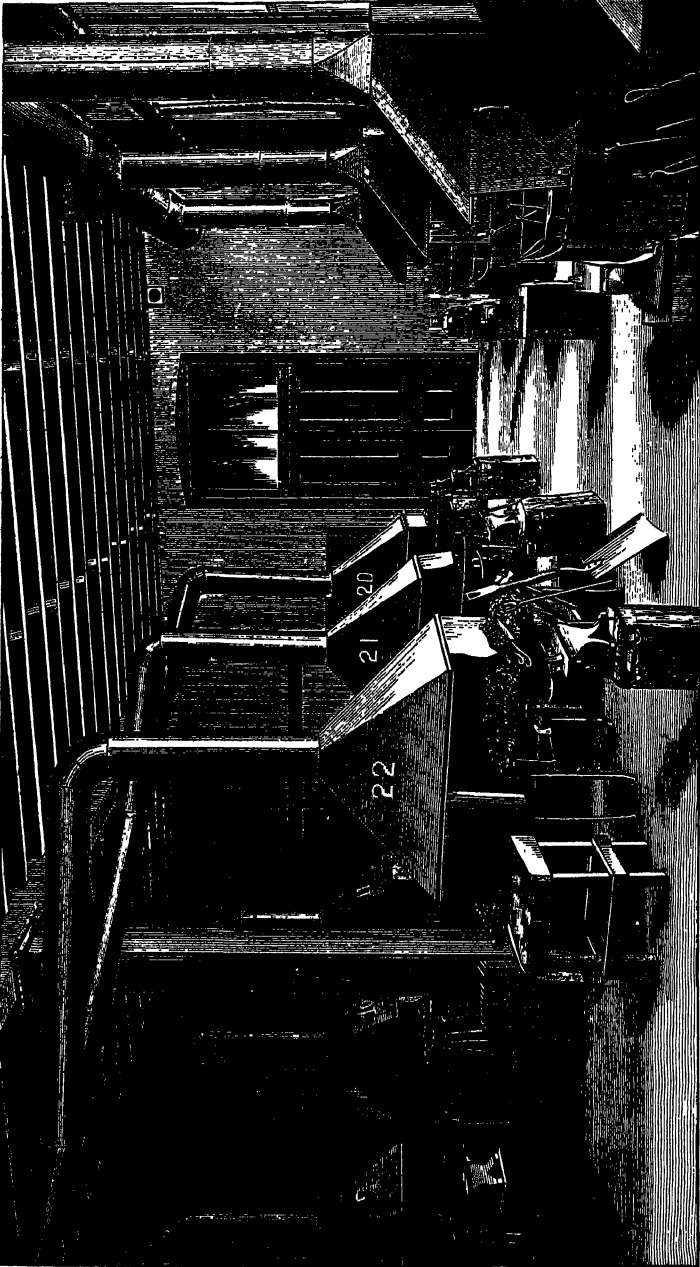

FIG. 68. THE FORGING SHOP.

This gives a very good idea of one-half of the shop. The forges on the right are angle, with heavy sheet-iron tanks for clay and bricks; eighteen of the twenty-two are portable, and are set in pairs under a double hood. The floor is chiefly of cinders and clay. The exhaust fan is in the 24-inch pipe in the left-hand corner of the shop.

III. HOW TO STRIKE. Here the right hand and arm, wrist, elbow, and shoulder, come into full play.<sup>1</sup> Strength and reliability are essential to force and accuracy. The pupil must learn how to grasp, how to swing, and how to deliver blows. He must know the particular tools to be used; when to strike heavy, when light; when rapidly, when deliberately.

Precepts, examples, and trials are all necessary, and the teacher must, to a certain extent, teach these arts separately.

The worker at the anvil has, so far as the matter of forging is concerned, but a few processes to learn, though the number of ways and degrees in which they may be combined in practical work may be countless. With special combinations the manual training school has little to do; it is chiefly concerned with the fundamental principles.

The processes may be classed as follows:—

1. DRAWING, or making a piece longer.<sup>2</sup> The effect of blows on the sides of a piece, thereby forcing out the ends, is similar to that of tension applied at the ends.

2. UPSETTING, or making a piece shorter by blows upon the ends. This is just the reverse of "drawing."

3. SHAPING, or changing the *figure* of a cross-section without changing its area. This operation combines Nos. 1 and 2.

4. BENDING, using various shapes,—round, square, and flat; the last is to be bent in two ways. This operation involves STRETCHING and COMPRESSING, and according to the quality of the metal requires a special heat. In all these exercises the student must learn to work rapidly when the iron is hot, and to stop the moment the temperature has fallen too far.

5. PUNCHING, CUTTING, and BREAKING. These operations depend on the nature of the material and on the degree of heat.

6. WELDING, uniting two pieces by forcing the fibers to intermingle at a high temperature. This requires a nice adjustment

---

<sup>1</sup> I am quite in favor of doing justice to the left hand and arm, and would encourage pupils to use either hand, but I would not delay the progress of the class on that account.

<sup>2</sup> The teacher who has studied strength and elasticity of materials will understand that heat lowers the elastic limit, and makes it comparatively easy to lengthen or shorten the fibers of metals in "*permanent set*" without injury.

of the heat in the two parts at the same instant, and their superposition with clean surfaces. Generally two people are necessary in making a weld, and each may use his hammer. The welding of two pieces should be preceded by the welding of the parts of a bent piece, where no helper is needed.

7. HARDENING and TEMPERING STEEL. There are endless varieties of temper for different grades of steel. A great deal may be learned from lectures and a judicious series of exercises.

We have found it exceedingly profitable to teach the two arts, of holding and striking, by means of a preliminary exercise in soft metal, generally lead, which is wrought cold. *Just* how to hold and how to strike depends upon the form to be produced, and it is of the utmost importance that that form be clearly in the mind of the young artist.

The teacher first gives drawings of the required piece, with all necessary dimensions. He next names the tools to be used and the order in which the steps are to be taken. (This *order* is much more important than it was in wood-work the first year.) He then *takes the steps himself*, calling attention at the same time to his manner of holding and of striking. His piece is compared with the drawings and should fairly embody the required dimensions. The teacher should always do his best work in the presence of the class.

One of the anvils should be so placed that one or two semi-circles of temporary seats may be ranged around, so that each pupil may see and hear all that is done and said.

In following the teacher's lead, the pupils have a clearly marked course before them, but it will be found that much deliberation will still be necessary. A hasty blow, or a wrong motion to the piece, results in malformation or serious injury. Hence the pupil must *think the matter out*, and strike only when his mind has correctly analyzed the problem, and foreseen the results.

This shows the advantage of cold lead over hot iron: with the one, the mind may take time to reason out the how and the where; with the other, he must "strike while the iron is hot," though with fatal indirection. If one stops to think, the iron cools, and then it breaks from being worked at a low tempera-

ture; or it must be reheated, at the expense of time, and a surface layer of material which may leave the piece scant. We have found that the use of lead has been economical in three ways: It saves time in the end; it saves material (the lead is melted over into new bars with little loss); and it secures more accurate workmanship, inasmuch as the exact form is better understood.

It frequently happens even in light work that a heavy hammer must be used. A heavy hammer moving slowly is a very different thing from a light hammer moving rapidly, even when they have the same momentum; one may tear the fiber while the other does not. This may be admirably illustrated by upsetting the hot end of a rod which is held in the hand. With a light hammer and a quick blow, the upset is all at the extreme end; with a heavier hammer and a slower blow, the upset is distributed for some distance; with a *very* heavy hammer and the same momentum, nothing may be accomplished. In a general way, our young workman must test this point and know when to call the aid of another student, either to swing the sledge or to hold while he wields the sledge himself. Two or even three strikers on one piece may at times work to advantage.

The following series of exercises has been adopted as serving the double purpose of bringing out the several processes, and of acquainting the pupils with the more usual standard forms. It should be borne in mind that many are to be wrought in lead to exact dimensions, and then in iron or steel (sometimes both) as closely as possible. The dimensions of the "stock," or raw material furnished the pupils, are given in each case.

**No. 1. (Fig. 69.) Bent ring.** The object is to get uniform curvature. The stock is  $\frac{3}{8}$ " round rod of a length equal to the circumference of a circle whose diameter is  $2\frac{3}{8}$ ".

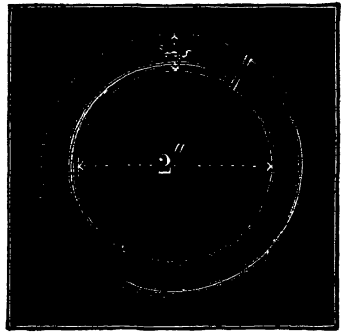

FIG. 69.

**No. 2. (Fig. 70.) Figure eight.** Stock,  $\frac{3}{8}$ " round rod. This is somewhat more difficult than the last.

**No. 3. (Fig. 71.) Ring handle.** Stock,  $\frac{3}{8}$ " round rod. These first exercises give practice in bending, and in realizing the *length* of bends. Tho very simple on paper, an attempt to produce them is certain to develop many new ideas.

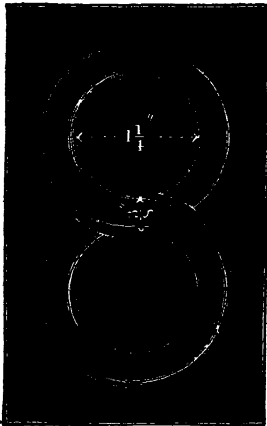

FIG. 70.

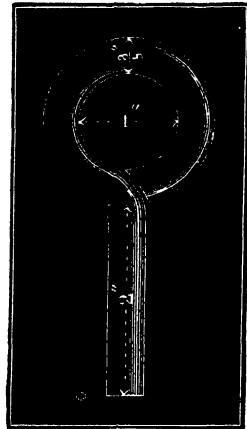

FIG. 71.

**No. 4. (Fig. 72.) Square piece with taper.** Stock,  $\frac{3}{8}$ " round. The finished No. 3 is straightened and used for this exercise. The body is reduced to a square prism, and the end to a pyramid. This is the first step in drawing out. The exercise should first be executed in lead, beginning with a short rectangular bar.



FIG. 72.

**No. 5. (Fig. 73.) Hasp and staple.** The stock for this hasp is exercise No. 4. One end is reduced to a cylinder and bent into the circular head. The other end is rounded, drawn out, and bent. The body of the shaft is then heated very

hot, the ends cooled by dipping in water, and then grasped by two pairs of tongs and twisted  $180^{\circ}$ . For the staple use  $\frac{1}{4}$ " round.

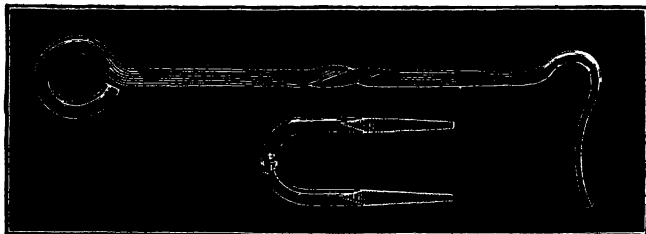

FIG. 73.

**No. 6. (Fig. 74.) Flat bend.** Stock,  $1'' \times \frac{1}{2}''$  bar,  $5\frac{3}{4}''$  long. The exterior is to be finished sharp and square, while the interior may be left rounded with a small fillet. The material is to be left sound. The exercise should first be executed in lead.

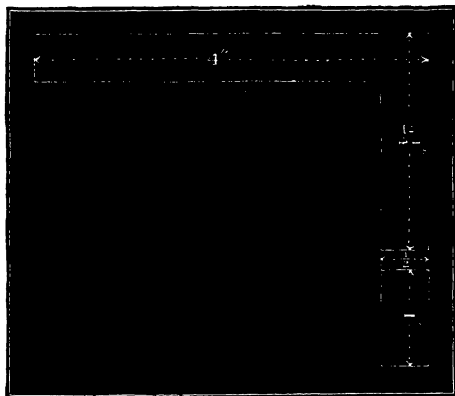

FIG. 74.

**No. 7. (Fig. 75.) Edge bend.** The stock is shown in the drawing. The inside corner is very hard to form and keep the material sound. One great object of this exercise is to teach the student the necessity of avoiding this operation when strength is to be preserved. It is much easier to do if the outer angle is left rounded; and, strange as it may appear, it will be stronger thus, tho deficient in breadth, than when

reduced to the exact shape of the drawing,—in consequence of the inevitable weakness of the inside corner. The exercise should be executed first in lead.

**No. 8. (Fig. 76.) Upset oval.** Stock,  $\frac{1}{2}$ " round, 5" long.

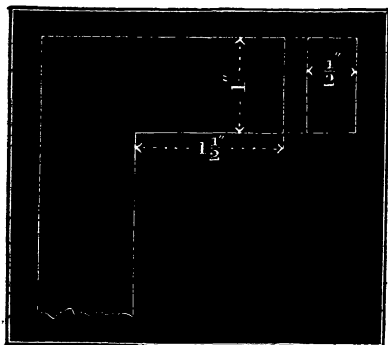

FIG. 75.

The first step is to increase the size of the piece in the center by "upsetting." Heat the center, cool the ends quickly, place the piece vertically on the anvil, and strike heavy, square blows on the end. The diameter at the center should be increased to about  $\frac{5}{8}$ ". The tapering ends require great delicacy of hammering because one cannot use the swages. Before

punching the small hole, the student should practise at punching a piece of plate or bar.

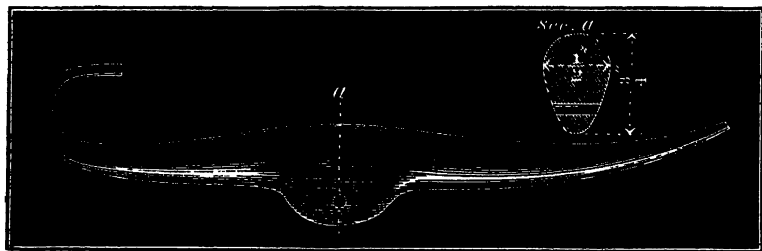

FIG. 76.

**No. 9. (Fig. 77.) Upset square.** Stock,  $\frac{3}{4}$ " round,  $6\frac{1}{2}$ " long. This exercise is an extension of the last, the amount of upsetting being greater. The production of straight cylinders, true with the axis of the square central part, is difficult. A preliminary exercise in lead is very instructive. Instead of one of the cylinders, it may be well to form a rectangular piece with an oblong section. The swage would then be used for one end, the flatter for the other.



**No. 10. (Fig. 78.) Fuller piece.** Stock,  $1'' \times \frac{1}{2}''$  bar, about  $6\frac{1}{2}'$  long. This should first be executed in lead. By no other means so well can one's judgment as to quantity of material and methods of manipulation be cultivated.

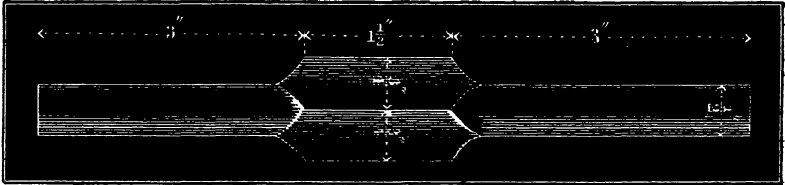

Fig. 77.

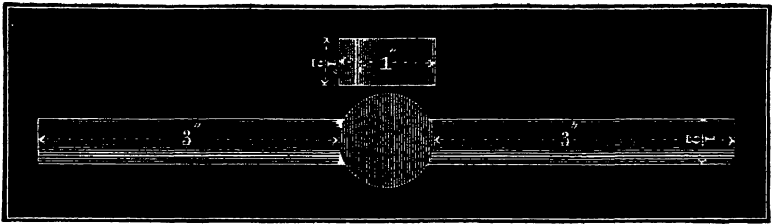

Fig. 78.

**No. 11. (Fig. 79.) Forged fork.** Stock,  $1'' \times \frac{1}{2}''$  bar. The vertical dimensions are omitted, it being impossible for an inexperienced person to hit them. The first operation is *punching*; the second, *splitting*; the third, *fullering*; the fourth, *drawing*; the fifth, *finishing*. The exercise is very difficult and should be preceded by a lead exercise. Students should be warned not to finish the small ends until the last thing, as they may otherwise be spoiled by burning. Later on, the student may attempt to construct this fork, by welding two pieces of round rod. When he has fairly tried the two methods, he may have an opinion as to their respective advantages.

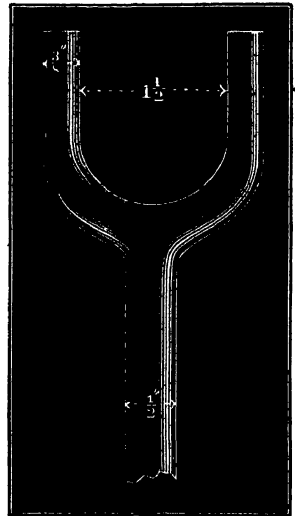

Fig. 79.

**No. 12. (Fig. 80.) Hook hanger.** Stock,  $1'' \times \frac{1}{2}''$  bar. Execute this in lead to begin with. The *length* of the hook will be a surprise. Flatten and punch the plate end before bending the hook. The exercise is not as difficult as it appears at first.

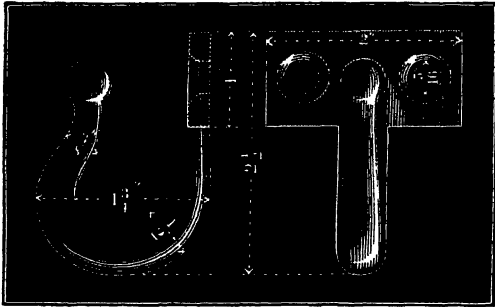

FIG. 80.

**No. 13. (Fig. 81.) Bent brace.** Stock,  $1'' \times \frac{1}{2}''$  bar. This exercise combines the features of Nos. 10 and 12. If a particular length is desired, the body of the brace should be left slightly in excess and then drawn as required for the finishing touch. It need not be done in lead.

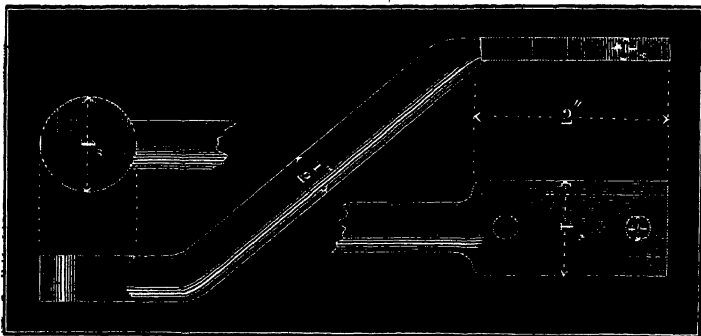

FIG. 81.

**No. 14. (Fig. 82.) Plate riveting.** The stock consists of two pieces of boiler-plate  $5'' \times 10''$  with six equi-distant holes drilled in each. (This drilling should be carefully done by machine-shop students.) The last *three* rivets, at least, should

be well put in, and the heads should be smoothly coned without indenting the plates.

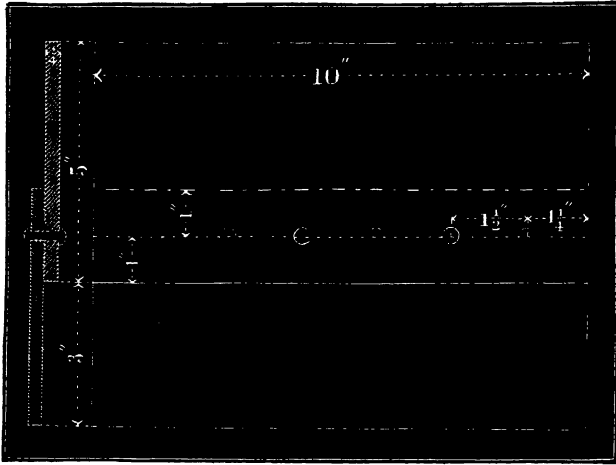

FIG. 82.

**No. 15. (Fig. 83.) Log chain welding.** Stock,  $\frac{3}{8}$ " round rods, about 9" long. This is the first attempt at welding, and a great many points are to be carefully noted. Above all, the fire must be kept clean and in good condition. The reader is

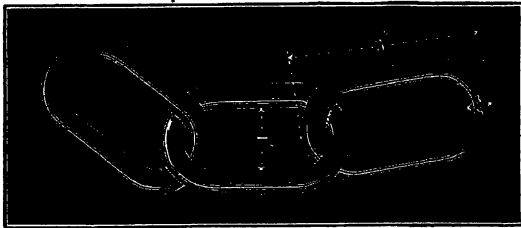

FIG. 83.

referred to the lecture on "The Care of the Fire," which comes a few pages farther on. The operation of "scarfing" prepares the two ends which are to be united so as to have a single surface of contact, which should be nearly a plane oblique to the axes of the ends. A shoulder rarely welds, and hence is a source of weakness. Several attempts may be necessary to

make the first weld. The third link should be well done. The welding of the two ends of one piece is much easier than the welding of two separate pieces.

**No. 16. (Fig. 84.) Ribbed handle.** Stock, a  $\frac{3}{8}$ " rod, about 30" long. The rod is bent back and forth hot, till it is fourfold,

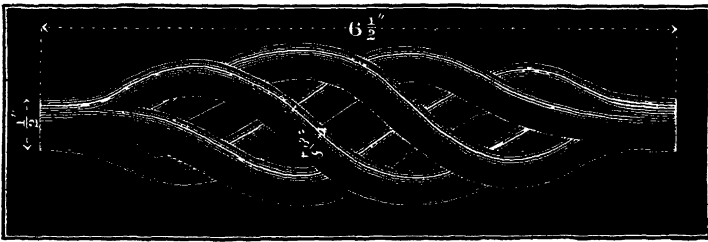

FIG. 84.

the cross-section being four tangent circles whose centers are at the vertices of a square; then the ends are welded, embracing the parts uniformly. The bundle is heated to a red heat, and the rods bent out by upsetting the bundle. Then again at a proper heat, while one end is held in a vise, the other end is turned  $270^\circ$ .

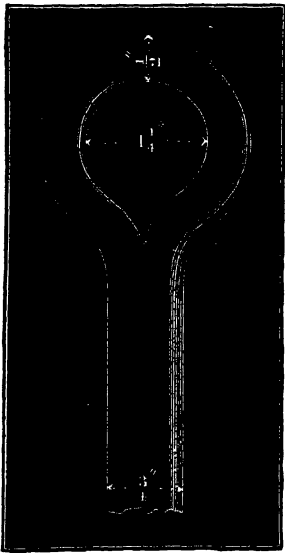

FIG. 85.

**No. 17. (Fig. 85.) Welded eye.** Stock,  $\frac{3}{8}$ " round rod. As this is preliminary to No. 18, the free end should be long enough for the complete hook. About two inches of the end is drawn out to nearly four inches, bent round, and welded to the shoulder on the body of the rod. The danger of burning is so great that one should aim at  $\frac{5}{8}$ " in thickness instead of  $\frac{1}{2}$ " as the drawing shows. The exercise is not an easy one.

**No. 18. (Fig. 86.) Chain hook.** The stock is furnished by No. 17. The shaft just below the eye is to be slightly reduced. The drawing shows the point of the hook a

little too long. For the sake of learning the length of the portion required for the hook, as well as the effect of bending, it is well to execute first in lead.

**No. 19.** The welded angle. Stock, two 1"  $\times$   $\frac{1}{2}$ " bars. This exercise shows a second way of making the piece shown in Fig. 75, No. 7. The scarfing of the two ends should give them very oblique slopes without shoulders. It would be well to

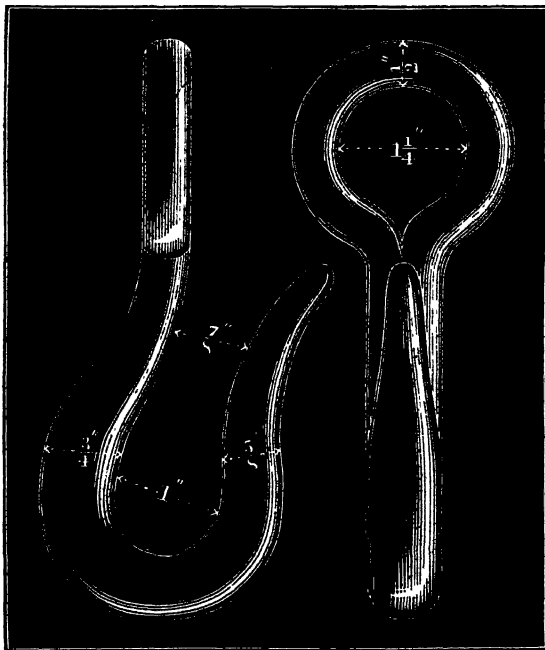

FIG. 86.

practice the scarfing on two pieces of lead. With a good weld, this makes a much stronger piece than the bent angle. The teacher should test the strength of Nos. 7 and 19 in the presence of his class.

**No. 20.** A straight weld. Stock, two pieces of rod of equal size. When finished, the piece should be of nearly uniform size and should show no weld marks. This exercise, like the last, requires two people, and the difficulty of bringing the two pieces to the anvil at a proper heat and at the same

time is one which must be met to be appreciated. As welds are more or less imperfect, it may be well to leave the cross-section a little large at the welded point.

**Nos. 21 and 22. Bolt heads.** There are two ways of making a bolt by hand, and this exercise should be double. One way is to use a square rod larger than the body of the required bolt, draw out for the body, and upset for the head. That is one exercise. The other way is to use stock of the size required for the bolt, cut off a short piece, bend it into the form of a ring round one end (which should be slightly upset), and then weld and form the head. The second way is by far the most difficult. It is exceedingly hard to persuade the head to rest symmetrically on the shaft of the bolt.

**No. 23. (Fig. 87.) Crank arm.** Stock, 1"  $\times$  1" bar. The "points" of this exercise are good shoulders to the circular ends, and a uniform taper to the sides of the body of the piece.

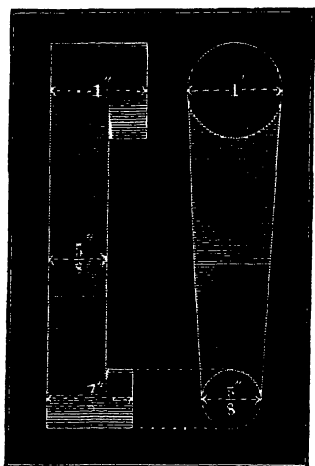

FIG. 87.

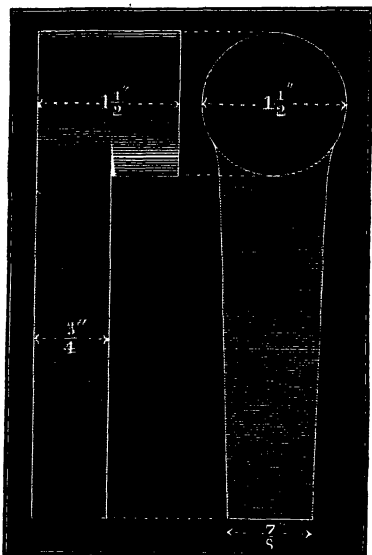

FIG. 88.

**No. 24. (Fig. 88.) Heavy crank arm.** Stock, 1 1/2"  $\times$  1" bar. This is similar to the last, but the work is much heavier. The heavy sledges come in well on an exercise like this; two or three men may well work on one piece.

**No. 25. (Fig. 89.)** Blacksmith's tongs. Stock, 1" × 1" bars, about 6" long. The exact shape of these parts should first be produced in lead, starting with stock 1" × 1" × 6". It

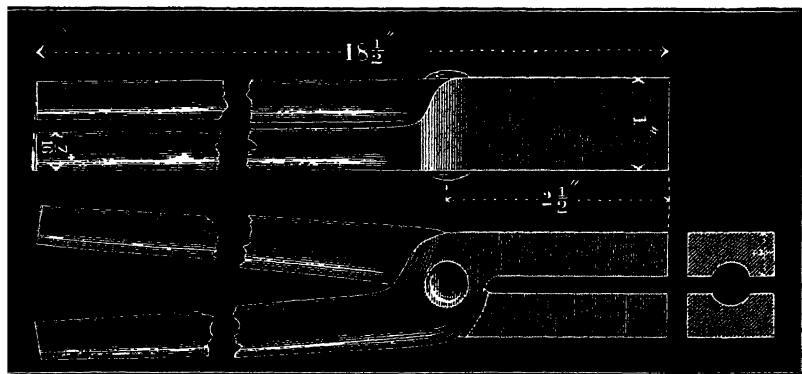

FIG. 89.

is only when every detail of form, holding, and striking is clearly in the mind that it is economy to start on the iron. The required width of the jaw-opening may vary with the demands of the forges. The long handles may be welded on before the jaws are finished. Each class should leave the forges well furnished with tools for the next year's class. Good tongs are evidence of good workmen.

**No. 26. (Fig. 90.)** The dog. Stock, 1" round, about 4" long. The hole is first punched, and then enlarged by splitting, and working over a mandrel.

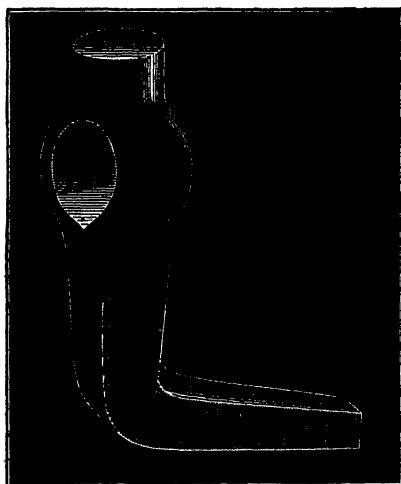

FIG. 90.

This "dog" is to be subsequently finished in the machine-shop by the maker.

**No. 27. (Fig. 91.) Cold chisel.** Stock,  $\frac{1}{8}$ " octagonal tool-steel. In forging steel, great care must be taken not to burn the piece. Burnt steel is worthless. This exercise is first a uniform draw to an edge. The operation of TEMPERING which is to follow should have many preliminary illustrations and exercises. Every student should temper his chisel, even if he has to temper it several times in order to get it right.

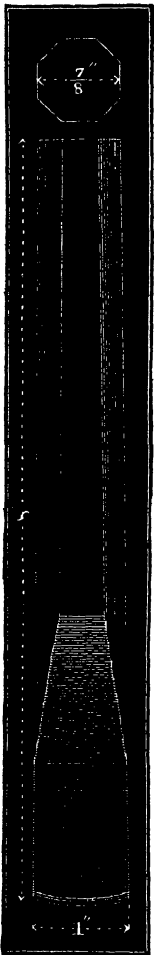

FIG. 91.

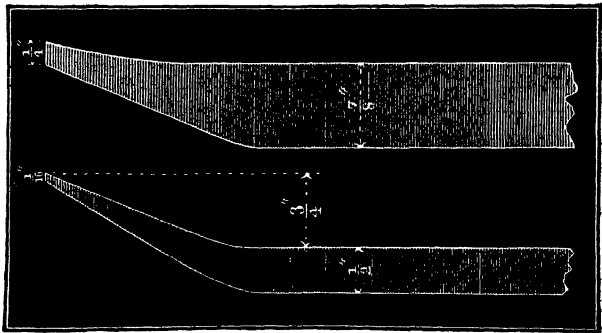

FIG. 92.

**No. 28. (Fig. 92.) Threading tool.** Stock,  $\frac{1}{8}$ "  $\times$   $\frac{1}{2}$ " tool-steel. This tool, and the five which follow, are for the student's own use next year in the machine-shop. They furnish good exercises in forging and tempering steel, as well as meet the demand for tools.

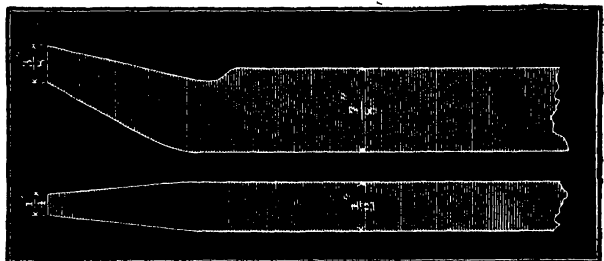

FIG. 93.

**No. 29. (Fig. 93.) Round-nose tool.** Stock,  $\frac{1}{8}$ "  $\times$   $\frac{1}{2}$ " tool-steel. Before this tool is used in the lathe the working end



is to be ground to a semicircular outline; it should, however, leave the anvil with square corners.

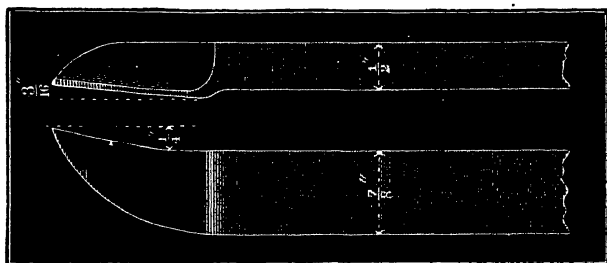

FIG. 94.

**No. 30.** (*Fig. 94.*) Side tool. Stock, same as No. 29. First execute in lead, for the sake of getting exact dimensions.

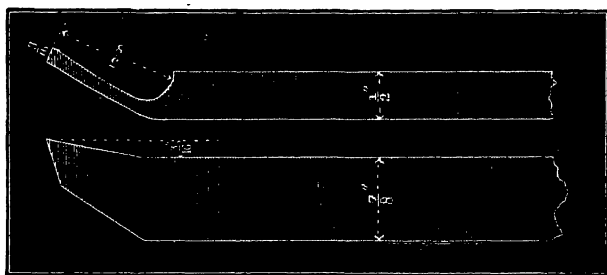

FIG. 95.

**No. 31.** (*Fig. 95.*) Parting tool. Stock, same as the last. First execute in lead.

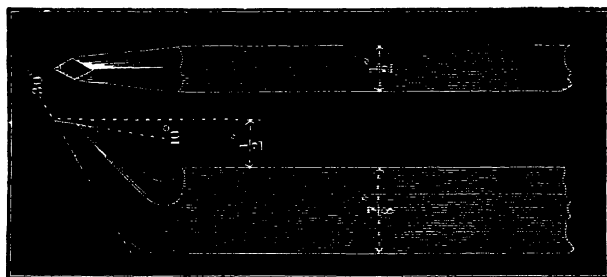

FIG. 96.

**No. 32.** (*Fig. 96.*) Diamond point. Stock, the same as the last. First execute in lead. The exact shape is not easy to get from a uniform bar.

**No. 33. (Fig. 97.)** Inside tool. Stock, the same as for No. 32. All these steel tools are to be tempered.

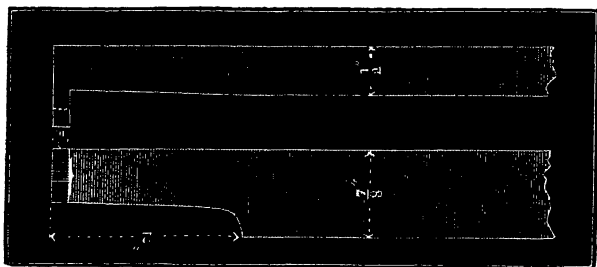

FIG. 97.

**No. 34. (Fig. 98.)** The hardy. Stock,  $1\frac{1}{4}'' \times 1\frac{1}{4}''$  bar steel. This is an anvil tool and should fit the anvil.

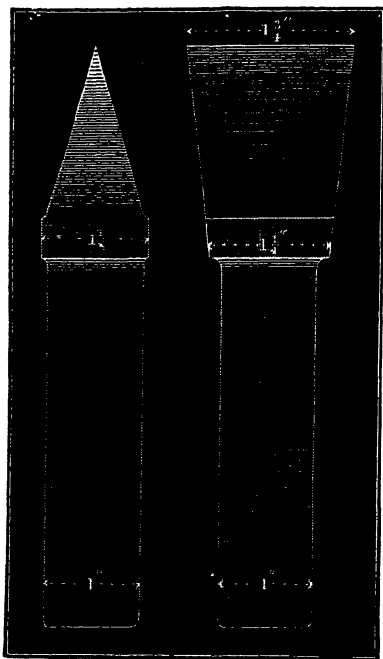

FIG. 98.

**No. 35. (Fig. 99.)** The set-hammer. Stock,  $1\frac{1}{4}'' \times 1\frac{1}{4}''$

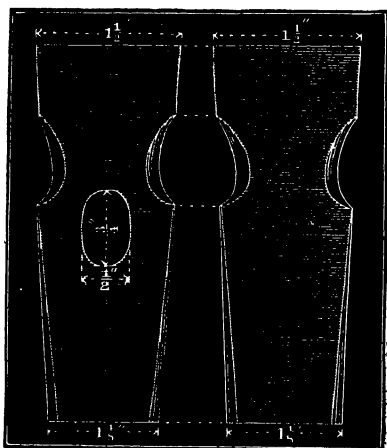

FIG. 99.

bar steel. The punching and forming the large hole in steel that can not be safely heated beyond a certain point, is a difficult task for a learner.

**No. 36. (Fig. 100.)** The flatter. Stock,  $1\frac{1}{2}$ "  $\times$   $1\frac{1}{2}$ " bar steel. The face of the tool is 2' square. The whole job is a little heavier than the last.

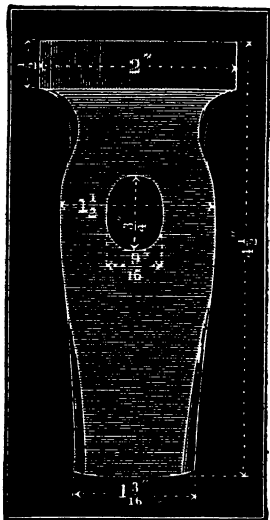

Fig. 100.

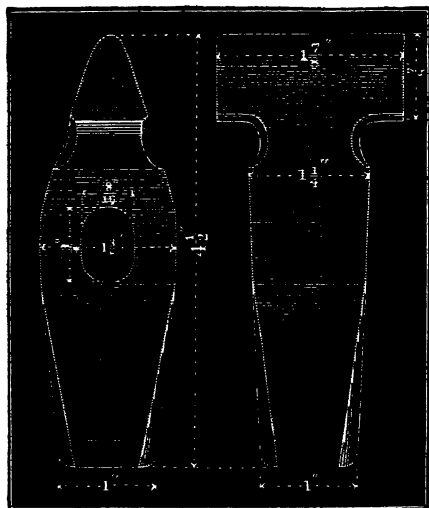

Fig. 101.

**No. 37. (Fig. 101.)** The fuller. Stock,  $1\frac{1}{4}$ "  $\times$   $1\frac{1}{4}$ " bar steel. This exercise is not unlike No. 35 in many respects and may be made to take its place according to the demands of the shop.

**No. 38. (Fig. 102.)** The bottom swage. Stock, 2"  $\times$  1" bar steel. This is the heaviest work in the shop and may very properly end the series of exercises. The shank calls for heavy forging.

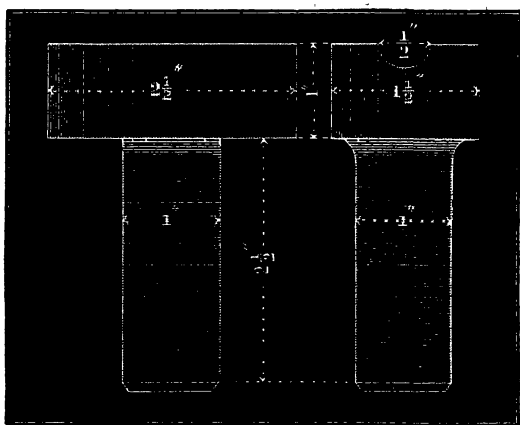

Fig. 102.

The groove is to be accurately formed by a steel templet.

The last five exercises furnish tools for the forging-shop itself. It is obvious that one finished piece may very properly serve as the stock for another slightly smaller. It is obvious also that for a difficult process, in which every pupil is likely to fail for the first attempt, a piece of scrap or a small trial piece may be used. For instance, no one succeeds the first time in making a welded bolt-head from a piece of round rod; some never succeed.

In difficult processes, quality should be aimed at before quantity. In making a weld, for instance, one must learn the conditions of a good weld before any attention can be paid to dimensions. It thus appears that what I have put down as one exercise may in reality combine several.

The process of tempering is a very delicate one, and requires explicit directions and full illustrations. The teacher should produce in the presence of his class a series of tempers with different colors and should explain and illustrate the peculiar advantages and disadvantages of each.

At the end of the series of regular exercises in a shop, one or two new exercises should be given with a view to develop the ingenuity and inventive talent of the pupils. The drawings should show the finished work, and no clew should be given by the teacher as to how the work is to be done. Every boy should be required to think out and put down in writing and illustrate by drawings: (1) the order of the steps, (2) the tools to be used, (3) the methods of work. These should be carefully examined, criticised, and compared. Good points ought to be fully recognized and commended. The teacher should then select or arrange the best course, and let the project be executed.

#### THE MANAGEMENT OF THE FIRE.

I have thought it best to give under this head an almost verbatim extract from the instructions given by our accomplished teacher of forging, Mr. Charles E. Jones.

Imagine him at his forge in the center of a semicircle of interested boys, no one of whom has yet had an iron in the fire.

As the instruction begins and goes on imagine him "suing

the action to the word " with a force and fitness which Hamlet never dreamed of. In fact the eager eyes of the boys follow what he *does* as their ears drink in what he says. In the course of his short lecture he shows them *just how to do it*, as well as "how not to do it." Now listen and watch him!

" Before lighting the fire I wish to call your attention to the blast orifice — also to the blast gate, and to explain how to use it. I shall also give you a few hints upon the care and management of the fire.

"In the first place notice the position of 'the blast opening relative to the forge, for it is immediately over the blast opening that the fire is hottest; it is at this point we wish to place the work to be heated, that is, some three or four inches above and immediately over the blast opening."

[Here Mr. Jones places the kindling and coals, and lights the fire. He turns on a proper blast and soon has a mass of glowing coals.] "It will be readily seen that to heat the work we must have some fuel between the work and the jet of air that is urging the fire. Hence we must not put the iron too low, not only because the point I have named is probably the hottest part of the fire, and consequently will heat the work the quickest, but because, as the fuel burns away, the cinder, in a liquid state, is gradually settling to the bottom of the shallow pit in which the fire is built; and if the work is put too low in the fire, it becomes coated with this semi-vitreous mass which when worked on the anvil is driven into the surface of the iron. When this is cooled it contracts and scales off, leaving the surface of the iron deeply pitted with the appearance of being rust-eaten.

"The fire should be kept as small as will possibly heat the work in hand; in our case say from four to six inches in diameter. This is accomplished partly by packing the coal as hard as possible around the desired size of fire, and partly by frequently sprinkling around the fire with water whenever it shows signs of spreading. This packing of the coals around the fire also prevents in a measure a wide disturbance of the fire whenever the work is thrust into it. Some disturbance cannot be avoided, consequently the fire should always be repaired

when this happens, care being taken not to throw in the green coal first, but those portions that are the hottest; this is important, particularly as the work approaches a high temperature, a welding heat for instance. At such a time the thrusting in of cold fuel cools the fire and sets back the heat. In these forges the size of the fire is in part regulated by the ring of fire bricks which forms a sort of fire-pot two or three inches deep. In no case must these bricks be loosened or disturbed.

“In this connection the blast also plays an important part. Greater force should be given towards the end of the heating, except in case of small work, where a uniform amount of blast is given, graded as nicely as possible to the size of the fire. If too much blast is given and the fire is nice and clean, the burning coals are scattered over the hearth; in fact, this frequently happens, particularly just after the fire has been cleaned of the cinder.

“Sufficient coal should always be kept on the forge to keep up the embankment, or backing, previously spoken of, the coal to replenish the fire being drawn up from the edges nearest the fire with the rake or shovel.

“I should also explain that, as the blower furnishes a uniform pressure of blast, the way to control the blast to suit the size of fire is by giving the blast-gate a greater or less opening: this, after a few hours' practice, is generally pretty well understood. To keep the fire reasonably small is much more difficult. When, told to sprinkle it you will often overdo it to such an extent as to put out the fire at the bottom, leaving only a layer of live coals on the surface; you will then be surprised that your iron does not heat, but it will be no longer a mystery when the surface coals are removed and it is seen that the work lies imbedded in damp ashes only. I must here explain that the only means we have of ascertaining when the work is of the proper heat, is by withdrawing it from the fire and looking at it, quickly replacing it if not of the proper heat. When it is withdrawn, you should notice if it is being heated at the proper place; if it is not, then push farther in, or not so far, as the case may be, for it frequently happens that the cinder obstructs or deflects the blast in such a manner that the hottest

part of the fire is not where we naturally look for it, viz. immediately over the tweer opening. You must therefore keep your eyes open and your wits about you all the while.

“I shall teach you the several degrees of heat we shall need, and how to recognize them as our exercises proceed.

“From what I have said and from what you would naturally expect, we shall look for the cinder in the bottom of the fire-pot, the hottest coals next above, and the half incandescent coals on the surface. These positions suggest the method of *cleaning the fire*. By cleaning the fire I mean removing the cinder which is a mass of ashes and incombustible material always found more or less in coal. This refuse melts partially and cakes into layers which must be removed every hour or two so as to leave the fire clean. When done at all the cleaning should be thoroughly done, as follows:—

“First rake away the half incandescent coal into a pile by itself. Next, draw the fully glowing incandescent coals into a second pile just beyond the edge of the fire-pot. Now with the shovel quickly cut out the layer of cinder and throw it on the cinder pile under the forge. Then carefully draw back the live coals into the fire-pot, keeping them together as much as possible. Next, draw over and around them the half burning coals and put on the blast. Green coals may now be packed around and sprinkled. In a moment you have a clean and hot fire.”

The reader must bear in mind that while thus describing the process Mr. Jones is actually going through it in a skillful and efficient manner. But not that alone: the next step is for every boy to go to his individual forge and go through the same operations himself under the teacher's eye. A single glance tells the expert whether his instructions and example are being followed or not, and a few extra words and motions suffice to set right a boy who has forgotten or who has not understood. No boy fails to be interested and attentive, though some fail to comprehend the first time.

Fullness of explanation and illustration is not peculiar to this exercise; it is characteristic of every exercise. *Ab uno disce omnes.*

## SOLDERING AND BRAZING.

As already explained the time to be spent in molding and pattern-making may properly be one-fourth of the shop-time of the second year, a maximum of one hundred hours, making no allowance for certain exercises in soldering, which may receive more or less attention according to the facilities for that work. In the St. Louis school we have facilities for but four simultaneous workmen at soldering, and only miscellaneous work in that direction has been done. The *principles* involved can be taught in two or three lessons, but considerable practice would be necessary to their full comprehension. The construction of an elbow to a pipe, or an oil-can or coffee-pot suffices to test both one's knowledge of hard-soldering, and his command of the subject of development of surfaces in drawing. Brazing may be taught in a lesson or two in the forging-shop. A single exercise in brazing two pieces of iron together is exceedingly instructive.

The three divisions of a class may very naturally take up pattern-making and molding in succession.

PATTERN-MAKING AND MOLDING.<sup>1</sup>

Differing from the practice in many lines of work, it is not usually the case that a pattern-maker is furnished with drawings which he may exactly follow. In other lines one is given a drawing of the finished piece, and he is expected to follow it closely; in the case of pattern-making, the pattern must in the majority of instances have a shape differing from that shown in the drawing. This is chiefly because of the requirements and methods of the foundry, since it is there that the patterns are used. For these reasons a pattern-maker, in addition to skill in the use of his special tools and ability to read drawings, must be able to make the modified drawings required for his work; and to do this intelligently he must understand the methods of the foundry.

---

<sup>1</sup> What is said under the head of Pattern-Making and Molding is largely the work of Mr. Charles F. White, the Superintendent of Shop-work in the St. Louis Manual Training School.



Therefore in teaching it is best that some foundry-work precede pattern-making. Unless this is done the student is obliged to do a great deal of work which he does not understand the reasons for — a practice contrary to the spirit of a manual training school. It may be remarked that, very properly, students wish to use their own patterns in the foundry and to prove them by trial. A short time is sufficient for this, so that it is best to divide the foundry-work, giving the larger share before the course in pattern-making.

We therefore begin with the

### *Foundry-Work.*

As patterns must be made with constant reference to their use in molding (that is the forming of molds), so molds must be made with constant reference to their use as receptacles, capable of receiving and retaining the liquid poured into them. Each of the metals used in foundry-work has characteristics of its own, needing special treatment.

Molds for most work are made of moist sand. Into these is usually poured a molten metal at high temperature. There results a sudden and rapid generation of steam, hydrogen, and other gases. These gases must be permitted to escape readily or the resulting pressure will force the metal from the mold, which mishap is called "blowing." A mold must possess sufficient strength and firmness to resist the shocks of handling and retain shape against the flow and pressure of the liquid; moisture and close compact or ramming secure this. On the other hand, porosity for the escape of gases is equally needful; dryness and light compact secure this. Excess of moisture causes excessive gas production, calling for extra porosity. Judgment in properly balancing these opposing conditions is an essential part of the foundry-man's skill.

Sand of the quality known as molding-sand possesses in a large degree the desirable elements of porosity and of cohesion when moderately moist.

The receptacle which holds both pattern and sand is called the "*flask*." In its simplest form a flask may be described as a pair of boxes of similar shape and size, but without top or bot-

tom. These boxes are prevented from separating horizontally by suitable pins, which however permit ready separation vertically. Two flat boards as wide as the flask complete the apparatus. The lower part of the flask is called the "*drag*;" the upper part is called the "*cope*." The drag rests on the bottom-board. The other board, called the *mold-board*, is used at an earlier stage and is laid aside.

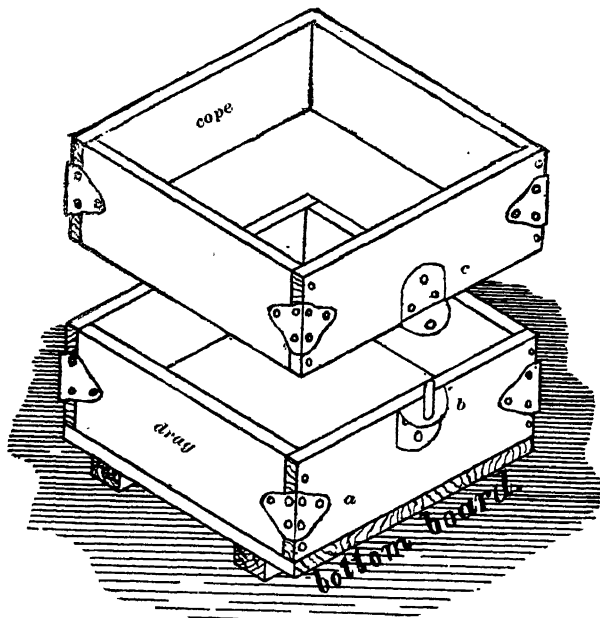

FIG. 103. A SIMPLE FLASK.

Fig. 103 shows the cope, drag, and the bottom-board. The small pieces of metal shown at *a*, *b*, and *c* are of malleable iron. They may be readily found in the market.

Flasks are made either of wood or iron, and are of almost as many shapes and proportions as there are forms to be molded. As a rule the drag is seldom disturbed after the pattern has been removed from the sand (drawn). The cope on the contrary must usually be moved, and hence the sand it contains must receive its support from the sides instead of from underneath. As a consequence, all copes of large area compared with

their depth must contain partition bars or ribs, numerous enough to sustain the sand. These bars must be shaped so as to approach without touching the pattern, and have beveled edges next the pattern to permit uniform ramming. Besides these bars, pieces of wood ("soldiers"), L shaped pieces of iron ("gaggers"), spikes, nails, and brads are used to assist in holding the sand in place. The inside of the cope, the bars, the ends of the soldiers, gaggers, etc., are usually clay-washed to make the sand adhere better.

The tools needed for a school outfit may be limited to the following:—

A small shovel.

A 12-inch brass wire sieve or riddle  $\frac{1}{8}$ -inch mesh.

A molder's trowel, 1"  $\times$  4".

A  $\frac{1}{4}$ -inch lifter.

A draw-spike,  $\frac{1}{4}$ " diameter by 6" long (see Fig. 104).

A large draw-spike,  $\frac{3}{8}$ " diameter by 8" long.



FIG. 104.



FIG. 105.



FIG. 106.

These draw-spoons should be made of round tool-steel drawn to a long, square point.

A vent-wire (Fig. 105) consisting of a stout knitting-needle six or eight inches long inserted in an awl handle.

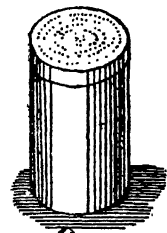

FIG. 107.

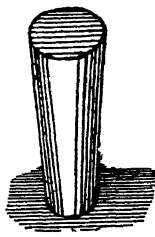

FIG. 108.

A couple of rammers (Fig. 106), one  $1\frac{1}{2}$  inches in diameter, the other 3 inches.

A half-pint tin can (Fig. 107) with perforated top for sprinkling parting-sand.

The above are needed by each pupil.

A six-quart sprinkling-can will suffice for four or five pupils. Similarly, a six-quart milk-pail (with strainer removed from the spout) will be needed if plaster be used to fill the molds.

Several conical wooden plugs (Fig. 108), a straight edge, a

small sponge, and a piece of tin two or three inches square bent as shown in Fig. 109 will be needed by each pupil as a gate-cutter.

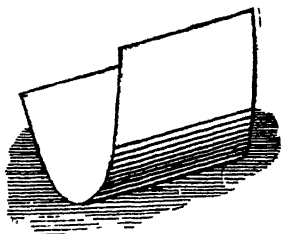

FIG. 109.

Parting-sand may be any fine powder which has very little cohesion, whether wet or dry. A coating of such sand between two layers of molding sand will permit the latter to separate (part) readily. A mixture of burned sand and oxide of iron obtained from the "tumbling-box" of a foundry is much used for parting-sand.

The large number of tools used by practical molders in repairing and finishing molds are not necessary to our work, and are hence omitted.

The molding-benches should be trough-shaped, not less than 12 inches deep by 20 inches wide at the top. A section of a double bench is shown in Fig. 110. The ledges in the troughs are continuous; they support cross-sticks and boards. The benches should be strongly built and in rows allowing at least *five feet of length* to each pupil. It is well to allow the backs and partitions to come up high enough to give places for hanging the small tools, and to keep sand from being thrown into neighboring benches in the action of shoveling or ramming.

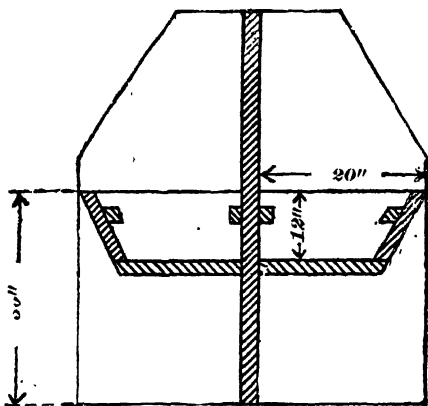

FIG. 110. A MOLDING-BENCH.

### *Cores and Core-making.*

In many cast forms it is necessary to produce holes or interior cavities. This is done by placing in the mold something which shall occupy the space which the liquid is not to fill. This

something must be removable after the cast is made, and there must be at least one opening for the removal. That which is so placed in the mold is called a "core." The meaning of the word is also extended so as to include additions to the mold *outside* the space to be filled by the liquid where the core is to be supported, or where an additional cavity is required in order to make a small projection to the main body of the casting. Those exterior parts of the mold which are to be filled by the cores or core-ends are called "core-prints."

Fig. 111 gives a vertical section of a mold ready for pouring. The parts of the pattern have been "drawn;" a central core *c*

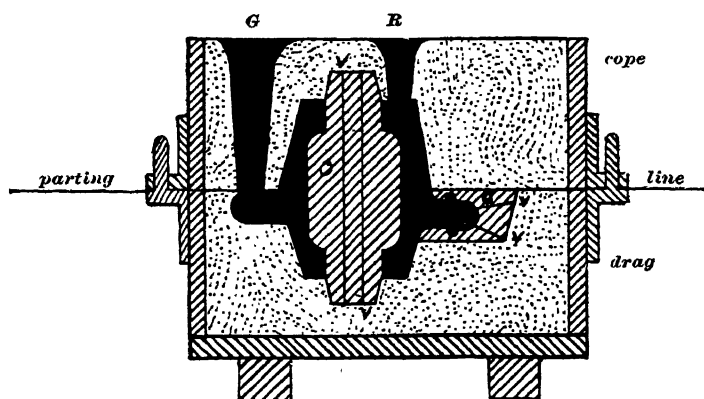

FIG. 111. SECTION OF A FLASK, MOLD, CORES, ETC.

is shown extending at top and bottom into the core-prints made for it; there is also an external core, *c*, having a cavity in itself which is to contain a sort of horn to the main casting. If the pattern of the horn had been put on the main pattern it would have been impossible to get the pattern out of the mold, but by the use of the core it becomes easy. The cope, drag, and bottom-board are shown in position; the plugs have been drawn from the pouring-gate *G*, and the riser *R*, and fine wire holes have been made to the points *v, v* to allow the gases to escape.

Cores are made of a mixture of sand and some adhesive matter. Usually a little flour is mixed with the core-sand.

This when moistened forms paste, and when dry or baked makes a firm block. Powdered rosin when heated in the baking will also fasten the sand. Cores must be porous, and hence they are usually made of a coarser sand than the regular mold. A mixture of half molding and half river sand is suitable for most work. If melted metal is to be poured into the mold the cores must be well baked and provided with passages (vents) for the escape of gas, leading out at the ends. If plaster is used venting is not necessary and cores need be baked only when they are of weak or delicate shape. Most shapes require internal wires or rods to insure strength, particularly before baking.

Cores are made by ramming the mixture above described into boxes which internally have the shapes wanted, and are called "core-boxes." These will be described later. The sand should not be so moist as to cause sticking to the sides of the box. If it can be easily passed through a  $\frac{1}{8}$ " sieve it will not be too moist. In ramming the cores use a small rammer, preferably an iron rod, keeping an excess of sand in the box and avoiding the formation of layers, which are always weak. Strengthening wires are to be placed in the boxes and the sand rammed around them. Until dried they should be handled as little as possible and be carried on small iron or tin plates.

In ordinary foundry practice, cores are all prepared by a core-maker, the molder having nothing to do with their design or construction. In school-work, however, it is best to have the cores prepared by the pupils themselves. This being done the next step is

### *Molding.*

We will follow the steps of molding the form shown in Fig. 111, assuming the pattern to be in two parts divided at the parting-line. The first completed step is shown in Fig. 112.

The mold-board was laid on the cross-sticks and the drag placed upon it bottom up. The lower portion of the pattern was then laid on the mold-board. The molding-sand is now sifted into the drag and rammed around the pattern, care being taken to have plenty of sand, to ram uniformly, and to avoid

layers. When somewhat more than full, the upper surface is scraped off with a straight edge, and the bottom-board laid on.

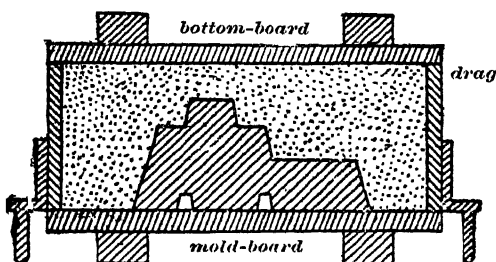

FIG. 112. LOWER HALF OF PATTERN IN DRAG.

Now comes the second step. The whole is carefully turned over and the mold-board is laid aside. The upper part of the pattern is now laid in place, guided by the little pins, and the cope is put on, guided by its plates, over the pins on the drag. A thin layer of parting-sand is dusted over the whole. A *runner* plug which molds a passage for pouring is set up *near* the pattern, and the sand is filled in and rammed, a *riser* plug

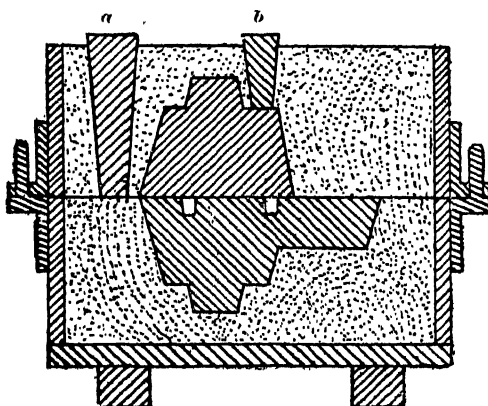

FIG. 113. PATTERNS IN POSITION IN THE SAND.

being put on the highest part of the pattern but not on the core-print. When the packing is finished, the appearance will be as in Fig. 113, which shows step No. 2 completed. *a* is the *runner*, and *b* is the *riser*.

The runner and riser are now drawn out; the cope is gently lifted off, turned over, and laid on the mold-board. A draw-spike is driven into the pattern in the drag, and the pattern is loosened by gentle raps on the spike as it is held by the left hand. The pattern is then lifted out of the mold, technically *drawn*, by the spike. A gate is now cut from the lower end of the runner to the mold, using a gate-cutter (Fig. 109). The pattern in the cope is now treated in the same way, and drawn. The cores are next placed in the mold, and the cope being replaced the liquid is poured in, filling the mold as in Fig. 111.

If molds are poured with plaster it will be found necessary to have the runners, gates, and risers of ample size, as after the mold is filled the shrinkage must be supplied through the riser. The plaster may be kept from setting by gently churning a rod up and down in the riser.

In preparing the plaster for pouring, use three parts of water to two parts of plaster, and stir well while the plaster is added. When about like cream in consistency, pour rapidly into the mold. Small metal castings can be taken from the molds in a few minutes. Plaster castings can be taken out with care in fifteen to thirty minutes, according to the state of the plaster when poured, the longer time being needed for plaster poured thin. Partly-set plaster must *never* be mixed with fresh plaster. Mix anew every time.

Cores in iron castings have the paste material so burned as to be friable and come out easily. With lead and light alloys cores are hard to get out, being simply hard-baked not scorched. With wet plaster the cores are so softened that they come out easily, though sometimes stout crooked wires must be left. Plaster castings may be cleansed by washing, and when dry by a stiff brush.

In the example given, the pattern had been conveniently divided so as to give a flat or plane parting to the mold. But partings are often of other shapes, sometimes quite irregular, and cut with tools in the sand. This will be well illustrated by the method used to mold a sheave or pulley for a rope. Such a pattern is made in halves divided across the axis. The



steps of the operation are simple and easy enough; the difficulty lies in *thinking out the process*.

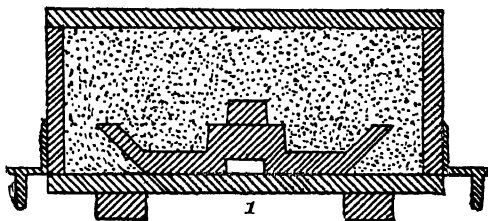

FIG. 114. HALF OF GROOVED PULLEY PATTERN IN DRAG.

In 1, Fig. 114, we have half the pattern in the drag in the usual way. In 2, Fig. 115, we have the drag rolled over and an annular crater made all around the pattern, the outer slope

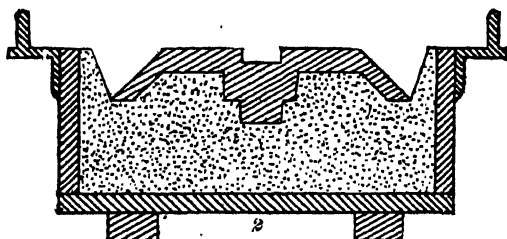

FIG. 115. SHOWING CONICAL PARTING.

being as gentle and smooth as possible, the inner slope being formed by the pattern itself. Parting-sand is now sprinkled on both sides of the excavation.

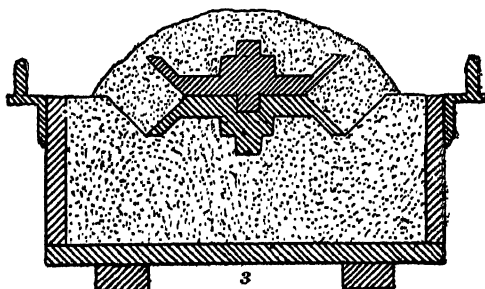

FIG. 116. MOLDING A RING OF SAND IN THE GROOVE.

In 3, Fig. 116, we have a mound of sand well rammed covering the upper half of the pattern and filling the crater, but

separated from the drag by the parting-sand. The mound is now cut down to a ring around the sheave, the upper slope being symmetrical with the lower, and left smooth. The cope is now placed in position, parting-sand is sprinkled on the ring, the cope, runners, risers, etc., are put in place, and the cope is rammed full of sand, as shown in 4, Fig. 117.

There are now three separate bodies of sand in the flask: *first*, that in the main part of the drag; *second*, that in the ring which fits into the groove in the pattern; *third*, the main part in the cope.

The next operation, of drawing the pattern, is a delicate one. Lift the cope, letting the upper half of the pattern come with it.

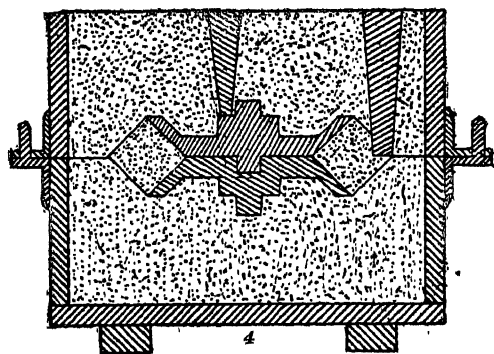

FIG. 117. SECTION OF FLASK, PATTERN, ETC.

The cope is turned over, the pattern drawn from it, and the cope is replaced on the drag. The entire flask is now turned over and the drag is lifted off. The ring of sand now rests on the sand in the cope. The other half of the pattern is now removed, the core is inserted into the "print"

in the cope, the gate is cut in the drag (around the crater left for the ring and not shown in the drawing), the drag is inverted and placed on the cope, and finally the entire flask is inverted and the mold is poured.

The *rationale* of all this may not appear to the novice on the mere reading, but it will be clear enough when the directions are taken step by step in the laboratory.

The teacher should begin with simple forms, then proceed to examples like those given above. He will readily see what intermediate steps are necessary, and will see his way to molding gradually the parts of an engine, and certain details of architecture.

The pioneer class of a school may find it necessary to take some pattern-making before molding, in order that patterns may be ready for use in the molding-room. This will however soon cure itself. To a great extent the method of uniform lessons should be followed, and the pupils must not try to run till they have learned to walk. Complicated foliage forms and the use of wax for making plaster molds are not recommended.

### *Pattern-Making.*

Assuming that the use to which a foundry pattern is to be put is understood, the first consideration is that of "draft." Draft is a modification in the form of a pattern for the purpose of making it possible to withdraw the parts of the pattern from the molding-sand which has been compactly rammed about them. Hence all pieces which are molded must be made tapering so that they may be taken from the sand without breaking or disturbing it. Many forms from their natural shape are readily drawn from the molding-sand, but the majority require special adaptation.

A second consideration is the allowance made to permit *finish* in shops subsequent to the foundry.

As a rule cast forms are only approximately correct in shape. The *exact* form of the finished piece is *contained* in the piece as cast, as the statue is in the rough-hewn block of marble, and the aim is to have just enough excess of material to permit of a true and economic finish.

In some branches of work, — stove-work for example, — the working patterns are of iron, and the cast-work approximates very closely to the required dimensions.

In a manual training school, pupils may form some idea of what is practicable in ordinary casting. Of the location and amount of the extra material to be removed in finishing, the pattern-maker must be informed.

A third consideration is that of allowance for *shrinkage* of the casting.

Allowance for draft varies with circumstances, but a fair average for minimum draft may be taken as  $\frac{1}{8}$ " in a foot, or 1 in 96.

Allowance for finish varies greatly, but for surfaces likely to be cast true and sound  $\frac{1}{16}$ " may be taken as enough.

Shrinkage is also a variable quantity depending on the metal and upon the form of the casting. Pattern-makers' rules are made  $12\frac{1}{8}$ " standard to the foot and graduated proportionally; hence 1 in 96 may be assumed as an average allowance for shrinkage.

These allowances are all to be added to external dimensions.

For example: suppose a casting be required suited to a finished block  $24'' \times 18'' \times 6''$ .

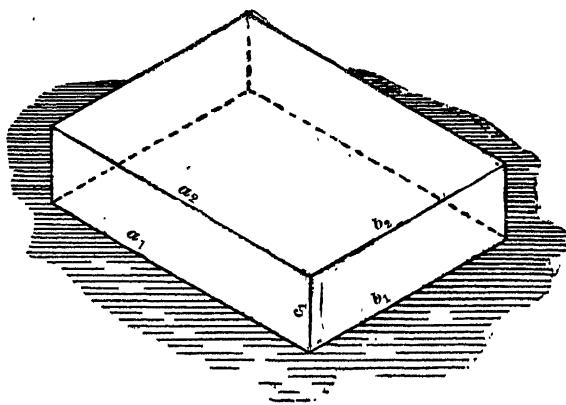

FIG. 118. ALLOWANCES IN THE SIZE OF PATTERNS.

The pattern is to be molded flat side down. See Fig. 118.

Nothing need be added to  $a_1$  and  $b_1$  for draft, but each is to be increased by  $\frac{1}{96}$  of itself, for shrinkage, and each face is to have  $\frac{1}{16}$  of an inch for *finish*. The dimensions of the base will then be:  $a_1 = 24 + \frac{1}{4} + \frac{1}{16} + \frac{1}{16} = 24\frac{3}{8}$  inches, and  $b_1 = 18 + \frac{1}{8} + \frac{1}{16} + \frac{1}{16} = 18\frac{5}{16}$  inches.

Similarly the thickness is to be  $c_1 = 6 + \frac{6}{96} + \frac{1}{16} + \frac{1}{16} = 6\frac{3}{16}$ . The dimensions of the top are to be increased still more for *draft*. As the block is a half a foot thick, the allowance on each side should be  $\frac{1}{2}$  of  $\frac{1}{8} = \frac{1}{16}$  inch, so that  $\frac{1}{8}$  of an inch more is to be added to each dimension of the top, which is therefore  $a_2 \times b_2 = 24\frac{1}{2}'' \times 18\frac{7}{16}''$ .

Thus we see that tho we want a plain rectangular block  $24'' \times 18'' \times 6''$ , the pattern is the frustum of a regular pyramid, one base being  $24\frac{1}{2}'' \times 18\frac{7}{8}''$ , and the other  $24\frac{3}{8}'' \times 18\frac{5}{8}''$ , and the thickness  $6\frac{3}{8}''$ . This example will suffice to show how the main dimensions of the pattern are to differ from those of the required piece when finished.

Very small details are often wholly covered up in the pattern.

The rapping of small patterns will frequently enlarge the dimensions of a mold by  $\frac{1}{32}$  of an inch or more, so that pieces less than about 6'' in length really need no allowance for shrinking, and hence the saying for such work: "Rappage will equal shrinkage."

The wood used for patterns should be straight grained and thoroughly seasoned.

Hard woods are often used on fine and delicate patterns, but pine is most used for general work.

It is best in arranging a pattern to have the grain of the several pieces run parallel. Shrinking (in the pattern itself, on account of drying) then takes place in the same direction on each piece, and the pattern holds together. If the grains are placed transversely, the tendency is for the shrinking to tear the joints apart, and to cause irregularities in surfaces that ought to be free from them.

Thus, if in Fig. 119 the sloping sides be finished smooth at first, after a time they will take the shape shown, the top piece becoming narrower while the lower one retains its length, an irregularity that would destroy the draft.

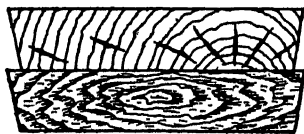

FIG. 119. EFFECT OF SHRINKING.

In spite of waterproof varnish, continued use loosens glue; hence, dependence must not be put on glue; it should be supplemented with nails or screws. All gluing should be done very neatly, leaving none on outside surfaces. Wire nails now so generally used are by far the best for pattern-work.

As a general thing even in small work it will be found better to produce a given shape by building up rather than by cutting out from the solid. To illustrate: Suppose a pattern wanted

of the form shown in Fig. 120. It is possible by sufficient care and skill to produce it from a solid block, but it would involve working out the channel, keeping the sides and bottom true and at the proper angles. Moreover, the finish with sand-paper before and after varnishing would be difficult. On the other hand, if a bevel be set at the angle suitable for the draft, a piece for the body and single pieces for the two ribs may be prepared with a plane. These pieces can be easily sand-papered and varnished in detail with no internal corners to reach, and when ready they may be put together with a few nails. With a given degree of skill a much more accurate pattern will be

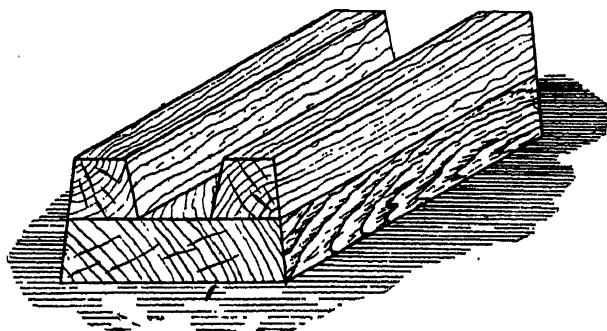

FIG. 120. BUILDING UP PATTERNS.

the result. The point of finishing parts in detail before nailing up into shapes hard to secure in any other way is well worth bearing in mind.

Patterns are necessarily exposed to dampness and should be well protected against it. One of the best means is thorough varnishing with shellac varnish. After the pattern is smoothly finished, the first application of varnish raises the little filaments that have been rubbed down. When dry these filaments are brittle and the surface is rough: light sand-papering will break off the fibers and prepare the surface for a second coat of varnish. Four or five such coats are usually sufficient. It is customary to use black varnish on the main parts of fine patterns, and light varnish on the core-prints, which gives an excellent appearance. The best light varnish is made by dis-

solving gum shellac (orange or white) in grain alcohol, no special proportions being required. For black varnish, stir lamp-black into the light varnish. A much cheaper varnish, is made by using in the same way wood alcohol instead of grain alcohol, for light color, but lamp-black causes this to curdle; hence it is unfit for the black varnish.

From what has been shown under the head of molding, it will be seen that it is desirable to have a pattern divide or separate at the plane of "parting." The parts are held in proper relation to each other by two or more pins fitting in corresponding holes. The pins should both be in the same part, and in the one which should be molded in the cope. The pins should fit snugly, but not bind in the least. They should be put in square with the parting-plane, and be short with rounded ends.

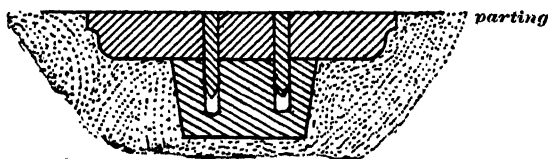

FIG. 121. SUBDIVISION OF A PATTERN.

The only general rule about deciding where to divide is that it is desirable to have each part remain in its place until rapped and drawn with the drawspike. Sometimes it is best to have more than one separation in the pattern even if there be but one parting in the flask. This is the case where the pattern is deep and safe rapping is difficult. This is illustrated in Fig. 121, which shows a separation between the deep rib and the broad top. The rib is to be rapped and drawn after the broad part over it has been removed.

In the case of an external core, we make the "print" and core of the easiest shape to mold, according to the situation. Core-prints must be long enough to ensure supports to the weight of the core without crushing the sand. Core-prints that go into the drag of a flask are made as straight as possible, since they hold and sustain the core during the closing of the flask. Those that go in the cope should have a more decided

taper to ensure proper closing, even if slightly out of line at first. The pins and sockets of the flask itself should have a perfectly easy but snug fit.

Cases sometimes occur in which it is desirable to have a small projecting piece on a pattern at a place where, if attached to the main portion of the pattern, it would render drawing impossible. In many such cases the projection is made separate and attached to the main part with pins or dove-tails, so that the main part may be drawn first, and the projection may then be drawn horizontally into the hole left by the body of the pattern. A pin may project into the sand and be drawn from the sand after the ramming of sand has been partly done. This is really forming a secondary parting, and it is evident that the principle may be extended indefinitely.

Sharp corners on patterns should be avoided whenever it is possible to do so. External angles should be rounded off, and internal corners should be filled with a small, quarter-circle outline, technically called a fillet. Strength of form and ease of molding demand this.

When possible, fillets should be of solid wood, but in many places wax is a very good substitute and is more easily applied. The wax should be worked into fine rolls between two boards which are slightly warmed. These rolls are laid along the corners to be filled, and forced evenly into their places by a rounded tool of iron or steel which has previously been warmed just enough to make the wax yield readily to its touch. In a similar way, accidental holes in the patterns may be filled.

### *Core-Boxes.*

From what has been said of core-making, it will be understood that a core-box ought to be made with a view to getting the core out with the least strain on it. It is far best to remove the box from the core, instead of the core from the box. This rather obscure remark may best be understood by considering the case of a rectangular core. If a box with a mere cover were made, draft would be necessary to make it possible to get the core out, and then with danger of breaking. Hence the box is made open at two opposite ends or sides, as shown in



Fig. 122. The box is divided along the zig-zag line JJ, while the upper and lower ends are open. The halves are clamped together, and the box is placed on end on a flat piece of sheet iron or tin, and then remains in that position while the core is rammed. The box is then unclamped and the parts are drawn apart, as shown by the arrows, leaving the core standing on the plate. It may then be carried to the baking-oven with small danger of breaking. This method of making boxes should be applied to all forms. Cylindrical cores should be left standing on their ends.

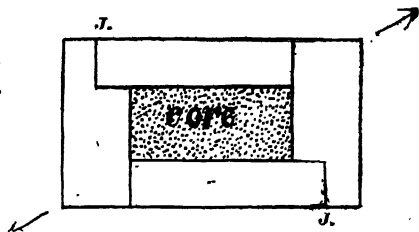

FIG. 122. HORIZONTAL SECTION OF BOX AND CORE.

Very often a core may be made in halves and pasted together. In such cases a half-box and the plate will suffice.

The building-up method should always be followed in making core-boxes, from the difficulty of executing accurate hollow forms, and for convenience in separating. The inner surfaces of core-boxes should be protected with shellac varnish, as described above for patterns.

## CHAPTER IV.

## THE THIRD, OR SENIOR YEAR.

LIKE other schools the Manual Training School suffers a loss of students as the classes progress in their course; but unlike most it holds a majority to the end. Hence our divisions will be smaller, but we shall still keep them three in number.<sup>1</sup> I shall put the maximum in each division at twenty. It will be observed that I make no provision for an instructor assistant to the teacher of a division. In this respect I differ from excellent educators. It is proper that I should give the reasons for my preference.

1. In the first place, the presence of an assistant in the care of a single division involves indirect responsibility, which should always be avoided if possible. It is impossible to define the respective duties of principal and assistant. To define them clearly would be to subdivide the section.

2. The teacher who with an assistant has charge of a division of thirty or forty boys is much less sure of his ground than the teacher with twenty under his sole direction. He can not know where they are, what they are doing, what difficulties they are meeting, what difficulties they have met and overcome, nor just what suggestion or help they need, when he has not personally seen both their work and their working.

3. He who has given the class directions and personally illustrated the method is the only person competent to criticise those who attempt to follow those directions. An assistant may come pretty near him, but there is always a sense of uncertainty, and the opportunities for honest, but unfortunate, differences of opinion are greatly increased.

---

<sup>1</sup> See page 11 in regard to attendance.

I grant that if a division is to scatter, and, like the brothers Curatii, to string themselves out in Indian file over the whole series of exercises, or over the whole range of practical work which the shop may unwisely and prematurely undertake, — I grant that under such circumstances an assistant, or even several assistants may be necessary. As the class scatters, and becomes a sort of go-as-you-please, every-man-for-himself collection of individuals, all of the characteristics of a school disappear, and class-methods are at an end, and very few pupils can be *instructed* in new work by one teacher. I was very sorry to observe this state of things in several otherwise excellent European schools, and I learn that it is always characteristic of the Swedish “Slöjd” schools. [See Chapter XIV.] The aim appeared to be to get through with a particular series of exercises as soon as possible. The rapid workers (not necessarily the best) soon distanced their fellows, and worked on in virtual independence. They completely lost the wholesome effect of class comparison and criticism in which good and bad points should be made prominent, and where what Dr. Harris calls the “leverage of the class” should be utilized to its full extent to stimulate individual intelligence.

So also if a shop takes orders and manufactures for the market, there should be several assistants who are at the same time workmen standing ready to do those parts which can not be left to the uncertain hands of untrained lads.

I think that no *competent* teacher would wish to have an assistant in teaching a division in algebra, or Latin, or English composition, or drawing. If the division were too large for one teacher, he would subdivide it and place the assistant in direct charge of one part. Perhaps I have just Italicized the word which explains the whole matter. If the person who lectures and gives general directions to a class is unable to properly supervise the practical working of the class, then certainly it is better for him to have an assistant; and I would advise him to take his place at the bench, anvil or lathe, and acquire some *primitive* ideas.

The class program is arranged as easily as before, there being three teachers and three rooms (including the shop).

## DAILY PROGRAM.

DIVISION.	9-10.	10-11.	11-12.	12-1.	1-2.	2-3.	3-4.
I.	Machine-Shop.		Geometry.	History and Literature or Modern Language.	Intermission.	Science.	Drawing.
II.	History and Literature or Modern Language.	Geometry.	Machine-Shop.			Drawing.	Science.
III.	Geometry.	History and Literature or Modern Language.	Science.	Drawing.		Machine-Shop.	

I have assumed that the teacher of drawing is also the teacher of geometry. Of course this is not at all necessary, tho I think it desirable. It is more than probable that the teacher of drawing for another class would also be the teacher of drawing for this class, there being a compensating change in either the physical or mathematical teacher. This would of course obviate the necessity of fitting up a drawing room for this class alone. As a matter of fact, it is not easy to find competent drawing teachers among teachers otherwise well educated. This deficiency will disappear as graduates of manual training and the higher technical schools become more numerous.<sup>1</sup>

The mathematics should include the usual books of elementary and solid geometry, and enough of plane trigonometry and logarithms to lead to a rational study of mensuration. Teachers of mathematics should beware of trying to cover too much ground. It is not *how much*, but *how well*, that determines the character and value of one's mathematical training. I have noticed with regret that teachers of secondary schools, particu-

<sup>1</sup> In point of fact in the St. Louis School there are four divisions in the Junior, four in the Middle, and three in the Senior Class, eleven in all, furnishing sufficient work for two teachers devoted exclusively to drawing. The two drawing rooms are used exclusively as such.

larly in the West, have been inclined to push their pupils prematurely into the study of analytical geometry and even the calculus. The inutility, nay the harmfulness of such efforts has been only too evident. At best, the pupils get only a very shallow notion of those vast subjects, and no adequate conception of the uses to which they may be put; while on the other hand, they often get the impression, that their understanding of such subjects is about on a par with the attainments of a *well-taught* mathematician, and that their inability to see any practical use in such studies is sufficient proof that there is no real practical need of such studies to practical men. No result more fatal to high scholarship and successful engineering could be found. A student knows his algebra only when he is so familiar with its various operations and methods of application, that it comes as naturally into his hands as an instrument of investigation as does his arithmetic or the principles of physics.

It is the same with geometry, which is not so much a collection of facts about geometrical figures and solids, as the embodiment of methods of reasoning which are of the first importance to every reasoner. Unless a student can readily block out the steps in the argument without the conscious use of a word, he can not be said to *know* geometry. When a class is hurried through the subject, not, as is often said, for the purpose of becoming experts, but for the sake of the *broad culture* that is supposed to result, it fails. Neither skill nor culture results; it is only a shallow conceit and a misapprehension of the whole matter. Such people are without the training necessary to just appreciation of either sound learning or high culture.<sup>1</sup>

---

<sup>1</sup> An eminent mathematician and professor of engineering recently told me that while in a city high school he was put through a whole range of college mathematics. As should have been expected, he attained to no comprehension of the subjects, and decided that he had no mathematical capacity. Of course he hated mathematics with all his heart. History however was his delight. Later he went to a higher institution, where the course was thorough, and again he went over the whole course of pure and applied mathematics with a mind properly matured. It was a revelation to him. Instead of having no mathematical ability, he found he had abilities of a high order. He is clearly of the opinion that the time spent in the high school on the higher mathematics (beyond geometry and algebra) is worse than wasted.

The science study of the Senior year should embrace practical and some theoretical chemistry, physiology, and some of the principles of book-keeping. The comparative inutility of chemistry without a working laboratory was long ago shown. No laboratory work has been more thoroughly worked out than that of chemistry. In nearly all European and English schools of secondary grade, chemistry is admirably provided for. A laboratory accommodating twenty pupils simultaneously is really an essential feature of a manual training school. The details of such a laboratory are easy to find.

Book-keeping is introduced, not for the purpose of making book-keepers, but for showing how very simple book-keeping is when its principles are clearly seen. There are countless good ways of keeping books, adapted to a great variety of conditions, and all are perfectly intelligible to a well-taught person, who understands a few simple propositions.

The language study may be quite varied in the different sections of the class. Some will certainly want a year's study of French or German, in accordance with the requirements of institutions of higher education to which many of the boys are looking forward. Such boys should in common with all the rest of the class devote one day each week to the study and practice of English composition. The students are now at the age of seventeen or eighteen years, and are capable of appreciating style, and of beginning to form styles for themselves. Nothing but a persistent study of the styles of good writers, and a conscious attempt to imitate them, will lead to the habit of writing clearly, purely, and concisely.<sup>1</sup> The principles of political economy treated in a very elementary way may here be studied with great interest and profit.

The principles of civics should be quite fully considered in connection with something like the following scheme. I doubt very much the use of a class text-book on this subject. A good teacher can easily *lead* his class into a very thoughtful study

---

<sup>1</sup> A chapter of Buckle; a lecture of Tyndall; a poem of Longfellow's; a letter of Junius; a play of Shakespere; a life from Smiles; will go far in showing what really good English is. Above all, avoid the stilted style of Irving's Westminster Abbey, and the extravaganzas of Carlyle and Ruskin.

of the subject; and the joint preparation of a *syllabus* will develop more interest and make a deeper impression than any mere text-book, however skillfully written.

I suggest a course somewhat like this:—

1. A careful analysis of our *scheme of government*, national, state, and municipal, with a general statement of the functions of each. If this statement is re-made and re-arranged and re-illustrated with every new class, the teacher may be sure of a lively and fresh interest. Fine distinctions and exact limits must be omitted.

2. The *necessary expenses* of each of the governments, with a detail of the institutions which must be supported by taxation.

3. The various methods of *levying and collecting taxes* in actual use.

4. The *duties of citizenship*, such as, —

(a) The maintenance of individual independence, by *earning one's own living*.

(b) The contribution of one's share by *taxes* to the necessary expenses of government.

(c) A prompt and active participation in all measures necessary to secure the selection of faithful and competent public servants to discharge the duties of legislation and government; i.e., to *elect good legislators and officers*.

(d) The cultivation of a *proper public opinion* in favor of honesty, temperance, and the refinements of civilized life.

(e) The contribution of something, small or great, to the *common weal*, beyond the duties in (a), (b), and (c), whereby the world may actually be the better for one's having lived in it.

If a teacher does no more than to discuss these points with his class (a few other points might come in, tho I would be careful not to attempt too much), say twice a week for ten weeks, and at the end arrange and print a *syllabus* covering all the ground gone over, and leave a copy in the hands of each pupil, he would do a most useful work, and about all it is wise to undertake in a school of secondary grade. The rest of the language allowance of time may be devoted to general history and the study of Grecian mythology.

## DRAWING.

The drawing takes on this year a more finished shape. For the first time in their course, the students are prepared to appreciate and profit by a course of purely geometrical drawing. The object of this is not to commit to memory solutions of particular problems, or to dispense with T-square and triangles, but to get some adequate idea of instrumental accuracy, and a ready command of methods of close approximation. The teacher should, however, avoid giving, as exact, a method which is after all only approximate. In an absolutely exact method, the closer the method is followed, the more nearly exact will be the result; if the method be only approximate, the reverse result is possible.

Line and brush shading of geometrical forms (spheres, cones, cylinders, etc.), with the outlines of simple, easily formed shadows, prepares for the drawing and shading of forms based on the geometric, in architectural and machine drawing. A certain amount of pen and ink sketching, first from copies (to get command of the style) and then from objects, greatly increases one's ability to make a rapid, freehand drawing (projection or "pictorial," as may be best suited to the case). In this work the student should aim at a faultless style of freehand sketching from actual examination and measurement. If possible these sketches should be done well the *first time*, i.e. the student should not make poor sketches with the expectation of copying them "in style" at his leisure. The first sketches should be as nearly perfect as possible; a second set made *from them* would have little value except to show how the first should have been made.

A finished, shaded drawing of some structure or working machine with full details is intended to finish the course and to embody nearly all that the student has learned in drawing. It should include some tracing or drawing with ink on cloth. The chief drawing should be of large size, and all the work should be clean and exact. The lettering and border should be carefully done, and in a style to suit the drawing. This work completes the year. It may be objected that instead of



making such an elaborate drawing the student should confine himself to details in the usual unshaded style, as in practice the finished drawing is rarely used. My answer is that one's school training should always go far beyond the demands of ordinary practice in order to give that sense of mastership which comes from an acquaintance with a larger field than that in which work is actually done. One who has once *finished* a drawing, has not only a high ideal, but he has acquired a certain judgment of what constitutes appropriateness in a drawing. The only thing I would discourage in drawing is the practice of methods which appear to be purely arbitrary, for which no reasons are given, or which are so dependent on descriptive geometry, as not to be within the reach of elementary students.

It will be noticed that nowhere do we aim specifically at artistic culture. The students are not taught to prefer inaccuracy to accuracy because one is made freehand, the other with the aid of instruments. To be sure, the inaccurate drawings *may* involve more skill than the accurate one, and no one is more ready to appreciate that than our students, and in 'so far as a drawing gives pleasure by containing evidence of skill, they are reasonably quick in their appreciation. A drawing whose object is to give pleasure may do so in three ways: 1, by being intrinsically true, harmonious, and graceful; and 2d; by its display of skill in its approximations; and 3d, by a judicious use of conventionalities.

I claim that the students who have completed the course I have laid down have an admirable foundation for artistic study should they care to cultivate it.

#### THE THIRD-YEAR SHOP-WORK.

The shop arrangements for the third year are by far the most elaborate and expensive of all the school apparatus, and they will often be beyond the means of many institutions which can readily furnish the wood-working shops. Moreover, the equipment of the "Machine-Shop" will be likely to vary widely from various causes. It will scarcely be possible to maintain rigidly uniform and simultaneous exercises.

An engraving of a portion of our machine-shop, taken from a photograph, is shown in Fig. 123.

The kinds of tools which are regarded as typical in character are:—

The machinist's vise, heavy and strong.

The machinist's hammer, and cold chisel, and a set of three files.<sup>1</sup>

The engine lathe, the speed lathe, the planer, the shaper, the drill-press, an emery grinder, a grindstone, and a forge for dressing and tempering tools.

There are various excellent patterns of tools, and there is a great range of prices. The tools which our experience of from four to eight years with several different kinds leads me to commend are as follows, with an approximation to their cost:—

Engine Lathe, 14 inch swing, 5 ft. bed, made by the Putnam Machine Co., Fitchburg, Mass. . . . .	\$250
Planer, 21"—21"—60", by same company . . . . .	400
Gooseneck Drill, 25-inch, by same company . . . . .	365
The Shaper . . . . .	350
Speed Lathe, with short iron bed, from . . . . .	50 to 80
A Post Drill . . . . .	40

The present equipment of the St. Louis school contains sixteen engine lathes, six speed lathes,<sup>2</sup> two drills, one planer, one shaper, two emery-grinders, two grindstones, a gas-forge, and about a dozen vises.

The gas-forge being in use only occasionally, needs no flue. The air-blast, which in the St. Louis school is furnished by a Westinghouse brake apparatus, may be produced by a foot or hand blower, or by a connection with the forging-shop blast.

#### THE CHARACTER OF THE TOOL INSTRUCTION.

The students have thus far had no experience with metals beyond that gained in the forging-shop where *heat* was the

<sup>1</sup> The cold chisels and perhaps the hammers may have been made during the second year by the students themselves.

<sup>2</sup> Two of these speed lathes have been made by the third-year class during the present year. The details are simple, and with care the boys have been able to produce some very good work.

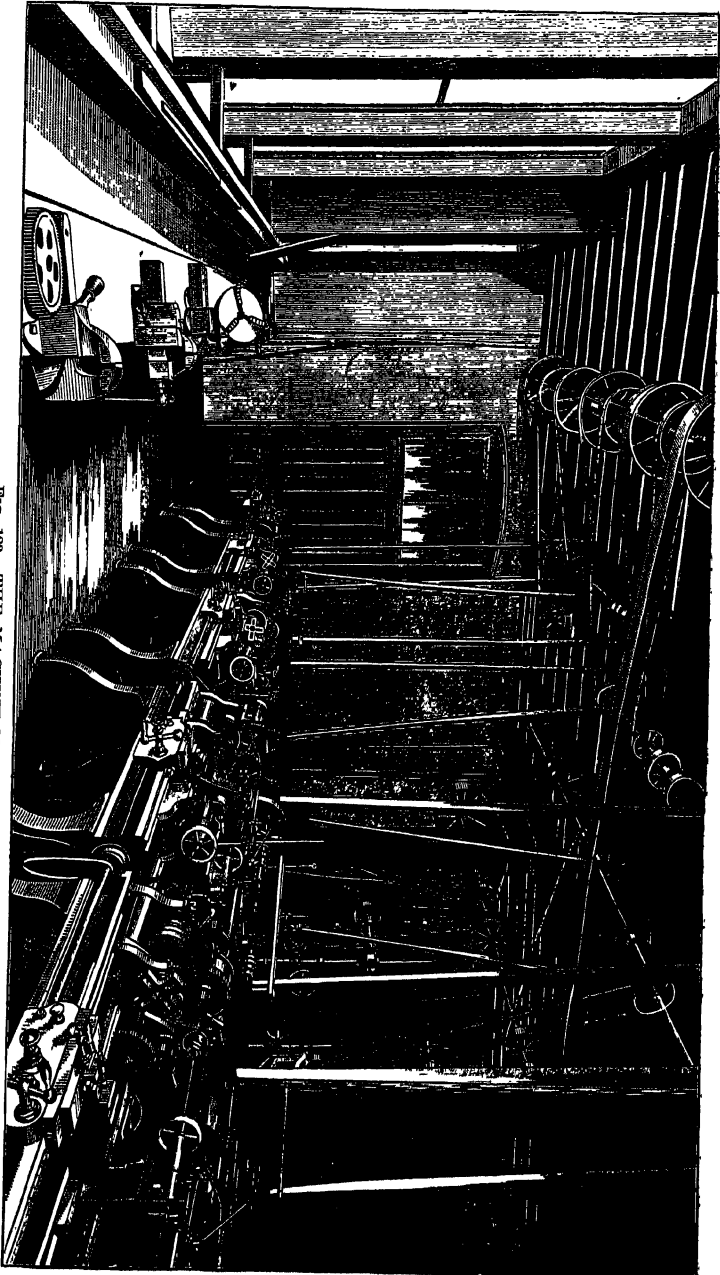

FIG. 123. THE MACHINE-SHOP.

This cut gives a view only of the double row of engine lathes and one long bench. Six of the large lathes, the six speed lathes, the planer, the shaper, the forge, the emery-grinder, and the other benches are invisible. The belts have largely been removed in order to let the machines appear. The shop accommodates twenty men at a time.

influence which rendered the stubborn metal tractable and subservient to the hammer. Very little was attempted without heat; it was the universal solvent.

Now, however, the metals must be wrought cold. They are to be cut with the chisel and file, to be planed, to be turned, to be drilled,—in fact, they are to submit to processes very similar to those in use in the wood-working shop; but the tools are to be peculiar, and the methods altogether new to the boys.

The steel tools must be strong, well-tempered, forged and ground to specified shapes, and correctly adjusted. A failure in any one of these respects is a complete failure.

In the following sketch of the functions of the different tools, and the exercises by which those functions are taught, no attempt is made at exhausting the subject. What I shall say will be of value, not to the teacher who should be thoroughly familiar with the theory and the use of every machine, but to the students themselves and to parents and supervising officers in giving a clue to the extent and variety of the exercises.

I shall take up the tools in a logical order, though it will readily be seen that there may be great variety in practice.

### *Speed Lathes.*

1. Speed lathes, or "hand" lathes, are used for: (a) Centering, (b) Hand-tooling, (c) Polishing.

(a) Centering consists in pricking, drilling, and counter-sinking holes in the ends of a cylindrical piece of metal so that it may be firmly supported on the taper centers of the lathe. If the piece is irregular, pricks are made by a punch as accurately as possible, and then the piece is put into the lathe and turned by hand. If the adjustment is bad, the side too far out is readily found by letting it rub a bit of chalk as it revolves. New pricks are then made till centers sufficiently exact are found. The pricked holes are then drilled out by a  $\frac{1}{8}$  inch drill to a depth of about three-eighths of an inch, the drill being held by a chuck in the lathe, and the piece held by the hand against the tail center. The holes are counter-sunk by a similar method, the counter-sink having the same taper angle as the

lathe centers. The holes are deep enough to escape the points themselves.

Centered pieces when put in a lathe are driven by means of a "dog." A "dog" is a ring of metal large enough to fit over the end of the centered piece, with a set-screw on one side by means of which it grips it firmly, while on the other side it has a bent arm which bends back into a face plate which is screwed to the spindle. The face plate drives this arm (or tail) of the dog, which in turn carries round the piece.

(b) Hand-tooling consists of shaping a piece in a lathe by means of tools *held in the hands*. It may have been partially shaped by machine-held tools. The tools necessarily have long handles, and are generally either files, the "round-nose," or the "square-jawed" tools. It is plain that a great variety of tools may be used. Formerly a great deal of work was done by hand-held tools. As a rule, spherical, and conoidal surfaces, with free outlines, are turned by hand; cylinders and cones are turned by machine-held tools. See exercises Nos. 2 and 4.

(c) Polishing is a process by which surfaces are made bright and smooth, or by which they are given a "finish." It is usually done with loose emery powder and oil applied with a fine stick held in the hands, or by emery cloth and oil, the stick or the cloth being pressed stoutly against the rapidly revolving piece.

#### *Engine Lathes.*

Engine lathes differ from hand lathes in being larger and stronger, by having "back-gears," and generally by having screw-cutting attachments. Through the courtesy of the Putnam Machine Co. of Fitchburg, Mass., I insert a cut of their 14-inch lathe as Fig. 124. When a piece of large radius is being turned, it should turn very slowly and yet with force enough to overcome the resistance of the cutting tool on its extreme part. This double result is effected by means of the "back-gear," which is readily thrown in and out. By means of the cone pulley and the back-gears, a great variety of speeds may be obtained tho the counter shaft moves with uniform velocity. The student should calculate the method of securing the proper speed.

The speed with which pieces should turn depends upon the diameter of the part under the tool and the hardness of the material. The cutting always produces heat, but this heat should not be high enough to affect the temper of the cutting tool. The usual speed for a cutting tool is from 17 to 19 ft. per minute. A tool cutting steel and wrought iron should be well

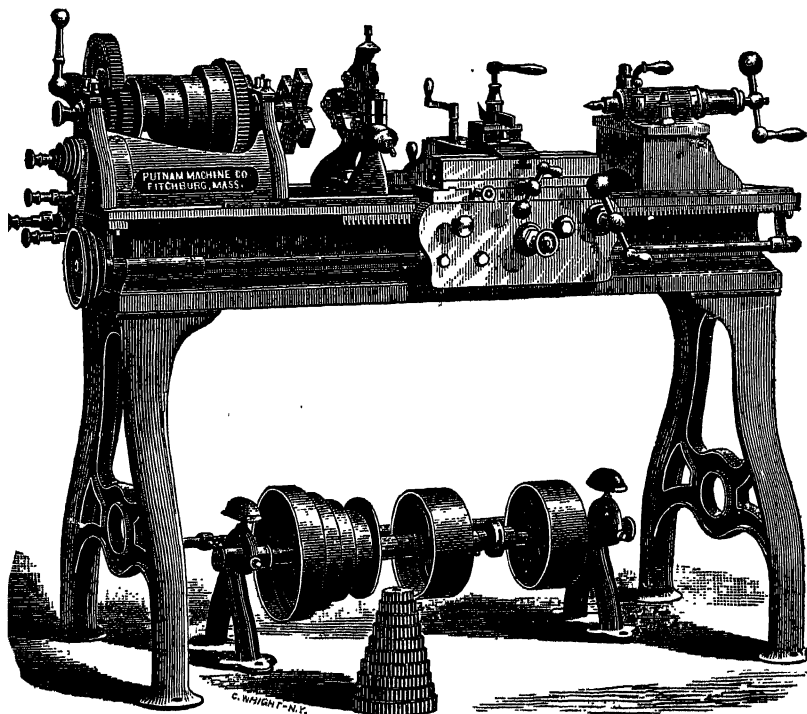

FIG. 124. A 14-INCH ENGINE LATHE.

oiled, while those cutting cast-iron may be dry. The reason is that the chips of the former do not break, but bend and slide along on the end of the tool more or less, producing heat from friction unless oiled. Cast-iron chips break off quickly, so that oil is generally unnecessary. A "tap" cutting an internal thread should always be oiled no matter what the material, in order to diminish the heat of friction. Instead of oil on an external tool cutting iron or steel, soda water, or water alone

is often used for lubrication (and smoother cuts) and for keeping the tools cool. The size of a cut depends upon the hardness of the piece, the speed of the lathe, the length and strength of the tool. Experience is necessary to appreciate these matters.

The principal tools used in a lathe are the "squaring-up" tool, the "diamond-point," the "round-nose," the "thread-cutting" tools, and the cutting-off or "parting" tool. The shapes of these tools are the result of years of practice and experiment, and their characteristics should be carefully noted. The students have already become familiar with their proportions, while forging them during the previous year. It is a good plan to have a standard set of tools ground to definite dimensions by the experts of a first-class shop, and to keep them for comparison only, while dressing and grinding the tools to be used in the lathes.

The teacher will not attempt to explain the entire lathe short of several lectures. Its various mechanisms are to be shown and their uses illustrated. Cylinders, cones, shoulders, right and left V-threaded screws, right and left square-threaded screws illustrate the simplest exercises. The feed table may generally be driven by a belt, but the cutting of a screw requires gears that cannot slip. The class should be shown not only how to use the directions attached to the lathe for cutting certain numbers of threads per inch, but they should understand how to select the right gears independently, for any number of threads.

The uses of back-rests, center-rests, mandrels, face-plates and chucks are to be shown in succession. The cutting of threads in nuts and interior work requires special tools.

It will soon be evident that though the lathe may be an instrument of great precision, good work will not be done unless it is intelligently used. The cutting tool and the piece to be cut must be mutually adjusted in perfect harmony with the theory of the machine or the attempt to use it will be a failure.

No attempt should be made to exhaust the capacity of a lathe. The expert will see that I have named but a small part of its possible uses.

### *The Planer.*

The planer may come next. This tool is used for making plane surfaces, for reducing to uniform thickness, for beveling and for cutting slots or grooves. The theory of the planer is easily presented and very interesting. The methods of adjusting and clamping the work are most ingenious. The exercises on the planer should involve several of its most important adjustments. No change of speed is admissible on the planer.

### *The Shaper.*

The shaper, or "jumper," as it is often called, is a small and rapid planer. The tools used are the same and their use similar; there is however this difference: in the planer the tool is stationary while the work moves; in the shaper the converse is true. In each machine the return motion is more rapid than the advance. The construction and use of the shaper are readily learned.

### *The Drill-Press.*

The drill-press has a large range of work, and is easily understood. I give a cut of this truly elegant tool in Fig. 125. Like the lathe it has a combination of cone pulleys and back-gears for regulating both speed and power. It has both hand and power feed and a quick return of the spindle. The small tools used in the drill-press are: drills, twist-drills, chucks, boring bars, and cutters. The chief difficulty in using the drill consists in properly supporting or clamping the piece to be drilled or bored. A smaller post-drill may be thought sufficient for a small shop.

After general lectures on the planer, shaper, and drill, single students are put at each, and are closely watched and instructed by the teacher personally. As soon as they are familiar with their work, they are set to teach what they know to a new set of boys. Later on these last boys become teachers of a third set, and so on till each has become acquainted with the tools and has executed the specified exercises; the supervision required from the teacher is thus reduced to a minimum. Meanwhile the lathes are kept in systematic use.



In all machine-work the great practical difficulty lies not in the proper adjustment of tools and of work for rigid material, but

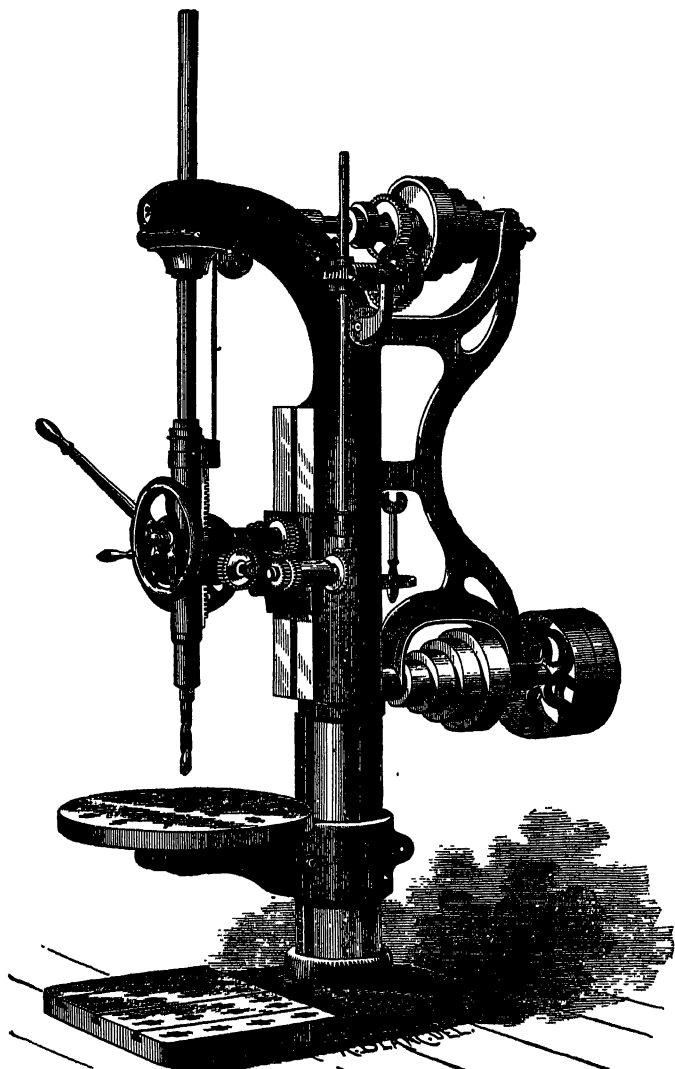

FIG. 125. "GOOSE-NECK DRILL," PUTNAM MACHINE COMPANY, FITCHBURG, MASS.

it arises from the springing of both tool and work when under strain. No tool is so rigid as not to bend, and no piece can be

so securely clamped or supported as not to yield when subjected to pressure, and the yielding is greater for points farther from the supports. Hence, pieces which should be long cylinders are larger in the middle than at the ends; screws which easily receive nuts at their ends, bind persistently farther down; and so on in various ways. Again, iron and steel are not homogeneous; cast-iron in particular is full of inequalities. Hard spots are found where the tool bends excessively. This may not be visible to the eye, but it makes itself known in the case of snug fits. The necessity of running the tool over the work a second time for the purpose of removing the inequalities due to unequal hardness becomes obvious in actual work. Good judgment in dealing with these difficulties is the result of intelligent observation and continual practice. In no manual training school can one expect much practice; consequently the students cannot be expected to have the skill which only practice can give. A great deal has been accomplished if the students have seen the real nature of the difficulties, and the necessity of a wide experience in order to successfully meet them all. The necessity of clearance in the care of every cutting tool is very great. In the first place it saves unnecessary friction and heat, and in the second it saves a great loss of power. The teacher will do well to illustrate this important point by the use of tools of improper shape, and so show "how not to do it" by developing great heat and heavy resistance.

### *Bench-Work.*

Bench-work consists in the use of hand-tools at the vise, and mainly consists in "chipping" and "filing." Chipping is cutting with a chisel, usually called a "cold" chisel, as it cuts cold metal. Each student should have a chisel properly forged and tempered by himself during the previous year. It is possible that a hammer may have been made, but as a rule the machinist's hammer is beyond the skill of a novice, and only good tools should be used. Chipping is rather rough work, and very moderate exercises should be given. The student should learn the difference under the hammer between cast and wrought iron, between soft and hard steel. He should know when the

chisel may be used to advantage, and when not. Great skill in striking should not be aimed at. Great care should however be taken to have the chisel in good order and to show its proper position for cutting. It is perfectly proper to use a thick, leather glove on the left hand; no useful end is accomplished by injuring one's hand by a wild blow of the hammer.

The chipping exercises may properly consist in taking off corners, in chamfering two adjacent edges, in cutting a slot, etc.

Filing, tho not hard work, requires great patience and attention to style. Each exercise given should be brief, and should distinctly teach one thing. Filing may relate to quantity or to quality. Special shapes may be required, or special surfaces. Then there is a great variety of material. It is a great mistake to spend a great deal of time in an attempt to do a very difficult thing, such as making a set of absolutely plane surfaces, instead of having a large range of simple exercises, many of which may be executed on the same piece of material. If the student knows when each variety of file is to be used, and how to use it fairly well, and when the file is in order and when not, when to draw a temper before filing, and when to first chip or use a drill or planer — he has learned what is far more valuable than the experience in a probably futile attempt to make a pair of surface plates.

#### EXERCISES IN IRON-WORK.

The special exercises by means of which the uses of the various tools are to be taught may vary greatly. The following list is given, not because they are better than any others, but because in our shop many of them have well borne the tests of several years' experience. The stock in some of them admits of use year after year, the dimensions required being changed, until it becomes practically used up. Special reasons may lead to modifications, but these exercises will serve well as a basis. In the fittings of a wood-turning shop, face-plates are needed, and they may very properly take the place of certain lathe work in the machine-shop.

**No. 1. (Fig. 126.) Plain cylinder.** Stock, wrought-iron, one inch round,  $6\frac{1}{8}$  inches long. After it is turned in the engine lathe, the piece is filed and polished in the speed lathe.

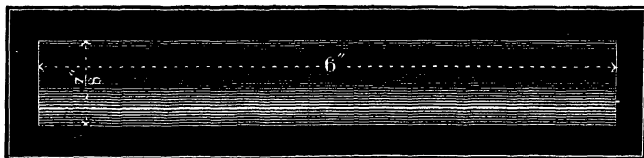

FIG. 126.

**No. 2. (Fig. 127.) Taper piece.** The stock may be found in No. 1. The shoulders of the chambered part are to be kept square, while the head end of the piece is to be turned spherical. Turning the taper is one of the most interesting operations of the lathe.

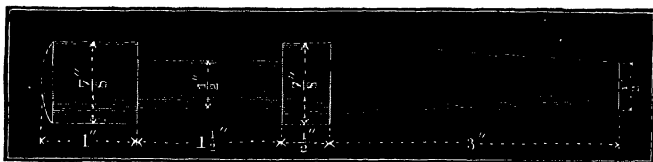

FIG. 127.

**No. 3. (Fig. 128.) Right- and left-handed screw.** Stock same as Nos. 1 and 2. The central groove is cut and the ends are turned down before the threads are cut. There are ten

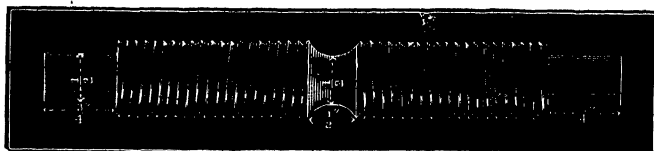

FIG. 128.

V-threads to the inch. It must be borne in mind that all the cutting-tools except the files and drills are made and kept in order by the students themselves.

**No. 4. (Fig. 129.) Finished handle.** Stock  $1\frac{3}{8}$ " round iron,  $4\frac{3}{8}$ " long. The handle is approximately formed and the thread is cut in the engine lathe. In the speed lathe, by the use of hand tools, the free outline of the handle is obtained, and then

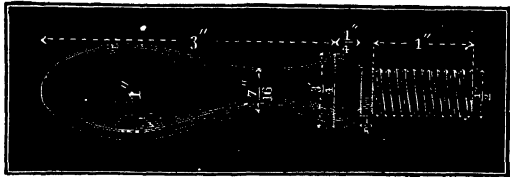

FIG. 129.

the main portion is given a high polish. The thread is of the standard description, so that the handle might replace one on the lathe itself.

**No. 5. (Fig. 130.) Bolts and nuts.** The stock consists of blank bolts and nuts with an excess of  $\frac{1}{16}$ " of material on every side. Each student makes three of these bolts and three of a slightly smaller size. Every surface is to be well finished. The threads in the nuts are cut with a tap, and the three nuts are put in a common mandrel and planed to the required hexagonal form in the "shaper." Errors in the final dimen-

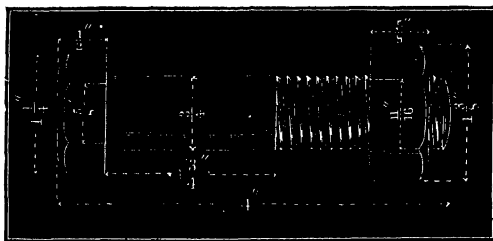

FIG. 130.

sions—and of course there will always be errors—are considered in the marking of the exercise.

**No. 6. (Fig. 131.) Parallel piece.** This involves *planing*, *drilling*, *chipping*, and *fling*. Stock, cast-iron, a rough block. This is planed down very closely to exterior dimensions. The outline of the central hole or slot is traced, and holes are drilled

within the line, and the core is taken out by the broach. The interior is then chipped out and filed. The planer, the drill-press, and vise are employed in this exercise. The aim in filing

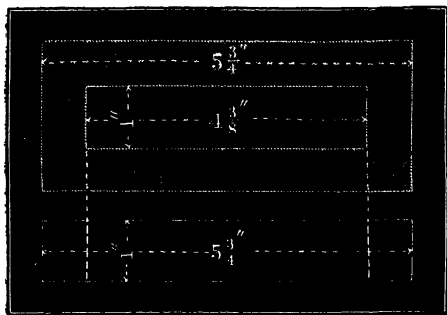

FIG. 131.

**No. 7. (Fig. 132.)** Similar to a valve seat. Planing, chipping, and filing. This exercise involves some of the preceding, with more difficulties in adjusting the piece in the planer. The piece is used several years in succession. Each year the dimensions of the slots are increased, while the exterior dimensions are diminished. All the surfaces worked are to be left true and polished. The stock to begin with was a rough iron casting, about eight inches long.

**No. 8. Chipping off rivets.** See Fig. 82 among the forging exercises. Last year the student put in these

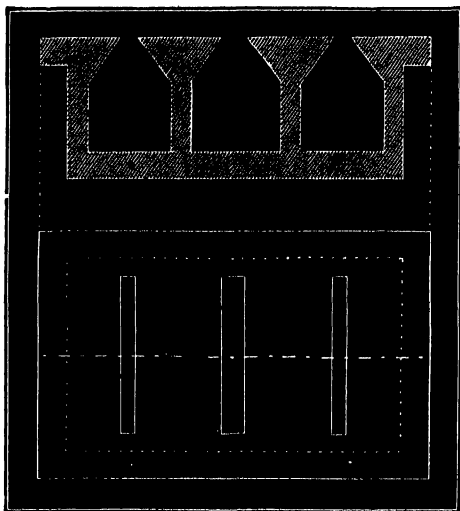

FIG. 132.

six rivets to the best of his ability; he is now to learn how and with what labor they may be cut out and the plates sent back

is to produce plane faces to the slot, parallel to the sides and ends of the piece. All the faces exterior as well as interior are to be finished by hand. The exercise is very difficult. Only fair results are to be required. The skill of an experienced workman is not to be expected.

to the forging-shop to be re-riveted. With care the drilled holes may be left uninjured, and the plates may be used over and over again for several years.

**No. 9. The dog.** See Fig. 90 among the forging exercises. The main shank is now to be centered, the head dressed, drilled, tapped, and furnished with a steel set-screw with a hardened point. The dog will then be available for use in the lathe. If the supply of dogs is ample, a new exercise in drilling may be substituted.

**No. 10. The pin and flanged nut.** Fig. 133 gives two views of the pin, and a section of the flanged nut. The material is all cast-iron. The exercise contains a great variety of points, and calls into use many tools and processes. Both threads are cut on the lathe, and all surfaces are to be finished. It is obvious that the pin may be used a second time, with less dimensions; the flanged nut may be used with a *larger* pin.

**No. 11. Shaft couplings.** Fig. 134 shows how two pieces of shafting may be coupled together, and how flanged collars and pulleys may be fitted to the same. All except the pieces of shafting are shown in section, and four kinds of fitting are

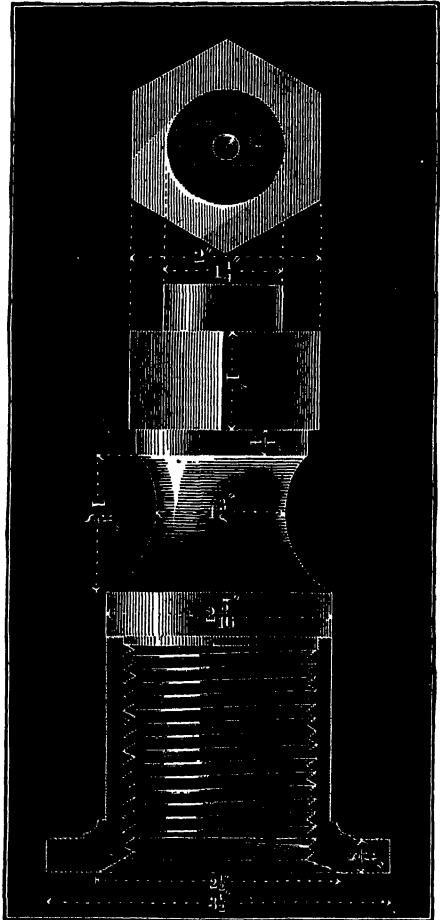

FIG. 133.

illustrated. The combined piece is finally finished in the lathe as a unit. The disks are usually about five inches in diameter, and the whole length is about fourteen inches. The flanges are of cast-iron, while the shafting is wrought-iron. Each of the "fits" has a method peculiar to itself, and gives opportunity for valuable experience.

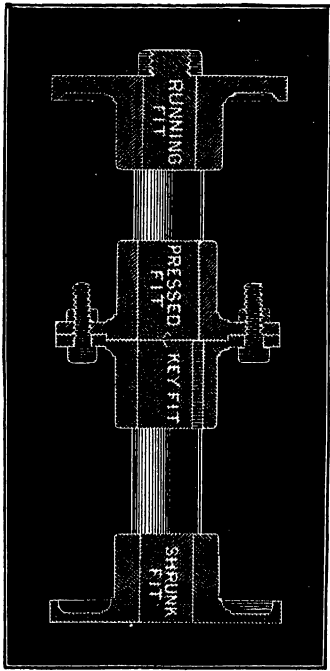

FIG. 134.

In marking the results of this work the teacher should determine his scale as he goes over and explains the work before the class, and this scale should be fully known and understood by the class. Moreover, the work should be passed upon at every stage. A poor job of lathe-work should not be covered or concealed under a long job of filing in the speed lathe; nor should one error in dimensions be canceled by another. The methods by which a result is reached

should be marked as well as the concrete result itself.

### *Projects.*

When these exercises are finished, a variety of combination pieces may be executed by the members of a class jointly or separately. These projects should be carefully matured, detail drawings of all the parts should be made, often patterns should be made for cast-iron work. Jack-screws, speed lathes, electrical apparatus, and small engines furnish abundant and interesting work on which to combine the exercises into particular shapes. There is great danger, however, of undertaking too much.

I strongly advise against undertaking work so large that much of it has to be done outside in commercial shops. The tools I have described and used are small when compared with



those in actual use in large establishments; and I suggest that the class be taken to see large and heavy work done as soon as they have had experience in light and easy work.

My readers will of course observe that I have not tried to make a factory out of our school-shop. No defence of my course ought to be necessary, but there are so many people who think that the moment we put the theory and use of tools into a school curriculum, we must abandon approved educational methods and transform the institution into a manufactory, that I have elsewhere discussed this point at some length. I must refer my readers to that discussion in subsequent chapters. They may be sure that this discussion forms no part of the school proper.

## CHAPTER. V.

## THE RECORD AND TESTIMONY OF GRADUATES.

IN Chapter VIII. I shall give in detail the "Fruits of Manual Training," partly *a priori*, and partly as seen by one actually in charge of a manual training school. I now propose to give the results as shown by the roster and testimony of our graduates.

I am well aware that I am undertaking a dangerous task. In the first place, it is difficult, if not impossible, to tell what is and what is not the result of our training. In the second place, the testimony of graduates is liable to be biased in favor of the course they took, on the principle that one should speak well of the bridge that brought him over, even if it is a very poor bridge. This difficulty I must share with others; and as my graduates are not more prejudiced than the graduates of other schools, their testimony must not be unduly discredited. In the third place, the time is all too short for full results to appear. I can not point to a long list of worthies who date the beginnings of honorable careers with their training here. Our oldest graduates left us less than four years ago. But I am willing to trust the future. Such testimony as I can give is submitted with confidence and a desire to be both frank and fair.

The following circular letter will explain how I went about my investigation:—

MANUAL TRAINING SCHOOL, ST. LOUIS, July 25, 1886.

DEAR SIR,—In a book soon to be published, I desire to give as fully as possible the statistics of the graduates of the Manual Training School for the purpose of showing (so far as such things can be shown at this time) the results of the training afforded by the school. No names will be used in my analysis of these statistics, so I hope you will write with the utmost

frankness. I wish to get at the TRUTH both when it makes *against* our school and when it makes *for* it. If I quote from your letter I shall not give your name, though your classmates may be able to infer it.

I wish to know:—

1. Your address and the precise nature of your present or prospective occupation; and if employed, how you are classed on your employer's books.
2. If employed, your present (or recent) wages per month or year.
3. How your position and pay compare with those of other young men of your age in the same or similar establishments.
4. What you now think of your training at this school; its good points, its deficiencies, its advantages, and its disadvantages.
5. Under what circumstances would you, or your parents, or your employer advise a young man to come to this school.
6. What your employer or immediate superior thinks of the result of your school training; as to general intelligence; habits of promptness and precision; as to skill of any kind; as to ability to understand what is new, and to do as you are directed; as to your ability to bear responsibility, and to direct others; as to your ingenuity; as to your defects and failings; as to your manners and general habits. Would he be disposed or not to give the preference to a graduate of this school, were he in want of a new clerk, assistant, draughtsman or apprentice workman, from eighteen to twenty years of age.

I suggest that you answer the first five questions yourself in a carefully written letter to me, and that you then place this circular in the hands of that one who can best reply to questions 5 and 6.

Wishing you the highest success, I remain your friend,

C. M. WOODWARD,  
*Director.*

I shall first give as fully as I can the present occupations of my students; this will show their positions in society. Secondly, I shall give the average monthly wages of those who are earning money. Thirdly, I shall give extracts from the letters I have received in response to my circular. And here let me add, that in all this I evidently put my best foot foremost. The unsuccessful graduates are not likely to answer my letter, and though it would be manifestly unfair to assume that those who have not responded have nothing favorable to report, it is unquestionably true that those who have not written me would make on the *average* a poorer showing than that given below. How is it with the records of graduates of other schools?

## THE OCCUPATIONS OF GRADUATES.

*Class of 1883.*

- Henry H. Bauer, Farmer, Dorchester, Ill. .  
 John Boyle, Jr., B.E.<sup>1</sup> Fifth-year student in Mining Engineering, Washington University.  
 John L. Bryan, Head Turner in Pipe Works, Washington, Mo.  
 Alex. W. Buchanan, Student in Mechanical Engineering, Cornell University.  
 Peyton T. Carr, Clerk, Office of Insurance Commissioner.  
 Edward E. Davidson, Partner in Real Estate Business, St. Paul, Minn.  
 Cornelius V. De Jong, Machinist.  
 Harry Deitrich, Machinist, Draughtsman, Patternmaker, etc., Brass Foundry, St. Louis.  
 William S. Dodd, Collector, Laclede Gas Works, St. Louis.  
 Henry F. Dose, Student, University of Illinois.  
 Wm. J. Downton, Architect's Office.  
 Theo. Gluck, Senior Class in Mining Engineering, Washington University.  
 S. D. Hayden, Clerk in Southeastern Railway Office.  
 Robert L. Hyatt, Farmer, St. Louis County.  
 Conrad S. Ittner, Jr., Bricklayer.  
 Wm. B. Ittner, Student in Architecture, Cornell University.  
 Albert L. Johnson, Senior Class, Civil Engineering, Washington University.  
 Wm. Love, Assistant Engineer, Missouri Pacific Railway.  
 Harry W. Lytance.  
 Robert H. McMath, B.E., with Adolphus Meier & Co., St. Louis.  
 Otto L. Mersman, Merchant, St. Louis.  
 Wm. G. Nixon, Clerk, Supply Department, Iron Mountain Railway.  
 Everett G. Phillips, Engineer and Shoemaker, St. Louis.  
 Wm. K. Roth, Grocer, St. Louis.  
 Justus W. Schmidt, Draughtsman, Architect's Office.  
 Greenfield Sluder, Medical Student.  
 Jules C. Smith, Machinist.  
 Herbert Taylor, Salesman, Simmons Hardware Co.  
 John P. Thul, Senior Class, Dynamic Engineering, Washington University.  
 John F. Vallé, Clerk in Commission House.

*Class of 1884.*

- Grant Beebe, Senior Class, Dynamic Engineering, Washington University.  
 A. Theo. Bruegel, Senior Class, Mechanical Engineering, Lehigh University.  
 Geo. R. Carothers, Principal Technical School, Cincinnati, Ohio.  
 Walter R. Coles, Clerk, with John Coles & Co.

---

<sup>1</sup> The degree of B.E., Bachelor of Engineering, is at present given at the end of the fourth year of the Engineering Courses in Washington University. Since this chapter was prepared for the press, Mr. Boyle has taken the full professional degree of "Mining Engineer."

- Claude N. Comstock, Senior Class, Civil Engineering, Columbia College, N. Y.  
Geo. D. Eaton, Assistant, High School, Marine, Ill.  
Alfred C. Einstein, Stenographer, St. Louis & San Francisco Railway.  
Hamilton R. Gamble, Clerk wholesale Drug-store.  
Charles D. Grayson, Practical Mailer, St. Louis.  
Geo. N. Hinchman, Jr., Draughtsman in Office of Patent-Lawyer.  
Ernest C. Klipstein, Draughtsman, Real Estate Office.  
Charles A. Langdon, Clerk.  
James L. Marks, Machinist, Shops Mo. Pac. Ry., St. Louis.  
Constant Mathey, Salesman with Mermod, Jaccard & Co.  
Alexander D. Mermod, Ranchman, Poncha Park, Col.  
Ralph H. Miller, Superintendent, Toledo Manual Training School, Toledo, O.  
George S. Mills, Teacher of Drawing, Toledo Manual Training School.  
William O'Keefe, Shipping Clerk of Machinery.  
Otto H. Olfe, Draughtsman and Superintendent, with W. E. Bent, Architect, St. Louis.  
Harry M. Pflager, Head Draughtsman, Pullman Car Works, St. Louis.  
John H. Pope, Senior Class in Civil Engineering, Washington University.  
Edward L. Pretorious, Clerk, Business Department *Westliche Post*, St. Louis.  
Wm. F. Richards, Clerk in Office of Vandalia Railroad.  
Harry C. Scott, Clerk in Railroad Office.  
Percy S. Silver, Manufacturer, Lexington, Mo.  
Charles F. Springer, Merchant, Chicago.  
H. Reed Stanford, Senior Class, Civil Engineering, Washington University.  
Homer Wise, Foreman, Collier Lead and Oil Works, St. Louis.  
Edmund H. Wuerpel, Student of Drawing and Architecture.  
Harry B. Wyeth, Junior Class, Michigan University.

*Class of 1885.*

- Wm. F. Barnes, Teacher Manual Training School, Eau Claire, Wis.  
Hatcher Bates, Farmer, Mo.  
A. M. Bumann, Teacher Manual Training, Omaha High School, Neb.  
King Charles Barton, Assistant, Smelting and Refining Works, Omaha, Neb.  
Judson S. Bemis, with Bemis Brothers Bag Co.  
Edgar L. Brother, Teacher Manual Training, Swathmore College, Penn.  
Thomas W. Booth, St. Louis, Law Student.  
Albert H. Buck, Draughtsman, American Brake Co., St. Louis.  
Edward H. Chapman, Farmer.  
Frederick A. Chouteau, Teacher Manual Training, Swathmore College, Penn.  
Geo. W. Danforth, Cadet U. S. Naval Academy, Annapolis.  
H. G. Ellis, Assayer, Gunnison, Col.  
Arthur Feickert, Baker, Belleville, Ill.  
Charles O. Fischer, Office of Civil Engineer.  
Wm. F. Hopper, Apprentice, Stove and Machine Pattern-making, St. Louis.  
Clarence H. Howard, General Foreman, Motive Power, Mo. Pac. Ry.

H. F. S. Kleinschmidt, in charge of Manual Training School, Denver University, Denver, Col.  
 Albert Koberle, Student, Junior Class, Washington University.  
 Wm. P. Laing, Machinist, St. Louis.  
 Edward L. Lange, Clerk, Hardware Store.  
 Ernest E. Lazar, Machinist, Baldrige Type Writing Co.  
 Louis D. Lawnin, Clerk, N. O. Nelson Manufacturing Co.  
 Edward H. Lebens, Student, Junior Class, Washington University.  
 John J. Lichter, Jr., Student, Junior Class, Washington University.  
 Wm. Alex. Magee, Practical Electrician.  
 Frank W. Morse, Foreman, Wabash Repair Shops, St. Louis.  
 Frank E. Nulsen, with Missouri Malleable Iron Foundry Co, St. Louis.  
 Geo. R. Olshausen, Student, Junior Class, Washington University.  
 Charles M. Parker, Student, Junior Class, Troy Polytechnic Institute.  
 Frank E. Reel.  
 Louis C. Rohlfig, Medical Student.  
 Edward H. Rottman, Stenographer in Hardware Store.  
 James L. Sloss, Student.  
 Edward Smith, Lumber Business.  
 Geo. M. Stedman, General Foreman, Machine and Foundry Works, Aurora, Ind.  
 J. Harrison Steedman, Student, Junior Class, Washington University.  
 Hamilton W. Stone, Bookkeeper and Draughtsman, Heating and Ventilating Co., St. Louis.  
 Wm. T. Treadway, Machinist, Mo. Pac. Shops, St. Louis.  
 Harry L. Whitman, in business with his father.  
 Charles H. Wright, Teacher of Manual Training, Denver, Col.

#### SUMMARY OF OCCUPATIONS.

STUDENTS (engineering, law, and medicine) . . . . .	25
CLERKS (in banks, railway offices, manufactories, etc.) . . . . .	23
TEACHERS (generally of manual training) . . . . .	10
DRAUGHTSMEN (with architects, manufacturers, etc.) . . . . .	9
MACHINISTS . . . . .	6
ARTISANS (pattern-maker, bricklayer, shoemaker [with power machine], molder, and electrician) . . . . .	5
FARMERS and RANCHMEN . . . . .	5
BUSINESS MEN . . . . .	4
FOREMEN (of railway shops and lead and oil works) . . . . .	4
ENGINEERS <sup>1</sup> (mechanical and civil) . . . . .	2
MANUFACTURERS . . . . .	2
BAKER . . . . .	1
UNKNOWN . . . . .	2

<sup>1</sup> The small number of engineers is due to the fact that the additional study and training necessary for an accomplished civil, mining, or mechanical engineer, extends over *four or five more years*, and there has not been time to complete such courses.

## GRADUATES OF THE CHICAGO MANUAL TRAINING SCHOOL.

I take the liberty of adding to this list an extract from the recently issued catalogue of the Chicago Manual Training School. It shows, as well as do the records just given, how sharp an appetite for severe study a student has on leaving a manual training school.

*Graduates, 1886.*

NAME.	OCCUPATION.
MORITZ WILLIAM BOEHM,	} with Crane Bros. Elevator Co. } Teacher of Drawing, Evening High School.
STUART DUNLEVY BOYNTON,	
GARY NATHAN CALKINS,	Mass. Institute of Technology.
ALLAN MONTGOMERY CLEMENT,	with Clement, Bane, & Co., Mnfrs.
CHARLES LOCKE ETHERIDGE,	Sibley College, Cornell University.
WILLIAM HENRY FAURNEY,	Chicago College of Pharmacy.
SAMUEL DOUGLAS FLOOD,	Mass. Institute of Technology.
ARTHUR DEWEY HALL,	with St. Nicholas Toy Mfg. Co.
PHILIP HARVEY,	
CHARLES WILLIAMS HAWKES,	with Crane Bros. Elevator Co.
CHARLES GILBERT HAWLEY,	Sibley College, Cornell University.
JOHN PORTER HEYWOOD,	Mass. Institute of Technology.
HARLEY SEYMOUR HIBBARD,	with W. L. B. Jenney, Architect.
SAMUEL EDWARD HITT,	Sibley College, Cornell University.
ELBRIDGE BYRON KEITH,	Beloit College.
HENRY WILLIAM KLARE,	Reedy Elevator Works.
ROBERT ALLAN LACKEY,	with Wm. Sooy Smith & Co., Civil Engrs.
JOSEPH DIXON LEWIS,	with N. K. Fairbank & Co., Mnfrs.
JAMES STUART McDONALD, Jr.,	Ass't Sup't McDonald-Lawson Mfg. Co.
CHARLES MESSER,	
WILLIAM OTIS MOODY,	
OVINGTON ROSS,	with George P. Ross, Mnfr.
ALBERT SCHEIBLE,	School of Mech. Eng., Purdue Univ.
HERMAN SCHIFFLIN,	with Fraser & Chalmers, Mnfrs.
EMIL HENRY SEEMANN,	with Frederick Seemann, Mnfr.
HENRY HEILEMAN WAIT,	Hyde Park High School.
OLIVER JOHNSON WESTCOTT,	with A. Gottlieb & Co., Civil Engineers.

MONTHLY WAGES,<sup>1</sup> OR THE PRACTICAL MEASUREMENT OF  
THEIR BREAD-WINNING AND HOME-MAKING POWER.*Class of 1883.*

Twenty-two out of twenty-nine are in business, or have been earning regular wages. The average rate of such wages according to all the answers I have received is SIXTY-EIGHT DOLLARS A MONTH.

*Class of 1884.*

The number known to me to be earning regular wages is twelve. The average rate of their wages is SEVENTY-EIGHT DOLLARS A MONTH.

*Class of 1885.*

Fourteen out of the thirty-nine of this class have been earning money at the average rate of SEVENTY DOLLARS PER MONTH.

The average ages of the three classes in July, 1886, was twenty-one, twenty, and nineteen years respectively.

## EXTRACTS FROM LETTERS.

I must quote sparingly from my long file of interesting letters. For convenience I will number them as I take them up. Before reading the extracts, please re-read the circular.

No. 1 is engaged in mechanical work.

"Too high an estimate can not be placed upon the value of the method, exactness, and confidence which the student acquires by studying and carefully working out step by step the progressive course of study and practice. . . . My parents, my employers, and I would all join in advising a young man under all circumstances to attend a manual training school."

---

<sup>1</sup> Prof. Ripper of Sheffield, England, thus speaks of the experience of one who evidently was a pupil in his manual training school. "A gentleman recently sent his son to a steel works in Sheffield on trial for a month. He had not been there long when his master set him to make a working drawing, from a sketch, for a steel casting. The boy had been taught machine drawing at school, and to his employer's astonishment, the drawing made was not only just what was wanted, but, as the manufacturer said, it was much superior to the drawings he had been in the habit of getting. This, of course, increased the value of the boy's labor at once, thanks to the instruction he received at school. And yet how few schools there are which send their pupils forth equipped in any such way.



No. 2 is himself, tho still very young, a foreman of a large system of railway shops. I quote not what he says of himself, but what he says of other boys in his employ.

“As an employer, I will say for several of the Manual Training School boys I have working for me, that *they will in one year accomplish as much as the ordinary boy* (who has not received the training the Manual Training School gives) *will in three*. For example, I have two boys working side by side, one from the school, and the other an uneducated boy; the former has been working here nine months, while the latter has been here over three years; and to-day the boy from school will do better, cleaner, neater, quicker work by far than the other boy. One boy learns the trade by imitation, while the other learns it by reason and study. The boy from the school is more precise and neat about his work, grasps a new idea more readily, looks upon new features of the business with greater intelligence, and is better able to direct others and to bear responsibilities. He has better command of language and can impart to others the ideas he wishes them to obtain. When a difficult point arises, the school boy will labor with it until he conquers it, while the other boy will study a while, then give it up. Were I to need a clerk, apprentice, or draughtsman, I would and do give the Manual Training School boys the preference, because I get much better results with less trouble.”

No. 3 is a teacher of manual training.

“I believe that the course in your school, as it was when I was there, and as I suppose it is now, was more than what it claimed to be, and accomplished all its aims, as far as I can see. I know that it opened up more than one path for a future for me, in congenial pursuits where all was blank before.”

No. 4. This is evidently a “cow-boy” of the better sort, and he writes from his ranch in Poncha Park.

“I have not regretted going to the Manual Training School, for it is helping me a good deal. The knowledge I derived in the blacksmith shop has stood me in good stead, for on the ranch we do all our own iron-work as well as wood-work. We have a blacksmith shop and do all our horse-shoeing, though we did not learn to shoe horses at the Manual Training School. I would advise any boy who does not intend taking a classical education to go to the Manual Training School. I think my parents would answer the same way. As to my employer, I don't suppose he gives it a thought one way or the other. Out here every one thinks and talks of nothing but cattle.”

No. 5 finds use for his training, tho not a mechanic.

“Every day I am required to put into use some of the knowledge or methods learned in the shops, and I think I should be utterly at sea with-

out that training. The third year, both in the schoolroom and the shops, is of course by far the most valuable, and is the culmination toward which the rest of the course tends. You can not too strongly urge upon students the necessity of the graduating year."

No. 6. A student of the class of '84, now at Lehigh University, writes that during the Sophomore year the only difference between the course in civil and that in mechanical engineering lay in the study of "surveying" by the former, and the study of the "steam engine" by the latter. He took surveying as an "extra," and the steam engine as a "regular," and was the only student in a class of eighty-one who did so. At the end of the year his general standing was *twelfth* in a total of 131 Sophomores, and *he stood first in both surveying and steam engine*. He attributes his success to his excellent preparation.

No. 7. Designer and head draughtsman, Pullman car-shops, St. Louis. I greatly prize his suggestions.

"The advantages of the school are inestimable. . . . I receive a higher rate of wages than other boys in the same establishment. I would recommend that more attention be paid [at school] to pen-shading of concave and convex, and ogee surfaces, and also to sections and details of all kinds, so that one of your graduates may go into any shop and read any working drawing; also, that they receive a few lessons in perspective."

No. 8 is from a graduate of one year ago.

"I have a better position now than young men that have been in the same shops for three years, and I receive more pay."

No. 9 is from a graduate twenty years old, who is a stenographer in the office of a railway company.

"I consider my training at the Manual Training School as being indispensable to myself, and do not see how a young man of a mechanical, mercantile, literary, or even any professional turn of mind, can consider his education completed, or be satisfied with it, without having had at least a taste of manual training. . . . In every-day life, it makes no difference what the profession or occupation of one may be, something will turn up, where the training, such as I received at the Manual Training School, will become essential to the success, advancement, and improvement of a young man."

No. 10 is from a young man in the Junior class in dynamic engineering. Of his vacation work he says:—

"During last summer I received \$2.50 per day when I was drawing and \$2.00 when I worked at the Exposition. At the latter place I was learning to put up pipe-work."

One of the most valuable results of manual training he thinks is:—

"The habit of systematic work; I mean the habit of laying a definite plan before starting upon a piece of work or action."

The mother of No. 10 and of a graduate in the last class writes, speaking of a third son who did not take the Manual Training School course: "I now think that it would have been to his advantage to have taken the course in the Manual."

No. 11 shows that tho we have no leather work in the school our training is not lost on a shoemaker of the modern sort.

"I am running a petroleum engine and a heel-trimming machine at a shoe factory. . . . I receive \$18.00 per week. . . . I consider the training I received at the Manual Training School almost indispensable; in fact, it is what gave me my present situation."

No. 12 is a young man who learned all that was to be learned in the printer's trade and then went into the counting-room of a daily newspaper. His father, the editor and proprietor, thus writes:—

"I assure you with great pleasure, that I would send as many boys to your school as I could possibly control in that respect. Judging from experience I feel satisfied the training there benefits them not only in point of general intelligence, but as to promptness, skill, and all other particular points alluded to in your circular, equally as well."

No. 13 is from another Junior student in civil engineering. He thus speaks of his vacation work and of his preparation for the university:—

"At present, rather than be idle, I am engaged running an engine on a derrick boat at 15 cents per hour. I tend to both the boiler and the engine, and have sole charge with the exception of a foreman who looks in about once a day. During the past vacation and holidays, when there was any work, I was employed by an architect to line and fill in plans and elevations, receiving \$2.50 per day. . . . As a preparatory school for the university, the course has one disadvantage in my opinion, and that is, it is too thorough and comprehensive for the Freshman year, thereby lessening the pleasure and enjoyment of its studies, while it is not advanced enough for the Sophomore class."

His employer thus writes of him:—

“A young and energetic boy has worked in my office during vacation and holidays, and his knowledge and quick perception in mechanism and drawing are wonderful. Practical knowledge is the road to success.”

No. 14 says:—

“I am employed as rodman on the White River Branch Extension of the Missouri Pacific Railroad. My wages are \$45.00 per month, and I do not know as my manual training school education places me on any better footing than other young men, except as it may have taught me to swing an axe. This is a heavily wooded country, and on construction there are a good many stakes to make and drive. I think very highly of my manual training school training. It has given me an insight into many things I never would have thought of or investigated. The only disadvantage I have found is, that when you tell people that you are a graduate, they imagine you are a competent mechanic, and are disappointed when you inform them of the facts.

“I would advise any young man to go to the school, who was going to study any branch of engineering, or who wanted to be a mechanic. I think it would be a fine thing for him, if he expected to rise in his trade.”

No. 15 is a successful teacher of manual training. His salary the present year is \$1,050. He thus writes:—

“I think my training at your school is the best I could have received, as the combination of work is such that I have received an insight into the most prominent trades; and it has placed me in a position to judge intelligently what trade I would like to follow for a livelihood. It has made me self-reliant, and I feel that I could easily learn any trade, if I should go at it in the systematic order that we followed in our school-work.”

He then proceeds to criticise our drawing, and adds:—

“My plan for drawing would be to have it more closely connected with the shop-work, and to have each scholar learn the fundamental rules of drawing, and not have the teacher do so much work for the students.”

My readers may be sure that I attach great weight to this suggestion, though there is little occasion for such criticism now. Of this young man the city school superintendent writes as follows:—

“I do not hesitate to pronounce Mr. B. manly, intelligent, prompt, precise, skillful in his work, competent to direct it, winning the confidence of his employers, and the respect of his pupils. He has far surpassed our

expectations. . . . I have believed that the manly qualities which Mr. B. seems to possess in an eminent degree have been greatly strengthened by the course of training he received in your school."

No. 16 is a boy who is employed in a brass shop and foundry. His experience is a capital illustration of the general value of our training.

"The principal part of my work is the making of wood and brass patterns and core-boxes, and keeping them in order; I also do the greater part of the drawing for the shop; but I am by no means limited to these, as, for the last three or four days of each month, I am called to help get work out, and to help Mr. Jones figure, etc. I have also done a little tool-work, such as turning, milling, hardening, and tempering cock-reamers, and taps. I also have made a few cutters for a monitor lathe. *I usually get the work that is out of the ordinary line.* . . . Since writing the above I have asked my employer his opinion [of the school training]. His answer is almost the same as mine, with the addition that the instruction received so broadens the mind, that a student's selection of an occupation is apt to be more intelligent. He says if he wanted an assistant, draughtsman, or an apprentice he would most emphatically select one from the Training School."

No. 17, who is engaged in building, heating, etc., says:—

"My prospects, present and future, are favorable, with a good bank account and *no debts*. I never enjoyed a school more, or felt more improved by one. I think the 'Training School' helped me in many ways. Before I went there, I took no interest in improvements, such as buildings, machinery, locks, drawings, etc.; but now every thing of that kind interests me."

No. 18 is manly and kind. I see in what he says a criticism of the right sort, and I am willing that my readers should see it too.

"As to my general training at the school I can say nothing less, so far as I am now able to see, than that it is proving to be of inestimable value, not only in familiar subjects, but in subjects radically new. Its advantages are in being perfectly general, and fitting for almost any occupation. I have thus far been unable to see any disadvantages. What I consider of great importance is the matter of every-day English composition; and though I do not deem our graduates deficient in this respect, yet I think that additional work might be done in that direction, to great advantage. Letters from my classmates urge me to make this remark."

No. 19 is from a student taking a literary course in a university, preliminary to the study of law. He says:—

"I find myself greatly retarded by my ignorance of the classics, especially Latin, which was not taught in the school when my class graduated."

Latin is now taught two years of the course. He adds:—

"When I entered I was rather weak, and my head was in advance of my body. The work at the school developed my body, and gave to my mind a clearer and more practical view of things. If a person intends taking an engineering course, I should advise him to go through the Manual Training School by all means. To a person intending to go into business, I think the training secured by the combination of mental and manual labor is almost invaluable. I have a brother who intends to go into business, and I expect him to apply for admission to the school this fall."

No. 20 is still a student of engineering.

"In reply to your circular of the twenty-fifth, I wish to say, that the instructions which I received at the Manual Training School have been of great benefit to me, inasmuch as I am able to judge of the quality of work which I see, as well as to do some work myself. I have never worked steadily for any one man, for the reason that there has always been work enough about the house and in the neighborhood to keep me busy during vacation.

"My work all along has been of the nature of odd jobs at carpentering. In this way I have been able to earn, on an average, \$2.00 a day for every day that I worked.

"The instructions in drawing combined with the work in the machine-shop enabled me, by the time I had finished the course, to understand the general construction of such machinery as I saw, and at the same time to form some idea of the way in which those parts which are hidden from view might be constructed. To one who desires to learn a profession in which construction is an important feature, such a course would be very beneficial; for by knowing the different methods by which an article can be made, it seems to me that he will be enabled to so do his designing as to avoid all unnecessary complications, and consequently have his designs worked easily and cheaply."

No. 21 made the dynamo that lights his house.

"My training at the Manual has given me a foundation from which to work. I have now a very nice shop in good running order; I have a four-horse power engine (which I built myself), and two lathes and a grindstone, running almost every day, while myself and brothers work in the shop. I think that every boy, no matter what calling he intends to pursue, should have some such training as we got at the Manual."

This young man adds, that unfortunately

"The average boy when he graduates from the Manual has far too good an opinion of his abilities. The public also very often overestimates the

amount of training which one gets there. They think that he is a finished mechanic."

I have no doubt such is the case. As to the conceit, I am not sure that our graduates are much better off than graduates of other schools. We try to cultivate modesty, and to show the boys the vast amount of their ignorance.

As to the estimate strangers place upon our work, that will right itself in time.

No. 22 is a student of architecture at Cornell University. He says:—

"After leaving the Training School I went to work at the bricklaying trade. I had worked at it during vacation, while attending the Training School. It took me altogether about two years to learn my trade, the regular apprenticeship being four years. I attribute the aptness with which I learned my trade to the excellent training received at the Manual Training School. During my last year at the trade I received full wages, \$4.50 per day.

"I think the course of study at the Manual Training School a splendid thing; and I would advise every young man, no matter what his occupation in after life may be, to avail himself of the opportunity of such an education, if it is in his power. It enables one to better understand the doings and workings of our scientific world, and at the same time, it brings with it an appreciation of good workmanship and skill in the use of tools."

No. 23 was a farmer's boy; now he is teaching shop-work and drawing.

"I think that I have an insight into the care, use, and abuse of tools and machinery, so that I could or would be more likely to get a position in a shop, or begin business for myself. Most of my knowledge of tools I got there at school, for I had touched not even a jack-plane before I went there. A good point is, that it gives a broader education, and makes a true feeling for honest labor and good workmanship wherever you see it."

His father adds:—

"A farmer's boy, after going through that school, can mend and make many things that would have to be taken to a machine-shop, or can see what is the matter with a machine that is out of order. Nowadays a farmer must have a good understanding of tools and machinery, we have to use so much of them. If I was going to hire a man, I would sooner have a graduate of the Manual Training School."

No. 24 is evidently well pleased with his prospects.

"My position and pay rank far above those of other young men in similar business."

No. 25. This young man is an Illinois farmer.

"I am married, and have a little boy; and if he lives, and I can afford it, he shall go through the entire course of the Manual Training School. By this you may infer what my ideas are as to the advantage of manual training over commercial or common high schools. I have been putting my money into stock and farming implements, although I have good reason to believe that I make as much or more money than my neighbors, some of whom are old and experienced farmers; not that I raise better crops or work harder; but that I have saved and am saving a good many dollars which they give to carpenters, blacksmiths, or wagon-makers, for repair-work, *which I do myself*, with the skill I obtained while at school. As soon as I move, I expect to fix me a blacksmith and carpenter shop, and increase my present incomplete set of tools, with which I expect to do all of my own and part of my neighbors' repair-work, which will be a great saving in money and time."

No. 26 is with a gas company. He began at the bottom.

"My wages are \$66.66 $\frac{2}{3}$  per month, \$800.00 per year. I consider my training at the school of the greatest benefit to me, as I think that my knowledge of tools, besides my learning in the three R's, was what helped me to get my place as inspector. I used what knowledge I had of tools to the advantage of the company, especially that of blacksmithing; but my machine-work and carpentry come in handy now and then. If I had not given satisfaction down-stairs, I would never have been up-stairs."

No. 27 is making himself valuable to the lawyers.

"In December, 1885, I commenced in the drawing room at \$5.00 a week. I worked hard to make myself valuable, and in two months and a half I received \$6.20, and very soon after that \$7.25 per week. In May, 1886, I was offered a situation with my present employers as draughtsman at \$50.00 a month, and after due consideration I accepted the same. When I informed my former employers of my intentions, they wanted to know if I would remain with them at \$50.00 a month; but I had accepted this place, so I had to refuse. My work with this firm is making all the plats for certificates, examinations, and abstracts of land-titles, as well as entering in our plat-books all the subdivisions and additions recorded in the court-house.

"I can not well compare myself or my salary with any one in the office, since I am by many years the youngest in the office, and most of our clerks are lawyers. Should I ever be fortunate enough to have a son, and be able to send him there, he shall certainly go to the Manual Training School."

I could quote much more fully and from many more, but these must suffice. The attendance in our school of younger



brothers and friends of graduates is the best commentary on our work.

It is possible that some one may think, after seeing for himself some of the fruits of manual training, that I have overstated their value; that I have colored my picture too highly. But I have tried to be fair. Often have people, who have read my reports or heard my addresses, said to me, after actually seeing the school at work, "It is much better and larger and finer than I expected." I am thus led to believe that I am not in the habit of exaggerating.

A word more. About half the boys who attend the school get less than the whole course. For a great variety of reasons they drop out. A much larger per cent of such boys become mechanics than of the graduates. I have had many excellent reports from and concerning them. But I have not kept the reports on file.

Since writing the above, I have received a letter, which is good enough to cause me to open the case once more. I give all but the formal beginning and end of the letter. The writer was a graduate in the year 1883. His record was that of a good, careful student, not brilliant, but on the contrary so slow as to cause him at times to *appear* dull. He entered this pipe-factory soon after leaving school; and one of the first things I heard about him was, that he had *invented* and *made* a new tool, by which he had been able to outstrip the old hands who had been turning for years.

No. 28. He now says:—

"My work is that of turning all kinds of fancy and common parts of the corn-cob pipe, and I am classed on my employer's books as 'head turner.' My present or recent wages per month are from \$60.00 to \$90.00, depending on the kind of work given me; while other turners draw from \$40.00 to \$65.00 per month. I hold the best position in the house, next to the foreman, and average about \$10.00 or \$20.00 a month more than men of my age in the establishment.

"My training at the Manual Training School has been of great benefit to me many times, and in many places. I have made drawings for machines, designs [for pipes], patterns, tools, and machines of different kinds. Other positions have been offered me, but as I have a mother and three sisters to care for, I preferred to stay in Washington [Mo.].

"Mr. K——, one of the managers, told me the other day, they expected to make me foreman after Jan. 1, 1887; a very good position, paying from \$125.00 to \$150.00 per month.

"I would advise any young man to attend the Manual Training School, if he wishes to be constantly employed and make good wages. If he wants to be an engineer, let him attend that school before entering the polytechnic.

"Enclosed please find Messrs. H. T. & Co.'s answer to question six."

The letter from the firm, addressed to him, is entire as follows:—

DEAR SIR, — With pleasure we answer question six of circular submitted to us by you.

Your position you owe to your training at the Manual Training School. Our oft-repeated consultation regarding new shapes or styles of goods would show that your "ability to understand what is new" was duly appreciated by this firm.

Yes, if all the graduates of the Manual Training School showed such intelligence, promptness, and precision as we found in you, we would certainly give such graduates a preference.

Respectfully yours,

[Signed]

H. T. & Co.

Will some one complain that these young men have no high ideals? that they do not quote classic examples of patriotism and devotion to lofty aims and high arts? Will it be asserted that their ideas of life are unpoetic, materialistic, limited to good wages and methods of "getting on" in the world? If so, I shall say in reply, I am willing to trust the future for evidence of right and noble living. My confidence would be less, if they talked more about it.

I claim (and this is what this chapter is written for) that these young men are well fitted to exhibit in their lives the fruits of a good beginning in education.

What are these fruits? A writer in the *Century* for June, 1887,<sup>1</sup> gives them thus:—

"To think; to reason; to feel nobly; to see the relations of things; to put the ages together in their grand progress; to trace causes; to prophesy results; to discern the sources of power; to find true beginnings instead of unknowable causes; to perceive the moral as governing the intellectual, and

---

<sup>1</sup> T. T. MUNGER, on Education and Social Progress.

both as dominating the material; to discern the lines along which humanity is moving, and distinguish them from the eddies of the day, — such is the end of education.”

The statement suits me as well as it can him, tho he is perhaps thinking of ancient history more than I am. I am thinking of the present and its demands; of these young men as future leaders, workers, advisers, and promoters of good society and good citizenship and good government; and I do not hesitate to trust them.

The art of feeling nobly cometh not with observation. As a star is often best seen when we are not looking full at it, so a high standard in lofty matters is often best reached through high standards in ordinary matters.

Finally, I protest against that false logic which contends on the one hand, that, because the old system of education admitted no utilitarian motives, all its fruits must be noble; and on the other, that, because the new education recognizes utility as a legitimate end, all its fruits must be ignoble.

## CHAPTER VI.

WHAT OTHERS WHO HAVE SEEN IT SAY OF THE  
RESULTS OF MANUAL TRAINING.

THE author is aware that he is not writing for those who are familiar with the working of a manual training school. He knows, also, that the success of his school has often been attributed to exceptionally good material in the pupils, to superior teachers, and to the "contagious enthusiasm" of its director. Its failure under other conditions has often been predicted. It would be strange, indeed, if, when other schools exhibit so many failures, it too did not occasionally fail.

The St. Louis Manual Training School was organized as such. It had had no experience as an ordinary academy. It does not have two records which can be compared. Let me then turn to other witnesses, to other schools, and to other teachers for testimony as to the effect of manual training when incorporated with high schools, and under the charge of other teachers and directors. I do not quote from theorizers; I quote from observers, and I take them quite at random.

The first I cut from the *Journal of Education* of March 31, 1887, in its report of the superintendents' convention in Washington, D.C., during the same month. The italics are mine.

"H. W. Compton, superintendent of schools of Toledo, O., entered upon the discussion extemporaneously. He outlined what is being done in the city of Toledo in manual training, and bore testimony to the enthusiasm and earnestness of the pupils receiving instruction in manual training. The boys have done their shop-work and daily mental school-work generally with eminent success. The departments are all well sustained, especially that of domestic economy. *Manual training has increased the attendance, in the high school of Toledo fully one-third.* It is an invaluable factor in the public schools of Toledo to promote industry. Pupils love the work; it

cures idleness, dignifies and exalts labor as well as thought-power. It stimulates habits of observation and investigation."

Under date of March 31, 1887, the superintendent of manual training in the Toledo High School, Mr. R. H. Miller, writes me:—

"Our girls are doing splendid work; their mechanical drawing is neater and if any thing better than that of the boys. . . . We find that the work done by our girls (from drawings) in carpentry and wood-carving assists them wonderfully in drawing, and gives them a degree of confidence that those who simply draw do not get."

I have repeatedly said, that drawing without shop-work loses half its value; and so shop-work without drawing is educationally inferior. Mr. Miller continues:—

"It is expected that the manual-training pupils [i.e. those high-school pupils who *elect* manual training] will carry off all the honors next June. The interest of the pupils seems to steadily increase as they get deeper into the work, and handle more complicated machinery. Our boys seem to think it their duty to make life a burden to any one who speaks a disrespectful word regarding the Manual Training School. The most severe punishment we can inflict upon a pupil is to require him to sit in the high school, and study during his shop and drawing hours. We watch the pupils closely, and when one falls a little low in his average we cut off his manual work for a few days, or until he redeems himself; this seldom fails to bring him to the required standard in short order."

The German teacher of the Toledo school wrote me last year that the manual work had had such a stimulating effect upon the pupils, that he could easily tell, from the high quality of their work in German, which of his class took manual training.

Prof. J. M. Ordway, speaking of the observed influence of manual training in the Tulane High School, New Orleans, says:—

"But even with the present imperfect development, the indications are, that it tends to awaken and keep up the interest of pupils in all the school exercises; for by it they acquire juster ideas of the relation between books and actual things. They see that the school is a place for real, earnest work. They gain the habit of close attention to whatever is to be done. They learn to be patient and exact in the performance of tasks. They find that they have power to do something of themselves, and hence are likely

to acquire a manly self-reliance. They do not lose time which ought to be devoted to intellectual studies; for it is found, that, without over-exertion, they accomplish quite as much in these studies as they did before hand-work was introduced. They gain by alternating hand-work with pure brain-work, and thus resting without being idle. The surplus activity of youth, which is too prone to vent itself in mischief, is allowed to find scope in useful and pleasant employment."

Prof. Kuno Franke of Harvard University recently wrote as follows in a letter to a German paper:—

"Since the days of Rousseau, the effort to educate the rising generation in a more harmonious way than is possible in a school which aims only at the acquisition of mere scholarship has never been abandoned. The emphasis which the followers of Basedow laid upon the gain of *useful* knowledge; the thought of Pestalozzi, that the first step in education consists in the schooling of the will, while mental discipline must be treated as something secondary; Father John's gymnastics; Froebel's successful attempt to develop reason through the cultivation of the senses; and, finally, the measures which have led to the establishment and growth of the polytechnic school,—all these manifestations are still only symptoms of the one fundamental idea, that education must be directed, not to know, but to be able to do, not to words, but to deeds.

"It appears to me that *nowhere yet has this idea reached such a methodical expression as in the Manual Training School of St. Louis*: which, unlike our German trade schools (in which only one craft or occupation is taught to artisans), appeals to the whole community, and aims at general pedagogical objects.

"At a recent visit to St. Louis, I convinced myself personally of the flourishing condition of the institution. In the turning division to which I was first led, the instruction had just begun. The teacher manufactured a wooden cylinder before the class, giving at the same time the necessary explanation of the proportions of the object to be made, and the methods of handling the tools. The pupils were encouraged to ask for further information by willing answers. Then the pupils began work, each at a separate lathe. . . . Subsequently I witnessed the English instruction. The class was just reading *As You Like It*. The pupils interpreted the context and language in a thoroughly scientific manner. . . . I was sorry to find, on returning to the shop, that the closing hour had come; and I could see little more than a gay group of lads, with faces and hands soiled at the forge, with singing and jokes, washing and preparing for lunch. Still I could enjoy the impression of health and vigor which every thing possessed which I saw in the institution.<sup>1</sup>

---

<sup>1</sup> In the face of this testimony of an actual observer, a recent remark by the editor of *The Illinois Teacher*, in his issue for April, 1887, reads strangely

"The majority of the graduates turn naturally to the technical occupations; but not a few, and their number is constantly increasing, go into the law, medicine, philology, or natural science. And it does not seem improbable to me that just these will draw special profit from the education gained here. Perhaps nowhere is there greater danger of losing the foundation of clear observation and sound reasoning than where the objects of investigation are either themselves of an intellectual nature, or are only conceived of in a frame of hypothesis. It is just this danger which, above all, this school aims to avoid. He who has learned to use his hands systematically has now a clearer conception between thought and fact, between theory and practice; and this clearer knowledge will enable him to form more correct judgments in those two great spheres of observation, the real and the ideal, than is possible for one whose power of observation has been cultivated exclusively in ideal things."

I commend these observations and reflections of Prof. Franke to the thoughtful consideration of my readers.

A visitor, who writes over the name of Mortimer Warren, says:—

"The difference between the ordinary, stupid, dirty mechanic's apprentice and one of these intelligent, handy, clean, gentlemanly lads is as that between night and day."

Mr. L. E. Holden of Cleveland, O., thus wrote in the "Cleveland Herald":—

"I have been particularly impressed by my recent visit to Washington University in St. Louis, and especially with the department of manual training. I cannot go through with all the details of the shops and work-rooms, but I will give one lesson to which I listened, that you may see how great an improvement in the practical arts this manual training has over the ordinary schoolroom. [He then describes the lesson in "molding."] I was particularly impressed with the attention which *every boy gave*. Passing on to another room, a higher class were putting together a steam engine, every part of which had been made by the boys themselves.

"Now it must not be thought that these boys were neglecting their studies, or rather their books, for they were not. They were giving very close attention to the same class of studies as are pursued in ordinary [high]

---

enough. He says, in substance, that it is quite possible that, for a time, it may be found practicable to employ a boy's time for play in some sort of "useful" work; but that in the end it will be seen that "all work and no play makes Jack a dull boy." Evidently he thinks a manual training school a "dull" school as compared with the old style. Of course he has never visited a manual school, and he has no proper conception of its bright, happy, stimulating atmosphere.

schools, and from personal observation I am convinced that they are as far advanced at the same age as boys in our graded schools who are learning nothing except what they get from books.

“ . . . Now, then, let us see which class of boys would go out into the world at the age of eighteen or twenty years with the best prospects for life and good-citizenship. No one can doubt that the boy who is most practically trained would have by far the better chance for life. If we review the lives of the leading men of our country, in business, in profession, and in statesmanship, is it not strictly true that a very large majority have been boys who in early life learned to work with their hands; who had virtually the advantage of a manual training, which gave them superior advantages in physical force, in a knowledge of practical things; in short, in all that goes to the making up of a stanch manhood?”

Col. Augustus Jacobson of Chicago, who has been a frequent visitor to the St. Louis school,<sup>1</sup> writes thus to a Cleveland paper:—

“ The parent who sees a manual training school in operation sees solved before his eyes the problem how his boy may be sure to make a good living in the world. . . . To the extent of the number of the graduates of the Manual Training School, the nation is sure of intelligent and valuable citizens. When these boys enter active life they will not need to wait for ‘something to turn up,’ because they will be able to turn up something for themselves. If all our boys were so trained, we need give ourselves no anxiety for the future.”

In the preface of his admirable book on “Manual Training,”<sup>2</sup> Mr. Ham of Chicago says:—

“ In 1880 my attention was drawn to the manual training department of the Washington University of St. Louis. In that school I found the realization of Bacon’s aphorism, ‘Education is the cultivation of a just and legitimate familiarity betwixt the mind and things.’ I made an exhaustive study of the methods of the St. Louis school, and reached the conclusion that the philosopher’s stone in education had been discovered.”

Some allowance must be made for the enthusiasm of a student, but too much can scarcely be said of Mr. Ham’s efficient service in making manual training known to the people of Chicago.

---

<sup>1</sup> Col. Jacobson was the first to call attention of Chicago to our school, and to resolve that Chicago should have a similar one. Tho he found a score of able assistants in the enterprise, it is not too much to say that Augustus Jacobson was the father of the Chicago Manual Training School.

<sup>2</sup> Manual Training, by Charles H. Ham. Harper Brothers. 1886.



Henry M. James, Esq., the superintendent of the schools of Omaha, Neb., where manual training has been introduced as an elective course in the high school, says, in his last report:—

“The course has been optional, those taking it doing the same academic work as the rest of the school. Arranged in classes of twenty each, they have spent one and one-half hours daily in the shop under the care of a competent instructor, learning light carpentry and how to use and take care of tools. The teacher has been enthusiastic, and the interest of the boys has been lively and well sustained.

“It is evident that manual training schools can not be conducted without considerable expense, but for this year our shop has not cost more than some of the regular studies of the high school. It seems evident, also, that a department of this kind has a tendency to hold boys in school at a time when there is a strong inclination to leave and go into business. Our high school and eighth grade have felt this [inclination to leave], and suffered from it as much as any school in the land; yet of the seventy-nine boys who took manual training last year, *seventy-five remained in school to the close of the year.* This is a remarkable fact in the history of the Omaha schools.”

Speaking of his recent visit to the Philadelphia Manual Training School, the accomplished editor of the *Journal of Education*, Dr. A. E. Winship of Boston, says:—

“In neatness, in discipline, in perfection of execution, in balancing and blending activities, the school leaves little to be desired. The work is so systematic, its results so definite, *its effect upon the mind, hand, and character* so marked, that all objectors will do well to visit this institution, and take the time to study its working before making up their verdict.”

After nearly a year's observation of the work and influence of the Toledo Manual Training School, Superintendent Dowd, now of Toronto, says:—

“It is certainly true that the training of a manual training school *lets in a flood of light upon a thousand things but imperfectly understood before.*”

Mr. E. R. Boyer of Central Illinois, a successful teacher and superintendent of several years' experience, recently spent two months in a manual training school, studying its methods, and acquiring a practical knowledge of its drawing and shop-work. He gives the following statement of his observation of the character and influence of its work:—

“In no schoolroom have I ever seen more respectful, courteous, and gentlemanly deportment by the boys than I met in the shops of the manual training school. Whether at the work-bench, forge, lathe, or at their books, the boys are prompt, attentive, and industrious; ready to make an honest effort and eager to excel. In the shops, system, order, and thoroughness characterize the work. No hap-hazard use of tools and materials is allowed; the boy, while learning the use of certain tools, and acquiring skill with the same, is also held accountable to the instructor for the immediate product of his labor and material.

“It seems to me that this school tends to foster a due appreciation of the dignity of *intelligent* labor, and leads the boy to recognize, appreciate, and respect, skill and efficiency in the mechanical occupations; and that the school is accomplishing in a very large measure its chief purpose,—that of developing simultaneously the intellectual and physical powers of the boys under its charge.”

The prospectus of the Cleveland Manual Training School, opened in 1886, says:—

“In February, 1885, a small carpenter shop was started in a *barn* situated on Kennard Street, near Euclid Avenue, for the benefit of some boys, then pupils in the Central High School.

“Through the diligence and enthusiasm of those boys, the little school and the value of manual training was brought to the notice of some of the business men of this city.”

The Cleveland school was organized by Mr. Newton M. Anderson, who is still in charge of it in its new, well-appointed quarters, in immediate connection with the high school.

After several years of the most intimate knowledge of the work of the Mechanic Art School connected with the Massachusetts Institute of Technology of Boston, Prof. J. D. Runkle comes to these conclusions:—

“While the training of the mental faculties must always be the first and distinct aim of all education, still this training is most effective when all the senses are most fully brought into play as factors in the general process.

“We believe that hand instruction, no matter of what kind, if adapted to the age of the pupil, and properly conducted, can be made disciplinary, and a valuable adjunct to the purely literary studies.”

Mr. James A. Page of Boston, principal of the Dwight Grammar School, in which manual training was tried in 1882, thus reports:—

“From the beginning to the close the school went on with unbroken and successful regularity. The teacher was promptly on hand, the order was good, the pupils interested. It was delightful to see the eager desire manifested everywhere in the room to do the day’s work well. There was no absence, no tardiness. . . . I consider that the results go far to prove that manual training is so great a relief to the iteration of school-work that it is a positive benefit, rather than a detriment, to the course of the other studies. . . . I have a conviction that this instruction is surely in the line of the teaching that is to be. . . . There are high authorities who believe that there can be no thoroughly clear, vigorous, and enlightened brain without the cultivated hand.”

Prof. Ripper, superintendent of what is practically a manual training school in Sheffield, Eng., thus modestly speaks of the result of his observations upon the effect of manual training. When he says that such and such things *will* result, it should be remembered that he speaks from a definite knowledge of what *has been* effected under his own eyes. I quote from a recent address:—

“Hitherto we have been endeavoring to train the intelligence of the children by attempting an early development of the power of abstract reasoning, and by cramming their little minds with unintelligible facts; the object being often, not so much to educate, as to pass a certain number at the annual examination. The contrast between such a system for young children, and the more natural system of drawing out the intelligence through the exercise of the hand and the eye, as in the kindergarten method, is sufficient to make one wonder that we have been content to plod on in the old method so long.

“But in what way will manual training improve this condition of things? In this way. It will provide the connecting link between the theory of the school and the practice of the workshops, between books and tools, and between abstract rules and phrases and the reality of things. It will teach the dignity of labor by example rather than by precept. It will help to form industrious, useful habits early in life, and give a taste for doing useful work with the hands, which thousands never acquire. It will be a valuable relief from the sedentary, inactive life of the school, and so counteract the present tendency to develop a race of dyspeptic, pale-faced children, whose goal is passing examinations, and whose ambition is to be somebody’s bookkeeper. It will cultivate a respect for the worker, and an appreciation of the worth of his work, by direct personal contact with it, whereby it will be discovered how much there is to learn in order to acquire the power possessed by the skilled handicraftsman. In addition to this, it will provide the boys with a positive power to work in wood and metals with more or

less precision, which will be a valuable aid to many a lad who is destined afterwards to be thrown on his own resources in our large towns and cities, or in some of our far-off colonies."

Mr. John F. Moss was associated with Prof. Ripper in charge of the Sheffield school. Speaking at the London Conference in 1884, of the effect of combined manual and mental training, he said:—

"Those who are thus trained will start in the world with a very distinct advantage, with grander conceptions of the dignity of labor, fuller appreciation of the duties of citizenship, and brighter prospects of useful careers than could possibly be theirs without such aid."

Mr. E. M. Dixon, the principal of Allan Glen's Institution, which is really a manual training school at Glasgow, Scotland,<sup>1</sup> says, after an experience of several years:—

"Our experience seems to have proved that lads of fifteen or sixteen can acquire in two years, during which they spend not more than one-half day weekly in the workshop, at least as much manual skill as is usually acquired by lads in the first two years of an ordinary apprenticeship."

Again he says:—

"Our experience being, that a systematic course of instruction in drawing, combined with suitable workshop exercises, is, in almost every case, capable of turning out a lad at sixteen years of age able to interpret and execute technical drawings of even considerable complication, it is desirable that practical men should know the fact as widely as possible, and also the means whereby it may be realized. . . . I believe, that, in the case of many pupils in whom the faculty of abstract thought is but moderately developed, and by whom the theoretical subjects of instruction are consequently apt to be somewhat feebly grasped, the experiences of the workshop are, or may be, all-important in the way of throwing light upon results that the pupil fails to trace as deductions from more remote principles, but which he can, of course, accept as facts of direct experience. I am not sure, that, even to the most subtile-minded, the manifold experience that a moderate amount of systematic workshop practice supplies may not have a very beneficial effect in the way of securing perfect confidence in much of the theoretical instruction received in the lecture room."—*Report of International Conference on Education at London, 1884, vol. ii.*

In this last paragraph, Mr. Dixon covers the whole ground.

---

<sup>1</sup> I visited this school in April, 1885, and was delighted to find both teachers and pupils enthusiastically engaged on an admirable program.

Prof. R. H. Thurston, director of Sibley College, Cornell University, says:—

“It is marvelous to see how rapidly boys acquire the power of skillfully using tools. . . . I believe that nineteen boys out of twenty do possess more or less of the mechanic’s tastes and powers; and that the other one out of the twenty will be so benefited, and his usefulness to himself and the world so increased, by shop instruction, that he will do well to secure it. But in the work of life a man must do that for which he is best fitted, and he can not hope to succeed in competition with the world if he attempts to make a livelihood and to carry on a business for which he is not fitted. The turtle may be an admirable diver, but he can not hope to succeed in the race with the hare — if the hare attends to his business.”

In the last chapter, I quoted from a letter of Mr. Ralph H. Miller, the superintendent of the Scott Manual Training School, which forms the complement of the Toledo high school. He was No. 3 on my list. Since he wrote, the school-year has closed, and in the *Toledo Blade* I find some comments which are appropriate to this discussion. Speaking of the graduating students, the *Blade* says:—

“One remarkable fact is that so many who won honors were students in the Manual Training School. It demonstrates that the manual training department of the Toledo high school is all that is claimed for it. Another fact which proves the efficacy of the manual training is that so many boys remained in the class. More boys graduated this year than ever before in the history of the school.”

The roll shows eighteen boys and twenty girls. Among the “honor” pupils are mentioned two young ladies whose choice of occupation is somewhat unusual, and plainly the consequence of their manual training.

“Miss Jessie Platt has been a pupil in the Manual Training School for three years, and averaged the highest in her class for the high school course for three years, and has not been absent or tardy for five years. She will devote her attention in the future to architecture.

“Miss Minnie Hales has taken the manual training course for three years, and will hereafter devote her attention to architectural drawing. She will take a post-graduate course in the manual training school next year. . . .

“The interest taken by parents in the work of their children is best shown in the attendance this afternoon. The inspection is one series of surprises.

The advancement made by the pupils, as they work from one grade to another, is so well shown, and so easily seen, that fathers and mothers can scarcely believe it."

To the question: does not the intellectual work suffer if time is taken for industrial work in school, Miss May Mackintosh, a teacher experienced in manual work, replies:—

"The answer is emphatically No! Children, especially young children, can not force their attention to keep to one subject for long together,—the actual time varying with the children and the personal influence of the teacher,—and it is hurtful to them, physically, mentally, and morally, to be obliged to take part in any lesson after this period of fatigue is reached,—intellectually, because they form the habit of inattention and self-defence; morally, because they are obliged to pretend attention; and physically, in their poor little restless bodies, that need so much movement for their healthy development. Then what a blessed relief is some piece of work for the hands, and how fresh the interest and attention for the following studies. It is the most economic arrangement, even if the claims of intellectual education are considered as paramount."—*Education*.

Prof. Felix Adler, who has now had eight years of experience in the conduct of a manual training school for the grades from the kindergarten to the high school, says in a recent report:—

"How does it come to pass that those two organs, the eye and the hand, which are the preferred messengers for carrying out the intentions of mind, should receive so little discipline? . . . Who will deny that the future physician, the experimenter in every department of science, and indeed every one to whom a deft hand and keen powers of observation are important, will find such a preparatory discipline in early youth an inestimable advantage? . . . While the pupil is shaping the typical objects which the instructor proposes to him as a task, while he pores silently, persistently, and lovingly over these objects, reaching success by dint of gradual approximation, he is at the same time shaping his own character, and a tendency of mind is created from which will eventually result the loftiest and purest morality."

But perhaps the most striking testimony comes from England. The report of the Royal Commissioners, already referred to, had called attention to the conditions of technical success in America and elsewhere, and the character of our manual training was fully given by Mr. William Mather, who repre-

sented the Commission in the examination of American schools. It was my privilege to contribute a paper on "Manual Training Schools" to the International Conference on Education at London in 1884, and by special invitation to read an address on "Manual Training in General Education" at a conference at Manchester in April, 1885. As a result of three public discussions of the subject, during which the details of the St. Louis school were fully given, the Board of Managers of the Manchester Technical School converted it both in name and in fact into a manual training school. In all discussions touching this subject, William Mather, Esq., was prominent; and having entered Parliament the following year, as the member from Salford, he voiced the public interest in the new education by giving formal public notice of the following motion:—

"That in the opinion of this House, in view of the increasing competition of foreign nations with our manufactories both at home and abroad, it is necessary to extend our national system of education in order to bring the teaching of the natural sciences, manual training, and technical instruction within the reach of the working classes of this country."

The vice-president of the Council of Education, the Right Honorable Sir Lyon Playfair, in bringing his estimates before the House for the annual grant for public education, said that Mr. Mather's motion had his cordial approval, and he looked forward to the time when this comprehensive proposal would receive the sanction of Parliament.

A day was set when Mr. Mather should fully discuss his motion before the House; but, unfortunately, before that day arrived, the Liberal Government was overthrown and Parliament was dissolved.

'But interest in the subject is on the increase, and beyond question great progress will soon be made. I learn from Mr. Mather, that one form taken by the Jubilee celebrations consists in promoting the establishment of manual training schools. I look with confidence to an early modification of the "Code" which shall recognize systematic manual training as legitimate educational work.

The English movement, as well as the American movement, as has been truly said by my enthusiastic and versatile friend, Rev. E. P. Powell of Utica, N.Y., is not so much an evolution, as a revolution, in public education.

And now comes the announcement at the last moment (June 1, 1887) that the London School Board, on motion of the Rev. Charles Lawrence, has resolved by thirty-one votes to six, "that in the opinion of this Board it is necessary to introduce into schools some regular system of manual training."



## CHAPTER VII.

THE COMPLEMENTARY NATURE OF MANUAL TRAINING.<sup>1</sup>

WITH his gentle lance Emerson pricked many a bubble; and, though collapse did not always follow immediately, the wound was always fatal. In 1844, in his essay on New England reformers, he charged popular education with a want of truth and nature. He complained that an education to *things* was not given. Said he, "We are students of words; we are shut up in schools and colleges and recitation rooms for ten or fifteen years, and come out at last with a bag of wind, a memory of words, and do not know a thing. We can not use our hands or our legs or our eyes or our arms." And again, speaking of the exclusive devotion of the schools to Latin, Greek, and mathematics, "which, by a wonderful drowsiness of usage," had been "stereotyped education, as the manner of men is," he says, "In a hundred high schools and colleges this warfare against common-sense still goes on. . . . Is it not absurd that the whole liberal talent of this country should be directed in its best years on studies that lead to nothing?"<sup>2</sup>

---

<sup>1</sup> An address delivered at Saratoga, N.Y., on Thursday, July 13, 1882, before a joint meeting of the National Teachers' Association, and the American Institute of Instruction.

<sup>2</sup> "The College [Harvard] fitted us for this active, bustling, hard-hitting, many-tongued world, caring nothing for authority and little for the past, but full of its living thought and living issues, in dealing with which there was no man who did not stand in pressing and constant need of every possible preparation as respects knowledge and exactitude and thoroughness, — the poor old college prepared us to play our parts in this world by compelling us, directly and indirectly, to devote the best part of our school lives to acquiring a confessedly superficial knowledge of two dead languages!" — CHARLES FRANCIS ADAMS, JR., *A College Fetich*, 1883.

Similarly Mr. George S. Merriam, a graduate of Yale, speaks of the time spent

This is, perhaps, too severe, but we must admit that Emerson anticipated and greatly aided a reform which has been gathering strength for a whole generation. Hence it is to-day scarcely necessary that I should present arguments in favor of manual education. The great tidal-wave of conviction is sweeping over our whole land, and the attitude and aspect of men are greatly changed from what they were ten years ago. What I said in 1873 in a public address in favor of technical education was held to be rank heresy. I fear it would be regarded as rather commonplace to-day. The progressive spirit of the age has actually penetrated our thick hides, and we are trying to keep step with the universe.

To be sure, we still call ourselves reformers, and we shall continue to battle for the new and true till our banners are the only ones flying. But the day of surrender is near at hand. One by one the outposts have fallen into our hands, and only a few citadels remain. An armistice has been asked for; and, if we can only arrange satisfactorily the terms of an honorable capitulation, the enemy is willing to march out and join our ranks.

In every community the demands of technical education have been discussed, and in every instance when the old system has been subjected to the tests which good sense applies to business, it has been found wanting.

And yet let me not pass with only words of criticism. Let us recognize the inestimable value of American public educa-

---

in the study of words: "Up to the day when I took my diploma, there had been, I may say, nothing in my education that required me to use my eyes, or any of my senses or perceptions, for any purpose save to read the printed page. I had been taught no knowledge, and no means of acquiring knowledge, except from books. Of knowledge at first hand, I had learned absolutely nothing. . . . The whole habit of personal observation of the phenomena and processes of the material world was left out of our education entirely. That omission for myself I unspeakably lament. History and literature I can to some extent pick up as I go along; but I shall never get that intelligent, sympathetic, working knowledge of my physical environment for which the aptitude and instinct might have been easily gained when I was fourteen or sixteen. . . . I was given, indeed, some of the keys to the liches of literature, but of *things* I never learned the alphabet. I acquired no use of my perceptions save with my eyes to read the printed page, and with my ears to hear my instructor's voice." — *Address to Yale Alumni in 1883, as quoted by Mr. Adams.*

tion. With all its faults, it is our best inheritance. Let us be just, yea generous if need be, to the bridge that has brought us over. Let us say, "God speed your work!" to those who are battling for education in States black with illiteracy, and let us commend the splendid work done by earnest men and women on all sides. But the faults—we must not be blind to them. If the old education has been good, we can make the new better.

#### DEFECTIVE EDUCATION.

Is, then, I ask—is the education we give as broad and round and full as it ought to be? Is the time of tutelage most wisely spent? Do the results we secure justify the means and methods we use? Is the relation between education and morality as close as it should be? I think to these questions we must seriously answer, No! There is a lack of harmony between the schoolhouse and the busy world that surrounds it. Some have even claimed that we are wrong in supposing that education always diminishes crime. Let us see if there is any truth in their position.

You know how often a life is a failure from defective education. Too often do we see young people, who might have been educated to eminent usefulness, cast —

“unfinished”

Into this breathing world, scarce half made up.”

I have seen poor lawyers, who, under a proper system of training, would have made excellent mechanics, and not a few of highly educated, able-bodied men, actually begging for the price of a day's board. I recall one man in particular who was able to speak several languages, but because no one would employ him as a linguist he must needs beg, for he knew not how to work. Now, when a man's education has been misdirected, and he is thrown upon the world, shackled by out-grown theories, bewildered by false lights, and altogether unprepared for the work which perhaps he was born to do, and when in his extremity he resorts to knavery and violence and fraud to secure what he knows not how to get by fair means, those who directed or should have directed his education can not be held blameless.

The moral influence of occupation is very great. A sphere of labor congenial and absorbing, that fully occupies one's thoughts and energies, is a strong safeguard of morality. If you would keep men out of mischief, keep them busy with agreeable work or harmless play. The balance of employments is fixed by our state of society and the grade of our civilization. Now, if indiscriminately we educate all our youth away from certain occupations and into certain others, as is very clearly the case, some employments will be crowded and consequently degraded: in others, the choicest positions will be filled by foreigners; and the lowest posts, wherein labor is without dignity, must perforce be filled by those who have neither taste nor fitness for their work. The result is broils, plots, and social disorder.

Thirty years ago an eloquent Frenchman (Frederic Bastiat) charged the one-sided education of his countrymen with being an actual danger to society. He argued that the "stranded graduates," as he called those who, unable to navigate the rough waters of practical life, had been tossed high and dry on the reefs along the shore, "filled with a sense that the country which had encouraged them to devote their best years to classic studies owed them a living, or a means of living, would become the leaders of mobs, and officers at the barricades."

#### MORE LIGHT.

When the shadow of death was drawn over the great Goethe, he uttered his last wish for "more light." We must echo his cry, if we would prepare our American system of education for a more glorious destiny. We treat our children too much as the unskilled gardener treats his plants. He puts them by a window and pours over them a flood of light and life-giving rays. Instinctively they turn out towards the source of their strength. They put forth their leaves and budding promises; and, as we look at them from the outside, we mark their flourishing aspect, and rejoice. But, if we look at the other side, we shall find them neglected, deficient, and deformed. What they want is more light—light on the other side. Were the

sun always in the east, our trees would all grow like those on the edge of the forest, one-sided.

So in education, we must open new windows, or rather we must level with the ground all artificial barriers, and let every luminous characteristic of modern life shine in upon our school-rooms. We must pay less heed to what the world was two or three hundred years ago, and regard with greater respect what the world is to-day. Before we devote ourselves exclusively to the arts of expression, we must cultivate all the faculties and encourage the growth of thoughts worthy of expression.

#### THE ARTS OF EXPRESSION.

Dr. Youmans recently said (*Popular Science Monthly*, May, 1882):—

“The human mind is no longer to be cultivated merely by the forms or arts of expression. The husks and shells of expression have had sufficient attention; we have now to deal with the living kernel of truth. . . . Under the old ideal of culture, a man may still be grossly ignorant of the things most interesting and now most important to know. . . . Modern knowledge is the highest and most perfected form of knowledge, and it is no longer possible to maintain that it is not also the best knowledge for that cultivation of mind and character which is the proper (i.e., the highest) object of education.”

I desire, for a moment, to direct your attention to the arts of expression. Next in rank to the ability to think deeply and clearly is the power of giving clear and full expression to our thoughts. This last can be done in various ways. As this brings me squarely upon a subject I wish to impress strongly upon you, I will illustrate it by a somewhat elaborate example.

A gentleman recently called upon me for my opinion concerning a certain automatic brake for freight-cars. The device was new to me, but it lay pretty clearly defined in the mind of my visitor. It was not original with him, but for the purposes of my illustration it might have been. Before I could pass judgment, the device must lie as clearly in my mind as it did in his, perhaps more clearly: so he set out to express his thought. He was what we call well-educated, being a graduate of the oldest university in the land, and was well versed

in the conventionalities of spoken and written languages. Accordingly he proceeded to utter a succession of sounds. His lips opened and shut with great rapidity, and without intermission a series of sounds fell upon my ears. The sounds I heard were quite familiar to me, as I had been listening to them in one order and another for over forty years; and as they had always been associated in my mind with certain concrete things, and the relations of such things to each other, certain thoughts about those things began to take shape in my mind.

Of course, the sounds I heard had not the smallest likeness to the things called up by them in my mind. To an Italian peasant, or to Archimedes of Syracuse, they would have been as unintelligible as the chattering of a magpie. They were purely arbitrary or conventional; yet much of our education had been devoted to their mastery. Nevertheless, as a means for expressing thought, they were in the present case quite inadequate. The ideas aroused in my mind were confused and fragmentary, and altogether unsatisfactory. Had my friend resorted to writing a description of the invention, in either English, French, German, Latin, or Greek, using in every case a set of purely conventional symbols (to represent other sets of conventional sounds) which we had both spent years in getting some knowledge of, he would have succeeded little better. Whether speaking or writing, much of his thought he could not clothe in words. He therefore abandoned the wholly conventional, or verbal, art of expression, and turned to the pictorial.

But here he soon confessed that his education was deficient. He had never studied the art of representing objects having three dimensions on a surface having but two, and hence he was ignorant of the methods he ought to adopt to express by drawings the objects he was thinking of. However, I caught more of his meaning from some crude attempts at sketching than I did from all his talk. A few lines were luminous, yet they left far too much for me to supply by my imagination; hence my visitor withdrew, and sent me a full set of what we called "working drawings," made by the inventor, who was a draughtsman.

These drawings, tho a sort of ocular resemblance to the things signified, were still half conventional, and required on my part a certain amount of training to enable me fully to understand them. This, fortunately, I had received; and, through the art of expression embodied in them, I gained a tolerably clear idea of the thought of the inventor. With scarce a written or spoken word, they expressed that thought far more clearly and fully than any merely verbal description could do; they showed the relations of parts which were beyond the reach of words.

But my friend was not content to stop there. The drawings had been but partially intelligible to him, with their "plans, elevations, and sections;" and, judging me by himself, he believed that a third art of expression would out-value both the others. He therefore invited me to call at a shop and examine a specimen of the device itself, produced by a skilled mechanic. The *real article*, which is the mechanic's art of expression, proved to be an improvement even upon the thought of the inventor. The latter had not been a mechanic, and he had made the sort of mistakes that draughtsmen who are not fair mechanics always make. Certain parts of the design it had been practically impossible to construct, as they involved shapes that could not be molded by ordinary means. A nut had been placed where it was next to impossible to turn it; and certain parts which were to be of cast-iron had been given such dimensions that the castings would have snapped in pieces while cooling. These errors had been corrected by the mechanic, and the perfected thought lay fully expressed before me.

In this illustration we have three greatly different methods of expressing essentially the same thought. Each constitutes a distinct language, and each is absolutely essential to modern civilization.

You will note how a crude thought often takes practical shape in the hands of the draughtsman and the mechanic. "Drawing," says Prof. Sylvanus P. Thompson, "is the very soul of true technical education, and of exact and intelligent workmanship." Those who have tested this can tell how many

marvels of ingenuity, as lovely as a *chateau en Espagne*, have vanished in the presence of "plans and elevations;" and how many beautifully drawn designs have been mercilessly condemned as impracticable by judges versed in the laws of construction and the strength of materials.

Much more could be said upon the arts of expression, their relative importance and proper cultivation. You will readily think, as did Lessing in his *Laocoön*, of poetry, painting, and sculpture. You will recall how lofty thoughts have in all ages found expression in architectural forms; and yet throughout all the history of architecture the laws of mechanics as then understood, and the properties of the materials used, have determined the different styles. In our own age we are trying to express ourselves in iron and steel, and to cast off the fetters of an age of marble and granite.

In a recent address Mr. Charles H. Ham of Chicago said, that, by putting thought into seventy-five cents' worth of ore, it is converted into pallet-arbors worth twenty-five hundred thousand dollars. He continues: "Skilled labor is embodied thought—thought that houses, feeds, and clothes mankind. The nation that applies to labor the most thought, the most intelligence (i.e., that best expresses its thought in concrete form), will rise highest in the scale of civilization, will gain most in wealth, will most surely survive the shocks of time, will live longest in history."

But some one will say, as to methods of expression, "One art is enough for me; make me master of one, and I will care for no second." I answer, you are thinking of an impossibility. If a mechanic is only a mechanic, he is never a master, even of his own art. He is crippled at every turn; he is limited in expressing himself to what he can make. He is without that powerful ally, drawing, the short-hand of the imagination; and in the presence of thoughts that baffle concrete expression he is dumb. Valuable machines even are sometimes purely imaginary. Clerk Maxwell, in his "Theory of Heat," says, "For the purposes of scientific illustration we shall describe the working of an engine of a species entirely imaginary,—one which it is impossible to construct, but very easy to understand," referring



to Carnot's engine. In like manner, if one would command confidence as a draughtsman, he must be a mechanic as well. And finally, if I am a student of words alone, and if I go not beyond my dictionaries, I shall never guess their meaning. A large proportion of our emphatic words are technical; they belonged originally to some craft, and none but a craftsman knows their exact meaning. President Eliot of Harvard once said that the highest education was that which gave one the fullest and most accurate use of his mother tongue. I would modify the statement, and claim that the highest and most liberal education is that, which, beside cultivating most fully the powers of thought, gives one full command of all the arts of expression.

I need not remark that many, perhaps most, thoughts do not admit of concrete, nor even of pictorial, expression, — as, for example, all abstractions; hence, they suffer seriously from want of clearness. If you have a clear thought on abstract matters, you can never be sure you have expressed it clearly.

The thought must precede its expression by any method, and in the cultivation of the thinking mind the concrete should precede the abstract. Give children clear and accurate thoughts of real things, of the material world we live in, of real plants and animals, of the laws of materials, of qualities and then of quantities, before you venture on the field of abstractions. Before you cultivate the high arts, make sure of the low ones: without them as a foundation, no superstructure of fine art can safely be built. As Emerson says (in *Man, the Reformer*), "We must have a basis for our higher accomplishments, our delicate entertainments of poetry and philosophy, in the work of our hands. We must have an antagonism in the tough world for all the variety of our spiritual faculties, or they will not be born."

A habit of clear thinking once formed will never leave us, however abstract our investigations become; while a habit of stopping short with ill-defined results, of resting content with obscure and half-grown mental images, of accepting a mental attitude of fogginess, has a stultifying effect which seriously dwarfs the mind. This is a most important subject, but I have

place for but a few words of exhortation. Give children clear thoughts, and begin with the concrete. When the mind is too weary or too sick to clear up obscurities, it is time to seek rest and recreation and fresh air. Beware of straining the powers of attention by too much schooling; beware of overtaxing the mind by too many and too difficult subjects; and especially beware of poisoning the blood and debilitating the brain by bad air. The fruit of any and all these evils is mental as well as physical decrepitude.

#### THE AIMS OF EDUCATION.

But to return. I claim for these forms of expression, which I have taken pains to distinguish, more nearly equal care and consideration in the elementary education of every child. Teach language and literature and mathematics with a view to make each child a master of the art of verbal expression. Teach mechanical and free drawings with the conventions of shade and color, and aim at a mastery of the art of pictorial expression. And, lastly, teach the cunning fingers the wonderful power and use of tools, and aim at nothing less than a mastery of the fundamental mechanical processes. To do all these things while the mind is gaining strength and clearness and material for thought, is the function of a manual training school.

#### PREJUDICES TO BE OVERCOME.

The traditions are heavily against us, but the traditions of the fathers must yield to the new dispensation. As was to have been expected, the strongest prejudices against this reform exist in old educational centers.

As Prest. Walker of the New York Board of Education frankly admitted at the laying of the corner-stone of Prof. Felix Adler's splendid institution, "The Workingman's School and Free Kindergarten," the methods and aims proposed by the advocates of manual training schools are a criticism upon the methods and aims of the established system, and nothing is more natural than for it to resent the criticism and discourage reform.

No man has done more — nay, no man has done as much — to introduce the manual feature into American education as Prof. John D. Runkle of Boston; and yet the School of Mechanic Arts established by him in connection with the Massachusetts Institute of Technology has, after an existence of several years, been apparently almost frozen out in the biting atmosphere of that highly æsthetic city.<sup>1</sup> I doubt if one could find on American soil a more unpromising field for a manual training school than beneath the lofty elms of Cambridge and New Haven.

#### LUXURIES IN EDUCATION.

There are luxuries in education, as in food and dress and equipage; and in wealthy communities the luxuries command the chief attention. At the English universities of Oxford and Cambridge, a large proportion of the students expect to be gentlemen of leisure. The idea of giving heed to the demands of skilled labor, of preparing for lives of activity and usefulness; the idea of earning one's daily bread, and of supporting one's family, — scarcely enters their heads. Either they inherit livings, or they seek to get livings through the Church, or they enter the army with commissions purchased by kind friends who wish to get them out of the way, or they go into law and politics. It is ~~no~~ wonder that such men devote themselves largely to the luxuries of education, Sanscrit, Latin hexameters, Italian; in a word, to "polite" learning. In such an atmosphere as that, how incongruous is the plea of mine for an education to things; for a training of the hand and eye as well as the intellect to lives of useful employment! Yet half the colleges in the United States ape the English universities, and half the high schools ape the colleges.

The result of all this has been a certain false æstheticism which turns away from the materialism of our new notions. The highly cultivated would soar away into purer air and nobler spheres. There is a feeling, more or less clearly expressed, that the material world is gross and unrefined; that soiled hands

---

<sup>1</sup> This was said five years ago. I am most happy to say that such criticism is no longer possible.

are a reproach; that the garb of a mechanic necessarily clothes a person of sordid tastes and low desires. As Dr. Eliot of St. Louis has expressed it: "It is thought to be a sad descent for a university whose aim should be the highest education to stoop to the recognition of hand-crafts of the mechanic."

#### MANUAL EDUCATION.

Perhaps no better general statement of the new creed has been made than that of Stephen A. Walker, in a speech already referred to. He put it for us thus: "Education of the hand and the eye should go along with, *pari passu*, the education of the mind. We believe in making good workmen as well as in making educated intellects. We think these are things that can be done at the same time, and our proposition is that they can be done better together than separately."

As I said in the beginning, this proposition is meeting with general favor among the people. I have pointed out the sources of some of the opposition; it remains for me to touch upon the two objections which I surmise are about the only ones in the minds of my hearers. You ask first, "Is your proposition practicable?" You doubt the feasibility of uniting in a real school such incongruous elements as arithmetic and carpentry, history and blacksmithing. You fear either that the shop-work will demoralize the school, or that the shop-work will never rise above the dignity of a mere pastime.

Now, I claim not only that what I propose can be done, but that it has been done in St. Louis, and perhaps elsewhere as well.

#### ORGANIZATION OF A MANUAL TRAINING SCHOOL.

Prof. Thompson, in his valuable essay on the apprenticeship schools of France, classifies French technical schools under four heads:—

1. The school in the workshop or factory.
2. The workshop in the school.
3. The school and the shop side by side.
4. The half-time schools.

In the first class the school is subordinate to the factory; the boys or girls learn a particular trade, and every thing in the school as well as in the shop is designed to meet the wants of those expecting to enter the particular trade. For obvious reasons there can be no general adoption of such a combination in this country. Prof. Thompson gives his verdict in favor of the school and the shop side by side, though there is much to recommend the second plan.

No one of the French plans exactly suits me. I prefer to incorporate manual with intellectual education, and include both under the name school. We don't have what you call school in the morning, and shop in the afternoon; nor do we spend the forenoons with tools, and devote a few evening hours to study and recitation: our school program combines the old and the new in just proportion.

There is no confusion, no sense of incongruity. The boys go as soberly to shop as to recitation; though I ought to add that almost without exception they delight in the use of tools, and it is no small punishment to be kept from the shop for some neglected lesson.

The Manual Training School of St. Louis differs from all other technical schools with which I am acquainted. It much resembles the Boston School of Mechanic Arts; though it differs from it in admitting boys at fourteen instead of fifteen years of age, in having a three years' course instead of two, and in having a full and independent equipment of study and recitation rooms as well as shops. I gladly avail myself of this occasion to publicly acknowledge our indebtedness to the able reports and papers published by ex-President Runkle on the Russian system of tool instruction, and the organization and work of his school.

All European schools of the same grade are more or less devoted to particular trades, excepting the school at Komatau, Bohemia, and perhaps other similar schools, where the shop-work is three times as much per day as with us, and where book-learning is crowded between very narrow limits.

In like manner, all other technical schools in this country are either devoted to single trades, or they are of a higher grade.

To those who do not care for the details, I will say that our course of study runs through three years in five parallel lines.

*First*, A course in pure mathematics.

*Second*, A course in science and applied mathematics.

*Third*, A course in language and literature.

*Fourth*, A course in penmanship and drawing.

*Fifth*, A course in tool-work in woods and metals.

Our school is not managed on the assumption that every boy who goes through it will be a mechanic, or that he will be a manufacturer. They will doubtless find their way into all the professions. We strive to help them find their true callings, and we prejudice them against none.<sup>1</sup> I have no sort of doubt, however, that the grand result will be that many who otherwise would eke out a scanty subsistence as clerks, book-keepers, salesmen, poor lawyers, murderous doctors, whining preachers, abandoned penny-a-liners, or hardened "school-keepers" will be led, through the instrumentality of our school, to positions of honor and comfort as mechanics, engineers, or manufacturers.

#### NO ARTICLES MADE FOR SALE.

For the purpose of discountenancing certain grave popular fallacies in this country, I will add a word, even at the risk of repeating what I have said elsewhere, as to our plan of shop management. We do not manufacture articles for sale, nor do we pretend to fully teach particular trades.

---

<sup>1</sup> In June, 1881, I wrote as follows to the *Chicago Tribune*: "We do not expect that all will develop into fine mechanics just because all are required to take the regular course of shop-work; neither do we expect that all will develop into fine mathematicians just because all study algebra; nor that all will acquire a faultless English style just because we lay unusual stress upon English composition and literature. The purpose of the school is to develop, to educate, as well as to train; to bring out into clear relief those very aptitudes which ought to control the destiny of the boy. What we complain of in ordinary schools is that they are one-sided, — that they draw (or drive) away from mechanical pursuits without regard to fitness. Many of our pupils will go forward through the higher courses in letters or engineering. No check is to be placed upon them. An increasing number will unquestionably be drawn to practical mechanics of some kind or degree. If every one makes a wise choice, I shall be satisfied. I am anxious only for them to choose aright. If the school (which aims impartially to be a mental and moral and manual training school) should serve no other end but that of enabling a parent to decide what to do with his son, it would still be worth all it cost."

A shop which manufactures for the market, and expects a revenue from the sale of its products, is necessarily confined to salable work, and a systematic and progressive series of exercises is practically impossible. If the shop is managed in the interest of the student, he is allowed to leave a step or a process the moment he has fairly learned it; if it is managed with a view to an income (and the school will be counted a failure if its income is wanting), the boys will be kept at what they can do best, and new lessons will be few and far between. In such a shop the pupils will suffer too much the evils of a modern apprenticeship.

“The common apprentice is a drudge set to execute all kinds of miscellaneous jobs. There is no systematic gradation in the difficulty of the exercises given him; more than half his hours are purely wasted, and the other half are spent on work unsuited to his capacity. What wonder that four, five, or six years make of him a bad, unintelligent, unskillful machine!”  
—PROF. SYLVANUS THOMPSON.

A very bright boy of seventeen years had expected last fall to enter a pattern-shop in St. Louis as an apprentice, but was disappointed, there being no vacancy in the number of apprentices allowed. He therefore came to the Manual Training School, and during the year made excellent progress, not only in carpentry and wood-turning, but in drawing, mathematics, and physics. When he showed me some of his handiwork at the end of the year, I asked him if he would have made equal progress as an apprentice? “No,” said he, “I should have spent most of the first year sweeping out offices and running errands.”<sup>1</sup>

#### SELF-SUPPORTING SCHOOLS.

I fancy there is no more pernicious fallacy than this of making a school self-supporting by manufacturing for the market. Suppose you attempt to maintain one of those popular humbugs, a commercial college, on that theory; or to run a full medical school, without endowment, on the self-supporting plan (the

---

<sup>1</sup> Since the above was written, a gentleman told me of his father's experience when learning the trade of a tanner, in Philadelphia, many years ago. He lived in the family of his employer, and during the first six months *he tended the baby*.

students would probably write prescriptions cheap, and cut off legs for half-price); or to manage a public school of oratory and English composition on the strength of an income derived from contributions to newspapers and magazines, and from orations made and delivered to order! Nothing could be more absurd, and yet the cases are closely parallel. No, do not be beguiled by the seductive promise of an income from the shop. Admit from the first the well-established fact, that a good school for thorough education on whatever subject costs money, both for its foundation and its support.

Closely connected is the matter of teaching particular trades, to which the lads shall be strictly confined. Such a course may work well in monarchies, where the groove in which one is to run is cut out for him before he is born; but it is unsuited to the soil and atmosphere of America. A single trade is educationally very narrow, while their number is legion. "The arts are few, the trades are many," says Mr. Runkle. The arts underlie all trades: therefore, let us teach the arts as impartially and thoroughly as possible, and then it is but a step to a trade.

#### BUT A STEP TO A TRADE.

And this brings me to a very important point. Admitting that with a suitable outfit of tools, shops, etc., a program such as I have described can be carried out, you ask, "*Cui bono?* What, after all, is the manual training acquired at school good for? Has the mind been nourished through the fingers' ends? Has the hand gained any enduring skill? Is it really but a step from the door of the manual training school to the shop of the craftsman?"

Experience answers all these questions satisfactorily, and adds that there is scarcely a calling in society that is not edified by manual training. Rousseau once remarked that "to know how to use one's fingers gave a superiority in every condition in life." I recently made systematic inquiry among the parents of my boys, as to the effect of the one or two year's training in our school. Their reports on the points now under consideration are both interesting and encouraging. They write:—



“Gerald takes great interest in fixing up things generally.”

“Charles fixed my sewing-machine.”

“George has made many little matters of household utility, and seems to delight in it.”

“We go to Henry to have chairs mended, shelves put up, etc., and he does excellent work. He made a fine set of screen frames.”

“The mechanical faculty was quite small in John’s case, and it has been developed to a remarkable extent.”

“Leo does all the jobs around the house;” and so on for nearly a hundred pupils.

Again, the parents testify to an increased interest in practical affairs, in shops and machinery, and in such books and periodicals as the *Scientific American*. Beyond question, there is a certain intellectual balance, a good mechanical judgment, a sort of level-headedness in practical matters, consequent upon this sort of training, that in value far outweighs special products. Said Rousseau, in his *Emilius*, a hundred and twenty years ago: “If, instead of keeping a boy poring over books, I employ him in a workshop, his hands will be busied to the improvement of his understanding; he will become a philosopher while he thinks himself only an artisan.”

As to enduring skill, I will let you judge for yourselves. The blacksmithing has occupied the second-year class about two hundred hours, — ten a week. Each man had his forge and set of tools, and each executed substantially the same set of pieces. Here is a partial set of the work done. The pieces are numbered in the order in which they were done. They were first wrought in cold lead, while the order of the steps and the details of form were studied, and then they were executed in hot iron.

One of our engineering students, who had had about one hundred and twenty hours in the blacksmith’s shop, and an equal time in the machine-shop, writes to thank me especially for insisting upon his shop-practice. Without it he would have had to decline a fine position, which with it he filled satisfactorily.

As our school has seen but two years, I cannot appeal to its

graduates to answer the question: How far is it from our door to positions as journeymen mechanics? Hence, I avail myself of the testimony of Mr. Thomas Foley, instructor of forging, vise-work, and machine-tool work in the Boston Mechanic Art School. He had himself served an apprenticeship of seven years, and after several years at his trade had given instruction for five years. We must consider him a competent judge. In his report to Prof. Runkle, and contributed by the latter to the recent report of the Secretary of the Massachusetts Board of Education, Mr. Foley says: "The system of apprenticeship of the present day, as a general rule, amounts to very little for the apprentice, considering the time he must devote to the learning of his trade. He is kept upon such work as will most profit his employer, who thus protects himself. . . . Now, it appears like throwing away two or three years of one's life to attain a knowledge of any business that can be acquired in the short space of twelve or thirteen days by a proper course of instruction. [I take it that by twelve days he means a hundred and twenty hours distributed over about forty days.] The dexterity which comes from practice can be reached as quickly after the twelve days' instruction as after the two or more years spent as an apprentice under the adverse circumstances mentioned above."

Mr. Foley secures the best results from lessons only three hours long. He adds: "The time is just sufficient to create a vigorous interest without tiring; it also leaves a more lasting impression than by taxing the physical powers for a longer period. We have tried four hours a day, but find that a larger amount of work, and of better quality, can be produced in the three-hour lessons."

I consider this testimony of Mr. Foley very conclusive. It effectually disposes of the claim, so often put forward by practical men, that no boy can learn a trade properly without going to the shop at seven o'clock in the morning and making his day of ten hours, "man-fashion;" and that dirt and drudgery, and hard knocks, and seasons of intense weariness and disgust even, are essential to the education of a good mechanic.

## THE COST.

It remains for me to touch upon the second important question you all have in your minds, namely, that of the cost. You are practical men and women, and you wish now to sit down and count the cost.

We set out in St. Louis to have the best of everything. We bought the best tools, and put in the best furniture. We have plenty of room and light and pure air. We aim to have good teachers and all necessary appliances. Our capacity is about two hundred and forty boys, in three classes of one hundred, eighty, and sixty, in the first year, second year, third year classes respectively.

Our building complete cost about . . . . .	\$33,000
Our tools and school furniture . . . . .	16,000
If we add the cost of the lot (150 x 106½ feet) . . . . .	<u>14,400</u>
We have as the total cost of our plant . . . . .	\$63,400

The building is of brick, three stories high, and very substantial.

Where land is cheap, and less or lighter machinery is used, less money would suffice; but let no one deceive himself by supposing that the reform proposed is to be at once a money-saving one. Such a school costs money, but it is a grand investment. Said one of our benefactors to me not ten days ago, "I feel better satisfied with the money I have put into the Manual Training School than with any other money I have invested in St. Louis."

The same objection, the cost, applies to chemical and physical laboratories of colleges; and one of the main reasons why so many so-called colleges in the Western States devote their attention almost exclusively to classics, mathematics, and history is that they are too poor to properly cultivate chemistry, physics, and practical mechanics.

As to the cost of instruction, the shop is about as expensive per hour as the recitation and drawing rooms. Good mechanics, fairly educated, who are at the same time endowed with the

divine gift of teaching, are rare. We have a first-class machinist and an expert blacksmith, and pay each twelve hundred dollars per year. The size of our divisions is generally limited to twenty members; in drawing, we shall occasionally "double up."

Incidentals — wood, iron, paper, etc., and the wear and tear of tools — amounted last year to about seven dollars per head. The total cost of supplies and instruction in all the departments of the school, and all incidentals, next year is estimated to be seventy-five dollars per pupil.

How then, say you, can this costly reform be accomplished? The public schools have no funds to spare; salaries are still too low, and the demand for extensions outruns the supply. As Col. Jacobson of Chicago has said, "The alternative before you is more and better education at greater expense; or a still greater amount of money wasted on soldiers and policemen, destruction of property, and stoppage of social machinery. The money which the training would cost will be spent in any event. It would have been money in the pocket of Pittsburg if she could have caught her rioters of July, 1877, at an early period of their career, and trained them at any expense just a little beyond the point at which men are likely to burn things promiscuously. It is wiser and better and cheaper to spend our money in training good citizens, than in shooting bad ones."

#### HOW TO GO TO WORK.

There are two ways of going to work: —

*First*, Cut down somewhat, if necessary, the curriculum of higher studies, and incorporate a manual department with your high school. The investment will pay, and the means for further growth will soon be found.

*Second*, Mature your plans, and lay them before your wealthy public-spirited men. Almost for the first time in America, we are harvesting a splendid crop of millionaires. They abound in every city. They know that boundless wealth left to sons and heirs is often a curse, rarely a blessing, and they would fain put it to the noblest uses. In England such wealth would naturally go to the establishment of noble families, or the pur-

chase of grand estates which should be transmitted unimpaired to the oldest sons through successive generations.

Our American peerage shall consist of those who devote the gains of an honorable career to the establishment of institutions for the better education of generations that shall come after them. Let others follow the example of Cornell and Vanderbilt, Stevens of Hoboken, Girard of Philadelphia, Johns Hopkins of Baltimore, Case of Cleveland, Rose of Terre Haute, the Commercial Club of Chicago, and Gottlieb Conzelman, Samuel Cupples, Edwin Harrison, and Ralph Sellew of St. Louis.

## CHAPTER VIII.

THE FRUITS OF MANUAL TRAINING.<sup>1</sup>

THE object of this paper is to consider directly the fruits of manual training. By manual training I do not mean merely the training of the hand and arm. If a school should attempt the very narrow task of teaching only the manual details of a particular trade or trades, it would, as Felix Adler says, violate the rights of the children. It would be doing the very thing I have always protested against. That, or very nearly that, is what is done in the great majority of European trade-schools. They have no place in our American system of education.

The word "manual" must, for the present, be the best word to distinguish that peculiar system of liberal education which recognizes the manual as well as the intellectual. I advocate manual training for all children as an element in general education. I care little what tools are used, so long as proper habits (morals) are formed, and provided the windows of the mind are kept open toward the world of *things* and *forces*, physical as well as spiritual.

We do not wish or propose to neglect or underrate literary and scientific culture; we strive to include all the elements in just proportion. When the manual elements which are essential to a liberal education are universally accepted and incorporated into American schools, the word "manual" may very properly be dropped.

I use the word "liberal" in its strict sense of "free." No education can be "free" which leaves the child no choice, or

---

<sup>1</sup> From an address before the National Teachers' Association at Saratoga, July, 1883.

which gives a bias against any honorable occupation; which walls up the avenues of approach to any vocation requiring intelligence and skill. A truly liberal education educates equally for all spheres of usefulness; it furnishes the broad foundation on which to build the superstructure of a happy, useful, and successful life. To be sure, this claim has been made for the old education, but the claim is not allowed. The new education has the missing features all supplied. The old education was like a two-legged stool, it lacked stability; the new education stands squarely on three legs, and it is steady on the roughest ground.

I claim as the fruits of manual training, when combined, as it always should be, with generous mental and moral training, the following:—

1. Larger classes of boys in the grammar and high schools;
2. Better intellectual development;
3. A more wholesome moral education;
4. Sounder judgments of men and things, and of living issues;
5. Better choice of occupations;
6. A higher degree of material success, individual and social;
7. The elevation of many of the occupations from the realm of brute, unintelligent labor, to positions requiring and rewarding cultivation and skill;
8. The solution of "labor" problems.

I shall touch briefly on each of these points.

1. **BOYS WILL STAY IN SCHOOL LONGER THAN THEY DO NOW.** Every one knows how classes of boys diminish as they approach and pass through the high school. The deserters scale the walls and break for the shelter of active life. The drill is unattractive, and, so far as they can see, of comparatively little value. There is a wide conviction of the inutility of schooling for the great mass of children beyond the primary grades, and this conviction is not limited to any class or grade of intelligence. Wage-workers we must have, and the graduates of the higher grades are not expected to be wage-workers. According to the report of the president of the Chicago School Board, about one and one-eighth per cent of the boys in the public schools are in the high schools. From his figures it appears, that, if every boy in the Chicago public schools should extend his schooling through a high school, the four classes

of the high school would contain some nine thousand boys; in point of fact, they have about four hundred.

Superintendent Hinsdale of Cleveland says, "Of one hundred and eight pupils (boys and girls) entering the primary school, sixty complete the primary, twenty finish the grammar, four are found in the second class of the high, and one graduates from the high school." In St. Louis the average age at which pupils withdraw from the public schools is thirteen and a half years. Now, I doubt if any reflecting person would consider it an unmixed good if every boy in the city should go through the high school as it is at present conducted. Under the circumstances supposed, all would probably admit that some change in the character of the instruction would be necessary.

From the observed influence of manual training upon boys, and indirectly upon the parents, I am led to claim, that, when the last year of the grammar and the high schools includes manual training, they will meet a much wider demand; that the education they afford will be really more valuable; and, consequently, that the attendance of boys will be more than doubled. Add the manual elements, with their freshness and variety, their delightful shop exercises, their healthy intellectual and moral atmosphere, and the living reality of their work, and *the boys will stay in school*. Such a result would be an unmixed good. I have seen boys doing well in a manual training school who could not have been forced to attend an ordinary school. If the city of Boston shall carry out this year, as I hope it will, Superintendent Seaver's plan for a public manual training school for three hundred boys, there will be, in my judgment, one thousand applications for admission during the first three years.

2. BETTER INTELLECTUAL DEVELOPMENT. — I am met here with the objection that I am aiming at an impossibility; that, if I attempt to round out education by the introduction of manual training, to develop the creative or executive side, I shall certainly curtail it of elements more valuable still; that the educational cup is now full; and that, if I pour in my gross material notions on one side, some of the most precious intellectual fluid will certainly flow out on the other.



Now, I deny that the introduction of manual training does of necessity force out any essential feature of mental and moral culture. The cup may be, and probably is, full to overflowing; but it is a shrivelled and one-sided cup. It is as sensitive and active in its own defense as are the walls of the stomach, which, when overfed with ill-assorted food, contracts, rebels, and overflows, but which expands and readily digests generous rations of a varied diet.

The education of the hand is the means of more completely and efficaciously educating the brain. Manual dexterity is but the evidence of a certain kind of mental power; and this mental power, coupled with a familiarity with the tools the hands use, is doubtless the only basis of that sound, practical judgment and ready mastery of material forces which always characterize those well fitted for the duties of active, industrial life.

Intellectual growth is not to be gauged by the length or number of the daily recitations. I firmly believe that in most of our schools there is too much sameness and monotony, too much intellectual weariness and consequent torpor. Hence, if we abridge somewhat the hours given to books, and introduce exercises of a widely different character, the result is a positive intellectual gain. There is plenty of time if you will but use it aright. Throw into the fire those modern instruments of mental torture,—the spelling and defining books. Banish English grammar, and confine to reasonable limits geography and word-analysis. Take mathematics, literature, science, and art in just proportion, and you will have time enough for drawing and the study of tools and mechanical methods.

No one can learn from a book the true force of technical terms and definitions, nor the properties of materials. All descriptive words and names must base their meaning upon our own consciousness of the things they signify. The obscurities of the text-books (often doubly obscure from the lack of proper training on the part of the authors, who describe processes they never tried, and objects they never saw) vanish before the steady gaze of a boy whose hands and eyes have assisted in the building of mental images.

Then, again, the habit of clear-headedness, of precision in

regard to the minor details of a subject (which is absolutely essential in the shop), an exact and experimental knowledge of the full force of the words and symbols used, stretches with its wholesome influence into the study of words and the structure of language. As Felix Adler says, the doing of one thing well is the beginning of doing all things well. I am a thorough disbeliever in the doctrine that it is ever educationally useful to commit to memory words which are not understood. The memory has its abundant uses, and should be carefully cultivated; but when it usurps the place of the understanding, when it beguiles the mind into the habit of accepting the images of words for the images of the things the words stand for, then the memory becomes a positive hinderance to intellectual development.<sup>1</sup>

3. A MORE WHOLESOME MORAL EDUCATION. — The finest fruit of education is character; and the more complete and symmetrical, the more perfectly balanced the education, the choicer the fruit.

To begin with, I have noted the good effect of *occupation*. The program of a manual training school has something to interest and inspire every boy. The daily session is six full hours, but I have never found it too long. The school is not a bore; and holidays, except for the name of the thing, are unpopular. I have been forced to make strict rules to prevent the boys from crowding into the shops and drawing rooms on Saturdays and after school hours. There is little tendency,

---

<sup>1</sup> "Unintelligent memorizing is at best a most questionable educational method. For one, I utterly disbelieve in it. It never did me any thing but harm; and learning by heart the Greek grammar did me harm,—a great deal of harm. While I was doing it, the observing and reflective powers lay dormant; indeed, they were systematically suppressed; their exercise was resented as a sort of impertinence. We boys stood up and repeated long rules, and yet longer lists of exceptions to them; and it was drilled into us that we were not there to reason, but to rattle off something written on the blackboard of our minds. The faculties we had in common with the raven were thus cultivated at the expense of that apprehension and reason which, Shakespere tells us, makes man like the angels and God. And so, looking back from this standpoint of thirty years later, and thinking of the game which has now been lost or won, I silently listen to that talk about 'the severe intellectual training,' in which a parrot-like memorizing did its best to degrade boys to the level of learned dogs." — CHARLES FRANCIS ADAMS, JR., *Phi Beta Kappa Oration*, 1883.

therefore, to stroll about, looking for excitement. The exercises of the day fill the mind with thoughts pleasant and profitable, at home and at night. A boy's natural passion for handling, fixing, and making things is systematically guided into channels instructive and useful, as parents freely relate.

Again, success in one branch or study (shop exercises are marked like those of the recitation room) encourages effort in others, and the methods of the shop affect the whole school. Gradually the students acquire two most valuable habits, which are certain to influence their whole lives for good; namely, precision and method. As Professor Runkle says, "Whatever cultivates care, close observation, exactness, patience, and method must be valuable training and preparation for all studies and all pursuits."

Dr. Adler has pointed out, with great force and elegance, the influence of the exercises of the shop upon the formation of character. This influence, he holds, will be "nothing short of revolutionary, inasmuch as it will help to overthrow many of the impure conceptions that prevail at the present day." The tasks we set are not to be judged by commercial standards; our standard is one hundred per cent. The articles we make are not to be sold; they have no pecuniary value; they are merely typical forms; their worth consists in being true or in being beautiful, as the case may be.

The manual training school, when well conducted, seems to me to furnish to its pupils just the opportunity which Walter Scott, in *Waverley*, says that his young hero was losing for ever, — "the opportunity of acquiring habits of firm and assiduous application; of gaining the art of controlling, directing, and concentrating the powers of his mind for earnest investigation, — an art far more essential than even that intimate acquaintance with classical learning which is the primary object of study" (at school).

4. SOUNDER JUDGMENTS OF MEN AND THINGS. — The proverbially poor judgments of scholars have led to the popular belief that theory is one thing and practice a very different thing; that theoretically a thing is one way, practically another. The truth is, that correct theory and practice agree perfectly.

If in his theory one leaves out a single element of the problem, or fails to give each its due weight, his theory is false. The school-men have been so accustomed to living in an ideal world, the world of books and books only, where they have found only ideal problems, and they have been so ignorant of the real world and the conditions of real problems, that their solutions have very generally been false.

A harmonious culture develops common-sense, and common-sense is at the basis of good judgment. We aim to raise that kind of fruit. Boys who put every theory to the practical test; who know something about what the idealists call "the total depravity of inanimate things;" who probe and test every statement and appliance; with whom authority and tradition, the bane of too much "book-learning," have little influence, and who therefore are apt to take things at their true value, — are fitted to focus correctly upon the problems of real life.

We hear much, and with good reason, of the value of directive intelligence. To be a director, one must have good judgment. He who would successfully direct the labor of other men must first learn the art of successful labor himself; and he who would direct a machine properly must understand the principles of its construction, and be personally skilled in the arts of preservation and repair. Dr. Harris, therefore, tells but a half-truth when he says that "the new discovery (the invention of a new tool) will make the trade learned to-day, after a long and tedious apprenticeship, useless to-morrow. The practical education, therefore, is not an education of the hand to skill, but of the brain to directive intelligence. The educated man can learn to direct a new machine in three weeks, while it requires three years to learn a new manual labor." (*Education*, May-June, 1883.)

This last sentence is not clear to me. Somehow it seems to imply that the man who learns to run a machine should be more intelligent, and require more education, than the man who made it. As to "directive intelligence," I respectfully submit the following as a substitute for the dictum of Mr. Harris: "The practical education is, therefore, an education of the

hand to skill and of the brain to intelligence. The combination will give the highest directive power."

5. BETTER CHOICE OF OCCUPATIONS. — This point is one of the greatest importance, for out of it are the issues of life. An error here is often fatal. But to choose without knowledge is to draw as in a lottery; and when boys know neither themselves nor the world they are to live in, and when parents do not know their own children, it is more than an even chance that the square plug will get into the round hole.

Parents often complain to me that their sons who have been to school all their lives have no choice of occupation, or that they choose to be accountants or clerks, instead of manufacturers or mechanics. These complaints are invariably unreasonable; for how can one choose at all, or wisely, when he knows so little! Yet their decisions are natural.

I confidently believe that the development of the manual elements in school will prevent those serious errors in the choice of a vocation which too often wreck the fondest hopes. It is not assumed that every boy who enters a manual training school is to be a mechanic; his training leaves him *free*. No pupils were ever more unprejudiced, better prepared to look below the surface, less the victims of a false gentility. Some find that they have no taste for manual arts, and will turn into other paths, — law, medicine, or literature. Great facility in the acquisition and use of language is often accompanied by a lack of either mechanical interest or power. When such a bias is discovered, the lad should unquestionably be sent to his grammar and dictionary rather than to the laboratory or draughting-room. On the other hand, decided aptitude for handicraft is not unfrequently coupled with a strong aversion to, and unfitness for, abstract and theoretical investigations, and especially for committing to memory.

There can be no doubt that, in such cases, more time should be spent in the shop, and less in the lecture and recitation room. Some who develop both natural skill and strong intellectual powers will push on through the polytechnic school into professional life, as engineers and scientists. Others will find their greatest usefulness, as well as highest happiness,

in some branch of mechanical work, into which they will readily step when they leave school. All will gain intellectually by their experience in contact with things. The grand result will be an increasing interest in manufacturing pursuits, more intelligent mechanics, more successful manufacturers, better lawyers, more skillful physicians, and more useful citizens.

In the past comparatively few of the better educated have sought the manual occupations. The one-sided training of the schools has divided active men into two classes, — those who have sought to live by the work of their own hands, and those who have sought to live by the work of other men's hands.

Hitherto men who have aimed to cultivate their brains have neglected their hands; and those who have labored with their hands have found no opportunity to specially cultivate their brains. The crying demand to-day is for intellectual combined with manual training. It is this want that the manual training school aims to supply.

6. MATERIAL SUCCESS FOR THE INDIVIDUAL AND FOR THE COMMUNITY. — Material success ought not to be the chief object in life, tho it may be sought with honor, and worthily won; in fact, success would appear to be inevitable to one who possesses health and good judgment, and who, having chosen his occupation wisely, follows it faithfully. This point might, then, be granted as a corollary to those already given and without further argument.

Our graduates have been out of school less than a year, but I have seen enough to justify me in saying that their chances of material success are unusually good. As workmen, they will soon step to the front. As employers and manufacturers, they will be self-directing and efficient inspectors; they will be little exposed to the wiles of incompetent workmen.

On the other hand, communities will prosper when their young men prosper. This is the *dynamic age*; the great forces of Nature are being harnessed to do our work, and we are just beginning to learn how to drive. Invention is in its youth, and manual training is the very breath of its nostrils.

Some appear to think that the continued invention of tools

and new machines will diminish the demand for men skilled in mechanical matters; but they are clearly wrong. True, they will diminish the demand for *unintelligent* labor, — and some prominent educators, who take ground against manual training, have apparently no idea of labor except unintelligent labor. If there are more machines, there must be more makers, inventors, and directors. Not one useful invention in ten is made by a man who is not a skilled mechanic. But, as I have said, the mechanics have suffered from a one-sided education. They have paid too little attention to science and the graphic arts. Hence every manual pursuit will become elevated in the intellectual scale when mechanics are broadly, liberally trained.

7. THE ELEVATION OF MANUAL OCCUPATIONS FROM THE REALM OF BRUTE, UNINTELLIGENT LABOR TO A POSITION REQUIRING AND REWARDING CULTIVATION AND SKILL. — A brute can exert brute strength: to man alone is it given to invent and use tools. Man subdues Nature and develops art through the instrumentality of tools. To turn a crank, or to carry a hod, one needs only muscular power. But to devise and build the light engine, which, under the direction of a single intelligent master-spirit, shall lift the burden of a hundred men, requires a high degree of intelligence and manual skill. So the hewers of wood and the drawers of water are in this age of invention replaced by saw and planing mills and water-works requiring some of the most elaborate embodiments of thought and skill. Can any one stand beside the modern drawers of water, the mighty engines that day and night draw from the Father of Waters the abundant supply of a hundred thousand St. Louis homes, and not bow before the evidence of “cultured minds and skillful hands,” written in unmistakable characters all over the vast machinery?

In like manner every occupation becomes ennobled by the transforming influence of thought and skill. The farmer of old yoked his wife with his cow, and together they dragged the clumsy plow or transported the scanty harvest. Down to fifty years ago the life of a farmer was associated with unceasing, stupefying toil. What will it be when every farmer's boy is properly educated and trained? Farming is rapidly becoming

a matter of horse-power, steam-power, and machinery. Who, then, shall follow the farm with honor, pleasure, and success? Evidently only he whose cultivated mind and trained hands make him a master of the tools he must use. With his bench and sharp-edged tools, with his forge and his lathe, and with his chemical laboratory, he will direct and sustain his farm with unparalleled efficiency.

Here is where the influence of manual training will be most beneficial. It will bring into the manual occupations a new element, a fairly educated class, which will greatly increase their value, at the same time that it gives them new dignity.

8. THE SOLUTION OF LABOR PROBLEMS. — Finally, I claim that the manual training school furnishes the solution of the problem of labor *vs.* capital. The new education will give more complete development, versatility, and adaptability to circumstance. No liberally trained workman can be a slave to a method, or depend upon the demand for a particular article or kind of labor. It is only the uneducated, unintelligent mechanic who suffers from the invention of a new tool. The thoroughly trained mechanic enjoys the extraordinary advantage of being able, like the well-taught mathematician, to apply his skill to every problem; with every new tool and new process he rises to new usefulness and worth.

The leaders of mobs are not illiterate, but they are narrow, the victims of a one-sided education; and their followers are the victims of a double one-sidedness. Give them a liberal training, and you emancipate them alike from the tyranny of unworthy leaders and the slavery of a vocation. The sense of hardship and wrong will never come, and bloody riots will cease, when workingmen shall have such intellectual, mechanical, and moral culture, that new tools, new processes, and new machines will only furnish opportunities for more culture, and add new dignity and respect to their calling.

NOTE. — In May, 1886, I gave the following brief statement of the fruits of manual training, in the *Journal of Education*: —

The value of manual training, when properly combined with literary, scientific, and mathematical studies, will be shown in various ways.



1. Science and mathematics will profit from a better understanding of forms, materials, and processes, and from the readiness with which their principles may be illustrated.

2. Without shop-work, drawing loses half its value.

3. Correct notions of things, relations, and forces, derived from actual handling and doing, go far toward a just comprehension of language in general; that is, manual training cultivates the mechanical and scientific imagination, and enables one to see the force of metaphors in which physical terms are employed to express metaphysical truths.

4. Manual training will stimulate a love for simplicity of statement, and a disposition to reject fine-sounding words whose meaning is obscure.

5. It will awaken a lively interest in school, and invest dull subjects with new life.

6. It will keep boys and girls out of mischief, both in and out of school.

7. It will keep boys longer at school.

8. It will give boys with strong mechanical aptitudes, and fondness for objective study, an equal chance with those of good memories for language.

9. It will materially aid in the selection of occupations when school-life is over.

10. It will enable an employer of labor to better estimate the comparative value of unskilled and skilled labor, and to exercise a higher consideration for the laboring man.

11. It will raise the standards of attainments in mechanical occupations, and invest them with new dignity and worth.

12. It will increase the bread-winning and home-making power of the average boy, who has his bread to win and his home to make.

13. It will stimulate invention. The age of invention is yet to come, and manual training is the very breath of its nostrils.

14. We shall enjoy the extraordinary advantage of having lawyers, journalists, and politicians with more correct views of social and national conditions and problems.

To the above I will now add:—

15. It will help to prevent the growth of a feeling of contempt for manual occupations and for those who live by manual labor.

16. It will to a certain extent readjust social standards in the interest of true manliness and intrinsic worth.

17. It will accelerate the progress of civilization by greatly diminishing the criminal and pauper classes, which are largely made up of those who are neither willing nor able to earn an honest living.

18. It will show itself in a hundred ways in the future homes of our present pupils: on the one hand, in the convenience and economy of useful appliances; on the other, in evidences of good taste in matters of grace and beauty.

## CHAPTER IX.

MANUAL TRAINING A FEATURE IN GENERAL  
EDUCATION.<sup>1</sup>

WITH wonderful unanimity the educational forces of America are facing in the new direction. Formal education is much broader than of old, and the methods and materials used are so new or so changed, that we call the result the

## NEW EDUCATION.

It is scarcely necessary to add that the "new" education includes the "old." We tear down no essential parts of the old temple, but we have added at least two wings which were needed to make a symmetrical whole. The natural science wing brings in a whole world of new material, and a totally new method of developing ideas. The other wing is that of manual training, including a variety of drawing and the intelligent use of a large range of typical tools and materials.

"Man," says Carlyle, "is a tool-using animal. He can use tools, can devise tools; with these the granite mountains melt into light dust before him; he kneads glowing iron as if it were soft paste; seas are his smooth highway, winds and fire his unwearied steeds. Nowhere do you find him without tools: without tools, he is nothing; with tools, he is all."

You know how bird-trainers teach a canary to sing a particular tune. The poor bird is put in a dark place, where he can see nothing of interest, and then compelled to hear the tune and nothing else. Even a bird is constrained to a certain amount of intellectual activity, and in sheer desperation he

---

<sup>1</sup> An address delivered before the Social Science Association of Philadelphia, in December, 1885.

sings the only thing he is allowed to think of. Have we not been training our boys too much on the same plan? In our anxiety to keep out every thing low and sordid, we have kept out the influence of the working world as much as possible. We have striven to make artists rather than artisans, officers rather than privates, essayists rather than craftsmen. Instead of teaching how to get a good living as the *sine qua non* of useful, independent citizenship, we have assumed the good living and have taught how to improve its advantages. We have walled in the vision of our pupils till they could look only in certain directions, see certain activities, study certain forms of mental life. Half the occupations of men, half the domains of knowledge, many of the means and ends of intellectual culture, much that is specially favorable to moral and spiritual growth, are beyond their horizon. Need any one be surprised at the result of such seclusion? Like the bird, they learn certain tongues, they master certain arts, they become familiar with a certain limited round of intellectual life. There is little freedom of choice or chance for liberal growth. They must, perforce, travel certain paths. And later on they think, and for the most part with good reason, that to use their education — by which they mean their book knowledge — they must go into the counting-room, become salesmen, or go into the “learned professions.” In avoiding, with almost perfect unanimity, the mechanic arts, they do not make an intelligent choice; they follow only an ignorant prejudice. Now, this evil of narrowness, this “violation” of the “rights” of children, as Prof. Felix Adler calls it, is what we are trying to cure by the introduction of the manual elements.

#### EXCELLENCE OF OUR COMMON SCHOOLS.

Let me be just to the bridge that has brought us over, to the ladder we have ourselves climbed. The schools need no defender, — they speak for themselves. To the public schools of Massachusetts, I owe more than I can ever pay. From the door of a country high school I stepped up to the college gate, as thousands of boys have done since. Far be it from me to say an unkind or disloyal word of the common-school system.

The schools of America are the brightest jewel in her crown, the sure anchor of her hope.

But does not the world move? Does it not become the schoolmaster to keep step to the notes of progress? Shall the demands of the age greatly change? shall we depart widely from the ways of our fathers in every thing else, in our industries, our amusements, in the circumstances and surroundings of our homes, and yet make no change in the content of our school education? That the education afforded has in the main been judicious and fairly complete, I do not call in question.

While I think it altogether probable that throughout all grades there is too much of committing to memory the words, statements, and conclusions of others, as mere facts to be remembered for their own sake, and too little practice in getting at knowledge for one's self and drawing one's own conclusions, under the guidance, but not at the command, of the teacher, I shall confine my remarks to-night to what we are doing, or ought to do, for boys from the age of thirteen to seventeen or eighteen. Much that is serviceable for boys is equally so for the girls; much has yet to be done in developing the details for young children. I insist that some manual training should run through the entire course. The necessary appliances for the primary and grammar grades are simple and few; the most essential thing being teachers, into whose preparatory training manual elements have entered in their due proportion. By the eighth or ninth year of school life, the pupils are ready for the systematic and comprehensive work I will now give in outline.

#### THE DAILY PROGRAM OF THE MANUAL TRAINING SCHOOL.

The school-time of the pupils is about equally divided between mental and manual exercises. The daily session begins at 9 A.M., and closes at 3.30 P.M., thirty minutes being allowed for lunch. Each pupil has daily three recitations, one hour of drawing and penmanship, and two hours of shop-practice.

## THE COURSE OF INSTRUCTION

covers three years, and embraces five parallel lines,—three purely intellectual, and two both intellectual and manual,—as follows:—

*First*, A course of pure mathematics, including arithmetic, algebra, geometry, and plane trigonometry.

*Second*, A course in science and applied mathematics, including physical geography, botany, natural philosophy, chemistry, mechanics, mensuration, and book-keeping.

*Third*, A course in language and literature, including English grammar, spelling, composition, literature, history, and the elements of political science and economy. Latin and French are introduced as electives with English or science.

*Fourth*, A course in penmanship, free-hand and mechanical drawing.

*Fifth*, A course of tool instruction, including carpentry, wood-turning, molding, brazing, soldering, forging, and bench and machine work in metals.

Students have no option or election as to particular studies, except as regards Latin and French; each must conform to the course as laid down, and take every branch in its order.

## A BROADER EDUCATION.

You will see, then, that we have no mean or narrow object. "The education which the manual training school represents is a broader, and not, as the opponents of the new education assert, a narrower education." We put the whole boy to school, not a part of him, and we train him by the most invigorating and logical methods. We believe that mental activity and growth are closely allied to physical activity and growth, and that each is secured more readily and more fully in connection with the other than by itself.

There can be no question as to the value of language and letters, of books and literary methods, in general education. No science can exist without letters. We only insist that neither as an end nor as a means does literature, even with the

aid of pure mathematics, supply more than half the needs of a healthy education.<sup>1</sup>

#### LITERARY AND SCIENCE CULTURE.

Pure literature is a matter of books alone. It deals with words and symbols, and is concerned only with the forms of verbal expression. The thought expressed may belong to any department of science or philosophy; to psychology, botany, or metaphysics; to religion, history, technology, or art: the form belongs to literature, and it may be in the language of any people. The matter of form is in the realm of authority, and every thing is settled by an appeal to authorities.<sup>2</sup> The conventions of society are such that too often education is gauged by the amount of literary culture involved. We are the slaves

---

<sup>1</sup> "A literary training is not the best preparation for the pursuits in which a large proportion of the population are now engaged. . . . This [literary] training is the survival of a method well enough adapted at one time to those who alone received education [i.e. the English gentry and the nobility], but unintentionally extended to other classes, who, on account of the difference of their pursuits, require a totally different system of education."—SIR PHILIP MAGNUS, *Report of the Education Conference*, London, 1884, vol. ii. p. 5.

Sir Philip was a member of the Royal Commission on Technical Instruction, and its report was largely written by him. It is interesting to note that, after a very thorough examination of the question of the best preliminary education for higher technical instruction at home and abroad, and especially in Germany, where a body of university professors had recently pronounced against the real schools and in favor of the gymnasias, he comes to the conclusion that a curriculum consisting of mathematics and practical science (including workshop instruction), drawing, English language and literature, French, German, geography, and history is the best preparation for the higher technical instruction.

"But," he adds,—"and here he touches on one of the reasons for the comparative unpopularity of the 'modern side' schools, viz., incompetent teachers,— "in order that it may yield the same mental discipline and intellectual advantages which a boy may get at one of our first-grade public [endowed] schools [like Rugby, Eton, Charterhouse, etc.], under the alternative classical training, the masters who are to teach science must be men of the same cultivated order as those under whose direction our public schools are now placed."—*Ibid.*

"So long as primary education is literary instead of real, and so long as there is a gulf fixed between primary and secondary education, technical instruction will continue to be a sort of parasitic off-shoot, like the misletoe."—*Editor of London Journal of Education*, June 1, 1887.

<sup>2</sup> I am well aware that there are many who define literature differently. Taine says that a book belongs to literature in so far as it expresses beauty, sweetness, purity, or emotions of any sort; in so far as it illustrates the action of forces, it belongs to science. John Burroughs says that the province of literature is sentiment and imagination, while science deals with demonstrable facts. John

of fashion in education as well as in dress, and often fear to claim for other kinds of culture, as useful, as humane, as invigorating, as broadly healthful, as that of letters, the value and dignity they really possess. In defence of the new education, it has been said that "the intellectual culture of active art is far more vigorous than that of literature. In literary culture, we feebly and indefinitely grasp ideas by their association with printed words. There is no life, no force in the object of our study. In industrial art, we are continually stimulated by the presence of the object, and the operations we are performing; and our perceptions are clear, positive, and exact. The concentrated attention, the close observation, the ingenuity, invention, and judgment in use in art are far superior as mental discipline to any that literature can give."<sup>1</sup>

The study of science in the new education involves both new materials and new methods. The unfruitfulness of all attempts to teach a child science, in which at first there should be no such thing as authority, from a book; as would be the

---

Morley claims that not only the form, but the substance of history, politics, psychology, ethics, art, and religion belong to literature.

When we consider the number and importance of the demonstrable facts there are in politics, psychology, ethics, art, and religion, we shall realize how far these enthusiastic literateurs differ in defining their domains.

<sup>1</sup> Prof. Bain says, "The impression made on the mind by the actual objects, as seen, handled, and operated upon, is far beyond the efficacy of words or description." Sir Philip Magnus thus speaks of the pupils of Finsbury College who entered on an examination chiefly literary: "Great difficulty has been experienced in getting students to properly observe and interpret the results of their experiments; and it has been only too apparent that their previous education has done little to develop their reasoning powers."

In a lecture delivered before the Royal Institution of Great Britain, Canon Farrar, the distinguished author and philologist, a master of Harrow, and for thirteen years a classical teacher, thus avows "his deliberate opinion, arrived at in the teeth of the strongest possible bias and prejudice in the opposite direction, — arrived at with the fullest possible knowledge of every single argument which may be urged on the other side," — "I must avow my distinct conviction that our present system of exclusively classical education, as a whole, and carried on as we do carry it on, is a deplorable failure. I say it knowing that the words are strong words, but not without having considered them well; I say it because that system has been 'weighed in the balance and found wanting.' It is no epigram, but a simple fact, to say that classical education neglects all the powers of some minds, and some of the powers of all minds." He regrets especially the "deadening" effect on the sensibilities of burdening the memory with unmeaning and useless words.

case for a language where authority is every thing, has produced a revolution in science teaching. But the science laboratory is a workshop as well, and success there depends in part upon manual skill in the use of tools, in mechanical processes, and in the graphic arts. Moreover, we believe that healthy growth is always pleasurable, whether of mind or body. We believe that it is no more necessary to give the mind disagreeable, wearisome, unintelligible exercises, than it is to give the body disgusting, ill-assorted, indigestible food. Did you ever see children so weary of books that study was impossible? Did you ever see one whose mind was nauseated with spelling-books, lexicons, and grammars, and an endless hash of words and definitions? And did you, in such a case, call in the two doctors, Johann Pestalozzi and Friedrich Froebel? And did you watch the magic influence of a diet of things prescribed by the former in the place of words, and a little vigorous practice in doing, in the place of talking, under the direction of the latter?

When the limit of sharp attention and lively interest is reached, you have reached the limit of profitable study. If you can hold the attention of a class but ten minutes, it is worse than a waste of time to make the exercise fifteen. The weary intellects will roll themselves up in self-defence, and suffer as patiently as they can; but the memory of those moments of torture lingers and throws its dreadful shadow over the exercise as it comes up again on the morrow. And how automatically, as these over-taught children take their places again, do they roll themselves up into an attitude of mental stupidity! Intellectual growth is not to be gauged by the length or number of the daily recitations. I firmly believe that in most of our schools there is too much sameness and monotony, too much intellectual weariness and consequent torpor.

A moment's reflection will convince you that the ordinary secondary school, whether high school or academy, does not meet the general want of thirteen- and fifteen-year-old boys. The curriculum of studies is laid out for that very limited class of pupils who are destined, or self-selected without intelligent choice, for literary or professional life. With all that work I



have no wish to interfere. I would even raise all professional and literary standards. I would incorporate with their study of classics and mathematics and authoritative science such a manual training as would make them better literary and professional men.

#### MUCH MORE THAN MEMORY.

But I would do much more. I would make school attractive and indispensable to a large class of boys, whose controlling interests are not in the study of words, the forms of speech, or the boundless mass of information which is given in books; and I would give such boys a fair chance of adequate development. Such boys are not necessarily blockheads, nor even dull. Their intellectual powers may be strong, though their strength lies not in the direction of memory. The claims of this class of boys have been set forth by no one so eloquently as by Gen. Francis A. Walker. Says he, and I give almost his exact words: "There is now no place, or only a most uncomfortable one, for those boys who are strong in perception, apt in manipulation, and correct in the interpretation of phenomena, but who are not good at memorizing, or rehearsing the opinions and statements of others; or who, by their diffidence or slowness of speech, are unfitted for ordinary intellectual gymnastics. These boys are quite as numerous as the other sort, and are quite as deserving of sympathy and respect, beside being rather better qualified to become of use in the industrial and social order. And yet for this class of boys the school offers almost nothing upon which they can employ their priceless powers. They may, by laboring very painfully over the prescribed but uncongenial exercises, escape the stigma of being blockheads; but they can never do very well in them. They will always appear to disadvantage when compared with the boys with good memories for words, whose mental and moral natures accept with pleasure or without serious question the statements and conclusions of others. Such boys are practically plowed under in our schools, as not worth harvesting. And yet it not infrequently happens that the boy who is regarded as dull because he cannot master an artificial system of grammatical analysis,

isn't worth a cent for giving a list of the kings of England, who doesn't know and doesn't care what are the principal productions of Borneo, — has a better pair of eyes, a better pair of hands, a better judgment, and, even by the standards of the merchant, the manufacturer, and the railroad president, a better head, than his master."

Now the manual training school proposes to cultivate and

#### HARVEST BOTH KINDS OF BOYS.

As Col. Jacobson says, "Manual training means not fewer, but more, ladies and gentlemen to the acre."

There comes a time in the life of every boy when he craves with an irresistible appetite what may be called food for his physical nature; when the senses are most acute; when he is exquisitely conscious of his growing strength, his increasing power over the external world; when his budding manhood opens the door into the great workshop of Nature, and he is satisfied with nothing less than actual contact with concrete forms and tangible forces.

At this period the records of the past have little interest for a healthy boy. He must feel and act for himself; he must turn the key with his own hands, and himself unbar the gates. He has no natural appetite to destroy; he destroys because he can not create. He can destroy without being taught how; but how to build, how to construct, how to execute, — these require instruction, training, system, and they yield the keener pleasure.

The boy demands reasons; and arbitrary, unmeaning rules are extremely distasteful. Until he has a basis of personal physical experience with which he may digest the experience of others, books have little meaning and are of little value.

Then is the time to give him manual training. Give him his saw, plane, and chisel. Give him his lathe, his forge, and anvil. Give him his blow-pipe and crucible, his magnet and his engine, and teach him their logic and their power. His mind will absorb them all with infinite relish. In their forms and uses he will read the thoughts of men for many generations.

Do not be anxious lest he have no opportunity to develop

literary taste. There is not a single influence flowing from manual training which is hostile to good books. Our graduates are hungry for good books, and they profit by them.

Hence, if we abridge, in some cases, the hours given to books and the time wasted in idleness, and introduce exercises of a widely different character, the result is a positive intellectual gain. There is plenty of time if you will but use it aright. The students of a well-conducted manual training school are intellectually as active and vigorous as in any high school. Nay, more, I claim — and I have had good opportunity to observe the facts — that even on the intellectual side the manual training boy has a decided advantage. I have been in charge of both kinds of schools, and I know whereof I speak. The education of the hand is the means of more completely and efficaciously educating the brain.

#### INTELLECTUAL VALUE.

Manual exercises, which are at the same time intellectual exercises, are highly attractive to healthy boys. If you doubt this, go into the shops of a manual training school and see for yourselves. Go, for instance, into our forging-shop, where metals are wrought through the agency of heat. A score of young Vulcans, bare-armed, leather-aproned, with many a drop of honest sweat, stand up to their anvils with an unconscious earnestness which shows how much they enjoy their work. What are they doing? They are using brains and hands. They are studying definitions in the only dictionary which really defines. Where else can they learn the meaning of such words as “iron,” “steel,” “welding,” “tempering,” “upsetting,” “chilling,” etc.? And in the shop where metals are wrought cold (which, for want of a better name, we call our machine-shop), every new exercise is like a delightful trip into a new field of thought and investigation. Every exercise, if properly conducted, is both mental and manual. Every tool used, and every process followed, has its history, its genesis, its evolution. Says Supt. Seaver of Boston: “Manual training is essential to the right and full development of the human mind, and therefore no less beneficial to those who are not

going to become artisans than to those who are. The workshop method of instruction is of great educational value, for it brings the learner face to face with the facts of nature; his mind increases in knowledge by direct personal experience with forms of matter, and manifestations of force. No mere words intervene. The manual exercises of the shop train mental power, rather than load the memory; they fill the mind with the solid merchandise of knowledge, and not with its empty packing-cases."

Supt. Dowd, of the Toledo public schools, says: "It is certainly true that the training of the manual training school lets in a flood of light upon a thousand things but imperfectly understood before."

Manual dexterity is but the evidence of a certain kind of mental power. Certain intellectual faculties, such as observation and judgment in inductive reasoning, can not be properly trained except through the instrumentality of the hand. The proverbial caution of the practical manipulator, and his distrust of mere theory, — which means reasoning based on assumed, not real, facts, — show how unsafe is reasoning not founded on the closest observation and intimate knowledge of the facts of nature.

A manual training school does not stop with the training of the hand. Physical dexterity is but one, and the very least, of the many things sought; and this is sought more as a means than as an end. The great end is education, — the development of the mind and body, the simultaneous culture of the intellectual, physical, and moral faculties. We believe in the study of

#### THINGS FIRST, THEIR SYMBOLS SECOND.

I am almost ready to say, "Confusion to the memory of Sam Johnson!" for, since he started the fashion of making dictionaries, pupils have been set to learn about substances, products, and processes from dictionaries rather than from things themselves.

The first step of the new education was the introduction of explanatory pictures and diagrams in the books studied and read. This was a great gain, and many of our illustrated text-

books are to-day marvels of excellence. As books, they leave little to be desired. But, neither alone nor with pictures, can words supply the want of things themselves. Next came the introduction of apparatus and models which the teacher could handle and show to his pupils, and sometimes, if he knew how, could use before them. The lecture method was another important gain, and it has accomplished much good. The difficulties attending it, however, have been such as to prevent its general adoption, and its use has been limited to schools of high grade.

The next step, and the one we are now taking, is the adoption of

#### THE LABORATORY,

the putting of things, materials, apparatus, tools, and machines into the hands of the pupils themselves, and giving them a conscious knowledge of properties, relations, and processes.<sup>1</sup> This is the crowning feature in education. It is manifest on the one side in the kindergarten; on the other, in the physical, chemical, and dynamic laboratories; while between the two come the shops and laboratories and drawing rooms of the manual training school. In this last-named school we strive to get the benefit of all the progress made. We aim to have the best text-books, the best illustrations, the best apparatus, the best shop and tools, and the best teachers.<sup>2</sup>

---

<sup>1</sup> As Mr. Fiske says in his *Destiny of Man* (chap. vii.): "In a very deep sense all human science is but the increment of the power of the eye, and all human art is the increment of the power of the hand. Vision and manipulation — these, in their countless and transfigured forms, are the two co-operating factors in all intellectual progress."

<sup>2</sup> "The old method [of education] occupied itself mainly with the study of language; the new method passed beyond language to the study of the actual phenomena of nature. The old method has for its end lingual accomplishments; the new method, a real knowledge of the characters and relations of natural things. The old method trains the verbal memory, and the reason, so far as it is exercised in transposing thought from one form of expression to another; the new method cultivates the powers of observation and the faculty of reasoning upon the objects of experience, so as to educate the judgment in dealing with the problems of life. The old method left uncultivated whole tracts of the mind that are of supreme importance in gaining a knowledge of the actual properties and principles of things which are fundamental in our progressive civilization; the new method begins with the systematic cultivation of these neglected mental powers." — DR. E. L. YOUMANS in *Popular Science Monthly*, 1883.

Milton recognized but five professions open to educated youth; viz., those of the theologian, the lawyer, the statesman, the soldier, and the gentleman, — the last being defined by him as one “who retires himself to the enjoyments of ease and luxury.” On the other hand, J. Scott Russell, one of the first of England’s educated and practical men, enumerates in his plan of an English technical university, after excluding theology, law, and medicine, twenty-two modern professions, for which, in some way, education is to be provided.

#### MODERN PROFESSIONS.

It was formerly supposed that the manufacturer, the miner, the builder of houses or bridges or ships, the millwright, the farmer, the man of commerce, etc., needed no education beyond that gained by actual work at his trade or desk. Now, however, such strides have been taken in all these callings, through the application of the principles of modern science, that none but carefully trained and educated men can expect to secure and keep places of honor and profit in them.

Now, without neglecting to train our lawyers, engineers, and physicians, literary men and gentlemen of leisure, should we not at least as directly aim to train these other men for their work?

We want an education that shall develop the whole man. All his intellectual, moral, and physical powers should be drawn out, and trained and fitted for doing good service in the battle of life. We want

#### WISE HEADS AND SKILLFUL HANDS.

There has been a growing demand, not only for men of knowledge, but for men of skill, in every department of human activity. Have our schools and colleges and universities been equal to the demand? Are we satisfied with what they have produced?

There is a wide conviction of the inutility of schooling for the great mass of children beyond the primary grades, and this conviction is not limited to any class or grade of intelligence. According to the report of the president of the Chicago school

board, about one and one-eighth per cent of the boys in the public schools are in the high schools. From his figures it appears, that, if every boy in the Chicago public schools should extend his schooling through a high school, the four classes of the high schools would contain some nine thousand boys; in point of fact, they have about four hundred. Has the school-board of Chicago done its full duty to the eighty-six hundred boys who are old enough to be in the high schools, and yet are not there?

If a manual training school could draw in four hundred more of them, would it not be worth the doing? I think it would a hundred times over.

From the observed influence of manual training upon boys, and indirectly upon the parents, I am led to claim, that, when the last year of the grammar and the high schools includes manual training, they will meet a wider demand; that the education they afford will be really more valuable, and consequently that the attendance of boys will be more than doubled. Add the manual elements with their freshness and variety, their delightful shop exercise, their healthy intellectual and moral atmosphere, and the living reality of their work, and the boys will stay in school. Such a result would be an unmixed good. I have seen boys doing well in a manual training school, who could not have been forced to attend an ordinary school.

I well know how firmly fixed is the present curriculum of study in the secondary schools, by how many traditions it is supported, and how unfamiliar and strange the manual elements appear to our present corps of teachers.

But let me assure them that the manual exercises are in no way demoralizing. Every shop and drawing room, like every other laboratory, is a part of the school. Boys go from mathematics to shop, and from shop to Latin or English, as naturally as from mathematics direct to Latin. Shop-work is not play, though nineteen out of twenty boys enjoy it as heartily. All the work is logically arranged, and simultaneous class exercises are rigidly insisted on. The difficulties of keeping a class together are no greater than they are in physics and chemistry.

Some of the things said about us are marked by a great lack

of appreciation of our methods and results. For instance, an Illinois professor said, a few years ago, that hammering wood was such a different matter from hammering iron, that not only was skill in one branch of no value in the other, but that it was a positive hinderance. At once the argument was caught up by the opponents of manual training, and we were entertained by learned discussions of the various arts of hammering by those who really knew nothing about them. It is as though one should insist that a knowledge of French is a hinderance to the learning of Spanish, or a knowledge of Latin an obstacle to the mastery of Greek. It is asserted that there can be no such thing as a general training in the use of tools, and they point to the cramped muscles and unintelligent automatonism of a man, who for years has headed pins or stamped small pieces of tin, as exhibiting the baneful effects of manual training! Is it possible that such people know what we mean by manual training?

#### THE HABIT OF THINKING.

Can they be aware that, in no American manual training school (and there are no such schools in France or Germany or Russia), is the number of hours devoted to the entire series of wood-working tools over four hundred? that the stage of mechanical habit is never reached? that the only habit actually acquired is that of thinking? that no blow is struck, no line drawn, no motion regulated, from muscular habit? that the quality of every act springs from the conscious will accompanied by a definite act of judgment? Can such a limited training produce a high degree of manual skill? Of course not. We have distinctly stated that our pupils do not become skilled mechanics, nor do we teach them the full details of a single trade. The tools whose theory, care, and use we teach are representative; and the processes, which we teach just far enough to make every step clear and experimentally understood, equally underlie a score of trades. I say experimentally understood; by which I mean that it is not enough to know that a certain outline is to be produced, or a certain adaptation is to be secured, but one must know just the force to be



directed, just the motions needed, and in their order, and all as the result of the closest attention and steady intellectual activity.

What, then, is this so-called manual training but continuous mental discipline? I have already spoken of the mental effect of science study. I claim equally beneficial effects for the thoughtful study of the theory and use of the tools which are the product of ages of human experience.

#### OBJECT OF MANUAL TRAINING.

The object of the introduction of manual training is not to make mechanics. I have said that many times, and I find continual need of repeating the statement. We teach banking, not because we expect our pupils to become bankers; and we teach drawing, not because we expect to train architects or artists or engineers; and we teach the use of tools, the properties of materials, and the methods of the arts, not because we expect our boys to become artisans. We teach them the United States Constitution and some of the Acts of Congress, not because we expect them all to become congressmen. But we do expect that our boys will at least have something to do with bankers, and architects, and artists, and engineers, and artisans; and we expect all to become good citizens. Our great object is educational: other objects are secondary. That industrial results will surely follow, I have not the least doubt; but they will take care of themselves. Just as a love for the beautiful follows a love for the true, and as the high arts can not thrive except on the firm foundation of the low ones, so a higher and finer development of all industrial standards is sure to follow a rational study of the underlying principles and methods. Every object of attention put into the schoolroom should be put there for two reasons,—one educational, the other economic. Training, culture, skill, come first; knowledge about persons, things, places, customs, tools, methods, comes second. It is only by securing both objects that the pupil gains the great prize, which is power to deal successfully with the men, things, and activities which surround him.

## THE ECONOMIC VALUE.

Now, one word more on the secondary object, the economic. Some have not only failed to recognize the great educational value of manual training, but they have, as it seems to me, taken a too narrow view of its economic bearing. For instance, in analyzing the economic value of our shop-work and drawing, Dr. Harris does not appear to think them of value to the farmer. Remember, it is not proposed to substitute manual training for any of the schooling the farmer's boy now receives. I cheerfully grant that all he gets is of value. I say, add the manual training to his present curriculum. Will he not be the better farmer? Will it be of value to him to know how to repair a window, to hang a door, to plan and frame and erect a barn, to mend his plow or harrow, to supply a bolt or nut or a missing link on his reaper or mowing-machine, or to keep in order a windmill or a farm-wagon? You will surely agree with me, that, to be successful, a farmer must join the skillful hand to the cultured mind. I could tell you of many instances in which my own graduates have astonished the natives by stepping forward on an Illinois farm, in the presence of half a score of able-bodied men, and speedily mending a break which had threatened to entail a half-day's idleness for the whole force.

I recently heard of a successful dentist in New York, who attributed his success to the training he had received when a boy in a general repair-shop. Again, a noted surgeon says that his ability to make his own tools was the basis of his success. A graduate of mine went into a factory for turning corn-cob pipes and stems, in Washington, Mo. In a few days he ranked with any of the fifty men in the shop. Then he saw a possible improvement in the tools to be used. With a new tool, which he made himself, he was able soon to about double his productive power.

The habit of working on an exact plan, of analyzing an apparently complicated operation into a series of simple steps, enables one to solve many a new problem, even with new material and under entirely novel circumstances.

## THE MORAL INFLUENCE.

A word in regard to the moral effect of our combination. Its influence is wholesome in three ways: —

1. It stimulates a love for intellectual honesty. It deals with the substance, as well as with the shadow; it gives opportunity for primitive judgments; it shows in the concrete, in the most unmistakable form, the vast difference between right and wrong; it substitutes personal experience and the use of simple, forcible language, for the experience of others expressed in high-sounding phrase. It associates the deed with the thought, the real with the ideal, and lays the foundation for honesty in thought and in act.

2. The good moral effect of occupation is most marked. No boys were ever so busy as ours, in school and out. Every strong, healthy appetite finds its appropriate food. The variety of the daily program, far from confusing, produces a balance of healthy interests; and not only the boy's time, but his thoughts, are devoted to the work of the school. The correlation of drawing and shop-work with science and mathematical studies is exceedingly helpful on both sides, and parents testify to the absorption of our pupils in their work. Mothers and sisters are never tired of telling of the great convenience of having in the house one who has common sense enough to use the universal tools and to keep things in order. The hands are rarely idle enough to allow the devil to get in his mischievous work.

3. A third moral benefit is self-respect and a respect for honest, intelligent labor. A boy who sees nothing in manual labor but mere brute force despises both the labor and the laborer. To him all hand-work is drudgery, and all men who use their hands are to him equally uncultivated and unattractive. With the acquisition of skill in himself comes a pride in its possession, and the ability and willingness to recognize it in his fellows. When once he appreciates skill in handicraft or in any manual art, he regards the possessor of it with sympathy and respect.

Without going into the perplexing questions of labor and

capital, I feel sure that the only way to prevent such conflicts in the future is to properly train the children of the present generation. The men who make up mobs are deficient in either mental or manual training, or both. They never had a chance to get both side by side in a public or private school.

#### DIRECTIVE WORK.

But there is a higher view of even the economic side of the question. Mr. Edward Carpenter, speaking to the people of England of what Englishmen must do if they are to maintain their position at the head of the industrial world, thus refers to what we have called "directive" power.

"Administrative work has to be done in a nation as well as productive work; but it must be done by men accustomed to manual labor, who have the healthy decision and primitive authentic judgment which come of that, else it cannot be done well. Above all things, have done with this ancient sham of fleeing from manual labor, of despising, or pretending to despise, it."

But some one will tell me that there is nothing new in manual training, that there have been countless manual labor experiments in this country, which have always failed, and that throughout Europe industrial schools have been in successful operation for thirty years. Now, those who thus object do not recognize essential differences. Let me clear up this very important matter.

The so-called

#### "MANUAL LABOR" SCHOOLS

have been founded as semi-charitable institutions. They have been attempts to solve the problem, How shall a poor boy be enabled to earn his living and get his education at the same time? In my judgment there is no solution to that problem. We ought at once to recognize the fact that a good education costs money, and that every time we attempt to shift the burden of support upon children under seventeen years of age, we are guilty of cruelty and neglect. Of necessity, the form of labor adopted in these labor schools is that which involves a minimum

of training and skill and a quick return. The pupils learn some of the elements of a narrow occupation; but, on the whole, their education, whether mental or manual, is between very narrow limits. Such institutions have few points in common with a manual training school.

As to the

#### INDUSTRIAL SCHOOLS

of Europe, we all know they are intended to foster certain established industries. In a strictly "industrial" school, a single industry is taught, and with the definite and perfectly well understood object of making artisans in the industry taught. In Europe there is no feeling against such institutions, nor would there be here in a commercial establishment. In Europe the son of a miner goes to the mines, as a matter of course; and the son of a weaver has generally no hope beyond the loom. Except in rare instances, the child of a European laborer runs smoothly in grooves cut for him before he was born.

In America the case is quite different. A public school must put no bar to a boy's development; the upward roads are always to be left open. A public "trade school" in America would be out of place.

#### APPRENTICESHIP SCHOOLS.

There are in Europe many apprenticeship schools, which are generally of a higher grade than the industrial, and which have a somewhat broader aim, though in every case the definite object is to make every boy who attends, no matter what his natural aptitude, a skilled, practical mechanic. The literary and scientific training is in every case very limited, and the drawing is supposed to be directed to the wants of a single craft. As is too often the case with us, it is assumed that it requires no great amount of brains or intelligence to be a mechanic, and that intellectual culture is wasted on a man who finds employment for his hands. The broader aim I spoke of consists in furnishing a year of somewhat general training in which a boy may test his liking for several trades, one of which

is to be selected at the end of the first year. They have no place for one who does not wish to enter upon a special trade. During a visit last May to an excellent apprenticeship school in Paris, after visiting every shop, drawing and recitation room, and inspecting the daily program of each section, I suggested to the director that I saw no provision for one who should prefer a general course for the entire three years. He wheeled upon me with the emphatic reply, "This is a school to make mechanics. Every boy here must be a mechanic. He must earn his living by his trade the moment he leaves this school."

Now, neither the American manual labor school, nor the European industrial school, nor the apprenticeship school comes very near the manual training school. With them either self-support or a trade is the great, and nearly the sole, end. The trade schools have a worthy end, and they are successful. They have greatly improved the grade of technical skill in Europe, and they have accomplished much for their industries. I have no opposition to make to them, but I wish it to be well understood that a manual training school is quite a different thing. Instead of the two grand objects we have in view, — one general and educational, the other economic, — they have but one, the economic.

We do not claim to teach trades. In our school the manual elements are subordinated to the intellectual. One hour of drawing and two hours of shop-work daily is the maximum demand on the manual side. On the other side, there are three recitation hours and private study enough to learn three lessons.

#### TWO FALLACIES.

Two old fallacies have stood in our way, and they stand yet in many minds. One is that all the manual arts, except penmanship and free-hand drawing, should be learned at home or in connection with some business establishment. They always have been so learned, it is urged, if learned at all; and there is no good reason to suppose that they can be acquired to any useful extent in any other way. Certainly they can not be taught in school.

There is little need for me to answer this objection. It has

been answered in many ways. It has been proved a hundred times that the logical methods of the schoolroom are as applicable to the theory and use of tools and implements as to chemistry or algebra or book-keeping, and that no business establishment is willing to train a boy solely in the boy's interest. Superintendent MacAlister of Philadelphia says that needlework (i.e. plain sewing) is more logically taught than is arithmetic in his school. I can say as much for what we teach at the bench, the anvil, and the lathe. I have yet to find one person who has looked closely into this matter, who does not agree with me in this.

#### THE FALLACY OF SELF-SUPPORT.

The other fallacy is, that the moment one introduces manual training he must bring in the idea of self-support. The notion is inherited. Every apprentice boy, every counting-house fag was supposed to pay for his training by his labor. So every stranger who looks in upon our school asks what we do with the boys' work, and can we not make things to sell.

They forget, in the first place, that one's first results in a new field, where intelligence is necessary, are always valueless; and, in the second place, that the more an establishment is a factory, the less it is a school. No attempt has ever been made, to my knowledge, to make a school of penmanship, or English composition, or surgery, or medicine, or law self-supporting.

In a manual training school, everything is for the benefit of the boy. He is the only article to be put upon the market. We can not afford to turn out anything else. Time and opportunity for growth are too precious. The moment a class has learned fairly well how to make bolts and nuts, or to cut and solder a tin funnel, the boys must move on to master some new and unknown process, instead of stopping to make bolts and funnels for the market.

#### RELATION TO CRAFTS.

Now, as to the relation which our instruction bears to the crafts in most frequent use. During the total allowance of three hundred and eighty hours, which, in the first year, every boy of the class must devote to wood-work, the boys are learn-

ing some of the preliminary steps and essential features of several wood-working trades. The sharpening of chisels, gouges, bits, and planes; the filing and setting of saws; learning to square up and lay out work with precision; the cutting of mortises and tenons; the details of nailing, glueing, pinning, and dovetailing; various kinds of inside and outside turning, chucking, and fitting, etc., — all these belong equally to the cabinet-maker, the chair-maker, the pattern-maker, the wheelwright, the house-carpenter, the stair-builder, the cooper, the car-builder, the wood-carver, and so on. While thus learning the intelligent use and care of tools and materials, our boys become very proficient in making and using what are called “working drawings.” This last accomplishment is essential to intelligent progress in any trade.

The training given during the second year of school in the forging shop is equally fundamental and equally broad in its application. The study of form as related to strength and economy of material; the operations of drawing, upsetting, bending, punching, breaking, welding, tempering, braising, and soldering are fundamental in character, and preparatory to a score of distinct occupations, the special business and conventional details of which we do not pretend to teach.

Our machine-shop, in which the third-year students spend their three hundred and eighty hours of shop-time, is quite appropriately named. To be sure, there are benches where regular exercises in chipping and filing are done, but the greater part of the attention is given to the study, use, and management of machines. To this end machines with great range of adjustment, and always requiring precision and the exercise of forethought and good judgment, are employed. The materials wrought are those of which machines are generally made; viz., iron, cast and wrought, steel of various grades, and brass. Their cutting-tools the students generally make for themselves at the forge. We have in all twenty-one iron cutting-machines. It is no small thing to be able to use all these machines intelligently, not to say skillfully; and in this age, when many new machines are to be made, and all sorts of machines are to be used in the arts, there can be no surer way than ours of develop-



ing that "directive power" which is generally conceded to be one of the chief fruits of a good education.

Now, whether our boys become mining or civil or mechanical engineers, farmers or mechanics, merchants, manufacturers, lawyers, or statesmen, it seems clear that this training will give them additional power, both in molding circumstances and in their intercourse with men, taught and untaught, skilled and unskilled.

#### THE COST.

A single word as to the cost. I do not recommend manual training because it is cheap, or because it will result in an immediate saving of money. In the long run, it will save much money; but its establishment and maintenance are expensive. To begin with, a building with schoolrooms and desks, drawing rooms and stands, shops and tools, costs more than one with only schoolrooms and desks. Our working sections have from twenty to twenty-four students each, and for each section there must be a teacher. In the St. Louis school, there are two hundred and thirty pupils and twelve actual teachers. Again, the current expenses of shops and laboratories are considerable. In my school, it costs from five dollars to seven dollars per pupil per year for materials. But I strongly insist that the added value is worth the added cost, and that no community in which a manual training school has once been well established would allow its expense to be an argument against it.

#### EVENLY TRAINED BOYS.

I have said that the only article we put upon the market is evenly trained boys: I now wish to add that the article is a new one. You can not determine its value by invoicing the boys who in the past have drifted without proper education, and without intelligent choice, into shops and offices. I do not claim that manual training will change a dull boy into a bright one, or a bad boy into a good one; but it gives every dull boy, whether his dullness is in the direction of mathematics or language or mechanics, a chance to become less dull, and the bright boy a chance to retain his brilliancy. We have had some bad boys,

but I honestly think their badness was less corrupting than it would have been among boys less absorbed in their work. It is not safe to reason, that, because a boy can not succeed anywhere else, he must succeed in the shop. Brains are as essential in our school as in any school; as requisite to a thoroughly accomplished mechanic as to a good soldier or a good orator.<sup>1</sup>

Doubtless more than half of our boys will find abundant uses for their manual training, and they will have a marked advantage over the untrained boys. They are all fair draughtsmen. They have a wide acquaintance with hand and machine tools, and considerable skill in their use. They have an experimental knowledge of the properties of common materials, of the marvellous effects of heat, of the nature and amount of friction. Moreover, they have a fair command of English, an excellent knowledge of elementary mathematics, and are familiar with the first principles of natural science. They have analyzed mechanical processes, and learned to adapt means to ends. They have some knowledge of our literature, and generally of Latin and French grammars. Such boys will never become mere machine men. Do not associate them in your thoughts with that class of workmen, who, aside from the stock details of a single craft, have no cultivation whatever. They will never be content, whatever the vocation to which circumstances and their own fitness may call them, to put their brains away like a piece of ornamental toggery for which they have no daily use. They have many chances in their favor. They have fast hold of a ladder; which, with vigorous climbing, will carry them to the top.

#### HEALTHY EDUCATION.

It almost goes without saying, that the varied exercises of a manual training school are highly conducive to physical health. On the intellectual and moral sides, I hope I have shown that the effect must always be good. A training which enables a boy to make the most of himself, in a broad and high sense, must be regarded as healthy. A manual training school has many win-

---

<sup>1</sup> "There can be no greater fallacy than to imagine that any boy is too good for the workshop. Here is where brains are wanted." — PROF. RIPPER.

dows, and it looks out upon a large circle of human activities, and the kindling light shines in on every side. As with its windows, so with its doors: its pupils step into the busy world in all directions, each choosing a career where he may be reasonably certain of success. There are many avenues to culture and to success in life: we strive to keep them all open.

The system I advocate sets up no false standards: it does not mistake mere bookishness for generous culture; it teaches that neither the eye, nor the hand, nor the head can dispense with mutual co-operation and aid; it recognizes the actual claims of our civilization; it aims to elevate, to dignify, to liberalize, all the essential elements of society; and it renders it possible for every honorable calling to be the happy home of cultivation and refinement.

## CHAPTER X.

THE ORIGIN, AIMS, METHODS, AND DIGNITY OF  
POLYTECHNIC TRAINING.<sup>1</sup>

MILTON describes a complete and liberal education to be that "which fits a man to perform justly, skillfully, and magnanimously all the offices, private and public, both of peace and war." And in a letter to his friend Samuel Hartlib, he traces out a course of study for the "noble and gentle youth" of England, which he "guesses is likeliest to those ancient and famous schools of Pythagoras, Plato, Isocrates, Aristotle, and such others, out of which were bred such a number of renowned philosophers, orators, historians, poets, and princes;" but, avoiding the errors of both Sparta and Athens, of which the former trained her youth exclusively for war, the latter for the gown, Milton would train them equally for peace and for war. Admirable as is his statement of the object of education, — and it may be accepted as sound for all time, — Milton evidently thinks his course of study adapted to the wants of only a small and select class, and he is very severe upon those who should attempt his course without carrying it well through. He says that, "though a linguist should pride himself to have all the tongues that Babel cleft the world into, yet if he have not

---

<sup>1</sup> Address given in the hall of Washington University, Oct. 24, 1873. This address is inserted for three reasons: —

1. The dignity and general value of polytechnic training is still a matter of discussion, and the arguments presented seem to me as timely as when the address was written, nearly fourteen years ago.

2. It presents very clearly the necessity for manual training on the part of all children, outside as well as inside the polytechnic school.

3. This address, taken in connection with the two chapters which follow, clearly shows how, little by little, our ideas of manual training have matured under the discipline of actual experience.

studied the solid things in them, as well as words and lexicons, he were nothing so much to be esteemed a learned man as any yeoman or tradesman competently wise in his mother dialect only." Milton's letter was written some two hundred and thirty years ago; and, though his plan of study may have been excellently adapted to the "noble and gentle youth" of his day, it is well-nigh outgrown and obsolete now. The great storehouse of wisdom is no longer the ancient, but the modern tongues. Then he needs must look across a gulf of nearly two thousand years to the golden ages of nations, now no more, for his model heroes and poets and philosophers. We, living in a new era of progress, find abundant use for all our powers in striving to grasp the wisdom and genius of the present age.

Milton recognized but five professions open to educated youth; viz., those of the theologian, the lawyer, the statesman, the soldier, and the gentleman, — the last being defined by him as one "who retires himself to the enjoyments of ease and luxury." On the other hand, J. Scott Russell, one of the first of England's educated and practical men of to-day, enumerates in his plan of an English technical university, after excluding theology, law, and medicine, *twenty-two modern professions*, for which, in some way, education is to be provided.

It was formerly supposed that the manufacturer, the miner, the builder of houses or bridges or ships, the millwright, the farmer, the man of commerce, etc., needed no education beyond that gained by actual work at their trades or desks. Now, however, such strides have been taken in all these callings, through the application of the principles of modern science, that none but carefully trained and educated men can expect to secure and keep places of honor and profit in them.

Referring to the recent growth of scientific knowledge, which has been at once the cause and the consequence of the great increase in the number and scope of the different professions, Prof. Helmholtz says in a recent lecture, "We see scholars and scientific men absorbed in specialties of such vast extent, that the most universal genius can not hope to master more than a small section of our present range of knowledge." Philologists, in the place of Latin, Greek, and Hebrew, with two or three

European languages, aim now at nothing short of an acquaintance with all the languages of the human family. "The zoologists of the past were content to describe the teeth, hair, feet, and other external characteristics of an animal, while the anatomist never went beyond the human frame. To-day we have added comparative anatomy and microscopic anatomy, both of them sciences of infinitely wider range, which now absorb the interest of students." The four elements of the ancients and of mediæval alchemy have been increased to sixty-four; and so far have the methods of chemical analysis and synthesis been improved, that "what is called organic chemistry, which embraces only compounds of carbon with oxygen, hydrogen, nitrogen, and a few other elements, has already taken rank as an independent science." The one thousand catalogued stars of the seventeenth century have grown to two hundred thousand in the nineteenth; while in the department of physical dynamics, with the aid of a higher mathematical analysis which was totally unknown to the ancients, a whole world of knowledge, greater than any ancient Greek ever dreamed of, lies fresh opened before us. The contemplation of these things may well make us stand aghast, and exclaim with the chorus of Antigone, "Who can survey the whole field of knowledge?" The obvious consequence of this vast extension of the limits of science is that every student is forced to choose a narrower and still narrower field for his own studies, and can only keep up an imperfect acquaintance even with the allied fields of research.

It is thus made obvious that there must be an election of a course of study with each new student. No one curriculum can be suited to all. Our offices in life will be many and diverse; and if we would perform them "justly, skillfully, and magnanimously," we must actually choose our courses of training and study, and of course we shall choose them very differently. The arts are not one, but many; and every art is based upon a science, real or possible; and every science should have place in some course of study. Hence the university of to-day must teach and foster many arts; in short, it must be a polytechnic school.

I hope I have thus made clear the necessity in our generation

of polytechnic schools; and you will, perhaps, be surprised that we did not have them earlier. But educational institutions are eminently conservative; and, besides, the popular mind still had faith in the universal practical value of Milton's ancient school, long after shrewd, far-seeing business men were convinced of the need of some change. It required the irresistible logic of facts to convince the world that our old systems of education were, for the most part, outgrown. . . .

#### GROWTH OF EDUCATIONAL IDEAS.

But what has been the condition of things in the United States during this growth of ideas in England and on the Continent of Europe? Certainly we have not been idle or unconcerned spectators. To a certain extent we have been whipped over England's back; and tho we have always prided ourselves on our enterprise and "smartness" as a manufacturing people, and have glorified ourselves not a little over our great system of free public schools, and on our numerous high schools and colleges, we have been forced at last, not only to go across the Atlantic for the finest specimens of manufactured articles, but to look to Germany and France for guidance in educational matters. You know it is not, in general, a recommendation to say that the goods we are examining are of American manufacture, and that, as to education, the school system of Prussia is thought by many to be the best in the world.

We have confessed again and again, to each other, that our vaunted school system has not produced the results we sought. We aimed at one thing; we have secured another. We wanted an education that should develop the whole man; all his intellectual, moral, and physical powers should be drawn out, and trained and fitted for doing good service in the battle of life. We wanted wise heads and strong, skillful hands. There has been a growing demand, not only for men of knowledge, but for men of skill, in every department of human activity. Have our schools and colleges and universities been equal to the demand? Are we satisfied with what they have produced? Or are we compelled reluctantly to admit, that, after filling to overflowing the three traditionally learned professions, they

yield little else but candidates for Milton's class of "gentlemen," inasmuch as they are fitted for no kind of work, and consequently must spend their lives in ease and enjoyment if it be possible? Fortunately, there is no place for them in this busy land, where every one must be a working factor; and so they are driven, later in life, by sheer necessity, to learn the lesson which their faulty education had failed to teach; viz., the art of being useful. Do you wonder that our workmen are dissatisfied and unskilled, and that our products are third-class?

#### FAILURE OF OUR SCHOOL SYSTEM.

Says Mr. H. K. Oliver, in a letter to the *Boston Transcript*, dated the fifteenth day of August: "Our system [of education] trains boys not to become better craftsmen, but to be unwilling to be put to any kind of craft. Such ought not to be the effect of education, understood in its relation to our people. But a very small proportion can be of the so-called learned professions, and most of us must be of the productive, toiling class; and, while the mind should be justly cultivated, that the future workman may be able to read understandingly, to think wisely, and to express his thoughts well, to keep his business records, to apply his knowledge of the science of form, and to be guided by the forms of Christian morality, the main business of his coming life should receive at least some degree of attention. . . . The actual influence of our method of education is to make our youth in reality revolt from manual labor; they shrink from entering upon lives wherein physical labor is to be their means of living."

Hence, as has so often been said, nearly all our skilled workmen are imported. Our best machinists, miners, weavers, watchmakers, iron-workers, draughtsmen, and artisans of every description come from abroad; and this is so, not because our native born are deficient in natural tact or ability, nor because they are, in point of fact, above and beyond such occupations, but because they are really below them. So long as we endeavored to train up all our youth to become philosophers or philologists or doctors of something, those who did not look forward to such careers saw little or nothing of either pleasure or profit



in continued study, and so dropped out to join the great army of those fitted for — nothing!

· OLD STYLE EDUCATION USELESS.

I am speaking of admitted facts. Three out of four, if not nine out of ten, of the boys in this city to-day are growing up to manhood without being specially trained for any sort of trade, business, or profession. This seems to me almost criminally wrong on the part of us who are to any extent in charge of educational matters. My opinion is (and, if you will consider it for a moment, you will all agree with me) that every young man (and perhaps every young woman, too) should receive special theoretical and practical training in some one respectable trade or profession. Why is not this done? It is not because we have not the means. St. Louis is wealthy enough to give every one of her children a good intellectual and technical education, and then she would be wealthier still. Whatever may be the reason, the fact is, that the education offered, beyond the rudiments and elementary studies, does not seem to be just what is wanted. It is not attractive to pupils, or it is out of their reach; or parents and business men are of the opinion, secret, perhaps, but firmly held, that a higher education oftener *unfits* than *fits* a man for earning his living.

To be sure, statisticians will tell you to a cent how much the ability to read and write adds to the laborer's daily wages; how much, the ability to cipher and keep accounts. Possibly, also, they will give you the market value of the knowledge of elementary mechanics and 'line-drawing'; but you soon find a point where such statistics stop, and I fancy that it would not be difficult to prove that there is a point in our secondary or higher institutions of learning where the average boy's commercial value is *not* enhanced by a continuance in the old course of study.

· CRITICISMS.

Perhaps you will think that I am both unjust and ungenerous in these criticisms. If my statements and inferences are false, they are certainly unjust. If they are true, generosity does not require me to shrink from their utterance. I know

that the value of an education can not be estimated solely on a money basis; but I maintain that we have no right, in a community like ours, to ignore the pecuniary value of knowledge and skill. The love of money may be the root of all evil; but, after all, money is the most potent instrumentality we have of practically doing good.

Prest. Barnard of Columbia College has shown that the number of young men from New England and New York attending the regular colleges has been steadily diminishing of late years; and Mr. W. T. Harris of this city, in a recently published article, assumes, as a generally admitted fact, that the graduates of high schools less and less seek the training and culture which a college affords. In a time like the present, when the limits of human knowledge are rapidly receding on all sides, how can this important fact be explained, except on the ground that the college only partially meets the educational wants of the time, and that schools more in accord with the scientific spirit of the age are demanded?

#### POLYTECHNIC SCHOOLS.

I conclude, then, that our need of polytechnic schools has been demonstrated abroad and felt at home. The reaction against the old *régime* has already begun, and we can see the revolution going on. In every case of the establishment of a genuine polytechnic school or department, new courses of study and instruction have been arranged, requiring, when thorough, even when in connection with a college, the appointment of a separate faculty. These courses of study in general omitted the classical, philological, and historical studies of the college curriculum; retained a modern language or two, English composition, and political economy; gave a greater share of attention to mathematics and the natural sciences, and added such technical or professional work as could be crowded into courses of study generally four years in length. Thus the work required was fully equal in amount to that in the college course, but differed from it essentially in character. I will here quote one of the founders of the Worcester Free Institute. He says: "I have no intention of establishing here a rival of, or a substitute

for, the college. It is specially designed to meet the wants of those who have no desire for classical training, but who wish to be prepared, either as mechanics, civil engineers, chemists, architects, or designers, for the duties of active life." It may be said, that, in certain sense, the Worcester Institute has proved itself to be both a formidable rival of, and substitute for, the college.

In selecting the technical and professional work to be done by the students of a polytechnic school, we have been guided partly by the experience of older similar institutions in Europe, but chiefly by the obvious needs of our own people.

The first great want was for civil engineers, who should locate and construct the vast net-work of railroads, which continually grows thicker and closer all over our land, with their thousands of bridges and tunnels. Our school must, therefore, have a special course of work and study in civil engineering.

Then chemists were wanted, — men skilled in the analysis of soils, ores, manures, poisons, noxious gases, and the various products of industry. We have gas inspectors, milk inspectors, and water inspectors, each of whom must be an accomplished chemist. Every manufacturing company, whether of iron or steel, or paint or soap, or refined sugar, has its chemist; and the sphere of the chemist's labors increases day by day. Our polytechnic school must, then, be prepared to give a thorough course of training in chemistry.

As soon as placer mining seemed exhausted, and the seekers for gold and silver found themselves face to face with huge mountains, in the grasp of whose mighty ledges the precious ores lay hidden, it began to be felt necessary to call in the aid of men sufficiently well versed in geology, mechanics, and machinery to wisely locate and superintend the working of vast mines, as well as skillful in the processes of reducing and assaying the ores. Then, too, the immense and rapidly increasing demand for iron turned all eyes upon our wealth of iron ores, and men were demanded trained in methods of developing them. Thus, without referring to our mines of copper, lead, zinc, and possibly *tin*, it will be at once perceived that our

school must be prepared to train and qualify the mining engineer and the metallurgist.

Meanwhile, there came from all sides calls for men skilled in machines and mechanism. There were engines and motors of all sorts to be built; machines of every conceivable pattern were to be constructed; and men were wanted trained in all the theories of mechanics, thoroughly acquainted with the nature and properties of the materials used in construction, and skilled in the use of tools. It was clear that our technical school should aim to educate and train, as far as possible, the mechanical engineer.

If we add to this list of technical courses of study that of building and architecture, which has thus far received but little attention among us, and some rather problematical experiments in the study of agriculture and horticulture, we have told about the whole story of technical education in the United States, outside of the government naval and military schools. In Europe more, vastly more, has been attempted, and much more has been done; but, although their experience in these matters is not without its value to us, it is carefully to be borne in mind that an institution admirably adapted to the people of France or Belgium or Prussia, or even of England, is not necessarily the one for us. Our social frame-work is quite different. With us, every boy is a natural candidate for the office of president, and no one shall dare to place any bounds to his aspirations and his social possibilities; so that a man generally spends half his days in finding his proper level where he can settle down to contented, steady work. In Europe, except in rare instances, he runs smoothly in grooves cut for him before he was born.

#### INDUSTRIAL TRAINING IN EUROPE.

Hence, it is possible and even necessary for them to establish industrial schools for children at an early age. In these schools the children are occupied in all about nine hours per day. In the morning and during an hour in the evening they receive instruction as in a school. During the middle of the day they work at the trade, whatever it may be, under the direction of those who teach them the *rationale* of the art. In schools like

these, which originated in Belgium and France, instruction is given in the arts of designing, engraving, coloring, dyeing, silk and ribbon weaving, lace-making; of making mathematical instruments, of stone-cutting and wood-carving, of glass-work, and light kinds of metal-work. The education thus gained is often all the children get. The schools are filled with the children of laborers and operatives, who, having been early destined to this particular trade, look contentedly forward to being workmen and operatives themselves.

Such schools, beyond their establishment in connection with charitable and reformatory institutions, are obviously impossible in this country, at least for the present; but there seems to be no reason why our primary and secondary, public and private schools on the one hand, and our polytechnic schools on the other, can not be so modified that they may be able to accomplish between them all that is desirable to attempt to do in competing with the trade products of Europe. I say all that it is desirable to attempt, for I do not consider it at all worthy of effort to attempt to compete with many of the hand-made products of European industry. I would as soon attempt to rival the deft and patient inhabitant of India in the manufacture of Calcutta toys and camel's-hair shawls. The coming age is to be, even more than this, an age of machinery. The Waltham Watch Company in Massachusetts, and the Elgin in Illinois, indicate the true course for American industry to take. All the works of their watches are machine-made, and hence they are able to undersell many of the established watch-makers of Europe, whose work is mostly done by hand. Give us a better knowledge of physics and chemistry, a knowledge, so to speak, that is at our fingers' ends; give us new and improved and finished machinery, and with it some training in the theory and practice of mechanism, and we will challenge the competition of the world.

I have referred to the want of confidence in the value of our old system of education beyond the most elementary work, and it is just to note the changes now taking place which seem to be wisely made. I observe the introduction of natural science studies into the programs of all grades of the public

schools, and into the highest the introduction of free-hand and mechanical drawing, and other studies strictly preparatory to a polytechnic course of study. Thus do the higher technical and professional schools, in proportion to the clearness with which they define their work and then maintain their standards, exert the influence which higher schools always exert upon lower and preparatory ones, and mold them into an improved pattern.

#### SCIENTIFIC *versus* CLASSIC CULTURE.

Before I proceed to speak of the methods of a completely organized and thoroughly equipped polytechnic school, I wish to say a few words in defense of the dignity of a technical education, and upon the value of scientific as opposed to classical culture.

The infinite range of human knowledge, as was remarked before, compels each student to select a course of study relatively narrower and narrower. To speak allegorically, we start out in our educational career together. As yet we have no notion of where our path will lead: we seem to be all travelling the same road. We learn to speak and read and write our mother tongue. We learn enough of this earth of ours to tell our latitude and longitude. We catch a few glimpses of the field of mathematics, and then our journey becomes more difficult. We grapple with hard problems; we breathe invigorating odors; we climb sharp precipices; we press blindly through thickets to the glimmering lights beyond; we fall, and try other paths, till at last each sees a straight course before him. He looks for his comrades, but they are all gone. We are threading our several narrow paths alone. Of course, each is sure he is on the right road, and that the rest are more or less astray. Perhaps I find my path leading through classic fields. The way is rough with Greek roots, and blocked up with dialectic forms. On my right I see the yellow Tiber, rolling by the temples of the gods, near which I see the toga'd Cicero swaying the people with his eloquence. I see the gentle Virgil chanting his thrilling lay in the halls of the Cæsars, while Livy is embellishing history for the glory of Rome. On my left I

see the Olympian mountains, the groves of Athens, and the thronged Acropolis. I behold Demosthenes lashing the Greeks into a frenzy of rage against Philip of Macedon. A crowd is rushing to the theater, to be thrown into a whirl of passion by a tragedy of Euripides, or convulsed with laughter by a comedy of Aristophanes. A blind bard is singing from house to house the wrath of Achilles, the fall of Troy, and the woes of the brave Ulysses; while in a quiet garden, with a small band of pupils, Plato and Aristotle walk in the cool retreats, discussing life, duty, the causes and the ends of things.

What a world of beauty and wisdom lies before me! I will press on to these Elysian fields, and drink at these classic fountains. A feeling of pity springs up in my self-satisfied heart for my companions of yesterday, who have lost their way, and who are wandering on in other paths. I call aloud and listen. From afar come up the cheery cries, as of men not lost, but victorious. I charge them to come with me. *I* am on the right road. They answer that *I*, not *they*, have strayed.

In the dim distance I see one digging in the bowels of the earth, and taking therefrom what looks like dross, but from which he, with fervent heat and colored flame and strange mixings, brings a wealth of precious and of useful ore.

Another is absorbed in the study of the laws of motion, force, and strength; and, as if by magic, he is rearing a crystal palace, marvelous for grace and lightness, rivaling in beauty the very Parthenon itself.

Another, amid the war of mighty engines, which in smoke and flame eclipse almost the mighty *Ætna*, and in the glare of forges and the clang of hammers such as *Vulcan* never saw, is training eye and hand and brain for the fabrication of a maze of strange machinery.

Another is studying the life and growth of plants and trees and crops; another, the races of animals, their structure, origin, and development; another observes the laws of trade, of society, of wealth, of justice, and of the mind itself.

I vainly urge them to follow me. I tell them of the sages and orators and poets of ancient Greece and Rome. They echo back the names of *Newton*, and *Leibnitz*, and *Faraday*, and

Liebig, and Goethe, and Shakespere, and Rumford, and Helmholtz, and Darwin, and Maxwell, and Tyndall, and Agassiz, and Watt, and Stephenson.

Some of these names I know. Many I never heard of before, as their names are not in my lexicons; but I am certain that some are men of no classical culture, and are only concerned in the study of very common things. None of us will be persuaded to abandon his course, and so we go on our several ways with mutual sneers of contempt. We are all amazed at the stupidity and want of judgment which people *do* show on educational matters.

#### LIBERAL EDUCATION.

But let us return from our journeyings, and compare notes. It is obvious enough that all were right, and all were wrong. It would have been ruinous to the last degree to have all gone the same way. It is absolutely necessary to the world's progress that we travel by different routes. The labor of each but complements the labors of all the rest, and one has no more right to scorn or underrate another who has been equally engaged in honest, faithful work, than has the eye to scorn the foot, the foot the hand, or the hand the ear. Therefore we will not call my education liberal, and yours illiberal; but each shall respect the other's attainments, and rejoice that the day for cutting out a generation all on the same pattern has passed away. All training, to be thorough, must be special. General culture means, and must inevitably mean, a little of every thing and nothing deep. The man who lays claim to all knowledge is at once put down as a conceited quack. The man, on the contrary, who modestly limits his pretensions to one science or study, claiming only an imperfect acquaintance even with the closely related sciences, may be regarded as an accomplished man. There is an old proverb which is full of wisdom: "Beware of the man of one book." That is, he who has read, and re-read, and read again, one good book, is more to be feared as an adversary than he who has hastily and carelessly read scores. So in matters of science. Let one master thoroughly one science,—i.e., up to the present limits of knowledge; no matter whether it be mathematics, or chemistry, or thermodynamics,



or political economy, or physiology, — and he is a man to be looked up to and feared. He has incidentally learned much of cognate matters, but above all he has learned the method and reach of scientific study. All the activities of life are based upon scientific principles; and not only our usefulness, but our happiness, largely depend upon the amount and quality of our knowledge of these underlying principles.

But, you ask, how shall we choose for ourselves and for our children? By pointing out so many paths, you only add to our perplexity. Shall we follow the old, well-worn path our fathers trod? Shall our children spend six or seven years in studying Greek or Latin, or Hebrew and Sanscrit, or shall that time be mainly given to modern languages, to mathematics and the physical sciences? This is a hard question, and every one earlier or later must ask it. Remember, there is no single universal answer. I might decide in one way, you in another. Fortunately, we disagree; and men everywhere, men renowned in science and art, in literature, ancient and modern, differ in naming the *one* course to be pursued. . . .

#### EDUCATION OF INTRINSIC VALUE.

Thus you see that the old bands are broken, that there is no royal road to culture or scholarship. Latin and Greek are, very properly, the *sine qua non* of the college curriculum, but they have lost their claim to a monopoly of the words of wisdom and worth. Henceforth, students will “elect” a classical course, as they would chemistry or natural history; and a thorough knowledge of the language and literature of ancient Greece and Rome will be regarded as much a specialty, as civil engineering or practical astronomy.

I have said more on this point than I should have done, had I not of late noticed a strong tendency on the part of the friends of one or another of these rival courses of study to sneer at the others. It is very easy to deny Prof. Tyndall's claim to the title of an educated and cultivated man, because, forsooth, he has never studied Greek; and it is equally easy to retort (as has also been done) that, as a rule, those who have spent so much time and labor in studying the ancient tongues,

are notoriously ignorant and unskilled in the use of their own. But all this is wrong. One must be content to be ignorant of much that others know; and, so long as he has really attained to knowledge and skill in some path of usefulness, he should feel that he has not forfeited his claim to respect and fellowship. As to the question, which course of study shall you pursue, I can only say, that, in my judgment, the knowledge which it is best for you to have is the best for you to get; there is no divorce between wise possession and rich experience in acquiring, between the best ends and the best means. As Dr. Wayland, in substance, says, "It is the intention of the all-wise Creator that all intellectual culture shall issue to knowledge that is of the greatest intrinsic value; and that all useful knowledge, properly acquired, tends equally to intellectual development."

#### CHARACTERISTICS OF THE POLYTECHNIC SCHOOL.

This distinguishing feature of a polytechnic school, next to the kind of knowledge it aims to give, lies in its method of combining theory with practice. Not only should a polytechnic school aim to give instruction in the scientific principles theoretically involved in every important branch of industry, but it should not be satisfied until the student himself is sufficiently familiar with the details of the processes in question, and sufficiently skilled in the necessary manipulations, to enable him to illustrate these principles himself. These two things characterize the ideal technical school, and mark the educational progress of this generation: First, the things studied and taught are of immediate importance and of intrinsic value; second, one is not supposed to understand a process or an experiment till he has performed it. You know how it is in music. I may be quite familiar with the mathematical and physical theories of music. I may have studied with Helmholtz the wonderful mechanism of the ossicles of the ear. I may be deeply read in the æsthetics of harmony and thorough-bass. I may even be able to explain the exact difference between a euharmonic and a common organ. And yet, if I can not *play*, I am no musician. Moreover, this playing on an organ is not

a manual accomplishment merely. The brain is more concerned than the fingers. It is so in every thing. What avails your knowledge of photography unless you can take a good picture, and of what worth is your engineering if your bridge will not carry its own weight, and you have designed an impossible engine? None but the wearer *can* know where the shoe pinches, and none but a man who has had some practice is prepared for practical difficulties. Prof. Tyndall says, "Half of our book-writers describe experiments that they never made, and their descriptions often lack both force and truth. No matter how clever and conscientious they may be, their written words can not supply the place of actual observation," and he might have added, "of actual manipulation." Theory and practice, then, must go hand in hand; and, in order that the practice may be adequate to the theory, the hand and eye and head must receive previous careful training,—the hand in the use of instruments and tools; the eye in measuring distances and angles, in detecting peculiarities of form, and in observing the details of a construction; the head in a knowledge of the common properties of the commonest material substances, such as wood, stone, iron, glass, etc. The hand is a wonderful organ, and capable of performing vastly more than it is usually made to do. The same is true of the eye. Close observation is a habit which few acquire.

#### MANUAL TRAINING.

Children should early be taught to use, as well as to beware of, sharp tools. Just as every boy should be taught to swim, to row, to ride and groom a horse, so he should be taught to use the ax, the saw, the plane, and the file. Even a little skill in the use of these tools is invaluable. No one possessing manual dexterity of any kind fails to find abundant opportunity for its use.

I do not think I overestimate the value of physical strength, dexterity, and skill. It is in vain to assert the dignity of labor. Unless it has something in it besides dignity, we are not likely to be very zealous in seeking it. But skill we delight in. It is the exercise of skill which gives zest to all our games and

sports, and removes the curse of Adam. There is not a person before me possessed of unusual skill, — I care not whether it be in handling the carpenter's ax or the painter's brush, in playing the organ or in shooting game, in driving horses or in sailing a boat, in making bread or in fitting a garment, — who is not conscious of a feeling of gratification and pride in consequence. Carlyle says in his *Sartor Resartus*, "Two men I honor, and no third: First, the toil-worn craftsman," etc. It is obvious that it is the craft that he honors, and not the toil.

I therefore plead for a more extended and more systematic physical [manual] education. It is the best aid towards securing a wholesome intellectual culture, and it is the *only* means for making that culture of practical use. The world judges and rates us according to what we can *do*; and as an accomplished gymnast never loses his presence of mind, whether hanging by one foot or turning in mid-air, so a well-trained engineer is rarely at a loss. An acquaintance of mine, a young man well trained in both the theory and use of tools, and accustomed to *do things*, chanced to pass, in the city of New York, a gang of workmen endeavoring to move an immense iron safe. The unwieldy mass had partially slipped from their grasp, and all efforts to bring it again under control seemed to fail. Taking in the situation at a glance, my friend stepped forward and assumed the command. Clearly and without hesitation he gave his orders; promptly and willingly the men obeyed. In a moment the safe was well in hand, and expeditiously moved to its place. As the young engineer turned to go, a gentleman stopped him and said, "Young man, I will give you three thousand dollars a year if you will enter my employ and take the charge of moving our safes." Besides saying that the skill thus displayed was gained by study of the strength of materials and the mechanical powers, coupled with the actual use of tools in his own hands, I ought to add, perhaps, that the blunt offer was politely declined.

#### SHOP-WORK.

But the acquisition of this desirable manual skill requires workshops and tools and teachers; and, as such essentials are not in general to be had at home or at a common school, the

work must be done at a polytechnic school. Hence, at the earliest possible moment, in the lowest class, students must enter the workshop. From the bench of the carpenter they should go to the lathe. Wood-turning is an art requiring great judgment and skill, and any one accomplished in it will testify to its great practical value. After wood, come brass, iron, and steel turning, fitting, and finishing; then the forge, where each should learn welding and tempering. This is the alphabet of tools. Next will come their legitimate use in the manufacture of patterns for castings, in the construction of model frames, trusses, bridges, and roofs; in the cutting of screws and nuts with threads of various pitch; and in the manufacture of spur and bevel wheels, with epicycloid and involute teeth. This shop-work should extend through the entire course of four years, varying somewhat according to the professional course selected.

#### DRAWING.

Meanwhile, also, throughout the course, the student should study and practice drawing. Drawing is the short-hand language of modern science. Careful drawings are to technically educated people what pictures are to children. They show at a glance what it is not in the power of words to express. It is a universal language, and should be read and understood of all men. But drawing has another use of equal value. It is the most potent means for developing the perceptive faculties, teaching the student to see correctly, and to understand what he sees. Drawing, if well taught, is the constant practice of the analysis of forms, and by this practice the eye is quickened and rendered incomparably more accurate; and as the eye is the most open and ready road through which knowledge passes to the mind, the full development of its powers can be a matter of no small importance to all. In this respect, then, as an educator of the eye, drawing is a most valuable means, irrespective of any service that the power may be of itself. But there is another faculty engaged in this study, — that one which distinguishes man from the cleverest of the animals, — the hand is employed, and it also is educated and trained to be more completely under the control of the will than by any other exercise

it can be set to; it acquires a delicacy of movement and a refinement of power which no other discipline can impart, and which fits it more completely to perform its varied and delicate functions.

#### APPRENTICESHIP.

At Worcester we see young men actually learning a lucrative and honorable trade, while gaining a good knowledge of physics, chemistry, mathematics, mechanics, drawing of all kinds, French, English composition, political economy, etc. It may be well here to add, that, though the Institute receives quite an income from the sales of its manufactured articles, it is a fixed rule with the management that no student shall receive pay for shop-work done during the regular practice hours. Extra work, however, is paid for exactly according to its value. This Worcester Institute grows more and more popular every day, thus showing that it meets a popular want. To it young men more or less skilled in the use of tools, and with decided mechanical tastes, are flocking in increasing numbers. Not all will become mechanical engineers, or even machinists; but all are adopting one of the best means of making themselves independent of fickle fortune, and of making successful business men.

This feature of actually learning a trade is invested with a new interest in these days of co-operative societies and labor unions. You know that these unions regulate, or try to regulate, the number of apprentices which a shop may have. Hence it is often impossible for a young man to get a place to learn a trade; and sometimes, even when a place is to be had, it costs one, if not his life, at least his personal comfort and happiness, to accept it. You easily see how important a bearing upon our social well-being, in a city like St. Louis, this question of training apprentices is; but I can only refer to it here.

It seems to me that such an institution as the Washburn Machine-Shop should be made a feature of every polytechnic school. In the last bulletin from Prest. Runkle, of the Massachusetts Institute of Technology, he says, "We must have a machine-shop." The Stevens Institute of Technology at Hoboken, N.J., is mainly a school of mechanical engineering, and has a large machine-shop splendidly equipped. This noble

institution is due to the munificence of Mr. Edwin A. Stevens, who gave a square of land in his native city, erected a magnificent building at the cost of a hundred and fifty thousand dollars, and then gave as a permanent endowment the princely sum of five hundred thousand dollars. As it has been in operation scarcely two years, we can not quote its experience.

As for

#### THE POLYTECHNIC DEPARTMENT OF THIS UNIVERSITY,

I have time for but a single word. We have our chemical laboratories, where every possible experiment is tried with the greatest ease and nicety. We have our mining and metallurgical laboratories, where all the processes of smelting and assaying ores are carried on; we have very full and valuable cabinets of minerals and fossils; we have a very fair assortment of physical apparatus, and an excellent opportunity for the student in physics to put his theoretical results to the test, and to carry on his independent investigations; we have all the instruments used by civil engineers, and a very good collection of models. In addition to the above, we have, what is certainly worthy of mention, a small workshop, containing a single work-bench, two foot-lathes, a gear-cutter, and a forge. Small and inadequate as this shop is to the wants of our department, I hold it at no mean price. Our great want, however, lies in this direction: money! Did I hear you say that such things cost money? I grant it. Everything worth having usually costs heavily; but remember, I have proved that such investments pay, — if not in this generation, certainly in the next. The road to commercial prosperity lies through the door of practical, scientific training; and in these matters the great city of the West must not be behind her Eastern sisters. Give us our suite of workshops, our Washburn Machine-Shop, and we will call it by any name you please.

#### A NOBLE EXAMPLE.

It is a part of my duty — and I hope you consider it also a part of yours — to preach the crusade of a higher and better education, until no one shall need to be persuaded of the value of that whose price is above rubies. As to the other considera-

tion,—namely, that of rendering it possible for every young man desiring it to seek in a polytechnic school for that education which shall enable him the better to discharge his duties to himself and to others,—let me commend the royal example of Sir Joseph Whitworth, England's great mechanical engineer.<sup>1</sup>

---

<sup>1</sup> NOTE WRITTEN IN 1877.—Sir Joseph Whitworth, in 1868, when plain Joseph Whitworth, mechanical engineer, at Manchester, Eng., founded thirty "Whitworth Scholarships," worth five hundred dollars each annually. He was knighted the following year. For a similar wise and noble disposition of honorable wealth among us, we cheerfully pledge the honors of an *American knighthood*. Whitworth still lives to superintend with increasing satisfaction the disposition of his magnificent liberality.



## CHAPTER XI.

MANUAL EDUCATION.<sup>1</sup>

WHEN stated in general terms, the object of education has been the same in all ages, — the development of those powers and faculties which combine to form the ideal man of the age. But when we examine the ideals, the standards of excellence set up, we find them as different and as various as possible.

Among the Greeks this education was secured by the study of Homer and geometry, and by the culture of physical strength and beauty; the latter was gained by gymnastic exercises, by running, wrestling, boxing, hurling the discus, and handling the weapons of war.

The later Romans aimed to make poets and orators and warriors, and trained their youth in the study of poetry and eloquence, and in exercises which were typified in the bloody scenes of the arena.

A thousand years later, and the standard has again changed. Orators and poets have disappeared. In place of the naked foot-soldier, with a shield and short sword, we have a mounted knight, clad in steel, bearing a long and heavy lance. The youth are taught to ride and groom a horse, to run, to jump, to row a boat, to bear a lance, to shoot with a bow, to read and write, and to sing songs of love and valor.

Still later, when the invention of gunpowder had swept away forever that extravagant estimate of the value of physical strength and powers, when the invention of printing had spread throughout Europe the wealth of ancient literature, the standards of excellence and the methods of education turned back

---

<sup>1</sup> A paper read before the St. Louis Social Science Association, May 16, 1878.

again to the literature of the past. Pupils were taught to read and write the ancient languages. They studied Euclid, and memorized Virgil and Homer. Scholars wrote their essays upon literature, science, and art in the Latin tongue. Physical training gradually disappeared. The pen was found to be mightier than the sword: so the hand was taught to wield only the pen. The popular idea of excellence was embodied in a man of commanding intellect and extensive information, whose reasoning powers had been cultivated to the highest degree by the study of pure mathematics and the philosophy of the ancients. The practical side of life, with its thousands of material and physical problems, was looked down upon as ignoble and unworthy serious study. To-day the civilized world is re-acting from this one-sided standard. Systematic education, which in former times was limited to a select few in every land, has now become popular; and we are gradually learning that exclusively intellectual education is not exactly what the people want. The schools of Eton and Rugby, and the universities of Oxford and Cambridge, were perhaps well adapted to rear the scholars and statesmen of Great Britain; but they are not the schools in which to train all the children of London and Manchester.

I have said that the re-action has begun. It is, however, not so much a re-action as

#### A NEW DEPARTURE IN EDUCATION.

In the first place, the excellence of intellectual training is admitted, and the value of a certain amount of abstract mental discipline is recognized. In the second place, in returning to a just recognition of the importance of our physical powers and faculties, and of a practical knowledge of the properties and uses of material things, the new education trains youth to skillfully wield, not so much the weapons of war, as the instruments of peace; not so much the shield and spear and battle-ax, as the file and chisel and sledge; to drive an engine in the interests of trade and commerce and peaceful intercourse, rather than a chariot of war; and, if we still must learn the art of war, we would teach our youth to fashion and use the unerring breech-loading rifle, rather than the long bow or the short sword.

During the last hundred years the world has made rapid strides in the invention and use of tools. We do nothing with the unaided hand; everything is done by tools.

“Man,” says Carlyle, “is a tool-using animal. He can use tools, can devise tools; with these the granite mountains melt into light dust before him; he kneads glowing iron as if it were soft paste; seas are his smooth highway, winds and fire his unwearied steeds. Nowhere do you find him without tools: without tools, he is nothing; with tools, he is all.”

On the physical side, he is the greatest public benefactor who makes the best tools, and he is the best workman who can use tools best.

Since these things are so, it would appear that a proper system of education should include some training in the use of tools. Mr. Chaney, the president of the Boston Industrial School Association, says in a recent letter: “I advocate such training (the use of the half dozen common wood-working tools) as a part of the public-school system, on the ground that it is a necessary part of the education of every householder.”

#### INSUFFICIENCY OF THE PRESENT SYSTEM.

Nothing is clearer than that our present system of education is inadequate. For fifty years there has been a growing conviction that the education of the schoolroom does not cover the whole ground; that, however excellent the abstract intellectual discipline, however thorough may be the reading of written histories and the study of language, a great want is still unsatisfied. We want a fuller knowledge and a greater familiarity with the material world by which we are surrounded, through the medium of which we act for and upon each other and for our own physical well-being. A knowledge of material things and material instrumentalities can be gained only by close and systematic observation and study, and is in itself a liberal education. Consider, for a moment, to how great an extent the value of a man as a factor in society depends upon his exact information of the material world and nature's laws. The conclusions of the best theorizer are valuable only in proportion to

the soundness and completeness of his premises. Is a plate of rolled iron equally strong along and across the grain? Does wood, in seasoning, shrink equally in all directions across the grain? What shapes can, and what can not, be molded and cast? What is any one of the myriad facts of chemistry learned fully only by observation and experiment? Upon your answer to such questions, your practical usefulness depends. In your investigations upon such points, your brain will be as active as your hands. If you neglect to use either, you will be lame and impotent.

We all have two natures, one physical and one spiritual, bound together in a union so close that no man can draw the line of separation. If the material world is not the basis of the intellectual, it is certainly, as far as our human existence is concerned, the *sine qua non* of its growth and manifestation. The sound mind can be found only in connection with the sound body.

If this is so, sound reasoning would require their co-education.

#### THE CO-EDUCATION OF BRAIN AND HAND.

It was the fashion with certain fanatics once, and it is still an article in the creed of some, that we must mortify and despise this fleshly nature. This glorious frame, with all its wondrous mechanism, must be put to shame; the hand must lose its cunning, the body its strength and vigor, the eye its lustre, that the spirit alone may triumph.

To us these notions seem but the relic of a barbarous age, and yet they have burned themselves deep into our social constitution.

Our care must be, while developing and strengthening our mental faculties, and imparting some useful information, to cultivate the hands and arms and eyes, to give them strength, flexibility, dexterity, precision, and habits of prompt obedience to the will. These results come only from early training; while the body is growing and the mind is maturing, the joints are flexible and the muscles are tractable, the eye unprejudiced, and the mechanical judgment in a most teachable condition.

Wendell Phillips says: "The discrimination against those who prefer to work with their hands is very unjust. Our system of education helps the literary class to an unfair extent, when compared with what it affords to those who choose some mechanical pursuit. Our system stops too short; and as a justice to boys and girls, as well as to society, it should see to it that those whose life is to be one of manual labor should be better trained for it."

Says Anna C. Garlin, in the *New England Journal of Education*: "Let the child be taken to school whole, instead of in parts; let him be considered to have a body as well as a mind; let him be trained physically toward use, by a wise shaping of the eager animal activity; let him be protected from the cupidity of manufacturer and the pressure of home poverty, by utilizing the active energy, which in more primitive times was of so much account in the family economy; let him be gradually introduced into that hard world of work for which he is destined, by a training which shall be of the hands as well as of the brain. . . . If we are to protect the children of the very poor from the very worst consequences of their condition, without making paupers of them or their parents, we must continue (after the training of the kindergarten) in some way to give them study and work together."

Says Mr. J. P. Wickersham, Superintendent of Public Instruction for the State of Pennsylvania: "It is high time that something should be done to enable our youth to learn trades, and to form industrious habits and a taste for work.

"It is not enough to instruct a boy in the branches of learning usually taught in our common schools, and there leave him. It must be seen to by some authority that he is allowed a chance to prepare himself to earn a livelihood. It takes more than a mere knowledge of books to make a useful member of society and a good citizen. The present product of our schools seems to be, in too great a degree, clerks, book-keepers, salesmen, agents, office-seekers, and office-holders. We must so modify our system of instruction as to send out, instead, large classes of young people fitted for trades, for business, and *willing and able to work.*"

Here is the important point, — “*able and willing to work.*” A man who has been taught to work with intelligence and skill at once has a higher estimate of labor and laboring men.

Test this by referring to your own experiences. Have you a single physical accomplishment? If you have, you are proud of it. It may be that you are skillful in the use of the rifle or the ax, the file or the stone-mason’s sledge. It may be that you excel in handling the pencil, pen, or brush. Perhaps it is the needle, the violin, the piano, or only the cue. Whatever it is, you not only plume yourself upon your skill, but you have a high respect for those who are your peers, and a strong suspicion that few people have any idea of what skill like yours really means.

Prest. Runkle says: “Public education should touch practical life in a larger number of points; it should better fit all for that sphere in life in which they are destined to find their highest happiness and well-being. It is not meant by this that our education should be lowered mentally, but that it should be based, if possible, upon those elements which may serve the double purpose of a mental culture and discipline, — a development of the capacity of the individual with and through the acquisition of artistic tastes and manual skill in the graphic and mechanic arts which most largely apply in our industries. The student who completes his high-school course at eighteen seldom willingly enters the shop as an apprentice, with the intention of becoming a skilled mechanic and earning a livelihood by manual labor. His twelve or fourteen years of mental school-work, whether highly successful or not, have, through habit, if in no other way, unfitted him for all manual work, even if he has not in many ways been taught to despise such labor.”

#### CONTEMPT FOR MANUAL LABOR.

The average man is apt to despise and underrate an accomplishment which he, through lack of training or effort, does not possess. One who knows how to use tools well is rarely ashamed to use them; and he enjoys it, too. The ambitious young wife who “can not endure cooking,” and who scouts the

idea of making her own clothes, is simply unable to do either. The man who turns his nose up highest at the rough palm of the joiner, or the soiled fingers and greasy apron of a machinist, is generally one who can not tell steel from cast iron, and can not drive a nail into a piece of wood without splitting it. It is no wonder that such men despise labor of all kinds. Consistency requires it; to do otherwise would be a sort of confession of a personal mistake.

But opportunities to learn trades are very limited. Indenture and regular apprenticeship have passed away for ever. The ordinary apprentice of to-day is the butt and fag of the shop. No one takes a personal interest in him, nor feels any responsibility for his progress. He is kept drudging, and his progress in learning the craft is made secondary to his employer's interest. A majority of apprentices in the United States run away before their trade is fully learned, and set up the claim of journeymen with a view to getting better pay. This lowers the standards of workmanship, of honor, and of wages also. Apprenticeship in St. Louis to-day means long days, hard and often disagreeable work, poor pay, and the almost certain prospect of low wages and a narrow field of labor in the future. It is no wonder that boys of fair education shrink from it.

Another reason for shunning manual labor is the ambition to be rich. Wealth is regarded as a prize in a lottery, and the laboring men always draw blanks. Tho the good workman is much less frequently reduced to want than those who propose to live by their wits, the distant possibility of affluence through speculation or the shrewd management of the labor of others, the large salary or the enormous fees of the occasional professional man draw the infatuated crowd away as the song of the fabled siren did the voyagers of old. A single ten-thousand-dollar salary is liable to demoralize the entire youth of a community.

The tyranny of trade unions is felt in every trade. For the purpose of increasing the value of their own labor and skill, craftsmen combine to keep others out of their shops. Hence the sons of a poor journeyman often find it impossible to learn their father's trade, and are driven to habits of idleness and

vice. By threats of stopping work and reducing a factory to enforced idleness, the unions generally carry their point. By looking only at the relation which they sustain to their employers, and not at their social relations, these unions persuade the very people whom they most oppress of the justice of their course.

#### TRADE SCHOOLS.

Let us now see what steps have been taken to remedy these evils, and to better adapt our system of education to the present stage of civilization.

Through the instrumentality of our international expositions, we have become well acquainted with the progress made elsewhere in educational as well as other matters.

It is more than a hundred years since a school of trades was established in Russia. It is not a little strange that that far-off and strange people, whom we are accustomed to regard as occupying a somewhat lower plane of civilization, and who seem to have so little in common with other nations, should in practical matters have been twice our teacher. The special inspiration of this paper came from Russia.

The introduction of machinery, the division of labor, and the extensive competition incident to increased facilities for commerce, suggested both the possibility and the necessity of cheapening the cost of production, as well as improving the quality of the manufactured articles, by the systematic instruction of children in the bare details of a single trade, and their early introduction to the shops. Where the business of a community was largely of one kind, the trade school became an important item in the public economy.

Later, trade schools were established in Belgium and France, and thence they have spread throughout Europe. During the past twenty years, hundreds have been established. Their effect upon the manufacturing interests of the people has been very striking. Educational ideas have spread like wild-fire, and a new era has dawned upon civilization.

For the most part, these trade schools have been established by government for the education of the children of the laboring classes, and for the purpose of fostering particular industries.



Hence they have been as various as the trades and occupations of men, and may be classed under the general name of industrial schools. Special prominence has, of course, been given to what we have learned to consider national industries. Belgium had schools for weaving; France, for silks and laces; Switzerland, for watches and toys; Bohemia, for glass-making and pottery; and so on.

In North Germany and Austria, industrial schools have been more recently introduced; but they have been on a broader foundation, and with a more philosophical basis.

#### THE INSUFFICIENCY OF POLYTECHNIC SCHOOLS.

Austria had been foremost in the establishment of its higher polytechnic schools, hoping to solve the problems of practical education by the training of skillful engineers. But this plan failed to accomplish all that was expected. "Ten years ago," says Mr. F. Buisson, commissioner of education from France to Vienna and Philadelphia, "Austria resembled an army which had at its head a brilliant major-general, very mediocre corps and division officers, and no subordinate officers at all. Between the highest and the lowest industries, as between patron and workman, the tie of union failed. The trade and business of the country seemed manacled for the want of foremen. The gradual decrease of this middle class, the *elite* among workmen, indispensable as they are to commerce, agriculture, manufacturing, and all other kinds of industry, so stirred up public opinion, that the government, urged and seconded by numerous societies, undertook to establish at once a system of institutions for imparting instruction in trades and business to large classes of workmen and laborers, and their children." Austria has [in 1878] at least twenty-eight schools for weaving; three schools for lace; eight schools for the whole group of mechanical industries; a special school for watchmaking, at Vienna; fifteen schools for giving instruction in the arts of working wood, marble, and ivory; six for instruction in making toys; four for instruction in making baskets and mats; and seven for instruction in making arms, and in other metallurgical industries.

New industries have actually been introduced through the

agency of industrial schools, and a reasonable balance has been maintained between different trades. It will suffice now for me to give in detail the management and course of study in one or two of the best of European trade schools.

I select the .

#### ARTISAN'S SCHOOL OF ROTTERDAM

in the Netherlands, an institution that was fully represented at the Philadelphia Exposition. I am indebted to Superintendent J. P. Wickersham of Pennsylvania for this account, which appears in his report for 1876.

“The Artisan’s School at Rotterdam was established in 1869, and is intended for the sons of workmen. In order to gain admission they must be from twelve to fifteen years of age, and be able to read and write. An elementary knowledge of arithmetic is also required. The number of pupils is now about two hundred, and is increasing. They pay a small fee, and are expected to remain in the school for three years. The institution is both a school and a workshop. In the school are taught, for a part of the day, the branches in which instruction is usually given in our common schools, together with algebra, geometry, elementary mechanics and physics, drawing, singing, etc. The workshops, in which the remaining part of the day is spent, are arranged for different trades, and are large and comfortable. There are shops for each of the following classes of workmen: carpenters, blacksmiths, metal-workers, masons, stone-cutters, cabinet-makers, wood-carvers, metal-turners, and others less important. . . .

“The practical instruction . . . is given in the afternoon, in special workshops, by clever masters, where the boys are taught for carpenters, smiths, braziers, painters, masons, stone-cutters, cabinet-makers, wood-carvers, modelers, turners, etc. . . .

“It has been shown that boys who are occupied one half the day with books in the school, and the remaining half with tools in the shops, make about as rapid intellectual progress as those of equal ability who spend the whole day in study and recitation. And, in addition, the mechanical skill they acquire is of immense value.”

## THE APPRENTICE SCHOOL OF THE CITY OF PARIS

was opened in January, 1873. The school receives apprentices in iron and wood work. The course covers three years. Students must be not less than thirteen, nor more than sixteen years old. Instruction is free, and all tools, books, and materials are furnished. The entrance examination is in reading, writing, and elementary arithmetic. Students enter the school gate at seven o'clock A.M., and are dismissed at seven o'clock P.M. Each brings a morning and an afternoon lunch. The daily program, six days in each week, is as follows:—

From	7 A.M. to	8 A.M.	. . . . .	Study.
"	8 A.M. "	11 A.M.	. . . . .	Shop-work.
"	11 A.M. "	12 M.	. . . . .	Lunch and recreation.
"	12 M. "	2.30 P.M.	. . . . .	Shop-work.
"	2.30 P.M. "	3 P.M.	. . . . .	Lunch.
"	3 P.M. "	7 P.M.	. . . . .	Study and recitation.

The highest, or third-year, class has shop-work from eight till five o'clock, and but two hours of recitations daily.

The branches studied are: arithmetic, algebra, geometry, geometrical drawing, sketching and design, physics, chemistry, descriptive geometry, mechanics, history and geography, book-keeping, French, English, and common law.

The shop-work includes the details of some half dozen trades. The first year is spent in going the round of the trades for the purpose of finding the aptitudes of the pupils. At the beginning of the second year the apprentice, with the advice of his parents and teachers, decides upon a certain trade, to which he devotes himself exclusively for two years. Articles are made for the market, and skillful students are allowed from forty cents to one dollar for their work every fortnight. The school is popular, and its patronage is increasing.<sup>1</sup>

---

<sup>1</sup> I visited this school in 1885, and found it adhering closely to its original plan. Its director was clear, straightforward, and emphatic as to its scope and aim. The boys were to be mechanics, and each was to earn his living by his trade there learned. The school was full, and the government appropriations evidently generous and prompt. Tho differing widely from an American manual training school, this school and the more elementary one on Rue Turnefort, also in Paris,

I have been somewhat minute in presenting the details of these schools, in order that we might fairly consider the propriety of introducing similar

#### TRADE SCHOOLS IN THE UNITED STATES.

There are many who advocate this plan on a grand scale. A special committee of the Boston Social Science Association reported in January, 1877, a plan for, first, a "developing school, so established and arranged as to give all the pupils a good general idea of all the different trades, arts, or callings, in order that it may be ascertained, by themselves or the superintendent, for what kind of business they have the greatest natural genius." Secondly, a series of school-shops, in each of which a single trade should be taught.

The committee generously proposed to avoid the exceedingly narrow range of most actual workshops, by furnishing their school-shops with "every tool and appliance of every name and nature that is ever used in any shop whatever, so that the student would become acquainted with every manner of doing work, and the management of every kind of tool or device ever used in any place or business for doing work." Such, in brief, is the plan seriously urged upon the city of Boston to provide for the training of all the youth of the city. The recommendation closes with the cheerful prediction, that "the worth of the work made by the boys would probably pay current expenses after a very short time."

I do not wish to fail to appreciate the excellent spirit and main purpose of that report, but it seems to me that a little reflection will convince any one that their plan is thoroughly impracticable. Consider, only, the number of "trades, arts, or callings" in a single American city of half the size of St. Louis. Are not their names found under every letter of the alphabet,

---

has had great influence upon public education in that city. All, or nearly all, the free public elementary schools have a species of manual training in the shape of wood-work. I visited some of the best of these. The shop arrangements were generally crowded and crude. Moreover, tools were put into hands much younger than I could approve; but the teachers appeared to favor it, finding it wholesome, stimulating, and useful in many ways. The exercises were generally abstract.

and is not the list increasing every year? As, for example, bakers, bankers, barbers, basket-makers, blacksmiths, book-binders, brewers, brick-layers, brick-makers, brush-makers, butchers; and, again, machinists, masons, millers, mill-wrights, miners, molders, musicians, etc.<sup>1</sup> It is obvious that all such occupations must be included, or else they would soon disappear from society, — all the youth being directed into other paths.

Now, have the committee ever sat down to a serious estimate of the cost of all the trade shops, with their unequaled and complete equipment of tools and appliances? I think not. It is perfectly safe to say that their cost would far surpass the cost of all the schoolhouses and churches in the city.

But it avails little to show the absurdity of a proposition too extravagant to be generally indorsed. The question still remains, Will trade schools flourish on American soil? Would a school like the Artisan's School of Rotterdam, or the Apprentices School of Paris, thrive in St. Louis? I honestly think it would, to the extent of a single school; but I think it much less in harmony with the free spirit of our social organization than the plan of manual education I am about to propose, and I can not recommend it as a feature of our system of public education.

America has not yet adopted that sort of industrial education, and I doubt if she ever will: she will do better.

#### TRADES NOT TO BE TAUGHT AT SCHOOL.

The first reason why I think we shall not wisely attempt to teach the details of actual trades is, that the scope of a trade is far too narrow for general educational purposes. Our physical education must be as broad and liberal as our intellectual.

There is no breadth of manual training in being a tailor, or a painter, or a molder, or a shoemaker; and he who learns either trade is rarely able to get out of the rut. Such being the case, both parents and children often hesitate to choose a trade, when the choice seems to be for life. In European society the feeling

---

<sup>1</sup> "The trades are many, the arts are few." — PROF. JOHN D. RUNKLE.

is very different. The son of a miner goes to the mines as a matter of course, and the son of a weaver has generally no hopes beyond the loom. Whatever ambitious dreams a fond parent may cherish, or whatever visions may quicken the pulse of the humble child of a European laborer, they are smothered and crushed under the ruthless wheels of an inexorable destiny. In America, on the contrary, there is no limit to the possible social advance of the poor man's child. A nation which bestows its highest honors on a flat-boat man and a rail-splitter of the prairie, and associates with him a man who never went to school, and whose only teacher was his wife, can not expect its sons to fetter themselves by a trade which threatens to tie them down to a life of toil and obscurity.

To the man of only ordinary enterprise and force, the shackles of a trade early learned and closely followed for a few years may become as strong as steel, and, like the fetters of a slave, bind him to an occupation he would flee, but can not. We have all seen men who could do one thing and nothing else, — not even if their lives depended on it. Their special education had been begun too early, and limited to the absolute needs of the trade. Do not misunderstand me. I am in favor of having nearly every young man learn a trade, or rather the essential elements of many trades; but I would not have him learn a single specialty so early and so exclusively as to learn nothing else. The objection to a self-supporting trade school has additional force when we remember that the standard in a trade is determined by the local demand for the products of that trade. A shop which manufactures for the market, and expects a revenue from the sale of its products, is necessarily confined to salable work; and a systematic and progressive series of lessons is impossible. If the object of the shop is education, a student should be allowed to discontinue any task or process the moment he has learned to do it well. If the shop is to make money, the students will be kept at work on what they can do best, at the expense of breadth and versatility.

Prof. Francis W. Newman of England said in 1872: "To cultivate the eye and hand, in and by the use of various tools,

is of endless industrial value. Some one has yet to develop a systematic teaching of what may be called carpenter's drawing. The more various the cultivation of the hand and the eye, the more efficient will be the laborer in any special work. Definite trades can not be taught in a national school system; but the faculties may be trained which will be serviceable in all trades."

It is claimed that students take more interest in working upon something, which, when finished, has intrinsic value, than they do in abstract exercises. This is quite possible, and proper use should be made of this fact, — just as it is well to stimulate the interest of a child studying arithmetic, by reckoning up the cost of the daily supply of meat and vegetables, or by computing the cost of material and labor put into a dress; but, if all education were limited to such practical examples, our schools would be useless. The idea of a school is, that children are to be graded and taught in classes; the result aimed at being, not at all the objective product or finished work, but the intellectual and physical growth which comes from the exercise. Of what use is the elaborate solution in algebra, the minute drawing, or the faithful translation, after it is well done? Do you not erase the one, and burn the other, with the clear conviction that the only thing of value was the discipline, and that that is indestructible?

Now, should we not proceed in manual education on precisely the same plan? *Should we not abstract all the mechanical processes and manual arts and typical tools of the trades and occupations of men, and arrange a systematic course of instruction in the same, and then incorporate it into our system of education?* Thus, without teaching any one trade, we teach the essential mechanical principles of all. The thousands of tools used in the arts are but modifications of a few simple elements. They differ in degree more than in kind, and in the extent to which different kinds of tools are incorporated into the same complex machine. The universal tools are scarcely more than a half dozen in number.

I am aware that some will think that I aim at a sort of "jack-of-all-trades, but master of none." I will only remark that a good jack-of-all-trades may easily become master of any.

Some of you will recall the glowing admiration with which Theodore Winthrop, the brilliant and ill-fated young writer of the New York Seventh Regiment, spoke of the skill and handicraft of the Eighth Massachusetts Regiment. The two regiments went together to the early defense of Washington, in April, 1861. The Yankees had captured a ferry-boat near Baltimore, manned the engines, and steamed to Annapolis, saving it and "Old Ironsides" from capture. They found the railroad track leading to Washington torn up.

"'Wanted, experienced track-layers!' was the word along the file. All at once the line of the road became densely populated with experienced track-layers fresh from Massachusetts.

"Presto, change! The rails were relaid, spiked, and the roadway leveled and better ballasted than any road I ever saw south of Mason and Dixon's line. 'We must leave a good job for these folks to model after,' says the Massachusetts Eighth.

"A track without a train is as useless as a gun without a man. Train and engine must be had. 'Uncle Sam's mails and troops can not be stopped another minute,' our energetic friends conclude. So . . . in marches Massachusetts to the station. 'We, the people of the United States, want rolling-stock for the use of the Union,' they said, — or words to that effect.

"The engine — a frowsy machine, at the best — had been purposely disabled.

"Here appeared the *deus ex machina*, Charles Homans, Beverly Light Guard, Company E, Eighth Massachusetts Regiment.

"That is the man, name and titles in full, and he deserves well of his country.

"He took a quiet squint at the engine, — it was helpless as a boned turkey, — and he found 'Charles Homans, his mark,' written all over it.

"The old rattletrap was an old friend. Charles Homans had had a share in building it. The machine and the man said, 'How d'ye do?' at once. Homans called for a gang of engine-builders. Of course they swarmed out of the ranks. They passed their hands over the locomotive a few times, and presently it was ready to whistle and wheeze, and rumble and gallop, as if no traitor had ever tried to steal the go and the music out of it. . . .

"We of the New York Seventh afterwards concluded that whatever was needed in the way of skill or handicraft could be found among those brother Yankees. They were the men to make armies of. They could tailor for themselves, shoe themselves, do their own blacksmithing, gunsmithing, and all other work that calls for sturdy arms and nimble fingers. In fact, I have such profound confidence in the universal accomplishment of the Massachusetts Eighth that I have no doubt if the order were, 'Poets to the



front!' 'Painters, present arms!' 'Sculptors, charge bayonets!' a baker's dozen out of every company would respond." (*Atlantic Monthly*, vol. vii., pp. 747, 750.)

When Winthrop said, "Such are the men to make armies of," he might have added, *Such are the men to do any thing with*, — to span mighty rivers, to subdue the wilderness on mountain and plain, to cultivate literature, science, and art; in short, to spread the blessings of civilization.

#### THE RUSSIAN METHOD.

To Russia belongs the honor of having solved the problem of tool-instruction. Others had admitted that practice in using tools and in testing materials should go hand in hand with theory; but Russia first conceived and tested the idea of analyzing tool practice into its elements, and teaching the elements abstractly to a class. In their hands, manual tool-education has become a science. While recognizing the lead of Russia, it is necessary to recognize, next, the very valuable contributions to progress in this direction made by the Massachusetts Institute of Technology, under the guidance and inspiration of Prest. John D. Runkle. His very able reports give in full the history of the growth and working of their School of Mechanic Arts, and demonstrate fully the general practicability of the method employed.

"The Imperial Technical School of Moscow was the first to show that it is best to teach an art before attempting to apply it; that the mechanic arts can be taught to classes through a graded series of examples [or exercises], by the usual laboratory methods which we employ in teaching the sciences. Making the art — and not the trade — fundamental, and then teaching the art by purely educational methods, is the Russian system. The system is instruction in the arts for the purpose of construction, and not construction for the purpose of instruction."

Here is the point where the best manual training schools differ radically from the ordinary system of apprenticeship. In the latter the learner acquires the "arts" involved in a piece

of work incidentally, and generally without a conscious analysis; in the former, the "arts" are made the direct object of his study and attention. Their subsequent combination (which may or may not follow in his school experience) is a very simple matter.

Mr. Runkle illustrates this point as follows: "Every one is well aware that the successful study of any art — free-hand and linear drawing, or music instrumental or vocal, or painting — is only attainable when the first steps are strictly subject to the laws of gradation and succession; when the student adheres to a definite method, thus surmounting, little by little, and by certain degrees, the difficulties to be encountered. All the arts just named possess a method of study which has been well worked out and defined, since they have long constituted a part of the education of the well-instructed classes. They have, therefore, become subject to scientific analysis and objects of investigation, with the view of defining those conditions which should render the study of them as easy and well regulated as possible."

Let us, now, see how this idea will apply to tool-work upon metals or wood. Every manufactured article, whether it be a machine, or a piece of furniture, or a bridge, consists of a combination of a small number of typical forms or shapes more or less modified. Take, for instance, a piece of furniture. The joints are of the simplest character, — a plain mortise and tenon, or bored holes and cylindrical pins, all glued. The surfaces are either plane or regularly curved. The most difficult point is accuracy in the angles, which is gained by using the try-square and working to fine lines. If the furniture is carved, you will find on analysis that that work is the result of a very few elements variously repeated and combined.

It is just so of a watch or a steam-engine, so far as essential shapes of the different parts, both in the fixed frame-work and in the moving members, are concerned; they are very few in *kind*, the apparent variety consisting mainly in the size of the pieces. Now, is it not the most reasonable thing in the world to teach these mechanical elements separately, abstracted from the machines into whose construction they enter? When the

young apprentice has been through with the alphabet of mechanical elements, so that in each case he knows what tools to use, and is able to execute the work with precision, you may be sure he is able to construct a machine from a given design, altho he never has done so. When you learned to write (to illustrate this point still further), you began with straight lines, then single curves and hooks, then double curves and ovals. These are the elements of penmanship. You next learned how to combine these elements to form the twenty-six letters of our alphabet. When you had learned to combine these letters into words, you had mastered the art of penmanship, even if you had never written a sentence. Outside the three lessons I have mentioned, there is absolutely nothing to be learned. You may gain facility and improve constantly in the execution of these steps, but nothing more. On the other hand, I have seen persons who could write their names, but nothing else. They had committed to memory, with much patient labor, the complicated scrawls which they had been told represented their names; and the utter lack of discrimination with which they reproduced them showed that they knew nothing of the significance of particular lines and flourishes. These persons typify the extreme utilitarian wing of educators, who would teach nothing not directly productive of useful work. Why should such ever write "Evil communications corrupt good manners," when they are likely to be called upon for nothing beyond signing their names? My illustration fairly shows the difference between an art and a mere trade.

Having reached a philosophical method of manual education, our next step is to arrange the elements into groups, and grade them in the groups according to the materials to be wrought upon, and the tools to be used.

It is hardly necessary to add that parallel and simultaneously with the above runs a corresponding course of free-hand and mechanical drawing, the first and most important element of manual education.

Much thought has been given to working out and properly grading the elements under each of these groups. Prest. Runkle's paper in the Forty-first Annual Report of the Massa-

chusetts Board of Education gives complete their courses in vise-work and forging. The details of the other groups have not yet been fully worked out.

The first course in vise-work consists of twenty-two designs or examples in filing, chipping, and sawing steel, cast and wrought iron, to be worked out separately by each student. The time allowed for the work is thirty lessons of four hours each, or one hundred and twenty hours in all. Although this is equal to only twelve days of ten hours each, the work of the students is pronounced by a committee from the State of Rhode Island to be superior to that of the ordinary apprentice of two years' standing.

I can not venture upon more than a very brief analysis of this work as done by a single student, and kindly sent us by Prest. Runkle. Each piece was executed with the most suitable hand-tools, and the work is so graded that in turn all the tools are used. Each exercise has a new feature, but depends, to a certain extent, upon what has gone before. Each piece is stamped with a number indicating the degree of excellence in the workmanship. The class is told beforehand just what the points to be aimed at are; and the relative importance of different points, in the critical estimate of the work by the instructor, is definitely shown. This clear analysis of all the points in an exercise makes each workman a good judge of workmanship. The careful analysis of each piece of filing given by Mr. Walberg, the designer of the exercise, accompanied by the heliotype-print illustrations, constitutes a very valuable contribution to educational literature.

#### AN EXERCISE IN FILING.

Take, for example, No. 4. The blank furnished each member of the class consists of a flat piece of cast-iron planed on two opposite faces, with a round hole through it. The tools furnished are six files (each for a special purpose), and two try-squares, — one, four and one-half inch; the other, one and one-half inch. The instructor says to his class, who are arranged in the filing and chipping shop, each with his complement of tools, —

“ This piece is to be made square and true around the edges ;

and the round hole is to be made a square one, according to the lines I have marked on each plate. It is designed to teach the use of two new kinds of files, in addition to extending the use of those you have already had, and at the same time to show you how to get the outside edges square with each other without the aid of lines, using lines only where the new files are needed. One side or face of the piece is to be draw-filed (or smoothed) in finishing it, thus removing the lines marking the boundary of the square hole, provided the hole is finished accurately to the line, so that its removal will not destroy the evidence of careless work.

“Twenty-five per cent will be allowed for filing the square hole accurately to the line on each face.

“Fifteen per cent will be allowed for good corners on the inside. You will test your pieces with the small try-square. This point involves true plane faces to the holes.

“Ten per cent will be allowed for making an outside edge square with an adjacent edge.

“Twenty per cent for making all four edges square with each other.

“Ten per cent for careful removal of all cross-marks.

“Ten per cent for edges straight lengthwise.

“Ten per cent for edges straight crosswise.

“Total, one hundred per cent. The time allowed for this work is four hours. Begin with the square hole. Secure the blank in the vise, and use first the six-inch pillar bastard file.”

The instructor then explains the features of the new tools, and the method of using them. He also reminds them of their former exercises, and shows how they enter into the present one. All students then go on with their work for four hours, or until the task is done; the instructor giving such individual assistance as may be necessary. The instructor in filing and chipping found it possible to teach a class of thirty-two boys, whose ages ranged from fifteen years upwards.

I have pictured a single exercise; and, with obvious changes, you can picture all. The same principle runs through the use of all kinds of tools and materials. This is the Russian method

in practice. The visible results serve only to illustrate the training, unless it be to use them as blanks for another exercise.

Do you think young men would be interested in such work? As a matter of fact, they are much interested. Every exercise has something new in it. A new surface is to be formed, or a new feature of some sort is to be added, and the interest is fresh. The Rhode Island committee already referred to report that they "found a class of thirty-two boys at work on a chipping exercise, with hammer and chisel, under the instruction and constant supervision of an expert mechanic, employed as teacher of practical mechanics; and it was easy to perceive that the class instruction in this branch of education was as systematic and simple as the teaching of a class in arithmetic or grammar in one of our best public schools."

An exceedingly interesting and instructive experiment of the Russian method of tool-instruction was made in Boston, Mass., during the past two winters, by the

#### INDUSTRIAL SCHOOL ASSOCIATION.

The Association had discussed the importance and the feasibility of making manual education a part of public instruction. The first winter, they organized an evening class of thirty-two boys in wood-carving. Their ages ranged from twelve to sixteen. About half of them were still attending the day-school, the others were employed in stores and offices. A course of twenty-four lessons in wood-carving was prepared with special reference to securing the greatest amount of instruction with the least expenditure of material. It was not designed to make finished workmen, but to take advantage of the natural inclination towards handicraft. The tools used were three in number, — the flat chisel, the gouge, and a veining-tool. Blocks of white wood six inches long, three inches wide, and one and one-half inches thick were the material worked upon. Each boy had his place at a work-bench four feet long by two and one-half feet in width. Each had a vise with wooden jaws and an iron screw; a drawer with lock and key, in which the tools were kept; and a gas-burner with a movable arm. The report of the committee in charge gives heliotypes of the various finished

blocks. Mr. Chaney says, "It will be noticed that no specific article was made in the school. The variety of manipulations and change of patterns were enough to maintain the freshness of the scholars' interest, without introducing the manufacture of any articles of trade or commerce. The object of the school was, not to educate cabinet-makers, or artisans of any special name, but to give the boys an acquaintance with certain manipulations which would be equally useful in many different trades. '*Instruction*, not *construction*, was the purpose of the school.' "

The success of this experiment led the committee to express the belief that it would be easy to establish, in connection with all the public grammar schools (corresponding to what are called in this city branch high schools), an annex for elementary instruction in the use of the half-dozen universal tools; i.e., the hammer, saw, plane, chisel, file, and square. "Three or four hours a week, for one year only of the grammar-school course, would be enough to give the boys that intimacy with tools, and that encouragement to the inborn inclination to handicraft, and that guidance to its use, for want of which so many young men now drift into overcrowded and uncongenial occupations, or lapse into idleness or vice."

Encouraged by the success of the first experiment, the Association decided to adopt for their second experiment a course of instruction in the use of the common wood-working hand-tools. As I have said, the Russian system involves class instruction; the individual needs nothing, unless it be repetition and caution. The Association believed that the general instruction could be given best by a carefully printed text, precisely setting forth every detail essential to the best performance of each manipulation. They also determined that in the preparation of this text every thing that forethought, study, and experience could do should be done. They therefore employed the best service which they could command in the preparation and critical revision of a series of primary lessons in the use of wood-working hand-tools, to be followed by a similar series of more advanced lessons in applications of these tools to the production of typical forms in carpentry and joinery.

The first eleven lessons are as follows:—

1. Use of the cross-cut saw, sawing to line.
2. Use of the hammer, striking square blows.
3. Use of the splitting-saw, sawing to line.
4. Use of the jack-plane, smoothing rough surfaces.
5. Use of the hammer, driving nails vertically.
6. Use of the splitting-saw, sawing at exact angles to upper surface.
7. Use of the jack-plane, setting the plane-iron.
8. Use of the hammer, driving nails horizontally.
9. Use of the bit and brace, boring in exact positions.
10. Use of the mallet and chisel, mortising.
11. Use of the jack-plane, producing surfaces which intersect at exact angles.

Auxiliary drawing exercises in laying out the work by measuring and lining are incidental to all the lessons.

#### MANUAL TRAINING IN THE POLYTECHNIC SCHOOL OF WASHINGTON UNIVERSITY.

I have given full accounts of the educational experience of Boston, for the reason that it has really taken the lead, so far as this country is concerned, in working out the problem of manual education, and because there has lacked neither the money nor the students necessary to give the method the fullest possible test; and yet I could have quoted our own experience, and made a fair showing. St. Louis is not without interest in this matter; and we have not failed to find those who were both able and willing to make it possible for us to break ground, as it were, in this new field of labor and study. Full twenty years ago some half-score of the noble men of this city were filled with the idea of establishing here a polytechnic school, which should be truly and literally such. In their generous plan the many arts were not only to be scientifically expounded by able professors, but they were to be illustrated by practical machines and expert workmen. I do but simple justice to Col. John O'Fallon, John How, Gerard B. Allen, Ralph Sellev, James B. Eads, Giles F. Filley, and others whom I am unable to name, when I say, that, in contributing to the means where-



with to erect that magnificent polytechnic building on the corner of Chestnut and Seventh Streets, it was their ambition to do just what we find it possible to do now with less than one-tenth the money. Undertaken with the highest motives, but with no clearly defined plan, the enterprise was virtually a failure. The building was begun before the war; at different times the work was suspended, and then renewed at enormous cost. Nine long years were consumed ere the building was finished, and then it was found totally unsuited to the use intended. These plain words are not said in criticism; for the noble aims and devotion of John How, and the generous hand of Col. O'Fallon, call only for a tribute of gratitude. They and their co-laborers were struggling to realize an idea which it is our privilege to-day to carry to successful issue.

For the last five years we have had a fair workshop, in which the students of this polytechnic school have worked to a certain extent; but only during the present year have we been able to work with much system. With the aid of our staunch friend Mr. Gottlieb Conzelman, we fitted up during last summer a wood-working shop with work-benches and vises for eighteen students; a second shop for vise-work upon metals, and for machine-work; and a third, with a single outfit of blacksmith's tools. During the last few months systematic instruction has been given to different classes in all these shops. Special attention has been paid to the use of wood-working hand-tools, to wood-turning, and to filing. The age of the students has ranged from fifteen to about twenty-two. None of the students have had much experience, and of course you can not expect nicely finished work. The specimens are not shown on account of the excellence of the workmanship, but because they illustrate our method.

The amount of time given to shop-work has generally been only four hours per week, — two lessons of two hours each. The junior class in mechanical engineering gave eight hours. Shop-work has been done in the afternoon, and there has been no less work required in the morning recitations than formerly. The four hours per week, which is equivalent to two days per month, seems too small an allowance to be of much practi-

cal value, four years would, on the present plan, suffice to give an excellent idea of the uses of all our tools, the properties of materials, and considerable manual skill. I have yet to hear from the parent who does not approve of our plan of shop-work. Our running expenses in the shop are now about a hundred dollars per month; but we could, without perceptible increase of cost, double our present number of students. No extra fee has been charged on account of shop-work; but, without permanent endowment, this arrangement could not long continue. The experience of this year has been invaluable to us; and we are now clear in our conviction that a series of commodious instruction-shops, well furnished with machinery and tools, and so liberally endowed as to require only a nominal fee from students, would be of inestimable value to the youth of this city.

It is well understood that many students can not wisely undertake the full course of intellectual study we have laid down for regular classes. A decided aptitude for handicraft is not unfrequently coupled with a strong aversion to, and unfitness for, abstract and theoretical investigations. There can be no doubt that in such cases more time should be spent in the shop, and less in the lecture and recitation room. The adoption of this principle would soon lead to the formation of a class in what might be called the "Mechanical Course," whose students should work in the shop daily two or three hours, following at the same time a somewhat abridged course of study.

It is time for me to close. Much could be said in regard to the extension of manual education to all the grades of our schools, from the lowest to the highest; but I must be brief. The manual education, which begins in the kindergarten, before the children are able to read a word, should never cease. The physical powers of a child develop first, and their cultivation should at least keep pace with the growth and development of his mental faculties. Just how we shall supply the missing links in the chain which joins the kindergarten with the fully equipped shops of the polytechnic school, we can not with certainty suggest. The problem is an open one, and thousands of earnest and intelligent educators are devoting them-

selves to its solution. I trust that St. Louis will in this, as in many other educational matters, contribute largely. At present we have drawing and penmanship, both of which are essentially manual. To this I would add, tinting with a brush, mixing colors, weaving and braiding, molding of tiles and the making of mosaics, models of geometrical and natural forms. Girls should be taught needle-craft, and, in the higher grades, the elements of cooking.

Suppose a visitor from another planet were to visit us in our homes and in our places of business. Suppose he looked into the whole economy of our domestic and social lives, and then was requested to map out the best course of instruction for both girls and boys. Do you think he would fail to put early on the list for girls the proper preparation of food for the table? Do we not say *food, clothing, and shelter* are the three essentials of physical existence? Then, let *food* come boldly into our program. Let systematic instruction be given in the all-important art of cooking. And would not our visitor insist that our boys should be taught to supplement their feeble strength by the all-powerful tools with which we subdue all the kingdoms of nature? At ten years, give boys knives, and gouges, and hammers, and saws, and squares. Let them carve in soft wood and plaster, and learn to strike true and square blows. Carlyle says the choicest present you can make a child is a tool. "Be it knife or gun, for construction or destruction; either way it is for work, for change." At twelve they are ready to use the plane, the chisel, and the whole chest of tools.

Until you reach machine-tools, the shop outfit may be of the simplest character. Benches, vises, and a half dozen tools for each student in a class are all that you need; the whole cost would hardly exceed that of the furniture in an ordinary school-room.

Three classes of say twenty-five each, or seventy-five boys, could be taught a two-hour lesson in the same room in a day. If each boy had but two lessons per week, three times that number of boys could be accommodated on different days, or two hundred and twenty-five in all. It thus appears that one

room, properly fitted up, would be enough for either the academy of this university or either of the city high schools. A competent teacher, at say one thousand dollars, in such a room, would, I think, be as valuable to the interests of education as any in the whole corps. Such annexes I commend strongly to school boards.

The more fully furnished shops, containing the whole list of forges, engines, and machine-tools, must of course be left to private institutions founded by such men as Stevens, Hopkins, Cornell, and those whose names I have mentioned to-night.<sup>1</sup>

---

<sup>1</sup> It must be remembered that this address was given in 1878 before the present Manual Training School was established. Its direct influence was soon plainly seen. Mr. Samuel Cupples, after carefully reading a printed copy, proposed that the experiment be tried. The result was the speedy organization of the Manual Training School, as related on page 7.

## CHAPTER XII.

EXTRACTS FROM THE PROSPECTUS PUBLISHED IN  
NOVEMBER, 1879.<sup>1</sup>

## THE ORIGIN AND PURPOSE OF THE SCHOOL.

THE Manual Training School owes its existence to the conviction, on the part of its founders, that the interests of St. Louis demand for young men a system of education which shall fit them for the actual duties of life, in a more direct and positive manner than is done in the ordinary American school.

St. Louis already has large manufacturing as well as commercial interests, and we all expect to see these interests greatly increase. We see in the future an increasing demand for thoroughly trained men to take positions in manufacturing establishments as superintendents, as foremen, and as skilled workmen. The youth of to-day are to be the men of the next generation. It is important that we keep their probable life-work in view in providing for their education. Excellent as are our established schools, both public and private, it must be admitted that they still leave something to be desired; they do not, and probably they can not, cover the whole ground.

This conviction of the incompleteness of present means and methods of education has found utterance in many ways. Some of the best friends of education have expressed themselves in strong and suggestive language. All such agree in the conclusion that the main deficiency is in the direction of manual education.

---

<sup>1</sup> These extracts are given partly to show the clearly defined position of the school at its start. That position has been abundantly strengthened by experience, and we have been enabled to make a much fuller statement in Chap. IX. and elsewhere.

Hence, as has so often been said, nearly all our skilled workmen are imported. Our best machinists, miners, weavers, watch-makers, iron-workers, draughtsmen, and artisans of every description, come from abroad; and this is not because our native-born are deficient in natural tact or ability, nor because they are in point of fact above and beyond such occupations, but because they are without suitable means and opportunities for getting the proper training.

About two years ago the Legislature of the State of New Jersey appointed a commission to investigate and report on the course the State ought to take in the interest of the higher order of manufactures. The commission consisted of Messrs. Samuel E. Brown, Thomas N. Dale, and Prof. Robert H. Thurston, who acted as secretary and compiled the report. In their report of 1878, the commission strongly advocated the establishment of trade schools (i.e., manual training schools) in which should be practically taught the essential principles which underlie the industries. By such a course alone, they argue, can we, as a manufacturing people, hope to compete successfully with the workmen and manufacturers of Europe.

The arguments of the commission apply as forcibly in St. Louis as in New Jersey.

There is, doubtless, much to be learned in the organization and administration of a manual training school on American soil; but its value to a manufacturing community has been demonstrated beyond question, and its essential features have been clearly determined.

*It is believed that, to all students, without regard to plans for the future, the value of the training which can be got in shop-work, spending only from four to twelve hours per week, is abundantly sufficient to justify the expense of materials, tools, and expert teachers.*

. . . . .

One great object of the school will be to foster a higher appreciation of the value and dignity of intelligent labor, and the worth and respectability of laboring men. A boy who sees nothing in manual labor but mere brute force despises both the labor and laborer. With the acquisition of skill in him-

self, come the ability and the willingness to recognize skill in his fellows. When once he appreciates skill in handicraft, he regards the workman with sympathy and respect.

In a manual training school, tool-work can never descend into drudgery. The tasks are not long, nor are they unnecessarily repeated. In this school, whatever may be the social standing or importance of the fathers, the sons will go together to the same work, and be tested physically as well as intellectually by the same standards. The result in the past has been, and in the future it will continue to be, a truer estimate of laboring and manufacturing people, and a sounder judgment on all social problems. If the manual training school should do nothing else, it would still justify all the efforts in its behalf if it helps in the solution of the difficulties between labor and capital.

In these ways it is hoped that the Manual Training School will serve the interests of the people of St. Louis. The attention of parents and educators is respectfully called to the curriculum of study and shop-practice given below, and all are earnestly invited to consider how far this school meets their individual wants.

#### COURSE OF STUDY.<sup>1</sup>

The experience of several years in our own workshops,<sup>2</sup> the experience of many somewhat similar schools in this country and in Europe, and a careful consideration of the interests of St. Louis, enable us to sketch out with confidence the proper curriculum of work and study for our pupils.

As stated in the ordinance, the course of instruction will cover three years; and the school-time of the pupils will be about equally divided between mental and manual exercises. Neither intellectual nor physical labor will be carried to the extent of weariness.

The change from recitation to the shop, and from shop to study and recitation, will be agreeable and healthful, keeping both mind and body fresh and vigorous.

In mathematics the course of instruction will be thorough, but not extended. Arithmetic, algebra, geometry, and plane

---

<sup>1</sup> For the present course of study, see Appendix I.

<sup>2</sup> See Chapter I.

trigonometry will be studied in succession. The application of these branches will be made in bookkeeping, mechanical drawing, physics, and mechanics.

Some attention will be given to physical geography, and the principles of chemistry.

The English language and literature will be carefully studied throughout the course. Every graduate of the school will have a fair command of the English language, whether in writing or speaking.

History, practical ethics, and political economy will each find a place on the program,—the treatment of each subject being adapted to the capacity of the class.

Special attention will be paid to drawing during the whole course. Drawing is the short-hand language of modern science. Careful drawings are to technically educated people what pictures are to children. They show at a glance what it is not in the power of words to express. It is a universal language, and should be read and understood by all men.

#### MANUAL EDUCATION.

Thus far our course of study is familiar. We come now to the manual training proper — to that feature which is to distinguish this school from those around it. How shall we train the hand to keep pace with the eye and the mind, and to fit it well for its future uses?

During the last hundred years the world has made rapid strides in the invention and use of tools. We do nothing with the unaided hand; everything is done by tools.

Tool-instruction, then, is what is wanted,—instruction in the nature, theory, and use of tools. Thus shall we place within reach the key which is to unlock the mysteries of our busy shops and factories.

But which are the tools whose use we are to teach? Before answering this question, it is to be observed that the apparently great variety in tools and mechanical processes arises from different combinations of very simple elements. The number of hand-tools is small; one can easily count them on his fingers. They are the *ax*, the *saw*, the *plane*, the *hammer*, the *square*, the



*chisel*, and the *file*. The study of a tool involves an examination of its form, and the theory of its action, as well as its actual use at the bench or forge. After the hand tools our pupils must become familiar with the typical machine tools which are chiefly employed in mechanical pursuits. A knowledge of materials and processes is as important as an acquaintance with tools.

#### POLICY OF THE SHOP: NO ARTICLES MADE FOR SALE.

Throughout the course of shop-work, in addition to the abstract exercises, which are designed to give certain practices and illustrate certain processes, actual tools or part of tools needed, either in the shop or in the laboratories of the university, will from time to time be made, as the classes become fitted for such practical work. Aside from these, however, the products of the shops are not intended to have any commercial value; in other words, the shops will not manufacture for the market. Whatever may be the advantages of making things which are to be subject to the tests of trade, we think that in this case the objections outweigh them.

In the first place, the management of this school does not propose that its shops shall enter into competition with manufacturing establishments. Proprietors of machine-shops and factories need not look upon this institution as a rival.

In the next place, the scope of a single trade is too narrow for educational purposes. Our manual education should be as broad and liberal as our intellectual. A shop which manufactures for the market, and expects a revenue from the sale of its products, is necessarily confined to salable work, and a systematic and progressive series of lessons is impossible. If the object of the shop is education, a student should be allowed to discontinue any task or process the moment he has learned to do it well. If the shop were intended to make money, the students would be kept at work on what they could do best, at the expense of breadth and versatility.

It is claimed that students take more interest in working upon something, which, when finished, has intrinsic value, than they do in abstract exercises. This is quite possible, and proper use should be made of this fact; but, if all education were limited

to such practical examples, our schools would be useless. The idea of a school is that pupils are to be graded and taught in classes; the result aimed at being, not at all the objective product or finished work, but the intellectual and physical growth which comes from the exercise. Of what use is the elaborate solution in algebra, the minute drawing, or the faithful translation after it is well done? Do we not erase the one, and burn the other, with the clear conviction that the only thing of value was the discipline, and that that is indestructible?

Now, we proceed in manual education on precisely the same plan. We abstract all the mechanical processes and manual arts and typical tools of the trades and occupations of men, arrange a systematic course of instruction in the same, and then incorporate it into our system of education. Thus, without teaching any one trade, we teach the essential mechanical principles of all.

#### MANUAL TRAINING SCHOOLS COMPARED WITH ORDINARY SHOPS.

These two paragraphs are from the New Jersey report referred to on page 290:—

“ Experience has shown these systematically and intelligently conducted schools to be far more efficient means of education and training for the workmen than even the best managed mill. The impossibility of giving methodical instruction in all matters of detail, or of accommodating the time and the movements of the instructor to the capacity and progress of the learner; the jealousy and the unaccommodating spirit of overseers and managers, and the utter impossibility of permitting the financial results of commercial work to be affected by the interests or the blunders of the novice, combine to preclude, absolutely, all effective tuition in the mill.

“ Again, the mill is the more successful, commercially, as it confines itself the more strictly to a particular grade or a special class of goods, for the production of which it is best fitted, and as it confines the operatives, each to a certain department, and to a single and never-changed kind of work; it is thus impossible to reconcile the interests of the learner, who must

seek a knowledge of all departments, and of every operation, with those of the mill-owner who is most prosperous when each individual is confined to the task for which he or she is best fitted."

This extract is inserted for the purpose of meeting the objection, which has been often made, that, after all, the shop of the manufacturer is the best place for a young man to learn the use of tools. Abundant testimony proves that the objection is not sound. In the shop of a manufacturer, one readily learns the details of the business. But in an instruction-shop, where the only duty of the expert teacher is *to teach*, the pupil learns to be a good workman much quicker than in an ordinary shop; and not only does he make more rapid progress in the right direction, but he is saved from falling into clumsy habits and methods of work. Too often is the ordinary apprentice left to find out the right way by personal hard experience, as though he could not profit by the experience of others.

The practical value of school-shop instruction has been shown in countless instances. Thousands and thousands of the skilled workmen, engineers, foremen, and manufacturers, now in France and Germany, got their tool-education and their intellectual training simultaneously in a school.

Almost without exception the graduates of the school of "Arts and Trades," and the "Apprentice School," both in the city of Paris, readily find and fill positions as skilled workmen, from which, as soon as they have learned the special requirements of a particular trade or occupation, they rapidly rise to places of trust and responsibility. The ordinary shop-trained workman is not a draughtsman, has little knowledge of either mathematics or physics, and no skill or finish at either writing or speaking. Only those endowed with remarkable intellectual power rise above the plane of a good mechanic.

Prof. Thompson, the principal of the Worcester Free Industrial Institute (a school admirably equipped with shop and tool facilities), says that it is confidently expected that "the graduates in the department of mechanics will be as skillful mechanics as ordinary apprentices who have served three years in a shop, in addition to the advantages of a solid education." This expectation seems to be well founded. An examination

of the record of 1878 shows that out of their seventy-four graduates in the department of mechanics, at least fifty-three per cent were either engaged in manual labor, or they had, through their superior training, won positions where they were directing the labor of others.

So far as we can judge from the brief experience of the workshops of Washington University, shop-work, when properly managed, results in the acquisition in a very short time of a high degree of skill, and the establishment of a permanent liking for mechanical pursuits.

Whatever may be the final occupation of individual cases, we may be sure that the legitimate result of this school will be that an increased number of young men will be led into mechanical pursuits, and that many of them will look back to this school as the institution which helped them to be *both* "*willing and able to work.*"

## CHAPTER XIII.

## THE PROVINCE OF PUBLIC EDUCATION.

DR. SAMUEL JOHNSON considered education as needful to the "embellishments of life." In his day very few were educated at all, and those few for society or public service. The toiling masses had no education, were supposed to need no education, and, while discussing details, educators and scholars took no thought of what we call the common people.

Said Johnson (in his "Life of Milton") :—

"The truth is, that the knowledge of external nature, and the sciences which that knowledge requires or includes, are not the great or the frequent business of the human mind. Whether we provide for action or conversation, whether we wish to be useful or pleasing, the first requisite is the religious and moral knowledge of right and wrong ; the next is an acquaintance with the history of mankind, and with those examples which may be said to embody truth, and prove by events the reasonableness of opinions. Prudence and justice are virtues and excellences of all times and of all places. We are perpetually moralists, but we are geometricians only by chance. Our intercourse with intellectual nature is necessary; our speculations upon matter are voluntary and at leisure. Physiological learning [by which he means a knowledge of the laws and phenomena of the external world] is of such rare emergence, that one may know another half his life without being able to estimate his skill in hydrostatics or astronomy; but his moral and prudential character immediately appears.

"Those authors, therefore, are to be read at schools that supply most axioms of prudence, most principles of moral truth, and most materials for conversation; and those purposes are best served by poets, orators, and historians."

This statement was, no doubt, entirely adequate to the demands of Johnson's time. Polite conversation and elegant manners were the chief characteristics of an age in which Ches-

terfield was a bright and shining light. Like the "Athenians and strangers" in the time of St. Paul, educated people "spent their time in nothing else, but either to tell, or to hear, some new thing." With the dull, hard-working, unlettered crowds, that plodded on in the steps of their fathers and grandfathers, they had nothing to do; and for them they had no educational theories. It is interesting to picture, in fancy, the bewilderment of a Sam Johnson in the learned circles of this scientific and industrial age. Imagine him attempting to join in the conversations of our British and American associations for the advancement of science, or in our halls of exchange, where the active minds of our generation do mostly congregate. He would find it difficult, in spite of the wonderful vigor of his intellect, to be either useful or ornamental, tho he could easily be amusing.

But how many there are who still cling to the educational creed of Dr. Johnson! Ruskin, thinking to be sure of the same class of people as Johnson, says that the greater part of the education of a gentleman consists in a knowledge of history and the ancient classics. There was a time when a medical student must read Galen in the original tongue: hence he must have learned Greek, and he must write his prescriptions in Latin. The student of theology must read the Bible in Greek and in Hebrew; the law student must read in the original Latin the *Corpus Juris* and the *Institutes* of Justinian; the student of philosophy must translate for himself Plato and Aristotle, and all scholarly productions were to be written in Latin. The learned professions were then properly so called, for their requirements separated them from all other avocations.

But the times have greatly changed. No student, medical or otherwise, reads Galen. Galen's theory of medicine was founded on Aristotle's theory of the constitution of matter; and when, after standing as unquestioned authority for a thousand years, the theory of Aristotle fell before modern science, the theory of Galen fell with it.

As to studying Greek and Hebrew for the better understanding of the Bible, it should be generally admitted that such is not the case. The average theological student, on the contrary,

learns his Greek and his Hebrew from his Bible. The force of a Greek particle, and the exact meaning of a Hebrew dot or dash, he gathers from the context in the "King James" or the "Revised" translation.

Thus are the tables completely turned in classical study. We put the meaning of English words and modern ideas into Greek and Latin and Hebrew roots, and then claim that it increases our knowledge of our own tongue to be able to pronounce the classic originals, which we have ourselves clothed with meaning. If one is to read an author in the original, it is obvious that he ought first to learn the language thoroughly, and then read his author; otherwise, he is corrupting the language by giving its words modern significations, and is putting ideas into his author's head which he never dreamed of.<sup>1</sup>

But this is a digression. I have no wish to oppose the legitimate study of Greek or Hebrew or any other dead language. In fact, I approve the study of at least one inflected language (though not for the sake of thoroughly learning it, or for reading its literature in the original). But I do desire to call attention to two things: first, that the former utilitarian motives for the study of the ancient languages no longer exist; and secondly, that the usual utilitarian arguments adduced for the present superficial study of those languages — viz., to throw light upon the meaning of modern words derived from those early roots — are exceedingly weak or altogether void. I do not deny that it is reasonable and satisfactory, as a mere matter of curiosity, for one to know why a telephone is so called; but I do deny that it adds one particle to my knowledge of a telephone to know that the name was coined from two Greek words.

It must be remembered that what I mean by *knowledge* is not, in a case of this sort, to be derived from books. To really *know* what a telephone is, is an achievement of no small impor-

---

<sup>1</sup> I remember hearing a teacher dilate upon the value of derivations for giving information as to the force of words. He instanced the word "cosmopolitan," and pointed out *cosmos* from κόσμος, "world," and *politian* from πολίτης, "citizen;" hence *cosmopolitan*, "a citizen of the world." Now it was evident, that his idea of the force of πολίτης was obtained not from Aristotle, or from Demosthenes, but from the English word *citizen*; and his notion of κόσμος was derived from his antecedent knowledge of the very word, *cosmopolitan*, which he was trying to define.

tance, and is utterly beyond the horizon of both Aristotle and Socrates; but that knowledge gained, it is absurd to suppose that the *name* of the instrument can add either force or clearness to one's conception of the *thing*.

It is only when one has no means of information, except the name, that it gives any information. Of course such information is exceedingly inadequate, and ought never to satisfy. The tendency of philological study is to accept derivation as a sufficient explanation of the force of words. In my opinion, there is much to be said on the other side. Take, for example, the word *citizen* used above. Is it helpful or not to the *present exact meaning and force of that word* to know that it means, etymologically, "one belonging to a city"?<sup>1</sup>

Education is too large to be enclosed in the walls of a school-room; hence I shall speak chiefly of *school* education, and I shall not attempt a new definition of even that. We are pretty well agreed on certain elements and spheres of development.

The universe has two spheres, — one of matter, the other of mind. To be prepared for one's work in both, one must be trained in both.

Perception, memory, and judgment are to be developed, cultivated, and trained.

These mental faculties, however divided and subdivided, are to be treated in a rational manner, that the mind may possess what we call *power*. This is the choicest fruit of education; and it may be secured — that is, we may suppose that it is secured — through the instrumentality of a universe, both of matter and of mind, quite unlike the one in which we live, — a universe whose physical and mental laws and facts and phenomena are different from ours. But a being thus trained would possess *power* only in the sphere in which it had been trained. In another and different universe it would be powerless.

Consider for a moment the condition of a being, say an angel

---

<sup>1</sup> I once read an elaborate essay which was mainly occupied in attempting to make the meaning and the present demands of *education* clear to an audience of American teachers, by discussing the meaning of *educere* as used by Horace and Cicero.



from the heights of heaven, a bright, intelligent spirit from that celestial sphere where our material, sensuous laws do not obtain, transported for the first time to this earth, and incarnated as we are. How utterly *powerless* would this powerful being be! He would not know the meaning of a single sight nor sound, odor nor flavor; he would not know up from down, heat from cold, heavy from light, long from short; he would be, in truth, as helpless as an infant, and he could begin life here in no way but as an infant. In fact, he could begin only as we began; grow in knowledge and power as we grew; develop and acquire culture and skill as we have acquired them. Bacon was then right when he said that Knowledge was Power. The things we really *know* are not the things we have merely read about or heard about, but the things we have lived, have experienced, have been sensible of. All that the angel could bring from another sphere is capacity for power, not power itself. Power over things external to one's self can come only through growth and personal experience of external things, as an oak can come from an acorn only by going through the whole process of growth.

A knowledge of the facts, phenomena, and relations of the mental and physical worlds in which we are to live is, then, the basis of our power; and in so far as we devote ourselves to the acquisition of facts or to the observation of the phenomena and relations of other worlds, or of imaginary worlds, which are unlike ours, then so far our labor is without fruit.

Now, a thousand to the contrary notwithstanding, I insist that public education should aim to develop power,—power to take care of one's self, power to discharge one's duties to his family and to the State, power to make the most of one's self.

How shall this power be developed? One says by studying the orators, poets, and historians; another says by learning to read, write, and cipher; another, by learning to shoot, to ride, to row, to sail, to swim, to vault, to box, to run races, to drive a four-horse chariot; still another says power is to be developed by going into the streets, and sharpening one's wits by contact with all sorts of men; and another, by going into the fields, and studying plants and insects, the earth beneath his feet, and the

heavens above his head. In all these paths powerful men have walked, and their admirers have not been slow to claim for each method in turn a preëminent value.

A judicial mind at once sees that all are right, and all are wrong. It would be clearly unfortunate to train all by any one of these methods. Power is not all of one kind, and the world wants a great variety of powers; and some who would fail by one road may succeed by another.

But how is one to know which path to take without first trying them all, since not the road alone, but the traveler is to be taken into account? Clearly, intelligent choice can be exercised only when the chief characteristics of both roads and traveler are fairly comprehended. Education, then, must be "all around," and many-sided, unless the right of choice is denied. At this point I think we can all agree. But now comes the question: How much of this must the school undertake, and how much must be left to the home and other influences? Here we shall differ. One points to the past, and says, "Thus did our fathers, and so must we"; as tho we, who refuse to do other things as our fathers did them, and who persist in doing a thousand things which our fathers never dreamed of, must still conduct school education in the old-fashioned way. To speak truly, it is as absurd to consult Plato or Cicero or Milton or Samuel Johnson or Benjamin Franklin or Daniel Webster as to how we shall teach school in this year of our Lord, 1887, as it would be to consult them as to how we shall build our houses, cultivate our crops, fight our battles, travel over land and sea, communicate our thoughts, light our streets, or amuse our children.

"In these days of repeating rifles, Harvard sent me and my classmates out into the strife equipped with shields and swords and javelins," said Charles Francis Adams, Jr., in his remarkable Phi Beta Kappa address. "We can not continue in this age full of modern artillery to turn out our boys to do battle in it, equipped only with the sword and shield of the ancient Gladiator," says Huxley, using the same striking figure.

Sir Lyon Playfair changes the metaphor, but is none the less expressive. What he protests against is not literary study, but

the exclusion of those modern subjects which bear directly upon the duties and responsibilities of life. He says, "In a scientific and keenly competitive age, an exclusive education in the dead languages is a perplexing anomaly. The flowers of literature should be cultivated and gathered, tho it is not wise to send men into our fields of industry to gather the harvest, when they have been taught only to cull the poppies, and to push aside the wheat." (British Association Address, 1885.)

Another says we must teach mainly the love of the beautiful, while the useful must be left to take care of itself: so he urges the study of art and music and poetry and eloquence; beauty of form, life, and manner.

Another declares that a school is for intellectual training, and that neither morality nor a preparation for the business of life is admissible.

Another declares that a thorough preparation for the business of life is the main function of a school. And so on.

In an industrial, scientific age, in which ecclesiasticism is either dead or dying, in which monarchism is fading away with the decay of the warlike spirit, in which all men are equal before the law, — we must invent, among other inventions, our institutions of education. Nothing can be more appropriate than the figure about putting new wine into new bottles, if we could preserve the wine. What, then, shall the school attempt to give?

There can be no question about the three R's,<sup>1</sup> tho I can not refrain from urging that children shall not be taught to read or repeat language which they do not understand. As soon as they learn by any rational method a new word or phrase, let them learn to write it, and to recognize it at sight, whether in print or in script. And in arithmetic let the abstract methods be applied in concrete examples as frequently and as variously as possible. The two cautions I would urge are: that instruction in arithmetic should be carefully graded to the ability of the pupils; and that the slang of banks, brokers' offices, and

---

<sup>1</sup> "The uneducated look upon reading and writing as education. There is an age when these become practically indispensable, but they do not in themselves educate; they are simply its instruments, the most potent ones." — MRS. HORACE MANN.

halls of exchange be excluded. This slang, which soon becomes the *technique* of trade, has no more place in the schoolroom than have the legal phrases of the lawyer, the medical terms of the physician, or the technical vocabulary of the engineer.

Neither should there be any difference of opinion as to the propriety of studying literature, geography, and history, as pupils become old enough to do so with profit. By all means give them Bryant and Milton and Longfellow and Shakespeare and Homer, and give frequent, nay daily, practice in writing English, after the model of our best prose writers. Do not be afraid to teach pupils to consciously imitate good prose writers one after another. Do not be afraid of thereby preventing the formation of an original style. Most original styles should have been prevented, in my opinion. If one finds that the style of an Irving, an Alcott, a Howells, or an Addison meets his wants, by all means let him keep it. If he wants more, he will certainly find it himself.

But shall we stop here with our curriculum? Shall we omit a systematic study of the elements of natural science, by the rational method of *things* before *words*? Shall we forget that the pupils have hands as well as eyes and ears? Shall we exclude all tools, because the pen has been declared the mightiest of weapons? In this forceful age, when we do few things directly, and most things by instruments, by tools, by mechanism, by directing the willing forces of nature until one "skillful hand and cultured brain" can outdo a thousand Grecian or Egyptian slaves,—shall we refuse that MANUAL TRAINING which should be one of the inalienable rights of an American youth?

But to be more specific. There are many who agree with me in regard to the necessity of manual training, particularly for city boys, who nevertheless see no way for securing it at school. They take it for granted that school is the place for intellectual and moral training through the medium of books alone, and that hand training lies outside the proper functions of the school.

In his essay<sup>1</sup> on English in schools, among much most

---

<sup>1</sup> Published as an introduction to *A Midsummer Night's Dream* and *The Merchant of Venice*.

excellent matter, Dr. H. N. Hudson, the Shakspearean critic, says : —

“ But I suspect our American parents have become somewhat absurdly, and not very innocently, ambitious of having their boys and girls all educated to be good for nothing ; too proud or too lazy to live by hand work, while they are nowise qualified to live by head work, nor could get any to do, if they were. If they would in all meekness and simplicity of heart endeavor to educate their children to be good for something, they would be infinitely more likely to overtake the aim of their sinful and wicked ambition.

“ So long as people proceed upon the notion that their children’s main business in this world is to shine and not to work, and that the school has it in special charge to fit them out on all points, just so long they will continue to expect and to demand of the school that which the school can not give. . . .

“ It is, then, *desirable* that children should learn to think, but it is *indispensable* that they should learn to work ; and I believe it is possible for a large, perhaps the larger, portion of them to be so educated as to find pleasure in both. But the great question is, *how to render the desirable thing and the indispensable thing mutually helpful and supplementary*. For surely the two parts of education, — the education of the mind, and the education of the hand, — tho quite distinct in idea, and separate in act, are not, or need not be, at all antagonistic.”

Dr. Hudson thought that the school should give the “head” training, while the home should give the “hand” training ; hence his phrase, “separate in act.” In point of fact, mental and manual training are closely allied, and should generally be *combined in act*. All manual training is more or less intellectual. To be sure, there is very little mental exercise in penmanship, or “fingering” at a piano, as there is in the musculature of the gymnasium ; but tool-work is of a much higher grade, and is more nearly analogous to English composition and to instrumental music.

Rev. Edward E. Hale has pleaded eloquently for more practical training, which he also assumes is to be given at home or during vacation ; and for the purpose of securing better opportunities for such training, he advocates either half-time schools or longer vacations.<sup>1</sup>

Mr. Hale’s position is so extreme that it almost answers itself. I am as familiar with the fortunate circumstances of a

---

<sup>1</sup> See “Half-Time Schools,” *North American Review*, November, 1883.

farmer's boy as Mr. Hale. I have tried the school winters, and the farm summers. I know the value of a country training, where a fond father is never tired of giving sound instruction, and encouraging high aspirations. But the evils of which Mr. Hale complains are chiefly found in city schools; they have small foothold in the country. Not one per cent of the fathers in a great city can command the facilities for teaching what he says every boy ought to learn at home during vacation. Just hear him!

"He must know what a bushel of wheat was when he saw it, and how a blacksmith shod a horse. He must learn the methods of a town meeting. He must know how to milk, how to plow, how to cradle oats, how to drive, how to harness a horse, how to take off a wheel, and how to grease an axle."

It is excellent to be highly accomplished, of course, but could he not with equal propriety have said this?—

"He must know a salmon when he sees it, and how the sailor splices a rope. He must learn the discipline of a ship. He must learn how to dress a fish, how to set, reef, and furl a sail, how to row and scull a boat, how to swim, and how to stop a leak."

The city boy is more likely to learn these than those; yet, if he spends his vacation at home, three-fourths of it is worse than wasted. No time is so fruitless of good, so fruitful of evil, as the long vacation. The father generally works under such conditions that he can neither employ nor entertain his son during the day. The restraints of home are soon outgrown, and the boy is on the street, guided by "that good master himself," learning the ways of the world under the worst possible auspices.<sup>1</sup>

The answer to the question, What more shall the school undertake to do? should depend upon what, in the interest of

---

<sup>1</sup> "The majority of our people now reside in cities or large towns. The boy when out of school, can no longer resort to the carpenter's bench in the barn; for there is no barn, not even a wood-shed, only a coal-cellar. He may, at times, be found in a vacant, unfilled lot, having a very poor time playing a very poor game of ball; now and then he may make a laborious expedition to some park or skating-pond for amusement; but during the most of the time he has no resort outside the house except the sidewalk." — **PRES. F. A. WALKER.**

economy, individual progress, and public policy, the school is able to do.

Mr. Hale assumes that it is for intellectual discipline alone, and that this is to be gained by reading, writing, and arithmetic. All else, whether music, literature, sewing, drawing, or object lessons, are out of place. When there are so many things as intellectual as penmanship, and as practical as banking and equation of payments, which every boy and girl should know, is there any good reason for limiting school education to the three R's? Is it any reason that it was so once? When Daniel Webster<sup>1</sup> was a boy, there was not a railroad, nor a telephone, not even a telegraph nor a steamboat, in the land. Our present methods of supplying cities with food, with fuel, with shelter, with clothing, were unknown. There was not an armored ship, nor a breach-loading gun, nor a dynamo in the world; there was no theory of evolution, no modern science as we now understand the term, and one-half of the present occupations of men did not exist. Are our schools to be conducted in blissful ignorance of all this? Can the ordinary parent teach his boys how to cradle oats, to make a working drawing, to braze two pieces of iron, to make and temper a chisel, to frame a joint, or to make an electric battery, more readily than he can teach him how to read?

Secretary Dickinson of the Massachusetts Board of Education has taken the ground that the chief function of a public school is to prevent illiteracy by teaching reading. After reading, writing and arithmetic should have place; but in no direct way is it the aim of a public school to fit a boy to earn his living.

From a recent utterance of Prest. Francis A. Walker, partly in reply to Secretary Dickinson, I quote a word as to the proper function of public schools and the value of tool-instructions:—

“It is at this point that we part company with Dr. Dickinson. He would trust to the continued use of drawing, and to the increased use of science-teaching, to train the senses, to cultivate the habit of observation, to strengthen the judgment, and to make the hand and eye more ready and

---

<sup>1</sup> Mr. Hale's readers scarcely need be told that Daniel Webster is one of his heroes.

faithful servants of the mind. The use of tools he deprecates as injurious to the proper purposes, and as disparaging to the dignity of the public schools; while he admits sewing and cooking only as burdens which the schools may be asked to carry for the general good. Most of us, on the contrary, believe that the use of tools in appropriate form and degree, and the teaching of cooking and sewing, are as truly educational as any, even the most approved, of the familiar features of the public school; that they supply desirable elements which can be obtained at all, or which can be obtained as well, FROM NO OTHER SOURCE; and that they are not only compatible with the integrity and dignity of the school system, but that they promise greatly to increase the general interest in the schools, if not to become the very salvation of the school system itself; while the *incidental* advantages resulting therefrom:—

In raising the industrial quality of our people;

In creating respect for labor;

In quickening the sense of social decency;

In securing a greater economy of the means and the resources of the very poor: and

In promoting good citizenship generally—  
are, as we esteem them, beyond all price."

Dr. Dickinson appears to me to think that the only outcome of tool-instruction is mere manual dexterity, which he thinks has no value as a means for promoting "the general development of active power." As to the need of a larger development of active power than now obtains, "of turning the learner's mind from words to things," he appears to be convinced. He says truly that "it should not be forgotten that the conditions of knowledge require the presence to the mind of the objects and subjects to be known, and that the cultivation of active power requires a vigorous exercise of the faculties upon appropriate objects of thought." He admits that "the pupil may become an original investigator by being trained to handle the objects of his investigation. This training leads to self-control, and prepares one to take up the work of life with every prospect of success." (*Education*, June, 1887.)

That is good sense, tho it seems a little ambitious. Still, will the training be without value if the objects investigated include woods, metals, tools, and fabrics? And suppose he does more than "handle" them? Handling things is a great deal better than nothing; but to me, the word suggests a very



superficial treatment. In addition to handling a piece of wood or a piece of plaster, an instrument or a tool, suppose he probes it, and tests it, and finds out the secrets of its construction, and some of its manifold uses, is it not far better than any mere "handling" can be? And is it fruitless if such investigation be not original? It is a high ambition to be original, to invent; but very little of a pupil's work can be original. He follows beaten paths in more than one study. But the work he *does* is original to *him*, in so far as he is conscious of doing things, of solving things himself; and original work of that sort, in any field, is stimulating and nutritious to the mind.

I am bound to believe that Dr. Dickinson has been misled as to the motive of shop-work in schools of secondary grade, he is so afraid of trade or professional teaching, — a thing which I suspect very few thoughtful people advocate in any public school, or school for general training. And, again, I see plainly that he completely fails to appreciate the fact that the fruit of judicious tool-instruction is mental dexterity rather than manual dexterity.

I find myself in entire sympathy with the secretary's final statement of the end and aim of public instruction; we differ only in the means to be employed. He says: —

"If we desire to construct such a system of public instruction for the youth of the country as will best prepare them to discharge, with efficiency and fidelity, the duties of private and public life, let us make ample provision for the complete training of the powers of observation, for an accurate knowledge of facts, of analysis and comparison, for a knowledge of the relations of things, of generalization and reasoning, for a knowledge of those general truths from which the rules of conduct should be derived, and, above these things, for that training which leads to an all-controlling love of truth; and the youth will take their places in life, elevated above the narrowing effect of any trade, occupation, or profession, and ready to enter upon any service to which they may be called."

Amen, and amen! and by their fruits ye shall know them. I am no stranger to Dr. Dickinson's method, either as a pupil or as a teacher; but I greatly fear that he is a comparative stranger to mine. If he would take one half the Boston boys who this year complete the grammar school course, — and there ought to

be about two thousand of them, — and train one half of them his way, and one half of them my way, for three years, and then graduate them, and watch their careers for ten years more, I am sure that he would agree with me, that there is not a single element of narrowness, or unmanliness, or unworthiness in manual training.

Prof. Ripper of Sheffield, Eng., whom I have already referred to in an early chapter, says: —

“There is at present absolutely no sort of connection between the school-room and the workshop; between the present training and future employment of boys. Work, workshops, tools, materials, or workshop problems are never mentioned in the school; they have no place there; all reference to these things is excluded as a sort of necessary evil which it will be time enough for the children to deal with when they are obliged. But the present grinding, aimless system of mere book-learning and cram is not destined to live much longer in its present form.”

The ambition of American parents, of which Dr. Hudson complains, is not then an American invention; we have it by honest inheritance. When school education was the prerogative of the rich and “high-born,” nothing could be more reasonable than that their schools should aim to produce gentlemen of leisure, with polished manners and “polite” learning. The strange thing is, that, when we adopted the principle of universal education, we clung so tenaciously to the old curriculum, and blindly hugged the delusion that we were all noble, all destined to lives of elegant ease among cultivated people.

Such being the fact, what is the inevitable consequence? Why, to most people the education we provide in our secondary schools seems like giving stones to hungry children who are crying for bread. The great mass of the people think, that, beyond the rudiments, school education is not worth the getting. The average child takes less than half the course. The extent of one’s school education is generally determined by social considerations. The higher grades become therefore more “select” in the genteel sense, and both the patrons and managers of such grades are interested in maintaining their genteel character.

The class of schools which the city of St. Louis ought, above all others, to maintain in the interest of economy, of self-defence,

of benevolence, and of public decency, is not maintained at all. I mean schools for the ragged, neglected, little outcasts, who wander homeless about our streets, and form the recruiting ground for hoodlums, thieves, and criminals; who fill our jails and work-houses; and who cost us per year as much as we now pay for our system of public schools. It is a shame that *public education* shoots above the heads of all such!

I do not wish to ignore the fact that much has been done in the direction of adopting a program more consonant with our platform of universal education. The demands of the age were, a few years since, recognized by a wide-spread attempt to introduce both natural science and "industrial" drawing.

The science study is in a very hopeful state, tho it has suffered greatly from incompetent teachers, whose knowledge of science consisted of a few feeble ideas gathered from books, and from a complete lack of that manual skill which is absolutely essential to the successful study of science by the method of "*things* and *processes*." Moreover, it has materially helped to make clear the demand for skill of manipulation as the condition for science study. Drawing has in many places made splendid progress, but it has failed as a general thing to take on a universal character. It has on the one hand been specialized into what was largely imitative drawing, given in the evening to those who were at work during the day; and, on the other hand, it has been crowded over into the atmosphere of artistic drawing as more consonant with the general air of gentility in the other work of the school.

I have often elsewhere spoken of the comparative inutility of drawing, when not supplemented by laboratory work on wood, plaster, clay, or other suitable material. No teacher, who, under favorable conditions, has added executive, constructive work to drawing, can be for a moment in doubt of its beneficial effect upon the drawing. The following very thoughtful remarks of Supt. Edwin P. Seaver of Boston show the result of his careful observations.

"As now pursued, drawing has but a vague and remote reference to any use beyond itself. When this branch was introduced into our schools, and made obligatory by statute, the plea was, that drawing was an important

part of industrial education, and industrial education was much needed by the people, especially the people in the cities. This is all true, and very well as far as it goes. But abundant experience may be cited to show that industrial education through drawing alone is work only half done, and that it has for that reason usually failed. The other half — modeling, carving, joining, turning, forging, casting, weaving, or any other process by which material is shaped in accordance with a preconceived design represented by drawings — has hitherto been wanting in our schools. Unless this element of construction is added, our drawing will still fail, as it has hitherto failed, to yield the full measure of good results expected of it. Delineation and construction — designing and the working out of the design — are two parts of one whole; neither can have full educational value without the other. The former, pursued alone, is open to all the objections that may properly be urged against any abstract studies imposed on children; while the latter, pursued alone, fails to give the worker that broad, intelligent grasp of the plan of his work, which is a necessary element in all true skill."

I cheerfully grant that much good has been accomplished by these movements, though I regret the use of the word "industrial" in connection with drawing. Drawing is scarcely more industrial than arithmetic, or chemistry, or physics, or penmanship. Nevertheless, "industrial" drawing has helped to prepare the way for the broader and more comprehensive system of manual training which it has been my privilege to help introduce. This is not brought forward as an exclusively industrial feature, and I decline to call a manual training school an industrial school. In it we have endeavored to bring together the education of the hand, and the education of the mind, in such a way that each is the gainer thereby. And we have found it possible to bring together into one the two educations which some have thought it necessary to separate. In other words, we have extended our scheme of education so as to include those manual elements which are of universal utility in the education of youth.

And we have discovered, — and here is the principal point in the discussion, — we have found that these manual elements can, at the time they are most needed, be as successfully and economically taught in the schoolroom, by ordinary class methods, as reading or arithmetic are taught, and vastly more thoroughly and cheaply than the manual elements can be taught anywhere else. The burden of complaint has been that they have not

been taught at all anywhere. There can be no comparison between two systems, one of which succeeds, while the other fails.

But it may be urged, that, in well-to-do families, children are sometimes given manual instruction at home, and that the sons have received a species of manual training as apprentices in a commercial establishment. It is thought that these methods are better than the method I recommend. Let me examine them.

Against the results of the family method, nothing can be said *if it is well carried out*. It *may be* thorough, generous, and wholesome in every way. It may possibly lack the spur and stimulus of a score of other minds, what Dr. Harris so admirably calls the "leverage of the class." But it is exceedingly expensive. None but the rich can give what we place within the reach of all. The cost of a private tutor always exceeds tuition fees and school taxes; much more would home manual training exceed its cost in a good school. But the supposition that home manual training is well done is quite unusual. Suppose, rather, that a father does his best, and teaches his son the petty details of his own craft or occupation. On the average, how wretchedly *narrow* that training must be! In the average family, the parents are incompetent to teach much that it is highly desirable that the children should learn even of their own occupations.

"The specialization of manufactures has been carried so far, that, in some departments, an operative often need not be a mechanic in any sense of that term; using only a single tool, and performing only a single simple operation from one year's end to another. Even the mechanic arts have been differentiated, until individual skill has largely gone out of them. The carpenter of the old days made sash, doors, and blinds; he planed, matched, and grooved his boards; he built his stairways; he did a hundred things requiring dexterity and fine workmanship.

"To-day few of them are capable of giving their children that instruction in mechanic arts which every father in the olden time gave his boys as a matter of course. Such, and so extensive, have been the changes in the social conditions of our people."—PREST. FRANCIS A. WALKER.

Go into the first public school you see, and learn the occupations, or crafts, or callings of all the fathers of the boys therein.

You will find that one half of them have no well-defined craft or professional training. You will find under the head of "clerks" and "laborers" two thirds of the whole number, if correctly reported. Now I say, suppose these men do teach their sons just what they themselves know, what a sorry preparation they have for an intelligent choice of occupation! It is clear that they have no choice at all. It is merely the European idea of an inherited occupation, and must ever result in the establishment of the worst kind of caste distinctions.

The experience of Europe has abundantly shown that home training for life not only perpetuates caste, but degrades the industries of a people. They have found that even when a father has a trade, and wishes to teach it to his son, he can not teach it as intelligently and thoroughly as it can be taught in a trade school.

Hence a school is better than home training in handiwork. I will now show that a manual training school is better than any system of apprenticeship, and hence better than any trade school, for the purpose of general training.

To the commercial method, of more or less formal apprenticeship, several very serious objections arise. First and foremost, the apprentice stops going to school. His mathematical, scientific, and literary training stops the moment he enters upon his effort to secure manual training. This fact alone ought to kill the old style of apprenticeship. It has degraded all mechanical pursuits, — not simply brought them into bad repute, but has actually degraded them, — and has given rise to the notion that a mechanic *needs* no education beyond the rudiments of the grammar school, aside from what he picks up at his trade.

Then, again, in apprenticeship at any kind of tool-work, the boy is not taught drawing as a part of his trade; and yet tool-work, however skillful, without drawing is the thinnest sort of apology for manual training. Not one journeyman mechanic in a hundred is as good a draughtsman, or as intelligent in reading drawings, as the graduate of a manual training school.

Thirdly, the ordinary apprentice gets at best a very narrow kind of manual training. He is made familiar with a very limited range of work, and he is kept at that far beyond the

needs of intelligent mastery, till the mechanical habits of a rapid workman are fully formed. Henceforth his handiwork is the result of habit, not of thought, and his intellectual progress as connected with his work is at an end.

Can the value of such a training be compared with that given in a school where the intellect is ever on the alert, and where we introduce the widest possible range of tools, materials, and processes?

But it may be urged in reply to all this, that the apprentice is all the while earning some money; and, again, he is saving much time by getting into good paying employment.

There is truth in the first objections. The apprentice usually does get, I am sorry to say, some pay even for the first year. It may be only fifty dollars, but it is something; and it works badly in two ways. On the one side, it reconciles the parent, who may be very poor, or lazy, or indifferent to the boy's highest welfare, to a very poor and unprofitable arrangement, and it may gratify the boy's dangerous appetite for spending money; on the other side, it appears to justify the employer in keeping the lad at unprogressive work, on the plea that he should earn his wages.

As to the saving of time in reaching good wages, it is very doubtful if such is the case. It is the bird in the hand in preference to several in the bush. Take the boys who have been out of the St. Louis Manual Training School a year and a half, and who consequently entered school four years and a half ago: how does the average of their wages compare with those of average journeymen mechanics who began their apprenticeship four years and a half ago? And how will it be five or ten years hence? (See p. 156 as to the wages actually received by manual graduates, and Mr. Foley's testimony, p. 198.)

But there is a fourth argument against the commercial way of getting manual training, which to some may outweigh all the rest, serious as they appear to be; and that is this: To put a boy fourteen or fifteen years old to learn a trade as an apprentice, is, as a rule, to commit him to that trade for life, without intelligent choice of occupation, and with little chance for correcting a mistake if one is made. It is a crime against freedom

and humanity. Few people, not forced by cruel necessity, are willing to take such serious risks, for such questionable gain.

There are plenty of people whose mental make-up is such, that, while they may succeed fairly in other paths of labor, they are unfit to be mechanics. They have not the ability, the proper mental qualities. To set such people to learn trades, is most unfortunate. They are sure to be low-grade, indifferent workmen, always struggling against a fate which a better knowledge of their capacities would have avoided. The fact is that, until one has had an opportunity to develop his faculties, neither he nor his teachers can tell what his "bent" is, nor what there is in him.

The student of a manual training school takes all his work without bias. There is no presumption either for or against a particular line of work in life. He is as free as it is possible to be. He probably changes his mind every year on the subject of what occupation he is best fitted for. At the end of his school course, however, he is likely to see clearly where he is weak, and where he is strong, and to make his choice in the direction of his strength.

To sum up the objections against the commercial method of getting manual training as compared with the school method:—

1. The apprentice gives up all further mathematical, scientific, and literary training.
2. He fails to learn practical draughting.
3. He gets a very narrow training, limited to the details of a single trade, often less than a single trade.
4. He hazards all on a single choice of occupation, without trustworthy knowledge of his abilities or his tastes.

The conclusions I reach may be thus concisely stated.

1. Every child should have systematic mental training and manual training.
2. These two kinds of training should be given side by side, and simultaneously in school.
3. The manual training thus given is far more thorough, far more valuable, and far better supplemented by other culture, and is gained far more cheaply than that gained in any other way.



I am not unacquainted with the various objections urged against the introduction of manual training in public education. Some claim that it would introduce the idea of caste. Such people do not realize the extent to which caste already exists in connection with education. The very objection suggests that in the mind of the objector manual training is socially low-grade, as compared with ordinary academic training. In point of fact I doubt if such is the case to any great extent; and to the extent that it may be true, it is the result of a false estimate of what manual training is. I doubt if in any well-organized manual training school, or in the community around it, there has been any increase of the caste feeling in consequence of the school. On the contrary, I believe the effect is just the other way. If there were any force in the objection, it would be seen more clearly in England than here. This is what an English teacher of experience says:—

“It has been charged against those who advocate manual training, that they belong to that class which would deny the workingman’s child a liberal education; and that, by introducing it, we would perpetuate caste and hateful class distinctions. Nothing could be farther from the actual facts. We say, let the education of every child in the United Kingdom be as thorough and as liberal as you can make it, and after that add to it manual training as a practical and useful finish.

“As to its perpetuating caste, we contend that the higher the grade of the school, the more thorough should be the manual training; and we believe there are few things which would more effectually break down fashionable contempt of manual labor.”

Some persons appear to object to manual training as a feature of general education on educational grounds; and yet, if you examine their position carefully, you will find that the objection is more social than anything else. What is it, for instance, but an inconsistent and ungenerous fling at manual training, to discredit, on the one hand, the claims of systematic tool-instruction as one of the features of general education; and then, on the other, to assert that “in schools for Indian youth, freedmen, the blind, the deaf, orphans, paupers, truants, etc., it is wise and important to combine general and industrial training”? I am quoting the exact language of Supt. E. E. White of Cincinnati.

You see Mr. White classifies people, and says it is wise to give manual training to some, but not to others; and the basis of his classification is not intellectual nor moral — it is social. Take the fifteen hundred orphans at Girard College in Philadelphia; they are between the ages of six and sixteen. Mr. White says it is wise to mix manual training with their mental training. So say I. What would Secretary Dickinson say? Now, why do Mr. White and I say, combine manual with their mental training? Evidently, because we believe that such a combination is most likely to accomplish the high ends so well expressed by Dr. Dickinson. Now if it be true, as Mr. White and I believe, that the high aims of education are best secured to those fifteen hundred orphans by such a combination, why will not those ends be equally well secured to fifteen hundred other Philadelphia boys who are not orphans?

Here Mr. White and I part company. He says, the moment you step into a school where the boys are not orphans, or truants, or paupers, or negroes, or Indians, it is no longer wise and important to combine mental and manual training; the mental is better alone. I say no — a thousand times, no. Let us give the best we have to all, whether it be the old or the new. Away with all such social distinctions. In his language, if not in his thought, Mr. White reflects upon the character and social standing of manual training. He would have it appear that it is not good enough for respectable boys; and when he sandwiches the unfortunate between truants and paupers on the one hand, and freedmen and Indian youth on the other, I can not avoid the conclusion that he thinks that it is not respectable to be an orphan, to be blind, or deaf.

I protest against the tendency of Mr. White's position.

And when Mr. Dickinson declares against the method of manual training, which I have found so fruitful in good results, educational and economical, I can not avoid asking, What sort of boys is he thinking of? Is he thinking as fully and impartially of those who are to carry on and direct and develop the thousand and one mechanical occupations of the next twenty-five years, as he is of those who are to devote themselves to literature and art and science and to professional life? The

manual training school thinks as much of the one set as of the other. The children of the people for whom public education is provided, in whose service you and I are engaged, do not all wear kid gloves nor eat with silver spoons. Let us so train them *all*, that they will be strong and self-reliant, independent and free. Let their education be first broad and generous, before it becomes special. Let us make it thoroughly human by developing all their God-given human faculties and sympathies symmetrically; in short, let us put the whole boy to school.

Others claim that a manual training school is a "special" school. If it is special to omit Greek from its curriculum, and to give but one-third of the book study to language and literature; if it is special to give but a moderate attention to commercial arithmetic and book-keeping; to give more than the usual attention to elementary science, and at the same time an equally moderate attention to practical drawing and the principles and processes which underlie half the occupations of our people, — then the manual training school is a special school. But certainly it is no more special than, for instance, any one of the high schools of Boston. That city has a "normal school" for girls, with special reference to teaching; a "Latin High" for boys, with special reference to being lawyers, physicians, or clergymen; and an "English High" for boys intending to enter mercantile life. Such schools may be right and proper, and be demanded by the needs of a great city. For them she does not and ought not to shrink from spending large sums of public money.

But what equally generous provision does she make for those other Boston boys, who out-number these several times over, and who need, and are capable of receiving, *some* preparation for the business of *their* lives? None. These boys must either go to their work with no training beyond that of the grammar schools, or they must content themselves with the preliminary training of a lawyer or a merchant.

But I do not admit that a manual training school is a special school. It is the "Latin" school and the "English High" that are special. Take a list of the Boston boys between fourteen

and eighteen years of age, and see how many of them need Greek, and how many need manual training. Then take the graduates of a high school and of a manual training school which have stood side by side long enough to afford a basis of comparison, and see which set of graduates has scattered most widely into occupations requiring cultivated brains.

No, I am clearly of the opinion that the high school people have no right to call the manual a "special" school. It is not special to train the whole boy, except as a historical fact.

Mr. Thomas Davidson in the *Forum* for April, 1887, comes to the conclusion that my position is altogether correct. He says:—

"It appears to me, that, for a very large portion of our people, manual training is one of the very first of educational necessities. I am strongly in favor of public high schools and colleges; but I maintain, that, if any community can not support both high schools and manual training schools, it is bound to give precedence to the latter. Nay, more, if any community now supports high schools, but has no manual training schools, it is bound to exchange the former for the latter, or else maintain both.

"I am, therefore, thoroughly convinced that our public education would, in every way, be a gainer if our high schools and colleges were turned into manual training schools after the model of those in Chicago and St. Louis."

I have said that we do not teach trades; but some people declare that we *do* teach them, or *try* to do so. Such people do not know what is involved in learning a trade. They do not realize that in learning a trade one must learn the business; he must learn the money value of time and of materials. He must learn to draw the line between economy of material and economy of labor in the design and construction of articles. He must learn to compare various methods of effecting the same result, and be able to select the one which in a given case is best. He must be prepared for competition. These things, for the most part, can not be learned at school; and, tho such matters might have a certain value for all persons, it would be manifestly unwise to try to put them into a school.

As regards what we can not and do not try to teach, I will quote a word from that very keen observer and successful man of business, William Mather, Esq., manufacturer, Manchester,

Eng., late Royal Commissioner of Education to America, recently member of Parliament from Salford:—

“There is no possibility of teaching in a school that sort of knowledge which practical work, carried out on commercial principles, within restrictions as to time of execution, etc., can alone make any one familiar with.”  
— *Technical Education in Russia* (p. 12).

#### THE POLICY OF THE SHOP.

I have been criticised because I have refused to entertain the idea of making articles to sell, even when it would appear that I could do so as well as not. Let us look at the matter a moment, and see if I am not right.

Suppose correct translations of Cæsar or Voltaire could be sold at so much a line, without regard to the translator; nay, suppose that the best translations sold for the most money, and that poor work was a drug in the market. Now, if we add the further suppositions, that translations of old passages sell as well as of new ones, and that all the money received goes into the school treasury, you have the parallel conditions under which each and every pupil is to be well and broadly trained in Latin and French.

Under such conditions (assuming money to be an object, and that is what my critics assume), would not the teacher be likely to touch up a great many translations himself? Would he not probably translate all the hard passages himself? Would he not be apt to give the more difficult parts to the ablest boys? And would he not be sorely tempted to keep his class on a few popular selections as soon as they had shown that they could translate them acceptably? Think you the moral effect on the school would be good? Under such conditions I think a good school would be a moral impossibility.

Now there are plenty of good workmen whose only standard of success is the income of the shop, whose only criterion of excellence is salability. The finished work is the grand *desideratum*, no matter how nor by whom made. — Beware of such men. Do not make them teachers of your sons, or give them the control of your school.

Let me make an extract on this point of policy, from a paper

it was my privilege to present to the American Society of Mechanical Engineers at its Chicago meeting in May, 1886, upon "The Training of a Dynamic Engineer." The paper was in part a reply to one by Prof. Alden of the Worcester Free Institute. I said:—

"Prof. Alden believes in a commercial shop where real business is done, and where commercial standards are used. He admits that 'such a plan would not have been developed as the outgrowth of a school,' and says it was made a necessary condition of the acceptance of the donation for the establishment of the Worcester shop. Nevertheless, he appears to regard it as the best means for securing the end sought; viz., the education and training of the students in practical mechanics. According to Prof. Alden, the question is, 'whether the shop shall, *first*, be a place where business is done, in order that there may be something practical for the students to learn; or whether it shall be a place fitted with tools, where only their use and the processes of shop practice are taught.' He decides for the former, I have decided for the latter.

"The *first* thing to do in the shops of a school is to teach the use of tools, and the processes of the arts; the question of what shall be done with the incidental products is a *secondary* matter. Our exercises are so designed that their execution shall be as instructive as possible, and not at all with a view to sale. We can not afford to fill orders: the moment a boy is fit to fill an order involving only old exercises, he must turn his attention to new ones. We aim to put but one article upon the market; viz., *boys*.

"Not that we hold, as Prof. Alden appears to think, that the sale of an article produced as an exercise 'would in some way render the practice unfit to be associated with a school.' We make no attempt to sell their drawings, their surveys, their English essays, their physical apparatus, or their chemical analyses: so we do not aim to sell their shop-work. I think the policy of deliberately manufacturing for the market is unwise or mischievous in three ways:—

"1. The orders which the superintendent can get, and the sequence in which he gets them, are greatly inferior, in the

opportunities they offer for logical treatment and fullness of instruction, to the *orders which he is capable of designing*.

"2. The pecuniary risk involved in the execution of a delicate operation on a large or complicated article is liable to lead the skilled instructor to do with his own hands in every case what each student should have a chance to practice upon for himself.

"3. In spite of all efforts to the contrary, the filling of actual orders is sure to involve not only a dearth of the most instructive processes, but an excess of the simpler steps, continued practice in which ceases to be of any subjective value, and which, therefore, results in a waste of time and loss of interest.<sup>1</sup>

"All of my shop-teachers were trained in business shops, one of them at the Worcester Institute; and yet after several years of experience, in which they have combined exercises of their own design, with the execution of projects more or less complicated and quite analogous to outside orders, they are more and more in favor of their own exercises for the purpose of instruction.

"As regards the interest which students take in their work, we have found no lack of it in judicious exercises. At the same time, we have no objection to putting to actual use such of our exercises as will admit of it. During the past year, every student of the graduating class of the Manual Training School has been required to make, as a lathe exercise, three small and three large bolts with their nuts. Now the first bolt finished was likely to be poor; the last in each set was likely to be good. Such being the case, we had no wish for the class to make more. Our object was secured. We could not stop to make more, even to fill an order. With a full knowledge of all the facts, a St. Louis firm, of whom we bought iron and steel, offered to let us have all the material we needed for this exercise if we would let them have the finished bolts when we were through with them. This offer we accepted.

---

<sup>1</sup> Prof. S. W. Robinson of Columbus, O., added a *fourth* objection to a commercial policy as the result of his own experience; viz., a practical sacrifice of all instruction to the demands of the shop whenever it was necessary to fill orders on time.

## THE STUDY OF MONEY VALUES.

“Secondly, I wish to consider an argument offered by the superintendent of the ‘Miller Manual Labor School’ in Virginia. He says in his catalog of 1885: ‘We consider it part of the instruction of the shop to teach boys the value of labor, the increased value of skilled labor, and the still greater value of an educated mind guiding a trained hand.’ And, again: ‘We feel sure that no course of shop instruction will be complete that does not take cognizance of the value of material and the value of labor.’ It is probable that by ‘value’ is meant only money value.

“This sounds well, and the objects aimed at are worthy; but I doubt their success in this direction. A learner can get no correct idea of the money value of his time or of the education he is getting. His time is well spent in learning, even if he spends six hours in doing what an expert would do in less than one. Take mechanical drawing, for instance. A boy at school makes but one good drawing of a kind. He knows how long it took him to do it, but he does not know how long it would take him to duplicate it; much less does he know what an experienced draughtsman can do. Speed comes with long practice, which a school ought not to try to give. It is the same with shop-work.

“As to his making a just comparison between skilled and unskilled labor, and between an ignorant and an educated workman, it is clearly out of the question. Only long experience in employing and directing workmen of all grades of intelligence and skill gives opportunity for reliable judgment on these points. Of course, our boys *feel* the difference between knowing and not knowing, between thoughtfulness and thoughtlessness; but the money value of that difference is beyond their horizon. So in their study of political economy they get ideas about wages, and the value of skill, both mental and manual; but such ideas can not be called knowledge until confirmed by personal experience in the real work of life.

“Neither do I think much is to be gained in discussing the cost of materials. Economy may be taught even if the material



costs nothing. We can teach intrinsic values without meddling with market values. The former are permanent, the latter fluctuating.

"It is only when the student is preparing directly for the responsibilities of professional life, that a systematic consideration of market values finds appropriate place.

"Let it be said that there are many things which can not be taught or learned at school. A West Point cadet can not be drilled in the presence of flying bullets and bursting shells, tho exercise under such conditions is the 'real business,' the 'something practical,' which the real soldier must some time learn. The law student argues before a 'moot' court; it is only the lawyer who engages in real business before a real court. So the medical student amputates and dissects dead men, leaving living people to those who, worthily or unworthily, have received their diplomas.

"In like manner, while a school can successfully teach and train students in the details of shop-work, as a matter of applied mechanics and practical mechanism, and as a means for the development of mental power, it will not wisely undertake to train them in the actual transaction of business. Such training lies outside the walls of even an engineering school; and any attempt to bring it in is sure, in my opinion, to result in deep-seated errors, in false estimates, and in a diminished regard for those intrinsic values, those immutable laws, and those permanent factors which are of universal application, and which most reward careful study."

In conclusion, let us not fear to build our own house. Let us not fear to strike out for ourselves when the age demands something new. Progress is essential to life; as Browning says:—

"'Tis a life-long toil till our lump be leaven.

The better! What's come to perfection perishes."

I see nowhere, in either ancient or modern times, a people whose youth have been trained as our youth should be trained. Neither Babylon, nor Athens, nor Rome, with their pinnacles of culture resting on the barbarous foundation of human

slavery; nor the blooded aristocracies of more modern times, buttressed and supported by millions of laborers ground down in ignorance, poverty, and superstition, — none of these can teach us how to educate, construct, and adorn an American citizen. The world's work must be done. Let it be done intelligently and well. No narrow, selfish aim, no prejudice of caste, no false claim of high culture, must mislead our pupils.

Give them a generous, symmetrical training; open wide the avenues to success, to usefulness, to happiness, to power; and this age of scientific progress and material wealth shall be also an age of high intellectual and social progress.

NOTE. Portions of this chapter were read at the Chicago meeting of the National Educational Association, in July, 1887.

## CHAPTER XIV.

## EUROPEAN SCHOOLS.

IT is possible that my readers may wish to know to what extent I am familiar with tool-instruction in other lands, and how far trans-Atlantic theory and practice agree with ours.

In 1885 I spent five months on a tour of observation and inspection of English and European schools of higher and lower grades, visiting them while in full operation.

There have been a great many reports upon these matters, so that I shall confine myself to a brief statement of the comparative values and aims of the several kinds of schools I visited.<sup>1</sup>

In England very little had been done in the direction of manual training.

Finsbury College in London was the only good school I saw following a broad and generous course. The school was planned by Mr. (now Sir) Philip Magnus, and in a small way it was very much like our manual training school. At Sheffield there was a similar but less developed school under Prof. Ripper. Other schools, like the Bradford Academy and the Manchester Technical School, were more nearly like trade schools. In these technical schools no uniform general course of study and practice was followed, but each student had special instruction in special arts with a definite view to a special occupation. For instance, one student would study bleaching and dyeing, another spinning, another weaving, and so on.

Many students took no constructive drawing, and in most cases the evening departments were the main features. As a

---

<sup>1</sup> I can not speak too highly of the reports of the British Royal Commission on Technical Education. Their descriptions are remarkably full, and good judgment is shown in giving the details of all peculiar features.

rule, the manufacturing interests of the town determined the character of the technical instruction. During the year 1885, the Manchester Technical School was changed to the Manchester Manual Training School, but with what success I have not learned.

In Scotland, in the city of Glasgow, I visited a school on precisely the plan of a manual training school, called Allan Glen's Institution. To be sure, the school was small, and its outfit very inadequate, so that the shop practice was greatly restricted; but the principles on which the school was conducted were most admirable. Head Master Dixon's views are well expressed by these few words: "There never has been the least idea of attempting to teach the pupils a trade. The whole object has been to *prepare lads to learn* very efficiently" such occupations as they might subsequently choose to adopt.

It is hardly necessary to say that the mechanical laboratories of King's College and University College, and of the Central School of the City, and Guilds of London Institution are for the instruction of students of much higher grade. These are all high-grade polytechnic schools, for which the manual training school is strictly preparatory. It should be borne in mind that the graduate of a manual training school enters a polytechnic school as freshman.

I must not omit to mention the remarkable workshops of Prof. Stuart in the University of Cambridge. Prof. Stuart is a firm believer in the good mental and moral influence of intelligent manual labor and thorough business methods. He has, therefore, organized in the very heart of Cambridge, and as a part of the laboratory system of the great University, a series of shops in which the students are instructed in the execution of commercial work in wood and iron. Almost from the start, the young workmen are put upon job-work which is secured from the city. He has a wood-working shop for the making of patterns; a molding and casting room, containing a small cupola for melting iron; a machine-shop for machine-work and fitting; and one forge. A rigid system of accounts is kept, and prices are based on the time spent. Prof. Stuart started the shop twelve years ago, at his own expense. He gives his own time

(beyond certain lectures he is required to give as University professor), but I believe that one or two shop assistants are paid by the University. All the other running expenses are met by the income of the shop, according to Prof. Stuart.

Tho not approving the policy of Prof. Stuart's establishment, I have no doubt he is doing a good work among the students. The existence and evident popularity of the department is a most interesting phase in the development of the New Cambridge out of the Old. He had eighty students when I was there, of whom sixty were college men. I fear that were Prof. Stuart an obscure man, instead of a distinguished member of Parliament, the shops, as now managed, would be less successful.

In France, manual instruction is firmly established. Special schools have existed for many years for the teaching of trades and the training of apprentices; and, at present, tool-instruction is given to pupils of ten years and upwards, in all the free public schools of Paris. I visited the apprenticeship school on the Boulevard de la Villette, already described in Chap. XI., and found it in full and successful operation. Its object is to teach definite trades: joinery, pattern-making, blacksmithing, fitting, and the trades of the machinist, the locksmith, and the electrician. After a general survey of the whole field, trying his hand for a week or two at each one, the boy selects one, and henceforth devotes himself entirely to it. Some drawing, mathematical, and science work goes along with it; but it is small compared with ours, while the shop-training is very thorough. Not only is every boy expected to follow the trade he learns, but in practice he does follow it. Only boys who are to earn their living are found there. The idea of taking shop-training as a part of general culture never enters one's head. Probably should a young man apply for such a purpose, he would be rejected, on the ground that he would deprive a poor boy of the opportunity to learn a trade; for the capacity of the school is limited. In all the shops of the school, after a short series of general abstract exercises, the boys enter at once upon commercial work.

The school which has exerted the greatest influence upon public education in Paris is the city free school on Rue Tournafort. This has been established many years, and has shown

how much can be accomplished with pupils from ten to sixteen years of age. I visited it in May, 1885. I was surprised at its slim equipment. In its wood-working shop it had eight small benches with four vises on each, so that thirty-two boys could work at once. In its metal department there were ten vises, one forge, and four or five small lathes. In the modeling and carving room there were twenty boys working at the edge of a long bench, and ten at frames of a very simple character, modeling figures in relief, using either wood, plaster, or clay. The school is well conducted, and its aim is as broad and high as possible. The wholesome effect of its course of training has led to the introduction of tool-work into the elementary grades of all the schools.

I visited one of the large primary boys' schools of Paris, and saw the pupils at their various exercises. It was almost amusing to see the enthusiasm with which the little fellows went to their shop-work. Their benches were small and crude, and very close together; but they served their purpose well. The wood the lads were using was very hard, and I wished they had a supply of American white pine for their first exercises. The teachers were greatly pleased with the moral and physical effects of the training.

The theory of public schools in France is based upon the absolute necessity of the State's providing an education which shall make the poorest class better workmen and more intelligent citizens.

Mechanical laboratories for the polytechnic schools are not to be found in France. To a certain extent in the government schools, students make up the deficiency by contact with actual work. The almost unrivaled chemical laboratories of the Central School of Engineering in Paris are in striking contrast with the scant dynamic laboratories of the students in civil and mechanical engineering.

The splendid Conservatory of Arts and Trades is unrivaled as a historical museum, but it has no working laboratory.

At Chalons, there is one of the three fine government schools for the education of skilled foremen and superintendents.<sup>1</sup>

---

<sup>1</sup> The other two are at Aix and Angers. Two more have been recently established (or are in process of establishment), at Lille and at Nevers.

I was delighted with their plant and method of instruction. For the first time I saw my own school out-done in equipment for shop-work. The young men were much older than ours; all were fine, strong, manly fellows, and there was great dignity and system about all their work. The discipline was very strict; and not a word was spoken in the shops, except by, or to, an instructor, unless two students were working together on the same job, as in the forging-shop. The number and size of the tools were remarkable, and suggested a lavish expenditure of the public money. The students work six and three-fourths hours daily in the shops. This large amount of shop practice shows the bent of the school. The annual cost is from two hundred and thirty dollars to two hundred and eighty dollars per student, living expenses included. One half these students pay nothing; the other half pay one hundred and twenty dollars each.

In Germany the polytechnic schools are of very high grade, tho as a rule they are deficient in mechanical laboratories. In chemistry, and sometimes in physics, their working facilities are fine; but in mechanics they have collections of models rather than laboratories. This was particularly noticeable at Berlin, Hanover, Carlsruhe, and Stuttgart in Germany, and in Zurich and Geneva in Switzerland. At Munich I found the best working laboratory of engineering I saw, excepting those in London. But manual training of a broad character is not to be found in Germany to any extent. The lower technical schools are trade schools. There are immense numbers of these scattered all over Germany, and the industries taught vary with the locality. For instance, there are forty-four trade schools in the duchy of Baden for learning clock-making, wood-carving, hat-making, basket-plaiting, etc. By means of these trade schools, the children of workmen are trained to the occupation of their parents in a very direct manner. With their trade instruction, some general education is given; so that the result is better workmen and better citizens as the years roll on.

At Komatau in Bohemia is the famous royal mechanical school described so fully by Dr. Runkle. It is a school of

secondary grade, and is well furnished with shops and drawing rooms; and all the instruction appeared to be thorough. It can accommodate fifty boys, and appears to be generally full.

I had heard Prest. C. O. Thompson say at Madison in 1884, that the Komatau school was "moribund;" and I was anxious to learn, by personal inspection, how far the statement was justified. I found it vigorous and prosperous. Several more schools on the same plan were being established by the Austrian government.

My criticism on the school was, that relatively too much time was spent in the shop, and that the class method of instruction in tool-work was so little used. The divisions were small, and the pupils were not kept together.

The schools of Holland and Belgium are similar to those in Germany. A boy's career in life is generally determined before he is thirteen years old. If he is to be an artisan, he goes to a trade school, if he is to be a merchant, a soldier, a government officer, a literary man, or a gentleman of leisure, he is taught accordingly. One set of schools was regarded as special as another. At no one school were all classes supposed to attend.

In nearly every instance throughout Europe, the trade schools received government aid. The paternal character of the governments which deliberately encouraged such industries as were peculiar to a people made this entirely consistent. For the most part, corporations or firms managed the schools, and furnished what additional means they needed.

The Russian schools of St. Petersburg and Moscow, I did not visit; but a friend of mine<sup>1</sup> spent the summer of 1886 in Russia, and I have his full report of the nature and scope of their technical schools. They are strictly professional in character, intended to produce mechanical engineers for the government service.

Their method of tool-instruction is most admirable, and, to a certain extent, is worthy of the widest imitation. Their course

---

<sup>1</sup> William Mather, Esq., of Manchester, Eng. His report of the schools of Russia, published as a part of the report of the Royal Commission, is the fullest account of Russian schools which has yet appeared.



of training is six years, and naturally shop-work is the most important feature. During the first three years the students are in the "instruction-shops." Systematic and logical exercises are used, and the method of class instruction by laboratory lectures is followed. This preliminary training during the first three years is broad in its character and generous in its scope. The last three years are spent in construction-shops on heavy, commercial work. It is obvious that the only part which can belong in a general educational institution is the first half.

Just at the stage when the Russian student enters the construction-shop to put in practice the principles and methods he has mastered, the American student leaves the educational institution altogether, and betakes himself to an establishment for special training, mechanical or otherwise. Elsewhere I have been happy to acknowledge my indebtedness to the Russians for their admirable method.

Of the Slöjd (*sloid*) schools of Sweden, I know only by reports. They have been fully written up by Prof. Ordway, and more recently they have been under discussion in England. However well they may suit the wants and constitution of Swedish society, I am sure that *sloid* will never flourish on American soil.

It must suffice if I mention three chief objections to the system:—

1. The manual training involved is limited to wood-work.
2. The pupils are taught and shown about their work separately, individually; i.e., class-instruction is not given, and the several pupils in the laboratory are doing very different things.
3. The things wrought are household furniture, or implements and utensils to be carried home and used there. There appears to be no aim beyond making thrifty householders.

In spite of the vast amount that has been said about the manual instruction in Europe, and in spite of the great benefits the trade schools have brought to their industries, and in spite of the greatly improved grade of workmen their schools have produced,—I found no system of public instruction which would bear transportation to the United States of America.

Their schools have many excellent features, and their appropriations for schools are most ample; but their long daily sessions, their long terms, and the conventional nature of their curricula unfit them, without great modifications, for use here. Their manual training is generally very narrow, and has for its object not mental and moral growth, but the acquisition of practical skill for subsequent definite use.

Unless I am greatly in the wrong, our American idea of manual training as a feature of general education, not for a trade or a profession, but for the healthy growth and vigor of all the faculties, for general robustness of life and character, is far in advance of any model in a foreign land. I am not of those who think it indicative of fine breeding to decry American institutions, and laud extravagantly those of distant countries which will not bear transplanting.

The manifest inferiority of schools when actually visited, and compared with their world-wide reputations, is almost painful. The only school of a manual character I visited in Europe which surpassed my expectations was the French government school at Chalons; with all others I was disappointed.

## CHAPTER XV.

## PLANS, SHOP DISCIPLINE, TEACHERS, REPORTS, ETC.

AS to plans, a great variety could be given, adapted to various conditions. As a rule, existing buildings have been utilized for shops, and in but few cases have complete buildings been erected. The shops for technical schools are generally unsuited to a manual training school. They are either too small or too large, and they lack that uniformity of equipment which a section of from twenty to twenty-four pupils requires.

Even in the case of the erection of a new building, local conditions are likely to influence the plan. The St. Louis and the Chicago manual training schools were organized complete in buildings designed and built for the purpose, and all the appointments for a boys' school were included. The Scott Manual Training School of Toledo comprises only shops, laboratories, and drawing rooms, the study and recitation rooms being furnished by the city high school. The same is true of the Cleveland and Denver manual training schools. Of the Tulane High School of New Orleans, I have no details. In a great majority of cases where shops have been attached to existing schools, unused rooms, too often in the basement, have been utilized. The purpose of this chapter is to make suggestions of value, first, when a complete manual training school is to be provided for; and, secondly, when only the shops and drawing rooms are to be added to an existing school.

Altho the building of the St. Louis Manual Training School was erected partly in 1879 and partly in 1882, and there was little to guide us in arranging the details, the plan is an admirable one in most respects. Some of its deficiencies I shall

point out. Fig. 135 gives the plan of the third story. With the exception of one drawing division and one wood-working division, all the work of the youngest class is done on this floor. The drawing room is furnished with twenty-four stands, and each recitation room with twenty-four shelf-chairs.

*S* is the wood-working room, with twenty-four benches and twenty-four lathes, four of which are not shown. The scale of the engraving is about twenty-one feet to the inch.

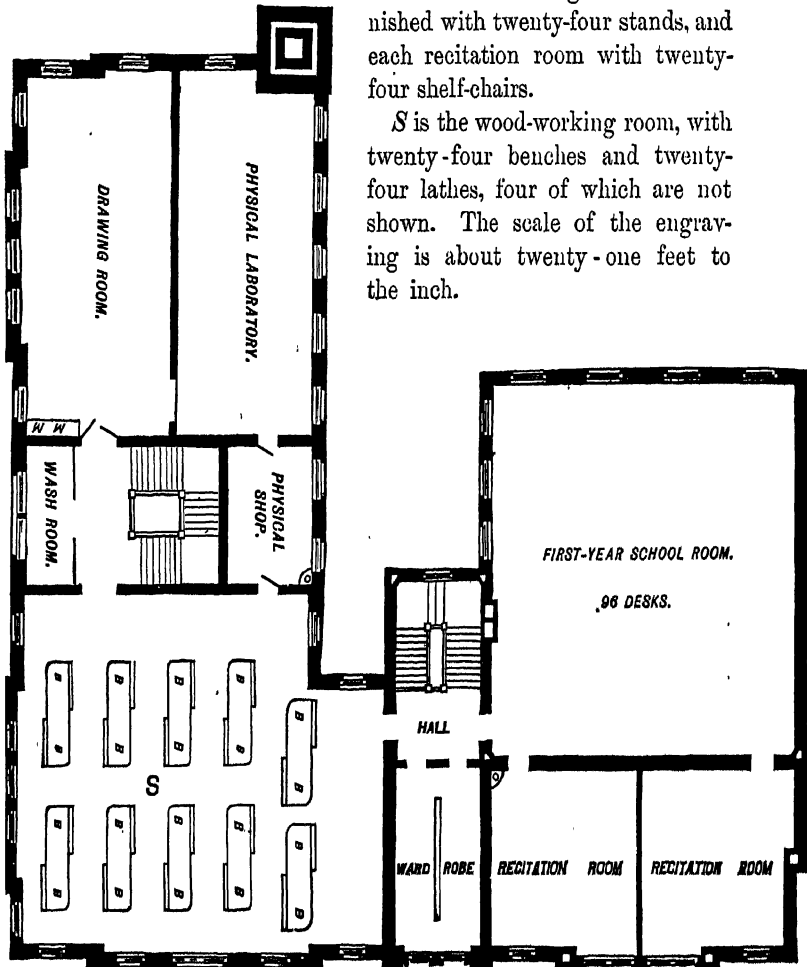

FIG. 135. ST. LOUIS MANUAL TRAINING SCHOOL.—PLAN OF THIRD STORY.

The physical shop and laboratory are full of apparatus and tools for making more physical apparatus. These two rooms are used by the several divisions of the second-year class.

Fig. 136 gives the plan of the second story. The middle class may have four divisions of twenty-two each. Their work takes them to all the floors.

It will be observed that the wood-working room with lathes is directly under the drawing room and laboratory of the third story. This arrangement I criticise on the next page.

The divisions which go to the forging-shop, which is shown in the next cut, generally pass through the corner of the yard.

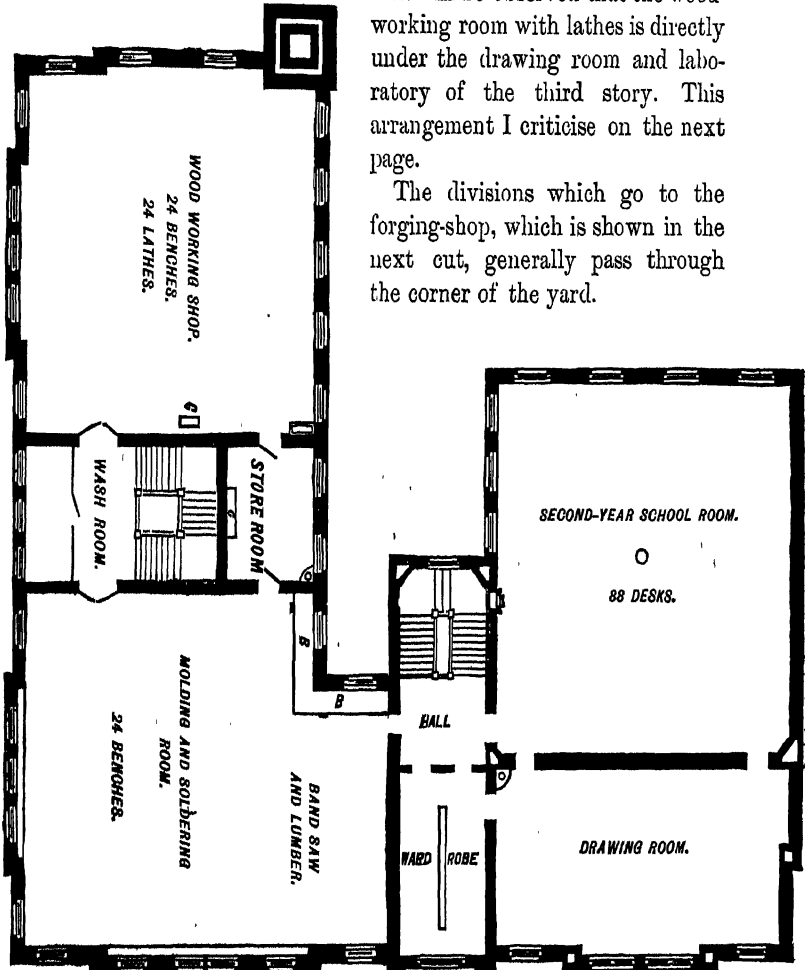

FIG. 136. ST. LOUIS MANUAL TRAINING SCHOOL.—PLAN OF SECOND STORY.

The walls of the various shops are generally of plain brick-work, which is whitewashed if there is any lack of light. Ceiling under the joice is unnecessary if the flooring is double.

Fig. 137 gives the plan of the first story, which is mainly for the use of the highest grade, or third-year class. With the exception of the drawing, this class does all its work on this floor.

The benches, *B B*, are shown in the engraving, as are also the dressing lockers, *C*.

The lathes, drills, and other machine tools stand compactly arranged across the room. In the forging shop there are twenty-two anvils and forges.

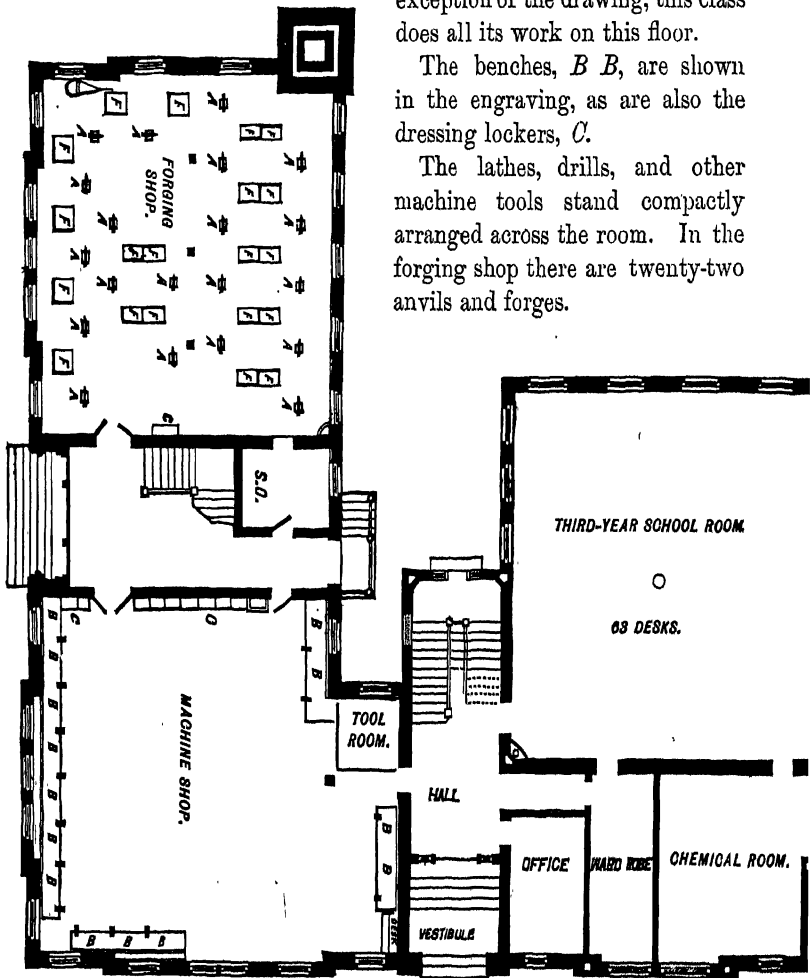

FIG. 137. ST. LOUIS MANUAL TRAINING SCHOOL.—PLAN OF FIRST STORY.

The basement has, on the one side, the wash-rooms and dressing-rooms for the first-floor shops, the engine, and the engineer's repair-shop; on the other side, the water-closets, etc., a play-room, a lunch-room, and the warm-air chamber. In a

fireproof room under the side steps is the oil-room. There is no basement to the forging-shop. The boiler is set in a separate building as a part of the university battery. As a rule, I would put the boiler in a special building near the base of the stack.

There are three respects wherein these plans could be improved, which I feel it my duty to point out.

1. The forging-shop, which is the noisiest shop in all, is rather too near the schoolrooms. In warm weather, when the windows are open, the noise is somewhat troublesome. I should prefer a plan which turned the shop wing ninety degrees to the left, so as to place the forging-shop directly beyond the machine-shop. In other words, I would put the school and drawing rooms at the head of a T, and the shops in the long central part, with the forging-shops at the extreme end.

2. There is no well or shaft for the transmission of power to the several floors from the basement. The transmission should be from floor to floor by belts with suitable tighteners. Each shop should be furnished with a clutch, by means of which the teacher in charge may turn on his shop, or turn it off, at pleasure, without interfering with the other shops. At times the teacher needs a quiet room where his voice may be easily heard, as he gives the theory of a machine, explains the details of a process, or criticises work before a class. In the transfer of power, gearing is too noisy for a school. The main shafting and pulleys of the machine-shop of the St. Louis school can not be stopped without stopping the engine. While this defect is hard to remedy, it may easily be avoided in a new plan.

3. On the third floor, I would interchange the wood-working shop with the drawing and physics rooms. This would accomplish two things: *first*, it would place the drawing room and physical laboratory over a comparatively quiet room, as there is no noise in the molding room; and, *secondly*, no divisions would pass through a shop where the boys are at work.

These criticisms may appear to be trifling and uncalled for, but they have force enough to serve others whose plans are yet to be drawn. I am not criticising another: I alone am responsible, and I have already given those who have followed us the benefit of these suggestions.

As a rule, the study and recitation rooms should be separated from the shops by two walls enclosing halls, stairways, or yard; at the same time I should prefer to have all the rooms for a class on the same floor, or as nearly so as possible, and but a few steps away. It may not work badly to have a division cross the yard, but I advise strongly against sending a division out of the yard, or across the street. I do not favor the transfer of a division of students from one principal to another, and back again. No principal would like that arrangement in the case of such a study as arithmetic or spelling, and shop-work and drawing should be treated with precisely the same consideration. The same precautions should in all cases be taken to prevent irregularities and loss of time. In short, manual work should be treated as school work, and watched, and guarded, and sustained as such. Until such treatment is possible, it would be better to go without it.<sup>1</sup>

In cases where manual work is added to an existing school, the erection of a new building is generally necessary; but this should be so planned as to preserve the unity of the arrangement, and let the principal remain principal of the whole institution. I take great pleasure in giving the details of a plan of such an addition to a large city high school, which I regard as in every way most admirable, and worthy of the widest following. I refer to the

#### HIGH AND MANUAL TRAINING SCHOOL OF TOLEDO, OHIO.

The addition is known as the Scott Manual Training School, for the reason that the additional building was erected and equipped; and its running expenses provided for, by an institution known as the "Toledo University," originally endowed by Jesup W. and Susan Scott in 1872.<sup>2</sup>

---

<sup>1</sup> "The workshop should not be put into the cellar, nor supplied with bad tools, as tho anything or anywhere would do for it; but it should be dignified by giving it as good a room as is chosen for any other subject of the school course, and the tools and appliances should be as complete as the funds of the school will permit." — PROF. RIPPER.

<sup>2</sup> The endowment was subsequently increased by the sons of Mr. Scott, William H., Frank J., and Maurice A. Scott, in 1874; and the entire trust was conveyed to the city in 1884. The only work thus far undertaken by the University has been the establishment of the Manual Training School. The Board of



The building was erected in 1885, and formally opened in December of that year. Meanwhile, considerable manual work had been done in the rooms of the high school. Fig. 3, page 13, gives a cut of the addition. It is seen to consist of four stories, including the well-lighted rooms on the ground floor. For the sake of showing the arrangement of rooms, including wash and tool rooms, the ample provision for light in every shop, the comparative isolation of the forging-shop from rooms likely to be disturbed by noise, and the numerous connections with the old building, I give the floor plans in full. Power is communicated to the upper floors through the hall-way. The only detail that would be improved by change, so far as I have heard, is the shallowness of the projection which includes the entrance. Had this projection been five or six feet more than it is, the office, library, and upper halls would have been greatly improved by their gain in size.

Fig. 138 gives the ground floor plan. The boiler-house is under ground and beyond the wall on the right, by the arrow which shows the descending steps.

The large shops are each forty by fifty-five feet. The size of the other rooms may be determined by scale.

In the plan of the first story (Fig. 139) the wood-working shop is furnished with lathes as well as benches, while on the next floor (Fig. 140) only benches are shown. In Fig. 141, which gives the details of the third story, the broken lines indicate the skylights, which supplement the short windows in the walls.

The great distinguishing feature of the Toledo school is its provision for giving manual training to girls. Girls in divisions by themselves are not only taught all the drawing that the boys have, but light wood-work (including wood-carving), cooking (as an illustration of applied chemistry), needlework, cutting, and fitting (as applications of mechanical drawing).

---

Directors, as now organized, consists of the mayor, six members nominated by him, and six nominated by the Board of Education; all are to be confirmed by the Common Council of Toledo. William H. Scott is the president, and A. E. Macomber, secretary.

This union of forces in the cause of education exhibits the high importance of enlightened liberality and public spirit in the managers of public trusts, and I do not hesitate to commend their action to the friends of education in all communities.

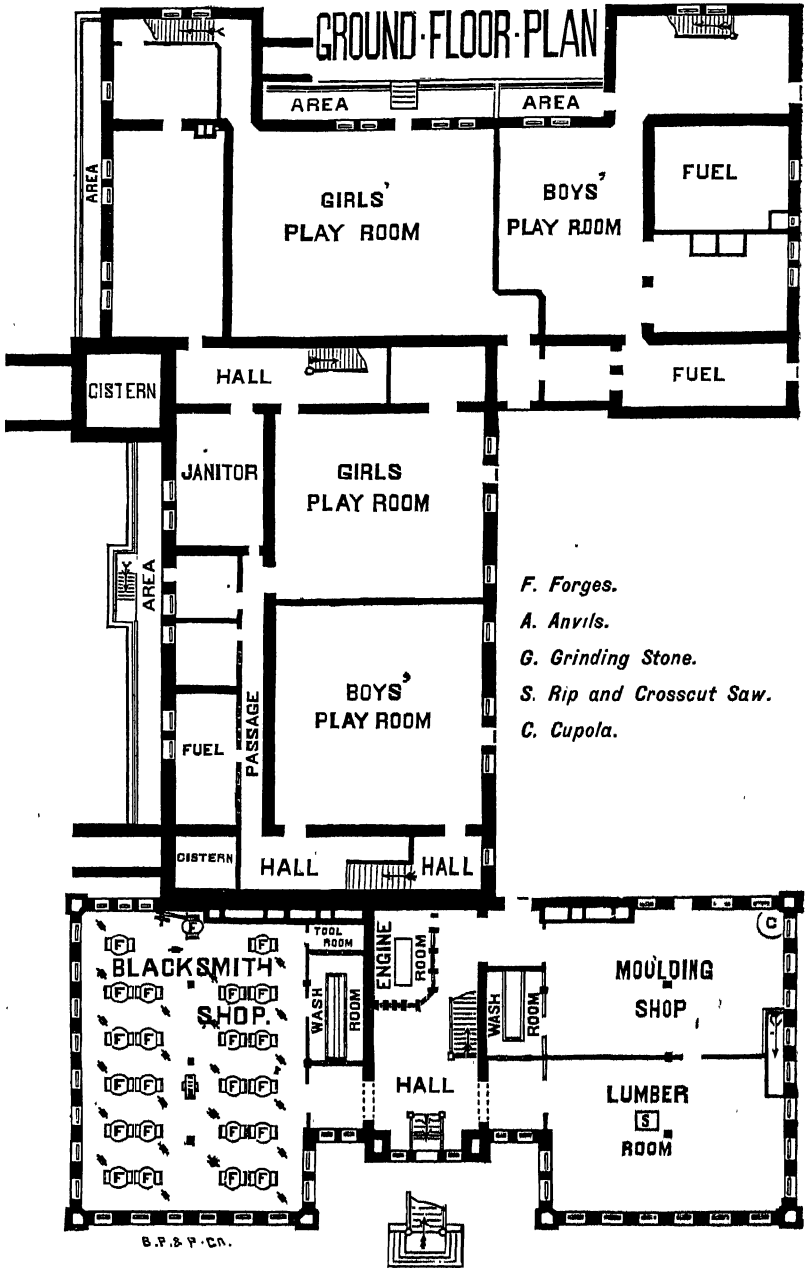

Fig. 138. TOLEDO HIGH AND MANUAL TRAINING SCHOOL.

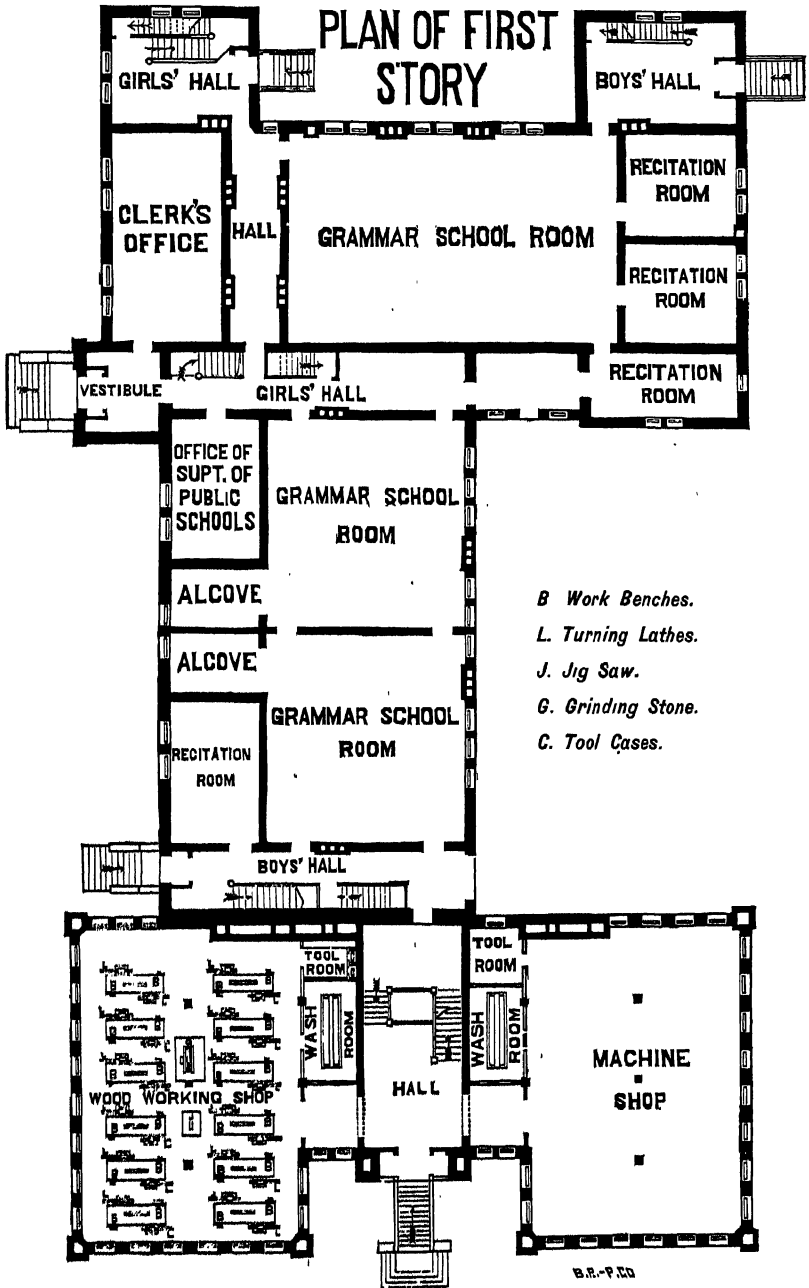

FIG. 139. TOLEDO HIGH AND MANUAL TRAINING SCHOOL.

The cooking-room, on the third floor in Fig. 141, is thus described in the last catalog of the school:—

“This is forty by twenty-seven feet, with one large Garland range, two gas cooking-stoves, and five double tables five feet long by five feet wide, each table accommodating four pupils. Each girl has her own table space for work, and there is a small gas-stove for every two pupils. Each table space has a drawer and cupboard below it for all essential utensils, and each pupil must personally go through every process taught. At the other end of the room are pantry closets for the teacher’s use, and a commodious wash-room, with all the conveniences for girls, including individual closets for the keeping of aprons, clothes, etc.”

In another respect the Toledo school has led the way; viz., in giving to boys of the senior grammar grade substantially the shop-work and drawing I have given in Chap. II. as appropriate for our first year. The result of their experience thus far appears to show that the work is not too difficult for them, tho it was found necessary to give less time in the shop. I hope the experiment will be continued at Toledo and elsewhere, and always under judicious supervision. A very young child may be made to go through certain motions, just as he may be taught to repeat words in an unknown tongue, and yet completely fail to make any rational progress thereby. There is, of course, a manual training suited in quality and quantity for the pupils of each of the lower grades; the important thing is to find it. This is true for girls as well as for boys. I give in an Appendix the course of study for girls in the Toledo school.

The cost of the addition to the Toledo High School, “including the underground boiler and coal-rooms placed outside the main building, sewer connections, grading, walks, steam-piping,” etc., is given as \$22,951.44.

#### SHOP DISCIPLINE.

I know that many teachers will at first be greatly in doubt as to what they ought to ask, and what they may reasonably expect, of pupils during shop hours in the matter of discipline. Of course the standard should be different from that in a study or recitation room. The legitimate noise of a shop is not demoralizing, and the teacher ought not to make it a point to

reduce the noise to a minimum. The main object is to secure intellectual and manual activity on the subject legitimately in hand. Close attention to business should be insisted on. All trifling and irrelevant matters should be excluded; but it is not at all necessary to forbid a boy who is in doubt from asking a neighbor what to do, or from watching for a moment his method of procedure. Such assistance is very stimulating, and may be valuable to both parties. The teacher, who is supposed to know all that is going on in his room, is the proper one to give aid; but he will often send one boy to another for the purpose of calling attention to some superior work, or of emphasizing a point by requiring one boy to explain it to another. Good work should be freely passed around and inspected.

At the end of a shop exercise, it is a good plan to allow the utmost freedom of communication. This may last two or three minutes. No boy can be deeply interested in his work, and not have a burning, almost an overmastering, desire to talk about it to his fellows. To recognize this natural and healthy appetite, and thus to reasonably control it, is certainly judicious. When a boy knows that he is soon to have an opportunity to speak his mind to his neighbor, he is easily persuaded to wait till the appointed time comes.

A small gong should be used in each shop for signaling a class: when to break ranks and go to work, when to assemble at the teacher's bench, when to "clean up," when to file out of the room, etc. Each division before leaving the shop should brush off the benches, machine tools, and other appliances in use, restore all tools to their places, and put all in order for the next division. This takes but two or three minutes, and it encourages the formation of a habit of order. The floor should be cleaned every night by the janitor.

Forge and metal work is impossible without soiled hands and faces; and the students should be encouraged to remove all their linen, and to put on blouses which shall thoroughly protect their underwear. A good wash in warm water with plenty of soap, followed by the use of a clean, dry towel, will bring the young workmen back to the schoolroom none the worse for their physical contact with the entities of the shop.



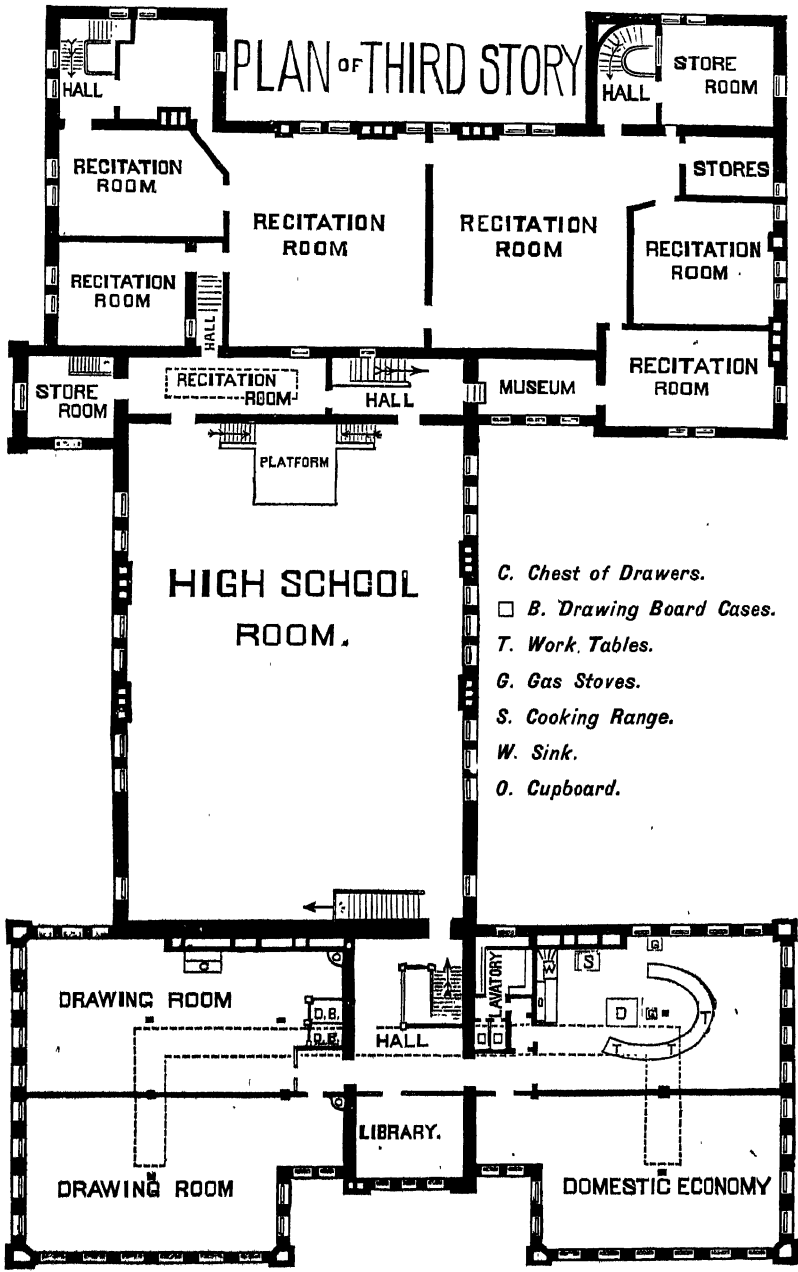

FIG. 141. TOLEDO HIGH AND MANUAL TRAINING SCHOOL.

Of course it is readily seen that each student must have his separate locker, in which his valuables (sleeve-buttons, studs, watch, etc.) may be left secure: not even a manual training school is proof against a thief or a boy with a mania for pilfering.

#### REPORTS.

The work of the shop should be reported on as regularly as that in any branch of study; and occasionally written examinations should be held on shop-work for the purpose of testing the pupils' ability to use correctly names and technical terms, and to describe processes logically. As in literature, science, and art, there are many things that are arbitrary and conventional, and they must be so learned as to be correctly used. A half-quarterly report should show one's degree of success in each branch of work and study, and a boy should be made to feel that no amount of success in one direction can adequately atone for poor work in another. It is perfectly natural for a boy to *enjoy* some kinds of work more than other kinds, and to succeed in one line more readily and more fully than in another; but all may easily see the propriety of equal fidelity to every demand of the program. The freedom of choice which may be entirely proper at a later stage, when the course of the school is finished, is altogether out of place in a school one of whose chief purposes is to determine by a broad and liberal training what one's special aptitudes really are. Mere fancy, born of accident and unequal acquaintance, must not be regarded as evidence of innate capacity.

#### TEACHERS.

Good teachers are, of course, the most valuable part of a school's outfit; in this respect, the manual training school is not singular. The broader his training and culture, the better the teacher, in the shop as well as elsewhere. Above all, the shop teacher should know fairly well the whole course of the school, particularly in drawing and shop-work. Every teacher should be able to take the point of view of those whom he teaches, and to enter into hearty sympathy with them, — to see with their eyes, to judge from their limited experiences, to



see beforehand just the mistakes they will make, and the difficulties they must meet and overcome. Admit no narrowness to the shop. While recognizing the manliness of intelligent skill in every field, do not allow any unworthy tricks of a trade to degrade the tone of the school.

At present, good shop teachers are scarce. As a rule, the reputed fine workmen of twenty years' experience, who learned their trade in the old-fashioned way, are quite unsuited to a manual training school. They find it impossible to adopt our methods, and to appreciate our aims. Unless a boy expects to be a blacksmith, they can not understand why he should care to learn the principles of forging; and what can be the object of tool-work of any sort, except to make something of use?

For a teacher, give me first a graduate of a manual training school, who has subsequently taken a more advanced course in polytechnic or college work. If such can not be had, give me a young teacher who has had a few terms at a manual institute, and who has caught the *spirit* while acquiring the *art* of manual training. Do not underrate the position, and give the teacher less credit or less pay than those in the other departments. It will be found that a high order of intelligence and skill in more than one field is needed for a successful shop teacher.<sup>1</sup>

The most essential thing, perhaps, is the divine faculty of teaching. The ability to do work one's self is no evidence of one's ability to teach it. He must have a logical, analytic mind; and he must be able to subdivide the steps of progress, so as to bring the separate intervals of advance just inside the capacity of his class. The demands of the hour must be seen to be reasonable, requiring vigorous effort, but not exceeding one's strength. The teacher is not to carry his pupils: he is only to show them where and how to climb.

But this is the old, old story. If teaching is a science, its methods are such as can be understood with thoughtful study; and the substance of what I would say is, that manual educa-

---

<sup>1</sup> "The teacher must be a man whose heart is in his work, and one who will create interest and enthusiasm among the pupils; accordingly he must not be the laziest intelligent, or the worst paid member of the staff. Better no workshop at all, than a cold, half-hearted instructor." — PROF. RIPPER.

tion and manual teachers should be rated and secured as other educations and other teachers are rated and secured.

#### COST OF MATERIALS.

Five dollars a year will about cover the cost of materials and repair per pupil in a wood-working shop. In metal work, the expense is greater, — say, eight dollars per pupil, — particularly if specimens are preserved or given away. Projects are expensive, unless the students furnish their own material. In the latter case it may be well to have it understood that the articles are to be the property of the makers as soon as the year's exhibit is over. If the school has permanent use for such articles, it should pay for the materials. This remark should refer to the drawing as well as to the shop-work.

#### LUNCH.

The long active day of the manual training school should not be allowed to pass without a substantial lunch. This should be something more than an apple or an orange. Bread and meat, soup, milk, coffee, pastry, and fruit, should furnish a good meal.

Thirty minutes are sufficient for a lunch at the building; and, where lunch is so taken, the afternoon session may close at half past three, instead of at four o'clock.<sup>1</sup>

There are many other matters of greater or less importance to a school for boys who are just upon the threshold of manhood, which my readers must take for granted. Music, debates, declamations, etc., *in reason* are as appropriate here as anywhere, and nothing need be said about them; but, like all other good things, they should not be allowed to crowd out other things equally and perhaps more valuable. As I have said elsewhere, there are many avenues to culture; keep them all open.

---

<sup>1</sup> This is the case at the St. Louis Manual Training School. A caterer sets a table in the lunch-room at one o'clock. Ten cents will buy a fair meal. The greater proportion of the students bring at least a part of their lunch from home, which they eat with the others at the lunch-table.

## APPENDIX I.

---

### ST. LOUIS MANUAL TRAINING SCHOOL COURSE OF STUDY.

---

#### FIRST-YEAR CLASS.

*Arithmetic* completed. *Algebra*, to equations.  
*English language*, its structure and use. Study of selected pieces. *History* of the United States.  
*Latin grammar and reader* may be taken in place of English and history.  
*Hurley's Introduction to Science*. *Physical geography*. *Botany*.  
*Drawing*, mechanical and free-hand. *Penmanship*.  
*Carpentry and joinery*. *Wood-carving*. *Wood-turning*.

#### SECOND-YEAR CLASS.

*Algebra*, through quadratics. *Geometry* begun.  
*Natural philosophy*. Experimental work in the physical laboratory. Principles of mechanics.  
*English composition and literature*. *Rhetoric*. *English history*.  
*Latin* (Caesar) may be taken in place of rhetoric and history.  
*Drawing*. — Line-shading and tinting, machines. Development of surfaces, free-hand detail drawing. Isometric projections.  
*Forging*. — Drawing, upsetting, bending, punching, welding, tempering; pattern-making, molding, soldering.

#### THIRD-YEAR CLASS.

*Geometry* continued. *Plane trigonometry, mensuration*.  
*English composition and literature*. *History*. *Elementary political economy*.  
*French* or *German* may be taken in place of English and history, or in place of the science study.  
*Physiology*. *Elements of chemistry*. *Book-keeping*. Students who have taken Latin, and who intend to enter the Polytechnic School after completing the course in this School, will take history in place of physiology, chemistry, and book-keeping.  
*Drawing*. — Brush-shading, shadows, geometrical problems, architecture, machines.  
*Work in the machine-shop*. — Bench-work and fitting, turning, drilling, planing, screw-cutting, etc. Study of the steam-engine.

## APPENDIX II.

## THE TOLEDO MANUAL TRAINING SCHOOL.

From the last catalog I cut the following:—

## COURSE OF COMBINED STUDY AND TRAINING FOR GIRLS.

## DOMESTIC ECONOMY DEPARTMENT.

## FIRST YEAR.

- |   |   |                               |
|---|---|-------------------------------|
| (1.) <i>Mathematics.</i> — Arithmetic.  | } | Senior<br>Grammar<br>School.  |
| (2.) <i>Science.</i> — Physical geography.  |   |                               |
| (3.) <i>Language.</i> — Grammar, spelling, writing, English composition.              |   |                               |
| (4.) <i>Drawing.</i> — Free hand and mechanical, lettering.                           | } | Manual<br>Training<br>School. |
| (5.) <i>Domestic Economy.</i> — Light carpentry, wood-carving, care and use of tools. |   |                               |

## SECOND YEAR.

- |  |   |                               |
|--|---|-------------------------------|
| (1.) <i>Mathematics.</i> — Algebra, arithmetic.  | } | Junior<br>High<br>School.     |
| (2.) <i>Science.</i> — Physiology and botany.  |   |                               |
| (3.) <i>Language.</i> — Grammar, rhetoric, writing.  |   |                               |
| (4.) <i>Drawing.</i> — Free-hand and mechanical. Designs for wood-carving.   | } | Manual<br>Training<br>School. |
| (5.) <i>Domestic Economy.</i> — Clay-modeling, wood-turning; introduction to course in cooking, or garment cutting and making. |   |                               |

## THIRD YEAR.

- |  |                                 |                           |
|--|---------------------------------|---------------------------|
| (1.) <i>Mathematics.</i> — Geometry, arithmetic reviewed.  | }                               | Middle<br>High<br>School. |
| (2.) <i>Science.</i> — Physics.  |                                 |                           |
| (3.) <i>Language.</i> — English composition, history.  |                                 |                           |
| (4.) <i>Drawing.</i> — Free-hand and architectural, designing from plant and leaf forms.   |                                 |                           |
| (5.) <i>Domestic Economy.</i> — Instruction in preparing and cooking food, purchasing household supplies, care of the sick, etc. | } Manual<br>Training<br>School. |                           |

## FOURTH YEAR.

- |  |   |                               |
|--|---|-------------------------------|
| (1.) <i>Mathematics.</i> — Plane trigonometry, mechanics.  | } | Senior<br>High<br>School.     |
| (2.) <i>Science.</i> — Chemistry, book-keeping, ethics; rights and duties, laws of right conduct.                  |   |                               |
| (3.) <i>Language.</i> — Political economy, English literature and composition.                                     |   |                               |
| (4.) <i>Drawing.</i> — Machine and architectural details, decorative designing.                                    | } | Manual<br>Training<br>School. |
| (5.) <i>Domestic Economy.</i> — Cutting, making, and fitting of garments, household decorations, typewriting, etc. |   |                               |

"The above course in Domestic Economy is arranged with special reference to giving young women such a liberal and practical education as will inspire them with a belief in the dignity and nobleness of an earnest womanhood, and incite them to a faithful performance of the every-day duties of life; it is based upon the assumption that a pleasant home is an essential element of broad culture, and one of the surest safeguards of morality and virtue.

"The design of this course is to furnish thorough instructions in applied housekeeping, and the sciences relating thereto; and students will receive practical drill in all branches of housework, in the purchase and care of family supplies, and in general household management, but will not be expected to perform more labor than is actually necessary for the desired instruction.

"In cookery, practical instructions will be given in the means employed in **BOILING, BROILING, BAKING, FRYING, and MIXING**, as follows:—

"**BOILING.**—Practical illustrations of boiling and steaming, and treatment of vegetables, meats, fish, and cereals, soup-making, etc.

"**BROILING.**—Lessons and practice in: meat, chicken, fish, oysters, etc.

"**BREAD-MAKING.**—Chemical and mechanical action of materials used. Manipulations in bread-making in its various departments. Yeasts, and their substitutes.

"**BAKING.**—Heat in its action on different materials in the process of baking. Practical experiments in baking bread, pastry, puddings, cake, meats, fish, etc.

"**FRYING.**—Chemical and mechanical principles involved and illustrated in the frying of vegetables, meats, fish, oysters, etc.

"**MIXING.**—The art of making combinations, as in soups, salads, puddings, pies, cakes, sauces, dressings, flavorings, condiments, etc.

"**MARKETING AND ECONOMY, ETC.**—The selection and purchase of household supplies. General instructions in systematizing and economizing household work and expenses. The anatomy of animals used as food, and how to choose and use the several parts. Lessons on the qualities of water and steam; the construction of stoves and ranges; the properties of different fuels.

"**THE TEXTILE FABRIC WORK** will cover instructions in garment cutting and making; the economical and tasteful use of materials; millinery, etc."

## APPENDIX III.

## DAILY PROGRAM. -- TOLEDO MANUAL TRAINING AND HIGH SCHOOL.

CLASSES.	8.15-9.	9.15-10.	10-10.45.	10.45-11.30.	11.30-12.15.	Noon Recess.			12.45-1.30.	1.30-2.15.	2.15-3.	3-3.45.
8d Year.	Drawing.	High School.	High School.	High School.				Drawing.	High School.	High School.	90 m. Shop-work.	
2d Year, Boys.		High School.	High School.	High School.				Drawing.	High School.	High School.	90 m. Shop-work.	
2d Year, Girls.		Drawing.	High School.	High School.	90 m. Domestic Economy.				High School.	High School.	High School.	High School.
2d Year, Girls.		High School.	High School.	Drawing.					High School.	High School.	90 m. Domestic Economy.	
1st Year, Boys.		Grammar School.	Grammar School.	90 m. Shop work.					Grammar School.	Grammar School.	Grammar School.	Drawing.
1st Year, Boys.		90 m. Shop-Work.		Grammar School.				Drawing.	Grammar School.	Grammar School.	Grammar School.	Grammar School.
1st Year, Girls.		30 m. Study.	60 m. Shop-work.	Grammar School.	Drawing.				Grammar School.	Grammar School.	Grammar School.	Grammar School.
1st Year, Girls.		Grammar School.	Grammar School.	60 m. Shop-work.					Drawing.	Grammar School.	Grammar School.	Grammar School.

## APPENDIX IV

## MANUAL TRAINING IN THE HIGH SCHOOL.

[From the address of Gen. Francis A. Walker, president of the Massachusetts Institute of Technology, at the Chicago meeting of the National Educational Association in July, 1887.]

WHATEVER other arts may, in the development of this system, come to be associated with carpentry and wood-turning in the grammar schools, it appears to me, that, at the very beginning, we may demand a complete course of both wood and metal working for that smaller number of advanced pupils who go forward into the high school. If it is for the interest of the State that these young persons shall, at the public expense, be further educated and cultivated on one side of their minds, it is not equally, but doubly, desirable that the education and cultivation of their other powers and faculties should be kept up in the high school. It is little less than a shame that we should graduate from these schools pupils who are highly accomplished in language, composition, and declamation, but are less keen in perception, less careful in observation, weaker in practical judgment, with less of visual accuracy, less of manual dexterity, less of the executive faculty, — the power, that is, of doing things instead of merely thinking about them, talking about them, and writing about them, — than the children of the ordinary ungraded district school.

Whatever views one may hold of the mutual relations of the child and the State in the grammar school, it can be gainsaid by no one, that, if the community is to be called upon to carry the more favored children forward through long and expensive courses of advanced education and training, those who, on behalf of the community, direct the schools of this class, have the absolute right to impose whatever terms and conditions, to exact and to withhold whatever the public interest may require. Cherishing the views I do as to what constitutes a complete education, I would allow no pupil to graduate from a high school who was not as proficient and exact in mechanical as in grammatical exercises. I would not make myself responsible for adding to the number of youth who have been trained in description, without having been taught to observe the things they should describe; who have

spent years in the art of rhetorical elaboration and ornamentation, without acquiring any adequate body and substance upon which to exercise those arts; who are clever in dialectics and declamation, but purblind in perception, and feeble in execution; great at second-hand knowledge, but confused and diffident when thrown upon their own resources; skillful with the pen, but using any other tool awkwardly and ignorantly.

The mischief we can possibly do, through a one-sided education, to those who stop short with the grammar school, is fortunately limited. These children, escaping from tuition before they have got their growth, and going at once to work, have an opportunity to cure in part the faults, and supply in part the deficiencies, of their education. That work, of course, does them far less good, and they do it far less well, than if the foundation had been laid in early youth, under proper guidance and instruction. Yet, at least, they are saved from growing up, and growing out, all on one side, like the unhappy youth who are destined to go on, for three or seven years more, rehearsing the opinions of others; memorizing facts ascertained by others; practicing a simulated passion in declamation and an artificial taste in composition, making much of grammatical niceties, painfully polishing periods without much regard to the thoughts these should enclose, going over and over a weary round of second-hand information and second-hand ideas, and acquiring a few purely conventional accomplishments.

We hear much of the vulgar contempt of so-called self-made men towards scholars; of their distrust, in practical matters, of school-made and book-read men. Doubtless some part of this feeling is of vulgar origin, due to jealous envy or ignorance; but a far larger part I believe to be perfectly just, arising from a correct apprehension of the natural effects of long-continued study and exercise within the traditional lines of high-school and college instruction, producing a disposition to hesitate, to procrastinate, to multiply distinctions, to refine in preparation, to stand shivering on the verge of action. Doubtless many school and college-bred men, when thrown into action, are found to have enough of robust manhood to overcome the ill effects of their early training, especially if in school or college they were not very good scholars; but would it not be better from the first to associate with the dialectical, grammatical, and rhetorical exercises of our schools, and with the perhaps necessary acquisition of much mere gazetteer, cyclopaedic, and dictionary information, studies and exercises which shall not only prevent the formation of distinctly bad habits of mind and will, but shall positively develop those powers and faculties which the very first access to the duties of professional and business life shows to be the most useful of our endowments?

For one, I believe that the introduction of the new studies and exercises which we are advocating will not prove a mere addition to the work of the school or college. I believe it will also profoundly modify the instruction given within traditional lines. Boys and young men who have learned to observe for themselves, to acquire knowledge at first hand, to give effect to their purposes, and a form to their ideas; who have been accustomed to



impose their will upon matter, and to make it take shape to suit their intellectual conceptions; who know how to project, to plan, to execute, — will have little patience with much that makes up the traditional curriculum. They will demand to be brought face to face with facts. They will insist upon going to the bottom of any matter they have to deal with. That genuine intellectual honesty which is the first-fruit of the objective study of concrete things will make them scorn to defend, in dialectical and rhetorical practice, theses which they do not thoroughly believe. They will grudge every hour spent in memorizing matter for which they can at any time resort to the gazetteer or cyclopædia. It will be hard to impose on such students with sounding names, deceive them with sophistries, or bear them down by authority. They will care much for principles, little for the manner in which these may be dressed up for effect, or tricked out for public admiration.

## APPENDIX V.

## MANUAL TRAINING IN SCHOOL EDUCATION.

BY SIR PHILIP MAGNUS

By manual training one commonly means exercises in the use of the tools employed in working wood and iron

It can not be too often repeated that the object of workshop practice, as a part of general education, is not to teach a boy a trade, but to develop his faculties, and to give him manual skill; that, although the carpenter's bench and the turner's lathe are employed as instruments of such training, the object of the instruction is not to create carpenters or joiners, but to familiarize the pupil with the properties of such common substances as wood and iron, to teach the hand and eye to work in unison, to accustom the pupil to exact measurements, and to enable him by the use of tools to produce actual things from drawings that represent them . . . To assume that the best education can be given through the medium of books only, and can not be equally obtained from the study of things, is a survival of the mediævalism against which nearly all modern authorities protest.

But there is another and more deeply rooted error in this argument. People often talk and write as if school-time should be utilized for teaching those things which a child is not likely to care to learn in after-life, whereas the real aim of school education should be to prepare, as far as possible, for the whole work of life. . . . The endeavor of all educators should be, to establish such a relation between school instruction and the occupations of life as to prevent any break of continuity in passing from one to the other. The methods by which we gain information and experience in the busy world should be identical with those adopted in schools.

It is because the opposite theory has so long prevailed, that our school-training has proved so inadequate a preparation for the real work of life.

The demand for technical instruction, both in our elementary and in our secondary schools, is a protest against the contrast which has so long existed between the subjects and methods of school-teaching and the practical work of every-day life.

We are always justly complaining that in this country children leave school at too young an age, before they can have had time to properly assimilate the knowledge they have acquired, with the result that they soon forget a great part of the little they have learned. At the age of fifteen or sixteen they begin to feel the want of technical instruction. There can be little doubt, if elementary education were made more practical, that parents would be more willing, even at some sacrifice, to let their children benefit by it. They are often led to take their children away from school, because they do not see much use in the "schooling." Of course, the desire to secure the child's early earnings operates in very many cases; but I am convinced that it would be easier to persuade parents to forego these earnings, if the school-teaching had more direct reference to the work in which the children are likely to be subsequently occupied.

. . . . .

A workshop has recently been fitted in the school attached to St. Jude's Church, Whitechapel. Arrangements have been made for giving instruction in carpentry and turnery to boys, and in modeling and wood-carving to girls of the upper standards, and the results of the lessons have fully justified the most sanguine expectations of the advocates of this kind of instruction. Those who have visited these schools have been struck with the cheerful interest shown by the children in their work, and by the effect of the teaching in quickening their perceptive faculties and in stimulating their intelligence. The contrast between the listless and often inattentive attitude of children occupied with some ordinary class-lesson, and the eager eyes and nimble fingers of the same children at the carpenter's or modeling bench, is most instructive; and no one who has seen it can have any doubt of the educational value of this kind of training. These results, it must be remembered, have been attained by teachers most of whom have themselves been trying experiments, and have been working by the light of nature, without any well-considered methods. Under properly trained instructors the results would doubtless have been far more satisfactory.

There is good reason to believe that the stimulating effect of workshop instruction on the intelligence of children will be such, that, notwithstanding the loss of the time spent in the shop, their progress in their ordinary studies will be in no way retarded.

. . . . .

Nearly all educationists have pointed out the many advantages of enabling children at an early age to realize the connection between *knowing* and *doing*. Comenius has well said, "Let those things that have to be done be learned by doing them." Rousseau has pithily expressed a similar idea in saying, "Souvenez-vous qu'en toute chose vos leçons doivent être plus en actions qu'en discours; car les enfants oublient aisément ce qu'ils ont dit et ce qu'on leur a dit, mais non pas ce qu'ils ont fait et ce qu'on leur a fait" (Remember that in every thing your lessons ought to be more in actions

than in speech ; for children easily forget what they have said and what has been said to them, but not what they have done and what has been done to them).

. . . . .

In what I have said, I have endeavored to show that workshop instruction may be made a part of a liberal education ; that, as an educational discipline, it serves to train the faculties of observation, to exercise the hand and eye in the estimation of form and size, and the physical properties of common things ; that the skill acquired is useful in every occupation of life, and is especially serviceable to those who are likely to become artisans, by inducing taste and aptitude for manual work, by tending to shorten the period of apprenticeship, by enabling the learner to apply to the practice of his trade the correct methods of inquiry which he has learned at school, and by affording the necessary basis for higher technical education. — *Contemporary Review*.





