

UC-NRLF



5B 31 842

LIBRARY

OF THE

UNIVERSITY OF CALIFORNIA.

Class

FOI
CYI
DAI
CYI
ROI

PERFECTION BRONZE (cast metal) SCREEN
PLATES,
SECTION BOX COVERS,
COUCH ROLLS,
NAME PLATES,
PERFECTION BRONZE ONE-METAL DIGESTER, for
The manufacture of SULPHITE WOOD PULP,
PERFECTION BRONZE VELVETS, bolts and fix-
tures, for SULPHITE PROCESS,
BRASS COPPER and IRON WIRE and WIRE CLOTH
of every description,
BABBITT METAL and all grades of ANTI-
FRICTION METAL,
BRONZE and BRASS CASTINGS, from 1 oz. to
20,000 lbs. in weight.

N. B.—We MANUFACTURE all of the above
articles, not merely dealers.

Write for prices to

EASTWOOD WIRE MFG. CO.,
BELLEVILLE, NEW JERSEY, U. S. A.

FOI
CYI
DAI
CYI
ROI
PEI

SEC
COU
NAM
PEI

PEI

BR.

BA

BR

ar

ACME PAPER-MILL CUTTER

THIS is our heaviest and strongest machine. Designed for Paper Mills that have large and heavy work. All the mechanism is under table, entirely between the frames, out of the way. This is the most powerful and compact cutter made. Special facilities are provided for the rapid handling of heavy work. Sizes 48 to 72 Inches.

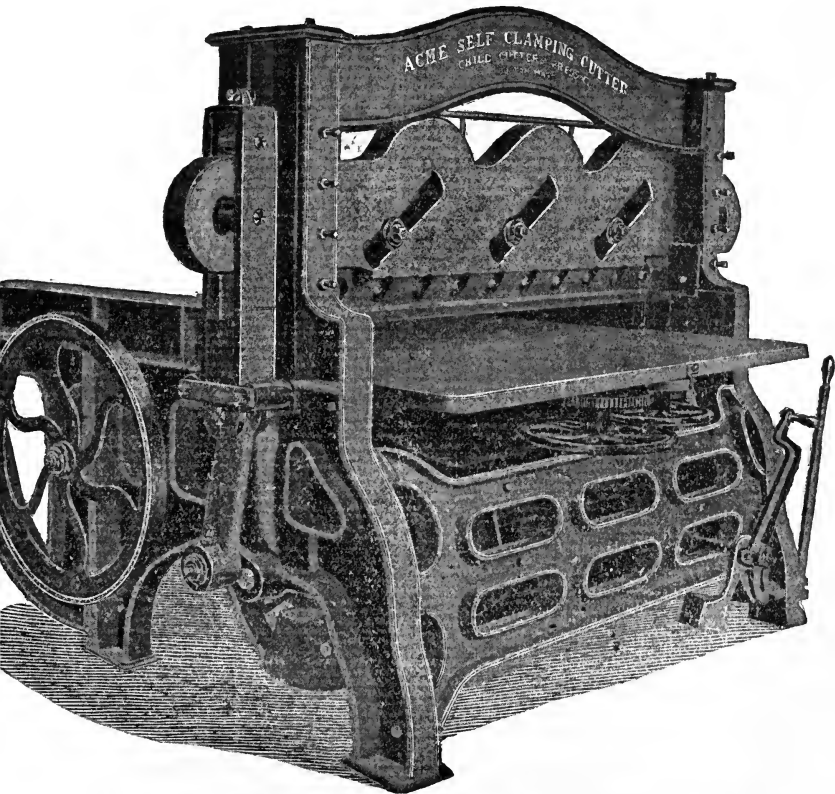

CHILD ACME CUTTER AND PRESS CO.
NEW YORK OFFICE, 12 READE STREET,
O. C. A. CHILD, Manager.
Factory and Main Office, 33, 35 and 37 KEMBLE ST.
BOSTON, MASS., U. S. A.

WATER
MARKS
TRADE
MARKS
AND
LABELS

} Are Valuable
Assets and
Should be
Protected.



WE HAVE THE ONLY BUREAU IN THE
WORLD WHERE YOU CAN GET ADEQUATE
REGISTRATION AND PROTECTION. 

THE ONLY SYSTEM
THAT PROTECTS.

SYSTEMATIC INSPECTION OF ALL LABELS
AND TRADE MARKS OF THE WORLD TO
PREVENT ADOPTION AND USE OF IMITA-
TIONS OF THOSE REGISTERED WITH US. 

 The International Trade Mark
Protective Company,

320 BROADWAY, NEW YORK.

THE MANUFACTURE OF
CELLULOSE.

A Practical Treatise for Paper and Cellulose Technologists, Managers and Superintendents,

BY

MAX SCHUBERT,

Royal Polytechnical School, Dresden.

Specially Translated for The American Paper Trade.

107 ILLUSTRATIONS.

ANDREW GEYER,

318 Broadway.

New York.



TS 174
Q 37

COPYRIGHTED 1899
BY
ANDREW GEYER.

GENERAL

PREFACE.

BEFORE complying with the request of Herr Fisher, publisher in Berlin, to compile for his technological library, a small work on "the manufacture of cellulose," I have first considered whether there existed a necessity for such. Although several short treatises on the comparatively new industrial branch, "the manufacture of cellulose" have already appeared, the main published information has been in the several volumes of the *Papier Zeitung*, and other trade journals which contain a number of articles about special departments of the industry and relating questions. The above mentioned compilations are treated in a general way and are short, forming chapters of larger works on the manufacture of paper, while the different articles in the papers are so much distributed among others, partly also connected with personal controversies and views, that I have become convinced of the necessity and the meritoriousness of the labor. To sift this comparatively valuable material, to complete it with personal experiences, and by adding practical advice, to create an up to date book on the subject of "Cellulose" seemed to me eminently desirable and I therefore seized with eagerness the task assigned me. I also communicated with some men closely connected with the manufacture of cellulose, and to them I am obliged for valuable details. I have found, however, that it is impossible to give an entirely exhaustive account of this branch, because not only are the many different systems in use in the manufacture of cellulose patented, but almost every manufacturer endeavors to invest his process with all possible secrecy. I have consequently treated copiously but one of the best introduced processes, and the others I have but touched, sketching in the principal features of each.

In starting the book I adopted the principle of treating the manufacture in its successive phases, and with each chapter to consider the peculiarities of the different systems one after the other. In this manner I have avoided repetitions, as some manipulations in the manufacture of cellulose are the same in all processes, especially as to the

beginning with the pulp wood as well as the finishing of the cellulose for shipping.

First of all the book treats of the raw material, the wood, with a description of the machinery necessary in it, and then passes over to the preparation of the leaches. Next the soda process is treated in connection with the regeneration of the soda and thereafter the sulphite process is considered in its different variations and latest improvements by text and illustration. The description of the processes of boiling in the different systems precedes the consideration of the boilers as differing in size, form, material and lining, and the methods for the finishing of the products follow.

A higher value, however, than on the description of manufacture proper and of the necessary apparatus and machines is to be placed on the open discussion, contained in the last chapter, of the difficulties, which are encountered in the manufacture of cellulose in the riddance and harmless disposal of the spent liquors and offensive gasses. The same is true of the practical advice which is given in regard to planning of new factories. The liberal use of cellulose has already caused a revolution in the extensive paper industry, as it is no longer absolutely necessary to look for accommodations of large water power, or to provide extensive rag lofts; because with steadily advancing improvement in cellulose its use will still grow. Consequently the circle of all those who are interested in learning the particulars about the production of cellulose and its properties must expand.

The expectation of success of the present book, as expressed in the preface to the first edition, has fortunately become fulfilled to me as well as the publisher; for besides the congratulations sent me from different sides, shortly after the publication, a French translation was prepared by the well known publishers, Baudry & Cie, in Paris, edited by sub-director Mons. B. Bibas. Almost at the same time I was negotiating for the preparation of a Russian edition with a Russian engineer, but I do not know whether the translation was executed, as on my mentioning of a trifling consideration, the correspondence from that side was cut off, and Germany is not in literary convention with Russia. Moreover, the entire edition was sold out in two years, so that many orders could not be

accepted. Outside causes were responsible for the long delay of the publication of the completed edition of this work.

During the last four years, although no new processes appeared in the manufacture of cellulose, a considerable number of changes and improvements were made, which deserved mention in the new edition. Those, therefore, besides the personal practical experience recently obtained have been incorporated in the new edition. I have also used all information which was furnished to me by the several inventors of the processes and the manufactures of machinery, and also, as in the first edition, several articles and sketches from the last volumes of the *Papier Zeitung*. In the new book the representation of the cell-stuff manufacture is so supplemented and rendered up to date and complete that instead of fifty-seven illustrations 107 figures are now necessary to supplement the descriptions.

I hope that the second edition of my work will fully meet its claim of offering in handy form all the information that is desirable to the technologist.

Dresden, September 1896.

MAX SCHUBERT.

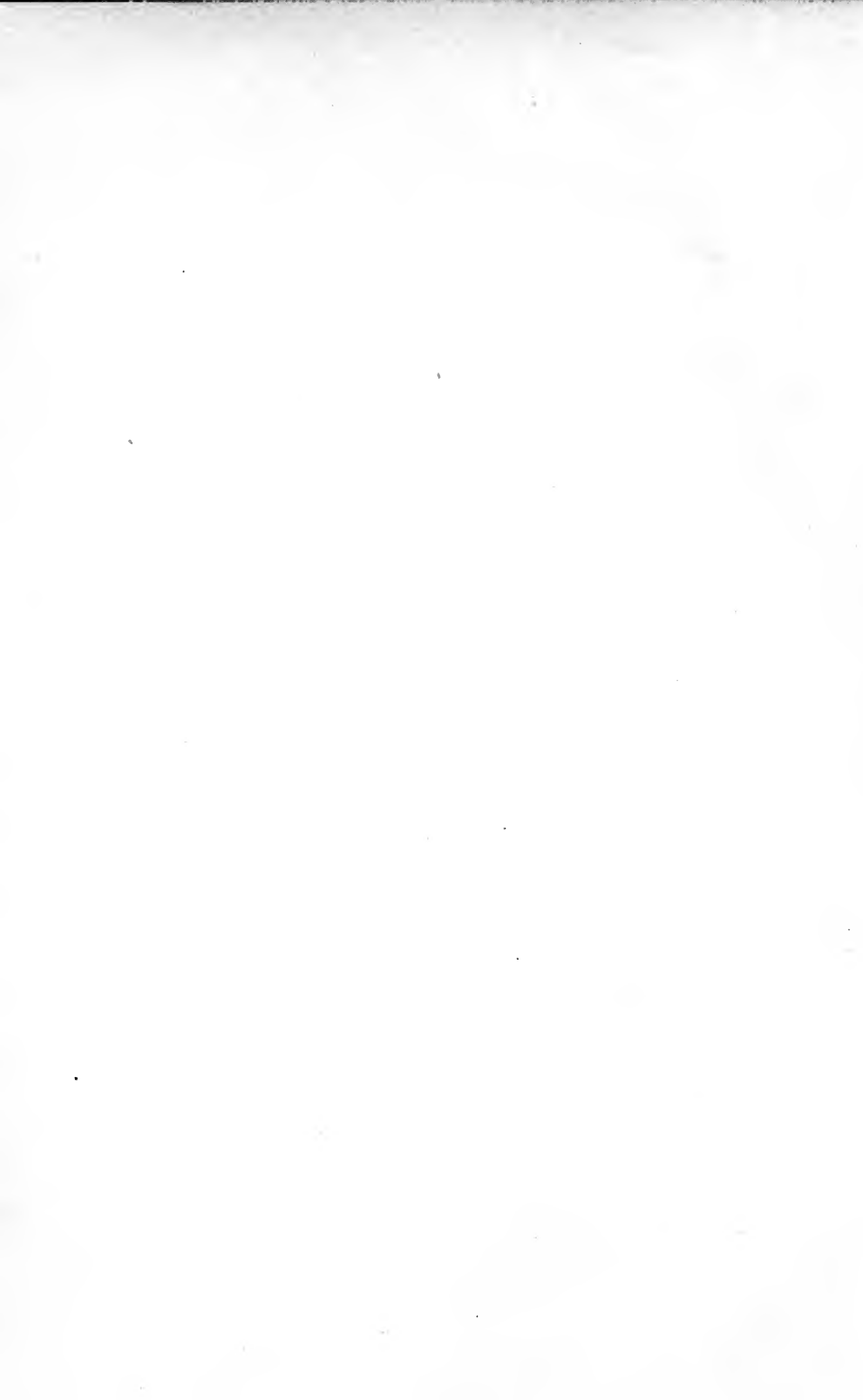



THE MANUFACTURE OF CELLULOSE.

Cellulose or wood fibre is one of the most important and most extensively diffused substances throughout nature produced during milenaries by the activity of the plants, stored up, though changed by terrestrial revolutions, in the form of coal and continuously renewed by the present flora. Consideration of the immense variety of these producers explains why wood fibre in a mechanical and chemical sense also shows great differences, so that the name wood fibre is really but an appellation, and for proper description the origin should be affixed every time, as has already been proposed from different sides. As, however, in practice but few kinds of fibre enter into question, namely, wood, straw and esparto, and as this book treats of the most important only which is ligneous fibre, the designation wood fibre will suffice, and when the more frequently used synonymous expression, "Cellulose" is employed, it should always be understood as wood fibre. The expression cellulose has first been used by Tessie du Motay.

With the exception of cotton the vegetable fibre is seldom found exposed, but is enclosed by different more or less soluble incrusting accessories. Mechanical disintegration of the wood does not separate them, although it furnishes as wood pulp a product, which on account of its cheapness, has been of great use to the paper industry, because it has made possible the production in large quantities of low grade printing paper. The short quality of ground wood pulp, its stiffness, poor felting capacity and its resistance to bleaching agents prevent it from becoming a substitute for wood fibre. Not until we succeeded in freeing the wood fibre from its incrustation by chemical means, and on a large scale at low cost, did we obtain a material capable of causing the revolution in the paper industry mentioned in the preface. As is the case with all important discoveries, it took considerable time before the experiments in the separation of vegetable fibre, dating since the year 1840, led to the practical results by which we have profited in so great a measure. By different ways, successively and repeatedly improving the method of their

predecessors, a number of men succeeded in manufacturing cellulose, and later on several large groups have become crystalized according to the method of manufacture. The thickness of fibre, strength, purity, elasticity and bleaching capacity of the different cellulose thus produced are to the advantage of the paper manufacturer, because the demands are endlessly varying and the manufacturer is in a position to select the different suitable sorts or to work in several at the same time.

Notwithstanding the different methods and the difference in the details of the manufacture a conclusion as to the best method of development has not yet been reached, for very lately, electricity has entered the arena, to assist in dissolving the incrusting constituents of the fibre.

The evolution of the very important invention of the production of cellulose may be best illustrated by the following chronological list of the names of those men who are either inventors of new methods or who merit notice by improvements and the introduction of practical apparatus, etc.

Year.	Name.	Dissolving Agent.	Method.
1840	Paven.	Nitric acid.	Acid process.
1852	Coupiér & Mellier.	Soda.	Soda process.
1853	Watt & Burgess.	Alkalies.	Soda process.
1855	Jullon.	Alkaline bases.	Soda process.
1857	Houghton.	Alkalies.	Soda process.
1861	Barre & Blondel.	Aqueous acids.	Acid process.
1864	Bachet & Machard.	Hydrochloric acid.	Acid process.
1866	Tilghmann.	Sulphite of lime dissolved in sulphurous acid.	
1866	Ekman.	Sulphite of magnesia.	Sulphite process.
1867	Fry.	Water of high temperature.	
1870	Dresel.	Soda.	Soda process.
1871	R. Mitscherlich.	Sulphurous acid.	Sulphite process.
1872	Ungerer.	Soda.	Soda process.
1872	Ritter-Kellner.	Sulphurous acid.	Sulphite process.
1873	Roemer (in Nettingsdorf).	Nitric acid cold method.	Acid process.
	Orioli.	Aqua regia.	Acid process.
1880	Cross.	Water with neutral sulphites.	Sulphite process.
1881	Francke.	Sulphurous acid.	Sulphite process.
1882	Pietet.	Aqueous solution of sulphur dioxide.	Sulphite process.
1882	Graham.	Sulphurous acid.	Sulphite process.
1882	Flodquist.	Sulphurous acid.	Sulphite process.
1883	Blitz.	Alkalies and sulphites. (Ammonium Vanadinate).	Sulphite process.
1883	Dahl.	Sulphate.	Soda process.
1885	Kellner.	Electricity.	Electric process.
1890	Lifschutz.	Nitro-sulphuric acid.	Acid process.

There are thus four processes: 1. The acid process. 2. The soda process. 3. The sulphite process. 4. The electric process. Of these, the first, the acid process is no longer of importance in practice; it has now but theoretic and historic value. Besides the above mentioned, nitric acid, nitro-muriatic acid, muriatic acid and sulphuric acid were also used by some for the purpose of cellulose manufacture, but on account of many disadvantages were discarded when the other methods proved more practical. These three other methods, viewed from a general standpoint, have one point in common. The cellulose is produced by treating the disintegrated wood with a solution under pressure in a boiler and by washing and milling. The details naturally vary, some manipulations, however, especially at the start and finish are the same with all methods. In this treatise, which is to serve in practice first of all, the methods shall, therefore, not be gone over one by one, as then much would have to be repeated; but the whole of the cellulose manufacture will be described in its successive phases, while the variations of the different systems will be considered as points of difference arise.

Efforts have been made to produce cellulose from every kind of cheaply obtainable wood species, leaved wood as well as pine, but in general the wood of the pine and fir have given the longest and best fibre, though even in pine this varies according to the location of the tree, and its quicker or slower growth. Pine wood cells measure up to 9 mm. the longest way, while the leaved woods have a much shorter fibre. The quality of cellulose yielded by different woods may be seen in the following table by R. B. Griffin and A. D. Little.

Species of Wood.	Lacker, Gum, etc., soluble in water.	Fats, Resins, etc., soluble in ether and alcohol.	Zellstoff.	Incrustations and binding substances.	Result by the sulphite process of unbleached fibre.
Fir	2.81	2.73	66.32	28.14	50.75
Poplar	4.80	1.85	80.35	13.00	55.18
Birch	2.14	0.93	82.99	13.94	42.80
Yellow birch	1.88	0.97	82.36	14.79	53.80

In regard to soda-cellulose the following table is interesting. It gives the yield in cellulose from one volumeter each of the different kinds of wood; it also gives the loss by barking and cleaning.

Species of Wood Recently Cut.	1 volumeter weighs	Loss by barking and cleaning,	Loss when dried at 100 degrees C.,	1 volumeter barked and dried at 100 de- grees C. weighs,	Yield in Cellulose,	Per Yield in Cellulose, cent
	Kilo.	Kilo.	Kilo.	Kilo.	Kilo.	
Pine	617.5	80	230	307.5	108.2	35
Spruce Fir	566	136	191.7	238.3	88.2	37
Scotch or White-fir...	697.5	170	252.2	275.3	105.7	38
Black Fir	707.5	147	235.6	274.9	89	34
Larch	597.5	90	160.37	347.13	116.8	33
Leg Fir, dwarf pine...	449.3	55.1	124.8	269.4	99.81	37
Red Beech	865	70	327.54	467.46	139.8	30
White Birch	623.5	111.5	215.04	296.96	85.6	29
Asp	695	135	227.36	332.64	108.42	32
Poplar	650	175	226.5	248.5	88.14	35
Mountain Ash	725.5	131.5	269.67	324.33	100.6	31
Wild Service Tree....	756.5	166.5	224.2	365.8	103.96	28
Border Willow	572.5	80.5	241	251	85.7	34
Brittle Willow	583.5	111	181.4	291.1	104.8	36
Ash	593.5	91	100.1	402.4	103.95	26
Alder	516.5	97.5	181	238	82.3	34

The above analysis shows that the yield in cellulose, expressed in percentage, does not vary much in the different kinds of wood, though in general the pines give a somewhat larger amount of cellulose. Besides this the quality of cellulose from pines is better, and as this wood is more plentiful, the price is lower. As a result these kinds are principally used.

The Scotch pine, though abundant, in some countries and cheap, is on account of its large content of resin, seldom used for cellulose, although under certain conditions it yields a good product as Herr Dresel in Dalbke has proved by his method.

Since the manufacture of cellulose and wood pulp has reached such immense proportions speedy extirpation of our forests by this industry and the inevitable consequences of irrational forestry are suggested. Fortunately

a satisfactory answer to this can be given by the following figures and explanations, which are taken from a lecture by Dr. Frank as published in the Papier Zeitung:

"In Germany there at present about sixty cellulose factories, which work into wood fibre stuff about 2,000 festmeters, equal to 3,000 volumeters of wood per day, thus turning over thirty millions of marks per annum, of which amount about ten millions will flow into the treasury of the forest administration. This daily quantity of 3,000 volumeters requires the cutting of an area of six to eight hectares of forest. According to information from a competent party in Germany, in sixty years rotation the average yearly yield, in solid wood may be put for fir at 3.1 festmeters, for pine 4.9 fm., so that the yearly need of our cellulose factories to the amount of 600,000 festmeters the regular yield of a forest area of from 150,000 to 160,000 had is fully required. Pine being especially suitable for wood fibre the prices of this wood, which formerly on account of its poor qualifications for timber were far below those of fir, have rapidly risen and the far-seeing Prussian forest administration has already by increased cultivation so well met this condition that at present 274,416 hectar of pine forest in the possession of the State contain 8,308 hectar of 100-year stock, 17,727 hectar of 81-100-year stock, 30,752 hectar of 61-80-year stock, 48,413 hectar of 41-60-year stock, 65,616 hectar of 21-40-year stock, 92,675 hectar of 1-20-year stock. To this increased pine culture, in which also the forests in private possession will follow suit, is the more important; as in the manufacture of wood fibre we must reckon with the competition of other countries, which get the wood material much cheaper than we do; in Europe there are especially Sweden and Baltic provinces of Prussia, both very favorably situated countries for export, and in America, Canada now enters into competition with equal facilities.

A festmeter of pine wood weighing about 450 kilos, above 7 festmeter correspond to about 3,150 kilos of pure wood pulp and as 6 festmeters pine wood yield about 1,000 kilos of pure wood fibre, the annual yield per year of the pine would correspond to 1,166 kilos of cellulose produced thereof per hectar.

Each individual cellulose concern must procure the most suitable pulp wood at the lowest shipping expense. In

this connection it is to be considered that freshly cut wood is the easiest worked, and produces the best cellulose, but it weighs heavier and by increase of freight becomes dearer. It is therefore to be recommended that when the logs first enter the factory they be assorted, separating the older and dryer ones. Of the dry, which were lying in the woods a considerable time, special care is to be taken to throw out those rotten in the core, because such partially reddened wood produces but inferior cellulose. In any case, when cutting the logs later on, the various pieces, exhibiting a change in the white wood color, should be laid aside, to be used as kindling wood, or when enough has accumulated to be worked into third quality cellulose.

WOOD WORKING.

The wood used in cellulose manufacture must first be barked, and such is done either by hand, with the knife, or by a barking machine, also by both methods successively.

When heavier wood has to be worked, and when the barking is to be done by machine, it becomes necessary to cut the logs with a log saw, swinging like a pendulum, into pieces of about 60 cm. long. In figures 1 and 2 such practical saw is illustrated. A wooden frame, the length of which depend on the height of the workshop, is on its upper end provided with two wooden pins, resting in two hanger boxes BB. In the lower end of the swinging frame is rested a short shaft, to which on the left is fastened the circular saw-blade of 860 mm. diameter, which by transmission receives a velocity of about 900 revolutions per minute. In front and at the side of the circular saw is placed a wooden frame, provided with sliding rollers, upon which the log is laid and easily pushed against the saw-blade.

With his right hand the operative presses the toothed lever against the log, to hold it in position and with the left hand with one grasp he pulls the rotating saw against the log, cutting through it rapidly. Its own weight at once brings the frame back to the vertical position, the helper again pushes the log ahead and the cutting is repeated. In this operation it can be easily noticed on the cut edges, whether the wood is part good or part rotten, and the bad pieces are thrown out, as stated above. With great rapidity now follows the use of the barking ma-

chine, of which figures 3, 4 and 5 show a practical construction.

Encased in a cast iron frame the barking machine is

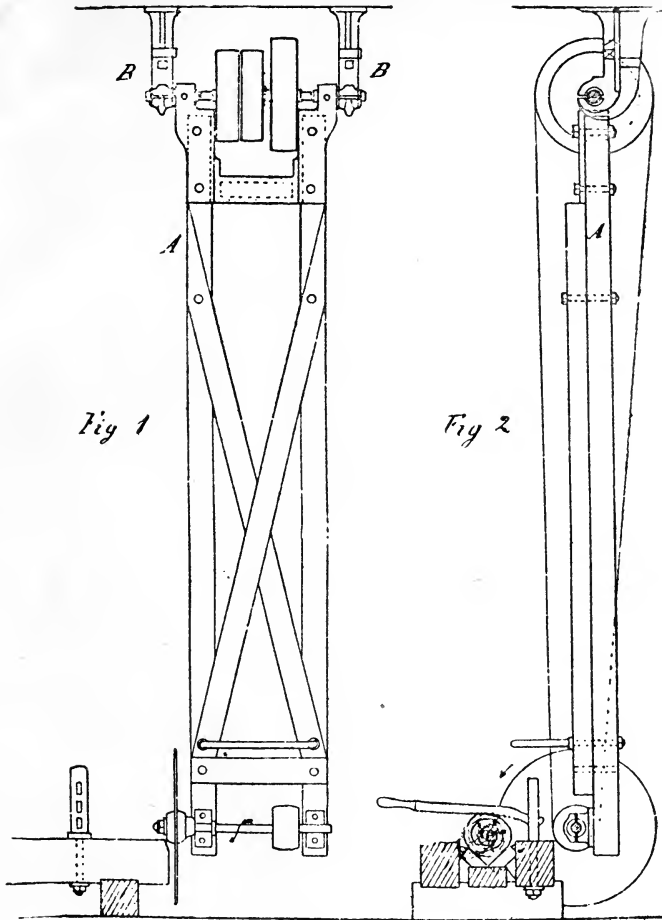

BLOCK SAW.

set upon a vertical shaft, the principal part, a circular table or wheel of 830 mm. diameter, revolving 330 times per minute. This wheel has near the periphery five slits,

as shown in figure 4, through which from below, diagonally movable knives are put, which are raised above the table but a few mm., and while rapidly revolving peel off

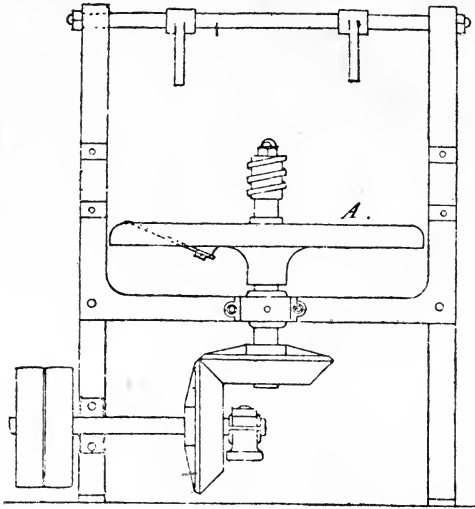

Fig 3

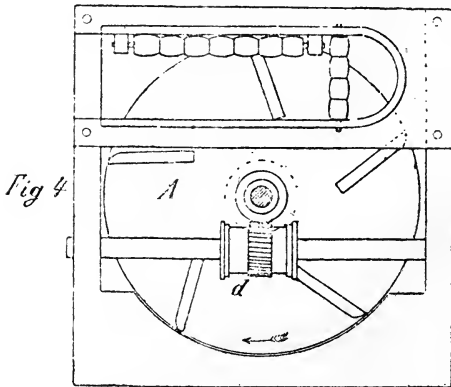

Fig 4

BARKING MACHINE.

in long slices the bark off the wooden block c, which is pressed against the knives by the lever 9. As the block is

also kept turning by a toothed wheel, the barking is done equally over the whole circumference. If now all blocks were exactly cylindrical, the work in the manner described would suffice, but some pieces are crooked and often have humps and hollows, and it is also necessary that not only the brown bark, but also the underlying white bast be removed in order to produce a good cellulose. Consequently after cleaning with the axe or knife on the ordinary work bench must follow. Exact experiment by the author with wood of estimated weight and nearly equal bulk have shown the following results. When the wood is barked by machine and after cleaning by hand, 10 festmeters cost about 5.5 marks for labor, while 10 marks have to be ex-

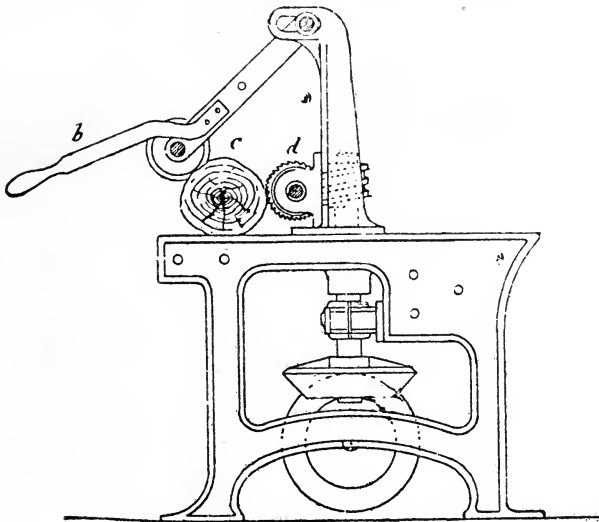

FIG. 5. BARKING MACHINE.

ended when barked by hand only. In the latter case it is true the loss by barking is about 1.4 per cent less, nevertheless the use of the machine is to be recommended, as thus much time and money are saved.

In place of the above described barking-machine a so-called duplex may be used, on which two blocks can be worked at the same time, or also one with a wheel rotating vertically. The barking shop is generally located on the ground floor of the factory. By an elevator the barked

blocks are then transported to a higher floor to be still more diminished. Some manufacturers at this stage have the knots bored out, because as these do not become soft in boiling they do not yield cellulose, and further the fibrous parts, laying next to the knots as a rule remain hard, or at least yellow. Even by boring them out, they cannot be removed entirely, so that it seems advisable not to sort them out until later. The diminution of the wood, necessary for the more thorough action of the leach in the subsequent boiling may now either be done with circular saws which cut the blocks into slices of 25 to 30 mm. thickness, or by chip—or cut—machines. In the former case according to the capacity of the plant a larger number of ordinary single circular saws or those with several saw-blades in a row are used as a rule. Because the labor of feeding has to be done by hand and accidents to those em-



FIG. 6.

ployed therein may easily happen, it is necessary to provide all possible safety arrangements and especially caps over saws. In order that the operatives, who mostly do the sawing by contract, do not make the slices larger than desired, it is advisable to fasten to the table in front of the saw a small angle iron, which stands sideways about 25 to 30 mm. off the saw-blade and answers as a guide. The shorter the block becomes the greater the danger for the operative, if he presses the block against the saw with naked hand. If the operative uses a short piece of wood with a handle on one and several steel points in the other end, which he pushes every time in the head of the block to be cut, he can thus easily guide the block and the danger of possible injury is almost excluded.

In using circular saws it is very important to take care that the saw blades are thin, the best possible, and that the

set of the points of the teeth of the saw (the spreading) to the right or left is just so much, that the saw does not get clogged in cutting. The waste of sawdust, even with observance of the precaution mentioned, is very large in proportion, and may increase if these directions are not followed. When slices of 25 to 30 mm. thickness are to be cut, in every log of 1 m. length at least 33 cuts have to be made, and when for each of them but 4 mm. loss is admitted, the result is 132 mm. per thousand, or 13 per cent. Though this waste appears very clean, it yet contains many small particles of knots, yielding brown spots in the cellulose. If too high demands are not made on the product, the dust may be filled in the boiler together with the slices, the whole or part of it mixed, but care should be taken that it is placed in about the middle of the total charge of the boiler so that in discharging the leach it would not clog the valves, or when swimming on top it would not spoil the whole operation. It would certainly be better to leave out the dust entirely, or at least to use it together with low grade wood for a cheaper quality. At this point may be mentioned, that lately the shavings from barking, especially such not charged with brown bark, are boiled into cheap cellulose by some manufacturers. Because, in proportion to their weight, not many can be filled into the boiler, they are cut by a chopping machine into short fragments, which often being charged into the boiler are trodden down by a laborer, so that the yield in cellulose in each operation is but 10 to 15 per cent. less than in an operation with good wood. In this manner the working of shavings is made profitable, while previously they were mostly used as fuel. Mixed with sawdust or waste from pulp milling, they may also be worked into lesser grades of wood fibre. It may also be mentioned that with the above described methods of cutting wood, the knots existing in the different slices are, as a rule, not sorted out before boiling, because the smaller ones could not all be picked out by any means, and sorting after boiling would still be necessary. After the wood is softened by boiling, every knot can be detected with the finger and easily picked out.

When a chipping machine is used in reducing the wood to be boiled the disadvantage of great loss of saw dust is eliminated, because the previous barked wood is hewn off

the head in somewhat oblique direction in fragments, measuring about 30 mm. In consequence of the forcible bearing away the particles also receive cracks in all possible directions, thus becoming loosened and permitting the leach to permeate them in the subsequent boiling. The main part of such chipping machine is a heavy cast iron wheel of 1,400 mm. diameter on a strong horizontal shaft. To prevent springing a ring of forged iron, 50 mm. wide, is fastened around it while warm. Near the circumference one or two strong knives are fastened, each by nine screws, which stand about 5 mm. off the wheel and which move quite rapidly on a stationary support, over which the wood to be cut is introduced. When lighter wood is worked the previously hand-barked pole is fed to the machine by two men, and must be turned about after each cut. Another laborer shovels the chips upon the elevator, which takes them to the upper lofts. The machine naturally requires much power and because it continuously receives heavy shocks, it is best to place it on the ground floor, and as stated, to transfer the cut wood upwards. The machine is capable of chipping in 12 hours about 35 cubic meters of wood from the head of poles about $2\frac{1}{2}$ m. long. In some factories, however, the machine is placed in upper lofts; the wood is in short pieces, previously peeled on the barking machine, and the blocks are put on an endless band and automatically led to the chipping machine. The wood, reduced as described above, is moderately filled into the boilers in cases where the factory does not work prime cellulose. In most cases, however, it is first assorted by a number of boys or girls. For this purpose it is thrown upon a sifting table, where dirt and very small chips fall through and every piece containing a knotty part, is sorted out by hand. This method is quite expensive, and in each case particular care should be taken in calculating whether the cost of labor for sorting is recovered by the production of a high grade and pure cellulose.

A later design of a chipping machine, described in the *Papier Zeitung*, originates from geh. Commerzienrat Albert Niethammer and seems to be based on the principle of pencil sharpening. By this method the wood is not cut directly across the grain as in some machines, but is sliced off in long chips. In this manner the machine requires less power and has to suffer much less violent

shocks. The cutting away almost vertically on the long axis of the wood is not desirable on account of the large consumption of power. As a rule an angle of 45° is accepted as the most effective, for where the wood is cut at that angle the cells are opened, and the wood inside is crushed and loosened to such extent that the leach can enter easier and quicker. Whether the knife, which does the principal work, and which in this machine had to be made thin, has worked well, is not known to the author.

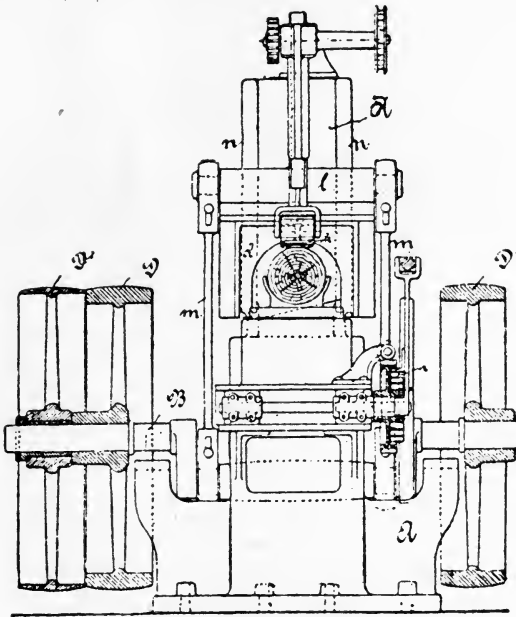

FIGURE 7.

The entire construction can be learned from figures 7, 8, 9 and 10 and from the following description:

Fig. 7 presents the front view, fig. 8 the side view, with part cut, fig. 9 the view from above (the plane), fig. 10 shows in enlarged scale the knife holder with knife.

The frame A, in which is the cranked driving shaft, develops upward into a stand A', the front face of which is inclined. To the stand A' the adjustable guiding posts n are fixed, along which a sled f can be moved up and down

The latter carries the knife *a*, with the frame *d* (fig. 10), covering it at the edge. With the knife-sled *f* is connected a cross beam *l*, to which are connected the two driving rods *m*, linked to the crank of the driving shaft *B*. On the right and left of the shaft, outside of the bearing boxes are the fly wheels *D* and *D1*, one of which serves as driving pulley. Alongside of this is the loose pulley *D2*. It is at once evident that the sled *f* with the knife and the cover-frame in one turn of the shaft *B* makes a lift along the inclined face of the frame *A1* corresponding to double the length of the eccentricity of the shaft crank. By using

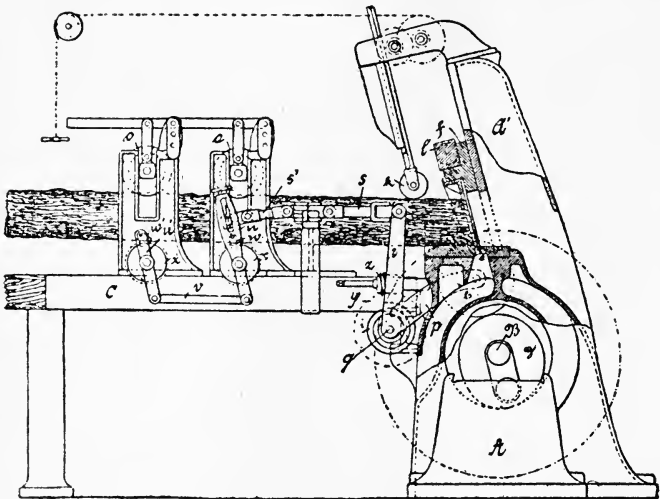

FIGURE 8.

two connecting rods, cornering of the knife-sled *f* at the adjustable leaders *n* is prevented. The log is fed upon a table *C* in a direction oblique to the axis of the shaft *B*, but in level position, so that the line of the cut is inclined to the long axis of the fibre, as well as to its perpendicular, and thus the fibres are cut through in a doubly inclined direction.

To obtain undamaged slices the knife has to be very thin, and to give to the thin knife (fig. 9) sufficient resistance and stiffness, it is fastened to the knife support *f*, not only with its upper edge, but also with both sides with screws,

and the latter as well as the frame d, covering the upper side of the knife, are for this purpose cut out in a semi-circular form.

The knife, the edge of which is somewhat beveled, does not cut against a stationary, so called stock-knife, but enters in its lowest position into a correspondingly wide slit of the log support. The automatic advancing of the log is secured by means of two pairs of rollers, upon one of which lays the log, while the second pair of rollers (o) holds the log in the proper position from above.

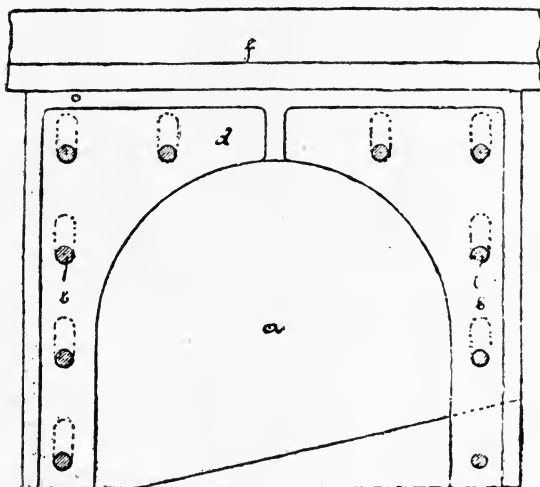

FIGURE 9.

The feed is broken during about one-quarter of the revolution and is going on only when the knife has accomplished the upper part of the motion. In this manner it is possible to cut logs of a diameter equal to three-fourths of the lift of the knife. This periodic feeding is secured by the eccentric (g), which is fixed to the shaft B and upon which runs a roller (h), borne in the arm (p) of an angle-lever (pr), turning about the pin (q). The second arm (r) of this lever is, by the car (s), which is provided with a universal joint, connected with one arm (t) of the angle-lever (tt1); the second arm (t1), by the push-bar (s1), also provided with universal joint, is likewise connected with the lever (u).

When the pulley (h) is lifted by eccentric (g) the bar (s1) (fig. 8 and 9) is pushed to the right and hence the two levers (uu1), which are connected together by the push-car (v), also stick to the right with their upper ends. On the upper ends of these levers are friction latches (ww1), provided with rollers, which trail upon the edged disks (xx1) in a way that, with the above mentioned swinging to the right of the lever ends the disks (xx1) are carried along. With the swinging to the left of the lever ends, the latches

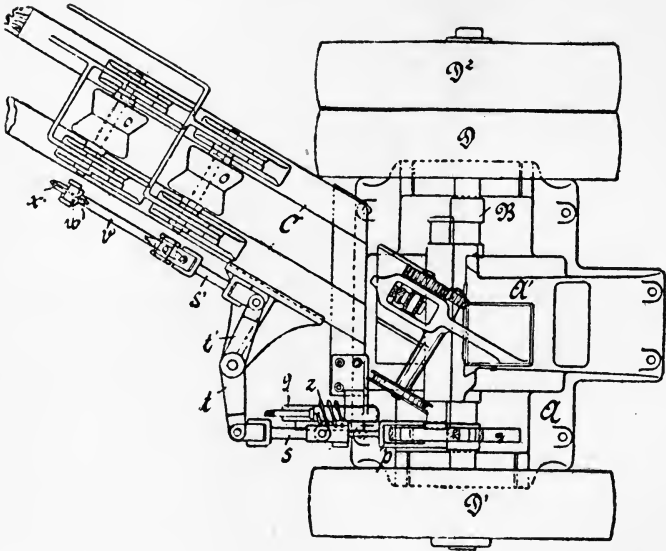

FIGURE 10.

(ww1) slide back over the final rollers. The levers (uu1) turn loosely on the spindles of the disks (xx1). The spindles bear the rollers, which support the log from below, so that with every turn of the disks (xx1) this pair of rollers will also turn, and thus the log is correspondingly pushed forward. The end of the bar (s1) at its connection with the lever (u) slides in a groove by which means the amount of feed can be regulated. The pulley (h) running on the eccentric (g) follows the latter when the number of revolutions is low, but when 80 to 90 per minute the molecular

forces act hinderingly, and the pulley does not follow the delivery of the eccentric curve with sufficient quickness. To avoid the shocks which would result, a spiral spring (i) is arranged, which with one end is fastened to the angle-lever (pr), and with the other to a spiral wheel (y), which is in action with a second spiral (z), put in rotation by means of a key, so that the spiral spring can be suitably adjusted to give the necessary acceleration to the pulley. A small roller (r), borne in one end of a toothed bar, serves to hold down the log before the knife.

In conclusion the author has computed a table from practical observations, to ascertain whether it is of more advantage in the manufacture of cellulose to use light or heavy logs. These values refer to the first mentioned case, where the wood is cut into slices by the circular saw.

Centimeters. Thickness in	Meter Length per Volumeter Wood.	Circumference in Centimeters.	Surface to be Barked per Volu- meter in Sq. M.	Number of Cuts by Block Saw.	Number of Cuts When Slices are 30 mm. Thick.	Cross Section in Square Centimeters.	Face of Cut per 1 Volumeter in Sq. M.	Time per 1 Cut Average in Seconds.	Time per 1 Cubic Meter and 1 Saw in Minutes.	Time per 100 Cubic Meters and 2 Saws, Work Days of 10 Hrs.
9	121	28.26	34.2	242	3936	63.6	25.00	1.5	98	8.17
10	100	31.4	31.4	200	3200	78.5	25.12	1.85	59	4.91
15	44	47.1	20.7	88	1408	176.5	24.85	2.2	51	4.3
20	25	62.8	15.7	50	800	314.0	25.12	3.6	48	4
25	16	78.5	12.5	32	512	489.8	25.07	8.8	75	6.25
28	14	87.9	12.3	28	470	615.4	28.9	13.6	94	7.8
30	11	94.2	10.4	22	352	706.5	24.86	18.5	112	9.3
34	9	106.7	9.6	18	269	907.4	22.4	34.0	152	12.7

This computation is not quite carried in practice, as for instance for woods of 10 m. thickness, 10x10 100 pieces are set in 1 square meter. With close observation one may learn from this table that with thinner wood, the surface to be barked, and consequently the waste is the largest; therefore it would be of advantage to work only very thick trees, if prices were the same. The cross section really to be cut in one volumeter of wood is almost equal in thick and thin wood, namely, about 25 sq. m., whereas the working time necessary to cut one volumeter of wood of light, medium and heavy quality into slices of 30 mm. thickness differs greatly. It is the great number of the necessary

cuts and the loss of time between the single cut in thin wood which makes its use unprofitable; while in very heavy wood the saw meets too much resistance, becomes clogged, goes slower and takes considerably more time to do the same work. But as time is money and very heavy logs have a higher timber value, their use is not recommended. The table shows plainly that it is the most profitable to buy medium heavy wood of about 20 cm. diameter. As a consequence of the continually increasing competition and

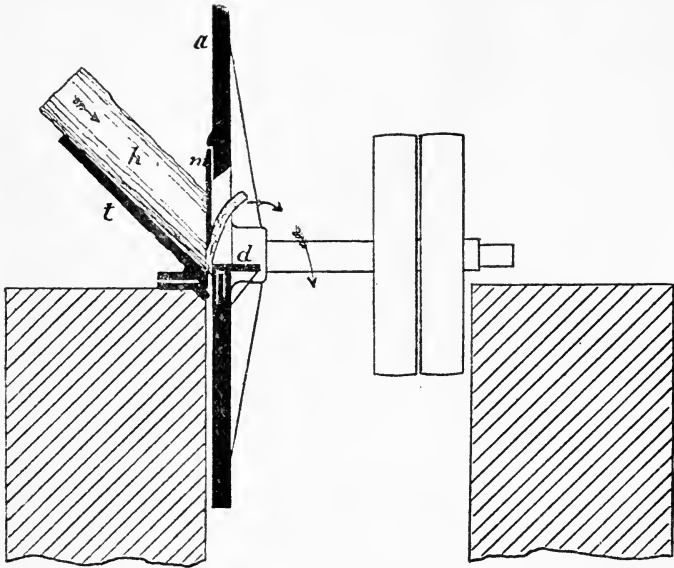

FIGURE 11.

the increased demands of the wood fibre consumers many changes have taken place in recent years, in the working of the wood, which, without regard to the different patent processes in the manufacture of cellulose have found admittance uniformly in the factories of the different systems, as it is now the main object to save as much as possible in power and labor, as well as to manufacture a product as pure as possible. A plant already introduced in a great number of factories by the foundry and machine works (formerly Goetjes & Schulze in Bautzen, fulfills

these conditions, and the machinery previously used has been connected with the new and shaped into a practical whole. In the process the logs are cut by a log-saw in blocks of 1 m. or less as already described. These are barked by a single or double barking machine and, when heavy wood is used they are also split by a splitting machine, such as are in use in wood pulp factories. This splitting is for the purpose of facilitating the work of the chipping machine, because the hewing of the chips off heavy logs requires decidedly more power than off a thin one. The chipping machine, as already mentioned, is at

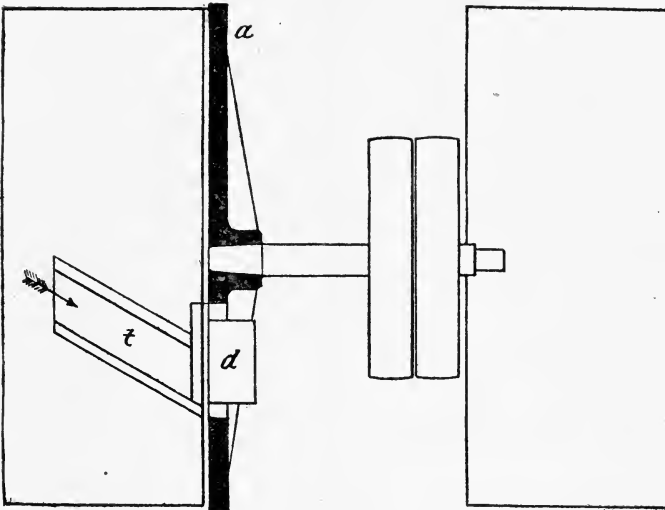

FIGURE 12.

present usually built with two knives and the feeding of the wood is not as originally practiced, oblique to the horizontal and vertical to the ground section of knife blades, but oblique to both directions, as shown in figures 11 and 12.

Thus the cutting of the chips is done along the long axis of the wood, which is naturally easier, than hewing of the head wood. The feed arrangement is obtained by a semi-circular gutter, which is cast to the frame and in which the log-pieces are placed, being fed to the knives by their own weight. As the knives are 500 mm. long and 150 mm.

wide as a rule, two guiding gutters alongside each other are provided, so that two logs may be cut at the same time. When care is taken that the knives are always sharp, which necessitates a change every two hours, such chip machine can in twelve hours cut as much wood as is needed for a daily production of 6,500 kgr. of dry cellulose. This repeated changing of the knives is further to be recommended, because of the fact that they get warm in the working.

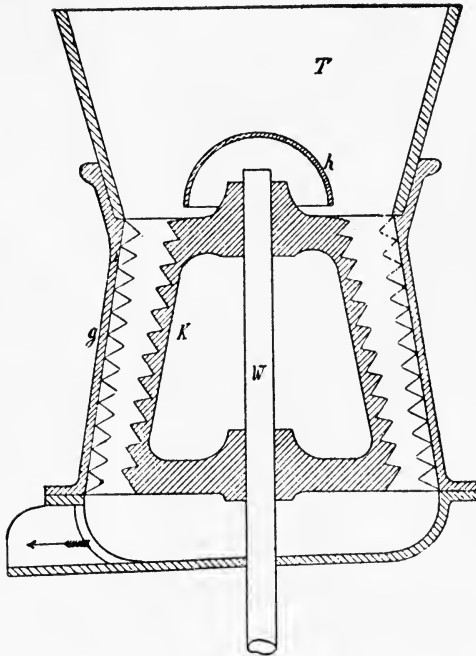

FIGURE 13.

The chips hewn off then fall below the machine directly upon a wide band, moving slowly along, and carry the wood to the so-called breaker. On the way there the principal and largest knots are sorted out. Contrary to Professor Mitscherlich, who has recommended the cutting into slices, Dr. Karl Kellner has found from the beginning that the most thorough splitting of the wood fragments is of advantage in permitting the entrance of the leach, and there-

fore was not satisfied with the effect of the chipping machine alone, but besides uses the breaker, which is constructed after the common coffee mill, as shown in fig. 13.

The chipped wood, which in consequence of the force and strain of the chipping is already full of minute cracks, is fed by the elevator to the funnel, into the casing (g), which is conical in shape, widening towards the bottom. The wall of the casing is provided with sharp teeth and within a smaller cone K, also set with teeth, is revolving rapidly. The distance between the stationary and movable parts is so proportioned that the chips of wood are considerably re-

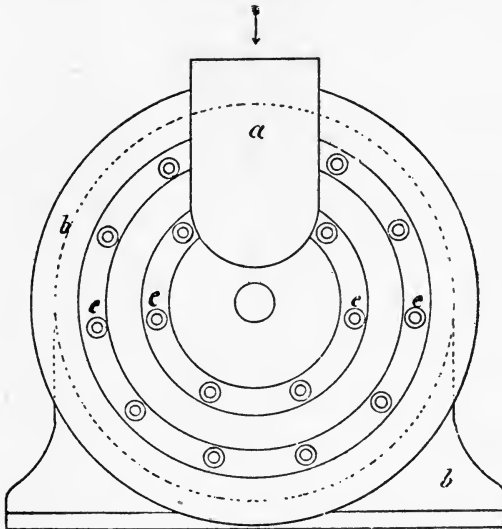

FIGURE 14.

duced in size, while the harder knots fall through unbroken. In place of this breaker the centrifugal machine has been lately used with success. It is claimed to work more advantageously because it does not tear the fragments so much, and renders easier the separation of the knots and knotty parts from the sappier wood. A cross section of the characteristic parts is shown in fig. 14, and in fig. 15 the front view.

Inside of a casing, on the front wall round pins of forged iron are set in two concentric rings, between which two

smaller rings of pins are rapidly moving. These latter mentioned pins are set in a round disk, which is wedged on a horizontal shaft. The elevator throws the chips of

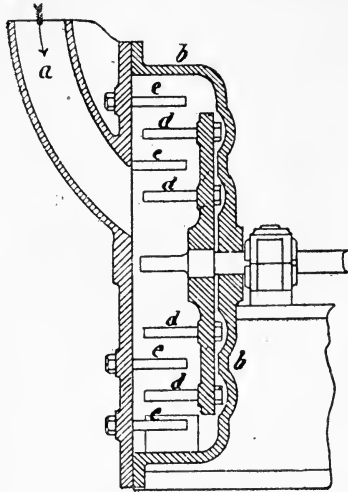

FIGURE 15.

wood into the flat pipe (a) cast to the front wall, from where they enter immediately over the shaft into the middle of the apparatus, get caught by the pins of the

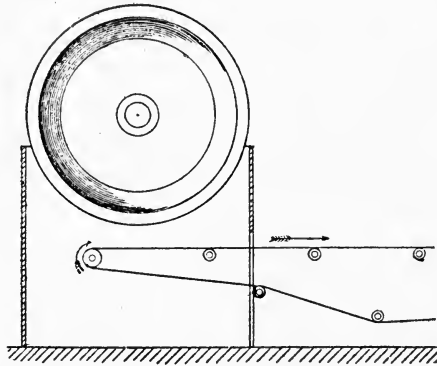

FIGURE 16.

rapidly rotating disk (about 1,000 revolutions per minute), thrown around, crushed and separated from the knots.

Through an opening in the case the wood then falls upon an elevator band below, which carries it further to the rotating apparatus.

For a quantity of 6,500 kilos of dry cellulose supposed to be worked per day, this machine consists of two conical drums of 6 to 7 m. long and about 2 m. in diameter, the constructions of which is shown in fig. 16 and 17. The drums, made of wooden rings, rest in the front, rear and eventually in the middle upon two driving rollers each, which rotate rapidly, the large drums making about 12 revolutions per minute. The inside of the wooden frame work is lined with perforated sheets, thus forming a smooth, large funnel, into the smaller end of which the fine wood is carried by the elevator. By rotation of the cone the wood is carried up part of the circumference, and

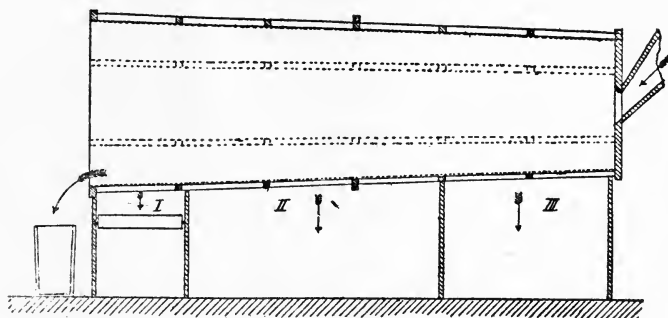

FIGURE 17.

thus slides along the smooth wall towards the wider end of the funnel, or falls through the numerous openings under the drum. Because it must perform at the same time a cleaning, as well as a sorting of the pieces according to size, and possibly also a separation of the knots, the foremost smaller part of the drum lining has fine holes of about 6 mm diameter, a second part has larger openings and the third part at the wide of the funnel has the normal openings, which answer the size of the good pieces to be worked. Below the first and second department are boxes closed by doors, in which the sifted material accumulates. This consists in No. 1 of dust, splinters, knotty particles and fine black knots and is either used in the factory for kindling, or sold for other purposes; No. 2 con-

tains medium sized pieces, mixed with some knotty parts and when enough has accumulated, it is separately worked into second quality ware. The good wood from No. 3 falls upon a band about 1 m. wide, which is at a right angle to the drum, and carries its load slowly along, serving as a table, at both sides of which girls are standing, who sort out all pieces, which still contain knots. The main part of knots will be larger than the opening for the good wood and at the wider end of the funnel drops into a basket. The contents of this basket naturally is again gone over and larger, but clean pieces of wood, are sorted out to be further worked. Because the use of elevators saves much hand labor, one or more other elevators now expedite the wood to a floor above the boilers into boxes, the capacity of which corresponds to the boilers below.

LEACHES AND LEACHEMAKING; THE SODA PROCESS.

As the name suggests, soda is used in the soda process, as leach in boiling. Originally this was in the form of carbonate of soda, made caustic by adding lime, in order to dissolve the incrusting constituents of the wood fibre and to separate them from the pure fibre. In itself the soda does not make the solution effective, but water must be present and a high temperature must be employed. The hot steam alone renders some of the incrusting constituents soluble, and thus other products are formed, also acids, which have dissolving qualities, but would have an injurious influence on the fibre itself, were it not for the fact that the presence of the soda neutralizes them while the process of boiling is still going on. This depends principally on the proper strength of the leach and maintaining the necessary temperature (corresponding to the pressure of the steam in atmosphere) also the length of time for the process of boiling in proportion to the quantity of the wood and its quality. It is quite natural that the most diverse statements were made about this before practical experience has established proportional values. Professor Hager wrote in this regard the following: "In 1869 a tension of 4, 5 atmospheres (150° C) was considered sufficient by Keegan, while Lee in 1870 went up as high as 11 atmospheres (210° C)—Ungerer in 1872 has asserted that a pressure of from 3 to 4 atmospheres (134°-144° C) for leaved wood and from 5 to 6 atmospheres

(152°-159°) for pine wood answers the purpose, while Rosenham in 1878 again stated that 10 atmospheres (180° C) was correct. The statements by Ungerer seem to fit the purpose best. However an account of the great risks, presented by the high tension in boilers of such immense dimensions, the pressure of 10 atmospheres (180° C boiling temperature) should not be exceeded. In similar manner, the quantities of soda employed, and the strength of the leaches deviate. According to the patent of Wott & Burgess, the leach is made 12° B strong, of which so much is taken that to 100 parts of wood, considered dry, 21 parts of soda of 60% purity are used. Sinclair has used 25 parts of soda for 100 parts of wood, in a solution of 140° B. According to Ungerer, and employing his system a leach will do, of which 4-5% of caustic soda of 60% purity is used with leaved wood and 6-8% to pine wood. Much less varying are the statements about the time of boiling, which as a rule is stated at from 5 to 6 hours for one operation."

These reports by Professor Hager, in conformity with communications to the author, are to be corrected by the statement that a pressure of 4 1-2 atmospheres is by no means sufficient in the production of soda-cellulose; and on the other hand, that until 1870 Lee has not been employed in the task of making wood fibre, and also that up to 1872 Ungerer had not yet boiled cellulose. Besides the latter had not employed 5 to 6, but 8 to 10 atmospheres of pressure. It is mentioned conclusively that Unger's process has not proved so well in practice, as was expected. The author is not personally able to render judgment in this; theoretically the process is well considered. The same writer further makes remarks about the nature and solubility of the organic constituents of wood, which are very interesting and by which is shown the successive work of the leach. He says: "The organic constituents of the wood belong to several groups, as some of them are soluble in water and consequently can be removed from the wood by treating with water, while others are insoluble in water. To the former belong gum, vegetable albumen, tannins, coloring matter, etc., to the latter belongs the resins, balsams, etc. Lastly there is the incrusting matter or the lignin, which has been deposited in and upon the membranes of the cells and vessels and which is consequently most closely combined with the

cellulose. A wood fibre may therefore be conceived as built up with the cellulose as the elementary substance, penetrated with lignin, next with a covering layer of resins, etc., insoluble in water and finally a third layer, which mainly contains substances soluble in water. This composition justifies the conclusion that every layer protects more or less the one laying below, against the action of the solvents, and that removing the layers in reversed order must lay bare the cellulose. Now, as the outer layer is soluble in water, it is sufficient to treat the wood first with water or steam of such temperature, that no change of the lignin can take place. Because the resins dissolve in weak leaches, the application of such removes the second layer, while the lignin is treated with stronger leaches at higher temperatures. Upon this principle, Ungerer in Vienna has worked out a process of boiling, which must be considered the most perfect, because it treats the wood in succession with steam and leaches, the concentration and temperature of which are continuously being raised, whereby it at the same time the leach is worked to exhaustion and excellent fibres is produced."

This system shall be described more particularly in the next chapter. Here we have next to do with the leach and its preparation, which is very simple in the soda process, as soda and the other chemicals are simply dissolved in a tank, in which by means of a steam coil the liquid can be heated and then so diluted that the desired degree of concentration is obtained. But as soda is expensive, and as it would be extravagant to let it run to waste together with the spent leach the idea was conceived soon after soda-cellulose manufacturing was introduced, to evaporate the leach containing all the incrusting constituents of the wood fibre, and thus to regenerate the soda, whereby at the same time the otherwise inevitable contamination of the waters was avoided. Naturally the soda is not recovered pure, several combinations being formed, but it was discovered that the same action results from the intermediate product of the soda manufacture, the sulphate of soda as from the carbonate of soda. Dahl in Danzig, discovered this about 1883 and he first used a leach containing sulphate of soda, carbonate of soda, caustic soda and sulphide of soda. The leach is prepared from sulphate of soda and 23-25% of caustic lime, to which are added the salts re-

covered from former leaches. The spent leaches are concentrated by evaporation, strongly calcined and after all gases are driven off, pulled out of the furnace in the form of coke. The mass is then lixivated and the solution obtained serves to make new leach. To obtain it free from coal, the concentrated solution is heated in a furnace to dark redness. The resulting mass, assuming a reddish-brown color in cooling, is easily soluble in water and has about the following composition:

Sulphate of Sodium 16%
Carbonate of Sodium 50%
Caustic Soda (soda) 20%
Sulphide of Sodium 10%
Different other substances 4%

This composition varies considerably according to the wood treated, but the solving power of the leach is not much influenced. These salts recovered from the leach must be dissolved soon to avoid the action of the atmosphere. In the boiling and recovering, about 10 to 15% of the salts contained in the leach get lost, and must be replaced with sulphate of soda. From 85 to 90% of the recovered salts and 15 to 16% of sulphate of sodium, which has been boiled with 20 to 23% of caustic lime, yield a good leach. The quantity of the sulphate of soda treated with lime, and the quantity of lime itself vary with the estimated loss of the salts. At a loss of 10%, 10 kilos of sulphate of sodium and 20 kilos of lime are necessary for every 90 kilos of the recovered salts. At a loss of 15%, for every 85 kilos of the salts, 15 kilos sulphate of sodium and 23 kilos of lime have to be used; at a loss of 20%, for every 80 kilos of the salts, 20 kilos of sulphate of sodium and 25 kilos of lime. In general the resulting leach contains about 37% of sulphate of sodium, 8% of carbonate of sodium, 24% of caustic soda and 3% of sulphite of sodium. From the above it will be seen that the process described differs from the older process of boiling with caustic soda in that in preparing the leach, the caustic soda lost in boiling and recovering of the salts is replaced by sulphate of sodium, instead of by caustic soda, and the quantity of the caustic lime used is reduced from 45% to from 20 to 23%.

As in other lines of manufacture, competition has compelled economies, especially since sulphite-cellulose has made its appearance. In the course of time they substi-

tute the cheapest grades in the market for the expensive sulphates free from acid and iron, first used because iron and free sulphuric acid could, according to the manner in which the sulphate was employed in the different factories, either be made harmless in the form of sulphate of iron and sulphate of lime by the caustic process, or when worked with the stock for calcination in the fire. Several works, fortunately situated in the neighborhood of dynamite factories, went over to the use of the waste product of these factories; the acid sulphate of sodium. This salt being nothing else than sulphate of sodium with considerable percentage of free sulphuric acid, which, as already mentioned, can be removed by chemical process or even made useful. In general, however, this utilization of the acid sulphate in the manufacture of soda wood fibre is not a characteristic modification of the process of Dahle, which in the manufacture of soda-cellulose is now in general use. According to Dr. Frank this utilization of sulphuric acid can be done by adding chloride of sodium, consequently is utilized as sulphate of sodium. In the customary process of neutralizing with lime the sulphuric acid does but add a ballast of sulphate of calcium (gypsum), therefore neutralization with spent leach would be still better.

At this point, after concluding the chapter about the soda leaches and previous to the description of the processes and expedients for the recovery of the soda, it may be in place to mention that the name "sulphate-stuff" is really not correct, as the sulphate, e.g., the sulphate of sodium does not exercise the dissolving effect on the incrusting constituents, which is done by the carbonate of sodium and the sulphide of sodium while in the preparation of the leach is made first from the sulphate. The soda, which may also be produced from sulphate of sodium, made by the cellulose manufacturer himself by conversion. Therefore the designation, soda-cellulose, is the only correct one.

For this purpose formerly, evaporating furnaces were principally used, like those employed in the manufacture of soda. In Lunge's Handbook of the manufacture of soda such a furnace is illustrated, as reproduced in figures 18 and 19.

In this illustration *g* is the pan designed for evaporation, which is deep and supported by stone pillars, so that

the bottom of the pan is exposed in order to facilitate cooling off. At the left is the grate *a* on which the fire necessary for evaporation is maintained. The flames first spread over the fire-bridge, kept cool by the waterpipe *c*, then over the calcining sole *d*, over the somewhat higher placed sole *e*, and finally over the evaporating pan *g*, from where they are let into the top of the chimney. The solution makes its way oppositely to the fire; first it is evaporated in the pan, until solid parts separate out, then the mass is drawn out on the side upon the draining sieve *i*, below which the solution is let off into a reservoir and from there

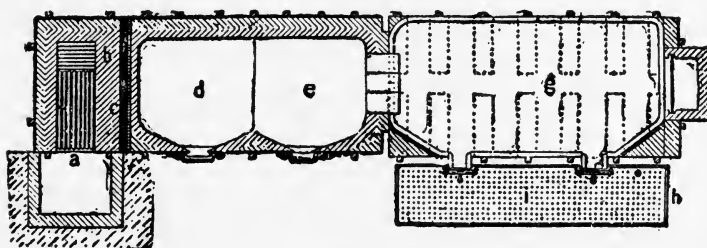
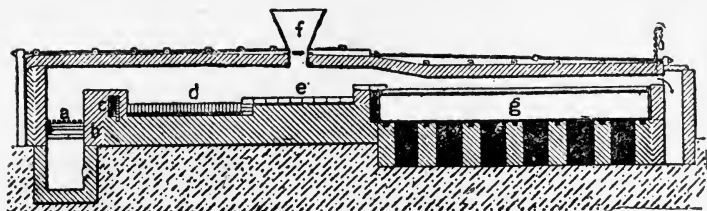

FIGURES 18 AND 19.

by means of a pump it is again charged into the pan, to be further evaporated. Through the funnel *f*, fixed over the first calcining sole, the solid residus are filled upon it, where the last of the water evaporates and after this is accomplished, it is by means of scrapers drawn into the compartment *d*, and there calcined. After this has been done sufficiently, the mass consisting of carbonate of sodium is pulled out from the chamber *d* at its side, and directly into iron wheelbarrows, by which the mass is again carried to the dissolving tanks, there dissolved and made caustic, to be used again in boiling wood.

Another evaporating furnace was constructed by Roeckner in Newcastle. Here the leach first flows into a cylindrical vessel lying horizontally and is there concentrated by boiling. The steam therein cooled gets into a condenser and as boiling water it runs into a reservoir. The concentrated leach flows through a pipe, fixed to the bottom of the vessel in an open pan on a lower level where it is further evaporated, and from there into a calcining furnace, situated below, where the complete conversion into soda takes place. From there, by means of rakes, the mass is pulled into the cooling chamber, arranged below. Here a current of air passes through the hot mass, assisting the combustion of the gases, which are passed into the fire-hearth serving the other parts. By this the odors, which appear, when the soda is simply discharged from the furnace and brought to another place to cool off are avoided.

To obviate the considerable wearing out of the expensive evaporating pans, with the present evaporating apparatus, Richard Schneider in Dresden, has constructed an evaporating tower, with movable drizzle faces, conveniently adjustable (D. R. P. No. 34392), which may be employed to advantage together with furnaces for the regeneration of soda. This furnace consists,—the plant of the gas generator and the chimney not considered, (it is a regenerative gas furnace)—of the firebox H, in which the ignition of the fuel gases takes place and which, according to construction, may be formed so that it may give off highly heated fire gases or highly heated air separate from each other or together. Further attached to the single or double calcining sole C, at the other end of it, set out with chamottstones like a regenerator, there is a short chamber R, which during the calcining process is contributing substantially, to obtain thorough combustion of all gases escaping from the calcining sole, and thus securing smokeless and odorless working. Next to the chamber R is situated somewhat higher, a quite deep tank D, serving as inspiring pan. Over D the evaporating tower E is erected, with its movable drizzle faces, which ought to have a declination of less than 30 degrees against the horizon. The number of the drizzle faces depends on the quantity of solution to be worked per unit of time.

Above C and R there are, for utilization of the radiant heat, a large tank A, from which the smaller tank B, put

up over the tower E is being fed by pulsometer. The space under C has been arranged for baking and cooling. Into this are pulled from C, through correspondingly constructed doors, with which C is provided, the red hot, but not yet deadbaked masses, which under this system do not need to be raked out in front of the furnace.

The products of combustion of part of the fuel gases,

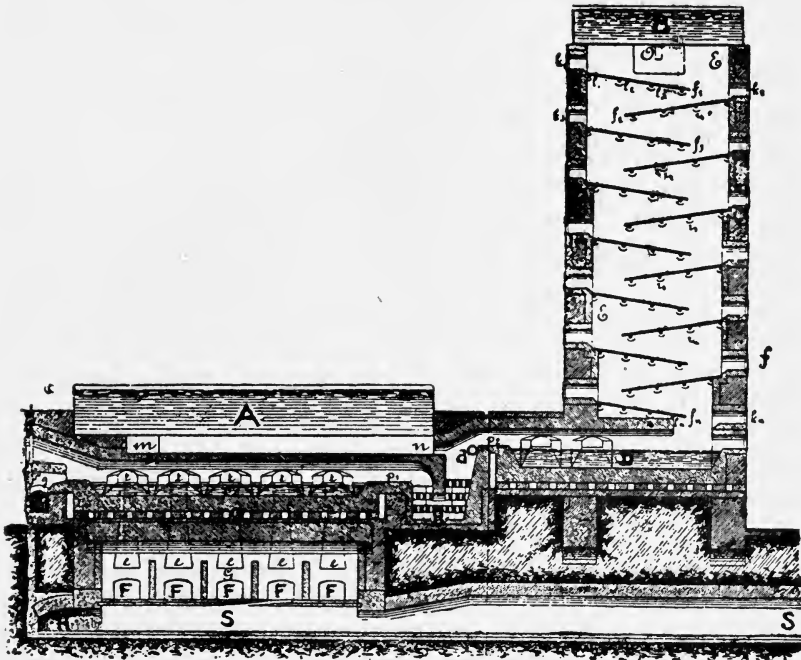

Fig. 20.

charging H, are carried off through the channel s to the chimney S. The part of the channel s under G is slightly vaulted, or still better covered with two layers of thin chamotte plates. This arrangement and construction of s is for the purpose of utilizing as far as possible the heat of passing products of combustion and to keep up and to quicken the calcining process of the masses dropped into G. The gases thereby evolved (empyreumatic gases), are

by special channels discharged to the fire-hearth and there burned up. The thoroughly calcined dead masses are then at regular intervals corresponding to the different charges, discharged from the different compartments of G through the doors F and turned over to further manipulations. There are further provided at m adjustable openings for the inlet of air, and at d for the inlet of the fuel gas. The air entering at m gets heated along the vault over C, and through openings n, it reaches p, there to either cause a perfect combustion of the gases coming from C or to burn the gas entering by d to increase at times the heat in D.

The leach to be worked is first run into the tank A, from there lifted to B and, drizzling down the tower in the manner described above and giving off water in the form of vapor, it reaches D, from where in a condensed state it is charged into C, where it is finished. The fire-gases coming from H, go the opposite way, as with other evaporating furnaces. The arrangement offers the advantage, that besides the saving of a pan, the total plant takes up much less space.

Herr Carl Keller had previously in the seventies, built a furnace for the recovery of the soda from straw-stuff leaches, in which the fire-gases were forced by means of a spray of superheated steam over pans arranged like shelves, one above the other. There the hearth and the calciner were under draught, while the back part of the furnace and the part used for concentration were working under a slight pressure of about 2 mm. water column. This arrangement permitted the fire-gases to be led slowly over a large evaporating surface, which would be possible only to a limited degree where the draught of a chimney alone was depended on, owing to the elastic steam formed in evaporation.

For completeness sake it may be mentioned, that an American patent, No. 388,284 by John F. Kennedy, is intended to make use of the heat still contained in the calcined residues, by arranging a common steam boiler, to produce steam by their radiant heat. Whether this arrangement has proved a radical success, is not known to the author.

Another arrangement for the production of soda, which has proved very successful in practice, is in operation in

the Cellulose factory Rannkem in Norway and is described by Herr Laur. W. Yensen in No. 11 of the *Papier Zeitung*, 1889, as follows: The regeneration of the salts, contained in the leaches is thus accomplished in three steps: First, Evaporation of the water until concentration of the leach of 30 degrees B in steam boilers, tubular boilers and pans, whereby the fire-gases are so led against the opposite directed current of the leach, that the fire-gases escaping into the box give off their heat until as low as 150 to 200°C. Second, inspissation of the concentrated leaches to muddy consistency by open fire in a fire-proof inspissation pan. Third, volatization of the incrustings while melting down the salts in a retort-like furnace, which is so connected with the inspissation pan, that the gases enter the main fire, there being burned up and so assisting in inspissating the leach. The evaporation starts in two steam boilers A, which are connected by a pipe d; the solution is pumped into the boiler through the pipes bb and remains there, until it has reached a certain concentration. The steam evolved in the boilers is in the domes D freed from the leach carried along, by arranging in each of them a sieve with pieces of iron thereon. The solution concentrated in the boilers is, after certain intervals, blown off through the blow-out pipe g and then through the pipe line h is run into the tubular boiler B.

A steam pipe r, leads the steam evolved in the further evaporation of the solution, from B to the drying cylinders of the paper machine, although the steam may be used for any other purpose. The heating of the tubular boiler is done with the steam which is evolved in the evaporation of the solution in the boiler A, and which gets into the heating tubes by the pipe R' from the dome D. Under normal conditions the solution of from 13 to 21 degrees B is evaporated down to 21 to 27 degrees B in the tubular boiler and then run off into the highest of the four evaporating pans C, which originally, set above and against each other, were so built in that the fire-gases, which were striking along the boiler A in the direction of the arrows, were now passing in the direction of the arrows over the lowest pan and further on, on their way to the chimney, over the three other pans. But the gases got cooled off too much and poor draught was the consequence; besides, the space below was needed for a smelting furnace, so the shelf fur-

nace was taken out, and the gases of combustion were passed between two pans filled with solution directly to the chimney. The solution is thus concentrated down to about 30 degrees B and from the lowest pan through a line of pipe led off into the inspissating tank E. The inspissating tank is a low vaulted compartment, lined with fire-proof material, in which the solution stands as high as the upper edge of the fire-bridge. The plane-grate fire hearth F produces a flame, which by natural draught strikes into the tank and is forced by the vault to strike closely along the solution, whereby the water is further evaporated. Through openings in the long wall of the tank, the solution is continuously stirred while inspissating and thus its dessication is furthered. When the solution has become as thick as heavy mud, the fire in F is dumped and the mass pulled out through the openings. It is then thrown into the retort-like smelting furnace L1, where by firing in the box N, the evaporation of the remaining water, the continued combustion of the incrustations, and the melting down of the salts takes place. The fire-gases thus make their way as follows: The gases from L, fig. 21, mix with those from F, strike along the inspissating pan E and mix with the flames of the smelting furnace L1, fig. 22. The hot fire-gases now strike along both boilers, from back to front, there separate, returning through two fire canals and again coming together strike over the pan C. The fire-gases are on their way deprived of such an amount of heat, that they escape to the chimney with a temperature not higher than necessary for the maintenance of the draught. In comparison of the arrangements in use in Europe, the one in question offers considerable saving in fuel, by thoroughly utilizing the fire-gases.

With 1 kilo of coal it is possible to recover 25 kilos pure dessicated salt and yet to have enough steam to dry 15 kilos of wood fibre.

The same Herr Yensen, who has accepted for years the above described plant as satisfactory in practice, much prefers an American patent, which Homer T. Yargan has obtained for a process of regeneration of soda and which is also protected in Germany by patent No. 42,592. In No. 100, Vol. 1888, of the *Papier Zeitung*, this device is described as follows: "Here the inspissation is not effect-

FIGURES 21 AND 22.

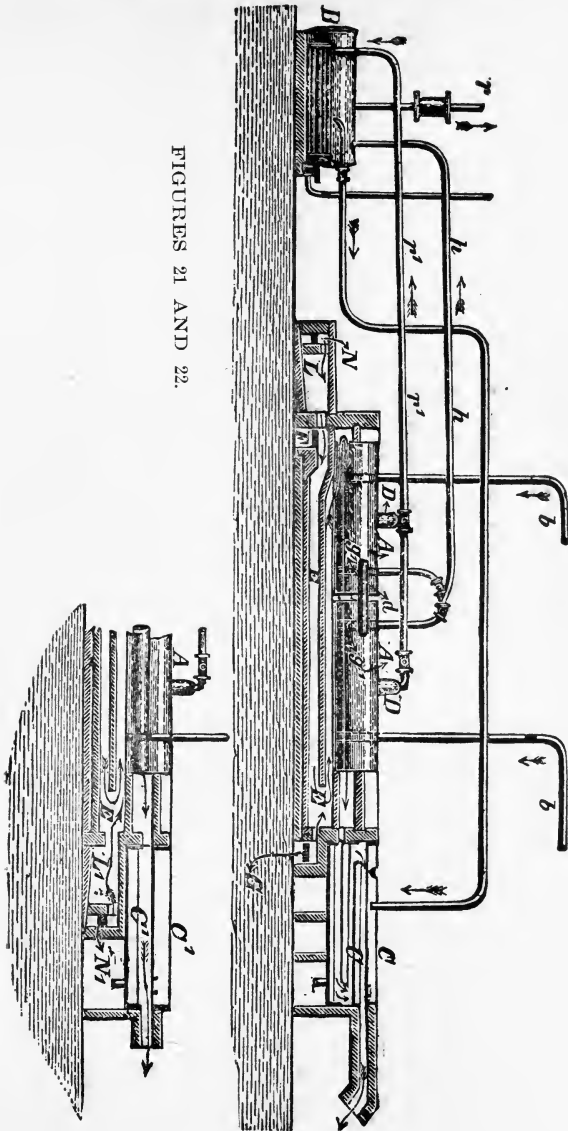

ed by direct firing, but by steam, whereby, it is claimed, the expense for fuel is decreased. Figs. 23 and 24 show the arrangement in the side view and in the plane. The concentration is carried on in three adjoining cylinders. The middle parts of the same, H'' H''' H''', are closed by sectional walls against the extremities L L' L'', and A, B, C. The extremities are connected with each other by a number of narrow pipes, which end in the sectional walls and countersect the middle parts. The spent leach to be concentrated is forced by means of a pump through the pipe O', run into the cylinders at L and flows through the narrow pipes into the other end A. Through the pipe K steam is admitted into the middle part H', which sur-

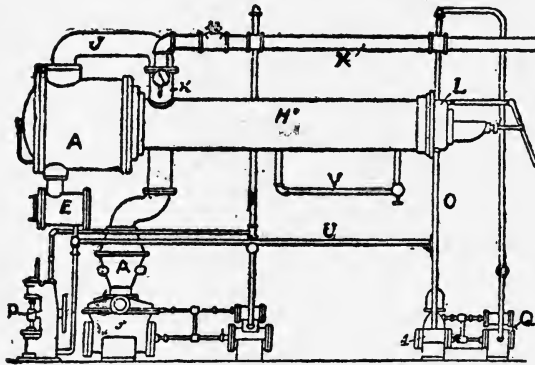

Fig. 23.

rounds the pipes and gives off its heat through the walls of the pipes to the leach. The water of condensation is continuously let off through the pipe V. The heated leach runs into the chamber A, gives off a considerable quantity of steam and flows in a thickened condition into the chamber E below A, and is forced through pipe U into L' fig 24, from whence again, as described above, it flows through narrow pipes to the end of the cylinder at B, and from there through pipe U into L'' and from L'' into C. The steam escaping from the leach in the cylinder at A, passes through pipe H into the second middle part H'', and here, as in H'' the live steam works through the walls of the narrow pipes upon the leach. The water of condensation is again carried off through pipe V. The steam

escaping from the leach in chamber B enters through the pipe J into the third middle chamber H''', to work here in the same manner, as stated before. The steam which continues escaping from the leach in the chamber C is, through the pipe J, drawn into the condenser W of the vacuum pump, while the concentrated leach is carried off by the pump P.

The vacuum produced by the pump O acts on all three cylinders in diminishing degree, so that in the chamber A it is at least and in chamber C greatest.

As will be seen from the above, fresh steam is let only into the first cylinder H'', while in the other, evaporation

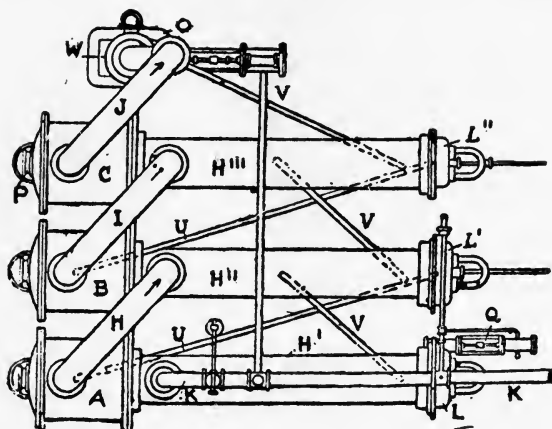

Fig. 24.

is effected by the waste of steam of the leaches. The quantity of steam used will for this reason be small, as one triple-effect Yargan can, for instance, evaporate 15 kilos of water with 1 kilo of coal. The leach is by the Yargan evaporator concentrated to 40 degrees B; the whole of the soda-regeneration is far cleaner than is generally found, besides the attendance of but ten men altogether is necessary in 24 hours to recover the soda for twenty tons of wood fibre, while in the Rankeim apparatus, for instance, for eight tons, twenty men were needed. The Yargan apparatus has already proved eminently successful in several American factories. In one of them, for instance, 18 tons

of coal were saved per day as compared with the former method. The very high price of the complete plant is, at present at least, a drawback to its more extensive introduction in Germany.

Contrary to the soda process just described, the sulphite process is based on treating the wood with acids, and lately, indeed, with sulphurous acid only, consisting in the combination of one part of sulphur and two parts of oxygen. It is a gas of strong and pungent smell, which mixed with air, impedes breathing, but is not so absolutely injurious to the human system as one would think, on the contrary, the inhalation of the gas, properly diluted with air and with due precautions, has lately been recommended for consumption, and is for this purpose already employed practically, for instance at the Augusta Victoria Bath in Wiesbaden.

At low temperature or high pressure the sulphurous acid gas may be transformed into the liquid state. Water absorbs sulphurous acid gas in large quantities, as water itself is also attracted by it from the air. Upon this readiness to combine with water depends its practical employment, because an aqueous solution is the easiest to handle. The American Tilghman, as stated in the chronological table cited at the beginning, in 1866 first recommended sulphurous acid for dissolving the incrustations, and he obtained upon a process embodying this feature, the American patent being dated October 26, 1867, and the English March 31, 1867. In the American patent the entire method of manufacturing is very exactly and copiously described, while the *Papier Zeitung* in 1884, the later practical experiments on a large scale are described. Notwithstanding the fact that he had not worked out his invention as much as would have been desirable, he turned his energies to other ideas, so that the promising process of producing Cellulose by means of sulphite solution did not rapidly come into general use. Succeeding Tilghman, Ekman, in Bergvik, Sweden, also discovered a process of producing Cellulose by sulphurous acid and he was the first one, who after finishing his experiments, made on a large scale a product fit for use, he first manufacturing secretly, and did not take out a patent until July 13, 1881. In Germany, however, he was preceded by Professor Alexander Mitscherlich, who obtained patents not only on the

chemical process of producing Cellulose from wood by sulphite leach, but also on the different parts of the necessary plant. He was very successful in making a great number of contracts with those paper manufacturers who bought of him his process and who besides obtained the privilege of exclusive rights within certain territories. In consequence of a legal suit, the principal part of Mitscherlich's patent No. 4,179 was annulled in 1884 by the Imperial Court, when it became known that the patent of Tilghman was much older. Besides this, beginning from the year 1893, a vigorous polemic has arisen in the *Papier Zeitung* as to whether Mitscherlich or C. D. Ekman had first made saleable Cellulose on a large scale, which in the end was decided in favor of the latter. Therefore the note contained in the first edition of this book, that Professor Alexander Mitscherlich was the real father of practical Cellulose manufacture, can to-day no longer be completely sustained, although great credit is due him on account of the practical execution of his ideas and the introduction in business of the process named after him.

We will first consider how the sulphite leach according to Mitscherlich is made. The sulphurous acid is produced by burning sulphur or compounds containing sulphur. Among the latter is the comparatively cheap pyrite which is composed of about nearly one part of sulphur and one part of iron. When sulphur can be obtained cheaply i. e., cheaper than three times as much of the pyrite would amount to one would decide for the use of sulphur, in the combustion of which a direct loss can hardly happen, while the pyrite after roasting shows at least 4% unburned sulphur inside the different pieces, and the loss sometimes reaches 10%. In using solid sulphur the furnace may be of simple construction. A chamber of mason work, the bottom of which is formed by a heavy iron plate, will answer; some low iron partitions divide the combustion chamber into several compartments, every one of which is accessible from the outside through doors, so that filling and cleaning can be done alternately, while working. The furnace is also covered over with an iron plate, which is cooled by water, so that during the process no sulphur can escape unburned. The controlling and regulation of the air supply is done through small shutters arranged in the doors.

Very often, however, pyrite must be used alone. This

must be broken into pieces with the hammer as uniformly as possible of about the size of a nut. There are stone breaking machines for this purpose, but they are supposed to give too much clear waste and this must be avoided. When in crushing enough of the fine pyrite has accumulated, it may be made use of by mixing it with loam and forming into small balls, which after being thoroughly dried on the furnace, may be charged into the furnace along with the good material, without danger of stopping the grate. It should be mentioned at this point, that Herr Maletra has constructed a plate-furnace, which is employed with advantage principally for roasting fine pyrite and especially dust.

The broken pyrite before using has to be stored in a place as warm and dry as possible, but in the room where the furnace stands. Such pyrite furnace is illustrated in figs. 25, 26 and 27. The furnace is almost quadratic, the inside laid out with Chamotte brick, about 1.5 meters wide, spanned over by a flat Chamotte vault, with an opening in its zenith for the outlet of gases, which next enter a space between the first vault and another one spanned over the first one. Because, as a rule according to the extent of the works, three, four, or more pyrite furnaces are placed side by side, or still better, with their backs against each other, not all of which, however, are worked at the same time, they must be connected with each other and with the different towers later on described. This is done by arranging above the furnace two canals, the one of which is by the opening A, the other by the opening B connected with the interspaces mentioned. Both are closed by peculiarly constructed valves, similar to water sealed valves, only that in this case on account of the heat, not water, but sand, or fine pyrite is employed as a means for sealing. The second vault mentioned also serves the purpose of protecting the inner one against cooling off. About one-half meter from the floor is a grate, consisting of single, strong, square bars, arranged quite close together, which by means of a key fitted to the front end can be turned, and thus during roasting, the cleaning of the grate, i. e., the falling through of the slake is possible. The front opening through which the turning of the grate bars as well as the pulling out of the finished pyrite is performed, and likewise the fire door itself, which serves

for the feeding of fresh pyrite are provided with well-fitting doors, which as a rule are luted besides with loam.

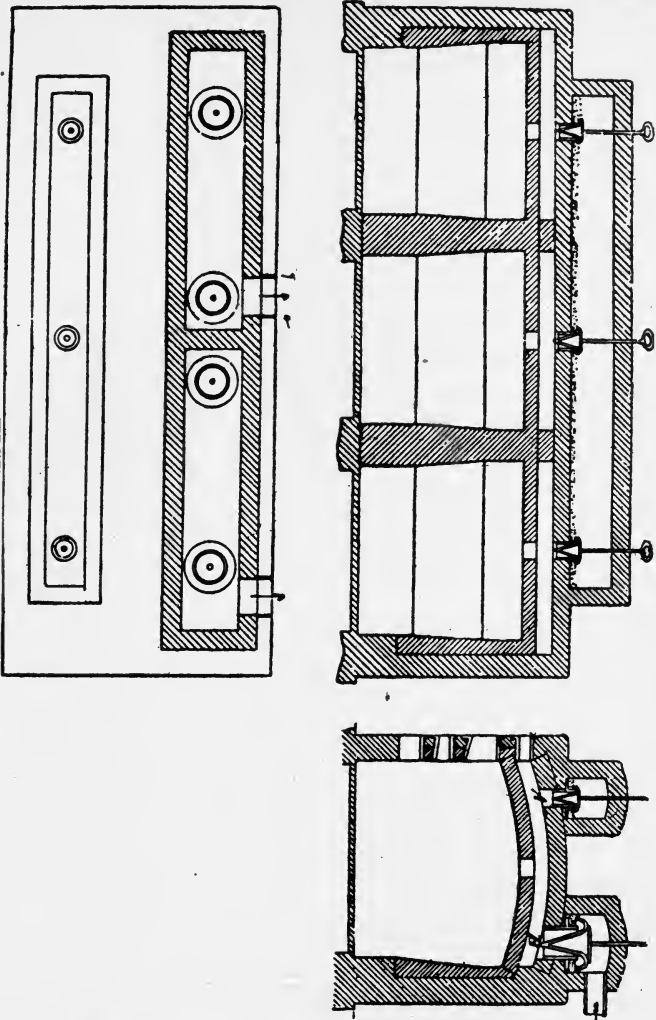

FIGURES 25, 26, 27.

They are also provided with a small hole, closed with a shutter or glass plate, through which the process is con-

struction may be observed at any time. This process after the furnace has once been started, goes on in the following manner: To the burning pyrite, kept at light red heat, enters atmospheric air, the oxygen of which combines with the iron from oxide of iron, and with the sulphur to form sulphurdioxide or sulphurous acid. Hence the regulating has to be managed so that not too much air enters, but enough to maintain the furnace at intense red heat. Care must also be taken that the pieces of pyrite all get thoroughly burned through, so that only iron oxide and not part of the sulphur is thrown on the slake-pile, what eventually would amount to considerable loss. Insufficient air supply has besides the disadvantage, that sometimes separation of uncombined sulphur takes place, the so-called sublimation, which can be of much damage in the later digesting process. In order to obtain in the next manipulation a most concentrated solution of sulphurous acid, the gases leaving the pyrite furnace, must contain as much sulphurous acid as possible and this can be only when the air supply is limited to the least necessary quantity, when the gases themselves possess a temperature as low as possible. Therefore they are not let directly into the tower, which is necessary in the making of leaches according to the system of Mitscherlich, but they are cooled off by leading them in heavy pipes, up to about two-thirds or three-quarters of the height and down again to the foot of the tower. For this reason a less strong solution always results in the summer months than in winter, which must be called a disadvantage in regard to uniform working. This may be somewhat remedied by continuously letting water drizzle down the outside of the before mentioned cooling pipe, though this is far less effective than the cold of the winter.

What influence the temperature has on the production of the leach can easily be seen from the following little table, showing the capacity of the water for absorption at different degrees of temperature:

Water of	2°	4°	6°	8°	10°	12°	14°	16°	18°
absorbs	75	70	65	61	57	53	49	45	42
cubic centimeters of sulphurous acid gas.									

At the above mentioned ascending pipe, near the furnace two small branches (T's) are advantageously arranged, which are connected by a glass tube, like the water-

indicator on steam boilers, so that the circulation of the gases, coming from the pyrite furnace, can be observed. When sublimation has taken place and consequently sulphur is untainted in the gases, a yellow coloration will show upon the glass and then better draft must at once be secured i. e., some air must be admitted. To transform the gaseous sulphurous acid into the aqueous solution, mentioned before, it is necessary to lead the gas against a fine shower of water; the aqueous sulphurous acid so obtained is, however, very unevenly composed and little suited for the subsequent process of digesting. For this reason it is preferred to use combinations with bases, which can be easily stored, and for practical reasons the comparatively cheap lime-stone, easily obtainable and sometimes also magnesite, were chosen. Mitscherlich recommends lime of rather porous condition, so that a large surface is presented, which, however, must not be too soft, as it would then dissolve too quickly, become muddy and cause clogging of the tower. The lime-stone is broken up into pieces of about 100 m. m. diameter. Other factories, working the same system, do not use tufa, but dolomite and jura lime, and, as they claim, get further with them, on account of their greater hardness. Carl Kellner first used dolomite and had the process patented.

The tower, which is the characteristic sign of most Cellulose works, is constructed in the following manner:

Fig. 28 shows an outside sketch of it, and fig. 29 the ground plan. Upon a strong square foundation are built two, and sometimes four or more reservoirs of masonry, open at the top, over which are set the wooden towers. These towers of 30 to 35 meters in height are formed by setting single barrels, properly cylindrical tubes of best resinous pine, bound by iron hoops, on top of each other, packing the joints with waste and coating the whole heavily with tar. Because the lower parts have to stand great pressure on account of the lime charge, representing according to the width (as a rule one meter) and height of the tower a weight of over 1,000 C, the thickness of the lower walls must be made heavier and also the number of hoops must be increased where the dimensions are greater. Directly over the stone reservoirs, near the top of which the gases of combustion enter from the pyrite furnaces and at the bottom of which the finished aqueous

solution is let into the leach reservoirs, is laid a heavy grate of oak, the single beams of which are narrower at the tower side. That the great weight of the lime shall not rest thereupon alone, two other heavy beams go square through the tower, being supported from the outside. At the upper end of each tower is a water reservoir, fed from below by a pump, from which a stream of water, regulated, as required by a cock, can be discharged on the lime. It must also be made possible by means of a valve or otherwise, to let a larger quantity of water even to the whole contents of the reservoir run down at once, when it becomes necessary to rinse out the tower. Close below the water tank is a side opening through which the lime is filled in. This must be made so that it may be securely closed and there must also be some smaller openings arranged at different heights. The different towers are surrounded and held together by a strong frame work, divided in stories, connected by stairs and roofed over on top, so the whole forms a single ball tower, which offering a large surface to the wind, must certainly be well anchored to the ground by wire ropes. In the uppermost story there is generally a balcony from which the lime buckets, previously hoisted up by a windlass, are carried to the fill-hole. Where power is convenient it is better to have the hoisting done by a mechanical elevator. For practical reasons it is well not to delay the first filling of the tower until it is finished, as the grate suffers, when the lumps of lime fall from so high a distance; the lime itself gets crumbled and thus in the beginning might cause clogging, but to charge the different sections as the tower is building up. There has but to be mentioned that the ascending iron pipe at its upper end, where it forms the ell, is provided with a cover, which must be well luted. This cover is opened, when a newly started furnace is getting warmed up and is not closed until the pyrite is burning with a blue flame, and the charge is consequently in good order. After that the gaseous sulphurous acid is permitted to enter the tower, drawing upwards against the water, flowing over the lime.

Along the walls of the tower there will naturally be large spaces, not filled out with lime, also the water will not everywhere evenly wet them and thus the upward drawn sulphurous acid would become unequally absorbed.

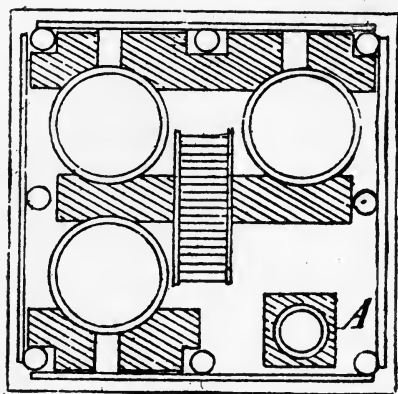

Fig. 29.

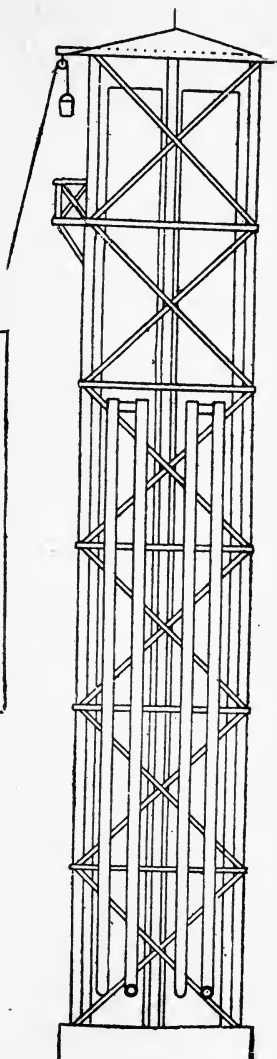

Fig. 28.

To prevent this, several protruding rings are fixed to the walls, inside of the tower, against which the gases must strike and by which also the water, which might otherwise run down the walls at certain places only, is turned off towards the centre of the lime charge. By the contact of the sulphurous acid with the lime taking place on the long run through the tower, sulphite of lime is next formed, whereby the carbonic acid of the lime is set free. Then the sulphurous acid is dissolved by the water and this again dissolves the sulphite of lime, which is soluble in water, only with difficulty, and thus bisulphite of lime is formed. As already mentioned, the temperature is of great importance in the chemical process, and also the supply of air in the process of combustion; this, therefore and the quantity of water running down must always be taken in consideration, because also on this depends the concentration of the leach. When too much water is admitted, the resulting product, the aqueous solution of bisulphite of lime, would be too weak. From the stone reservoirs in the foundation of the tower, this solution is now let off through a lead pipe into large wooden tanks, which are best placed so high, that afterwards the leach can be run through a line of pipes directly into the digester. Where the local conditions do not permit this, it is best to use a reservoir of mason work, well covered, from which the leach, when needed, can be pumped to the digesters. In this case it is advisable to first catch the leach in a barrel, because it is necessary during the concentration of the leach to have it measured quite often with the areometer by the man employed at the pyrite furnace, and also by the technical officials, so that when the leach comes too weak, the fault can at once be remedied. The average strength is 4 1-2 to 5° B in summer, but in winter 7° and more.

If the preparation of the leach has gone satisfactory, the areometer indicates the proper strength of the leach in bisulphite of lime; but when sublimation has taken place, polythionic acid is formed in the tower (according to D. Frank, this is impossible) the compounds of which are harmful in the digesting process, while in the leach they are estimated wrongly as bisulphite of lime, consequently the concentration is measured stronger than it is in fact.

In this process there has repeatedly occurred a clogging of the tower; it takes place after one or two days, some

times oftener, when the lime partially dissolved by the acid and washed together by the water accumulates below on the grate, or at any other place, and renders the passing of the gases impossible. Draft is then wanting and the furnaces smoke, i. e., the gases come out at the joints. The other tower must then be put to work at once. The impediment may be removed by opening a door arranged directly above the grate, pulling out the lowest layer of stones and rinsing the tower once or several times. The same result may be achieved by causing the whole lime charge to slide, when the pieces change their position and the working order is restored. As soon as the lime charge in the tower has somewhat settled, new lime must be added. The pieces pulled out in cleaning the tower, if not too small, and after being well rinsed, may be mixed with fresh lime and filled in again.

For every plant, besides the towers just described, another smaller one, a so-called "drive-over-tower," is necessary, which is filled with the waste pieces of lime. This tower has a smaller diameter, and need not be as high as the others. It often consists of kerosene or oil barrels, set one above the other. In the sketch in fig. 29 it is marked with A. It is provided with grate and water arrangement like the other towers and is only used when an operation of digesting has been finished and the sulphurous acid gas, under pressure during boiling, must be blown off. The digester is connected with the small tower by a lead pipe. As soon as the water in this tower has arrived at the lowest part, the blow-off valve of the boiler is opened; the gaseous sulphurous acid rushes against the water and as long as the blowing off continues, forms a strong leach of about 12°, which often very much increases the concentration of the leach already in the basin.

In place of the high towers recommended by Mitscherlich, which are certainly the cause of many inconveniences, but which must be high, because the sulphurous acid requires much time to decompose the carbonates and to transform them into sulphites. Later on two towers were recommended, which are also quite satisfactory, when magnesite is used instead of lime. The tower need then to be but five to six meters high. Professor Hager in "Fabrication des Papiers," page 203, writes in regard to this as follows: The ball towers cause a multitude of discomforts

and uncertainties in working, not only because of the hoisting of the raw material to such a considerable height, but mainly also for the reason that on account of the great weight the lower pieces, already become softened, get crumbled and render difficult the ascent of the acid gas. Because in addition to this tall towers are expensive to build on account of the foundation, etc., it has been recommended to build in place of one high tower several low ones, for instance of six to eight meters high, adjoining each other and connected by pipe lines in such manner, that the acid not absorbed in one tower, is carried to the next one, and so on. But even this arrangement has its disadvantages, as in this manner, if the most careful regulation of the water supply is not absorbed, sulphite solutions of much varying concentration are obtained, because in the last tower but little acid is left for absorption. But as time for action can be procured for the gas by giving great square dimensions to the tower, it seems well considered to employ, instead of tall and narrow towers, low and wide ones of a shape deviating from the cylindrical; especially when it is considered that a saturated sulphite solution is best obtained by successive strengthening up, and by the meeting of unweakened gas with the sulphite, immediately before leaving the tower. For this purpose, at the point, where the gas first comes in contact with the material, the tower should not be wide, but above this point it should gradually become wider to give the gas much time for action, and should then become narrow again towards the top, to increase the velocity of the gas in proportion to its decreasing strength.

The tower built on this principle, illustrated by fig. 30 consists of two cones, the lower one inverted so that they are joined at their greatest diameter, which construction offers the advantage that with less height a considerable charge is possible while the walls of the lower cone form a support for the raw material, which now settles down as it gets dissolved, without danger of clogging of the drain-holes, which are arranged at b, and which widen towards the lower side. In such manner, with a tower of but about 7 meters total height, a capacity of 7.5 cubic meters is gained, when the dimensions in the proportion as given in the sketch, are followed. In the sketch can also be seen the inlet pipe for

the gases at a, the reticulate vault at b, the opening at c, for the charging of the raw material, which can be closely shut by an asphalted or annealed iron plate, the outlet pipe for the gases at d, and the sprinkling arrangement at e, with the water supply pipe at r. The vessel A into which the sulphite solution is running from O, is practically arranged in the vault G, outside of the axis of the tower, so that by removing the cover D, it can be cleaned of the undissolved particles of earth carried along and accumulating there. The emptying is either done through a lead pipe,

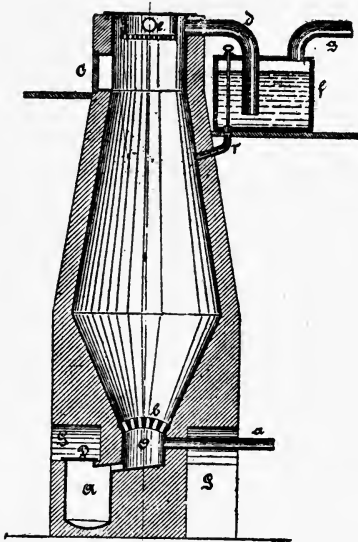

Fig. 30.

with a stop, or by a lead syphon. It is necessary to take care that the gas is completely absorbed on account of its damaging influence on vegetation and to let the air, coming from the tower, before it escapes into the atmosphere, pass through a mass, which absorbs the rest of the acid. For this purpose milk of lime or a soda solution is used; which is conformingly kept in a vessel placed at f, which can be hermetically closed. Into this the air from the tower enters through the pipe r, and after circulating through the solution leaves through the pipe g. After the

solution has become saturated, it can be directly let through pipe r into the tower, when making sulphite of lime. But if soda lye is contained in tank f, the sodium sulphite obtained is filled into glass vessels to be used as antichlor. To prevent damaging the inside lead lining of the tower, which is easily done when filling in the raw material, it is advisable to cover the lower cone with wooden slats, which also form gutters, permitting the sulphite solution to run off. It will answer, however, if instead of this arrangement the walls of the tower are protected by a coating of tar or asphalt. Whether practical experiments have been made according to this proposition is not known to the author.

Another method for the preparaton of sulphite leach, in which, however, the tower system is also employed, is the one according to the process of Ritter-Kellner. Herr Kellner has, according to his own personal statement, by accident indeed, but independent of Mitscherlich, discovered the most profitable application of sulphurous acid in the manufacture of cellulose, and so perfected it, that at present a greater number of the cellulose manufacturers work according to his instructions (which, however, have been amended by some in many directions) and manufacture a product, which in certain respects indeed differs from Mitscherlich cellulose, but which is excellent.

In Hoyer's work, page 214, the schematic drawing of this system, as taken from the French patent No. 157,754, is illustrated, as far as the leach making is concerned, and the following description is given: The making up of the sulphite is carried on in a circular run, beginning with the solution of the sulphite of lime in weak sulphuric acid, untainted in the tank A, running into tank D through pipe a, and on its way passing an injector at B, to draw along sulphurous acid gas, purified and cooled, through the pipe R, connected with the sulphur burner and thus saturated reaching tank D, charged with lime stone. In this tank is a false bottom, below which the sulphite solution accumulates, which by a pump P, is forced up into tank A, and kept in circulation, until it has reached the proper strength, to be then let off through the leaden faucet h. The carbonic acid liberated from the carbonate of lime in D, and the unabsorbed sulphurous acid and finally the air, coming from the sulphur and pyrite furnaces, reach partially the

water tank G, through the pipe R'', and its branch R'', and partially enter again into circulation, drawn up by the injector B through pipe R. As the end n of pipe R'', is perforated and laying in the water tank C, the rest of the sulphurous acid is absorbed by the water, while air and carbonic acid go off free. The water contained in C is then through the pipe b, provided with a valve for regulating and the injector pipe a carried to the absorption apparatus and used to dissolve the sulphite. According to another ar-

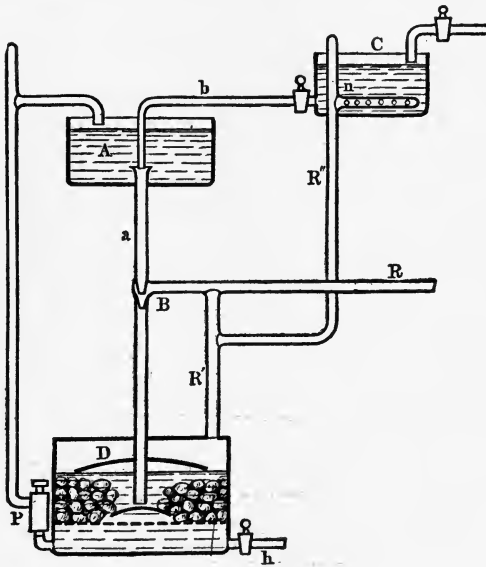

Fig. 31.

rangement (fig. 32) towers are also used and in such manner, that the sulphurous acid gas is drawn from the furnace by a steam injector and first carried to a large low horizontal chamber A, to get rid there of the dust carried along and to cool off, to which purpose the chamber is provided with partition walls, forming a labyrinth and covered by a tank B, in which is cold water. Then the gas passes through a coil C and enters in the ordinary way, into common towers I and II, filled with lime stone. Above the first tower I there is a tank D, into which is pumped from E the weak sul-

phite solution, obtained in the tower II and run into tank E, to be thus repeatedly exposed to the gas, by drizzling down this tower instead of water. But over the second tower a water reservoir F, is arranged, from which a shower of water runs down the tower II. To bring into circulation again the sulphurous acid not absorbed in the tower I, there is a connection made between both towers by a pipe r, through which the gas accumulated in the upper space of

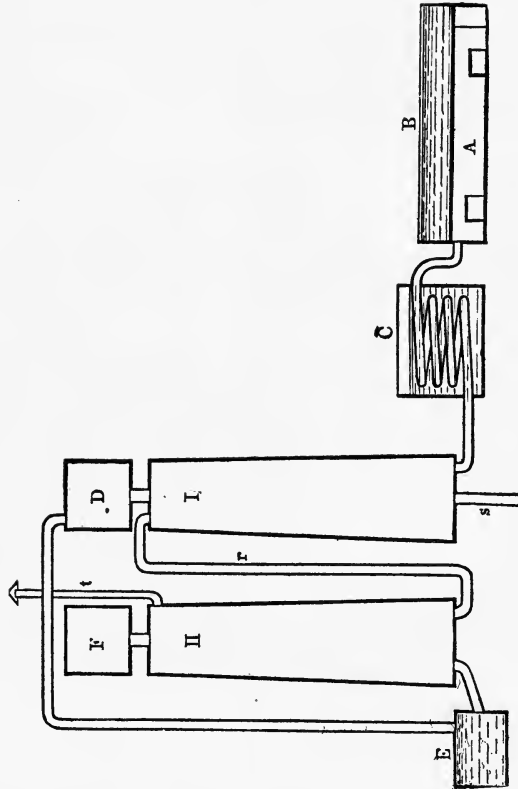

Fig. 32.

tower I gets into the lower part of tower II. Through the pipe s the concentrated solution flows into cisterns, and through pipe t, carbonic acid, air, etc., enter the open atmosphere.

One can see from the description, that the preparation of

leach, according to this system, is much similar to the Mitscherlich system, but in some respects appears much more rational, because by connecting two towers (which do not need to be very high) and arranging some pipes, besides pump and injector, a circulation is produced, by means of which a more equal concentration of the leach can be obtained, more easily and safely, which in regard to the subsequent process of digestion, must be considered an advantage.

Since the appearance of the first edition of this book the author has by personal observation in factories in Saxony and Bohemia, become extensively acquainted with the sulphite process according to Ritter-Kellner.

The leach plant, according to Kellner, as carried out in practice, is illustrated in fig. 33 and 34, as contained in set 1894, page 2,683, of the *Papier Zeitung*. This plant represented on a scale of 1:200, consists of two or more wooden towers or saturation tubes I and II, built vertically one next to the other, which are connected by the stone ware pipe S.

The filling material rests on grates, A in fig. 33, and is to be selected according to the nature of combinations to be made. It is recommended in the Kellner method, to fill the towers either with Dolomite in order to produce a doublesalt of acid-sulphite lime-magnesia or with carbonate of lime to make lime bisulphite.

Above these towers are the tanks T1 and T2, of which T1 is filled with fresh water and T2 with the solution from tower I. The outlet from these tanks into the overflow cups U below is regulated by an arrangement adjustable from below. The overflow cups also serve to distribute the sprinkling of the pieces of lime uniformly and offer the advantage that they do not easily get clogged up like sprays and distributing pipes. M1 and M2 are vessels of brass in which the concentration and quality of the solutions running out of the towers I and II are measured.

The sulphurous acid gas, coming from the sulphur acid pyrite furnaces runs in the direction of the arrows through the sublimatory K, and is drawn off by the injector D and blown through the cooling pipes D1. These are laid in a cistern, into which water is flowing from pipe l. At the other end just as much water is running off through the canal l1. The well cooled gases then enter the tower

I from below up to E1, spread along the stones in there, sprinkled with water from above, find their exit above at E2, a mixture of sulphurous acid gas, carbonic acid, nitrogen and air and are carried downwards through the stone-ware pipe S, until at E3 they enter the tower II there to as-

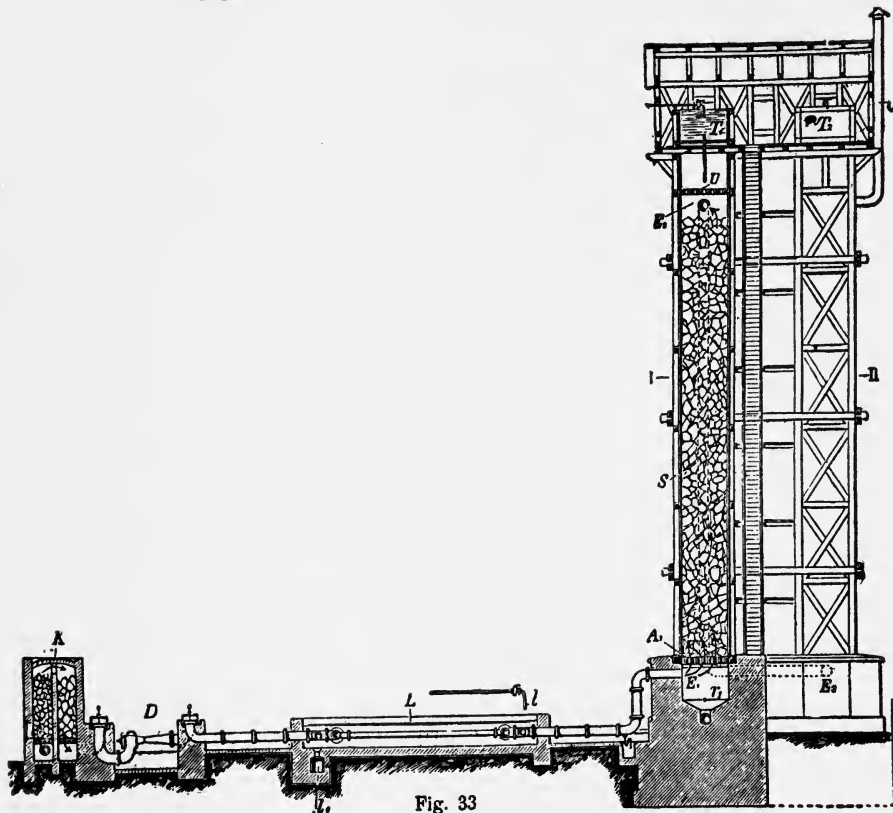

Fig. 33

cent again and to be completely absorbed. The unabsorbed gases, like nitrogen carbonic acid and air escape through pipe C into the open air.

The sublimatory K is a low tower, tightly closed, by a partition divided into two chambers. These chambers are filled with non-corrosive material, like pieces of brick, basalt stone or cake, which rest on grates and offer a large

surface to the sulphurous acid gas passing through for the disposition of the sublimed sulphur. In the wall trap

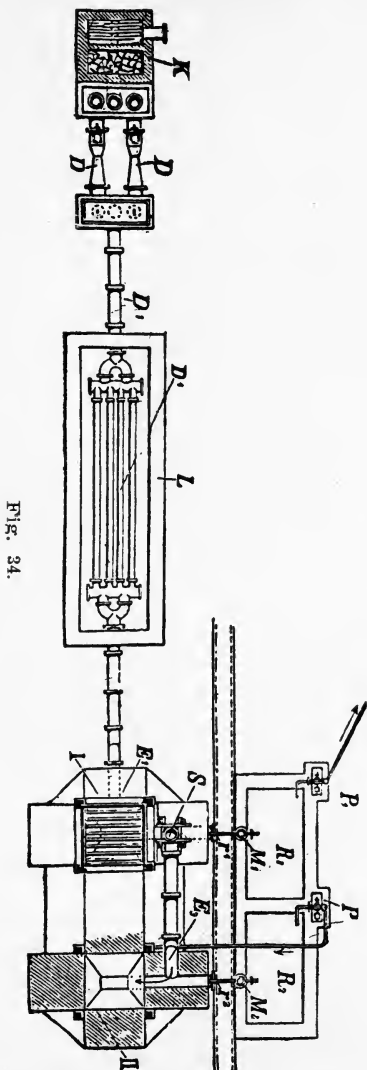

FIG. 34.

doors and others for cleaning are provided and it is of

advantage to have the covers consist of pans, which are cooled with water circulating through and cool off the gas passing through the chamber.

While the gases are circulating as described, water is let into the tower II from above, i. e., opposite the entering of the gases. It sprinkles the limestones, leaves the tower at r2 and runs as weak solution through pipe r2 and measuring vessel M2 into the tank R2; from this it is forced by the pump P into the upper tank T of tower I, from there it runs into the tower sprinkling its charge and leaves it, as finished leach, to run off through pipe r1 and measuring vessel M1 into the tank R. A second pump P1 forces the leach from there to the digesters.

Later Henry Kellner designed and installed several other methods of preparing leach. In a large German factory for instance he draws the sulphurous acid from the pyrite furnaces, forces it through a wash vessel and then through four wooden tanks, placed one above the other, in which are limestones and which are filled with water, which, following the law of gravitation, flows from one tank into the other and runs off below as finished leach. On page 2,714 set 1894 of the *Papier Zeitung* is described and in fig. 35 and 36 are here illustrated, such a battery of tanks, as working advantageously in Waldorf near Mannheim, the largest cellulose works of the world. This tank method depends on absorption of the masses and consists in forcing the purified and cooled gases by a compressor through the tanks, containing water and limestone. The solution runs from one tank into the other. The tanks I to V are so arranged that the solution therein contained can, through the connecting pipes w2 and w5, provided with valves, flow into the next one, until reaching V. The water flows through pipe W1 into tank I, which like II, 111 and IV is provided with a perforated false bottom on which the limestone charge rests. The sulphurous acid gas coming from the compressor, consequently under pressure enters through pipe g, into the lowest tank V, which receives the solution from tank IV, but does not have a false bottom nor a limestone charge. The acid not absorbed by this solution goes through the lead pipe g5 into the coil under the false bottom of tank IV through the openings of which it is evenly distributed over the tank. Likewise, the unabsorbed acid goes through pipes g4, g3, g2 until

reaching tank I, from where any remaining gas is again carried off through pipe g1. The gas pipes, g5 and g4,

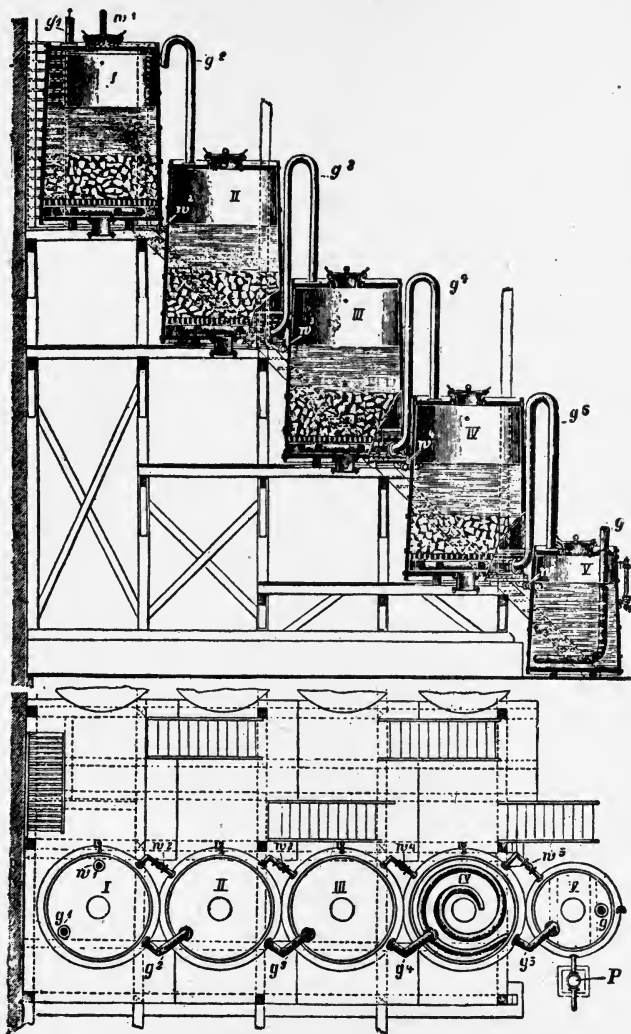

Figures 35 and 36.

are carried as high as shown in the sketch, in order that

no liquids from the higher tanks can run into the lower ones. When the plant is managed rightly nothing but air devoid of acid, should leave here, as it should be absorbed by the liquid, through which it is circulated. The solution arriving in V, there takes up sulphurous acid only, but no lime, and runs off through the leach measure P. Each tank is provided with a manhole of hard lead and a gauge glass. Stairs facilitate the access to all parts.

In American factories he has further introduced a method by which in low absorption towers, connected with each other counter-current, aqueous sulphurous acid is first prepared, which is then saturated with the desired quantity of the base in tanks filled with limestone, and methodically connected in series.

The importance which D. Kellner has from the start paid to the proper cooling of the sulphurous acid gas from the furnace, may be inferred from the dimensions, which he gave to the respective cooling arrangements. The manager of one of the oldest Bohemian factories, planned after his system made to the author the concerning statement that Kellner had recommended a system of pipes, 14 meters long and 3 meters wide, presenting a cooling surface of from 55 to 60 square meters. Besides, when these cooled gases are drawn by means of a pump through the one or several towers thereby rendering the saturating of the water entirely independent of the draft in the tower, the formation of the leach becomes much more uniform than is possible in the Mitscherlich process.

In connection with this it may be mentioned that some factories, and especially those working the Ritter-Kellner system, use commercial liquid sulphurous acid, either exclusively or as a reserve, for convenience or uniformity. This is stored in a strong vessel, provided with pressure gauge and gauge glass, and can be used any time, either directly or to improve the leach from the tower, when it is too weak. In most instances, however, the liquid sulphurous acid comes too high and besides much care has to be observed in transportation during summer, because direct sunlight may cause so much heating and also evaporation of the sulphurous acid that there is danger of explosion. The accident in the cellulose factory in Ober-heschen, some years ago, should be a warning. Sometimes it is com-

plained that much sulphuric acid is still contained in the liquid sulphurous acid.

Lately Dr. Kellner has recommended still another dissolving method, i. e., to employ gaseous chemicals instead of liquid leaches. In the *Papier Zeitung* the following statement has been made by him: Until recently the vegetable materials used for the manufacture of cellulose were treated with liquids suitable to dissolve and decompose its incrusting constituents. This has the disadvantage, that a very large quantity of the liquid chemicals, as well as their employment under pressure or high temperature is necessary. The present invention concerns a method by which the production of cellulose can be attained with much less expense in chemicals and without the application of pressure or high temperature (except in some cases, where the structure of the plants is especially dense); resulting in considerable saving and besides a much less weaker end product.

This process is characteristic in this, that the chemicals which are to decompose the incrusting substance of the vegetable materials, are brought in contact with them in gaseous condition. For this purpose all those chemicals, are suitable which exercise upon the incrusting substance a hydrolytic or oxydizing influence, especially nitrogen-oxide, nitrous-acid, nitrogen, peroxide and chlorous acid. In working this process, the more or less dry vegetable materials are if necessary previously steamed and exposed to the action of these chemicals in vessels, made resistant to the gases and vapors mentioned.

The vegetable material treated in this manner is then, according to the kind and quality, worked with cold water or steamed, or else put under mechanical treatment (in mills, etc.), after which they are treated with an alkaline solution in order to dissolve in the alkalis the incrusting substances previously decomposed by the gases and vapors. The so treated vegetable material is then violently agitated by machines such as are used in the paper industry, in order to get the cells laid free by the treatment, out of their parallel position. After this the produced cellulose is washed and if necessary, bleached.

It is of special advantage to expose the vegetable material treated with the gaseous and vaporous and gaseous oxydizing means, after washing with water, to the action

of ammoniac vapors, because the ammonia can easily be recovered in a pure state of heat. With some kinds of wood, carbonate of soda or caustic soda must be used to dissolve the incrusting substances; in such case the alkaline solution is advantageously added at the same time, when worked in the roll or stamping mill, because using the latter requires but a small quantity of the alkaline solution and it is quickly distributed through the vegetable material.

To avoid the repeatedly mentioned disadvantages of the towers and to be able to use with more convenience the burned lime, which combines more readily with sulphurous acid, a number of vessels filled with milk of lime, were put in use and thus the so called chamber apparatus was formed. The chambers of mason work, closed on top, are to three-quarter of their height filled with milk of lime, through which the gas, coming from the furnace, has to pass. To this purpose partition walls go from the top down near to the bottom so that in every chamber the sulphurous acid gas is forced to pass downwards through the milk of lime and to rise up again. Because by itself this would not go on quickly enough, a ventilator is used as a rule, which is placed behind the last chamber, causing a draft. In the same place an injector is often used, or a chimney to create the necessary draft. This chamber system has been brought to the greatest perfection by W. Flodquist in Gothenburg, who has placed 10 chambers in a series so arranged that the solution is circulating through the chambers until it possesses the required strength of 5° B.

A method quite similar to the chamber system has been patented by the Englishman, Dougall. The American patent No. 311,595 was described in the *Papier Zeitung*, with illustrations, represented in fig. 37: The process consists in burning sulphurous or pyrite in strong retorts, into which, after the sulphur has started burning, compressed air is introduced by means of a powerful blower. The sulphurous acid thereby produced is by a system of pipes let into a number of vessels, which are filled with water or alkaline solution. In these vessels the gases are brought in contact with the liquid and the absorption so effected. Instead of this arrangement an exhaustor may be used at the opposite end, which draws the air through the retorts,

In every case, the temperature of the retorts is kept as low as possible, so that few gases can escape. For this pur-

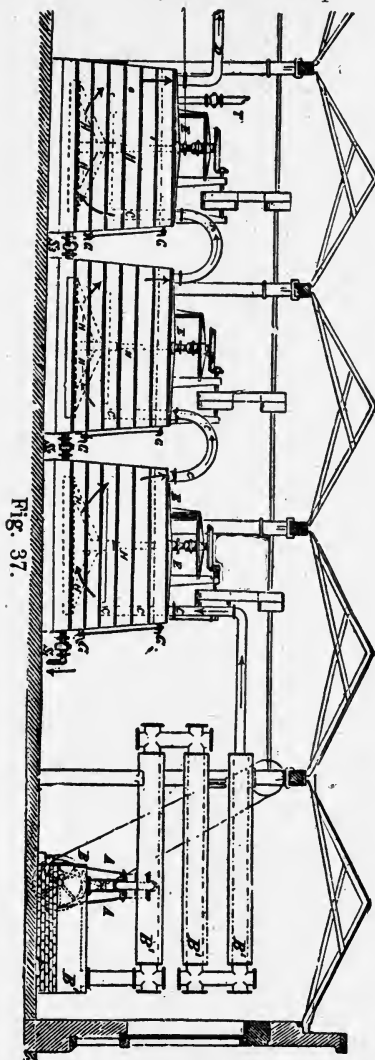

pose, the retorts in which the burning of the sulphur is af-

fects, are surrounded by a water jacket. The pipe system, carrying the gas to the saturation tanks, is also provided with a water cooling device. The sulphurous acid gas is entering into the tanks directly below the water level. These tanks are provided with stirring arrangement. By the aid of this explanation the different parts of the plant can be easily found in the sketch. A is the blower, which drives the air through the retort B. After the sulphur inside the retort has been lighted with a hot iron, it receives a liberal air supply from the blower, and the combustion goes on at once without being further assisted by outside heat. Overheating, which would be detrimental to the process, is prevented by the water jacket B1. The pipes next connecting to the retort B are also provided with a water jacket, B1. The pipe C then carries the gas to the tank E, in which the stirrers H, are arranged, so that the liquid comes in close contact with the gases.

A number of such tanks E communicate by the valves S1, S2, S3 etc. As long as the circulation of the gases is going on these valves are closed. The water or the dissolving agent is filled in the last tank through the pipe F. Before the gas is blown in, the tanks are filled through the valves S, so high that the pipes B are considerably below the level and the gas is driven right into the liquid. The gas in excess is carried off from the last tank through the pipe D. To control the height of the liquid in each tank and for the taking of samples, glass tubes GG, with cocks are provided. The work proceeds in the manner, that the gas is driven through the tanks until the solution in the first tank has reached the desired point of saturation. The blowing is then stopped, the liquid is run off from the first tank and by opening the valves S2, S3 and F, it is filled up to its former level. The blowing is then started again and continued until a solution of the required strength is again obtained in the first tank. The number of the tanks must be made large enough so that through the pipe D but a small excess of sulphurous acid can escape. Previous to Dongall's invention, W. Y. Turner had in 1872 obtained a patent on forcing air through closed sulphur furnaces.

Upon nearly the same principle is based a leach apparatus, which Dr. A. Frank in Charlottenburg, has designed and which does not have the drawbacks of the methods so far described. In a lecture, which Dr. Frank

delivered at the convention of the cellulose manufacturers at Berlin in 1887, the advantages of his plant were presented and about the disadvantages of the principal former methods for leach-making the following was said: "Concerning the tower it must be admitted that in principle, they represent the simplest plant, in practice, however, first, the depending of the draft, and with it, of the whole plant, on the outside weather conditions cause much trouble, and in many instances this has necessitated the providing of ventilating arrangements worked by machinery. It is not less a drawback, that but few limestones are perfectly suitable for the filling of the towers, as too hard a stone dissolves too difficultly in the weak acid, while soft or impure stones sink together and hinder the free passage of the gas. Another important shortcoming in connection with the working of towers is the continuous oxydation of a not insignificant quantity of the sulphurous acid into sulphuric acid, not only lost to the process, but also coating the limestones with almost insoluble sulphate of lime (gyps), which prevents the further action of the sulphurous acid. In consequence of all these circumstances these solutions come out unevenly and often weak, especially in summer, and as corrections cannot well be made while the work is going on, the trouble of clearing the tower is in such cases unavoidable. In the second method, based upon limestone (battery with compressor) the difficulties caused by the regulation of the draft in the tower, are surely dispensed with, but the other mentioned troubles especially the coating with gyms and the clogging with mud, are still retained and to this is added the expense of setting up and maintaining the compressor pump needed to force through the sulphuric acid gas. Another shortcoming, common to both apparatuses must be considered, that in consequence of their very arrangement for continuous work they always contain an excess of limestone, and therefore, as long as they are in good order, i. e., as long as the lime charge is not extremely coated with sulphate, they yield leaches very rich in monosulphite of lime, but poor in free, active sulphurous acid, which denotes itself by high specific gravity with proportionally low per centage in sulphurous acid. The effort to remedy this by charging the towers but partially with limestone, and partially with chemically inactive porous substances, which

shall effect a distribution of the leach and facilitate absorption of the sulphurous acid, has certainly been not altogether without success, but has made the plant very complicated and rather increased the other drawbacks mentioned (loss of sulphurous acid by oxydation, etc.).

When in place of the solid carbonate of lime (limestone) the burned or quicklime is slacked and used in the condition of milk of lime, a great many of the difficulties mentioned are done away with. The absorption of the sulphurous acid by caustic lime is affected much more energetically and completely than by carbonate of lime, therefore the chances for oxydation are lessened, and secondly, the apparatuses can be smaller and are more economically attended to. Besides, when using caustic lime the working is not continuous, as when limestone is employed, one has it in hand to fix and regulate as desired the amount of lime in the leaches. As already mentioned, two methods of circulating the gas through the milk of lime may be employed, i. e., drawing and forcing. Of these two methods what appeared to be the most simple has been chosen, by placing behind the last absorption tank an injector producing a vacuum, which by its sucking action suffices to keep the sulphur burning and to draw the gases formed after they have passed a cooler and washer, through the milk of lime. A closer examination of this method soon proved some considerable deficiencies, among them the almost enormous consumption of steam by the injectors used; according to low estimates, with an apparatus producing 25-30 cubic meters of leach per day, the consumption of steam is equal to that of a 30 horse power engine; a second, still more essential failing in drawing the gases is, that the saturation of the leach with sulphurous acid is thereby possible in but a limited measure. Because low pressure will exist in this apparatus, the liquid contained therein takes up less sulphuric acid than when saturated with the gas under full atmospheric pressure, just as in a glass of seltzer water the carbonic acid gas would escape in large bubbles when brought into a room under diminished pressure. Especially during the hot summer months the leaches made by this process therefore come out very weak. The full benefit of the advantages offered by working with slacked lime can, however, be gained, when instead of drawing the gases, they are forced through the liquid. Dr.

Frank claims as advantages of his apparatus the following:

First, the apparatus makes possible, independent of outside weather conditions, the steady and uniform preparation of the leaches, of which inside of certain limits the strength in lime as well as in sulphurous acid can be perfectly kept under control. The strength can be raised up to 10°B. Second, the plant can any time be stopped and started again. Third, the mechanical power, necessary in the plant is small, only five to six horse power, and for an output of 30 cubic meters in twenty-four hours, but one man is required per shift. Fourth, the absorption of the sulphurous acid is complete and bad odors caused by escaping gas are entirely avoided, so that the plant, requiring but little space, can be put up in any locality and a special building is not required. A room of 8x12 is sufficiently large. Fifth, in consequence of the complete absorption and the safe control of the combination of the sulphur in the furnace a better use of the sulphur material is made, so that by this, as well as by the rational preparation and composition of the leaches, considerable saving in raw materials (sulphur and lime) is gained. Formation of gyps and mud settling does not occur in the apparatus. 6. The apparatus, of simple and solid construction, is in all its parts easily overseen and easy to get at, and is without easily destructable or sensitive parts. 7. The apparatus, though in the first place constructed for the use of sulphur, can nevertheless be used in connection with pyrite furnaces. 8. The apparatus also makes it possible to retain and use over again the sulphurous acid blown off from the digester, without much additional cost and without violating existing patent rights. 9. The cool water required by a large sized apparatus amounts to 200-300 liters per minute. 10. Delay of work by sublimation or clogging of the pipes is altogether excluded and all injury to workmen as well as to the neighborhood by escaping sulphurous acid is absolutely avoided.

In regard to point 7 it may be mentioned that the author was informed that the Frank apparatus could not be advantageously used in connection with pyrite furnaces, because the gases coming from pyrite furnaces are poorer in sulphurous acid and richer in oxygen and because in a solution of bi-sulphite, oxidation is going on quicker, and considerable deposition of sulphate of lime takes place in

the lime milk tanks. On account of direct assistance from Herr D. Frank, the author is able to give the following description of his apparatus:

The plan of Frank's leading apparatus can be seen in figs. 38 and 39. By means of the air pump B, which may be worked by water or steam power and which is provided with the air chamber C, the air necessary for the combustion of the sulphur, is forced into the well closed sulphur furnace A, in such exactly measured quantities that gases of high grading, rich in sulphurous acid, are obtained. Because the furnace itself as well as the cooler D and the dust chamber E, arranged in the back, are kept cool and as the supply and distribution of the air in the furnace

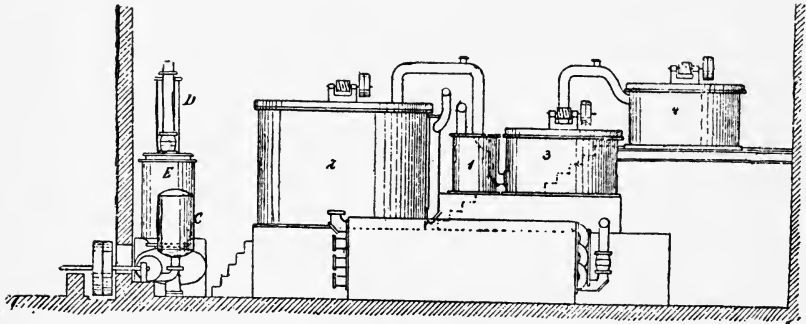

Fig. 38.

A is done in a peculiar manner, which also make entirely secure the burning of any evaporated sulphur, sublimation of the sulphur and clogging of the cooling pipes can never occur. From the dust chamber E the gases then go to the cooling coil F, surrounded by water, which in order to make the consumption of water as small as possible are constructed according to the counter current principle. From there the gases go to the small washer 1, in which the small residue of sulphurous acid gas is retained. The cooled and purified gases then enter the absorption battery, composed of three vessels. These three vessels are placed one above the other in such manner that the gases first pass through the solution in tank 2, the one most saturated with sulphurous acid and are by the adding of water diluted to the required strength. Then they enter tank 3, filled with a stronger milk of lime and lastly the uppermost tank 4, charged with fresh milk of

lime. Basins 2 and 3 are tightly covered so that the gases can be forced through. Basin 4 may be covered, but as the last traces of sulphurous acid gas entering in there are rapidly and completely absorbed, it is generally left open, because trouble from escaping gas does not occur.

When the leach has become thoroughly saturated with the sulphurous acid, which can be determined in three minutes by a sample taken any time during work, the sulphur burning in furnace A is put out by simply stopping the air from the compressor and thus ceasing at once

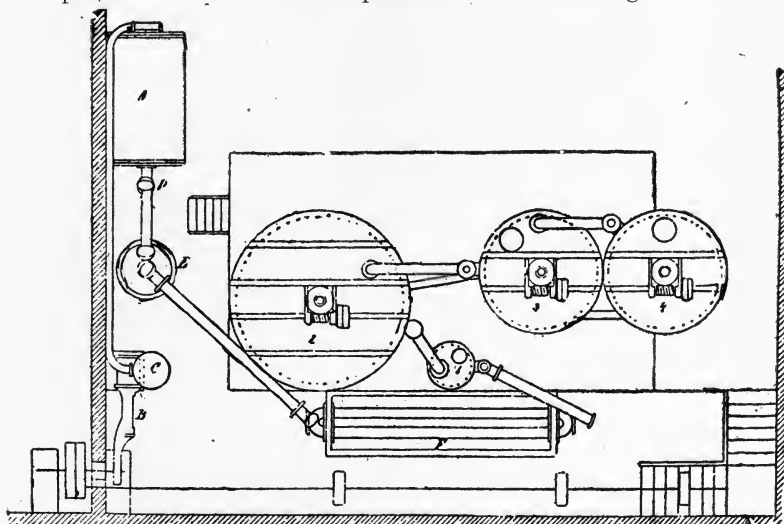

Fig. 39.

all evolution of sulphurous acid, of which also nothing can go back into the room, because the furnace is closed. The finished leach in tank 2 is then run out and from tank 3 the concentrated half finished milk of lime is let over through a pipe in the bottom, closed by a valve, and water is added. Into the emptied tank 3 the leach from tank 4 is then run over and the latter is filled again with fresh strong milk of lime, which has been previously prepared in a box arranged above tank 4 from a measured quantity of burned lime. The whole operation of emptying and filling over does not require over 30 minutes. When this is done, the furnace, meanwhile thoroughly cooled off, is



opened and again charged with a weighed quantity of sulphur, and after this has been ignited, the operation is started again by reversing the air pump. According to the size of the different parts of the apparatus, which can be exactly calculated in advance, 10 to 20 cubic meters of leach can be finished in one operation and as the time required by one operation, including all side work, as feeding of the furnace and filling over of the tanks, does not exceed seven hours, the capacity of a small sized apparatus is about 30 to 35 cubic meters per double shift and of a large one about 54 to 60 c. m., whereby the labor of the attention, besides controlling the burning of the sulphur in the furnace, is limited to the opening and closing of some valves and slaking of lime, which occurs about three times every double shift.

To arrange the apparatus for continuous working, i. e., with continuous discharge of leach and charging with fresh milk of lime, is certainly also easy, but W. Frank gives decided preference to the intermittent method here described, in which the charge of the large tank is always finished and discharged at once, because in this way the exact control of the process, especially of the proper composition of the leach, is much safer. The strength of the gases in the sulphur furnace can also be by this method exactly adapted to the existing requirements by regulating the air pump.

With Frank's apparatus sulphite leach can be prepared from lime, dolomite, pure magnesia, and also from soda, in any strength up to 10° B and perfect, considering the circumstance, that the leaches made with it from lime cannot deposit monosulphate (gyps.) in the digester.

W. Frank's remarks about the disadvantages of the towers, which are quite correct, cannot, however, be considered right in regard to the Kellner process. Mitscherlich has at the same time used his towers for aspirators. But the aspirating effect is continuously influenced and with bad effect by changes in the specific gravity of the outside air (change of temperature, etc.) as well as by the continuous changing of the exposed surfaces of the limestones and of the water, drizzling down. The gases also must enter the tower with high temperature, because otherwise there would exist no difference in weight between the already heavy sulphurous acid and the outer air, or in other

words, no draft would exist. These disturbing factors are avoided by Kellner in such manner that; 1, the sulphurous acid is much cooled down; 2, the gases are pressed forward under low pressure through the chambers or towers or tanks filled with limestone. Entire independence of the variations noted is thus gained and a series of absorption apparatuses, as long as desirable, can be connected, so that a perfect absorption of the sulphurous acid can be secured. By this means it is just as easy to regulate the proportion of the sulphurous acid to the lime or in other words, of the free and combined sulphurous acid, by filling part of the absorption apparatus not with limestones, but with an indifferent material, like pieces of brick, pebblestones, etc., and consequently the bisulphite solution obtained from the limestones, is enriched with as much sulphurous acid as deemed desirable.

The exhausting of the sulphur, according to the simple method reported by Dr. Frank in the *Papier Zeitung*, is determined by measuring the produced leach and titrating for sulphurous acid with iodine. As one per cent sulphurous acid corresponds to the 10 kilograms contained in the cubic meter, and one part of chemically pure sulphur in complete combustion yields two parts of sulphurous acid, theoretically 5 kilograms of pure sulphur should yield 10 kilograms of sulphurous acid; however, the second quality sulphur used in most factories generally contains but 98 per cent and as on account of moisture in the air used in combustion, the formation of small quantities of sulphurous acid is never entirely excluded, and when discharging and filling over small losses of leach cannot be avoided, Dr. Frank guarantees 95 per cent consummation of the sulphur charged to the furnace, so that of 100 kilo sulphur, weighed and charged to the furnace, 190 kilo effective gaseous sulphurous acid in the leaches are obtained. That in careful working a higher result may be obtained, is shown by the results from the factory of J. Spiro & Son in Böhmisch—Krumau, published by Kymmene Bruck, according to which the exhaustion of sulphur reaches 96.8-97 per cent; consequently from 100 kilo of sulphur 193.6-194 kilo of sulphurous acid were produced.

Regarding the composition of leaches produced with Frank's apparatus already mentioned, Dr. Frank has, on the

basis of scientific investigation, which have been more fully confirmed by results obtained by working on a large scale, secured the taking of the percentage of lime in the leach as low as possible, as the main effect depends on the free active sulphurous acid only, while a high percentage of lime besides other uncertainties, requires unnecessary consumption of sulphurous acid, i. e., of sulphur material. In proof of this, Dr. Frank quotes the following example: A factory leach A of 7°B contained, total sulphurous acid, 4.35; of this, free acid, 2.35; of combined acid, 2.00; and lime corresponding to the latter, 1.75.

A leach of nearly 5°B prepared in Dr. Frank's apparatus, with which the boiling was effected in exactly the same time, but without formation of sulphate (gyps.) contained: Total sulphurous acid, 3.254; of this free acid, 2.382; of this combined acid, 0.874; and lime corresponding to the latter, 0.764.

It can be noticed that the leach B, regardless of its low specific gravity and low percentage of total sulphurous acid, is richer in free active sulphurous acid than the heavy leach A, also, while the preparing of the latter in Frank's apparatus requires at 95 per cent expansion about 23 kilos of sulphur per cubic meter leach, for the same quantity of leach B but 17 kilo of sulphur are necessary, so that besides the considerably higher effectiveness of all apparatuses, with the rationally composed weaker leach a direct saving of 6 kilos of sulphur per cubic meter leach is gained.

In the further working of the material produced with both leaches at the factory mentioned it has been settled that the cellulose digested with the 7° leach yielded 1.85 per cent ashes, while the one boiled with the weaker leach gave but 0.36 per cent.

For the expert in the matter it need hardly be mentioned that there can be no general directions in regard to the composition of the leaches, suitable for every kind of wood, as well as for all methods of boiling, but that such must be conformed to material and process. Where the steam does not enter directly into the boiler the leaches do not get diluted and a weaker solution can be worked, but when the steam enters directly, especially when it is not sufficiently dry, weak and dilute leaches are caused. So for instance at the factory in Kruman with digesters

according to the Mitscherlich system a leach of, total sulphurous acid, 3.035; of which free acid, 2.023; of which combined acid, 1.012, and lime corresponding to the latter, 0.827, for which but 16 kilos of sulphur per cubic meter were necessary, has proved entirely sufficient.

Against the 7° leach, mentioned above, a saving of 60 marks per day would result at a daily consumption of about 80 cubic meter leach.

Quite a large number of Frank's apparatuses have been in use some years, in connection with different systems of digesting.

According to information from the machine works of Golzern the price for one leaching apparatus of 50 cubic meter daily capacity, completely mounted, put in working order and delivered with reference to the exhausting of the sulphur, as guaranteed, is about 24,000 marks, inclusive of license and mounting. The daily production of 50 cubic meters of leach of 3.3 per cent sulphurous acid and 1 per cent lime costs:

For 870 kilos sulphur at 11.00 marks per 100 kilos,	95.70
For 550 kilos burned lime (including loss in slaking) at 1.50 marks per 100 kilos.....	8.25
Wages for 2 shifts at 2.50 marks	5.00
Power of 5 to 6 horse (if not furnished by water motor) at 2.5 kilos cost per hour and horse-power calculated per 100 kilos at 1.50 marks.....	6.00
Lifting of 200 to 300 liter cool water per minute, light, lubricants, etc.	5.00
5 per cent. interest, 10 per cent. amortization of 24,000.00 marks per day	12.00

M132.00

or 264 marks per cubic meter.

Besides the low cost of production, the special advantage is gained against the use of pyrite, that the working of the apparatus can be started and stopped at any moment, and the accumulation of the residue pyrite, so annoying in many factories, is done away with.

The method of Dr. Frank has in recent years on account of its advantages come more and more into use because the making of leaches with it is in fact very clean, handy and uniform, and entirely independent of the season. As figs. 38 and 39 will show the arrangement of the Frank plant,

but do not give a distinct picture of the form of the sulphur furnace proper, two cuts, fig. 40 and 41, have been added. It can be seen that the sulphur furnace O has the shape of a flat tube, with both ends made of cast iron, the level bottom almost entirely taken up by the low sulphur pan S. The sulphur to be burned, previously weighted, is put in the pan through the door T, there spread, and lighted by means of a red hot iron bar. The

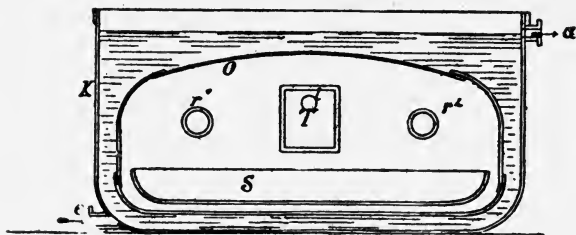

FIG. 40.

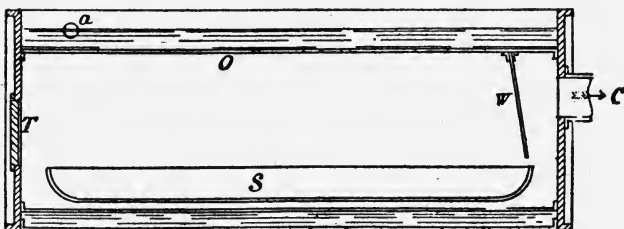

FIG. 41.

right state of combustion can at any time be closely controlled through the hole *l* in the door, covered with a strong plate of glass. When the flame is burning deep blue, all is in good order, but if by evaporating sulphur colored yellowish-brown, more air must be admitted. The supply of air and the regulating is done through the two pipes *r1* and *r2*, which may be totally or partially closed by valves. In order that the air may come in close contact with burning sulphur at the rear end of the furnace a partition *W* reaches from the ceiling down near to the pan, so that the air together with the evolved gas must strike close over the pan before it leaves the furnace at *C* and is carried away, as already described.

In comparison with the pyrite furnaces, which produces

gases of only about 8 per cent, the sulphur furnaces works considerably better, because, as already mentioned, the air supply can be exactly measured and gases of up to 15 per cent can be produced.

The leach plant of Frank's differs from a pyrite furnace plant not only in the absence of the pungent smelling sulphurous acid, but also in avoiding all radiation of heat. This is attained by placing the entire retort inside of a large box, K, of sheet iron, near the bottom of which cold water is continuously running in at e, surrounding the retort and cooling it and running off again as warm water at the top at a. In this manner it is not only much more pleasant to stay in a factory with one or more Frank apparatuses, but at the same time all annoyance to the neighborhood, as well as therefrom resulting damage suits are done away with.

In most of the sulphur furnaces of this system in use about 1,500 kilos of sulphur can be burned in 24 hours. This quantity is sufficient for most factories, but it is advisable to have a complete apparatus in reserve so that in case of any irregularities it does not become necessary to stop the operating of the whole plant. At times, when the apparatus is not in use, it can advantageously be otherwise employed. Thus the tanks may be fitted with milk of lime, the excess of sulphurous acid in the digester blown into them, and so not a small quantity of leach of various strengths is easily obtained.

Some variation from the already described methods and a similiarity with the Douglas process is marked in the system of leach making by the Englishman, Edward Partington, whose process is explained as follows: This invention relates to the manufacture of sulphurous acid and its combinations by a continuous process, the essential of which is that the water or the alkaline solution enters by gravity from one tank into another, while gaseous sulphurous acid at the same time is circulating in an opposite direction successively through the water or alkaline solution in each receiver, while the water or alkaline solution is kept in constant motion, by a rotating stirring arrangement. In the accompanying fig. 42, three receivers A, A1, and A2 are shown, while at the cover as well as at the bottom are in connection with each other for a purpose later on explained. Each of the receivers, which are made

of wood or any other material suitable for the manufacture of sulphurous acid, or sulphites and bisulphites of the alkalines and alkaline earths, consist of a cover a, the bottom a1 and the sides a2, the latter being cylindrical. The side walls of every cylinder carry the traverses b (fig. 42), to which are fastened the stands b1 bearing the shaft b2, with fixed and loose pulley, to drive by belt. At one end of the shaft b2 is the bevelled gear b4, driving the wheel b5 on the shaft b6, going through the stuffing box b7, fixed to the cover a, into the tank. The shaft b6 is held at its upper end by a frame and reaches almost to the bottom of tank A1. It is provided with the bars d, connected by the cross bars d1, forming together with the shaft a stirring arrangement by which the liquid in space B of the tank can be stirred about.

The liquid for making the sulphurous acid can be either water, or any solution containing a substance which can with sulphurous acid form sulphites or bisulphites. For the present case calcium hydrate is supposed which enters the tank A near its cover through the pipe e. The tank A1 connected by the pipes e1, e2; the pipe e1 leads from the bottom in A below the cover of A1, while pipe e2 goes from the cover of A to the bottom of the tank A1—A1 is connected with A2 in similar manner by the pipes e3 and e4, of which e3 leads from the bottom of tank A1 below the cover of A2 and e4 reversed. The tank A2 is in the same manner provided with the pipes e6 and e7, which are shown broken off in the sketch, to connect another tank in the same manner. The pipes e1 and e3 are provided with valves, by which the connection between the tanks is broken. When beginning work, the valves are closed, whereupon the liquid is run into tank A through pipe e. In practice it is preferable to have the liquid constantly run in during the operation, so that it runs from A through the pipe e2 into A1, from A1 through e4 into A2 and from A2 through e7 out. By the gravity of the liquid a constant flow through the tank is thus maintained and a current of sulphurous acid is drawn in the opposite direction through the liquid by means of an exhauster, not visible in the sketch, connected to tank A by pipe f3. The gas is first admitted through the pipe f to the inner or space B of the tank A2, where it enters into two places at the bottom and goes from space B through pipe f1 into space

B of tank A', from there through pipe f2 into space B of tank A and is drawn out through pipe f3. During the process gases and liquid are well mixed by the stirring arrangement, which can be driven by the arrangement de-

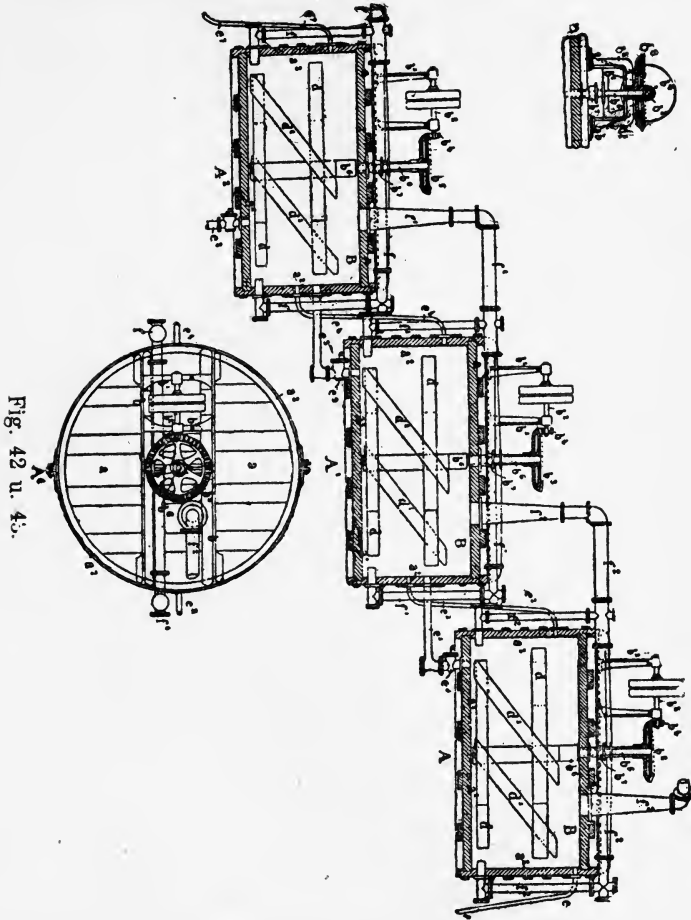

scribed or in any other suitable manner. The liquid transformed into sulphurous acid or sulphite or bi-sulphite flows from tank A2 through the outlet pipe e7 and is then ready for use. The finished leach runs into four

air tight storage tanks, 10x10x8, and is from there pumped to the digesters.

In Partington's factory the sulphurous acid is produced in a sulphur furnace of 2x8, by burning of pure regenerated sulphur of 99 per cent. and of pyrite (with 48 per cent. sulphur) and it first circulates through a system of pipes, cooled with water, before it is permitted to enter near the bottom of the lowest tank.

After the preparing of leaches, as performed according to the methods, mostly employed in Germany and England, has been fully described, some other methods, as given by Professor Hoyer in his book, shall for the sake of completeness be shortly treated in this chapter.

Eckman uses as leach a solution of sulphite of magnesia, which contains two equivalents of sulphurous acid for one equivalent of magnesia and in such concentration that almost 1.4 per cent magnesia and 4.4 per cent sulphurous acid are present in it. To prepare the sulphite, Grecian or German magnesite is calcined in lime kilns, then in towers of lead (with inside wood lining to protect the lead) exposed to sulphurous acid, produced from sulphur and to water drizzling down and finally discharged as sulphite solution.

In the process of Franke in (Sweden) a solution of acid sulphite of lime is employed, made by leading hot sulphurous acid, produced by roasting pyrite in a tower 13 meters high, divided into several vertical chambers, which are filled with limestones and which can be charged and attended to independently of each other, and to which water is admitted from above in quantities just sufficient, so as to secure a warm solution, at once ready for use. The solution is run into receivers of cement, lined with lead and from there it is pumped to the digester.

In the method of Graham in London, at first only the solution of the monosulphites of any base (potash, soda, magnesia) is charged into the digester and after it has been freed from air and carbonic acid, the effective combination is produced by pumping in sulphurous acid gas or solution. In this method, which is effected in a vertical digester with steam jacket, the escape of acid is prevented in the first place, but the liquid is steadily maintained in equal strength by filling up from the bottom, when necessary.

The method of Picket in Lausanne, (D. R. P. 25331) is based on the theory that in consequence of the high temperature now generally used, the gums and resins in the wood are changed into tar and thus render so difficult the bleaching of the product that it is practical to employ a solution of sulphurous acid, which would dissolve the incrusting substances at a lower temperature. For this purpose Picket recommends an aqueous solution of sulphurous acid. But as 100-500 grams of sulphurous acid have to be dissolved in 1 liter of water to obtain a pressure of from 5-7 atmospheres at a temperature of 80-90° C in the digester, liquid sulphurous acid anhydride is charged into the digester under pressure under the above mentioned conditions. The acid mixes with the water and yields the desired solution, which in the digester by steam evils is raised to the the temperature of not over 85°C, because at 90°C carbonization would begin. To make the liquid thoroughly penetrating, it is recommended to produce a vacuum before it is charged to the digester, to open the pores of the wood.

The aqueous solution prepared according to this method (without alkali) contains about 1 1-2 to 2 per cent of sulphurous acid. When the necessary quantity of this acid together with the wood is charged into the digester, in another boiler a liquid of the same kind is heated to about 100° and the sulphurous acid thus set free is driven over to the digester until the leach in there contains .2 per cent acid. After the operation is finished, the acid is driven off in the same manner and used for the preparation of new leaches. The highest temperature employed is 105°C. The essential difference of this method in comparison with other sulphite processes is therefore, that no lime is contained in the solution, while a small per centage is really necessary in order to neutralize the sulphuric acid, which forms. The resulting product is less white than with other methods.

According to Flodgnist in Gothenburg, in preparing the digesting liquid, the sulphurous acid is partially led over limestone, partially over bones, the fat of which has been extracted, which are piled up in towers or chambers, to form a mixture of sulphite and phosphate of lime and besides to produce glue material for the manufacture of glue, wherefore always several chambers (as already mentioned,

as many as 10) are in use, so that one after the other can be disconnected for discharging and refilling, as necessary.

The method of Archbold in Oswego, is based on the principle to produce sulphite of lime directly upon the fibre, in order to make it thus act so much more powerfully. To this purpose the raw material, i. e., the dressed wood, is first saturated in the digester with milk of lime, which consists of from 1 to 6 parts of lime in 100 parts of water, and for hard wood, also 1 part of nitrate of lime. Then sulphurous acid (either in gaseous or in liquid form) is charged to the digester and after about five minutes it is exposed to a pressure of from 4 to 5 atmospheres and sometimes, according to the kind of wood, for one to two hours and a half.

At the end of this chapter about leaches and leach-making in regard to sulphite leaches it must be mentioned again, that measuring the concentration with the areometer, in use in most factories, does not give a correct result, and to the advantage of the digesting operation it is highly desirable that the leaches be tested every time before using, by analysis, for their strength in active sulphurous acid. This is possible without a complete laboratory outfit, by the following method of Dr. E. Hoehn, based on the reaction of iodine on sulphurous acid under decomposition of water, forming hydroiodic acid on the one side, and sulphuric acid on the other. When therefore a solution of pure sulphurous acid is extricated and to this for instance 10 cubic-centimeters one-tenth normal iodine had to be used, at the end of the reaction the liquid will contain a certain quantity of hydroiodic acid, corresponding to 10 cubic-centimeters one-tenth normal-iodine, and an equal amount of sulphuric acid, so that in neutralizing the acid formed by an alkali, 20 cubic-centimeters one-tenth normal-soda will be necessary. But in place of uncombined free sulphurous acid in the solution to be tested, there is an acid sulphite, for instance, of lime, the same amount of sulphuric acid is formed in the titration, but which will be partially neutralized by the base already existing, so that in titrating back the two acids formed, the double amount of cubic-centimeters of iodine is not necessary, but much less suffices.

SODA PROCESS.

It lies in the nature of the soda process, because the so-

da employed therein, like the alkalis in general, does not attack iron, that the boilers used in manufacturing soda-cellulose can be more simple, than the sulphite-digesters, which latter must be fitted with all possible appliances for protection. According to the method of working, they may have small or large dimensions, may be fixed or rotating, placed horizontal or vertical. In most instances fixed vertical boilers are used, because the process of boiling mostly takes place with circulation of the leach and a more effective stirring up is not absolutely necessary on account of the very large dimensions and weights of some of these digesters, it would be both difficult and expensive to make them of the rotary pattern.

The manufacture of soda-cellulose is really not a new invention, but only a modification of the method used in the manufacture of straw-stuff, as the wood is boiled with soda lye under pressure in a similar manner. It is twenty-five years since the present Commerciën-rath Herr Max Dresel in Dalbke, Germany, took upon himself this task of perfecting this process, and the author may be permitted to give here, according to the personal notes by Herr Dresel, a brief description of the details and results of the experiments, made 1871. First of all, in 1870, he acquired from the engineer James A. Lee, the rights and models for a chopping machine, which was previously built after a dye-wood chopper by Houghton in Manchester for the Cone paper mills in England. This Mr. Lee had at the time a small machine factory adjoining the Cone mills, near Sidney, England, and was engaged by contract to repair and superintend the mechanical plant. In this capacity he undertook a small change in the Houghton wood-cutter and then had the whole machine patented. The Cone mills, in 1870, were working with very primitive apparatus, part of which had been designed by the engineer Houghton, part of which was built after that used by Jesup & Moore, in Philadelphia, for the boiling of straw and poplar wood, producing very imperfect brown half-cellulose, which they were not able to bleach and which could be only employed for brown packing paper. On a voyage, undertaken in 1870, to England, Herr Dresel, while not allowed to inspect the Cone mills, found out that the boilers used in this factory for boiling straw and wood were designed by Mr. Houghton, who held a patent on

them. These boilers were horizontal cylinders, lined with a large system of pipes and the boilers themselves lay in the open fire. This pipe system was fed with water, thus heating the contents of the boiler.

In France, by the courtesy of the paper manufacturer, Dambricourt, in St. Omer, he examined a large straw boiler, which lay in direct fire, and had a large stirring arrangement inside, in which poplar wood was being boiled experimentally. According to the observations there made Herr Dresel concluded that, when with a boiler with direct firing, without a stirring inside, as in the Cone mills, poplar wood could be boiled, and when this was also possible, as in St. Omer, with direct heating in a horizontal cylindrical boiler with stirrer, it would also be possible to boil wood in a horizontal cylindrical boiler with direct fire and without inside stirring arrangement.

After wearisome trials he succeeded in finding a process of boiling with caustic soda in a small experimental boiler, which promised to answer also on a large scale for the dissolution of fir, and especially of pine wood. He then ordered a boiler forty-five feet long and four feet in diameter, designed for ten atmospheres practical pressure. After a complete plant had been finished, the large wood digester was put to work on October 1, 1871, and thus the first wood fibre factory on the continent was opened. To procure a practical scaling arrangement, which could stand the necessary high pressure, caused especial difficulties, but it should be considered, that in the beginning any leading points and examples for the preparing of leaches on a large scale, as well as for the duration of the process of digesting and all other occurrences were unobtainable, and consequently the first period of manufacturing caused considerable expenses. So much greater was the satisfaction then, when the results of the operations were yielding a product, capable of being bleached, which in many instances could serve as substitute for rag fibre in the manufacture of paper. The ideas worked out and tried practically in the first Dalbke factory, were taken up by the above-mentioned Mr. Lee, and by the engineer, Rosenham, employed by the Brackwede boiler works, and later introduced in Sweden under the name of the Lee system.

Regarding the process of digesting itself, a soda-leach of ten degrees B, a temperature of 360 degrees F., and a

pressure of from nine to ten atmospheres proved most satisfactory. The boiler contained or rather yielded 850 kilogramme of dry stuff.

After the first large digester had been in working for a longer period, a number of disadvantages were experienced with it, which were principally that with the intermittent use, the sudden change between strong heating and cooling off caused leaks in the seams of the boiler, which could not be wholly avoided and, not considering the large expense for repairing, caused heavy losses in leach. There was also a very unsatisfactory use of the

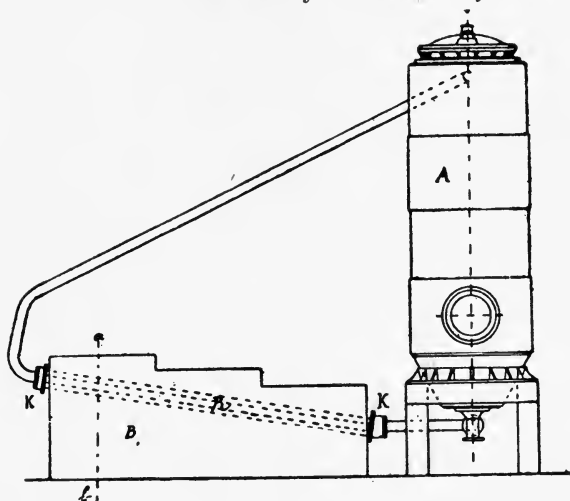

Fig 44.

fuel with this boiler, and the cost of heating was thus out of proportion. Finally the cooling off could be effected but slowly and only with loss of leach. For this reason, Herr Dresel has after much experimenting devised the construction, which has been patented to him under No. 5,891, in May, 1878, which is based on the principle of heating the digester without exposing it to the fire. This is done by direct heating, but without vapors and without dilution of the leach, by the automatic circulation of the leach, which may be brought to high pressure at will. Later on he improved this construction, and in 1878 he

took out a supplementary patent, which principally concerned improvements in the pipe-heating system. The following figures show the perfected construction: The upright cylindrical digester A, which is funnel-shaped below, has at the lower side a manhole for discharging and on top a wide fillhole with cover. In the middle of the lower bottom there is a nipple which is directly connected with the heating apparatus B, and also, if desired, with other boilers. This connection may be opened or closed, as required, by cocks or valves.

The heater B, directly connected with the boiler, con-

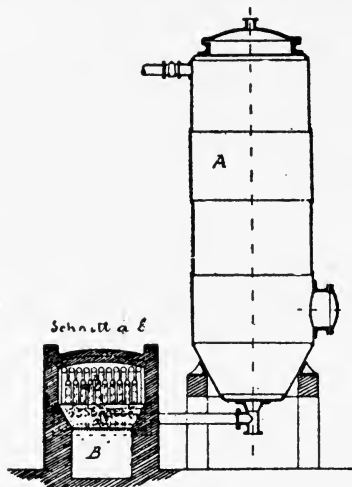

Fig. 45.

sists of a system of pipes R lying parallel either side by side or one above the other, at certain distances and with a certain inclination, which end in the narrow chambers K.

The liquid with which the digester is filled enters the lower chamber at one side, while the heated liquid ascends from the upper chamber at the other side, so that the liquid in entering the heating apparatus fills all pipes at the same time.

The liquid, which is quickly heated on account of the large heating surface, rises from the heating apparatus into the pipe, discharging into the boiler at its upper end and, circulating through the digester, returns into the lower

heating pipe chamber. In this manner an automatic circulation of the liquid takes place, and the contents of the digester can thus be heated by direct fire, without exposing the apparatus itself to the fire. By this arrangement a more rapid heating, energetic and even circulation in the digester is secured with almost no formation of steam. There is also a more perfect impregnation and more rapid heating of the contents of the digester, as compared with a heating apparatus formed by a horizontal coil, as designed in the main patent.

These cellulose digesters have proved very successful, and three of them have been at work since 1877, without one of them having to be repaired. Moreover, these boilers yield a very good product, are charged and discharged with ease, and have the great advantage of absolute safety and comparative cheapness.

With these patent digesters there is also the advantage that with them the operation can be finished in from two and one-half to three hours, and that the stuff can be washed in them without damage to the digester and without loss of material; further, on account of the energetic circulation, a uniform and complete solution of the incrustations is effected, which is proved by the fact that the cellulose made in them can be bleached white with from 8 to 9 per cent chloride of lime, while the other soda-cellulose require 12 and sometimes even 20 per cent of chloride of lime. The boilers are used for soda, as well as for sulphite-leaches, which in evaporating furnaces constructed by Herr Dresel are evaporated and then calcined in the so-called calcining furnace.

In an American factory the digesters have 1.5 metres diameter and 5 metres height. Inside there is a perforated false bottom and cover, which arrangement is provided in most boilers of this kind so that the wood cannot stop up the tubes, but is retained in the middle large space. The soda-leach has a strength of 12 degrees Beaumé and by direct fire it is gradually raised to the boiling point and the process is finished at a pressure of from six to eight atmospheres (160 to 172 degrees C.) in about six hours. Dahl, in whose process for 100 kilos of medium dry wood about 26 kilos of the salts are necessary, as mentioned in the chapter of leach-making, corresponding to a leach of from

six to fourteen degrees Beaumi, also boils in iron digesters with a pressure of from 5 to 10 atmospheres, and indeed from 30 to 40 hours. In order to obtain a good circulation in the digesters and still avoid direct firing, Koerting, in Hanover, who makes injectors a specialty, has used an in-

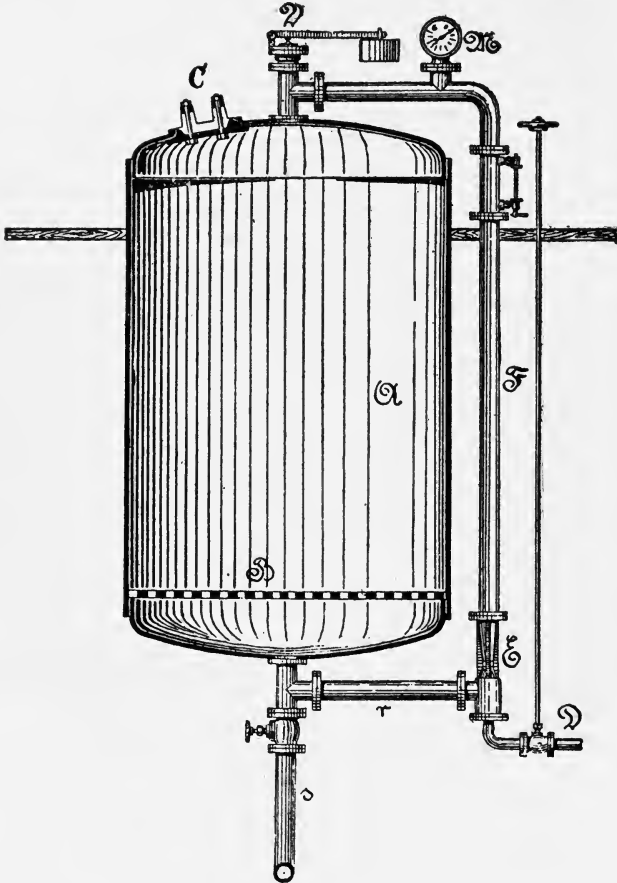

FIG. 46.

jector with a digester illustrated in Hoyer's work, page 190. Figure 46 shows this boiler: B is perforated bottom in the boiler A, which is built cylindrical with rounded

ends. The manhole C, serves to fill in the wood and the discharging is done by an opening above the bottom, not visible in the sketch. Alongside the boiler is a stand-pipe F, which is connected with the steam pipe D, and also by branch pipes with the lower and upper part of the digester which at E are connected by the well-known Koerting injector. The steam coming to the boiler through D draws by means of the injector E the leach accumulated under the bottom B through pipe r, forces it through the stand-pipe F into the upper part of the digester and thus not only effects proper heating, but also a lively circulation of the leach, which, after the finish and after shutting off the steam supply is let off through the pipe s.

For starting and maintaining the circulation of the leach it is only necessary that the pressure of the steam supply be by one atmosphere higher than the pressure in the digester. To regulate these conditions of pressure, which can be observed by a manometer M, a safety valve is arranged at C, which is weighted in proportion to the pressure required in the digester.

The system of Ungerer in Vienna, already mentioned as the most rational soda process for the best utilization of the leach, is described in regard to the digesting process by Hoyer as follows: The method is based on the principle of displacement and the work is done in such manner that the leach in certain order passes a number of digesters (Battery), which are heated by steam and charged with wood cut into thin slices. A battery consists of 7 to 10 upright, fixed digesters, which by pipes and valves are connected in such manner that steam or leach can be let from one boiler into another, as directed. With this system of digesters the work is so carried on that fresh wood, with the substances easiest dissolved, is first treated with steam which comes from the digester which is ready to be discharged, and then with leach weakest in soda, because richest in extractive matter, which comes from the digester, which was most recently charged with fresh wood, and has, therefore, passed all the other digesters and has started circulation with the boiler from which the wood is next to be discharged. If, for instance, the battery consists of seven boilers, A. B. C. D. E. F, G, in working, the leach is changed about as follows: When, for instance, C has been newly filled and B is to be discharged, steam is

first let from B into C to steam the fresh wood, the weakest leach is then run from D to C and so in succession; always stronger, from E to D, from F to E, from G to F, from A to G and from B to A. After about one hour the leach is let off from C, to be regenerated, while immediately after this discharge an advancing of the leach D to C etc., takes place, and A is charged with fresh, pure leach. In this manner every hour one digester is ready for discharge and its charge is washed with hot water under steam pressure, before being emptied. In the same degree in which the leach in its circulation becomes weakened, also the temperature and the steam pressure can decrease, which in this process, in which the leach by the continuous change comes to effect under the most favorable circumstances is in the digester, charged with fresh leach, not more than about 6 to 8 atmospheres for pine and 3 to 4 atmospheres for leaved wood. The fresh leach contains for pine wood from 5 to 6 per cent, for leaved wood from 3 to 4 per cent soda. The leach saturated with the extractive matter and incrusts from the last digestion is then by evaporation and calcination always recovered again for the process, so that according to the statements by the inventor, for 100 kilo dry cellulose but 5-6 kilo of soda get lost. According to age, growth and kind of the wood used, 1 volumeter wood yields from 100 to 120 kilo cellulose for pine wood and somewhat more for leaved wood (150 to 180 kilo). Further for 1 volumeter wood about 60 kilo soda of 90 per cent are estimated for conversion into caustic soda, of which 0.9 are recovered by regeneration.

B. SULPHITE PROCESS.

The boilers, which are used in the sulphite process and especially in the Mitscherlich process, first to be treated, differ from the previously described considerably, because on the inside, like all parts connected with it, they must be protected against the corrosive action of the sulphurous acid. Besides as the digesting process, according to Mitscherlich, requires much more time, it is a matter of consequence to arrive at boiling at once as much wood as possible, i. e., to make the digesters very large. Certainly not all factories working according to Mitscherlich, have horizontal boilers; some also have upright, of

somewhat smaller dimensions, most, however, have the horizontal digesters of 4 meter inside diameter and 12 meter length, which hold the enormous quantity of a 100 cubic-meters of cut wood and still have to take 60 cubic-meters of leach. With such dimensions it becomes necessary to use very heavy metal, at least 18 millimeter (at the half rounded heads still stronger) and also to consider the expansion of such iron masses in heating. In fig. 47 and 48 it can be seen that the foundation of the digesters is

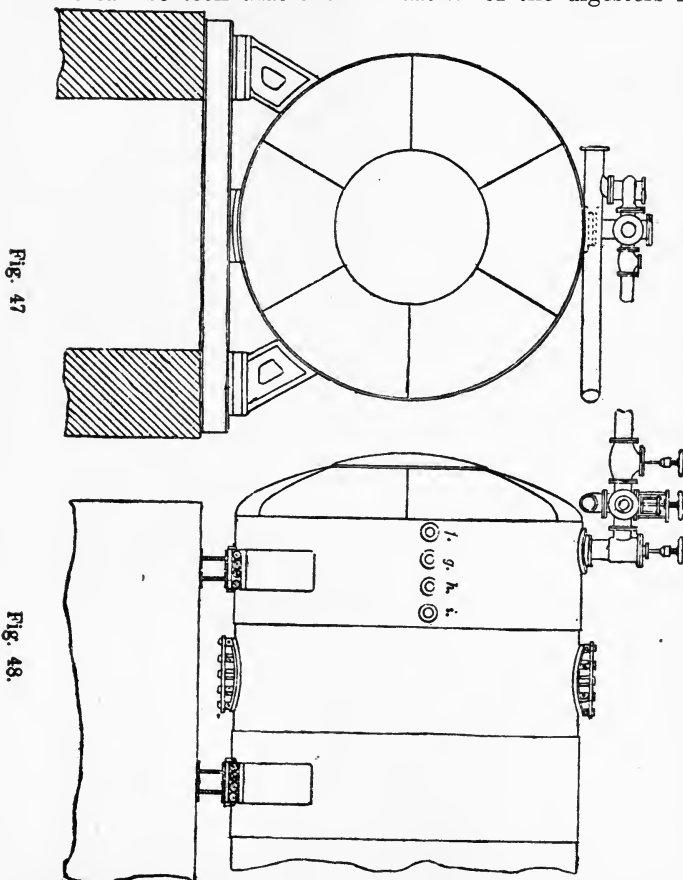

formed by two strong walls, over which 5 strong beams are

laid; the digester has riveted to itself five cast iron feet, which rest on these beams, but not immediately, as short iron rollers are between the feet and the beams, which eventually permit some expansion of the long digester. Two manholes on top, which by easily loosened screws can be tightly closed (the packing is done with rings of lead and by means of a paste of cellulose) permit filling from two sides at the same time and two oppositely arranged manholes below are for discharging, whereby after finishing the operation all four opened manholes let the air pass through and make thus some cooling off possible. It may here be mentioned, that the foundation walls must be above man high, so that the space formed under the digester, which is connected and arranged for draining off, will be large enough to easily hold the whole charge of the digester. The digester itself is filled as follows:

At one upper end is a mainvalve to shut off the digester during the operation, and a cross-nipple, carrying four other valves: of these a is connected with the boiler, b with a water pump or a reservoir, c with the leach tanks and d with the drive-over-tower. At the opposite tower end is the discharge valve e and besides in the middle of each head a nipple leading inside, carrying an angle thermometer and a manometer, also a small cock, by which during the operation some leach can be drawn and indirectly the process and its finish can be observed and determined. Either also in a head, or at the sidewalk, four more nipples are arranged next to each other, through which the heating pipes enter the inside, each of which can be shut off by a valve (f, g, h, i).

Because in the Mitscherlich process, as mentioned, the boiling operation takes much longer than in the other methods, the leach would become too much diluted, if the steam were let directly into the boiler; also the temperature, respecting the pressure in the boiler could not be as well regulated; therefore the heating of the contents of the boiler is effected by a system of pipes of hard lead, which about covers the lower third of the total inside wall. Because it often happens, that a pipe bursts during work and has to be shut out, for precaution four pipes were laid alongside, which have a total length of about 900 meters or more. The four pipe systems, which lay in four coils close to each other, pass out again at the opposite end

of the digester and every system can be shut off independently by a valve. This is necessary, because, as already mentioned, a pipe sometimes bursts inside while working. When then in this coil the steam has been shut off, the leach enters through the leak into this pipe and through it gets outside; in such case the leak can be noticed by a strong smell in the room, and closing both valves the pipe system concerned can be completely shut out. By this the duration of an operation is certainly somewhat prolonged, but the loss of leach and injury by the escaping sulphurous acid are prevented; the process can go on without delay.

The repeatedly mentioned protection of the iron digesters is effected as follows: The inside well cleaned digester is first coated with a mixture of tar and pitch, and on top of this very thin sheets of lead, so called lead foil, about 1-8 millimeter thick, are pasted in single sheets, sheet by sheet, so that the sheets are well pressed into all cavities and corners, but without tearing them. The lining is, however, done piece by piece, and only as far, as the brick lining is about to be laid, which is provided to form the main protection. For this purpose it is necessary to select quite hard, porous, acid proof, hard burned stones of the form and size of the common brick, but which are made with tongue and groove, in order to be able to make a joint as close as possible. Because it is not so much the liquid leach, which acts destructively, as the gaseous sulphurous acid, evolved in the upper part of the digester, it is most important to protect mainly the upper half of the digester; it is therefore sufficient, when the lower half of the boiler is well covered with two flat layers of brick, while the upper as a rule consists of two vaults, each 25 centimeters thick, one spanned over the other, consequently of two roll layers. For binding, best Portland cement, mixed with some sand, is used. The whole wall, especially the connection to the manholes, the sides of which must be protected by several heavy sheets of lead, must be made very carefully, because otherwise a new digester would be completely eaten up in a short time. The sulphurous acid gas under pressure eats through very quickly, indeed, when there is but one defect joint. For this reason it was tried to limit the number of joints to a minimum and lately instead of the brick form, plates were

chosen and to make the different joints as thin as possible, the form of these plates has been exactly suited to the shape of the digester, which especially at the round heads is of great importance. At the same time, in used burned plates, which are certainly much thinner than the bricks, the advantage has been gained, that the hold of the boiler becomes considerable larger and the weight of the apparatus somewhat smaller. At this point it may be mentioned that in lining the boiler, it can scarcely be prevented that the thin lead foil in some places gets damaged; by this the so necessary protection is partially missing. For this reason, lately sheet lead, 3 millimeters thick, in rolls, as large and wide as possible, is employed. These are soldered together inside (whereby naturally the boiler has to be turned), so that a perfect lead lining protectingly covers the sheet iron. On account of the weight of the lining alone it is necessary to connect the lead to the wall of the digester with screws with large heads and then to cover these heads again with plates of lead, soldered over. In selecting the sheet lead care must be taken to use but the best. Because in change of temperature lead contracts differently from sheet iron, wrinkles are often formed in it, its structure become crystalline and sags. In soft lead, when warping, it is supposed that the pores open and admit foreign substance. To make possible the employment of sheets as thick as possible, only thin sorts should be taken, and of these as many layers rolled together under great pressure, as is necessary to obtain the desired thickness.

All valves, mentioned before, must certainly also be lined with lead in all their inner parts, as this metal best resists sulphurous acid. It is also good precaution to arrange between steam boiler and digester a check-valve, so that the leach never can enter the boiler, should the pressure become less than in the boiler.

The proper process of digestion comprises the following details: After the lower manholes were closed and the wood filled in through the upper one and distributed as uniformly as possible in the digester, the two upper ones are screwed down, the main valve is opened and through this valve steam is let into the apparatus; as soon as the digester is all filled with it, the outlet valve at the lower end in back of the digester is opened and the steam is

rushed through the wood charge for about 8 to 10 hours, whereby care has to be taken that no pressure is produced in the digester. The steam condensed on the wood runs off as a dark-brown liquid, which smells like vanilla, from which is clear, that already by steaming part of the incrusts are dissolved. But the main object of steaming is to prepare the single pores of the wood for admitting the leach. The steam also displaces the air from the inner portions of the wood slices. As soon as the steaming is finished, the outlet valve closed, the steam supply shut off and the leach valve *c* is opened, the cold leach streams into the digester, the steam condenses, a vacuum is formed and each smallest pore eagerly draws in the leach, so that finally not only the spaces between the wood are filled with leach, but also the wood itself is thoroughly soaked full with leach, like sponges, whereby is prevented the rising of the wood above the level of the liquid. In this manner the sulphurous acid does not only act dissolvingly from outside, but also out from the inside. When the digester is filled with leach so far that only a small space is left at the top, so that the vapor evolved in boiling has room, the valve *c* is closed and after all packings are tightly screwed down, the boiling itself is started, by opening all four steam valves, whereby care has to be taken that the pressure in the steam boiler is the highest possible so that the digestion goes on energetically from the beginning and the temperature from its first state of 40 to 45° C soon rises to 70°, because before that chemical action of the acid does not take place. The valves at the end of the heating coils are left open in the start, that the condensed water can run off freely and before steam comes out, these are partially closed, and then altogether, when later the temperature in the digester rises too high. Thus the coil is gradually filling with water and it is avoided, that the pressure in the digester is larger than in the coil, which would be the case when the steam supply valve is closed and the outlet valve left open. Formerly it had been the first principle with every boiling operation that the pressure in the digester never should exceed 3 atmospheres and the temperature should not rise above 114°. When these limits were reached some was driven over at once, i. e., part of gaseous sulphurous acid in the digester was let off into the "drive-over-tower." But competition, declin-

(1.) OPERATION NO. 20, (IN A HORIZONTAL DIGESTER.)

	Pressure.	Temperature.	Remarks.
	Degrees.	Degrees.	
April 23, 11:30 a. m.	0.	45	
April 23, 8:00 p. m.	0.6	72	Charging: April 22, 1:30-11:00 p. m.
April 24, 1:00 a. m.	0.75	85	88 cubicmeters wood, 9 cubicmeters shavings.
April 24, 6:00 a. m.	1.00	96	Steamed: 12:00-8:00 a. m.
April 24, 11:30 a. m.	1.5	105	Acid of 5°B.; charged, 8-11:30 a. m.
April 24, 2:30 p. m.	1.75	108	In 27 hours raised to 68 degrees.
April 24, 6:30 p. m.	2.00	112	In 48.5 hours raised to 120 degrees.
April 25, 1:00 a. m.	2.5	115	In 58.5 hours raised to 118 degrees.
April 25, 6:00 a. m.	2.8	116.5	Duration 3 1/2 hours.
April 25, 9:00 a. m.	3.0	119	Maximum pressure, 3 atmospheres.
April 25, 12:00 m.	2.8	120	Maximum temperature, 120 degrees
April 25, 3:00 p. m.	2.25	119	Cellulose, very good.
April 25, 10:00 p. m.	2.1	118	

(2.) OPERATION NO. 101, (IN AN UPRIGHT BOILER OF ANOTHER FACTORY.)

Started	Heating.	Pressure.	Temper.	Pressure.	Temper.	Remarks.
Aug. 2,	4:30 p.m.	Atmosph.	Deg.C.	Atmosph.	Deg.C.	
		Below.		Above.		
Aug. 2,	4:30 p. m.	0.	30	0.	40	Charged Aug. 1, p. m., with wood of mixed thickness
Aug. 3,	9:00 a. m.	0.3	87	0.3	87	Steamed Aug. 2, from 1 a. m. to 1 p. m.
Aug. 3,	11:00 a. m.	0.4	89	0.3	89	Leach of 5.5° pumped from 2.45 to 4.45 p. m.
Aug. 3,	1:00 p. m.	1.0	96	0.4	95	Height of leach in basin, 115 mm.
Aug. 3,	3:00 p. m.	1.2	102	1.	99	Left, 5 mm.

Aug. 3, 6:00 p. m.	1.3	106	103	In 28 hrs. raised to 108 degrees	9 hours.
Aug. 4, 6:00 a. m.	2.4	120	115	In 30 hrs. raised to 114 degrees	"
Aug. 4, 8:00 a. m.	2.4	122	116	In 37 hrs. raised to 118 degrees	26 hours.
Aug. 4, 10:00 a. m.	3.	122	117	In 63 hrs. raised to 118 degrees	"
Aug. 4, 12:00 m.	3.	122	117	Total,	35 hours.
Aug. 4, 2:00 p. m.	3.	122	117	Discharged Aug. 6, a. m.	
Aug. 4, 4:00 p. m.	3.	122	117	Stuff: Very nice.	
Aug. 4, 6:00 p. m.	3.	122	117		
Aug. 5, 6:00 a. m.	3.	122	117		
Aug. 5, 7:30 a. m.	3.	122	117		

This upright boiler was 4 meters in diameter and 9 meters high, charged with 60 cubic meters wood, which was cut in slices.

(3.) OPERATION NO. 207, (IN A HORIZONTAL BOILER OF A THIRD FACTORY.)

	Pressure.	Temperature.	Remarks.
	Degrees.	Degrees.	
June 2, 6:00 a. m.	0.	40	Charged June 1, from 1 p. m. to 3:30 a. m.—60 testmeter.
June 2, 11:00 a. m.	0.5	73	Steamed from 3:30 a. m. to 3:30 p. m. No pressure (102 degrees).
June 2, 4:00 p. m.	1.0	97	Acid of 5.5 degrees B pumped 4:30 p. m. to 6 a. m.
June 2, 12:00 m.	2.0	103	In 18 hrs. raised to 108 degrees.
June 3, 5:00 a. m.	2.7	116	In 25 hrs. raised to 118 degrees.
June 3, 7:00 a. m.	3.0	118	In 55 hrs. raised to 118 degrees.
June 3, 12:00 m.	3.0	118	Total, 30 hours.
June 3, 10:00 p. m.	3.0	118	Maximum pressure, 3 atmospheres.
June 4, 8:00 a. m.	3.0	118	Maximum temperature 118 degrees.
June 4, 1:00 p. m.	3.0	118	Stuff: Nice.

ing prices of the cellulose, and the endeavor caused thereby to produce more and more with the same plant, have induced the manufacturer to exceed these limits, not only to gain time in charging and discharging of the digester, but also to shorten the operation of boiling as much as possible. By careful experimenting the author has found that without endangering the product, 3.4 to 3.5 atmospheres and temperature as high as 120° Celcius may be safely applied. By this whole period of boiling, which formerly required 75 to 85 hours (warming up included), has by and by become reduced to 58 hours and less, of which but 32 hours are required by the process proper. It must be mentioned in this place, that the kind of heating pipe system is of much importance in regard to the duration of the process, as the length of the pipes, the strength of its walls, keeping it free of deposits of sulphate of lime, all have an effect in hastening or delaying the delivery of heat, and also the digesting. It is well to take care that neither pressure nor temperature go down before the operation is finished, but be kept uniformly high, as much as possible, at least towards the end. This certainly requires sharp control. To give a clear illustration of the run of the digesting process in its different stages and at the same time to get acquainted with the time necessary between the charges, examples from practice are given on the preceding page which contain the notes about any operations as written down for control in the so-called "boiling-book" of every cellulose factory.

Examining and comparing these three examples it can be clearly seen that the warming up until the beginning of the digesting process requires from 18 to 28 hours time and that the proper digestion in these three examples takes almost equally long, i. e., 31.5, 35 and 37 hours. The previous steaming has required 8, 10 and 12 hours time. The charging of wood and acid was also varying according to local conditions. Including these manipulations; from charging to blowing off were required, in the first factory 80½ hours, in the second 87 hours, and in the third 72 hours. To this time has to be added the blowing off, letting off the leach, cooling off and washing, also discharging and revision of the boiler, to be done any time, which labors require at least 18 to 24 hours, so that for the total duration of one operation 90 to 100 hours

have to be calculated, consequently only 7 to 8 operations can be made per month with one digester.

When employing sufficiently strong leaches, i. e., rich in free sulphurous acid, when other circumstances are favorable, especially in larger works, with Mitscherlich boilers 11 to 12 operations may be made per month, but the leach must contain about two parts free sulphurous acid for one part combined.

In regard to the controlling of the process and especially determining its end, this can be done only by drawing from the stop-cock at the gauge-nipple some of the leach and testing it. For this purpose a 200 mm. test tube is filled to about 60 mm. with commercial ammonia solution, and holding the tube with a clamp, some of the hot leach from the stop-cock is added and then the liquids well mixed. The tube is then set aside in a test tube stand. The ammonia combines with part of the sulphurous acid of the bisulphite of lime, whereby the resultant monosulphite of lime becomes insoluble, separates and deposits at the bottom as a white powder. The higher this layer of precipitate is the more bisulphite of lime is contained in the leach therefore the less it has been used up. Because in practice the duration of each operation is almost the same, it is sufficient, when beginning, to take samples in the second half of the process, from time to time. But the less the precipitate appears the oftener the tests must be made; towards the end this should be done every quarter of an hour, as the precipitate must not be allowed to entirely disappear. The nearer the end the quicker and coarser the precipitate; its color becomes yellowish, and smell changes, is not a pungent, and the liquid becomes sticky and darker. When the precipitate appears but 6 to 8 mm. high, the operation is finished and the digester is blown off. After the water is started in the drive-over tower the main valve of the digester and valve d are opened, so that the gaseous sulphurous acid can go over to the tower through a lead pipe, which for cooling off is let in a coil through water. As soon as the aqueous solution formed there reaches 4°B, it is run off into the acid-tank. As at times a solution of from 10-12°B is obtained, this blow-off acid is quite useful to the manufacturer; he improves with it the strength of a leach necessary in the next operation. As soon as the pressure in

the digester has become reduced to one and one-third of an atmosphere, which takes place in a few hours, the discharge valve is opened and the leach, still under some pressure, is let off through a lead pipe, at least 100 mm. in diameter, into the leach basin, about which more will be said later on. When the pressure in the digester is altogether reduced and the leach run out, the discharge valve is closed and the boiler filled through water valve d to about one-half with cold water, during which manipulations both upper man holes are opened. Through these, by means of a pole and a small arrangement fixed to it, the first real sample of the finished cellulose can now be taken out to see whether the operation was a success, and accordingly to make disposition for the further working of it. But in case of a failure a repeated charging of acid and repetition of the boiling operation would not yield a better result, therefore the charge has to be taken out at all hazards.

Letting in cold water is mainly for the purpose, not only to somewhat cool off the hot mass and the digester itself, but also to free the material from the brown leach as quickly as possible, thereby giving it a preliminary washing or rather, rinsing out. After this first washing is let off, as second rinsing is done in the same manner, but then the lower manholes are at once opened, and poles are pushed through to the upper manholes, so that a draft through the digester is secured and the mass is cooling off as much as possible.

As soon as it can be done, two persons, mouth and nose covered with sponges, must go into the digester and commence discharging with wooden shovels and picks. This on account of the strong smell and great heat still prevailing in the apparatus is not easy work: the laborers must often shift and naturally, the labor of discharging, done by contract, must be well paid for. This work, however, is not really injurious to the health of the laborer, as men who were at it for years never showed any symptoms of sickness.

Not only for the Mitscherlich system, but for all other processes a method has lately been recommended to remove the sulphurous acid as much as possible before the stuff leaves the digester. This is the method of Carpenter and Schulze in Berlin, heating the leaches after fin-

ishing the operation of digestion, by driving compressed and heated air by a blower through a perforated pipe into the boiled mass, whereby the stuff becomes fibered and at the same time are formed resulting combinations which otherwise do not form before draining, after leaving the digester, under the influence of atmospheric air. In the upper part of the boiler is another perforated pipe, through which air and sulphurous acid can be drawn off.

When the cellulose is removed from the digester, and the boiler is swept, if necessary, the heating pipes are then knocked with wooden hammers to remove the sulphate, often depositing on the pipes in considerable thickness, because as a poor conductor of heat it very much injures the heating capacity.

Every single pipe system must be separately tested to see whether it is tight, does not let through steam, and also, whether by leach having entered and formed sulphate (gypsum) inside, it has not become stopped up. In the first case the leak must be corked or a new piece of lead-pipe must be set in, which can be rapidly accomplished, if the pipe pieces are not soldered but screwed together with bronze flanges. When the pipes are stopped up, muriatic acid is filled in and slowly driven through with a little pressure of steam, finally after every operation the whole lining must be well looked over, especially the top. The heat prevailing inside soon dries up the face of the wall completely except at the spots where the acid has penetrated the joints where it trickles out again as moisture and thus shows plainly, where it is most necessary to do the joints over. If this important matter is neglected the complete destruction of the digester will soon be caused. The saving of time at this point can therefore not be recommended.

In regard to using hard lead for heating pipes, it must be finally remarked that it is followed by a number of inconveniences which long ago made desirable a substitute, and finally led to the use of copper, the resistance of which against sulphurous acid was not regarded with much favor. On account of its greater power of resistance the hard lead pipes were first chosen, which in consequence of the steam going through under pressure in long coils, have to stand greater differences of temperature. But for that lead is very little suited. Being an imperfectly elastic

body, it does not contract to its original form, when on account of previous raising of temperature it had suffered expansion. Moreover there are occasionally stronger and weaker layers, bends, which in pipes becomes suspicious as constrictions and dilations, also cracks, through which leach and stuff are entering and causing partial or total stopping up. All these influence the heating effect and prolong the duration of an operation. This is still exaggerated by the layer of separated lime salts, deposited around the heating pipes, being a poor conductor of heat, and which cannot be as quickly and thoroughly removed from the soft metal which is easily injured. Lead is in itself little suited for heating pipes, because it is not a good conductor of heat, and the pipes, in order to be durable, must be of considerable thickness. Not one or all these disadvantages however is met with in copper. Copper pipes, by virtue of the great firmness of this metal, can be made quite thin, at a thickness of wall of from 3 to 4 mm., and besides copper is an excellent conductor of heat. Changes of temperature do not cause the bad effects, as with lead, and the coil does not form one single stiffness, but is composed of a number of sections, 4 to 5 meters long, connected by couplings of acid proof bronze, which at any place may be exchanged at pleasure. The resisting capacity of copper against sulphite leach has proved to be greater, as in the first operation it gets covered with a black coating of the oxydes of copper, which very likely is produced by the action of the glyose, present in the leach and which prevents further action. On account of the greater heating capacity of copper pipes less of them are necessary for one boiler, than lead pipes; for the cubic-meter volume about 2.5 meter of pipe. They are varyingly arranged, according to whether they are intended for horizontal or upright digesters. In the latter they are run along side the wall, in the former at the lower side in coils measuring about 1-5 of the wall and the water of condensation is removed by suitably arranged traps.

To complete this treatise on heating pipes, not published until after the end of 1894 in the *Papier Zeitung*, the author is in the position to state that in 1886 he was negotiating about the furnishing of copper pipes for a Mitscherlich digester, with a cellulose factory in Steyer-

mark, which already in 1885 or earlier has furnished such pipe systems to other factories, which were very well satisfied with its work.

An operation as described above, yields about 10,000 kilos of finished dry cellulose and according to several experiments by the author for 100 kilos cellulose about 0,956 volumeters or 0.62 cubic meters of wood (pine) are needed on the average, which is exactly accordant with Mitscherlich's statements, who calculates 0.63 cubic meters of wood for 100 kilos of cellulose. At this the relation between testmeter and volumeter is not, as generally stated in books, accepted 7:10, but 65:100, which latter figures have become fixed by practice after many trials.

Every cellulose factory, according to its working method and the kind of wood mainly used, will certainly, in regard to the average yield in cellulose, obtain a percentage number, somewhat differing from the results of other factories. So for instance, according to an older publication at the Weissenborn factory they figure 2,400 kilos cellulose for 12 testmeter, consequently 200 kilos for 1 testmeter and 140 kilos for 1 volumeter. This result can, on account of being so high, be accepted as correct only for very good and barked material. The specific gravity of the air dry pine wood is 0.47, consequently 1 testmeter weighs 470 kilos. One cubic meter, i. e., one volumeter of trimmed pine wood weighs 320 kilos, consequently 1 volumeter would be 0.68 or about 0.7 testmeter, which however, is somewhat too high, according to the author's experience. The difference is by no means unimportant, because as a rule, the incoming wood is piled up and accepted per volumeters, but figured and paid per festmeter. In the run of the year a considerable number of meters may thus be paid over.

From the balance sheets of a southern German factory it is learned that per cubic meter pine would equal 156 kilo air dry cellulose.

A northern German factory worked up in one year 52.10 volumeters of wood and produced in the same period 715,000 kilos of stuff at large (I. II, III,) consequently 1 volumeter would yield 137 kilos air dry cellulose, which keeps the middle between the above mentioned figures.

The cellulose factory Waldhof, before its new plant

was started, had a daily production of 1,400 centner dry. The consume of wood amounted to 170,000 testmeters per year. The yield of cellulose, amounting to 25,000,000 kilos per year it follows, that for 1 testmeter 148 kilos must be figured, or for 1 volumeter 104 kilos of cellulose. Supposing now, that these 104 kilos of cellulose were obtained from 1 volumeter embarked, equal to 0.8 volumeter of barked wood, the yield from a full volumeter of barked, good wood amounts to 130 kilos of cellulose,

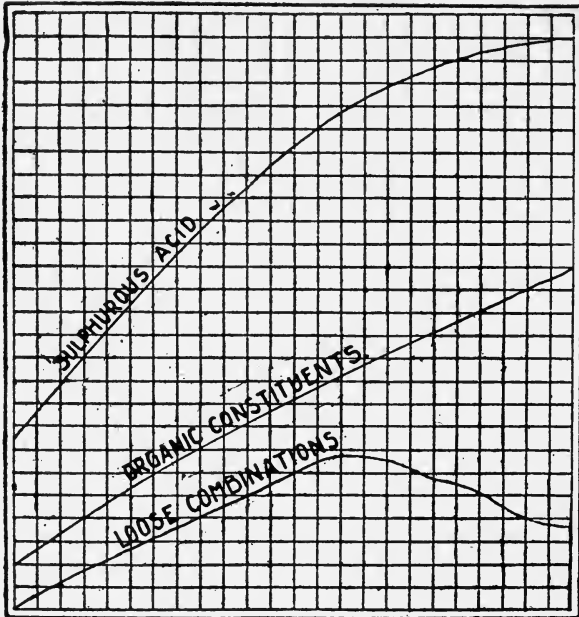

Fig. 49.

which does not differ much from the Weissenborn result.

About the proper occurrence inside of the digester, during the process of digestion up to the present comparatively few observations have been made. A. Herr Nils Pedersen has in No. 19 and 34 set 1890 of the *Papier Zeitung* published quite interesting researches, which in this volume, serving more practical purposes, could not be together admitted. Only the final results of the inves-

tigations about leaches, which were taken in certain instances during the operation, shall here be regarded as the figures obtained were used in a graphical description, which gives a plain picture of the decomposition of the wood in the digester. In both figures, at the base are marked horizontally the hours required by the process, after the temperature in the digester had reached 105°; the ordinates, i. e., the vertical lines give the per centage; the

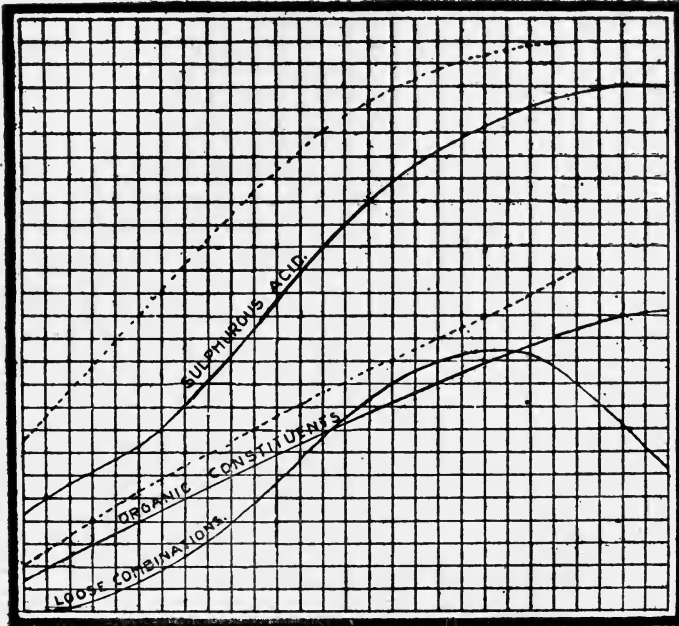

Fig. 50.

temperatures of the digester at the different times are marked at the upper horizontal line.

Curve I shows how the sulphurous acid gradually is forming combinations with the organic constituents. Curve II shows how the organic constituents are accumulating in the course of time, expressed in per cent.

Curve III shows how the loose combinations first are continuously forming, up to a point from where the curve descends, consequently decomposition is commencing.

In serving an explanation to this, the investigations have proved that in the leach part of the sulphurous acid is existing in a loose combination, which is decomposed by boiling. By adding a stronger acid, for instance, sulphuric acid, the decomposition ensues still easier. The same observation was made by the author years ago, when, for the purpose of rendering the leach inoffensive it was evaporated in large open vessels and for the more rapid driving off of the sulphurous acid, sulphuric acid was added with success.

The curve indicating the organic constituents is ascending in almost a straight line, in the beginning so also is the sulphurous acid. But it is remarkable that where the loose combinations are beginning to get decomposed the curve of the sulphurous acid does not ascend as rapidly as before, because here not only the free sulphurous acid is acting on the organic constituents, but also the sulphurous acid, split off the loose combinations, but already counted in once, as combined with organic constituents.

In the second figure the results of the analysis of a second leach, richer in lime, are entered, just as before and for better comparison, the curves of the first figure are here repeated in dotted lines. Curve I represents both loose combinations together. As appearing from the illustration, also the two other curves deviate very little.

These researches by Mr. Nils Pendensen, according to Dr. Frank's statement, were invited by and built upon preliminary investigations, which he had made sometime ago and which he has published already in the year 1888.

Corresponding to the order in the chapter about leach making, the digesting process of Ritter-Kellner shall now be briefly mentioned here. In this case two upright boilers are used, lined with small plates of lead, held together by rings and bands of lead, which have two perforated bottoms, between which the wood is filled in. The digesters are connected by pipes in the manner shown in Fig. 51, taken from the letter of patent. A and B are two iron vessels with inside lead lining, vessel C contains the solution of sulphurous acid, C1 fresh water. A pipe 1 leads from C to C1 by branches 2 and 3 with regulating valves 5 and 6 into both digesters and enters a little above the grates a and b, which keep the wood immerg-

ed into the liquid. The pipe 4 is to the right communicating with a steam boiler and a vessel with sulphurous acid. Pipe 4, which to the left at c ends into the gutter cl, has two branches 7 and 8, which enter the bottom of the boilers, where they are closed with regulating valves 9 and 10. Besides pipe 4 has two branches 11 and 12, with the regu-

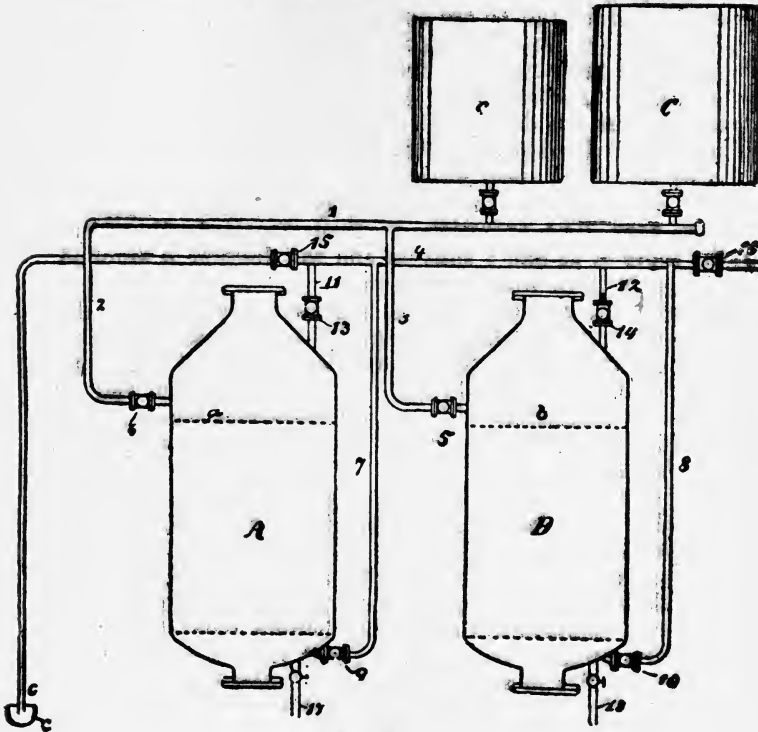

Fig. 51.

lating valves 13 and 14, and above and into boilers. To discharge the digesters, i. e., to let off the leach the outlets 17 and 18 are provided. The work is carried on in the following manner: Suppose boiler A to contain wood, which is exposed to the action of twice used acid solution, while digester B is filled with fresh wood. Then the valves 6, 9 and 10 are opened, while 5, 13, 14, 15 and 16 remain closed; the fresh leach therefore runs through

pipe 7, 4 and 8 into digester B. When A is filled with fresh pipe 7, 4 and 8 into vessel B. When A is filled with fresh leach, valve 6 is closed and valve 14 opened, whereupon steam enters through the pipes 7 and 8 into both digesters and the wood boils.

When the boiling is finished, valve 16 is closed again and valves 14 and 15 are opened; the sulphurous acid and the steam are blown through pipes 12 and 4 into the gutter c, or for recovery they are regenerated in suitable apparatuses. Afterward all liquid is removed through outlet 18 from the digester B, in which nothing is now contained but decomposed wood. The solution from digester A by admitting fresh water from vessel C1 is then driven into digester B in the former way and is now solution once used. The operation is then repeated, thereafter the pipes 2, 11 and 7 shut off and the digester A emptied and again filled with fresh wood.

From there the operation repeats, only the two digesters exchange rolls. In place of two digesters, several may be employed at the same time, whereby it would be possible to use the solution four to eight times and to use it up completely. The single operations become then considerably shortened and a product is obtained, excellent in every direction.

When especially white cellulose shall be made, the wood is soaked with leach in the digester and before heating, by means of a pump sulphurous acid is forced in until a pressure of at least two atmospheres is reached. Not before then either steam, or steam mixed with sulphurous acid at a temperature above the boiling point is let in, until the pressure has reached about from 3 to 5 atmospheres. By this in the first state the decomposition of the wood, in the second the bleaching of the fibre is effected. The stuff becomes white, does not contain any hard constituents and can be further worked without first passing a knot catcher. The boiling process requires about 14 to 18 hours, with low pressure; however, it may be prolonged to 36 hours.

Dr. Kellner amply describes his own process of boiling in set, 1894 page 2586, as follows:

Although owning the first patents for rotating digester, for the reason that my first manufacturing was done with such, I have, however, soon gone over to the by far more

practical form of the upright fixed cylinder. My digesting apparatus since consists of an upright fixed cylinder, which on top and below carries a large manhole, fastened with lock-screws.

This boiler, in the beginning of my method, was lined with sheets of lead, which were clinched to the boiler, or soldered to strips of hard lead, which, in swallow-tailed rabbets between the sheets of the boiler, where they met, were connected with the iron thermo-chemically. D. R. P. 34074-1884.

In Fig. 52, for example, C is the strip of hard lead, A the boiler-wall, B the lead lining, J the clinche to connect the boiler sheets A to A'. Or the lead sheets are with easy fusible metal directly soldered to the digester walls. D. R. P. 3725. As not in every locality experienced lead burners can be had, I have tried from the beginning to do away with the lead in the digester.



Fig. 52.

My first patent regarding this was applied for in 1887 by the Messrs. Jung and Lindig to insure profound secrecy, and presented in an altered condition two years later, having been refused the first time. My main object was to effect the double decomposition between the sodium silicate and the calcium bisulphite, at the end of which reaction sodium sulphite and calcium silicate are formed. The latter serves to close the pores of the sulphurous acid resisting substances which are made into a mass with liquid glass. Digesters coated in this manner have proved to be very satisfactory, although very many factories have departed from this process, and returned to the old manner of lead coating.

In order to prevent the lead from being attached, should a leak in any part of the mass occur, I have recommended, as illustrated in Fig. 53, to cover the digester A with a jacket B of thin tin and to fill the interlying space with the heavy residue obtained from the petroleum refineries.

Into the outer jacket m enter the pipes m² and m³ for

m and, outlet of the liquid residues and m1 for emptying. In this manner the boiler also receives heat from outside, and forms at any place, laid bare by cracking of the inner lining, a protecting coat of mono-sulphite of lime. This jacket, against the one proposed by Soloman, has the ad-

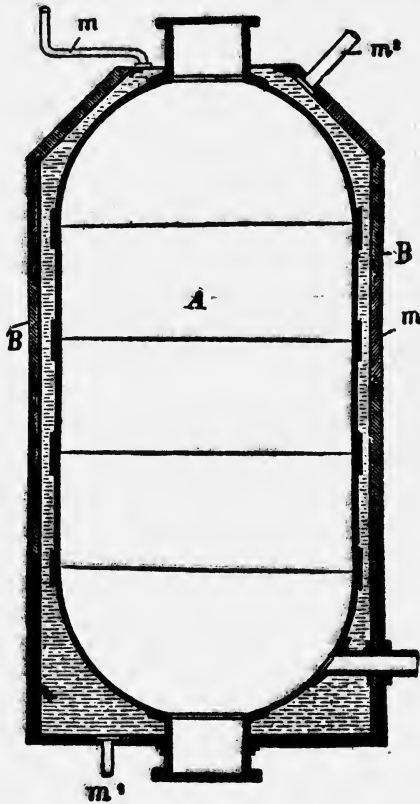

Fig. 53.

vantage, that inside of a few hours it can be completely removed in case of repairs becoming necessary, and that danger of explosion is altogether excluded. In the case of any rivet leaking, the sulphurous acid leaking out, escapes through the hot oil in the form of gas, which is at once noticed.

With digesters, the jacket of which is heated with steam, a dangerous moment is prevalent, as the space between boiler and jacket is entirely without protection against sulphurous acid and therefore injuries to the inner digester cannot be noticed any sooner, than when also the jacket has become defective—which may cause deplorable catastrophes, as will be told later on.

The heat required in boiling, I introduced by direct steam, as I have departed from indirect heating for the reason that the heating coils get rapidly covered with mono-sulphite of lime, consequently do not well conduct the heat and carry no end of dirt into the stuff. It is indeed not necessary to work with indirect steam, when at liberty, to prepare the leach in such concentration, that it still has the concentration required for boiling, after adding the water of condensation from the steam. Such was easy, because in my leach making apparatus I can produce leaches of to 7.5°B without difficulty, while Prof. Mitscherlich could produce but weak leaches in his towers.

In regard to the boiling itself, according to my method it is not necessary to steam the wood previous to the treating with sulphurous acid, thereby diluting the latter. After charging the boiler the leach is at once let in by a pump through a pipe put through the open manhole, in such quantity and concentration that its volume is so much increased by the water formed by the condensed steam that when a temperature of 105°C is reached the whole of the wood is covered with liquid. The concentration is at the start made high enough so that after dilution with the water of condensation just that concentration results with which the boiling is desired to be carried through.

In this manner at the beginning of the period decomposition exactly the same conditions and proportions exist, which are arrived at with indirect heating, but with the difference that much time is saved, because by the use of large steam pipes a large boiler, producing about 6,000 kgr. stuff, is in $1\frac{1}{2}$ hours brought to 105°C , a result which with indirect heating requires several hours.

I then heat further to about 109°C , then shut off the steam and leave the wood about 3 hours under the influence of the hot leach, so that it can penetrate every particle of wood, before the temperature is further raised. In this manner I avoid all formation of splinters. This pause,

which in my method is called "stand-still," can be modified according to the nature of the wood and its degree of dryness. Absolutely dry wood does not require any stand-still, or less prolonged stand-still than damp wood, because the leach can penetrate quicker on account of the capilarity. I then raise the temperature quickly up to the desired point, 120-138°C, again shut of the steam and repeat this supplying of steam at regular intervals.

To facilitate the entering of steam and to eliminate the hydrostatic pressure in the digester, I let off from time to time through the so-called off-gas-valve provided at the upper neck of the boiler, some leach (sulphurous acid mixed with steam) into the condensating-apparatus, peculiar to my process.

In fig. 54 such condensing arrangement is sketched. Sul-

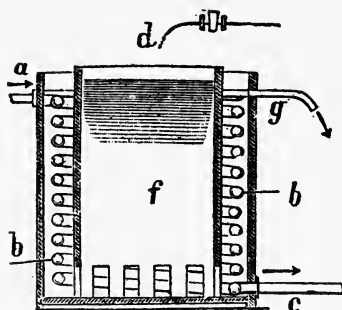

Fig. 54.

phurous acid and steam enter at a into the lead pipe coil b, condense there, and flow out at c as liquid sulphurous acid. The cool water runs through pipe d into the middle space f, rises at the bottom between the walls and around the coil and leaves through the over run pipe g.

During the boiling samples are taken from time to time and these have the following characteristic signs: In the beginning the leach is wine-yellowish and somewhat turbulent, then it gradually becomes darker and clearer. After a few hours I commence to test the free sulphurous acid volumetric with a normal iodine-solution.

It is my special discovery that the sulphurous acid during the boiling does not, as Tilgham and others have supposed, become oxydized into sulphuric acid, but enters

in organic combinations, and forms organic sulfinic combinations. And my discovery it is also that the sulphurous acid, keeping in this organic combinations does not show the iodine reaction—therefore the still uncombined sulphurous acid can be estimated by titration with iodine during boiling.

When making sulphite-cellulose I have endeavored to produce a stuff giving general satisfaction in every way, consequently felting tough and firm enough to bind wood pulp or earth for ordinary paper and which at the same time shall be also opaque, soft and very easy bleachable, and which could be worked into finer and finest papers.

By my process it is possible to produce just as tough, but there certainly is just as difficultly bleachable cellulose, as by those processes, which work with low pressure and use indirect steam.

The reason why the fibre produced at low pressure and with direct steam is firmer is that the inter-cellulose substance, i. e., that body which fills out the capillary of the fibre, the cave of the cell, has not diffused through the walls of the cells, because the boiling was done under conditions which do not permit diffusion. Because when the concentration of the leach in an organic substance outside of the cells is equally high with that part which has entered the cells there is no occasion for the latter to force its way through the membranes; if however, when boiling with direct steam, the leach outside of the cell, because of the water of condensation, becomes diluted, then the concentrated solution contained in the cells diffuses through the walls of the cells.

The work is performed as follows:

TABLE FOR BOILING.

Charging the boiler with wood	10 min.
do with tramping down	30 min.
Filling in leach	20-30 min.
Making fast the upper manhole	15 min.
Steaming up to 109°C.....	1 hour, 30 min.
Stand-still	3 hours
Steaming to the desired temperature	$\frac{1}{2}$ hour
Duration of boiling with letting gas off leach and several times supplying steam	8-14 hours
Gasing off into concentration	1 hour
Blowing out	15 min.

Admitting water and discharging	30 min.
Cleaning the digester	1 hour
Total	about 21 hours.

Therefore, including small repairs of the digestors, one operation can be performed every 22 to 30 hours.

Such repairs are reduced to a minimum, because besides the manholes, the boiler has but one opening for admitting steam, one for letting off leach, one for gasing off, and one to arrange a thermometer and stop cock for taking samples.

The next described apparatus is designed to avoid losses of sulphurous acid in boiling, as well as defiling the stuff with precipitates of mono-sulphites.

In the sulphite processes as a rule the cold leach is filled in together with the wood, and by inner or outer heating gradually raised to the required temperature, at which the decomposition of the wood in its fibres takes place. By this heating up a considerable amount of mono-sulphite of calcium is generally separating from the leach, very likely in consequence of a part of sulphurous acid being set free by the heating, and acts disadvantageously in that it forms crusts upon the heating coil or upon the inner face of the digester walls, as also because it discolors the stuff, which afterwards requires stronger bleaching. To meet this disadvantage according to the present invention (America patent No. 542,932 and Austrian patent No. 33,685 and 56,889) the leach is first heated outside of the digester in a special heater, whereby the separation of the mono-sulphite takes place outside of the digester and is then let over by the digester filled with wood. Thereby the sulphurous acid, being set in the heating of the leach, is condensed in a coil-cooler and used again as solvent for the separated mono-sulphite.

Fig. 55 shows a vertical cut of an upright heater with condenser. It mainly consists of a vessel a with steam-heating-coil b, into which the steam enters at c, while at the end of trap e is connected. Both above and below is also a thermometer t. Below at the vessel there is an outlet and cleaning valve n. The leach to be heated enters at f into the vessel and leaves at g. On top the vessel is connected by pipe h with the one end j of a coil condenser, while the other end j1 leads to the reservoir for the product of condensation. The condensor k consists of

two concentric vessels, of which the inner has openings below. The condensing medium flows through pipe *l* in the inner vessel, rises in the space between the inner and outer vessel and runs off through pipe *ll*.

To facilitate the separation of the mono-sulphite and at the same time to keep it floating during heating, a stirring arrangement is provided in the vessel (not represented in the sketch).

The method proceeds as follows: The heater is filled with leach and is heated above the boiling point, with the stirring arrangement steadily going on. When this point

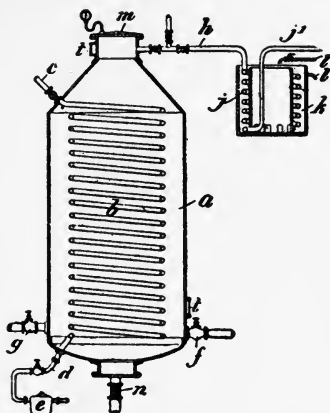

Fig. 55.

is reached the stirring is stopped, the separated mono-sulphite permitted to settle, and the hot leach transported to the digesters, already charged with wood. The cooled gases, principally consisting of sulphurous acid are liquified in the condenser and let into the storage tank, into which are also let the gases from the digester, after finishing boiling. After discharging and previous to re-charging the heater, the liquified sulphurous acid is let from the reservoir into the heater, to dissolve the separated mono-sulphite deposited at the bottom, when cold leach is again filled in and heating started anew.

Every process employed in the manufacture of cellulose and named after its inventor, prescribes for the proper boiling of the wood a certain way, which, although in the principle the same, every different factory shows more or

less variation, suitable to local conditions, the experience of the manufacturer or manager and master of boiling, the nature of the wood worked, and other like conditions.

In the following we describe some such varying in particulars more or less from each other, but all practically tried methods of boiling:

1. The digester is heated, the slower the better, up to 116°C , and about 2.8 atmospheres, and then the steam is shut off and a stand-still follows, which when desired can be extended to 8 hours. The pressure, at the beginning of the stand-still rises somewhat and then gradually falls and when necessary, by letting off steam, is brought down to at least 2 atmospheres. Then follows renewed steam supply up to the temperature of 136° , 4 to 5 atmospheres pressure, and at this the digester is kept, until according to looks, smell and strength of the leach in sulphurous acid the boiling may be regarded finished, when the steam is blown off as quickly as possible. The duration of the whole operation according to this method amounts to 18-22 hours and is principally suited for cellulose designed to be bleached.

2. The digester is within about 3 hours brought to 105° and then left at stand-still for 3 hours more. After that it is blown off down to 3 atmospheres and the heating with steam continued until up to 125°C . Blowing off steam is repeated, until the temperature goes back to 120 - 125° and then the process is finished under continuous supplying of steam in about 10 to 12 hours at 130°C . Duration of the operation, 14 to 18 hours.

3. Heating up to 105°C and $2\frac{1}{2}$ to 3 atmospheres within 3 to 4 hours. Then stand-still, which according to requirement and use lasts 1 to 3 hours; then continuing heating, so that at 108°C about $2\frac{1}{2}$ to 3 atmospheres, at 115° about 3 atmospheres, at 123° about 4 atmospheres, at 130° about $4\frac{1}{2}$ atmospheres, at 135° about 5 atmospheres of pressure are obtained; the highest temperature permitted is 135 to 140° ; if rising the steam-supply must be shut off. Finishing of the operation at 0.56 to 0.5% of sulphurous acid; which should be accomplished in about 8 to 9 hours after the stand-still. Duration of operation, 10 to 14 hours.

Against those mentioned above, the Ritter-Kellner method possesses the following peculiarities and advantages:

1. The possibility of employing in the dressing of the wood, a diminution in the sulphite process as well as in the soda process advantages; first of a uniform diminution and with the consequent uniform product, and second, of the rapid penetration of the particulars of wood with the leach, and consequently stuff free of splinters; another advantage is the shorter duration of boiling.

2. Employment of a leach, consisting of a double salt of the sulphurous acid: Calcium-magnesia-bisulphite and produced by using "Dolomit" in preparing the leach. The advantages are, first, a less precipitation of lime in the digester, because the monosulphite of the magnesia is soluble in water (the combination of lime, however, is decomposed by the magnesia during boiling) and, second, whiter, tougher stuff, because the sulphurous acid is longer retained.

3. Employment of a leach containing more than 2 molecules of sulphurous acid to 1 of molecule of the base base (the composition of which is consequently nearer to a hypothetical "Trisulphite"). The advantages are, first, the precipitation of lime in the digester is completely eliminated, because according to the Mariott law during boiling, the molecule SO_2 required in the dissolving of Ca SO_3 , on account of the pressure produced by the SO_2 in excess, cannot escape into the vapor space of the digester; second, the possibility to produce at liberty absolutely white and cottonlike cell stuff, little transparent and easily bleachable, consequently most valuable for the manufacture of fine and finest papers.

4. The method to submit the sulphurous acid containing gases, coming from the furnaces, before entering the absorption apparatus to an energetic cooling. The advantages are the possibility to produce highly concentrated solutions in relatively small apparatuses, because as well known, the capacity for absorption (efficient of dissolving) of a liquid for gases increases with decreasing temperature.

5. The method to force these cold gases by artificial pressure (draft) through any number of absorption apparatuses. The advantages are, first, complete absorption of the sulphurous acid, consequently greatest effect; second, independence of air currents and outside temperature; third, constantly uniform production in qualitative

and quantitative respect; fourth, no injuring of neighboring vegetation; fifth, production of possible highly concentrated leach.

6. The employment of upright cylindrical digesters with combined direct and indirect, or only direct heating. The advantages are, first, rapid boiling, because there is no loss of time by a warming up of long duration; second, excellent circulation; third, no hard lime deposits at the heating pipes; fourth, convenient tending of the digester and rapid charging and discharging.

7. Employment of rotating digesters with direct heating. The advantages are, first, for smaller plants simpler attending; second, cottonlike stuff.

8. Different manners of lead lining, and the employment of water-glass for the production of acid-proof protecting mass. The advantages are, first, rapid execution of repairs; second, jointless lining.

9. The lining of this protecting mass with plates of hard glass. The advantages are, first, greater cleanliness; second, instant visibility of perhaps occasional cracks of the lining through the glass (as brown lime-spots); third, greatest durability; fourth, best closing at the joints.

10. The method to control the proceeding of boiling in its progress by titration with iodine solution. The advantages are, first, the possibility to exactly determine the ever standing of the transformation; second, to be able to produce several qualities, tough and soft, as desired.

11. Method to recover the sulphurous acid retained in the digester after finishing boiling, by conducting it mixed with steam, through condensing coils. The advantages are, first, recovery of about 18 to 20 per cent of all the sulphurous acid employed; second, no molestation of the neighbors; third, supply of aqueous sulphurous acid for the production of possibly strong leaches; fourth, removing of occurring sulphate crusts in the absorption apparatuses.

12. Method to employ the sulphite digester under pressure (blow-off method). The advantages are, first, very rapid discharging, because it is not necessary to wait until the pressure has gone down; second, open stuff can be easily washed out and with little water.

The other sulphite methods, already mentioned in the chapter of leach-making, according to Hager, differ in

their principal characteristics of the digesting process as follows:

Ekman boils in a cylinder vessel, surrounded by a steam jacket, lined with lead and turning on side pins for charging and discharging. The digester about 1.3 meters wide and 4 inches high after being charged with wood is filled with the leach until the wood weighted with perforated sheets of lead is covered by it. By steam from a separate boiler a special over-pressure is then produced in the jacket according to the following rule: Within the first two hours the pressure in the inner vessel should be raised 0.7 atmospheres, in the next two hours about 1.4 atmospheres per hour, in the next hour by one, and in the two following by 0.7 atmospheres each. With this final pressure of 6 atmospheres the digester is left, until a peculiar smell of the vapor let out by a valve, or a sample taken, indicates the end of the process. The steam is then blown off, the liquid drained off through a leaden strainer arranged at one end, and finally after turning the digester the contents are dumped, to be washed or ground in the ordinary manner. The product by this method is claimed to yield 32.68 per cent of wood charged green or 40 per cent of air dry boiling wood.

Francke in Molndal employs a horizontal cylinder vessel of steel-plate of 2.2 meters diameter and 12.5 meters length, with a 6 millimeter strong lead lining, forming a vessel by itself, soldered together from sheets of lead, which is fastened to the outer vessel by rings of brass in distances of 1 meter. The digester, which is slowly rotating (once in 10 minutes) and carries side catches to lift the wood, rests with wide flanges on rollers, and receives its rotation by a worm-movement. The digesters are first filled to about three-fourths height with pieces of wood, and then with solution of from 4 to 50°B so that the wood is well covered. The boiling is effected at a pressure of about 3.5 atmospheres, produced by steam, entering through a hollow pin provided at one end and regulated by a reduction-valve.

When the boiling has lasted about 11 hours, some of the mass is blown out through a leaden cock for sample and this sampling is repeated from time to time, until showing the right quality, for which according to quality and moisture of the wood from 12 to 17 hours are required. After

finishing boiling the gases and vapors contained in the vessel under pressure are blown over to the sulphite tower, to be used again for making new leach. Then the leach is also removed by letting it run off, the boiled wood is washed twice and finally dumped into drain-boxes. For the described operation for 1,000 kilo wood, 900 to 1,250 liters of leach are necessary.

In addition to the above the more detailed description of the boiler, as taken from the American patent, No. 304,092, is given.

The boiler, which is not as stated above, 12 meters, but only about 6 meters long by 2 meters in diameter, is made of tinned iron and provided with a lead lining. The steam is introduced by pipes to the right and left, which in the digester itself are perforated, so that the steam can freely steam into the mass. The boiler turns about its long axis, not in pin-boxes, however, but upon rollers. To this purpose three heavy rings are arranged at the circumference of the digester, each of which rests on two rollers. The turning of the digester is accomplished by a worm, catching into a worm-wheel arranged at the circumference. The fastening of the lead inside is done by laying it loose against the steel plates of the digester, where it is held by straddle-rings. The lead sheets should be as large as possible, and each should form a complete ring. The joints are soldered together and the finished covering is then fastened to the boiler wall by means of the rings mentioned. These rings are split open and can be driven apart by wedges, whereby the lead is pressed close to the walls. There is an interlayer between lead and vessel. To be able to notice leaks in the lead, the jacket of the digester is provided with a great number of holes, which can be closed by cocks. The cocks are open during working. If it now happens that the lead lining is no more tight, the leach will run away at one or more places through the cocks; these cocks are closed meanwhile until the place to be repaired, which is easily to be found by the position of the cocks can be taken in hand.

These digesters have been proven in practice, as have also the lead lining, fastened by means of the straddle-rings to be practical. To spare the lining, the digester need not rotate continuously, but may be put in motion from time to time, or eventually also towards the end for

quicker discharging. The boilers offer the advantage that they prevent the depositing of sulphate of lime and then prevent deterioration of part of the stuff.

The general characteristics of the boiling process according to Pictet and Brilaz have already been stated. There remains to be mentioned only that after boiling there are contained in the leach not only a quantity of different substances, like gum, resin and etherical oils, but also almost all the sulphurous acid, which could be recovered, wherefore in this method it is especially aimed to use the leach over again, by charging it after the boiling operation into a second and also third digester, previously filled with wood, until it has become saturated with other substances. But as the liquid is retained in the wood by the power of capilarity, and cannot directly flow from one digester into another, the process for this reason requires that the wood after discharging be pressed out, to recover the liquid. By evaporation the sulphurous acid is separated from the resins, etc., in solution, to be recovered by absorption.

Regarding this apparently very simple method it must be remarked that the sulphurous acid made liquid at 10 to 15° below zero, evolves a very great pressure, wherefrom ensues the fact that at a temperature of 85°C in the boiler there is already prevailing a pressure of 7 atmospheres, notwithstanding the considerable dilution of the sulphurous acid, because at this temperature only very small quantities of the sulphurous acid are dissolved in the water. As it is very difficult to exactly regulate the low temperatures this simple method offers considerable danger on account of the high pressures produced as soon as the temperature is slightly raised.

Besides must be remarked that in this process part of the sulphurous acid becomes oxidized at higher temperature, thus blackening the wood substances, the more as in the leaches the protecting lime is missing, which in other method, existing as monosulphite of lime, gives off the sulphurous acid and absorbs and neutralizes the sulphuric acid formed.

Flodquist employs a revolving spherical boiler of steel plates, lined inside with lead, which are fastened with screws having large flat heads, plated with lead. Besides the steel plates have a number of small holes, through which the air can escape when pressing against them.

After the boiler is charged and fed with leach of 5°B it is heated by steam, so that the pressure gradually rises to 4.7 atmospheres. This pressure is kept up (while the digester is rotating about 4 times per hour) until samples show that the raw material is transformed into a pulp, which as a rule requires about 8 to 9 hours time. After boiling is finished, the contents are discharged into a cistern of draining stones or perforated wooden walls arranged below the digester, and later on washed and disintegrated. The presence of the acid phosphate of lime (see leach making) is considered to prevent the stuff from becoming reddish in boiling.

A new American patent of Flodquist is described and illustrated under No. 525,540.

While until now sulphite stuff digesters were heated either from inside by direct steam or from outside by means of a steam jacket, whereby the former method caused a disadvantageous and uneven dilution of the leach and the latter on account of the high steam pressure required, made necessary a very strong and expensive jacket, according to the present invention the digester is heated from outside by means of hot air or hot gases, e. g., combustion gases free from smoke of about 300°C. Because air does not need to be under pressure to be heated to the required temperature, the mantel can be made of quite thin sheets. Because the mantel does also not need to be especially tight, it can be composed of single pieces, which can easily be taken off, to lay free the digester.

The boiler A is resting with hollow pins, BB, in boxes C, and is by means of the worm-wheel D and the worm D1 made to rotate. A pipe L serves to test the inner steam pressure. As usual, a manhole, N, is provided. The jacket, to prevent radiation of heat, is hollow and filled with asbestos or mineral wood. The cylindrical body, E, of the jacket is connected with the walls of the digester by the angle-iron C1 and revolves like the right head-wall E1 together with the digester. Whereas the left head-wall, E2, which carries the inlet H for the hot air or the hot gases, does not revolve. With the ring, e, it turns on the hollow shaft, B, and at Y it is supported against the middle revolving part of the jacket. In the right head-wall are arranged in a circle a number of holes, O, leading to a fixed hollow space, N1. The hot air enters at the left through

the pipe H into the space between jacket and digester, surrounds the latter and reaches through the openings, O, in

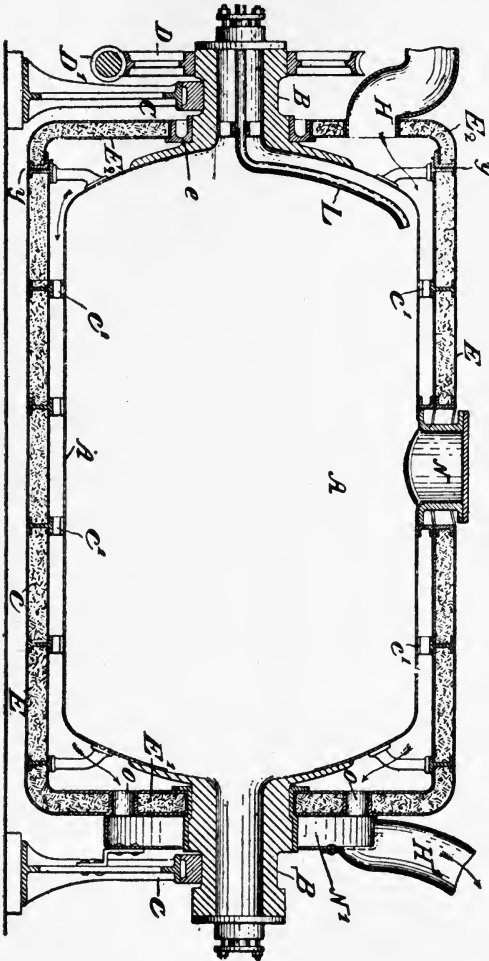

Fig. 56.

the right-hand head wall the hollow space N1, from which it is carried off by pipe H1.

In concluding this chapter a few propositions are yet to be mentioned in regard to construction and lining of sulphite digesters.

A Mr. Wagg in America, like Mitscherlich, lines the digester with thin sheets of lead, lays upon this asbestos paper and upon this 8 inches thick of bricks of one foot square. Every brick is then severed to the digester wall by a bolt in such manner that the head is let into the brick and the nut is put on outside. The bricks have furrows all around, which by means of blunt tools are filled with lead, swallow-tail-like and made tight with it. The heads of the bolts are also covered with lead and the bolts themselves are flattened on one side, so that the acid alongside of them through a cut-out in the nut can go outside, when the lining is leaking. It is thus, as in Frank's digester, made possible to find out where a leak occurred inside and easily repair it.

In the sulphite digesters of Frambach and Dart in Kankauna and Vollrath in Shebaygan, Wisconsin (American patent No. 348,159), where until now the sulphite stuff digesters were provided inside with a lead lining, according to the present invention an acid proof and elastic coating with enamel is employed.

The digester illustrated in fig. 57 consists of single tubular sections provided with flanges and the head and bottom piece B; the different parts are with their flanges connected by screw-bolts. For the purpose of tightening rings of lead, D, are laid between the flanges. All parts mentioned are covered with enamel on the inside up to part of the flanges. The digester is heated by a bent steam pipe, E, which is provided outside with a coat of enamel. For the air-tight connection of it to the bottom-plate, B, the lead-rings, I, are provided.

To coat the different parts of the digester with enamel they are first treated with acid, then scrubbed with sand, rinsed off, dipped into hot lime water and dried. The parts are then wiped off with a sponge and the first coat of enamel is put on. After this has dried, the pieces are heated in a muffle until the melting of the enamel. After cooling off, the second coat is put on and also dried and melted. In enameling, any vitreous enamel which is acid-proof and elastic can be used. A suitable mixture for the first coat consists of 5 parts of lime, 10 parts of feldspar,

5 parts of carbonate of soda, 50 parts of white sand, 50 parts of lead oxide and 20 parts of boracic acid, which are mixed and fluxed together, then ground and stirred with water to a thin mass. For the second coat the above mentioned substances can be employed, adding 10 parts of bone-ash, 5 parts of talcum and 4 parts of cryolite, which are mixed and fluxed together with great heat to a liquid glass, poured into water (for granulations) ground very fine and stirred up in water.

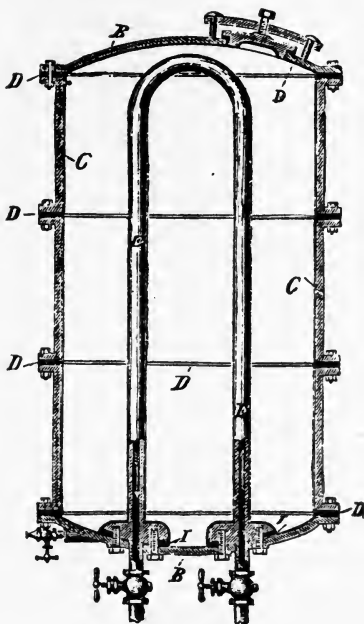

Fig. 57.

Lining for the sulphite digester of Goldburg Harden-Poud in Rutland, Vt., (American patent 351,067) in place of the lead lining used hitherto according to the present invention, for boilers and other apparatuses, coming in contact with acid, a bronze is used composed of 100 parts of copper, $33\frac{1}{2}$ parts of lead, 10 parts of tin and 4 parts of antimony. This bronze is claimed to be very durable and entirely resistant against the acids employed in producing cellulose.

A greater novelty than the methods hitherto mentioned is the employment of an acid-proof protecting mass, which is offered by Wilhelm Wenzel, Vienna, and which is claimed to have proved practical. According to this method the protecting mass is put on in liquid form with a pattern of boards, and according to size and form of the digester, about 60 to 100 millimeters thick. In Mitscherlich boilers of 4 meters diameter the thickness amounts to 125 millimeters. At the bottom the coat must be heavier and rounded towards the cylinder. Revolving digesters of $2\frac{1}{2}$ to 3 meters diameter require a coat of 80-100 millimeters, while for those of 2 to $2\frac{1}{2}$ meters diameter, 70 to 80 millimeters thickness are sufficient. The work requires 3 to 4 weeks. When completed the lining of the digester is exposed for several hours under pressure to a temperature of 140 to 150°C. This causes cracks, which are cut open and again covered with the mass. This is repeated, until no more bad places show up and for finish a coat of 4 to 5 millimeters thickness of very fine mass is applied. According to experience this last coating is used up in 2 to 3 months, but can be easily replaced with a brush in one hour by two men, and after two more hours the digester can be used again for boiling. The 4 to 5 millimeters of used-up coating certainly goes into the stuff, but does not do any harm, it is claimed. As the principal advantage is pointed out, that the boiler always remains tight and the sulphurous acid can never get near the boiler shell. The coat of this method amount to 70 marks per square-meter surface to be lined, where to have yet to be added freight, wages, etc. This method is therefore not cheap, but if given absolute protection, it would be a welcome substitute for most of the methods hitherto employed.

Later on Mr. Wenzel has made several changes in the manner of lining digesters. He does not employ leaden braces, but such of phosphor-bronze, because such do closely bind with the mass. The safety screws of the lead-lined boilers are done away with and are substituted by just as many small open control holes, which permit the lining to be seen from outside. The application of the mass is done slowly and layer by layer, and strong iron wire is laid in crosswise, so that these, similar to the Monier method in building, form an iron skeleton, giving to the whole mass much strength in holding together. The whole layer

is finally about 10 centimeters thick, and lastly porcelaine tiles are laid in, then slowly heated and the furrows occurring are always coated again with cement, until the lining does not change any longer. Later occurring tears and faults are repaired in the same manner. The composition of the mass is secret, but it may be said that cement and water-glass form important constituents of it. A special value of the described lining is in the saving of fuel. The quantitative determinations of the heat used shows that the lining forms an excellent protector of heat; the radiating heat is thus reduced to a minimum. The determinations resulted a saving of 25% of heat as against a digester lined with lead.

A revolution in the making of digester linings seems to be caused by the invention of Herr Director Brungger in Cunnersdorf, as thereby a rapid, entirely safe and very cheap method is given, which has already proved to be practical in many years use in several factories. The essence of the patented invention consists in producing a thin, impenetrable crust at the inner digester wall by introducing a sulphite leach, a sulphate of lime solution into the boiler, previously heated from outside and charged with wood. This crust prevents every contact of the metal boiler wall with the sulphurous acid and used in boiling and thus protects the digester against the destructive influence of the sulphurous acid.

With the protecting means used until now, the lead lining and the many methods of lining with bricks could be provided only at the expense of time and money, the formation of the protecting crust costs neither time nor money. When the protecting crust is once formed it never requires repairing and even a renovation of it seldom becomes necessary.

In employing linings of lead and bricks of any kind the digesters are withdrawn from use during making and repairing of the protecting lining.

In the digesters at Cunnersdorf, near Hirschberg, for instance, while they had the lead lining, about 210 operations were made per year (the balance of the year was used in repairing the lead lining,) against almost 300 operations, after they were provided with the protecting crust. In the figures the renovation of the lead lining is not taken into consideration. The producing capacity of a di-

gester with protecting crust is according to this almost one-half larger than if provided with a lead lining.

The inventors mark another advantage, the cessation of the damaging to the boiler, connected with the leaking of the linings of lead or bricks, as well as the rapid using up caused by this, and the possibility of an explosion. The crust is entirely impenetrable, adheres firmly to the digester, but can be taken off in a few hours and just as quickly renewed. The inventors have after about one year's work of the boiler removed the crust and at the inspection of the inner digester wall by the officials of the society for boiler revision it was found that no corrosions whatever could be discovered in the digester walls. After working four months longer it has been settled by other eminent experts in the same way, that the iron mantel was without fault and the iron appeared as if it had come directly from the rolling mill. The digester provided with the protecting crust therefore offers greater security in working, which is increased by the fact that it works with very little over pressure. The digesters also work with much less consumption of steam, because in consequence of the intermittent work they never get cold.

Against other linings the crust produced by sulphite leach offers the advantage that during boiling it completes and renews itself, if cracks or holes should occur, that consequently it always remains fresh and complete. The heating from outside by steam jacket also permits easy regulation of temperatures and prevents increasing dilution of the leach, produced by the introduction of direct steam.

To the above mentioned experts also belongs Professor Reuleaux, who settled that with the protecting crust as a rule 2 to 3 millimeters thickness is really a protection for the digester itself, because his testimony says that the iron surface, becoming free under the layer, has proved to be entirely free from rust and pores. Nowhere in the whole inside wall not a spot eaten by the acid could be discovered.

In America the method has already been introduced. Not only rotating digesters, but every horizontal or upright digester as well may be provided with the protecting crust, if but a heating jacket around the digester is provided, as the crust inside can only be produced by heating from out-

side. The stuff produced in such digesters is claimed to be better and stronger, because the sulphite leach in them retains its original strength and is not diluted by condensed steam. This has value only in regard to boilers, in which formerly boiling had been done by direct steam.

For Brungger's method not only solution of bisulphite of lime, as prepared in the production of cellstuff from wood according to the sulphite process, are suitable, but also solutions of sulphate of lime, sulphite of lime, sulphite of strontium and diverse others. When using a solution of bisulphite of lime, sulphite of lime is next separated from the hot digester wall, which by further action of the heat is decomposed into sulphate of lime and sulphite of lime, under liberation of water, sulphurous acid and sulphur. When a solution of sulphate of lime is used, it is advisable, to prepare it by neutralization of a weak sulphuric acid solution with carbonate of lime. The degree of concentration of the solution is of no consequence for the success of the method, neither does it matter whether the digester wall is heated before or after charging the solution. When producing cellstuff according to the sulphite-process it is advisable, when working with dilute solutions, to charge it together with the wood into the cold digester and then to heat it. With concentrated solutions this can not be done, as the solution will attack the digester wall too much, before the protecting crust has formed. In this case the empty digester is first heated from outside, the solution then let in and the digester set in rotation, until the crust has sufficient thickness. The wood is charged thereafter. If a revolving digester is used it does not need to be entirely filled; a fixed digester, however, must be completely filled with the solution and besides, next to the digester a vessel should be placed, into which part of the solution can flow over, when the solution expands in consequence of the heating. The heating of the digester can either be done by means of a steam jacket or the boiler may be placed in a chamber of brick, through which are conducted the gases from a fire.

A method for producing a lining for cell-stuff digesters was patented by Guido Baerwaldt in Germany under No. 70,477. This digester on its inside is freed of oxide and other impurities by boiling with acid and scrubbing and then coated with a layer of cement, diluted with water,

potash or soda lye, waterglass, or lime milk, to the thickness of some centimeters. The cement used may be either entirely pure, or mixed with clean quartz sand, powdered glass, ground charlotte or similar substance. Before the ground layer of cement has settled, it is well ground up with a pasty mixture of oxide of lead and glycerine, this last layer being permitted to cover the cement layer to a certain thickness.

The lining thus prepared hardens after standing for a while and forms a vitreous, very hard and resisting crust, which prevents the penetration of the sulphite solution and thus makes the digester very capable of resisting and very durable.

The mixture of lead-oxide and glycerine can also be applied directly to the clean metallic digester wall, but the application is then some more difficult than upon a previous ground layer of cement. The mixture described can also be employed as binder or as mortar when lining the inner boiler wall with acid proof bricks or tiles.

According to the letters of the American patent No. 514,197 of E. Meurer of Palmer Falls, N. Y., the metal of the sulphite digester can be completely protected against the action of the leach by a coating of red oxide and glycerine. The inventor recommends 100 parts of thoroughly dry oxide of lead ground up with 12 parts of pure glycerine and that the coat be made about one-third centimeters thick. The mass must be used up quickly, because it soon hardens into a stone-hard and well-adhering cement. By adding more glycerine the mass becomes more plastic, but dries slower. When desired to further protect the coat by a lining of bricks inside of the digester, the same mixture can be used as mortar and it becomes almost as hard as the stones themselves.

The same inventor describes in a second patent a method of lining the digesters with lead. The sheets of lead are laid against the inner wall of the digester and the edges are soldered together, so that the whole lining forms a single piece, closely adhering to the boiler wall. Because the lead lining is not connected with the digester wall by rivets or cement it will not be influenced by the expansions and contractions of the boiler wall with changing temperatures. But it must be protected by an inside wall

of fireproof stones against falling in when discharging the digester.

While lining with lead the digester is practically brought into a horizontal position. The sheets of lead, when laid against the wall are held fast by a frame with arms and pins.

After all sheets of lead are put in and by soldering together the edges are united into a whole, the digester is placed vertical and the brick lining is then built up. As the wall rises, the pins and supports are gradually removed and finally also the middle beam of the frame.

Another invention, to make the digesters acid-resisting, is by Henry W. Stebbins in West Carrollton, Ohio (American patent 528,339), is as follows.

The overlapping sheets of the boiler wall, to procure a smooth inside face, are provided with a layer of Portland cement, upon which the lead lining is to lay. The lead lining is fastened by lead-rivets, reaching through holes in the digester shell and in the layer of cement and the inside is soldered together with the lead sheet. Upon the lead lining goes a layer, consisting of a poor conductor of heat, such as Portland cement with asbestos, with an admixture of lamp-black, sulphate of barium, oxide of lead and waterglass, to make the porous layer of cement and asbestos resistant to acid. A suitable proportion is given in the letter of patents. As 10 parts of sulphate of barium, 8 parts of oxide of lead, 2 parts of lamp-black and a solution of waterglass of 12° Re. Then follows, built in with cement, a layer of hard burned porous bricks, formed under hydraulic pressure. The next layer consists of Portland cement and quartz sand, lampblack, sulphate of barium, oxide of lead and waterglass again mixed in. It should have the consistency of mortar and is poured behind the innermost layer of glazed tiles.

In England instead of cement for the tiles a plastic mass made of asbestos and waterglass of 1.5 spec. grav. is used, serving to close up the joints.

N. P. Wedege of Drontheim, had patented in Germany under No. 78,966, a discharging arrangement on fixed cellulose digesters and says the following about it:

Until now in discharging the digester the acid was generally first let out by a special pipe attachment, then the upper cover was opened and the digester filled with cold

water to wash the mass and to cool off the digester when the mass was shoveled out by hand. By this process the digester is exposed to sudden and repeated changes of temperature, which has a damaging effect on material and lining, and besides causes a direct loss in heat and time, when the digester is to be filled again.

Often, also, the digesters were discharged by rinsing with water, but in this the changes of temperature have also had an injurious influence, and then a large supply of water was always necessary. Finally the blowing out of the digester by means of the inner steam pressure was employed; but the inconveniences are perhaps greater in this method than in the former. During emptying a vacuum is charged and the consequence often was that the inner linings were injured. Besides the undissolved knots, etc., were crushed, whereby the stuff was soiled.

The hereafter described method aims to empty the digester by its lower manhole, which by means of a mechanism, specially built for the purpose and by the steam pressure conveniently discharges from the digester stuff and liquid. The mixture is then conducted to the stuff-basin, where it is effectively sprinkled with water, so that the badly-smelling leach is mixed with pure water and runs off through the outlet-pipe. The peculiarity of the discharging arrangement is that the lower manhole can be conveniently opened by an arrangement, provided at the upper manhole.

In fig. 58, a is a plate, lying against the edge of the neck of the lower manhole. During boiling this plate is pressed tightly against the cover, b, partially by the pressure prevailing in the digester, and partially by a screw let through the movable guard b1. The plate, a, is by the rods, a2, also connected with a sieve, c, lying against the inner lining, d. By this means an open space, e, is formed for the steam, which during boiling enters through, f, and usually serves to heat the charge of the boiler. The rods, a2, above the sieve form eyes, by which they are connected by joints, a3, with a larger ring, g. This ring, g, is hung to a rod, h, which is joined to a spindle-screw, h2; the latter goes through the upper manhole. The upper manhole cover, i, is provided with a hole in the middle, over which is a collar or hull, j, upon which rests a large nut, k1, by means of which the spindle, k2, can be moved

up and down. When the digester is working and therefore the screw is not used, this nut is covered by a cap and this again is secured by a smaller nut, k_2 , screwed on the shaft, h_2 . All parts inside of the digester are

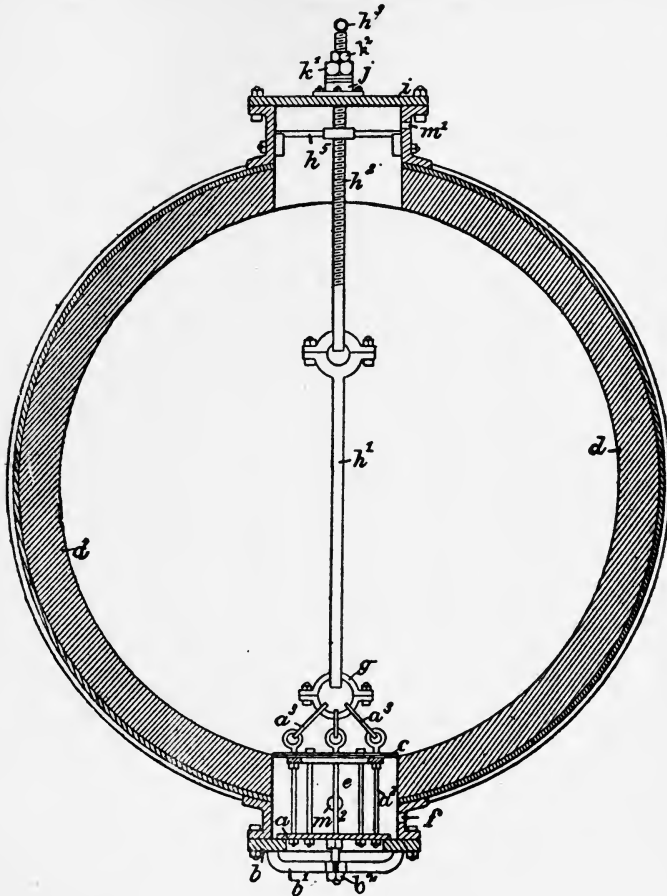

Fig. 58.

covered with lead for protection against the action of the leach or are made of an acid proof material. After boiling is finished the discharging is done in similar

manner: First the gas is blown off, for instance through the opening, m1, of the upper manhole, then the lower guard, b1, is loosened and after removing the nut, b2, is taken off. During this work the plate, a, is held sufficiently tight by the pressure in the digester. In place of the guard, b, a piece of pipe is then set in and fastened by rest screws. This piece of pipe connects the digester with a stuff basin below. Then steam is admitted by means of a perforated pipe, through the opening, m2, above the plate, a, which goes through the digester in several windings, and finally by turning of the nut, k1 (laid free by taking off the cap), the whole lower locking-arrangement is lifted up into the digester. The continuous incoming steam makes the creation of a vacuum impossible, and by causing the whole charge to move, stuff and acid flow through the attached piece of pipe into the stuff-basin.

The whole operation goes on conveniently and safely, and the great advantage is gained of keeping the digester warm, and retaining all gas for the next operation. At the same time the stuff runs out quickly and evenly, without getting soiled. When all stuff is removed from the digester, the steam is shut off and plate, a, is screwed down again in its place. To fill the digester again with wood the upper manhole must be opened. For this purpose the nut, k1, is altogether screwed off the spindle, h2, and this, by means of a chain, hooked into the upper ring, h3, is, together with the shaft, h1, let down into the vessel, until a wedge pushed for this purpose in the spindle, h2, comes to rest upon the cross piece, h5, arranged at the upper manhole. The manhole cover, i, is then removed and the digester is filled. When this is done, i is put on and the shafts, h1 and h2, are lifted and secured.

In regard to the armatures of the digester, the bushings and valves are at present mostly made of phosphor bronze, which offers the most resistance to the acid leaches. Other resistant material may, however, be employed, as for instance C. Curtis and N. M. Jones in Massachusetts and Maine had an outlet pipe for sulphite digesters patented in America, which is claimed to answer the same purpose. According to their statements an iron outlet pipe, lined with cement and protected at both ends by rings of a metal is not attacked by the acid leach.

Fig. 59 shows the iron pipe, *a*, with the flanges, *a*1 and *a*2. Upon the lower flange is screwed a ring, *a*3, of lead or phosphor-bronze, protecting inside and forming an inside flange. Into this pipe is pushed one or more pipes, *b*, pressed out of a mixture of Portland cement, quartz and waterglass. When several pipes are used, the joints are cemented when put in. The cement pipe has a somewhat smaller diameter than the inside of the iron pipe, so that between both pipes a ring-like hollow space is left. By

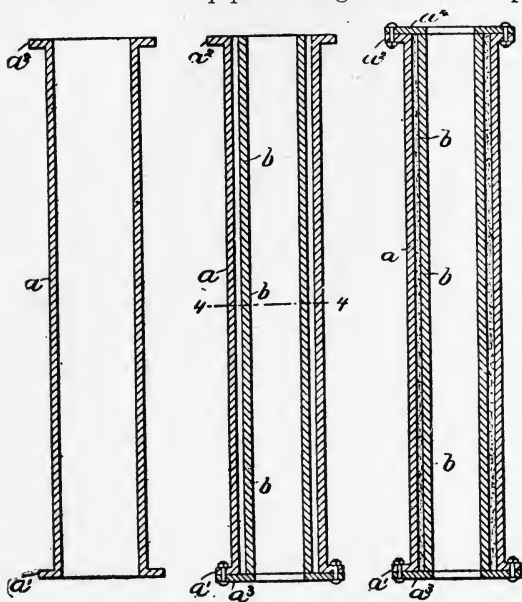

Fig. 59.

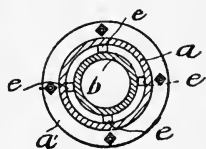

Fig. 60.

strips, *e*, of wood pushed between the cement pipe is given a concentric position to the outer-pipe, as shown in fig. 60, representing a section through the line 4-4 of fig. 59. After the cement pipe is built up to the top the hollow space between both pipes is filled out with cement, at the same time the strips of wood are drawn out and the upper end is protected by an acid proof ring, *a*4 (fig. 59).

In conclusion it may be mentioned that the just described digesters of the different methods are no longer an

indication of the cellulose produced by a factory, because the instructions of the different inventors have been modified to suit local conditions by the manufacture, or changed for other reasons. So for instance was the digester in the Ritter-Kellner factories originally taken for but 30 cubic meters capacity. Now in several such factories digesters of 40 and 60 meters capacity can be seen; indeed the author has seen in one of them horizontal boilers of even 100 cubic meters capacity, externally not at all differing from the Mitscherlich digesters, but provided inside with other linings and having direct steam heating. The Mitscherlich factories have also adopted the new method of dressing the wood, as well as the Frank leach making method, and also employ the new disintegrators.

C. PRODUCTION OF CELLULOSE BY MEANS OF THE ELECTRIC CURRENT.

About this new method nothing more has been published than is contained in the letters of patent, as printed in the *Papier Zeitung*. Whether this method will ever cause a practical revolution in the manufacture of cellulose, can not yet be judged. For the sake of completeness, this new result of the industriousness of Herr Karl Kellner may be described as follows: This method is based on the application of the electric current for the production and continuous regeneration of substances during boiling, decomposing and the incrusting substance of the wood. The wood is heated, while the electric current is passing through at the same time, with such liquids or solutions as under the influence of the latter, furnish those means, which act decomposingly on the incrusting substances.

For this the solution of the chlorides of metals are suited and especially that of sodium chloride. as the incrusting substances of wood, straw, espartos, etc., are decomposed by chlorine, as well as by certain of its oxygen-combinations, such as subchloric acid (hydrogen hypochlorite).

When the vegetable matter to be decomposed in desintegrated condition are heated in closed vessels with solutions of sodium chloride and at the same time an electric current is passed through the solution, chlorine and subchloric acid are produced at the one side and hydrate of soda at the other, the elements, chlorine and sodium, lib-

erated at the poles (electrodes), forming with water subchloric acid and hydrate of soda.

In decomposing the incrusting substances by chlorine and subchloric acid, as well as when heating subchloric acid by itself, hydrochloric (muriatic) acid is formed, which in contact with sodiumhydrate reproduces sodium chloride so that a circulation takes place, and the same liquid runs through the whole process unweakened.

The process goes on smoothly at 128°C and according to the statement of the inventor at that temperature a snow-white, unweakened fibre of silky gloss is obtained from wood.

In working this method an arrangement is used consisting of three vertical digesters, connected on top and below, lying in one plane. Both electrodes enter the outer pipes below and into side pipe, in which both electronegative ions (chlorine and subchloric acid) are rising during heating, is filled the vegetable material. The liquids containing the ions and its products of decomposition rising during heating, and meet above, thereafter descending through the middle pipe. When passing the electrodes decomposition of the chlorides takes place again. Very good results can be obtained in this arrangement by changing the current, whereby the second side branch is filled with wood, etc. The vegetable matter is then alternately submitted to the treatment with alkaline and acid solutions. The soda lye formed thereby acts decomposingly on the incrusting substance in such manner that they are quickly dissolved when the current changes. To produce, for instance, white cellulose for the manufacture of paper from pine wood, the wood disintegrated by the usual wood choppers is charged in to the digester and the latter closed, whereupon chloride of sodium solution is let in. In general on 8% solution suffices and about $3\frac{1}{2}$ hours at a temperature of about 126°C is required (counting from the point of the temperature reached) to produce from pinewood, white, firm cellulose which can be used for finer papers.

The boiling itself is done in vessels, the inside of which is lined with lead or other resisting substances. The following well proven arrangement (fig. 61) consists of both fixed digesters A and B, which are connected below by the pipes I, above by the pipes H, and provided with

charging opening E and below with discharging openings. Perforated plates at the upper and lower ends prevent the fibres from being carried along by the current and clogging the pipes. The two pipes H make connection with a smaller intermediate vessel L, which carries gauge-glass, macrometer, safety-and discharging valve and a pipe T, which can be shut off by valve V, the prolongation of which forms a coil, lying in a cooling tank P. The vessel L ends in pipe K, which leads below the bottoms of the digester and then runs out into fork-like branchings I, which turning up at both sides, run into the bottoms of the digesters. Into these pipes at M and N the two carbon electrodes, R and S, are introduced insulated. After the digesters are filled with wood and a solution of chloride of sodium is let in until it becomes visible in the gauge-glass of the vessel L, valve V and all openings are closed, into the heating pipes running through the digesters, and steam, as dry as possible, is admitted.

Because the contents of A and B are expanded by the heat, they rise through H into L, thus causing a descending current through pipe K. When leaving K the liquid divides and rises again in the direction of the arrow through pipe I, to enter again into the digesters A and B, and to repeat this circulation. In passing of the liquid at the electrodes, when the current is closed the decomposition commences and the before mentioned side-processes take place. When at M the positive, at N the negative current is entering, the incrusting substance of the wood contained in B is submitted to energetic oxidation on account of the action of the chlorine or its derivatives, while in A the resins existing in the wood, contained in there, are saponified. The products of decomposition (as far as they are soluble) meet in the vessel L and act upon each other in such manner that as end-product chloride of sodium is formed again, the hydrochloric acid formed at the anode decomposing the organic compounds coming from the cathods and separating the organic matter, regenerates the original solution of chloride of lime, while the separated organic matter by the continuously renewed influence of the chlorine and its combinations is decomposed into products, which either remain in solution or escape in the form of gas.

After the process has been conducted in the manner de-

scribed for about one-quarter to one-half hour, the current is changed. Thereby by the alternating influence of chlorine and soda upon the wood its dissolution is quickened. Therefore, the changing of the current is repeated often, until the fibre is laid bare, which at a temperature of the leach of about 126°C is affected after 3 to $3\frac{1}{2}$ hours. The inactive gases evolved during the operation, which accumulate in the intermediate vessel L are by the occa-

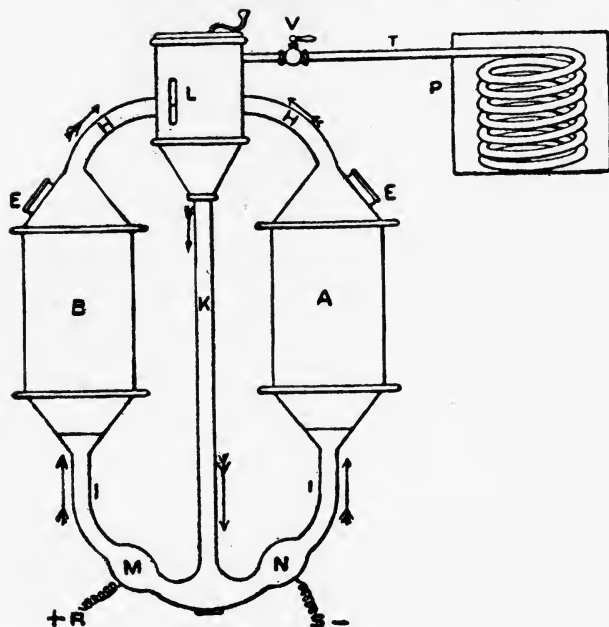

Fig. 61.

sional opening of the valves V driven into the cooling and condensing apparatus.

When the work is carried on in the manner described above, snow-white cellulose is obtained from the vessel, which at the end of the process had the unode under it, and this can be used for the finest sorts of paper without bleaching, while the product from the cathode vessel is colored somewhat yellowish by the alkali formed at the end of the process, and after washing needs to be treated with a very weak solution of chloride of lime.

Repeated experiments have proved that it is of greater advantage not to treat the wood any more in metal vessels, but in open cisterns of masonry, consequently to work without pressure. The cisterns consist of cement mason work and are lined with burned clay tiles. The cut wood is soaked with a salt solution before filling it in the cistern. The electric current produced by dynamo machines and conducted through the mass evolves from the salt chlorine and sodium, which accumulate at the poles and act partially dissolving, partially bleaching. By pressing a button the current is from time to time reversed, so that the sodium goes to the pole, where previously chlorine had accumulated, and the chlorine to the pole, where before soda had appeared. By this changing treatment with soda and chlorine the wood suffers complete dissolution and bleaching, and the chloride of sodium is continuously regenerated.

At a most convenient site in Hallein, near Salzburg, reputed for its strong brines, Herr Kellner has already made a plant on a large scale, according to his latest system.

Now, after four years, a conclusive opinion cannot yet be passed about Dr. Kellner's process to produce cellulose by means of the electric current, at least in a perfect, practical shape. The inventor himself has authorized the writer to make the following statement about the present stand: The electrolytic cellulose manufacturing method, as such, on a smaller scale, works quite well, but until now it could not be introduced into large practice, because the apparatuses of the decomposition cells required so many repairs that the advantage offered by the process were counterbalanced. Dr. Kellner has for this reason left the process entirely for some time, and set himself especially to the improvement of the electrolytic parts of the apparatus; he has succeeded in this to such a degree that he has accomplished the most difficult part of the industrial electrolysis, i. e., the spitting of common salt into its components, practically on a large scale, so that already two large soda and chloride of lime factories in England are almost completely filled up accordingly and also in Austria such an establishment is going to be built. These experiments and labors made in other directions have not directly benefited the electrolytic cellulose manufacturing,



but have removed these difficulties, which until now were in the way of the industrial employment of the electrolytic cellulose process and now soon after finishing the plants designed for this purpose the experiences gained will be of value in the manufacture of the electro-cellulose. The electric process itself, as said before, is excellent, the paper made of such cellulose is very solid and pure. To work the process, however, especially in regard to the choosing of materials was, until the electrochemic soda and chlorida of lime process were worked out, too expensive. The question as to the practical value of the method must therefore be left open for some time.

In connection with this it may be mentioned that Herr Kellner had also patented the electric bleaching method as such and indeed "La Papeteric" in France describes this as follows:

"The process in bleaching vegetable fibre, which is the object of this patent, is based upon the observation that the coloring substances adhering to the fibre are by the alternating application of chlorine and alkalis easier transformed into water-soluble combinations, than by chlorine alone. This occurrence is caused by the chlorine, before transforming the coloring substances into water-soluble combinations, causing the formation of intermediate products, insoluble in water, but soluble in alkalis. When, therefore, after the intermediate products are transformed into an alkaline solution, the chlorine is acting again, not only chlorine must be saved, but the bleaching must also be affected in less time.

The saving of chlorine and time will be the more as in the ordinary chlorine bleach hydrochloric acid (muriatic acid) is formed, and therefore the action of the chlorine must be kept up, until acid-soluble combinations take the place of the water-soluble combinations.

According to the present invention an alkali-chlorine-combination is decomposed by electrolysis. Thereby the electronegative and the electro-positive products of decomposition (Anion and Kathion) are alternately conducted through two separate quantities of the bleaching liquid, then united and again taken to the electrolytic apparatus.

The arrangement may, as in fig. 62 and 63, have the form of a double bleaching hollander, or, as in fig. 64, that of a tub or of two separate bleaching hollanders.

The hollander represented by fig. 62 in plane and by fig. 63 in section is by a wall *aa* through the length divided in three compartments. The fibre stuff to be bleached is by pump *d* carried to the middle space. It flows along the sieve-like perforated bottom and at the end of it gets under the paddle-wheel *f*, which is in continuous motion. By this it is taken up and driven to the side compartments *cc*. In one of these compartments the electro-positive decomposing solution is through the perforated pipe *g* admitted to the mass to be bleached, while in the other compartment the electro-negative works through a similar pipe *g*. The bleach-stuff flows upon inclined bottoms

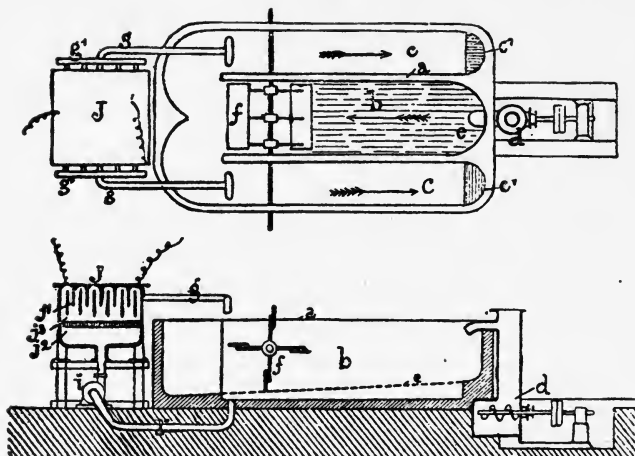

Figs. 62-63.

through the side compartments to their lowest place lying near the original inlet and there runs through the openings *cc* into a reservoir, from where it is again carried to the middle space by the pump.

Meanwhile the two ions have united again, the regenerated decomposing liquid accumulates under the sieve *c*, and by the pump *i*, and it is returned to the electrolytic apparatus *j*, through the pipe *r*. There, before it reaches the electrodes, of platinum, carbon or zinc, it flows through a sieve *j2*.

The jointed anodes and cathodes are at its upper parts

separated by short divisions $j\beta$ and the so formed compartments open below, are alternately connected with the one or the other of the pipes $g1 g1$, which are arranged along both sides of the compartment j . In consequence of this arrangement, the one pipe conducts electro-positive, the other electro-negative decomposing liquid into the connecting pipes gg .

When the electric apparatus is to be connected with two separate bleach hollanders, the bleach mass in both of them is kept in continuous motion by suitably arranged pipes, and wash drums return the decomposing liquid to the apparatus. In this case the direction of the electric current must from time to time be changed so that the

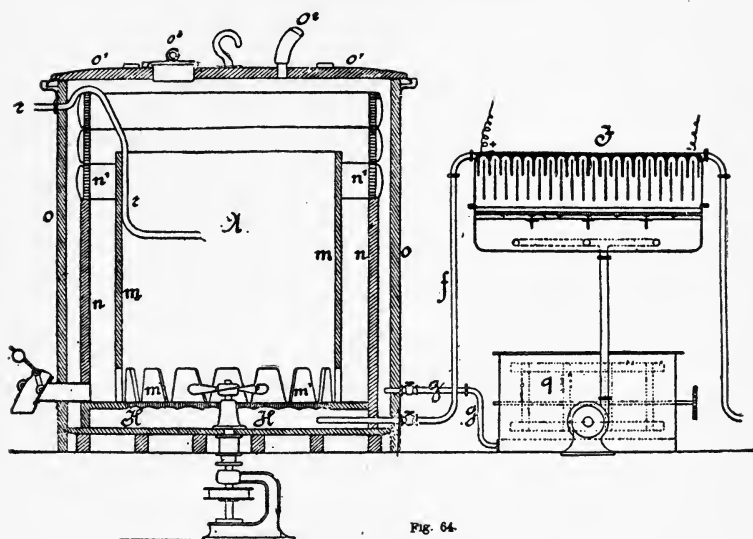

Fig. 64.

fibres to be bleached are alternately submitted to the action of chlorine and alkali.

This changing of the direction of the current is also requisite, when the apparatus is built as in fig. 64. The bleaching process here takes place in two cylindrical tubs with threefold partitions in each. The mass of fibre to be bleached is introduced in the innermost space A of the tub and there kept in continuous ascending motion by means of a propeller screw p , set into the bottom. The

stuff flows over the walls m into the hollow space between m and n and, following the current caused by the screw, enters again into the inner space through the trapezeshaped openings m1 in the bottom.

The circulation of the bleach mass could also take place in reversed direction. It would then be driven out by the openings m, rise up between m and n and return over the edge of m.

The electro-positive decomposing liquid (Anion) enters through the pipe f into the hollow space H. The lower face of this hollow space is solid and tight, the upper is sieve-like, perforated and covered with filter stones, so that the anion filling the space H can come in contact with the bleach stuff.

The electric-negative decomposing liquid (cathion) enters into the like bottom of the other bleach tub. Both liquids flow through the bleach mass from below upwards, enter through the sieve-like upper part of the walls n1 into the space between n and o and from there flow through the pipes g into the reservoir q. By the uniting of both liquids, taking place there the solution, having been submitted to decomposition, is regenerated and again conducted to the electric decomposition apparatus. Both tubs are provided with water and air-tight covers O1, at which openings O3, with blow-off-valves are arranged. These openings permit the taking from time to time of samples and the controlling of the bleaching process. The pipes r serve to admit steam and to heat the mass.

In place of two tubs whole rows of them can be used and connected with each other by pipes, as it done similarly with the diffusion batteries in sugar factories. In such manner continuous work is possible.

About an improvement of his electric bleaching method Dr. Kellner writes in the *Papier Zeitung* set 1894, page 2,486, as follows:

As easy as the decomposition of a solution of common salt into chlorine and sodium by the electric current takes place, and notwithstanding the numberless experiments made it has not become possible until recently to find out a method which has prospects for practical success.

The older methods failed principally on account of too-rapid consumption of the complicated apparatuses and of the insufficient transformation of the required motoric

power into electro-chemical work. Siemens & Halske in Vienna have now come forth with methods different from those of Dr. Karl Kellner, which for simplicity leave nothing to be desired. The following illustrations represent the Kellner method for bleaching of paper stuff.

Fig. 65 shows the so-called bleach-block. It consists of the plates A, A1, A2, at one side covered with platinum, which by the rods, B, B1, B2, are united into one solid body. When such block is set in a hollander and connected with

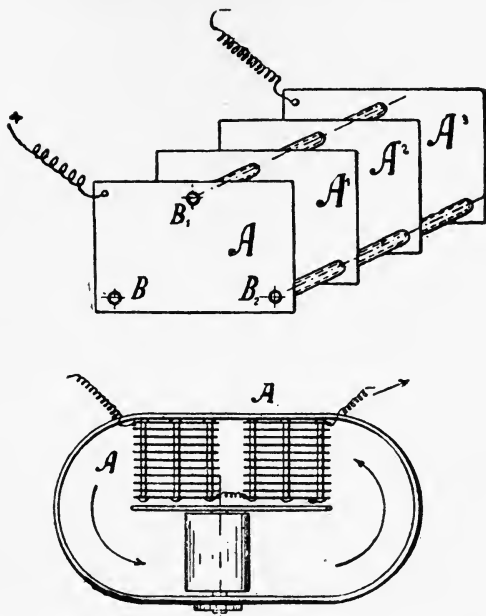

Fig. 65.

the clamps of a dynamo machine, the stuff in the hollander is at once bleaching, after adding solution of salt. The stuff is continuously passing between the plates, A, A1, the electrodes and can therefore be bleached with little power, as the chlorine evolved from the salt is acting in status nascendi, the much more powerful state of creation, as well-known. Fig. 65 shows a hollander with two of the blocks described. The salt solution is continuously used over again, and by adding fresh salt, kept at the original

strength. By the decomposition of 20 kilogrammes of salt, 100 kilogrammes of stuff are claimed to be bleached; what kind of stuff is meant is not stated.

When several bleach-hollanders are placed in one room, the method represented in fig. 66. is recommended, in which for cheapness no platinum is used. Fig. 66 shows the electrolytic apparatus in section and plane, the electrodes consist of carbon; they are claimed to be cheaper and more durable. The salt solution flowing into the apparatus through the pipe, visible to the left above and provided with a valve, must find its way to B, as indicated by the arrows, between the electrodes, arranged alternately, forming a number of cells. As visible in fig. 66, the hypochlorite-solution produced in the apparatus mentioned from the salt solution flows at B through the filter F below, of glass wool into the bleach hollander. If instead of carbon, platinated plates are employed, the filter can be dispensed with. The drain-box K serves to receive the bleached stuff; the off-running salt solution is accumulating in L and after closing the valves h and h3 and opening h1 and h2, is by the pump P used for rapid filling of the hollander when charging fresh material. The valves h1 and h2 are then closed, h and h3 opened and by the pump a steady circulation of the salt solution through the electrolyser filter and hollander is affected during bleaching. A further improvement of the Kellner bleaching method is spoken of in the *Centralblatt für Oesterr. Ungar. Papierindustrie*, from which is taken the following:

In the decomposition of common salt by the electric current, without using a diaphragm, the products of decomposition, chlorine and caustic soda, unite in to subchlorite of soda, which forms the effective constituent of the bleaching liquid. Besides this principal process several side-reactions take place which lessen the practical effect and mainly consist in the formation of chlorate and the reduction of already formed sub-chlorite of soda to chloride of sodium. These side-reactions formed one of the principal difficulties in working out the electric bleach method. Then also contact difficulties and disagreeable experiences with the different electrodes came up. Carbon electrodes are certainly cheap, but are quickly consumed and require filtration of the bleach liquid. Whereas platinum electrodes, if anyway durable, are very expensive and on ac-

count of the high amortisation add much to the manufacturing expenses.

By introduction of his pointed electrodes Dr. Karl Kellner believes he has found a practical solution of the question. These electrodes are plates of hard rubber, or other resistant material, which in the form of a brush are provided with platinum points and in a box of ebonite are connected for tension. With this arrangement, it is claimed, to produce under very favorable circumstances solutions with to 1% active chlorine, which concentration is

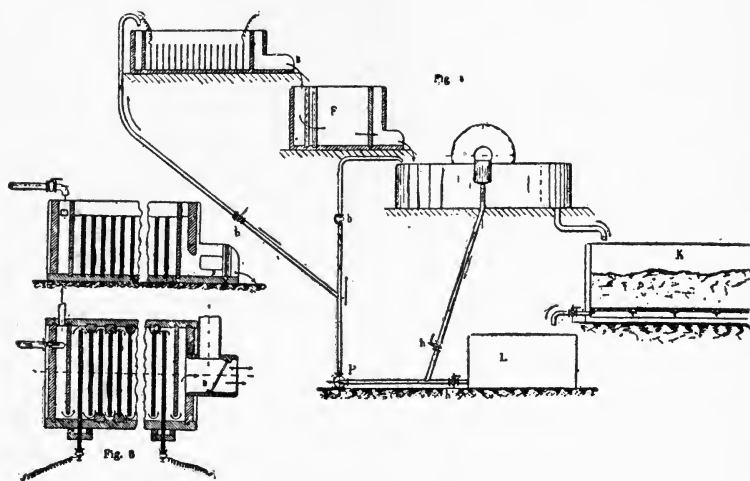

Fig. 66.

for most requirements perfectly sufficient. The composition of the produced 1% bleach liquid is with equal conditions of current mainly depending on the concentration of the salt solution employed and on the temperature observed in the electrolysis.

The bleach liquid, of 1% active chlorine, produced under normal conditions from 10% salt solution, contains:

2.09% hypochlorite of soda

0.60% chlorate of soda

7.90% undecomposed chloride of soda

The 6% chlorine contained in a 10% salt solution consequently divide as follows:

1.0% Cl as Na Cl O

0.2% Cl as Na Cl O₃

4.7% Cl as Na Cl.

The bleach liquid running off is entirely clear and open and keeps unchanged quite long. After standing for days the bleaching strength decreases, as with solutions of chloride of lime; the decreasing is different, according to whether the liquid is kept in the dark or in the light.

V. WASHING, BLEACHING, FINISHING OF THE CELLULOSE.

These finishing manipulations, although different in character, are not connected with the kind of methods heretofore treated, and may therefore be treated now, without regard to them. When the knots were not bored out, or sorted out before boiling the wood then after the discharging of the digesters, sorting by boys and girls must be done, especially when the wood had been cut into slices. In this case the workmen throw the cellulose on a table, divide the soft mass with the fingers and in this manner easily find the knots and hard pieces of wood, which have, perhaps, been only partially boiled. When yellowish and harder cellulose adhere to the knots, they are laid aside and worked up later on, to obtain an inferior cellulose, so-called third quality. As, however, in spite of all sorting the knots do not absolutely disappear and a forcible dividing would disintegrate the fibres adjacent to the knots, by which the quality of the cellulose would be lessened, it is necessary to take care that this separating of the fibres is done as carefully as possible. Mitscherlich has employed for this purpose a stamping mill, which however does not properly crush the stuff, but rather grinds it, as shown in the following description.

Fig. 67 represents a sideview and section of such stamping mill. In about seven iron frames A rests the thumb-shaft B, rotating about ten times per minute. The frames are connected by two pairs of heavy timber, C1 C2, and D1 D2, which at the same time serve as guides for about 60 stampers, one next to the other, which again reach to near the bottom of the stamping-trough E, sketched in section, which is about 15 meters long, and inclining about 0.6 meter, counting from the head to the end. The lifting thumbs are set around the shaft in such manner that three

or four neighboring stampers are not lifted at the same time with every revolution, but one after the other; so that they work as shown in fig. 68, representing part of the front view. In this manner, the first stamper, at the head of of

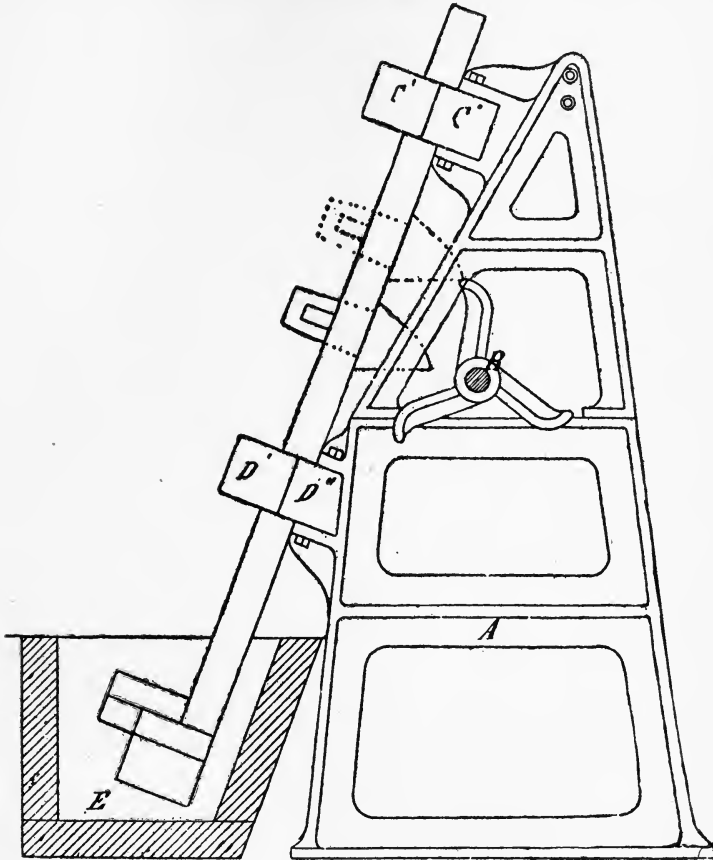

Fig. 67.

the trough, when going down, carries part of the stuff to the second, this one to the third, and so on; until finally, while water is continuously running in, the stuff reaches the other end of the trough in the form of a thin pulp. As the stampers do not quite reach the bottom and carry

below a wider shoe, but do not touch at the sides when the one stamper falls and the next one is lifted, the stuff is slightly triturated in the spaces between without injuring the fibre or crushing the hard pieces and knots. The picked cellulose is poured in the lower end of the stamping trough by the workmen, or, when the sorting takes place in an upper loft, in a large, wooden funnel, by which the stuff is continuously fed to the trough. A workman then has to regulate this feeding, also the water supply and at times he must assist the stuff to move along the trough. By more or less closing the outlet opening of the trough, the stuff is retained in the trough for a longer time and more or less worked through, as made necessary by the quality obtained in the boiling operation. A second necessary labor is the washing of the stuff, that every trace of leach, especially of sulphurous acid is removed from the cellulose. This, according to Mitscherlich, is not done in a violent manner, but by a system of so-called wash troughs, by which though much water is used the fibering and washing is done very effectively, and at the same time an assorting is effected, so that at the end only the finest fibres flow off, while all heavier particles settle before. As it is essential, to make the trough as long as possible, in order to save space two such troughs are generally arranged one above the other. They are given the form shown in fig. 69.

A wooden trough about 1 meter wide and 300 millimeters deep is provided at the bottom with so-called sacks or knot-catchers, in which all knots, hard wood particles and coarse splinters, kept back, settle; which later on, when cleansing of the troughs becomes necessary, are let off by holes provided with bungs. As soon as the stuff leaves the stamping trough, it is next by one or more powerful sprays of cold water, not only diluted, but the loosely connecting bundles of fibres are at the same time washed apart, so that the much diluted mass consists mainly of separate cellulose fibres, floating side by side. For more effective separation the stuff is often at the head of the trough made to pass one or several stirrers, or a so-called knot beater is used, as employed in paper mills, which have centrifugal hollanders; or the stuff is first let over a plain, large knot catch, formed of wooden slats, provided with a shaking

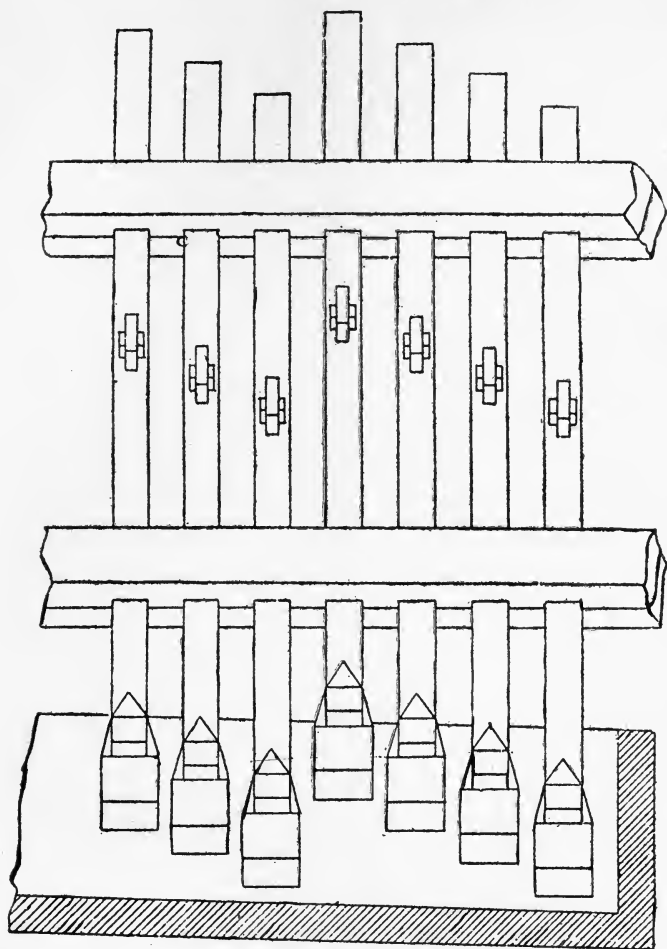

Fig. 68.

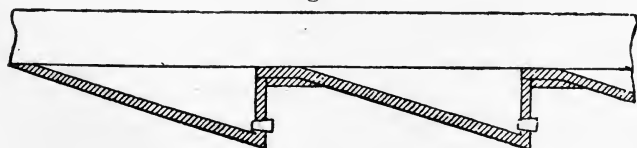

Fig. 69.

arrangement. By these arrangements the lime, gyps and coarser fibres are retained, but the small splinters, which indeed are really but small bundles of fibres, not yet separated, but otherwise soft particles of cellulose, stay in the stuff, and must be removed, as much as possible. This is done by either one or two, or a whole system of plate-knot-catchers. The whole stuff must go through the narrow slits of the knot-catcher plates, which is affected by beating with an up and down motion, which causes the stuff to be sucked through. A convenient arrangement of this kind is shown in figs. 70 and 71.

By an elevator or by a worm the stuff is lifted from the stamping trough and enters the wash-trough at A. It flows, much diluted with water, through the different sections, as indicated by the arrows, and finally enters a small trough B, from which it runs on the four plate-knot-catchers, arranged side by side, under it in the trough C and from there it is carried to the fillers.

Lately, however, the Wandel cellulose cleaners are used. They are quite similar to the rotating knot-catchers previously built by the same firm. The only practical alteration is that they are not moved up and down by paddle wheels, but are rotated very quickly and thus suck inside the thin stuff, by which they are almost totally surrounded, and consequently they work perfectly noiselessly.

Lately Wandel has constructed another sorting arrangement for cell-stuff and patented it in America under No. 478,170. In the *Papier Zeitung* the description reads as follows: The stuff to be sorted flows through a trough a as into a tank a1, in which is set a quickly rotating sorting cylinder b, as its circumference provided with fine slits. The fine stuff enters through the slits into the cylinder and runs off through the central openings at both ends. Inside the cylinder are fastened the paddles d, forming with the circumference an angle of about 45° and with the rotating of the cylinder in the direction of the arrow act with suction on the stuff, and accelerate its passing. The coarse stuff settles on the round bottom of the trough and is removed through the channel h at the side, the cover of which, i, is for this purpose opened without interrupting the work. For totally discharging and cleaning the trough a, the opening k is provided.

A centrifugal cell-stuff sorter is built by Wagner & Co. and described in the Papier Zeitung as follows:

The cell-stuff, mixed with much water, is conducted

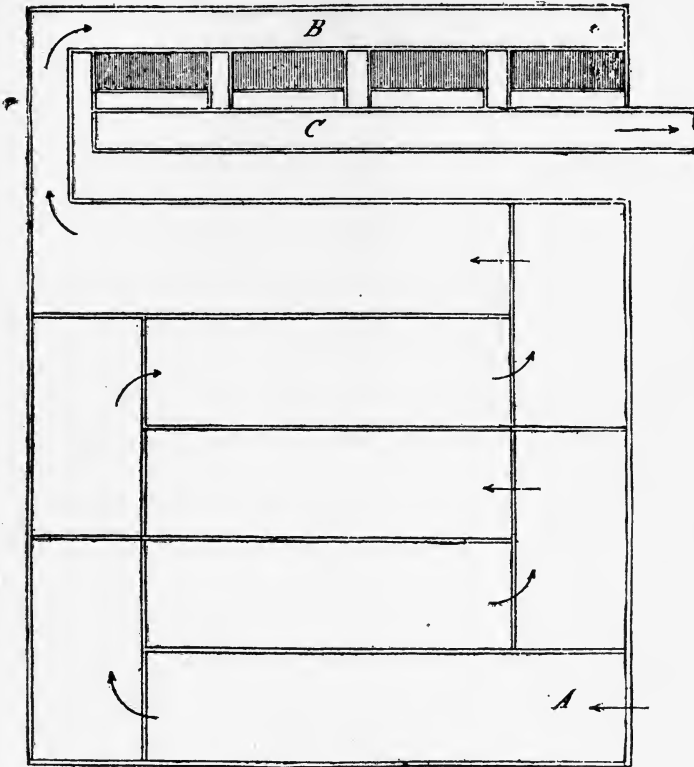

Fig. 70.

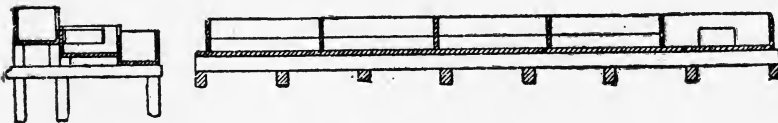
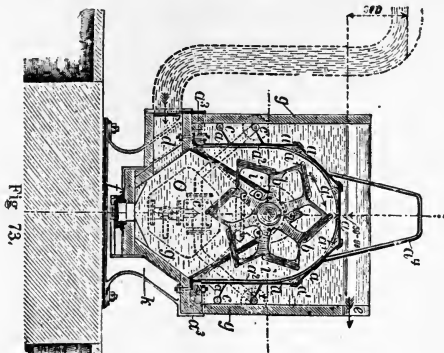

Fig. 71.

through the pipe *d* to the lower narrow part of the trough *c*, filling this up to the overrun *e*, from where it flows over a wide trough, not shown here. To get there, the

stuff must pass the sieve-cap, consisting of the knot-catcher-plates a. These 3 mm. strong brass plates are provided with straight slits of 4-10, 5-10 or 6-10 mm width. The frame, in which the plates are set, consists of the foot piece a3 (fig. 73) of hardwood, into which are let the vertical plates, also the joints a1 and the stiffening bows of iron, copper or bronze of 60 mm. width and 12 to 15 mm. height, which connect all cross-pieces, and serve as impost for the one meter long plates. There will consequently be one such bow for each meter length. At the two end-bows are fastened the bows a4, by which the whole sieve-cap can be lifted out, after loosening the set screws, by which the foot-pieces a3 are connected to the walls g. To take them out is necessary as often as the plates have to be thoroughly cleaned, and can be made more convenient by suspending the cap by rope and pulley. The vertical plates are kept clean during working by the sprinklers c, of which there are two on each side and which are regulated by a cock on each end. To make the sieve cap tight at both heads, the two headwalls i are cut out in triangular shape and set on similarly formed inside walls h of the tank, as shown by the dotted lines in fig. 73. Where the edges join, they are lined with strips of felt and the weight of the sieve cap by itself secures tightness. A beater b1 which makes 100 to 120 revolutions per minute, with its wooden scoops, going through and resting on four crosses, drives the stuff through the plates. The stuffing boxes b, of the beater shaft are not fastened to the wooden tank, but rest on the iron support k, being thus independent of the changes in the wood. A box support b2 carries the end of the shaft, besides the driving pulley. The heavy impurities settle in the lower part of the tank and can be removed through the slide f. The stuff should run down from a height of 300 mm. above its level at e, where it runs off about 50 to 80 mm. above the upper plate a. The sprinkle pipes c are mainly for the purpose of keeping the stuff in motion and do not need to work all the time. The upper plates have by experience proved to keep clean themselves. It is claimed that it costs little to work the sorter, as the cleaning is going on rapidly and the consumption of power is small. Through a sorter of 2,500 mm. length and 4-10 mm. slits 4,000 kgr. of long fibred Mitscherlich stuff will go in 24 hours.



Figs. 73 and 74.

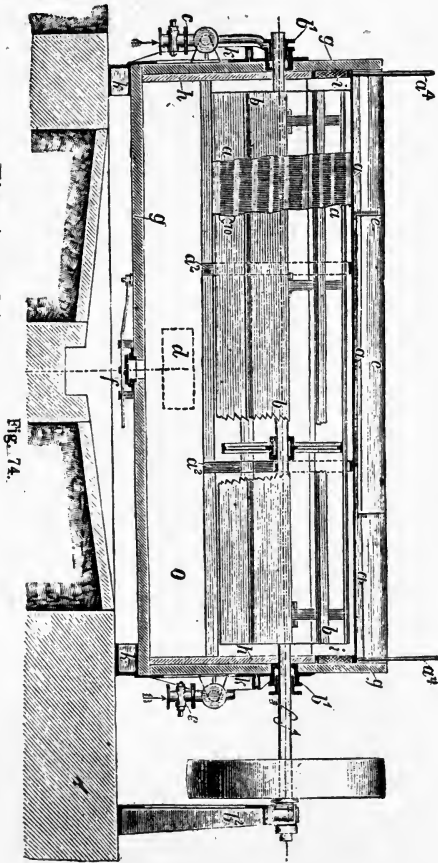

The stuff, freed from splinters as much as possible by one or more cellulose cleaners is then run on a filtering arrangement, like a small paper machine, only the sieve is shorter, made of stronger wire, meshed wider and does not have a shaking motion. After the so-called gonch-

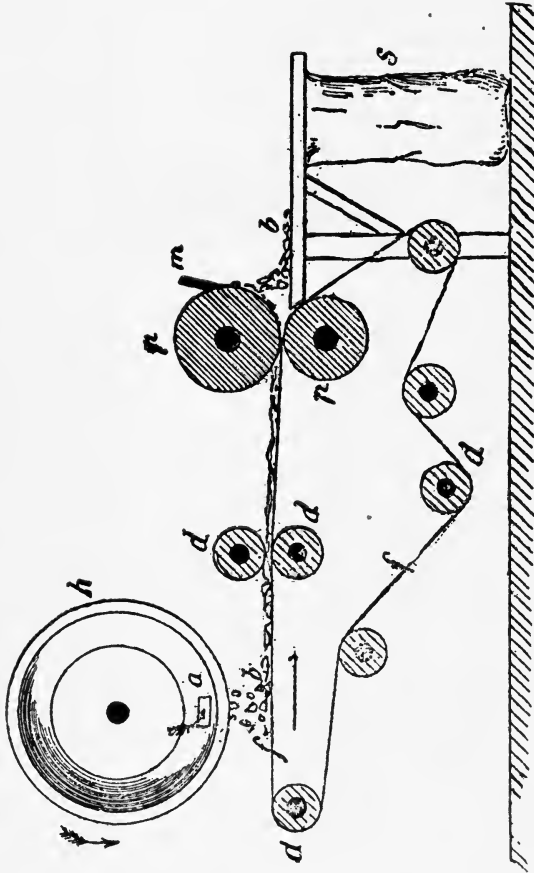
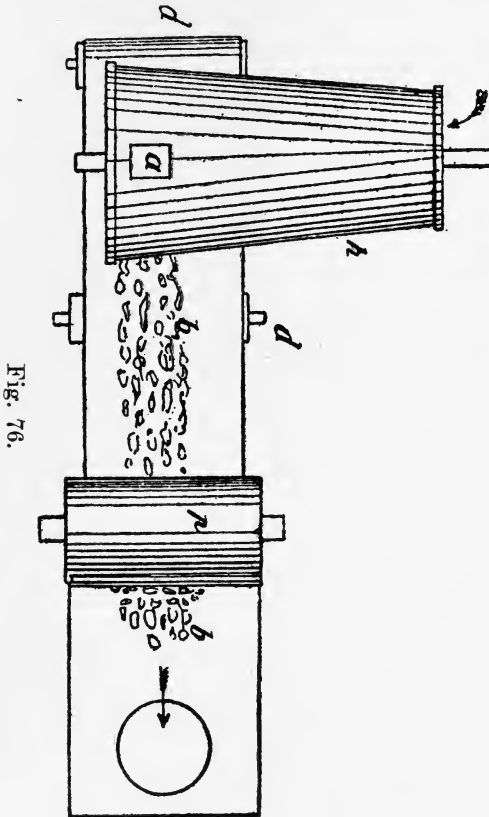

Fig. 75.

press, as a rule the pasteboard like stuff is passed through a second press, screw or lever-press, in order to obtain a product as free from water as possible. The quantity of water in cellulose passed through a second press and then

wound up in rolls as a rule amounts to about 50 p. c., sometimes more.

Mitscherlich has not himself used the above described filtering arrangement, but the so-called hair cylinder, which turns out the cellulose in the form of lumps. The



accompanying illustrations show the same in section and plane: The cylinder *h*, covered with a sieve or horse-hair, is conical.

The stuff enters in the direction of the arrow, the water is thrown out by rapid rotation and the pasty stuff falls through the opening *a* on a felt *f*, which is carried and

stretched by several rollers d, d, d,; passes between the press rollers p p and is carried away in the direction of the arrow. After this water is pressed out from the stuff by the press rollers, the stuff b adhering to the upper roll p is scraped off by the shaver m, falling on a table and by a hole in it is directly filled into a bag, S, to be shipped as so-called lump cellulose.

In late years various apparatuses have come into use for dividing the boiled wood, in place of the stampers, not only in the Mitscherlich factories, but also in other systems, among which the so-called "separator" has gained the widest distribution. This does not at all injure the stuff, and with comparatively small power does good work. It is described as follows:

Fig. 77 and 78 show it in long and cross section. It consists of two wooden drums somewhat conical, about 5 meters long and 1 in diameter, of which a is the upper in which the stuff carried by an elevator enters at e. The drums themselves are fixed, but inside of them are moving strong wooden shafts c d, on which are set along a spiral line a large number of long sticks, which nearly reach the circumference of the drum. The velocity of the upper shaft c is 80-100 revolutions per minute, while the lower makes about 160 revolutions. The thick stuff, which in the upper drum is diluted with but little water by cock w, is then, by the sticks, repeatedly driven against the circumference, until leaving at the other end at f, it falls into the second drum, is there diluted with more water and leaves at g, with fibers entirely clear, and with still more water it reaches a wash trough, as long as possible, in which sand and small knotty particles can settle. At the end of this wide trough one or more wash drums are arranged, which remove the surplus water and from where the pulp runs either directly into the bleaching-hollander or is let into draining boxes.

Another new system for dividing cell stuff is Engelmay-er's system consisting of three patented apparatuses, built by the C. D. Bracker Sons. The following is said about it:

After the wood is well boiled, i. e. dissolved, it is by means of an elevator conducted to the first apparatus of the dividing system, the fiberer, the task of which is to separate the fibres from the boiled knots and the still hard particles of wood. In the mixer, connected to this,

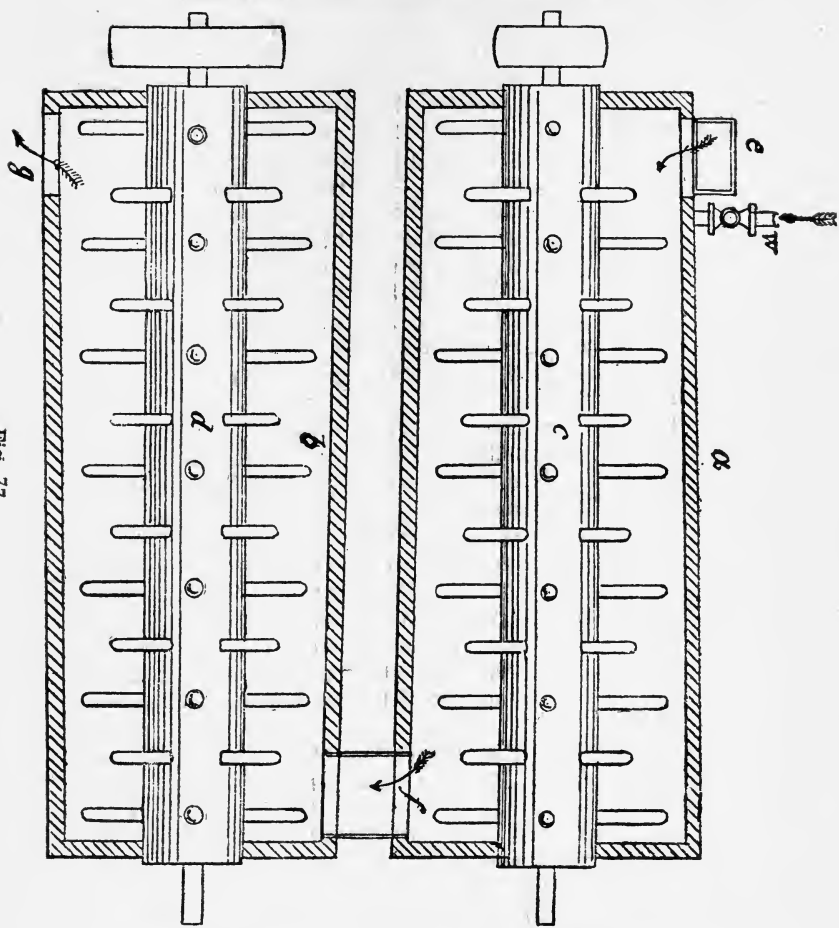

Fig. 77.

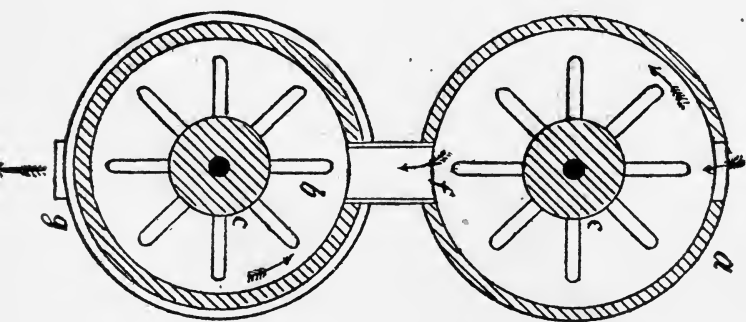

Fig. 78.

the mixing and diluting is done. The knots and particles left hard are separated in the sorting apparatus. From there the stuff is conducted through a convenient sand-pang, in which are retained the still present heavy particles, as well as the resins, beaten off by an apparatus, arranged in it. The succeeding apparatus, the washdrum and filtering machines, serve to partially separate the water, and the stuff then reaches the "squasher" in which the straightening and dividing of the fibre is effected. The conclusion of the dividing system is formed by a "dissolver," from which the stuff is conducted to the beating engine and eventually to the long sieve machine. Knot-and-splinter fangs are not employed.

In the following the different operations and apparatus are exactly described:

1. Method for dividing the cell-stuff bundles and drawing out of the fibre: The present invention forms a method, to divide cell-stuff, especially sulphite cellulose, thoroughly with preservation of the long fibre. This could not be achieved heretofore, because the dividing of the boiled cell-stuff by mills and refiners was imperfect to such a degree that the stuff always contained undissolved, connecting fiber bundles, so-called splinters, which had to be removed by special splinter-fangers. By the present dividing method, a stuff entirely free of splinters is claimed to be obtained, so that the splinter-fangers can be dispensed with.

The loosening of the cell-stuff is done in such manner that the boiled cellulose, after it has passed a draining apparatus, goes through two rollers, which revolve with different velocity and of which practically the slower revolving roller has a larger diameter.

The rollers are so finely adjusted that only the thicker particles, not quite boiled soft, are affected. These consist of connecting fibre-bundles and exist in the finished cellulose under the name of splinters, and they are crushed, and in consequence of the unequal velocity of the circumferences ground and dissolved into separate fibres. The single fibres, already produced in boiling, are, because the rollers are adjusted only for the thick fibre bundles, scarcely touched and cannot, therefore, in passing the rollers be torn by them. They thus retain their original length.

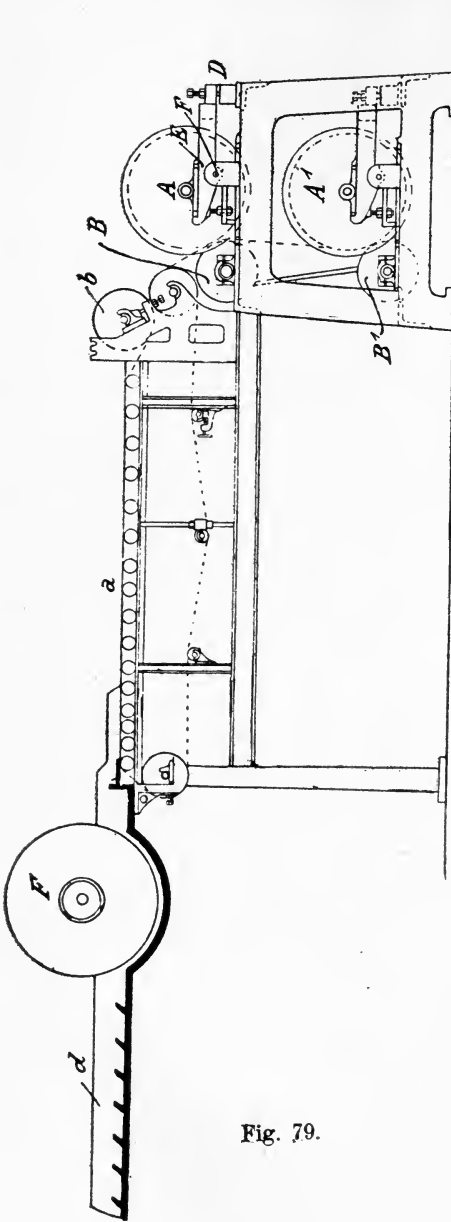

Fig. 79.

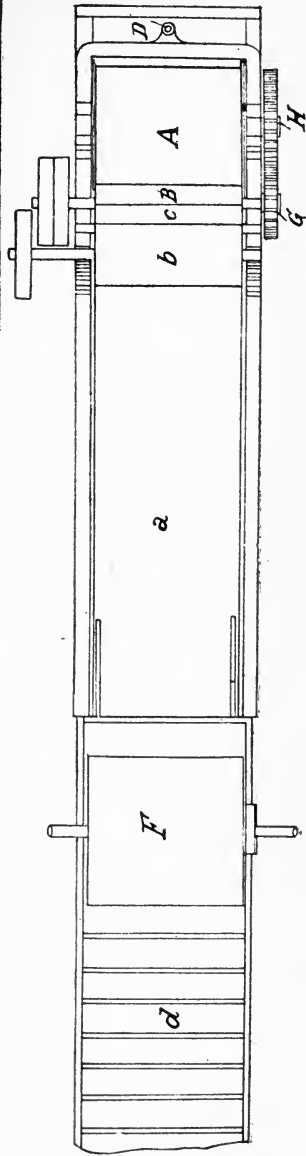

Fig. 80

In case the cellulose should, after passing the rollers, still show small splinters, it is made to go through a second or through several such differential roller pairs.

In working the method the arrangement, represented in the illustrations Fig. 79 side view and Fig. 80 plain is used.

After the boiled cellulose has passed a sandpan g and a wash-drum f, it goes to a draining arrangement of any kind, which in the present case consists of an endless wire sieve a, and two press-rollers b and c, between which goes through the sieve a with the cellulose laying upon in thin layer. The press-rollers remove all water from the cellulose, whereby it becomes so compact that it leaves the rollers in the shape of leaves or sheets and in this condition it enters at once between the rollers A and B, rotating with unequal velocity of their circumferences, where the splinters or fibre-bundles are separated.

The roller B is set fixed, while the slower rotating roller A is set in a fork E, which turns in the boxes F. The fork E is adjustable, in front by a set screw D and in back by set screws C. By means of these screws, D and C, the roller A is so adjusted to roller B that only the splinters and fibre-bundles are caught by the rollers, whereas the single fibres pass free between. The rollers are driven by a pulley, set on the shaft of the quicker rotating roller B. The roller A is driven by the roller B by means of the gearing G and H.

For greater safety the cellulose is run through a second similar pair of rollers A1 and B1. By the crushing of the splinters between the rollers AB and A1 B1, the leaf-like continuancy of the cellulose is not injured. By employing these differential-roller pairs, a stuff is obtained uniformly fine and pure.

2. Sieve drum for assorting the knots and coarser parts from dissolved cell-stuff:

The present invention forms a sieve-drum for assorting the knots and larger particles from dissolved cell-stuff. It is characterized by a simultaneous shogging movement besides the revolving. To this purpose the sieve-drum with one end set in a traverse, is by lever and pallet wheels made to have a short, shogging up and down motion, while the drum is turning. In the following illustration, Fig. 81-83,

are represented two connected sieve-drums in front and side view and in plane.

In a box-like frame B, open on top rest the two sieve-drums A, the mantles of which are perforated; each sieve-drum (fig. 81, left) is closed by a headwall b, possessing a large central opening c, lined by a ring d, extending outward, and at the same time forming the front resting pin for the drum. The back end of each drum is open. The

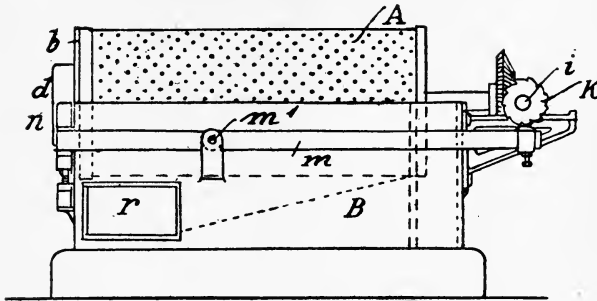

Fig. 81.

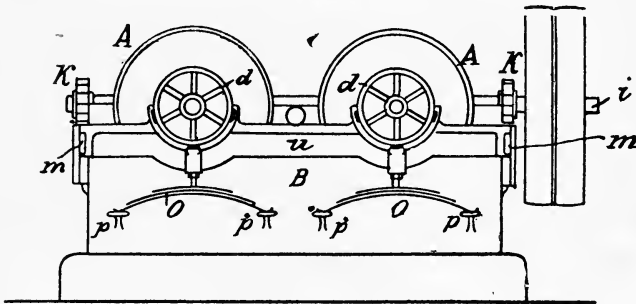

Fig. 82.

back resting for the drum is formed by its driving shaft f, fastened in the usual manner in the navies of the heads of the drum, and at g (fig. 83) it rest on the frame. The shaft F receives its revolution by means of the beveled wheels h h1 from the spindle i, which is rested squarely in front of the back end of the drum A in corresponding boxes of the frame and carries the pallet-wheels k and the driving pulley. The pallet wheels work against the ends of

the levers *m*, somewhat extending above, which at both sides of the frame *B* are set revolving about the pins *m1* and at its other ends carry the traverse *n*, laying square in front of the other end of the sieve drum, in which are rest-

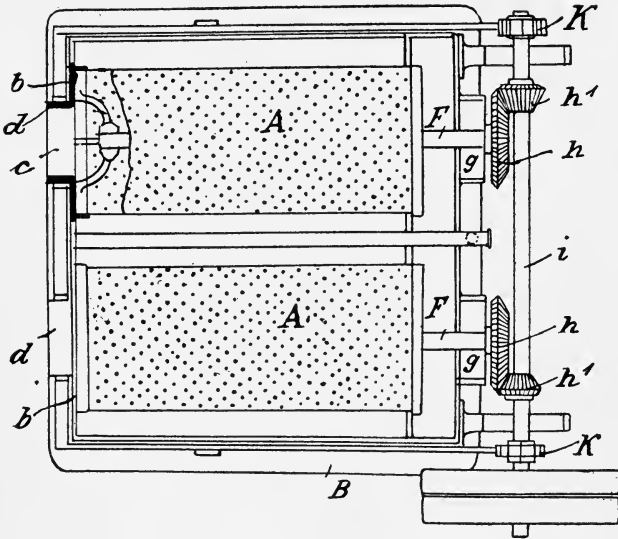

Fig. 83.

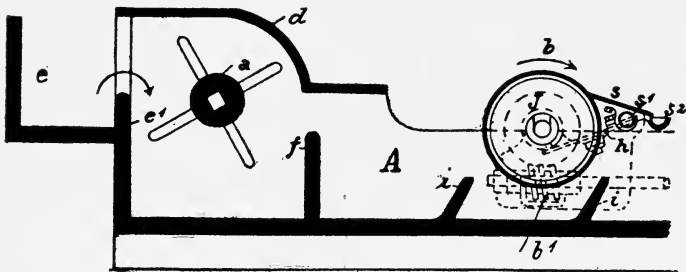

Fig. 84.

ed and revolve the extending rings *d* of the front drum walls *b*. Two springs *O*, which are braced against the traverse *n* and also against the intensions *p* of the frame, tend to lift the traverse with the front ends of the drums.

By the rotation of the shaft *i* the drums *a* are caused to revolve and at the same time, by the pallet wheels *k*, the

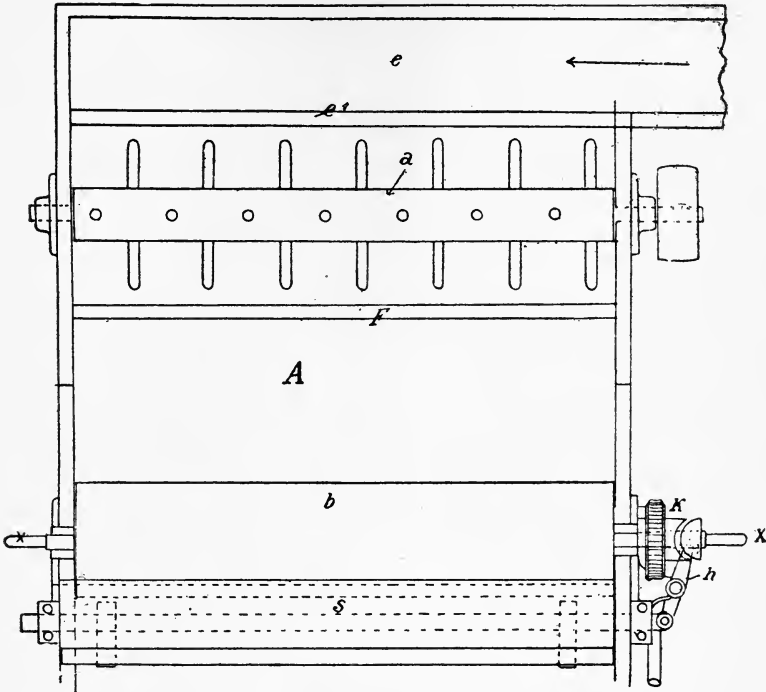

Fig. 85.

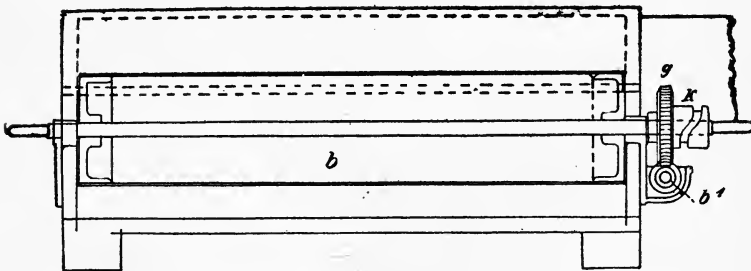

Fig 86.

levers *m* and the springs *O*, the traverses *n* and the front ends of the drum are caused to make short, shogging up

and down motions. The dissolved cell-stuff flows through the opening *c* into the sieve-drums and through the holes in the mantel of the drum into the lower open space of the frame *B*, from where it is taken away through the opening *r* (fig.87). The knots and coarser particles fall out at the open back end of the sieve-drums.

3. ARRANGEMENT FOR DERESINATING THE CELL-STUFF.

The arrangement consists in the main of a beater shaft, which beats the cell-stuff separating the particles of resin from the cell-stuff fibres, until a lather is formed, which after the liquid has come to rest, leaves upon it a fine film, containing the particles of resin. There are also of one or more rotating rollers, immersed in the liquid, and removing the particles of resin, the latter adhering to the mantel face of the rollers and removed by scrapers. The rollers may be cooled or warmed, as desired. In the following illustrations fig. 84 represents a long section, fig. 85 the plane and Fig. 86 the sectional cut through the roller *b*.

In the trough *A*, conducting the cell-stuff mass to the sandfang, is arranged a beating spindle *a*, covered with a cap *d*. The cell-stuff flows from the supplying trough over the wier *e* to the beater *a*, which so beats the cell-stuff, that a foam is formed, in which the particles of resin accumulate. Behind the beater the cell-stuff flows over the cross-wall *f*, behind which the foam disappears and leaves a fine resinous film swimming on top of the cell-stuff, which by a roller *b*, immersed in the liquid and slowly revolving, opposite to the direction of the current, is taken up, the particles of resin forming the film adhering to the lower face of the roller. The resin is then removed above the liquid by a scraper *s*, trailing on the roller. The scraper *s* rests on the pin *s1* and at its back end it is provided with a jutter *s2* to receive the resin. It receives, besides, by a lever *h* and a curved groove *K*, an oscillating motion, whereby the scraping off of the resin is facilitated. The curved groove *K* is worked into the wave of worm-wheel *g*, sitting on the spindle of the roller *b* and receiving its rotation from a worm *g1*. The roller *b* is arranged almost over the first cross-piece *i* of the sandfang. If desirable, several such rollers *C* can be arranged one after the other.

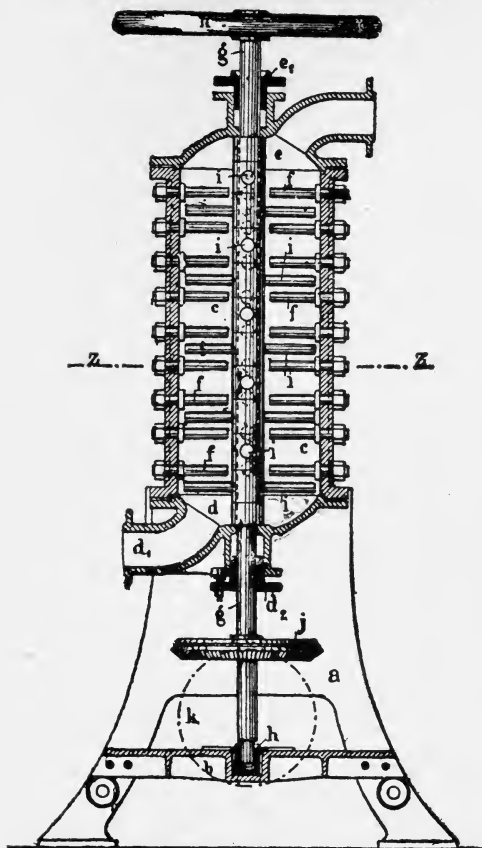

Fig. 87.

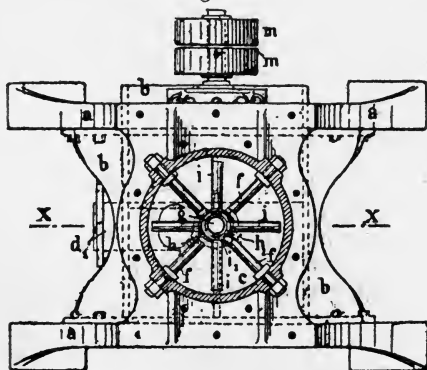

Fig. 88.

A machine for the same purpose is the Twirler of Carl Ziegelmeyer, described in the *Papier Zeitung*, 1895, and represented in Figs. 87 and 88.

It consists of a cylindrical mantle, to which are screwed fast a number of beating pins *f*, four each in one plane, between which move the beating pins *i*, wedged in the vertical shaft *g*. The number of the beating pins may be increased or lessened as desired. The shaft is set in a step box *h* and carries the fly wheel *n*, the two stuffing-boxes *d*² and *e*² are parts of the cover, closing the cylinder. The driving is effected by loose and fixed pulley *m* and beveled wheel *jk*. The two supports *a* of the strong frame are connected by a plate *b*, carrying the before-mentioned foot box *h*. The diluted stuff, mixed up with water, is by a pump pressed through pipe *d*¹ into the lower part *d* of the cylinder, on its way upwards being divided by the beating pins, and flows from the upper part *e* off through the pipe *e*¹. By the above described arrangement of the beating pins a twirling motion is produced in the inner space *c* of the cylinder, dividing the fibres, but leaving the hard particles unchanged. Because the cylinder is closed and over-pressure exists in it, the stuff while going through is protected from soiling and also from lubricating oil. A twirler, the cylinder of which has a height of 1.2 m. and a diameter of 0.4 m., suffices to dissolve about 5,000 kg. cell-stuff, boiled dry, in 24 hours, and requires but 1.5 square meters of ground. The consumption of power is 2 to 3 horse-power. The twirler has proved successful for eight years, in soda, as well as in sulphite stuff factories.

The firm of Goetjes & Schulze, in Bautzen, builds for dissolving and fibering cell-stuff the patented machine illustrated in the following five figures:

For this machine, after soaking and grinding the stuff, the removing of the latter, as well as of the insufficiently boiled particles and other impurities and admixtures is effected in a specially arranged sievedrum, whereafter the stuff is ground fine in one or several centrifugal mills. By grinding fine is here to be understood the complete dividing of the fibrebundles, not the crushing of the fibre.

Fig. 89 is a sideview with partial section; fig. 90 is the head view of the machine. The fig. 91, 92 and 93 represent details. The stuff as discharged from the digester is fed to the machine at *a*. It reaches the drum *A*, in which

is turning a shaft $a1$ with beating pins $a2$ (fig. 91); the drum A, made of bronze or other acid resisting material, widens a little from the inlet towards the outlet. By the beating and throwing action of the pins $a2$, the fibrebundles are softened and loosened. By partition walls $a3$, set against each other, partially barring the cross space, the stuff can

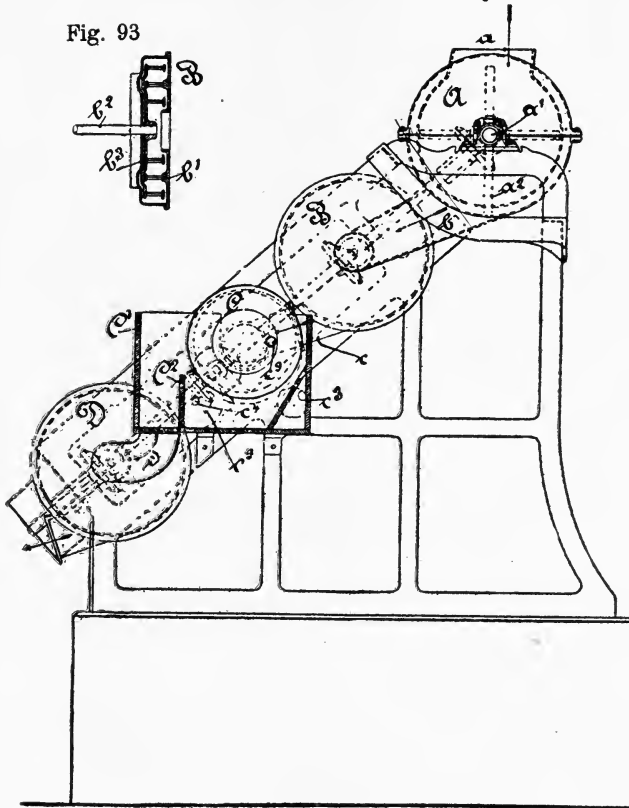
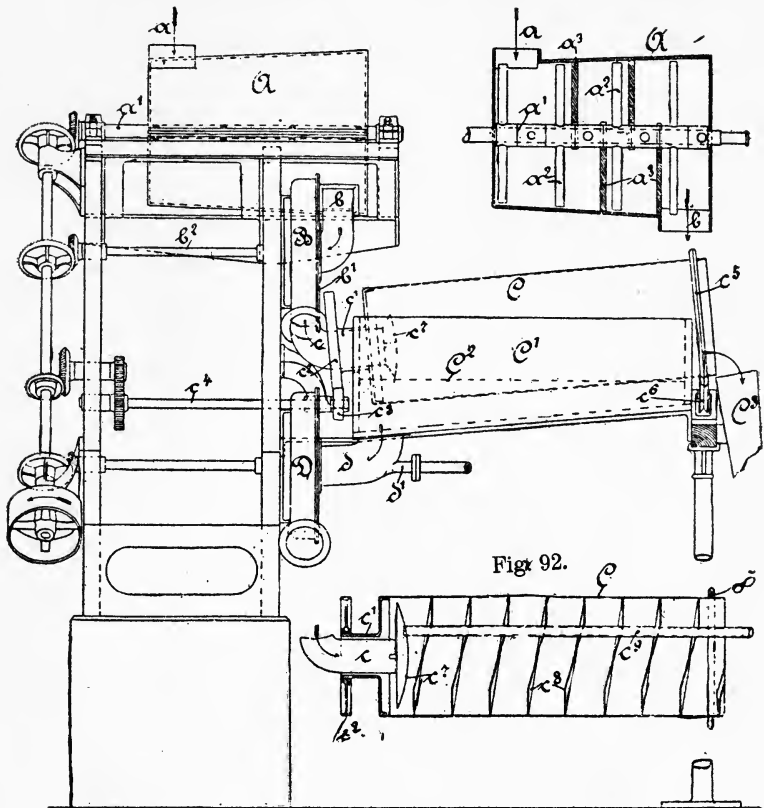

Fig. 89.

be directed along a zig-zag way through the drum, whereby the rim of the stuff is retarded and the working by the shaft a becomes more effective.

After the stuff has left the drum A at b , it is in a pasty condition carried to the centre of the centrifugal mill B.

In this (fig. 92), which is of the usual arrangement, opposite the fixed head b1 is set on shaft b2; the rotating head b3, both heads are set with beating pins of square cut. The object of this centrifugal mill is the previous grinding of the stuff, as against the grinding fine, to be described later on. It is the purpose to continue the softening and



Figs. 90, 91, 92.

loosening, commenced in A, until the dividing of the fibre-bundles, but most of all to bring the stuff in a condition in which the knots and other impurities or admixtures are separated from the cellstuff, without being ground.

This separating of the knots, etc., is effected in a sieve-

drum, C, into which the stuff enters through the bent pipe c, starting at the circumference of B.

The hollow neck c1, at the left side of the drum, carries a disk c2, with which the left end of the drum is resting on the friction and guide-rollers, c3, of which one is wedged on the driving pin c4. In similar manner the right end of the drum with a disk c5 of wedge-like shape is resting on grooved rollers c6. As perceivable from fig. 90 the axis of the drum has an oblique position, being lowered towards the entrance end of the left side. So far as the exit end the sieve mantle is immersed in a trough c1, filled with water and stuff. The bent pipe c is covered inside the drum by a cap c7 in such manner that the stuff cannot be thrown through the drum along the direction of the axis, but must leave c in a radial direction. The mantle of the drum is fitted inside with a winding alley c8 (fig 93); by a pipe c9. Water can be injected when necessary.

Whilst the stuff conducted to the sieve drum through pipe c is slowly moved on by c8, the sufficiently divided particles pass through the sieve mantle into the water, while the knots and such other matter are carried along by the spiral c8. The position of the axis of the drum to the level of the water causes the knots to keep swimming and not to be in the way of the passage of the stuff particles towards C1; until, nearing the end of the drum, they reach the mantle and are by the spiral carried to the shoot C3. In C1 besides the pure stuff are now also contained the heavy impurities, which pass the sieve mantle; these sink to the bottom, while the stuff flows over C2 through the bent pipe d into the centre mill D for grinding fine, i. e., for thorough separation of the fibres. Through the pipe d1 water can be supplied to this centrifugal mill, should it become necessary. Its inner arrangement corresponds to that of the already described centrifugal mill B.

Also based on the principle of centrifuging, Hagemann & Co. have built a patented wet, centrifuge with circulating vessel for milling cellstuff after digesting. This centrifuge is arranged over a cylindrical pipe g, the upper edge of which is formed into a ring-like closed box c, the cover of which also answers the fixed peg-ring of the centrifuge. The shaft l, which carries the upper, rotating peg-disk f and the axis of which falls together with that of the pipe g, goes through the bottom of the circulating

vessel and is consequently intended to be driven from below. The pegs *d* of the fixed ring are provided with axial bore almost up to the point, communicating with the ring box *c*. This is connected with a water supply through a pipe *b*, from which the water enters the bores of the pegs under pressure. From these the water is forced through small holes, divided along the pegs and against the pegs *e* of the revolving disk *f*. To prevent the water from getting outside along the face of the disk *f*, it is of advantage to cut grooves in the rotating disk *f*, over the peg-ring of the fixed disk, i. e., over the water outlets, in order that the water may be turned off downwards and led between the pegs. These, with sufficient velocity of rotation, atomize the water and throw it out with great force tangentially; whereby it acts with suction similarly to the well known ejectors. The stuff standing in pipe *g* but little below its upper edge, is therefore sucked up, fed to the centrifuge and by it filtered and mixed. The stuff now thrown out by the centrifuge, with great force, is with advantage thrown against a concentric wall, whereby it suffers further division. From this wall the stuff *f* then flows either directly or through a trough or channel into a suitable vessel, which communicates with the lower end of the pipe *g*. In this manner a circulation is obtained which makes it possible to run the stuff through the centrifuge as often as desired.

When the stuff at the same time is to be washed, as is always desired in the milling of cellstuff, it is practical to give the circulating vessel the form of the hollander tank, in which there are then arranged the washdrums in the customary manner. When washing the water can be continuously supplied through the lower pegs of the centrifuge, whereas when only fibring or mixing of the stuff is in question, the water is but supplied to the pegs only until the stuff is sucked up, when the water supply is then shut off.

The described centrifuge is arranged in the middle of a double hollander tank *U U*. The hollander box and the frame of the centrifuge are made of cement and only the working parts and valves, etc., have to be made of metal.

When the circulating vessel *U* is sufficiently filled with stuff, the shutter *a* is opened. The water now enters from the pipe line *b* into the ring-like box *c*, and from there in

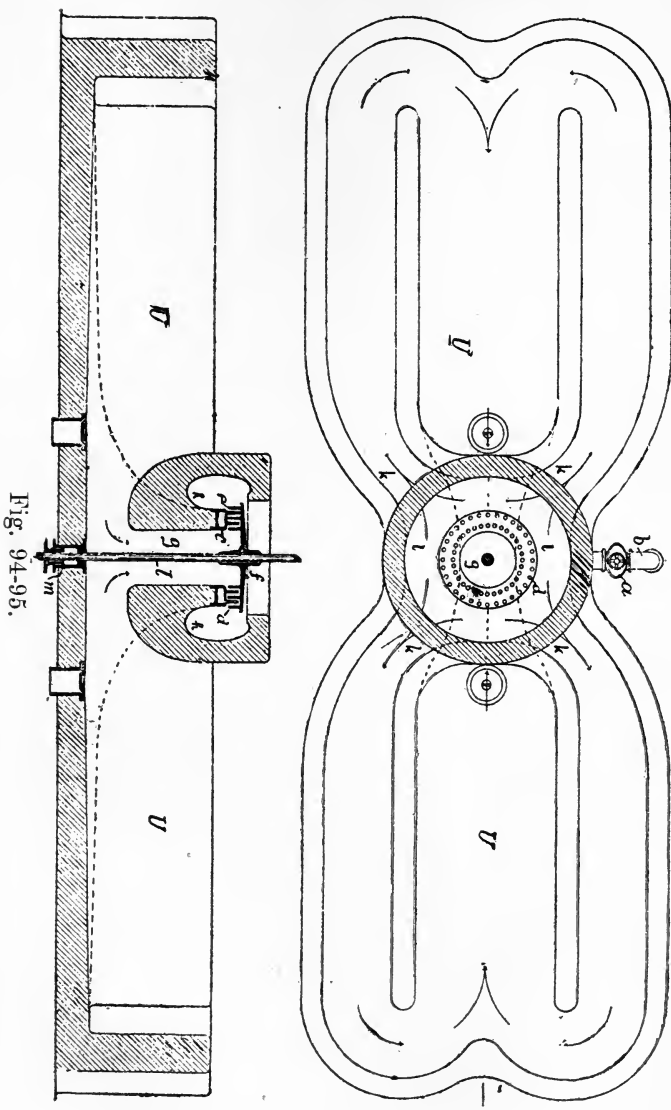

Fig. 94-95.

to the pegs *d*. From these the water spouts through the already mentioned small holes against the pegs *e* of the rotating disk *f*, which atomize and throw it out; the stuff thereby sucked up rises in pipe *g*, passes the centrifuge and is thrown against the walls of the ring-channel *h*. From this channel, on which are formed four saddles *i* for the equal distribution of the stuff, the latter flows through the four openings *k* into the outer compartments of the three-parted hollander tank. The arrows mark the further circulation of the stuff until it reaches again the centrifuge.

A simple arrangement for the separating of the cellulose from the waste leach has been patented by George Seiler and Franklin Emig, of Spring Forge, Penn. (American patent No. 514,780.) It is described as follows:

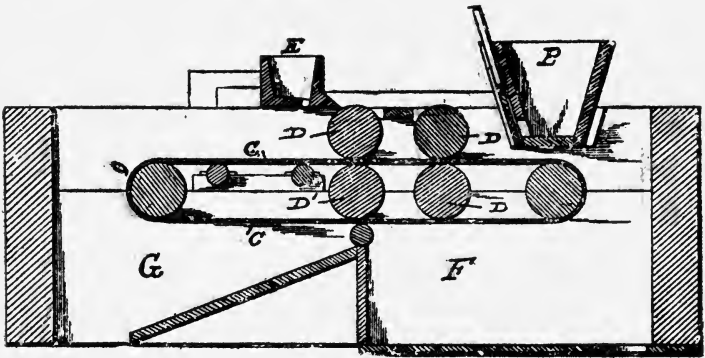

Fig. 96.

To separate the cellstuff from the waste leach as completely as possible without employing wash water, the cellstuff coming from the digester, saturated with leach, is run into the funnel *B*, from where, after opening a slide, it falls on an endless, penetratable ribbon *c*, (for example a sieve,) which carries it through one or more pairs of press rollers *D D* and then, in dry condition, into the space *G*. In this space it is so much diluted by water, supplied by the channel *e*, that it can be pumped to any place desired for further working. The waste leach accumulates in the compartment *F* without becoming diluted at all.

For milling the boiled cellulose, Karl Kellner had pat-

ented under Am. pat. No. 489,079, the following described machine:

By this invention the knots, undissolved in boiling, are prevented from becoming disintegrated and getting into the paper. The case of the machine, as seen in Fig. 98, is

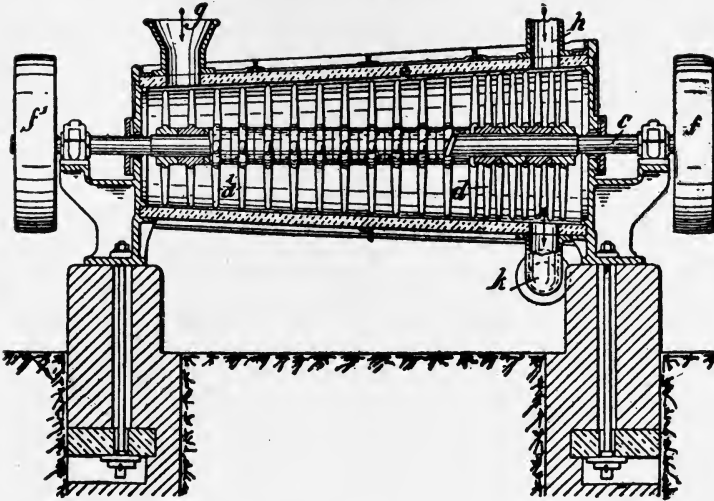

Fig. 97.

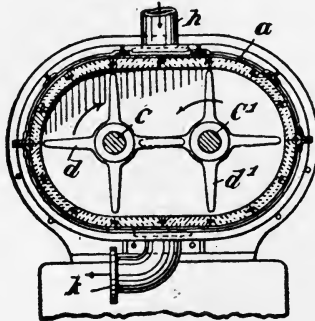

Fig. 98.

almost elliptical in cross section and conical in such manner that from the end where the cellstuff is introduced (g) it becomes wider towards the other end. The dividing of the cellstuff is effected by beaters d and d1, which are fast-

ened to the naves wedged to the shafts *c* and *c1* and with these naves form one piece each. The beaters of the one shaft move between the beaters upon the other shaft, without touching them, so that the knots are left uncrushed. Corresponding to the conical form of the case, the beaters become longer from one end to the other. To facilitate the discharging a pipe *h* is arranged opposite the exit pipe *k*, through which the water is supplied. The cellstuff is introduced in the condition of a thick, half-dry dough. The two shafts, *c* and *c1*, are driven in opposite directions by means of pulleys *f* and *f1*.

Another arrangement for the milling of boiled wood and the separating of knots from the stuff is that of Phillip Dietz.

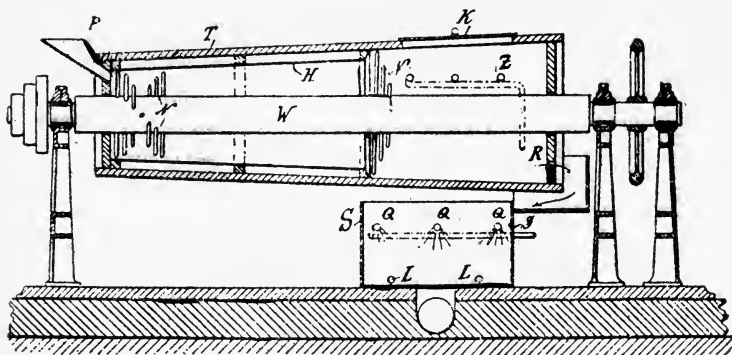

Fig. 99.

The arrangement consists mainly of the conical drum *T*, inclined on one side. It has, where its diameter is smallest, the inlet opening *P* for the boiled wood ;at the other end, where the diameter is the largest, the outlet *R* for the pasty stuff and also an opening for cleaning *K* are arranged. The narrow part of the drum is lined with a pad or cover *H*, of rubber, felt or other material. In the wider part of the drum are arranged three copper water supply pipes *z*.

To the shaft *W* of the drum are fitted the spokes *N*, along a spiral line; the latter, together with the shaft, are covered with a pad of rubber in such manner that between the lining of the drum and the ends of the spokes a free

space is left. At the outlet R stops are fixed adjustable to make a stopping of the stuff possible. Further, for further division, a pro-sorting box S is arranged with the sprinkle pipes Q and the outlet openings L.

The boiled wood, which is conducted from the digesters or storage room to the inlet P, is worked dry in that part of the drum in which is the padding H. By the latter as well as by the padding of the shaft and spokes is prevented the crushing of the hard particles of wood and of the knots.

The spokes N push the stuff ahead in such manner that each of them works the stuff ahead to the next one. In order to be able to change the number of revolutions of the spokewheel quickly, step-pulleys are employed. While in the upper narrow half of the drum the soft-boiled parts are separated from the knots, in the lower wet part, the flocks are completely fibred and dissolved. The stuff passes gradually over the wier and then receives liberal addition of water. In the pro-sorting box S the knots, as well as unboiled particles of wood and other admixtures, next settle down. After the fibres still adhering to the knots are removed by the sprinklers, before they can settle to the bottom, the stuff is finally conducted to a trough or sandfang of the customary construction.

After the single rolls are wrapped in good packing, papered and corded, or packed otherwise, the product is ready for shipping, but care must be taken that before packing sufficient samples are taken that the amount of moisture, which in shipping goods in moist condition form an important item, and often causes differences, can be determined as closely as possible.

The working of moist cellulose is very convenient for the paper manufacturer. Lately, however moist cellulose factories have provided for drying cylinders and thus formed the wet machine into a regular paper machine, able to produce absolutely dry stuff or almost dry, of about 80 to 90°, and thus to save freight expense or to be able to sell the cellulose in far-off markets with profit. Fortunately the drying is not of much disadvantage to the paper manufacturer, although it is claimed the fibre loses some of its firmness; but it dissolves easily in water and offers the advantage that it can be kept in store for any length of

time without danger of getting musty, as happens easily with moist straw stuff.

Some factories, shipping the cellulose in moist condition, who have to serve their customers a specially pure product, after having finished rolling are doing another sorting by repeated off and up rolling, which is done with a small apparatus, represented in Fig. 100 and 101:

An upright frame A carries several boxes; in the lower one is set a spindle, on which is fitted the roll B of cellulose to be assorted; above are arranged two guide rollers c and d and further up a strong wooden roller E (200 mm diameter) which by a belt from the transmission is slowly turned (8 revolutions per minute). Over it are arranged two forklike slide boxes, in which is laid the roller on which the cellulose to be sorted is rolled up. After a roll of cellulose is put in below, and drawn over the guide rollers and the wooden roller E and around the roller f, the winding up will start above. The cellulose breadth, as a rule 1 meter wide, is slowly moved upward in the direction of the arrow and the roll B is gradually rolled off. At both sides of the frame girls stand to pull out all impurities or larger splinters with their fingers, while the machine is going. When the girls are careful the result of the sorting is good, but the expense in wages is not small, several sorting frames are necessary (about three for every digester) and besides the loss of stuff amounts to 15 per cent, which, however, is used again along with the second quality.

All those cellstuff factories, which work for export, are required to perforate the dry cellstuff boards, that they are not taken for real pasteboard by the revenue officials, and as such taxed higher. This was formerly effected by arranging a pipe under the sieve, by which periodically strong jets of water were sent from below through the stuff-mass. Thereby, however, strong edges were unfortunately formed around the perforations, which in pressing caused unequal states of dryness.

Because the government now requests regular perforation, different apparatuses have been constructed.

One of them, built and patented by the Kuehule machine factory in Frankenthal, is described and illustrated in the *Papier Zeitung*.

By this arrangement the perforating of the paste is done

on the wet machine in such manner that the cellstuff cannot be taken for pasteboard by the revenue authorities. The dies and sinkers, which are fixed to a frame swinging around an axis, follow the finished sheet of dry stuff, while perforating and there at once return to starting position.

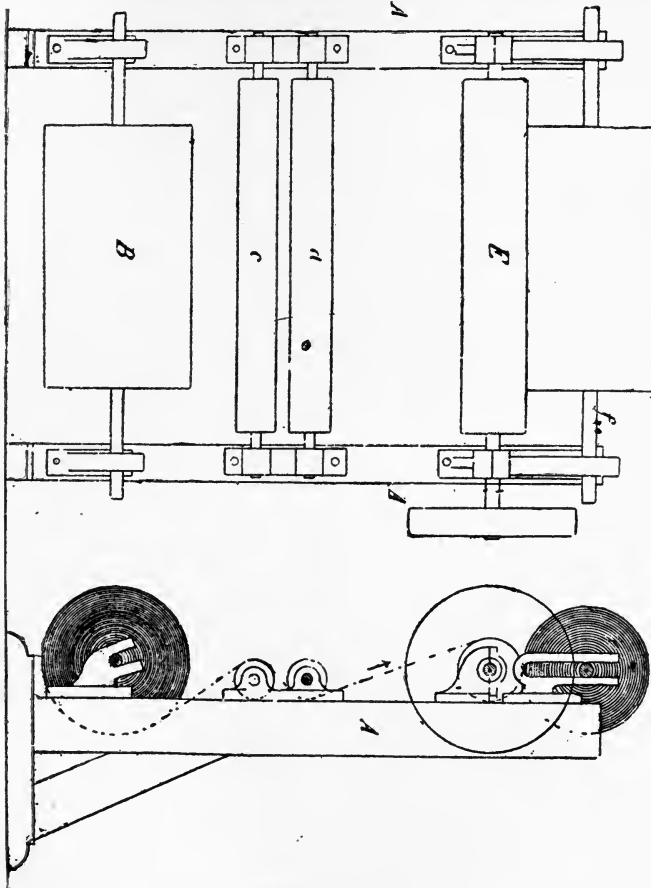

Figs. 100-101.

As advantages of this arrangement are claimed:
 First.—Faultless perforation, i. e., no injuring of the good appearance of the stuff by the perforating; second,

preservation of the expensive transport sieves, against the method of perforating by water jets and others; third, convenient application of the arrangement to any machine.

A much more simple arrangement for perforating cell-stuff board is the one of H. Fullner in Warmbrunn. An upper roller is provided with pins, which fit into corresponding holes of the lower roller and cut just as many holes into the stuffboard. The pins are edged on the outer face, in order to make an incision and not tear through. A scraper, laying against the upper roller, holds back the shreds possibly adhering. It may be conveniently taken off the board of stuff if necessary and is provided with notches, which permit the pins to pass.

The upper roller, with the pins of hard steel set in, is of cast iron, whereas the counter roller with the holes is made of steel tube so that the edges of the holes form steel-cutters, working together with the steel pins. The perforator can be made so that all four sides of the pin cut, and the pieces of cell-stuff board cut out, fall into the hollow space of the lower roller; they accumulate there, until pushed to the ends, where they drop through four round holes into the wooden boxes standing under.

If the square clippings of cell-stuff should stick to the cell-stuff pieces, only three sides of the pins are made to cut, so that on its back side the clippings are left connected with the piece. The piece is then passed under a strike-board, which turns the clippings over and by rollers they are so pressed against the drying cylinders that the turned over clipping will stick to the piece and leave the holes entirely open.

The perforator is mostly connected in the paper machine between pressers and dryer.

Many factories sell part of their production in bleached state and then up to rolling up and assorting treat the cellulose in the same manner as described above, after which an ordinary bleaching hollander is employed. This should be of at least 300 kilos hold of stuff. Let it first be almost filled with water, warmed by steam and then from a box standing near the hollander, and holding exactly the quantity of the chlorine water necessary to be added, ($1\frac{1}{2}$ cubic meter for above quantity of stuff) the chlorine is let into the hollander. Then is introduced the stuff, the damp cellulose, wound up in rolls. In about three

hours the bleaching process is finished and this is followed by washing, which requires one hour, and then the bleached cellulose can be let into the stuff-tanks, from where it goes to the before mentioned drainer and is wound up again in rolls.

For several years there has been used for the bleaching of cell-stuff a hollander which varies from the ordinary form, but possesses highest efficiency, because it effects closest and quickest mixing of the stuff with the bleach water and with the utmost cleanliness. It is the wash-bleach-hollander built and patented by Emil Nacke, which is made in large dimensions: 9 m. length and $4\frac{1}{2}$ m. width, inside measure, and holds 1400 kgr. stuff.

The moving and mixing of the stuff is not done by paddle wheel, but by a turbine-like wheel of 650 millimeters diameter, which is arranged at the bottom, makes 200 revolutions per minute and is driven by a belt from below, so that of the driving mechanism nothing at all can be seen. By this wheel the stuff is moved around noiselessly. The current is so strong that the stagnation of the stuff in the corners is entirely obviated and the use of stirrers is unnecessary. Except with the walls, which are lined with white tiles, the stuff comes in contact with nothing but phosphor bronze and glass, which substances are resistant against acid and chlorine and hence clean. The wheel *f*, which rotates above the bronze plate *a*, is of phosphor bronze and the plates *b* and *c* are of glass. The stuff, moving in the hollander towards the wheel, is by the inclined glass plate *b* turned downwards, then, as the arrows show, sucked off by the wheel and after going through the wheel leaves at its circumference in current: spreading in the form of a fan. The stuff leaving the wheel toward the front produces a strong undercurrent close to the bottom of the hollander, by which all settling of stuff at the bottom and in the corners is prevented. The stuff leaving towards the glass plate *b*, is by this and the glass plate *c*, as the arrows indicate, also turned towards the front and forms together with the under current the strong draft of this hollander. The difference between the levels of the stuff in front and behind the plate *b* amounts to three-fourths meter and by this in fact is conditioned the lively current of the hollander. The mixture produced by the hollander is al-

ready a perfect one after once going through, so that the chlorine water introduced at one place, after going but once through the wheel, is mixed quite uniformly with the stuff. In the same even manner the heating of the stuff is done by a current of steam let in; the temperature of the stuff, even in the largest hollander, is thereby increased about the same all over; so that the temperature can be made the most favorable for the bleaching process, without part of the stuff becoming heated the fraction of a degree above or below.

The Nack hollander has inside of the tank no hidden corners and nooks, every part of it lays entirely open to the eye, after the stuff is let off. This, together with the clean, acid and chlorine resisting material, is an important advantage, where the production of the purest stuff is the question.

Because the hollander is also used for washing, Nacke also uses a washdrum, not the ordinary one, however, but an aspirator wash-drum of his own system, which works so easy that it does not require special power, but is driven by the motion of the stuff. Gearing and belts with their uncleanness are therefore dispensed with. This wash-drum furthermore also washes much more energetically than the ordinary dipping washdrum and has over this the other advantage that the sieve lining lasts twice as long and the loss of fibre in washing is much less.

The arrangement is as follows: The washdrum is a simple cylinder, provided with a fine sieve lining, turns loosely on a hollow, fixed shaft, on which, inside of the drum, are set three aspirator pipes, open below, turned downward into the water. Because the shaft is fixed these aspirator pipes maintain their downward position. Outside of the hollander wall is screwed to the hollow shaft a long fill tube, dipping into a box, in which is a partition of adjustable height, permitting the regulation of the quantity running off. The deeper the weir is set the stronger the drum will suck. To complete and maintain the vacuum a small aspirator is used, it is driven by water, which is supplied by a hose under four meters pressure or more. The hose is 20 mm. wide, but the bore in the aspirator is only 5 mm., the consumption of water is consequently very small. Through a second rubber hose the consumed water runs off into a tank. The

first water-supplying hose must be long enough so that the drum can be entirely lifted out when no washing is to be done. In the other case, the washdrum is let down by a set-wheel, so that it immerses into the stuff, displaces it somewhat and lets the dirt-water penetrate through the sieve-lining into the interior. The rotating stuff at once

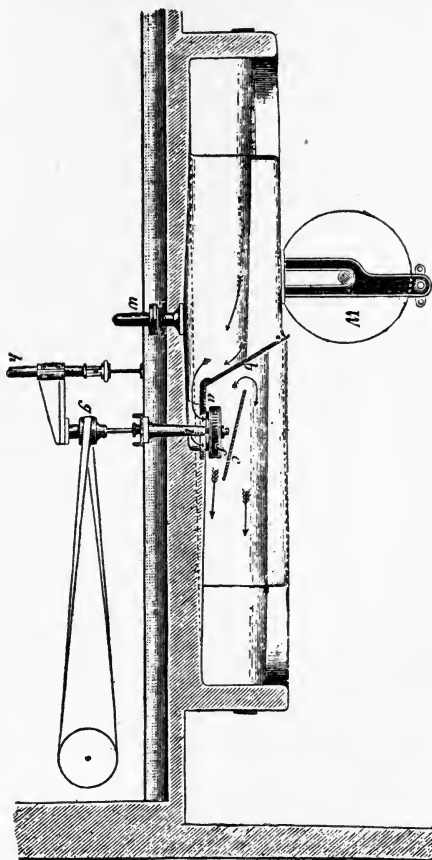

Fig. 102.

sets the drum into revolving motion so that it is continuously offering a face to the penetrating water. The aspirating apparatus is set working by opening the water-

supply valve, a vacuum is caused in the hollow stuff, the dirt-water is raised up through the aspirating pipes, is received by the hollow shaft and conducted away by the outlet pipe attached to it, and because this is emersed in the box filled with water, a continuous aspirating of the dirt-water is affected.

Although the method is not yet introduced in cellulose factories, the electric bleaching, worked out by E. Hermite could be employed in place of bleaching with chloride of lime. This is claimed to yield a saving of at least 50 per cent in bleaching material. With wider extension of the latest Kellner method of producing cell-stuff by means of the electric current, this bleach would certainly not be necessary because as heretofore mentioned, by this a snow-white stuff is already produced. But for the sake of completeness this bleaching method should be mentioned. It is based on the following: When a solution of chloride of magnesia of 5 per cent. chloride of magnesia and 95 per cent. water is electrolized in a convenient arrangement, water and chloride of magnesia are simultaneously decomposed. The chlorine separated from the chloride of magnesia, and the oxygen, from the water, under the influence of the electrolysis, combine at the positive pole and produce a loose chlorine-oxygen combination, which is possessed of strongly decolorizing quality.

The hydrogen and the magnesium go to the negative pole. This decomposes water and forms magnesium oxide, while hydrogen is set free. When vegetable fibre is brought into such liquid, the oxygen combines with the coloring substance and oxydizes it; the chlorine combines with the hydrogen and forms hydrogen-chloride, which again goes into combination with the magnesia in the liquid and reproduces anew the chloride of magnesia. This circulation is repeated as long as the electric current is acting on the solution, holding the colored substance. To a perfect circulation of this kind are therefore necessary. First, electric current; second, chloride of magnesia; third, water; four, coloring substances.

Two of these elements serve to destroy the coloring substances; viz., the electric current, or, what amounts to the same thing, the acting force and the water. The chloride of magnesia serves continuously; only a simple

moving of the molecules takes place and the chlorine acts as a conductor, bringing the oxygen produced to the coloring substances. It has been proved that the electric method exercises a quicker decolorizing action than common chloride of lime.

In general Hermite points out the advantages of his

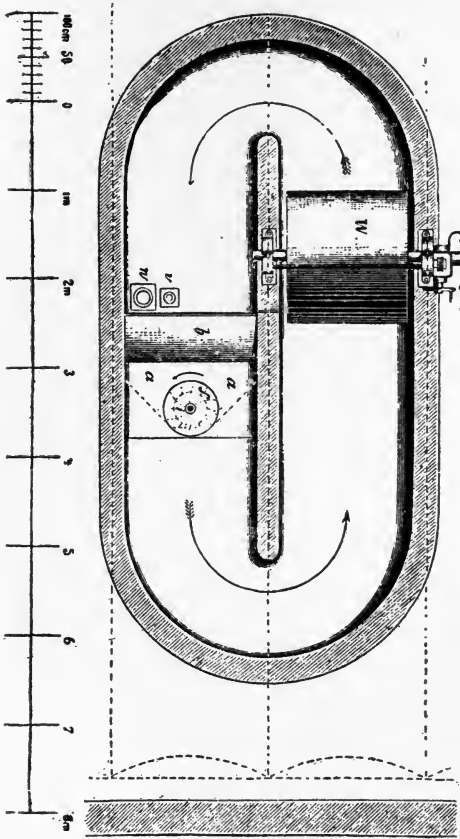

Fig. 103.

method as follows: First, it permits every bleacher to produce for himself the discoloring substances and this without noticeable interruption of his work; second, the decolorizing means is pure and does not leave a residue;

third, it possesses considerably greater decolorizing effect than chloride of lime; fourth, its action on fibres ensues quicker, is more uniform and is less injurious; fifth, its employment means considerable saving of money; sixth, the cost of production is uniform.

In this method only that part of chloride of magnesia is lost which is contained in the damp stuff after pressing. At 40 per cent dryness there are to be considered 40 kilos of stuff and 60 kilos of water; then for 100 kilos of dry stuff 150 kilos of chloride of magnesium solution gets lost, containing $10\frac{1}{2}$ kilos of chloride of magnesia.

The apparatuses for electric bleaching are built by Paterson and Cooper in London. The electrolyser consists of a cast iron vessel, in the lower part of which is let in a perforated pipe, provided with a zinc cock, through this pipe the chloride of magnesium solution enters the apparatus; its upper edge is flattened out, receives the overflowing solution, and conducts it to another vertical pipe. This second serves to create the circulation of the solution. Along the length of the electrolyser lay two shafts, to which are fixed disks of zinc; these disks of zinc are the negative electrodes and move in slow rotation. Intermitted with each negative electrode is set a positive electrode; the active surface of which consists of platinum netting held in a frame of hard rubber. The upper part of the platinum netting is soldered to a lead body and completely isolated. By means of this lead body every positive electrode is connected with the copper circuit, conducted through the electrolyser; the contact is effected by a female screw. During working any electrode can be taken out, without any interrupting of the process in the apparatus. In connection with the copper conductor to which the positive electrodes are fastened, is the positive pole of the dynamo machine. The electric current now distributes itself upon all platinum electrodes, goes through the liquid in the zinc disks, i. e., negative electrodes and connects by means of the galvanic cast iron vessel with the negative pole of the dynamo machine. For the purpose of keeping them clean elastic scrapers of hard rubber are arranged at the positive electrodes, tightly lying against the zinc disks. These they keep clean of every deposit while slowly rotating. The apparatus can be emptied by opening a valve.

When several apparatuses are used, they are set for intensity, i. e., the positive pole of the first is connected with the negative pole of the second, and so on. An electric current of 1,000 to 1,200 ampires is generally used to work the electrolysor.

Each apparatus substitutes the decolorizing action of about 125 kilos of English chloride of lime of about 33 per cent of chlorine in 24 hours of continuous work and requires about $8\frac{1}{2}$ horse power. The inventor guarantees for every electrolysor of 1,000 ampires current the substitution of the bleaching power of 100 kilos chloride of lime, and an expense for power of 9 horse power on the pulley of the dynamo machine in 24 hours work.

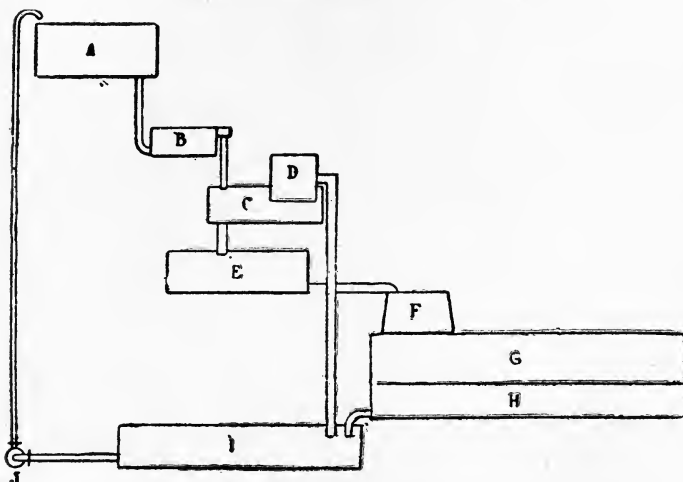

Fig. 104.

To represent the circulation arranged in electric bleaching, is the schematic figure, 104:

From the vessel A the solution of chloride of magnesium, to which some magnesia is added, enters in to the electrolyzer B and falls from there into the bleach hollander C where the decolorizing of the stuff to be bleached takes place. The wash drum D conducts the spent solution into the vessel I and the centrifugal pump J carries it back to the original starting point A. By means of this steadily maintained circulation the solution continuously keeps up

the same effectiveness. When the stuff is properly decolored it is, together with the solution still contained in the hollander, let off into the vessel E, where the after-bleach takes place; when this is finished, the stuff goes over the wet press G, where it is deprived of its water. The solution running off G is caught in the tank H, let into the main tank I, and from there, by means of the pump J, returned to the tank F. In special cases, when for instance difficultly bleachable stuffs are to be bleached, it is advisable to previously let the solution circulate for some time between the two vessels F and J; also the apparatus B. The solution becomes thus more effective and the stuff is bleached quicker. It may be mentioned that during bleaching an excess of free magnesia is ever required in the solution of magnesia chloride to maintain the latter neutral. It can be made at home in the following manner: In a high tank, filled to one-half with strong solution of chloride of magnesia, sufficient milk of lime is added. The lime produces a jelly-like precipitate of magnesia and leaves in solution chloride of lime. When the magnesia has well settled the solution of chloride of lime is drawn off by siphon and let to waste. The magnesia is then washed two or three times with clean water; it is then ready for use and is added to the bleach-liquid in small quantities as required. For the preparing of the milk of lime another tank with wash drum (the latter covered with very fine metallic cloth) is required. The wash drum draws out the milk of lime and leaves sand and other impurities in the tank.

In a Swedish cellstuff factory, during several years' bleaching according to Hermite's method, for each 100 Kgr cellstuff 11 Kgr tale are decomposed and it is claimed that bleaching with this method, although twice as much power is required than stated by Hermite, is still much cheaper than with chloride of lime.

In factories where the wood intended for boiling is cut by a chip machine and where consequently the pieces after the boiling, though they should partially be left hard, are never large, and where besides not much value is placed on the production of best quality, the work in the stampers and in the wash troughs is saved by crushing the stuff discharged from the digester directly by a large mill. From there the stuff is let into a basin, diluted with water and

directly or by means of a pump conducted to the hollander. Here it is beaten for some time, but not ground, and yet receives an addition of dilute muriatic acid, whereby the whiteness of the stuff is raised, afterwards going to the wet machine for finishing. Because in this method the knots are not all removed only a second quality stuff is naturally obtained.

In order to utilize as much as possible the knots and the stuff adhering to them, some factories use still another mill, which works up all waste and crushes also the knots, at least into small pieces. This milled stuff, which is left possibly dry, is scooped into a quickly rotating sieve drum of inclined position which sifts the stuff which can be made use of while all larger, hard pieces come out at the lower end. The stuff obtained is naturally very poor, but for sundry purposes, ordinary paste-boards, etc., it still finds employment.

In connection with the fibring arrangement in use until recently and previously described, C. Kleine and Ernest Kirchner have patented a method in which a rapidly rotating, so-called twirler is connected with an improved machine. The description reads as follows: According to the present invention the boiled stuffs, superficially washed in the digester or in special leach troughs, are drained off, *dan.*), or by adding of water in a moderately wet condition, are fed through funnel T (fig. 105) and by the worm B to a twirl, increasing towards the back, making about 300 revolutions. The twirl revolves in an entirely closed box of quadratic cross section with blunted corners below widening towards the back like the twirl. The damp or moderately wet stuff, regularly fed through T and by B, in so far as it is entirely boiled soft, is now by the arms of the twirl beaten into flakes or stiff paste, while insufficiently boiled or hard particles are completely separated from good fibres, but otherwise left whole. The screw-like arrangement of the arms and the widening of the box towards the back effect a gradual moving of the stuff to the opening provided at the widest part of the box, where the good stuff, together with the impurities leaves the twirl, as shown in the illustration, to reach through a drop-pipe or a special transporting arrangement the wash and cleaning arrangement. Here the damp, flaky, or thick and pasty stuff is diluted by plenty of water from the upper sprinklers E

and further divided by a mill-work arrangement C, whereby the large impurities are left whole. The latter settle to the bottom in the deep troughs by the water entering from the lower sprinklers E, i. e., by hydrostatic pressure, they are freed from any adhering good fibres and then removed to side tanks by mechanism H, similar to chain-pumps. Floating, light impurities are retained by wire nets at D; heavy particles, carried along, perhaps by the current and motion of the liquid, settle again in the troughs F and H, rinsed by water further entering from below, from where they are removed in the same manner. The now very wet stuff passes a sand fang K, of known construction; by one or several wash drums L, which are arranged directly in cavities of the trough, they are energetically washed and thickened. The thick stuff is now completely beaten or dissolved in single fibres by a moderately quick rotating rake-roller M with base-rake.

After leaving back of the rake-roller the stuff is again much diluted by a sprinkler, passes again a sand fang K² and several troughs N, where through the sprinklers G, arranged below water, enters again. Thus the heavy parts yet contained settle in the troughs N, against the hydrostatic pressure, while the good fibres flow on. The latter again pass a sandfang, are a second time washed energetically by one or several wash drums O and finally reach the stuff press, the setting boxes or the bleach hollander.

Because the splinters, as undissolved fibre bundles, as a rule are rather wide, but very thin, they pass easily through all these processes and through the fine slits of the knot-fangers, it is therefore recommended to pass the stuff through a refiner, the semi-circular slits of which are cut 1 centimeter deep. The refiner entirely dissolves the splinters and if managed rightly makes the fibres uniform, without injuring them. When the stuff is refined and thus free of splinters, it is very easily bleached and can be used for the best papers. The bleaching of sulphite stuff costs then not more than 2 to 3 marks per 100 kilo.

As by the best executed washing of the cellstuff, the brown digested solution, soaked inside the single fibres, can be removed but with difficulty, it is advisable to throw the stuff out after washing by a centrifuge. By this procedure the last traces of leach are removed and the stuff is more than otherwise susceptible to bleaching.

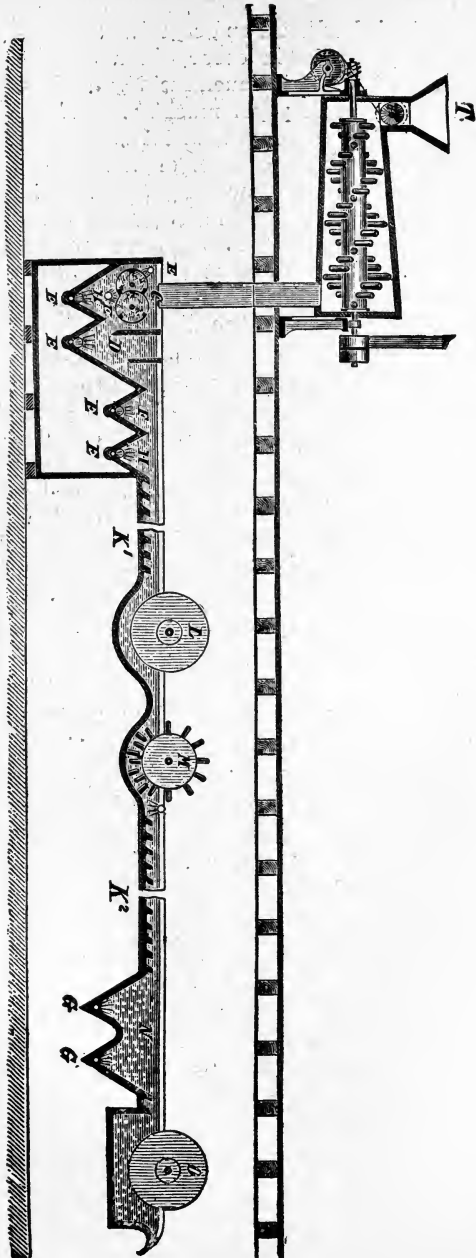

Fig. 105.

In poorly boiled cellstuff and especially waste, according to Mitscherlich, pieces often occur which are not sufficiently boiled, which still contain much resin and which work badly in mill, hollander and paper machine. It has been recommended to boil these pieces with 1 1-2 per cent. of the dry weight, with soda in the form of balls for two or three hours under 1 to 1 1-2 atmospheres pressure; whereby the resin is dissolved; also when milling such bad pieces, 1 1-2 to 2 liter of soda and 3 liters of petroleum is added to 100 Kg dry stuff. The mass must then be washed out in the wash hollander adding 1 to 1 1-2 liter of muriatic acid per 100 Kg stuff. Instead of the digester a large barrel with stirrer may be used, the contents of which can be boiled for two to three hours.

According to a method of Edward Partington, recently patented in England, the tar-like traces of resin often strongly adhering to the sulphite stuff may be removed by paraffin oil or any other carbon-hydrogen combination which is added to the stuff in the wash hollander. For 1,000 Kg dry stuff Partington recommended 7 to 9 liters of ordinary paraffin oil of 0.8-0.85 specific gravity, the point of inflammability lays between 17 and 490C.

VI. OFFENSIVE WASTE-WATER AND ITS PURIFICATION, CONTAMINATION OF THE AIR, PRECAUTIONARY MEASURES, STATUTES OF THE LAW.

More than by the difficulties of the very manufacture of cellulose, more than by the injurious influence of the sulphurous acid on all iron parts and on the durability of the digesters, more than by the damage done to the vegetation of the neighboring lands by the gaseous sulphurous acid escaping from the towers, more, much more trouble is caused to the manufacturer by the offensive waste waters, where the factory is not favorably situated to get rid of them conveniently and possibly unnoticed. The amount of the waste leaches and wash waters is so large, and the quantity of sulphurous acid still contained therein so considerable, besides the color so intense and the smell so disagreeable, that a large river would be required to let all this waste go directly into. But even then it would scarcely go without complaints, suits and damages, as the fishes especially are

sensitive to the least traces of sulphurous acid and easily become extinct. Therefore, when planning new cellulose factories, it must be considered essential that facilities for letting off the waste waters exist, either by suitable quality of the soil or by large water currents of velocity, and the inlet of the waste water must not take place close above a city, but below, as otherwise the molestations would never cease.

For a boiler according to Mitscherlich, taken for a basis, every four days and a half there must be disposed of 60 cubic meters of leach, just as much or more rinsing water and the still larger quantity of wash water. The off-leach is boiling hot when discharged and the running water also goes off quite warm. According to an analysis one liter of leach contained: Sulphurous acid, 3.86 grammes; sulphuric acid, 7.33 grammes; chlorine, 0.29 grammes. The residue dried at 110° C weighed 109 grammes. After calcination there remained a residue of 19 grammes, containing: Iron oxide, 0.02 grammes; lime, 10.30 grammes; magnesia, 0.30 grammes; potash, 0.28 grammes; soda, 0.10 grammes; a total of 11 grammes. There were consequently contained in one liter of leach: 90 grammes organic constituents, in one cubic meter therefore, 90 kilo; and in 60 cubic meters or one digester charge, the colossal amount of 5,400 kilos. This result would have caused surprise if the author had not himself ascertained by many experiments that for 100 kilos of finished cellulose 291 kilos of absolutely dry wood are required. Almost two-thirds are consequently lost, and these are made up by the knots, loss of fibre in manufacturing and the incrusting constituents, which reappear in the leach. Such an enormous amount of organic constituents, which color the leach quite dark brown, must certainly, even without considering the presence of sulphurous and sulphuric acid, cause a strong contamination of the water currents and must also in short time penetrate the soil of the environment of a cellulose factory, if, as is done as a rule, the leach is let off into a so-called leach pond. In consequence of the standing still in the soil, the leach will then soon grow rotten and, where perchance appearing, gives out a sickly smell. By this penetrating through the soil and all joints of mason work, etc., it is then quite obvious that all wells, nearby at least, which are either for domestic use, or furnish the water for

manufacturing, are easily ruined, and that therefore all possible protective means must be provided in order to effect absolute isolation. It is best to take care, when planning a factory, or better still when buying and selecting the site that the field, if not immediately situated on a large river, be somewhat hilly, so that at least the necessary water for manufacturing can be taken from the higher lying part, while the wastes should be let off or sunk as far as possible from the factory. No matter how large the river, the leach must not be run off at once, but, as the discharging of the digesters is repeated at certain intervals, the regularly renewed quantity must be led off in a small current, or during the night, which is best done by means of a gate regulated by a float; besides, however, the waste being composed of three parts, the digester leach, the rinsing water and the washings, the cooling off of the first two must be effected before. Therefore large cemented basins must be built or deep pools have to be dug and the leach and washings be let in there. Both wastes may also be collected separately. But because these steaming wastes still contain much sulphurous acid, which, if freely streaming into the air, would not only contaminate the surrounding atmosphere, but would also injure the vegetation of the neighborhood, the pools must be well covered, and this is best done by beams, laid over with bark and a layer of bark chips, which again are covered with earth. This best keeps tight and can be easily kept in repair.

As for the washings which contain traces of sulphurous acid, it is generally sufficient to conduct it away, as far as possible, through several basins, which by dividing walls are separated into several compartments. Then the fine cellulose particles carried along, which perhaps have passed a large stuff fang which the washings must first pass shall next settle. The stuff fangs may be rotating, or large flat boxes covered with fine wire netting. It is well to set into the first compartments bundles of brushwood, which easily retain the cellulose fibres and in a following compartment to let the water through a layer of limestone, mixed with pieces of manganese, whereby sufficient neutralization takes place.

But if, however, the water current at which the cellulose factory is situated is insignificant the discharge therein of all wastes will cause such contamination that complaints

will never cease and the stepping in of the authorities would necessarily ensue. Unfortunately it is very difficult to render harmless the sulphurous acid. The different experiments of chemicals and also all present methods of filtration, which with the dirty waste of other factories were yielding good results were of no success with the digester leach, as the disagreeable brown color could not be got rid of. Where therefore direct off-let into the river is not permitted, and sinking through sandy soil is not sufficient, nothing else is left to do but to dig several deep shafts down to the ground water and to let into these the cooled leaches and eventually the washings. This can only be done when the factory is situated quite isolated and human dwellings and wells are far distant in the direction of the descending ground water. But also in this case neutralization must be cared for. A method of chemist Leisenberg in Halle accepted by the government authorities and tried for some years, in cases where the leaches and rinsing are to be let through shafts to the ground water and the wash waters into the creek is as follows: Inside the factory, best in the washroom, are put up as high as possible three iron or wooden tanks, which all have water supply pipes, can be heated by steam and have stirring arrangement. The latter can also be substituted by a steam injector, as furnished by Koerting in Hanover, which permit forcible stirring of the liquid in the tanks. In the largest of tanks, of about four cubic meters, milk of lime is prepared; in the second ferrite and in the third aluminate is dissolved. All three liquids are steadily kept stirred up by the steam injector or other stirring arrangements. A pipe about 50 mm wide, which can be closed by a cock, leads from the lime tank to the point where the waste enters the above described waste pool, so that the stream of lime milk, uniformly running off, regulated by the cock can mix as thoroughly as possible with the wastes. The outlet pipes of the two other tanks discharge at a somewhat distant point of the pond and in a continuous weak current add the two other solutions to the waste already neutralized by the milk of lime. This method requires that the waste flow a distance of 100 meters or more, that it flows through one or more deep pools, where the current is so low that the lime can practically settle in there before the purified wash water can enter the river. It has been found that this method frees the

wash water of almost every injurious effect, as it does not become rotten or foul even standing for weeks. At the same time the color also becomes somewhat lighter. The same manipulation is employed in discharging the leach into the leach pond, but as this discharging is only done at greater intervals one large tank suffices there in which successively the lime, ferrite, and aluminate are dissolved and from there are mixed with discharging leach and the rinsings.

In cases where a sinking of the leach or dropping to the ground water is not possible or permitted by the authorities evaporation is the only remedy. The author has consequently tried this experiment in large vessels and by adding sulphuric acid has quickened the expelling of the sulphurous acid. He obtained a thick, syrup-like mass which after cooling became stone hard and could be broken. For practice on a large scale the evaporating tower of R. Schneider, as represented in fig. 20, would best suit for the purpose of evaporation. But unfortunately the plant is too expensive, as the product of evaporation cannot be used with profit, as in the regeneration of the soda. The residues of evaporation do not even have a higher fertilizing value. These residues of evaporation have been recommended as feed stuff for stock, used either alone or mixed with other feed stuff, but the author has not learned that experiments have led to any practical results.

Dr. Frank, at the conclusion of a lecture already mentioned, is of the opinion that the feed value of the evaporated, or at least concentrated leach is not small, as for instance 16-18 per cent. of sugar are contained therein; but there is no way yet to utilize the leach fitly, besides the transportation of the leach would be too expensive and the evaporation so much more costly. Nothing else is left to do at present but, according to Frank's method, to remove as much as possible the sulphurous acid and eventually, where it can be done, to use the purified leach for the irrigation of meadows and fields, whereby at the same time the difficulty existing with many factories of getting rid of the leach would be removed in the most simple manner. The carbonhydrates, sugar, etc., which in comparison with their high food value have but small fertilizing value, thereby yield little, but the mineral constituents of the

wood, dissolved in the leach, directly benefit the vegetable growth.

One cubic meter of pine wood (quite dry) for instance weighs about 450 kilogram and furnishes 4 to 5 kilos of clean ashes, corresponding to about 20 to 25 kilos ordinary impure wood ashes; consequently to every one who is acquainted with the utmost favorable yield of wood ash fertilizing for feed crops and especially for acid meadows, the advantage of rational irrigation will be clear. The repeatedly mentioned Frank method for purification of the leach, which is combined with the recovery of the sulphuric acid, consists, according to his own statements, of the following: The sulphurous acid brought into the digester with the sulphite leach is only in a small part consumed and chemically changed in the process of cellulose making, while the larger part, about 70 per cent., is separated in the form of monosulphite, part of it escaping in gaseous form, which part of it together with the leach in which it is dissolved, is carried to the water currents. As then the sulphurous acid in gaseous form as well as that conducted away with the leach, can become very troublesome to the neighborhood of the factories and injures not only man, but also plants and animals. By its manifold and sometimes quite trying disadvantages have been caused to the management. Mitscherlich has endeavored to do away with the inconvenience caused by escaping of the sulphurous acid with the vapors, by conducting them into the towers. Owing, however, to the great rapidity with which the vapors enter their absorption in the towers is insufficient, especially during the hot season, and the same can be said of the condensation of the vapors, which is employed by factories not equipped with towers. In regard to the leaches, which, because of their high amount of organic substances are very troublesome in smaller water currents, there has not yet been found a practically useful method to free it from its amount of sulphurous acid and other injurious substances. The evaporation of the leaches, taken up by several factories, has proved to be a very costly make-shift on account of the rapid destruction of the evaporating apparatus, the enormous consumption of coal and the absolute worthlessness of the residues of evaporation as fuel, the more as with the very evaporation the sulphurous acid is carried along into the air.

In his method Dr. Frank endeavors to remove only those constituents of the leach and vapors which are proven to act injuriously. As such, besides the sulphurous acid and its combinations in solution he names the aldehyds contained in the leaches and finally the dissolved resin and tar-like substances, which in later separating becomes injurious to the gill breathers, as to the plants by excluding the air. As Dr. Frank has proved in an expert report the other constituents of the leaches, mostly sugar and amgloides, also the mineral constituents of the woods, are not only entirely harmless and well suited for the nurishing of animals and plants, but also, as far as they are of organic nature, rapidly and completely removed, even in quite small water currents by oxydization.

However, in order not to make the purification of the leaches too expensive Dr. Frank combines this method with the recovery of the sulphurous acid which, together with resins, dye stuffs and nitrogenous constituents he precipitates in the form of the almost insoluble mono-sulphate of lime. Then the liquid freed from its injurious constituents is submitted to a further chemical treatment with air and carbonic acid, whereby besides the oxydation of the aldehyds, also the small amount of monosulphite in solution is transformed into the entirely harmless sulphite of lime (gyps).

The precipitate of sulphite of lime, as obtained is very impure. After settling, according to Dr. Frank's patented method, it is freed from the organic substances and then yields a perfectly pure sulphite of lime, which stirred up with water and charged to Frank's leaching apparatus is worked into a leach perfectly equal to a fresh sulphite solution by simply treating with sulphurous acid.

As a minimum saving, obtained by this method of recovery, Dr. Frank guarantees 33 per cent. of that quantity of sulphur which was necessary for the sulphite solution originally charged to the digester, so that, when 17 kilos of sulphur were necessary per cubic meter of leach without recovery, with his method of recovery this consumption is reduced to two-thirds or about 11 kilos; thus bringing the total cost, per cubic meter sulphite leach down to 33 per cent.

However, as the quantity of sulphurous acid left unchanged in the digesting process, theoretically estimated,

amounts to about 70 per cent., with careful management of the recovery it can be expected to recover from the sulphite leaches up to about 50 per cent. of the sulphurous acid and thus to reduce the supply of sulphur material one-half.

The installation of Frank's method for the purification and recovery of the leaches, in consequence of the expert opinion of the reputed chemists, Professor Dr. Medicus and Professor Dr. Engler has been officially ordered for the cellulose factory in Aschaffenburg, and on account of the entirely satisfactory results obtained the protests and complaints raised against the working of the factory were non-suited in all instances. The factory in Aschaffenburg gives the daily expense of the method as 12 marks, the value of the recovered sulphur material; as 35 marks, the reconsumption of the latter; as 40 per cent., so that besides the removing of the formerly existing difficulties in regard to running off the leaches there is left a daily surplus of 23 marks, amortizing within a short time the cost of the plant. According to the statement of the inventor, there are at present in Germany, Austria and Sweden a large number of factories engaged to install his method and for the new cellstuff plant of the Munkedal, Achtielbolag, Uddevalla, Dr. Frank has even accepted guarantee for the fish stock of the mill creek, separated by a grate.

Dr. Frank's method for the purification of the leach and recovery of the sulphurous acid thus appear to be, for the cellstuff factories as well as for their neighbors an equally benefitting solution of the perplexing question.

A perfect conclusion of the wash water question will, however, not be reached until the utilization of the carbohydrates, so liberally contained in the leaches, for feeding purposes. The composition of the leaches, freed from the sulphurous acid and the resins, according to his investigations, comes near to that of the molasses residues, but against the latter has the advantage of containing more sugar (up to 18 per cent of dry substance) and less salts. The production of aniline, contemplated by some, as well as its employment for the manufacture of alcohol, acetic acid and naphtha, if paying at all, requires a complicated plant, so that for the present it will be well to take in consideration only its agricultural utilization, as feed for the stock, or its use for irrigating and fertilizing fields and

means. The possibility of preparing substances useful in the arts from the material is still left open.

The agricultural utilization left entirely out of the question the method is, however, practical for all those factories which for the present have difficulties on account of running off the leaches, as the leaches freed from their directly injurious constituents and also of proteids give little cause for processes of fermentation and putrefication, as well as for the formation of algae, and even in moderate dilution in small flowing waters suffer rapidly a complete oxydation and self-purification which is prevented or much retarded by the presence of sulphurous acid. Besides the unpurified leaches, containing about 0.6 to 0.75 per cent. of sulphurous acid, according to the experiments of Dr. Weigelt-Rufach, when let into waters used for fish culture, require a dilution, corresponding to about 1,500 times its own volume. For a digester charge of 60 cubic meters, in order to satisfy these demands, 90,000 cubic meters of water must therefore be used, a quantity not everywhere attainable.

In addition to this it may be mentioned that the unpurified wastes certainly favor the formation of algae in the river bed, and that especially with small water currents the disadvantage comes so much more to light as a direct contamination by cellulose fibres can be seen. These algae form principally during the cold season, and disappear almost entirely in summer. If, however, once present, they can scarcely be eliminated even if the supply of leach ceases entirely. The author has observed that five years after the closing of a factory the algae reappear regularly in the bed of the river during winter.

In the soda cellstuff manufacture the waste leaches can also be used for the preparation of stock feed. A Mr. Voigt has taken out a patent for this, No. 33,235, and gives the following as his method: The incrusting constituents of the straw and likewise of the wood (consisting of carbohydrates, proteins, etc.,) received by the animal make up the nutritive part and are completely assimilated by the animal organism and transformed into flesh and fat. The inventor therefore aims to recover in the form of press-cakes these very important, nutritious products, which in cellulose manufacture by means of soda enter into the alkaline leach. After the process of digesting is finished the alka-

line liquid, much admixed with organic matter, is heated with sulphuric acid until neutral, whereby under formation of sulphate of soda (Glauber's salts) all organic matter dissolved in the alkaline liquid (with the exception of some coloring matter) separate in the form of a most finely divided precipitate. This precipitate is then separated from the sodium-sulphate solution by means of a filter press, then once more washed with water and again pressed and so dried in the shape of cake and brought into trade. The

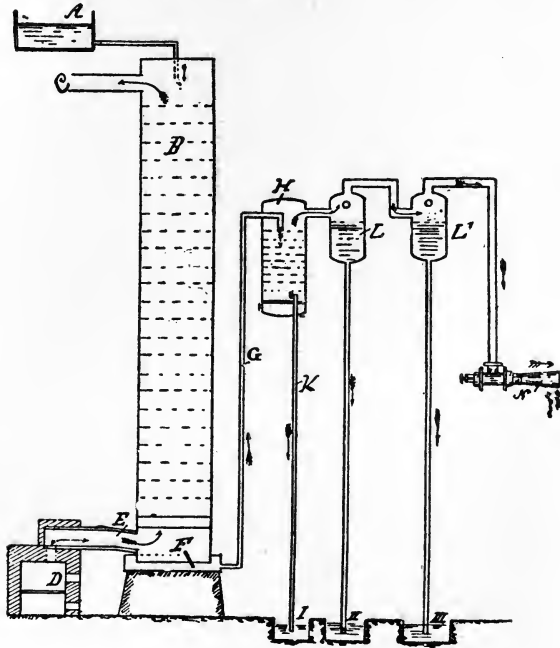

Fig. 106.

product thus obtained is of a pleasant scent and taste, resembling fresh hay and is readily eaten by horses, cows and sheep. On account of its fine division, as well as of its nutritive constituents, it is almost entirely assimilated by the animal organisms, and may take a conspicuous place among the food essences now existing in commerce.

In regard to the so-called mother liquor (sodium sulphate solution) still left it is evaporated in an evaporating

pan to crystalization, and as crystal Glauber salts brought into commerce. According to the view of others the food obtained by Voigt's method is not a food essence in the economical agricultural sense of the word, as it does not contain proteins (albuminates) as these have already been decomposed when boiling the wood with the caustic leach. They admit, however, that the food is useful.

To prevent the injurious effect of the leaches, Alexander Kumpfmiller and E. Schultgen obtained a patent (D. R. P. No. 81,338) on the method described below:

The waste leaches coming from the digesters, from the vessel A, Fig. 106, continuously flow into the tower B, which is filled with a rack of stones and serves to warm the waste leach, and at the same time to cool off the roasting shells. A distributing arrangement causes the leaches to drizzle evenly through the whole cross section of the tower; and they collect in the receptacle F. At the foot of the tower the hot roast gases from the pyrites oven D enter through pipe E into the tower, give off their heat to the leaches drizzling down and, cooled, leave the tower through pipe C, which conducts them to the absorption apparatuses.

By the action of the roast gases on the leaches a reaction takes place between the sulphuric acid contained in the former and the sulphite acid contained in the latter according to the equation:

$$\text{SO}_3 \text{ plus Ca SO}_3 \text{ plus H}_2\text{O equals Ca SO}_4 \text{ plus SO}_2 \text{ plus H}_2\text{O.}$$

Consequently the sulphurous acid combined with lime, contained in the leaches, is liberated, while at the same time the roast gases are freed of sulphuric acid, whereby the formation of gyps crusts in the lower parts of the absorption apparatus is avoided.

From the foot of the tower the hot waste leaches are raised through pipe G into a vacuum apparatus H and as a thickened liquid continuously flows through pipe K into the reservoir J, placed about 10 meters below.

With the spray, evolved under the influence of the vacuum in the spray condenser L, which is fed with lime water, the steam vapors are condensed and the sulphurous acid is absorbed. The water of condensation therefore, after previous cooling, can partially again be used for feed water, partially, as so-called half leach, it can be pumped to the absorption towers.

Two spray condensers can be used; in this case the one L is fed with water for the condensation of the steam vapors, the other L, with lime water, to bind the sulphurous acid, so that the sulphite of lime formed is collected in reservoir III, separately from the water of condensation.

The ejector N serves to produce the vacuum, when starting the plant; it can also be employed to conduct the sulphurous acid gas from escaping from the first condenser immediately into the pipe C.

A new patent for the utilization of leaches has been taken out by the stock company Xylolyse and Dr. Emil Meyer in Berlin (D. R. P. No. 45,951) for a method for the production of liquid products of distillation from cellstuff leaches. It reads as follows: In the production of cellstuff from wood almost one-half of the weight of its dry substance is brought in solution by the leaches. By supplying heat by means of steam coils the waste leach from the soda process can be condensed down to 35° B. The condensed leach is mixed with 40 to 55 parts by weight with charcoal, and then formed in uniform, durable and transportable pieces, permitting further drying in heating chambers, or they may with the original amount of water at once be charged into red-hot retorts, without damaging by sudden cooling off and without losing their form in charring.

The distillation, damping and cooling of the residue charcoal, the collecting of the tar, the gas water and the gases differ in no wise from similar known processes. Only the product of distillation itself differs from that of the ordinary charring of wood in retorts, in so far, as formic acid, acetic acid, etc., do not appear, but only methyl-alcohol, etc., and diverse amine combinations are dissolved in the water of condensation; also a tar of different quality is obtained from this resulting to the management the advantage that instead of copper for the condensers iron can be used and in rectification of the gas water its volatile, valuable products can be obtained by distilling off a small quantity.

If the acid leaches of the sulphite process are intended to be worked in this manner the free acid must first be eliminated. Further because the lime in solution in accumulating would in the end disqualify the coal residue, it is to be recommended to precipitate it as sulphate by add-

ing glauber salts, which can always be recovered.

When distilling the sulphite leaches and also the alkaline leaches of the so-called sulphate cellulose containing sulphide of sodium, besides the acetone and the methyl alcohol, other volatile, sulphuric, ceraptanic and alkylthio-carbonic combinations are formed which are neither completely condensed nor are they made harmless when burned with the resulting gas, with which they are mixed.

Another utilization, or rather recovery of spent sulphite leaches, is done by apparatuses which are built by the Golzern Machine Works.

In the sulphite stuff manufacture a liberal third of the sulphurous acid gets lost, about one-sixth is retained in the leaches and runs off with the washings; and just as much escapes with off-vapors into the atmosphere. In this manner scarcely two-thirds of the sulphurous acid charged to the digester are utilized, and sometimes still less.

To remedy this disadvantage, Director Rudolf Kron, in Golzern, has invented a simple plant for the purpose of the recovery of sulphurous acid contained in waste waters and in the off-vapors. The practical trial also yielded a saving of sulphur 30 to 40 per cent. equal to a price reduction of from 5 to 10 marks per ton of cellstuff. At the same time the present rather general contamination of the atmosphere and of the factory water is prevented.

The Papier Zeitung publishes another method for the purification and utilization of the leaches, resulting from the manufacture of sulphite stuff, by Viggo Beutner Drewson. The method consists in the treatment of the spent leaches with caustic lime, if possible free of carbonic acid, at higher temperature and with the application of pressure.

If the leach used in the sulphite stuff manufacture, which possesses a distinct acid character, is treated with caustic lime at ordinary temperature, it combines with the present sulphurous acid to make lime monosulphite. The leach liquid of now-changed condition has lost the capacity to hold in solution part of the organic substances, which were dissolved in the acid solution, and they are precipitated, together with the lime monosulphite. The process results at boiling temperature in the same manner as at ordinary temperature.

Quite different, however, is the result of the action of the

caustic lime on the sulphite leach, when both are heated together to higher temperature under pressure in a closed vessel, because then the lime is able to decompose the organic combinations dissolved in the spent leach, originating from the incrusting substances of the wood. If, then, the bottom sediment, obtained by treating the spent leach with caustic lime at about 6 atmospheres pressure and treating it with muriatic acid, is filtered off, considerable quantities of sulphurous acid escapes, while at the same time a bottom-sediment of organic substances insoluble in water and acid is left contaminated with sulphate of lime. The light yellow leach, filtered off from the original bottom-sediment, produced by the caustic lime, when evaporated, leaves but a small fraction of the substances contained in the spent leach, because the more readily decomposed sulphur substances as well as the principal amount of the organic, so called incrusting substances, are precipitated. Operating with this process it is therefore possible, with such a cheap material, as given in the caustic lime: (1) To purify the spent leaches, and to dispose of them in a simple and harmless manner; and (2) to produce substances of material importance to the arts.

In practice the present method is carried out as follows:

After the finishing of the digesting process the spent leach is charged under pressure into a closed vessel, provided with a stirrer, in which is contained already the required amount of caustic lime, as much as possible rid of carbonic acid. Because of the immediate neutralization of the acid, this vessel may be of iron. As soon as the spent leach has all been blown over into the vessel, steam is admitted, the stirrer is set in motion, and the temperature is maintained at a certain height corresponding to about 6 atmospheres, until a test indicates that the reaction is finished. As soon as this is the case the contents of the vessel are filtered by a filter press. The light yellow liquid of alkaline reaction running off is, when necessary, treated with carbonic acid by passing over it the products of combustion from a chimney by means of a koerting injector, to neutralize the alkalinity. The filtered off bottom-sediment, consisting of calcium-monosulphite, calcium-sulphate and of the lime combinations of the organic substances formed from the incrusting substances of the wood, is then used in place of limestone or limemilk for preparing the bisulphite leach. In treating

with sulphurous acid there are left indissolved principally the organic combinations which are filtered off in a filter press, while the filtrate is returned for use in boiling wood in the manufacture of sulphite cellstuff, exactly like the ordinary bisulphite leach.

In this manner one-fourth to one-half of the original amount of sulphur is recovered. The organic substances, secured by this method, can be used for different purposes.

For a clear illustration of the correctness of the above-mentioned proposition of Dr. Frank, to use the purified wastes for irrigation, and thus at the same time causing self-improvement of contaminated river water, a case from practice may serve. It is about the contamination of a small creek, in total carrying capacity about one cubic meter of water per minute, by the spent liquors of a sulphite cellulose factory. Dr. Frank had been appointed expert to give his opinion whether the complaints that the water be fit neither for domestic purpose, nor for the irrigation of meadows, were just, and whether a remedy could be had. It is now scientifically proved that water contaminated with organic matter in solution in long contact with air, especially with much fall, is again purified, that consequently in this process the oxygen dissolved in water proves to be more active, than the less active oxygen of the air. But as water in the presence of sulphurous acid cannot contain oxygen, the self-purification of water mixed with larger quantities of sulphite leach would be but insignificant. Nevertheless, even in this unfavorable instance, a decrease of the organic matter with simultaneous oxidation of the sulphurous acid to sulphuric acid can be proved. The following analyses serve as vouchers for this:

Sample 1. The creek water, when entering the factory, contained in one million parts a total residue per liter of 150 mg.; of this: organic matter 78, lime 42, sulphurous acid 0.

Sample 2. Mixture of leach and leach wash-water, when leaving receptacle, contained in one million parts a total residue of 58,450 mg.; of this: organic matter 42,200, lime 5,658, sulphurous acid 1,669.

Sample 3. The creek water, taken 5 kilometers below the factory, contained in one million parts a total residue of 1,600 mg.; of this: organic matter 600, lime 184, sulphurous acid 35.

A further effective purification, scarcely worthy of consideration in currents with abundant water, would be obtained in this case by employing the small creek for irrigation purposes, because the soil, by its absorbing and oxidizing influence, not only diminishes the organic matter, but also the amount of lime. In this irrigation also the most valuable mineral constituents of the wood, potash, etc., would do good service.

To test the behavior of purified leaches by experiment, part of the spent leach (Sample 2) was freed from sulphurous acid and resins, according to Dr. Frank's method. Although after this operation the liquid appeared somewhat darker than the acid leach, after diluting with thirty times its amount of water, and longer contact with air, it proved to contain one-half less of organic matter than Sample 3, and also the color was lighter, after adding water. But much more distinctly did the success of the purification appear by this, that, while Sample 3 notwithstanding its high amount of sulphurous acid, inside of two days appeared very turbid; the sample made of purified leach with equal dilution kept perfectly clear for 8 to 10 days under the same conditions. It was still less difficult to prove by figures and by experiments on a large scale that the recovery of the sulphurous acid connected with the purification of the spent leaches, besides covering all expense, yielded a considerable surplus.

From these experiments it seems: That the waste-waters in question, after they are freed from sulphurous acid and resinous particles, do not in any manner harm the vegetation, but are especially suited for the irrigation of meadows and fields, because they contain numerous valuable fertilizing substances. Also that the purified waste-waters admitted to the river are not injurious to fish and warm-blooded animals, and are useful for many domestic purposes, as numberless spring waters, serving to supply cities, show a higher amount of lime than the creek water of Sample 3.

Then, although larger river currents are at the disposition of most cellulose factories, to receive their wastes, the extreme case here cited proves that only the directly injurious constituents need to be removed from the waste-waters of the sulphite leach, while for the removing of the organic matter in solution, sugar, amyloids, etc., in themselves quite harmless, the energetic self-purification in the river can be counted upon with confidence.

Some instructions by the government, which have already proven successful, are the following:

The spent leachs, or spent leaches and washings together, are to be treated with caustic lime, so that they are rendered almost, but not quite, neutral. The last remnant of acid is to be removed by gradual treatment with limestone, while admitting air.

To regulate the latter process, impenetrable collecting ponds are to be built, which will hold fourteen times the amount of the daily produced quantity of spent leach and from which it can be run off at the upper edge.

Drawing off may be done when thorough neutrality of the liquid has ensued, but only into water currents, which cause a dilution five hundred times the off-run.

Another cause for the contamination of the water in cellulose factories is by the pyrites residues stored away in heaps. During heavy rains they are leached out, and the water running off, like the other not purified waste-waters, acts injuriously and must therefore be conducted off in such a way that, together with the other waste-waters, it can be purified or dropped. The residues themselves make a very good material for roads; because they make such hard roads and do not permit any vegetation to come out.

When the pyrites residues are heaped up near a river, great damage can be easily done when, during a flood, the residues are carried off over fields and meadows, and thus great surfaces can for years at least be made partially sterile.

In the neighborhood of cellulose factories complaints are general about contamination of the air. With the sulphite cellulose factories, especially if no residences are nearby, the evil is not so very bad, as the annoying smell is present only when the necessary care is not taken.

The soda cellulose factories have greater difficulties to combat in this respect. When discharging the digester, and in the process of recovering the soda, gases escape which may be compared to the odor of foul cabbage, and which sometimes appear so strongly that the whole country for a great distance, according to strength and direction of the wind, is made to suffer. Notwithstanding the fact that the gases frequently evolved in evaporating the leaches are conducted over fires, and there consumed, the extremely suffocating smell can scarcely be avoided, especially as some manufacturers are not able even to tell exactly where the principal stench really comes from.

In consequence of the undeniable harm done the neighborhood, in many countries the authorities were prompted to proceed against the cellulose factories in regard to contamination of the atmosphere, and indeed at some places this was done in such a manner that the very existence of the factories was jeopardized. This appeared most strikingly in the case of the Koeslin cellulose factory, situated 1,500 meters distant from the city, and where the government on account of the suffocating vapors for every special instance imposed a fine (eventually six days' imprisonment of the manager.) In several instances this fine was also collected, although counter-suits were instituted, lasting for years, and although everything was done to diminish the nuisance to the smallest possible measure.

The many complaints about contamination have now caused the authorities to impose severe conditions for the management of cellulose works. For example, the following for a soda cellulose plant:

First—The manufacturer has to adhere to the method of manufacture as described by him in all its parts, especially must all operations of digesting, washing and evaporating be conducted in perfectly closed systems.

Second—All parts of apparatuses (new and old digesters, blow-off cylinders, pipe-lines, etc.), in which are contained liquids heated or treated under pressure, must be made perfectly tight. At the least untightness noticeable the respective part of the apparatus is at once to be cut out and repaired, and not to be put in use again until answering the test described by law (certificate of the boiler inspection.)

Third—Inside of twenty-four hours not more than eight charges shall be emptied. In order to control this limit of production the respective book of changes must at any time be accessible to the representative of the government.

Fourth—The conducting of the leaches, from the digesters as well as from the blow-off cylinders to the end-leach receiver, and from there to the closed condensers, must all through be done in closed pipes.

Fifth—The end-leach receiver itself must also be hermetically closed against the outer air; and the place for the air to enter when blowing off the leach must be provided with an automatic valve opening inside.

Sixth—The vapors produced in the digester must be blown off continuously and by a surface condenser with water cool-

ing and sufficiently large condensing surface must be conducted to two receptacles, in which the separation of condensed oil and water goes on. The dimensions of these receptacles must be such that a complete separation of the oil takes place, before emptying. This oil must be carried off in well-closed vessels and provision must be made that in separating the water it does not come in contact with the outer air. The gases not condensed in the coolers must be conducted in closed pipes to a fire, and there be entirely consumed. From the reservoirs the water left after removing the condensed oil is to be pumped into an apparatus in which by a heating coil the last traces of the volatile oils and odors are expelled, and also burned in a grate fire.

Seventh—The vapors leaving the second condenser, if still containing uncondensed gases, cannot be used to heat the leach mixture, but must be condensed by themselves, and the uncondensable part, as under sixth, must be burned in a grate fire.

Eighth—All hitherto mentioned gas conductors, leading under the grate fires, must end in the form of a spray under the middle of the respective fire grates.

Ninth—The fire-wall, inclosing the ante-room, must be constructed in such manner that it cannot become untight. If untightness should show, no leach shall be evaporated in this ante-room.

Tenth—The gases from the ovens before entering the chimney must be made to pass a final fire, so that all odors left are consumed. If the ordinary grate fire should not fulfill its purpose with sufficient completeness it is to be replaced by a regenerative gas fire with highly heated air.

Eleventh—The lyes prepared for digesting should not contain more than 10 per cent. sulphide of sodium of the amount of soda (caustic soda and carbonate of soda figured on the latter) in the leach.

Twelfth—The observation of all permit conditions, the maximum amount of sodium sulphide of the leaches, as well as the question of retaining and consuming of the odorous gases, is placed under chemical and technical supervision.

Thirteenth—The wash-waters, yielded in washing out the leaches adhering to the digested wood stuff in the blow-off cylinder, must, before being admitted to the river, be mixed with the spent liquors of the chlorine-bleach.

The changes made in the soda factory in question con-

sist of the following: The wood is not boiled to a finish with the same leach, but the leach is gradually circulated in the digesters, being in four different states, so that finally the stuff comes in contact with pure leach. The digesters are no longer blown out into the open, but into closed vessels, and there thoroughly washed out.

Thereby less but more concentrated leaches are obtained for the calcining process; and, further, the opening of the digesters, filled with hot stuff which was part of the cause of the complaint of the neighborhood, is entirely avoided. The complete combustion of the gases produced in calcining is also aimed at by the calcining oven containing three equally divided fireplaces, so that at the end of the oven all gases must again pass a powerful fire, worked with strong supply of air. Of the products of combustion of this pro-

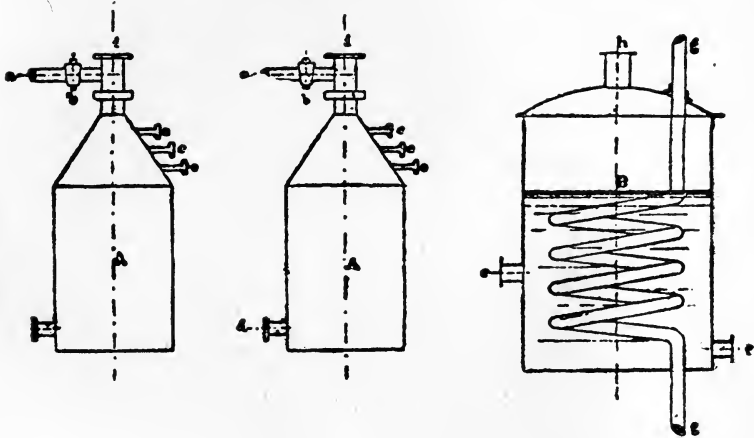

Fig. 107.

cess more than 50 analyses were made in different parts of the oven, and of the chimney at the different states of work, and at different times, because it has been apprehended that hydrogen sulphite could be produced by the dry distillation of sulphide of sodium formed from the sulphate of soda. This presumption, however, has not been confirmed; sulphide of hydrogen was not formed at all by the analyses, or in such small quantities as found in the products of combustion of every larger coal fire. It could, consequently, not be settled

that the employment of sulphate of soda with the arrangements made would cause any additional inconveniences.

The arrangements as prescribed for rendering harmless the water of condensation originating from blowing-off the digester are illustrated in the sketch (Fig. 107) and for its explanation the following is to be said: After the vapors produced when blowing off the over-pressure of the digesters have been conducted through a condenser, the waters of condensation and the uncondensed vapors are alternately passed through the pipes *a a* by means of valves *b b* to the closed iron reservoirs *A A*. In these accumulates the water, while the uncondensed vapors are through the pipes *i i* conducted under a fire, where they are consumed with a bluish flame.

While the one reservoir *A* is filling the other is standing still for 5 to 6 hours; during which time the oily substances separate on top. The latter are then let off by the outlets *c c c* provided with valves, and burned in a fire. The liquids cleared off in the reservoirs, which always contain odorous substances, are, through the pipe connections *d d* and *e* pumped to the closed iron vessels *B* and heated by the steam coils *g g*. The last traces of the odorous substances are here volatilized and through *h* reach a fire, where they are also burned up. The spent water, freed from its odorous substances in the vessel *B*, after it has gone through a process of precipitation and clarifying with caustic lime, is let off through *f* and re-employed in the factory.

For the sulphite cellstuff factories, after hearing several experts, more severe instructions were issued by some authorities, for which the following points may serve as an example. These were made for the Aschaffenburg paper factory previous to the erection of a sulphite cellulose plant:

First—The extensions of the factory plant must be executed exactly according to the plans submitted and under compliance with the instructions of the general building regulations.

Second—For the additional steam boiler a permit of the Bavarian Association for steam boiler revision must be deposited in regard to its safety, as well as to completeness and tightness of its armature parts.

Third—All arrangements, as far as the chemical department is concerned, must be such that sulphurous vapors cannot escape. Therefore all apparatuses, absorption and di-

gesting apparatuses and all pipe-lines must always be maintained in condition and the draft in the sulphur pans is to be regulated in such manner that sulphurous acid cannot escape.

Fourth—The digester-vapors must not escape into the open air when blowing off the boiler, but must be conducted partially through pipe-lines which can be shut off partially by putting in injectors; they have to be conducted into freshly charged digesters.

Fifth—The purification and carrying off of the waste-waters must be done separately from those of the soda cell stuff factory. The diluted spent leaches, before admitting to the Aschaff, must be submitted to Dr. Frank's method of purification, whereas the water coming from the rest of the plant, especially from the wash-hollander, must by means of a special pipe-line, be conducted to the clearing basins, arranged in the soda cell stuff plant.

Sixth—The number of basins to be put up for purification and clearing of the washed spent leaches is set down at three, with a cubic contents of 60 cubic meters each and a bottom face of about 309 square meters. They have to be put up in such manner that side walls and bottom, in proportion to the pressure of the liquid, are sufficiently strong and made watertight, laid with cement mortar, and besides are lined inside with a layer of cement to obtain perfect impenetrableness.

Seventh—The precipitates obtained in the purification of the waste-waters, according to Dr. Frank's method, if not utilized as fertilizers, must after drying in the air again be burned.

Eighth—The letting off of the waste-water from the clarifying basin must be regulated in such manner that not more than 1.5 liter per second are admitted to the Aschaff.

Ninth—The circular saws employed in the plant, and all parts of the transmission, as gearing, pulleys, etc., as far as in the reach of the workmen, must be provided with sufficient means of protection.

PLANNING OF CELLULOSE FACTORIES.

From a consideration of the different processes of cellulose manufacture as treated in the previous chapters and considering the difficulties and aggravations by adjacent property-holders and the authorities, it will be plain that when newly

planning a cellulose factory the utmost importance must be paid to the right selection of the place. As in cellulose manufacturing there is not a large consumption of power, and the steam engines to-day are built so that the consumption of coal is reduced to a minimum, it is not necessary to look for cheap water-power, but rather for the immediate neighborhood of a large river, which facilitates the direct supply of wood or part of it by water, and may also permit the shipping of the finished product, but principally facilitates the disposition of the waste-waters.

If possible the lot should not be situated above a city, and not too near a large community, or especially valuable plantations, or parks. When the supply of wood is not possible directly by the river, it is most necessary to be near a railroad and to possess a track if possible right into the with every cellulose factory. In the rarest cases, a factory will be so situated that it may get its whole supply of wood nearby, i. e., carting it directly from the woods. Almost always the factories are dependent on the supply from greater distances, and it is well, if besides the high railroad freights, the cost of carting from and to the depot has not to be added. It must be considered that every cellulose factory, for instance, figured for but one Mitscherlich digester, for a yearly production of 9,000,000 liters of dry cellulose, about 7,000 volumeters of wood are necessary, which at its mean amount of dryness, alone represents a weight of 3,680,000 kilograms. When considering the other materials necessary for the above amount of wood per year, the following statement is obtained:

Materials.	Kilo- meters.
Wood (7,000 volumeters).....	3,680,000
Cellulose: Dry, 900,000, moist.....	1,800,000
Pyrites	530,000
Lime	180,000
Coal	1,200,000
Other materials	110,000
	<hr/>
Total	7,500,000

From this statement it will be seen that for 100 kg. air-dry cellulose about 58 per cent. of pyrites are used. It is to be remarked, however, that factories with larger plants use

but 50 per cent., or only 45 per cent. of pyrites, according to quality and other circumstances. When employing pure sulphur, which is better in many instances, the consumption is much less. Herrmann Brungger, according to his experiences, states the consumption of 99 per cent. of sulphur, as 9.77 kg. for 100 kg. of air-dry cellstuff.

Therefore, for every single digester at least 7,500,000 kilos of material have to be carried to and from the factory each year, which, even with favorable situation of the factory, gives a high expense for freight; especially as in recent years the manufacturer cannot evade the request of the customers to deliver the cellulose free. Favorable means of communication must therefore also be considered of first importance, when selecting the place. It would consequently not be economy to select a lot perhaps cheap and otherwise suitable but lying off the roads.

Another important condition is abundance of pure water. If the purity is not satisfactory, or at times turbulence is caused by rain, etc., there from the very beginning, the planning of large clearing ponds or other arrangements must be cared for. Care must be taken that the clearing arrangement or wells are above the plant, in regard to the direction of the river, so that a contamination by the waste-waters partially sinking into the soil is excluded.

When the lot is not level but somewhat hilly, this can be used with advantage by putting the pyrite-ovens and the towers so high that the leach can be conducted through a pipe-line directly into the digesters from the leach tanks, whereby a leach pump becomes unnecessary. By the higher situation of the towers sulphurous acid escaping on top enters the high layers of the air and thus, before falling down, is more diluted and made harmless.

It would not be of much value to go here beyond the general rules for planning a cellulose factory, and perhaps to show for example in sketch one or several existing plants, as every new plant must suit the local conditions and also the instructions of the local authorities. Besides, in every plan the projected size of the planned establishment and means of the proprietor must be taken into consideration, and above all the system, according to which the cellulose is to be made. To execute the plan of a new establishment in every single instance a technical expert must certainly assist.

From the standpoint of the paper manufacturers must

next be viewed the two large groups of the soda and sulphite-cellulose, which, because in the manufacture of paper, they are intended to take the place of the rags, partially or entirely, he likes in general to compare with the cotton and linen fibre because, at least in its qualities, they do in fact show much similarity to them. Both linen and cotton fibres are employed with equal importance, but often one can by no means be substituted for the other; where very particular qualities of a paper are in question. As a rule, however, the greater value must be acknowledged to the linen fibre. The same with the two celluloses mentioned: the soda cellulose is generally softer, more similar to cotton, finding employment for many purposes, however the sulphite-cellulose has, in a measure, displaced it because it is unconditionally firmer, some sorts can be bleached better and besides it is on the average sold somewhat cheaper.

The cause of the difference not only of the two principal groups, but also of the celluloses of the different sulphite processes compared with each other, can be perceived from the comparison on the next page, which, while not quite complete, shows however, that the pressure and the temperature at which the fibre has been boiled, is of great influence.

From this can be learned that especially the soda-cellulose is produced with very high pressure, high temperature, but in proportion short duration of boiling; that the sulphite-celluloses are, on the average, worked with low pressure, low temperature and shorter time of boiling, and that especially in the manufacture of Mitscherlich cellulose the lowest temperature, the lowest pressure, but the longest time for boiling are employed. According to the last-mentioned method boiling is consequently the most carefully done, i. e., it is evident that in slowly removing the incrusting constituents, employing but the most necessary degrees of heat, the proper fibre must be spared most, the produced cellulose must consequently possess the greatest firmness. And such is indeed the case.

The author, when a paper manufacturer, had for a long time worked in most of the different sorts of cellulose and received his supply of Mitscherlich cellulose from different factories; but in regard to firmness this product has not yet been surpassed by any other system.

When comparing soda-cellulose with the cotton fibre, the Mitscherlich cellulose must be put in place of the toughest linen and hemp fibre and accordingly the other principal sul-

METHOD.		Highest pressure of steam in atmosphere.	Highest temperature in degrees Celsius.	Duration of boiling in hours.	Leach.
Soda	Amerika	6-8	160°-172°	6	12° B
	Dahl	5-10		30-40	6°-14° B
	Ungerer	6-8			5°-6° B
Sulphite	Pictet & Brilas	5-7	90°-105°	10	7° SO ₂
	Ettman	6		8	5° B
	Flodquist	4,7		9	
	Archbold	4-5		1½	
	Partington	4		12-14	
	Trancke	3,5		12-17	
	Ritter-Kellner	4-5		16-36	
Mischerlich	3	117-120°	35-38	5°-7° B	

phite processes, Ritter-Kellner, Graham and Fladquist would represent the finer fibres of linen. The comparison is also fitting in reality, because it cannot be denied that the Mitscherlich cellulose, with all its advantages, has however the disadvantages, to be somewhat less pure, for which reason, when bleached, it cannot well be employed for the finer sorts of paper, while the cellulose according to Ritter-Kellner and a few other related processes great firmness is combined with great purity, and in the first qualities by glaring whiteness, so that it can be used with advantage for the best papers. Lately Mitscherlich cellulose is also produced bleached very white and faultlessly pure.

(The End.)



Geyer's Directory

of the

A M E R I C A N P A P E R T R A D E P u b l i s h e d A a n n u a l l y

is the most complete, desirable and compact directory of the Mills ever published.

All Mills of one owner grouped together.

Information all in one place.

The Directory also contains list of Mills arranged by States.

Selected list of all trades allied with the paper industry.

Every Paper Dealer, Stationer and Lithographer needs a copy for Reference.

P R I C E \$2.00.

Andrew Geyer

PUBLISHER

318 Broadway = New York

WATER MARKS

AND

TRADE MARKS

As • Applied • to • Paper

This popular little help and money-saver for the trade is in universal use among all handlers of paper. The cost is so low and the size so handy that everybody can afford to have one in his pocket, or in the pigeon hole of the desk.

THERE ARE SOME 4000 TITLES IN THE BOOK. SIZE 4 1-2 X 6 INCHES, AND IN TWO STYLES OF BINDING.

Paper Cover - - - 35c.
Cloth Back Linen Board Sides, 50c.

Cash to accompany all orders.

ANDREW GEYER

PUBLISHER

318 Broadway • • New York

Cheney Bigelow Wire Works

Manufacturers of

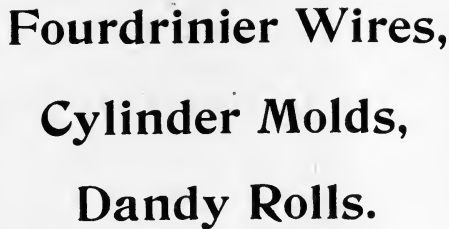

**Fourdrinier Wires,
Cylinder Molds,
Dandy Rolls.**

Brass, Copper and Iron Wire Cloth.

OFFICE RAILINGS,
WINDOW GUARDS,
Elevator Cabs and Enclosures.

SPRINGFIELD, MASS.

Established 1842. Incorporated 1887.



FOR PAPER AND PULP MILL USES
AND ALL CLASSES OF DRIVING.

Rosendale... Reddaway Belting & Hose Co.
NEWARK, NEW JERSEY.

Manufacturers 

CAMEL HAIR BELTING "Camel" Brand.
STITCHED COTTON BELTING "Sphinx" Brand.
LINEN FIRE HOSE.

Try Our Camel Hair Belt, OIL FINISH.
Jackson Patent Joints are the Best for all kinds of Belting.

NEVIN IRON WORKS,
LOWVILLE, N. Y.

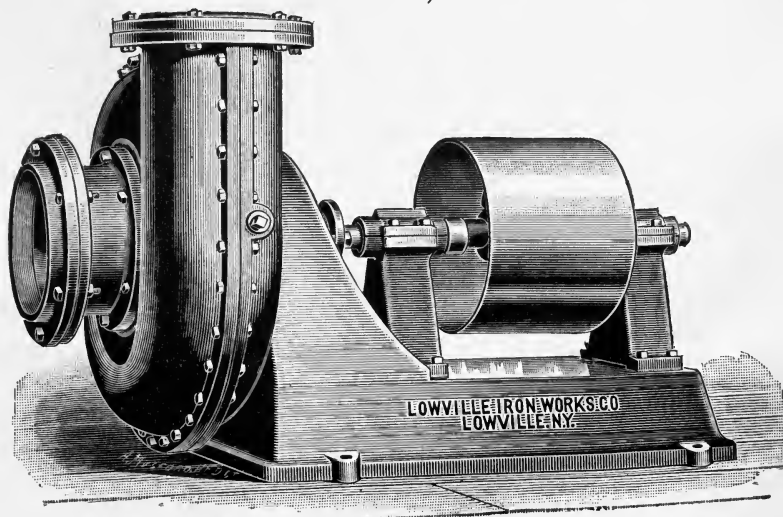

Manufacturers of PUMPS and WOOD PULP MACHINERY.

THIS BOOK IS DUE ON THE LAST DATE
STAMPED BELOW

AN INITIAL FINE OF 25 CENTS
WILL BE ASSESSED FOR FAILURE TO RETURN
THIS BOOK ON THE DATE DUE. THE PENALTY
WILL INCREASE TO 50 CENTS ON THE FOURTH
DAY AND TO \$1.00 ON THE SEVENTH DAY
OVERDUE.

SEP 14 1936

APR 14 1937

SEP 8 1937

SEP 8 1937

OCT 21 1937

MAY 15 1943

FEB 5 1947

15 Apr 5 1947
6 Apr 5 1947

Holyoke Machine Co.

ALL KINDS OF

Calenders Paper Mills

Glazed Paper & Board Manufacturers

Dusters Turbine Wheels

TS 1145
S 38

102018

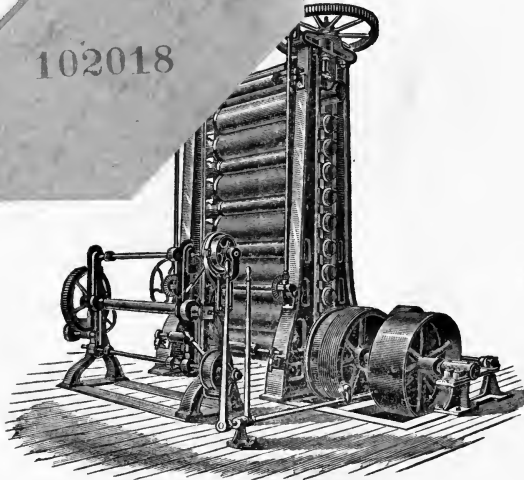

CHILLED IRON ROLLS, PUMPS

COTTON ROLLS

HUSK ROLLS

PAPER ROLLS

HYDRAULIC PRESSES

WOOD PULP MACHINERY

HOLYOKE, MASS., U.S.A.

