

ornia
al

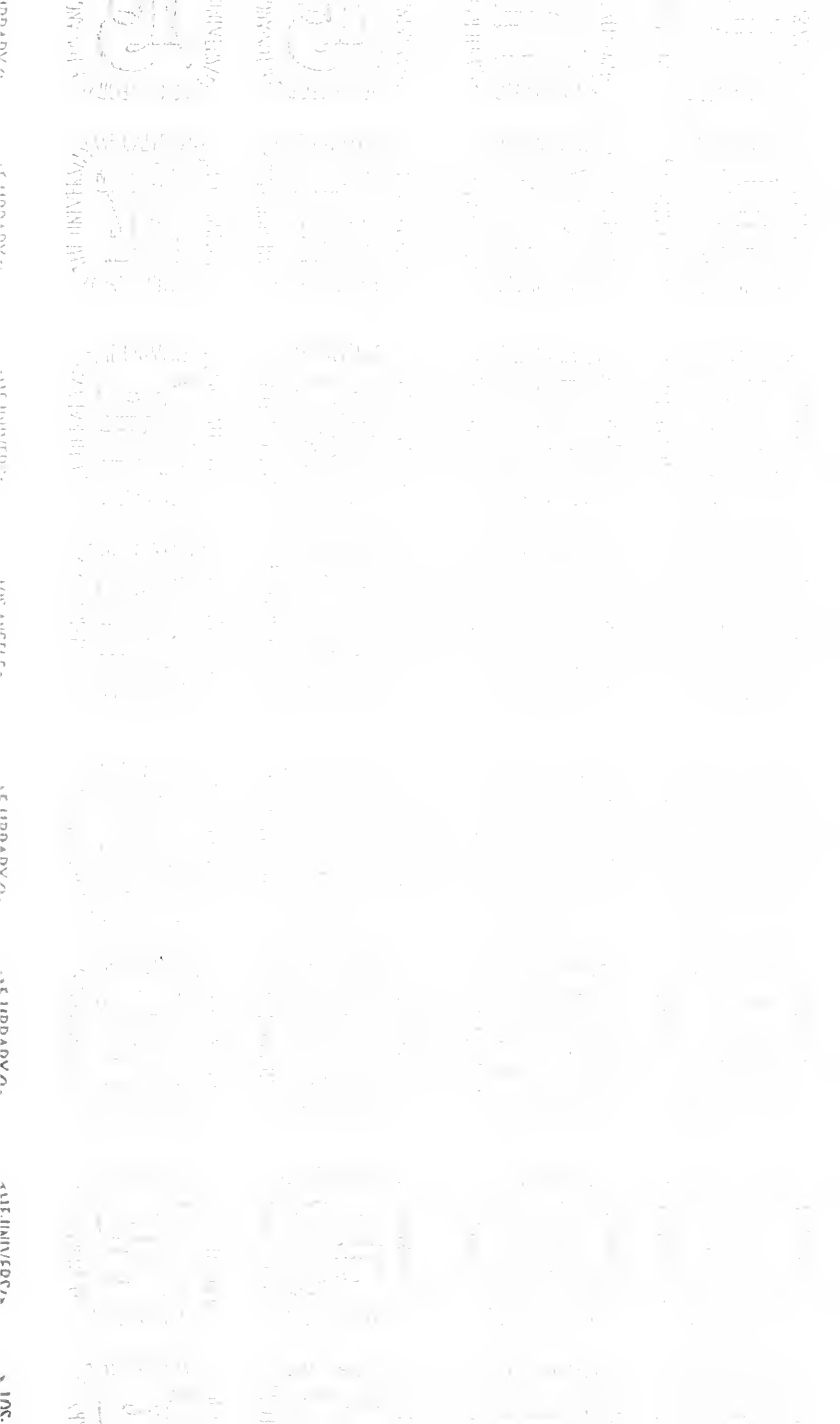



Illustrated & Copied by the University of Aberdeen.

M E C H A N I C S;

O R, T H E

D O C T R I N E

O F

M O T I O N.



C O M P R E H E N D I N G,

- I. The general LAWS of MOTION.
- II. The DESCENT of BODIES perpendicularly, and down inclined PLANES, and also in CURVE SURFACES. The MOTION of PENDULUMS.
- III. CENTERS of GRAVITY. The EQUILIBRIUM of BEAMS of TIMBER, and their FORCES and DIRECTIONS.
- IV. The MECHANICAL POWERS.
- V. The comparative STRENGTH of TIMBER, and its STRESS. The POWERS of ENGINES, their MOTION, and FRICTION.
- VI. HYDROSTATICS and PNEUMATICS.

*Da veniam scriptis, quorum non gloria nobis
causa, sed utilitas officiumque, fuit.*

OVID DE PONTO III.

L O N D O N :

Printed for J. N O U R S E, in the Strand;
Bookfeller in Ordinary to his MAJESTY.

M D C C L X I X.

T H E

P R E F A C E.

HAVING some years since written a large book of Mechanics, which is sold by Mess^{rs}. Robinson, and Co. in Pater-noster-Row. I have here given a short abstract of that book, as it falls properly into this course; and especially as that branch of science, is of such extensive use in the affairs of human life. I do not in the least, design this to interfere with the other book, being rather an introduction to it, as it explains several things in it more at large; particularly in the first section, as being of universal extent and use; and likewise in several other parts of the book, especially such as have been objected to by ignorant writers. I have also added several things not mentioned in the other book, which are more simple and easy, and more proper for learners. So that this short treatise may be looked upon as an introduction to the other book, and will doubtless facilitate the reading of it. As to the higher and more difficult matters, as few care to trouble their heads about them, I have said little of them here, being not so proper for an introduction. To mention one or two things; I had taken a great deal of pains to find out the true form of a bridge, that shall be the strongest, and of a ship that shall sail the fastest; both upon principles that I know to be as certain and demonstrative as the Elements of Euclid; both these you have in the other book. But, as we have no occasion in England, for

lute motion. But when compared with others in motion, it is called *relative motion*.

7. *Direction* of motion is the course or way the body tends, or the line it moves in.

8. *Quantity* of motion, is the motion a body has, considered both in regard to its velocity and quantity of matter. This is also called the *Momentum* of a body.

9. *Vis inertiae*, is the innate force of matter, by which it resists any change, striving to preserve its present state of rest or motion.

10. *Gravity* is that force wherewith a body endeavours to fall downwards. It is called *absolute gravity* in empty space; and *relative gravity* when immersed in a fluid.

11. *Specific gravity*, is the greater or lesser weight of bodies of the same magnitude, or the proportion between their weights. This proceeds from the natural density of bodies

12. *Center of gravity*, is a certain point of a body; upon which, the body when suspended, will rest in any position.

13. *Center of motion*, is a fixed point about which a body moves. And the *axis of motion* is a fixed line it moves about.

14. *Power* and *weight*, when opposed to one another, signify the body that moves another, and the other which is moved. The body which begins and communicates motion is the *power*; and that which receives the motion, is the *weight*.

15. *Equilibrium* is the balance of two or more forces, so as to remain at rest.

16. *Machine* or *Engine*, is any instrument to move bodies, made of levers, wheels, pullies, &c.

17. *Mechanic powers*, are the ballance, lever, wheel, pulley, screw and wedge.

18. *Stress* is the effect any force has to break a beam, or any other body; and *strength* is the resistance

P O S T U L A T A.

3

resistance it is able to make against any straining force.

19. *Friction* is the resistance which a machine suffers, by the parts rubbing against one another.

P O S T U L A T A.

1. That a small part of the surface of the earth may be looked upon as a plane. For tho' the earth be round, yet such a small part of it as we have any occasion to consider, does not sensibly differ from a plane.

2. That heavy bodies descend in lines parallel to one another. For tho' they all tend to a point which is the center of the earth, yet that center is at such a distance that these lines differ insensibly from parallel lines.

3. The same body is of the same weight in all places on or near the earth's surface. For the difference is not sensible in the several places we can go to.

4. Tho' all matter is rough, and all engines imperfect; yet for the ease of calculation, we must suppose all planes perfectly even; all bodies perfectly smooth; and all bodies and machines to move without friction or resistance; all lines straight and inflexible, without weight or thickness; cords extremely pliable, and so on.

A X I O M S.

1. Every body endeavours to remain in its present state, whether it be at rest, or moving uniformly in a right line.

2. The alteration of motion by any external force is always proportional to that force, and in direction of the right line in which the force acts.

3. Action and re-action, between any two bodies, are equal and contrary.

B 2

4. The

4. The motion of any body is made up of the sum of the motions of all the parts.

5. The weights of all bodies in the same place, are proportional to the quantities of matter they contain, without any regard to their figure.

6. The vis inertiae of any body, is proportional to the quantity of matter.

7. Every body will descend to the lowest place it can get to.

8. Whatever sustains a heavy body, bears all the weight of it.

9. Two equal forces acting against one another in contrary directions; destroy one another's effects. And unequal forces act only with the difference of them.

10. When a body is kept in equilibrio; the contrary forces in any line of direction are equal.

11. If a certain force generate any motion; an equal force acting in a contrary direction, will destroy as much motion in the same time.

12. If a body be acted on by any power in a given direction. It is all one in what point of that line of direction, the power is applied.

13. If a body is drawn by a rope, all the parts of the rope are equally stretched. And the force in any part acts in direction of that part. And it is the same thing whether the rope is drawn out at length, or goes over several pullics.

14. If several forces at one end of a lever, act against several forces at the other end; the lever acts and is acted on in direction of its length.

S E C T. I.

The General Laws of MOTION.

P R O P. I.

*T*HE quantities of matter in all bodies, are in the compound ratio of their magnitudes and densities.

For (Def. 3.) in bodies of the same magnitudes, the quantities of matter will be as the densities. Increase the magnitude in any ratio, and the quantity of matter is increased in the same ratio. Consequently the quantity of matter is in the compound ratio of the density and magnitude.

Cor. 1. *In two similar bodies, the quantities of matter are as the densities, and cubes of the diameters.*

For the magnitudes of bodies are as the cubes of the diameters.

Cor. 2. *The quantities of matter are as the magnitudes and specific gravities.*

For (by Def. 3. and 11.) the densities of bodies are as their specific gravities.

P R O P. II.

The quantities of motion in all moving bodies, are in the compound ratio of the quantities of matter and the velocities.

For if the velocities be equal, the quantities of motion will manifestly be as the quantities of matter. Increase the velocity in any ratio, and the quantity of motion will be increased in the same ratio.

6 GENERAL LAWS

ratio. Therefore it follows universally, that the quantities of motion are in the compound ratio of the velocities and quantities of matter.

Cor. Hence if the body be the same, the motion is as the velocity. And if the velocity be the same, the motion is as the body or quantity of matter.

P R O P. III.

In all bodies moving uniformly, the spaces described, are in the compound ratio of the velocities and the times of their description.

For in any moving body, the greater the velocity, the greater is the space described; that is, the space will be as the velocity. And in twice or thrice the time, &c. the space will be twice or thrice as great; that is, the space will be increased in proportion to the time. Therefore universally the space is in the compound ratio of the velocity, and the time of description.

Cor. 1. *The time of describing any space, is as the space directly and velocity reciprocally; or as the space divided by the velocity. And if the velocity be the same, the time is as the space. And if the space be the same, the time is reciprocally as the velocity.*

Cor. 2. *The velocity of a moving body, is as the space directly, and time reciprocally; or as the space divided by the time. And if the time be the same, the velocity is as the space described. And if the space be the same, the velocity is reciprocally as the time of description.*

P R O P.

P R O P. IV.

The motion generated by any momentary force, or by a single impulse, is as the force that generates it.

For if any force generates any quantity of motion; double the force will produce double the motion; and treble the force, treble the motion, and so on. If a body striking another, gives it any motion, twice that body striking the same, with the same velocity, will give it twice the motion, and so the motion generated in the other will be as the force of percussion.

Cor. 1. *Hence the forces are in the compound ratio of the velocities and quantities of matter.*

For (Prop. II.) the motions are as the quantities of matter multiplied by the velocities.

Cor. 2. *The velocity generated, is as the force directly, and quantity of matter reciprocally. Therefore if the bodies are equal, the velocities are as the forces. And if the forces are equal, the velocities are reciprocally as the bodies.*

Cor. 3. *The quantity of matter, is as the force directly, and velocity reciprocally. And therefore if the velocities be equal, the bodies are as the forces. And if the forces be equal, the bodies are reciprocally as the velocities.*

P R O P. V.

The quantity of motion generated, by a constant and uniform force, is in the compound ratio of the force and time of acting.

For the motion generated in any given time will be proportional to the force that generates it;

and in twice that time, the motion will be double by the same force; and in thrice that time it will be treble; and so every part of time adds a new quantity of motion equal to the first; and therefore the whole motion, will be as the force, and the whole time of acting.

Cor. 1. *The motion lost in any time, is in the compound ratio of the force and time.*

Cor. 2. *The velocity generated (or destroyed) in any time, is as the force and time directly, and quantity of matter reciprocally. The same is true of the increase or decrease of velocity.*

For the motion, that is (Prop. II.) the body multiplied by the velocity, is as the force and time. And therefore the velocity is as the force and time directly, and the body reciprocally.

Cor. 3. *Hence if the force be as the quantity of matter, the velocity is as the time. Or if the force and quantity of matter be given, the velocity is as the time.*

And if the time and quantity of matter be given, the velocity is as the force.

And if the force and time be given, the velocity is reciprocally as the matter.

Cor. 4. *The time is as the quantity of matter and velocity directly, and the force reciprocally. Therefore,*

If the force and velocity be given, the time is as the quantity of matter.

If the quantity of matter and velocity be given, the time is reciprocally as the force.

Cor. 5. *The force is as the quantity of matter and velocity directly, and the time reciprocally. Whence,*

If the velocity is at the time, or if the velocity and time be given, then the force is as the quantity of matter.

And

And if the velocity and quantity of matter be given, the force is reciprocally as the time.

Cor. 6. *The quantity of matter is as the force and time directly, and the velocity reciprocally. Therefore, if the force and time be given, the quantity of matter is reciprocally as the velocity.*

Cor. 7. *Hence also if the body be given, the velocity is in the compound ratio of the force and time.*

And if the force be given, the time is in the compound ratio of the matter and velocity, or as the quantity of motion.

P R O P. VI.

If a given body is urged by a constant and uniform force; the space described by the body from the beginning of the motion, will be as the force and square of the time.

Suppose the time divided into an infinite number of equal parts or moments. Then in each of these moments of time, the space described (Prop. III. Cor. 2.) will be as the velocity gained; that is, (by Cor. 7. Prop. V.) as the force and time from the beginning. And the sum of all the spaces, or the whole space described, will be as the force and the sum of all the moments of time from the beginning. Therefore put $t =$ the whole time, and the whole space described will be as the force and sum of the times 1, 2, 3, 4, &c. to t . But the sum of the arithmetic progression $1 + 2 + 3 + 4$

... to $t = \frac{t + 1}{2} \times t = \frac{1}{2} tt$, because t is infinite

or consists of an infinite number of moments. Therefore the whole space described will be as the force and $\frac{1}{2} tt$; that is, (because $\frac{1}{2}$ is a given quantity), as the force and the square of the time of description.

Cor.

Cor. 1. *If a body is impelled by a constant and uniform force; the space described from the beginning of the motion, is as the velocity gained, and the time of moving.*

For the space is as the force and square of the time, or as the force \times time \times time. But (Cor. 7. Prop. V.) the force \times time is as the velocity; therefore the space which is as the force \times time \times time, is as the velocity \times time.

Cor. 2. *If a body urged by any constant and uniform force, describes any space; it will describe twice that space in the same time, by the velocity acquired.*

For the sum of all the spaces described by that force, $1 + 2 + 3$ &c. to t , was shewn to be $\frac{1}{2}tt$. But the sum of all the spaces described by the last velocity, will be $t + t + t$ &c. to t terms, whose sum is tt . But tt is double to $\frac{1}{2}tt$; that is, the space described by the last velocity, is double the space described by the accelerating force.

Cor. 3. *Universally in all bodies urged by any constant and uniform forces; the space described is as the force and square of the time directly, and the quantity of matter reciprocally.*

For (Cor. 1.) the space is as the time and velocity. But (Prop. V. Cor. 2.) the velocity is universally as the force and time directly, and quantity of matter reciprocally. Therefore the space is as the square of the time and the force directly, and matter reciprocally; whence,

Cor. 4. *The product of the force, and square of the time, is as the product of the body and space described.*

Cor. 5. *The product of the force and time, is as the product of the quantity of matter and velocity.*

For (Prop. V.) the product of the force and
time,

time, is as the motion; that is, as the body and Fig. velocity.

Cor. 6. *The product of the body, and square of the velocity, is as the product of the force and the space described.*

For (Cor. 5.) the product of the body and velocity, is as the force and time. Therefore, the body \times velocity square, is as the force \times time \times velocity; but time \times velocity is as the space (by Prop. III.); therefore body \times velocity square is as the force \times space.

SCHOLIUM.

If any quantity or quantities are given, they must be left out. And such quantities as are proportional to each other must be left out. For example, if the quantity of matter be always the same; then (Cor. 3.) the space described is as the force and square of the time. And if the matter be proportional to the force, as all bodies are in respect to their gravity; then (Cor. 6.) the space described is as the square of the velocity. Or if the space described be always proportional to the body; then (Cor. 6.) the force is as the square of the velocity. Again, if the body be given, then (Cor. 4.) the space is as the force and square of the time. And if both the quantity of matter and the force be given, the space described is as the square of the time. And so of others.

P R O P. VII.

If ABCD be a parallelogram; and if a body at A, be acted upon separately by two forces, in the directions AB and AC, which would cause the body to be carried thro' the spaces AB, AC in the same time. Then both forces acting at once, will cause the body to be carried thro' the diagonal AD of the parallelogram.

Let the line AC be supposed to move parallel to itself;

Fig. itself; whilst the body at the same time moves
 1. from A, along the line AC or *bg*, and comes to *d* at the same instant, that AC comes to *bg*. Then since the lines AB, AC, are described in the same time; and *Ab*, *Ad*, are also described in the same time. Therefore, as the motions are uniform, it will be, $Ab : bd :: AB : BD$; and therefore *AdD* is a straight line, coinciding with the diagonal of the parallelogram.

Cor. 1. *The three forces in the directions AB, AC, AD, are respectively as the lines AB, AC, AD.*

Cor. 2. *Any single force AD denoted by the diagonal of a parallelogram, is equivalent to two forces denoted by the sides AB, AC.*

Cor. 3. *And therefore any single force AD may be resolved into two forces, an infinite number of ways, by drawing any two lines AB, BD, for their quantities and directions.*

SCHOLIUM.

This practice of finding two forces equivalent to one, or dividing one force into two; is called the *composition and resolution* of forces.

PROP. VIII.

2. *If three forces A, B, C, keep one another in equilibrium; they will be proportional to three sides of a triangle, drawn parallel to their several directions, DI, CI, CD.*

Produce AD to I, and BD to H, and complete the parallelogram DICH; then (Prop. VII.) the force in direction DC, is equal to the forces DH, DI, in the directions DH, DI. Take away the force DC and putting the forces DH, DI equal thereto;

thereto; and the equilibrium will still remain. Fig. 2.
Therefore (Ax. 10.) DI is equal to the force A opposite to it; and DH or CI equal to its opposite force B. And as CD represents the force C, the three forces A, B, and C will be to one another as DI, CI, and CD.

Cor. 1. Hence if three forces acting against one another, keep each other in equilibrio; these forces will be respectively as the three sides of a triangle drawn perpendicular to their lines of direction; or making any given angle with them, on the same side.

For this triangle will be similar to a triangle whose sides are parallel to the lines of direction.

Cor. 2. If three active forces A, B, C keep one another in equilibrio; they will be respectively as the sines of the angles, which their lines of direction pass through.

For A, B, C are as DI, CI, CD; that is, as S.DCI, S.CDI, and S.DIC. But S.DCI = S.CDH = S.CDB. And S.CDI = S.CDA. Also S.DIC = S.BDI = S.BDA.

Cor. 3. If ever so many forces acting against one another, are kept in equilibrio, by these actions; they may be all reduced to two equal and opposite ones.

For any two forces may, by composition, be reduced to one force acting in the same plane. And this last force, and any other, may likewise be reduced to one force acting in the plane of these; and so on, till they all be reduced at last to the action of two equal and opposite ones.

P R O P. IX.

If a body impinges or acts against any plain surface; it exerts its force in a line perpendicular to that surface. 3.

Let the body A moving in direction AB, with a given velocity, impinge on the smooth plain FG at the

Fig. the point B. Draw AC parallel, and BC perpendicular to FG; and let AB represent the force of the moving body. The force AB is, by the resolution of forces, equivalent to AC and CB. The force AC is parallel to the plain, and therefore has no effect upon it; and therefore the surface FG is only acted upon by the force CB, in a direction perpendicular to the surface FG.

Cor. 1. *If a body impinges upon another body with a given velocity; the quantity of the stroke is as the sine of the angle of incidence.*

For the absolute force is AB, and the force acting on the surface FG is CB. But $AB : CB :: \text{rad} : \text{S.CAB}$ or ABF.

Cor. 2. *If an elastic body A impinges upon a hard or elastic plane FG; the angle of reflexion will be equal to the angle of incidence.*

For if AD be parallel to FG; the motion of A in direction AD parallel to the plane, is not at all changed by the stroke. And by the elasticity of one or both bodies, the body A is reflected back to AD in the same time it moved from A to B; let it pass to D; then will $AC = CD$, being described in equal times; consequently the angle $ABC = \text{angle } CBD$; and therefore the angle $DBG = \text{angle } ABF$.

Cor. 3. *If a non-elastic body strikes another non-elastic body; it loses but half the motion, that it would lose, if the bodies were elastic.*

For non-elastic bodies only stop, without receding from one another; but elastic bodies recede with the same velocity.

PROP. X.

The sum of the motions of two or more bodies, in any direction towards the same part, cannot be changed by any action of the bodies upon each other.

Here I reckon progressive motions affirmative; and regressive ones negative, and to be deducted out of the rest to get the sum.

1. If two bodies move the same way; since action and re-action are equal and contrary, what one body gains the other loses; and the sum remains the same as before. And the case is the same, if there were more bodies.

2. If bodies strike one another obliquely; they will act on one another in a line perpendicular to the surface acted on. And therefore by the law of action and re-action there is no change made in that direction.

3. And in a direction parallel to the striking surface, there is no action of the bodies, therefore the motion remains the same in that direction. Whence the motions will remain the same in any one line of direction.

Cor. 1. *Motion can neither be increased nor decreased, considered in any one direction; but must remain invariably the same for ever.*

This follows plainly from this Prop. for what motion is gained to one (by addition), is lost to another body (by subtraction); and so the total sum remains the same as before.

SCHOLIUM.

This Prop. does not include or meddle with such motions as are estimated in all directions. For upon this supposition, motion may be increased or decreased

Fig. decreased an infinite number of ways. For example, if two equal and non-elastic bodies, with equal velocities, meet one another; both their motions are destroyed by the stroke. Here at the beginning of the motion, they had both of them a certain quantity of motion, but to be taken in contrary directions; but after the stroke they had none.

P R O P. XI.

The motion of bodies included in a given space, is the same, whether that space stands still; or moves uniformly in a right line.

For if a body be moving in a right line, and any force be equally impressed both upon the body and the line it moves in; this will make no alteration in the motion of the body along the right line. And for the same reason, the motions of any number of bodies in their several directions will still remain the same; and their motions among themselves will continue the same, whether the including space is at rest, or moves uniformly forward. And since the motions of the bodies among themselves; that is, their relative motions remain the same, whether the space including them be at rest, or has any uniform motion. Therefore their mutual actions upon one another, must also remain the same in both cases.

S E C T. II.

The perpendicular descent of heavy bodies, their descent upon inclined Planes, and in Curve Surfaces. The Motion of Pendulums.

P R O P. XII.

TH E velocities of bodies, falling freely by their own weight, are as the times of their falling from rest.

For since the force of gravity is the same in all places near the earth's surface (by Post. 3.), and this is the force by which bodies descend. Therefore the falling body is urged by a force which acts constantly and equally; and therefore (by Cor. 3. Prop. V.) the velocity generated in the falling body in any time, is as the time of falling.

Cor. 1. *If a body be thrown directly upwards with the same velocity it falls with; it will lose all its motion in the same time.*

For the same active force will destroy as much motion in any time, as it can generate in the same time.

Cor. 2. *Bodies descending or ascending gain or lose equal velocities in equal times.*

P R O P. XIII.

In bodies falling freely by their own weight; the spaces described in falling from rest, are as the squares of the times of falling.

For since gravity is supposed to be the same in all places near the earth. Therefore the falling
C
body

Fig. body will be acted on by a force which is constantly the same; and therefore (by Prop. VI.) the spaces described, from the beginning of the motion, or since their falling from rest, will be as the squares of the times of falling.

Cor. 1. *The spaces described by falling bodies are as the squares of the velocities.*

For (Prop. XII.) the velocities are as the times of falling.

Cor. 2. *The spaces described by falling bodies, are in the compound ratio of the times, and the velocities acquired by falling.*

Cor. 3. *If a body falls through any space, and move afterwards with the velocity gained in falling; it will describe twice that space in the time of its falling.*

Cor. 4. *A body projected upward with the velocity it gained in falling, will ascend to the same height it fell from.*

SCHOLIUM.

All these things would be true if it was not for the resistance of the air, which will retard their motion a little. In very swift motions, the resistance of the air has a very great effect in destroying the motions of bodies.

P R O P. XIV.

4. *If a heavy body W be sustained upon an inclined plane AC, by a power F acting in direction WF parallel to the plane; and if AB be parallel to the horizon and BC perp. to it. Then if the length AC denotes the weight of the body, the height CB will denote the power at F which sustains it, and the base AB the pressure against the plane.*

Draw BD perpendicular to AC, then CB will be the direction of gravity, DC parallel to WF will be

be the direction of the force at F, and DB the direction of the pressure (by Prop. IX). Therefore (by Prop. VIII.) the weight of the body, the power at F, and the pressure; will be respectively as BC, CD and DB. But the triangles ABC, BDC are similar, and therefore BC, CD and DB are respectively as AC, CB and BA. Therefore the weight, power and pressure, are as the lines AC, CB and AB.

Cor. 1. *The weight of the body, the power F that sustains it on the plane, and the pressure against the plane; are respectively as radius, the sine and cosine of the planes elevation above the horizon.*

For AC, CB and AB are to one another, as radius; sine of CAB, and sine of ACB.

Cor. 2. *The power that urges a body W down the inclined plane is = $\frac{CB}{AC} \times$ weight of W. Hence,*

Cor. 3. *If a prismatic body whose length is AC lie upon the inclined plane AC; it is urged down the plane with a force equal to the weight of the prism of the length CB.*

Cor. 4. *If there be two planes of the same height, and two bodies be laid on them proportional to the lengths of these planes; the tendency down the planes will be equal in both bodies.*

P R O P. XV.

If AC be an inclined plane, AB the horizon, BC perp. to AB. And if W be a heavy body up n the plane, which is kept there by the power P acting in direction WP. Draw BDE perp. to WP. Then the weight W, the power P, the pressure against the plane; will be respectively as AB, DB and AD.

For AB being a horizontal plane is perpendicular to the action of gravity; and BD is perp. to

Fig. the direction of the power P ; and AD is the
 5. plane, which is perp. to the direction of the pressure against that plane. Therefore (Cor. 1. Prop. VIII.) the weight of the body, the power P , and the pressure; are as AB , BD and AD . And if the direction of the power WP be under the plane, the proportion will be the same, as long as BD is perpendicular to WP .

Cor. 1. *The weight of the body W , is to the power P that sustains it :: as cosine of the angle of traction CWP : to the sine of the plane's elevation CAB .*

For the weight : power :: $AB : BD :: S.ADB$ or $WDE : S.BAD :: \text{cos. } DWE$ or $CWP : S.BAC$, where the angle CWP made by the plane and direction of the power is called the angle of Traction.

Cor. 2. *Hence it is the same thing as to the power and weight, whether the line of direction is above or below the plane, provided the angle of traction be the same. For an equal power will sustain the weight in both cases.*

Cor. 3. *The weight of the body : is to the pressure against the plane :: as the cosine of the angle of traction CWP : to the cosine of BNP , the direction of the power above the horizon.*

For the weight W : pressure :: $AB : AD :: S.ADB : S.ABD :: S.ADE :: S.NBE :: \text{cos. } EWD$ or $PWC : \text{cos. } BNP$.

Cor. 4. *Hence the pressure against the plane is greater when the direction of the power is below the plane, the weight remaining the same.*

SCHOLIUM.

Altho' the power has the same proportion to the weight, when the angle of traction is the same; whether the direction of the power be above or
 below

below the plane. Yet, since the pressure upon the plane is greater, when the line of direction is below the plane. Therefore in practice, when a weight is to be drawn up hill, if it is to be done by a power whose direction is below the plane, the greater pressure in this case will make the carriage sink deeper into the earth, &c. and for that reason will require a greater power to draw it up, than when the line of direction is above the plane.

Fig. 5.

P R O P. XVI.

If a weight W upon an inclined plane AC, be in equilibrio with another weight P hanging freely; then if they be set a moving, their perpendicular velocities in that place, will be reciprocally as their quantities of matter. 6.

Take WA a very small line upon the plane AC; draw AB parallel to the horizon, and BC perp. to it. Draw AF, and WR, BE perpendicular to it; and WT, DV perp. to AB. Let W descend thro' the small line WA upon the plane, then P will ascend a height equal to AR perpendicularly; and WT will be the perpendicular descent of W. The triangles AWR and ADE are similar; and likewise the triangles AWT and ADV. Therefore $WT : DV :: AW :: WD :: WR : DE$. And alternately, $WT : WR :: DV : DE$; and $WR : AR :: DE : AE$; therefore $WT : AR :: DV : AE ::$ (by the similar triangles DBV and AEB) $DB : AB ::$ (Prop. XV.) $\text{power } P : \text{weight } W$.

Cor. 1. *If any two bodies be in equilibrio upon two inclined planes; their perpendicular velocities will be reciprocally as the bodies.*

Cor. 2. *If two bodies sustain each other in equilibrio, on any planes; the product of one body \times by its*

Fig. *perp. velocity, is equal to the product of the other body \times by its perp. velocity.*

P R O P. XVII.

7. *If a heavy body runs down an inclined plane CA; the velocity it acquires in any time, moving from rest; is to the velocity acquired by a body falling perpendicularly in the same time; as the height of the plane CB, to its length CA.*

The force by which a body endeavours to descend on an inclined plane, is to its weight or the force of gravity; as CB to CA (by Prop. XIV.). And as these forces always remain the same, therefore (Cor. 2. Prop. V.) the velocities generated will be as these forces, and the times of acting, directly; and the bodies reciprocally. And since the times of acting, and the bodies are the same in both cases, the velocities generated will be as these forces; that is, as the height of the plane CB. to its length CA.

Cor. 1. *The velocity acquired by a body running down an inclined plane, is as the time of its moving from rest.*

Cor. 2. *If a body is thrown up an inclined plane, with the velocity it acquired in descending; it will lose all its motion in the same time.*

P R O P. XVIII.

7. *If a heavy body descends down an inclined plane CA; the space it describes from the beginning of the motion, is to the space described by a body falling perpendicularly in the same time; as the height of the plane CB, to its length CA.*

For the force urging the body down the plane is to the force of its gravity, as CB to CA (by Prop. XIV.),

XIV.), which forces remain constantly the same. Fig. 7.
 And since (Prop. XVII.) the velocities generated in equal times on the plane, and in the perpendicular, are constantly as CB to CA ; the small particles of space described with these velocities, in all the infinitely small portions of time, will still be in the same ratio; and therefore the sums of all these small spaces, or the whole spaces described from the beginning, will be in the same constant ratio of CB to CA .

Cor. 1. *The space described by a body falling down an inclined plane, in a given time, is as the sine of the plane's elevation.*

For if CB be given, and also the perp. descent; that space will be reciprocally as CA , or directly as $S.CAB$.

Cor. 2. *The spaces described by a body descending from rest, down an inclined plane, are as the squares of the times.*

Cor. 3. *If BD be drawn perp. to the plane CA ; then in the time a body falls perpendicularly thro' the height CB , another body will descend thro' the space CD upon the plane.*

For by similar triangles $CA : CB :: CB : CD$.

P R O P. XIX.

If AC is an inclined plane, the time of a body's descending thro' the plane CA , is to the time of falling perpendicularly thro' the height of the plane CB , as the length of the plane CA to the height CB . 7.

For if BD is perp. to CA , then (Cor. 2. Prop. XVIII.) space $CD : \text{space } CA :: \text{square of the time in } CD : \text{square of the time in } CA :: \text{that is, as the square of the time of descending perpendi-$

Fig. 7. cularly in CB (Cor. 3. last) : square of the time in CA. But $CD : CA :: CB^2 : CA^2$. Therefore $CB^2 : CA^2$: square of the time in CB : square of the time in CA. And $CB : CA ::$ time in CB : time in CA.

Cor. 1. *If a body be thrown upwards on the plane with the velocity acquired in descending; it will in an equal time ascend to the same hight.*

Cor. 2 *The times wherein different planes, of the same hight, are passed over; are as the lengths of the planes.*

Let the planes be CA, CF. Then time in AC : time in CB :: CA : CB. And the time in CB : time in CF :: CB : CF. Therefore *ex equo*, time in AC : time in CF :: CA : CF.

P R O P. XX,

8. *If a body falls down an inclined plane, it acquires the same velocity as a body falling perpendicularly thro' the hight of the plane.*

Let the body run down the plane CA whose hight is CB. Draw DF parallel to AB, and infinitely near it. Then the velocities in DA and FB, may be looked upon as uniform. Now (Prop. XIX.) the times of describing CA and CB, will be as CA and CB. Likewise the times of describing CD and CF, will be as CD and CF; that is, as CA and CB. And by division, the difference of the times, or the times of describing DA and FB, will also be as CA and CB; that is, as DA and FB. But (from Prop. III.) the velocities are equal when the spaces are as the times of description. Therefore velocity at A is equal to the velocity at B.

Cor.

Cor. 1. *The velocities acquired, by bodies descending on any planes, from the same height to the same horizontal line, are equal.* Fig. 8.

Cor. 2. *If the velocities be equal at any two equal altitudes D, F; they will be equal at all other equal altitudes A, B.*

Cor. 3. *Hence also, if several bodies be moving in different directions, thro' any space contained between two parallel planes; and be acted on by any force, which is equal at equal distances from either plane. Then if their velocities be equal at entering that space; they will also be equal at emerging out of it.*

For dividing that space into infinitely small parts by parallel planes. Then the force between any two planes may be supposed uniform; and supposing DF, AB to represent two of these planes, then (by Cor. 2.) the velocities at D and F being equal; the velocities at A and B will be equal; that is, the velocities at entering the first part of space being equal, the velocities at emerging out of it, or at entering the second space will be equal. And for the same reason the velocities at entering the second space being equal, those at emerging out of it into the third, will be equal. And consequently the velocities at entering into, and emerging out of the third, fourth, fifth, &c. to the last will be equal respectively.

P R O P. XXI.

If a body falls from the same height, thro' any number of contiguous planes AB, BC, CD; it will at last gain the same velocity as a body falling perpendicularly from the same height. 9.

Let FH be a horizontal line, FD perp. to it. Produce the planes BC, DC to G and H. Then (Cor.

Fig. (Cor. 1. Prop. XX.) the velocity at B is the same
 9. whether the body descend thro' AB or GB. And
 therefore the velocity at C will be the same, whe-
 ther the body descends thro' AEC or thro' GC,
 and this is the same as if it had descended thro'
 HC. And consequently it will have the same ve-
 locity at D, in descending thro' the planes ABCD,
 as in descending thro' the plane HD; that is,
 (Prop. XX.) as it has in descending thro' the per-
 pendicular FD.

Cor. 1. Hence a body descending along any curve surface, will acquire the same velocity, as if it fell perpendicularly thro' the same hight.

For let the number of planes be increased, and their length diminished ad infinitum, and then ABCD will become a curve. And the velocity acquired by descending thro' these infinite planes; that is, thro' the curve ABCD, will be the same as in falling perpendicularly thro' FD.

Cor. 2. If a body descends in a curve, and another descends perpendicularly from the same hight. Their velocities will be equal at all equal altitudes.

Cor. 3. If a body, after its descent in a curve, should be directed upwards with the velocity it had gained; it will ascend to the same hight from which it fell.

For since gravity acts with the same force whether the body ascends or descends, it will destroy the velocity in the ascent, in the same time it did generate it in the descent.

Cor. 4. The velocity of a body descending in any curve, is as the square root of the hight fallen from.

For it is the same as in falling perpendicularly; and in falling perpendicularly, it is as the square root of the hight.

Cor.

Cor. 5. *If a body, in moving thro' any space ED, Fig. 9. be acted on uniformly by any force; its velocity at emerging out of it at D, will be equal to the square root of the sum of the squares of the velocity at E in entering of it, and of the velocity acquired in falling from rest thro' that space ED. And this holds whether the body moves perpendicularly or obliquely.*

For let the body enter the space ED at E, with the velocity acquired in falling thro' FE. Then (Prop. XIII. Cor. 1.) the square of the velocity at E will be as FE; and the square of the velocity at D, as FD; and the square of the velocity at D falling from E, will be as ED. But $FD = FE + ED$; therefore the square of the velocity at D (falling thro' FD) = square of the velocity at E + square of the velocity at D (falling thro' ED). And (Cor. 1. of this Prop.) the velocity will be the same whether the body descends perpendicularly or obliquely.

P R O P. XXII.

The times of bodies descending thro' two similar parts of similar curves, placed alike, are as the square roots of their lengths. 10.

Let ABCD and *abcd* be two similar curves, and suppose BC and *bc* to be infinitely small, and similar to the whole; that is, so that $BC : bc :: AB : ab$. Draw FA parallel to the horizon, and HB, *bb* perp. to it. Then if two bodies descend from A and *a* (Cor. 4. Prop. XXI.) the velocities at B and *b* will be as \sqrt{HB} and \sqrt{bb} ; that is, as \sqrt{AB} and \sqrt{ab} , because AB, *ab* are similar parts. Therefore (Prop. III. Cor. 1.) the times of describing BC and *bc*, are as $\frac{BC}{\sqrt{AB}}$ and $\frac{bc}{\sqrt{ab}}$; that is,

Fig. 10. as $\frac{AB}{\sqrt{AB}}$ and $\frac{ab}{\sqrt{ab}}$ or as \sqrt{AB} and \sqrt{ab} ; that is, as \sqrt{AD} and \sqrt{ad} , because the curves are similarly divided in B and b. After the same manner the times of describing any other two similar parts as BC, bc, will be as \sqrt{AD} and \sqrt{ad} . Therefore by composition the times of describing all the BC's, and all the bc's will be as \sqrt{AD} and \sqrt{ad} . That is, the time of describing the curve AD to the time of describing the curve ad, is as \sqrt{AD} to \sqrt{ad} .

Cor. If two bodies descend thro' two similar curves ABD, and abd; the axes of the curves FD, Fd are as the squares of the times of their descending.

For $\sqrt{FD} : \sqrt{Fd} :: \sqrt{AD} : \sqrt{ad} ::$ time of descending thro' ABD : time of descending thro' abd. And FD, Fd, are as the squares of the times.

P R O P. XXIII.

11: A body will descend thro' any chord of a circle, in the same time that another descends perpendicularly thro' the diameter,

Draw the diameter AB perpendicular to the horizon, and the cords CA, CB. Then since BC is perpendicular to AC, therefore (Prop. XVIII. Cor. 3.) the time of descending thro' the cord AC is equal to the time of falling thro' AB.

Draw CD parallel to AB, and DB parallel to CA, then is CD equal to AB. And by reason of the parallels, the angle DBC = angle BCA = a right angle. Then since DB is perp. to CB, therefore (Cor. 3. Prop. XVIII.) a body will descend thro' the inclined plane CB, in the same time that another falls thro' CD, or which is the same thing, thro' its equal AB.

Cor.

Cor. 1. Hence the times of descending thro' all the Fig. cords of a circle drawn from A or B, are equal 11. among themselves.

Cor. 2. The velocity gained by falling thro' the cord CB, is as its length CB.

For the velocity gained in falling thro' CB is the same as is gained by falling thro' EB; and that velocity is to the velocity gained by falling thro' AB, as \sqrt{BE} to \sqrt{AB} (by Cor. 1. Prop. XIII.); that is, as BC to BA. Therefore if the given velocity in falling down AB be represented by AB. The velocity gained in falling down CB will be represented by CB; and so that in any other cord, by its length.

P R O P. XXIV.

If a pendulum vibrates in the small arch of a cir- 12. cle; the time of one vibration, is to the time of a body's falling perpendicularly thro' half the length of the pendulum; as the circumference of a circle, to the diameter.

If a pendulum suspended by a thread, &c. be made to vibrate in any curve; it is the same thing as if it descended down a smooth polished body made in the form of that curve. For the motions, velocities, and times of moving will be the same in both.

Let OD or OE be the pendulum vibrating in the arch ADC, whose radius is OD. Let OD be perp. to the horizon, and take the arch Ee infinitely small, and draw ABC, EFG, efg, perp. to OD; and draw the cord AD. About BD describe the semicircle BGD. Draw er and Gs perp. to EG.

Put t = time of descending thro' the diameter zOD, or thro' the cord AD. Then the velocities gained

Fig. 12. gained by falling thro' $2OD$, and by the pendulum's descending thro' the arch AE , will be as $\sqrt{2OD}$ and \sqrt{BF} . And the space described in the time t , after the fall thro' $2OD$, is $4OD$. But the times are as the spaces, divided by the velocities. Therefore, $\frac{4OD}{\sqrt{2OD}}$ or $2\sqrt{2OD} : t$ (time of

$$\text{its description) : : } \frac{Ee}{\sqrt{BF}} : \text{time of describing } Ee = \frac{t \times Ee}{2\sqrt{2OD} \times BF}.$$

But by the similar triangles OEF , Ecr ; and KGF , Ggs ; we shall have $\frac{EF}{OD} \times Ee = er = Ff = Gs = \frac{FG}{KD} \times Gg$. Whence $Ee = \frac{OD \times FG}{KD \times EF} \times Gg$. Therefore the time of describing $Ee =$

$$\frac{t \times OD \times FG \times Gg}{2KD \times EF \sqrt{BF} \times 2OD} =$$

$$\frac{t \times OD \times \sqrt{BF} \times FD \times Gg}{2KD \sqrt{BF} \times \sqrt{DO} + OF \times FD \times \sqrt{2OD}} =$$

$$\frac{t \times \sqrt{OD} \times Gg}{2KD \times \sqrt{DO} + OF \times \sqrt{2}} = \frac{t \times \sqrt{2OD}}{4KD \times \sqrt{DO} + OF} \times Gg. = \frac{t \times \sqrt{2OD}}{2BD \times \sqrt{2OD} - DF} \times Gg. \text{ But } DF,$$

in its mean quantity for all the arches Gg , is nearly equal to DK . Therefore the time of describing

$$Ee = \frac{t \times \sqrt{2OD}}{2BD \sqrt{2OD} - DK} \times Gg. \text{ Whence the time}$$

$$\text{of describing the arch } AED = \frac{t \times \sqrt{2OD}}{2BD \sqrt{2OD} - DK}$$

$\times BGD$. And the time of describing the whole arch ADC , or the time of one oscillation is =

$t \times$

$\frac{t \times \sqrt{2OD}}{2BD \sqrt{2OD - DK}} \times 2BGD$. But when the arch

ADC is exceeding small, DK vanishes, and then the time of oscillation in a very small arch is =

$\frac{t \times \sqrt{2OD}}{2BD \sqrt{2OD}} \times 2BGD = \frac{1}{2} t \times \frac{2BGD}{BD}$. But if t

be the time of descending thro' $2OD$, $\frac{1}{2} t$ is the time of descending thro' $\frac{1}{2} OD$. And therefore BD the diameter, is to $2BGD$ the circumference; as the time of falling thro' half the length of the pendulum, to the time of one vibration.

Cor. 1. *In a small arch AED, the time of descending thro' the cord AD, is to the time of descending thro' the arch AED; as the diameter BD, to $\frac{1}{2}$ the circumference.*

For the time of descending thro' the arch AED = $t \times \frac{BGD}{2BD}$; therefore $BD : \frac{1}{2} BGD :: t : \text{time in AED}$.

Cor. 2. *All the vibrations of the same pendulum, in arches not very large, are performed nearly in the same time.*

Cor. 3. *If KD be bisected in L, and T be = time of vibration in a very small arch. Then $T + \frac{KL}{DO + OK} \times T$ will be the time of vibration in any arch ADC, nearly.*

For we found the time of vibration in ADC = $\frac{t \times BGD}{BD} \times \sqrt{\frac{2OD}{2OD - DK}} = T \times \sqrt{\frac{2OD}{OD + OK}}$; and the three lines $DO + OK$, $DO + OL$, and $DO + OD$ are in arithmetical progression; but since KD is very small, they are nearly in geometrical

Fig.
12.

cal progression; whence $\sqrt{\frac{2OD}{DO+OK}} = \frac{DO+OL}{DO+OK}$.

$$\begin{aligned} \text{Therefore the time of vibration} &= T \times \frac{DO+OL}{DO+OK} \\ &= T \times \frac{DO+OK+KL}{DO+OK} = T + T \times \frac{KL}{DO+OK}. \end{aligned}$$

Cor. 4. Hence a falling body will descend thro' a space of 16 feet, and 1 inch, in a second of time.

For by observation, a pendulum 39.13 inches long will swing seconds. And $t \times \frac{BGD}{BD} = 1$ second, and $\frac{BD}{BGD} = t$, or $\frac{2}{3.1416} = \text{time of falling thro' } 2 \times 39.13$. Whence (Prop. XIII.) $\frac{4}{3.1416^2} : 2 \times 39.13 :: 1^2 : \frac{39.13}{2} \times \overline{3.1416^2} = 193.096$ inches = 16.09 feet.

P R O P. XXV.

The lengths of two pendulums, describing similar arches, are as the squares of the times of vibration.

For (Prop. XXII.) the times of descending thro' two similar curves, are as the square roots of the lengths of the curves; that is, as the square roots of the lengths of the pendulum, their centers being alike situated. Therefore the lengths of the pendulums are as the squares of the times of vibrating.

Cor. 1. *The times of vibration of pendulums in small arches of circles, are as the square roots of the lengths of the pendulums.*

For if the arches are similar, the times of vibration are in that proportion. And (Prop. XXIV.

Cor.

Cor. 2.) if the arches are small, tho' not similar, Fig. the vibrations will be the same as before.

Cor. 2. *The velocity of a pendulum at its lowest point, is as the cord of the arch it descends thro'.*

For the velocity at the lowest point is equal to the velocity gained in descending thro' the cord; for they are both of them the same as a body acquires by falling thro' their common altitude. And (Prop. XXIII. Cor. 2.) the velocity gained in falling thro' the cord, is as the length of the cord. Therefore the velocities of a pendulum in different arches, are in the same ratio.

P R O P. XXVI.

Pendulums of the same length vibrate in the same time, whether they be heavier or lighter.

For let the two pendulums P, p, be of the same length; they will each of them fall thro' half the length of the pendulum in the same time. For (Cor. 2. Prop. V.) the velocity generated in any given time, is as the force directly and matter reciprocally. But in the two pendulums, the forces that generate their motions, are their weights, which are as their quantities of matter. Whence we have the velocity of P, to the velocity of p; as $\frac{P}{p}$ to $\frac{p}{P}$, or as 1 to 1; and therefore equal velocities are generated in the same time. Consequently, equal spaces will be described in the same time, and therefore they will fall thro' half the length of one of them in an equal time. And therefore (Prop. XXIV.) their vibrations will be performed in the same time.

Cor. *Hence all bodies whether greater or lesser, heavier or lighter, near the earth's surface will fall*
D thro'.

Fig. thro' equal spaces in equal times; abating the resistance of the air.

Because they are as much retarded by their matter, as accelerated by their weight. The weight and the matter being exactly proportional to one another.

P R O P. XXVII.

The lengths of pendulum's vibrating in the same time, in different places of the world, will be as the forces of gravity.

For (by Prop. V. Cor. 2.) the velocity generated in any time is as the force of gravity directly, and the quantity of matter reciprocally. And the matter being supposed the same in both pendulums, the velocity is as the force of gravity; and the space passed thro' in a given time, will be as the velocity; that is, as the gravity. Therefore if any two spaces be descended thro' in any time, and two pendulums be made, whose lengths are double these spaces; these pendulums (by Prop. XXIV.) will vibrate in equal times; therefore the lengths of the pendulums, being as the spaces fallen thro' in equal times, will be as the forces of gravity.

Cor. 1. *The times wherein pendulums of the same length will vibrate, by different forces of gravity; are reciprocally as the square roots of the forces.*

For (Cor. 2. Prop. V.) when the matter is given, the velocity generated is as the force \times by the time. And (Prop. VI.) the space descended thro' by any force, is as the force and square of the time. Let these spaces be the lengths of the pendulums, then the lengths of the pendulums are as the forces and the squares of the times of falling thro' them. But (Prop. XXIV.) the times of falling thro' them are in a given ratio to the times of vibration; whence

whence the lengths of pendulums are as the forces Fig. and the squares of the times of vibration; therefore when the lengths are given, the forces will be reciprocally as the squares of the times; and the times of vibration reciprocally as the square roots of the forces.

Cor. 2. *The lengths of pendulums in different places, are as the forces of gravity, and the squares of the times of vibration.*

This is proved under Cor. 2. Hence,

Cor. 3. *The times wherein pendulums of any length, perform their oscillations; are as the square roots of their lengths directly, and the square roots of the gravitating forces reciprocally.*

Cor. 4. *The forces of gravity in different places, are as the lengths of pendulums directly, and the squares of the times of vibration reciprocally.*

P R O P. XXVIII. *Prob.*

To find the length of a pendulum, that shall make any number of vibrations in a given time.

Reduce the given time into seconds, then say, as the square of the number of vibrations given : : so the square of this number of seconds : : so is 39.13 : to the length of the pendulum sought, in inches.

Ex. Suppose it makes 50 vibrations in a minute, where a minute is = 60 seconds; then,

As 2500 (the square of 50) : 3600 (the square of 60) : : 39.13 : to the length = $\frac{3600 \times 39.13}{2500}$
 = $\frac{140868}{2500}$ = 56.34 inches, the length required.

Fig. If it be required to find a pendulum that shall vibrate such a number of times in a minute; you need only divide 140868, by the square of the number of vibrations given, and the quotient will be the length of the pendulum.

This practice is deduced from Prop. XXV. for let p be the length of the pendulum, n the number of vibrations, t the time they are to be performed in. Then $39.13 : 1^2 :: p : \frac{p}{39.13} = \text{square}$

of the time of one vibration, and $\sqrt{\frac{p}{39.13}} =$ time of one vibration; then if t be divided by $\sqrt{\frac{p}{39.13}}$ it will give n ; that is, $t \sqrt{\frac{39.13}{p}} = n$, whence $tt \times 39.13 = nnp$, and $nn : tt :: 39.13 : p$.

If the pendulum is a thread with a little ball at it, then the distance between the point of suspension and the center of the ball is esteemed the length of the pendulum. But if the ball be large, say as the distance between the point of suspension, and the center of the ball, is to the radius of the ball; so the radius of the ball to a third proportional. Set $\frac{2}{5}$ of this from the center of the ball downward, gives the center of oscillation. Then the whole distance from the point of suspension to this center of oscillation, is the true length of the pendulum.

13. If the bob of the pendulum be not a whole sphere, but a thin segment of a sphere, as AB, as in most clocks; then to find the center of oscillation, say as the distance between the point of suspension, and the middle of the bob, is to half the breadth of the bob; so half the breadth of the bob, to a third proportional. Set one third of this length from the middle of the bob downwards, gives the center of oscillation. Then the distance
between

between the centers of suspension and oscillation, is Fig. the exact length of the pendulum.

P R O P. XXIX. *Prob.*

Having the length of a pendulum given; to find how many vibrations it shall make, in any given time.

Reduce the time given into seconds, and the pendulum's length into inches; then say, as the given length of the pendulum : to 39.13 :: so is the square of the time given : to the square of the number of vibrations, whose square root is the number sought.

Example. Suppose the length of the pendulum is 56.34 inches, to find how often it will vibrate in a minute.

1 minute = 60 seconds. Then, 56.34 (the length of the pendulum) : 39.13 :: 3600 (the square of 60) : to the square of the number of vibrations = $\frac{3600 \times 39.13}{56.34} = \frac{140868}{56.34} = 2500$, and

$\sqrt{2500} = 50 =$ the number of vibrations sought.

If the time given be a minute, you need only divide 140868 by the length, and extract the root of the quotient for the number of vibrations.

This is the reverse of the last problem, therefore supposing as before in that problem, we have $tt \times 39.13 = nnp$; therefore $p : 39.13 :: tt : nn$.

They that would see a further account of the motions of bodies upon inclined planes, the vibrations of pendulums, and the motion of projectiles; may consult my large book of Mechanics, where they will meet with full satisfaction.

Fig.

S E C T. III.

Of the Center of Gravity ; the equilibrium of beams of timber ; the directions and quantities of the forces necessary to sustain them.

P R O P. XXX.

A body cannot descend or fall downwards, except only when it is in such a position, that by its motion, its center of gravity descends.

14. Let the body A stand upon the horizontal plane BK, and let C be its center of gravity ; draw CD perpendicular to the plane BK. And let the body be suspended at the point C, upon the perpendicular line CD. Then (def 12.) it will remain unmoved upon the line CD. And as CD is perp. to the horizon, it has no inclination to move one way more than another, therefore it will move no way but remain at rest. Take away the line CD, and let the body be supported by the line BC ; if BC be fixed, the body will remain at rest on the line CB. But if CB be movable about B, the body suspended at C, will endeavour to move with its center of gravity downwards along the arch CE, about B as a center, towards N. And for the same reason the body will endeavour to fall the contrary way, moving about the point N ; I say, this will be the case when CD is situated between B and N. But these two motions being contrary to one another, will hinder each other's effects ; and the body will be sustained without falling.

Again,

Again, let the body F be suspended with its center of gravity I upon the perpendicular IH. As this line has no inclination to move to any side, it will therefore remain at rest. Take away the line IH, and let the center of gravity I be suspended on the line IG, then the body will endeavour to descend along the arch IK, for the highest point of the arch is in the perpendicular erected at G. For the same reason if the body be suspended on the line OI, it will endeavour to descend towards K, about the center O; now as both these motions tend the same way, and there is nothing to oppose them; the body must fall towards K. In both these cases it is plain, that when the center of gravity by its motion, descends, the body will fall; but if not, the body will be supported without falling.

Cor. 1. *If a body stands upon a plane, if a line be drawn from the center of gravity perpendicular to the horizon; if this line fall within the base on which the body stands, it will be supported without falling. But if the perpendicular falls without the base, the body will fall.*

For when the perpendicular falls within the base, the body can be moved no manner of way, but the center of gravity will rise. And when the perpendicular falls without the base, towards any side; if the body be moved towards that side, the center of gravity descends; and therefore the body will fall that way.

Cor. 2. *If a perpendicular drawn from the center of gravity perp. to the horizon, fall upon the extremity of the base; the body may stand, but the least force whatever, will cause it to fall that way. And the nearer the perp. is to any side, the easier it will be made to fall, or is sooner thrust over. And the nearer the perp. is to the middle of the base, the firmer the body stands.*

Fig. 14. Cor. 3. *Hence if the center of gravity of a body be supported, the whole body is supported. And the place of the center of gravity must be deemed the place of the body; and is always in a line drawn perpendicular to the horizon, thro' the center of gravity.*

Cor. 4. *Hence all the natural actions of animals may be accounted for from the properties of the center of gravity.*

When a man endeavours to walk, he stretches out his hind leg, and bends the knee of his fore leg, by which means his body is thrust forward, and the center of gravity of his body is moved forward beyond his feet; then to prevent his falling, he immediately takes up his hind foot, and places it forward beyond the center of gravity; then he thrusts himself forward, by his leg which now is the hindmost, till his center of gravity be beyond his fore foot, and then he sets his hind foot forward again; and thus he continues walking as long as he pleases.

In standing, a man having his feet close together cannot stand so firmly, as when they are at some distance; for the greater the base, the firmer the body will stand; therefore a globe is easily moved upon a plane, and a needle cannot stand upon its point, any otherwise than by sticking it into the plane.

When a man is seated in a chair, he cannot rise till he thrusts his body forward, and draws his feet backward, till the center of gravity of his body be before his feet; or at least upon them; and to prevent falling forward, he sets one of his feet forward, and then he can stand, or step forward as he pleases.

All other animals walk by the same rules; first setting one foot forward, that way the center of gravity leans, and then another.

In walking up hill, a man bends his body forward, that the center of gravity may lie forward of his feet; and by that means he prevents his falling backwards. Fig.

In carrying a burthen, a man always leans the contrary way that the burthen lies; so that the center of gravity of the whole of his body and the burthen, may fall upon his feet.

A fowl going over an obstacle, thrusts his head forward, by that means moving the center of gravity of his whole body forwards; so that by setting one foot upon the obstacle, he can the more easily get over it.

P R O P. XXXI.

In any two bodies A, B, the common center of gravity C, divides the line joining their centers, into two parts, which are reciprocally as the bodies. AC : BC :: B : A. 15.

Let the line ACB be supposed an inflexible lever; and let the lever and bodies be suspended on the point C. Then let the bodies be made to vibrate about the immovable point C; then will A and B describe two arches of circles about the center C, and these arches will be as the velocities of the bodies, and these arches are also as the radii of the circles AC and BC. Therefore their velocities are as the radii. Whence, velocity of A : velocity of B :: AC : CB :: (by supposition) B : A. Therefore $A \times \text{velocity of } A = B \times \text{velocity of } B$. Whence (Prop. II.) the quantities of motion of the bodies A and B are equal, and (Ax. 9.) therefore they cannot move one another, but must remain at rest; and consequently (def. 12.) C is the center of gravity of A and B.

Cor.

Fig. 15. Cor. 1. *The products of each body multiplied by its distance from the common center of gravity, are equal.*
 $CA \times A = CB \times B.$

Cor. 2. *If a weight be laid upon C, a point of the inflexible lever AB, which is supported at A and B; the pressure at A to the pressure at B, will be as CB to CA.*

For let the bodies A, B, be both placed in C; then (Cor. 3. Prop. XXX.) since it is the same thing whether the bodies be at A and B, or both of them at C, their center of gravity; therefore the pressures at A and B will be the same in both cases. But when they are at A and B, upon the lever ACB, their pressures are A and B, being the same with the weights; therefore when they are both at C, the pressures at A and B will still be A and B. Therefore (Cor. 1.) since it is $CA \times A = CB \times B$; therefore $CA : CB :: B : A ::$ pressure at B; pressure at A.

P R O P. XXXII.

15. *If there be three or more bodies, and if a line be drawn from one body E to the center of gravity of the rest C. Then the center of gravity of all the bodies divides the line CD, in two parts in D, which are reciprocally as the body E to the sum of all the other bodies. $CD : DE :: E : A + B \&c.$*

For suppose AB and CE to be two inflexible lines; and let the body $W = A + B \&c.$ and let W be placed in the center of gravity C. Then by the last Prop. $CD : DE :: E : W$ or $A + B \&c.$

Cor. *The body E \times DE the distance from the common center of gravity, is equal to the sum of the bodies $A + B \&c. \times$ by DC the distance of their center from the common center of gravity.*

P R O P.

P R O P. XXXIII.

If A, B, be two bodies, C their center of gravity. 16.
F any point in the line AB. Then will $FA \times A + FB \times B = FC \times \overline{A + B}$.

For (Cor. 1. Prop. XXXI.) $CA \times A = CB \times B$;
that is, $\overline{FA - FC} \times A = \overline{FC - FB} \times B$; whence,
by transposition $FA \times A + FB \times B = FC \times \overline{A + B}$.

Cor. Hence the bodies A and B have the same force to turn the lever AF about the point F, as if they were both placed in C their center of gravity.

P R O P. XXXIV.

If several bodies A, B, E &c. be placed on an inflexible straight lever; and if D be their common center of gravity; and if F be any point in the line AE, then $FA \times A + FB \times B + FE \times E \&c. = FD \times \overline{A + B + E \&c.}$ 17.

For if $A + B = W$, then $FA \times A + FB \times B + FE \times E = FC \times \overline{A + B} + FE \times E = FC \times W + FE \times E =$ (Prop. XXXIII.) $FD \times \overline{W + E} = FD \times \overline{A + B + E}$, in the three bodies A, B, E. And after the same manner, if there be four bodies, put $W = A + B + E$, and it will be proved the same way, that the sum of all the products, $FA \times A + FB \times B \&c. =$ distance of the common center of gravity \times by all the four. And so on for more bodies.

Cor. The same Prop. will hold good, when the bodies are not in the line AF, but any where in the perpendiculars passing thro' the points A, B, E &c.

P R O P.

PROP. XXXV.

17. *If there be any number of bodies A, B, E, &c. either placed in the line AF, or any way in the perpendiculars passing thro' A, B, E. And if D be the center of gravity of all the bodies; and F be any point in the line AF. Then the distance of the center of gravity* $FD = \frac{FA \times A + FB \times B + FE \times E}{A + B + E}$.

For whether the bodies be in the points A, B, E, or in the perpendiculars, it will be (by Prop. XXXIV. and Cor.) that $FA \times A + FB \times B + FE \times E = FD \times A + B + E$. Whence $FD = \frac{A \times FA + B \times FB + E \times FE}{A + B + E} =$ sum of all the products of each body multiplied by its distance, divided by the sum of the bodies.

Cor. 1. *If a single body only was placed on the lever AF; then the distance of the center of gravity of that body, is equal to the sum of the products of all the particles of the body, each multiplied by its distance from a given point F, and divided by the body.*

For if A, B, E &c. are several particles of the body, then $A + B + E$ &c. = the body; and $FD = \frac{A \times FA + B \times FB + E \times FE}{\text{body}}$.

Cor. 2. *If there be several bodies A, B, E, &c. placed upon the lever AF. They act with the same force in turning the lever about any given point F, as if they were all placed in D the common center of gravity of all the bodies.*

SCHOLIUM.

If any of the bodies be placed on the contrary side of F, their respective products will be negative.

For

For they act the contrary way in turning the lever about. Fig. 17.

P R O P. XXXVI.

If several bodies A, B, E, G, H, be placed on the lever AH, and F be the center of gravity of all the weights. Then $FA \times A + FB \times B + FE \times E = FG \times G + FH \times H$. 18.

For let the lever be suspended on the point F, then the two ends will be in equilibrio, as F is the center of gravity. Let D be the center of gravity of A, B, E; and I the center of gravity of G, H. Then (Cor. Prop. XXXIII.) it is the same thing whether the bodies on one side be placed at A, B, E, or all of them in the point D. And whether those at the other end be placed at G, H; or all of them at I. But since F is the center of gravity, $DF \times \overline{A + B + E} = FI \times \overline{G + H}$, and therefore $A \times AF + B \times BF + E \times EF = G \times GF + H \times HF$ (by Prop. XXXIV.)

Cor. 1. *If several bodies A, B, E, G, H, be placed on an inflexible lever, and if $A \times FA + B \times FB + E \times FE = G \times FG + H \times FH$. Then F is the center of gravity of all the bodies.*

For no other point will answer the equation.

Cor. 2. *If several bodies A, B, E, G, H, be placed upon a lever AH, or suspended at these points by ropes; and if $A \times FA + B \times FB + E \times FE = G \times FG + H \times FH$; they will be in equilibrio upon the point F.*

This appears by Def. 12, and F is the center of gravity.

P R O P. XXXVII.

19. *If a heavy body AB, suspended by two ropes AC, BD, remains at rest; a right line perpendicular to the horizon, passing thro' the interfection F of the ropes; will also pass thro' the center of gravity G, of the body.*

If AC and BD be produced to F where they intersect; then (ax. 12.) it is the same thing whether the force acting in direction AC be applied to C or F; and whether the force acting in direction BD be applied to the point D or F. Suppose then that they both act at F, and then it is the same thing, as if the body was suspended at F by the two strings AF, BF. And since the body is at rest, therefore (Ax. 7.) the body, that is, the center of gravity G, is at the lowest place it can get; and therefore is in the plumb line FG. For if the body be made to vibrate, the center of gravity G will describe an arch of a circle, of which G (being in the perp. FG) is the lowest point.

Cor. 1. *Hence if GN be drawn parallel to AC; then the weight of the body, the forces acting at C and D, are respectively as FG, GN, and FN.*

This is evident by Prop. VIII.

Cor. 2. *If a heavy body AB, be supported by two planes, IKL, and EHG, at H and K; and HF and KF be drawn perpendicular to these planes; and if FG be drawn from the interfection F, perp. to the horizon, it will pass thro' the center of gravity G, of the body.*

For since the body is sustained by these planes, therefore the planes re-act against the body (by Prop. IX.), in the directions HF, KF perpendicular to these planes. Therefore it is the same thing

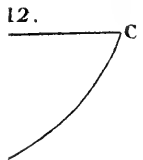
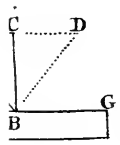
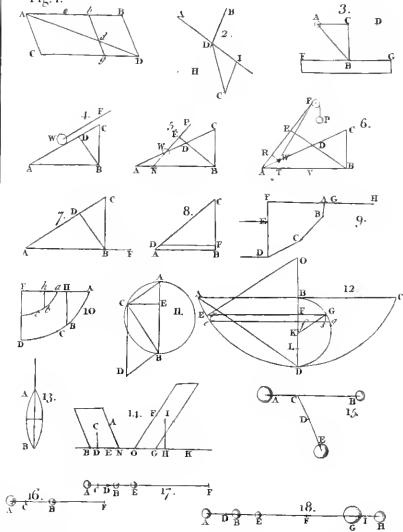

Fig. 1.



as if the body was sustained by the two ropes HF, Fig. 19. KF. For the directions and quantities of the forces, acting at H and K are the same in both cases. And further, if the body be made to vibrate round F, the points H, K will describe two arches of circles, coinciding with the touching planes at H, K; therefore moving the body up and down the planes, will be just the same thing, as making it vibrate in the ropes, HF and KF; and consequently, the body can rest in neither case, but when the center of gravity G is in the perpendicular FG.

S C H O L I U M.

If any body should deny the truth of this Prop. or its corollaries, against the clearest force of demonstration. It lies upon them to shew where the demonstration fails, or what step or steps thereof do not hold good, or are not truly deduced from the foregoing. If they cannot do this, what other reasons they may assign, can signify nothing at all to the purpose. And if such person, ignorant of the laws of nature, and the resolution of forces, would object against this practice, of substituting planes perpendicular to the lines or cords sustaining any weights, instead of these cords. Let him first read Sir J. Newton's *Principia*, Cor. 2. to the laws of nature, where he will see this practice exemplified, and then make his objections.

And for the sake of such persons as understand not how to apply the method of composition and resolution of forces, I shall add a few problems to prevent their being misled by the rash judgment of some people, who having brought out false solutions to some problems by their own ill management, condemn the method as erroneous; when the fault really lies in their own ignorance, and not at all in the method itself.

P R O P.

Fig.

P R O P. XXXVIII. *Prob.*

20. To determine the position of a beam CD, movable about the end C, and sustained by a given weight Q, hanging at a rope QAD, which goes over a pulley at A and is fixed to the other end D.

Draw AF, CK parallel to the horizon, FDE perp to it, and KD perp. to CD; and let G be the center of gravity, ω = weight of the beam. Then if the beam was to lie horizontally (Prop. XXXI. Cor. 2.) it would be GC : GD :: pressure at D : pressure at C; and GC : CD :: pressure at

D : ω ; whence the pressure at D = $\frac{GC}{CD} \omega$, horizontally. And (Prop. XIV.) CD : CE ::

$\frac{GC}{CD} \omega$; $\frac{CE \times CG}{CD^2} \omega$ = pressure in direction DK.

Produce AD to O, and draw OI parallel to CD. Then the beam is sustained by three forces in directions OD, DI and IO; and DI : DO :: S.IOD or ODC or ADC : rad; whence S.ADC : rad :: $\frac{CE \times CG}{CD^2} \times \omega$: force DO or Q = $\frac{\text{rad} \times CE \times CG}{S.ADC \times CD^2} \omega$.

Therefore $\omega : Q :: S.ADC : \text{rad} \times \frac{CE \times CG}{CD^2} ::$

S.ADC : $\frac{CG}{CD} \times S.FDC$, because $\frac{\text{rad} \times CE}{CD} = S.EDC$ or FDC.

P R O P. XXXIX. *Prob.*

21. Let the beam ED, be sustained by the weights P, Q, by means of the ropes DCP, EAQ, going over the pulleys C, A, in the horizontal line AC. To find the position of the beam; having the weights P, Q, given.

1 Way.

Let G be the center of gravity of the beam. Thro' D, E, draw HDS, FER perpendicular to AC,

AC: Then (Cor. 2. Prop. VIII.) S.EDS : P the Fig. tension of the thread CD :: S.CDS or CDH : 21.

$\frac{S.CDH}{S.EDS} \times P$ the tension of DE. Also, S.DER or

EDS : Q :: S.AER or AEF : $\frac{S.AEF}{S.EDS} \times Q$ the tension of DE in a contrary direction. Then as the beam is in equilibrio, these forces or tensions

balance one another; therefore $\frac{S.CDH}{S.EDS} \times P =$

$\frac{S.AEF}{S.EDS} \times Q$. Then P : Q :: S.AEF : S.CDH;

which may be otherwise expressed, for AE : rad ::

AF : S.AEF = $\frac{AF}{AE} \times rad$; and DC : rad :: HC :

$\frac{HC}{DC} \times rad = S.HDC$. Whence P : Q :: $\frac{AF}{AE} ::$

$\frac{CH}{CD} :: \frac{AF}{HC} : \frac{AE}{DC}$

2 Way.

Let R, S be the perpendicular pressures of the ends E, D. $w =$ weight of the beam. Then

(Cor. 2. Prop. XXXI.) R = $\frac{DG}{ED} w$, and S = $\frac{EG}{ED} w$.

And (Cor. 2. Prop. VIII.) S.AED : R or $\frac{DG}{ED} w ::$

S.AEF : tension of DE = $\frac{S.AEF \times DG}{S.AED \times ED} w$. And

S.CDE : S or $\frac{EG}{ED} w :: S.CDH : contrary tension$

of DE = $\frac{S.CDH \times EG}{S.CDE \times ED} w$, and these two forces

of DE being equal, we have $\frac{S.AEF \times DG}{S.AED \times ED} w =$

E S.CDH

$$\text{Fig. 21. } \frac{S.CDH \times EG}{S.CDE \times ED} \omega, \text{ and } \frac{S.AEF \times DG}{S.AED} = \frac{S.CDH \times EG}{S.CDE}$$

$$\text{Whence } EG : DG :: \frac{S.AEF}{S.AED} : \frac{S.CDH}{S.CDE} :: S.AEF \times S.CDE : S.CDH \times S.AED.$$

3 Way.

$$\begin{aligned} S.CDE : S.EDS :: S : P &= \frac{S.EDS}{S.CDE} \times S, \text{ and} \\ S.AED : S.REQ :: R : \frac{S.REQ}{S.AED} \quad R = Q. \text{ Then } P : \\ Q :: \frac{S.EDS}{S.CDE} \times S : \frac{S.REQ}{S.AED} \times R :: S.AED \times S : \\ S.CDE \times R :: (\text{last method}) S.AED \times \frac{EG}{ED} \omega : \\ S.CDE \times \frac{DG}{ED} \omega :: S.AED \times EG : S.CDE \times DG. \\ \text{And } S.AED : S.CDE :: P \times DG : Q \times EG. \end{aligned}$$

4 Way.

Draw Cm , Fn parallel to DE , and FE , HD perp. to the horizon. Then by the resolution of forces, $CD : Dm :: P : \frac{Dm}{CD}$ P = perpendicular force at D ; and $nE : EF :: Q : \frac{EF}{nE}$ Q = perpendicular force at E . Therefore $EG : GD :: \frac{Dm}{CD} P : \frac{EF}{nE} Q :: \frac{S.CDE}{S.CmD} \times P : \frac{S.FnE}{S.nFE} \times Q :: S.CDE \times P : S.AED \times Q$. For $S.CmD = S.mDE = S.FED = S.nFE$. That is, $EG : GD :: S.CDE \times P : S.AED \times Q$. As in the third way.

5 Way.

Let R , S be the perpendicular weights of the ends E , D ; or which is the same, the tensions of the perpen-

dicular ropes, FE, HD. By the resolution of Fig. forces, if Cm , Fn be parallel to DE. The force 21.
FE or R is equivalent to En , Fn ; and the force Dm or S, to DC, mC ; therefore $EF : Fn :: R : \frac{Fn}{FE} R =$ force at E in direction Fn . And $Dm :$

$mC :: S : \frac{mC}{mD} S =$ force at D in direction mC . But the beam being in equilibrio, these two opposite forces must be equal; therefore $\frac{Fn}{FE} R = \frac{mC}{mD} S$.

Whence $R : S :: \frac{mC}{mD} : \frac{Fn}{FE} :: \frac{S.CDH}{S.CDE} : \frac{S.AEF}{S.AED} :: S.AED \times S.CDH : S.AEF \times S.CDE$. But (Cor. 2. Prop. XXXI.) $R : S :: DG : EG$. Whence $DG : EG :: S.AED \times S.CDH : S.AEF \times S.CDE$; the same as by the 2d method. And the same thing likewise follows from the 1st and 4th method together.

From these several ways of proceeding, it is evident, that which ever way we take, the process if rightly managed always brings us to the same conclusion; and it comes to the same thing which way we use, so that we proceed in a proper manner. And this among other things, shews the great use and extent of that noble theory of the composition and resolution of forces.

What is calculated above is concerning the angles, or the position of the several lines to one another, depending on the several forces. Then in regard to the weight of the beam, put it = w , then $DC : Dm :: P : \frac{Dm}{DC} P = S$, and $En : EF :: Q : \frac{EF}{En} Q = R$. And $w = R + S = \frac{Dm}{DC} P + \frac{EF}{En} Q$, an equation shewing the relation of the weights to one another.

Fig.
21.

6 Way, by the center of gravity.

Produce AE, CD to B, and from B draw BGO thro' the center of gravity; which (by XXXVII.) will be perp. to AC, and therefore parallel to EF, DH. Then the angle EBG = AEF, and DBG = CDH. Then $EB : BD :: S.BDE$ or $CDE : S.BED$ or AED , and (Trigonom. B. II. Prop. V. Cor. 1.) $EG : GD :: EB \times S.EBG : BD \times S.DBG :: EB \times S.AEF : BD \times S.CDH :: S.CDE \times S.AEF : S.AED \times S.CDH$; the same as by the 2d way. Whence all the rest will be had as before.

Cor. It will be exactly the same thing, whether the weights P, Q, remain, or the strings AE, CD, be fixed in that position to two tacks, any way in these lines. And if a beam ED, hang upon two tacks A, C, by ropes fixed there; it makes no difference, if you put two pulleys instead of the tacks, for the ropes to go over, and then hang on the weights Q, P, equal to the tensions of the strings AE, CD.

For in both cases, the forces or the tensions of the strings, and their directions, remain the same. And there is nothing else to make a difference in the situation of the beam.

SCHOLIUM.

Every one that knows any thing of mechanical principles will easily understand, that if any forces, which keep a body at rest, be resolved into others, to have the same effect; the contrary forces, or those directly opposite, must act against a single point; or else the equilibrium will be destroyed. And therefore in the present Prop. suppose any one should divide the forces CD, AE, into the two HD, DY, and FE, EX, one perpendicular, the other parallel to the horizon. The forces HD, EF, will indeed balance the force of gravity at D and E, to which

Sect. III. CENTER OF GRAVITY.

53

Fig. 21.

which they are directly opposite. And therefore the beam will remain unmoved by these. But the equal forces DY, EX, being parallel, never meet in a point; but acting obliquely on the beam, one of them drawing at D in direction DY, and the other at E in direction EX, the effect will be, that they will turn the beam ED about the center of gravity G. Therefore to prevent this, the forces DY, EX, must be subdivided; that is, they must be resolved into others, one whereof is perp. to the horizon, the other parallel to ED. Then gravity will balance these perp. to the horizon, and the others, being equal and opposite, acting in the line EGD, act equally against any of the points D, G, or E. And so the beam will remain at rest. But this is much better done at once at the first, by dividing DC, EF, each into two forces, one perp. to the horizon, the other parallel to the beam ED. And then the opposite forces will exactly balance one another, and the beam remain unmoved.

P R O P. XL. *Prob.*

To find the position of the beam ED, hanging by the rope EBD, whose ends are fastened at E and D, and goes over a pulley fixed at B. 22.

Let G be the center of gravity of the beam, then (Prop. XXXVII.) BG will be perp. to the horizon. Then as the cord runs freely about the pulley B; therefore (Ax. 13.) the tension of the parts of the rope EB, BD are equal to one another, suppose = T. By the resolution of forces, the force EB is equivalent to EG, GB; and DB to DG, GB.

Therefore $BE : EG :: T : \frac{EG}{EB} T =$ force in direction EG. And $BD : DG :: T : \frac{DG}{BD} T =$ force in direction

Fig. direction DG, which is equal and opposite to that
 22. in EG; therefore $\frac{EG}{EB} T = \frac{DG}{DB} T$. Whence EG :
 EB :: DG : DB. And therefore BG bisects the
 angle EBD.

Cor. Hence ED : string EBD :: EG : EB the part
 EB of the string :: and so GD : DB the part DB of
 the string.

S C H O L I U M.

If GD be less than GE, then the center of gra-
 vity G, will be lowest, when the beam hangs per-
 pendicular with the end D downward. And in ma-
 ny cases it will be highest, when it hangs perpen-
 dicular, with the end E downward.

P R O P. XLI. Prob.

23. There is a beam BC hanging by a pin at C, and
 lying upon the wall BE; to find the forces or pressures
 at the points B, and C, and their directions.

Produce BC to K, so that CK may be equal to
 CB. Draw BA parallel, and CL perpendicular, to
 the horizon; and draw BL, CN, KI perp. to
 BCK. Thro' the center of gravity G, draw GF
 parallel to CL. By Prop. XIV. if a body lies
 upon an inclined plane, as BC; its weight, its in-
 clination down the plane, and pressure against it,
 are as BC, CA and AB; that is, as CL, CB and
 BL. Therefore if CL represent the weight of the
 body, CB will be the force urging it down the
 plane, and BL the total pressure against the plane.
 And since GF is parallel to CL, BL is divided in
 F, in the same ratio, as BC is divided in G. And
 therefore (Cor. 2. Prop. XXXI.) BF will be the
 part of the pressure acting at C, and FL the part
 acting at B. Make CN equal to BF, and complet
 the

the parallelogram CNIK, and draw CI. Then since BC or CK is the force in direction CK, and CN the force in direction CN; then by composition, CI will be the single force by which C is sustained, and CI its direction. But the triangles CKI, CBF are similar and equal, and $CI = CF$, and in the same right line; therefore CF is the quantity and direction of the force acting at C to sustain it. Therefore the weight of the body, the pressure at B, and the force at C; are respectively as CL, FL, and CF.

Cor. 1. Produce FG to intersect CN in H; then the weight of the body, the pressure at B, and the force acting at C; are respectively as HF, HC, and CF.

For in the parallelogram CLFH, $HF = CL$, and $HC = FL$.

Cor. 2. If the beam was supported by a pin at B, and laid upon the wall AC; the like construction must be made at B, as has been done at C, and then the forces and directions will be had.

Cor. 3. If a line perp. to the horizon be drawn thro' F, where the direction of the forces CF, and BF meet; it passes thro' G the center of gravity of the beam.

Cor. 4. It is all one whether the beam is sustained by the pin C and the wall BE, or by two ropes CI, BP acting in the directions FC, FB, and with the forces CF, FL.

SCHOLIUM.

The proportions and directions of the forces here found, are the same as in Prop. LXIV. of my large book of Mechanics, and obtained here by a different method. The principles here used are indisputable; and the principle made use of in that

Fig. LXIV. Prop. is here demonstrated in the third Cor.
23. so that the reader may depend upon the truth of
them all.

P R O P. XLII. *Prob.*

24. *BC is a heavy beam supported upon two posts KB, LC; to find the position of the posts, that the beam may rest in equilibrio.*

Let G be the center of gravity; draw BA parallel to the horizon, and BF, GD, CAN perpendicular to it. Then (Prop. XXXI. Cor. 2.) if BC be the weight of the body, CG will be the part of the weight acting at B, and BG the weight at C. Therefore make $CN = BG$, and $BF = GC$; and from N and F, draw NI, FK, parallel to BC; and make $NI = FK$, of any length, and lying contrary ways. Then draw IC and KB, which will be the position of the posts required.

For BF is the weight upon B; and CN, that upon C, which forces being in direction of the lines BF, CN, the beam will remain at rest by these forces. And the forces NI, FK, in direction BC, being equal and contrary, will also keep the beam in equilibrio, therefore the forces KB, IC, compounded of the others, will also keep the beam in equilibrio, acting in the directions KB, IC, or MB, LC.

Cor. 1. *Hence if DG be produced, it will pass thro' the intersection H, of the lines LC, MB.*

For the triangles INC, CGH are similar; therefore $IN : NC :: CG : GH$, the intersection with CL. Also the triangles KFB, BGH are similar; therefore $KF : BG :: BF : GH$ the intersection with MB, which must needs be the same as the other, since the three first terms of the proportion are the same; for $KF = NI$, $BG = NC$, and $BF = CG$.

Cor,

Cor. 2. *If a line be drawn thro' the center of gravity G, of the beam, perpendicular to the horizon; and from any point H in that line, (above or below G), the lines HBK and HCM be drawn; then the props BM and CL will sustain the beam in equilibrio.* Fig. 24.

Cor. 3. *If GO be drawn parallel to HC; then the weight of the beam, the pressure at C, and thrust or pressure at B; are respectively as HG, OG, and HO, and in these directions.*

Cor. 4. *It is all one for maintaining the equilibrium, whether the beam BC be supported by two posts or props MB, LC; or by two ropes BH, CH; or by two planes perpendicular to these ropes at B and C.*

For in all these cases the forces and directions are the same; and there is nothing else concerned, but the forces and directions.

SCHOLIUM.

It does not always happen that the center of gravity is at the lowest place it can get, to make an equilibrium. For here if the beam BC be supported by the posts MB, LC; the center of gravity is at the highest it can get; and being in that position, it has no inclination to move one way more than another, and therefore it is as truly in equilibrio, as if it was at the lowest point. It is true, any the least force will destroy that equilibrium, and then if the beam and posts be movable about the angles M, B, C, L, which is all along supposed, the beam will descend till it is below the points M, L, and gain such a position as described in Prop. XXXIX. and its Cor. supposing the ropes fixed at A, C (fig. 21.); and then G will be at the lowest point, and will come to an equilibrium again. In planes, the center of gravity G may be either at its highest or lowest point. And there are cases, when
the

Fig. the center of gravity is neither at its highest nor
24. lowest, as may happen in the case of Prop. XL.
so that they who contend, that in case of an equilibrium, the center of gravity must *always* be at the lowest place, are much mistaken, and know little about the principles of mechanics, or the nature of things.

Those that want to see more variety about the motion of bodies, on inclined planes; the pressure, and direction of the pressure of beams of timber; centers of gravity, and also the centers of oscillation and percussion, &c. may consult my large book of Mechanics.

S E C T. IV.

*The MECHANICAL POWERS; the Strength
and Strefs of Timber.*

P R O P. XLIII.

*IN a balance, where the arms are of equal length;
if two equal weights be suspended at the ends, they
will be in equilibrio.*

The balance is a freight inflexible rod or beam, turning about a fixed point or axle in the middle of it; to be loaded at each end with weights suspended there.

Let AB be the beam or lever, C the middle point or center of motion; D, E the weights hanging at the ends A and B. Then let the beam and the weights, or the whole machine, be suspended at C. And suppose the beam and the weights be turned about upon the center C; then the points A, B being equidistant from C will describe equal arches, and therefore the velocities will be equal, and if the bodies D and E be equal, then the motion of D will be equal to the motion of E, as their quantities of matter and velocities are equal; and consequently, if the beam and weights are set at rest, neither of them can move the other, but they will remain in equilibrio. 25.

Cor. If one weight be greater than the other; that weight and scale will descend, and raise the other.

S C H O L I U M.

The use of the balance, or a common pair of scales, is to compare the weights of different bodies;

Fig. dies; for any body whose weight is required, being put into one scale, and balanced by known weights put into the other scale, these weights will shew the weight of the body. To have a pair of scales perfect, they must have these properties.

1. The points of suspension of the scales, and the center of motion of the beam, A, C, B, must be in a right line.
2. The arms AC, BC, must be of equal length from the center.
3. That the center of gravity be in the center of motion C.
4. That there be as little friction as possible.
5. That they be in equilibrio, when empty.

If the center of gravity of the beam be above the center of motion, and the scales be in equilibrio, if they be put a little out of that position, by putting down one end of the beam, that end will continually descend, till the motion of the beam is stopt by the handle H. For by that motion, the center of gravity is continually descending, according to the nature of it. But if the center of gravity of the beam be below the center of motion; if one end of the beam be put down a little, to destroy the equilibrio; it will return back and vibrate up and down. For by this motion the center of gravity is endeavouring to descend.

P R O P. XLIV. *Prob.*

25. *To make a false balance; or one which is in equilibrio when empty, and also in equilibrio, when loaded with unequal weights.*

Make such a balance as described in the last Prop. only instead of making the center of motion in the middle at C, make it nearer one end, as at F. And make the weight of the scales such, that they may be in equilibrio upon the center F. Then if two weights D, E, be made to be in equilibrio in the two scales; these weights will be unequal, for

for they will be reciprocally as the lengths of the arms AF, BF. That is, $AF : BF :: E : D$.

Fig. 25.

For (Prop. XXXI. Cor. 1.) since F is the center of gravity of D and E, supposing them to act at A and B; therefore $FA \times D = FB \times E$. And $FA : FB :: E : D$. But AF is greater than FB, therefore E is greater than D.

Cor. 1. Hence to discover a false balance, make the weights in the two scales to be in equilibrio; then change the weights to the contrary scales. And if they be not in equilibrio, the balance is false.

Cor. 2. Hence also to prove a pair of good scales, they must be in equilibrio when empty, and likewise in equilibrio with two weights. Then if the weights be changed to the contrary scales, the equilibrium will still remain, if the scales are good.

Cor. 3. From hence also may be known what is gained or lost, by changing the weights, in a false balance.

Take any weight as 1 pound, to be put into one scale and balanced by any sort of goods in the other. Since $AF \times D = BF \times E$; let the weight

D be 1, then $E = \frac{AF}{BF}$ the weight of the goods in the scale E. Then changing the scales, let the

weight E be 1; then $D = \frac{BF}{AF}$ the weight of the

goods in the scale D. Then $\frac{AF}{BF} + \frac{BF}{AF} =$ whole

weight of the goods, and $\frac{AF}{BF} + \frac{BF}{AF} - 2 =$ gain

to the buyer in 2 lb. &c. Therefore

$\frac{AF^2 + BF^2 - 2AF \times BF}{AF \times BF} =$ gain in 2 lb. =

$\frac{AF - BF}{AF \times BF}$; and $\frac{AF - BF}{2AF \times BF} =$ gain in 1 lb.

There-

Fig. 25. Therefore if w is any weight to be bought; the gain to the buyer, for the weight w , by changing

the scales, will be $\frac{AF - BF)^2}{2AF \times BF} w$. For example,

if AF be 16, and BF 15; then the gain will be

$$\frac{16 - 15^2}{2 \times 16 \times 15} w = \frac{1}{480} w.$$

SCHOLIUM.

In demonstrating the properties of the mechanical powers; since the weight is commonly some large body whose weight is to be overcome or balanced; therefore the power which acts against it, will be most fitly represented by another weight; and thus the power and weight being of the same kind, may most properly and naturally be compared together. For such a weight may represent any power, as the strength of a man's hand, the force of water or wind, &c. And this weight representing the power, being suspended by a rope, may hang perpendicular where the power is to act perpendicular to the horizon; or may go over a pulley, when it acts obliquely.

P R O P. XLV.

26. *If the power and weight be in equilibrio upon any*
 27. *lever, and ac in lines perpendicular to the lever;*
 28. *then the power P is to the weight W ; as the dis-*
 29. *tance of the weight from the support C , is to the dis-*
tance of the power from the support.

There are four sorts of levers. 1. When the support is between the weight and the power. 2. When the weight is between the power and the support. 3. When the power is between the weight and the support. 4. When the lever is not straight but crooked.

A le-

A lever is any inflexible rod or beam, of wood or metal, made use of to move bodies. The support is the prop it rests on, in moving or sustaining any heavy body, and this is the same as the center of motion.

Fig.
26.
27.
28.
29.

Let the power P act at A by means of a rope; then as C is the prop or center of motion, if the lever be made to move about the center C , the arches described by A and W ; that is, the velocities of A and W will be as the radii CA and CW . But the velocity of P is the same as that of the point A . Therefore velocity of P : velocity of W :: CA : CW :: (by supposition) W : P ; therefore $P \times$ velocity of $P = W \times$ velocity of W . Consequently their motions are equal, and they cannot move one another, but must remain in equilibrio. And if they be in equilibrio, they must have this proportion assigned.

Cor. 1. *If a power P act obliquely against the lever WA ; the power and weight will be in equilibrio, when the power P is to the weight W ; as the distance of the weight CW , to CD the perpendicular, drawn from the support to the line of direction of the power.*

30.

For in this case WCD becomes a bended lever, and the power P acts perpendicular to CD at D ; and (Ax. 12.) it is all one whether the power acts at D or A , in the line of direction AD . And hence,

Cor. 2. *If any force be applied to a lever ACW at A , its power to turn it about the center of motion C , is as the sine of the angle of application CAD .*

For if CA be given, CD is as the sine of CAD .

Cor. 3. *In a streight lever, of these three, the power, the weight, and the pressure upon the support; the middlemost is equal to the sum of the other two.*

For the middle one acts against both the others and supports them.

Cor.

Fig. Cor. 4. *From the foregoing properties of the lever, the effects of several sorts of simple machines may be explained; and likewise the manner of lifting, carrying, drawing of heavy bodies, and such like.*

26. For example, if a given weight W is to be raised by a small power applied at A , the end of the lever AW . If we divide WA in C , so that it be as $CA : CW ::$ as the weight W : to the power P ; then fixing a prop or support at C or rather a little nearer W ; then the power, P with a small addition, will raise the weight W .

27. Again, if two men be to carry a weight W , upon the lever CA . The weight the man at A carries, is to the weight the man at C carries as CW , to AW . And therefore the lever or beam CA ought to be divided in that proportion at W , the place where the weight is to lie, according to the strength of the men that carry it.

31. Likewise if two horses be to draw at the swing-tree AB , by the ropes AF , BG ; and the swing-tree draws a carriage &c. by the rope CD ; then the force acting at A will be to the force acting at B , as BC to AC . And therefore BC ought to be to AC , as the strength of the horse at F , to the strength of the horse at G ; the weaker horse having the longer end. But it is proper to make the cross bar AB crooked at C ; that when the stronger horse pulls his end more forward, he may pull obliquely, and at a less distance from the center; whilst the weaker horse pulls at right angles to his end, and at a greater distance.

Again, such instruments as crows and handspikes are levers of the first kind, and are very useful and handy for raising a great weight to a small height. Also scissars, pinchers, snuffers, are double levers of the first kind, where the joint is the fulcrum or support. The oars of a boat, the rudder of a ship, cutting knives fixed at one end, are levers of the
second

second kind. Tongs, sheers, and the bones of animals, are levers of the third kind, a ladder raised upright, is a lever of the third kind. A hammer drawing out a nail is a lever of the fourth kind. 32.

The *Steel Yard* is nothing but a lever of the first kind, whose mechanism or construction is this. Let AB be the beam, C the point of suspension; P the power, movable along the beam CB. The beam being suspended at D, move the power P, along towards C, till you find the point O, where P reduces the beam to an equilibrium. Then at A hang on the weight W of 1 pound; and move P to be in equilibrio with it at 1; then hang on W of 2 pound, and shift P till it be in equilibrio, at 2. Proceed thus with 3, 4, 5, &c. pounds at W, and find the divisions 3, 4, 5, &c. Or if you will; after having found the points O, 1; make the divisions, 12, 23, 34, &c. each equal to O1. But for more exactness and expedition, having found the point O, where P makes the beam in equilibrio: hang on any known number of pounds, as W; and move P to the point B, where it makes an equilibrium. Then divide OB into as many equal parts as W consists of pounds: mark these divisions 1, 2, 3, 4, &c. Then any weight W being suspended at A. If P be placed to make an equilibrium therewith; then the number where P hangs will shew the pounds or weight of W.

To prove this, we must observe, that AC is the heavier end of the beam; therefore let Q be the *Momentum* at that end to make an equilibrium with P suspended at O; that is, let $Q = CO \times P$. But (Cor. 2. Prop. XXXVI.) $Q + CA \times W = CF \times P = CO \times P + OF \times P$. Take away $Q = CO \times P$, and then $CA \times W = OF \times P$. Whence $AC : P :: OF : W$. But AC and P are always the same; therefore W is as OF; that is,

Fig. if OF be 1, 2, 3, &c. divisions, then W is 1, 2, 3, 32. &c. pounds.

We may take notice that the divisions O₁, 12, 23, &c. are all equal; but CO may be greater or lesser, or nothing.

If you would know how much the weight P is, take the distance CA, and set it from O along the divisions O, 1, 2, 3, &c. and it will reach to the number of pounds. But this is of no consequence, being only matter of curiosity.

P R O P. XLVI.

33. *In the compound lever, or where several levers act upon one another, as AB, BC, CD, whose supports are F, G, I; the power P : is to the weight W :: as BF × CG × DI : to AF × BG × CI.*

For the power P acting at A : force at B :: BF : AF; and force or power at B : force at C :: CG : GB; and force or power at C : weight W :: DI : IC. Therefore *ex equo*, power P : weight W :: BF × CG × DI : AF × GB × IC.

And it is the same thing in the other kinds of levers, taking the respective distances, from the several props or supports.

P R O P. XLVII.

34. *In the wheel and axle; the weight and power will be in equilibrio, when the power P is to the weight W; as the radius of the axle CA, where the weight hangs; to the radius of the wheel CB, where the power acts.*

This is a wheel fixed to a cylindrical roller, turning round upon a small axis; and having a rope going round it.

Thro'

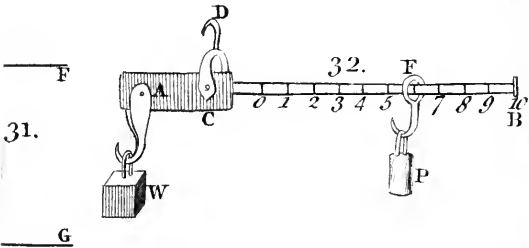
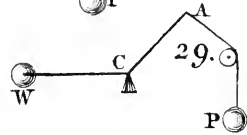
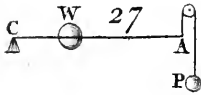
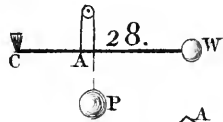
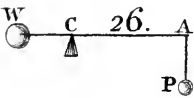
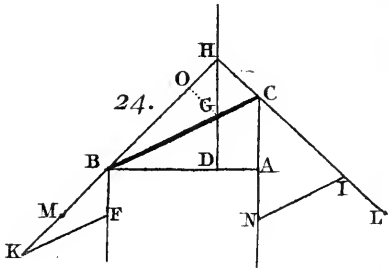
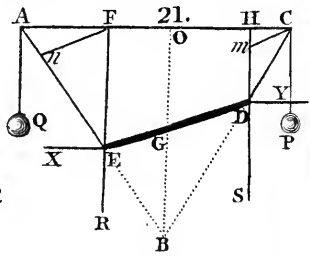
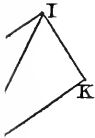
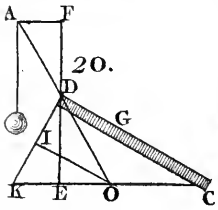

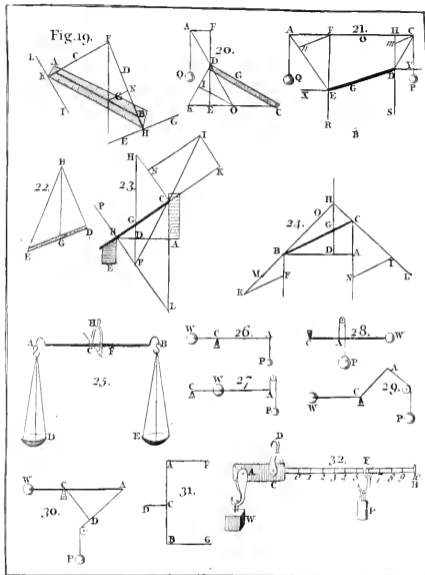

Thro' the center of the wheel C, draw the horizontal line BCA. Then BP and AW are perpendicular to BA; and BCA will be a lever whose support is C; and the power acts always at the distance BC, and the weight at the distance CA; which remain always the same. Therefore the weight and power act always upon the lever BCA. But by the property of the lever (Prop. XLV.) $BC : CA :: W : P$, to have an equilibrium. Fig. 34.

Otherwise,

If the wheel be set a moving the velocity of the point A or of W, is to that of B or P, as CA to CB; that is (by supposition), as $P : W$. Therefore $W \times \text{velocity of } W = P \times \text{velocity of } P$; therefore the motions of P and W, being equal, they cannot, when at rest, move one another.

Cor. 1. *If the power acting at the radius CB, act not at right angles to it; draw CD perpendicular to BP the direction of the power; then the power P : is to the weight W :: as the radius of the axle CA : to the perpendicular CD.* 35.

For in the lever DCA, whose support is C, the power P : weight W :: CA : CD.

Cor. 2. *In a roller turned round, on the axis or spindle FC, by the handle CBG; the power applied perpendicularly to BC at B, is to the weight W :: as the radius of the roller DA, to the length of the handle CB.* 36.

For in turning round, the point B describes the circumference of a circle; the same as if it was a wheel whose radius is CB.

SCHOLIUM.

All this is upon supposition that the rope sustaining the weight is of no sensible thickness. But if it is a thick rope, or if there be several folds of

Fig. it about the roller or barrel; you must measure
36. to the middle of the out side rope to get the radius of the roller. For the distance of the weight from the center is increased so much, by the rope's going round.

From hence the effects of several sorts of machines, or instruments, may be accounted for. A roller and handle for a well or a mine, is the same thing as a wheel and axle, a windless and a capstain in a ship is the same; and so is a crane to draw up goods with. A gimblet and an auger to bore with, may be referred to the wheel and axle.

The wheel and axle has a particular advantage over the lever; for a weight can but be raised a very little way by the lever. But by continual turning round of the wheel and roller, the weight may be raised to any height required.

P R O P. XLVIII.

37. *In a combination of wheels with teeth; if the power P be to the weight W :: as the product of the diameters of all the axles or pinions, to the product of the diameters of all the wheels; the power and weight will be in equilibrio.*

AC, CD are the radii of one wheel and its axle; DG, GH, the radii of another; and HI, IK are those of another. These act upon one another at D and H, then as the power or force P is propagated thro' all the wheels and axles to W; we must proceed to find the several forces acting upon them, by Prop. XXXVII. Thus,

$$CD : CA :: P : \frac{CA}{CD} P = \text{force acting at D.}$$

$$\text{and } GH : GD :: \frac{CA}{CD} P \text{ (force at D)} : \frac{CA \times GD}{CD \times GH} P \\ = \text{force acting at H.}$$

and

and $IK : IH :: \frac{CA \times GD}{CD \times GH} P$ (force at H) :

Fig.
37.

$\frac{CA \times GD \times IH}{CD \times GH \times IK} P = \text{force at K} = W$. And $CA \times GD \times IH \times P = CD \times GH \times IK \times W$; whence $P : W :: CD \times GH \times IK :: CA \times GD \times IH$.

Cor. 1. *If the weight and power be in equilibrio, and made to move; the velocity of the weight, is to the velocity of the power; as the product of the diameters of all the axles or pinions, to the product of the diameters of all the wheels. Or instead of the diameters, take the number of teeth in these axles and wheels that drive one another. And the same is true of wheels carried about by ropes.*

For the power is to the weight; as the velocity of the weight to the velocity of the power. And the number of teeth in the wheels and pinions, that drive one another, are as the diameters. And the ropes supply the place of teeth.

Cor. 2. *In a combination of wheels with teeth. The number of revolutions of the first wheel, is to the number of revolutions of the last wheel, in any time; as the product of the diameters of the pinions or axles, to the product of the diameters of the wheels: or as the product of the number of teeth in the pinions, to the product of the number of teeth in the wheels which drive them. And the same is true of wheels going by cords.*

For as often as the number of teeth in any pinion, is contained in the number of teeth of the wheel that drives it; so many revolutions does that pinion make for one revolution of the wheel.

SCHOLIUM.

A pinion is nothing but a small wheel, fixed at the other end of the axis, opposite to the wheel;

Fig. 37. and consists but of a few leaves or teeth ; and therefore is commonly less than the wheel. But in the sense of this proposition, a pinion may, if we please, be bigger than the wheel. As if we put the power and weight into the contrary places, the wheels will become the pinions, and the pinions the wheels, according to the meaning of this proposition.

P R O P. XLIX.

If a power sustains a weight by means of a fixed pulley ; the power and weight are equal : but if the pulley be movable along with the weight, then the weight is double the power.

A pulley is a small wheel of wood or metal, turning round upon an axis, fixed in a block ; on the edge of the pulley is a groove for the rope to go over.

38. Thro' the centers of the pullies, draw the horizontal lines AB, CD ; then will AB represent a lever of the first kind, and its support is the center of the pulley, which is a fixed point, the block being fixed at F. And the points A, and B, where the power and weight act, being equally distant from the support, therefore (Prop. XLV.) the power $P =$ weight W .

39. Also CD represents a lever of the second kind, whose support is at C, a fixed point ; the rope CG, being fixed at G. And the weight W acting at the middle of CD, and the power acting at D, twice the distance from C ; therefore (Prop. XLV.) the power P is to the weight $W ::$ as $\frac{1}{2}$ CD to CD ; or as 1 to 2.

Cor. Hence all fixed pulleys are levers of the first kind, and serve only to change the direction of the motion ; but make no addition at all to the power.

And

*And therefore if a rope goes over several fixed pul-
lies; the power is not increased, but rather decreased,
by the friction.*

Fig.
38.
39.

SCHOLIUM.

The use of a fixed pulley is of great service in raising a weight to any height, which otherwise must be carried by strength of men, which is often impracticable. Therefore if a rope is fixed to the weight at W (fig. 38.) and passed over the pulley BA; a man taking hold at P will draw up the weight, without moving from the place. And if the weight be large, several persons may pull together at F, to raise the weight up; where in many cases they cannot come to it, to raise it by strength.

P R O P. L.

In a combination of pulleys, all drawn by one rope going over all the pulleys; if the power P is to the weight W; as 1 to the number of the parts of the rope proceeding from the movable block and pulleys. Then the power and weight will be in equilibrio.

40.

Let the rope go from the power about the pulleys in this order, *ntours*, where the last part *s* is fixed to the lower block B. Now (Ax. 13.) all the parts of the rope *ntours* are equally stretched, and therefore each of them bears an equal weight; but the part *n* bears the power P, which goes to the fixed block A. All the other parts, sustain the weight and movable block B, each with a force equal to P. Therefore P is to the sum of all the forces, sustained by *o, r, s, t, v*, or the weight W, as 1 to the number of these ropes immediately communicating with the movable block B. And all the ropes having an equal tension, none of

F 4

them

7

Fig. them can move the rest, but they must remain in
40. equilibrio.

And if you take away the power at P , and apply a force at the rope t equal to P , to pull upwards in direction tA ; this will make no alteration, for the rope t draws from the movable block with the same force as before, and therefore the weight is sustained as before; for the upper pulley (by Prop. XLIX. Cor.) which the rope nt goes over, serves only to change the direction. And therefore as there are the same number of ropes still drawing from the movable block as before; the proposition holds good also in this respect. And it would be the same thing if the rope s was fixed to the weight W instead of the block B ; but had it been fixed to the block A , there must have been a pulley more below, and a rope more, which would have increased the power, according to the proposition.

Cor. 1. Hence it appears to be a disadvantage to the power to pull against the fixed block.

For the rope n has no more purchase, or no more effect than the rope t has which draws against the movable block; and therefore when one draws by the rope n , there must be a pulley more, which will create more friction.

Cor. 2. Hence one may explain the effects of all sorts of machines composed of pullies; or find out such a construction or combination of them as to answer any purpose desired. And to find its force, begin at the power, and call it 1; then all parts of the running rope that go and return about several pullies, must be each numbered alike. And any rope that acts against several others must be numbered with the sum of these. And so on to the weight.

For

For example; suppose a man wanted to draw himself up to the top of a house or a church. Get a pulley A fixed at the top, and place another B at the bottom. Let a rope be fixed to the upper block A, and brought down about the pulley B, and then put round the upper pulley, and so brought to the ground at H. Then if a cross stick CD be fastened to the block B by a rope; a man may get astride of the stick, and then draw himself up by the rope H. And the power to draw himself up, will be little more than $\frac{1}{3}$ of his weight. For the power at H, and the two parts of the rope going about the pulley B, sustain all his weight; and each of them sustains one third of it.

If instead of the stick CD, he takes a chair to sit in; then when he has drawn himself up to any height he pleases, he may fix the rope H to the chair, and then do any sort of business, as set up a dial, point the walls, and such like, as is commonly done.

Again, several tackles are used aboard a ship; for hoisting goods and the like. Let A, B be two blocks with pullies, the upper one being fixed, and let a weight W be suspended at the single pulley and rope, one end of the rope being fixed at F, and the other fastened to the movable block B. This pulley and rope BCF is called a *Runner*. Let the power be at P, call it 1; then all the ropes going from B to A, must be each of them 1, and the rope going from the block B, acting against these four must be marked 4, and the other part of it CF must also be 4. Lastly, the weight acting against these two, must be 8. And then the power P is to the weight W, as 1 to 8.

ABCD is another tackle with a runner BAD, A being a fixed pulley; the two blocks B, C, are both movable. The rope DAB is fixed to the weight

Fig. weight at D, and to the block B. The rope PB goes and returns about the pullies BC, and at last is fastened to the block C. Let P be the power, mark it 1, then the other parts of the rope between the blocks, must also be 1 apiece. Then CI acting against 3, must be 3. And AB is 4, as it acts against 4; likewise AD must be 4. Therefore the whole force that sustains the weight W is 3 and 4, or 7. And the power to the weight as 1 to 7.

44. The following is a sort of *Spanish burton*, A and F are two fixed pullies; C and B two movable ones. The rope going from the power P, goes round C, B, and A, and is fastened to the block B. Another rope is fastened to the block B, and goes over the pulley F, and is fixed to the block C. Then marking the power P, 1. Then each part of the rope, continued over C, B, and A to B again must be each 1. Then FC must be 2, as it acts against two parts; and likewise the other part of it FB must be 2. Then the whole that lifts the weight W, is $1 + 1 + 1 + 2 = 5$. And therefore the power is to the weight as 1 to 5.

The friction between the pullies and blocks is sometimes considerable. To remedy which, they must be as large as they can conveniently be made, and kept oiled or greased.

P R O P. LI.

45. *In the screw, if the power applied at E, be to the weight, pressure, &c. at B; as the distance of two threads of the screw, taken parallel to the axis of it, is to the circumference described by the power at E; then the weight and power will be in equilibrio.*

A screw is an instrument consisting of two parts AB, CD, fitting into one another. AB is the male screw, called the top or spindle; this is a long cylindrical body, having its surface cut into ridges and

34.

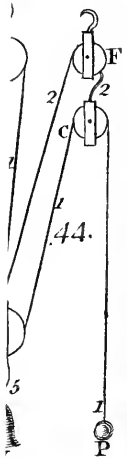
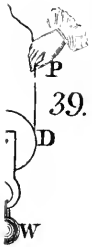
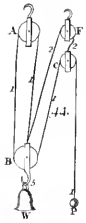
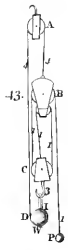
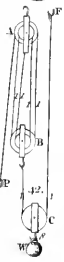
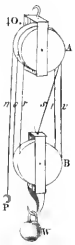
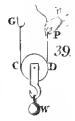
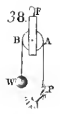
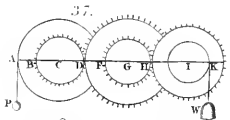
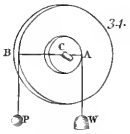
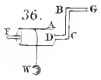

Fig. 33.



and hollows, that run round it in a spiral manner Fig. from one end to the other, at equal distances; 45. these risings are called threads, and so many revolutions as they make, so many threads the screw contains. CD is the female screw, or the plate, thro' which the other goes; its concavity is cut in the same manner as the male, so that the ridges of the male may exactly fit the hollows of the female. By reason of the winding of the threads, as the handle EF is turned one way or the other, the male AB goes further in or comes further out, of the female.

Let the point E of the handle, make one revolution, then the male AB will have advanced the distance between one thread and another, of the screw. Therefore if G represent any weight, which the end B acts against, it will be moved thro' the breadth of a thread, whilst the power moves thro' a circumference whose radius is EA. Therefore the velocity of G is to the velocity of E, as the breadth of a thread, to the circumference described by E; that is (by supposition) as the power at E, to the weight at G. Therefore $E \times \text{velocity of E} = G \times \text{velocity of G}$; and therefore their motions being equal, they will be in equilibrio.

Cor. By reason of the friction, if any weight is to be removed by a screw; the power must be to the weight; at least as the breadth of two threads of the screw, to the circumference described by the power; to keep the weight in equilibrio; and must be much more to move it.

For in the screw there is so much friction, that it will sustain the weight when the power is taken away. And therefore the friction is as great or greater than the power. And therefore the whole power applied must at least be doubled to produce any motion.

SCHOLIUM.

Screws with sharp threads have far more friction than those with square threads, and therefore move a body with more difficulty.

The screw, in moving a body, acts like an inclined plane. For it is just the same as if an inclined plane was forced under a body to raise it; the body being prevented from flying back, and the base of the plane being driven parallel to the horizon.

The use of this power is very great. It is of great service for fixing several things together by help of screw nails; it is likewise very useful for squeezing or pressing things close together, or breaking them; also for raising or moving large bodies. The screw is used in presses for wine, oil, or for squeezing the juice out of any fruit. The very friction of this machine has its particular use, for when a weight is raised to any height; if the power be taken away, the screw will retain its position, and hinder the weight from descending again by its friction, without any other power to sustain it.

In the common screw, such as is here supposed; the threads are all one continued spiral from one end to the other; but where there are two or more spirals, independent of one another, as in the worm of a jack; you must measure between thread and thread of the same spiral, in computing the power.

P R O P. LII.

In the endless screw, where the teeth of the worm or spindle AB, drives the wheel CD, by acting against the teeth of it. If the power applied at P, is to the weight W, acting upon the edge of the wheel at C :: as the distance of two threads or teeth, between fore side and fore side, taken along AB; is to the circumference described by the power P. Then the weight and power will be in equilibrio. 46.

The *endless* or *perpetual screw* is one that turns perpetually round the axis AB; and whose teeth fit exactly into the teeth of the wheel CD, which are cut obliquely to answer them. So that as AB turns round, its teeth take hold of the teeth of the wheel CD, and turns it about the axis I, and raises the weight W.

For by one revolution of the power at P, the wheel will be drawn forward one tooth; and the weight W will be raised the same distance. Therefore the velocity of the power, will be to that of the weight; as that circumference, to one tooth :: that is (by supposition) as the weight W, to the power P. Therefore the power $P \times$ velocity of $P = W \times$ velocity of W ; therefore their motions being equal, they will be in equilibrio.

Cor. *If a weight N be suspended at E on the axle EF; then if the power P, is to the weight N :: as the breadth of a tooth \times EF, to the circumference described by $P \times$ CD. They will be in equilibrio.*

Or if the power P; is to the weight N :: as radius of the axle EI, to the radius of the handle FP \times by the number of teeth in CD; they will be in equilibrio.

For

Fig. For power P : weight W :: 1 tooth : circumference.

46. and weight W : weight N :: EF : CD .

therefore P : N :: 1 tooth $\times EF$: $CD \times$ circumference.

Or thus, whilst EF turns round once, P turns round as oft as CD has teeth; whence El : $BP \times$ number of teeth :: velocity of N : velocity of P :: P : N .

SCHOLIUM.

47. As the teeth of the wheel CD , must be cut obliquely to answer the teeth or screw on AB ; supposing AB to lie in the plane of the wheel CD ; and therefore the wheel will be acted on obliquely by the screw AB . To remedy that, the screw AB may be placed oblique to the wheel, in such a position, that when the teeth of the wheel are cut streight or perp. to its plane, the teeth of the screw AB , may coincide with them, and fit them. By that means the force will be directed along the plane of the wheel CD . Fig. 47 explains my meaning.

This machine is of excellent use, not only in itself, for raising great weights, and other purposes; but in the construction of several sorts of compound engines.

P R O P. LIII.

48. *In the wedge ACD , if a power acting perpendicular to the back CD , is to the force acting against either side AC , in a direction perpendicular to it; as the back CD , to either of the sides AC ; the wedge will be in equilibrio.*

A wedge is a body of iron or some hard substance in form of a prism, contained between two isocetes triangles, as CAD . AB is the hight, and CD the back of it; AC , AD the sides.

Let AB be perp. to the back CD , and BE , BF , perp. to the sides AC , AD . Draw EG , FG parallel

rallel to BF , BE ; then all the sides of the parallelogram $BEGF$ are equal. The triangles EGB , ADC are similar; for draw EOF which will be perp. to AB ; then the right angled triangles AEB , AEO , are similar, and the angle $ABE = AEO = ACB$; that is, $GBE = ACD$, and likewise $BGE = ADC$, whence $CAD = BEG$.

Now let BG be the force acting at B , in direction BA , perp. to CD ; then (Prop. IX.) the forces against the sides AC , AD , will be in the directions EB , FB ; and therefore EB , EG will represent these forces (by Prop. VIII.), when they keep one another in equilibrio. Therefore force BG applied to the back of the wedge, is to the force BE , perp. to the side AC ; as BG to BE ; that is, (by similar triangles) as CD to CA .

Cor. 1. The power acting against the back at B , is to that part of the force against AC , which acts parallel to the back CD ; as the back CD , is to the height AB .

For divide the whole force BE into the two EO , OE ; the part EO acts parallel to CD ; therefore the force acting at B , is to the force in direction OE or BC ; as BG to OE ; that is, (by similar triangles) as CD to AB .

Cor. 2. By reason of the great friction of the wedge, the power at B , must be to the resistance against one side AC ; at least as twice the base CD , to the side AC , taking the resistance perp. to AC . Or as twice the base CD , to the height AB , for the resistance parallel to the base CD ; to overcome the resistance. But the power must be doubled for the resistance against both sides.

For since the wedge retains any position it is driven into; therefore the friction must be at least equal to the power that drives it.

Cor.

Fig. 48. Cor. 3. *If you reckon the resistance at both sides of the wedge; then, if there is an equilibrium, the power at B, is to the whole resistance; as the back CD, to the sum of the sides, CA, AD, reckoning the resistance perp. to the sides. Or as the back CD, to twice the height AB, for the resistance parallel to the back CD.*

This follows directly from the Prop. and Cor. 1.

SCHOLIUM.

The principal use of the wedge is for the cleaving of wood or separating the parts of hard bodies, by the blow of a mallet. The force impressed by a mallet is vastly great in comparison of a dead weight. For if a wedge, which is to cleave a piece of wood, be pressed down with never so great a weight, or even if the other mechanical powers be applied to force it in; yet the effect of them will scarce be sensible; and yet the stroke of a sledge or mallet will force it in. This effect is owing very much to the quantity of motion the mallet is put into, which it communicates in an instant to the wedge, by the force of percussion. A great deal of the resistance is owing to friction, which hinders the motion of the wedge; but the stroke of a mallet overcomes it; upon which account the force of percussion is of excellent use; for a smart stroke puts the body into a tremulous vibrating motion, by which the parts are disunited and separated; and by this means the friction or sticking is overcome, and the motion of the wedge made easy.

This mechanic power is the simplest of any; and to this, may be reduced all edge tools, as knives, axes, chissels, scissars, swords, files, saws, spades, shovels, &c. which are so many wedges fastened to a handle. And also all tools or instruments

ments with a sharp point, as nails, bodkins, needles, pins; and all instruments to cleave, cut, slit, chop, pierce, bore, and the like. And in general all instruments that have an edge or point. Fig. 48.

This Prop. is the same as Prop. XXX. in my large book of Mechanics, but demonstrated after a different way; and both come to the same thing, which evinces the truth thereof.

In this Prop. I have shewn under what circumstance, the wedge is in equilibrio; and that is, when the power is to the force against either side; as the back, is to that side. Therefore it must be very strange, that any body should understand it, as if I had said, that the power is to the whole resistance; as the back, is to one side only. They that do this must be blind or very careless.

Fig.

S E C T. V.

The comparative Strength of Beams of Timber, and the Stresses they sustain. The Powers of Engines, their Motions, and Friction.

P R O P. LIV.

49. *If a beam of wood AB, whose section is a parallelogram, be supported at the ends A and B, by two props C, D. And a weight E be laid on the middle of it, to break it; the strength of it will be as the square of the depth EF, when the breadth is given.*

For divide the depth EF into an infinite number of equal parts at $n, o, p, q, r, \&c.$ Now the strength of the beam consists of the strength of all the fibres $Fn, no, op, \&c.$ And to break these fibres, is to break the beam. Also when the beam is stretched by the weight, the fibres $Fn, no, op, \&c.$ are stretched by the power of the bended levers $AEF, AEn, AEo, \&c.$ whose support is at E, and power at A. For the pressure at A being half the weight E, we must suppose that pressure applied to A, to overcome the resistances at F, $n, o, \&c.$ Put the force or pressure at A = P, then P acts against all the fibres at F, $n, o, \&c.$ by help of the bended levers $AEF, AEn, AEo, \&c.$ But it is a known property of springs, fibres, and such like expanding bodies; that the further they are stretched, the greater force they exert, in proportion to the length. Therefore when the beam breaks; that is, when the tension of the fibre Fn is

is

is at its utmost extent; then those in the middle between F and E will have but half the tension, and those at all other distances, will have a tension proportional to that distance. This being settled, let the utmost tension of nF be $= 1$; then the tensions at n , o , p , &c. will be $\frac{En}{EF}$, $\frac{Eo}{EF}$, $\frac{Ep}{EF}$ &c. and the several forces, these exert against the point A, by means of the bended levers FEA , nEA , oEA , &c. will be $\frac{FE}{EA}$, $\frac{En^2}{EF \times EA}$, $\frac{Eo^2}{EF \times EA}$, $\frac{Ep^2}{EF \times EA}$ &c. and

the sum of all is $= \frac{1}{EF \times EA} \times$ into $EF^2 + En^2 + Eo^2 + Ep^2$ &c. to o . But (Arith. Inf. Prop. III.) the sum of the progression $EF^2 + En^2 + Eo^2$ &c. to o , is $\frac{1}{3} EF^2$. Therefore the sum of all the forces exerted at A; that is, $P = \frac{1}{EF \times EA} \times$

$\frac{1}{3} EF^2 = \frac{EF^2}{3EA}$. But $P = \frac{1}{2}$ weight E, therefore weight E $= \frac{2}{3} \times \frac{EF^2}{EA}$, when the beam breaks.

In like manner for any other depth Ep , the weight e that would break it is $= \frac{2Ep^2}{3EA}$. Whence the weight E to the weight e , is as EF^2 to Ep^2 ; that is, as the squares of the depths; for $\frac{2}{3EA}$ is a given quantity. Therefore the strength of the beams, are as the squares of the depths.

Cor. I. Hence the strengths of several pieces of the same timber, are to one another as the breadths and squares of the depths.

For by this Prop. they are as the squares of the depths when the breadth is given. And if the breadth be increased in any proportion, it is evi-

Fig. dent the strength is increased in the same proportion. So that a beam of the same depth being twice as broad is twice as strong, and thrice as broad is thrice as strong, &c.

50. Cor. 2. *If several beams of timber as AF of the same length, stick out of a wall; their strength to bear any weight W suspended at the end, is as the breadth and square of the depth.*

This follows from Cor. 1. only turning the beam upside down, to make the weight W suspended at A act downwards instead of pressing upwards.

49. Cor. 3. *If several pieces of timber be laid under one another, they will be no stronger, than if they were laid side by side.*

For not being connected together in one solid piece, they can only exert each its own strength, which will be the same in any position.

Cor 4. *Hence the same piece of timber is stronger when laid edgeways or with the flat side up and down, than when laid flat ways, or with the flat side horizontal; and that in proportion of the greater breadth to the lesser.*

For let B be the greater breadth, or the breadth of the flat side; b the lesser breadth, being the narrow side. Then the strength edge ways is BBb , and flat ways Bbb ; and they are to one another as B to b .

P R O P. LV.

49. *If a beam of timber AB be supported at both ends; and a given weight E laid on the middle of it; the stress it suffers by the weight, will be as its length AB.*

For half the weight E is supported at A, by the prop C; and the pressure at C is equal to it. And this pressure is always the same whatever length AB

AB is of. But it was shewn in the last Prop. that Fig. the pressure at A, breaks the fibres $Fn, no, op,$ &c. 49. by means of the bended levers AEF, AEn, AEo, &c. But (by Prop. XLV.) when the lengths EF, En, Eo, &c. are given, and the power at A also given; the effect at F, n, o, &c. is so much greater, as the arm AE is longer; that is, the stress at the section EF, is proportional to the distance AE, or to the length of the beam AB.

Cor. 1. *If AF be a beam sticking out of a wall, and a weight W hung at the end of it. The stress it suffers by the weight, at any point G, will be as the distance AG.* 50.

For this has the same effect, as in the case of this Prop. only turning the beam upside down. Or thus, suppose AHG to be a bended lever, whose fulcrum is H; then since GH is given, and the weight W; therefore by the power of the lever, the longer AH is, the more force is applied at G, or any other points, in GH, to separate the parts of the wood; and therefore the stress is as AG.

Cor. 2. *Therefore, instead of a weight, if any force be applied at the end A, of the lever AF; the stress at any part G, will be as the force, and distance AG.*

For augmenting the force, the stress is increased in the same ratio.

Cor. 3. *Hence also if any weight lie upon the middle of a horizontal beam; the stress there will be as the weight and length of the beam.* 49.

For if the weight be increased, the stress will be increased proportionally, all other circumstances remaining the same.

Cor. 4. *The stress of beams by their own weight, will be as the squares of the lengths.*

For here the weight is as the length.

Fig.

P R O P. LVI.

51. *If AB be a beam of timber whose length is given; and supported at the ends A and B; and if a given weight W be placed at any point of it G. The stress of the beam at G, will be as the rectangle AGB.*

Let the given weight be W , then (Cor. 3. Prop. XLV.) the weight W is equal to the pressure at both A and B. And (Cor. 2. Prop. XXXI.) pressure at A : pressure at B :: BG : AG, and press. A : press. A + press. B :: BG : BG + AG; that is, press. A : weight W :: BG : AB, therefore pressure at A = $\frac{BG}{AB} W$, and this is the force re-acting at A. But (Prop. LV. Cor. 2.) the stress at G by this force acting at the distance AG, is as the force multiplied by AG; that is, as $\frac{AG \times BG}{AB} \times W$. But W and AB are given, and therefore the stress at G is as $AG \times GB$.

Cor. 1. *The greatest stress of a beam is when the weight lies in the middle.*

For the greatest rectangle of the parts, is in that point.

Cor. 2. *The stress at any point P by a weight at G; is equal to the stress at G, by the same weight at P.*

For when the weight is at W , the stress at G is $AG \times GB$, and the stress at P = $\frac{BP}{BG} \times$ the stress at G = $\frac{BP}{BG} \times AG \times GB = BP \times AG$. Again, when the weight is at P, the stress at P is $AP \times PB$; and the stress at G = $\frac{AG}{AP} \times$ last stress = $\frac{AG}{AP} \times AP \times PB = AG \times PB$, the same as before.

P R O P.

P R O P. LVII.

If the distance of the walls AD and BC be given, 52.
and AB, AC be two beams of timber of equal thick-
ness; the one horizontal, the other inclined. And if
two equal weights P, Q, be suspended in the middle
of them; the stress is equal in both, and the one will
as soon break as the other, by these equal weights.

For (Prop. XIV.) $AC : AB :: \text{weight } P :$
 $\frac{AB}{AC} P =$ pressure against the plane, or the part of
the weight the beam AC sustains. And (Cor. 3.
Prop. LV.) the stress upon AC is $\frac{AB}{AC} P \times AC$ or
 $AB \times P$; and the stress on AB is $Q \times AB$, which
is equal to $AB \times P$, because the weights P, Q are
equal. Therefore, the stress being the same, and
the beams being of equal thickness, one will bear
as much as the other, and they will both break to-
gether.

Cor. 1. If the beams be loaded with weights in
any other places in the same perpendicular line as F,
G; they will bear equal stress, and one will as soon
break as the other.

For they are cut into parts similar to one ano-
ther; and therefore stress at F : stress by P ::
 $AFC : \frac{1}{4} AC^2 :: AGB : \frac{AB^2}{4} ::$ stress by B : stress
by Q or stress by P. Therefore stress at F = stress
at B.

Cor. 2. If the two beams be loaded in proportion
to their lengths; the stress by these weights, or by
their own weights, will be as their lengths; and there-
fore the longer, that stands aslope, will sooner break.

Fig. For the stress upon AC was $AB \times P$, and the
 52. stress on AB was $AB \times Q$; but since P and Q are
 to one another as AC and AB, therefore the stress
 on AC and AB will be as $AB \times AC$ and $AB \times$
 AB ; that is, as AC to AB. And in regard to
 their own weights, these are also proportional to
 their lengths.

P R O P. LVIII.

53. Let AB, AC, be two beams of timber of equal
 length and thickness, the one horizontal the other set
 sloping. And if CD be perp. to AB, and they be
 loaded in the middle with two weights P, Q, which
 are to one another as AC to AD. Then the stress
 will be equal in both, and one will as soon break as
 the other.

For (Prop. XIV.) $AC : AD :: P : \frac{AD}{AC} P =$
 pressure of P in the middle of AC. And by sup-
 position, $AC : AD :: P : Q$; therefore $\frac{AD}{AC} P =$
 Q, the weight in the middle of AB. Therefore
 the forces in the middle of the two beams are the
 same; and the lengths of the beams being the same,
 therefore (Prop. LV.) the stress is equal upon both
 of them; and being of equal thickness, if one
 breaks the other will break.

Cor. If the weights P, Q, be equal upon the two
 equal beams AB, AC. The stress upon AB will be
 to the stress upon AC, as AB or AC to AD. The
 same holds in regard to their own weights.

For the weight Q is increased in that proportion.

S C H O L I U M.

Many more propositions relating to the strength
 of timber might be inserted; as for example, if a
 weight

weight was disposed equally thro' the length of Fig. the beam AB (fig. 51.), supported at both ends; 53. the stress in any point G, is as the rectangle AGB. And the stress at any point G is but half of the stress it would suffer, if the whole weight was suspended at G. Also if AF (fig. 50.) be a beam fixed in a wall at one end, and a weight be dispersed uniformly thro' all the length of it. The stress at any point G, with that weight (or with its own weight, if it be all of a thickness), will be as AG square, the square of the distance from the end. And the stress at any point G by a weight suspended at A, will be double the stress at the same point G, when the same weight is dispersed uniformly thro' the part AG. They that would see these and such like things demonstrated, may consult my large book of Mechanics, to which I refer the reader.

P R O P. LIX.

If several pieces of timber be applied to any mechanical use where strength is required; not only the parts of the same piece, but the several pieces in regard to one another, ought to be so adjusted for bigness; that the strength may be always proportional to the stress they are to endure.

This Prop. is the foundation of all good Mechanism, and ought to be regarded in all sorts of tools and instruments we work with, as well as in the several parts of any engine. For who that is wise, will overload himself with his work tools, or make them bigger and heavier than the work requires? neither ought they to be so slender as not to be able to perform their office. In all engines, it must be considered what weight every beam is to carry, and proportion the strength accordingly. All levers

Fig. vers must be made strongest at the place where they are strained the most; in levers of the first kind, they must be strongest at the support. In those of the second kind, at the weight. In those of the third kind, at the power, and diminish proportionally from that point. The axles of wheels and pullies, the teeth of wheels, which bear greater weights, or act with greater force, must be made stronger. And those lighter, that have light work to do. Ropes must be so much stronger or weaker, as they have more or less tension. And in general, all the parts of a machine must have such a degree of strength as to be able to perform its office, and no more. For an excess of strength in any part does no good, but adds unnecessary weight to the machine, which clogs and retards its motion, and makes it languid and dead. And on the other hand, a defect of strength where it is wanted, will be a means to make the engine fail in that part, and go to ruin. So necessary it is to adjust the strength to the stress, that a good mechanic will never neglect it; but will contrive all the parts in due proportion, by which means they will last all alike, and the whole machine will be disposed to fail all at once. And this will ever distinguish a good mechanic from a bad one, who either makes some parts so defective, imperfect and feeble as to fail very soon; or makes others, so strong or clumsy, as to outlast all the rest.

From this general rule follows

Cor. 1. *In several pieces of timber of the same sort, or in different parts of the same piece; the breadth multiplied by the square of the depth, must be as the length multiplied by the weight to be born.*

For then the strength will be as the stress.

Cor. 2. *The breadth multiplied by the square of the depth, and divided by the product of the length and weight, must be the same in all.*

Cor.

Cor. 3. Hence may be computed the strength of timber proper for several uses in building. *As,* Fig.

1. To find the dimensions of joists and boards for flooring. Let b, d, l be the breadth, depth and length of a joist, n = number of them, x = their distance, g = depth of a board, w = weight; then $n b d d$ = strength of all the joists, and $w l$ = stress on them, also $n l g g$ = strength of the boards,

and $w x$ their stress; therefore $\frac{n b d d}{w l} = \frac{n l g g}{w x}$; and x

= $\frac{l g g}{b d d}$, for the distance of the joists, or the length

of a board between them. Or $b = \frac{l g g}{d d x}$, or $d d =$

$\frac{l g g}{b x}$, and so on, according to what is wanted.

2. To find the dimensions of square timber for the roof of a house. Let r, s, l be the length of the ribs, spars and lats, so far as they bear; x, y, z their breadth or depth, n the distances of the lats, w = weight upon a rib, c = cosine of elevation of the roof. Then by reason of the inclined plane,

$\frac{l w}{r} \times c$ = weight upon a spar. And $\frac{l n w}{r s}$ = weight upon a lat: for the ribs and lats lie horizontally.

Therefore (Cor. 2.) $\frac{x^3}{w r} = \frac{y^3}{\frac{s l w}{r} \times c} = \frac{z^3}{l \times \frac{l n w}{r s}}$.

Whence $x^3 = \frac{r r y^3}{c l s}$, and $x^3 = \frac{r r s z^3}{l n}$. Hence if any

one $x, y,$ or z be given, and all the rest of the quantities; the other two may be found. Or in general, any two being unknown, they may be found, from having the rest given.

For example, let $r = 9$ feet, $s = 4$ feet, $l = 15$ inches, $n = 11$ inches, $c = .707$ the cosine of 45° , the pitch of the roof. And assume $y = 2 \frac{1}{2}$ inches;

Fig. inches; then $x = 2 \frac{1}{2} \sqrt[3]{\frac{81}{3.535}} = 7.1$ inches. And

$$z = y \sqrt[3]{\frac{ln}{css}} = 2 \frac{1}{2} \sqrt[3]{\frac{55}{543}} = 1 \frac{1}{8} \text{ inches.}$$

54. 3. To find the curve ACB, into the form of which, if a joist be cut, on the upper or under side; and having the two sides parallel planes, which are perp. to the horizon. That the said joist shall be equally strong every where to bear a given weight, suspended on it.

Let the weight be placed in the ordinate CD; and the breadth of the beam, and the weight being given; then (Prop. LIV.) the strength at C is as CD^2 . And (Prop. LVI.) the stress is as ADB. Therefore that the strength may be as the stress, CD^2 is as the rectangle ADB; and therefore the curve ACB is an ellipsis.

55. 4. To find the figure of a beam AB, fixed with one end in a wall, and having a given weight W suspended at the other end B; and being every where of the same depth; it may be equally strong throughout.

Let CD be the breadth at C; then (Prop. LIV.) the strength is as CD. And (Cor. 1. Prop. LV.) the stress is as CB. Therefore CD is every where as CB, and therefore CDB is a plane triangle. And the beam is a prism, whose upper and under sides are parallel to the horizon.

56. 5. To find the figure of a beam AB, sticking with one end in a wall, and of a given breadth; having a weight W suspended at the end B; so that it may be equally strong throughout.

Let CD be the depth at C. Then since the breadth is given, the strength is as CD^2 . And the stress as DB; therefore CD^2 is as DB. Whence CD is a common parabola.

57. 6. To find the figure of a beam AB, of the same breadth and depth, sticking in a wall with one

one

one end, and bearing a weight suspended at the other end B; so that it may be equally strong throughout. Fig. 57.

Let CD be the thickness at O. Then the strength is as CD^3 , and the stress is as BO. Therefore BO is as CD^3 or as CO^3 . And consequently ACB is a cubic parabola, whose vertex is at B.

7. In like manner, if CBD be a beam fixed with one end in a wall, and all the sides of it be cut into the form of a concave parabola, whose vertex is at B. It will be equally strong throughout for supporting its own weight. 58.

For putting $BO = x$, $CO = y$, then by nature of the curve, $ay = xx$. But the solidity of CBD is $\frac{3.1416yyx}{5}$. And the center of gravity I, is distant $\frac{5}{6}x$ from B, therefore $OI = \frac{x}{6}$. Now CD^3 or $8y^3 =$ strength at O. And $CBD \times OI$ or $\frac{3.1416yyx}{5} \times \frac{x}{6} =$ stress. Therefore the strength : to the stress :: is as $8y^3$: to $\frac{3.1416y^2xx}{30} :: 8y : \frac{3.1416xx}{30} :: 8y : \frac{3.1416ay}{30} :: 340 : 3.1416a$, that is, in a given ratio. And as this happens every where, the solid is equally strong in all parts.

I must take notice here that the 116th figure in my large book of Mechanics, is drawn wrong. It should be concave instead of being convex.

8. Again, if AB be the spire of a church which is a solid cone or pyramid; it will be equally strong throughout for resisting the wind. For the quantity of wind falling on any part of it ACD, will be as the section ACD. Therefore let $AO = x$, $CD = y$. And $x = ay$, then the strength at O = y^3 , and if I be the center of gravity of ACD, then 59.
OI

Fig. $OI = \frac{1}{3} x$. And the stress at $O = \text{wind } ACD \times$
 59. $OI = xy \times \frac{1}{3} x$. Therefore the strength is to the
 stress :: as $y^3 : \frac{1}{3} xxy :: yy : \frac{1}{3} xx$ or $\frac{1}{3} aayy :: 3 : aa$;
 that is, in a given ratio. Therefore the spire is
 equally strong every where.

SCHOLIUM.

It is all along supposed that the timber, &c. is of equal goodness, where these proportions for strength are made. But if it is otherwise, a proper allowance must be made for the defect.

In these Propositions, I have called every thing *Strength*, that contributes in a direct proportion to resist any force acting against a beam to break it; and I call *Stress*, whatever weakens it in a direct proportion. But the whole may be referred to the article of strength; for what I have called stress may be reckoned strength in an inverse ratio. Thus the strength of a piece of timber may be said to be directly as the breadth and square of the depth, and inversely as its length, and the weight or force applied; and that is equivalent to taking in the stress. But I had rather keep them distinct, and refer to each of them their proper effects, as I have along done in the foregoing examples.

A piece of wood a foot long, and an inch square, will bear as follows; oak from 320 to 1100; elm from 310 to 930; fir from 280 to 770 pounds, according to the goodness.

P R O P. LX.

In any machine contrived to raise great weights; if the power applied, be to the weight to be raised; as the velocity of the weight, to the velocity of the power; the power will only be in equilibrio with the weight. Therefore to raise it, the power must be so far increased, as to overcome all the friction and resistance arising from the engine or otherwise; and then the power will be able to raise the weight.

A man would be much mistaken, who shall make an engine to raise a great weight, and give his power no greater velocity, in regard to the velocity of the weight; than the quantity of the weight has in regard to the quantity of the power. For when he has done that, his weight and power will but have equal quantities of motion, and therefore they cannot set one another a moving, but must always remain at rest. It is necessary then, that he do one of these two things. 1. That he apply a power greater than in that proportion, so much as to overcome all the friction and other accidental resistance that may happen: and in some engines these are very great. Or 2. He must so continue his engine, that the velocity of the power, which suppose he has given, may be so much greater than the velocity of the weight; as the quantity of the weight, friction, and resistance and all together, is greater than the power. This being done, the greater power will always overcome the lesser, and his engine will work.

If a man does not attend to this rule, he will be guilty of many absurd mistakes, either in attempting things that are impossible, or in not applying means proper for the purpose. Hence it is that engines contrived for mines and water-works so often

Fig. ten fail; as they must when either the quantity or velocity of the power is too little; or which is the same thing, when the velocity of the weight is too great, and therefore would require more power than what is proposed. As the weight is to move slow, the consequence is, that it will be so much a longer time in moving thro' any space. But there is no help for that. For as much as the weight to be raised is the greater, the time of raising it will be so much greater too.

Cor. 1. *Hence in raising any weight, what is gained in power is lost in time. Or the time of rising thro' any height will be so much longer as the weight is greater.*

If the power be to the weight as 1 to 20, then the space thro' which the weight moves will be 20 times less, and the time will be 20 times longer in moving thro' any space, than that of the power. The advantage that is gained by the strength of the motion, is lost in the slowness of it. So that tho' they increase the power, they prolong the time. And that which one man may do in 20 days, may be done by the strength of twenty men in one day.

Cor. 2. *The quantity of motion in the weight is not at all increased by the engine. And if any given quantity of power be immediately applied to a body at liberty, it will produce as much motion in it, as it would do by help of a machine.*

P R O P. LXI.

If an engine be composed of several of the simple mechanic powers combined together; it will produce the same effect, setting aside friction; as any one simple mechanic power would do, which has the same power or force of acting.

For let any compound engine be divided into all the simple powers that compose it. Then the force

or power applied to the first part, will cause it to act upon the second with a new power, which would be deemed the weight, if the machine had no more parts. This new power acting on the second part, will cause it to act upon the third part; and that upon a fourth, and so on till you come at the weight, which will be acted on, by all these mediums, just the same as by a simple machine whose power is equal to them all. Fig.

Cor. 1. Hence a compound machine may be made, which shall have the same power, as any single one proposed.

For if a lever is proposed whose power is 100 to 1; two levers acting on one another will be equivalent to it, where the power of the first is as 10 to 1, and that of the second also as 10 to 1, or the first 20 to 1, and the second 5 to 1; or any two numbers, whose product is 100.

Again, a wheel and axle whose power is as 48 to 1, may be resolved into two or more wheels with teeth, to have the same power; for example, make two wheels, so that the first wheel and pinion be as 8 to 1, and the second as 6 to 1. They will have the same effect as the single one. Or break it into three wheels, whose several powers may be 4 to 1, and 4 to 1, and 3 to 1.

If a simple combination of pullies be as 36 to 1; you may take three combinations to act upon one another, whose powers are 3 to 1, 3 to 1, and 4 to 1.

And after the same manner it is to be done in machines more compounded.

And this is generally done to save room. For when an engine is to have great power, it is hardly made of one wheel, it would be so large; but by breaking it into several wheels, after this manner; it will go into a little room, and have the

Fig. same power as the other. All the inconvenience is, it will have more friction; for the more parts acting upon one another, the more friction is made.

Cor. 2. *Hence also it follows, that in any compound machine, its power is to the weight, in the compound ratio of the power to the weight in all the simple machines that compose it.*

Cor. 3. *Hence it will be no difficult matter to contrive an engine that shall overcome any force or resistance assigned.*

For if you have the quantity of power given, as well as of the weight or resistance; it is but taking any simple machine as a lever, wheel, &c. so that the power may be to the weight in the ratio assigned, adding as much to the weight as you judge the friction will amount to. When this simple machine is obtained; break it or resolve it into as many other simple ones as you think proper; so that they may have the same power.

And as to the several simple machines, it matters not what sort they are of, as to the power; whether they be levers, wheels, pullies, or screws; but some are more commodious than others for particular purposes; which a mechanic will find out best by practice. In general, a lever is the most ready and simple machine to raise a weight a small distance; and for further distances, the wheel and axle, or a combination of pullies; or the perpetual screw. Also these may be combined with one another; as a lever with a wheel or a screw, the wheel and axle with pullies, pullies with pullies, and wheels with wheels, the perpetual screw and the wheel. But in general a machine should consist of as few parts as is consistent with the purpose it is designed for, upon account of lessening the friction; and to make it still less, the joints must be

be oiled or greased. All parts that act on one another must be polished smooth. The axles or spindles of wheels must not shake in the holes; but run true and even. Likewise the larger a machine is, if it be well executed, the better and truer it will work. And large wheels and pulleys, and small axles or spindles have the least friction.

The power applied to work the engine may be men or horses; or it may be weight or a spring; or wind, water, or fire; of which one must take that which is most convenient and costs the least. Wind and water are best applied to work large engines, and such as must be continually kept going. A man may act for a while against a resistance of 50 pounds; and for a whole day against 30 pounds. A horse is about as strong as five men.

If two men work at a roller, the handles ought to be at right angles to one another.

When a machine is to go regular and uniform, a heavy wheel or fly must be applied to it.

SCHOLIUM.

Two things are required to make a good engineer. 1. A good invention for the simple and easy contrivance of a machine, and this is to be attained by practice and experience. 2. So much theory as to be able to compute the effect any engine will have; and this is to be learned from the principles of Mechanics.

PROP. LXII.

The friction or resistance arising by a body moving upon any surface, is as the roughness of the surface, and nearly as the weight of the body; but is not much increased by the quantity of the surface of the moving body, and is something greater with a greater velocity.

It is matter of experience that bodies meet with a great deal of resistance by sliding upon one another,

Fig. ther, which cannot be entirely taken away, tho' the bodies be made never so smooth : yet by smoothing or polishing their surfaces, and taking off the roughness of them, this resistance may be reduced to a small matter. But many bodies, by their natural texture, are not capable of bearing a polish ; and these will always have a considerable degree of resistance or friction. And those that can be polished, will have some of this resistance arising from the cohesion of their surfaces. But in general, the smoother or finer their surfaces, the less the friction will be.

As the surfaces of all bodies are in some degree rough and uneven, and subject to many inequalities ; when one body is laid upon another, the prominent parts of one fall into the hollows of the other ; so that the body cannot be moved forward, till the prominent parts of one be raised above the prominent parts of the other, which requires the more force to effect, as these parts are higher ; that is, as the body is rougher. And this is similar to drawing a body up an inclined plane, for these protuberances are nothing else but so many inclined planes, over which the body is to be drawn. And therefore the heavier the body, the more force is required to draw it over these eminencies ; whence the friction will be nearly as the weight of the body.

But whilst the roughness remains the same, or the prominent parts remain of the same height, there will always be required the same force, to draw the same weight. And the increasing of the surface, retaining the same weight, can add nothing to the resistance on that account ; but it will make some addition upon other accounts. For when one surface is dragged along another, some part of the resistance arises from some parts of the moving surface, taking hold of the parts of the other, and tearing them off ; and this is called *wearing*. And there-

therefore this part of the friction is greater in a greater surface, in proportion to that surface. There is likewise in a greater surface, a greater force of cohesion, which still adds something to the friction. But the two parts of the friction, arising from the wearing and tenacity, are not increased by the velocity: but the other part, of drawing them over inclined planes, will increase with the velocity. So that in the whole, the friction is something increased by the quantity of the surface, and by the velocity, but not much. But more in some bodies than others, according to their particular texture.

Fig.

Cor. 1. *Hence there can be no certain rule, to estimate the friction of bodies; this is a matter that can only be decided by experiments. But it may be observed, that, ceteris paribus, hard bodies will have less resistance than softer; and bodies oiled or greased, will have far less.*

For the particles of hard bodies, cannot so well take hold of one another to tear themselves off. And when a surface is oiled, it is the same thing as if it run upon a great number of rollers or spheres.

Cor. 2. *Hence also a method appears of measuring the friction of a body sliding upon another body, by help of an inclined plane.*

Take a plank CB of the same matter, raise it at one end C so high, till the body whose friction is sought, being laid at C, shall just begin to move down the plane CB. Then the weight of the body, is to the friction as the base AB, to the height AC of the plane. For the pressure against the plane is the part of the weight that causes the friction, and the tendency down the plane is equal to the friction. And (Prop. XIV.) that pressure is to the tendency as AB to AC.

60

Fig. 60. If you push the body from C downward, and observe it to keep the same velocity thro' D to B; then you will have the friction for that velocity. If it increases its velocity, lower the end of the plank C; if it grows slower, raise the end C, till you get the body to have the same velocity quite thro' the plane. And so you will find what elevations are proper for each velocity; and from thence the ratio of AB to AC, or of the weight to the friction.

There is a way to make the experiment, by drawing the body along a horizontal plane, by weights hung at a string, which goes over a pulley; but the method here described is more easy and simple.

SCHOLIUM.

From what has been before laid down, it will be easy to understand the nature of engines, and how to contrive one for any purpose assigned. And likewise having any engine before us, we can by the same rules, compute its powers and operations.

Engines are of various kinds; some are fixed in a particular place, where they are to act; as wind-mills and water-mills for corn, fire engines for drawing water, gins for coal pits, many sorts of mills; pumps, cranes, &c. others are movable from one place to another, and may be carried to any place where they are wanted, as blocks, pulleys and tackles for raising weights, the lifting jack, and lifting stock, clocks, watches, small bellows, scales, steelyards, and an infinite number of others. Another sort of engines are such as are made on purpose to move from one place to another, such as boats, ships, coaches, carriages, waggon, &c. If any of these are urged forward by the help of levers, wheels, &c. By having the acting power given, the moving force that drives it forward, is easily found by the properties of these machines. Only observe, if the first acting
power

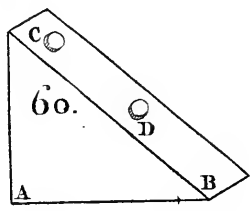
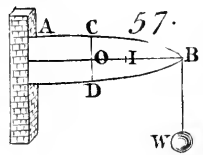
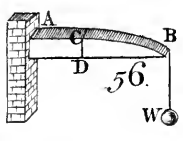
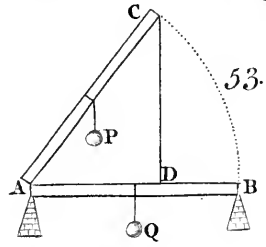
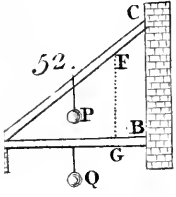
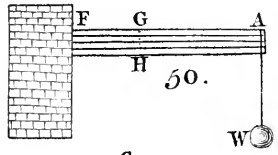
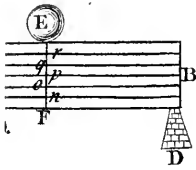
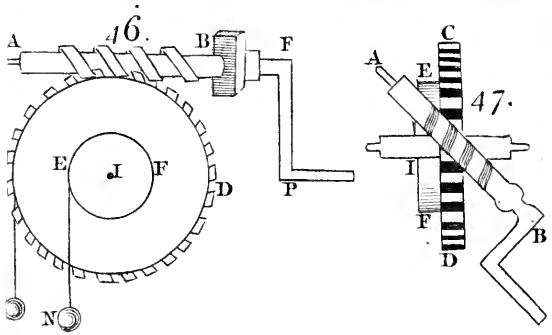
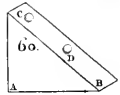
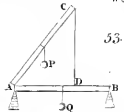
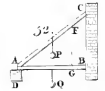
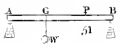
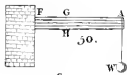
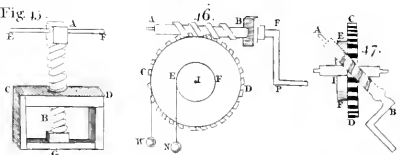

Fig 15.



power be external, as wind, water, horses, &c. Fig. you must not forget to add or subtract it, to or from the moving force before found; according as that first acting power conspires with, or opposes the motion of the machine; and the result is the true force it is driven forward with. I have only room to describe a very few engines, but those that desire it may see great variety in my large book of Mechanics.

A WHEEL CARRIAGE.

AB is a cart or carriage, going upon two wheels 61. as CD, and sometimes upon four, as all waggons do. The advantages of wheel carriages is so great, that no body who has any great weight to carry, will make use of any other method. Was a great weight to be dragged along upon a sledge or any such machine without wheels, the friction would be so great, that a sufficient force in many cases could not be got to do it. But by applying wheels to carriages, the friction is almost all of it taken away. And this is occasioned by the wheels turning round upon the ground, instead of dragging upon it. And the reason of the wheel's turning round is the resistance the earth makes against it at O where it touches. For as the carriage goes along, the wheel meets with a resistance at the bottom O, where it touches the ground; and meeting with none at the top at C, to balance it; that force at O must make it turn round in the order ODC, so that all the parts of the circumference of the wheel are successively applied to the earth. In going down a steep bank it is often necessary to tie one wheel fast, that it cannot turn round, this will make it drag; and by the great resistance it meets with, stops the too violent motion, the carriage would otherwise have, in descending the hill.

Fig. 61. But altho' all sorts of wheels very much diminish the friction; yet some have more than others; and it may be observed that great wheels, and small axles have the least friction. To make the friction as little as possible, some have applied friction wheels, which is thus; EG is the friction wheel running upon an axis I which is fixed in the piece of timber ES, which timber is fixed to the side of the carriage. KL is the axle of the carriage, which is fixed in the wheel CD, so that both turn round together. Then instead of the carriage lying upon the axle KL, the friction wheel FG lies upon the axle; so that when the wheel CD turns round, the axle causes the friction wheel, with the weight of the carriage upon it, to turn round the center I, which diminishes the friction in proportion to the radius IG: and there is the same contrivance for the wheel on the other side. But the wheel CD need not be fixed to the axle; for it may turn round on the axle KL, and also the axle turn round under the carriage.

In passing over any obstacles, the large wheels have the advantage. For let MN be an obstacle; then drawing the wheel over this obstacle, is the same thing as drawing it up the inclined plane MP, which is a tangent to the point M; but the greater the wheel CD is, the less is that plane inclined to the horizon.

Likewise great wheels do not sink so deep into the earth as small ones, and consequently require less force to pull them out again.

But there are disadvantages in great wheels; for in the first place, they are more easily overturned; and secondly, they are not so easy to turn with, in a strait road as small wheels.

The tackle of any carriage ought to be so fixed, that the horse may pull partly upwards, or lift, as well as pull forwards; for all hills and inequalities
in

in the road, being like so many inclined planes, Fig. the weight is most easily drawn over them, when 61. the power draws at an equal elevation.

A carriage with four wheels is more advantageous, than one with two only, but they are bad to turn; and therefore are obliged to make use of small fore-wheels. Broad wheels which are lately come into fashion, are very advantageous, as they sink but little into the earth. But there is a disadvantage attends them, for they take up such a quantity of dirt by their great breadth, as sensibly retards the carriage by its weight, and the like may be said of their own weight.

The under side of the axle where the wheels are, must be in a right line; otherwise if they slant upwards, the weight of the carriage will cause them to work toward the end, and press against the runners and lin pin. And as the ends of the axle are conical, this causes the wheels to come nearer together at bottom, and be further distant at the top; by which means the carriage is sooner overturned. To help this, the ends of the axle must be made as near a cylindrical form as possible, to get the wheels to fit, and to move free.

A H A N D M I L L.

Fig. 62. is a hand mill for grinding corn, A, B 62. the stones included in a wooden case. A the upper stone, being the living or moving stone. B the lower stone, or the dead stone, being fixed immovable. The upper stone is 5 inches thick, and a foot and three quarters broad; the lower stone is broader. C is a cog-wheel, with 16 or 18 cogs; DE its axis. F is a trundle with 9 rounds, fixed to the axis G, which axis is fixed to the upper stone A, by a piece of iron made on purpose. H is the hopper, into which the corn is put; I the shoe, to carry the corn by little and little thro' a hole at K,

Fig. K, to fall between the two stones. L is the mill
62. eye, being the place where the flour or meal comes out after it is ground. The under stone is supported by strong beams not drawn here. And the spindle G stands on the beam MN, which lies upon the bearer O, and O lies upon a fixed beam at one end, and at the other end has a string fixed, and tied to the pin P. The under stone is not flat, but rises a little in the middle, and the upper one is a little hollow. The stones very near touch at the out side, but are wider towards the middle to let the corn go in.

When corn is to be ground, it is put into the hopper H, a little at a time, and a man turns the handle D, which carries round the cog-wheel C, and this carries about the trundle F, and axis G, and stone A. The axis G is angular at K; and as it goes round, it shakes the shoe I, and makes the corn fall gradually thro' the hole K. And the upper stone going round grinds it, and when ground it comes out at the mill eye L, where there is a sack or tub placed to receive it. Another handle may be made at E like that at D, for two men to work, if any one pleases. In order to make the mill grind courser or finer, the upper stone A may be lowered or raised, by means of the string going from the bearer O; for turning round the pin P, the string is lengthened or shortened, and thereby the timbers O, M are lowered or raised, and with them the axle G and stone A. For the spindle G goes thro' the stone B, and runs upon the beam MN. The spindle is made so close and tight, by wood or leather, where it goes thro' the under stone, that no meal can fall thro'. The under side of the upper stone is cut into gutters in the manner represented at Q. It is a pity some such like mills are not made at a cheap rate for the sake of the poor, who are much distressed by the roguery of the millers.

Fig.

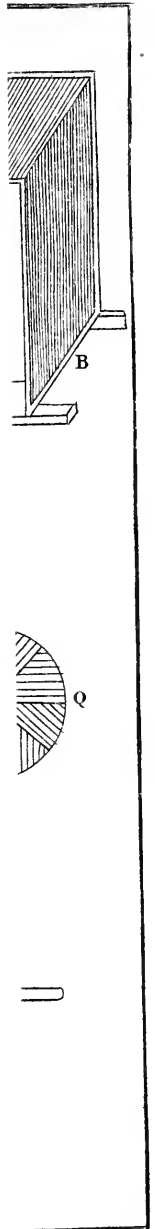

Fig. 61.

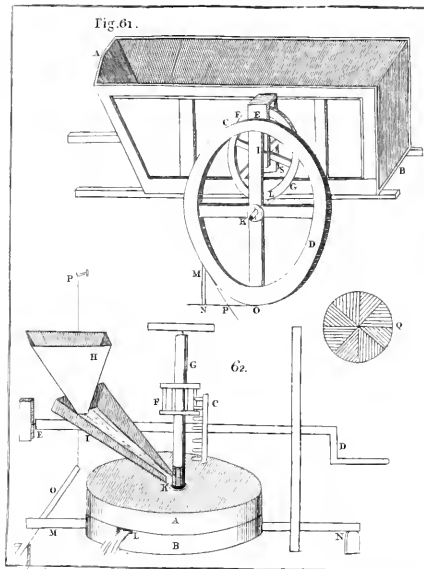

Fig. 63. is a sort of crane, BC an upright post, AB a beam fixed horizontally at top of it; these turn round together on the pivot C, and within the circle S, which is fixed to the top of the frame PQ. EF is a wooden roller, or rather a roller made of thin boards, for lightness, and all nailed to several circular pieces on the inside. GH a wheel fixed to the roller, about which goes the rope GR. IK, LN, two other ropes; fixed with one end to the cross piece AB, and the other end to the roller EF. W a weight equal to the weight of the wheel and roller, which is fastened to a rope which goes over the pulley O, and then is fastened to a collar V, which goes round the roller. ET is another rope with a hook at it to lift up any weight, the other end of the rope being fixed to the roller; here are in all five ropes.

To raise any weight as M, hang it upon the hook T, then pulling at the rope R which goes about the wheel GH, this causes the wheel and roller to turn round, and the ropes IK, LN to wind about it, by which means the wheel and axle rises; and by rising, folds the rope TE about the roller the contrary way, and so raises the weight M. When the weight M is raised high enough, a man must take hold of the rope T with a hook, by which the whole machine may be drawn about, turning upon the centers C and S. And then the weight M may be let down again. The weight of the wheel and roller do not affect the power drawing at R, because it is balanced by the weight W. There is no friction in this machine but what is occasioned by the collar V, and the bending of the ropes. And the power is to the weight in this crane, as the diameter of the roller to the radius of the wheel GH.

Fig. An ENGINE for raising WEIGHTS.

64. Fig. 64. is an engine composed of a perpetual screw AB, and a wheel DE with teeth, and a single pulley H. FG is an axle, about which a rope goes, which lifts the pulley and weight W. BC is the winch, to turn it round withal. As the spindle AB is turned about, the teeth of it takes the teeth of the wheel DE, and turns it about, together with the axle FG, which winds up the rope, and raises the pulley H, with the weight W. The power at C, is to the weight W, as diameter FG \times by the breadth of one tooth, is to twice the diameter DE \times circumference of the circle described by C.

A FULLING MILL.

65. Fig. 65. is a fulling mill. AB a great water wheel, carried about by a stream of water, coming from the trough C, and falling into the buckets D, D, D whose weight carries the wheel about; this is a breast mill, because the water comes no higher than the middle or breast of the wheel; EF is its axis; I, I; K, K, two lifters going thro' the axle, which raise the ends G, G of the wooden mallets GH, GH, as the wheel goes about; and when the end G slips off the cog or lifter K or I, the mallet falls into the trough L, and each of the mallets makes two strokes for one revolution of the wheel. The mallets move about the centers M, M. These troughs L, L, contain the stuff which is to be milled, by the beating of the mallets. N, N, is a channel to carry the water, being just wide enough to let the wheel go round. And the wheel may be stopt, by turning the trough C aside, which brings the water. In this engine more mallets may be used, and then more pins or lifters must be put thro' the axis EF.

Fig.

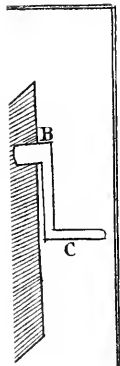

П.разор.

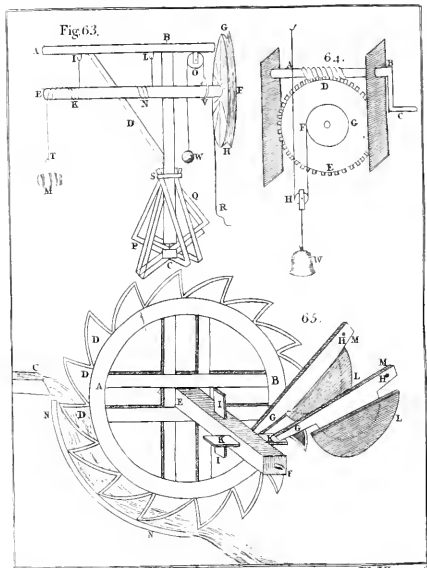

Fig. 66. is a common *Pocket Watch*. AA the *balance*, BB the *verge*; C, C, two *palats*. D the *crown wheel* acting against the palats C, C; E its *pinion*. F the *contrate wheel*, G its *pinion*. H the *third wheel*, I its *pinion*. K the *second wheel* or *center wheel*, L its *pinion*. M the *great wheel*, N the *fusée* turning round upon the spindle of M. O the *spring box*, having a spring included in it. PP the *chain* going round the spring box O, and the fusée N. This work is within the watch between the two plates. Here the face is downward, and in the watch the wheel K is placed in the center, and the others round about it. Here I have placed them so as best to be seen, which signifies nothing to the motion. The balance AA is without the plate, covered by the cock X. The minute hand Q goes upon the axis of the wheel K.

Then between the upper plate and the face, we have V the *cannon pinion* or *pinion of report*. Z the *dial wheel*. T the *minute wheel*. S the *pinion* or *nut*, fixed to it. The socket of the cannon pinion V goes into the socket of the wheel Z, and are movable about one another, and both go thro' the face; on the socket of the pinion Z is fixed the hour hand R; and on the socket of V is fixed the minute hand Q. Likewise the socket of V is hollow, and both go upon the arbour of the wheel K, which reaches thro' the face, and are fastened there. The wheel and socket, T, S are hollow, and go upon a fixed axle on which they turn round.

When the chain PP is wound up, upon the fusée N; the spring included in the box O, draws the chain PP, which forces about the wheel M, the fusée being kept from slipping back, by a catch on purpose. Then M drives L and K, and K drives I, and H drives G, and F drives E, and the teeth of the crown wheel D, act against the palats C, C alternately, and cause the balance AA to
vibrate

Fig. vibrate back and forward, and thus the watch is kept going.

66. The cannon pinion, and dial wheel V and Z, and the hands Q, R, being put upon the arbor of K at W; and fastened there, by means of a shoulder which is upon the axis, and a brass spring; as the wheel K goes round, it carries with it the pinion V with the minute hand, and V drives T together with S; and S drives Z with the hour hand.

The numbers of the wheels and pinions, (that is the teeth in them) are, $M = 48$, $L = 12$, $K = 54$, $I = 6$, $H = 48$, $G = 6$, $F = 48$, $E = 6$, $D = 15$, and 2 palats. The *train*, or number of beats in an hour, is 17280, which is about $4\frac{3}{4}$ beats in a second. Also $V = 10$, $Z = 36$, $S = 12$, $T = 40$.

The wheel M goes round 6 times in 24 hours, therefore K goes round $\left(\frac{48}{12}\right)$ 4 times as much; that is, 24 times, or once in an hour, and the hand Q along with it; therefore Q will shew minutes. Then as V goes round once in an hour, T will go round $\left(\frac{10}{40}\right)$ $\frac{1}{4}$ of that, or $\frac{1}{4}$ the circumference;

and as S goes $\frac{1}{4}$, Z will go $\left(\frac{12}{36}\right)$ $\frac{1}{3}$ of that, or $\frac{1}{12}$ of the circumference in an hour, and therefore as R goes along with it, R will shew the hours. The wheels and pinions T, Z, and S, V, are drawn with the face upwards. And the whole machine included in a case is but about two inches diameter. There is a spiral spring fixed under the balance AB, called the *regulator*, which gives it a regular motion; and likewise abundance of small parts helpful to her motion, too long to be described here.

The

The way of writing down the numbers, is thus, Fig. 66.

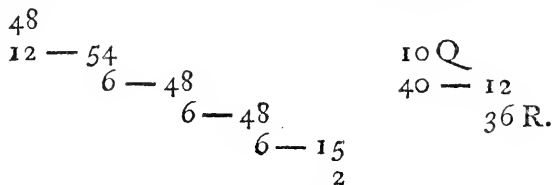

Explanation. The wheel with 48 drives a pinion of 12, and a wheel of 54 on the same arbor. The wheel 54 drives the pinion 6 with the wheel 48 on the same arbor. The wheel 48 drives the pinion 6 and wheel 48 on the same arbor. The wheel 48 drives the pinion 6 and wheel 15 on the same arbor. And the wheel 15 drives the two palats.

Again the wheel 54 has the pinion 10 on its arbor, and the hand Q; and the pinion 10 drives the wheel 40, with the pinion 12. And the pinion 12 drives the wheel 36 with the hand R.

As this machine is moved by a spring, it is subject to very great inequalities of motion, occasioned by heat and cold. For hot weather so relaxes, softens, and weakens the main spring, that it loses a great deal of its strength, which causes the watch to lose time and go too slow. On the other hand, cold frosty weather so affects the spring, and it is so condensed and hardened, that it becomes far stronger; and by that means accelerates the motion of the watch, and makes her go faster. The difference of motion in a watch, thus occasioned by heat and cold, will often amount to an hour, and more in 24 hours. To remedy this, there is a piece of machinery, called the *Slide*, placed near the regulating spring; which being put forward or backward, shortens or lengthens the spring, so as to make her keep time truly.

Some people have been so silly as to think, that the greater strength of a spring arises wholly from

Fig. from its being made shorter, as this happens to be one of the effects of cold. But it is easily demonstrated that this is not the cause. For let AB be a spring as it is dilated by heat, and ab the same spring contracted by cold. Now if the spring has been contracted in length, it must be proportionally contracted in all dimensions. Let l, b, d , denote the length, breadth, and depth, in its cold, and least dimensions; and rl, rb, rd , the length, breadth, and depth, in its hot and greatest dimensions. Then (Prop. LIV.) the strength of the longer, to the strength of the shorter, will be as $\frac{rb \times rrd}{rl}$ to $\frac{bdd}{l}$ (considering it weakened by the length), and that is as rr to 1, or as AB^2 to ab^2 . So that the longer spring, upon account of its being affected with heat, is so far from being weaker, than the shorter affected with cold, that it is the stronger of the two. And therefore this difference is not to be ascribed merely to the lengthning or shortning thereof; but must be owing to the nature, texture and constitution of the steel, as it is some way or other affected and changed by the heat and cold.

And that there is some change induced by the cold, into the very texture of the metal, is evident from this, that all sorts of tools made of iron or steel, as springs, knives, saws, nails, &c. very easily snap and break in cold frosty weather, which they will not do in hot weather. And that property of steel springs is the true cause, that these sorts of movements can never go true.

66. To make a calculation of the different forces requisite to make a watch gain or lose any number of minutes, as suppose half an hour in 24; and I have often experienced it to be more. By Cor. 4. Prop. VI. the product of the force and square of the

the time, is as the product of the body and space described, which here is a given quantity. For the matter of the balance remains the same in hot as cold weather; and so does the length of the swing, which here is the space described. Therefore the force is reciprocally as the square of the time of vibrating, or directly as the square of the number of vibrations in 24 hours. Therefore the force with the warm spring, is to the force with the cold one; as the square of $23\frac{1}{2}$ hours, to the square of 24; that is, nearly as 23 to 24. So that if a spring was to contract half an inch in a foot in length, without altering its other dimensions, it would but be sufficient to account for that phenomenon; but this is forty times more than the lengthening and shortening by heat and cold, for that does not alter so much as a thousandth part, as is plain from experiments.

The case being thus, a clock or watch going by a spring, can never be made to keep time truly, except it be always kept to the same degree of heat or cold, which cannot be done without constant attendance. And if any sort of mechanism be contrived to correct this; yet as such a thing can only be made by guess, it cannot be trusted to at sea, but only for short voyages. But no motion however regular, can ever answer at sea, where the irregular motion of the ship will continually disturb it; add to this, that the small compass a watch is contained in, makes it easier disturbed, than a larger machine would be; but to suppose that any regular motion can subsist among ten thousand irregular motions, and in ten thousand different directions, is a most glaring absurdity. And if any one with such a machine would but make trial of it to the East Indies, he would find the absurdity and disappointment. And therefore I never expect to see such a time keeper, or any such thing as a watch or clock

Fig. going by a spring, to keep true time at sea. But
66. time will discover all things.

As to pendulum clocks, their irregularity in the same latitude is owing to nothing but the lengthening or shortning of the pendulum; which is a mere trifle to the other. But then they would be infinitely more disturbed at sea, than a watch; and in a storm could not go at all. In different latitudes too, another irregularity attends a pendulum, depending on the different forces of gravity. Tho' this amounts but to a small matter, yet it makes a considerable variation, in a great length of time. For in south latitudes, where the gravity is less, a clock loses time. And in north latitudes, where the gravity is greater, it gains time. So that none of these machines are fit to measure time at sea, altho' ten times ten thousand pounds should be given away for making them.

A DESCENDING CLOCK.

68. Fig. 68. is a clock descending down an inclined plane. This consists of a train of watch work, contained between two circular plates AB, CD, 4 inches diameter, fixed together by a hoop an inch and half broad, inclosing all the work. The inner work consists of 5 wheels, the same as in a watch, only there is a spur wheel instead of the contrate wheel, as 4; *b* is the balance, whose pallets play in the teeth of the crown wheel 5. Here is no spring to give it motion, but instead thereof, the weight *W* is fixed to the wheel 1, and so adjusted for weight, that it may balance the lower side, and hinder it from rolling down the plane. Now whilst the weight *W* moves the wheel 1, this wheel by moving about, causes the weight *W* to descend, by which it ceases to be a balance for the opposite side, and therefore that side begins to descend,

scend, till the weight *W* be raised high enough again to become a balance, which must be about the position it appears in the figure. Thus whilst wheels move gradually about, the weight *W* descends gradually, which makes the body of the machine turn gradually round, and descend down the inclined plane *PQ*; making one revolution in 12 hours. And therefore to have her to go 24 or 30 hours; the length of the plane *PQ* must be 2 or $2\frac{1}{2}$ circumferences of the plates. Before the weight *W* is fixed to the wheel 1, some lead or brass must be soldered on the side *E* opposite to the wheels 2, 3, 4, &c. for the wheel 1 must be in the center. And then the lead or brass must be filed away till the center of gravity of the machine be in the center of the plates. And to hinder the machine from sliding, the edges of the plates must be lightly indented. The inclined plane *PQ* may be a board, which must be elevated 10 or 12 degrees, but that is to be found by trials; for if she go too slow the end *P* must be raised; but if too fast it must be lowered. When the clock has gone the length of the board to *Q*, it must be set again at *P*. The fore side *CD* is divided into hours, and a pin is fixed in the center at *G*, on which the hand *FGH*, always hangs loosely in a perp. position, with the heavy end *H* downward. And the end *F* shews the hour of the day. So that the hours come to the hand, and not the hand to the hours.

The board *PQ* must be perfectly streight from one end to the other, or else she will go faster in some places, and slower in others.

The circle with hours ought to be a narrow rim of brass, movable round about, by the help of of one or more pins placed in it; so that it may be set to the true time.

Fig. The weight W serves for two uses, 1, to be a counterpoise to the side A ; and 2, by its weight to put the clock in motion.

The weight W must be so heavy as to make the clock keep time, when it has a proper degree of elevation as 45 degrees; and then the board must have an elevation of 10 or 12 degrees. If she go too fast, with these positions, take some thing off the weight; if too slow, add something to it.

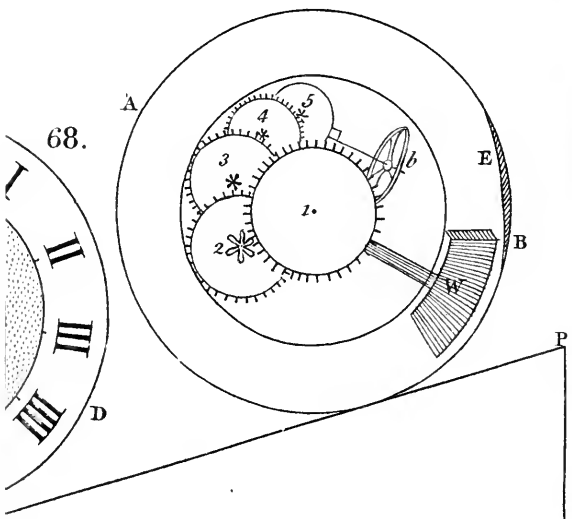
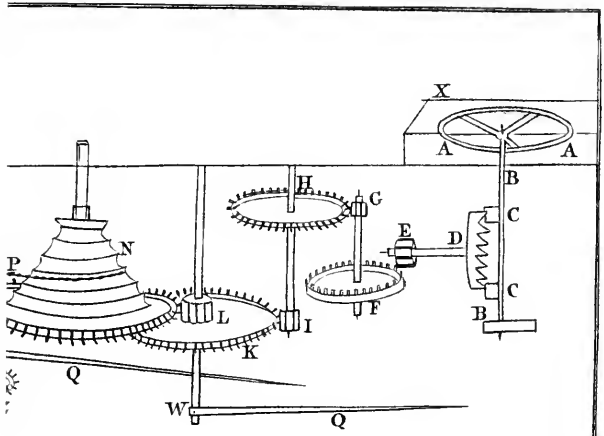
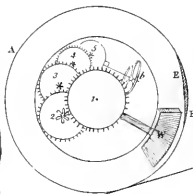
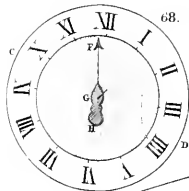
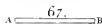
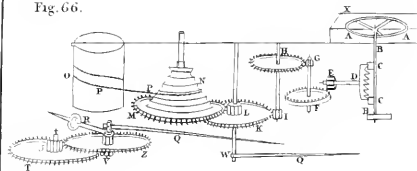

Fig. 66.



S E C T. VI.

HYDROSTATICS *and* PNEUMATICS.

D E F I N I T I O N I.

A Fluid, is such a body whose parts are easily moved among themselves, and yield to any force acting against them.

D E F. II.

Hydrostatics, is a science that demonstrates the properties of fluids.

D E F. III.

Hydraulics, is the art of raising water by engines.

D E F. IV.

Pneumatics, is that science which shews the properties of the air.

D E F. V.

A fountain or *jet d'eau*, is an artificial spout of water.

P R O P. LXIII.

If one part of a fluid be higher than another, the higher parts will continually descend to the lower places, and will not be at rest, till the surface of it is quite level.

For the parts of a fluid being movable every way, if any part is above the rest, it will descend by its own gravity as low as it can get. And afterwards other parts that are now become higher,

Fig. will descend as the other did, till at last they will all be reduced to a level or horizontal plane.

Cor. 1. Hence water that communicates by means of a channel or pipe, with other water; will settle at the same high in both places.

Cor. 2. For the same reason, if a fluid gravitates towards a center; it wil' dispose itself into a spherical figure, whose center is the center of force. As the sea in respect of the earth.

P R O P. LXIV.

If a fluid be at rest in a vessel whose base is parallel to the horizon; equal parts of the base are equally pressed by the fluid.

For upon every part of the base there is an equal column of the fluid supported by it. And as all these columns are of equal weight, they must press the base equally; or equal parts of the base will sustain an equal pressure.

Cor. 1. *All parts of the fluid press equally at the same depth.*

For imagine a plain drawn thro' the fluid parallel to the horizon. Then the pressure will be the same in any part of that plane, and therefore the parts of the fluid at the same depth sustain the same pressure.

Cor. 2. *The pressure of a fluid at any depth, is as the depth of the fluid.*

For the pressure is as the weight, and the weight is as the height of a column of the fluid.

P R O P. LXV.

If a fluid is compressed by its weight or otherwise ; at any point it presses equally, in all manner of directions.

This arises from the nature of fluidity ; which is, to yield to any force in any direction. If it cannot give way to any force applied, it will press against other parts of the fluid in direction of that force. And the pressure in all directions will be the same. For if any one was less, the fluid would move that way, till the pressure be equal every way.

Cor. In any vessel containing a fluid ; the pressure is the same against the bottom, as against the sides, or even upwards, at the same depth.

P R O P. LXVI.

The pressure of a fluid upon the base of the containing vessel, is as the base, and perpendicular altitude ; whatever be the figure of the vessel that contains it. 69.

Let ABIC, EGKH be two vessels. Then (Prop. LXIV. Cor. 2.) the pressure upon an inch on the base AB = height CD \times 1 inch. And the pressure upon an inch on the base HK is = height FH \times 1 inch. But (Prop. LXIV.) equal parts of the bases are equally pressed, therefore the pressure on the base AB is CD \times number of inches in AB ; and pressure on the base HK is FH \times number of inches in HK. That is, the pressure on AB is to the pressure on HK ; as base AB \times height CD, to the base HK \times height FH.

Cor. 1. Hence if the heights be equal, the pressures are as the bases. And if both the heights and bases be

Fig. equal; the pressures are equal in both; tho' their contents be never so different.

For the reason that the wider vessel EK, has no greater pressure at the bottom, is, because the oblique sides EH, GK, take off part of the weight. And in the narrower vessel CB, the sides CA, IB, re-act against the pressure of the water, which is all alike at the same depth; and by this re-action the pressure is increased at the bottom, so as to become the same every where.

Cor. 2. *The pressure against the base of any vessel, is the same as of a cylinder of an equal base and height.*

70. Cor. 3. *If there be a recurve tube ABF, in which are two different fluids CD, EF. Their heights in the two legs CD, EF, will be reciprocally as their specific gravities, when they are at rest.*

For if the fluid EF be twice or thrice as light as CD; it must have twice or thrice the height, to have an equal pressure, to counterbalance the other.

P R O P. LXVII.

71. *If a body of the same specific gravity of a fluid; be immersed in it, it will rest in any place of it. A body of greater density will sink; and one of a less density will swim.*

Let A, B, C be three bodies; whereof A is lighter bulk for bulk than the fluid; B is equal; and C heavier. The body B, being of the same density, or equal in weight as so much of the fluid; it will press the fluid under it just as much as if the space was filled with the fluid. The pressure then will be the same all around it, as if the fluid was there, and consequently there is no force to put it out of its place. But if the body be lighter,
the

the pressure of it downwards will be less than before; and less than in other places at the same depth; and consequently the lesser force will give way, and it will rise to the top. And if the body be heavier, the pressure downwards will be greater than before; and the greater pressure will prevail and carry it to the bottom. Fig. 71.

Cor. 1. *Hence if several bodies of different specific gravity be immersed in a fluid; the heaviest will get the lowest.*

For the heaviest are impelled with a greater force, and therefore will go fastest down.

Cor. 2. *A body immersed in a fluid, loses as much weight, as an equal quantity of the fluid weighs. And the fluid gains it.*

For if the body is of the same specific gravity as the fluid; then it will lose all its weight. And if it be lighter or heavier, there remains only the difference of the weights of the body and fluid, to move the body.

Cor. 3. *All bodies of equal magnitudes, lose equal weights in the same fluid. And bodies of different magnitudes lose weights proportional to the magnitudes.*

Cor. 4. *The weights lost in different fluids, by immersing the same body therein, are as the specific gravities of the fluids. And bodies of equal weight, lose weights in the same fluid, reciprocally as the specific gravities of the bodies.*

Cor. 5. *The weight of a body swimming in a fluid, is equal to the weight of as much of the fluid, as the immersed part of the body takes up.*

For the pressure underneath the swimming body is just the same as so much of the immersed fluid; and therefore the weights are the same.

Cor.

Fig. Cor. 6. Hence a body will sink deeper in a lighter
71. fluid than in a heavier.

Cor. 7. Hence appears the reason why we do not feel the whole weight of an immersed body, till it be drawn quite out of the water.

P R O P. LXVIII.

72. If a fluid runs thro' a pipe, so as to leave no vacuities; the velocity of the fluid in different parts of it, will be reciprocally as the transverse sections, in these parts.

Let AC, LB be the sections at A and L. And let the part of the fluid ACBL come to the place *acbl*. Then will the solid ACBL = solid *acbl*; take away the part *acBL* common to both; and we have AC*ca* = LB*bl*. But in equal solids the bases and heights are reciprocally proportional. But if D*f* be the axis of the pipe, the heights D*d*, F*f*, passed thro' in equal times, are as the velocities. Therefore, section AC : section LB :: velocity along F*f* : velocity along D*d*.

P R O P. LXIX.

73. If AD is a vessel of water or any other fluid; B a hole in the bottom or side. Then if the vessel be always kept full; in the time a heavy body falls thro' half the hight of the water above the hole AB, a cylinder of water will flow out of the hole, whose hight is AB, and base the area of the hole.

The pressure of the water against the hole B, by which the motion is generated, is equal to the weight of a column of water whose hight is AB, and base the area B (by Cor. 2. Prop. LXVI.). But equal forces generate equal motions; and since a cylinder

cylinder of water falling thro' $\frac{1}{2}$ AB by its gravity, acquires such a motion, as to pass thro' the whole hight AB in that time. Therefore in that time the water running out must acquire the same motion. And that the effluent water may have the same motion, a cylinder must run out whose length is AB; and then the space described by the water in that time will also be AB, for that space is the length of the cylinder run out. Therefore this is the quantity run out in that time.

Cor. 1. *The quantity run out in any time is equal to a cylinder or prism, whose length is the space described in that time by the velocity acquired by falling thro' half the hight, and whose base is the hole.*

For the length of the cylinder is as the time of running out.

Cor. 2. *The velocity a little without the hole, is greater than in the hole; and is nearly equal to the velocity of a body falling thro' the whole hight AB.*

For without the hole the stream is contracted by the water's converging from all sides to the center of the hole. And this makes the velocity greater in about the ratio of 1 to $\sqrt{2}$.

Cor. 3. *The water spouts out with the same velocity, whether it be downwards, or sideways, or upwards. And therefore if it be upwards, it ascends nearly to the hight of the water above the hole.*

Cor. 4. *The velocities and likewise the quantities of the spouting water, at different depths; will be as the square roots of the depths.*

SCHOLIUM.

From hence are derived the rules for the construction of fountains or jets. Let ABC be a reservoir of water, CDE a pipe coming from it, to bring

Fig. 74. bring water to the fountain which spouts up at E, to the height EF, near to the level of the reservoir AB. In order to have a fountain in perfection, the pipe CD must be wide, and covered with a thin plate at E with a hole in it, not above the fifth or sixth part of the diameter of the pipe CD. And this pipe must be curve having no angles. If the reservoir be 50 feet high, the diameter of the hole at E may be an inch, and the diameter of the pipe 6 inches. In general, the diameter of the hole E, ought to be as the square root of the height of the reservoir. When the water runs thro' a great length of pipe, the jet will not rise so high. A jet never rises to the full height of the reservoir; in a 5 feet jet it wants an inch, and it falls short by lengths which are as the squares of the heights; and smaller jets lose more. No jet will rise 300 feet high.

75. A small fountain is easily made by taking a strong bottle A, and filling it half full of water; cement a tube BI very close in it, going near the bottom of the bottle. Then blow in at the top B, to compress the air within; and the water will spout out at B. If a fountain be placed in the sunshine and made to play, it will shew all the colours of the rainbow, if a black cloth be placed beyond it.

A jet goes higher if it is not exactly perpendicular; for then the upper part of the jet falls to one side without resisting the column below. The resistance of the air will also destroy a deal of its motion, and hinder it from rising to the height of the reservoir. Also the friction of the tube of pipe of conduct has a great share in retarding the motion.

78. If there be an upright vessel as AF full of water, and several holes be made in the side as B, C, D: then the distances, the water will spout, upon the horizontal plane EL, will be as the square roots of the rectangles of the segments, ABE, ACE, and ADE. For the spaces will be as the velocities

velocities and times. But (Cor. 4.) the velocity of Fig. the water flowing out of B, will be as \sqrt{AB} , and 78.
 the time of its moving (which is the same as the time of its fall) will be (by Prop. XIII.) as \sqrt{BE} ; therefore the distance EH is as $\sqrt{AB \times BE}$; and the space EL as \sqrt{ACE} . And hence if two holes are made equidistant from top and bottom, they will project the water to the same distance, for if $AB = DE$, then $ABE = ADE$, which makes EH the same for both, and hence also it follows, that the projection from the middle point C will be furthest; for ACE is the greatest rectangle. These are the proportions of the distances; but for the absolute distances, it will be thus. The velocity thro' any hole B, will carry it thro' $2AB$ in the time of falling thro' AB; then to find how far it will move in the time of falling thro' BE. Since these times are as the square roots of the heights, it will be, $\sqrt{AB} : 2AB :: \sqrt{BE} : EH = 2AB \sqrt{\frac{BE}{AB}} = 2 \sqrt{ABE}$; and so the space $EL = 2 \sqrt{ACE}$. It is plain, these curves are parabolas. For the horizontal motion being uniform; EH will be as the time; that is, as \sqrt{BE} , or BE will be as EH^2 , which is the property of a parabola.

If there be a broad vessel ABDC full of water, and the top AB fits exactly into it; and if the small pipe FE of a great length be soldered close into the top, and if water be poured into the top of the pipe F, till it be full; it will raise a great weight laid upon the top, with the little quantity of water contained in the pipe; which weight will be nearly equal to a column of the fluid, whose base is the top AB; and height, that of the pipe EF. For the pressure of the water against the top AB, is equal to the weight of that column of water,

Fig. ter, by Prop. LXV. and Cor. And Prop. LXVI.
76. Cor. 2.

But here the tube must not be too small. For in capillary tubes the attraction of the glass will take off its gravity. If a very small tube be immersed with one end in a vessel of water, the water will rise in the tube above the surface of the water; and the higher, the smaller the tube is. But in quicksilver, it descends in the tube below the external surface, from the repulsion of the glass.

77. To explain the operation of a syphon, which is a crooked pipe CDE, to draw liquors off. Set the syphon with the ends C, E, upwards, and fill it with water at the end E till it run out at C; to prevent it, clap the finger at C, and fill the other end to the top, and stop that with the finger. Then keeping both ends stopt, invert the shorter end C into a vessel of water AB, and take off the fingers, and the water will run out at E, till it be as low as C in the vessel; provided the end E be always lower than C. Since E is always below C, the height of the column of water DE is greater than that of CD, and therefore DE must out weigh CD and descend, and CD will follow after, being forced up by the pressure of the air, which acts upon the surface of the water in the vessel AB.

The surface of the earth falls below the horizontal level only an inch in 620 yards; and in other distances the descents are as the squares of the distances.

79. And to find the nature of the curve DCG, forming the jet IDG. Let AK be the height or top of the reservoir HF, and suppose the stream to ascend without any friction, or resistance. By the laws of falling bodies the velocity in any place B, will be as \sqrt{AB} . Put the semidiameter of the hole at D = d , and AD = b . Then since the same water passes thro' the sections at D and B; therefore (Prop. LXVIII.) the velocity will be reciprocally

as

as the section; whence $\sqrt{b} : \frac{1}{dd} :: \sqrt{AB} : \frac{1}{BC^2}$; Fig. 79.

therefore $\frac{\sqrt{b}}{BC^2} = \frac{\sqrt{AB}}{dd}$, and $dd\sqrt{b} = BC^2\sqrt{AB}$,

whence $AB \times BC^4 = bd^4$; which is a paraboliform figure whose asymptote is AK, for the nature of the cataractic curve DCG. And if the fluid was to descend thro' a hole, as IC; it would form itself into the same figure GCD in descending.

P R O P. LXX.

The resistance any body meets with in moving thro' a fluid is as the square of the velocity.

For if any body moves with twice the velocity of another body equal to it, it will strike against twice as much of the fluid, and with twice the velocity; and therefore has four times the resistance; for that will be as the matter and velocity. And if it moves with thrice the velocity, it strikes against thrice as much of the fluid in the same time, with thrice the velocity, and therefore has nine times the resistance. And so on for all other velocities.

Cor. If a stream of water whose diameter is given, strike against an obstacle at rest; the force against it will be as the square of the velocity of the stream.

For the reason is the same; since with twice or thrice the velocity; twice or thrice as much of the fluid impinges upon it, in the same time.

P R O P. LXXI.

The force of a stream of water against any plane obstacle at rest, is equal to the weight of a column of water, whose base is the section of the stream; and hight, the space descended thro' by a falling body, to acquire that velocity.

For let there be a reservoir whose hight is that space fallen thro'. Then the water (by Cor. 2. Prop.

Fig. Prop. LXIX.) flowing out at the bottom of the reservoir, has the same motion as the stream; but this is generated by the weight of that column of water, which is the force producing it. And that same motion is destroyed by the obstacle, therefore the force against it is the very same: for there is required as much force to destroy as to generate any motion.

Cor. The force of a stream of water flowing out at a hole in the bottom of a reservoir, is equal to the weight of a column of the fluid of the same height and whose base is the hole.

P R O P. LXXII. *Prob.*

To find the specific gravity of solids or fluids.

1. *For a solid heavier than water.*

Weigh the body separately, first out of water, and then suspended in water. And divide the weight out of water by the difference of the weights, gives the specific gravity; reckoning the specific gravity of water 1.

For the difference of the weights is equal to the weight of as much water (by Cor. 2. Prop. LXVII.); and the weights of equal magnitudes, are as the specific gravities; therefore the difference of these weights; is to the weight of the body; as the specific gravity of water 1, to the specific gravity of the body.

2. *For a body lighter than water.*

Take a piece of any heavy body, so big as being tied to the light body, it may sink it in water. Weigh the heavy body in and out of water, and find the loss of weight. Also weigh the compound both in and out of water, and find also the loss of weight.

weight. Then divide the weight of the light body (out of water), by the difference of these losses, gives the specific gravity; the specific gravity of water being 1. Fig.

For the last loss is = weight of water equal in magnitude to the compound.

And the first loss is = weight of water equal in magnitude to the heavy body.

Whence the dif. losses is = weight of water equal in magnitude to the light body.

and the weights of equal magnitudes, being as the specific gravities; therefore the difference of the losses, (or the weight of water equal to the light body) : weight of the light body : : specific gravity of water 1 : specific gravity of the light body.

3. For a fluid of any sort.

Take a piece of a body whose specific gravity you know; weigh it both in and out of the fluid; take the difference of the weights, and multiply it by the specific gravity of the solid body, and divide the product by the weight of the body (out of water), for the specific gravity of the fluid.

For the difference of the weights in and out of water, is the weight of so much of the fluid as equals the magnitude of the body. And the weight of equal magnitudes being as the specific gravities; therefore, weight of the solid : difference of the weights (or the weight of so much of the fluid) : : specific gravity of the solid : to the specific gravity of the fluid.

Example.

I weighed a piece of lead ore, which was 124 grains; and in water it weighed 104 grains, the
K
difference

Fig. difference is 20; then $\frac{124}{20} = 6.2$; the specific gravity of the ore.

A table of specific gravities.

Fine gold	—	—	—	19.640
Standard gold	—	—	—	18.888
Quicksilver	—	—	—	14.000
Lead	—	—	—	11.340
Fine silver	—	—	—	11.092
Standard silver	—	—	—	10.536
Copper	—	—	—	9.000
Copper half-pence	—	—	—	8.915
Gun metal	—	—	—	8.784
Fine brass	—	—	—	8.350
Cast brass	—	—	—	8.100
Steel	—	—	—	7.850
Iron	—	—	—	7.644
Pewter	—	—	—	7.471
Tin	—	—	—	7.320
Cast iron	—	—	—	7.000
Lead ore	—	—	—	6.200
Copper ore	—	—	—	5.167
Lapis calaminaris	—	—	—	5.000
Lead stone	—	—	—	4.930
Antimony	—	—	—	4.000
Diamond	—	—	—	3.517
Island crystal	—	—	—	2.720
Stone, hard	—	—	—	2.700
Rock crystal	—	—	—	2.650
Glass	—	—	—	2.600
Flint	—	—	—	2.570
Common stone	—	—	—	2.500
Crystal	—	—	—	2.210
Brick	—	—	—	2.000
Earth	—	—	—	1.984
Horn	—	—	—	1.840

Ivory

Sect. VI. HYDROSTATICS.

131
Fig.

Ivory	—	—	—	1.820
Chalk	—	—	—	1.793
Allum	—	—	—	1.714
Clay	—	—	—	1.712
Oil of vitriol	—	—	—	1.700
Honey	—	—	—	1.450
Lignum vitæ	—	—	—	1.327
Treacle	—	—	—	1.290
Pitch	—	—	—	1.150
Rozin	—	—	—	1.100
Mohogany	—	—	—	1.063
Amber	—	—	—	1.040
Urine	—	—	—	1.032
Milk	—	—	—	1.031
Brazil	—	—	—	1.031
Box	—	—	—	1.030
Sea water	—	—	—	1.030
Ale	—	—	—	1.028
Vinegar	—	—	—	1.026
Tar	—	—	—	1.015
Common clear water	—	—	—	1.000
Bee wax	—	—	—	.955
Butter	—	—	—	.940
Linfeed oil	—	—	—	.932
Brandy	—	—	—	.927
Sallad oil	—	—	—	.913
Logwood	—	—	—	.913
Ice	—	—	—	.908
Oak	—	—	—	.830
Ash	—	—	—	.830
Elm	—	—	—	.820
Oil of turpentine	—	—	—	.810
Walnut tree	—	—	—	.650
Fir	—	—	—	.580
Cork	—	—	—	.238
New fallen snow	—	—	—	.086
Air	—	—	—	.0012

Fig. Cor. 1. *As the weight lost in a fluid, is to the absolute weight of the body; so is the specific gravity of the fluid, to the specific gravity of the body.*

Cor. 2. *Having the specific gravity of a body, and the weight of it; the solidity may be found thus; multiply the weight in pounds by $62 \frac{1}{2}$. They say as that product to 1; so is the weight of the body in pounds, to the content in feet. And having the content given, one may find the weight, by working backwards.*

For a cubic foot of water weighs $62 \frac{1}{2}$ lb. avoirdupoise; and therefore a cubic foot of the body weighs $62 \frac{1}{2} \times$ by the specific gravity of the body. Whence the weight of the body, divided by that product, gives the number of feet in it. Or as 1, to that product; so is the content, to the weight.

SCHOLIUM.

§0. The specific gravities of bodies may be found with a pair of scales; suspending the body in water, by a horse hair. - But there is an instrument for this purpose called the *Hydrostatical Balance*, the construction of which is thus. AB is the stand and pedestal, having at the top two cheeks of steel, on which the beam CD is suspended, which is like the beam of a pair of scales, and must play freely, and be it self exactly in equilibrio. To this belongs the glass bubble G, and the glass bucket H, and four other parts E, F, I, L. To these are loops fastened to hang them by. And the weights of all these are so adjusted, that $E = F +$ the bubble in water, or $= I +$ the bucket out of water, or $= I + L +$ the bucket in water. Whence $L =$ difference of the weights of the bucket in and out of water. And if you please you may have a weight K, so that $K +$ bubble in water $=$ bubble out of water; or else find it in grains.

grains. The piece L has a slit in it to slip it upon the shank of I. Fig. 80.

It is plain the weight K = weight of water as big as the bubble, or a water bubble.

Then to find the specific gravity of a solid.

Hang E at one end of the balance, and I and the bucket with the solid in it, at the other end; and find what weight is a balance to it.

Then slip L upon I, and immerge the bucket and solid in the water; and find again what weight balances it. Then the first weight divided by the difference of the weights, is the specific gravity of the body; that of water being 1.

For fluids.

Hang E at one end, and F with the bubble at the other; plunge the bubble into the fluid in the vessel MN. Then find the weight P which makes a balance. Then the specific gravity of the fluid is $= \frac{K + P}{K}$, when P is laid on F; or $= \frac{K - P}{K}$, when P is laid on E.

For E being equal to I + the bucket; the first weight found for a balance, is the weight of the solid. Again, E being equal to I + L + the bucket in water; the weight to balance that, is the weight of the solid in water; and the difference, is = to the weight of as much water. Therefore (Cor. 1.) the first weight divided by that difference, is the specific gravity of the body.

Again, since E is = to F + the bubble in water; therefore P is the difference of the weights, of the fluid and so much water; that is, P = difference of K and a fluid bubble; or P = fluid - K, when the fluid is heavier than water, or when P is laid on F. And therefore P = K - the fluid bubble,

Fig. bubble, when contrary. Whence the fluid bubble
 80. = $K \pm P$, for a heavier or lighter fluid. And the
 specific gravities being as the weights of these equal
 bubbles; specific gravity of water : specific gravi-
 ty of the fluid :: $K : K \pm P :: 1 : \frac{K \pm P}{K}$ the spe-
 cific gravity of the fluid. Where if P be 0, it is
 the same as that of water.

P R O P. LXXIII.

*The air is a heavy body, and gravitates on all parts
 of the surface of the earth.*

That the air is a fluid is very plain, as it yields
 to any the least force that is impressed upon it,
 without making any sensible resistance. But if it
 be moved briskly, by some very thin and light bo-
 dy, as a fan, or by a pair of bellows, we become
 very sensible of its motion against our hands or
 face, and likewise by its impelling or blowing away
 any light bodies, that lie in the way of its motion.
 Therefore the air being capable of moving other
 bodies by its impulse, must it self be a body; and
 must therefore be heavy like all other bodies, in
 proportion to the matter it contains; and will con-
 sequently press upon all bodies placed under it.
 And being a fluid, it will dilate and spread itself
 all over upon the earth: and like other fluids will
 gravitate upon, and press every where upon its sur-
 face. The gravity and pressure of the air is also
 evident from experiments. For (fig. 70.) if water,
 &c. be put into the tube ABF, and the air be
 drawn out of the end F by an air-pump, the water
 will ascend in the end F, and descend in the end
 A, by reason of the pressure at A, which was
 taken off or diminished at F. There are number-
 less experiments of th's sort. And tho' these pro-
 perties

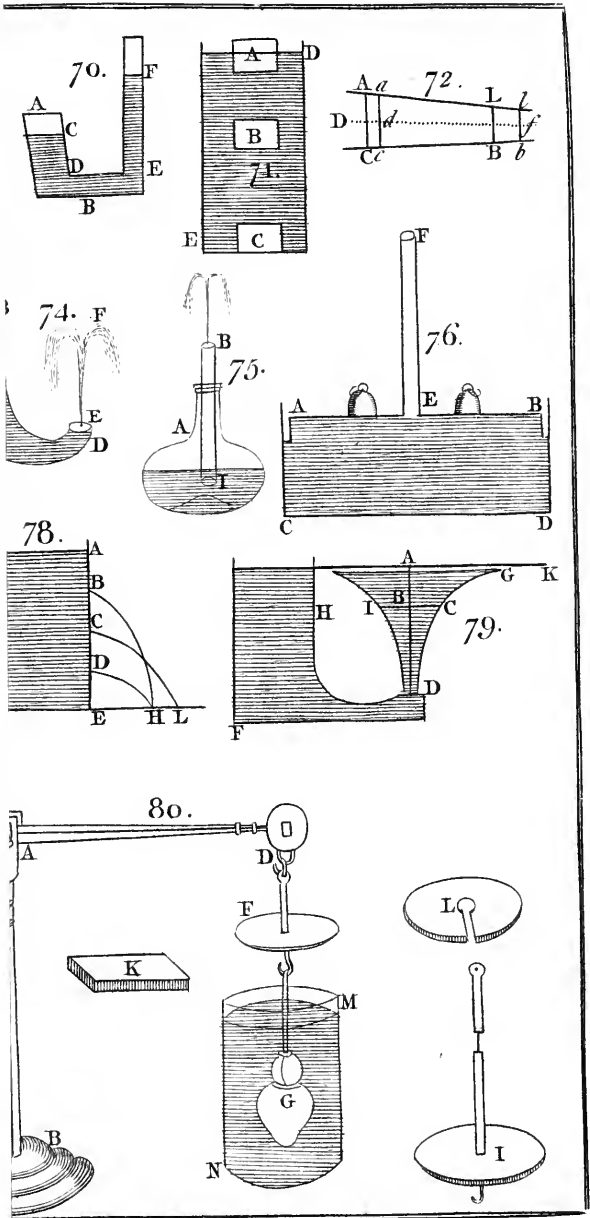

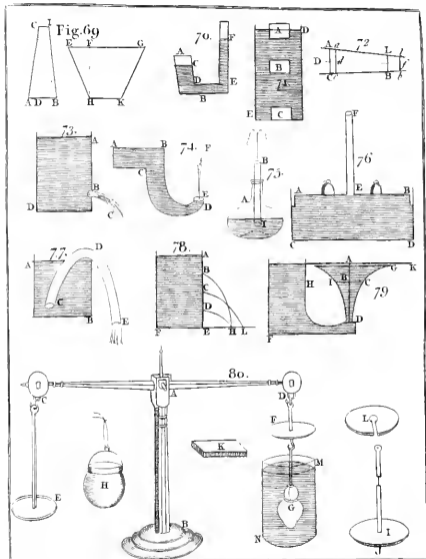

properties and effects are certain, yet the air is a fluid Fig. so very fine and subtle, as to be perfectly transpa- 70. rent, and quite invisible to the eye.

Cor. 1. *The air, like other fluids, will, by its weight and fluidity, insinuate itself into all the cavities, and corners within the earth; and there press with so much greater force, as the places are deeper.*

Cor. 2. *Hence the atmosphere, or the whole body of air surrounding the earth, gravitates upon the surfaces of all other bodies, whether solid or fluid, and that with a force proportional to its weight or quantity of matter.*

For this property it must have in common with all other fluids.

Cor. 3. *Hence the pressure, at any depth of water, or other fluid, will be equal to the pressure of the fluid together with the pressure of the atmosphere.*

Cor. 4. *Likewise all bodies, near the surface of the earth, lose so much of their weight, as the same bulk of so much air weight. And consequently, they are something lighter than they would be in a vacuum. But being so very small it is commonly neglected; tho' in strictness, the true or absolute weight is the weight in vacuo.*

P R O P. LXXIV.

The air is an elastic fluid, or such a one, as is capable of being condensed or expanded. And it observes this law, that its density is proportional to the force that compresses it.

These properties of the air, are proved by experiments, of which there are innumerable. If you take a syringe, and thrust the handle inwards, you'll feel the included air act strongly against your

Fig. hand; and the more you thrust, the further the piston goes in, but the more it resists; and taking away your hand, the handle returns back to where it was at first. This proves its elasticity, and also that air may be driven into a less space, and condensed.

75. Again, take a strong bottle, and fill it half full of water, and cement a pipe BI, close in it, going near the bottom; then inject air into the bottle thro' the pipe BI. Then the water will spout out at B, and form a jet; which proves, that the air is first condensed, and then by its spring drives out the water, till it become of the same density as at first, and then the spouting ceases.

81. Likewise if a vessel of glass AB be filled with water in the vessel CD, and then drawn up with the bottom upwards; if any air is left in the top at A, the higher you pull it up, the more it expands; and the further the glass is thrust down into the vessel CD, the more the air is condensed.

82. Again, take a crooked glass tube ABD open at the end A, and close at D; pour in mercury to the height BC, but no higher, and then the air in DC is in the same state as the external air. Then pour in more mercury at A, and observe where it rises to in both legs, as to G and H. Then you may always see that the higher the mercury is in the leg BH, the less the space GD is, into which the air is driven. And if the height of the mercury FH be such as to equal the pressure of the atmosphere, then DG will be half DC; if it be twice the pressure of the atmosphere, DG will be $\frac{1}{3}$ DC, &c. So that the density is always as the weight or compression. And here the part CD is supposed to be cylindrical.

Cor. 1. *The space that any quantity of air takes up, is reciprocally as the force that compresses it.*

Cor.

Cor. 2. *All the air near the earth is in a state of Fig. compression, by the weight of the incumbent atmosphere.*

Cor. 3. *The air is denser near the earth, or at the foot of a mountain, than at the top of it, and in high places. And the higher from the earth the more rare it is.*

Cor. 4. *The spring or elasticity of the air is equal to the weight of the atmosphere above it; and produces the same effects.*

For they always balance and sustain each other.

Cor. 5. *Hence if the density of the air be increased; its spring or elasticity will likewise be increased in the same proportion.*

Cor. 6. *From the gravity and pressure of the atmosphere, upon the surfaces of fluids, the fluids are made to rise in any pipes or vessels, when the pressure within is taken off.*

P R O P. LXXV.

The expansion and elasticity of the air is increased by heat, and decreased by cold. Or heat expands, and cold condenses the air.

This is also matter of experience; for tie a bladder very close with some air in it, and lay it before the fire, and it will visibly distend the bladder; and burst it if the heat is continued, and encreased high enough.

If a glass vessel AB (Fig. 81.) with water in it, 81.
be turned upside down, with a little air in the top A; and be placed in a vessel of water, and hung over the fire, and any weight laid upon it to keep it down; as the water warms, the air in the top A, will by degrees expand, till it fills the glass, and
by

Fig. by its elastic force, drive all the water out of the
 §1. glafs, and a good part of the air will follow, by
 continuing the vefsel there. Many more experi-
 ments may be produced proving the fame thing.

P R O P. LXXVI.

*The air will prefs upon the fufaces of all fluids,
 with any force; without paffing thro' them, or enter-
 ing into them.*

If this was not fo, no machine, whose ufe or
 action depends upon the preffure of the atmofphere,
 could do its bufinefs. Thus the weight of the at-
 mofphere preffes upon the furface of water, and
 forces it up into the barrel of a pump, without any
 air getting in, which would fpoil its working. Like-
 wife the preffure of the atmofphere keeps mercu-
 ry fufpended at fuch a hight, that its weight is equal
 to that preffure; and yet it never forces itfelf thro'
 the mercury into the vacuum above, though it
 ftand never fo long. And whatever be the texture
 or conftitution of that fubtle invifible fluid we call
 air, yet it is never found to pafs through any fluid,
 tho' it be made to prefs never fo ftroingly upon it.
 For tho' there be fome air inclofed in the pores of
 almoft all bodies, whether folid or fluid; yet the
 particles of air cannot by any force be made to pafs
 thro' the body of any fluid; or forced through the
 pores of it, although that force or preffure be con-
 tinued never fo long. And this feems to argue
 that the particles of air are greater than the parti-
 cles or pores of other fluids; or at leaft are of a
 ftructure quite different from any of them.

P R O P. LXXVII.

The weight or pressure of the atmosphere, upon any base at the earth's surface; is equal to the weight of a column of mercury of the same base, and whose height is from 28 to 31 inches, seldom more or less.

This is evident from the barometer, an instrument which shews the pressure of the air; which at some seasons stands at a height of 28 inches, sometimes at 29, and 30, or 31. The reason of this is not, because there is at some times more air in the atmosphere, than at others; but because the air being an extremely subtle and elastic fluid, capable of being moved by any impressions, and many miles high; it is much disturbed by winds, and by heat and cold; and being often in a tumultuous agitation; it happens to be accumulated in some places, and consequently depressed in others; by which means it becomes denser and heavier where it is higher, so as to raise the column of mercury to 30 or 31 inches. And where it is lower, it is rarer and lighter, so as only to raise it to 28 or 29 inches. And experience shews, that it seldom goes without the limits of 28 and 31.

Cor. 1. *The air in the same place does not always continue of the same weight; but is sometimes heavier, and sometimes lighter; but the mean weight of the atmosphere, is that when the quicksilver stands at about $29\frac{1}{2}$ inches.*

Cor. 2. *Hence the pressure of the atmosphere upon a square inch at the earth's surface, at a medium, is very near 15 pounds, averdupoise.*

For an inch of quicksilver weighs 8.102 ounces.

Cor. 3. *Hence also the weight or pressure of the atmosphere, in its lightest and heaviest state, is equal to*
the

Fig. *the weight of a column of water, 32 or 36 feet high; or at a medium 34 feet.*

For water and quicksilver are in weight nearly as 1 to 14.

Cor. 4. *If the air was of the same density to the top of the atmosphere, as it is at the earth; its height would be about $5\frac{1}{3}$ miles at a medium.*

For the weight of air and water are nearly as 12 to 1000.

Cor. 5. *The density of the air in two places distant from each other but a few miles, on the earth's surface and in the same level; may be looked on to be the same, at the same time.*

Cor. 6. *The density of the air at two different altitudes in the same place, differing only by a few feet; may be looked on as the same.*

Cor. 7. *If the perpendicular height of the top of a syphon from the water, be more than 34 feet, at a mean density of the air. The syphon cannot be made to run.*

For the weight of the water in the legs will be greater than the pressure of the atmosphere, and both columns will run down, till they be 34 feet high.

Cor. 8. *Hence also the quicksilver rises higher in the barometer, at the bottom of a mountain than at the top. And at the bottom of a coal pit, than at the top of it.*

SCHOLIUM.

Fig.

Hence the density of the air may be found at any hight from the earth, as in the following table.

Miles	density	Miles	density
$\frac{1}{4}$.9564	10	.1700
$\frac{1}{2}$.9146	20	.02917
$\frac{3}{4}$.8748	30	.005048
1	.8372	40	.000881
2	.7012	50	.000155
3	.5871	100	.0000000298
4	.4917		
5	.4119		

The first and third columns are the hight in miles from the surface of the earth. And the second and fourth columns, shew the density at that hight; supposing the density at the surface of the earth, to be 1.

The density at any hight is easily calculated by this series. Put $r =$ radius of the earth, $b =$ hight from the surface, both in feet. Then the density at the hight b , is the number belonging to the logarithm, denoted by this series $-\frac{b}{68444} -$

$\frac{b}{r} A - \frac{b}{r} B - \frac{b}{r} C$ &c. where $A, B, C,$ &c. are the preceding terms. The terms here will be alternately negative and affirmative. But the first term alone is sufficient when the hight is but a few miles.

By the weight and pressure of the atmosphere, the operations of pneumatic engines may be accounted for and explained. I shall just mention one or two.

A P U M P.

Fig. 83. is a common pump. AB the barrel or body of the pump, being a hollow cylinder, made of

83.

of

Fig. 83. of wood or lead. CD the handle movable about the pin E. DF an iron rod moving about a pin D; this rod is hooked to the bucket or sucker FG, which moves up and down within the pump. The bucket FG is hollow, and has a valve or clack L at the top opening upwards. H a plug fixed at the bottom of the barrel, being likewise hollow, and a valve at I opening also upwards. BK the bottom going into the well at K; the pipe below B need not be large, being only to convey the water out of the well into the body of the pump. The plug H must be fixed close that no water can get between it and the barrel; and the sucker FG, is to be armed with leather, to fit close that no air or water can get thro' between it and the barrel.

When the pump is first wrought, or any time in dry weather when the water above the sucker is wasted, it must be primed, by pouring in some water at the top A to cover the sucker, that no air get through. Then raising the end C of the handle, the bucket F descends, and the water will rise thro' the hollow GL, pressing open the valve L. Then putting down the end C raises the bucket F, and the valve L shuts by the weight of the water above it. And at the same time the pressure of the atmosphere forces the water up thro' the pipe KB, and opening the valve I, it passes thro' the plug into the body of the pump. And when the sucker G descends again, the valve I shuts, and the water cannot return, but opening the valve L, passes thro' the sucker GL. And when the sucker is raised again, the valve L shuts again, and the water is raised in the pump. So that by the motion of the piston up and down, and the alternate opening and shutting of the two valves; water is continually raised into the body of the pump, and discharged at the spout M.

The

The distance KG, from the well to the bucket, Fig. 83. must not be above 32 feet; for the pressure of the atmosphere will raise the water no higher, and if it is more, the pump will not work. It is evident a pump will work better when the atmosphere is heavy than when it is light, there being a twelfth or fifteenth part difference, at different times. And when it is lightest it is only equal to 32 feet. Wherefore the plug H must always be placed so low, as that the sucker GL may be within that compass.

A B A R O M E T E R.

Fig. 84. is a *Barometer*, or an instrument to measure the weight of the air. It consists of a glass cone ABC hollow within, filled full of mercury, and hermetically sealed at the end C, so that no air be left in it. When it is set upright, the mercury descends down the tube BC, into the bubble A, which has a little opening at the top A, that the air may have free ingress and egress. At the top of the tube C, there must be a perfect vacuum. This is fixed in a frame, and hung perpendicular against a wall. Near the top C, on the frame, is placed a scale of inches, shewing how high the mercury is in the tube BC, above the level of it in the bubble A, which is generally from 28 to 31 inches, but mostly about 29 or 30. Along with the scale of inches, there is also placed a scale of such weather as has been observed to answer the several heights of the quicksilver. Such a scale you have annexed to the 84th figure. In dividing the scale of inches, care must be taken to make proper allowance for the rising or falling of the quicksilver in the bubble A, which ought to be about half full, when it stands at $29\frac{1}{2}$, which is the mean height. For whilst the quicksilver rises an inch at C, it descends a little in the bubble A, and that descent

Fig. 84. descent must be deducted, which makes the divisions be something less than an inch. These inches must be divided into tenth parts, for the more exact measuring the weight of the atmosphere. For the pillar of mercury in the tube is always equal to the weight of a pillar of the atmosphere of the same thickness. And as the height of the quicksilver increases or decreases, the weight of the air increases or decreases accordingly. The tube must be near 3 feet long, and the bore not less than $\frac{2}{3}$ or $\frac{1}{6}$ of an inch, in diameter, or else the quicksilver will not move freely in it.

By help of the barometer, the height of mountains may be measured by the following table. In which the first column is the height of the mountain, &c. in feet or miles; the second the height of the quicksilver; and the third the descent of the quicksilver in the barometer; and this at a mean density of the air.

Feet	High Barom.	Defcent	Feet	High Barom.	Defcent.
0	29.500				
100	29.400	.100	2600	27.028	2.472
200	29.301	.199	2700	26.938	2.562
300	29.203	.297	2800	26.848	2.652
400	29.105	.395	2900	26.758	2.742
500	29.007	.493	3000	26.668	2.832
600	28.910	.590	3100	26.578	2.922
700	28.812	.688	3200	26.489	3.011
800	28.716	.784	3300	26.400	3.100
900	28.619	.881	3400	26.311	3.189
1000	28.523	.977	3500	26.222	3.278
1100	28.428	1.072	3600	26.136	3.364
1200	28.332	1.168	3700	26.049	3.451
1300	28.237	1.263	3800	25.961	3.539
1400	28.143	1.357	3900	25.874	3.626
1500	28.048	1.452	4000	25.786	3.714
1600	27.954	1.546	4100	25.699	3.801
1700	27.860	1.640	4200	25.613	3.887
1800	27.766	1.734	4300	25.527	3.973
1900	27.672	1.828	4400	25.441	4.059
2000	27.579	1.921	4500	25.355	4.145
2100	27.487	2.013	4600	25.270	4.230
2200	27.394	2.106	4700	25.185	4.315
2300	27.302	2.198	4800	25.101	4.399
2400	27.210	2.290	4900	25.017	4.483
2500	27.119	2.381	5000	24.933	4.567

The Table continued in MILES.

Miles	H. Barom.	Defcent	Miles	H. Barom.	Defcent
0.	29.50				
0.25	28.21	1.29	3.25	16.57	12.93
0.50	26.98	2.52	3.50	15.85	13.65
0.75	25.80	3.70	3.75	15.16	14.34
1.	24.70	4.80	4.	14.50	15.00
1.25	23.62	5.88	4.25	13.87	15.63
1.50	22.60	6.90	4.50	13.27	16.23
1.75	21.62	7.88	4.75	12.70	16.80
2.	20.68	8.82	5.	12.15	17.35
2.25	19.78	9.72	5.25	11.62	17.88
2.50	18.93	10.57	5.50	11.12	18.38
2.75	18.11	11.39	5.75	10.64	18.86
3.	17.32	12.18	6.	10.18	19.32

This table is made from a table of the air's density, made as in Schol. Prop. LXXVII. And then multiplying all the numbers thereof by 29.5 the mean density of the air. For the density of the air at any height above the earth is as the weight of the atmosphere above it, (by Prop. LXXIV.); and that is as the height of the mercury in the barometer.

A WATER BAROMETER.

85. A barometer may also be made of water as in fig. 85, which is a water barometer. AB is a glass tube open at both ends, and cemented close in the mouth of the bottle EF, and reaching very near the bottom. Then warming the bottle at the fire, part of the air will fly out; then the end A is put into a vessel of water mixed with cochineal, which will go thro' the pipe into the bottle as it grows cold. Then it is set upright; and the water may

may be made to stand at any point C, by sucking or blowing at A. And if this barometer be kept to the same degree of heat, by putting it in a vessel of sand, it will be very correct for taking small altitudes; for a little alteration in the weight of the atmosphere, will make the water at C rise or fall in the tube very sensibly. But if it be suffered to grow warmer, the water will rise too high in the tube, and spoil the use of it; so that it must be kept to the same temper.

If a barometer was to be made of water put into an exhausted tube, after the manner of quicksilver; it would require a tube 36 feet long or more; which could hardly find room within doors. But then it would go 14 times more exact than quicksilver; because for every inch the quicksilver rises, the water would rise 14; from whence every minute change in the atmosphere would be discernable.

And the water barometer above described will shew the variation of the air's gravity as minutely as the other, if the bottle be large to hold a great quantity of air. And in any case, by reducing the bottle (so far as the air is contained) to a cylinder; and put $D =$ diameter of the bottle, $d =$ diameter of the pipe, $p =$ height of air, $x =$ rising in the pipe, all in inches. Then the height of a

hill in feet will be nearly $1 + \frac{408dd}{pDD} \times 71x$. And if $y =$ height of the hill or any ascent, $Q = \frac{408dd}{pDD}$. Then $x = \frac{y}{1 + Q \times 71}$ very near, at a mean density of the air.

A T H E R M O M E T E R.

Fig. 86. is a *thermometer*, or an instrument to measure the degrees of heat and cold. AB is a hollow

Fig. hollow tube near two foot long, with a ball at the
 86. bottom; it is filled with spirits of wine mixed with cochineal, half way up the neck; which done, it is heated very much, till the liquor fill the tube, and then it is sealed hermetically at the end A. Then the spirit contracts within the tube as it cools. It is inclosed in a frame, which is graduated into degrees, for heat and cold. For hot weather dilates the spirit, and makes it run further up the tube; and cold weather on the contrary, contracts it, and makes it sink lower in the tube. And the particular divisions, shew the several degrees of heat and cold; against the principal of which, the words heat, cold, temperate, &c. are written.

They that would see more machines described, may consult my large book of Mechanics, where he will meet with great variety.

F I N I S.

E R R A T U M.

Page 35, Line 10 from the bottom, *read*, Cor. 1. Hence

A

M



to end.

Fig. 81.

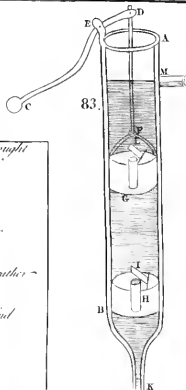
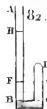
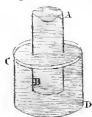

84.

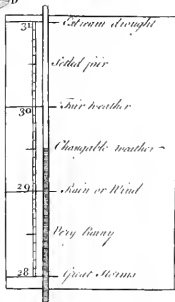

85.



86.

very hot
 hot
 warm
 temperate
 cold
 colder
 very cold

THE
PROJECTION
OF THE
SPHERE,
ORTHOGRAPHIC, STEREOGRAPHIC,
and GNOMONICAL.

Both demonstrating the

PRINCIPLES,

And explaining the

PRACTICE

Of these three several Sorts of
PROJECTION.

The SECOND EDITION,
Corrected and Improved.

In Minimis Usus——

L O N D O N,
Printed for J. NOURSE, in the Strand,
Bookfeller in Ordinary to His MAJESTY.

M DCC LXIX.

T H E
P R E F A C E.

*T*H E Projection of the Sphere, or of its Circles, has the same relation to Spherical Trigonometry, that practical Geometry has to plane Trigonometry. For as the one saves a deal of Calculation, by drawing a few right Lines, so does the other by drawing a few Circles. The Projection of the Sphere gives a Learner a good Idea of the Sphere and all its Circles, and of their several Positions to one another, and consequently of Spherical Triangles, and the Nature of Spherical Trigonometry.

I have here delivered the Principles of three sorts of Projection, in a small compass; and yet the Reader will find here, all that is essential to the subject; and yet nothing superfluous; for I think no more need be said, or indeed can be said about it, to make it intelligible and practicable. For here is laid down, not only the whole Theory, but the Practice likewise. Yet the practical Part is entirely disengaged from the Theory; so that any body (tho' he has no desire or leisure to attain to the Theory,) may nevertheless, by help of the Problems, make himself Master of the Practice. For which end I have endeavoured to make all the rules relating to practice, plain, short, and easy, and at the same time full and clear.

It is true the solution of Problems this way, must be allowed to be imperfect; for there will always be some errors in working, as well as in the instruments

we work with. But nobody in seeking an accurate solution to a Problem, will trust to a Projection by scale and compass; because this cannot be depended on in cases of great nicety. Yet where no great exactness is required it will be found very ready and useful; and, besides, will serve to prove and confirm the solution obtained by Calculation.

But then this defect is abundantly recompensed by the easiness of this method. For by scale and compass only, all sorts of Problems belonging to the Sphere, as in Astronomy, Geography, Dialling, &c. may be solved with very little trouble, which require a great deal of time and pains, to work out trigonometrically by the tables. It likewise affords a great pleasure to the mind, that one can, in a little time, describe the whole furniture of Heaven, and Earth, and represent them to the eye, in a small scheme of paper.

But its principal use is for such persons (and that is by far the greater number) as having no opportunity for learning Spherical Trigonometry, have yet a desire to resolve some Problems of the Sphere. For such as these, this small Treatise will be of particular service, because the practical rules, especially of any one sort of Projection, may be learned in a very little time, and are easily remembered. So that I have some hopes I shall please all my Readers, whether theoretical or practical.

W. E.

THE
 P R O J E C T I O N
 O F T H E
 S P H E R E I N P L A N O.

D E F I N I T I O N S.

1. *P*ROJECTION of the sphere is the representing its surface upon a plane, called the *Plane of Projection*.

2. *Orthographic* Projection, is the drawing the circles of the sphere upon the plane of some great circle, by lines perpendicular to that plane, let fall from all the points of the circles to be projected.

3. The *Stereographic* Projection, is the drawing the circles of the sphere upon the plane of one of its great circles, by lines drawn from the pole of that great circle to all the points of the circles to be projected.

4. The *Gnomonical* Projection, is the drawing the circles of an hemisphere, upon a plane touching it in the vertex, by lines or rays issuing from the center of the hemisphere, to all the points of the circles to be projected.

5. The *Primitive* circle is that on whose plane the sphere is projected. And the pole of this circle is called the *Pole* of Projection. The point from whence the *projecting* right lines issue is the *projecting Point*.

6. The *Line of Measures* of any circle is the common interfection of the plane of projection, and another plane that passes thro' the eye, and is perpendicular both to the plane of projection, and to the plane of that circle.

SCHOLIUM.

There are other Projections of the Sphere, as the *Cylindrical*, the *Scenographic* which belongs to Perspective, the *Globical* which belongs to Geography, *Mercators*, for which see Navigation, &c.

A X I O M.

The *Place* of any visible point of the Sphere upon the plane of projection, is where the projecting line cuts that plane.

Cor. *If the eye be applied to the projecting point, it will view all the circles of the Sphere, and every part of them, in the projection, just as they appear from thence in the Sphere itself.*

SCHOLIUM.

The Projection of the Sphere is only the shadow of the circles of the Sphere upon the plane of Projection, the light being in the place of the eye or projecting point.

The Signification of some Characters.

- + added to.
- subtracting the following quantity.
- < an angle.
- = equal to.
- ⊥ perpendicular to.
- ∥ parallel to.
- : : a proportion.

S E C T. I.

The Orthographic Projection of the
S P H E R E.

P R O P. I.

IF a right line *AB* is projected upon a plane, it is *Fig.*
projected into a right line; and its length will be to *3.*
the length of the projection, as radius to the cosine of
its inclination above that plane.

For let fall the perpendiculars *Aa*, *Bb* upon the plane of projection, then *ab* will be the line it is projected into; but by trigonometry *AB* : is to *Ao* or *ab* :: as radius : to the sine of *B* or cosine of *oAB*.

Cor. 1. If a right line is projected upon a plane, parallel thereto, it is projected into a right line parallel and equal to itself.

Cor. 2. If an angle be projected upon a plane which is parallel to the two lines forming the angle; it is projected into an angle equal to itself.

Cor. 3. Any plain figure projected upon a plane parallel to itself, is projected into a figure similar and equal to itself.

Cor. 4. Hence also the area of any plain figure, is to the area of its projection :: as radius, to the cosine of its elevation or inclination.

P R O P. II.

A circle perpendicular to the plane of projection, is projected into a right line equal to its diameter.

For projecting lines drawn through all the points of the circle fall in the common section of the planes

4 ORTHOGRAPHIC PROJECTION

Fig. of the circle and of projection, which is a right line (Geom. V. 3.), and equal to the diameter of the circle; because the planes intersect in that diameter. *Q. E. D.*

Cor. Hence any plane figure, perpendicular to the plane of projection is projected into a right line. For the perpendiculars from every point, will all fall in the common intersection of the figure with the plane of projection.

P R O P. III.

1. *A circle parallel to the plane of projection is projected into a circle equal to itself, and concentric with the primitive.*

Let BOD be the circle, I its center, C the center of the sphere, the points I, B, O, D, are projected into the points C, L, F, G. And therefore OICF, and BICL are rectangled parallelograms. Consequently $LC = BI = OI = FC$, (Geom. III. 1.). *Q. E. D.*

Cor. The radius CL or CF is the cosine of the circle's distance from the primitive, for it is the sine of AB.

P R O P. IV.

2. *An inclined circle is projected into an ellipsis whose transverse axis is the diameter of the circle.*

Let ADBH be the inclined circle, P its center; and let it be projected into *adb*; draw the plane ABFCa through the center C of the sphere, perpendicular to the plane of the given circle and plane of projection, to intersect them in the lines AB, *ab*; draw GPH, DE, perpendicular, and DQ parallel to AB; then because the line GP, and the plane of projection are both perpendicular to the

the plane ABF; therefore GH is parallel to the Fig. plane of projection, and therefore to *gb*.

In the circle ADB, $DQ^2 = GQH = gqb$, and $BP^2 = GP^2 = gp^2$. And (Geom. V. 12.) $BP : EP$ or $DQ :: bp : ep$ or dq , and $BP^2 : DQ^2 :: bp^2 : dq^2$; that is, $gp^2 : gqb :: bp^2 : dq^2$; and therefore *agbb* is an ellipsis, whose transverse *gb* is the diameter of the circle. Q. E. D.

Cor. 1. Since *ab* is perpendicular to *gb*, therefore *ab* is the conjugate axis; and is twice the sine of the \angle *ABb* to the radius *gp*; that is, the conjugate axis is equal to twice the cosine of the inclination, to the radius of the circle.

Cor. 2. The transverse axis is equal to twice the cosine of its distance from its parallel great circle. For $gb = GH = 2AP =$ twice the sine of *AK*.

Cor. 3. The extremities of the conjugate axis are distant from the center of the primitive, by the sines of the circles nearest and greatest distance from the pole of the primitive. Thus *aC* is the sine of *AN*, and *bC* the sine of *BN*.

Cor. 4. Hence also it is plain that the conjugate axis always passes thro' the center *C* of the primitive; and is always in the line of measures of that circle.

SCHOLIUM.

Every circle in the projection represents two equal 3: circles, parallel and equidistant from the primitive. Every right line represents two semicircles, one towards the eye, the other in the opposite side. Every ellipsis represents two equal circles, but contrarily inclined as *AB*, *CD*; one above the primitive the other below it.

And now the Theory being laid down, it remains only to deduce thence, some short rules for practice, as follows.

Fig.

P R O P. V. *Prob.*

5. *To project a circle parallel to the primitive.*

Rule.

Take the complement of its distance from the primitive, and set it from A to E; and with the center C and radius $CD =$ perpendicular EF, describe the circle DgG.

By the plain scale.

Take the sine of its distance from the pole of the primitive; with that radius and the center C describe the circle.

P R O P. VI. *Prob.*

4. *To project a right circle, or one that is perpendicular to the plain of projection.*

Rule.

Thro' the center C of the primitive, draw the diameter AB, and take the distance from its parallel great circle, and set from A to E, and from B to D, and draw ED, the right circle required.

By the scale.

Take the sine of the circle's distance from its parallel great circle AB, and at that distance draw a parallel ED for the circle required.

P R O P. VII. *Prob.*

To project a given oblique circle.

Rule.

6. Draw the line of measures AB, and take the circle's nearest distance from the primitive, and set from

from B to D, upwards if it be above the primitive; Fig. 6.
 or downward, if below; likewise take its greatest
 distance, and set from A to E, and draw ED, and
 let fall the perpendiculars EF, DG; and bisect FG
 in H, and erect the perpendicular KHI, making
 $KH = HI = \text{half } ED$; then describe an ellipsis
 (by the Conic Sections) whose transverse is IK and
 conjugate FG; and that shall represent the circle
 given.

By the scale.

Draw the line of measures AB; and take the 6.
 sines of the circle's nearest and greatest distance
 from the pole of the primitive, and set them from
 the center C to F and G, (both ways if the circle
 encompass the pole, but the same way if it lie on
 one side the pole;) bisect FG in H, and erect HK,
 HI perpendicular to FG, and $=$ to the radius of
 the circle given, or the sine of its distance from its
 own pole; about the axes FG, KI describe an el-
 lipsis, and it is done.

SCHOLIUM.

An ellipsis great or small may be described by 10.
 points, thus; thro' the center D of the circle and
 ellipsis, draw BD \perp the transverse AR; and on
 AR erect a sufficient number of perpendiculars IK,
 ik &c. and make as DB or DA : DE :: IK : IF ::
 ik : if &c. then thro' all the points E, F, f, &c.
 draw a curve. See Prop. 76. ellipsis.

P R O P. VIII. Prob.

To find the pole of a given ellipsis.

Rule.

Thro' the center of the primitive C, draw the 7.
 conjugate of the ellipsis; on the extreme points
 F, G, erect the perpendiculars FE, GD, or set the
 transverse

8 ORTHOGRAPHIC PROJECTION

Fig. transverse IK from E to D, and bisect ED in R;
 7. and let fall RP perpendicular to AB, then is P
 the pole.

By the scale.

7. Take CF, and CG, and apply to the fines, and
 find the degrees answering or the supplements;
 then take the sine of half the sum of these degrees,
 if F, G be both on one side of C, or the sine of
 half the difference, if they lie on contrary sides;
 and set it from C to the pole P.

Or thus; apply the semi-transverse IH to the
 fines, and set the degrees from E to R; and draw
 RP \perp to AB; and P is the pole.

P R O P. IX. *Prob.*

*To measure an arch of a parallel circle; or to set
 any number of degrees on it.*

Rule.

With the radius of the parallel, and one foot
 in C describe a circle Gg, draw CGB, and Cgb;
 then Bb will measure the given arch Gg; or Gg
 will contain the given number of degrees set from
 B to b. So that either being given finds the other.

P R O P. X. *Prob.*

To measure any part of a right circle.

Rule.

8. In the right circle ED, let EA = AD; and
 let AB be to be measured. Make CF = AE;
 with extent BA = FG describe the arch GI; draw
 CGK to touch it in G; then is HK the measure of
 AB. For FG = S. \angle HCK to the radius CF or
 AE, and BA is the same, by Cor. Prop. III.

Other

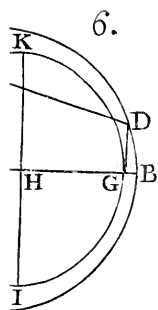

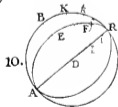
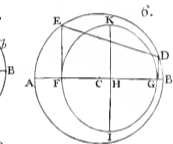
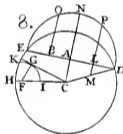
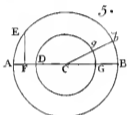
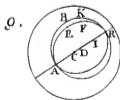
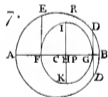
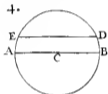
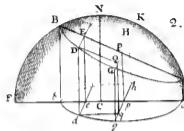
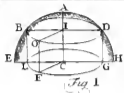

Otherwise thus.

On the diameter ED, describe the semicircle END, draw AN, BO, LP perpendicular to ED, then ON is the measure of BA, and NP of AL; and ON or NP may be measured as in Prop. IX.

By the scale.

Let AL be to be measured. Draw CD; and LM parallel to AC, then CM applied to the lines gives the degrees. For radius CD : AD :: CM : AL.

Cor. If the right circle passes thro' the center, there is no more to do, but to raise perpendiculars on it, which will cut the primitive, as required. Or apply the part of the right circle to the line of sines.

P R O P. XI. *Prob.*

To set off any number of degrees upon a right circle, DE.

Rule.

Draw CA + DE, and make the \angle HCK = the degrees given, make CF = radius AE, take FG the nearest distance, and set from A to B; then AB = \angle HCK, the degrees proposed. 8.

Otherwise thus.

On ED describe the semicircle END, then by Prop. IX. set off NP = degrees given, draw PL perpendicular to ED, then AL contains the degrees required.

Or thus by the scale.

Draw CD, take the given degrees of the lines, and set from C to M, and draw ML parallel to CA, then AL = arch required.

P R O P.

Fig.

P R O P. XII. *Prob.*

9. *To measure an arch of an ellipsis; or to set any*
 10. *number of degrees upon it.*

Rule.

About AR the transverse axis of the ellipsis, describe a circle ABR; erect the perpendiculars BED, KFI, on AR; then BK is the measure of EF, or EF is the representation of the arch BK. And BK is to be measured, or any degrees set upon it, as in Prop. IX.

S C H O L I U M.

These Problems are all evident from the three first propositions, and need no other demonstration. If the sphere be projected on any plane parallel to the primitive, the projection will be the very same; for being effected by parallel lines, which are always at the same distance, there will be produced the same figure, or representation. Of all orthographic projections, those on the meridian or on the solstitial colure, commonly called the Analemma, is most useful; because a great many of the circles of the sphere fall into right lines or circles, whereas in the projections upon other planes, they are projected into ellipses, which are hard to describe; which makes these sorts of projection to be neglected.

And by the same rules that the circles of the sphere are projected upon a plane, any other figure may likewise be orthographically projected; by letting fall perpendiculars upon the plane from all the angles, or all the points of the figure, and joining these points with right or curve lines, as they are in the figure itself.

By this kind of projection, either the convex or concave side of the sphere, may be projected; which

which is peculiar to this sort of projection; that Fig. 9. is, either the hemisphere towards you, or that from you, may be projected upon the plane of its great circle. And since in some cases they both have the same appearance, it ought to be mentioned whether it is.

But if both the convex and concave sides of the *same hemisphere* be projected; that is, if you make two projections, one for the convex, the other for the concave side; the circles in one will be inverted in respect of the other, the right to the left, &c. Because in looking at the same hemisphere, it will not have the same appearance, when you look at the contrary sides of it; because you look contrary ways at it, to see the external and internal surfaces.

Fig.

S E C T. II.

The Stereographic Projection of the
S P H E R E.

P R O P. I.

ANY circle passing thro' the projecting point, is projected into a right line.

For all lines drawn from the projecting point, to this circle, pass thro' the intersection of this circle and plane of projection, which is a right line.

Cor. 1. *A great circle passing thro' the poles of the primitive is projected into a right line passing thro' the center.*

Cor. 2. *Any circle passing thro' the projecting point is projected into a right line perpendicular to the line of measures, and distant from the center, the semitangent of its nearest distance from the pole opposite to*
12. *the projecting point. Thus the circle AE is projected into a right line passing thro' G, and perpendicular to BC, the line of measures, and GC is the semitangent of EM.*

P R O P. II.

Every circle (that passes not through the projecting point) is projected into a circle.

11. *Case I.* Let the circle EF be parallel to the primitive BD; lines drawn to all points of it from the projecting point A, will form a conic surface, which being cut parallel to the base by the plane BD, the section GH (into which EF is projected) will be a circle by the conic sections.

Case

Case II. Let BH be the line of measures to the circle EF, draw FK parallel to BD, then arch AK = AF, and therefore $\angle AFK$ or $\angle AHG = \angle AEF$; therefore in the triangles AEF, AGH, the angles at E and H are equal, and the angle A common; therefore the angles at F and G are equal. Therefore the cone of rays AEF (whose base EF is a circle) is cut by subcontrary section, by the plane of projection BD, and therefore, by the conic sections, the section GH (which is the projection of the circle EF) will also be a circle. Q. E. D.

Cor. When AF is equal to AG, the circle EF is projected into a circle equal to it self.

For then the similar triangles AHG and AEF, will also be equal, and $GH = EF$.

P R O P. III.

Any point on the sphere's surface is projected into a point, distant from the center, the semi-tangent of its distance from the pole opposite to the projecting point.

Thus the point E is projected into G, and F into H; and CG is the semi-tangent of EM, and CH of MF.

Cor. 1 A great circle perpendicular to the primitive is projected into a line of semi-tangents passing thro' the center, and produced infinitely.

For MF is projected into CH its semi-tangent, and EM into the semi-tangent CG.

Cor. 2. Any arch EM of a great circle perp. to the primitive; is projected into the semi-tangent of it.

Thus EM is projected into GC.

Cor. 3. Any arch EMF of a great circle is projected into the sum of its semi-tangents, of its greatest

B

and

Fig. and least distances from the opposite pole M , if it lie
 12. on both sides of M , or the dif. of the semi-tangents,
 when all on one side.

P R O P. IV.

13. *The angle made by two circles on the surface of the sphere is equal to that made by their representatives upon the plane of projection.*

Let the angle BPK be projected. Thro' the angular point P and the center C , draw the plane of a great circle PED perpendicular to the plane of projection EFG . Let a plane PHG touch the sphere in P ; then since the circle EPD is perpendicular both to this plane and to the plane of projection, therefore it is perpendicular to their intersection GH . The angles made by circles are the same as those made by their tangents, therefore in the plane PGH , draw the tangents PH , PF , PG to the arches, PB , PD , PK ; and these will be projected into the lines pH , pF , pK : Now I say the $\angle HPG = \angle HpG$. For the angle $CPF =$ a right angle $= CPA + CAP$; therefore taking away the equal angles CPA and CAP , and $\angle pPF = CPA$ or PpF ; consequently $pF = PF$. Therefore in the right angled triangles PFG and pFG , there are two sides equal and the included \angle right; therefore hypotenuse $PG = pG$. And for the same reason in the right angled triangles PFH and pFH , $PH = pH$. Lastly in the triangles PHG and pHG , all the sides are respectively equal, and therefore $\angle P = \angle p$. Q. E. D.

Cor. 1. *The rumb lines projected make the same angles with the meridians as upon the globe; and therefore are logarithmic spirals on the plain of the equinoctial. For every part of the rumb coincides with some great circle.*

Cor.

Cor. 2. *The angle made by two circles on the sphere Fig. is equal to the angle made by the radii of their projections at the point of intersection. For the angle made by two circles on a plane is the same with that made by their radii drawn to the point of intersection.*

P R O P. V.

The center of a projected (lesser) circle perpendicular to the primitive, is in the line of measures distant from the center of the primitive, the secant of the lesser circles distance from its own pole; and its radius is the tangent of that distance.

Let A be the projecting point, EF the circle to be projected, GH the projected diameter. From the centers C, D draw CF, DF, and the triangles CFI, DFI are right angled at I; then $\angle IFC = \angle FCA = 2\angle FEA$ or $2\angle FEG = 2\angle FHG = \angle FDG$, therefore $\angle IFC + \angle IFD = \angle FDG + \angle IFD =$ a right angle; that is CFD is a right angle, and the line CD is the secant of BF, and the radius FD is the tangent of it. Q. E. D. 14.

Cor. *If these circles be actually described, 'tis plain the radius FD is a tangent to the primitive at F, where the lesser circle cuts it.*

P R O P. VI.

The center of Projection of a great circle is in the line of measures, distant from the center of the primitive, the tangent of its inclination to the primitive; and its radius is the secant of its inclination.

Let A be the projecting point, EF the great circle, GH the projected diameter, D the center; B 2 draw 15.

Fig. draw DA. The angle EAF being in a semicircle is right. In the right angled triangle GAH, AC is perpendicular to GH, therefore $\angle GAC = \angle AHC$ and their double, $\angle E\hat{C}B = \angle ADC$, and their complements. $\angle ECF = \angle CAD$. Therefore CD is the tangent of $\angle ECI$, and radius AD its secant. Q. E. D.

16. Cor. 1. *If the great oblique circle AGBH be actually described upon the primitive AIB. I say, all great circles passing thro' G will have the centers of their projections in the line RS drawn thro' the center D, perpendicular to the line of measures IH.*

For since all great circles cut one another at a semicircle's distance, all circles passing thro' G must cut at the opposite point H; and therefore their centers must be in the Line RDS.

Cor. 2. *Hence also if any oblique circle GLH be required to make any given angle with another circle BGAH, it will be projected the same way with regard to GAH considered as a primitive, and RS its line of measures; as the circle BGA is on the primitive BIA, and line of measures ID. And therefore the tangent of the angle AGL to the radius GD, set from D to N, gives the center of GL.*

For the $\angle NGD$ will then be equal to $\angle AGL$, by Cor. 2. Prop. IV. and therefore GLH is rightly projected.

Cor. 3. *And for the same reason, if N be the center of the circle GgHR; the centers of all circles passing thro' g and R, will be in the line rNs perpendicular to RS; so n is the center of grR. But then as g, R do not represent opposite points of the circle GgH, therefore all circles passing thro' g, R, (as grR) will be lesser circles, except GgiHR.*

12.

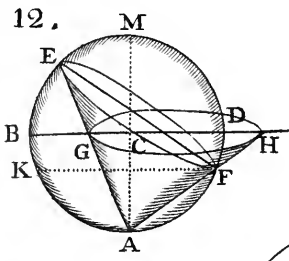

14.

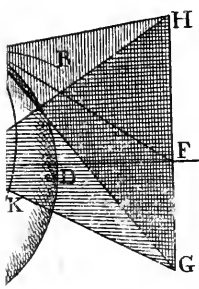
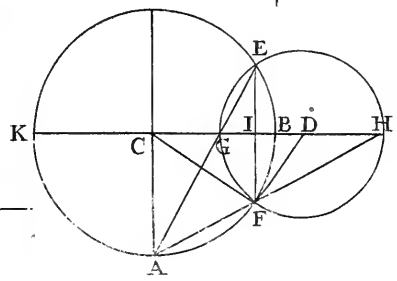

16.

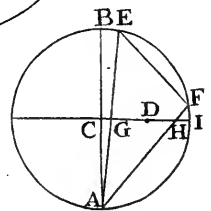
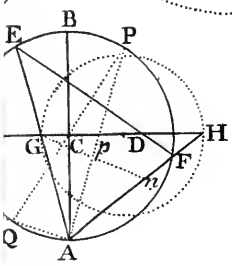
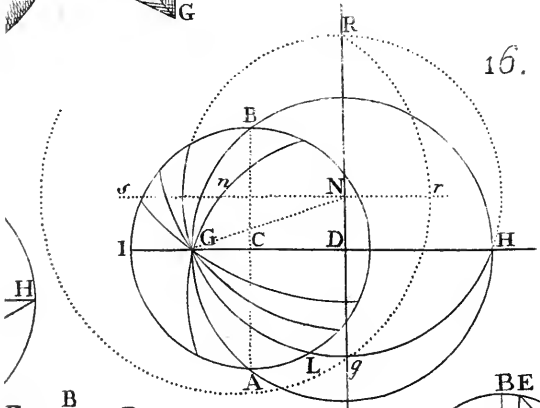

18.

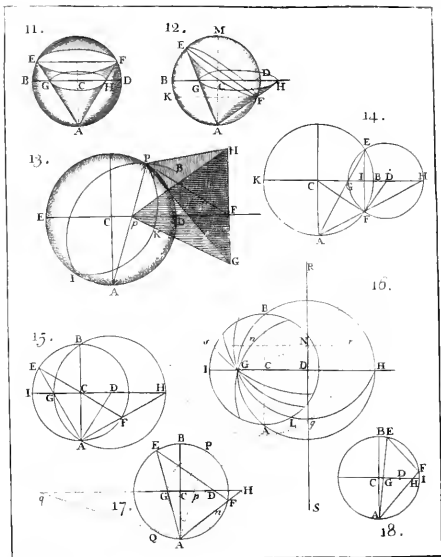

S C H O L I U M.

Fig.
16.

Of all great circles in the projection, the primitive is the least. For the radius of any oblique great circle (being the secant of the inclination) is greater than the radius of the primitive; as the secant is always greater than the radius. Therefore every oblique great circle in the projection is greater than the primitive.

P R O P. VII.

The projected extremities of the diameter of any circle, are in the line of measures, distant from the center of the primitive circle, the semi-tangents of its nearest and greatest distances from the pole of projection opposite to the projecting point.

For the diameter of the circle EF is projected 15. into GH, from the projecting point A. But GC 17. is the semi-tangent of EB, and CH the semi-tangent of BF. Q. E. D.

Cor. 1. *The points where an inclined great circle 15. cuts the line of measures, within and without the primitive, is distant from the center of the primitive, the tangent and co-tangent of half the complement of the circle's inclination to the primitive.*

For CG = tangent of half EB, or of half the complement of IE the inclination. And (because the $\angle EAF$ is right) CH is the co-tangent of GAC or half EB.

Cor. 2. *Hence the center D of a projected circle is 17. in the line of measures distant, from the center of the 18. primitive, half the difference of the semi-tangents of its nearest and greatest distance from the opposite pole, if it encompasses that pole; but half the sum of the semi-tangents if it lie on one side the pole of projection.*

Fig. Cor. 3. *And the radius is half the sum of the semi-tangents, if the circle encompasses the pole; or half the difference if it lyes on one side.*

17. Cor. 4. *Hence also if pq be the projected poles, it will be $qG : pG :: qH : pH$.*

For draw Gn parallel to qA , and since P, Q are the poles, therefore qAp is a right angle, and since the angles GAp and pAH are equal, and Gn perpendicular to Ap , therefore $GA = An$; whence by similar triangles $qG : qH :: An$ or $AG : AH :: Gp, pH$, (Geom. II 25.) And consequently the line qH is cut harmonically in the points G, p .

P R O P. VIII.

The projected poles of any circle are in the line of measures, within and without the primitive, and distant from its center the tangent and co-tangent of half its inclination to the primitive.

19. The poles P, p of the circle EF are projected into D and d ; and CD is the tangent of CAD or half BCP , that is, of half GCI , the inclination of the circle ICK , parallel to EF . Likewise Cd is the tangent of CAd , or the co-tangent of CAD .

Q. E. D.

Cor. 1. *The pole of the primitive is its center; and the pole of a right circle is in the primitive.*

19. Cor. 2. *The projected center of any circle is always between the projected pole (nearest to it on the sphere) and the center of the primitive; and the projected centers of all circles lye between the projected poles.*

For the middle point of EF or its center is projected into S ; and all the points in Pp (in which are all the centers) are projected into Dd .

Cor.

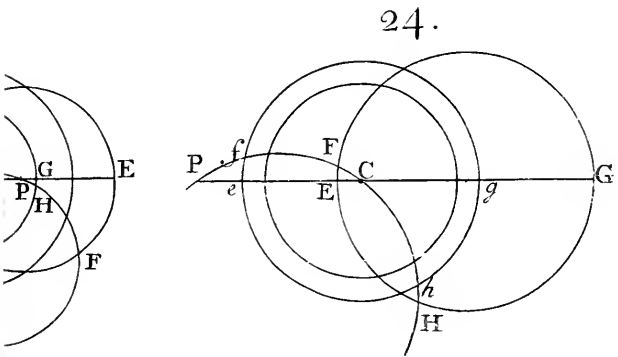
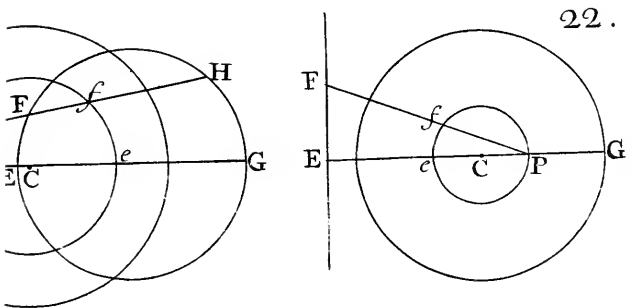
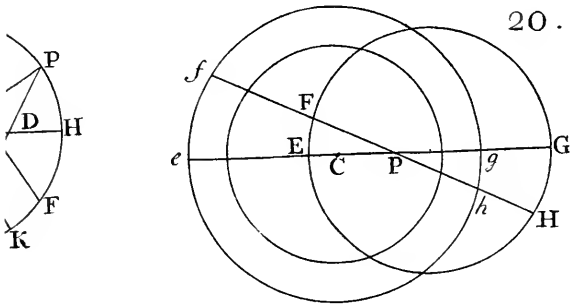

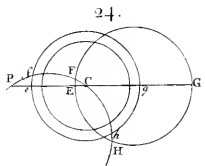
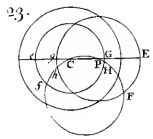
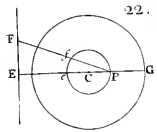
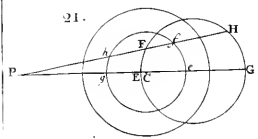
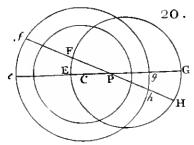
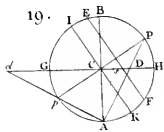

Cor. 3. If P be the projected center of any circle Fig. EFG, any right lines EG, FH passing thro' P will 20. intercept equal arches EF, GH.

For in any circle of the sphere, any two lines, passing thro' the center, intercept equal arches; and these are projected into right lines, passing thro' the projected center P , and therefore EF, GH, represent equal arches.

P R O P. IX.

If EFGH, *esgb* represent two equal circles, where- 20. of EFG is as far distant from its pole P , as *esg* is 21. from the projecting point. I say, any two right lines (*eEP*, and *fFP*,) being drawn thro' P , will intercept equal arches (in representation) of these circles; on the same side, if P falls within the circles; but on the contrary side, if without; that is, $EF = ef$, and $GH = gb$.

For by the nature of the section of a sphere; any two circles passing thro' two given points or poles on the surface of the sphere, will intercept equal arches of two other circles equidistant from these poles. Therefore the circles EFG and *esg* on the sphere, are equally cut by the planes of any two circles passing thro' the projecting point and the pole P , on the sphere. But these circles (by Prop. I.) are projected into the right lines *Pe* and *Pf*, passing thro' P . And the intercepted arches representing equal arches on the sphere, are therefore equal, that is, $EF = ef$, and $GH = gb$.

Cor. 1. If a circle is projected into a right line EF, 22. perpendicular to the line of measures EG; and if from the center C a circle *esP* be described passing thro' its pole P , and *Pf* be drawn; then arch *ef* = EF. And if any other circle be described whose vertex is P , the arch *ef* will always be equal to EF.

Fig. Cor. 2. Hence also, if from the pole of a great circle there be drawn two right lines, the intercepted arch of the projected great circle will be equal to the intercepted arch of the primitive.

23. Cor. 3. After the same manner, if there be two
 24. equal circles EF , ef , whereof one is as far from the pole P , as the other is from the pole of projection e , opposite to the projecting point. Then any circle drawn thro' the points P , C , will intercept equal arch $EF = ef$; and $GH = gb$, between it and the line of measures PCG .

For this is true on the sphere, and their projections are the same.

Cor. 4. If from an angular point be drawn two right lines thro' the poles of its sides; the intercepted arch of the primitive, will be equal to that angle.

For the distance of the poles is equal to that angle.

P R O P. X.

25. If QH , NK be two equal circles, whereof NK
 26. is as far from the projecting point as QH from its pole P ; and if they be projected into the circles whose radii are MC or CL , and DF or FG , F being the center of DG , and E the projected pole. I say, the pole E will be distant from their centers in proportion to the radii of the circles; that is, $CE : EF :: CL : DF$ or FG .

For since NK and ML are parallel, and arch $NI = PH$, therefore $\angle ELI = NKI$ (or nKI) = GIP ; therefore the triangles IEL and IEG are similar, whence $EL : EI :: EI : EG$. Again the angle $EMI = KNI = PIQ$, and therefore the triangles IEM and IED are similar, whence $EM : EI :: EI : ED$. Therefore $EF^2 = EL \times EG =$
EM

EM × ED. Consequently EM : EL :: EG : ED ; Fig.
 and by composition $\frac{EM + EL}{2} : \frac{EM - EL}{2} ::$
 $\frac{EG + ED}{2} : \frac{EG - ED}{2}$; that is, CM : EC :: FG :
 FF. Q. E. D.

Cor. 1. Hence if the circle KN be as far from 25.
 the projecting point, as QH is from either of its poles, 26.
 and if E, O, be its projected poles ; then will EL :
 EM :: ED :: EG :: OD : OG.

This follows from the foregoing demonstration,
 and Cor. 4. Prop. VII.

Cor. 2. Hence also if F be the center, and FD the 25.
 radius of any circle QH, and E, O the projected 26.
 poles ; then EF : DF :: DF : FO.

For it follows from Cor. 1, that $\frac{EG + ED}{2} :$
 $\frac{EG - ED}{2} :: OG + OD : \frac{OG - OD}{2}$.

Cor. 3. Hence if the circle DBG, be as far from 27.
 its projected pole P, as LMN is from the projecting 28.
 point ; and if any right lines be drawn thro' P, as
 MPG, NPK, they will cut off similar arches GK,
 MN in the two circles.

For from the centers C, F, draw the lines CN,
 FK, then since the angles CPN, and FPK are
 equal, and by this Prop. CP : CN :: FP : FK ;
 therefore (Geom. II. 16.) ; the triangles PCN and
 PFK are similar ; and the angle PCN = ∠ PFK ;
 therefore the arches MN and GK are similar.

Cor. 4. Hence also if thro' the projected pole P of 27.
 any circle DBG, a right line BPK be drawn. Then 28.
 I say the degrees in the arch GK shall be the measure
 of DB in the projection. And the degrees in DB,
 shall be the measure of GK in the projection.

For

Fig. For (by Prop. IX.) the arch MN is the measure of DB, and therefore GK which is similar to MN, will also be the measure of it.

Cor. 5. *The centers of all projected circles are all beyond the projected poles (in respect to the center of the primitives); and none of their centers can fall between them.*

20. Cor. 6. *Hence it follows (by Cor. 5. and Pr. VIII. Cor. 3.) that all circles that are not parallel to the primitive have equal arches on the sphere represented by unequal arches on the plane of projection.*

For if P be the projected center, then GH is greater than EF.

SCHOLIUM.

It will be easy by the foregoing propositions to describe the representation of any circle, and the reverse will easily show what circle of the sphere any projected circle represents. What follows hereafter is deduced from the foregoing propositions, and will easily be understood without any other demonstration.

If the sphere was to be projected on any plane parallel to the primitive, 'tis all the same thing. For the cones of rays issuing from the projecting point, are all cut by parallel planes into similar sections, it only makes the projections bigger or less, according to the distance of the plane of projection, whilst they are still similar; and amounts to no more than projecting from different scales upon the same plane. And therefore the projecting the sphere on the plane of a lesser circle is only projecting it upon the great circle parallel thereto, and continuing all the lines of the scheme to that lesser circle.

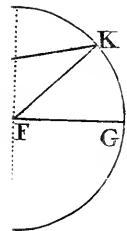
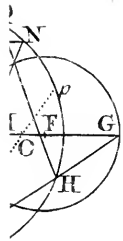

30.



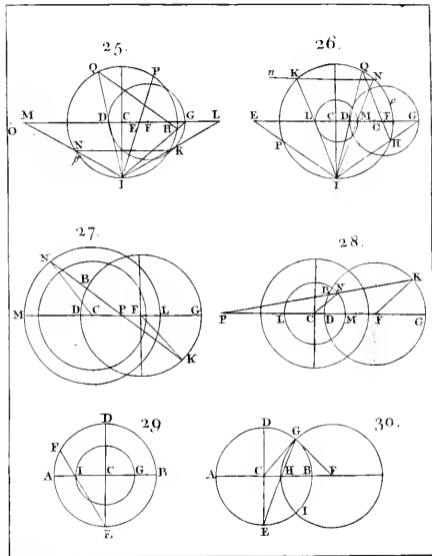

P R O P. XI. *Prob.*

To draw a circle parallel to the primitive at a given distance from its pole.

Rule.

Thro' the center C draw two diameters AB, DE, 29. perpendicular to one another. Take in your compasses the distance of the circle from the pole of the primitive opposite to the projecting point, and set it from D to F; from E draw EF to intersect AB in I; with the radius CI, and center C, describe the circle GI required.

By the plain Scale.

With the radius CI, equal to the semi-tangent of the circles distance from the pole of projection opposite the projecting point, describe the circle IG. Here the radius of projection CA, is the tangent of 45° , or the semi-tangent of 90° .

P R O P. XII. *Prob.*

To draw a lesser circle perpendicular to the primitive at a given distance from the pole of that circle.

Rule.

Thro' the pole B draw the line of measures AB, 30. make BG the circle's distance from its pole, and draw CG, and GF perpendicular to it; with the radius FG describe the circle GI required.

By the Scale.

Set the secant of the circle's distance from its pole from C to F, gives the center. With the tangent of that distance for a radius, describe the circle GI.

Or thus, make BG the circle's distance from its pole; and GF its tangent, set from G, gives F the center;

Fig. center ; thro' G describe the circle GI from the center F.

Cor. Hence a great circle perpendicular to the primitive, is a right line CDE drawn thro' the center perpendicular to the line of measures.

SCHOLIUM.

When the center F lyes at too a great a distance ; draw EG, to cut AB in H ; or lay the semi-tangent of DG from C to H. And thro' the three points G, H, I, draw a circle with a bow.

P R O P. XIII. Prob.

To describe an oblique circle at a given distance from a pole given.

Rule.

31. Draw the line of measures AB thro' the given point p , if that point is given ; and draw DE \perp to it, also draw $E p P$. Or if the point p is not given, set the height of the pole above the primitive from B to P. Then from P set off $PH = PI =$ circle's distance from its pole ; and draw EH, EI, to intersect AB in F and G. About the diameter FG describe the circle required.

By the Scale.

If the point P is given, apply Cp to the semi-tangents and it gives the distance of the pole from D, the pole of projection opposite to the projecting point. This distance being had, you'll easily find the greatest and nearest distances of the circle from the pole of the primitive opposite to the projecting point ; take the semi tangents of these distances and set from C to G and F, both the same way if the circle lye all on one side, but each its own way, if on different sides of D. And then FG is the diameter of the circle required to be drawn.

Cor.

Cor. 1. If F be the pole of a great circle as of Fig. DLE. Draw EFH , and make $HP = DH$, and 31 . draw EpP , and then P is its center.

Or thus, draw EFH thro' the pole F , make HK 90 degrees; draw EK cutting the line of measures in L . Thro' the three points D, L, E , draw the great circle required.

Cor. 2. Hence it will be easy to draw one circle parallel to another.

P R O P. XIV. Prob.

Thro' two given points A, B , to draw a great circle.

Rule.

Thro' one of the points A , draw a line thro' the 32. center, ACG ; and EF perpendicular to it. Then draw AE , and EG perpendicular to it. Thro' the three points A, B, G draw the circle required.

Or thus; From E (found as before) draw EH , and then HCI , and lastly EIG , gives G a third point, thro' which the circle must pass.

By the Scale.

Draw ACG ; and apply AC to the semi-tangents, find the degrees, set the semi-tangent of its supplement from C to G , for a third point.

Or thus; Apply AC to the tangents, and set the tangent of its complement from C to G . And thro' the three points ABG , describe the circle required.

For since HEI or AEG is a right angle, therefore A, G are opposite points of the sphere; and therefore all circles passing thro' A and G are great circles.

SCHOLIUM.

If the points A, B, G lie nearly in a right line, then you may draw a circle thro' them with a bow.

P R O P.

Fig.

P R O P. XV. *Prob.*

About a pole given, to describe a circle thro' a given point.

Rule.

23. Let P be the pole, and B the given point; thro' P, B describe the great circle AD (by Prop. XIV.), whose center is E; thro' the center C draw CPH; and from the center E, draw EB, and BF perpendicular to it. To the center F, and radius FB describe the circle BGH required.

P R O P. XVI. *Prob.*

To find the poles of any circle FNG.

Rule.

31. Thro' its center draw the line of measures AG, and DE perpendicular to it. Draw EFH, and set its distance (from its own pole) from H to P, and draw EpP, then *p* is the pole.

Or thus, Draw EFH, EIG, and bisect HI in P, and draw EpP, and *p* is the internal pole. Lastly draw PCQ, and EQq, and *q* is the external pole.

In a great circle DLE, draw ELK, and make $DH = AK$, (or $KH = AD$, and draw EFH, and F is the pole.

By the Scale.

Apply CF to the semi-tangents, and note the degrees. Take the sum of these degrees and of the circle's distance from its pole, if the circle lie all on one side, but their difference if it encompasses the pole of projection; set the semi-tangent of this sum or difference from C to the internal pole *p*. And the semi-tangent of its supplement Cq, gives the external pole *q*.

Or thus, Apply CF and CG to the semi-tangents, set the semi-tangent of half the sum of the degrees (if

(if

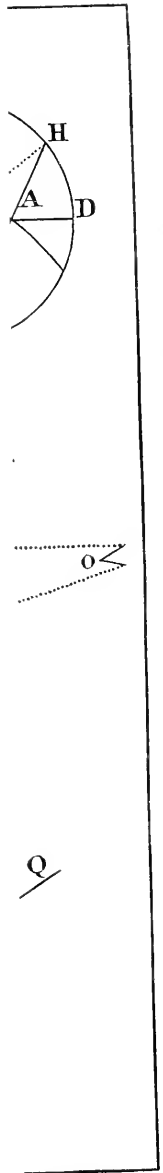

V. p. 26.

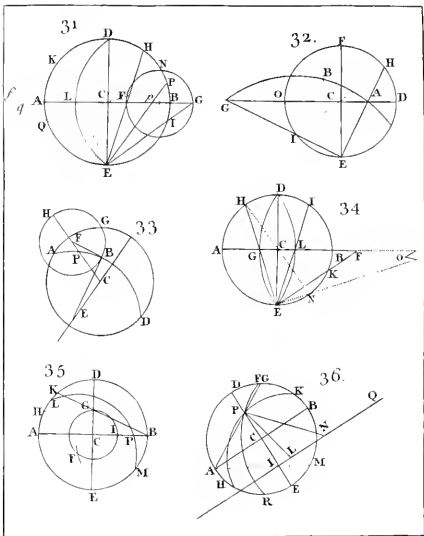

(if the circle lies all one way) or of half the difference (if it encompasses the pole of projection), from C to the pole p ; and the semi-tangent of the supplement, Cq gives the external pole q . Fig. 31.

In a great circle as DLE, draw the line of measures AB perp. to DE; and set the tangent and co-tangent of half its inclination, from the center C, different ways to F and f ; which gives the internal and external poles F and f .

P R O P. XVII. *Prob.*

To draw a great circle at any given inclination above the primitive; or making any given angle with it, at a given point.

Rule.

Draw the line of measures AB; and DCE perpendicular to it. Make $EK = 2HD =$ twice the complement of the circle's inclination; (or $DK = 2AH =$ twice the inclination); and draw EKF, then F is the center of EGD, the circle required. 34.

Or thus; Draw DE and AB perp. to it, and let D be the point given. Make AH the inclination, and draw EGH and HCN; and ENO, to cut AB in O. Then bisect GO in F, for the center of the circle required.

By the Scale.

Set the tangent of the inclination in the line of measures from C to F, then F is the center. Set the semi-tangent of the complement from C to G; then GF or DF is the radius.

Or the secant of the inclination set from G or D to F gives the center.

Cor. To draw an oblique circle to make a given angle with a given oblique circle DGE at D. Draw EGH, and set the given angle from H to I, and draw ELL. thro' D, L, E describe a great circle.

Fig.

P R O P. XVIII. *Prob.*

Through a given point P, to draw a great circle, to make a given angle with the primitive.

Rule.

35. Thro' the point given P and the center C draw the line AB; and DE perpendicular to it. Set the given angle from A to H and from H to K, and draw BGK; with radius CG, and center C describe the circle GIF; and with radius BG and center P cross that circle in F. Then with radius FP and center F, describe the circle LPM required.

By the Scale.

With the tangent of the given angle and one foot in C, describe the arch FG. With the secant of the given angle and one foot in the given point P, cross that arch at F. From the center F describe a circle thro' the point P.

P R O P. XIX. *Prob.*

To draw a great circle to make a given angle with a given oblique circle FPR, at a given point P, in that circle.

Rule.

36. Thro' the center C and the given point P, draw the right line DE; and AB perpendicular to it; draw APG and make $BM = 2DG$; and draw AM to cut DE in I. Draw IQ perpendicular to DE, then IQ is the line wherein the centers of all circles are found which pass thro' the point P. Find N the center of the given circle FPR, and make the angle NPL equal to the given angle, then L is the center of the circle HPK required.

By

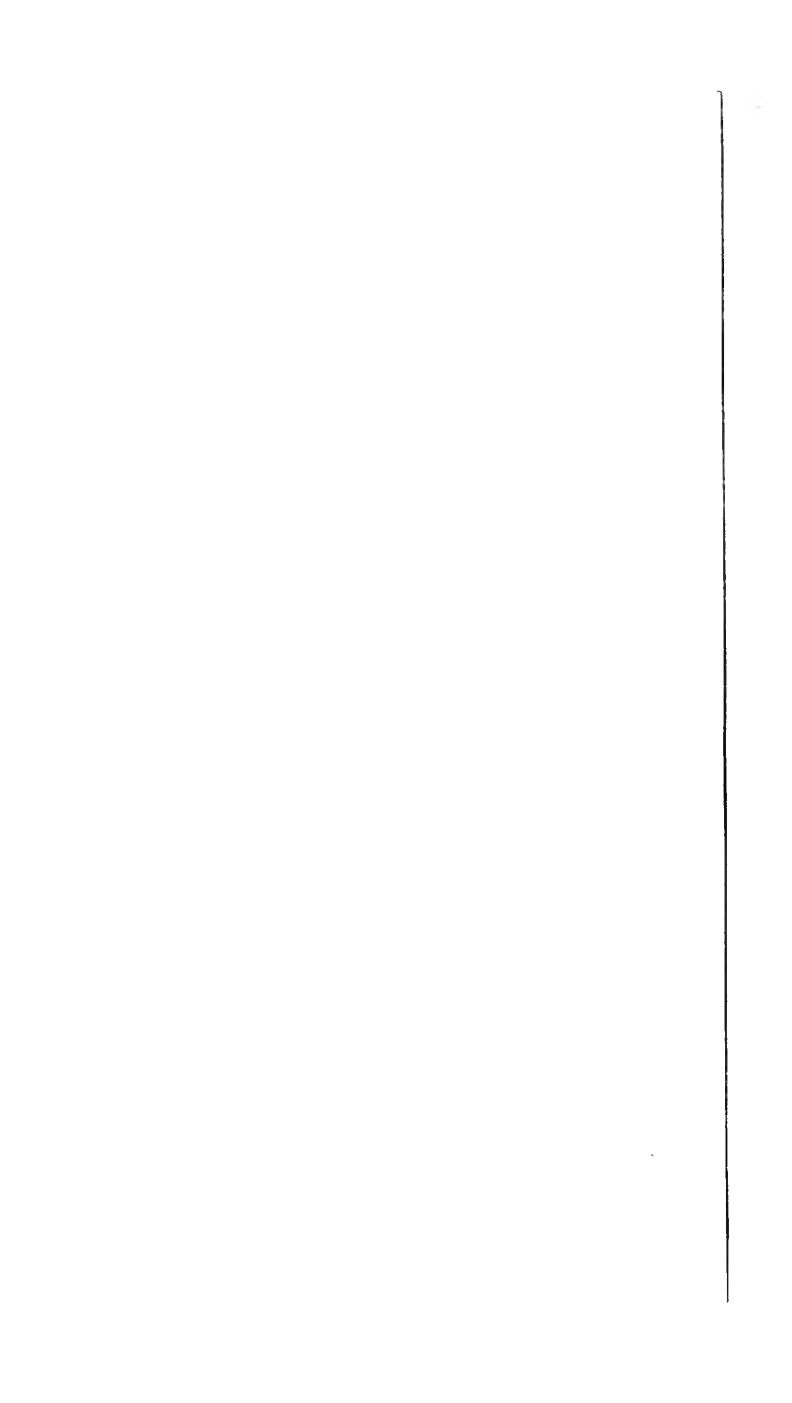

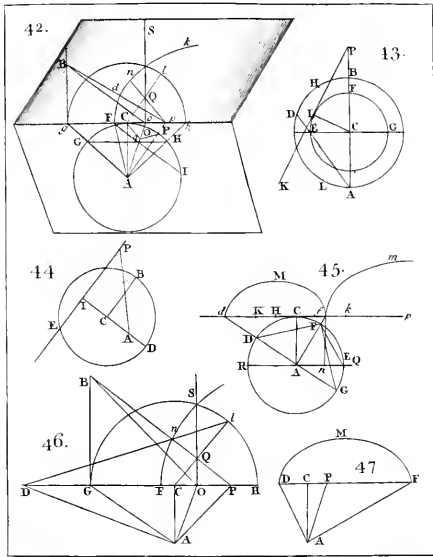

Projection.

VII pa. 44.



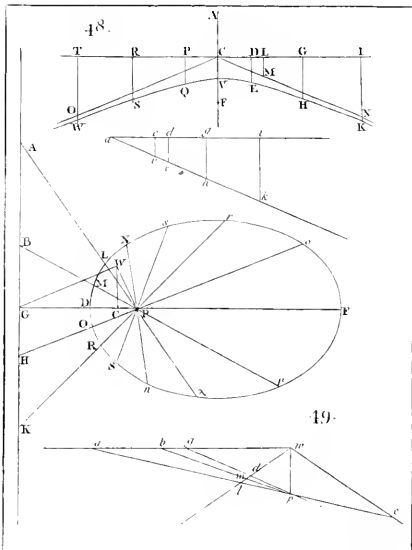

Proprietor

By the Scale.

Fig.

Thro' P and C draw DE; apply CP to the semi-tangents, and set the tangent of its complement from C to I (or the secant from P to I) On DI erect the perpendicular IQ. Find the center N of FPR, and make the angle NPL = angle given, and L is the center.

36.

Cor. If one circle is to be drawn perpendicular to another, it must be drawn thro' its poles.

P R O P. XX. *Prob.*

To draw a great circle thro' a given point P, to make a given angle with a given great circle DE.

Rule.

About the given point P as a pole (by Prop. 13. 37: Cor. 1.) describe the great circle FG; find I the pole of the given circle DE, and (by Prop. 16.) about the pole I (by Prop. 13.) describe the small circle HKL at a distance equal to the given angle, to intersect FG in H; about the pole H describe (by Prop. 13.) the great circle APB required.

P R O P. XXI. *Prob.*

To draw a great circle to cut two given great circles abd, ebf at given angles.

Rule.

Find the poles *s*, *r*, of the two given circles, 50: by Prop. 16. about which draw two parallels *pbk*, *pnk*, at the distances respectively equal to the angles given by Prop. 13. the point of intersection P, is the pole of the circle *moq* required.

Cor. Hence, to draw a right circle to make with an oblique circle, abd, any given angle. Draw a parallel pbk at a distance from the pole of the oblique circle, equal to the given angle. Its intersection

C

f with

Fig. *f* with the primitive, gives the pole of the right circle
 get required.

P R O P. XXII. *Prob.*

To lay any number of degrees on a great circle, or
 to measure any arch of it.

Rule.

38. Let AFI be the primitive; find the internal pole
 P of the given circle DEH (by Prop 16.) lay the
 degrees on the primitive from A to F, and draw
 PA, PF, intercepting the part required DE. Or
 to measure DE, draw PEF and PDA, and AF is
 its measure, and applied to the line of chords shows
 how many degrees it is.

Or thus; Find the external pole *p* of the given
 circle, set the given degrees from l to K, and draw
*p*I, *p*K, intercepting the part DE required. Or to
 measure DE, thro' D and E draw *p*I, *p*K, then KI
 is the measure of DE.

Or thus; Thro' the internal pole P, draw the
 lines DPG, and EPL; setting the given degrees
 from G to L in the circle GL; then DE is the arch
 required. Or if DE be to be measured, then the
 degrees in the arch GL is the measure of DE.

Or thus; Set the given degrees from G to H in
 the circle GL and from the external pole P, draw
*p*G, *p*H, intercepting DE the arch required Or
 to measure DE, draw *p*DG, *p*EH, then the degrees
 in GH, is equal to DE.

By the Scale for right Circles.

38. Let CA be the right circle, take the number of
 degrees off the semi-tangents and set from C to D
 for the arch CD. Or if the given degrees are to
 be set from A, then take the degrees off the semi-
 tangents from 90° towards the beginning, and set
 from A to D. And if CD was to be measured,
 apply

apply it to the beginning of the semi-tangents; and Fig. to measure AD, apply it from 90° backwards, and the degrees intercepted gives its measure.

SCHOLIUM.

The primitive is measured by the line of chords, or else it is actually divided into degrees.

P R O P. XXIII. *Prob.*

To set any number of degrees on a lesser circle, or to measure any arch of it.

Rule.

Let the lesser circle be DEH; find its internal pole P , by Prop. 16. describe the circle AFK parallel to the primitive, by Prop. 11. and as far from the projecting point, as the given circle DE is from its internal pole P , set the given degrees from A to F, and draw PA, PF intersecting the given circle in D, E; then DE is the arch required. Or to measure DE, draw PDA, PEF, and AF shows the degrees in DE. 38.

Or thus; Find the external pole p , of the given circle by Prop. 16. describe the lesser circle AFK as far from the projecting point, as DE the given circle is from its pole p , by Prop. 11. set the degrees from I to K and draw pDI , pEK , then DE represents the given number of degrees. Or to measure DE; draw pDI , pEK ; and KI is the measure of DE.

Or thus; Let O be the center of the given circle DEH; thro' the internal pole P , draw lines DPG, EPL, divide the quadrant GQ into 90 equal degrees, and if the given degrees be set from G to L, then DE will represent these degrees. Or the degrees in GL will measure DE.

Or thus; Divide the quadrant GR into 90 equal parts or degrees, and set the given degrees from G to H, and draw pDG , pEH , from the external pole p ; then DE will represent the given degrees. Or

Fig. thro' D, E drawing pDG , pEH , then the number of equal degrees in GH is the measure of DE .

S C H O L I U M.

Any circle parallel to the primitive is divided or measured, by drawing lines from the center, to the like divisions of the primitive. Or by help of the chords on the sector, set to the radius of that circle.

P R O P. XXIV. *Prob.*

To measure any angle.

Rule.

By Cor. 1. Prop. 13. About the angular point as a pole, describe a great circle, and note where it intersects the legs of the angle; thro' these points of intersection, and the angular point, draw two right lines, to cut the primitive; the arch of the primitive intercepted between them is the measure of the angle. This needs no example.

Or thus; by Prop. 16. Find the two poles of the containing sides, (the nearest, if it be an acute angle, otherwise the furthest) and thro' the angular point and these poles, draw right lines to the primitive, then the intercepted arch of the primitive is the angle required. As if the angle AEL was required. Let C and F be the poles of EA and EL . From the angular point E , draw ECD and EFH . Then the arch of the primitive DH , is the measure of the angle AEL .

S C H O L I U M.

Because in the Stereographic Projection of the Sphere, all circles are projected either into circles or right lines, which are easily described; therefore this sort of projection is preferred before all others. Also those planes are preferred before others to project upon, where most circles are projected into right lines, they being easier to describe and measure than circles are; such are the projections on the planes of the meridian and solstitial colure.

S E C T. III.

Fig.

The Gnomonical Projection of the SPHERE.

P R O P. I.

Every great circle as BAD is projected into a right 39.
line, perpendicular to the line of measures, and distant from the center, the co-tangent of its inclination, or the tangent of its nearest distance from the pole of projection.

Let CBED be perpendicular both to the given circle BAD and plane of projection, and then the intersection CF will be the line of measures. Now since the plane of the circle BD, and the plane of projection are both perpendicular to BCDE, therefore their common section will also be perpendicular to BCDE, and consequently to the line of measures CF. Now since the projecting point A is in the plane of the circle, all the points of it will be projected into that section; that is, into a right line passing thro' *d*, and perpendicular to *Cd*. And *Cd* is the tangent of CD, or co-tangent of *CdA*. Q. E. D.

Cor. 1. A great circle perpendicular to the plane of 39.
projection is projected into a right line passing thro' the centre of projection; and any arch is projected into its correspondent tangent.

Thus the arch CD is projected into the tangent *Cd*.

Cor. 2. Any point as D, or the pole of any circle, is projected into a point *d* distant from the pole of projection C, the tangent of that distance.

Cor. 3. If two great circles be perpendicular to each other, and one of them passes thro' the pole of projection;

Fig. tion; they will be projected into two right lines perpendicular to each other.

39. For the representation of that circle which passes thro' the pole of projection is the line of measures of the other circle.

Cor. 4. And hence if a great circle be perpendicular to several other great circles, and its representation pass thro' the center of projection; then all these circles will be represented by lines parallel to one another, and perpendicular to the line of measures or representation of that first circle.

P R O P. II.

39. If two great circles intersect in the pole of projection; their representations shall make an angle at the center of the plane of projection equal to the angle made by these circles on the sphere.

For since both these circles are perpendicular to the plane of projection; the angle made by their intersections with this plane, is the same as the angle made by these circles. Q. E. D.

P R O P. III.

Any lesser circle parallel to the plane of projection is projected into a circle, whose center is the pole of projection; and radius the tangent of the circle's distance from the pole of projection.

39. Let the circle PI be parallel to the plane GF, then the equal arches PC, CI are projected into the equal tangents GC, CH; and therefore C the point of contact and pole of the circle PI and of the projection, is the center of the representation GH. Q. E. D.

Cor. If a circle be parallel to the plane of projection, and 45 degrees from the pole, it is projected into a circle

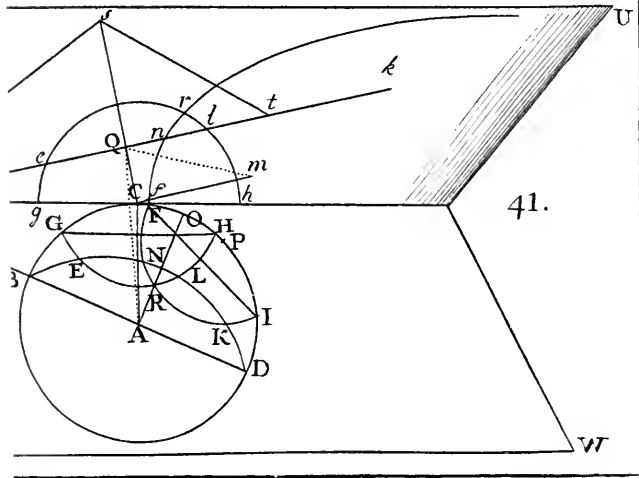
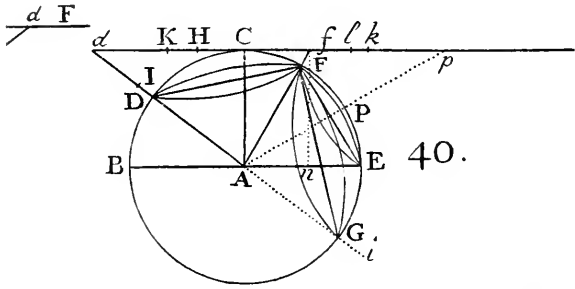
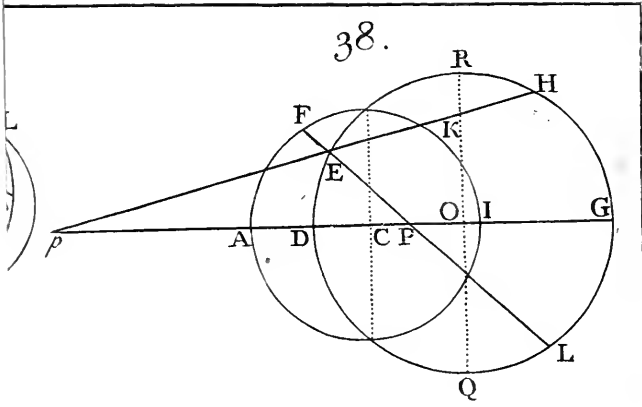

ON THE PROJECTION OF CIRCLES

be projected into two right lines perpendicular to each other. The representation of that circle which passes through the center of projection is the line of measures.

Hence if a great circle be perpendicular to the plane of projection, and its representation be a right line; then all the circles which are represented by lines parallel to one another, and perpendicular to the line of measures or representation of the great circle.

PRO P. II.

Two circles intersect in the pole of projection; the angle which they make at the center of projection is equal to the angle which they make on the sphere.

When these circles are perpendicular to the plane of projection; the angle made by their representations in this plane, is the same as the angle which they make on the sphere. Q. E. D.

PRO P. III.

A line drawn parallel to the plane of projection is projected into a straight line, whose center is the pole of projection, and whose distance from the center of projection is the same as the distance of the circle's center from the pole of projection.

Let PI be parallel to the plane GF , and let PC , CI be projected into the lines GC , CH ; and therefore C the center of the circle PI and of its representation.

Let PI be parallel to the plane of projection, and let PC be perpendicular to the plane of projection; then C is the center of the circle PI and of its representation.

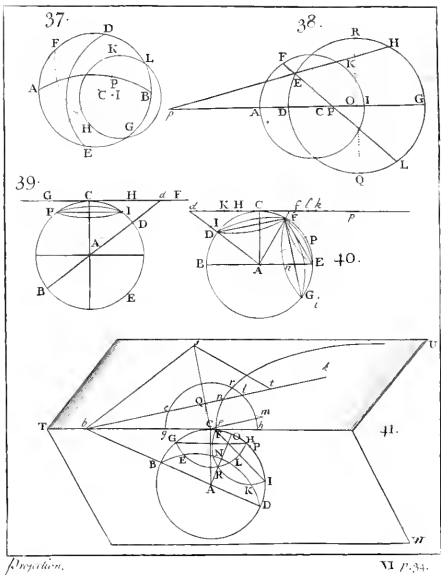

a circle equal to a great circle of the sphere; and may therefore be looked upon as the primitive circle in this projection, and its radius the radius of projection. Fig.

P R O P. IV.

Every lesser circle (not parallel to the plane of projection) is projected into a conic section, whose transverse axis is in the line of measures, and whose nearest vertex is distant from the center of the plane the tangent of its nearest distance from the pole of projection; and the other vertex is distant the tangent of its furthest distance. 40.

Let BE be parallel to the line of measures dp , then any circle is the base of a cone whose vertex is at A, and therefore that cone being produced will be cut by the plane of projection in some conic section; thus the circle whose diameter is DF will be cut by the plane in an ellipsis whose transverse is df ; and Cd is the tangent of CAD, and Cf of CF. In like manner the cone AFE being cut by the plane, f will be the nearest vertex; and the other point into which E is projected is at an infinite distance. Also the cone AFG (whose base is the circle FG) being cut by the plane f is the nearest vertex; and GA being produced gives d the other vertex. Q. E. D.

Cor. 1. If the distance of the furthest point of the circle be less than 90° from the pole of projection, then it will be projected into an ellipsis.

Thus DF is projected into df , and DC being less than 90° , the section df is an ellipsis, whose vertices are at d and f ; for the plane df cuts both sides of the cone, dA , fA .

Cor. 2. If the furthest point be more than 90 degrees from the pole of projection, it will be projected

Fig. into an hyperbola. Thus the circle FG is projected into
40. an hyperbola whose vertices are f and d , and transverse fd .

For the plane dp cuts only the side Af of the cone.

Cor. 3. And in the circle EF , where the furthest point E is 90° from C ; it will be projected into a parabola, whose vertex is f .

For the plane dp (cutting the cone $F AE$) is parallel to the side AE .

Cor. 4. If H be the center, and K, k, l , the focus of the ellipsis, hyperbola, or parabola; then $HK = \frac{Ad - Af}{2}$ for the ellipsis, and $Hk = \frac{Ad + Af}{2}$ for the hyperbola; and (drawing fn perpendicular on AE) $fl = \frac{nE + Ff}{2}$, for the parabola; which are the representations of the circles DF, FG, FE respectively.

This all appears from the Conic Sections.

P R O P. V.

41. Let the plane TW be perpendicular to the plane of projection TV , and BCD a great circle of the sphere in the plane TW . And let the great circle BED be projected in the right line bek . Draw $CQS \perp bk$, and $Cm \parallel$ to it and equal to CA , and make $QS = Qm$; then I say any angle $Qst = Qt$.

Suppose the hypotenuse AQ to be drawn, then since the plane ACQ is perpendicular to the plane Tv , and bQ is \perp to the intersection CQ , therefore bQ is perpendicular to the plane ACQ , and consequently bQ is perpendicular to the hypotenuse AQ . But $AQ = Qm = Qs$, and Qs is also perpendicular to bQ . Therefore all angles made at S cut the line bQ in the same points as the angles made
at

at A ; but by the angles at A the circle BED is Fig. projected into the line bQ . Therefore the angles 41 . at s are the measures of the parts of the projected circle bQ ; and s is the dividing center thereof. *Q. E. D.*

Cor. 1. *Any great circle tQb is projected into a line of tangents to the radius SQ .*

For Qt is the tangent of the angle QSt to the radius QS or Qm .

Cor. 2. *If the circle bC pass thro' the center of projection ; then A the projecting point is the dividing center thereof. And Cb is the tangent of its correspondent arch CB , to CA the radius of projection.*

P R O P. VI.

Let the parallel circle GEH be as far from the 41 . pole of projection C as the circle FKI is from its pole P ; and let the distance of the poles C, P be bisected by the radius AO , and draw bAD perpendicular to AO ; then any right line bek drawn thro' b , will cut off the arches $bl = Fn$, and $ge = kf$ (supposing f the other vertex), in the representations of these equal circles in the plane of projection.

For let $G, E, R, L, H, N, R, K, I$ be respectively projected into the points $g, e, r, l, h, n, r, k, f$. Then since in the sphere, the arch $BF = DH$, and arch $BG = DI$. And the great circle $BEKD$ makes the angles at B and D equal, and is projected into a right line as bl ; therefore the triangular figures BFN and DHL are similar, and equal ; and likewise BGE , and DIK are similar and equal, and $LH = NF$, and $KI = EG$; whence it is evident their projections $lb = nF$, and $kf = ge$. *Q. E. D.*

P R O P.

P R O P. VII.

42. *If blg and Fnk be the projections of two equal circles, whereof one is as far from its pole P as the other from its pole C ; which is the center of projection; and if the distance of the projected poles C, p be divided in o , so that the degrees in Co, op , be equal, and the perpendicular oS be erected to the line of measures gb . I say the lines pn, Cl , drawn from the poles C, p thro' any point Q in the line oS , will cut off the arch $Fn = \angle QCP$.*

For drawing the great circle GPI , in a plane perpendicular to the plane of projection. The great circle AO perpendicular to CP is projected into oS by Prop. I. Cor. 3. Now let Q be the projection of q , and since pQ, CQ are right lines, therefore they represent the great circles Pq, Cq . But the spherical triangle PqC is an isocetes-triangle, and therefore the angles at P and C are equal. But because P is the pole of FI , therefore the great circle Pq continued, will cut an arch off $FI = \angle CPq = \angle PCq = \angle QCP$ by Prop. II. That is (since Fn represents the part cut off from FI) arch $Fn = \text{arch } lb$ or $\angle QCh$. *Q. E. D.*

Cor. Hence if from the projected pole p of any circle, a perpendicular be erected to the line of measures; it will cut off a quadrant from the representation of that circle.

For that perpendicular will be parallel to OS ; Q being at an infinite distance.

P R O P. VIII.

Let Fnk be the projection of any circle FI , and p 42.
 the projected pole P . And if Cg be the co-tangent of
 CAP , and gB perpendicular to the line of measures
 gC , and CAP be bisected by AO , and the line oB , be
 drawn to any point B , and also pB cutting Fnk in d .
 I say the angle $goB = \text{arch } Fd$.

For the arch PG is a quadrant, and the $\angle goA$
 $= \angle gpa + \angle oAp =$ (because GCA and gAp are
 right angles) $gAC + oAp = gAC + CAo = \angle$
 gAo . Therefore $gA = go$, consequently o is the
 dividing center of gB the representation of GA ; and
 consequently by Prop. V. $\angle goB$ is the measure of
 gB . But since pq represents a quadrant, therefore
 p is the pole of gB , and therefore the great circle
 pdB passing thro' the pole of the circles gB and Fz
 will cut off equal arches in both, that is $Fd = gB$
 $= \angle goB$. Q. E. D.

Cor. The $\angle goB$ is the measure of the angle gpB .

For the triangle gpB represents a triangle on the
 sphere wherein the arch which gB represents is equal
 to the angle which $\angle p$ represents, because gp is
 90 degrees. Therefore goB is the measure of both.

S C H O L I U M.

Thus far I have treated of the theory; what
 follows is the practical part, and depends altogeth-
 er on what is above delivered, in which I think
 no difficulty can occur. In the Gnomonical Projec-
 tion, the plane projected on, is supposed to touch
 the hemisphere to be projected, in its vertex; and
 the point of contact will be *the center of projection*.
 But if it be required to project upon any plane pa-
 rallel

Fig. rallel to this touching plane, the process will be no way different, and is only taking a greater or lesser radius of projection, according to the greater or lesser distance; which is in effect projecting a greater or lesser sphere upon its touching plane.

When you have the sphere to project this way, upon a given plane; it will assist the imagination, if you suppose yourself placed in the center of the sphere with your face towards the plane, whose position is given; and from thence projecting with your eye, the circles of the sphere upon this plane.

P R O P. IX. *Prob.*

43. *To draw a great circle, thro' a given point, and at a given distance from the pole of projection.*

Rule.

Describe the circle ADB with the radius of projection, and thro' the given point P draw the right line PCA, and CE perpendicular to it; make the angle CAE = given distance of the circle from C, and thro' E describe the circle EFG, and thro' P draw the line PK touching the circle in I, then is PIK the circle required.

By the plain Scale.

With the tangent of the circle's distance from the pole of projection C, describe the circle EIF, and draw PK to touch this circle; and PIK is the circle required.

P R O P. X. *Prob.*

43. *To draw a great circle perpendicular to a given great circle, which passes thro' the pole of projection; and at a given distance from that pole.*

Rule.

Draw the primitive ADB. Let CI be the given circle, draw CL perpendicular to CI, and make the angle

angle $CLI =$ the given distance; thro' I draw KP Fig. parallel to CL for the circle required. 43.

By the Scale.

In the given circle CI , set the tangent of the given distance, from C to I ; thro' I draw KP perpendicular to CI , then KP is the circle required.

P R O P. XI. *Prob.*

To measure any part of a great circle; or to set any number of degrees thereon. 44.

Rule.

Let EP be the great circle; thro' C draw ID perpendicular to EP , and CB parallel to it. Let EBD be a circle described with the radius of projection CB , make $IA = IB$; then A is the dividing center of EP , consequently drawing AP ; the $\sphericalangle IAP =$ measure of the given arch IP .

Or if the degrees be given, make the $\sphericalangle IAP =$ these given degrees, which cuts off IP , the arch correspondent thereto.

By the Scale.

Draw ICD perpendicular to EP ; apply CI to the tangents, and set the semi-tangent of its complement from C to A , gives the dividing center of EP , &c.

P R O P. XII. *Prob.*

To draw a great circle to make a given angle with a given great circle, at a given point; or to measure an angle made by two great circles. 51.

Rule.

Let P be the given point, and PB the given great circle. Draw thro' P , and C the center of projection, the line PCG , to which from C draw CA perpendicular,

Fig. 51. dicular, and equal to the radius of projection. Draw PA and AG perpendicular to it, at G erect BD perpendicular to GC, cutting PB in B; draw AO bisecting the angle CAP; then at the point O, make $BOD = \text{angle given}$, and from D draw the line DP, then BPD is the angle required.

Or if the degrees in the angle BPD be required, from the points B, D, draw the lines BO, DO; and the angle BOD is the measure of BPD.

Cor. If an angle be required to be made at the pole or center of projection, equal to a given angle; this is no more than drawing two lines from the center making the angle required. And if one great circle be to be drawn \perp to another great circle, it must be drawn thro' its pole.

P R O P. XIII. *Prob.*

43. *To project a lesser circle parallel to the primitive.*

Rule.

With the radius of projection AC, and center C, describe the primitive circle ADB, by Cor. Prop. III. and draw ACB, and GCE perpendicular to it.

Set the circle's distance from its pole from B to H, and from H to D, and draw AFD. With radius CE describe the circle EFG required.

By the Scale.

With the radius CE equal to the tangent of the circle's distance from its pole, describe the circle EFG, for the circle required.

P R O P. XIV. *Prob.*

48. *To draw a lesser circle perpendicular to the plane of projection.*

Rule.

Thro' the center of projection C, draw its parallel great circle TI. At C make the angle ICN and

and TCO = the given circle's distance from its pa-
 Fig. rallel great circle TI; make CL equal radius of 48.
 projection, and draw LM perpendicular to CL.
 Set LM from C to V, or CM from C to F. Then
 thro' the vertex V between the asymptotes CN,
 CO describe the hyperbola WVK. Or to the fo-
 cus F, and semi-transverse CV, describe the hyper-
 bola; for the circle required.

Otherwise by Points.

Thro' the center of projection C draw the line of
 measures CF, and TCI perpendicular to it, draw
 any number of right lines CV, DE, GH, IK &c.
 and PQ, RS, TW, &c. perpendicular to TI. And
 by Prop. XI. make CV, DE, GH, &c. each e-
 qual to the distance of the given circle from its pa-
 rallel great circle; then all the points W, S, Q, V,
 E, H, K, &c. joined by a regular curve will be
 the representation of the circle required.

Or thus.

Make the angle iak = distance of the given cir-
 cle from its parallel great circle. Then thro' the
 center of projection C, draw the great circle TCI
 parallel to the circle given, upon which erect the
 perpendicular CA = radius of projection. Also
 draw any number of right lines CV, DE, GH, IK,
 &c. perpendicular to TI. Then take each of the
 distances from A to C, D, G, I, &c. and set them
 from a to $c, g, d, i,$ &c. and to ai draw the per-
 pendiculars $cv, de, gb, ik,$ &c. and make CV,
 DE, GH, IK, &c. respectively equal to $cv, de,$
 $gb, ik,$ &c. which gives the points V, E, H, K,
 &c. after the same manner on the other side, find
 the points Q, S, W, &c. then thro' all these points
 W, S, Q, V, E, H, K, &c. draw a regular curve,
 which will be an hyperbola representing the cir-
 cle given.

Fig.

By the Scale.

48.

Take the tangent of the circle's distance from its parallel great circle, and set it from C (the center of projection) to V, and the secant thereof from C to F. Then with the semi-transverse CV, and focus F, describe the hyperbola WVHK.

P R O P. XV. *Prob.**To project any lesser oblique circle given.**Rule.*

45.

Draw the line of measures dp , and at C the center of projection draw $CA \perp$ to dp and $=$ radius of projection; with the center A, describe the circle DCFG; and draw RAE parallel to dp . Then take the greatest and least distances of the circle from the pole of projection and set from C, to D and F, for the circle DF; and from A, the projecting point, draw AFf , and Ad , then df will be the transverse axis of the ellipsis. But if D fall beyond the line RE, as at G, then draw a line from G backward thro' A to D, and then df is the transverse of an hyperbola. But if the point D fall in the line RE as at E, then the line AE no where meets the line of measures, and the projection of E is at an infinite distance, and then the circle will be projected into a parabola whose vertex is f . Lastly, bisect df in H the center, and for the ellipsis take half the difference of the lines Ad , Af , and set from H to K for the focus. But for the hyperbola take half the sum of Ad , Af , and set from H to the focus k of the hyperbola. Then with the transverse df and focus K or k describe the ellipsis dMf , or the hyperbola fm . For the projection of the circle given.

But for the parabola make $EQ = Ff$, and draw $fn \perp AQ$, and set $\frac{1}{2}nQ$ from f to K the focus. Then with

with

with the vertex f and focus k describe the parabola Fig. fm , for the projection of the given circle FE.

Otherwise by Points.

Thro' the center of projection C, draw the line of measures CF, passing thro' the pole P (if P is given; but if not, find it, by setting off CP = the distance of that pole, from the center of projection, by Prop. XI.) then set off PD, PF equal to the given distance from its pole, by Prop. XI. Thro' P draw a sufficient number of right lines, $L\lambda$, $M\mu$, Nn , Oo , Rr , Ss , &c. which will all represent great circles. Find the dividing centers of each of these lines; and by Prop. XI. set off upon each of them from P, the given distance of the circle from its pole, as PL, $P\lambda$, PM, $P\mu$, &c. and thro' all the points L, M, D, O, R, &c. draw a curve line, for the circle required.

Or thus.

Draw the line of measures PCG, and by Prop. XI. make CG = the distance of the parallel great circle from the pole of projection, and draw AGK perpendicular to it, which will represent a great circle whose pole is P. Draw any number of right lines thro' P to AK, as AP, BP, HP, &c. and by Prop. XI. set off from AK the parts AL, BM, HO, &c. each equal to the circle's distance from its parallel great circle. Then all the points L, M, D, O, &c. being joined by a regular curve, will represent the parallel circle required.

Or thus.

Thro' the center of projection C draw the line of measures DCF, and the radius of projection CW perpendicular to it, and AGK \perp GC, for a great circle whose pole is P. Draw $wp = WP$, and $wa \perp$ to it, draw any number of right lines, AP, BP, GP, &c. and make $pg, pb, pa, \&c. = PG, PB, PA,$
D &c.

Fig. &c. also make the $\angle pwl$ and $pwx =$ the circle's distance from its pole P (or $awl =$ the distance from its parallel great circle); and upon PG, PB, PA, &c. make PD, PM, PL, &c. $= pd, pm, pl,$ &c. respectively.

Or make GD, BM, AL, &c. $= gd, bm, al,$ &c. After the same manner, find the points O, R, &c. and thro' all the points R, O, D, M, L, &c. draw a regular curve, making no angles, which will represent the parallel required. Likewise where any line ap cuts wx , that distance from p will give the point λ , or is $= P\lambda$; and so of any other of the lines $bp, gp,$ &c.

The reason of this process will be plain, if you suppose the points p, w applied to P, W; and $g, b, a,$ &c. successively to G, B, A, &c. for then $d, m, l,$ will fall upon D, M, L, &c.

By the Scale.

45. Take the tangents of the circle's nearest and furthest distance from the pole of projection, and set from C to f and d , gives the vertices, and bisect df in H; then take half the difference, or half the sum, of the secants of the greatest and least distances from the pole of projection, and set from H, to K or k for the focus of the ellipsis or hyperbola, which may then be described.

49. Cor. *If the curve be required to pass thro' a given point S; measure PS by Prop. XI, and then the curve may be drawn by this Problem.*

P R O P. XVI. *Prob.*

47. *To find the pole of any circle in the projection, DMF.*

Rule.

From the center of projection C, draw the radius of projection CA perpendicular to the line of measures

fures DF. And to A the projecting point, draw Fig. DA, FA, and bisect the angle DAF by the line AP, 47. then P is the pole. But if the curve be an hyperbola, as *fm*, *fig.* 45, you must produce *dA*, and bisect the angle *fAG*. And in a parabola, where the point *d* is at an infinite distance, bisect the angle *fAE*.

Or thus; Drawing CA perpendicular to DC, draw DA, and make the angle DAP = the circle's distance from its pole, gives the pole P.

By the Scale.

Draw the radius of projection CA \perp to the line of measures DF. Apply CD CF to the tangents, and set the tangent of half the difference of their degrees from C to P, if D, F lye on contrary sides of C; but half the sum if on the same side, gives P the pole.

Or thus; By Prop. XI. set off from D to P, the circle's distance from its pole, gives the pole P.

Cor. If it be a great circle as BG; draw the line 46. of measures GC, and CA \perp to it, and equal to the radius of projection; make GAP a right angle, and P is the pole.

P R O P. XVII. *Prob.*

To measure any arch of a lesser circle; or to set any number of degrees thereon.

Rule.

Let Fn be the given circle. From the center of 46. projection C, draw CA perpendicular to the line of measures GH. To P the pole of the given circle draw AP, and AO bisecting the angle CAP. And draw AD perpendicular to AO. Describe the circle GHi (by Prop. XIII.) as far from the pole of projection C, as the given circle is from its pole P. And thro' any given point *n* in the circle Fn,

Fig. draw Dnl , gives Hl the number of degrees = F_n .

45. Or the degrees being given and set from H to l , the line Dl cuts off F_n equal thereto.

Or thus; AO being drawn as before, erect OS perpendicular to CO ; thro' the given point n draw Pn cutting OS in Q , then thro' Q draw Cl , and the angle $\angle QCP$ is = F_n . Or making $\angle QCP$ = the degrees given, draw PQn , and arch F_n = these degrees.

Or thus; AO , AP , being drawn as before, draw AG perpendicular to AP , and GB perpendicular to GC . Thro' the given point n draw PB cutting GB in B , and draw OB , then the $\angle GOB$ = arch F_n . Or making $\angle GOB$ = the given degrees; draw PB , and it cuts off F_n = the degrees given.

By the Scale.

Let C be the center of projection, P the pole of the given circle. Apply CP to the tangents, and set the tangent of its half from C to O , and the co-tangent of its half from C to D ; with radius CG = tangent of the degrees in FP the given circle's distance from its pole, describe the circle GSH . Then Dl drawn thro' n or l , cuts off Hl = F_n .

Or thus; O being found as before, erect OS perpendicular to CO ; thro' the given point n draw PQn , and $\angle QCH$ = F_n .

Or thus; Apply CP to the tangents, and set the co-tangent thereof from C to G . Erect GB perpendicular to GC . Thro' n draw PnB , and draw BO ; then $\angle GOB$ = F_n .

48. Cor. If the lesser circle be perpendicular to the plain of projection as VHK . You have no more to do but to draw the perpendiculars VC , HG , to its parallel great circle CI . Then CG (measured by Prop. XI.) will be equal to VH ; or the degrees set from C to G , cuts off VR equal thereto.

S C H O L I U M.

This sort of projection is little used, by reason of 48.
 several of the circles of the sphere fall in ellipses
 and hyperbolas, which are very difficult to describe.
 Notwithstanding it is very convenient for solving
 some Problems of the sphere, because all the great
 circles are projected into right lines. And this sort,
 or the Gnomonic Projection is the very foundation
 of all dialling. For if the sphere be projected on
 any plane, and upon that side of it on which the
 sun is to shine; and the projected pole be made
 the center of the dial, and the axis of the globe
 the Stile or Gnomon, and the radius of projection its
 height; you will have a dial drawn with all its fur-
 niture. Upon this account it deserves to be more
 taken notice of, than at present it is. I have in the
 foregoing propositions given, I think, all the fun-
 damental principles of this kind of projection, hav-
 ing met with little or nothing done upon this sub-
 ject before.

GENERAL PROBLEM.

To project the sphere upon any given plane.

Before you can project the sphere upon any plane,
 you must have a perfect knowledge of all its cir-
 cles, and their positions in respect of one another;
 the distances of the lesser circles from their poles,
 and from their parallel great circles; the angles
 made by great circles, or their inclinations, to one
 another, particularly to the primitive circle, on
 whose plane (or a parallel thereto) you are about to
 project the sphere. Then after the primitive cir-
 cle is described; you must describe all other circles
 concerned in the Problem, according to the rules
 of that sort of Projection, you are going to use;

Fig. and the intersection of these circles will determine the Problem.

And note, that the Projection of the concave side of the sphere is more fit for astronomical purposes; for in looking at the heavens, we view the concavity. But it is better to project the convex hemisphere in geography, because we see the convex side only.

The principal Points, Angles and Circles of the Sphere are as follows.

I. Points.

52. 1. *Zenith* is the point over our heads, Z.
53. 2. *Nadir* is the point under our feet, N.
55. 3. *Poles* of the world are 2 points, round which the diurnal revolution is performed, P the north pole, p the south pole. A line drawn through the poles, is called the *Axis* of the world, as Pp.
4. *The Center* of the earth or of the heavens, C.
5. *Equinoctial Points*, are the points of intersection of the Equator and Ecliptic, Υ , $\u0399$.
6. *Solstitial Points*, are the beginning of Cancer and Capricorn, ♋ , ♎ .

II. Great Circles.

1. *Equinoctial*, is a circle 90 degrees distant from the poles of the world, as EQ.
2. *Meridians*, or *hour Circles*; are circles passing thro' the poles of the world, as P \odot p, P E p, &c.
3. *Solstitial Colure*, is a meridian passing thro' the solstitial points, as P ♋ p.
4. *Equinoctial Colure*, is a meridian passing thro' the equinoctial points, P C p.
5. *Ecliptic* is the circle thro' which the sun seems to move in a year, ♋ ♎ ; it cuts the equinoctial at an angle of $23^{\circ} 30'$, in passing thro' the equinoctial points. In this are reckoned the 12 Sines, Υ , $\u0399$, ♋ , ♌ , $\u0399$, ♍ , ♎ , ♏ , $\u0399$, ♐ , ♑ , $\u0399$, ♒ .

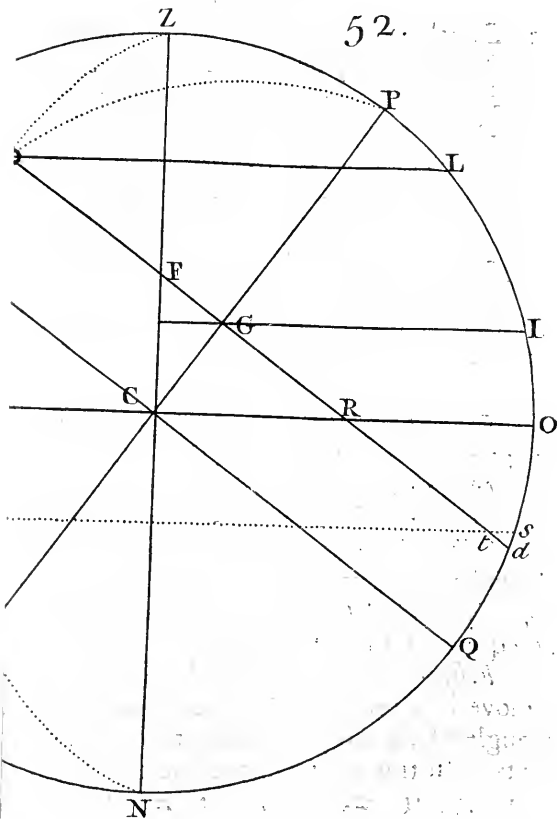
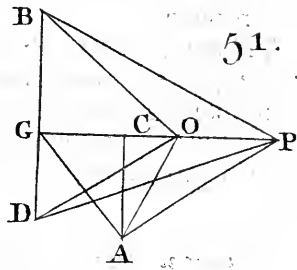
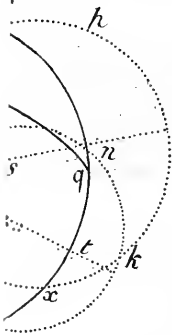

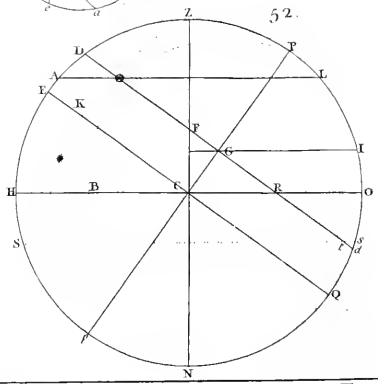
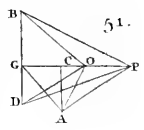
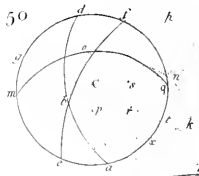

Injection

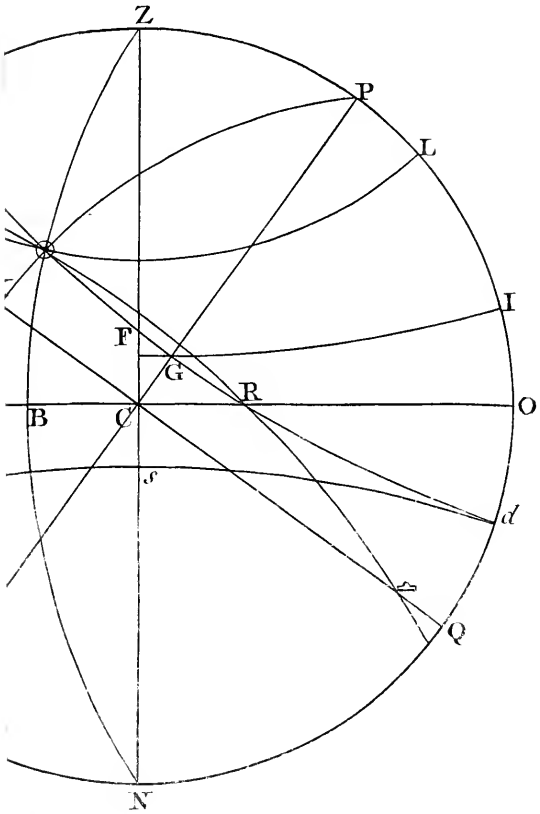

6. *Horizon*, is a circle dividing the upper from Fig. the lower hemisphere, as HO, being 90° distant 52. from the Zenith and Nadir. 53.

7. *Vertical Circles*, are circles passing thro' the 55. Zenith and Nadir, Z \odot N.

8. *Circles of Longitude* in the heavens, pass thro' the poles of the ecliptic and cut it at right angles.

9. *Meridian of a Place*, is that Meridian which passes thro' the Zenith, as PZH.

10. *Prime Vertical*, is that which passes thro' the east and west points of the horizon.

III. Lesser circles.

1. *Parallels of Latitude* are parallel to the equinoctial on the earth, *parallels of altitude* are parallel to the horizon, *parallels of declination* are parallel to the equinoctial in the heavens.

2. *Tropics*, are 2 circles distant $23^\circ 30'$ from the equinoctial, the tropic of *Cancer* towards the north, the tropic of *Capricorn* towards the south.

3. *Polar Circles*, are distant $23^\circ 30'$ from the poles of the world, the *Arctic* circle towards the north, the *Antarctic* towards the south.

IV. Angles and Arches of Circles.

1. *Sun's (or Star's) Altitude*, is an arch of the Azimuth between the sun and horizon, as \odot B.

2. *Amplitude* is an arch of the horizon, between sun-rising and the east, or sun-setting and the west.

3. *Azimuth*, is an arch of the horizon between the sun's Azimuth circle, and the north or south, as HB, or OB; or it is the angle at the zenith, HZB. or OZB.

4. *Right Ascension* is an arch of the equator between the sun's meridian, and the first point of Aries, as VK.

5. *Ascensional Difference* is an arch of the equinoctial, between the sun's meridian, and that point

Fig. of the equinoctial that rises with him, or it is the
52. angle at the pole between the sun's and the six o'clock
53. meridian.

55. 6. *Oblique Ascension* or *Descension*, is the sum or difference of the right ascension and the ascensional difference.

7. *Sun's Longitude*, is an arch of the ecliptic, between the sun and first part of Aries, as $\gamma \odot$.

8. *Declination* is an arch of the meridian, between the equinoctial and the sun, as $\odot K$.

9. *Latitude of a Star*, is an arch of a circle of longitude between the star and ecliptic.

10. *Latitude of a Plane*, in an arch of the meridian between the equinoctial and the place.

11. *Longitude* of a place on the earth is an arch of the equinoctial, between the first meridian (Isle of Ferro), and the meridian of the place. And *diff. longitude*, is an arch of the equator, between the meridians of the two places, or the angle at the pole.

12. *Hour of the Day*, is an arch of the equinoctial, between the meridian of the place and the sun's meridian, as EK; or it is the angle they make at the pole, as EPO.

Example I.

To project the sphere upon the plane of the meridian, for May 12, 1767. Latitude $54^{\circ} \frac{1}{2}$ north, at a quarter past 9 o'clock before noon.

I. By the Orthographic Projection.

52. Here we will project the convex side of the eastern hemisphere. With the chord of 60° degrees describe the primitive circle or meridian of the place HZON. Thro' the center C draw the horizon HO; set the latitude $54\frac{1}{2}$ from O to P and from H to p, and draw Pp the 6 o'clock meridian. Thro' C draw EQ perpendicular to Pp for the equinoctial. Make ED, Qd $18^{\circ} 5'$ the declination May 12, and draw Dd the sun's parallel for that day. By
Prop.

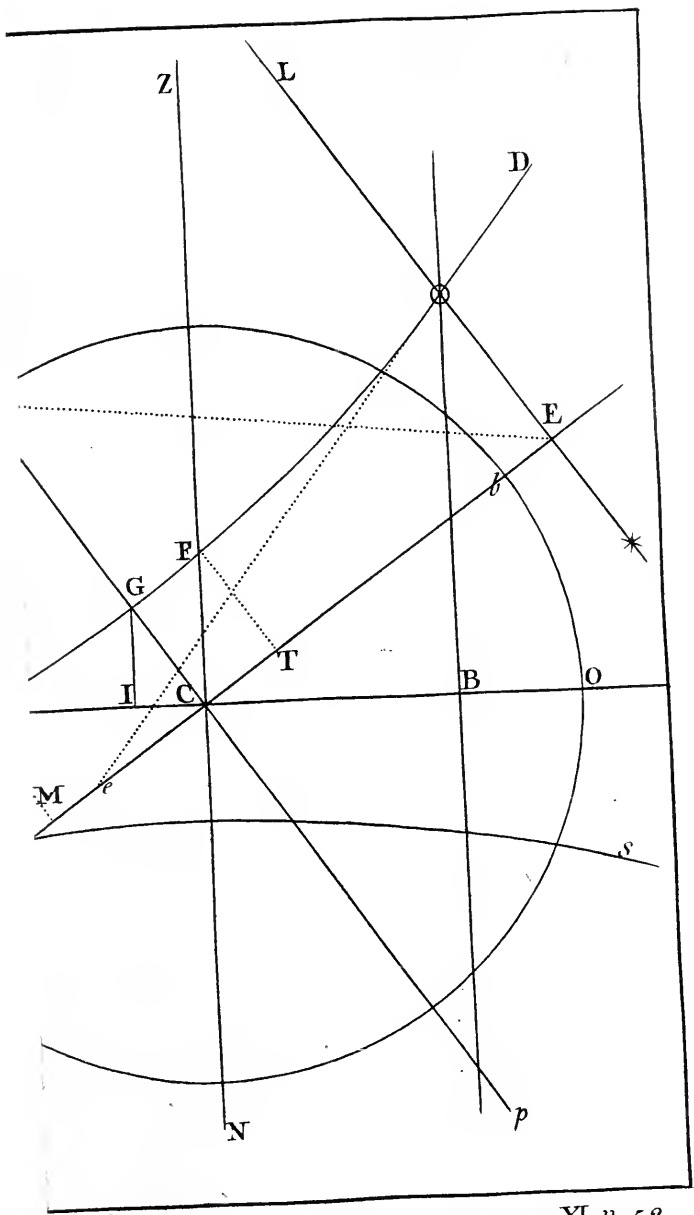

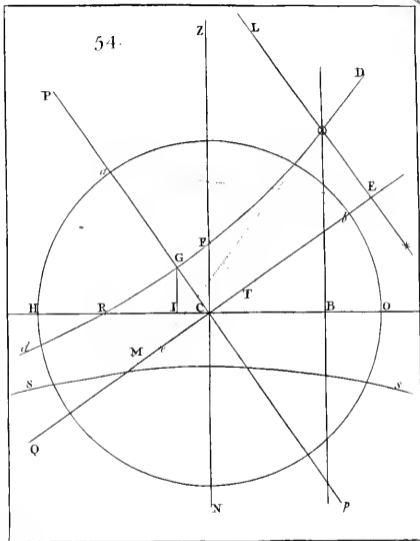

Prop. XI. make $\odot G$ ($3 \frac{1}{4}$ hours or) $48^\circ 45'$ the Fig. sun's distance from the hour of 6, then \odot is the 52. sun's place. Thro' \odot by Prop. V. draw AL parallel to $H \odot$ for the sun's parallel of altitude. By Prop. VII. draw the meridian $P \odot p$ and the azimuth $Z \odot N$. Also the ecliptic will be an ellipsis passing thro' \odot , which cannot conveniently be drawn in this projection. Also draw the parallel Ss 18° below the horizon, and where it intersects Dd is the point of day break, if there is any. Now the sun is at d at 12 o'clock at night, and rises at R , at 6 o'clock is at G , due east at F , at \odot a quarter past 9, and is at D in the meridian at 12 o'clock.

Draw GI parallel to HO . Then GR measured by Prop. X. is $27^\circ 14'$, and turned into time (allowing 15 degrees for an hour) shows how long the sun rises before 6, to be $1^h 49^m$; GI measured by Prop. X. gives the azimuth at 6, $79^\circ 16'$. CR by Cor. Prop. X. gives the amplitude $32^\circ 19'$, and CF gives his altitude when east $22^\circ 25'$. FG $13^\circ 28'$ (turned into time) is 54^m , and shews how long after 6 he is due east. IO is his altitude at 6, $14^\circ 38'$. AH $41^\circ 53'$ is his altitude at \odot , or a quarter past 9; and $\odot L$ measured by Prop. X. is his azimuth from the north at the same time, $122^\circ 40'$. And thus the place of the moon or a star being given, it may be put into the projection, as at $*$. And its altitude, azimuth, amplitude, time of rising, &c. may all be found, as before for the sun.

II. Stereographically.

To project the sphere on the plane of the meridian, the projecting point in the western point of the horizon; with cord of 60, draw the primitive circle $HZON$, and thro' C draw HO for the horizon, and ZN perpendicular thereto for the prime vertical. Set the latitude from O to P , and from H to p , and draw Pp the 6 o'clock meridian, and EQ

Fig. EQ perpendicular thereto for the equinoctial.
 53. Make ED, Qd the declination, and by Prop. XII. draw DGd, the sun's parallel for the day. Draw the meridian P ⊙ p by Prop. XVII. making an angle of $41^{\circ} 15'$ with the primitive, to intersect the sun's parallel in ⊙, the sun's place at $9^{\text{h}} \frac{1}{4}$. Thro' ⊙, by Prop. XII. draw the parallel of altitude A ⊙ L; thro' ⊙ draw, by Prop. XVII. the azimuth Z ⊙ N. And by Prop. XII. draw the parallel Ssd 18° below the horizon, if it cut Rd, gives the point of day break. And thro' G draw the parallel of altitude GI. Lastly, by Prop. XX. thro' ⊙ draw the great circle $\gamma \odot \simeq$ cutting the equinoctial EQ at an angle of $23^{\circ} : 30'$, and this is the ecliptic, γ the first point of Aries, and \simeq that of Libra.

This done, dR measured by Prop. XXIII. is $62^{\circ} 46'$, shows the time of sun rising; CR by Prop. XXII. is the amplitude $32^{\circ} 19'$. GI $79^{\circ} 16'$ by Prop. XXIII. the sun's azimuth at 6. IO $14^{\circ} 38'$ his altitude at 6. CF $22^{\circ} 25'$ by Prop. XXII. his altitude when east. GF $13^{\circ} 28'$ the time when he is due east. ⊙B $41^{\circ} 53'$ by Prop. XXII. his altitude at a quarter past 9; the $\sphericalangle \odot ZP$ $122^{\circ} 40'$ by Prop. XXIV. his azimuth at that time. Also $\gamma \odot$, by Prop. XXII. is his longitude $51^{\circ} 7'$. γK his right ascension, $48^{\circ} 40'$.

And the place of the moon or a star being given, it may be put into the scheme as at *; and its time of rising, amplitude, azimuth, &c. found as before.

III. Gnomonically.

54. To project the eastern hemisphere upon a plane parallel to the meridian. About the center of projection C describe the circle HON with the tangent of 45 the radius of projection, for the primitive. Thro' C draw the horizon HIO, and the prime vertical

tical ZN perpendicular thereto. Set the latitude Fig. 54. $54\frac{1}{2}$ from H to *a*, and draw the 6 o'clock meridian *Pp*, and the equino&ctial EQ perpendicular to it. Set the tangent of $48^{\circ} 45'$ (equal to $3\frac{1}{4}$ hours) from C to E, and by Prop. X. draw the meridian EL parallel to *Pp*. Make $Ee = Ea$, and $\angle Ee\odot = 18^{\circ} 5'$ the sun's declination, then by Prop. XI. \odot is the sun's place. Thro' \odot draw the hyperbola $D\odot d$ (by Prop. XIV.) for the sun's parallel of declination; and draw $\odot B$ perpendicular to HO, for his azimuth circle. And draw GI perpendicular to HO, and RM, FT, $\parallel Pp$. Also the ecliptic is a right line passing thro' \odot , and cutting EQ at an angle of $23^{\circ} 30'$, which is difficult to draw in this projection.

Also by Prop. XIV. Draw the parallel *Ss* 18° below the horizon, and if it intersects *Dd*, it gives the point of sun rise.

Then if by Prop. XVII. or XI. you measure GR or rather CM, $27^{\circ} 14'$, you have the time of sun rising; GF or CT $13^{\circ} 28'$, the time when he is due east. Also by Prop. XI. if you measure CR you have the amplitude $32^{\circ} 19'$. CI the comp. of his azimuth at six, $10^{\circ} 44'$. IG by Prop. XII. his altitude at 6, $14^{\circ} 38'$. CF his altitude when east, $22^{\circ} 25'$. And by Prop. XI. $\odot B = 41^{\circ} 53'$, his altitude a quarter past 9. CB the complement of his azimuth at that time, $32^{\circ} 40'$.

And the place of the moon or a star being given, its place in the projection may be determined as before, and all the requisites found.

Ex. 2.

To project the sphere upon the plane of the solstitial colure for latitude $54\frac{1}{2}$ N. May 23, 1767, at 10 o'clock in the morning.

Fig.

55.

Stereographically.

The projection of the western hemisphere, the first point of Libra, the projecting point. Describe the solstitial colure $PEpQ$, and the equinoctial colure Pp perpendicular to it; and thro' C draw the equinoctial EQ perpendicular to Pp . Set $23^{\circ} 30'$ from E to \mathfrak{S} , and from Q to \mathfrak{V} , and draw the ecliptic $\mathfrak{S}\mathfrak{V}$. Set the sun's longitude $61^{\circ} 42'$ from C to \odot , and thro' \odot draw $P\odot Kp$ for the 10 o'clock meridian. Make KA (two hours or) 30° , and draw PAp for the meridian of the place. Set the latitude of the place $54\frac{1}{2}$ from A to Z , and Z is the zenith. About the pole Z describe the great circle BHS for the horizon of the place. Thro' Z and \odot draw an azimuth circle $Z\odot B$.

Then you have $\odot K$ the sun's declination $20^{\circ} 33'$. CK his right ascension $59^{\circ} 35'$. $\odot B$ his altitude at 10 o'clock $49^{\circ} 10'$; the $\angle AZ\odot$ or $PZ\odot$ his azimuth at 10 = HB , $45^{\circ} 44'$. H the south point of the horizon. I the point of the ecliptic that is in the meridian. T the point of the ecliptic that is setting in the horizon.

Example. 3.

To project the sphere on the plane of the horizon, Lat. $35\frac{1}{2}$, N. July 31, 1767, at 10 o'clock.

Gnomonically.

56. To project the upper hemisphere on a plane parallel to the horizon. With the radius of projection and center C , describe the primitive circle ADB . Thro' C draw the meridian PE , and AS perpendicular to it for the prime vertical. Set off CP $35\frac{1}{2}$ the latitude and P is the N. Pole, and perpendicular to CP draw Pp the 6 o'clock meridian. Set the complement of the latitude from C to E ; and draw EQ perpendicular to CE for the equinoctial.

v. last.

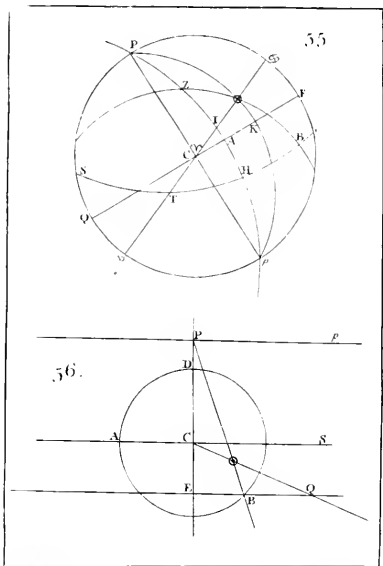

equinoctial. Make EB 30° (or 2 hours) and draw Fig. the 10 o'clock meridian PB . Set the sun's declina- 50. tion $18^\circ 27'$ from B to \odot . And \odot is the place of the sun at 10 o'clock. Thro' O draw the azimuth circle CQ ; likewise thro' \odot , a parallel to the equinoctial EQ may easily be described by Prop. XV. for the sun's parallel that day.

Then $C\odot$ measured by Prop. XI. is $31^\circ 30'$ the complement of the altitude. And the angle $EC\odot$ measured by Cor. Prop. XII. is his azimuth, $65^\circ 10'$.

SCHOLIUM.

After this manner may any Problems of the Sphere be solved by any of these Projections, or upon any planes, but upon some more commodiously than upon others. And if in a spherical triangle any sides or angles be required, they may be projected according to what is given therein, according to any of these kinds of projection before delivered; and it will be most easily done, when you chuse such a plane to project on, that some given side may be in the primitive, or a given angle at the center; and then you need draw no more lines or circles than what are immediately concerned in that Problem. But always chuse such a plane to project on, where the lines and circles are most easily drawn, and so that none of them run out of the scheme.

F I N I S.

E R R A T A.

b signifies reckon from the bottom.

pag	line	read
5	1	fig. 2.
8	18	fig. 5.
9	3b	off the fines,
13	17	fig. 12.
14	2b	the 2 last lines should be indented and roman.
	21	$CpA + CAP$;
15	3	the 3d line should be indented, and the 3 following lines roman.
16	5	$ECI = CAD$
18	4	if, p , q , be
20	7	projection C,
21	15	$OG + OD$:
		2
25	9b	points A, B, G,
29	6b	interfection p ,
30	2	gCr required.
	11b	pole p , draw
33	17	of this circle
36	6b	TV, and
	2b	at s cut
38	2b	to sS ;
43	2	$CL = \text{radius}$
44	20	A to d ,

T H E
L A W S
O F

Centripetal and Centrifugal F O R C E.

S H E W I N G,

The M O T I O N of B O D I E S in Circular Orbits, and
in the Conic Sections, and other Curves.

And explaining the perturbing Force of a third
Body. With many other Things of like Nature.

Being a Work preparatory to ASTRONOMY, and
the very Basis thereof. And absolutely necessary
to be known by all such as desire to be Profi-
cients in that S C I E N C E.

*Solis uti varios cursus, lunæque meatus
Noscere possemus, quæ vis, & causa cieret*

LUCRET. Lib. V.

T H E

P R E F A C E.

*I*N the following Treatise, I have explained and demonstrated the Laws of Centripetal Forces; a doctrine upon which all Astronomy is grounded; and without the knowledge of which, no rational account can be given of the motions of any of the celestial bodies, as the Comets, the Planets, and their Satellites. From these laws are derived the causes of the various seeming irregularities observed in their motions; such as their accelerations and retardations, their approaching to, and receding from the center of force; irregularity, only in appearance; but in reality, these motions are truly regular and conformable to the established laws of Nature. From this foundation we trace the way or path of all the planets, and discover the origin and spring of all the celestial motions, and clearly understand and account for all the phænomena thence arising.

In the first section, you have the Centripetal Forces of bodies revolving in circles; their velocities, periodic times, and distances compared together; their relations and proportions to each other; and that when they either revolve about the same center, or about different ones. The different motions caused by different forces, or by different central attracting bodies, are here shewn. We have given likewise the periodic time of a simple pendulum revolving with a conical motion; and also the center of Turbination, and the periodic time of a compound pendulum, or a system of bodies, revolving with a conical motion; as properly belonging to the doctrine of Centripetal Forces.

In the second section we have shewn the motion of bodies in the Ellipsis, Hyperbola, and Parabola; and in other Curves. The proportion of the Centripetal Forces, and velocities in different parts of the same Curve. The law of Centripetal Force to describe a given Curve, and the velo-

city in any point of it; and more particularly with respect to that law of Centripetal Force that is reciprocally as the square of the distance; which is the grand law of Nature in regard to the action of bodies upon one another at a distance; and according to this law, is shewn the motion of bodies round one another, and round their common center of gravity, and the orbits they will describe.

In the third section we have given the disturbing or perturbing force of a third body, acting upon two others that revolve round one another. From these principles are deduced the errors caused in the motion of a Satellite, moving round its primary planet. Towards the end, are several propositions, by means whereof, the motion of the Nodes, and variation of inclination of a Satellite's orbit, and such like things may be computed. As these things are all laid down for the sake of understanding our own System, I have inserted some few things, by way of illustration of the rules, in regard to the Moon and Jupiter. But as to the Moon, there are some things so very intricate, and require such long and tedious calculations, as would require a volume of themselves; so that the small room I am confined to cannot admit of them; and few would trouble themselves to read them, if they were there. This last section concludes with a few things of another kind, but depending on the principles of Centripetal Forces.

Several of these things about Centripetal Forces are calculated by the method of Fluxions; and cannot easily be done any other way; and most of them taken from my book of Fluxions. And several other things relating to Centripetal Forces, you will also find in that book; being sorry to trouble the reader too much with repeating what I have written and published elsewhere.

W. Emerson.

T H E
L A W S
O F

Centripetal and Certrifugal FORCE.

D E F I N I T I O N S.

D E F. I.

THE center of attraction, is the point towards which any body is attracted or impelled.

D E F. II.

Centripetal force, is that force by which a body is impelled to a certain point, as a center. Here all the particles of the body are equally acted on by the force.

D E F.. III.

Centrifugal force, is the resistance a moving body makes to prevent its being turned out of its direct course. This is opposite and equal to the centripetal force; for action and re-action are equal and contrary.

D E F. IV.

Angular velocity, is the quantity of the angle a body describes in a given time, about a certain point, as a center. *Apparent velocity* is the same thing.

D E F. V.

Periodical time, is the time of revolution of a body round a center.

S E C T. I.

The motion of bodies in Circular ORBITS.

P R O P. I.

Fig. *The centripetal forces, whereby equal bodies at equal distances from the centers of force, are drawn towards these centers; are as the quantities of matter in the central bodies.*

For since all attraction is made towards bodies, every part of the attracting body must contribute its share in that effect. Therefore a body twice as great will attract the same body twice as much; and one thrice as great, thrice as much, and so on. Therefore the attraction of the central body; that is, the centripetal force, is as the quantity of matter in the attracting or central body.

Cor. 1. *Any body whether great or little, placed at the same distance, is attracted thro' equal spaces in the same time, by the central body.*

For tho' a body twice or thrice as great as another, is drawn with twice or thrice the force; yet it will acquire no greater velocity, nor pass thro' a greater space. For (Prop. V. Cor. 2. Mechan.) the velocity generated in a given time, is as the force directly, and quantity of matter reciprocally; and the force, which is the weight of the body, being as the quantity of matter; therefore the velocity generated is as the quantity of matter directly, and quantity of matter reciprocally, and therefore is a given quantity.

Cor.

Cor. 2. Therefore the centripetal force, or force Fig.
towards the center, is not to be measured by the quantity of the falling body; but by the space it falls thro' in a given time. And therefore it is sometimes called an accelerative force.

P R O P. II.

If a body revolves in a circle, and is retained in it, 1.
by a centripetal force, tending to the center of it; put
 $R =$ radius of the circle or orbit described, AC .

$F =$ absolute force, at the distance R .

$s =$ the space, a falling body could descend thro', by the force at A , and

$t =$ time of the descent.

$\pi = 3.1416$.

Then its periodic time, or the time of one revolution

will be $\pi t \sqrt{\frac{2R}{s}}$.

And the velocity, or space it describes in the time t , will be $\sqrt{2Rs}$.

For let AB be a tangent to the circle at A ; take AF an infinitely small arch, and draw FB perp. to AB , and FD perp. to the radius AC . Let the body descend thro' the infinitely small height AD or BF , by the centripetal force in the time t . Now that the body may be kept in the circular orbit AFE , it ought to describe the arch AF in the same time t . The circumference of the circle AE is $2\pi R$, and the arch $AF = \sqrt{2R \times AD}$.

By the laws of falling bodies $\sqrt{s} : t :: \sqrt{AD} :$

$t \sqrt{\frac{AD}{s}} =$ time of moving thro' AD or AF . And

by uniform motion, as AF , to the time of its description :: circumference $AFEA$, to the time of

Fig.

1. one revolution; that is, $\sqrt{2R \times AD} : t \sqrt{\frac{AD}{s}} ::$

$$2\pi R : \text{periodic time} = \frac{2t\pi R}{\sqrt{2Rs}} = \pi t \sqrt{\frac{2R}{s}}.$$

Also by the laws of uniform motion, $t \sqrt{\frac{AD}{s}}$ or time of describing AF : AF or $\sqrt{2R \times AD} :: t : \sqrt{2Rs} =$ the velocity of the body, or space described in time t .

Cor. 1. *The velocity of the revolving body, is equal to that which a falling body acquires in descending thro' half the radius AC, by the force at A uniformly continued.*

For \sqrt{s} (height) : $2s$ (the velocity) :: $\sqrt{\frac{1}{2}R}$ (the height) : $\sqrt{2Rs}$, the velocity acquired by falling thro' $\frac{1}{2}R$.

Cor. 2. *Hence, if a body revolves uniformly in a circle, by means of a given centripetal force; the arch which it describes in any time, is a mean proportional between the diameter of the circle, and the space which the body would descend thro' in the same time, and with the same given force.*

For $2R$ (diameter) : $\sqrt{2Rs} :: \sqrt{2Rs} : s$; where $\sqrt{2Rs}$ is the arch described, and s the space descended thro', in the time t .

2. Cor. 3. *If a body revolves in any curve AFQ, about the center of force s ; and if AC or R be the radius of curvature in any point A; $s =$ space descended by the force directed to C. Then the velocity in A will be $\sqrt{2Rs}$.*

For this is the velocity in the circle; and therefore in the curve, which coincides with it.

P R O P.

PROP. III.

If several bodies revolve in circles round the same or different centers; the periodic times will be as the square roots of the radii directly, and the square roots of the centripetal forces reciprocally.

1.

Let F = centripetal force at A tending to the center C of the circle.

V = velocity of the body.

R = radius AC of the circle,

P = periodic time.

Then (Prop. II.) $P = \pi t \sqrt{\frac{2R}{s}}$. But s is as the force F that generates it; whence $P = \pi t \sqrt{\frac{2R}{F}}$, and since π , t and F are given quantities, therefore $P \propto \sqrt{\frac{R}{F}}$.

Cor. 1. *The periodic times are as the radii directly, and the velocities reciprocally.*

For (Prop. II.) $V = \sqrt{2Rs} = \sqrt{2RF}$, and $V^2 = 2RF$, and $P = \pi t \sqrt{\frac{2R}{F}}$, and $PP = \pi^2 t^2 \times \frac{2R}{F}$, therefore $P^2 V^2 = \pi^2 t^2 \times 4R^2$, and $P^2 = \frac{\pi^2 t^2 \times 4R^2}{V^2}$, and $P = \frac{\pi t \times 2R}{V} \propto \frac{R}{V}$.

Cor. 2. *The periodic times are as the velocities directly, and the centripetal forces reciprocally.*

For $V^2 = 2Rs = 2RF$; and $R = \frac{VV}{2F}$, and $\frac{R}{V} = \frac{V}{2F} \propto \frac{V}{F}$. But (Cor. 1.) $P \propto \frac{R}{V} \propto \frac{V}{F}$.

6 CENTRIPETAL FORCES.

Fig. Cor. 3. *If the periodic times are equal; the velocities, and also the centripetal forces, will be as the radii.*

For if P be given; then $\frac{R}{F}$, and $\frac{R}{V}$, and $\frac{V}{F}$ are all given ratios.

Cor. 4. *If the periodic times are as the square roots of the radii; the velocities will be as the square roots of the radii, and the centripetal forces equal.*

For (Prop. III. and Cor. 1.) putting \sqrt{R} for P, we have $\sqrt{R} \propto \sqrt{\frac{R}{F}} \propto \frac{R}{V}$. Therefore $1 \propto \frac{1}{\sqrt{F}} \propto \frac{\sqrt{R}}{V}$, and $\sqrt{R} \propto V$, and \sqrt{F} is a given quantity.

Cor. 5. *If the periodic times are as the radii; the velocities will be equal, and the centripetal forces reciprocally as the radii.*

For putting R for P, we have $R \propto \sqrt{\frac{R}{F}} \propto \frac{R}{V}$; whence $\sqrt{R} \propto \frac{1}{\sqrt{F}}$, and $1 \propto \frac{1}{V}$; that is, $R \propto \frac{1}{F}$, or the centripetal force is reciprocally as the radius; and V is a given quantity.

Cor. 6. *If the periodic times are in the sesquiplicate ratio of the radii; the velocities will be reciprocally as the square roots of the radii, and the centripetal forces reciprocally as the squares of the radii.*

Put $R^{\frac{3}{2}}$ for P, then $R^{\frac{3}{2}} \propto \sqrt{\frac{R}{F}} \propto \frac{R}{V}$; and $R \propto \frac{1}{\sqrt{F}}$ or $RR \propto \frac{1}{F}$, and $\sqrt{R} \propto \frac{1}{V}$.

Cor. 7. *If the periodic times be as the nth power of the radius; then the velocities will be reciprocally as the n — 1th power of the radii, and the centripetal forces*

forces reciprocally as the $2n - 1^{\text{th}}$ power of the radii. Fig. 1.

Put R^n for P , then $R^n \propto \sqrt{\frac{R}{F}} \propto \frac{R}{V}$. Whence $R^{2n} \propto \frac{R}{F}$, and $R^{2n-1} \propto \frac{1}{F}$. Also $R^{n-1} \propto \frac{1}{V}$.

P R O P. IV.

If several bodies revolve in circles round the same or different centers; the velocities are as the radii directly, and periodic times reciprocally. 1.

For putting the same letters as in Prop. III. we have (by Prop. II.) $V = \sqrt{2R\dot{s}} = \sqrt{2RF}$; and $P \propto \frac{V}{F}$ (by Cor. 2. Pr. III.), and $PF \propto V$, and $F \propto \frac{V}{P}$. Whence $V = \sqrt{2RF} = \sqrt{2R \times \frac{V}{P}}$, and $V^2 = \frac{2RV}{P}$, and $V = \frac{2R}{P} \propto \frac{R}{P}$.

Cor. 1. *The velocities are as the periodical times, and the centripetal forces.*

For we had $PF \propto V$.

Cor. 2. *The squares of the velocities are as the radii and the centripetal forces.*

For $V = \sqrt{2RF}$.

Cor. 3. *If the velocities are equal; the periodic times are as the radii, and the radii reciprocally as the centripetal forces.*

For if V be given, its equal $\frac{R}{P}$ is a given ratio; and \sqrt{RF} is given, whence $R \propto \frac{1}{F}$.

Fig. Cor. 4. *If the velocities be as the radii, the periodic times will be the same; and the centripetal forces as the radii.*

For then V or $R \propto \frac{R}{P}$, and $t \propto \frac{1}{P}$. Also $R = \sqrt{2RF}$, whence $R \propto F$.

Cor. 5. *If the velocities be reciprocally as the radii; the centripetal forces are reciprocally as the cubes of the radii; and the periodic times as the squares of the radii.*

For put $\frac{1}{R}$ for V , then (Cor. 2.) $\frac{1}{R} = \sqrt{2RF}$,
 $\frac{1}{RR} = 2RF$, whence $F \propto \frac{1}{R^3}$. Also $\frac{1}{R} \propto \frac{R}{P}$, and
 $P \propto RR$.

P R O P. V.

1. *If several bodies revolve in circles about the same or different centers; the centripetal forces are as the radii directly, and the squares of the periodic times reciprocally.*

Put the same letters as in Prop. III. Then (Prop. II.) $P = \pi t \sqrt{\frac{2R}{s}} = \pi t \sqrt{\frac{2R}{F}}$, and $PP = \pi\pi t t \times \frac{2R}{F}$, and $PPF = 2\pi\pi t t R$; whence $F = \frac{2\pi\pi t t R}{PP} \propto \frac{R}{PP}$.

Cor. 1. *The centripetal forces are as the velocities directly, and the periodic times reciprocally.*

For (Prop. IV.) $V \propto \frac{R}{P}$, and $F \propto \frac{R}{PP} \propto \frac{V}{P}$.

Cor. 2. *The centripetal forces, are as the squares of the velocities directly, and the radii reciprocally.*

For

For (Cor. 1.) $F \propto \frac{V}{P}$, and $FP \propto V$. But (Prop.

III. Cor. 1.) $P \propto \frac{R}{V}$, therefore $FP \propto \frac{FR}{V}$, therefore $\frac{FR}{V} \propto V$, and $F \propto \frac{VV}{R}$.

Cor. 3. *If the centripetal forces are equal; the velocities are as the periodic times; and the radii as the squares of the periodic times, or as the squares of the velocities.*

Cor. 4. *If the centripetal forces be as the radii, the periodic times will be equal.*

For $F \propto \frac{R}{PP}$, and $\frac{F}{R} \propto \frac{1}{PP}$, and if $\frac{F}{R}$ be a given ratio, $\frac{1}{PP}$ will be given, as also P.

Cor. 5. *If the centripetal forces be reciprocally as the squares of the distances; the squares of the periodical times will be as the cubes of the distances; and the velocities reciprocally as the square roots of the distances.*

For writing $\frac{1}{RR}$ for F, then $\frac{1}{RR} \propto \frac{R}{PP}$, and $\frac{R}{PP^2}$ a given quantity. And $\frac{1}{RR} \propto \frac{VV}{R}$, and $\frac{1}{R} \propto VV$, or $\sqrt{\frac{1}{R}} \propto V$.

P R O P. VI.

If several bodies revolve in circles, about the same or different centers; the radii are directly as the centripetal forces, and the squares of the periodic times.

For (Prop. II.) putting the same letters as before, $P = \pi t \sqrt{\frac{2R}{s}} = \pi t \sqrt{\frac{2R}{F}}$, and $PP = \pi \pi t t \times \frac{2R}{F}$, and $PPF = 2\pi \pi t t R \propto R$.

Cor.

Fig. Cor. 1. *The radii are directly as the velocities and
1. periodic times.*

For (Prop. IV. Cor. 1.) $PF \propto V$, but $PPF \propto R$; therefore $PV \propto R$.

Cor. 2. *The radii are as the squares of the velocities directly, and the centripetal forces reciprocally.*

For (Prop. III. Cor. 2.) $P \propto \frac{V}{F}$, but (Cor. 1.)
 $R \propto PV$; therefore $R \propto \frac{VV}{F}$.

Cor. 3. *If the radii are equal; the centripetal forces are as the squares of the velocities, and reciprocally as the squares of the periodic times. And the velocities reciprocally as the periodic times.*

For if R be given, $\frac{VV}{F}$, and PPF , and PV , are given quantities, and $F \propto VV$, or $F \propto \frac{I}{PP}$, and $V \propto \frac{I}{P}$.

SCHOLIUM.

The converse of all these propositions and corollaries are equally true. And what is demonstrated of centripetal forces, is equally true of centrifugal forces, they being equal and contrary.

PROP. VII.

1. *The quantities of matter in all attracting bodies, having others revolving about them in circles; are as the cubes of the distances directly, and the squares of the periodical times reciprocally.*

Let M be the quantity of matter in any central attracting body. Then since it appears, from all astronomical observations, that the squares of the periodical times are as the cubes of the distances, of the planets, and satellites from their respective centers.

SECT. I: CENTRIPETAL FORCES.

centers. Therefore (Cor. 6. Prop. III.) the centripetal forces will be reciprocally as the squares of the distances; that is, $F \propto \frac{1}{RR}$. And (Prop. I.) the attractive force at a given distance, is as the body M, therefore the absolute force of the body M is as $\frac{M}{RR}$. And (Prop. V.) since $F \propto \frac{R}{PP}$, put $\frac{M}{RR}$ instead of F, and we have $\frac{M}{RR} \propto \frac{R}{PP}$, and $M \propto \frac{R^3}{P^2}$.

Fig. 1.

Cor. 1. Hence instead of F in any of the foregoing propositions and their corollaries, one may substitute $\frac{M}{RR}$, which is the force that the attracting body in C, exerts at A.

Cor. 2. The attractive force of any body, is as the quantity of matter directly, and the square of the distance reciprocally.

Cor. 3. If the centripetal force be as the distance from the center C. A body let fall from any point A, will fall to the center in the same time, that a body revolving in the circular orbit ALEA, at the distance CA, would describe the quadrant AGL.

Cor. 4. The truth of this is very readily shewn by fluxions; thus, put $AC = r$, $AH = x$, $t =$ time of describing AH, $v =$ the velocity at H. $F =$ force at H, which is as CH or $r - x$. Then (Mechan. Cor. 2. Prop. V.) the velocity generated is as the force and time; that is, $v \propto F t$. Also (Mechan. Prop. III. Cor. 1.) the time is as the space divided by the velocity;

P R O P. VIII.

The truth of this is very readily shewn by fluxions; thus, put $AC = r$, $AH = x$, $t =$ time of describing AH, $v =$ the velocity at H. $F =$ force at H, which is as CH or $r - x$. Then (Mechan. Cor. 2. Prop. V.) the velocity generated is as the force and time; that is, $v \propto F t$. Also (Mechan. Prop. III. Cor. 1.) the time is as the space divided by the velocity;

Cor. 1. The truth of this is very readily shewn by fluxions; thus, put $AC = r$, $AH = x$, $t =$ time of describing AH, $v =$ the velocity at H. $F =$ force at H, which is as CH or $r - x$. Then (Mechan. Cor. 2. Prop. V.) the velocity generated is as the force and time; that is, $v \propto F t$. Also (Mechan. Prop. III. Cor. 1.) the time is as the space divided by the velocity;

ty;

Fig. 3. ty; that is, $t \propto \frac{\dot{x}}{v}$; therefore $\dot{v} \propto \frac{F\dot{x}}{v} \propto \frac{r-x \times \ddot{x}}{v}$,

and $v\dot{v} \propto r-x \times \dot{x}$, and the fluent is $\frac{vv}{2} \propto rx -$

$\frac{xx}{2}$, or $vv \propto 2rx - xx$, and $v \propto \sqrt{2rx - xx}$ or HG; that is, the velocity at H is as the ordinate HG of the circle.

Now it is evident, that in the time the revolving body describes the infinitely small arch AF, the falling body will descend thro' the versed sine AD, and would describe twice AD in the same time, with the velocity in D. Therefore we shall have,

velocity at F : velocity at D :: AF or FD : 2AD,
and velocity at D : velocity at H :: AF or FD : GH,

therefore,

velocity at F or G : velocity at H :: AF² : 2AD × GH :: $\frac{AF^2}{2AD}$: GH :: CA or CG : GH. But

drawing an ordinate infinitely near GH; by the nature of the circle, it will be, as GC : GH :: fo the increment of the curve AG : to the increment of the axis AH. And therefore, vel. at G : vel. at H :: as the increment of AG : to the increment of AH. Therefore since the velocities are as the spaces described, the times of description will be equal; and the several parts of the arch AGL are described in the same times as the correspondent parts of the radius AHC. And by composition, the arch AG and abscissa AH, as also the quadrant AL and radius AC, are described in equal times.

Cor. 1. *The velocity of the descending body at any place H, is as the sine GH.*

Cor. 2. *And the time of descending thro' any versed sine AH, is as the corresponding arch AG.*

Cor.

Cor. 3. *All the times of falling from any altitudes whatever, to the center C, will be equal.* Fig. 3.

For these times are $\frac{1}{4}$ the periodic times; and (Prop. V. Cor. 4.) these periodic times are all equal.

Cor. 4. *In the time of one revolution, the falling body will have moved thro' C to E, and back again thro' C to A, meeting the revolving body again at A.*

Cor. 5. *The velocity of the falling body at the center C, is equal to the velocity of the revolving body.*

For the velocities are as the lines GH and GC; and these are equal, when G comes to L.

P R O P. IX.

If a pendulum AB be suspended at A, and be made to revolve by a conical motion, and describe the circle BEDH parallel to the horizon. 4.

Put $\pi = 3.1416$; $p = 16\frac{1}{2}$ feet, the space descended by gravity in the time t .

Then the periodical time of B will be $\pi t \sqrt{\frac{2AC}{p}}$.

For (Mechan. Prop. VIII.) if the axis AC represents the weight of the body, AB will be the force stretching the string, and BC the force tending to the center C. Also (Mechan. Prop. VI.) if the time is given, the space described will be as the

force; whence $AC : BC :: p :: \frac{BC}{AC} p =$ the space descended towards C, by the force BC, in the time t . This is the space s in Prop. II. Therefore instead of s put its value in the periodical time, and (by Prop. II.) we shall have the periodical time of the

$$\begin{aligned} \text{pendulum} &= \pi t \sqrt{\frac{2R}{s}} = \pi t \sqrt{2BC \times \frac{AC}{BC \times p}} \\ &= \pi t \sqrt{\frac{2AC}{p}}. \end{aligned}$$

Cor.

Fig. 4. Cor. 1. *In all pendulums, the periodic times are as the square roots of the heights of the cones, AC.*

For π , t , and p are given quantities.

Cor. 2. *If the heights of the cones be the same, the periodic times will be the same, whatever be the radius of the base BC.*

Cor. 3. *The semiperiodic time of revolution, is equal to the time of oscillation of a pendulum, whose length is AC, the height of the cone.*

For by the laws of falling bodies, $t \sqrt{\frac{AC}{2p}} =$ time of falling thro' $\frac{1}{2} AC$; and therefore (Mechan. Prop. XXIV.) $1 : \pi : : t \sqrt{\frac{AC}{2p}} : \pi t \sqrt{\frac{AC}{2p}} = \frac{1}{2} \pi t \sqrt{\frac{2AC}{p}}$, the time of vibration, which is half the periodical time.

Cor. 4. *The space descended by a falling body, in the time of one revolution, will be $\pi \pi \times 2AC$.*

For tt (time) : p (height) : : $\pi \pi tt \times \frac{2AC}{p}$ (per. time) : $\pi \pi \times 2AC =$ height descended in that time.

Cor. 5. *The periodic time, or time of one revolution, is equal to $\pi \sqrt{2} \times$ time of falling thro' AC.*

For the time of falling thro' AC is $t \sqrt{\frac{AC}{p}}$.

Cor. 6. *The weight of the pendulum is to the centrifugal force; as the height of the cone AC, to the radius of the base CB. And therefore when the height CA is equal to the radius CB; the centripetal or centrifugal force is equal to the gravity.*

P R O P. X.

Suppose a system of bodies A, B, C, to revolve 5.
with a conical motion about the axis TR perp. to the
horizon, so as to keep the same side always towards
the axis of revolution, and the same position among
themselves.

To find the periodical time of the whole system.

1. Let A, B, C be all situated in one plane
passing thro' TR. From A, B, C let fall the
perpendiculars Aa, Bb, Cc, upon the axis TR.
And let A, B, C represent the quantities of matter
in the bodies A, B, C. Also put $b = 16\frac{1}{2}$ feet,
the hight a body falls in the time t by gravity; π
 $= 3.1416$; P = the periodic time of the system.

By the resolution of forces, Ta (gravity) : Aa
(force in direction Aa) :: $b : \frac{Aa}{Ta} b =$ space de-
scended by A towards a in the time 1, which is as
the velocity generated by the force Aa. There-
fore $\frac{Aa}{Ta} bA =$ motion generated in A in direction
Aa. And the force in direction Aa to move the
system towards TR, by the power of the lever
TA, is $\frac{Aa}{Ta} bA \times Ta$ or $Aa \times bA$. This is the
centripetal force of the system, arising from the gra-
vity of A. In like manner the centripetal forces
arising from B and C, will be $Bb \times bB$ and $Cc \times bC$.

By the laws of uniform motion, $P : 2\pi \times Aa ::$
 $t : \frac{2\pi t \times Aa}{P} =$ arch described by A in the time
 t . And $\frac{4\pi\pi t t \times Aa^2}{PP \times 2Aa}$ or $\frac{2\pi\pi t t \times Aa}{PP} =$ distance it
is drawn from the tangent in that time, or as the
velocity generated; and therefore $\frac{2\pi\pi t t \times Aa}{PP} \times A$
=

Fig. = motion of A tending from the center a , by the revolution of the system. And the force in direction aA , to move the system from TR, by the

power of the lever TA, will be $\frac{2\pi\pi t t \times Aa}{PP}$ $A \times$

Ta . And this is the centrifugal force of the system arising from the revolution of A. And in like manner the centrifugal forces arising from B and

C, will be $\frac{2\pi\pi t t \times Bb}{PP}$ $B \times Tb$, and $\frac{2\pi\pi t t \times Cc}{PP}$ $C \times Tc$.

But because the whole system always keeps at the same distance from the axis TF, in its revolution; therefore the sum of all the centripetal forces must be equal to the sum of all the centrifugal forces. Whence $Aa \times bA = Bb \times bB + Cc \times bC = \frac{2\pi\pi t t}{PP} \times$ into $Aa \times Ta \times A + Bb \times Tb \times B + Cc$

$\times Tc \times C$. And consequently $P = \pi t \sqrt{\frac{2}{b}} \times \frac{Aa \times Ta \times A + Bb \times Tb \times B + Cc \times Tc \times C}{Aa \times A + Bb \times B + Cc \times C}$.

2. If the bodies are not all in one plane, let N be the center of gravity of the bodies A, B, C. And thro' N draw the plane TNR; and from all the bodies, let fall perpendiculars upon that plane. Then the periodic time will be the same as if all the bodies were placed in these points where the perpendiculars cut the plane. For if m be one of the bodies, and mC perp. to the plane. Then the centripetal and centrifugal forces of m in direction

cm , will be $cm \times bm$ and $\frac{2\pi\pi t t \times Tc}{PP}$ $m \times mc$. But

the force cm is divided into the two forces cC , Cm . And all the forces Cm destroy one another, because the plane, TNc , passes thro' their center of gravity. Therefore the plane is only acted on by
the

the remaining force cC . So that the centripetal Fig. and centrifugal forces will be the same as before, 5. when the body was placed in C; and the periodic time is the same.

Cor. 1. If Nn be drawn from the center of gravity perp. to TF ; then the periodic time of the system,

$$P = \pi t \sqrt{\frac{2}{b}} \times$$

$$\frac{Ta \times Aa \times A + Tb \times Bb \times B + Tc \times Cc \times C}{Nn \times A + B + C} \dots$$

For (Mechan. Prop. XXXV.) $Aa \times A + Bb \times B + Cc \times C = Nn \times A + B + C$.

Cor. 2. The length of a simple pendulum, making two vibrations, or an exceeding small conical motion, in the same periodic time, will be

$$\frac{Ta \times Aa \times A + Tb \times Bb \times B + Tc \times Cc \times C}{Nn \times A + B + C}$$

For let TO be the height of the cone described by the pendulum; then (Prop. IX.) $PP = \frac{2\pi\pi tt}{b} \times$

$$TO; \text{ therefore } TO = \frac{Ta \times Aa \times A + Tb \times Bb \times B + Tc \times Cc \times C}{Nn \times A + B + C} \dots$$

Cor. 3. If TO be the length of an isocronal pendulum, then O is the center of gravity of all the peripheries described by A, B, C ; each multiplied by the body; whether A, B, C be the places of the bodies, or the points of projection upon the plane TNR .

For if $Aa \times A, Bb \times B, Cc \times C$ be taken for bodies, their center of gravity will be distant from T , the length

$$\frac{Ta \times Aa \times A + Tb \times Bb \times B + Tc \times Cc \times C}{Aa \times A + Bb \times B + Cc \times C} \text{ (Mechan.}$$

Fig. chan. Prop. XXXV.) which is equal to TO by
 5. Cor. 2. and the peripheries are as the radii, Aa , Bb ,
 Cc .

Cor. 4. *If any of the bodies be on the contrary side of the axis TR , or above the point of suspension T ; that distance must be negative.*

Cor. 5. *If any line or plane figure be placed in the plane TNR ; then the point O , which gives the length of the pendulum, will be the center of gravity, of the surface or solid, described in its revolution.*

SCHOLIUM.

The point O which gives the length of the isochronal pendulum; is called the *center of turbinasion* or revolution. And the plane TNR passing thro' the center of gravity, the *turbinating plane*.

S E C T. II.

The motion of bodies in all sorts of
CURVE LINES.

P R O P. XI.

THE areas, which a revolving body describes by Fig. 6.
radii drawn to a fixed center of force, are propor-
tional to the times of description; and are all in the
same immoveable plane.

Let S be the center of force; and let the time be divided into very small equal parts. In the first part of time let the body describe the line AB; then if nothing hindered, it would describe BK = AB, in the second part of time; and then the area ASB = BSK. But in the point B let the centripetal force act by a single but strong impulse, and cause the body to describe the line BC. Draw KC parallel to SB, and compleat the parallelogram BKCr, then the triangle SBC = SBK, being between the same parallels; therefore SBC = SBA, and in the same plane. Also the body moving uniformly, would in another part of time describe Cm = CB; but at C, at the end of the second part of time, let it be acted on, by another impulse and carried along the line CD; draw mD parallel to CS, and D will be the place of the body after the third part of time; and the triangle SCD = SCm = SCB, and all in the same plane. After the same manner let the force act successively at D, E, F, &c. And making Dn = DC, and Eo = ED, &c. and compleating the parallelograms as
C 2 before;

Fig before; the triangle $CSm = CSD = DSn = DSE$
 6. $= ESo = ESF$, &c. and all in the same im-
 moveable plane. Therefore in equal times equal
 areas are described; and by compounding, the sum
 of all the areas is as the time of description. Now
 let the number of triangles be increased, and their
 breadth diminished ad infinitum; and the centri-
 petal force will act continually, and the figure
 ABCDEF, &c. will become a curve; and the areas
 will be proportional to the times of description.

Cor. 1. *If a body describes areas proportional to the times, about any point; it is urged towards that point by the centripetal force.*

For a body cannot describe areas proportional to the times, about two different points or centers, in the same plane.

Cor. 2. *The velocity of a body revolving in a curve, is reciprocally as the perpendicular to the tangent, in that point of the curve.*

For the area of any of these little triangles being given; the base (which represents the velocity) is reciprocally as the perpendicular.

7. Cor. 3. *The angular velocity at the center of force, is reciprocally as the square of its distance from that center.*

For if the small triangles CSD and SBA be equal, they are described in equal times. The
 area CSD $= \frac{SC \times CQ}{2}$, and area SBA $= \frac{SB \times BP}{2}$;
 therefore $SC \times CQ = SB \times BP$. But the angle
 CSD : angle ASB :: CQ : cq :: SC × CQ : SC ×
 cq :: SB × BP : SC × cq :: area SBA : area Scq ::
 SB² : Sc² or SC².

PROP. XII.

If a body revolving in any curve VIL, be urged by a centripetal force tending towards the center S; the centripetal force in any point I of the curve will be as

$\frac{\dot{p}}{p^3 d}$; where p = perpendicular SP on the tangent at I, and d = the distance SI.

For take the point K infinitely near I, and draw the lines SI, SK; and the tangents IP, Kf; and the perpendiculars SP, Sf. Also draw Km, Kn parallel to SP, SI, and KN perp. to SI.

The triangles ISP, IKN, nKm , are similar; as also IKm , IPq . Therefore Iq or $IP : IK :: qP : Km$. And $PS : IP :: Km : mn$. And $IN : IK :: mn : nK$. And multiplying the terms of these three proportions, $IP \times PS \times IN : IK \times IP \times IK :: qP \times Km \times mn : Km \times mn \times nK$. That is, $PS \times IN : IK^2 :: qP : nK = \frac{Pq \times IK^2}{PS \times IN}$. But (Mechan.

Prop. VI.) the space nK , thro' which the body is drawn from the tangent, is as the force and square of the time; that is (Prop. XI.) as the force and square of the area ISK, or as the force $\times SI^2 \times KN^2$, or because $SI \times KN =$ twice the triangle $ISK = IK \times SP$; therefore nK is as the force $\times IK^2 \times PS^2$. Therefore the force at I is as

$$\frac{nK}{IK^2 \times PS^2} = \frac{Pq \times IK^2}{PS \times IN \times IK^2 \times PS^2} = \frac{Pq}{PS^3 \times IN} = \frac{\dot{p}}{p^3 d}$$

Cor. I. The centripetal force at I is as $\frac{nK}{SI^2 \times KN^2}$,

or as $\frac{nK}{SP^2 \times IK^2}$.

Fig. Cor. 2. Hence the radius of curvature in I, is =

$$8. \frac{SI \times IN}{Pq}.$$

For that radius = $\frac{IK^2}{Km}$ = (by the similar triangles IKm, IqP) $\frac{IK \times IP}{Pq}$ = (by the similar triangles IPS, INK) $\frac{SI \times IN}{Pq}$.

P R O P. XIII. *Prob.*

To find the law of the centripetal force, requisite to make a body move in a given curve line.

Let the distance $SI = d$, the perpendicular SP (upon the tangent at I) = p ; then from the nature of the curve, find the value of p in terms of d , and substitute it and its fluxion, in the quantity

$$\frac{\dot{p}}{p^2 d}.$$

Or find the value of $\frac{nK}{SI^2 \times KN^2}$ or $\frac{nK}{SP^2 \times IK^2}$. Any of these will give the law of centripetal force, by the last Prop.

Ex. I.

9. If a body revolves in the circumference of a circle; to find the force directed to a given point S.

Draw SI to the body at I, SP perp to the tangent PI , SG perp. to the radius CI . Then $SP = GI$; because $SGIP$ is a parallelogram. Put $SI = d$, $SP = p$, $SC = a$, $CI = r$, $CD = x$, ID being perp. to SD . Then in the obtuse angle SCI , $SI^2 = SC^2 + CI^2 + 2SCD$, or $dd = aa + rr + 2ax$; whence $x = \frac{dd - aa - rr}{2a}$. The triangles SCG and CID are similar, whence $CI (r) : CD (x)$

(x) :: SC (a) : CG = $\frac{ax}{r} = \frac{dd - aa - rr}{2r}$; and Fig. 9.

$$p = r + \frac{dd - aa - rr}{2r} = \frac{dd + rr - aa}{2r}; \text{ and}$$

$\dot{p} = \frac{d\dot{d}}{r}$. Therefore the force $\left(\frac{\dot{p}}{p^3 d}\right)$ is as $\frac{d\dot{d}}{rp^3 d} =$

$$\frac{d}{r^3} = \frac{d \times 8r^3}{r \times (dd + rr - aa)^3}; \text{ that is, the force is as}$$

$$\frac{d}{(dd + rr - aa)^3}.$$

And if $a = r$, the force is as $\frac{1}{d^3}$.

Ex. 2.

If a body revolves in an ellipsis; to find the force 10.
tending to the center C.

Let $\frac{1}{2}$ transverse CV = r, $\frac{1}{2}$ conjugate CD = c, draw CI = d, and its semiconjugate CR = b. Then by the properties of the ellipsis (Con. Sect. B. I. Prop. XXXIV.) $bb + dd = rr + cc$,

whence $b = \sqrt{rr + cc - dd}$; and (ib. Prop. XXXVII.) b or $\sqrt{rr + cc - dd} : c :: r : p =$

$$\frac{cr}{\sqrt{rr + cc - dd}}; \text{ and } \dot{p} = \frac{cr\dot{d}}{(rr + cc - dd)^{\frac{3}{2}}}. \text{ There-}$$

$$\text{fore } \frac{\dot{p}}{p^3 d} = \frac{cr\dot{d}}{(rr + cc - dd)^{\frac{3}{2}}} \times \frac{(rr + cc - dd)^{\frac{3}{2}}}{c^3 r^3 d} = \frac{d}{ccrr}.$$

Therefore the force is directly as the distance CI.

After the same manner, the force tending to the center of an hyperbola, will be found $\frac{-d}{ccrr}$, which is a centrifugal force, directly as the distance.

Ex. 3.

If a body revolves in an ellipsis, to find the law of 11.
centripetal force, tending to the focus S.

C 4

Let

Fig. 11. Let the femitransverse $OV = r$, the femiconjugate $OD = c$, draw $SI = d$; and OI , and its conjugate $OK = b$.

Then (Con. Sect. B. I. Prop. XXXV.) $2rd - dd = bb$; and (ib. Prop. XXXVI.) b or $\sqrt{2rd - dd}$:

$$c : : d : p = \frac{cd}{\sqrt{2rd - dd}}; \text{ and } \dot{p} =$$

$$\frac{cd \sqrt{2rd - dd} - cd \times 2rd - dd^{-\frac{1}{2}} \times rd - dd}{2rd - dd} =$$

$$\frac{cd \times 2rd - dd - cd \times rd - dd}{2rd - dd^{\frac{3}{2}}} = \frac{crdd}{2rd - dd^{\frac{3}{2}}}.$$

$$\text{Therefore } \frac{\dot{p}}{p^2 d} = \frac{crdd \times 2dr - dd^{\frac{3}{2}}}{c^3 d^3 \times 2dr - dd^{\frac{3}{2}}} = \frac{crd}{c^3 d^3} = \frac{r}{ccdd}.$$

Therefore the centripetal force is as $\frac{1}{dd}$, or reciprocally as the square of the distance.

Ex. 4.

12. If a body revolves in the hyperbola VI; to find the law of centripetal force, tending to the focus S.

Draw SI , and the tangent IT , and SP perp. upon it. And let the femitransverse $SO = r$, femiconjugate $= c$, $SI = d$, $SP = p$, and $b =$ femiconjugate to IO .

Then (Con. Sect. B. II. Prop. XXXI.) $2rd + dd = bb$, and $b = \sqrt{2ra + dd}$. And (ib. Prop. XXXII.) b or $\sqrt{2rd + dd} : c : : d : p =$

$$\frac{cd}{\sqrt{2rd + dd}}; \text{ whence } \dot{p} =$$

$$\frac{cd \times \sqrt{2rd + dd} - cd \times 2rd + dd^{-\frac{1}{2}} \times rd + dd}{2rd + dd}$$

$$= \frac{cd \times 2rd + dd - cd \times rd + dd}{2rd + dd^{\frac{3}{2}}} = \frac{crdd}{2rd + dd^{\frac{3}{2}}}.$$

There-

Therefore $\frac{\dot{p}}{p^3 d} = \frac{crdd \times \sqrt{2rd + dd}^{\frac{3}{2}}}{2rd + dd)^{\frac{3}{2}} d \times c^3 d^3} = \frac{crd}{c^3 d^3} = \frac{r}{c^2 d^2}$ Fig. 12.

$\frac{r}{ccdd}$. Therefore the centripetal force is as $\frac{r}{ccdd}$ or $\frac{1}{dd}$; that is, reciprocally as the square of the distance.

And in like manner the force towards the other focus F, is $\frac{-r}{ccdd}$, or as $\frac{-1}{dd}$, which is a centrifugal force reciprocally as the square of the distance.

Ex. 5.

If a body revolves in the parabola VI; to find the force tending to the focus S. 13.

Draw IS, and the tangent IT, and SP perp. to it. And put SI = d, SP = p, latus rectum = r. Then (Con. Sect. B. III. Prop. II. and Cor. 3. Prop. XII.) $pp = \frac{1}{4} rd$, and $2p\dot{p} = \frac{1}{4} r\dot{d}$; and $\dot{p} = \frac{r\dot{d}}{8p} = \frac{r\dot{d}}{4\sqrt{rd}}$. And $\frac{\dot{p}}{p^3 d} = \frac{r\dot{d}}{4\sqrt{rd} \times \frac{1}{8} rd \sqrt{rd} \times d} = \frac{8r}{4rrdd} = \frac{2}{rdd}$. Therefore the centripetal force is reciprocally as the square of the distance CI.

Hence, in all the Conic Sections, the centripetal force tending to the focus, is reciprocally as the square of the distance from the focus.

Ex. 6.

Let VI be the logarithmic spiral, to find the force tending to the center S. 14.

Draw the tangent IP, and SP perp. to it, let SI = d, SP = p; then the ratio of d to p is always

Fig. 14. ways given, suppose as m to n . Then $p = \frac{n}{m} \dot{d}$,

and $\dot{p} = \frac{n}{m} \ddot{d}$. Consequently $\frac{\dot{p}}{p^3 \dot{d}} = \frac{n \ddot{d}}{m} \times \frac{m^3}{n^3 \dot{d}^3} = \frac{mm}{nnd^3}$; and the centripetal force is as $\frac{1}{d^3}$, or reciprocally as the cube of the distance.

P R O P. XIV.

15. *The velocity of a body moving in any curve QAO, in any point A; is to the velocity of a body moving in a circle at the same distance; as \sqrt{pd} to \sqrt{dp} . Putting $d =$ distance SA, and $p =$ SP the perpendicular on the tangent at A.*

Let AR be the radius of curvature; from the point a in the curve infinitely near A, draw am , an parallel to AS, AR. Let C = velocity in the curve, c = velocity in the circle. By similar triangle SP (p) : SA (d) :: an : am :: centripetal force tending to R : centripetal force tending to S :: (Prop. V. Cor. 2.) $\frac{CC}{AR} : \frac{cc}{AS}$. But (Prop.

XII. Cor. 2.) $AR = \frac{d\dot{d}}{p}$; whence $p : d :: \frac{CC\dot{p}}{d\dot{d}} :$

$\frac{cc}{d} :: CC\dot{p} : ccd$. And $pd : dp :: CC : cc$.

Cor. 1. *If $r =$ half the transverse axis of an ellipsis; then the velocity of a body revolving round the focus, is to that in a circle at the same distance; as $\sqrt{2r-d} : \sqrt{r}$.*

For $\dot{p} = \frac{cr\dot{d}}{2rd - d\dot{d}}^{\frac{1}{2}}$ (See Ex. 3. Prop. XIII.),

and

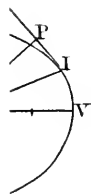
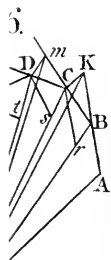

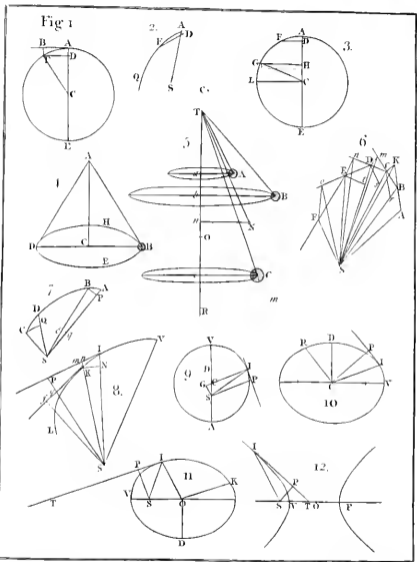

and $p = \frac{cd}{\sqrt{2rd - dd}}$. And the squares of the velocities in the curve, and in the circle, are as $\frac{cdd}{\sqrt{2rd - dd}}$ and $\frac{crdd}{(2rd - dd)^{\frac{3}{2}}}$, or as 1 and $\frac{rd}{2rd - dd}$, or as $2r - d$ to r .

Cor. 2. Suppose as before, the velocity of a body revolving round the center of an ellipsis, is to the velocity in a circle at the same distance; as half the conjugate diameter to that distance, is to the distance.

For $p = \frac{cr}{\sqrt{rr + cc - dd}}$, and $\dot{p} = \frac{crdd}{(rr + cc - dd)^{\frac{3}{2}}}$. Whence, the squares of these velocities are as $\frac{crd}{\sqrt{rr + cc - dd}}$ and $\frac{crdd}{(rr + cc - dd)^{\frac{3}{2}}}$, or as 1 to $\frac{dd}{rr + cc - dd}$, or as $rr + cc - dd$ to dd , or as bb to dd . See Ex. 2. Prop. XIII.

Cor. 3. The velocity in a parabola round the focus, is to the velocity in a circle at the same distance; as $\sqrt{2}$ to 1.

For $p = \frac{1}{2} \sqrt{rd}$, and $\dot{p} = \frac{rd}{4\sqrt{rd}}$ (See Ex. 5. Prop. XIII.) Whence the squares of these velocities are as $\frac{1}{2} d \sqrt{rd}$ and $\frac{rdd}{4\sqrt{rd}}$, or as $\frac{1}{2} rd$ to $\frac{1}{4} rd$; that is as 2 to 1.

Cor. 4. The velocity of a body in the logarithmic spiral in any point, is the same as the velocity of a body at the same distance in a circle.

For

Fig. 15. For $p = \frac{n}{m}d$, and $\dot{p} = \frac{n}{m}\dot{d}$, (Ex. 6. Prop. XIII.)

And the squares of the velocities are as $\frac{n}{m}d\dot{d}$ and $\frac{n}{m}d\dot{d}$, that is, equal.

P R O P. XV. *Prob.*

16. To find the force which acting in direction of the ordinate MP, shall cause the body to move in that curve.

Draw mp parallel and infinitely near MP, and M_s parallel to AP. Then the force is as the space mr , thro' which it is drawn from the tangent, in a given time. But ms is the fluxion and mr the second fluxion of the ordinate PM. Therefore making the fluxion of the time constant; or which is the same thing, making the fluxion of the axis constant; find the second fluxion of the ordinate, which will be as the force.

Ex. 1.

Let the curve be an ellipsis whose equation is $y = \frac{c}{r}\sqrt{2rx - xx}$. Putting $AP = x$, $PM = y$, $r =$ femitransverse, $c =$ femiconjugate. Then $\dot{y} =$

$$\frac{c}{r} \times \frac{r\dot{x} - x\dot{x}}{\sqrt{2rx - xx}}, \text{ and } \ddot{y} = \frac{c}{r} \times \frac{-\dot{x}\sqrt{2rx - xx}}{2rx - xx}$$

$$= \frac{c}{r} \times \frac{r - x}{r - x} \times \frac{r\dot{x} - x\dot{x}}{\sqrt{2rx - xx}} \times \frac{2rx - xx}{2rx - xx}^{-\frac{1}{2}} = \frac{c}{r} \times$$

$$\frac{-2rx + xx - r - x^2}{2rx - xx}^{\frac{1}{2}} = \frac{c}{r} \times \frac{-rr}{2rx - xx}^{\frac{3}{2}} = \frac{-cr}{y^3}$$

That is, the force is as $\frac{-1}{y^3}$, or reciprocally as the cube

cube of the ordinate. The same is true of the circle, which is one sort of ellipsis. Fig. 16.

Ex. 2.

Let the curve be a parabola, $AP = x$, $PM = y$, and $rx = yy$; then $r\dot{x} = 2y\dot{y}$, and $2y\ddot{y} + 2y\dot{y} = 0$; therefore $y\ddot{y} = -\dot{y}\dot{y}$, and $\ddot{y} = -\frac{\dot{y}\dot{y}}{y} = -\frac{rr\dot{x}\dot{x}}{4yy \times y} = \frac{-rr}{4y^3}$, and the force as $\frac{-1}{y^3}$, or reciprocally as the cube of the ordinate.

P R O P. XVI.

If the law of centripetal force be reciprocally as the square of the distance. The velocities of bodies revolving in different ellipses about one common center; are directly as the square roots of the parameters, and reciprocally as the perpendiculars to the tangents at these points of their orbits.

Let d, D be the distances in two ellipses; r, c, l, p ; and R, C, L, P , the femitransverse, femiconjugate, latus rectum, and perpendicular in the two ellipses. Then the squares of the velocities in two circles whose radii are d, D , (by Prop. IV. Cor. 2.) will be as $d \times$ force in d , and $D \times$ force in D ; that is, as $\frac{d}{dd}$ and $\frac{D}{DD}$ or as $\frac{1}{d}$ and $\frac{1}{D}$:

Then (Prop. XIV. Cor. 1.),
 velocity in the ellipsis d : vel. in the circle d :: $\sqrt{2r-d} : \sqrt{r}$.
 and vel. in the circle d : vel. in the circle D :: $\sqrt{\frac{1}{d}} : \sqrt{\frac{1}{D}}$.

And (Prop. XIV. Cor. 1.)
 vel. in the circle D : vel. in the ellipsis D :: $\sqrt{R} : \sqrt{2R-D}$.
 Therefore vel. in the ellipsis d : vel. in the ellipsis D ::

Fig. D :: $\sqrt{\frac{2r-d}{d} \times R} : \sqrt{\frac{2R-D}{D} \times r} :: \sqrt{\frac{2r-d}{dr}} : \sqrt{\frac{2R-D}{DR}}$.

But (Con. Sect. B. I. Prop. 36.) $p = c \sqrt{\frac{d}{2r-d}}$,
 and $p \sqrt{\frac{2r-d}{d}} = c$, and $\sqrt{\frac{2r-d}{d}} = \frac{c}{p}$, and
 $\sqrt{\frac{2r-d}{dr}} = \frac{c}{p\sqrt{r}} = \frac{\sqrt{\frac{1}{2}l}}{p}$ (because $\frac{cc}{r} = \frac{1}{2}l$ by
 the Conic Sections.) In like manner $\sqrt{\frac{2R-D}{DR}} = \frac{\sqrt{\frac{1}{2}L}}{P}$.
 Whence, vel. in the ellipsis d : vel. in the
 ellipsis D : : $\frac{\sqrt{l}}{p} : \frac{\sqrt{L}}{P}$.

Cor. 1. Hence the velocities in the two ellipsis, are
 as $\sqrt{\frac{2r-d}{dr}}$, and $\sqrt{\frac{2R-D}{DR}}$.

Cor. 2. Also the squares of the areas described in
 the same time, are as the parameters.

For the areas are as the arches \times perpendiculars,
 or as the velocities \times perpendiculars; that is, as
 $\frac{\sqrt{l}}{p} \times p$ and $\frac{\sqrt{L}}{P} \times P$, or as \sqrt{l} and \sqrt{L} .

Cor. 3. The velocity of a body in different parts of
 its orbit is reciprocally as the perpendicular upon the
 tangent at that point; and therefore is as $\sqrt{\frac{2r-d}{d}}$.

For the parameter is given.

Cor. 4. The velocity in a conic section at its great-
 est or least distance, is to the velocity in a circle at the
 the

the same distance; as the square root of the parameter, to the square root of twice that distance. Fig.

For here $d = D = p = P$, and $L = 2D$. Therefore the velocity in the ellipsis, to the velocity in the circle; as $\frac{\sqrt{l}}{P} : \frac{\sqrt{2D}}{P} :: \sqrt{l} : \sqrt{2D}$.

Cor. 5. *The velocity in an ellipsis at its mean distance, is the same as in a circle at the same distance.*

For if d be the mean distance, then $p = c$. And if D be the radius of the circle, then $L = 2D$, and $P = D$. Whence, vel. in the ellipsis : to the vel. in the circle : : $\frac{\sqrt{l}}{c} : \frac{\sqrt{2D}}{D} :: (\text{because } cc = \frac{1}{2}lr)$

$\frac{1}{\sqrt{\frac{1}{2}r}} : \frac{1}{\sqrt{\frac{1}{2}D}} :: \sqrt{D} : \sqrt{r}$. But $D = r$, therefore the velocities are equal.

Cor. 6. *Both the real and apparent velocity round the focus F, is greatest at A, the nearest vertex; and least at B, the remote vertex.* 17.

For the real velocity is reciprocally as the perpendicular, which is least at A and greatest at B. And the apparent velocity at F is reciprocally as the square of the distance from F, which distance is least at A, and greatest at B, (Cor. 2. and 3. Prop. XI.)

Cor. 7. *The same things supposed, and PC, CK being semiconjugates; the velocity in the curve, is to the velocity towards the focus F; as CK to $\sqrt{CK^2 - CD^2}$.* 23.

For vel. in the curve : vel. towards F : : $Pp : pn :: FP : NP :: d : \sqrt{dd - pp}$. But $pp = \frac{cd}{2r - d}$, and $dd - pp = \frac{2rd - dd - cc}{2r - d} d$. Whence vel. in the curve : vel. towards F : : $d :$



Fig. 23. $\sqrt{\frac{2rd - dd - cc}{2r - d}} d :: \sqrt{2rd - dd} : \sqrt{2rd - dd - cc}$
 $:: (\text{Con. Sect. B. I. Prop. XXXV.}) CK :$
 $\sqrt{CK^2 - CD^2}.$

Cor. 8. *The ascending or descending velocity is the greatest when FP is half the latus rectum, or when FP is perp. to AB.*

For $\sqrt{2rd - dd} : \sqrt{2rd - dd - cc} :: \text{vel. in}$
 the curve $\left(\frac{\sqrt{2r - d}}{d}\right) : \text{vel. towards F} =$
 $\sqrt{\frac{2rd - dd - cc}{dd}}$, and making the square of this
 velocity a maximum, then $\frac{2rd - dd - cc}{dd} = m$, and
 $2rd - 2dd \times dd - 2dd \times \frac{2rd - dd - cc}{dd} = 0$;
 and $rd - dd - 2rd + dd + cc = 0$, and $-rd$
 $+ cc = 0$. whence $d = \frac{cc}{r} = \text{half the latus rectum.}$

Cor. 9. *If FR, the distance from the focus to the curve be $= \sqrt{CA \times CD}$; then R is the place where the angular motion about the focus F, is equal to the mean motion.*

For the area of a circle whose radius FR is $= \sqrt{CA \times CD}$ is equal to the area of the ellipsis; and if we suppose them both described in equal times; then the small equal parts at R will be described in equal times; and therefore the angular velocities at F will be equal; and both equal to the mean motion. The angular motion in the ellipsis from B to R will be slower; and from R to A swifter, than the mean motion.

PROP. XVII.

If the centripetal forces be reciprocally as the squares of the distances; the periodic times in ellipses, will be in the sesquuplicate ratio of the transverse axes AB; or the squares of the periodic times, will be as the cubes of the mean distances FD, from the common center. 17.

Put the simbols as in the last, and t , T , for the periodical times. Then by the nature of the ellipsis $cc = \frac{1}{2}lr$, and $c = \sqrt{\frac{1}{2}lr}$, and $rc = r\sqrt{\frac{1}{2}lr}$. And for the same reason $RC = R\sqrt{\frac{1}{2}LR}$. Also (Prop. XVI. Cor. 2.) the areas described in the same time are as the square roots of the parameters; and therefore the whole areas of the ellipses, are as the periodical times multiplied by the square roots of the parameters. But the whole areas are also as the rectangles of the axes; therefore the rectangles of the axes are as the periodical times multiplied by the square roots of the parameters; that is, rc or $r\sqrt{\frac{1}{2}lr} : RC$ or $R\sqrt{\frac{1}{2}LR} :: t\sqrt{l} : T\sqrt{L}$. And squaring, $\frac{1}{2}lr^3 : \frac{1}{2}LR^3 :: tt : TT$. That is, $r^3 : R^3 :: tt : TT$. And $t : T :: r^{\frac{3}{2}} : R^{\frac{3}{2}} :: \sqrt{2r^{\frac{3}{2}}} : \sqrt{2R^{\frac{3}{2}}}$.

Cor. 1. The areas of the ellipses are as the periodic times multiplied by the square roots of the parameters.

Cor. 2. The periodic time in an ellipsis, is the same as in a circle, whose diameter is equal to the transverse axis AB; or the radius equal to the mean distance FD.

Cor. 3. The quantities of matter in central attracting bodies, that have others revolving about them in ellipses; are as the cubes of the mean distances, divided by the squares of the periodical times.

Fig. For (Cor. 2.) the periodic times are the same
 17. when the mean distances are equal to the radii; and
 the rest follows from Prop. VII.

P R O P. XVIII.

18. *If the centripetal forces be directly as the distances; the periodic times of bodies moving in ellipses round the same center, will be all equal to one another.*

Let AEL be an ellipsis, AGL a circle on the same axis AL, C the center of both. Draw the tangent AD, and npF parallel to it, and Dn , Bp parallel to AC: AF being very small. Then Dn equal to Bp will be as the centripetal force; and therefore AD and AB, or An and Ap will be described in the same time, in the circle and ellipsis. Consequently the areas described in these equal times will be AnC and ApC . But these areas are to one another as nF to PF , or as GC to EC ; that is, as the area of the circle AGL to the area of the ellipsis AEL. Therefore since parts proportional to the wholes are described in equal times; the wholes will be described in equal times. And therefore the periodic times, in the circle and ellipsis, are equal.

But (Prop. V. Cor. 4.) the periodic times in all circles are equal, in this law of centripetal force; and therefore the periodic times in all ellipses are equal.

Cor. *The velocity at any point I of an ellipsis, is as the rectangle of the two axes AC, CE; divided by the perpendicular CH, upon the tangent at I.*

For the arch $I \times CH$ is as the area described in a small given part of time, and that is as the whole area (because the periodic times are equal) or as $AC \times CE$. And therefore the arch I or the velo-

city, is as $\frac{AC \times CE}{CH}$.

P R O P.

P R O P. XIX.

The densities of central attracting bodies, are reciprocally as the cubes of the parallaxes of the bodies revolving about them (as seen from these central bodies), and reciprocally as the squares of the periodic times.

For the density multiplied by the cube of the diameter, is as the quantity of matter; that is (by Prop. XVII. Cor. 3.) as the cube of the mean distance divided by the square of the periodical time of the revolving body. And therefore the density is as the cube of the distance, divided by the cube of the diameter, and by the square of the periodic time. But the diameter divided by the distance is as the angle of the parallax; therefore the density is as 1 divided by the cube of the parallax, and the square of the periodic time.

P R O P. XX.

If two bodies A, B, revolve about each other; they will both of them revolve about their center of gravity. 19.

Let C be the center of gravity of the bodies A, B, acting upon one another by any centripetal forces. And let AZ be the direction of A's motion; draw BM parallel to AZ, for the direction of B. And let AZ, BH be described in a very small part of time, so that AZ may be to BH, as AC to BC; and then C will be the center of gravity of Z and H, because the triangles ACZ and BCH are similar. Whence $AC : CB :: ZC : CH$. But as the bodies A and B attract one another, the spaces Aa and Bb they are drawn thro', will be reciprocally

Fig. as the bodies, or directly as the distances from the
 19. center of gravity; that is, $Aa : Bb :: AC : BC$.
 Compleat the parallelograms Ac and Bd ; and the
 bodies, instead of being at Z and H , will be at c
 and d . But since $AC : BC :: Aa : Bb$. By divi-
 sion $AC : BC :: aC : bC$. But $AC : BC :: AZ :$
 $BH :: ac : bd$. Whence $aC : bC :: ac : bd$. There-
 fore the triangles cCa , and dCb are similar, whence
 $Cc : Cd :: ac : bd :: AC : BC :: B : A$. There-
 fore C is still the center of gravity of the bodies
 at c and d .

In like manner, producing Bd and Ac , till dg be
 equal to Bd , and cq to Ac ; and if cf , db , be the
 spaces drawn thro' by their mutual attractions; and
 if the parallelograms ce , di , be compleated. Then
 it will be proved by the same way of reasoning, that
 C is the center of gravity of the bodies at q and g ,
 and also at e and i , where A describes the diagonals
 Ac , ce , &c. and B the diagonals Bd , di , &c. and
 so on ad infinitum.

If one of the bodies B is at rest whilst the other
 moves along the line AL . Then the center of
 gravity C will move uniformly along the line CO
 parallel to AL . Therefore if the space the bodies
 move in, be supposed to move in direction CO ,
 with the velocity of the center of gravity; then
 the center of gravity will be at rest in that space,
 and the body B will move in direction BH parallel
 to CO or AZ ; and then this case comes to the
 same as the former. Therefore the bodies will al-
 ways move round the center of gravity, which is
 either at rest, or moves uniformly in a right line.

If the bodies repel one another; by a like rea-
 soning it may be proved that they will constantly
 move round their center of gravity.

If the lines CA , Cc , Ce , &c. be equal; and
 CB , Cd , Ci , &c. also equal. Then it is the case
 of two bodies joined by a rod or a string; or of
 one

one body composed of two parts. This body or Fig. bodies will always move round their common cen- 19. ter of gravity.

Cor. 1. *The directions of the bodies in opposite points of the orbits, are always parallel to one another.*

For since $AZ : Zc :: BH : Hd$; and AZ, Zc parallel to BH, Hd ; therefore the $\angle ZAc = \angle H Bd$, and Bd parallel to Ac . And for the same reason di is parallel to ce , &c.

Cor. 2. *Two bodies, acting upon one another by any forces; describe similar figures about their common center of gravity.*

For the particles Ac, Bd of the curves are parallel to one another, and every where proportional to the distances of the bodies AC, BC .

Cor. 3. *If the forces be directly as the distances; the bodies will describe concentrical ellipses round the center of gravity.*

Cor. 4. *If the forces be reciprocally as the squares of the distances; the bodies will describe similar ellipses or some conic sections, about each other, whose center of gravity is in the focus of both.*

P R O P XXI.

If two bodies S, P attract each other with any forces, and at the same time revolve about their center of gravity C. Then if either body P, with the same force, describes a similar curve about the other body S at rest; its periodical time, will be to the periodical time of either about the center of gravity; as the square root of the sum of the bodies ($\sqrt{S + P}$), to the square root of the fixed or central body (\sqrt{S}). 20.

Let PV be the orbit described about C , and Pv that described about S . Draw the tangent Pr , take

Fig. the arch PQ extremely small, and draw CQR; also draw Sqr parallel to CR, and then PQ and Pq will be similar parts of the curves PV and Pv.

Now the times that the bodies are drawn from the tangent thro' the spaces QR, qr, with the same force, will be as the square roots of the spaces QR, qr; that is (because of the similar figures CPRQ and SPrq) as \sqrt{CP} to \sqrt{SP} ; that is, (by the nature of the center of gravity) as \sqrt{S} to $\sqrt{S + P}$. But the times wherein the bodies are drawn from the tangent thro' RQ, rq, are the times wherein the similar arches PQ, Pq are described; and these times are as the whole periodic times. Therefore the periodic time in PV, is to the periodic time in Pv; as \sqrt{S} to $\sqrt{S + P}$.

Cor. 1. *The velocity in the orbit PV about C, is to the velocity in the orbit Pv about S; as \sqrt{S} to $\sqrt{S + P}$.*

For the velocities are as the spaces divided by the times; therefore, vel. in PV : vel. in Pv :: $\frac{PQ}{\sqrt{S}}$: $\frac{Pq}{\sqrt{S + P}}$:: $\frac{CP}{\sqrt{S}}$: $\frac{SP}{\sqrt{S + P}}$:: $\frac{S}{\sqrt{S}}$: $\frac{S + P}{\sqrt{S + P}}$:: \sqrt{S} : $\sqrt{S + P}$.

Cor. 2. *Bodies revolving round their common center of gravity, describe areas proportional to the times.*

P R O P. XXII.

20. *If the forces be reciprocally as the squares of the distances; and if a body revolves about the center L in the same periodical time, that the bodies S, P, revolve about the center of gravity C. Then will SP : LP :: $\sqrt[3]{S + P}$: $\sqrt[3]{S}$.*

Let PN be the orbit described about L. Then (Prop. XXI.) per. time in PQ : per. time in Pq :: \sqrt{S} :

$\sqrt{S} : \sqrt{S + P} :: \sqrt{CP} : \sqrt{SP}$. And (Prop. XVII.) Fig.
 per. time in Pq : per. time in PN :: $SP^{\frac{3}{2}} : LP^{\frac{3}{2}}$; 20.
 supposing PQ, PN , similar arches. Therefore
 per. time in PQ : per. time in PN :: $\sqrt{CP} \times SP^{\frac{3}{2}} :$
 $\sqrt{SP} \times LP^{\frac{3}{2}} :: \sqrt{CP \times SP^2} : \sqrt{LP^3}$. But the periodic
 times are equal ; therefore $\sqrt{CP \times SP^2} = \sqrt{LP^3}$,
 and $LP^3 = CP \times SP^2$, and $LP = \sqrt[3]{CP \times SP^2}$.
 But $LP : SP :: \sqrt[3]{CP \times SP^2} : SP$ or $\sqrt[3]{SP^3} : :$
 $\sqrt[3]{CP} : \sqrt[3]{SP} :: \sqrt[3]{S} : \sqrt[3]{S + P}$.

Cor. 1. *If the forces be reciprocally as the squares of the distances ; the transverse axis of the ellipsis described by P about the center of gravity C, is to the transverse axis described by P about the other body S at rest, in the same periodical time ; as the cube root of the sum of the bodies S + P, to the cube root of the fixed or central body S.*

Cor. 2. *If two bodies attracting each other move about their center of gravity. Their motions will be the same as if they did not attract one another, but were both attracted with the same forces, by another body placed in the center of gravity.*

P R O P. XXIII. *Prob.*

Suppose the centripetal force to be directly as the distance. To determine the orbit which a body will describe, that is projected from a given place P, with a given velocity, in a given direction PT. 21.

By Ex. 2. Prop. XIII. the body will move in an ellipsis, whose center is C the center of force ; and the line of direction PT will be a tangent at the point P. Draw CR perp. to PT . And let the distance $CP = d$. $CR = p$, semitransverse axis
D 4 CA

Fig. 21. CA = R, femiconjugate axis CB = C. CG (the femiconjugate to CP) = B. f = space a body would descend at P, in a second, by the centripetal force. v = the velocity at P, the body is projected with, or the space it describes in a second. Then $\sqrt{2df}$ = velocity of a body revolving in a circle at the distance CP.

Then (Prop. XIV. Cor. 2.) $v : \sqrt{2df} :: B : d$, and $B\sqrt{2df} = dv$, and $2BBdf = ddvv$, whence $BB = \frac{dvv}{2f}$, and $B = v\sqrt{\frac{d}{2f}}$. But (Con. Sect. B. I. Prop. XXXIV.) $RR + CC = BB + dd = \frac{vvd}{2f} + dd$. And (ib. Prop. XXXVII.) $CR = Bp$

$= pv\sqrt{\frac{d}{2f}}$. Therefore $RR + CC + 2RC = \frac{vvd}{2f} + dd + 2pv\sqrt{\frac{d}{2f}}$, and $R + C =$

$\sqrt{\frac{vvd}{2f} + dd + 2pv\sqrt{\frac{d}{2f}}} = m$. Also $RR + CC$

$- 2RC = \frac{vvd}{2f} + dd - 2pv\sqrt{\frac{d}{2f}}$, and $R - C =$

$\sqrt{\frac{vvd}{2f} + dd - 2pv\sqrt{\frac{d}{2f}}} = n$. Therefore $R =$

$\frac{m + n}{2}$, and $C = \frac{m - n}{2}$.

Then to find the position of the transverse axis AD. Let F, S be the foci. Then (by Con. Sect. B. I. Prop. II. Cor.) we shall have SC or CF = $\sqrt{RR - CC}$. Put FP = x ; then SP = $2R - x$, and (ib. Prop. XXXV.) $SP \times PF$ or $2Rx - xx = BB$, and $RR - 2Rx + xx = RR - BB$, and $R - x = \pm \sqrt{RR - BB}$; whence $x = R \pm \sqrt{RR - BB}$; that is, the greater part FP = $R +$

Sect. II. CENTRIPETAL FORCES.

41

$\sqrt{RR - BB}$, and the lesser part $SP = R - \sqrt{RR - BB}$. Then in the triangle PCF or PCS, all the sides are given, to find the angle PCF or PCA. Fig. 21.

Cor. *The periodical time in seconds, is* $3.1416 \sqrt{\frac{2d}{f}}$.

For arch $\sqrt{2df}$: time 1" :: circumference $3.1416 \times 2d$: $3.1416 \sqrt{\frac{2d}{f}}$ the periodical time in a circle whose radius is d . And by Prop. XVIII. the periodical time is the same in all circles and ellipses.

P R O P. XXIV. *Prob.*

Supposing the centripetal force reciprocally as the square of the distance; to determine the orbit which a body will describe; that is, projected from a given place P, with a given velocity, in a given direction PT. 22.

By Prop. XIII. the body will move in a conic section, whose focus is S the center of force. And the line of direction PT will be a tangent at the point P. Let the distance $SP = d$, transverse axis $AD = z$. $f =$ space a body will descend at P, in a second, by the centripetal force. $v =$ the velocity the body is projected with from P, or the space it describes in a second. Then $\sqrt{2df}$ is the velocity of a body revolving in a circle, at the distance SP.

Then (Prop XIV. Cor. 1.) $v : \sqrt{2df} :: \sqrt{z - d} : \sqrt{\frac{1}{2}z}$. Whence $v\sqrt{\frac{1}{2}z} = \sqrt{2dfz - 2ddf}$, and $vvz = 4dfz - 4ddf$; and $4dfz - vvz = 4ddf$, whence $z = \frac{4ddf}{4df - vv} = AD$. And $PH = z - d = \frac{dvv}{4df - vv}$. Therefore if $4df$ is greater than vv ,

vv ,

Fig. *vv*, *z* is affirmative, and the orbit is an ellipse.
 22. But if lesser, *z* is negative, and the curve is a hyperbola, and if equal, 'tis a parabola.

Draw *SR* perp. to *PT*, and let *SR* = *p*. Also draw from the other focus *H*, *HF* perp. to *PT*. Then (Con. Sect. B. I. Prop. X.) the angle *SPR* = angle *HPF*, whence the triangles *SPR*, *HPF* are similar; therefore *SP* (*d*) : *SR* (*p*) :: *HP* (*z* - *d*) : *HF* = $\frac{z-d}{d}p$; and (ib. Prop. XXI.) *SR* × *HF* or $\frac{z-d}{d}pp$ = rectangle *DHA* or *CB*², the square of half the conjugate axis; therefore *CB* = $p\sqrt{\frac{z-d}{d}}$.

In the triangle *SPH*, the angle *SPH* and the sides *SP*, *PH* are given, to find the angle *PSH*, the position of the transverse axis.

Cor. 1. *The periodical time in the ellipse APDB*
 = $3.1416 \times \frac{4ddf}{4df - vv}^{\frac{3}{2}}$.

For $3.1416\sqrt{\frac{2d}{f}}$ = periodic time in the circle whose radius is *d*. And (Prop. XVII.) $\sqrt{2d}^{\frac{3}{2}} : 3.1416\sqrt{\frac{2d}{f}} :: z^{\frac{3}{2}} : \text{period. time in the ellipse} = 3.1416\sqrt{\frac{2d}{f}} \times \left(\frac{z}{2d}\right)^{\frac{3}{2}} = 3.1416 \times \frac{4ddf}{4df - vv}^{\frac{3}{2}}$.

Cor. 2. *The latus rectum of the axis AD is* = $\frac{ppvv}{ddf}$.

Cor. 3. *Hence the transverse axis and the periodic time will remain the same, whatever be the angle of direction SPT.*

For

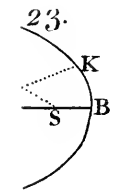
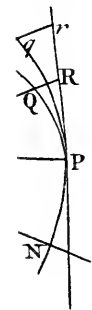
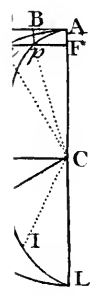
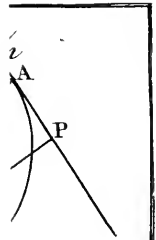
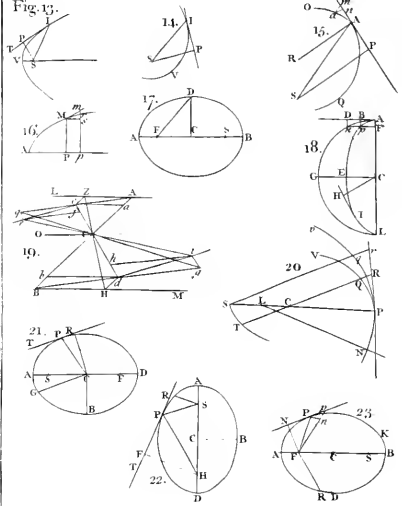

Fig. 13.



For no quantities but d , f , and v are concerned; Fig. all which are given. 22.

S C H O L I U M.

Some people have dreamed that there may be a system of a sun and planets revolving about it, within any small particle of matter; or a world in miniature. But this cannot be; for though matter is infinitely divisible; yet the law of attraction of the small particles of matter, not being as the squares of the distances reciprocally, but nearer the cubes; therefore the revolution of one particle of matter about another, cannot be performed in an ellipsis, but in some other curve; where it will continually approach to or recede from the center; and so at last will lose its motion. Such motion as these can be nothing like that of a sun and planets.

P R O P. XXV.

If a body revolves in the circumference of a circle 24- ZPA, in a resisting medium, whose density is given. To find the force at any place P, tending to the center C; as also the time, velocity, and resistance. Supposing the resistance as the square of the velocity.

Draw PC, and dp parallel and infinitely near it, cutting the tangent Pd in d . And put $CZ = r$, $ZP = z$, time of describing $ZP = t$, velocity at $P = v$, resistance = R , $f =$ force at P , $g =$ force of gravity at Z , $c =$ velocity in Z . And let a body moving uniformly with the velocity 1 , thro' the space 1 , in the time 1 , meet the resistance i in the medium. And let a body descend thro' the space a , by the force g at Z , in the same time 1 .

1. By the laws of uniform motion, the space is as the time \times velocity. Whence 1 (space) : 1×1

(time \times vel.) : : $\dot{z} : vt = \dot{z}$, whence $\dot{t} = \frac{\dot{z}}{v}$.

2. By

Fig.
24.

2. By the nature of the circle, $dp = \frac{\dot{z}^2}{2r} = \frac{vvt\ddot{t}}{2r}$.

3. By accelerated motion, the space is as the force \times square of the time; whence $g \times 1^2$ (force \times time²): a (space) :: $f\ddot{t}t$: dp or $\frac{vvt\ddot{t}}{2r}$:: $2rf$: vv
 $= \frac{2arf}{g}$. And $cc = 2ar$.

4. The velocity generated (or destroyed) is as the force \times time; therefore, $g \times 1$ (force \times time) : $2a$ (velocity) :: $R\dot{t}$: $-\dot{v} = \frac{2aR\dot{t}}{g} = \frac{2aR\dot{z}}{gv}$, and $-\dot{v} = \frac{2aR\dot{z}}{g}$.

5. The resistance is as the square of the velocity, whence 1^2 (vel.²) : 1 (resistance) :: vv : $R = vv$.

Therefore $-\dot{v} = \frac{2aR\dot{z}}{g} = \frac{2avv\dot{z}}{g}$. And $-\frac{\dot{v}}{v} = \frac{2a\dot{z}}{g}$, whence $-\log : v = \frac{2az}{g}$, and corrected, $\log : \frac{c}{v} = \frac{2az}{g}$.

Again, since $\frac{2arf}{g} = vv$, $\frac{arf}{g} = v\dot{v} = -\frac{2avv\dot{z}}{g}$, and $\dot{f} = -\frac{2v\dot{v}\dot{z}}{r} = -\frac{4arf\dot{z}}{gr}$, and $-\frac{\dot{f}}{f} = \frac{4a\dot{z}}{g}$, and $-\log : f = \frac{4az}{g}$, and corrected, $\log : \frac{g}{f} = \frac{4az}{g}$.

Also $i = \frac{\dot{z}}{v} = \frac{-g\dot{v}}{2avv}$, and $t = \frac{g}{2av}$, and corrected $t = \frac{g}{2av} - \frac{g}{2ac}$.

Cor.

Cor. 1. Hence $v =$ number belonging to the logarithm : $\log : c = \frac{2az}{g}$. And $f =$ number belonging to the logarithm : $\log : g = \frac{4az}{g}$.

Cor. 2. Therefore the logarithms of v and f , each of them severally decreases equally, in describing equal spaces, ad infinitum. And therefore at every revolution, the $\log :$ of v is equally diminished, and likewise that of f . But the body will revolve for ever, for when v is 0, t will be infinite.

Cor. 3. Hence if the central body at C , was so diminished that its $\log :$ may decrease equally in describing equal spaces, or in each revolution, after the manner as before-mentioned; then the body will perpetually revolve in a circle, in a medium of uniform density.

Fig.

S E C T. III.

The motion of three bodies acting upon one another ; the perturbuting forces of a third body. The motion of bodies round an axis at rest, or having a progressive motion, and other things of the same nature.

P R O P. XXVI.

25. *If a body be projected from A, in a given direction AD, and be attracted to two fixed centers S, T, not in the same plane with AD ; the revolving triangle SAT, drawn thro' the moving body, shall describe equal solids in equal times, about the line ST.*

Divide the time into infinitely small equal parts ; it is plain that equal right lines AB, BC, CD, &c. would be described in these equal times ; and consequently that all the solid pyramids STAB, STBC, STCD, &c. are equal, which would be described in the same equal times ; if the moving body was not acted on by the forces S and T.

But let the forces at S and T, act at the end of the several intervals of time ; as suppose the force T to act at B in direction BT ; so that the body, instead of being at C, is drawn from the line BC, in the direction CF, parallel to BT. And in like manner it is drawn from the line BC, by the force S, in direction CE parallel to SB. And therefore, by the joint forces, the body at the end of the time, must be somewhere in the plane ECF parallel to SBT,

SBT, as at I. But (Geom. VI. 17.) the solid Fig. pyramids STBI and STBC, are equal; being contained 25. between the parallel planes ECF and SBT, and therefore have equal heights; whence $STBI =$ pyramid STAB.

In like manner continue BI, making $IK = BI$; and in the next part of time, the body would arrive at K, describing the pyramid STIR equal to STBI. But being drawn from the line IK, by the forces S, T, in the directions KL, KN, parallel to IS, IT; the body will be found at the end of the time, somewhere in the plane LKN parallel to SIT, as suppose at O, and then it will have described the solid $STIO = STIK = STBI =$ pyramid STAB.

And in the same manner producing IO to P, till $OP = OI$. Then the body, attracted from O, by the forces S, T, will describe another equal pyramid. And so it will continue to describe equal pyramids in equal times; and consequently the whole solids described are proportional to the times of description.

Cor. 1. *When the number of lineolæ AB, BI, IO, &c. is increased, and their magnitude diminished, ad infinitum; the orbit ABIO, becomes a curve.*

Cor. 2. *Any line AB is a tangent at A, BI at B, &c. A, B, &c. being any points in the orbit.*

Cor. 3. *But the orbit ABIO is not contained in one plane, except in some particular cases.*

For that the orbit may not deviate from a plane; the forces on both sides thereof, ought to be alike.

Fig.

P R O P. XXVII.

26. *If the body T revolves in the orbit TH, about the body S at a great distance, whilst a lesser body P revolves about T very near; and if C be the centripetal force of S acting upon T. Then the disturbing force of S upon P is $= \frac{3PK}{ST}C$. Supposing PK parallel, and KT perp. to ST. And $\frac{PT}{ST}C =$ the increase of centripetal force from P towards T.*

Let $ST = r$, $PT = a$, $PK = y$, $g =$ force of gravity, $b =$ space descended thereby in time t . $s =$ the space descended in the time t , by the force C . $p =$ periodic time of T about S, and $t =$ per. time of P about T. $\gamma =$ centripetal force of T at P, $\pi = 3.1416$.

Since attraction is reciprocally as the square of the distance, then force of S acting at T : force of

S acting at P :: $\frac{1}{ST^2} : \frac{1}{SP^2} :: \frac{1}{rr} : \frac{1}{r-y^2} :: r :$

$r + 2y$, nearly. And force of S acting at T : to difference of the forces :: $r : 2y$; that is, $r : 2y ::$

$C : \frac{2y}{r} C =$ difference of the forces; and this is the single force by which P is drawn from the orbit QAZ in direction KP or PS.

But since the motion will be the same, whether the single force PS act in the direction PS; or the two forces PT, TS act in the directions PT, TS; substitute these two for that single one; therefore proceeding as before, the force of S acting at T :

force of S acting at P :: $\frac{1}{rr} : \frac{1}{r-y^2}$. And force

of

of S acting at P in direction PS : force of S acting on P in direction of TS :: PS : TS :: $r - y$: 26.

$r :: \frac{1}{r} : \frac{1}{r - y}$. Therefore *ex æquo*, force of S acting at T : force of S acting on P in direction TS :: $\frac{1}{r^3} : \frac{1}{r - y^3} :: \frac{1}{r^3} : \frac{1}{r^3 - 3r^2y} :: \frac{1}{r} : \frac{1}{r - 3y} :: r : r + 3y$, nearly.

And the force at T : difference of the forces :: $r : 3y$; or $r : 3y :: C : \frac{3y}{r} C =$ disturbing force of P, acting in direction parallel to TS. And PK (y) : PT (a) :: increase of the disturbing force in direction PK ($\frac{y}{r} C$) : $\frac{a}{r} C$, the addition of the centripetal force in direction PT. For when the disturbing force was $\frac{2y}{r} C$, there was no addition of centripetal force at T, but a diminution thereof; as appears by the following Corol.

Cor. 1. *The simple disturbing force, whereby P is drawn towards S, is $= \frac{2y}{r} C$. And the diminution of centripetal force of P towards T, is $= \frac{v}{r} C$. And the accelerating force at P in the arch PA, is $= \frac{z}{r} C$.*

Putting $z =$ sine of $2PQ$, $v =$ versed sine of $2PQ$.

For let $x = PK$, and draw KI perp. to PT ; then by similar triang'les, $PT (a) : PK (y) :: PK : PI ::$ force PK ($\frac{2y}{r} C$) : force in direction IP or $TP = \frac{2yv}{ar} C = \frac{v}{r} C$.

Also $PT (a) : TK (x) :: PK : KI ::$ force PK
E (2y)

Fig. 26. $\left(\frac{2y}{r}C\right)$: force in direction KI or PA $= \frac{2xy}{ar} C = \frac{z}{r}C$. By Trigon. B. I. Prop. II. Schol.

Cor. 2. *The disturbing force at P is $= \frac{q}{59^{\frac{1}{2}}}\gamma$, q being the sine of the distance from the quadrature, P the moon, S the sun.*

For (Prop. V.) $C = \frac{ttr}{ppa}\gamma$, and $\frac{3y}{r}C = \frac{3ty}{ppa}\gamma = \frac{3q\gamma}{178^{\frac{1}{2}}}$ (because $\frac{y}{a} = \frac{q}{1}$) $= \frac{q}{59^{\frac{1}{2}}}\gamma$ nearly.

Cor. 3. *If S be the sun, P a body in the equinoctial of the earth; the disturbing force at P is $= \frac{qg}{12852000}$.*

For when P is at the moon's orbit, the force is $\frac{q}{59^{\frac{1}{2}}}\gamma$; but $g = 60 \times 60\gamma$, or $\gamma = \frac{1}{3600}g$, therefore the force becomes $\frac{qg}{59^{\frac{1}{2}} \times 3600}$, and at the earth is $\frac{qg}{59^{\frac{1}{2}} \times 60^3}$.

Cor. 4. *If S be the moon, P a body on the equinoctial of the earth. The disturbing force at P is $= \frac{qg}{2880000}$.*

For the general perturbing force was $\frac{3y}{r}C$, and here C must be the centripetal force at the moon. Now the centripetal force of the earth, at the distance of the moon is $\frac{1}{60^3}g$. And the moon being 40 times less than the earth, the centripetal force of

Sec. III. CENTRIPETAL FORCES.

51

of the moon, at the same distance, is $\frac{1}{40 \times 60^2} g$; put this for C, then the force of the moon upon the equinoctial, is $\frac{3y}{r} \times \frac{g}{40 \times 60^2} = \frac{3yg}{60a \times 40 \times 60^2}$
 $= \frac{9g}{20 \times 40 \times 60^2}$.

Fig. 26.

Cor. 5. *The disturbing force of the sun, to that of the moon, upon the equinoctial; is as 1 to 4.46.*

For these forces are as $\frac{1}{12852000}$ and $\frac{1}{2880000}$
 or as 288 to 1285, or as 1 to 4.46.

Cor. 6. *If f be the apparent diameter, and d the density of the perturbing body. Then the disturbing force will always be as df^3y .*

For that force is $\frac{3y}{r} C$ or as $\frac{yC}{r}$. Let its diameter, $= b$, $M =$ its quantity of matter. Then C is as $\frac{M}{rr}$; that is, as $\frac{db^3}{rr}$. Therefore the disturbing force is as $\frac{db^3y}{r^3}$, or as $dy \times f^3$.

Cor. 7. *If P be a point in the equator of the earth, S the sun.*

The centrifugal force of P :

is to the perturbing force PT ::

As the square of the earth's periodical time about the sun pp :

to the square of the earth's periodical time about its axis tt.

Let $t =$ time of revolution of the earth round its axis; then $t : 2\pi a$ (circumference) :: $1'' : \frac{2\pi a}{t}$ = arch described in one second; and the ver-

Fig. 26. ed line $= \frac{4\pi\pi aa}{tt \times 2a} = \frac{2\pi\pi a}{tt} =$ ascent or descent by the earth's centrifugal force. But forces are as their effects, whence $b : g :: \frac{2\pi\pi a}{tt}$ (ascent) : $\frac{2\pi\pi ag}{ttb}$ the centrifugal force itself. But the perturbing force is $\frac{a}{r}C = \frac{asg}{rb}$. Whence the centrif. force : perturbing force : : $\frac{2\pi\pi ag}{ttb} : \frac{asg}{rb} :: \frac{2\pi\pi}{tt} : \frac{s}{r} :: 2\pi\pi r : tts :: \frac{2\pi\pi r}{s} : tt$. But $\frac{2\pi\pi r}{s} = pp$. For $\sqrt{2rs} : 1'' :: 2\pi r : p = \frac{2\pi r}{\sqrt{2rs}}$, and $pp = \frac{4\pi\pi rr}{2rs} = \frac{2\pi\pi r}{s}$.

Cor. 8. Hence the body P is accelerated from the quadratures Q, Z, to the siziges A, B; and retarded from the siziges to the quadratures. And moves faster, and describes a greater area, in the siziges than in the quadratures.

P R O P. XXVIII.

The same things supposed as in the last Prop. the linear error generated in P in any time, is as the disturbing force and square of the time. And the angular error, seen from T, will be as the force and square of the time directly, and the distance TP reciprocally.

For the motion generated in a given part of time, by any force, will be as that force; and in any other time as the force and the square of the time. The motion so generated is the linear error of P, as it is carried out of its proper orbit, by the force $\frac{3y}{r}C$. And that error, as seen from T, is as the angle

angle it is seen under; and therefore is as that linear Fig. error, divided by the distance TP; and therefore 26. is as the force and square of the time, divided by the distance.

Cor. 1. *The linear error generated in one revolution of P, is as the disturbing force and square of the periodical time, $\frac{3ca}{r}tt$. And the angular error in one revolution is as the force and square of the periodical time divided by the distance.*

Cor. 2. *The mean linear error of P in any given time, will be as the force and periodical time, $\frac{a}{r}Ct$. And the mean angular one, as the force and periodical time, divided by the distance.*

For let the given time be 1; then t (time) : $\frac{aC}{r}tt$ (whole error) : : 1 : $\frac{aCt}{r}$, the error in the given time.

Cor. 3. *The mean lineal error in any given time, is as TP and the periodical time of P directly, and the square of the periodical time of T reciprocally. And the mean angular error, as the periodical time of P directly, and the square of the periodical time of T reciprocally.*

For (Prop. V.) C is as $\frac{r}{pp}$, and $\frac{at}{r}C$ is as $\frac{at}{r} \times \frac{r}{pp}$ or $\frac{at}{pp}$. And the angular error as $\frac{t}{pp}$.

Cor. 4. *In any given time, the lineal error is as TP and the periodical time of P directly, and the cube of ST reciprocally. And the angular error as the periodical time of P directly, and the cube of ST reciprocally.*

Fig.
26.

For (Prop. XVII.) pp is as r^3 , therefore $\frac{at}{pp}$ is as $\frac{at}{r^3}$.

Cor. 5. *The linear error in a given time is as $\frac{a^{\frac{5}{2}}}{r}C$, and the angular error as $\frac{a^{\frac{3}{2}}}{r}C$.*

For t is as a^3 , and $\frac{at}{r}C$ as $\frac{a^{\frac{5}{2}}}{r}C$.

Cor. 6. *And universally, the angular errors in the whole revolution of any satellites; are as the squares of the periodic times of the satellites directly, and the squares of the periodic times of their primary planets reciprocally. And the mean angular errors are as the periodical times of the satellites, divided by the squares of the periodic times of their primary planets.*

For by Cor. 1. the angular error is as the force and square of the time divided by the distance; that is, as $\frac{Ca}{r} \times \frac{tt}{a}$; that is, (because C is as $\frac{r}{pp}$) as $\frac{tt}{pp}$. The rest is proved in Cor. 3.

P R O P. XXIX.

27. *If a spheroid AB revolves about an axis ST in free space, which axis is in an oblique situation to the spheroid; the spheroid will, by the centrifugal force, be moved by degrees into a right position ab; and afterwards by its libration, into the oblique position $\alpha\beta$. And then will return back into the positions ab, AB; and so vibrate for ever.*

Let C be the center of the spheroid; D the center of gravity of the end ICLB; E that of the end ICLA; Dd , Ee perp. to ST . Then the centrifugal force of the end CB , supposing it to act wholly

wholly at D, in direction dD , having nothing to oppose it, will move the end CB from B towards b , with a force which is as (d) . And at the same time, the centrifugal force of the end CA, acting in direction eE , will move the end CA from A towards a , conspiring with the motion of the end CB; by which means it will by degrees come into the position ab . And then by the motion acquired, it will come into the position $\alpha \beta$, making the angle $SC \alpha = SCB$. And the motion being then destroyed, it will return back, by the like centrifugal forces, acting the contrary way; and be brought again into the positions ab , and AB; and continue to vibrate thus perpetually.

Cor. Hence if the axis of the earth is not precisely the same as the axis of its diurnal rotation; the earth will have such a libration as is here described, but exceeding small. This is supposing it a solid body; but if it was a fluid, it would by the centrifugal force, form itself into an oblate spheroid.

P R O P. XXX. Prob.

If a globe APBQ in free space, revolve about the axis SCT, in direction ADB; and if any force applied at V, the end of the radius CV, acts by a single impulse in direction VG perp. to CV, in the plane VCD. To find the axis about which the globe shall afterwards revolve.

Suppose the great circle VBQA perp. to the line of direction VG; and if VH, VI be 90 degrees; it is plain, if the first motion was to cease; the globe by the impulse at V, would revolve round the axis IH, which by the first motion was round the axis PQ. Therefore by both motions together it will move round neither of them. Now

Fig. 28. since a point of the surface moving with the greatest velocity about ST, will move along the great circle ADB; and a point having the greatest velocity about IH, moves along the great circle VDE. Therefore a point that will have the greatest velocity, by the compound motion, will also be in a great circle passing thro' D. Therefore in the great circles DB, DE, take two very small lines Dr , Do , in the same ratio as the velocities in AD, and VD; and compleat the parallelogram $Dopr$. Then thro' D and p draw a great circle $KDpL$; and a point having the greatest motion, arising from a composition of the other two motions, will move along $KDpL$. Therefore finding F, R the poles of the circle $KDpL$, FR will be the new axis of revolution, or the axis sought. And the velocity about the axis FR will be proportional to Dp ; VBQA being always supposed perp. to GV, or to the plane DVC.

Note, if you suppose an equal force applied at E, in direction contrary to GV, it will by that means keep the center C of the globe unmoved, and will likewise generate twice the motion in the globe.

Cor. 1. *The greater the force is that is applied to V, the greater the distance PF is, to which the pole is removed. And if several impulses be made successively at V, when V is in the circle APB, the pole F will be moved further and further towards H, in the circle APB.*

For several small forces or impulses have the same effect as a single one equal to them all.

29. Cor. 2. *If the force act at P, in direction perp. to the plane CPB; and Dr , Do be as the velocities along DB and DQ. The great circle KDL . (passing thro' D and p) is the path of the point D; and its pole F; or axis of revolution RF; the pole being translated from*

from P to F. And if the impulse be exceeding small, Fig. PF will also be exceeding small. 29.

Cor. 3. If the force at P always acts in parallel directions, whilst the globe turns round. The pole will make a revolution in a small circle upon the surface of the globe, in the time of the globe's rotation, and the contrary way to the globe's motion.

For let a single impulse at P translate the pole to F; and afterwards when the globe has made half a revolution, and the point P is come to p ; then if a new impulse be made at F, the pole will be translated to p which is now P; that is, it will be moved back to its first place on the globe. So that in any two opposite points of rotation, the place of the pole is moved contrary ways, and so is carried back again the same distance. And since the globe revolves uniformly, if the force act uniformly, it will move the pole all manner of ways, or in all manner of directions upon its surface; that is, it will describe a circle, which will end where it begun. And in describing this polar circle, the motion will be contrary to the motion of the globe; for suppose PFB an immovable plane. If the globe stood still, the pole would move in a great circle, in the plane PFB. But since all the points of the globe which come successively to the plane PB, are not yet arrived at it, but are so much further short of it, as PF is greater; 'tis evident all these points will lie on this side the plane PB. And as any fixed point will describe a circle on the moving globe, contrary to the motion of the globe; so will a point that is not fixed, but moving in the plane PFB, likewise describe a circle (or some curve) contrary to the motion of the globe. Or shorter thus, suppose the globe to stand still, and the direction of the force to move backward, then the relative motion will be the same as before; and then

Fig. then the pole F will move backward too, as it will follow the force, being at right angles to it.

Cor. 4. *Since the pole by one impulse is translated to F ; the new pole F is therefore another point of the material globe, distinct from P . And the particle P that was before at rest, will now revolve about the particle F at rest.*

For the new pole F is that particle of the globe which happened to be revolving in F , when the impulse was made at P . The matter of the great circle ADB does not come into the circle KDL , but only the point D of it. For when the force is impressed, the other particles M, N , by the compound motion, will be made to revolve in the directions Mm, Nn , parallel to Dp ; and therefore will describe lesser circles about F ; whilst only D describes the great circle KDL .

Cor. 5. *What is demonstrated of a sphere is true also of an oblate spheroid, whose axis is PQ ; and the force impressed at P , acting in direction perp. to CPB , or parallel to CD the radius.*

Cor. 6. *But if the force at P act in direction contrary to the foregoing (as in case of an oblong spheroid); the pole of rotation will be moved from P towards A , contrary to the way of the other motion.*

Cor. 7. *And in general the pole P will always be moved in a direction perp. to that of the power; and towards the same way as the spheroid revolves.*

Cor. 8. *Hence after every half rotation of the globe round its axis, the places upon the globe change their latitude a little; which, after an entire rotation return to the same quantity. But this variation is so trifling, as to come under no observation.*

This is evident, because the pole is altered; and of

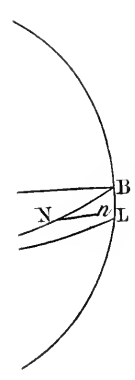
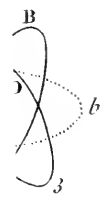
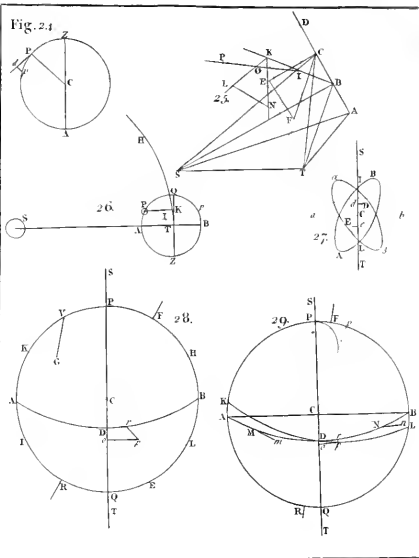

Fig. 24



of consequence, the distance therefrom is altered Fig. in all places, except in the great circle FCR. 29.

P R O P. XXXI. *Prob.*

Let AB be an oblate spheroid, whose axis is PC; 30. and let it revolve round that axis, in the order ADB, which is its equinoctial; and if any force act at P, in direction PG perp. to PC, and in the plane POC, which moves slowly about, in the order ADB. To find the motion generated in the spheroid.

Let EL be an immovable plane like the ecliptic, in which the center C of the spheroid always remains. ON another plane parallel to it. Erect CM perp. to these planes; and make the angle MCN = the angle B $\hat{=}$ C, in which the equinoctial B $\hat{=}$ cuts the ecliptic CL. Suppose the spherical surface OVN to be drawn, whose pole is M; and produce CP to cut it at R, in the circle ORN. Then PCD and RCM are in one plane, and both of them perp. to P $\hat{=}$ and P $\hat{=}$ C. Now to find the motion of the axis of the spheroid. Here OVN is the upper side of the surface.

This Prop. differs from the last in several respects. The last Prop. regards only the motion of the pole upon the surface of the globe, and that is caused by a motion which is generated in the globe itself. But in this Prop. we consider the motion of the axis CR in the fixed spherical surface OVN; which always proceeds in one direction, as long as the moving force keeps its position. In the last Prop. the motion of the globe round its axis is performed in a very short time; but here the revolution of the force, in the moving plane POC, is a long time in its period.

Now by the last Prop. Cor. 7. the force PG will always move the axis of rotation CPR in a direction

Fig. 30. tion perp. to PG. Therefore suppose the plane $P \odot C$ to revolve slowly round PC, and we shall find that in the beginning of the motion, when \odot or F is at \sphericalangle , then the plane ($P \odot C$ or) $P \sphericalangle C$ will be perp. to the plane CRM, and at that time the motion of R will be directed from R towards M. And when that plane comes to the position $PF \odot C$, the motion of R will be directed to some place between N and V. And when it is got to the tropic D, then R's motion is directed along the circumference RV; for then $P \odot C$ coincides with CRM. But when $P \odot C$ arrives at f , the motion will be directed from R to some point t without the circle. And lastly, when $P \odot C$ is at the other intersection γ , beyond B; the motion of R will be directed to m opposite to M. The result of all which is, that the pole R will describe such a curve as R1234; and then the same force begins again at \sphericalangle ; which being repeated, another similar figure 456 is described by R; and so on for more. The same force I say is repeated, for when the plane $P \odot C$ comes on the other side of the globe, the force acts the contrary way, and therefore 'tis all one as if it acted on the first side of the globe.

It must be observed, that as R moves thro' 1234, the intersection \sphericalangle gradually moves towards E. And as to the force PG, it may be supposed variable, at different positions of the plane $P \odot C$. And according to the quantity of force in the several places, different curves (1234) will be described.

Cor. 1. Hence it is evident, that the inclination of the planes ADB and ECL, is greatest when $P \odot C$ passes thro' \sphericalangle and γ . And least when it passes thro' the tropic D. And that the inclination decreases from the node \sphericalangle to the tropic D, and increases from the tropic to the node.

For

For when P \odot C is in \sphericalangle , R is farthest from M; Fig. but when it is in D, R is at 2, and its direction \sphericalangle is parallel to R₄, and then 2M is least.

Cor. 2. *After a revolution of the plane PF \odot C (in which the force always acts), the inclination comes to the very same it was at first.*

For at any two points F, f, equidistant on each side from the tropic; the force is directed contrary ways, from and to the circle RV; and therefore the motion, in the curve R₁₂₃₄, being also equal and contrary, from and towards RV, they mutually destroy one another; and therefore after a revolution, or rather half a revolution, the pole R is brought back to the circle RV, and then the angle RCM is the same it was at first.

Cor. 3. *The motion of the pole R, reckoned in the circle OVN, is always from R towards V, then thro' N, O, and R.*

For tho' the motion of R towards and from M, in the line Mm, in one revolution, is equal both ways; and so R is always brought to the circle again; yet the motion considered along the circle is always in the order RVN. Thus it goes thro' the curve 123 to 4, so that after half a revolution of P \odot C, it is advanced forward in the circle RV, the length R₄.

Cor. 4. *The motion along the circle is sometimes faster and sometimes slower. At 2 it moves fastest of all; at R and 4, it moves slowest, or rather is stationary for a moment.*

Cor. 5. *The pole R, and the nodes move the contrary way about, to what AB revolves.*

Cor. 6. *If the force PG stands still, the pole R will still move backwards as before; and that in a right*

Fig. right line, or rather, a great circle. And if PG moves
 30. backward thro' BDF A; the pole R will still go back-
 ward; but then the curve R24, will be concave to-
 wards M, like 87R, being contrary to the other
 where the force moved forward.

Cor. 7. But in an oblong spheroid, where the force
 acts in direction GP, quite contrary to the other;
 R will describe the curve R78, without the circle
 ORV; every particle of it in a contrary direction to
 these of R24. And therefore the pole R, and the
 nodes ν and \sphericalangle will move the same way about as ADB
 revolves, and contrary to what they do in an oblate
 spheroid.

For the force being directed the contrary way;
 of consequence the motion must be so too.

Cor. 8. And in an oblong spheroid, if the force GP
 move the contrary way about; yet the pole R will
 still move forward. And the curve described by R,
 will have its convexity the contrary way.

Cor. 9. Hence if the quantities and proportions of
 these forces, in different places be known; it will not
 be difficult to delineate the curve R1234, upon the
 spherical surface OVN M.

P R O P. XXXII. Prob.

31. If a planet (or the moon) move in the orbit AT E t,
 round an immovable center C, whose plane is inclined
 to the plane of the ecliptic AQ E; and a force acts
 upon it in lines perp. to GZ, and parallel to the eclip-
 tic, directed always from the plane GZ to either side.
 To find the motion of the nodes A, E; and the varia-
 tion of the orbit's inclination PAO.

Let ATZE be half the orbit raised above the
 ecliptic AQ, AE the line of the nodes; T, t,
 the

the tropics. Draw CM perp. to the ecliptic AQE , Fig. 31. and CR perp. to the orbit ATE . Round M as a pole describe a spherical surface $RVNX$; then RC will be the axis of the orbit, and MC of the ecliptic, or circle AQE . Thro' the points T, C, M , draw the plane RMC ; and thro' A, C, M , another plane cutting the circle RNF in X and H ; then RF is perp. XH , and the circle RNX parallel to GEQ . Note, RNX is the upper side of the surface.

Let the planet be at P , and let P_2 be the space it describes in any small time, and the line P_1 the space it would be drawn thro' in the same time, by the force acting from the plane MGZ . Compleat the parallelogram P_123 , and P_3 will be its direction by the compound force. Now as the line P_1 is parallel to the ecliptic, 'tis plain the point 3 will be below the plane of the orbit; and the plane CP_2 will be moved into the position CP_3 , revolving about C' ; consequently the axis RC will be moved in a direction perp. to CP . And the pole R will be moved to some point between F and H . This being duly attended to, the motion of the pole R will be known for all the places of P in the orbit $GATZ$. For about G the motion of R is directed perp. to Mn ; at A it moves perp. to MX , or in direction KM . At T it moves parallel to MH , or in the curve RV . Approaching to Z , it moves perp. from Mn . So that in the passage of the planet P ; from G to Z , thro' $GAPTZ$; the pole R of its orbit, moves thro' the curve $RI234$. But in the other half of the orbit $ZE1G$, as the force is directed the contrary way from the plane $GZMN$, the pole R will return back at 4, and describe a similar curve 45678. So that when the planet P has made one revolution, the pole of its orbit R will be found at 8. But in this position of the nodes, the point 8 will be within the spherical

Fig. rical surface RHNX, not reaching the periphery

31. RV. For the several parts of the curve being described in all directions in respect of the line nN ; the points R, 4, will be equidistant from nN , and likewise 4, 8, for the same reason.

Now suppose the force and the plane GZN_n to revolve about the axis CM in the order $GATE$. Then after it is come to such a position, that the ascending node A is as far on the other side of G , suppose at a ; then the pole R will be as far on the other side of V , suppose at r ; and being also as far from Nn , on the same side; the curves (12468) will approach VH there, by the same degrees as they receded from it at RV . And therefore the pole R will by degrees be brought to the circle again. Thus in every two correspondent points on each side V , the forces and their effects balance one another, and R will be at the same distance from the circle RVH . And therefore after half a revolution of the plane GZ to the nodes, the angle RCM , and consequently the inclination of the orbit, comes to the same as at first. And likewise as the pole R moves forward or backward in the circle RVH ; the motion of the nodes A, E , will be forward or backward.

Cor. 1. *In this position of the nodes at A and E , the inclination of the orbit ATE will be diminished every revolution of P . But on the opposite side at a , the inclination increases every revolution of P .*

For the points 4, 8, come nearer and nearer to M , and the contrary at r .

Cor. 2. *When the nodes are at A, E ; the inclination decreases; when the planet is in GT or Zt ; and increases in TZ and tG .*

For R moves to 3, whilst P moves thro' GT . At 3 it is at its nearest distance to M ; from 3 to
4 R

4 R recedes from M, whilst P moves thro' TZ. Fig. And the like on the other half of the orbit. 31.

Cor. 3. *When the planet is in GA and ZE, the nodes go forward. But in AZ and EG, they go backward.*

For whilst R passes thro' R₁, its motion is forward, viz. from R toward n, and at 1 where it moves parallel to RM, it is stationary; that is, when P is in A. Thro' 1234, R moves backward, or towards V; and then P is in AZ.

Cor. 4. *In general, the nodes are always regressive, except when P is between a node, and its nearest quadrature; and then they are progressive, wherever the nodes are situated.*

Cor. 5. *The nodes go fastest back when the planet is in T and t.*

For then R is at 3 and 7.

Cor. 6. *The inclination varies most, when P is at A and E.*

For then R is at 1 and 5.

Cor. 7. *And from the various situation of the nodes, and the place of P, it may easily be determined, when the inclination increases or decreases, in any case.*

Cor. 8. *Hence if the quantities of these forces were known, it would not be difficult to delineate the motion of the pole R, upon the spherical surface RXFH; and at any time to find the inclination, and place of the node.*

Cor. 9. *And to find the nature of the curve R₁234 described by the pole R. Supposing the force directed always to the sun; and to be as the distance of P from the plane GZ.*

Let RDB be the curve, and let the tangent tDT 32. revolve about the curve RDB, beginning at R, so

Fig. as the end T may move uniformly thro' all the
 32. points of the compass, in the same manner as P moves thro' its orbit ATZE*t*. It is plain this is one property of the curve RDT.

Now since the sun's rays fall at the same obliquity upon all parts of the plane ATQ, therefore the force to draw P in a direction parallel to these rays, being the same at equal distances from the plane GZ, and always as the distance; therefore by the resolution of motion, the distance that P is drawn perpendicularly from the plane of its orbit, will also be as that distance; and that is as the variation of the orbit's inclination. Therefore if P, instead of moving to 2 move to 3, then the force at P or PB (fig. 31.) will be as the angle 2P3: supposing the sun's distance from the node to remain the same, during one revolution of P.

34. But when the sun or the force alters its position, it will be greater or less on that account, in proportion to the sine of OL (where OL is perp. to AL), and that is as the sine of AO, the distance from the node, the angle A being given. From hence it follows that universally, the force acting on P will be always as $BP \times S.AO$; that is, as $S.GP \times S.AO$ (fig. 31.); that is, as the sine of the distance of P from the quadratures, and the sine of the distance of the sun at O from the node.

32. Now let us find the nature of the curve R1234, supposing AO to remain the same for one revolution of P. Put $RA = x$, $AD = y$, $RD = z$. Since by the generation of the curve, the angle AD*t* = arch GP, and the force is as the sine of GP or of AD*t*, and $\frac{\dot{x}}{z} = S.AD*t*$. Also it is plain, the increment of the curve at D is as that force; therefore $\frac{\dot{x}}{z}$ is as \dot{z} . And since in passing thro' the

particle of the curve \dot{z} , the line Dt is supposed to change its direction uniformly, therefore the angle of contact is given; whence \dot{z} or $\frac{\dot{x}}{\dot{z}}$ is as the radius of curvature, or as $\frac{\dot{z}\dot{y}}{\dot{x}}$; that is, $\frac{\dot{x}}{\dot{z}}$ is as $\frac{\dot{z}\dot{y}}{\dot{x}}$, or $ax\ddot{x} = \dot{z}^2\dot{y}$ (\dot{z} being given), and the fluent is $\frac{ax^2}{2} = y\dot{z}^2$, and $\dot{x} : \dot{z} :: \sqrt{y} : \sqrt{\frac{1}{2}a} ::$ as the sub-tangent : to the tangent; which is the property of the cycloid, $\frac{1}{2}a$ being = CB, the diameter of the generating circle.

Fig. 32.

Now at different distances of O from the node, the cycloid described will be greater in proportion to the sine of AO (fig. 31.); and even in the same cycloid, the latter part will be greater than the former part, as AO grows greater; all the parts of it increasing as the sine of AO increases; and the greatest cycloid will be when A is in the quadratures; and the least when in the syziges, where it is reduced to nothing.

Now at different distances of O from the node, the cycloid described will be greater in proportion to the sine of AO (fig. 31.); and even in the same cycloid, the latter part will be greater than the former part, as AO grows greater; all the parts of it increasing as the sine of AO increases; and the greatest cycloid will be when A is in the quadratures; and the least when in the syziges, where it is reduced to nothing.

SCHOLIUM.

From the foregoing solution, these observations may be made.

1. Tho' the curve R24 has been determined to be a cycloid, yet it is nearer an epicycloid. For at R it sets off nearly in a direction perp. to GZ, and during its generation (that is, whilst P performs a semirevolution) the point A moves towards G; and supposing the force at O to be fixed, the last particle of the curve at 4 would be parallel to that at R. But as O really moves forward, some number of degrees, suppose 14, and continues to do so, all the semirevolution; therefore every particle of the curve will have other directions in its description, being more curve than

F 2

before;

Fig. before; and at last the tangents at R and 4, will
 32. make an angle of 14 deg. which is the same as if an epicycloid was described on the convex side of a circle, going thro' an arch of it equal to 14 degrees.

2. Thus the curve described by R would be nearly an epicycloid, when the force at O is every where of the same quantity; yet as O moves about, the force will increase and decrease in proportion to the sine of AO; therefore, if you will suppose such an epicycloid described as above-mentioned, and moreover imagine the radius of the generating circle to swell or increase, in the same ratio as the S.AO increases; then such an epicycloid will nearly represent the curve described by R. For then every part of it will be greater or less, in proportion to the force that generates it. But enough of this. All that I shall add on this head is the solution of the two following problems, upon account of their curiosity, as depending on the foregoing principles.

P R O P. XXXIII. *Prob.*

To find the disturbing force of Jupiter or Saturn, upon the earth in its orbit; having that of the sun upon the moon given.

26. Let the matter in the sun and Jupiter be as m to
 1. E, I, L the periodic times of the earth, Jupiter and the moon. A, B, the distances of the earth and Jupiter from the sun. D the moon's distance from the earth. C, c , the centripetal forces of the sun and Jupiter.

Then (by Prop. XXVII.) the disturbing force of S upon P, is $\frac{3PK}{ST}C$ or as $\frac{PT}{ST}C$. Therefore if S be the sun, and P the moon, the disturbing force is

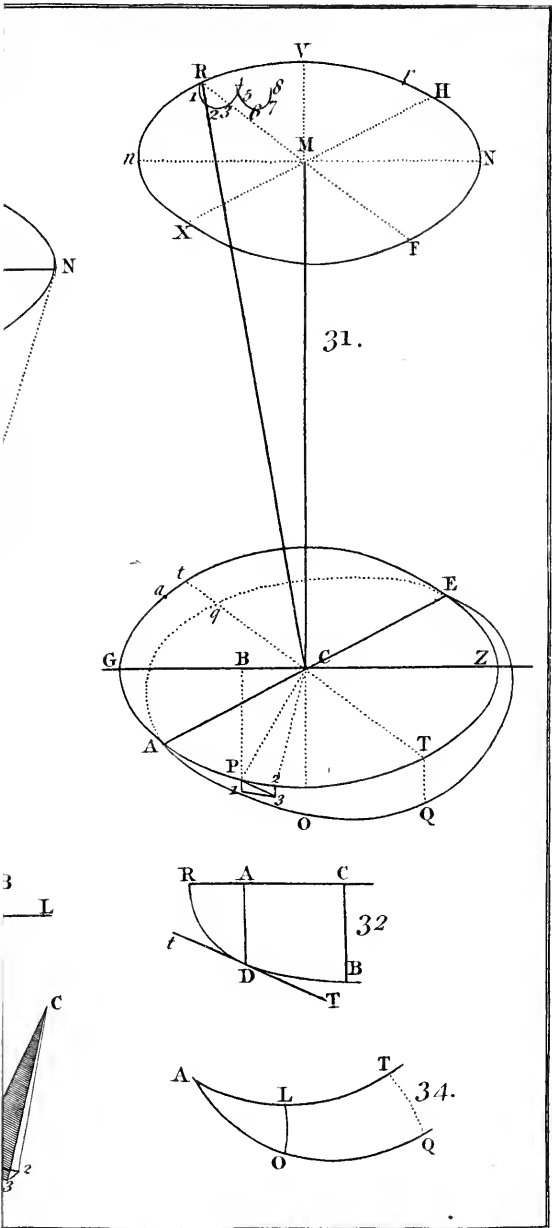

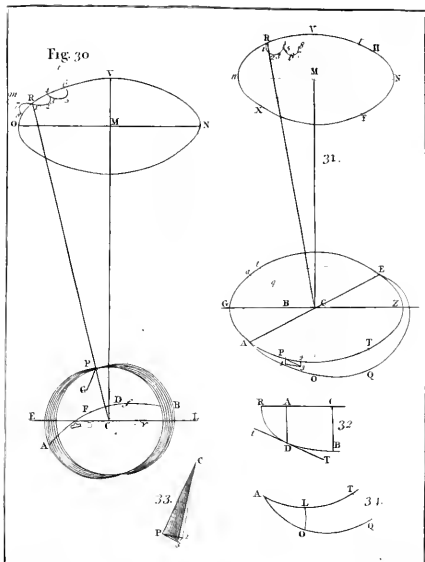

is $\frac{D}{A}C$; but if S be Jupiter, P the earth, T the

sun; then the force is $\frac{A}{B}c$. That is, the sun's disturbing force upon the moon, is to Jupiter's disturbing force upon the earth; as $\frac{D}{A}C$ to $\frac{A}{B}c$; or as

DBC to A^2c . But (Cor. 2. VII.) $C = \frac{m}{AA}$, and

$c = \frac{I}{BB}$. Therefore the sun's force upon the moon,

is to Jupiter's upon the earth; as $\frac{DBm}{AA}$ to $\frac{AA}{BB}$, or

as DB^3m to A^4 ; that is (Prop. XVII.), as DI^2m to

AE^2 . That is, the sun's disturbing force upon the moon, is to Jupiter's disturbing force upon the earth; as $D \times II \times m$, to $A \times EE$: But that of

the moon is known, and consequently that of Jupiter. And if for I and m, we put Saturn's periodic time, and quantity of matter; Saturn's disturbing force will be known.

Cor. 1. *The angular errors generated in the moon by the sun, are to the errors generated in the earth by Jupiter in the same time, :: as $III \times m$, to E^3 .*

For (Prop. XXVIII. Cor. 2.) these errors are as the forces and periodic times, divided by the distances. Therefore the sun's effect to Jupiter's, is as

$$\frac{D \times II \times m \times L}{D} \text{ to } \frac{A \times E^2 \times E}{A}; \text{ or as } III_m \text{ to } E^3.$$

Cor. 2. *Hence the error generated in the moon by the sun, is to the error generated in the earth by Jupiter; as 11230 to 1, and to that generated by Saturn, as 196076 to 1.*

For put $I = 4332 \frac{1}{2}$ days, $L = 27 \frac{1}{3}$, $m = 1067$,

$$E = 365 \frac{1}{4}; \text{ then } \frac{I^2 L m}{E^3} = 11230, \text{ And putting}$$

$$F = 3$$

$$I =$$

Fig. I = 10759 $\frac{1}{4}$, and $m = 3021$, for Saturn; then

$$26. \frac{I^2 L^m}{E^3} = 196076.$$

Cor. 3. *The force of Saturn to the force of Jupiter to disturb the earth, is as 1 to 17 $\frac{1}{2}$.*

Cor. 4. *The motion of the nodes of the earth's orbit by Jupiter's action, in 100 years, is 10' 20" $\frac{1}{2}$. And by Saturn's, 35" $\frac{2}{3}$.*

For the motion of the moon's nodes in a year is 19° 20' 32", or 69632"; this divided by 11230 gives 6".2005, multiplied by 100, is 620".05, which increased in the ratio of the cosine of inclination of Jupiter's orbit (1° 19' 10"), to that of the moon's (5° 8' $\frac{1}{2}$), produces 10' 22" $\frac{1}{2}$. Which diminished in the ratio of 1 to 17 $\frac{1}{2}$, gives 35" $\frac{2}{3}$ for Saturn.

Cor. 5. *The motion of the earth's aphelion by the action of Jupiter, is 21' 44" in 100 years, in consequentia. And by Saturn, 1' 14" $\frac{1}{2}$.*

For the motion of the moon's apogee is 40° 40' 43", or 146443" in a year. This divided by 11230 gives 13.04"; which multiplied by 100, gives 1304" or 21' 44". And divided by 17 $\frac{1}{2}$, gives 74" $\frac{1}{2}$.

P R O P. XXXIV. *Prob.*

35. *To find the variation of inclination of the earth's orbit, by the action of Jupiter in 100 years; and the like for Saturn.*

Let Υ 69 \approx Ψ be the ecliptic, or plane of the earth's orbit; GFH the orbit of Jupiter; G Jupiter's ascending node; E, I, Q, the poles of the ecliptic, Jupiter's orbit, and the equator, respectively; ECK a circle parallel to GF; and DmQ a circle parallel to the ecliptic. The pole Q here moves regularly along the circle Q/D, by the precession

cession of the equinoxes; which circle is no way affected or altered by Jupiter's action; because Jupiter cannot be supposed to have any force to move the equinoctial points, or alter their regular motion. But he has a power of acting upon the whole body of the earth, and altering its orbit, and consequently the pole E of the ecliptic; which pole is therefore made to move along the circle ECK. Therefore we must suppose the orbit of Jupiter fixed, and consequently the pole I, and circle ECK. And now we have to compute the motion of E along the circle ECK.

Fig. 35.

The precession of the equinoxes in

100 years is — — $1^{\circ} 23' 20''$

And (by the last prob.) the motion of

Jupiter's nodes in 100 years is $10' 22''\frac{1}{2}$ or $622''\frac{1}{2}$

Jupiter's ascending node G (1755,

angle QEG) — — $69^{\circ} 8' 20''$

Inclination of Jupiter's orbit — $1^{\circ} 19' 10''$.

Therefore make the angle $QEa = 1^{\circ} 23''\frac{1}{2}$, and $EIC = 10' 22''\frac{1}{2}$. Upon Ea let fall the perp. Co ; then Eo is the decrease of EQ or Ea , which (Prop. XXXII.) is the same as the decrease of the inclination of the planes of the ecliptic and equinoctial.

In the triangle EIC , by reason of the very small angle EIC , we shall have as $\text{rad} : S.IC (1^{\circ} 19' 10'')$

$$: : \text{angle } EIC (622''\frac{1}{2}) : EC = \frac{EIC \times S.IC}{\text{rad}} =$$

$14''.3$. To the angle $GEQ (8^{\circ} 20')$, add $QEa (1^{\circ} 23''\frac{1}{2})$, then aEG or $aEC = 9^{\circ} 43''\frac{1}{2}$. Then in the very small right lined triangle ECa , $\text{rad} : EC ::$

$$\text{cof. } aEC (9^{\circ} 43''\frac{1}{2}) : Eo = \frac{EC \times \text{cof. } aEC}{\text{rad}} = 14''.1.$$

$$\text{Or } Eo = \frac{EIC \times S.IC \times \text{cof. } aEC}{\text{rad}^2}, \text{ the decrease of}$$

inclination of the equinoctial in 100 years by the action.

Fig. action of Jupiter. And this decrease will amount
35. to a minute in 425 years.

If the same computation was applied to Saturn, putting $EIC = 35'' \frac{2}{3}$, $IC = 2^\circ 30' 10''$, $\angle EC = (21^\circ 21' 36'' + 1^\circ 23' \frac{1}{3}) 22^\circ 44' 56''$; the decrease by Saturn will be $1''.44$. Therefore the decrease by both will be $15''.54$; which will be a minute in 386 years.

Cor. 1. *The inclination will decrease till E and a be at their nearest distance in the two circles, which will be above 6000 years; and then it will increase again. It has likewise been decreasing for above 8000 years.*

For the diameters of the circles EK and DQ, being about as 1 to 17. And the angle IEQ being $81^\circ 40'$, and the difference of the motions of E and Q being $1^\circ 13'$; it will decrease nearly as many centuries as is the quotient of $81^\circ 40'$ divided by $1^\circ 13'$, which is 67. Also the supplement $98^\circ 20'$ divided by $1^\circ 13'$, gives 81 centuries, it has been decreasing.

Cor. 2. *But the increase or decrease for every century is not $15''.54$, as determined in this particular situation. For as it approaches to its maximum or minimum, it varies very slow, and at these places is at a stand for a long time.*

Cor. 3. *The inclination can never be less than $20^\circ 50' 54''$; nor greater than $26^\circ 7' 20''$.*

For the nearest and greatest distances of the two circles EK, DQ amount but to these. And there must be many revolutions, before they can light upon these two points, if the world can be supposed to exist so long.

SCHOLIUM.

The disturbing forces of Jupiter and Saturn here made use of are derived from that of the sun upon
on

on the moon; but these forces are really more than Fig. are here determined. For in calculating the dis- 35. turbing force of the sun (by Prop. XXVII.), the forces upon T and p are as rr to $rr + 2ry + yy$; but by reason of the great distance of the sun, the part yy is left out, as being extremely small. But in the case of Jupiter and Saturn it is otherwise, and therefore yy must be taken in. Whence the disturbing force must have an additional increase, which is as $2ry$ to yy , or as $2r$ to y , which in Jupiter is as 10 to 1, and in Saturn as 19 to 1. Therefore Jupiter's disturbing force must be increased by $\frac{1}{10}$ th, and Saturn's by $\frac{1}{19}$ th; which being done, their effects will be proportional, and the decrease of inclination of the ecliptic in 100 years, by Jupiter and Saturn will become $15''.45$, and $1''.51$; and by both $16''.96$ or $17''$ nearly; which will amount to a minute in 353 years.

But if the observations of the antients can be depended on, the obliquity decreases faster than this. For by the observations of *Aristarchus*, *Eratosthenes*, *Hyparchus*, *Ptolemy*, and *Theon*, the obliquity was found to be $23^\circ 51'$. And none of them lived 300 years before Christ, and two of them after. So that in little more than 2000 years, there is a difference of $22'$; which is more than a minute in 100 years, and is more than three times as fast as we have here determined it.

I shall now proceed to some things of another kind, relating to centripetal forces; which as far as I can find, have not been meddled with by any body before.

P R O P. XXXV. *Prob.*

If the circle GDFE be moved along the right line AB, whilst it turns round its axis; to find its motion upon a horizontal plane. 36.

Suppose the circle inclined in any given angle to the horizon, the line of direction AB being at first
in

Fig. 36. in its plane; and let it move round its axis CP , which is perpendicular to its plane, with any velocity. Let O be the center of oscillation.

Now the circle will endeavour to descend by its gravity, in the same manner, as the single point O would do. Therefore suppose the point F to descend thro' Ff in a moment of time, and that F is transferred to I in the same time. Then if the parallelogram $FfnI$ be compleated, the point F by the compound motion, will move along Fn . By this means CP , the axis of revolution, will be transferred to the position Cq , inclining more towards B . But when the circle has made half a revolution, and G is come to the place F ; the points in F , proceeding in the tract Fn , will move the axis Cq forwards, as before; that is (by the turning of the circle) it will throw it into its former place CP . So that during a revolution, the axis is thrown contrary ways in all the opposite points, and so is always restored back to its first place in regard to the plane. Therefore the circle always revolves about the axis CP , whilst CP continually inclines more and more forward; that is, the plane of the circle continually alters its position; and the variation of its position is known from the lines FI , nI ; and is equal to the angle nFI or PCq . And since the circle endeavours to move along a line which is in the plane nFG , it will no longer go along AB , but deviate from it into a new tract, which is now to be found.

It may be convenient to imagine the circle to be a polygon with an infinite number of sides. Then let KL be the horizon, Mg the plane of the circle, g being a point in the right line AB ; let the next point of the circle (or angle of the polygon) descend to the horizon, thro' the very small space rt ; then in the right angled triangle trg , S . inclination (tgr) : tr or nl (which is as S . nFI) ::
rad

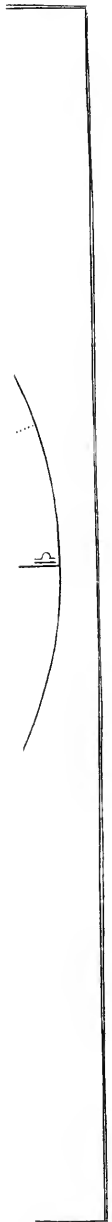
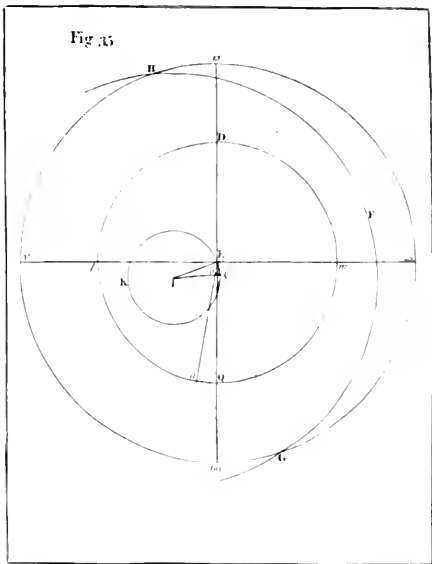

Fig 35



rad (r) : $tg = \frac{S.nFI}{S.tgr}$. Therefore if the circle be moved thro' Gg in the fame time, then from g (in the line AB) fetting off $gt = \frac{S.nFI}{S.inclination}$, then t will be a point in the curve GtR, thro' which the circle will pafs. After the fame manner it will again deviate from the laft direction tb; and describe the curve GRVWX.

Generally the whirling motion round its axis, is equal to its progrefive motion; for the friction of the plane foon reduces it to that. But take away the friction, and thefe two different motions may be what you will.

Cor. 1. *The curvature in any place, is reciprocally as thefe three quantities, the velocity of rotation, the progrefive velocity, and the tangent of inclination.*

For the curvature is as the angle tGg, that is, as $\frac{tg}{Gg}$ or as $\frac{S.nFI}{Gg \times S.inclination}$; that is, as $\frac{nI}{FI \times Gg \times S.inclin.}$; that is, as $\frac{Cof. incl.}{FI \times Gg \times S.inclin.}$ or as $\frac{1}{FI \times Gg \times \tan. inclin.}$. For nI is as the co-fine of inclination, being the fpace described upon the inclined plane nI.

Cor. 2. *Taking away all impediments, the circle always keeps the fame inclination to the horizon.*

For the pofition of the plane FnI is fuch, that the axes CP, Cq, are both parallel to it. If we fuppofe gravity to act by a fingle impulfe at O, then F will move to n, and P to q. And the plane of the circle endeavouring to defcend a little at D, and rife at F; a new point of the circle as t, lying beyond G will inflantly touch the plane; by which means it leaves the line AG. And fince at every

Fig. every point of contact as G , the pole P moves (at
36. each impulse of gravity) in a line perp. to CG ,
and also parallel to the tangent arch at G ; and the
like at every new point of contact; it is plain CP
is always alike inclined to the horizon. Conse-
quently, when gravity is continual, the circle
coming continually to new points of contact, the
axis CP will always revolve round at the same in-
clination, and therefore the plane of the circle will
also have the same inclination to the horizon.

This might also be proved after the manner of
the XXXth Prop. not considering the progressive
motion of the circle.

All this is supposing there is no resistance, fric-
tion, or other irregularity: But since in fact, the
resistance of the air continually lessens its motion,
and the smoothness of the plane it runs on, causes
the foot or bottom of the circle to slide outward,
which continually lessens the inclination, and brings
the axis more upright; and the more oblique the
plane of the circle is, the faster it slides out. Up-
on these accounts it can never describe a circle,
but only a sort of spiral line; and the plane of the
circle descending lower and lower, at last falls flat
upon the horizon.

Cor. 3. *Hence a circle moving without any resis-
tance, &c. upon a horizontal plane; will describe a
circle upon that plane.*

For the velocity and inclination continuing the
same; the curvature of the tract described, will be
every where alike.

Cor. 4. *And to find the diameter of the circle or
orbit described.*

Let t be a very small part of time wherein Gg is
described, v the velocity of projection per second,
 b the space descended by gravity in time t , s and c
the sine and cosine of the circles inclination, $f =$

16 $\frac{1}{2}$ feet; then will cb = space descended along the inclined plane Ff ; and by the laws of motion, Fig. 36.

$$i'' : v :: t'' : Gg = tv.$$

$$\text{and } tt : b :: i'' : f = \frac{b}{tt}.$$

Then whilst O has moved thro' the length Gg , t or I has descended thro' the space cb on an inclined plane parallel to Ff . But we proved $gt = \frac{nl}{s} =$

$$\frac{tr}{s} = \frac{cb}{s}. \text{ And therefore the diameter of the orbit} \\ = \frac{\overline{Gg}^2}{tg} = \frac{\overline{Gg}^2 \times s}{cb} = \frac{ttvvs}{cb} = \frac{vvs}{cf} = \frac{vv}{f} \times \tan. \text{ inclination.}$$

Cor. 5. Also to find the periodic time, or time of one revolution.

Let D = diameter of the orbit, then by Cor. last, $\frac{\overline{Gg}^2 \times s}{cb} = D$, and $Gg = \sqrt{\frac{cbD}{s}}$. The cir-

cumference of the orbit is $\frac{\pi \times \overline{Gg}^2 \times s}{cb}$ (putting $\pi = 3.1416$); and by uniform motion, $Gg : t :: \frac{\pi \times \overline{Gg}^2 \times s}{cb} : \frac{\pi ts \times Gg}{cb}$ the periodic time = $\frac{\pi ts}{cb}$

$$\sqrt{\frac{cbD}{s}} = \pi \sqrt{\frac{ttsD}{bc}} = \pi \sqrt{\frac{SD}{fc}} \therefore$$

Or thus,

$$Gg (tv) : t :: \text{circumference } \frac{\pi vvs}{fc} : \text{periodic time} \\ = \frac{\pi vs}{fc} = \frac{\pi v}{f} \times \tan. \text{ inclination.}$$

Fig.

PROP. XXXVI. *Prob.*

37. If DEF be the surface of a right cone, whose axis AE is perpendicular to the horizon, and DHFG a circular plane parallel to the horizon; and if a circle *ab* revolves round in the periphery DHFG, with its axis *tBe* always parallel to the side of the cone DE, where it then is. To find the periodic time of *ab*, in the circle DHFG.

Draw DBA perp. to DE, and BC perp. to AC. Let $\pi = 3.1416$, $b =$ space descended by gravity in the time t .

Then if the force of gravity be represented by AC, the centrifugal force at B to keep the circle *ab* in that position, thro' its whole revolution, will be denoted by BC. Then it will be AC (the gravity) : BC (the cent. force) :: $b : \frac{BC}{AC} b =$ space

descended towards C, by the force in direction BC = the effect of the centrifugal force. Therefore by (Prop. II.) the periodic time is $\pi t \sqrt{\frac{2BC}{\frac{BC}{AC} \times b}} = \pi t \sqrt{\frac{2AC}{b}}$.

$$\frac{BC}{AC} \times b = \pi t \sqrt{\frac{2AC}{b}}$$

Cor. 1. Hence the periodic time = $\pi t \sqrt{\frac{2BC}{b} \times \tan. \text{inclination } ABC}$.

$$\sqrt{\frac{2BC}{b} \times \tan. \text{inclination } ABC}$$

For S.A : S.B :: BC : AC = $\frac{S.B}{S.A} \times BC = \frac{S.B}{\cos. B} \times BC = \tan. B \times BC$; whence, the periodic time

$$= \pi t \sqrt{\frac{2BC}{b} \times \tan. ABC}$$

Cor. 2. Draw BI parallel to DE, and DL parallel to BC; then the periodic time = $\frac{\pi t \times BC \times \sqrt{2}}{\sqrt{CI} \times b}$.

$$\text{For } AC = \frac{BC^2}{CI}$$

Cor.

Cor. 3. Hence the curve described on the conic surface, is the same as that described on a horizontal plane, as explained in the last Prop. All the difference is, that the conic surface hinders the circle *ab* from sliding outward, which the horizontal plane cannot do; except it be supposed to be so rough, that the circle cannot slide on it. Fig. 37.

For in Cor. 4. of the last Prop. *v* is put for the velocity of *G* along *AB*; but putting it for the velocity at *C*, you'll have the diameter of the orbit passing thro' *C*: that is, (fig. 37.) instead of *2DL* we should find *2BC* for the diameter *D* of the orbit. 36. 37.

And by Cor. 5, the periodic time is $\pi t \sqrt{\frac{sD}{bc}}$. And in Cor. 1. of this Prop. the periodic time is $\pi t \sqrt{\frac{2BC}{b}} \times \tan. \text{inclination}$; which is equal to the former, because $D = 2BC$, and $\frac{s}{c} = \tan. \text{of the inclination}$. So the curve is the same in both cases.

P R O P. XXXVII. *Prob.*

To explain the motion of a top, or such like whirling body 38.

Let *ABC* be a top whirling about in the order *AEC*; *FDG* a circle described by any point *D* in the surface, *K* its center of gravity, *BK* the axis of the top.

If the top be upright upon the foot *B*; that is, if *BS* be perp. to the horizon, and moves swiftly about; it will continue upright till the motion slacken. But when it is going to fall, it will lean to one side; therefore suppose *D* to be the lowest point in the circle *FG*; then the top endeavours by its gravity to descend towards *D*. Let the force of gravity alone move the point *D* thro' the space *Do*, in a very small time; during which, the rotary motion

Fig. 38. motion would carry the point D to r . Compleat the parallelogram $Drpo$, and the point D will be carried thro' Dp ; that is, the circle FDG will come into the position Dp ; and therefore the axis BKS (perp. to the circle $F'G$) will be moved in a direction towards H , perp. to DK ; and the point S moved to n ; the particle Sn being parallel to Dp . After the same manner by a new impulse of gravity at p , the lowest point; the circle FDG , will be moved into a new position, below Dp , and the point S carried from n to t . And so by every impulse of gravity, the point S will be moved gradually forward, thro' the circle $Sntqlz$; and thus the top recovers itself from falling; the motion of S being always parallel to that of D . And therefore the motion of the axis BS will be the same way about, as the top's motion is. And thus the point S will continue to make several revolutions by a slow motion, whilst the top makes its revolutions about its axis, by a swift motion.

Cor. 1. *This motion of the top and its axis, is similar to the motion of an oblong spheroid, and its nodes.*

For (Cor. 6. Prop. XXX.) the nodes move the same way about as the body revolves, and so does the axis of the top; and therefore this motion may be called the motion of the nodes of the top.

Cor. 2. *When the top's motion is very swift, the circle Sq is very small; and as it grows slower, that circle will grow bigger and bigger, till the top falls.*

For when the top's motion is very swift, Dr will be greater, and the angle rDp less; and the circle Dp will deviate less from DG . And gravity having little power to disturb its motion, the circle Sq will be extremely small, and the top will revolve about the axis in appearance unmoved. But as the
top's

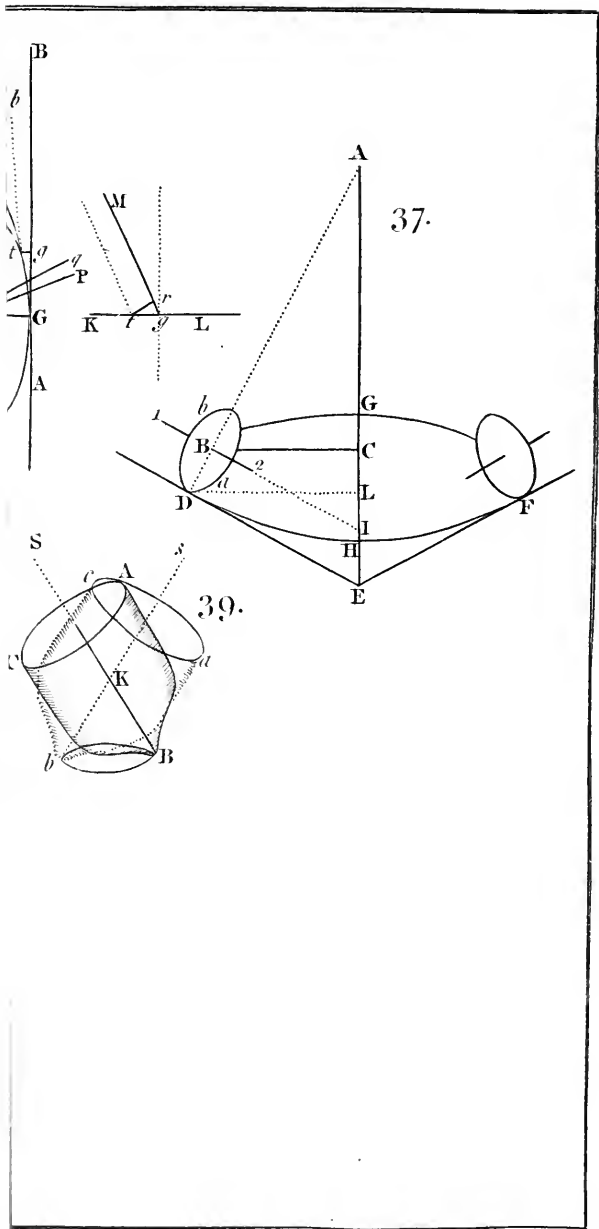

37.

39.

Fig. 36.

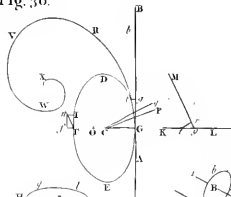

37.

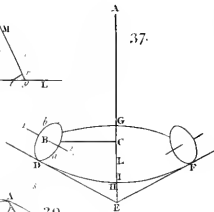

38.

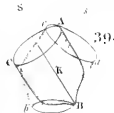
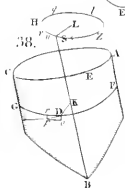

39.

top's motion by resistance and friction grows less and less, Dr will be less; and the circle Dp will deviate more from DG ; that is, gravity will have more and more power to disturb its motion; and the axis BS will describe a greater and greater circle with the point S , or rather a spiral, till at last the top falls down. Fig. 38.

Cor. 3. *As the top grows slow, and the motion weak, and the pole S describes greater and greater circles, the foot B is thrown out to the opposite side, describing a circle Bb , which is greater as Sq^l is greater; and goes the same way about.* 39.

For the center of gravity K always endeavours to be at rest, whilst the body revolves about. Therefore when the top grows weak, and the pole S describes greater circles, the foot B is thrown further out to the opposite side; and being always opposite, will describe a circle proportional to Sq^l ; the foot B going the same way about as S does. And these circles Bb will continually grow greater and greater till the top falls down. Till then the top rolls about and about from the position CAB to the opposite position cab , till the motion end, and the top falls down. And these are the principal phenomena of the motion of a top.

F I N I S.

E R R A T A.

Page	Line	read
1	11	(Preface) irregularities only
59	19	$P \hat{=} C$ and $P \hat{=} C$.
65	1	4, R recedes from M,
78	6	its axis $\perp Bz$

In the Plates.

Fig. 5. m should be shaded.

Fig. 23. Pu should be perp. to Fz .

BOOKS Printed for J. NOURSE, opposite Catharine Street, in the Strand.

1. **T**HE Elements of Trigonometry, by W. Emerson. The second Edition, with large Additions; together with the Tables of Sines, Logarithms, &c. 8vo. 1764.
2. The Elements of Geometry, by W. Emerson, 8vo. 1763.
3. A Treatise of Arithmetic, by W. Emerson, 8vo. 1763.
4. A Treatise of Algebra, by W. Emerson, 8vo. 1764.
5. Emerson's Navigation. The second Edition, 12mo. 1764.
6. A New Method of Increments, by W. Emerson, 8vo. 1763.
7. The Arithmetic of Infinites and Conic Sections, by W. Emerson, 8vo. 1767.
8. A Treatise of Algebra, by T. Simpson. The third Edition, 8vo. 1766.
9. Essays on several curious and useful Subjects in speculative and mixed Mathematics, by T. Simpson, 4to. 1740.
10. Mathematical Dissertations on a Variety of physical and analytical Subjects, by T. Simpson, 4to. 1743,
11. Miscellaneous Tracts on some curious and very interesting Subjects, by T. Simpson, 4to. 1757.
12. Trigonometry, Plane and Spherical, with the Construction and Application of Logarithms, by T. Simpson. The second Edition, 8vo. 1765.
13. The Doctrine of Annuities and Reversions, by T. Simpson, 8vo. 1742.
14. Appendix to Ditto, 8vo.
15. The Elements of Geometry, by T. Simpson. The third Edition, with large Alterations and Additions, 8vo. 1769.
16. Select Exercises for young Proficients in the Mathematics, by T. Simpson, 8vo. 1752.

17. The

17. The Doctrine and Application of Fluxions, by T. Simpson, 2 Vols. 8vo. 1750.
18. The Elements of Euclid, by R. Simpson, with the Book of Euclid's Data. To this third Edition are also added, the Elements of plane and spherical Trigonometry.
19. Introduction a l'Arithmetique Vulgaire, 4to. 1751.
20. The Elements of Navigation, by J. Robertson. The second Edition, 2 Vols. 8vo. 1764.
21. The Elements of Astronomy, translated from the French of Monf. de la Caille, by J. Robertson, 8vo. 1750.
22. The Military Engineer; or a Treatise on the Attack and Defence of all kinds of fortified Places. In two Parts, 8vo. 1759.
23. The Accomptant; or the method of Book-keeping, by J. Dodson, 4to. 1750.
24. The Mathematical Repository, by J. Dodson, 3 Vols. 12mo. 1748,—1755.
25. An easy Introduction to the Theory and Practice of Mechanics, by S. Clark, 4to. 1764.
26. The British Gauger; or, Trader and Officers Instructor in the Royal Revenue of Excise and Customs. Part. I. Containing the necessary Rules of vulgar and decimal Arithmetic, and the whole Art of Practical Gauging, both by Pen and Rule; illustrated by a great Variety of curious and useful Examples. Part. II. Containing an historical and succinct Account of all the Laws relating to the Excise: To which are added, Tables of the old and new Duties, Drawbacks, &c. on Beer, Ale, Spirits, Soap, Candles, &c. with a large and copious Index, by S. Clark, 12mo. 1765.
27. The Elements of Fortification, by J. Muller. The second Edition, 8vo. 1756.
28. The Method of Fluxions and infinite Series, with its Application to the Geometry of curve Lines, by the Inventor Sir Isaac Newton. Translated from the Author's original Latin. To which is subjoined, a perpetual Comment upon the whole Work, by J. Colson, F. R. S. 4to. 1736.

3 for 0x

University of California
SOUTHERN REGIONAL LIBRARY FACILITY
405 Hilgard Avenue, Los Angeles, CA 90024-1388
Return this material to the library
from which it was borrowed.

U. S. ...
...





3 1158 01056 3772

UC SOUTHERN REGIONAL LIBRARY FACILITY



A 000 086 423 1

