

S 4 - C b

TRANSACTIONS

OF THE
ROYAL SOCIETY OF EDINBURGH.

VOL. VI.



EDINBURGH,

PRINTED FOR CADELL AND DAVIES,
LONDON,

AND

ARCHIBALD CONSTABLE & CO. AND BELL & BRADFUTE,
EDINBURGH.

1812

TRANSACTIONS

ROYAL SOCIETY OF LONDON

VOL. VI



PRINTED BY

JOHN JOHNSON, ST. PAULS CHURCH-YARD, LONDON.

1816

THE NEWBURY PRESS, AND THE NEWBURY PRESS, NEWBURY.

1816

CONTENTS

OF THE
SIXTH VOLUME.

HISTORY of the SOCIETY.

<i>Carta Nova Ereptionis Societatis Regalis Edinburgi,</i> 1808, - - - - -	Page iii
<i>Laws of the Royal Society of Edinburgh, enacted 23d</i> <i>May 1811,</i> - - - - -	ix
<i>Presents made to the Royal Society of Edinburgh since the</i> <i>Year 1809,</i> - - - - -	xv
I. <i>A Description of the Strata which oc ur in ascending</i> <i>from the Plains of Kincardineshire to the summit of</i> <i>Mount Battoc, one of the most elevated points in the</i> <i>Eastern District of the Grampian Mountains. By</i> <i>Lieutenant-Colonel Imrie.</i> - - - - -	3
II. <i>A Geometrical Investigation of some curious and inte-</i> <i>resting Properties of the Circle, &c. By James</i> <i>Glenie, Esq.</i> - - - - -	21
	III.

- III. *Account of a Series of Experiments, shewing the Effects of Compression in modifying the Action of Heat.* By Sir James Hall, Bart. - 71
- IV. *Of the Solids of Greatest Attraction, or those which, among all the Solids that have certain Properties, Attract with the greatest Force in a given Direction.* By Mr Playfair. - Page 187
- V. *An Account of a very extraordinary Effect of Rarefaction, observed at Ramsgate, by the Reverend S. Vince.* Communicated by Patrick Wilson, Esq. 245
- VI. *Some Account of the large Snake Alea-azagur, (Boa Constrictor of Linnæus), found in the Province of Tipperah.* Communicated by Mr James Russell. 249
- VII. *Chemical Analysis of a Black Sand, from the River Dee in Aberdeenshire; and of a Copper Ore, from Arthrey in Stirlingshire.* By Thomas Thomson, M. D. - 253
- VIII. *New Series for the Quadrature of the Conic Sections; and the Computation of Logarithms.* By Mr Wallace. - 269
- IX. *Remarks on a Mineral from Greenland, supposed to be Crystallised Gadolinite.* By Thomas Allan, Esq. - 345
- X. *On the Progress of Heat when communicated to Spherical Bodies from their Centres.* By Mr Playfair. - 353
- XI.

CONTENTS.

vii

- XI. *Experiments on Allanite, a new Mineral from Greenland.* By Thomas Thomson, M. D. 371
- XII. *A Chemical Analysis of Sodalite, a new Mineral from Greenland.* By Thomas Thomson, M. D. 387
- XIII. *Demonstration of the Fundamental Property of the Lever.* By David Brewster, LL. D. - 397
- XIV. *On the Rocks in the vicinity of Edinburgh.* By Thomas Allan, Esq. - - - 405

CONTENTS

XI. Experiments on Alkali, a new Mineral, &c.
Greenland. By Thomas Thomson, M.D. 271

XII. Chemical Analysis of Soda, a new Mineral,
from Greenland. By Thomas Thomson, M.D. 287

XIII. Demonstration of the fundamental property of the
Laser. By David Brewster, M.D. 307

XIV. On the flocks in the vicinity of Edinburgh. By Tho-
mas Adam, Esq. 307

HISTORY
OF THE
SOCIETY.

IN the original charter of the Royal Society, it was provided that the collections of the Society should be deposited, if belonging to Natural History, in the Museum of the University, and if to Antiquities, in the Library of the Faculty of Advocates. Much inconvenience, however, could hardly fail to result from this arrangement, especially when the researches of the Society, having, as of late, been much turned to Geology, it became an object to collect together the specimens which served to illustrate the subjects under discussion, and to have them at hand when reference should be necessary.

IN a Museum arranged with a view to public lectures, (like that of the University), such an order as was required for this purpose could not easily be preserved; the Professor of Natural History must feel himself interrupted by the examinations which the Members of the Royal Society might wish

to make ; and it would often be a point of delicacy, not to give him the trouble that such examinations would require.

THESE considerations induced the Society to apply for a new charter, under which its collections should remain in its own possession, so as to be at all times accessible to its Members.

As the interest of the two bodies just mentioned, might be somewhat affected by these alterations, the first step taken was to give them information of the intentions of the Society, and to request their concurrence in a measure of such manifest justice and utility. The Faculty of Advocates readily assented to this proposal ; and the University, though at first in doubt whether it were not bound in duty to resist the alteration, on more mature deliberation, resolved to withdraw all opposition.

As it was not meant that the new charter should have any retrospect, the Huttonian Collection, with a great number of other articles, the property of the Society, still remain in the University Museum. The foundation of a new collection, in the Society's apartments, has been laid, by a cabinet presented by Mr ALLAN, containing specimens of the rocks round Edinburgh ; a collection by Colonel IMRIE, illustrating the section of the Grampians which he has given in the 5th volume of the *Transactions* of the Society ; and a collection of specimens from Sir GEORGE MACKENZIE, illustrating the Mineralogy of Iceland.

THE New Charter, which follows, hardly differs in any thing from that contained in the first volume of the *Transactions* of the Society, except in what respects the two restrictions that have just been mentioned.

CARTA
NOVÆ ERECTIONIS.
SOCIETATIS REGALIS EDINBURGI,
1808.

GEORGIUS TERTIUS, DEI gratia, Britanniarum Rex, Fidei Defensor; omnibus probis hominibus ad quos præsentem litteram nostram pervenerint, salutem: Quandoquidem Nos considerantes, quod petitio humilis nobis oblata fuerit a Regali Societate Edinburgi, et præfidei nostro et prædilecto consanguineo Henrico Duce de Buccleuch, ejusdem præside, in nomine et vice Societatis, et omnium ejusdem Sociorum; in qua petitione enarratur, quod per regiam nostram cartam, datam vigesimo nono die mensis Martii anno Domini millesimo septingentesimo et octogesimo tertio, Nobis benignè placuisset constituere, erigere et incorporare quosdam ibi nominatos in corpus politicum et corporatum;

a 2

*ratum, nomine tituloque REGALIS SOCIETATIS EDINBURGI, ad promovendas literas et scientiam utilem, cum facultatibus et privilegiis ibidem concessis, et speciatim, ut potens et capax sit tenendi proprietatem realem et personalem, causasque agendi et defendendi, Præsidem et Socios eligendi, canones ordinandi, et perpetuam successionem sub tali nomine habendi: quod, virtute prædictæ cartæ, Regalis Societas Edinburgi, ita creata, substituerit, suisque officiis a prima institutione, ritè functa sit: quod cartâ prædictâ ordinatum fuerit, cunctas res antiquas, tabulas publicas, librosque manuscriptos, quos acquisiverit Societas, in Bibliotheca Facultatis Juridicæ deponi; atque universas res ad historiam naturalem pertinentes, quasque Societas acquisiverit, in Musæo Academiæ Edinensis deponi: quod, ab hac constitutione incommodum haud parvum ortum fuerit; cùm Regalis Societas, nullum jus in Bibliothecarios Facultatis Juridicæ, nec in Custodes Musæi Academiæ Edinensis, habeat, nec horas eorum ministerii regulasve admissionis ad ea repositoria præscribere possit, nec Societati licitum sit congressus suos in eorum alterutro tenere; quæ cùm ita sint, hactenus Societati non licuit suas collectiones ita disponere, ut Sociorum aliorumve studio et disquisitioni aptè subjiciantur, undè et alia dona expectanda essent: Quod prædicta Societas, causâ hæc incommoda amovendi, nostraque bona proposita in hac institutione ad effectum perducendi, sapientiæ nostræ regiæ humiliter subjiciat, ut detur Societati jus collectiones suas cujuscunque generis uno in loco deponendi, quo sibi ordine placuerit, sub custodibus a Societate eligendis ejusque potestati subjectis; itaque ut cartam, cum privilegiis idoneis humilibus nostris petitoribus concedere dignemur; ut et in hac petitione oratum sit, ut Nobis benignè placeret de novo Cartam Nostram Regiam concedere dictæ Regali Societati Edinburgi, ejusque Sociis, qua iterum darentur, jura, facultates, et privilegia, in carta regia per
quam*

quam corpus istud creatum fuerat concessa, et qua insuper provideretur, ut Societati potestas daretur collectiones suas antea memoratas in uno ædificio deponendi, eis legibus, et eis ministris, qui Societati placerent, hosque sibi subjectos haberet: Et nos certiores facti hanc petitionem justam esse rationique consentaneam, et certis conditionibus et modis, in presentibus expressis, concedi debere: Igitur, constituimus, erigimus et incorporavimus, sicuti Nos regiam nostram prerogativam, et gratiam speciali, pro Nobis nostrisque regis successoribus, per has presentes, constituimus, erigimus, et incorporamus, prædictum Henricum Ducem de Buccleuch, Sociosque dictæ Regalis Societatis, atque alios qui postea eligentur Socii, in unum corpus politicum et incorporatum, vel legalem incorporationem, nomine et titulo REGALIS SOCIETATIS EDINBURGI, ad promovendas literas et scientiam utilem, utque talis existens, et tali nomine, perpetuitatem habeat et successionem; DECLARANTES, Quod dicta Societas capax sit capere, tenere, et frui proprietate reali seu personali, et petere, causas agere, defendere et respondere, et conveniri, in jus trahi, defendi et responderi, in omnibus seu ullis nostris Curis Judicaturæ; et declarantes quod dictæ Societati fas sit, sigillo, tanquam Societatis sigillo, uti; dantes potestatem dictæ Societati, per majorem suffragiorum numerum eorum qui aderunt, eligendi Præsidem aliosque officarios pro negotiorum administratione; necnon ordinandi canones, ad quos Socii sint eligendi et res Societatis sint administrandæ, conditionibus hujus cartæ sive donationis haud incongruentes, nec legibus et praxi nostri regni Scotiæ contrarios; et declarantes, quod hujusmodi canones sanciri nequeant, nisi ritè propositi fuerint in congressu habito saltem uno mense ante illum congressum quo sancienda sint: dantes etiam potestatem Societati ordinandi et administrandi collectiones re-
rum

*rum antiquarum, tabularum publicarum, librorum manuscip-
torum, et rerum ad historiam naturalem pertinentium, quas
Societas postea acquisiverit, easque in Musæo et Bibliotheca,
tali ordine et modo ut Societati placuerit, deponendi: SALVIS
tamen conditionibus, in hac nostra carta provisus; declarantes
insuper hanc cartam nostram concessam esse sub his conditioni-
bus sequentibus, videlicet, Quod jura, facultates, et privilegia,
per præsentem in dictam Societatem collata, nullo modo detra-
hent de ullo jure dominii quod competit Academia Edinensi in
collectiones antehac depositas in Musæo Academia, virtute car-
tæ nostræ Societati Regali datæ, prædicto vigesimo nono die
mensis Martii millesimo septingentesimo et octogesimo tertio;
antedicta Societate quantum in se est astricta, omne jus, ad
collectiones antehac factas et in Musæo prædicto depositas, in
dictam Academiam transferre; et quod Historiæ Naturalis Pro-
fessori copia introitus in Musæum et Bibliothecam Societatis
Regalis detur æquè ac Sociis ipsius Societatis; et quod dictæ
Societati non sit licitum constituere Professore, prælectorem
seu Doctorem Mineralogiæ, Geologiæ, aut Historiæ Naturalis,
nec suis collectionibus uti ad talem institutionem promovendam,
nisi quæ vel nunc sit, vel posthac fuerit, in Academia Edinensi.
—IN CUJUS REI TESTIMONIUM, sigillum nostrum per Unionis
Tractatum custodiend., et in Scotia vice et loco Magni Sigilli
ejusdem utend., ordinat., præsentibus appendi mandavimus;
Apud Aulam nostram apud St James's, vigesimo septimo die
mensis Decembris anno Domini millesimo octingentesimo et octa-
vo, regniq; nostri anno quadragesimo nono.*

Per

Per signaturam manûs D. N. Regis supra script.

Written to the Seal, and registered the
thirtieth day of August 1811.

JAMES DUNDAS, *Dep^t.*

Sealed at Edinburgh, the
thirtieth of August,
One thousand eight
hundred and eleven
years.

JAMES ROBERTSON,
Sub^t. £80 Scots.

THIS charter, as well as the former, having left the Society in possession of the power of making By-laws for the regulation of its affairs, it was proposed to revise the whole of those laws, and to make such alterations as, after the experience of thirty years, might appear to be necessary.

THE Society, therefore, having at several General Meetings taken this subject into consideration, after mature deliberation,

beration, and with due attention to the clause in the charter that respects the enactment of such laws, did, at a General Meeting, on the 23d of December 1811, sanction the Laws that follow, and declare them to be the rules by which the Society is to be governed, till all, or any of them are regularly repealed.

LAWS

L A W S
OF THE
ROYAL SOCIETY OF EDINBURGH,
ENACTED 23d MAY 1811.

I.

THE ROYAL SOCIETY OF EDINBURGH shall be composed of Ordinary and Honorary Members.

II.

Every Ordinary Member, within three months after his election, shall pay as fees of admission Three Guineas, and shall further be bound to pay annually the sum of Two Guineas, into the hands of the Treasurer.

III.

Members shall be at liberty to compound for their annual subscription, each paying according to the value of an annuity on his life, determined as in the ordinary insurance on lives.

The power of raising the annual subscription shall remain with the Society.

IV.

Ordinary Members, not residing in Edinburgh, and not compounding for annual subscription, shall appoint some person residing in Edinburgh, by whom the payment of the said subscription is to be made, and shall signify the same to the Treasurer.

V.

Members failing to pay their subscriptions for three successive years, due application having been made to them by the Treasurer, shall cease to be Members of the Society, and the legal means for recovering such arrears shall be employed.

VI.

None but Ordinary Members are to bear any office in the Society, or to vote in the choice of Members or Office-bearers, nor to interfere in the patrimonial interest of the Society.

VII.

The number of Ordinary Members shall be unlimited.

VIII.

The Ordinary Members shall receive the volumes or parts of the Society's Transactions, when published, at the booksellers price, or the price at which they are sold to the trade. This regulation to continue in force for five years from the date of its enactment; and it is left to the Society then to consider, whether the volumes cannot be afforded *gratis* to the Members.

IX.

The Society having formerly admitted as Non-resident Members, gentlemen residing at such a distance from Edinburgh as to be unable regularly to attend the Meetings of the Society, with power to such Non-resident Members, when occasionally in Edinburgh, to be present at the Society Meetings, and to take a part in all their inquiries and proceedings, without being subjected to any contribution for defraying the expences of the Society; it is hereby provided, that the privileges of such Non-resident Members already elected shall remain as before; but no Ordinary Members shall be chosen in future under the title and with the privileges of Non-resident Members. The Members at present called Non-resident shall have an option of becoming Ordinary Members; if they decline this, they shall continue Non-resident as formerly.

X.

X.

The Honorary Members of the Society shall not be subject to the annual contributions. They shall be limited to Twenty-one, and shall consist of men distinguished for literature and science, not residing in Scotland.

XI.

The election of Members, whether Ordinary or Honorary, shall be by ballot; it shall require the presence of Twenty-four Members at least to make a quorum, and the election shall be determined by the majority of votes.

Election of Mem-
bers.

XII.

The election of Members shall be made at one General Meeting annually, on the fourth Monday of January.

XIII.

No person shall be proposed as an Ordinary Member, without a recommendation presented by a Member of the Society, and subscribed by Three, to the purport mentioned below *; which recommendation shall be hung up in the Rooms of the Society, at least during Three Ordinary Meetings (of the Classes) previous to the day of election.

XIV.

In order to carry on with facility and success those improvements in science and literature, which are the objects of the institution, the Society shall be divided into two Classes, the Physical and the Literary Class; the former having for its department the sciences of Mathematics, Natural Philosophy, Chemistry, Medicine, Natural History, and what relates to the improvement of Arts and Manufactures; the latter having

b 2 for

* "A. B. a gentleman well skilled in many branches of Philosophy and Polite Learning, (Mathematics, Chemistry, Natural History, &c.) being to our knowledge desirous of becoming a Member of the Royal Society of Edinburgh, we whose names are subscribed, do recommend him as deserving of that honour, and as likely to prove an useful and valuable Member."

for its department the inquiries relative to Speculative Philosophy, Antiquities, Literature and Philology.

XV.

The Classes shall meet alternately on the first and third Mondays of every month, from November to June inclusive. It shall be competent, however, to bring matters of a Physical or Literary kind, before either Class of the Society indiscriminately. To facilitate this, one Minute-book shall be kept for both Classes; the Secretaries of the respective Classes either doing the duty alternately, or according to such agreement as they may find it convenient to make.

XVI.

The Society shall from time to time make a publication of its Transactions and Proceedings. For this purpose, the Council shall select and arrange the papers which they shall deem worthy of publication in the *Transactions* of the Society, and shall superintend the printing of the same.

The Transactions shall be published in Parts or *Fasciculi*, and the expence shall be defrayed by the Society.

XVII.

Office-bearers.

There shall be elected annually for conducting the publications and regulating the private business of the Society, a Council, consisting of a President; Two Vice-Presidents; a President for each Class of the Society; Six Counsellors for each Class; one Secretary for each; a Treasurer; a General Secretary; and a Keeper of the Museum and Library.

XVIII.

The election of the Office-bearers shall be on the fourth Monday of November.

XIX.

Four Counsellors, Two from each Class, shall go out annually. They are to be taken according to the order in which they presently stand on the list of the Council.

XX.

XX.

The Treasurer shall receive and disburse the money belonging to the Society, granting the necessary receipts, and collecting the money when due.

Treasurer.

He shall keep regular accounts of all the cash received and expended, which shall be made up and balanced annually; and at the General Meeting in January, he shall present the accounts for the preceding year to be audited. At this Meeting the Treasurer shall also lay before the Society a list of all arrears due above twelve months, and the Society shall thereupon give such directions as they may find necessary for recovery thereof.

XXI.

At the General Meeting in November, a Committee of Three Members shall be chosen to audite the Treasurer's accounts, and give the necessary discharge of his intronmissions.

The report of the examination and discharge shall be laid before the Society at the General Meeting in January, and inserted in the records.

XXII.

The General Secretary shall take down minutes of the proceedings of the General Meetings of the Society and of the Council, and shall enter them in two separate books. He shall keep a list of the Donations made to the Society, and take care that an account of such Donations be published in the Transactions of the Society. He shall, as directed by the Council, and with the assistance of the other Secretaries, superintend the publications of the Society.

Secretary.

XXIII.

A Register shall be kept by the Secretary, in which copies shall be inserted of all the Papers read in the Society, or abstracts of those Papers, as the Authors shall prefer; no abstract or paper, however, to be published without the consent of the Author. It shall be understood, nevertheless, that a person choosing to read a paper, but not wishing to
put

put it into the hands of the Secretary, shall be at liberty to withdraw it, if he has beforehand signified his intention of doing so.

For the above purpose, the Secretary shall be empowered to employ a Clerk, to be paid by the Society.

XXIV.

Another register shall be kept, in which the names of the Members shall be enrolled at their admission, with the date.

XXV.

A Seal shall be prepared and used, as the Seal of the Society.

XXVI.

The Librarian shall have the custody and charge of all the Books, Manuscripts, objects of Natural History, Scientific Productions, and other articles of a similar description belonging to the Society ; he shall take an account of these when received, and keep a regular catalogue of the whole, which shall lie in the Hall, for the inspection of the Members.

XXVII.

All articles of the above description shall be open to the inspection of the Members, at the Hall of the Society, at such times, and under such regulations, as the Council from time to time shall appoint.

PRESENTS

PRESENTS made to the ROYAL SOCIETY OF EDINBURGH since the Year 1809.

- The Sixth Volume of the *Scriptores Logarithmici*.—From Mr BARON MASERES.
- Treatise on the Gout, by the late Dr HAMILTON of Lynn-Regis.—From the Author.
- Traité de Mineralogie, par M. LE COMPTE DE BOURNON, 3 vols. 4to.—From the Author.
- An Engraving, representing all the Mountains of the World, by R. Riddel, Esq; together with the History of Mountains, by Joseph Wilson, Esq; vols. 1st and 2d.—From Messrs RIDDEL and WILSON.
- Recueil de Quelques Antiquités trouvées sur les Bords de la Mer Noire, par M. LEON DE WEXEL.—From the Author.
- Nova Acta Petropolitana, tom. 14.—From the IMPERIAL ACADEMY of St Petersburg.
- Philosophical Essays, by THOMAS GORDON, Esq; 2 vols. 4to.—From the Author.
- Transactions of the Linnean Society, vol. 8th and 9th.—From the LINNEAN SOCIETY.
- Asiatic Researches, vol. 10th and 11th.—From the BENGAL SOCIETY.
- Philosophical Transactions, for 1809, 1810, 1811.—From the ROYAL SOCIETY OF LONDON.
- Memoirs of the American Academy, vols. 1st, 2d, and 3d.—From the AMERICAN ACADEMY.
- Transactions of the American Philosophical Society, vol. 6th, part 2d.—From the AMERICAN PHILOSOPHICAL SOCIETY.
- Observations on the Hydrargyria, by GEORGE ALLEY, M. D.—From the Author.
- Transactions of the Geological Society of London, vol. 1st.—From the GEOLOGICAL SOCIETY.

Travels

Travels in Iceland, by Sir George Mackenzie, Baronet. Annals of Iceland, from 1796 to 1804. Manuscript copy of the Sturlinga Saga. History of Iceland during the 18th century. A compendium of Anatomy, translated into Icelandic, from the Works of Martinet. Pope's Essay on Man, in Icelandic verse.—From Sir GEORGE MACKENZIE.

Essay on the Natural History of the Salt District in Cheshire, by Dr HOLLAND.—From the Author.

Collection of Specimens, illustrating the Mineralogy of the Country round Edinburgh.—From THOMAS ALLAN, Esq;

Collection of Specimens, illustrating the Section of the Grampians, at the beginning of this volume, with a descriptive Catalogue.—From Lieutenant-Colonel IMRIE.

Model in Relief, representing the Granite Veins at the *Windy Shoulder* in Galloway.—From Sir JAMES HALL, Baronet.

Collection of Specimens, illustrating the Mineralogy of Iceland.—From Sir GEORGE MACKENZIE, Baronet.

I. *A DESCRIPTION of the STRATA which occur in ascending from the PLAINS of KINCARDINESHIRE to the SUMMIT of MOUNT BATTOC, one of the most elevated points in the Eastern District of the GRAMPIAN MOUNTAINS. By Lieutenant-Colonel IMRIE, F. R. S. EDIN.*

[Read 5th March 1804.]

THE most mountainous parts of Scotland are situated in its western and north-west districts. From those parts of the country, several chains of mountains branch off, and continue their courses in various directions, and to various extent. The most extended of those chains is that of the Grampians. This chain takes its rise from nearly about the centre of the above alpine district, and continues its course in a direction almost due east, or perhaps a little to the south of that point, until it disappears in the German Ocean, betwixt the towns of Aberdeen and Stonehaven.

THIS chain, in its eastern district, consists of three ranges, running nearly parallel to each other; the two lateral ranges being considerably lower than the central one. To the lateral mountains are attached a range of lower hills, that slope down into undulated grounds, which skirt the adjacent plains.

THE general shape of the individual mountains composing those three ranges, is oblong, rounded, and sometimes flattish on the tops; their length is always in the direction of the chain,

chain, that is to say, from west to east: and I have observed, not unfrequently, that the western ends of those oblong mountains are more bulky than their eastern extremities, and that they slope and taper in some degree towards this quarter. Their general covering is that of a coarse gravelly soil, produced by their own decomposition; and the produce of this soil is heath. But upon some of the heights in the central range, I have found beds or layers of that species of turf called *Peat*, from fifteen to twenty feet in thickness, which repose upon the gravelly soil that there covers the native rock.

AT this eastern part of the Grampians, where I am now about to endeavour to give a description of the stratification, the mountains seldom show any considerable extent of naked rock.

IN their course to the eastward, as they approach the sea, they begin to contract in breadth, and cover much less space of country; and where they finish their course at the sea, their height will scarcely entitle them to the appellation of hills: but although they become so diminutive in height and in breadth, yet the materials of which they are formed continue the same as those which compose the ranges where they are in their greatest altitude, and their exterior characters, as to form and figure, also continue the same.

AMONG the rivers which have their source in the Grampians, that of the *North Esk* is not the first in rank as to size, nor is it the most diminutive. At a considerable distance from the plains in the interior of the mountains, a small lake called *Loch Lee* is formed, in a rocky basin, by a rivulet, and some springs and rills flowing from marshy grounds. From this lake the *North Esk* issues, not in a very considerable flow, but, being soon joined by other streams and alpine torrents, it swells to a considerable size, and continues a course from this lake almost due east, betwixt the central and south lateral ranges of the mountains, for an extent of about seven miles: it then skirts Mount-Battoc, and being

ing there impeded, in its eastern direction, by some of the hills forming the basis of that mountain, it then changes its course, almost at a right angle, and from thence flows in a due south direction. In this last direction, it opens a way for itself through the south lateral range, and enters the plains of Kincardine, and Forfar shires, where it immediately becomes the line of division of those two counties. It leaves those plains by a hollow betwixt the two low hills of Garvoke and Pert, and after a course of nearly thirty miles from its source, it joins the sea somewhat to the eastward of the town of Montrose. It is in the bed of this river that I have examined the strata of the Grampians of which I am now to give a description. The section extends about six miles, from the horizontal grit or sandstone in the plain, to the granite of Mount Battoc, which is one of the mountains in the central range, and one of the highest of the chain in that part of the country. My direction, in this examination, is about due north, piercing through, almost at right angles, the strata of the mountains, which are here nearly in a vertical position.

IN this short stretch of six miles, a great deal of matter highly interesting to geology presents itself. In it, we pass from the secondary horizontal strata of the newest formation, to the vertical, contorted, primary strata of the oldest date, and terminate with granite, the primitive rock in the conception of many geologists. Thus, it embraces a complete range of the fossil objects, which in this part of Scotland intervene between that which is deemed the oldest and what is accounted the most recent in point of formation. From the various strata standing in a position vertical, or nearly so, and the river North Esk, cutting across these strata, at right angles, the succession is uncommonly well exhibited to view, and a fair display of the structure of this country, and of the materials composing it to a great depth, is open to the attentive observer. In addition to this fine display of the succession of strata, the arrangement of them will
be

be found to offer some very curious and important facts, particularly the gradual elevation, and the final perfect vertical position of the sandstone and puddingstone, as well as the rather unusual manner in which the secondary and the older strata meet each other.

IN the series here to be described, the repeated occurrence of rocks of the *whin* and of the porphyry formation, respecting the origin of which opinions are so much divided, adds considerable interest; especially when the form and situation in which they occur, and the condition of the contiguous rocks, are taken into consideration.

IN the account which I am now about to give, I shall endeavour to lay down a fair representation of the facts as Nature presents them, unbiassed by any of the prevailing theories of cosmogony. I shall avoid every geological discussion whatever, leaving it to others to draw those conclusions, in relation to their own speculations, which they shall imagine the facts to warrant.

IN that part of the plains of Kincardineshire from which I take my departure, the native rock consists of Siliceous Grit or Sandstone, which is here divided into an immense number of beds or layers, of various thicknesses, from one inch to four feet, solid stone. In many places, gravel of various sizes is found imbedded in this grit; which gravel consists mostly of water-worn quartz, and small-grained granites. The colour of the general mass of this grit is a dark-reddish brown, and in some few places it shows narrow lines and dots of a pearl-grey colour. The component parts of this grit consist of small particles of quartz, and still more minute particles of silvery-lustred mica: these owe their cohesion in mass to a martial argillaceous cement, to which this rock also owes its colour. Those lines and dots of pearl-grey colour, generally occur in the most solid and thickest beds
of.

of the rock: they are formed of the same materials with the other parts of the stone; but into them the ferruginous staining matter has not apparently been able to penetrate, and they derive their present greyish appearance from the natural colour of its particles of quartz, which are here *per se* of a bluish-white tint. This rock, in the plain, is perfectly horizontal in its position; but upon its approach towards the undulated grounds, which here form the lowest basis of the Grampians, it begins to rise from its horizontal bed, and, gradually increasing in its acclivity *towards the mountains*, it at last arrives at a position perfectly vertical.

FOR the first quarter of a mile from where this grit begins to leave its horizontal position, the rise is very gradual; but after that distance, it becomes more rapid, and in a mile it gains its vertical position.

WHERE this grit or sandstone rock is in its most solid state, and where its position is perfectly vertical, betwixt two beds or layers of it, there occurs a bed of Whinstone forty feet broad.

THE main body of this bed of whin intersects none of the layers of grit, but stands upright betwixt two of them, to both of which it is closely joined. The river, at this place, has, in its passage, worn down this bed of whin equally with that of the adjoining grit, and a perpendicular face of it can be examined upon each side of the river, from fifty to sixty feet in height.

UPON examining the section of this bed, I found upon the east side of the river two branches, which sprung from the main body of the whin, nearly where the water of the river at present washes the base of its perpendicular surface. One of those branches springs from the right side of the trunk, and the other springs from the left side: they at first diverge from the trunk as they ascend, and where they push out laterally, they intersect the contiguous strata, and penetrate them in a zig-zag manner; but at last, in a position betwixt two of the layers of the grit, they continue

tinue their direction upwards, decreasing in their diameters as they ascend, until they finish their course near to the superficial soil which here covers the rock. The grit contiguous upon both sides to the bed of whin, is considerably harder and more compact than it is in any other part of the stratification; and that angle of the grit which lies between the body of the whin and its branches, is more indurated than the strata of the grit upon each side.

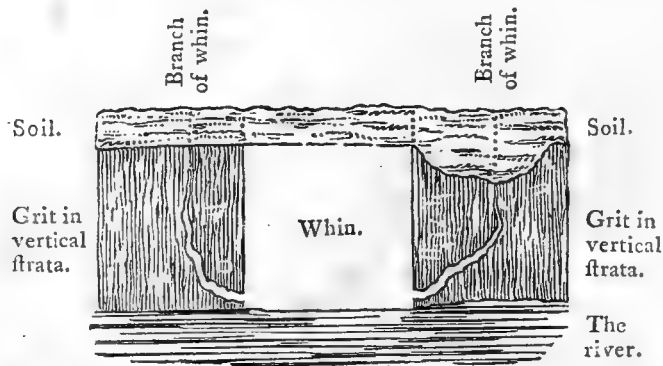

This species of whin is not very compact in its texture. Its fracture is somewhat earthy, and is of a brownish-black colour; but it has a considerable degree of induration, and has some specks of lustre in it. Having passed this bed of whin, the grit continues in the same position as immediately before the whin occurred; but, soon after, the gravel, which I have mentioned to be in some places imbedded in the grit, increases in quantity, and at last the strata are formed of a rock composed entirely of that species of gravel, and which may be called Gravel stone or Plum-pudding-rock. This aggregate constitutes a stratum four hundred yards thick. Its stretch is nearly from west to east, and it is vertical in its position. Its composition consists of quartz, porphyries, and some small-grained granites, all of which have evidently been rounded by attrition in water: they are

are of a vast variety of size, from that of a pea to the bulk of an ostrich egg. These are all firmly combined by an argillaceous ferruginous cement. In some parts of this gravel rock, are to be seen thin lines of a fine-grained grit, stretching through it from west to east; it is by those lines alone that the verticality and the stretch of this mass is discoverable. Its general colour, in mass, is that of a ferruginous red.

THIS plum-pudding rock is immediately followed by a succession of strata of fine-grained grit, in thin layers: it has a very considerable degree of induration, and is of a dark ferruginous brown colour. This deviates a little from the vertical position, and inclines to the south: the stretch is from west to east, and its extent towards the north is two hundred and sixty yards. To this rock immediately succeeds a species of Porphyry, the principal mass of which consists of an indurated argil. Its colour is of a purple or lilac brown: its induration is very considerable, and its fracture is rough and earthy. The materials which are imbedded in its mass, consist of small particles of quartz, felspar, blackish-brown mica, and specks of iron ochre; all of these are but thinly scattered. The space in the course of the river occupied by this porphyry is two hundred and twenty yards: its stretch is nearly from west to east, and it inclines in a small degree to the south. The rock which succeeds to this porphyry, and which is in contact with it, is difficult to describe; and this difficulty arises from the great disorder of the stratification, and the variety of materials composing it. The strata of this bed do not succeed each other in a regular manner. Portions of them of various dimensions lie together, but very variously disposed: some are vertical, some horizontal, some dip to the south, one only to the north, affording a solitary instance of a northern inclination of the strata in this field of examination.

THE materials of this mass of confused stratification, are of very different descriptions. In one place, a quartzose stone

abounds, of a granular texture: it here, in general, resembles a fine-grained, highly indurated, and compact quartz sandstone: sometimes, however, it approaches to hornstone, and even sometimes to quartz in mass. Much of it has a white colour: the rest is tinted of an ochery brown, of different shades. In other places, the stratified matter consists of a stone of a laminated texture, with undulating lamellæ of a ferruginous tint, looking like an indurated shale; and various gradations of both kinds present themselves. This jumble is in thickness three hundred yards; and to it immediately succeeds a very narrow stratum of Argillite, which is of a greenish-grey colour, and very thinly lamellated.

THIS argillite is succeeded by a bed of Whin, thirty-three feet broad. This whin is of a dark blackish-brown colour, and is of a more compact texture, than the whin which I have described occurring in the grit, and is possessed of more induration: the materials of composition are nearly the same in both.

Its general stretch is nearly from west to east; but in this stretch, where it has been exposed to the eye by the river, it is somewhat curved, and presents its convex side to the mountains. To this bed of whin succeeds a narrow stratum of Argillite, perfectly similar to that which I have just now described upon its southern side. To this succeeds a seam of Limestone, six feet broad. This limestone is of a pale blue colour, and is much intersected by small veins of quartz trending through it in all directions.

IN this limestone, I was unable to trace the remains of any animal or vegetable production. Its position is vertical, and it is immediately succeeded by another narrow stratum of argillite, thinly lamellated.

To this narrow stratum of argillite succeeds a bed of Whin, seventy-five feet broad. This whin is, in its texture, more compact; and its fracture displays a smoother surface than either
of

of the two former whins which I have had occasion to mention. Its colour is of a dark-bluish black. In tracing, with my eye, its vertical cracks and fissures, I thought I could perceive a rude tendency to prismatic forms. It is vertical in its position; and its stretch is from west to east.

THIS bed of whin is succeeded by an Argillite of shivery texture, and confused stratification; but as it recedes from the whin, and approaches the mountains, it becomes regularly stratified. This stratum of slate is of great extended thickness; and it contains a vast variety of colour and of tint. The colours are, pale greyish-blue, yellowish-green, reddish-brown, purple and black, with a great variety of tints of all those colours; but the predominant colours are the greyish-blue and the yellowish-green; of which two there are two sorts; the one soft, and the other much indurated. The soft is thinly laminated, and frequently passes over into the highly indurated sort, in which the appearance of the laminated texture is almost lost.

IN this long succession of argillite strata, some substances occur that are heterogeneous to its rock, such as jaspers, limestone, &c.

THE jaspers are in general of a blood-red colour, and are much veined with white quartz: they occur in large amorphous masses, and in nests, of elliptic forms, of great variety of size. One of those bodies of jasper, in the elliptic form, has been cut through by the river, and is now to be seen in the face of the perpendicular rock, upon each side of the stream. Its size is thirty feet long, by ten broad: the points of its transverse axis are sharp; and it stands upright in the argillite. The masses of this matter which occur amorphous in the argillite, are of great magnitude. I have traced one of those for thirty yards in extent. All of those jaspers are of great induration, and take a high polish. Both the amorphous and the elliptical formed masses are found imbedded, where the argillite is of a greenish-grey colour,

thinly lamellated, of a silky lustre, and saponaceous to the feel: it clings round those masses in all their variety of direction, and of course its texture is there much twisted. When the argillite stratification has extended its thickness to near three quarters of a mile, the limestone which I have mentioned above then occurs, in a bed of twelve feet thick. Its colour is bluish-black; and it is much pervaded by veins of quartz, and of calcareous spar; the last of those are, in many places, of considerable breadth, and are of a pale flesh colour. Where this limestone has been wrought, I observed it forked; that is to say, the bed is there split or divided into two, by the intervention of an argillaceous body. Upon each side of this bed of limestone the argillite occurs of two colours. That which is next to, and in contact with the limestone, is black, of a shaly texture, soils the hand, and has veins of ferruginous-coloured quartz trending through it. The argillite which is more remote from the limestone is of a dark purple colour.

IMMEDIATELY after this narrow bed of shale, the argillite re-assumes its greenish-blue colour, and slaty texture, and becomes highly indurated: here some specks of granulated quartz begin to appear, thinly scattered in its mass, and, soon after, it is seen to pass over into an aggregate rock, chiefly composed of grains of quartz, felspar, and minute particles of mica. The particles of quartz and of felspar seldom occur in this aggregate larger than the eighth of an inch: these have very little the appearance of having suffered attrition: they are much mixed, and are frequently seen to take lineal directions; and in those lines the particles of felspar have frequently a compressed appearance, and an eye-like form. This rock, in mass, has a greyish-blue colour: it is of great induration, and although lamellous or slaty in its texture, a cross fracture is often more easily obtained than one with the lamellæ. Its cross fracture is pretty even, but appears more granular than foliaceous. This rock occurs frequently in
the

the district of blue clay slate, and may almost be said to alternate with it. I have been perhaps more minute in the description of this rock than it deserved; but I have been so, because doubts have arisen relative to what name ought to be given to this aggregate. In all my geological researches, I have found this rock only twice; once, where I have here described it; and, again, near to Banff, on the Moray Frith. In both of those situations, the aggregates are of the same composition, and similar in position: they both lie among blue clay slate.

IN this long alternation, two substances occur which are heterogeneous to the rocks among which they lie. The first of those, is a bed of compact Felspar, of great induration. This bed is ten feet broad: its stretch is nearly from west to east: its position is vertical; and it stands between two of the layers of the blue clay slate. Its colour is of a reddish-brown, with a small admixture of purple; and its general fracture is conchoidal, somewhat rough, but not earthy.

NOT far distant from this bed, an appearance occurs worthy of some notice. Where the aggregate and the blue clay slate are alternating, a surface of considerable extent of the aggregate rock is exposed to view, parallel to its stratification. This surface is regularly undulated in small undulations, bearing a very strong resemblance to those that may be seen upon the sand of the sea-beach, when recently left by the tide. After passing the bed of compact felspar, the blue clay slate and aggregate rock again alternate; but here the blue clay slate predominates. Near to this, the second substance heterogeneous to those alternating rocks occurs. It is a bed of Whin, the form of which is somewhat singular. It consists of a principal trunk, which the river, here cuts nearly at right angles. Upon the east side of the river, this principal trunk is seen to split into three branches; and those three take an eastern direction, between the strata of the aggregate rock and the blue clay slate, where those two rocks are of great induration. The
breadth

breadth of this bed of whin is thirteen feet; and where it splits, its three branches are, six, four, and three feet in diameter. The trend or stretch of this bed is from west to east; but upon the west side of the river, it curves somewhat to the south-west. Its composition is nearly the same with the three other beds of whin which I have before mentioned. It is of a brownish-black colour, and, when placed in certain directions, it shows specks of lustre. It is vertical in its position, has a great degree of induration, and its general fracture is roughly conchoidal.

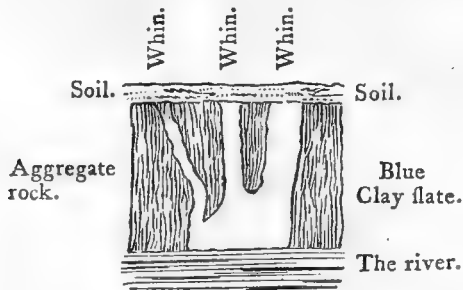

UPON passing this bed of whin, the river ceases to be deeply imbedded in the rocks; but the aggregate rock and the clay flate still continue to be seen for a short distance, in a shelvy acclivity, where they are lost to view in a long narrow plain, deeply covered with a bed of gravel, composed of the debris of the interior mountains. The river here flows over this bed of gravel for a considerable space; and upon this narrow flat, we pass through between two of the most elevated points in the south lateral range of this part of the Grampians. Although the obstruction of this mass of gravel cuts off from inspection the continuity of the last-mentioned rocks, yet the broken and abrupt sides of the mountains, close upon each hand, clearly points out, that this part of the south lateral range is entirely composed of micaceous schistus. Here, we are deprived of the junction of the micaceous schistus with the two former rocks; and the loss of all such

such junctions are always to be much regretted in mineralogical research.

HAVING passed over this narrow plain, I advanced towards a second range of hills, which here form the basis of the central and highest chain. It is at this place where the river so suddenly changes its course from east to south, and where I was under the necessity of leaving its bed, to continue my northern direction towards Mount-Battoc. This, however, I was enabled to do to great advantage, by following up the deep cut bed of a winter torrent, which led me into the direction which I wished to follow.

UPON entering the bed of this torrent, I found that the basis of the hills here entirely consisted of micaceous schistus, much veined with quartz, and much twisted in its texture. The stretch of this rock is here nearly from west to east; and it has a southerly dip of 45 degrees.

IN passing through among those hills towards the central range, I found in several of the beds of the torrents large blocks of reddish-brown porphyry, with scattered masses of micaceous schistus and granite.

IN tracing up one of those torrents, I saw the micaceous-schistus rock and the porphyry both exposed to view, near to each other; and, soon after, in the bed of the same torrent, I came to a cascade which had laid bare both those rocks at a point where they are in contact; and near those a second bed of porphyry made its appearance, in the front of a near hill. From my first view of those, and from their relative positions, I was led to imagine, that they might here alternate in vertical position; but upon more minute inspection, I found that the porphyry constituted vertical dikes, stretching nearly from south to north; which course cuts the line of direction of the Grampians here almost at right angles: and, on the contrary, I found that the micaceous schistus which flanked those dikes of porphyry, had a regular stretch
from.

from west to east, and a southerly dip. To endeavour to have these appearances more fully explained to me, I directed my steps to the brow of that hill, where I had observed the rock laid bare; and in passing along the fronts of the hills from east to west, I soon came to a dike of porphyry similar to those which I had immediately left. This dike is sixty feet broad, stretching nearly from south to north, and flanked upon both sides by micaceous shistus, stretching and dipping as before described. In proceeding farther along the faces of those hills, I found several other dikes of porphyry, of various breadths, and at various distances from each other; but all of them similar in their lines of direction, and the micaceous shistus always interposing between them, through which they seemed to rise. The porphyries of those dikes are generally of a ferruginous colour, tending sometimes to an orange-red, and of various tints of those colours. They have great induration, are coarse-grained, and produce a rough fracture. The particles of quartz which are scattered in their principal masses, are small, amorphous, and are of a ferruginous colour. The particles of felspar are of a light tint of the same colour, and are mostly crystallized. The surface of those dikes are in many places bare, and exposed to the eye for long extents, in their lines of direction; and in all those lines of direction which I have traced, I have never found any of them alter in their breadths, in their verticality, nor in their directions. Their surfaces, in general, consist of oblong square blocks, now loose and unconnected with each other; and, in many places, the lines of fracture of those blocks are so straight, that one might almost suppose that they had been disjoined by the hand of art.

I HAVE often observed, in this district, and in other parts of the Grampians, that the loose and outlying blocks of both granite and of porphyry, (which have not been worn down by attrition),

trition), consist, in general, of oblong square shapes. This observation, when I first made it, led me to imagine, that those rocks here were perhaps stratified. I have, however, as yet, not been able to trace real stratification of those rocks in this district of the Grampians.

UPON some of the summits of those hills which here form the basis of the central range, I first discovered the granite in solid rock. In those situations, the granite is only seen in patches, where the superincumbent rocks have worn off it. These superincumbent rocks, which I here found in contact with the granite, are of two different compositions, and occur on the summits of different hills. The one of those rocks, and the most prevalent one, is the micaceous schistus; the other is the granitelle, or a mixture of quartz and shorl. In some parts of this last-mentioned rock, I perceived a small admixture of hornblende: where this appears in the composition, it perhaps ought to receive the appellation of granitine. In those elevated situations, I found both of those rocks, (especially the micaceous schistus), in a state of decomposition, and fast leaving the granite exposed to the eye.

FROM those appearances, it is to be inferred, that the interior of those hills is composed of granite, which is but thinly coated by the superincumbent rocks.

UPON leaving these hills, which, I have already said, form the basis of the central chain of the Grampians, I regretted very much, that all my endeavours proved abortive to trace out the whole extent, in line, of any one of those dikes of porphyry which intersect their sides. I constantly lost them under peat or other soils, before I could trace them to their contact with the granite. It was my anxious wish to see how those two rocks of porphyry and granite connected with each other at their junction.

IN pursuing my researches towards the summit of Mount Batic, I proceeded up the bed of a torrent, which, after heavy rains, dashes down the immediate side of that mountain. In this bed, the blocks of micaceous schistus and of porphyry, (which I had seen so abundantly scattered among the hills that I had just left), totally disappeared, and no outlyers of any kind were to be seen, excepting some granites, which were scattered in large masses; and in every part, where the torrent had carried off the superincumbent soil, the granite was to be seen in solid rock.

IN my progress towards the summit of this mountain, I fell in with a large face of the native granite rock exposed to the eye. By the cracks in this face being in long-extended horizontal lines, it had at first the appearance of being stratified; but upon a nearer and more minute examination, I found that it was not stratified, and that the cracks which gave it that appearance were only superficial.

AROUND this face were scattered large blocks of granite, which were mostly in oblong square shapes.

SOON after passing this precipice, I gained the summit of the mountain, which, though not very highly elevated, is in this part of the chain the highest of the central range. It is about 3465 feet above the level of the sea; and is entirely composed of a coarse-grained granite, in which shorl sometimes occurs; and its felspar is very generally crystallized.

HAVING here finished the extent of my intended investigation, I beg to be permitted to add, that the line which I have here given the description of, has been traced with much attention, and the true position of each fossil has been most scrupulously attended to, and is correctly placed in the annexed plate.

1850



The Grand Canyon

Mount Hermit, in the center of the *Plateau*, entirely composed of granite

mountains where the granite *gneiss* appears to be *broken*, the *limestone* shales

and a *bed* of *quartz* and *shale* which *rests* on the *granite* and *limestone*

Hermit

Hills form the base of the *Grand Canyon*

limestone shales

limestone shales

The South Fork *Plateau* entirely composed of *limestone*

Plateau

A *limestone* *Plateau* covered with *granite*

limestone shales

limestone shales

limestone shales with the *granite* rock

limestone shales

limestone shales

Hills

limestone shales

limestone shales

Hills form the base of the *Grand Canyon*

limestone shales

limestone shales

limestone shales

limestone shales

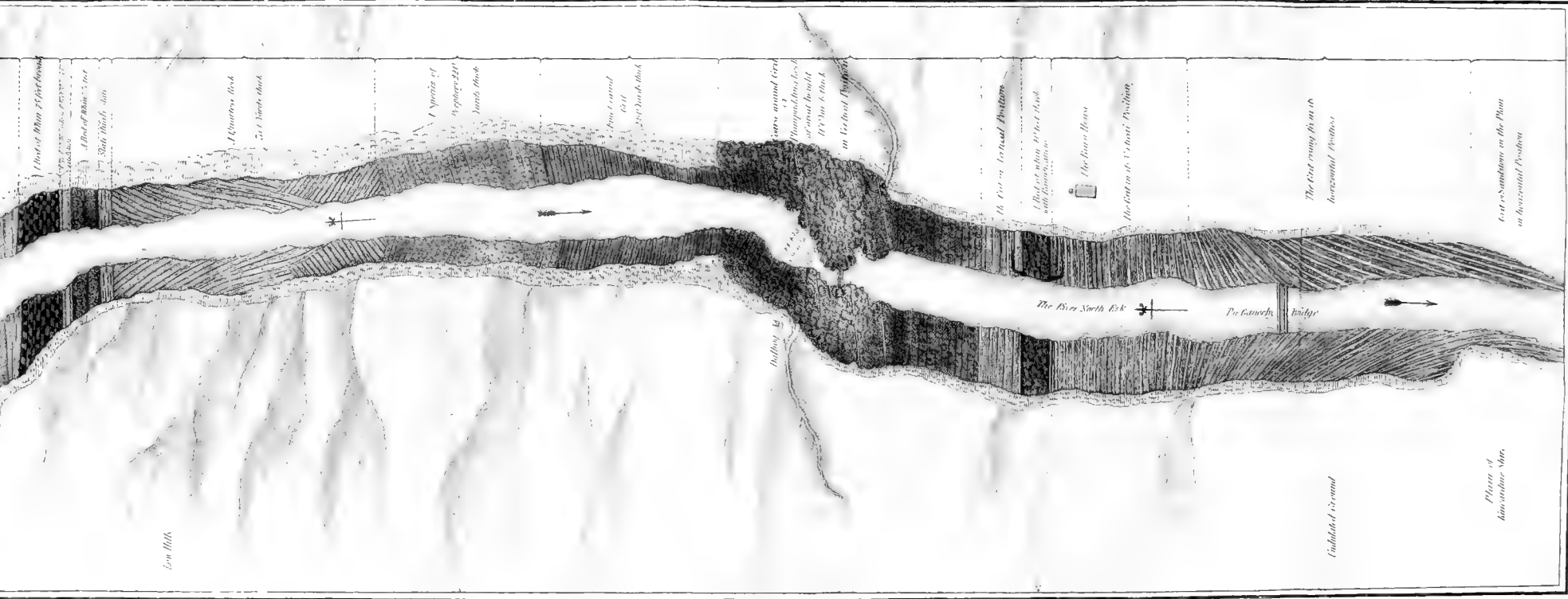

A bed of Blue Limestone

A bed of Blue Limestone

Thin thin bedded

A quantity of
Thin thin bedded

A piece of
Limestone 2 1/2
feet thick

Thin Limestone
bed
2 1/2 feet thick

course around which
the river flows
177 to 180 ft. thick
in vertical position

The cut in vertical position
is about 177 to 180 ft. thick
with horizontal position

The lower floor

The cut in its vertical position

The cut may be in its
horizontal position

The cut is in its
horizontal position

Low Bank

halloo

The River North Esk

The Kinnelby bridge

High Bank

Plate of
the structure

I WISH that some more able pen than mine, would take up the further description of this extended field of geology, so worthy of investigation ; but if none will come forward for that purpose, I may at some future period presume to give to this Society more extended, and more general lines of description of the Grampians, than that which I have now had the honour of submitting to their examination.

II.

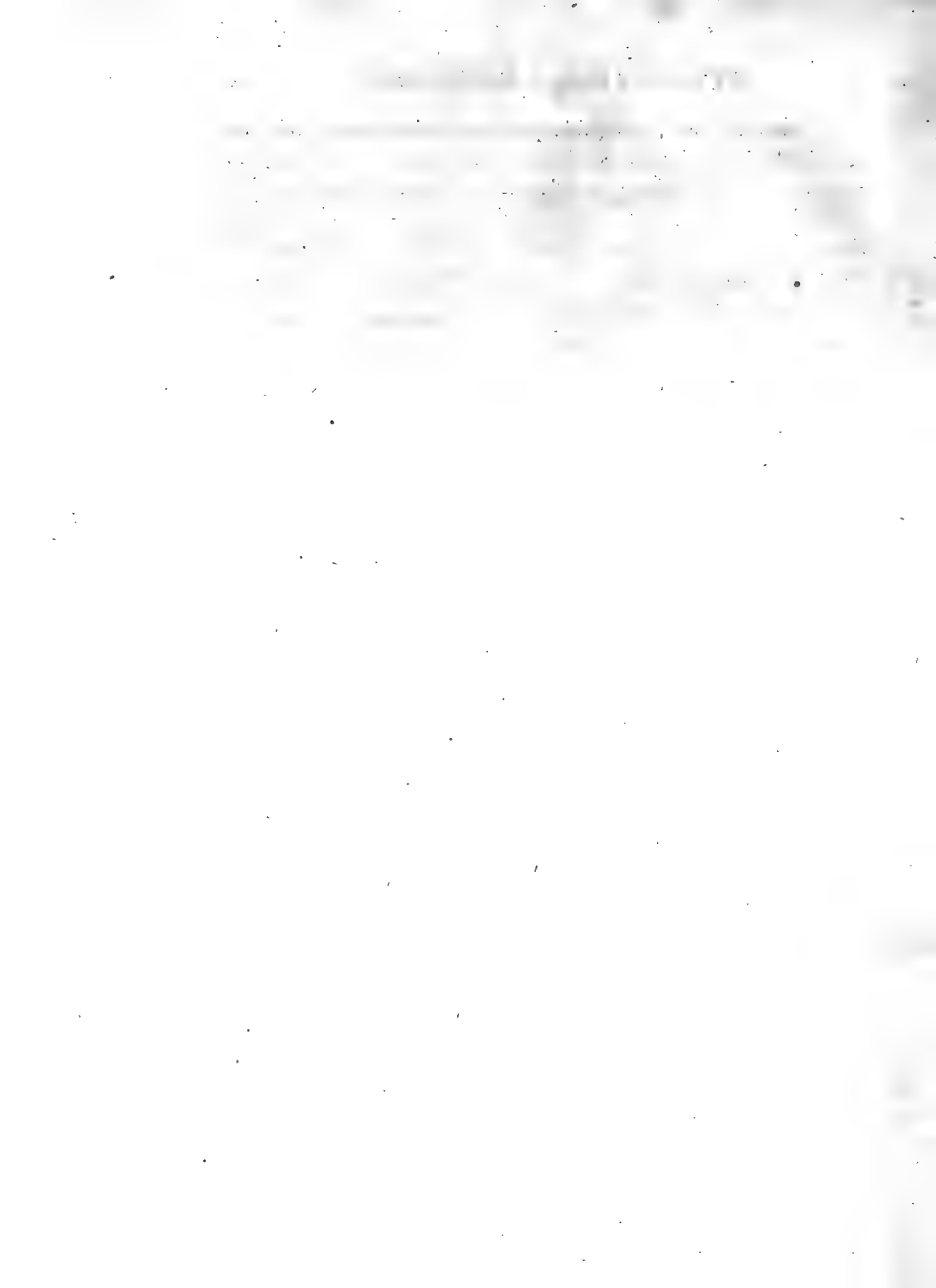

II. A GEOMETRICAL INVESTIGATION of *some curious and interesting Properties of the CIRCLE, &c.* By JAMES GLENIE, Esq;
A. M. F. R. S. LOND. & EDIN.

[Read April 1. 1805.]

DEAR SIR,

Edinburgh, 22d March 1805.

AS the following paper refers in a great measure to the *general theorems* published by your father, I now commit it to your care, and that of my friend Mr PLAYFAIR, Professor of Natural Philosophy. I wish it to be communicated to the Royal Society of Edinburgh, and, if approved of, to be inserted in their Transactions as soon as possible. Indeed, I trust, that even simple as it is, it will not be altogether unacceptable to that learned body.

I am,

Dear Sir,

Most sincerely your, &c.

JAS GLENIE.

Dugald Stewart, Esq; }
Professor of Moral Philosophy. }

THE

THAT truly elegant and inventive geometer the late Dr MATTHEW STEWART, published at Edinburgh, in 1746, without demonstrations, a number of general theorems, of great use in the higher parts of mathematics, and much calculated for improving and extending geometry. Such of them as refer to the circle, and to regular figures inscribed in, and circumscribed about it, have not, as far as I can understand, been yet demonstrated. These, with an endless variety of other theorems, are derivable, as corollaries, from the following general though simple geometrical investigation, that occurred to me fifteen years ago, and which, I suppose, has remained so long unknown and unattended to chiefly on account of its simplicity.

LET A, B, C, &c. (Pl. II. Fig. 1.) be any number of points in the circumference of a circle, and let that number be denoted by n . Let RA, RS, ST, &c. be tangents to the circle, in the points A, B, C, &c.; and let POQ be any diameter. Let Qc, Qd, Qf, &c. be perpendiculars from the point Q to the diameters passing through the points A, B, C, &c., and Pa, Pb, Pe, &c. perpendiculars from the point P to the same diameters.

THEN it is evident, that $\overline{PQ}^2 = \overline{AP}^2 + \overline{AQ}^2 = \overline{BP}^2 + \overline{BQ}^2 = \overline{CP}^2 + \overline{CQ}^2, \text{ \&c.}$ Wherefore $\overline{PQ}^2 \times n = \overline{AP}^2 + \overline{BP}^2 + \overline{CP}^2 + \overline{AQ}^2 + \overline{BQ}^2 + \overline{CQ}^2 + \text{ \&c.}$ But $\overline{AP}^2 = AG \times Aa = PQ \times Aa$, $\overline{BP}^2 = PQ \times Be$, $\overline{CP}^2 = PQ \times Cb$, &c.; and $\overline{AQ}^2 + \overline{BQ}^2 + \overline{CQ}^2 + \text{ \&c.} = PQ \times Ac + Bf + Cd + \text{ \&c.}$ Now Aa, Be, Cb, &c. are respectively equal to perpendiculars drawn from P to the tangents RA, RS, ST, &c., as are Ac, Bf, Cd, &c. equal to perpendiculars drawn from Q to the same tangents. Consequently the sum of all the perpendiculars drawn from the points P and Q to lines touching the circle in the points, A, B, C, &c. is equal to $PQ \times n$, or a multiple of the diameter by n .

THE same may be proved otherwise; for since $Oa = Oc$, $Aa = Gc$, $Aa + Ac =$ the diameter. In like manner, $Be + Bf =$ the diameter, and $Cb + Cd =$ diameter, &c.

IN the same way, it is demonstrated, that if from any two points p, q , in the diameter PQ , equally distant from the centre O , perpendiculars be drawn to the lines touching the circle in the points A, B, C , &c. their sum is equal to a multiple of the diameter by n .

BUT if from any two points V, W , in PQ produced, equally distant from the centre O , lines drawn perpendicular to any diameter B, r , passing through any point of contact B , fall beyond its extremities B, r , the difference of the perpendiculars drawn from W, V , to the line touching the circle in B , is equal to the diameter, and so on.

So also, when perpendiculars from the points V, W in PQ , produced to the diameters passing through the points of contact A, B, C , &c. do not fall beyond the extremities of any of these diameters, perpendiculars from V and W to right lines touching the circle in the points A, B, C , &c. are taken together equal to a multiple of the diameter by the number of the said points.

Cor. 1. Perpendiculars drawn from P and Q , or p and q , to lines touching the circle in the points A, B, C , &c. are together equal to a multiple of the radius by $2n$.

Cor. 2. The sum of perpendiculars drawn from P, Q , or p, q , to the sides of any regular figure circumscribed about the circle, is equal to twice the sum of perpendiculars drawn to the sides of a regular figure of the same number of sides circumscribing the circle from any point within the same regular figure.

Cor. 3. $\frac{\overline{AP}^2 + \overline{BP}^2 + \overline{CP}^2 + \dots}{d} =$ sum of the perpendiculars

drawn from P to right lines touching the circle in the points A, B, C , &c. d denoting the diameter.

OR a third proportional to the diameter and the chord AP , together with a third proportional to the diameter and the chord BP , together with a third proportional to the diameter and the
chord

chord CP, &c. is equal to the sum of the perpendiculars drawn from the point P to right lines touching the circle in the points A, B, C, &c.

$$\text{AND } \frac{\overline{AQ}^2 + \overline{BQ}^2 + \overline{CQ}^2 +, \&c.}{d} = \text{sum of perpendiculars}$$

drawn from Q to the same lines.

AGAIN, since by a well known property of the circle, $\overline{AP}^2 + \overline{AQ}^2 = \overline{BP}^2 + \overline{BQ}^2 = \overline{CP}^2 + \overline{CQ}^2 = \&c. = 2r^2 + 2\overline{Op}^2$, r denoting radius, the sum of the squares of lines drawn from the points A, B, C, &c. to any two points p, q , in the diameter equally distant from the centre, is $= 2nr^2 + 2n \times \overline{Op}^2 =$ a multiple of r^2 , by twice the number of the points A, B, C, &c. together with the same multiple of the square of Op or Oq .

IN like manner, $\overline{AV}^2 + \overline{AW}^2 + \overline{BV}^2 + \overline{BW}^2 + \overline{CV}^2 + \overline{CW}^2 +, \&c. = 2nr^2 + 2n \times \overline{Ov}^2 =$ a multiple of r^2 by twice the number of the points A, B, C, &c., together with the same multiple of Ov^2 or Ow^2 .

AND since the squares of the chords AP, BP, CP, &c. are together equal to the sum of the squares of the perpendiculars drawn from P to the right lines touching the circle in the points A, B, C, &c. together with the sum of the squares of the perpendicular distances of P from the diameters passing through these points, the sum of the squares of $Ap, Bp, Cp, \&c.$ is in like manner equal to the sum of the squares of perpendiculars from p to these lines, together with the sum of the squares of the perpendicular distances from p to the said diameters.

IN like manner, $\overline{Aq}^2 + \overline{Bq}^2 + \overline{Cq}^2 +, \&c. =$ sum of squares of perpendiculars from q to the lines touching the circle in A, B, C, &c. together with the sum of the squares of the perpendicular distances of q from the diameters passing through A, B, C, &c.

WHEREFORE

WHEREFORE the squares of the perpendicular distances of either P or Q, from diameters passing through the points of contact A, B, C, &c., are, taken together, equal to the excess of the rectangle under half the diameter PQ, and the sum of perpendiculars from P and Q to right lines touching the circle in the points A, B, C, &c. above half the sum of the squares of said perpendiculars = $nr^2 - rs$, (s being equal to the sum of perpendiculars from O, as, in what follows, to right lines touching the circle, of which OQ is the diameter, in the points $c, d, f, \&c.$). And the sum of the squares of these perpendicular distances from both P and Q, is = $2nr^2 - 2rs$. This is also evident, from all angles in a semicircle being equal to right ones.

For $\overline{AP^2} + \overline{AQ^2} + \overline{BP^2} + \overline{BQ^2} + \overline{CP^2} + \overline{CQ^2} + \&c. = n \times \overline{PQ^2} = 4nr^2$; and $4nr^2 - 2nr^2 - 2rs = 2nr^2 - 2rs$.

CONSEQUENTLY, when the whole circle is divided into equal parts, in the points A, B, C, &c. $\overline{Ap^2} + \overline{Bp^2} + \overline{Cp^2} + \&c. = \overline{Aq^2} + \overline{Bq^2} + \overline{Cq^2} + \&c. = nr^2 + n \times \overline{Op^2}$; and $\overline{AV^2} + \overline{BV^2} + \overline{CV^2} + \&c. = \overline{AW^2} + \overline{BW^2} + \overline{CW^2} + \&c. = nr^2 + n \times \overline{OV^2}$. For the sum of perpendiculars drawn from p to the sides of any regular figure circumscribing the circle, is then equal to the sum of the perpendiculars drawn from q to the sides of the same figure. The same observation holds with regard to perpendiculars drawn from the points V, W.

FROM the foregoing general investigation, when the circle is supposed to be equally divided in the points A, B, C, &c. DR STEWART'S first, second, third, and eleventh theorems can be immediately derived.

I SHALL, however, proceed regularly with the investigation; and, in the first place, take the squares of the perpendiculars from P and Q to the right lines touching the circle in the points A, B, C, &c. which perpendiculars are respectively equal to Aa, Ac; Bf, Be; Cd, Cb; &c.

$$\begin{aligned} \text{Now } \overline{Ac}^2 + \overline{Aa}^2 &= \overline{r+cO}^2 + \overline{r-cO}^2 = 2r^2 + 2 \times \overline{cO}^2 \\ \overline{Bf}^2 + \overline{Be}^2 &= \overline{r+Of}^2 + \overline{r-Of}^2 = 2r^2 + 2 \times \overline{Of}^2 \\ \overline{Cd}^2 + \overline{Cb}^2 &= \overline{r+Od}^2 + \overline{r-Od}^2 = 2r^2 + 2 \times \overline{Od}^2 \\ &\quad \&c. \qquad \qquad \qquad \&c. \qquad \qquad \qquad \&c. \end{aligned}$$

WHEREFORE the sum of the squares of perpendiculars from P, Q to lines touching the circle in the points A, B, C, &c. is $= 2n \times r^2 + 2 \times \overline{Oc}^2 + \overline{Of}^2 + \overline{Od}^2 + \&c.$ But the points $c, d, f,$ are in the circumference of a circle, of which the diameter is OQ or r , and by Cor. 3. the sum of $\overline{Oc}^2 + \overline{Of}^2 + \overline{Od}^2 + \&c. = \text{OQ} \times$ into the sum of perpendiculars drawn from O to lines touching the circle, of which OQ is the diameter, in the points $c, d, f,$ &c. Call the sum of these perpendiculars s . Then we have the sum of the squares of perpendiculars drawn from P, Q to lines touching the circle APQ in the points A, B, C, &c. $= 2nr^2 + 2rs = (\text{Cor. 3.}) \frac{\overline{AP}^4 + \overline{BP}^4 + \overline{CP}^4 + \&c. + \overline{AQ}^4 + \overline{BQ}^4 + \overline{CQ}^4 + \&c.}{d^2}$

When the circumference is divided into equal parts by the points A, B, C, &c. or the angles at O are equal, $s = \frac{n}{2} \times \text{OQ}$ or $\frac{n}{2} \times r$ and $2nr^2 + 2rs = 3nr^2$.

IF a regular figure be inscribed in the circle, having its angles at the points A, B, C, &c. or a regular figure be circumscribed about the circle, having its sides tangents to it in the points A, B, C, &c. we get from the general expression

$$\frac{\overline{AP}^4 + \overline{BP}^4 + \overline{CP}^4 + \&c.}{r} \text{ or } \frac{\overline{AQ}^4 + \overline{BQ}^4 + \overline{CQ}^4 + \&c.}{r} = 4nr^3$$

$+ 4r^2s = 4nr^3 + 2nr^3 = 6nr^3$, or third proportionals to radius, the chords drawn from either P or Q to the points A, B, C, &c. and the cubes of these chords equal, when taken together, to six times a multiple of the cube of radius by the number

ber

ber of the sides of the inscribed or circumscribed figure; or to speak algebraically, the sum of the fourth powers of the chords is equal to six times a multiple of the fourth power of the semi-diameter of the circle, by the number of the sides of the figure. This is Dr STEWART'S 23d theorem.

IN like manner,

$$\begin{aligned} \overline{Ac}^3 + \overline{Aa}^3 &= \overline{r + Oc}^3 + \overline{r - Oc}^3 = 2r^3 + 6r \times \overline{Oc}^2 \\ \overline{Bf}^3 + \overline{Be}^3 &= \overline{r + Of}^3 + \overline{r - Of}^3 = 2r^3 + 6r \times \overline{Of}^2 \\ \overline{Cd}^3 + \overline{Cb}^3 &= \overline{r + Od}^3 + \overline{r - Od}^3 = 2r^3 + 6r \times \overline{Od}^2 \\ \&c. \qquad \qquad \qquad \&c. \qquad \qquad \qquad \&c. \end{aligned}$$

And the cubes of perpendiculars from P and Q to right lines touching the circle in the points A, B, C, &c. are taken together

$$= 2nr^3 + 6r \times \overline{Oc}^2 + \overline{Of}^2 + \overline{Od}^2 + \&c. = (\text{by Corollary 3.})$$

$$\frac{\overline{AP}^6 + \overline{BP}^6 + \overline{CP}^6 + \&c. + \overline{AQ}^6 + \overline{BQ}^6 + \overline{CQ}^6 + \&c.}{d^3}$$

$$\text{BUT } \overline{Oc}^2 + \overline{Of}^2 + \overline{Od}^2 + \&c. = \frac{nr^2}{2}, \text{ when the circumference}$$

is equally divided in the points A, B, C, &c. or when a regular figure is circumscribed about the circle, with its sides touching the same in said points. Wherefore the cubes of perpendiculars from P and Q to the sides of a regular figure of a greater number of sides than three circumscribed about the circle, are taken together = $5nr^3$. This is Dr STEWART'S 19th theorem.

AND if a regular figure of a greater number of sides than three be inscribed in the circle, having its angles in the points A, B, C, &c. third proportionals to the cube of the diameter and the cubes of chords drawn from P and Q to the points A, B, C, &c. will, taken together, be equal to $5nr^3$; or third proportionals to the cube of the diameter and chords drawn from either P or Q to the said angular points, will taken together, be = $\frac{5nr^3}{2}$;

or, to speak algebraically, the sum of the sixth power of chords drawn from either P or Q to the said points, will be equal to twenty times a multiple of the sixth power of radius, by the number of the sides of the inscribed figure.

IN like manner,

$$\frac{\overline{Ac}^4 + \overline{Aa}^4}{r} = \frac{\overline{r+Oc}^4 + \overline{r-Oc}^4}{r} = 2r^3 + 12r \times \overline{Oc}^2 + \frac{2 \times \overline{Oc}^4}{r};$$

$$\frac{\overline{Bf}^4 + \overline{Be}^4}{r} = \frac{\overline{r+Of}^4 + \overline{r-Of}^4}{r} = 2r^3 + 12r \times \overline{Of}^2 + \frac{2 \times \overline{Of}^4}{r}$$

$$\frac{\overline{Cd}^4 + \overline{Cb}^4}{r} = \frac{\overline{r+Od}^4 + \overline{r-Od}^4}{r} = 2r^3 + 12r \times \overline{Od}^2 + \frac{2 \times \overline{Od}^4}{r}$$

&c.

&c.

&c.

And third proportionals to radius, perpendiculars from P and Q to right lines touching the circle in the points A, B, C, &c. and the cubes of said perpendiculars are, taken together, equal to

$$2nr^3 + 12r \times \overline{Oc}^2 + \overline{Of}^2 + \overline{Od}^2 + \&c. + 2 \times \frac{\overline{Oc}^4 + \overline{Of}^4 + \overline{Od}^4 + \&c.}{r}$$

$$= (\text{by Cor. 3.}) \frac{\overline{AP}^3 + \overline{BP}^3 + \overline{CP}^3 + \&c.}{d^4 \times r} + \frac{\overline{AQ}^3 + \overline{BQ}^3 + \overline{CQ}^3 + \&c.}{d^4 \times r}$$

BUT $\overline{Oc}^2 + \overline{Of}^2 + \overline{Od}^2 + \&c. = \frac{nr^2}{2}$ when the circumference is equally divided in the points A, B, C, &c. or when a regular figure is circumscribed about the circle, with its sides touching the same in said points, and $12r \times \frac{nr^2}{2} = 6nr^3$. Also

$$2 \times \frac{\overline{Oc}^4 + \overline{Of}^4 + \overline{Od}^4 + \&c.}{r} \text{ is then } = \frac{3nr^3}{4}. \text{ Wherefore these}$$

third proportionals are taken together equal to $8nr^3 + 3 \frac{nr^3}{4} =$

$$\frac{35nr^3}{4}; \text{ and four times their aggregate is equal to } 35nr^3. \text{ Or,}$$

to

to speak algebraically, eight times the sum of the fourth powers of perpendiculars from either P or Q to the sides of a regular figure of a greater number of sides than four circumscribed about the circle, and touching it in the points A, B, C, &c. are equal to thirty-five times the multiple of the fourth power of radius by the number of the sides of the figure. This is Dr STEWART's 25th theorem.

AND if a regular figure of a greater number of sides than four be inscribed in the circle, having its angles in the points A, B, C, &c. the eighth powers of the chords drawn from either P or Q to the points A, B, C, &c. (to speak algebraically) is equal to $70nr^3 = n \times \frac{1 \cdot 3 \cdot 5 \cdot 7}{1 \cdot 2 \cdot 3 \cdot 4} \cdot 2^4 \cdot r^8 =$ seventy times a multiple of the eighth power of radius by the number of the sides of the figure.

In like manner,

$$\frac{r + Oc^5 + r - Oc^5}{r^2} = 2r^3 + 20r \times Oc^2 + 10 \times \frac{Oc^4}{r},$$

$$\frac{r + Of^5 + r - Of^5}{r^2} = 2r^3 + 20r \times Of^2 + 10 \times \frac{Of^4}{r},$$

$$\frac{r + Od^5 + r - Od^5}{r^2} = 2r^3 + 20r \times Od^2 + 10 \times \frac{Od^4}{r}$$

&c.

&c.

WHEREFORE $\frac{r + Oc^5 + r - Oc^5}{r^2} + \frac{r + Of^5 + r - Of^5}{r^2} + \frac{r + Od^5 + r - Od^5}{r^2}$

+ &c. = $2nr^3 + 10nr^3 + \frac{15nr^3}{4} = \frac{63nr^3}{4}$ equal (by Cor. 3.) to

$\frac{\overline{AP}^{10} + \overline{BP}^{10} + \overline{CP}^{10} + \&c. + \overline{AQ}^{10} + \overline{BQ}^{10} + \overline{CQ}^{10} + \&c.}{d^5 r^2}$, when

the circle is equally divided in the points A, B, C, &c.

AND

AND generally when m is any integer whatsoever, we have

$$\frac{\overline{r+Oc}^m + \overline{r-Oc}^m}{r^{m-3}} + \frac{\overline{r+Of}^m + \overline{r-Of}^m}{r^{m-3}} + \frac{\overline{r+Od}^m + \overline{r-Od}^m}{r^{m-3}}$$

$$+ \&c. \text{ equal to } 2nr^3 + \frac{m}{1} \cdot \frac{m-1}{1} \cdot r \times \overline{Oc^2 + Of^2 + Od^2} + \&c. +$$

$$\frac{m}{1} \cdot \frac{m-1}{1} \cdot \frac{m-2}{3} \cdot \frac{m-3}{4} \times \frac{\overline{Oc^4 + Of^4 + Od^4} + \&c.}{r} + \frac{m}{1} \cdot \frac{m-1}{1} \cdot \frac{m-2}{3}$$

$$\frac{m-3}{4} \cdot \frac{m-4}{5} \cdot \frac{m-5}{6} \times \frac{\overline{Oc^6 + Of^6 + Od^6} + \&c.}{r^3} + \&c. = (\text{Cor. 3.})$$

$$\frac{\overline{AP}^{2m} + \overline{BP}^{2m} + \overline{CP}^{2m} + \&c.}{d^m r^{m-3}} + \frac{\overline{AQ}^{2m} + \overline{BQ}^{2m} + \overline{CQ}^{2m} + \&c.}{d^m r^{m-3}};$$

which, when the circle is equally divided in the points A, B, C, &c. by the circumscription or inscription of a regular figure, coincides with the 36th and 38th of Dr STEWART'S general theorems.

AND universally if m have to l any ratio whatsoever,

$$\frac{\overline{r+Oc}^{\frac{m}{l}} + \overline{r-Oc}^{\frac{m}{l}}}{r^{\frac{m}{l}-3}} + \frac{\overline{r+Of}^{\frac{m}{l}} + \overline{r-Of}^{\frac{m}{l}}}{r^{\frac{m}{l}-3}} + \frac{\overline{r+Od}^{\frac{m}{l}} + \overline{r-Od}^{\frac{m}{l}}}{r^{\frac{m}{l}-3}} + \&c.$$

$$\text{is } = 2nr^3 + \frac{m}{l} \cdot \frac{m-l}{l} \cdot r \times \overline{Oc^2 + Of^2 + Od^2} + \&c. + \frac{m}{l} \cdot \frac{m-l}{l} \cdot \frac{m-2l}{3l} \cdot$$

$$\frac{m-3l}{4l} \times \frac{\overline{Oc^4 + Of^4 + Od^4} + \&c.}{r} + \frac{m}{l} \cdot \frac{m-l}{l} \cdot \frac{m-2l}{3l} \cdot \frac{m-3l}{4l} \cdot \frac{m-4l}{5l}$$

$$\frac{m-5l}{6l} \times \frac{\overline{Oc^6 + Of^6 + Od^6} + \&c.}{r^3} + \&c. \&c.$$

THIS last theorem, or expression, is more general than any of Dr STEWART'S theorems, and will furnish an endless number of new and curious infinite series, with their summations. It may also be extended to the chords AP, BP, &c. and expressed in terms of them. And as to the truth of the binomial

nomial and residual theorems, when m has to l the ratio of any two homogeneous magnitudes whatsoever, I must refer the reader to my general demonstration of both in Baron MASERES's *Scriptores Logarithmici*, vol. 5. and to some of the geometrical formulæ in my *Universal Comparison*.

IN like manner, if $pg, pb, pi, \&c.$ be perpendiculars respectively to $BO, CO, AO, \&c.$ we have $\overline{r+Oi^2} + \overline{r-Oi^2} + \overline{r+Og^2} + \overline{r-Og^2} + \overline{r+Ob^2} + \overline{r-Ob^2} + \&c. = 2nr^2 + 2 \times \overline{Oi^2 + Og^2 + Ob^2} + \&c. = 2nr^2 + n \cdot \overline{Op^2}$, when the circle is equally divided in the points $A, B, C, \&c.$ or when a regular figure is circumscribed about it, with its sides touching it in these points. This is Dr STEWART's third theorem, of which he gives a demonstration of considerable length.

IN like manner,

$\overline{r+Oi^3} + \overline{r-Oi^3} + \overline{r+Og^3} + \overline{r-Og^3} + \overline{r+Ob^3} + \overline{r-Ob^3} + \&c.$ are equal to $2nr^3 + 6r \times \overline{Oi^2 + Og^2 + Ob^2} + \&c. = 2nr^3 + 3r \times \overline{Op^2}$, when the circle is equally divided in the points, $A, B, C, \&c.$ or when a regular figure circumscribing it touches it in these points. This is Dr STEWART's 20th theorem.

IN like manner,

$\frac{\overline{r+Oi^4} + \overline{r-Oi^4}}{r} + \frac{\overline{r+Og^4} + \overline{r-Og^4}}{r} + \frac{\overline{r+Ob^4} + \overline{r-Ob^4}}{r} + \&c.$ is equal to $2nr^3 + 12r \times \overline{Oi^2 + Og^2 + Ob^2} + \&c. + 2 \times \frac{\overline{Oi^4} + \overline{Og^4} + \overline{Ob^4} + \&c.}{r} = 2nr^3 + 6r \times \overline{Op^2} \times n + \frac{3n \cdot \overline{Op^4}}{4r}$,

when the circle is equally divided in the points $A, B, C, \&c.$ or when a regular figure, circumscribing it, touches it in these points. And a multiple of this by four, or eight times the aggregate of
third

third proportionals to r , the perpendiculars from either p or q to the sides of the regular circumscribing figure, and the cubes of these perpendiculars is equal to $8nr^3 + 24nr \times \overline{Op}^2 + 3n \times \frac{\overline{Op}^4}{r}$; or, speaking algebraically, eight times the sum of the fourth

powers of perpendiculars from either p or q are equal to $8nr^4$, together with 24 times a multiple by n of the fourth power of the line whose square is equal to $r \times \overline{Op}$, together with thrice a multiple by n of \overline{Op}^4 . This is Dr STEWART'S 26th theorem.

IN like manner,

$$\frac{r + \overline{Oi}^5}{r^2} + \frac{r - \overline{Oi}^5}{r^2} + \frac{r + \overline{Og}^5}{r^2} + \frac{r - \overline{Og}^5}{r^2} + \frac{r + \overline{Ob}^5}{r^2} + \frac{r - \overline{Ob}^5}{r^2} + \&c.$$

$$\text{are} = 2nr^3 + 20r \times \frac{\overline{Oi}^2 + \overline{Og}^2 + \overline{Ob}^2 + \&c.}{r} + 10 \times \frac{\overline{Oi}^4 + \overline{Og}^4 + \overline{Ob}^4 + \&c.}{r}$$

$$= 2nr^3 + 10nr \times \overline{Op}^2 + \frac{15n \cdot \overline{Op}^4}{4r} \text{ when the circle is equally}$$

divided in the points A, B, C, &c. or when a regular figure circumscribing it touches it in these points.

AND generally when m is any integer whatsoever,

$$\frac{r + \overline{Oi}^m}{r^{m-3}} + \frac{r - \overline{Oi}^m}{r^{m-3}} + \frac{r + \overline{Og}^m}{r^{m-3}} + \frac{r - \overline{Og}^m}{r^{m-3}} + \frac{r + \overline{Ob}^m}{r^{m-3}} + \frac{r - \overline{Ob}^m}{r^{m-3}}$$

$$+ \&c. \text{ is} = 2nr^3 + \frac{m \cdot m-1}{1} \cdot r \times \frac{\overline{Oi}^2 + \overline{Og}^2 + \overline{Ob}^2 + \&c.}{r} + \frac{m \cdot m-1}{1} \cdot \frac{m-1}{1}$$

$$\frac{m-2}{3} \cdot \frac{m-2}{4} \times \frac{\overline{Oi}^4 + \overline{Og}^4 + \overline{Ob}^4 + \&c.}{r} + \frac{m \cdot m-1}{1} \cdot \frac{m-2}{3} \cdot \frac{m-3}{4}$$

$$\frac{m-4}{5} \cdot \frac{m-5}{6} \times \text{into } \frac{\overline{Oi}^6 + \overline{Og}^6 + \overline{Ob}^6 + \&c.}{r} + \&c. \&c.; \text{ which,}$$

when the circle is equally divided in the points A, B, C, &c. or when

when a regular figure circumscribing it touches it in said points, gives Dr STEWART's 37th theorem, since the same reasoning and mode of demonstration holds good in regard to half the amount of this expression, whether the points p and q be in PQ , or in PQ produced.

AND universally if m have to l any ratio whatsoever,

$$\frac{r + Oi^{\frac{m}{l}} + r - Oi^{\frac{m}{l}}}{r^{\frac{m}{l}-3}} + \frac{r + Og^{\frac{m}{l}} + r - Og^{\frac{m}{l}}}{r^{\frac{m}{l}-3}} + \frac{r + Ob^{\frac{m}{l}} + r - Ob^{\frac{m}{l}}}{r^{\frac{m}{l}-3}} + \&c.$$

$$= 2nr^3 + \frac{m}{l} \cdot \frac{m-l}{l} \cdot r \times \overline{Oi^2} + \overline{Og^2} + \overline{Ob^2} + \&c. + \frac{m}{l} \cdot \frac{m-l}{l} \cdot \frac{m-2l}{3l}$$

$$\frac{m-3l}{4l} \cdot \frac{\overline{Oi^4} + \overline{Og^4} + \overline{Ob^4} + \&c.}{r} + \frac{m}{l} \cdot \frac{m-l}{l} \cdot \frac{m-2l}{3l} \cdot \frac{m-3l}{4l} \cdot \frac{m-4l}{5l}$$

$$\frac{m-5l}{6l} \cdot \times \text{into } \frac{\overline{Oi^6} + \overline{Og^6} + \overline{Ob^6} + \&c.}{r^3} + \&c. \&c.$$

THIS last theorem or expression is more general than any of Dr STEWART's theorems, and from it may easily be derived an endless number of new and curious infinite series, with their summations.

IT is almost needless for me to observe, that besides these theorems of Dr MATTHEW STEWART, an unlimited number of other theorems, respecting figures both regular and irregular, circumscribing and inscribed in the circle, may easily be derived from the foregoing investigation, as well as a great number of geometrical infinite series, with their summations. And as to theorems respecting given points, right lines and figures either regular or irregular, given by position, and right lines intersecting each other either in one point or in different points in angles either equal or unequal, that are deducible from it, they are innumerable.

Now, let a circle (Fig. 2.) be divided into an uneven number of equal parts, by the points A, B, C, D, E, &c. and let PQ be any diameter; from P let Pa, Pb, Pc, Pd, Pe, &c. be drawn perpendicular to the diameters passing through the points A, B, C, &c. and from Q let Qe, Qf, Qg, Qh, Qi, &c. be perpendicular to the same diameters.

THEN it is evident, that Aa, Ae are respectively equal to perpendiculars drawn from P, Q, to a tangent to the circle in the point A; and since $Oa = Oe$, their sum $Aa + Ae = \overline{r - Oa} + \overline{r + Oa}$. In like manner, the sum of the perpendiculars from P, Q to the tangent at B is $= \overline{r - Ob} + \overline{r + Ob}$, to the tangent at C is $= \overline{r - Oc} + \overline{r + Oc}$, to the tangent at D is $= \overline{r - Od} + \overline{r + Od}$, and to the tangent at E is $= \overline{r - Oe} + \overline{r + Oe}$. But $r - Oa + r - Ob + r - Oc + r - Od + r - Oe = r + Oa + r + Ob + r + Oc + r + Od + r + Oe = 2 \times \overline{Oa + Ob + Oc + Od + Oe}$ and $Oa + Oe = Ob + Od = Oc + Oe$, and since $\overline{r - Oa}^2 + \overline{r - Ob}^2 + \overline{r - Oc}^2 + \overline{r - Od}^2 + \overline{r - Oe}^2 = \overline{r + Oa}^2 + \overline{r + Ob}^2 + \overline{r + Oc}^2 + \overline{r + Od}^2 + \overline{r + Oe}^2$, we have this equation $4 \times \overline{r \times Ob + r \times Od} = 4 \times \overline{r \times Oa + r \times Oc + r \times Oe}$, or $Ob + Od = Oa + Oc + Oe$.

BUT if from a point in the circumference of a circle, perpendiculars be drawn to the alternate sides of a regular figure of an even number of sides circumscribing the circle, or, which comes to the same thing, beginning with any one side, perpendiculars be drawn to the 1st, 3d, 5th, 7th, &c. sides, the sum of these perpendiculars, the sum of their squares, the sum of their cubes,

&c. to the sum of their $\frac{n}{2} - 1^{\text{th}}$ or $\frac{n - 2^{\text{th}}}{2}$ powers, is respectively

equal to the sum of the perpendiculars drawn from the same point

point to the other sides, viz. the 2d, 4th, 6th, 8th, &c. the sum of their squares, the sum of their cubes, &c. to the sum of their

$\frac{n-2}{2}$ powers, but not in powers above $\frac{n-2}{2}$ (n being the num-

ber of the sides).

THUS for instance, if a regular hexagon circumscribe a circle, and from any point in the circumference perpendiculars be drawn to the alternate sides, that is, to the sides of an equilateral triangle circumscribing it, the sum of these perpendiculars, and the sum of their squares, are respectively equal to the sum of the perpendiculars drawn to the other three sides, and the sum of their squares. For the sum of the perpendiculars to the three sides of an equilateral triangle, is equal to half the sum of the perpendiculars to the sides of the hexagon, and the sum of their squares in the one, equal to half the sum of their squares in the other. But this does not hold in regard to the sum of their cubes, as the sum of the cubes of perpendiculars to the sides of the triangle is not invariable.

IN like manner, if perpendiculars be drawn from a point in the circumference to any four sides of a regular circumscribing octagon, taking them alternately, that is, to the sides of a circumscribing square, their sum, the sum of their squares, and the sum of their cubes, are respectively equal to the sum of perpendiculars to the other four sides, the sum of their squares and the sum of their cubes. But this does not hold in regard of the sum of their fourth powers, which to the sides of a square are not invariable.

IN like manner, the sum of perpendiculars to the alternate sides of a regular circumscribing decagon, that is, to the sides of a pentagon, the sum of their squares, the sum of their cubes, and the sum of their fourth powers, are respectively equal to the

sum, the sum of the squares, the sum of the cubes, and the sum of the fourth powers of perpendiculars to the other five sides. But this equality does not hold in the fifth powers, which to the sides of a pentagon are not invariable. For $\frac{10-2}{2} = 4$. And so on.

N. B. THE same holds true if the perpendiculars be drawn from any point within the figure for odd powers, and either within or without, in even ones.

BUT as it was observed in the preceding page, that the equality between the sum of the powers of perpendiculars, drawn from any point in the circumference of a circle, to the alternate sides of any regular figure of an even number of sides, and the sum of the powers of perpendiculars drawn from the same point to the other sides, existed only to the $\frac{n-2^{\text{th}}}{2}$ power; so the equality between the sum of the powers of perpendiculars drawn from the extremities P and Q of any diameter to the sides of a regular figure of an odd number of sides circumscribing the circle, and the sum of perpendiculars from either of these, or any point in the circumference, to the sides of a regular circumscribing figure of double the number of sides, exists only to the $\frac{n-2^{\text{th}}}{2}$ power.

A WIDE field is here opened for the geometrical solution of both determinate and indeterminate problems.

FOR instance, having two equal right lines given, to cut one into two parts, and the other into three, so that the sum of the squares on the two parts, into which the one is cut, shall be equal

equal to the sum of the squares on the three parts, into which the other is cut.

SOLUTION.

WITH radius equal to one-third part of either of the given lines describe a circle. If a regular hexagon circumscribe it, perpendiculars drawn from the point where any side of the hexagon touches the circle, to the other five sides, are respectively equal to the parts into which the two given equal right lines are required to be divided. Calling the side, from a point in which the perpendiculars are drawn, the 1st, the perpendiculars drawn to the 3d and 5th are the parts, into which one of the two equal given right lines is cut, and those drawn to the 2d, 4th, and 6th sides, the three parts into which the other given line is cut.

N. B. If the perpendiculars be drawn from any point in the circumference, that is not one of the points of contact, three of them taken alternately, are together equal to the other three, and equal to either of the given lines, and the sum of their squares equal to the sum of the squares of the other three. And if they be drawn from a point in the circumference equally distant from two points of contact, the 1st = the 6th, the 2d = the 5th, and 3d = the 4th.

AGAIN, let it be required to divide each of two equal given right lines into four unequal parts, so that none of the parts of the one shall be equal to any of the parts of the other, but the sum of the squares of the parts of the one shall be equal to the sum of the squares of the parts of the other, and also the sum of the cubes of the parts of the one equal to the sum of the cubes of the parts of the other.

SOLUTION.

SOLUTION.

WITH a fourth part of either of the equal given right lines as radius describe a circle. If a regular decagon circumscribe the circle, and from any point in the circumference, that is neither one of the points, where the sides of the figure touch the circle, nor at an equal distance between the points of contact, perpendiculars be drawn to the sides of the octagon, these taken alternately are the parts into which the given right lines are required to be divided.

IF the point coincide with one of the points of contact, one of the given lines is cut into three parts, and the other into four.

IF the point be equally distant from two points of contact, the 1st perpendicular is = the 8th, the 2d = 7th, the 3d = 6th, and the 4th = 5th. $\frac{3-2}{2} = \frac{6}{2} = 3$ the highest power.

WITH such problems one might proceed without end.

SINCE (fig. I.) $\overline{AP}^2 + \overline{BP}^2 + \overline{CP}^2 + \&c. \overline{AQ}^2 + \overline{BQ}^2 + \overline{CQ}^2 + \&c.$ are equal to the squares of lines drawn to P and Q from the angles of a regular inscribed figure of the same number of sides with the irregular circumscribing figure, or from the points where the sides of a regular circumscribing figure touch the circle, it is evident, that the sum of the squares of perpendiculars drawn from P and Q to the sides of any circumscribing figure, regular or irregular, of a given number n of sides, together with the squares of the perpendicular distances of P and Q from the diameters passing through the points of contact A, B, C, &c. viz. $\overline{Pa}^2 + \overline{Pb}^2 + \overline{Pe}^2 + \&c. + \overline{Qc}^2 + \overline{Qd}^2 + \overline{Qf}^2 + \&c. = 2 \times \overline{Pa}^2 + \overline{Bb}^2 + \overline{Pe}^2 + \&c.$ is an invariable quantity. For $\overline{Pa}^2 + \overline{aO}^2 = \overline{Pb}^2 + \overline{bO}^2 = \overline{Pe}^2 + \overline{eO}^2 = \overline{PO}^2$ whether the angles

angles at O formed by the diameters passing through the points of contact A, B, C, &c. be equal or unequal, or whether the circumference of the circle, of which the diameter is PO, be equally or unequally divided in the points *a, b, e,* &c.; and the sum of perpendiculars from P and O, to the sides of a circumscribing figure, touching this circle in the points *a, b, e,* &c. is the same whether the figure be regular or irregular.

OTHERWISE,

$Aa + Ac = 2r : 4r^2 = \overline{Aa^2} + \overline{Ac^2} (\overline{aG^2}) + 2Aa \times aG$
 $(2 \times \overline{Pa^2})$. In like manner, $4r^2 = \overline{Cb^2} + \overline{Cd^2} (\overline{bb^2}) + 2Cb$
 $\times bb (2 \times \overline{Pb^2})$ and so on: $4nr^2 = \overline{Aa^2} + \overline{Ac^2} + \overline{Cb^2} +$
 $\overline{Cd^2} + \overline{Be^2} + \overline{Bf^2} + \&c. + 2 \times \overline{Pa^2} + \overline{Pb^2} + \overline{Pe^2} + \&c.$
 whether the angles AOB, BOC, &c. at O be equal or unequal.

IN like manner, the sum of the cubes of perpendiculars drawn from P and Q to the sides of any circumscribing figure, regular or irregular, of a given number *n* of sides, together with thrice the solid, which has the squares of perpendiculars from P and Q to the diameters passing through A, B, C, &c. for its base, and *r* for its altitude, is an invariable quantity; that is, $2nr^3 + 6r \times$
 $\overline{Oa^2} + \overline{Ob^2} + \overline{Oc^2} + \&c. + \overline{Pa^2} + \overline{Pb^2} + \overline{Pe^2} + \&c.$ is an invariable quantity, being $= 2nr^3 + 6r \times n \times \overline{PO^2} = 8nr^3 = n \times$
 $\frac{2r^3}{3}$. For $\overline{Oa^2} + \overline{Ob^2} + \overline{Oc^2} + \&c. + \overline{Pa^2} + \overline{Pb^2} + \overline{Pe^2} + \&c.$
 $= nr^2$. Consequently, when AB, BC, &c. are unequal among themselves, the sum of the squares, cubes, &c. of perpendiculars drawn from P and Q to lines touching the circle in the points A, B, C, &c. is not invariable.

$\overline{AP^2} + \overline{BP^2} + \overline{CP^2} + \&c. + \overline{AQ^2} + \overline{BQ^2} + \overline{CQ^2} + \&c.$ being $= 4nr^2$, whether AB, AC, &c. be equal or unequal, is invariable.

variable. But their 4th, 6th, 8th, &c. are not invariable, when AB, BC, &c. are unequal among themselves.

It is manifest, that when AB, BC, &c. are equal among themselves, whatever be the number of the points A, B, C, &c. or whatever be the part of the circumference they take in or extend to, the sum of the squares, cubes, &c. of perpendiculars drawn from P and Q to lines touching the circle in these points, is the same with the sum of the squares, cubes, &c. of perpendiculars drawn from P and Q to the sides of a regular circumscribing figure having the same number of sides as there are points, A, B, C, &c. Thus, if the number of the points be five, and these be comprehended in a semicircle, a quadrant, or any sector, the sum of the squares, cubes, and fourth powers of perpendiculars drawn from P and Q to lines touching the circle in these points, is the same with the sum of the squares, cubes, and fourth powers of perpendiculars drawn from P and Q to the sides of a regular pentagon circumscribing the circle. And so on.

PERPENDICULARS drawn from P, (fig. 2.), one extremity of the diameter PQ, to the sides of the figure of an uneven or odd number of sides circumscribing the circle, and touching it in the points A, B, C, D, E, &c. are respectively equal to perpendiculars drawn from Q, the other extremity of the diameter, to the sides of a circumscribing figure of double the number of sides, which touch the circle in the points H, I, K, L, G, &c. or $Hg = Bc$, $Ge = Aa$, $Lb = Ed$, $Kf = Db$, $Ii = Ck$, &c.; and perpendiculars drawn from Q to the sides of the figure of an odd number of sides, are respectively equal to perpendiculars drawn from P to the sides of a figure of double the number of sides, which touch the circle in the points H, I, K, L, G, &c. or $Df = Kb$, $Ci = Ik$, $Bg = Hc$, $Ae = Ga$, $Eb = Ld$, &c. Wherefore, the sum of the m powers of perpendiculars, drawn from P and Q to the sides of any circumscribing figure of an odd number of sides, is equal to half the sum of the m powers

of

of perpendiculars drawn from P and Q to the sides of a circumscribing figure of double the number of sides.

THUS, if the figure be a pentagon, we get

$$r + \overline{Oa^3} + r - \overline{Oa^3} = 2r^3 + 6r \times \overline{Oa^2}$$

$$r + \overline{Oc^3} + r - \overline{Oc^3} = 2r^3 + 6r \times \overline{Oc^2}$$

$$r + \overline{Ok^3} + r - \overline{Ok^3} = 2r^3 + 6r \times \overline{Ok^2}$$

$$r + \overline{Ob^3} + r - \overline{Ob^3} = 2r^3 + 6r \times \overline{Ob^2}$$

$$r + \overline{Od^3} + r - \overline{Od^3} = 2r^3 + 6r \times \overline{Od^2}$$

$$\text{Sum} = 10r^3 + 6r \times \overline{Oa^2} + \overline{Oc^2} + \overline{Ok^2} + \overline{Ob^2} + \overline{Od^2} = 25r^3 = 10 \times \frac{5r^3}{2}$$

WHEN the diameter PQ bisects the arcs BK, DH, or is perpendicular to one of the diameters passing through a point of contact, Ok, Oi vanish, and it is then demonstrated exactly in the same way as in figures of an even number of sides, that the sum of the cubes of perpendiculars drawn from either P or Q is

$\frac{5^n}{2} \times r^3$, and consequently that the sum of the cubes of those

drawn from P, is equal to the sum of those drawn from Q. But let the figure be a pentagon, and let the diameter AG be perpendicular to any side in the point of contact A. Draw Cm, Bn perpendicular to AG. Then Gm is equal to each of the perpendiculars drawn from G to the sides touching the circle in the points C and D; and Am to each of the perpendiculars drawn from A to the same sides; Gn is equal to each of the perpendiculars drawn from G to the sides touching the circle in the points B, E, and An, to each of the perpendiculars drawn from A to the same sides. Wherefore 2Gm + 2Gn + GA (2r) = 2An + 2Am, or r - Om + r + On + r = An + Am = r - On

$$+ r + Om, \text{ and } r = 2Om - 2On. \text{ Therefore } Om = \frac{r + 2On}{2},$$

$$r - Om = \frac{r - 2On}{2} = Gm, \text{ and } r + Om = \frac{3r + 2On}{2} = Am.$$

Consequently we have $2 \times \overline{Om^3} = \frac{27r^3 + 54r^2 \times On + 36r \times \overline{On^2} + 8 \times \overline{On^3}}{4},$

and $2 \times \overline{r - On^3} = 2r^3 - 6r^2 \times On + 6r \times \overline{On^2} - 2 \times \overline{On^3},$ and

these added together give $\frac{35r^3 + 30r^2 \times On + 60r \times \overline{On^2}}{4}.$ In

like manner, $2 \times \overline{r - Om^3} = \frac{r^3 - 6r^2 \times On + 12r \times \overline{On^2} - 8 \times \overline{On^3}}{4},$

and $2 \times \overline{r + On^3} = 2r^3 + 6r^2 \times On + 6r \times \overline{On^2} + 2 \times \overline{On^3},$ and

these added together give $\frac{9r^3 + 18r^2 \times On + 36r \times \overline{On^2}}{4},$ to

which, if $\overline{GA^3} = 8r^3,$ the cube of the perpendicular to the side touching the circle in the point A, be added, we get

$$\frac{41r^3 + 18r^2 \times On + 36r \times \overline{On^2}}{4}.$$

BUT the sum of the cubes of perpendiculars, drawn from A and G to the sides of the pentagon is $25r^3,$ as has been demonstrated, when PQ coincides with AG. Wherefore

$$\frac{76r^3 + 48r^2 \times On + 96r \times \overline{On^2}}{4} \text{ or } 19r^3 + 12r^2 \times On + 24r$$

$$\times \overline{On^2} = 25r^3 \text{ and } 4r \times \overline{On^2} + 2r^2 \times On = r^3. \text{ Now, if for}$$

this value of $r^3,$ there be substituted r^3 in $\frac{41r^3 + 18r^2 \times On + 36r \times \overline{On^2}}{4},$

we

we get $\frac{41r^3+9r^3}{4} = \frac{25r^3}{2}$; and if r^3 be substituted for its equal in

$$\frac{35r^3 + 30r^2 \times On + 60r \times On^2}{4}, \text{ we get } \frac{35r^3 + 15r^3}{4} = \frac{25r^3}{2}.$$

Wherefore the sum of the cubes of perpendiculars drawn from the point G to the sides of the pentagon, is equal to the sum of the cubes of perpendiculars drawn from the point A to the same.

$$\text{SINCE } 2 \times \overline{Om^3} + 2 \times \overline{On^3} = 4r^3 + 3r^2 \times 2\overline{Om} - 2\overline{On} \\ + 3r \times 2 \times \overline{Om^2} + 2 \times \overline{On^2} + 2 \times \overline{Om^3} - 2 \times \overline{On^3} = \frac{25r^3}{2}, \text{ and}$$

$$2 \times \overline{Om^2} + \overline{On^2} = \frac{3r^2}{2}, \text{ we have } 3r^2 \times 2 \times \overline{Om} - 2 \times \overline{On} +$$

$$2 \times \overline{Om^3} - \overline{On^3} = 4r^3. \text{ But } 2\overline{Om} - 2\overline{On} = r; \text{ therefore}$$

$$2 \times \overline{Om^3} - \overline{On^3} = r^3, \text{ or } \overline{Om^3} - \overline{On^3} = \frac{r^3}{2}.$$

IF P, instead of bisecting the arc BK, be any point between B and K, the sum of the cubes of perpendiculars drawn from it to the sides of the circumscribing pentagon, is equal to the sum of the cubes of perpendiculars drawn from Q to the same. For since $Oc + Oa + Ok = Ob + Od$ and $Oc - Ob, Od - Oa$ and Ok , begin together, and become maxima together, $Oc - Ob$ has to Ok a given ratio. Let that be the ratio of m to 1. Then $Oc - Ob = m \times Ok$, and $Od - Oa = Oc - Ob + Ok = \overline{m+1} \times Ok$. $Oc = Ob + m \times Ok, Oa = Od - \overline{m+1} \times Ok$.

$$\overline{Oc^3} = \overline{Ob^3} + 3m \times \overline{Ob^2} \times Ok + 3m^2 \times Ob \times \overline{Ok^2} + m^3 \times$$

$$\overline{Ok^3}. \quad \overline{Oa^3} = \overline{Od^3} - 3 \times \overline{m+1} \times \overline{Od^2} \times Ok + 3 \times \overline{m+1} \times Od \times$$

$\overline{Ok}^2 - \overline{Ok}^3$. Wherefore $\overline{Oc}^3 + \overline{Oa}^3 + \overline{Ok}^3 = \overline{Ob}^3 + \overline{Od}^3 + 3m \times$
 $\overline{Ob}^2 \times Ok - 3 \times \overline{m+1} \times \overline{Od}^2 \times Ok + 3m^2 \times Ob \times \overline{Ok}^2 + 3 \times$
 $\overline{m+1} \times Od \times \overline{Ok}^2 + \overline{Ok}^3$. Now, let this be $= \overline{Ob}^3 + \overline{Od}^3 \pm$
 V^3 . Then $3m \times \overline{Ob}^2 - 3 \times \overline{m+1} \times \overline{Od}^2 + 3m^2 \times Ob \times Ok +$
 $3 \times \overline{m+1} \times Od \times Ok + \overline{Ok}^3 = \pm \overline{Ok}^3$, and $m \times \overline{Ob}^2 = \overline{m+1}$
 $\times \overline{Od}^2 \pm \frac{V^3}{3}$, when $Ok = 0$. But $m \times \overline{Ob}^2 = \overline{m+1} \times \overline{Od}^2$;

therefore $V = 0$. For when $Ok = 0$, Ob is the sine of 72° , and
 Od the sine of 36° . When Ok is a maximum, it is the sine of
 18° , Oc is $= r$, Ob is the cosine of 36° , and $Oc - Ob$ the
 versed sine of 36° . Wherefore, $\overline{m+1} : m = \overline{Ob}^2 : \overline{Od}^2 =$ ver-
 sed sine of $36^\circ +$ sine of $18^\circ : \text{versed sine of } 36^\circ$.

LET BD (Pl. II. fig. 3) $= BH =$ side of an inscribed pentagon;
 bisect BD in F , and draw OFC , AC , BC and DH . Then, since the
 angle FOB is 36° , CF is the versed sine of 36° , OG is the sine of
 18° . But since the triangles CFB , DGO , are similar $OG : CF = DG :$
 $FB = DH : DB$, and $OG + CF : CF = DH + DB : DB = \overline{DH}^2 :$
 $\overline{DB}^2 = \overline{DG}^2 ; \overline{FB}^2 =$ square of the sine of $72^\circ : \text{square of the}$
 sine of 36° . For when DH is cut in extreme and mean ratio,
 the greater part is equal to the side of the pentagon.

DH is cut in extreme and mean ratio in the point L , and LH
 $= BD$; the triangle CDP is similar to the triangle DOB ; and
 the triangle MDN to the triangle BOC .

THIS demonstration, however, was unnecessary. For if the
 sum of the cubes of perpendiculars drawn from P to the sides of
 the pentagon, be equal to the sum of the cubes of perpendiculars
 drawn

drawn from Q to the same, both when Ok is $= o$, and when it is a maximum, this equality must exist whatever be the magnitude of Ok between these limits.

AND in a similar manner is it demonstrated, that the sum of the cubes of perpendiculars drawn from P to the sides of any other regular figure of an odd number of sides circumscribing the circle, is equal to the sum of the cubes of perpendiculars drawn from Q to the same. For if Om , &c. or such parts of perpendiculars drawn from A to the sides of any regular circumscribing figure of an odd number, n , of sides as lie between O and G, be denoted by A, B, C, &c.; and On , &c. or such parts of perpendiculars drawn from G to the same as lie between

O and A, be denoted by a, b, c , &c. $A + B + C + \&c.$ to $\frac{n-1}{4}$

terms, $-a - b - \&c.$ to $\frac{n-1}{4}$ terms, $= \frac{r}{2}$, if $n-1$ be a multiple

of 2 by an even number. Also $A^2 + B^2 + C^2 + \&c.$ to $\frac{n-1}{4}$ terms,

$+ a^2 + b^2 + c^2 + \&c.$ to $\frac{n-1}{4}$ terms, $= \frac{n-2}{4} \times r^2$; and $A^3 + B^3$

$+ C^3 + \&c.$ to $\frac{n-1}{4}$ terms, $- a^3 - b^3 - c^3 - \&c.$ to $\frac{n-1}{4}$ terms,

$= \frac{r^3}{2}$. But if $n-1$ be a multiple of 2 by an odd number, $A +$

$B + C + \&c.$ to $\frac{n+1}{4}$ terms, $- a - b - \&c.$ to $\frac{n-3}{4}$ terms,

$= \frac{r}{2}$; $A^2 + B^2 + C^2 + \&c.$ to $\frac{n+1}{4}$ terms, $+ a^2 + b^2 + \&c.$ to

$\frac{n-3}{4}$ terms $= \frac{n-2}{4} \times r^2$, and $A^3 + B^3 + C^3 + \&c.$ to $\frac{n+1}{4}$

terms

terms, $-a^3 - b^3 - \&c.$ to $\frac{n-3}{4}$ terms, $= \frac{r^3}{2}$. Thus, in the heptagon $A + B - a = \frac{r}{2}$, $A^2 + B^2 + a^2 = \frac{5r^2}{4}$; and $A^3 + B^3 - a^3 = \frac{r^3}{2}$. In the enneagon $A + B - a - b = \frac{r}{2}$, $A^2 + B^2 + a^2 + b^2 = \frac{7r^2}{4}$ and $A^3 + B^3 - a^3 - b^3 = \frac{r^3}{2}$, and so on. But in the enneagon, A is the cosine of 20° , or the sine of 70° , B is the sine of $30^\circ = \frac{r}{2}$, a is the sine of 10° , and b the sine of 50° . Wherefore the sine of $70^\circ =$ sine of $10^\circ +$ the sine of 50° ; the square of the sine of $70^\circ +$ square of the sine of $10^\circ +$ square of the sine of $50^\circ = \frac{3r^2}{2}$; and the cube of the sine of $70^\circ -$ cube of the sine of $10^\circ -$ cube of the sine of $50^\circ = \frac{3r^3}{8}$, viz. thrice the cube of half the radius. And so on.

$$\overline{r - Oc^4} = r^4 - 4r^3 \times Oc + 6r^2 \times \overline{Oc^2} - 4r \times \overline{Oc^3} + \overline{Oc^4},$$

$$\overline{r - Oa^4} = r^4 - 4r^3 \times Oa + 6r^2 \times \overline{Oa^2} - 4r \times \overline{Oa^3} + \overline{Oa^4},$$

$$\overline{r - Ok^4} = r^4 - 4r^3 \times Ok + 6r^2 \times \overline{Ok^2} - 4r \times \overline{Ok^3} + \overline{Ok^4},$$

$$\overline{r + Ob^4} = r^4 + 4r^3 \times Ob + 6r^2 \times \overline{Ob^2} + 4r \times \overline{Ob^3} + \overline{Ob^4},$$

$$\overline{r + Od^4} = r^4 + 4r^3 \times Od + 6r^2 \times \overline{Od^2} + 4r \times \overline{Od^3} + \overline{Od^4},$$

$$\text{Sum} = \overline{5r^4 + 6r^2 \times \overline{Oc^2} + \overline{Oa^2} + \overline{Ok^2} + \overline{Ob^2} + \overline{Od^2} + \overline{Oc^4} + \overline{Oa^4} + \overline{Ob^4} + \overline{Od^4}}.$$

BUT

BUT since $5r$ (= sum of the perpendiculars drawn from P or Q to the sides of the pentagon) = $\frac{\overline{AP}^2 + \overline{BP}^2 + \overline{CP}^2 + \overline{DP}^2 + \overline{EP}^2}{2r}$
 = $\frac{\overline{AQ}^2 + \overline{BQ}^2 + \overline{CQ}^2 + \overline{DQ}^2 + \overline{EQ}^2}{2r}$; and since the sum of the

squares of perpendiculars drawn from P to the sides of the pentagon, has been demonstrated equal to the sum of the squares of

perpendiculars from Q to the same, $\frac{\overline{AP}^4 + \overline{BP}^4 + \overline{CP}^4 + \overline{DP}^4 + \overline{EP}^4}{4r^2}$

$$= \frac{\overline{AQ}^4 + \overline{BQ}^4 + \overline{CQ}^4 + \overline{DQ}^4 + \overline{EQ}^4}{4r^2} = \frac{15r^2}{2}. \text{ And as the cir-}$$

cumference of the circle, which has PO for its diameter, is divided into five equal parts, in the points a, b, c, d, k , $\overline{Oc}^2 + \overline{Oa}^2$

$$+ \overline{Ok}^2 + \overline{Ob}^2 + \overline{Od}^2 = r \times \frac{5 \times OP}{2} = \frac{5r^2}{2}; \text{ and } \overline{Oc}^4 + \overline{Oa}^4 + \overline{Ok}^4$$

$$+ \overline{Ob}^4 + \overline{Od}^4 = 4 \times \frac{OP^3}{4} \times \frac{15}{2} \times \frac{OP}{4} = \frac{15r^4}{8}. \text{ Wherefore,}$$

$$5r^4 + 6r^2 \times \overline{Oc}^2 + \overline{Oa}^2 + \overline{Ok}^2 + \overline{Ob}^2 + \overline{Od}^2 + \overline{Oc}^4 + \overline{Oa}^4 + \overline{Ok}^4$$

$$+ \overline{Ob}^4 + \overline{Od}^4 = \frac{40r^4}{8} + \frac{120r^4}{8} + \frac{15r^4}{8} = \frac{175}{8} \times r^4 = \frac{35 \times 5}{8}$$

$\times r^4$ = half the sum of the fourth powers of perpendiculars drawn from both P and Q to the sides of the pentagon.

IN the same way is it demonstrated, that the sum of the fourth powers of perpendiculars drawn from P to the sides of any regular circumscribing figure of an odd number, n , of sides, is equal to the sum of the fourth powers of perpendiculars drawn from

Q

Q to the same, $= \frac{35^n}{8} \times r^4 = n \times \frac{1 \cdot 3 \cdot 5 \cdot 7}{1 \cdot 2 \cdot 3 \cdot 4} \times r^4$. When P coincides with B, O c is $= r$, and $A^4 + B^4 + C^4 + \&c.$ to $\frac{n-1}{4}$ terms, $+ a^4 + b^4 + c^4 + \&c.$ to $\frac{n-1}{4}$ terms, (when $n-1$ is a multiple of 2 by an even number) is $= \frac{3^{n-8}}{16} \times r^4$; and $A^4 + B^4 + C^4 + \&c.$ to $\frac{n+1}{4}$ terms, $+ a^4 + b^4 + \&c.$ to $\frac{n-3}{4}$ terms, (when $n-1$ is a multiple of 2 by an odd number) is $= \frac{3^{n-8}}{16} \times r^4$.

IN like manner is it demonstrated, that the sum of the fifth powers of perpendiculars drawn from P to the sides of any regular circumscribing figure of a greater number n of sides than 5, is equal to the sum of the fifth powers of perpendiculars drawn from Q to the same; and that $A^5 + B^5 + C^5 + \&c.$ to $\frac{n-1}{4}$ terms, $- a^5 - b^5 - c^5 - \&c.$ to $\frac{n-1}{4}$ terms, (when $n-1$ is a multiple of 2 by an even number) is $= \frac{r^5}{2}$, and $A^5 + B^5 + C^5 + \&c.$ to $\frac{n+1}{4}$ terms $- a^5 - b^5 - \&c.$ to $\frac{n-3}{4}$ terms, (when $n-1$ is a multiple of 2 by an odd number) is $= \frac{r^5}{2}$.

A is the cofine of $\frac{180^\circ}{n}$, B is the cofine of $3 \times \frac{180^\circ}{n}$, C is the cofine of $5 \times \frac{180^\circ}{n}$, and so on; and when $n - 1$ is a multiple of 2 by an even number, the last of the terms A, B, C, &c. is the cofine of $\frac{n-3}{2} \times \frac{180^\circ}{n}$, and a , the first of the terms a, b, c , &c. is the cofine of $\frac{n+1}{2} \times \frac{180^\circ}{n}$; b , the second, is the cofine of $\frac{n+5}{2} \times \frac{180^\circ}{n}$; c , the third, is the cofine of $\frac{n+9}{2} \times \frac{180^\circ}{n}$; and the last of the terms a, b, c , &c. is the cofine of $\frac{2n-4}{2} \times \frac{180^\circ}{n}$, or of $n-2 \times \frac{180^\circ}{n}$. But when $n - 1$ is a multiple of 2 by an odd number, the last of the terms A, B, C, &c. is the cofine of $\frac{n-1}{2} \times \frac{180^\circ}{n}$; the first of the terms a, b , &c. is the cofine of $\frac{n+3}{2} \times \frac{180^\circ}{n}$ and the last of the terms a, b , &c. is the cofine of $n-2 \times \frac{180^\circ}{n}$. Universally, if m be any odd number less than n , we have $A^m + B^m + C^m + \&c.$ to $\frac{n-1}{4}$ terms, $-a^m - b^m - c^m - \&c.$ to $\frac{n-1}{4}$ terms, $= \frac{r^m}{2}$, when $n - 1$ is a multiple of 2 by an even number; and $A^m + B^m + C^m + \&c.$ to $\frac{n+1}{4}$ terms, $-a^m - b^m - \&c.$ to $\frac{n-3}{4}$ terms, $= \frac{r^m}{2}$, when

VOL. VI.—P. I. G $n-1$

$n-1$ is a multiple of 2 by an odd number. Thus, in the enneagon, or figure of nine sides, A is the cosine of 20° or the sine of 70° , B is the cosine of 60° or the sine of 30° , a is the cosine of 100° or the sine of 10° , and b is the cosine of 140° or the sine of 50° , and $A^n - a^n - b^n = \frac{2^{n-1} - 1}{2^{n/2}} \times r^n$. And if p be

any even number less than n , $A^p + B^p + C^p + \&c.$ to $\frac{n-1}{4}$ terms or $\frac{n+1}{4}$ terms $+ a^p + b^p + c^p + \&c.$ to $\frac{n-1}{4}$ terms, or $\frac{n-3}{4}$ terms, (according as $n-1$ is a multiple of 2 by an even

or odd number) is $= n \times \frac{1 \cdot 3 \cdot 5 \cdot 7 \dots p-1}{1 \cdot 2 \cdot 3 \cdot 4 \dots \frac{p}{2}} \times \frac{r^p - r^{\frac{p+2}{2}}}{2^{\frac{p+2}{2}}}$. Con-

sequently, $\overline{A^p + a^p + A^n - a^n} + \overline{B^p + b^p + B^n - b^n} + \&c.$ to $\frac{n-1}{4}$ terms, is $= n \times \frac{1 \cdot 3 \cdot 5 \cdot 7 \dots p-1}{1 \cdot 2 \cdot 3 \cdot 4 \dots \frac{p}{2}} \times \frac{r^p}{2^{\frac{p+2}{2}}} - \frac{r^p}{2} + \frac{r^n}{2} =$

$\frac{\frac{p+2}{2} \cdot \frac{p+6}{2} \cdot \frac{p+10}{2} \dots p-1}{2 \cdot 4 \cdot 6 \dots \frac{p}{2}} \times \frac{r^p}{2^{\frac{p+2}{2}}} - \frac{r^p}{2} + \frac{r^n}{2}$ (when

$n-1$ is a multiple of 2 by an even number) $= \frac{\frac{p+2}{2} \cdot \frac{p+6}{2} \cdot \frac{p+10}{2} \dots \text{to } \frac{2p-2}{2}}{2 \cdot 4 \cdot 6 \dots \text{to } \frac{p}{2}} \times \frac{1}{2^{\frac{p+2}{2}}}$, when $r=1$;

and when $n-1$ is a multiple of 2 by an odd number $\overline{A^p + A^n} + \overline{B^p + B^n} + \overline{C^p + C^n} + \&c.$ to $\frac{n+1}{4}$ terms, $+ \overline{a^p - a^n} + \overline{b^p - b^n}$

$b^p - b^m + c^p - c^m + \&c.$ to $\frac{n-3}{4}$ terms, is equal to $n \times$

$$\frac{1 \cdot 3 \cdot 5 \cdot 7 \dots \text{to } p-1}{1 \cdot 2 \cdot 3 \cdot 4 \dots \text{to } \frac{p}{2}} \times \frac{r^p}{2^{\frac{p+2}{2}}} - \frac{r^p}{2} + \frac{r^m}{2}, \text{ which when } r=1$$

$$\text{is } = n \times \frac{\frac{p+2}{2} \cdot \frac{p+6}{2} \cdot \frac{p+10}{2} \dots \text{to } \frac{2p-2}{2}}{2 \cdot 4 \cdot 6 \dots \text{to } \frac{p}{2}} \times \frac{1}{2^{\frac{p+2}{2}}} = n \times$$

$$\frac{\frac{p+2}{2} \cdot \frac{p+6}{2} \dots \text{to } \frac{2p-2}{2}}{2 \cdot 4 \dots \text{to } \frac{p}{2}} \times \frac{1}{2^{\frac{p+2}{2}}}. \text{ Hence the summation of}$$

an endless variety of series, of which the terms are powers of the sines and cosines of angles; and though they do not consist of an infinite number of terms, they may consist of any number of

terms whatever, since $\frac{n-1}{4}$ may be equal to any given number

as well as $\frac{n+1}{4}$ and $\frac{n-3}{4}$. The expression $n \times \frac{1 \cdot 3 \cdot 5 \cdot 7 \dots \text{to } p-1}{1 \cdot 2 \cdot 3 \cdot 4 \dots \text{to } \frac{p}{2}}$

$$\times \frac{1}{2^{\frac{p+2}{2}}} \text{ is } = n \times \frac{\frac{p+2}{2} \cdot \frac{p+6}{2} \dots \text{to } \frac{2p-2}{2}}{2 \cdot 4 \dots \text{to } \frac{p}{2}} \times \frac{1}{2^{\frac{p+2}{2}}}, \text{ when}$$

$\frac{p}{2}$ is equal to an even number, or p is a multiple of 2 by an even

number. But when $\frac{p}{2}$ is an odd number, it is equal to $n \times$

$$\frac{\frac{p+4}{2} \cdot \frac{p+8}{2} \dots \text{to } \frac{2p-2}{2}}{2 \cdot 4 \dots \text{to } \frac{p-2}{2}} \times \frac{1}{2^{\frac{p+2}{2}}}, \text{ which must then be used.}$$

THE sums of these series, however, vary with the variations in the magnitude of r . For when $r = 2, 3, 4, \&c.$ — $\frac{r^p}{2}$ +

$\frac{r^{2p}}{2}$ does not vanish, and $\frac{r^p}{2^{\frac{p+2}{2}}}$ becomes respectively $2^{\frac{p}{2}-1}, \frac{3^p}{2^{\frac{p+2}{2}}},$

$$\frac{4^p}{2^{\frac{p+2}{2}}} \&c.$$

$$\overline{A^m - a^m} + \overline{B^m - b^m} + \overline{C^m - c^m} + \&c. \text{ to } \frac{n-1}{4} \text{ terms} =$$

$\frac{r^n}{2}$, when $n-1$ is a multiple of 2 by an even number, and the

sum of the series is constant or invariable when m is given, let

the number of the terms $\frac{n-1}{4}$ be great or small. This series,

when n is infinitely great, or $n-1$ has to 4 a ratio greater than any given or assignable ratio, may be considered as infinite.

$$\frac{\overline{A^m - a^m} + \overline{B^m - b^m} + \overline{C^m - c^m} + \&c. \text{ to } \frac{n-1}{4} \text{ terms.}}{\overline{A - a} + \overline{B - b} + \overline{C - c} + \&c. \text{ to } \frac{n-1}{4} \text{ terms}} = \frac{r^m}{2} \div \frac{r}{2} = r^{m-1}.$$

$$\overline{A^m - a^m} + \overline{B^m - b^m} + \&c. \text{ to } \frac{n-1}{4} \text{ terms; } \times \overline{A - a} + \overline{B - b}$$

$$+ \&c. \text{ to } \frac{n-1}{4} \text{ terms,} = \frac{r^{m+1}}{4}. \overline{A^m + A - a^m - a} + \overline{B^m + B - b^m - b}$$

$$+ \&c. \text{ to } \frac{n-1}{4} \text{ terms} = \frac{r^m + r}{2} = 1, \text{ when } r = 1.$$

$$\overline{A^m - A - a^m - a} + \overline{B^m - B - b^m - b} + \&c. \text{ to } \frac{n-1}{4} \text{ terms,}$$

$$= \frac{r^m - r}{2} = 0, \text{ when } r = 1.$$

It may not be unacceptable to geometers to see the foregoing conclusions in regard to regular figures circumscribed about and inscribed in a circle, derived by making use of one point only; instead of two, either in or not in the circumference, which is easily effected in the following manner.

LET the sides of any regular figure of an even number of sides touch the circle BRETQOLS (Pl. II. fig. 4.) in the points B, R, E, T, C, Q, L, S, and let DN, DH, DM, DV, be perpendiculars from the point D to the diameters joining the points of contact; and from the points of contact let chords be drawn to any point A in the circumference.

If GE, or the radius of the circle, be denoted by r , and A a , A b , A c , A d , be perpendiculars to the diameters joining the points of contact, aC , aB , T b , S b , L c , E c , Q d , d R , are respectively equal to the perpendiculars from the point A to the sides of the figure, and are also respectively equal to $\frac{AC^2}{2r}$, $\frac{AB^2}{2r}$,

$\frac{AT^2}{2r}$, $\frac{AS^2}{2r}$, $\frac{AL^2}{2r}$, $\frac{AE^2}{2r}$, $\frac{AQ^2}{2r}$, $\frac{AR^2}{2r}$. But if N denote the num-

ber of sides of the figure, the sum of the perpendiculars is = $N \times r$. Wherefore $\overline{AC} + \overline{AB} + \overline{AT} + \&c. = 2 N \times r^2$.

This is Prop. 4. Dr STEWART's Theor.

AGAIN, the sum of the squares of the two perpendiculars from A, parallel to BC, or $\overline{Ba} + \overline{aC} = 2r^2 + 2 \times \overline{Ga}$; and the

squares of the two perpendiculars from A parallel to LE, or $\overline{Ec} + \overline{cL} = 2r^2 + 2 \times \overline{Gc}$; T b + S b = $2r^2 + 2 \times \overline{Gb}$; also

$\overline{Rd} + \overline{dQ} = 2r^2 + 2 \times \overline{Gd}$. Wherefore the sum of the squares of the perpendiculars drawn from the point A to the

sides

sides of the figure, is $= N \times r^3 + 2 \times \overline{Ga^2} + \overline{Gb^2} + \overline{Gc^2} + \overline{Gd^2}$.

But since the angles $G a A$, $G b A$, $G c A$, $G d A$, are right ones, a circle passes through the points A, a, b, G, c, d having GA for its diameter. And because the angles CGT , QGC , LGQ are equal, this circle is equally divided by the points a, b, c, d . Consequently the squares of the chords drawn from these

points to the point A , are together $= N \times \frac{\overline{GA^2}}{4}$; that is, $\overline{Ac^2} (\overline{Ga^2})$

$$+ \overline{Aa^2} (\overline{Gc^2}) + \overline{Ad^2} (\overline{Gb^2}) + \overline{Ab^2} (\overline{Gd^2}) = N \times \frac{\overline{GA^2}}{4} =$$

$N \times \frac{r^2}{4}$. Wherefore the sum of the squares of the perpendiculars drawn from A to the sides of the figure, is $= N \times r^2 + 2N$

$\times \frac{r^2}{4} = N \times \frac{3r^2}{2}$. But the sum of the squares of these perpendiculars is $= \frac{\overline{AC^4}}{4r^2} + \frac{\overline{AB^4}}{4r^2} + \frac{\overline{AT^4}}{4r^2} + \frac{\overline{AS^4}}{4r^2} + \frac{\overline{AL^4}}{4r^2} + \frac{\overline{AE^4}}{4r^2} + \frac{\overline{AQ^4}}{4r^2}$

$$+ \frac{\overline{AR^4}}{4r^2}. \text{ Therefore } \overline{AC^4} + \overline{AB^4} +, \&c. = N \times 6r^4 = N \times 2r^2$$

$\times 3r^2 = \overline{AC^2} + \overline{AB^2} +, \&c. \times 3r^2$. Whence this proposition:

If a circle be divided into any even number of parts, and from the points of division chords be drawn to any point in the circumference, the sum of the fourth powers of these chords is equal to the sum of their squares, multiplied by thrice the square of radius.

WHEREFORE

$$\begin{aligned} \text{WHEREFORE } \overline{Aa^4} + \overline{Ab^4} + \overline{Ac^4} + \overline{Ad^4} &= \overline{Aa^2} + \overline{Ab^2} + \overline{Ac^2} + \overline{Ad^2} \\ \times \frac{3\overline{GA^2}}{4} &= N \times \frac{3r^4}{16}; \text{ and } \overline{DM^4} + \overline{DV^4} + \overline{DH^4} + \overline{DN^4} \\ &= \overline{DM^2} + \overline{DV^2} + \overline{DH^2} + \overline{DN^2} \times \frac{3 \times \overline{DG^2}}{4} = \frac{3 \times N}{16} \times \overline{DG^4} = \\ &\frac{6N}{2} \times \frac{\overline{DG^4}}{16}. \end{aligned}$$

Now, it is evident, that perpendiculars drawn from the point D to the sides of the figures, are respectively $r + DM$, $r - DM$, $r + DV$, $r - DV$, $r + DH$, $r - DH$, $r + DN$, $r - DN$.

$$\text{BUT } \overline{r + DM^2} + \overline{r - DM^2} = 2r^2 + 2 \times \overline{DM^2},$$

$$\overline{r + DV^2} + \overline{r - DV^2} = 2r^2 + 2 \times \overline{DV^2},$$

$$\overline{r + DH^2} + \overline{r - DH^2} = 2r^2 + 2 \times \overline{DH^2},$$

$$\overline{r + DN^2} + \overline{r - DN^2} = 2r^2 + 2 \times \overline{DN^2}.$$

WHEREFORE the sum of their squares is equal to $N \times r^2 + 2 \times \overline{DM^2} + \overline{DV^2} + \overline{DH^2} + \overline{DN^2} = N \times r^2 + N \times \frac{\overline{GD^2}}{2}$, since

the circle which passes through the points D, M, V, G, H, N, is equally divided by the points M, V, H, N. This is Prop. 5. of Dr STEWART'S Theorems.

$$\overline{r + DM^3} + \overline{r - DM^3} = 2r^3 + 6r \times \overline{DM^2},$$

$$\overline{r + DV^3} + \overline{r - DV^3} = 2r^3 + 6r \times \overline{DV^2},$$

$$\overline{r + DH^3} + \overline{r - DH^3} = 2r^3 + 6r \times \overline{DH^2},$$

$$\overline{r + DN^3} + \overline{r - DN^3} = 2r^3 + 6r \times \overline{DN^2}.$$

WHEREFORE,

WHEREFORE, the sum of the cubes of the perpendiculars, drawn from the point D to the sides of the figure, is $= N \times r^3 +$

$$6r \times \overline{DM^2 + DV^2 + DH^2 + DN^2} = N \times r^3 + 6r \times \frac{\overline{DG^2}}{4}$$

This is Prop. 23. STEWART'S Theor. When $DG = r$, the sum of the cubes of the perpendiculars is $= N \times \frac{5}{2} \times r^3 = N \times$

$\frac{1 \cdot 3 \cdot 5}{1 \cdot 2 \cdot 3} r^3$. This is Prop. 22. Dr STEWART'S Theor.

WHEN $DG = r$, or D coincides with A, the sum of the cubes of the perpendiculars is equal to $\frac{\overline{AC^6}}{8r^2} + \frac{\overline{AB^6}}{8r^3} + \frac{\overline{AT^6}}{8r^3} +$, &c.;

and, consequently, we get $\overline{AC^6} + \overline{AB^6} + \overline{AT^6} +$, &c. $= \frac{5 \cdot 8}{2}$

$$\times N \times r^6 = N \times 20r^6 = N \times \frac{1 \cdot 3 \cdot 5}{1 \cdot 2 \cdot 3} \cdot 2^3 r^6 = N \times 20 \times r^6 =$$

$$N \times 10r^4 \times \overline{AC^2 + AB^2 + AT^2} +, \text{ \&c.}$$

IF, therefore, the circumference of a circle be divided into an even number of equal parts, and from the points of division chords be drawn to any point in the circumference, the sum of the sixth powers of these chords is equal to the sum of their squares, multiplied by ten times the fourth power of radius.

$$\overline{r + DM^4} + \overline{r - DM^4} = 2r^4 + 12r^2 \times \overline{DM^2} + 2 \times \overline{DM^4},$$

$$\overline{r + DV^4} + \overline{r - DV^4} = 2r^4 + 12r^2 \times \overline{DV^2} + 2 \times \overline{DV^4},$$

$$\overline{r + DH^4} + \overline{r - DH^4} = 2r^4 + 12r^2 \times \overline{DH^2} + 2 \times \overline{DH^4},$$

$$\overline{r + DN^4} + \overline{r - DN^4} = 2r^4 + 12r^2 \times \overline{DN^2} + 2 \times \overline{DN^4}.$$

WHEREFORE

WHEREFORE, the sum of the fourth powers of the perpendiculars drawn from the point D to the sides of the figure, is = $N \times r^4 + N \times 3r^2 \times \overline{GD}^2 + N \times \frac{3}{8} \times \overline{GD}^4$; and eight times this

sum = $N \times 8r^4 + 24r^2 \cdot \overline{GD}^2 + 3 \cdot \overline{GD}^4$. This is Prop. 29. of Dr STEWART's Theorems.

WHEN $\overline{GD} = r$, the sum of these fourth powers is $N \times 4r^4 + \frac{3}{8}r^4 = N \times \frac{35}{8}r^4 = N \times \frac{1 \cdot 3 \cdot 5 \cdot 7}{1 \cdot 2 \cdot 3 \cdot 4} \times r^4$, which is Prop. 28. of Dr STEWART's Theorems.

AND since $\frac{\overline{AC}^8}{2^4 r^4} + \frac{\overline{AB}^8}{2^4 r^4} + \frac{\overline{AT}^8}{2^4 r^4} + \dots = N \times \frac{35 r^4}{8}$, we get

$\overline{AC}^8 + \overline{AB}^8 + \overline{AT}^8 + \dots = N \times \frac{35}{8} \cdot 2^4 r^8 = N \times \frac{1 \cdot 3 \cdot 5 \cdot 7}{1 \cdot 2 \cdot 3 \cdot 4} \times 2^4 r^8$.

AND by proceeding in this way, (the law of continuation being evident), we get Propositions 39, 40, 41, &c. of Dr STEWART's Theorems, since the powers of DM, DV, DH, DN, &c. however high, may always be expressed by those of DG and r . The same reasoning holds in all even powers, when the point D is without the figure, by taking the powers of DH, + r , &c. when DH, &c. is greater than than r , instead of the powers of $r \pm$ DH, &c.

LET any regular figure of an odd number of sides, (Pl. III. Fig. 5.), circumscribe the circle, and touch it in the points B, E, C, Q, L; and from any point D, let perpendiculars DP, DR, DS, DO, DT, be drawn to the sides of the figure; and DF, DM, DN, DH, DV, perpendiculars to the diameters passing through the points of contact:

VOL. VI.—P. I.

H

THEN

THEN, if radius be denoted by r , it is evident, that DP is $= r - GN$, $DR = r - GF$, $DS = r + GH$, $DO = r + GM$, and $DT = r + GV$; and calling N the number of the sides of the figure, the sum of the squares of these lines is $N \times r^2 + 2r \times \overline{GH} + \overline{GM} + \overline{GV} - \overline{GN} - \overline{GF} + \overline{GH}^2 + \overline{GM}^2 + \overline{GV}^2 + \overline{GN}^2 + \overline{GF}^2$. But since the angles HGN , NGM , MGF , FGV , are equal, and the angles at H , N , M , F , V , right ones, a circle, having its diameter $= GD$, passes through the points G , H , N , D , M , F , V , and its circumference is divided into equal parts at the points H , N , M , F , V . Wherefore $\overline{GH}^2 + \overline{GN}^2 + \overline{GM}^2 + \overline{GF}^2 + \overline{GV}^2 = 2 \times N \times \frac{\overline{GD}^2}{4} = N \times \frac{\overline{GD}^2}{2}$. But $\overline{DP}^2 + \overline{DR}^2 + \overline{DS}^2 + \overline{DO}^2 + \overline{DT}^2 = N \times r^2 + N \times \frac{\overline{GD}^2}{2}$. (STEWART'S Theor.

Prop. 5.). Therefore $2r \times \overline{GH} + \overline{GM} + \overline{GV} - \overline{GN} - \overline{GF} = 0$, or $\overline{GN} + \overline{GF} = \overline{GH} + \overline{GM} + \overline{GV}$. Whence this proposition: If, from any point, perpendiculars be drawn to the sides of any regular figure of an odd number of sides, circumscribing a circle, the sum of the parts by which those perpendiculars, which are greater than radius, exceed it, is equal to the sum of those parts by which the perpendiculars, which are less than radius, fall short of it. And this proposition is also true with regard to any regular figure, of which the number of its sides is a multiple of any odd number by 2, since the perpendiculars DF , DM , DN , DH , DV , &c. are the same both in number and magnitude, in any regular figure of an odd number of sides, and a regular figure of double the number of sides. Consequently, in a hexagon, one of the three perpendiculars drawn from any point D to the diameters joining the opposite points of contact, is equal

equal to the sum of the other two, and so on; and if, in the hexagon, the point D be taken in one of the three diameters, the perpendiculars drawn from it to the other two are equal.

$$\begin{aligned} \text{AGAIN, } \overline{DP}^3 + \overline{DR}^3 + \overline{DS}^3 + \overline{DO}^3 + \overline{DT}^3 &= N \times r^3 + 3r^2 \\ \times \overline{GH} + \overline{GM} + \overline{GV} - \overline{GN} - \overline{GF} + 3r \times \\ \overline{GH}^2 + \overline{GM}^2 + \overline{GV}^2 + \overline{GN}^2 + \overline{GF}^2 + \overline{GH}^3 + \overline{GM}^3 + \overline{GV}^3 - \\ \overline{GN}^3 - \overline{GF}^3 &= N \times r^3 + N \times 3r \cdot \frac{\overline{GD}^2}{2} + \overline{GH}^3 + \overline{GM}^3 + \\ \overline{GV}^3 - \overline{GN}^3 - \overline{GF}^3. \text{ But since } N \times r^3 + N \times 3r \times \frac{\overline{GD}^2}{2} &= \\ \overline{DP}^3 + \overline{DR}^3 + \overline{DS}^3 + \overline{DO}^3 + \overline{DT}^3 \cdot \overline{GH}^3 + \overline{GM}^3 + \overline{GV}^3 &= \\ \overline{GN}^3 + \overline{GF}^3. \end{aligned}$$

IF D be in a line perpendicular from G the centre, to a diameter drawn from any point of contact L, the odd chord GV vanishes, (V coinciding with G), and GN = GM, GH = GF; and the expression for the sum of the cubes of the perpendiculars, drawn from D to the sides of the circumscribing figure, is

$$\text{simply } N \times r^3 + N \times 3r \times \frac{\overline{GD}^2}{2}$$

IF the figure circumscribing the circle be a pentagon, a line drawn from G, bisecting the angle QGd nearer to G, is perpendicular to LG; also, if D be in the line Gd, the point M coincides with D, GN = GF, GH = GV, and GM coincides with GD, and twice the cube on GF or GN is equal to the three cubes on GD, GH, GV, or to the cube on GD with twice the cube on GH or GV; and the difference of the cubes on GF, GV, or on GN, GH,

is then equal to half the cube on GD, or $2 \overline{GF}^3 - 2 \overline{GV}^3 = \overline{GD}^3$.

HENCE an easy solution of this problem.

HAVING two equal right lines given, it is required to cut one of them into two parts, and the other into three parts; so that the cubes on the two parts, into which the one of these lines is cut, shall, together, be equal to the cubes on the three parts, into which the other is cut, taken together.

HENCE, also, an easy construction for this problem: On a given right line, to constitute a triangle, such that twice the difference of the cubes on the other two sides, shall be equal to the cube on the given line.

LET AC be the given line, (Pl. III. Fig. 6.). With A as radius, describe an arc AB. Take the angle ACB = 36° . Draw AG perpendicular to CB, and join AB. From A and C as centres, describe arcs with the radii $\frac{AB}{2}$, and CG, intersecting in the point F. Then CFA is the triangle required; and $2 \cdot \overline{CF}^3 - 2 \cdot \overline{AF}^3 = \overline{CA}^3$.

DEMONSTRATION.

SINCE the angle ACB is 36° , AB is the side of a decagon inscribed in the circle, which has AC for its radius; and CG is the perpendicular to the side of an inscribed pentagon. But it is

well known, that CG is = $\frac{AC + AB}{2}$, and $\overline{AC}^2 = \overline{AB}^2 +$

$AC \times AB$. Consequently $3 \overline{AC}^3 = 3 AC^2 \times AB + 3 AC \times \overline{AB}^2$;

add \overline{AC}^3 to both, and we have $4 \overline{AC}^3 = \overline{AC}^3 + 3 \overline{AC}^2 \times AB +$

$3 AC$

$$3 AC \times AB^2, \text{ and } \overline{AC^3} = \frac{\overline{AC^3} + 3\overline{AC^2} \times AB + 3 AC \times \overline{AB^2}}{4} =$$

$$\frac{AC + \overline{AB^3} - \overline{AB^3}}{8} \times 2 = 2 \times \overline{CG^3} - \overline{AF^3}. \text{ Thus, in any circle,}$$

the cube of radius is equal to twice the difference between the cubes on the perpendicular to the side of the inscribed pentagon, and half the side of the inscribed decagon.

PROPOSITION. Let any regular figure of an odd number of sides, be circumscribed about a circle, and let (*n*) be any odd number, less than the number of the sides of the figure; and from any point within the figure let perpendiculars be drawn to the sides of the circumscribing figure; then the sum of the (*n*) powers of the parts by which those perpendiculars, which are greater than radius, exceed it, is equal to the sum of the (*n*) powers of those parts by which the perpendiculars, which are less than radius, fall short of it.

HENCE these problems.

HAVING two equal given right lines, to cut one of them into two parts, and the other into three, so that the cubes on the two parts, into which one of them is cut, shall, together, be equal to the cubes on the three parts, into which the other is cut, taken together.

AND having two equal right lines given, to cut one of them into seven parts, and the other into eight, so that the cubes, the 5th powers, the 7th, 9th, 11th and 13th powers, of the seven parts, into which the one is cut, shall, together, be respectively equal to the cubes, the 5th, the 7th, the 9th, the 11th, and the 13th powers, of the eight parts, into which the other is cut.

THE first of these two problems is effected by a pentagon, inscribed in a circle; and the second, by a quindecagon inscribed.

If V be as much on the other side of the centre G , towards L , as it is towards C , the lines GN , GM , exchange their values or magnitudes, as also do the lines GH , GF ; and the perpendiculars to the sides of the circumscribing figure then become $r - GM$, $r - GH$, $r + GN$, $r + GF$, $r - GV$; and the sum of

their cubes $N \times r^3 + N \times 3r \cdot \frac{\overline{GD}^3}{2} + \overline{GN}^3 + \overline{GF}^3 - \overline{GM}^3 -$

$\overline{GH}^3 - \overline{GV}^3$; which added to $N \times r^3 + N \times 3r \cdot \frac{\overline{GD}^2}{2} + \overline{GM}^3$

$\overline{GH}^3 + \overline{GV}^3 - \overline{GN}^3 - \overline{GF}^3$, the sum of their cubes before found, and the aggregate divided by 2, gives $N \times r^3 + N \times 3r \cdot$

$\frac{\overline{GD}^2}{2}$, the sum of their cubes, when D is in the line drawn from

the centre G perpendicular to LG .

LET a circle, (Pl. III. Fig. 7.), be described on BC , with the centre G , and let BF be a square on the diameter BC ; draw EGD from E , through the centre G , to meet the circle in D , and join DF .

THEN, since $BG \times CS$, or $CG \times CS = \overline{GS}^2$, GC is cut in extreme and mean proportion in the point S , and GS is the side of a regular decagon, inscribed in the circle. And since the perpendicular from G to the side of a regular inscribed pentagon, is

$= \frac{BG + GS}{2}$, BS is twice that perpendicular. But $\frac{\overline{BG + GS}^3}{2}$,

or $\frac{r + \overline{GS}^3}{8} - \frac{\overline{GS}^3}{8} = \frac{r^3}{2}$. Consequently $\overline{BS}^3 - \overline{GS}^3$, or $r + \overline{GS}^3$

$- \overline{GS}^3 = 4r^3$. Therefore $3r^3 = 3r^2 \times GS + 3r \times \overline{GS}^2$, and

r^3

$r^3 = r^2 \times GS + r \times \overline{GS^2}$. But BS is cut in G, in the same manner as GC is cut in S. Wherefore, if another circle be described, with BS as radius, and a line be drawn from one of the angles of a square, described on the diameter, through the centre, to meet the circumference in a point, and if this point, and the other opposite angle of the square be joined, $2r + \overline{GS^3} - r^3$ will in like manner be $= 4 \times \overline{r + GS^3}$, or $4 \times \overline{BS^3}$, and $7r^3 + 12r^2 \cdot GS + 6r \cdot \overline{GS^2} + \overline{GS^3} = 4r^3 + 12r^2 \cdot GS + 12r \cdot \overline{GS^2} + 4 \cdot \overline{GS^3}$. Therefore $3r^3 = 6r \cdot \overline{GS^2} + 3 \overline{GS^3}$, and $r^3 = 2r \cdot \overline{GS^2} + \overline{GS^3} = r^2 \cdot GS + r \cdot \overline{GS^2}$. Therefore $2r \cdot GS + \overline{GS^2} = r^2 + r \cdot GS$, and $\overline{GS^2} + r \cdot GS = r^2$, and $\overline{GS^3} = r^2 \cdot GS - r \cdot \overline{GS^2}$.

If, therefore, from any point in the circumference of the circle BDC, perpendiculars be drawn to the sides of any regular figure circumscribed about it, the sum of their cubes being $= N \times \frac{5}{2} \cdot r^3$, (calling N the number of the sides of the figure), is $= N \times 5r \cdot \overline{GS^2} + N \times \frac{5}{2} \cdot \overline{GS^3}$; and twice the sum of the cubes of these perpendiculars is $N \times 5 \cdot \overline{GS^3} + N \times 10r \cdot \overline{GS^2}$; that is, equal to five times a multiple by the number of the sides of the figure of the cube on the side of an inscribed regular decagon, and ten times a multiple, by the same number of the solid, which has the square of the side of the inscribed decagon for its base, and radius for its altitude; and if the perpendiculars be drawn from any point P, within the circumscribed figure, that is, not in the circumference of the circle,

circle, twice the sum of their cubes will be equal to $2 N \times$

$$\overline{GS^3} + 2r \cdot \overline{GS^2} + 2 N \times 6r \times \frac{\overline{GP^2}}{4}; \text{ that is, equal to twice a}$$

multiple by the number of the sides of the figure of the cube on the side of the inscribed decagon, together with four times a multiple, by the same number of the solid which has the square of the side of the decagon for its base, and r for its altitude, together with thrice a multiple by the same number of the solid, which has the square of GP for its base, and r for its altitude.

IN like manner, may the sixth powers of lines drawn from the angles of any regular inscribed figure of a greater number of sides than three, to any point either in, or not in the circumference, be expressed in terms of the side of an inscribed decagon, since their sum is a multiple of the sum of the cubes of the perpendiculars, to the sides of the circumscribing figure, by $8 r^3$.

AGAIN, since $r + GS : r :: r : GS :: GS : r - GS$, we have $2r + GS : r + GS :: r + GS : r :: r : GS :: GS : r - GS$.

$$\text{WHEREFORE } \overline{3r + 2GS^3} - \overline{r + GS^3} = 4 \times \overline{2r + GS^3}, \text{ or}$$

$$26r^3 + 51r^2 \cdot GS + 33r \cdot \overline{GS^2} + 7\overline{GS^3} = 32r^3 + 48r^2 \cdot GS +$$

$$24r \cdot \overline{GS^2} + 4\overline{GS^3}, \text{ or } 3r^2 \cdot GS + 9r \cdot \overline{GS^2} + 3\overline{GS^3} = 6r^3, \text{ or}$$

$$r^2 \cdot GS + 3r \cdot \overline{GS^2} + \overline{GS^3} = 2r^3.$$

WHEREFORE, since four times the sum of the cubes of the perpendiculars drawn from any point in the circumference of the circle to the sides of any regular circumscribing figure, is $N \times 5 \times 2r^3$; four times the sum of these cubes is $= N \times$

$$\overline{5r^2 \cdot GS + 15r \cdot \overline{GS^2} + 5\overline{GS^3}} = 5 N \times \overline{r^2 \cdot GS + 3r \cdot \overline{GS^2} + \overline{GS^3}};$$

that

that is, equal to five times a multiple, by the number of the sides of the figure of the cube on the side of the inscribed decagon, together with fifteen times a multiple, by the same number, of the solid, which has the square on the side of the inscribed decagon as its base, and r for its altitude, together with five times a multiple, by the same number of the solid, which has r^2 for its base, and the side of the decagon for its altitude.

LET the circumference of a circle be divided into any number n of equal parts, and from any point in the circumference let chords be drawn to the points of division, and let $3m$ be any number less than n , the sum of the $2m$ powers of the lines which have respectively to $2r$ the diameter, the ratios which the cubes of the chords have respectively to $8r^3$, the cube of

the diameter, is equal to $n \times \frac{1 \cdot 3 \cdot 5 \cdot 7 \cdot \dots \cdot 6m - 1}{1 \cdot 2 \cdot 3 \cdot 4 \cdot \dots \cdot 3m} \times \frac{r^{2m}}{2^m}$.

LET the chords be denoted by A, B, C, D, &c. to n terms; and let $8r^3 : A^3 = 2r : a$, $8r^3 : B^3 = 2r : b$, $8r^3 : C^3 = 2r : c$,

$8r^3 : D^3 = 2r : d$, &c. Then $a = \frac{A^3}{4r^2}$, and $a^{2m} = \frac{A^{6m}}{2^{4m} r^{4m}}$ $b^{2m} =$

$\frac{B^{6m}}{2^{4m} r^{4m}}$, &c.; and $a^{2m} + b^{2m} + \dots$ to n terms, is $= \frac{A^{6m}}{2^{4m} r^{4m}}$

$+ \frac{B^{6m}}{2^{4m} r^{4m}} + \dots$ to n terms. If $p = 3m$, we have $a^{2m} +$

$b^{2m} + \dots = \frac{A^{2p}}{2^{p+m} r^{p+m}} + \frac{B^{2p}}{2^{p+m} r^{p+m}} + \dots$ But the sum of

the $2p$ powers of the chords A, B, &c. is $n \times \frac{1 \cdot 3 \cdot 5 \cdot 7 \cdot \dots \cdot 2^{p-1}}{1 \cdot 2 \cdot 3 \cdot 4 \cdot \dots \cdot p} 2^p r^{2p}$.

$$\text{Therefore } a^{2m} + b^{2m} + \&c. = n \times \frac{1 \cdot 3 \cdot 5 \cdot 7 \cdot \dots \cdot 2^{p-1}}{1 \cdot 2 \cdot 3 \cdot 4 \cdot \dots \cdot p} \times \frac{r^{2m-1}}{2^m} =$$

$$n \times \frac{1 \cdot 3 \cdot 5 \cdot 7 \cdot \dots \cdot 6^{m-1}}{1 \cdot 2 \cdot 3 \cdot 4 \cdot \dots \cdot 3^m} \times \frac{r^{2m}}{2^m}.$$

$$\text{If } m = 1, a^2 + b^2 + \&c. = n \times \frac{1 \cdot 3 \cdot 5}{1 \cdot 2 \cdot 3} \times \frac{r^2}{2} = \frac{5nr^2}{4}; \text{ and the}$$

diameter, (or $2r$) $\times \overline{a^2 + b^2 + c^2 + \&c.} =$ sum of the cubes of perpendiculars drawn from any point in the circumference, to the sides of a regular circumscribing polygon of n number of sides, and $a^2 + b^2 + \&c.$ is to the sum of the squares of these perpendiculars as 5 to 6; and if the perpendiculars to the sides of the polygon corresponding to the chords A, B, C, D, &c. and drawn from the same point in the circumference that these chords are drawn from, be denoted by P, Q, R, S, &c. $a + b +$

$$c + \&c. = \frac{A \times P}{2r} + \frac{B \times Q}{2r} + \frac{C \times R}{2r} + \frac{D \times S}{2r} + \&c. \quad 2^m r^m \times$$

$$\overline{a^{2m} + b^{2m} + c^{2m} + \&c.} = P^{3m} + Q^{3m} + R^{3m} + \&c. = \text{the sum}$$

$$\text{of the } 3^m \text{ powers of these perpendiculars, } = n \times \frac{1 \cdot 3 \cdot 5 \cdot 7 \cdot \dots \cdot 6^{m-1}}{1 \cdot 2 \cdot 3 \cdot 4 \cdot \dots \cdot 3^m}$$

$$\times r^{3m}.$$

THEOREM Φ . From any point C, (Pl. III. Fig. 8.), let the chord CA be drawn; let GAF be a tangent to the circle at A; and let AD be perpendicular to the diameter BC, and CF, BG to GF. The right line which has to BC ($2r$), the ratio of \overline{AC}^3 to \overline{BC}^3 , or the triplicate ratio of the chord of the arc AC, to the diameter, is $\frac{AC \times CF}{BC}$, or $\frac{AC \times CD}{BC} =$ a fourth proportional to the diameter, the chord and the perpendicular drawn from one extremity of the

the chord to the tangent to the circle at the other extremity, or a fourth proportional to the diameter, the chord and versed sine of the arc AC.

FOR, the angle CAF = the angle ABC = the angle CAD.

Therefore CD = CF, and AD = AF. But $CD = \frac{\overline{AC}^2}{BC}$. Conse-

quently $\frac{AC \times CD}{BC} = \frac{\overline{AC}^3}{BC^2}$, which has to BC the ratio of \overline{AC}^3

to \overline{BC}^3 . Q. E. D.

COR. 1. BD = perpendicular BG; GF = the chord AE of double the arc AC = twice the sine of the arc AC.

COR. 2. $\frac{AB \times BG}{BC}$, or $\frac{AB \times BD}{BC}$, has to BC, the ratio of \overline{AB}^3 to \overline{BC}^3 .

COR. 3. $\overline{CF}^3 = \frac{\overline{AC}^6}{\overline{BC}^3}$, $\overline{BG}^3 = \frac{\overline{AB}^5}{\overline{BC}^3}$, $\overline{CF}^3 = \frac{\overline{AC}^2 \times \overline{CD}^2}{\overline{BC}^2} \times$
 $BC = \frac{\overline{AC}^2 \times \overline{CF}^2 \times BC}{\overline{BC}^2}$, and $\overline{BG}^3 = \frac{\overline{AB}^2 \times \overline{BD}^2}{\overline{BC}^2} \times BC =$

$\frac{\overline{AB}^2 \times \overline{BG}^2}{\overline{BC}^2} \times BC$; and the lines, which have to BC the ratios of

$\overline{AC}^3 : \overline{BC}^3$; and $\overline{AB}^3 : \overline{BC}^3$ are to each other as AC × CD to AB × BD, or as AC × CF : AB × BG.

SEE Fig. 1. and Theorem Φ . Since the part of the tangent at the point A, that would be intercepted between perpendiculars drawn to it from P and Q, is equal to $2 Pa$, or $2 Qc$, the part of the tangent at the point B, that would be intercepted between perpendiculars drawn to it from P and Q, is $= 2 Pe$, or $2 Qf$; and the part of the tangent at C, that would be intercepted between perpendiculars drawn to it from P and Q, is $= 2 Pb$, or $2 Qd$, we have (when AB, BC, &c. are equal, or when the diameters passing through A, B, C, &c. make equal angles with one another at the centre O) the sum of the squares of these parts of the tangents, (calling n the number of the points of contact), $= n \times \frac{1}{1} \cdot 2 r^2$; the sum of their fourth powers

$= n \times \frac{1 \cdot 3}{1 \cdot 2} \times 2^2 r^4$; and the sum of the $2 m$ powers of these

parts (m being any integer less than n) $= n \times \frac{1 \cdot 3 \cdot 5 \dots 2 m - 1}{1 \cdot 2 \cdot 3 \dots m}$

$\times 2_m r^{2m}$ (r being the radius OP or OQ) = the sum of the $2 m$ powers of the chords drawn from either P or Q, at right angles to the diameters passing through A, B, C, &c. = the sum of the $2 m$ powers of chords, drawn to any point in the circumference from the angles of a regular inscribed figure of n number of sides, or from the points where a regular inscribed figure of n number of sides, touches the circle, = the sum of the $2 m$ powers of perpendiculars, drawn from P or Q to n number of right lines passing through Q or P, and intersecting each other at equal angles. And the sum of the $2 m$ powers of the halves of these parts of the tangents, or of the parts intercepted between the points of contact and perpendiculars drawn from either P or Q to the sides of the equal sided figure circumscribing the circle, or segment, is

$= n \times \frac{1 \cdot 3 \cdot 5 \dots 2 m - 1}{1 \cdot 2 \cdot 3 \dots m 2^m} \times r^{2m}$ = the sum of the $2 m$ powers of

the

the fines of the angles formed at the centre O, by OP or OQ; and the diameters passing through the points of contact to the radius

OP or OQ; that is, = $\overline{Pa}^{2m} + \overline{Pe}^{2m} + \overline{Pb}^{2m} +$, &c. or $\overline{Qc}^{2m} +$

$\overline{Qf}^{2m} + \overline{Qd}^{2m} +$, &c. = the sum of the $2m$ powers of perpendiculars drawn from any point in the circumference of a circle described from P as a centre, with PO as radius to n number of right lines, intersecting each other in P, and making all the angles equal, = the sum of the m powers of the rectangles $Aa \times aG$, $Be \times er$, $Cb \times bB$, &c.; or of the rectangles $Gc \times cA$, $rf \times fB$, $bd \times dC$, &c. when the regular figure circumscribing the circle has an odd number of sides; but equal to twice the sum of the $2m$ powers of said fines, or to twice the sum of the m powers of said rectangles, when the regular figure circumscribing the circle has an even number of sides, since the number of the diameters drawn through the opposite points of contact, and making equal angles with each other, at their intersection in the centre O, is only half the number of the points of contact or sides of the figure. But these rectangles are respectively equal

to $\overline{r-Oa} \times \overline{r+Oa}$, $\overline{r-Oe} \times \overline{r+Oe}$, $\overline{r-Ob} \times \overline{r+Ob}$, &c.

or $r^2 - \overline{Oa}^2$, $r^2 - \overline{Oe}^2$, $r^2 - \overline{Ob}^2$, &c.; and the sum of their m^{th}

powers is $n r^{2m} - \frac{m}{1} \cdot r^{2m-2} \times \overline{Oa}^2 + \overline{Oe}^2 + \overline{Ob}^2 +$, &c. to n terms,

$+ \frac{m}{1} \cdot \frac{m-1}{2} \cdot r^{2m-4} \times \overline{Oa}^4 + \overline{Oe}^4 + \overline{Ob}^4 +$, &c. to n terms $+$, &c.

&c. $+ \overline{Oa}^{2m} + \overline{Oe}^{2m} + \overline{Ob}^{2m} +$, &c. to (n) terms, or to

$-\overline{Oa}^{2m} - \overline{Oe}^{2m} - \overline{Ob}^{2m} -$, &c. to (n) terms, according as m

is even or odd.

150

151

152

153

154

155

156

157

158

159

160

161

162

163

164

165

166

167

168

169

170

171

172

173

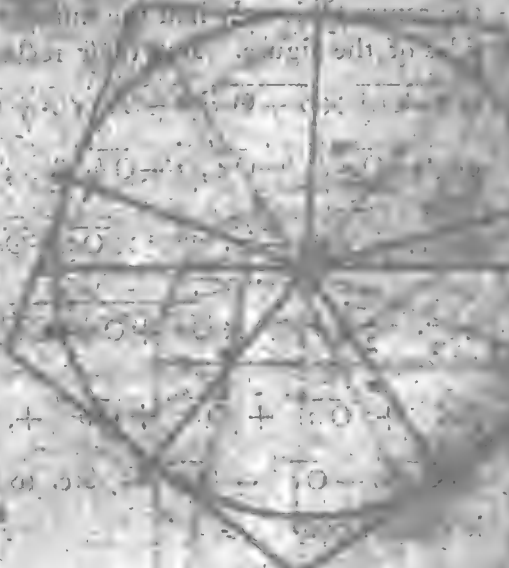
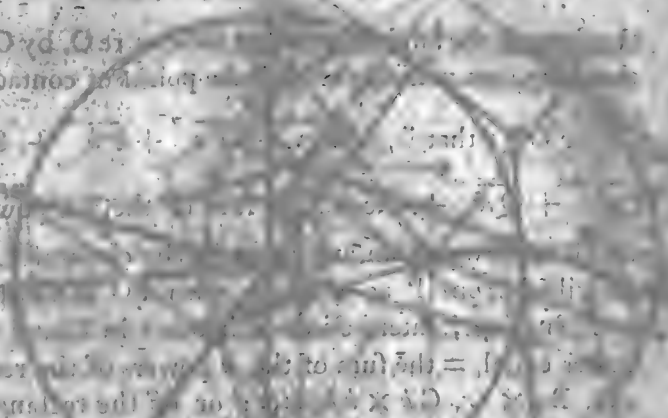
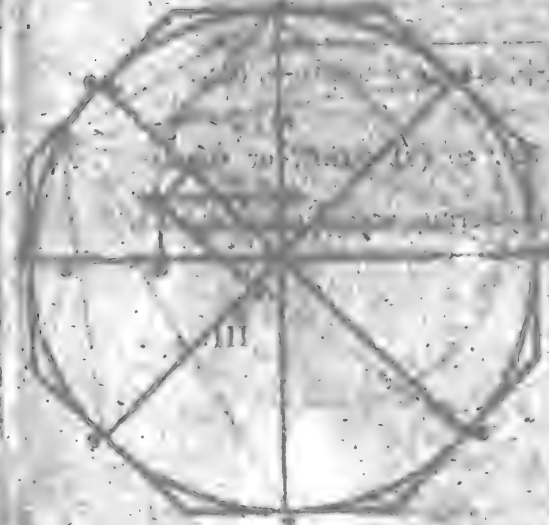
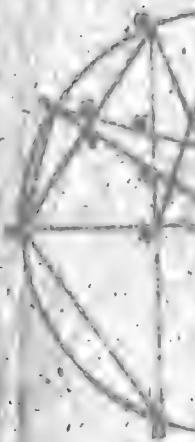

PLATE II.

Fig. 1.

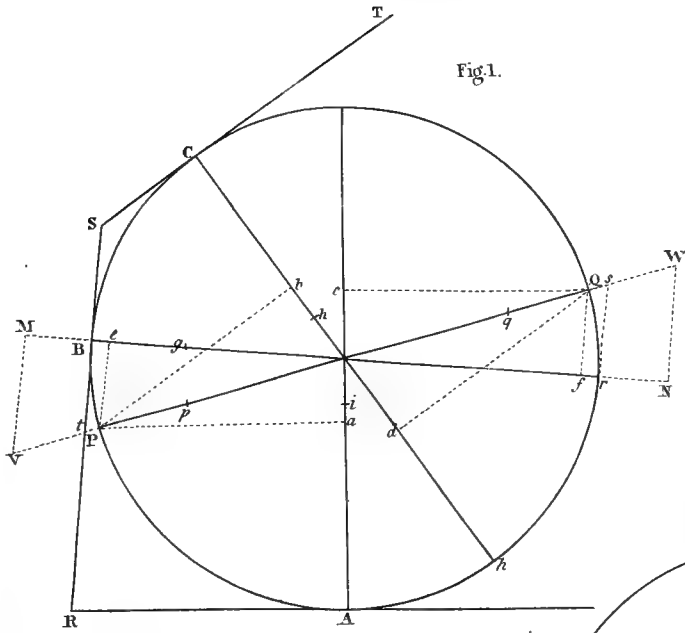

Fig. 2.

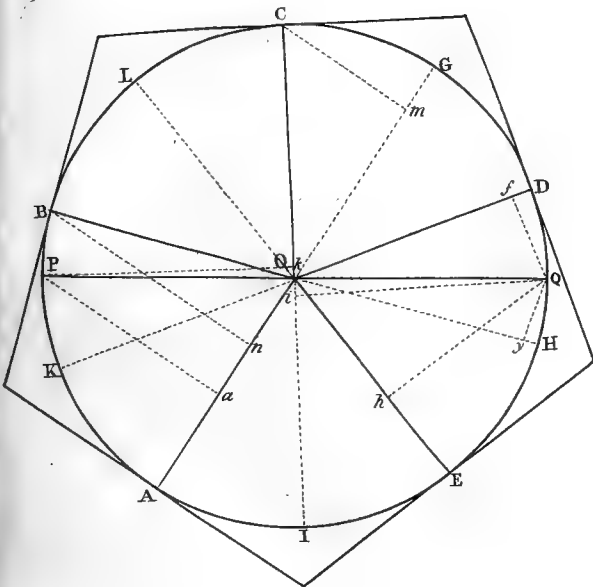

Fig. 3.

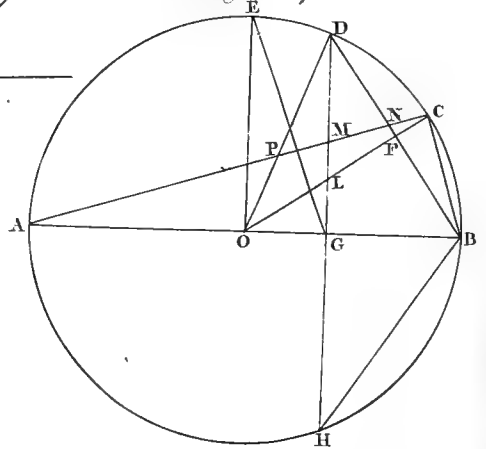

Fig. 4.

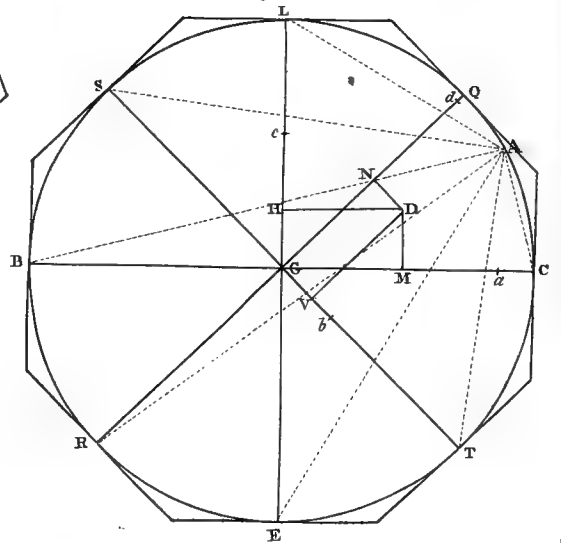



Fig. 5.

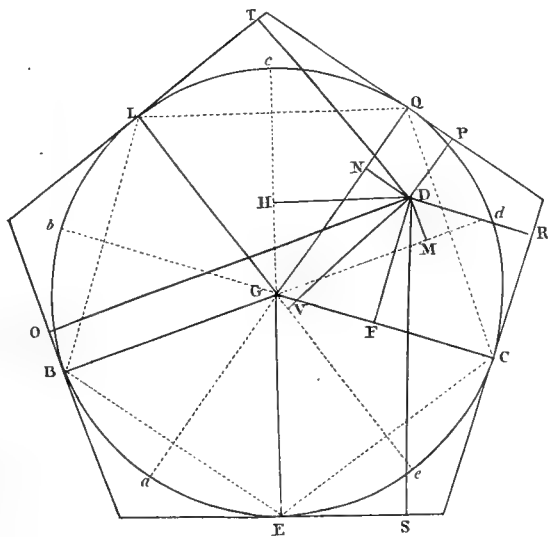

Fig. 6.

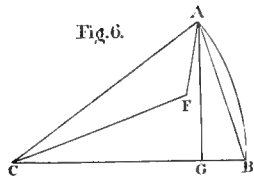

Fig. 7.

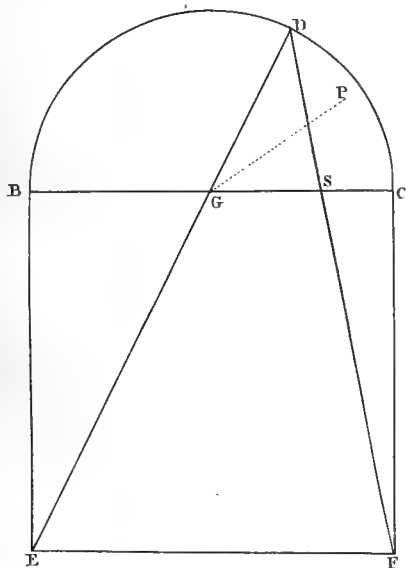
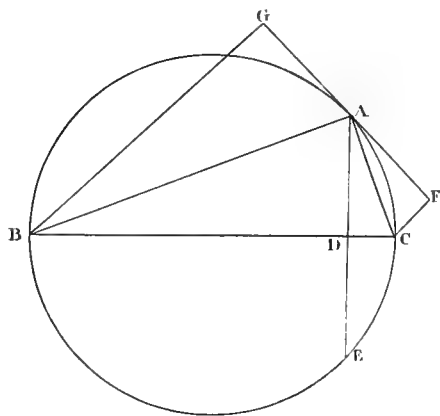

Fig. 8.





III. ACCOUNT of a SERIES of EXPERIMENTS, *shewing the EFFECTS of COMPRESSION in modifying the ACTION of HEAT.*
By Sir JAMES HALL, Bart. F. R. S. EDIN.

[Read June 3. 1805.]

I.

Ancient Revolutions of the Mineral Kingdom.—Vain attempts to explain them.—Dependence of Geology on Chemistry.—Importance of the Carbonate of Lime.—Dr BLACK's discovery of Carbonic Acid, subverted the former theories depending on Fire, but gave birth to that of Dr HUTTON.—Progress of the Author's Ideas with regard to that Theory.—Experiments with Heat and Compression, suggested to Dr HUTTON in 1790.—Undertaken by the Author in 1798.—Speculations on which his hopes of success were founded.

WHOOEVER has attended to the structure of Rocks and Mountains, must be convinced, that our Globe has not always existed in its present state; but that every part of its mass, so far at least as our observations reach, has been agitated and subverted by the most violent revolutions.

FACTS leading to such striking conclusions, however imperfectly observed, could not fail to awaken curiosity, and give rise to a desire of tracing the history, and of investigating the causes, of such stupendous events; and various attempts were made in this way, but with little success; for while discoveries
of

of the utmost importance and accuracy were made in Astronomy and Natural Philosophy, the systems produced by the Geologists were so fanciful and puerile, as scarcely to deserve a serious refutation.

ONE principal cause of this failure, seems to have lain in the very imperfect state of Chemistry, which has only of late years begun to deserve the name of a science. While Chemistry was in its infancy, it was impossible that Geology should make any progress; since several of the most important circumstances to be accounted for by this latter science, are admitted on all hands to depend upon principles of the former. The consolidation of loose sand into strata of solid rock; the crystalline arrangement of substances accompanying those strata, and blended with them in various modes, are circumstances of a chemical nature, which all those who have attempted to frame theories of the earth have endeavoured by chemical reasonings to reconcile to their hypotheses.

FIRE and WATER, the only agents in nature by which stony substances are produced, under our observation, were employed by contending sects of geologists, to explain all the phenomena of the mineral kingdom.

BUT the known properties of Water, are quite repugnant to the belief of its universal influence, since a very great proportion of the substances under consideration are insoluble, or nearly so, in that fluid; and since, if they were all extremely soluble, the quantity of water which is known to exist, or that could possibly exist in our planet, would be far too small to accomplish the office assigned to it in the Neptunian theory*. On the other hand, the known properties of Fire are no less inadequate to the purpose; for, various substances which frequently occur in the mineral kingdom, seem, by their presence, to preclude

* *Illustrations of the Huttonian Theory*, by Mr Professor PLAYFAIR, 430.

clude its supposed agency; since experiment shews, that, in our fires, they are totally changed or destroyed.

UNDER such circumstances, the advocates of either element were enabled, very successfully, to refute the opinions of their adversaries, though they could but feebly defend their own: and, owing perhaps to this mutual power of attack, and for want of any alternative to which the opinions of men could lean, both systems maintained a certain degree of credit; and writers on geology indulged themselves, with a sort of impunity, in a style of unphilosophical reasoning, which would not have been tolerated in other sciences.

OF all mineral substances, the *Carbonate of Lime* is unquestionably the most important in a general view. As limestone or marble, it constitutes a very considerable part of the solid mass of many countries; and, in the form of veins and nodules of spar, pervades every species of stone. Its history is thus interwoven in such a manner with that of the mineral kingdom at large, that the fate of any geological theory must very much depend upon its successful application to the various conditions of this substance. But, till Dr BLACK, by his discovery of Carbonic Acid, explained the chemical nature of the carbonate, no rational theory could be formed, of the chemical revolutions which it has undoubtedly undergone.

THIS discovery was, in the first instance, hostile to the supposed action of fire; for the decomposition of limestone by fire in every common kiln being thus proved, it seemed absurd to ascribe to that same agent the formation of limestone, or of any mass containing it.

THE contemplation of this difficulty led Dr HUTTON to view the action of fire in a manner peculiar to himself, and thus to form a geological theory, by which, in my opinion, he has furnished the world with the true solution of one of the most inte-

resting problems that has ever engaged the attention of men of science.

HE supposed,

I. THAT Heat has acted, at some remote period, on all rocks.

II. THAT during the action of heat, all these rocks (even such as now appear at the surface) lay covered by a superincumbent mass, of great weight and strength.

III. THAT in consequence of the combined action of Heat and Pressure, effects were produced different from those of heat on common occasions; in particular, that the carbonate of lime was reduced to a state of fusion, more or less complete, without any calcination.

THE essential and characteristic principle of his theory is thus comprised in the word *Compression*; and by one bold hypothesis, founded on this principle, he undertook to meet all the objections to the action of fire, and to account for those circumstances in which minerals are found to differ from the usual products of our furnaces.

THIS system, however, involves so many suppositions, apparently in contradiction to common experience, which meet us on the very threshold, that most men have hitherto been deterred from the investigation of its principles, and only a few individuals have justly appreciated its merits. It was long before I belonged to the latter class; for I must own, that, on reading Dr HUTTON's first geological publication, I was induced to reject his system entirely, and should probably have continued still to do so, with the great majority of the world, but for my habits of intimacy with the author; the vivacity and perspicuity of whose conversation, formed a striking contrast to the obscurity

security of his writings. I was induced by that charm, and by the numerous original facts which his system had led him to observe, to listen to his arguments, in favour of opinions which I then looked upon as visionary. I thus derived from his conversation, the same advantage which the world has lately done from the publication of Mr PLAYFAIR's *Illustrations*; and, experienced the same influence which is now exerted by that work, on the minds of our most eminent men of science.

AFTER three years of almost daily warfare with Dr HUTTON, on the subject of his theory, I began to view his fundamental principles with less and less repugnance. There is a period, I believe, in all scientific investigations, when the conjectures of genius cease to appear extravagant; and when we balance the fertility of a principle, in explaining the phenomena of nature, against its improbability as an hypothesis: The partial view which we then obtain of truth, is perhaps the most attractive of any, and most powerfully stimulates the exertions of an active mind. The mist which obscured some objects dissipates by degree, and allows them to appear in their true colours; at the same time, a distant prospect opens to our view, of scenes unsuspected before.

ENTERING now seriously into the train of reasoning followed by Dr HUTTON, I conceived that the chemical effects ascribed by him to compression, ought, in the first place, to be investigated; for, unless some good reason were given us for believing that heat would be modified by pressure, in the manner alleged, it would avail us little to know that they had acted together. He rested his belief of this influence on analogy; and on the satisfactory solution of all the phenomena, furnished by this supposition. It occurred to me, however, that this principle was susceptible of being established in a direct manner by experiment, and I urged him to make the attempt; but he always rejected this proposal, on account of

the immensity of the natural agents, whose operations he supposed to lie far beyond the reach of our imitation; and he seemed to imagine, that any such attempt must undoubtedly fail, and thus throw discredit on opinions already sufficiently established, as he conceived, on other principles. I was far, however, from being convinced by these arguments; for, without being able to prove that any artificial compression to which we could expose the carbonate, would effectually prevent its calcination in our fires, I maintained, that we had as little proof of the contrary, and that the application of a moderate force might possibly perform all that was hypothetically assumed in the Huttonian Theory. On the other hand, I considered myself as bound, in practice, to pay deference to his opinion, in a field which he had already so nobly occupied, and abstained, during the remainder of his life, from the prosecution of some experiments with compression, which I had begun in 1790.

IN 1798, I resumed the subject with eagerness, being still of opinion, that the chemical law which forms the basis of the Huttonian Theory, ought, in the first place, to be investigated experimentally; all my subsequent reflections and observations having tended to confirm my idea of the importance of this pursuit, without in any degree rendering me more apprehensive as to the result.

IN the arrangement of the following paper, I shall first confine myself to the investigation of the chemical effects of Heat and Compression, reserving to the concluding part, the application of my results to Geology. I shall, then, appeal to the volcanoes, and shall endeavour to vindicate the laws of action assumed in the Huttonian Theory, by shewing, that lavas, previous to their eruptions, are subject to similar laws; and that the volcanoes, by their subterranean and submarine exertions,

tions, must produce, in our times, results similar to those ascribed, in that Theory, to the former action of fire.

IN comparing the Huttonian operations with those of the volcanoes, I shall avail myself of some facts, brought to light in the course of the following investigations; by which a precise limit is assigned to the intensity of the heat, and to the force of compression, required to fulfil the conditions of Dr HUTTON'S hypothesis: For, according to him, the power of those agents was very great, but quite indefinite; it was therefore impossible to compare their supposed effects in any precise manner with the phenomena of nature.

My attention was almost exclusively confined to the Carbonate of Lime, about which I reasoned as follows: The carbonic acid, when uncombined with any other substance, exists naturally in a gaseous form, at the common temperature of our atmosphere; but when in union with lime, its volatility is repressed, in that same temperature, by the chemical force of the earthy substance, which retains it in a solid form. When the temperature is raised to a full red-heat, the acid acquires a volatility by which that force is overcome, it escapes from the lime, and assumes its gaseous form. It is evident, that were the attractive force of the lime increased, or the volatility of the acid diminished by any means, the compound would be enabled to bear a higher heat without decomposition, than it can in the present state of things. Now, pressure must produce an effect of this kind; for when a mechanical force opposes the expansion of the acid, its volatility must, to a certain degree, be diminished. Under pressure, then, the carbonate may be expected to remain unchanged in a heat, by which, in the open air, it would have been calcined. But experiment alone can teach us, what compressing force is requisite to enable it to resist any given elevation of temperature; and what is to be the result of such an operation. Some of the compounds of lime with acids
are

are fusible, others refractory; the carbonate, when constrained by pressure to endure a proper heat, may be as fusible as the muriate.

ONE circumstance, derived from the Huttonian Theory, induced me to hope, that the carbonate was easily fusible, and indicated a precise point, under which that fusion ought to be expected. Nothing is more common than to meet with nodules of calcareous spar inclosed in whinstone; and we suppose, according to the Huttonian Theory, that the whin and the spar had been liquid together; the two fluids keeping separate, like oil and water. It is natural, at the junction of these two, to look for indications of their relative fusibilities; and we find, accordingly, that the termination of the spar is generally globular and smooth; which seems to prove, that, when the whin became solid, the spar was still in a liquid state; for had the spar congealed first, the tendency which it shews, on all occasions of freedom, to shoot out into prominent crystals, would have made it dart into the liquid whin, according to the peculiar forms of its crystallization; as has happened with the various substances contained in whin, much more refractory than itself, namely, augite, felspar, &c.; all of which having congealed in the liquid whin, have assumed their peculiar forms with perfect regularity. From this I concluded, that when the whin congealed, which must have happened about 28° or 30° of WEDGWOOD, the spar was still liquid. I therefore expected, if I could compel the carbonate to bear a heat of 28° without decomposition, that it would enter into fusion. The sequel will shew, that this conjecture was not without foundation.

I SHALL now enter upon the description of those experiments, the result of which I had the honour to lay before this Society on the 30th of August last (1804); fully aware how difficult it is, in giving an account of above five hundred experiments, all tending to one point, but differing much from each other in various

ous

ous particulars, to steer between the opposite faults of prolixity and barrenness. My object shall be to describe, as shortly as possible, all the methods followed, so as to enable any chemist to repeat the experiments; and to dwell particularly on such circumstances only, as seem to lead to conclusions of importance.

THE result being already known, I consider the account I am about to give of the execution of these experiments, as addressed to those who take a particular interest in the progress of chemical operations: in the eyes of such gentlemen, I trust, that none of the details into which I must enter, will appear superfluous.

II.

Principle of execution upon which the following Experiments were conducted.—Experiments with Gun-Barrels filled with baked Clay, and welded at the muzzle.—Method with the Fusible Metal.—Remarkable effects of its expansion.—Necessity of introducing Air.—Results obtained.

WHEN I first undertook to make experiments with heat acting under compression, I employed myself in contriving various devices of screws, of bolts, and of lids, so adjusted, I hoped, as to confine all elastic substances; and perhaps some of them might have answered. But I laid aside all such devices, in favour of one which occurred to me in January 1798; which, by its simplicity, was of easy application in all cases, and accomplished all that could be done by any device, since it secured perfect strength and tightness to the utmost that the vessels employed could bear, whether formed of metallic or earthy substance. The device depends upon
the

the following general view: If we take a hollow tube or barrel (AD, fig. 1.) closed at one end, and open at the other, of one foot or more in length; it is evident, that by introducing one end into a furnace, we can apply to it as great heat as art can produce, while the other end is kept cool, or, if necessary, exposed to extreme cold. If, then, the substance which we mean to subject to the combined action of heat and pressure, be introduced into the breech or closed end of the barrel (CD), and if the middle part be filled with some refractory substance, leaving a small empty space at the muzzle (AB), we can apply heat to the muzzle, while the breech containing the subject of experiment, is kept cool, and thus close the barrel by any of the numerous modes which heat affords, from the welding of iron to the melting of sealing-wax. Things being then reversed, and the breech put into the furnace, a heat of any required intensity may be applied to the subject of experiment, now in a state of constraint.

My first application of this scheme was carried on with a common gun-barrel, cut off at the touch-hole, and welded very strongly at the breech by means of a plug of iron. Into it I introduced the carbonate, previously rammed into a cartridge of paper or pasteboard, in order to protect it from the iron, by which, in some former trials, the subject of experiment had been contaminated throughout during the action of heat. I then rammed the rest of the barrel full of pounded clay, previously baked in a strong heat, and I had the muzzle closed like the breech, by a plug of iron welded upon it in a common forge; the rest of the barrel being kept cold during this operation, by means of wet cloths. The breech of the barrel was then introduced horizontally into a common muffle, heated to about 25° of WEDGWOOD. To the muzzle a rope was fixed, in such a manner, that the barrel could be withdrawn without

out danger from an explosion*. I likewise, about this time, closed the muzzle of the barrel, by means of a plug, fixed by solder only; which method had this peculiar advantage, that I could shut and open the barrel, without having recourse to a workman. In these trials, though many barrels yielded to the expansive force, others resisted it, and afforded some results that were in the highest degree encouraging, and even satisfactory, could they have been obtained with certainty on repetition of the process. In many of them, chalk, or common limestone previously pulverised, was agglutinated into a stony mass, which required a smart blow of a hammer to break it, and felt under the knife like a common limestone; at the same time, the substance, when thrown into nitric acid, dissolved entirely with violent effervescence.

IN one of these experiments, owing to the action of heat on the cartridge of paper, the baked clay, which had been used to fill the barrel, was stained black throughout, to the distance of two-thirds of the length of the barrel from its breech. This circumstance is of importance, by shewing, that though all is tight at the muzzle, a protrusion may take place along the barrel, greatly to the detriment of complete

* ON one occasion, the importance of this precaution was strongly felt. Having inadvertently introduced a considerable quantity of moisture into a welded barrel, an explosion took place, before the heat had risen to redness, by which, part of the barrel was spread out to a flat plate, and the furnace was blown to pieces. DR KENNEDY, who happened to be present on this occasion, observed, that notwithstanding this accident, the time might come when we should employ water in these experiments to assist the force of compression. I have since made great use of this valuable suggestion: but he scarcely lived, alas! to see its application; for my first success in this way, took place during his last illness.—I have been exposed to no risk in any other experiment with iron barrels; matters being so arranged, that the strain against them has only commenced in a red heat, in which the metal has been so far softened, as to yield by laceration like a piece of leather.

plete compression: and, at the same time, it illustrates what has happened occasionally in nature, where the bituminous matter seems to have been driven by superior local heat, from one part of a coaly bed, though retained in others, under the same compression. The bitumen so driven off being found, in other cases, to pervade and tinge beds of slate and of sandstone.

I WAS employed in this pursuit in spring 1800, when an event of importance interrupted my experiments for about a year. But I resumed them in March 1801, with many new plans of execution, and with considerable addition to my apparatus.

IN the course of my first trials, the following mode of execution had occurred to me, which I now began to put in practice. It is well known to chemists, that a certain composition of different metals *, produces a substance so fusible, as to melt in the heat of boiling-water. I conceived that great advantage, both in point of accuracy and dispatch, might be gained in these experiments, by substituting this metal for the baked clay above mentioned: That after introducing the carbonate into the breech of the barrel, the fusible metal, in a liquid state, might be poured in, so as to fill the barrel to its brim: That when the metal had cooled and become solid, the breech might, as before, be introduced into a muffle, and exposed to any required heat, while the muzzle was carefully kept cold. In this manner, no part of the fusible metal being melted, but what lay at the breech, the rest, continuing in a solid state, would effectually confine the carbonic acid: That after the action of strong heat had ceased, and after all had been allowed to cool completely, the fusible metal might be removed entirely from the barrel, by means of a heat little above that of boiling water, and far too low to occasion any decomposition of the

* Eight parts of bismuth, five of lead, and three of tin.

the carbonate by calcination, though acting upon it in freedom; and then, that the subject of experiment might, as before, be taken out of the barrel.

THIS scheme, with various modifications and additions, which practice has suggested, forms the basis of most of the following methods.

IN the first trial, a striking phenomenon occurred, which gave rise to the most important of these modifications. Having filled a gun-barrel with the fusible metal, without any carbonate; and having placed the breech in a muffle, I was surpris'd to see, as the heat approached to redness, the liquid metal exuding through the iron in innumerable minute drops, dispersed all round the barrel. As the heat advanced, this exudation increased, till at last the metal flow'd out in continued streams, and the barrel was quite destroyed. On several occasions of the same kind, the fusible metal, being forced through some very minute aperture in the barrel, spouted from it to the distance of several yards, depositing upon any substance oppos'd to the stream, a beautiful assemblage of fine wire, exactly in the form of wool. I immediately understood, that the phenomenon was produced by the superior expansion of the liquid over the solid metal, in consequence of which, the fusible metal was driven through the iron as water was driven through silver* by mechanical percussion in the Florentine experiment. It occurred to me, that this might be prevented by confining along with the fusible metal a small quantity of air, which, by yielding a little to the expansion of the liquid, would save the barrel. This re-

L 2 medy

* *Essays of Natural Experiments made in the Academie del Cimento*, translated by WALLER, London, 1684, page 117. The same in MUSSCHENBROEK's Latin translation, Lugd. Bat. 1731, p. 63.

medy was found to answer completely, and was applied, in all the experiments made at this time*.

I NOW proposed, in order to keep the carbonate clean, to inclose it in a small vessel; and to obviate the difficulty of removing the result at the conclusion of the experiment, I further proposed to connect that vessel with an iron ramrod, longer than the barrel, by which it could be introduced or withdrawn at pleasure.

A SMALL tube of glass †, or of Raumur's porcelain, about a quarter of an inch in diameter, and one or two inches in length, (fig. 2. A) was half filled with pounded carbonate of lime, rammed as hard as possible; the other half of the tube being

* I found it a matter of much difficulty to ascertain the proper quantity of air which ought to be thus inclosed. When the quantity was too great, the result was injured by diminution of elasticity, as I shall have occasion fully to shew hereafter. When too small, or when, by any accident, the whole of this included air was allowed to escape, the barrel was destroyed.

I hoped to ascertain the bulk of air necessary to give liberty to the expansion of the liquid metal, by measuring the actual quantity expelled by known heats from an open barrel filled with it. But I was surpris'd to find, that the quantity thus discharged, exceeded in bulk that of the air which, in the same heats, I had confin'd along with the carbonate and fusible metal in many successful experiments. As the expansion of the liquid does not seem capable of sensible diminution by an opposing force, this fact can only be accounted for by a distention of the barrel. In these experiments, then, the expansive force of the carbonic acid, of the included air, and of the fusible metal, acted in combination against the barrel, and were yielded to in part by the distention of the barrel, and by the condensation of the included air. My object was to increase the force of this mutual action, by diminishing the quantity of air, and by other devices to be mentioned hereafter. Where so many forces were concerned, the laws of whose variations were unknown, much precision could not be expected, nor is it wonderful, that in attempting to carry the compressing force to the utmost, I should have destroyed barrels innumerable.

† I have since constantly used tubes of common porcelain, finding glass much too fusible for this purpose.

being filled with pounded filix, or with whatever occurred as most likely to prevent the intrusion of the fusible metal in its liquid and penetrating state. This tube so filled, was placed in a frame or cradle of iron (*d f k b*, figs. 3, 4, 5, and 6,) fixed to the end (*m*) of a ram-rod (*m n*). The cradle was from six to three inches in length, and as much in diameter as a gun-barrel would admit with ease. It was composed of two circular plates of iron, (*d e f g* and *b i k l*, seen edge-wise in the figures,) placed at right-angles to the ram-rod, one of these plates (*d e f b*) being fixed to it by the centre (*m*). These plates were connected together by four ribs or flattened wires of iron (*d b*, *e i*, *f k*, and *g l*,) which formed the cradle into which the tube (A), containing the carbonate, was introduced by thrusting the adjacent ribs asunder. Along with the tube just mentioned, was introduced another tube (B), of iron or porcelain, filled only with air. Likewise, in the cradle, a pyrometer* piece (C) was placed in contact with (A) the tube containing the carbonate. These articles generally occupied

the

* THE pyrometer-pieces used in these experiments were made under my own eye. Necessity compelled me to undertake this laborious and difficult work, in which I have already so far succeeded as to obtain a set of pieces, which, though far from complete, answer my purpose tolerably well. I had lately an opportunity of comparing my set with that of Mr WEDGWOOD, at various temperatures, in furnaces of great size and steadiness. The result has proved, that my pieces agree as well with each other as his, though with my set each temperature is indicated by a different degree of the scale. I have thus been enabled to construct a table, by which my observations have been corrected, so that the temperatures mentioned in this paper are such as would have been indicated by Mr WEDGWOOD's pieces. By Mr WEDGWOOD's pieces, I mean those of the only set which has been sold to the public, and by which the melting heat of pure silver is indicated at the 22d degree. I am well aware, that the late Mr WEDGWOOD, in his Table of Fusibilities, has stated that fusion was taking place at the 28th degree; but I am convinced that his observations must have been made with some set different from that which was afterwards sold.

the whole cradle ; when any space remained, it was filled up by a piece of chalk dressed for the purpose. (Fig. 4. represents the cradle filled, as just described).

THINGS being thus prepared, the gun-barrel, placed erect with its muzzle upwards, was half filled with the liquid fusible metal. The cradle was then introduced into the barrel, and plunged to the bottom of the liquid, so that the carbonate was placed very near the breech, (as represented in fig. 5, the fusible metal standing at *o*). The air-tube (B) being placed so as to enter the liquid with its muzzle downwards, retained great part of the air it originally contained, though some of it might be driven off by the heat, so as to escape through the liquid. The metal being now allowed to cool, and to fix round the cradle and ramrod, the air remaining in the air-tube was effectually confined, and all was held fast. The barrel being then filled to the brim with fusible metal, the apparatus was ready for the application of heat to the breech, (as shewn in fig. 6.)

IN the experiments made at this time, I used a square brick furnace (figs. 7 and 8), having a muffle (*r s*) traversing it horizontally and open at both ends. This muffle being supported in the middle by a very slender prop, was exposed to fire from below, as well as all round. The barrel was placed in the muffle, with its breech in the hottest part, and the end next the muzzle projecting beyond the furnace, and surrounded with cloths which were drenched with water from time to time. (This arrangement is shewn in fig. 7). In this situation, the fusible metal surrounding the cradle being melted, the air contained in the air-tube would of course seek the highest position, and its first place in the air-tube would be occupied by fusible metal. (In fig. 6., the new position of the air is shewn at *p q*).

AT the conclusion of the experiment, the metal was generally removed by placing the barrel in the transverse muffle, with its muzzle pointing a little downwards, and so that the heat was applied first to the muzzle, and then to the rest of the barrel in succession. (This operation is shewn in fig. 8). In some of the first of these experiments, I loosened the cradle, by plunging the barrel into heated brine, or a strong solution of muriate of lime; which last bears a temperature of 250° of FAHRENHEIT before it boils. For this purpose, I used a pan three inches in diameter, and three feet deep, having a flat basin at top to receive the liquid when it boiled over. The method answered, but was troublesome, and I laid it aside. I have had occasion, lately, however, to resume it in some experiments in which it was of consequence to open the barrel with the least possible heat*.

By these methods I made a great number of experiments, with results that were highly interesting in that stage of the business, though their importance is so much diminished by the subsequent progress of the investigation, that I think it proper to mention but very few of them.

ON the 31st of March 1801, I rammed forty grains of pounded chalk into a tube of green bottle-glass, and placed it in the cradle as above described. A pyrometer in the muffle along with the barrel indicated 33° . The barrel was exposed to heat during seventeen, or eighteen minutes. On withdrawing the cradle, the carbonate was found in one solid mass, which had visibly shrunk in bulk, the space thus left within the tube being accurately

* In many of the following experiments, lead was used in place of the fusible metal, and often with success; but I lost many good results in this way: for the heat required to liquefy the lead, approaches so near to redness, that it is difficult to disengage the cradle without applying a temperature by which the carbonate is injured. I have found it answer well, to surround the cradle and a few inches of the rod, with fusible metal, and to fill the rest of the barrel with lead.

accurately filled with metal, which plated the carbonate all over without penetrating it in the least, so that the metal was easily removed. The weight was reduced from forty to thirty-six grains. The substance was very hard, and resisted the knife better than any result of the kind previously obtained; its fracture was crystalline, bearing a resemblance to white saline marble; and its thin edges had a decided semitransparency, a circumstance first observed in this result.

ON the 3d of March of the same year, I made a similar experiment, in which a pyrometer-piece was placed within the barrel, and another in the muffle; they agreed in indicating 23° . The inner tube, which was of Reaumur's porcelain, contained eighty grains of pounded chalk. The carbonate was found, after the experiment, to have lost $3\frac{1}{2}$ grains. A thin rim, less than the 20th of an inch in thickness, of whitish matter, appeared on the outside of the mass. In other respects, the carbonate was in a very perfect state; it was of a yellowish colour, and had a decided semitransparency and saline fracture. But what renders this result of the greatest value, is, that on breaking the mass, a space of more than the tenth of an inch square, was found to be completely crystallized, having acquired the rhomboidal fracture of calcareous spar. It was white and opaque, and presented to the view three sets of parallel plates which are seen under three different angles. This substance, owing to partial calcination and subsequent absorption of moisture, had lost all appearance of its remarkable properties in some weeks after its production; but this appearance has since been restored, by a fresh fracture, and the specimen is now well preserved by being hermetically inclosed.

III.

Experiments made in Tubes of Porcelain.—Tubes of Wedgwood's Ware.—Methods used to confine the Carbonic Acid, and to close the Pores of the Porcelain in a Horizontal Apparatus.—Tubes made with a view to these Experiments.—The Vertical Apparatus adopted.—View of Results obtained, both in Iron and Porcelain.—The Formation of Limestone and Marble.—Inquiry into the Cause of the partial Calcinations.—Tubes of Porcelain weighed previous to breaking.—Experiments with Porcelain Tubes proved to be limited.

WHILE I was carrying on the above-mentioned experiments, I was occasionally occupied with another set, in tubes of porcelain. So much, indeed, was I prepossessed in favour of this last mode, that I laid gun-barrels aside, and adhered to it during more than a year. The methods followed with this substance, differ widely from those already described, though founded on the same general principles.

I PROCURED from Mr WEDGWOOD's manufactory at Etruria, in Staffordshire, a set of tubes for this purpose, formed of the same substance with the white mortars, in common use, made there. These tubes were fourteen inches long, with a bore of half an inch diameter, and thickness of 0.2; being closed at one end (figs. 9, 10, 11, 12, 13.)

I PROPOSED to ram the carbonate of lime into the breech (Fig. 9. A); then filling the tube to within a small distance of its muzzle with pounded flint (B), to fill that remainder (C) with common borax of the shops (borat of soda) previously reduced to glass, and then pounded; to apply heat to the muzzle alone, so as to convert that borax into solid glass; then, reversing the operation, to keep the muzzle cold, and apply the requisite heat to the carbonate lodged in the breech.

I THUS expected to confine the carbonic acid; but the attempt was attended with considerable difficulty, and has led to the employment of various devices, which I shall now shortly enumerate, as they occurred in the course of practice. The simple application of the principle was found insufficient, from two causes: First, The carbonic acid being driven from the breach of the tube, towards the muzzle, among the pores of the pounded filex, escaped from the compressing force, by lodging itself in cavities which were comparatively cold: Secondly, The glass of borax, on cooling, was always found to crack very much, so that its tightness could not be depended on.

To obviate both these inconveniences at once, it occurred to me, in addition to the first arrangement, to place some borax (fig. 10. C) so near the breach of the tube, as to undergo heat along with the carbonate (A); but interposing between this borax and the carbonate, a stratum of filex (B), in order to prevent contamination. I trusted that the borax in a liquid or viscid state, being thrust outwards by the expansion of the carbonic acid, would press against the filex beyond it (D), and totally prevent the elastic substances from escaping out of the tube, or even from wandering into its cold parts.

In some respects, this plan answered to expectation. The glass of borax, which can never be obtained when cold, without innumerable cracks, unites into one continued viscid mass in the lowest red-heat; and as the stress in these experiments, begins only with redness, the borax being heated at the same time with the carbonate, becomes united and impervious, as soon as its action is necessary. Many good results were accordingly obtained in this way. But I found, in practice, that as the heat rose, the borax began to enter into too thin fusion, and was often lost among the pores of the filex, the space in which it had lain being found empty on breaking the tube. It was therefore

therefore found necessary to oppose something more substantial and compact, to the thin and penetrating quality of pure borax.

IN searching for some such substance, a curious property of bottle-glass occurred accidentally. Some of this glass, in powder, having been introduced into a muffle at the temperature of about 20° of WEDGWOOD; the powder, in the space of about a minute, entered into a state of viscid agglutination, like that of honey, and in about a minute more, (the heat always continuing unchanged,) consolidated into a firm and compact mass of *Reaumur's porcelain* *. It now appeared, that by placing this substance immediately behind the borax, the penetrating quality of this last might be effectually restrained; for, *Reaumur's porcelain* has the double advantage of being refractory, and of not cracking by change of temperature. I found, however, that in the act of consolidation, the pounded bottle-glass shrunk, so as to leave an opening between its mass and the tube, through which the borax, and, along with it, the carbonic acid, was found to escape. But the object in view was obtained by means of a mixture of pounded bottle-glass, and pounded flint, in equal parts. This compound still agglutinates, not indeed into a mass so hard as *Reaumur's porcelain*, but sufficiently so for the purpose; and this being done without any sensible contraction, an effectual barrier was opposed to the borax; (this arrangement is shewn in fig. 11.); and thus the method of closing the tubes was rendered so complete, as seldom to fail in practice †. A still further refinement upon this me-

M 2

thod

* IN the same temperature, a mass of the glass of equal bulk would undergo the same change; but it would occupy an hour.

† A substance equally efficacious in restraining the penetrating quality of borax, was discovered by another accident. It consists of a mixture of borax and common sand, by which a substance is formed, which, in heat, assumes the state of a very tough paste, and becomes hard and compact on cooling.

thod was found to be of advantage. A second series of powders, like that already described, was introduced towards the muzzle, (as shewn in fig. 12.). During the first period of the experiment, this last-mentioned series was exposed to heat, with all the outward half of the tube (*ab*); by this means, a solid mass was produced, which remained cold and firm during the subsequent action of heat upon the carbonate.

I soon found, that notwithstanding all the above-mentioned precautions, the carbonic acid made its escape, and that it pervaded the substance of the Wedgwood tubes, where no flaw could be traced. It occurred to me, that this defect might be remedied, were borax, in its thin and penetrating state of fusion, applied to the inside of the tube; and that the pores of the porcelain might thus be closed, as those of leather are closed by oil, in an air-pump. In this view, I rammed the carbonate into a small tube, and surrounded it with pounded glass of borax, which, as soon as the heat was applied, spread on the inside of the large tube, and effectually closed its pores. In this manner, many good experiments were made with barrels lying horizontally in common muffles, (the arrangement just described being represented in fig. 13.)

I WAS thus enabled to carry on experiments with this porcelain, to the utmost that its strength would bear. But I was not satisfied with the force so exerted; and, hoping to obtain tubes of a superior quality, I spent much time in experiments with various porcelain compositions. In this, I so far succeeded, as to produce tubes by which the carbonic acid was in a great measure retained without any internal glaze. The best material I found for this purpose, was the pure porcelain-clay of Cornwall, or a composition in the proportion of two of this clay to one of what the potters call *Cornish-stone*, which I believe to be a granite in a state of decomposition. These tubes were seven or eight inches long, with a bore tapering

tapering from 1 inch to 0.6. Their thickness was about 0.3 at the breech, and tapered towards the muzzle to the thinness of a wafer.

I NOW adopted a new mode of operation, placing the tube vertically, and not horizontally, as before. By observing the thin state of borax whilst in fusion, I was convinced, that it ought to be treated as a complete liquid, which being supported in the course of the experiment from below, would secure perfect tightness, and obviate the failure which often happened in the horizontal position, from the falling of the borax to the lower side.

IN this view, (fig. 16.); I filled the breech in the manner described above, and introduced into the muzzle some borax (C) supported at the middle of the tube by a quantity of filix mixed with bottle-glass (B). I placed the tube, so prepared, with its breech plunged into a crucible filled with sand (E), and its muzzle pointing upwards. It was now my object to apply heat to the muzzle-half, whilst the other remained cold. In that view, I constructed a furnace (fig. 14. and 15.); having a muffle placed vertically (*cd*), surrounded on all sides with fire (*ce*), and open both above (at *c*), and below (at *d*). The crucible just mentioned, with its tube, being then placed on a support directly below the vertical muffle, (as represented in fig. 14. at F), it was raised, so that the half of the tube next the muzzle was introduced into the fire. In consequence of this, the borax was seen from above to melt, and run down in the tube, the air contained in the powder escaping in the form of bubbles, till at last the borax stood with a clear and steady surface like that of water. Some of this salt being thrown in from above, by means of a tube of glass, the liquid surface was raised nearly to the muzzle, and, after all had been allowed to become cold, the position of the tube was reversed; the muzzle being now plunged

ged into the sand, (as in fig. 17.), and the breech introduced into the muffle. In several experiments, I found it answer well, to occupy great part of the space next the muzzle, with a rod of sand and clay previously baked, (fig. 19. K K), which was either introduced at first, along with the pounded borax, or, being made red hot, was plunged into it when in a liquid state. In many cases I assisted the compactness of the tube by means of an internal glaze of borax; the carbonate being placed in a small tube, (as shewn in fig. 18.)

THESE devices answered the end proposed: Three-fourths of the tube next the muzzle was found completely filled with a mass, having a concave termination at both ends, (*f* and *g* figs. 17. 18. 19.), shewing that it had stood as a liquid in the two opposite positions in which heat had been applied to it. So great a degree of tightness indeed was obtained in this way, that I found myself subjected to an unforeseen source of failure. A number of the tubes failed, not by explosion, but by the formation of a minute longitudinal fissure at the breech, through which the borax and carbonic acid escaped. I saw that this arose from the expansion of the borax when in a liquid state, as happened with the fusible metal in the experiments with iron-barrels; for, the crevice here formed, indicated the exertion of some force acting very powerfully, and to a very small distance. Accordingly, this source of failure was remedied by the introduction of a very small air-tube. This, however, was used only in a few experiments.

IN the course of the years 1801, 1802, and 1803, I made a number of experiments, by the various methods above described, amounting, together with those made in gun-barrels, to one hundred and fifty-six. In an operation so new, and in which the apparatus was strained to the utmost of its power, constant success could not be expected, and in fact many experiments failed, wholly or partially. The results, however, upon the

the whole, were satisfactory, since they seemed to establish some of the essential points of this inquiry.

THESE experiments prove, that, by mechanical constraint, the carbonate of lime can be made to undergo strong heat, without calcination, and to retain almost the whole of its carbonic acid, which, in an open fire, at the same temperature, would have been entirely driven off: and that, in these circumstances, heat produces some of the identical effects ascribed to it in the Huttonian Theory.

By this joint action of heat and pressure, the carbonate of lime which had been introduced in the state of the finest powder, is agglutinated into a firm mass, possessing a degree of hardness, compactness, and specific gravity *, nearly approaching to these qualities in a sound limestone; and some of the results, by their saline fracture, by their semitransparency, and their susceptibility of polish, deserve the name of marble.

THE same trials have been made with all calcareous substances; with chalk, common limestone, marble, spar, and the shells of fish. All have shewn the same general property, with some varieties as to temperature. Thus, I found, that, in the same circumstances, chalk was more susceptible of agglutination than spar; the latter requiring a heat two degrees higher than the former, to bring it to the same pitch of agglutination.

THE chalk used in my first experiments, always assumed the character of a yellow marble, owing probably to some slight contamination of iron. When a solid piece of chalk, whose bulk had been previously measured in the gage of Wedgwood's pyrometer was submitted to heat under compression, its contraction was remarkable, proving the approach of the particles during their consolidation; on these occasions, it was found

to

* See Appendix.

to shrink three times more than the pyrometer-pieces in the same temperature. It lost, too, almost entirely, its power of imbibing water, and acquired a great additional specific gravity. On several occasions, I observed, that masses of chalk, which, before the experiment, had shewn one uniform character of whiteness, assumed a stratified appearance, indicated by a series of parallel layers of a brown colour. This circumstance may hereafter throw light on the geological history of this extraordinary substance.

I HAVE said, that, by mechanical constraint, almost the whole of the carbonic acid was retained. And, in truth, at this period, some loss of weight had been experienced in all the experiments, both with iron and porcelain. But even this circumstance is valuable, by exhibiting the influence of the carbonic acid, as varied by its quantity.

WHEN the loss exceeded 10 or 15 *per cent* *. of the weight of the carbonate, the result was always of a friable texture, and without any stony character; when less than 2 or 3 *per cent*. it was considered as good, and possessed the properties of a natural carbonate. In the intermediate cases, when the loss amounted, for instance, to 6 or 8 *per cent.*, the result was sometimes excellent at first, the substance bearing every appearance of soundness, and often possessing a high character of crystallization; but it was unable to resist the action of the air; and, by attracting carbonic acid or moisture, or both, crumbled to dust more or less rapidly, according to circumstances. This seems to prove, that the carbonate of lime, though not fully saturated with carbonic acid, may possess the properties of limestone; and perhaps a difference of
this

* I have found, that, in open fire, the entire loss sustained by the carbonate varies in different kinds from 42 to 45.5 *per cent*.

this kind may exist among natural carbonates, give rise to their different degrees of durability.

I HAVE observed, in many cases, that the calcination has reached only to a certain depth into the mass; the internal part remaining in a state of complete carbonate, and, in general, of a very fine quality. The partial calcination seems thus to take place in two different modes. By one, a small proportion of carbonic acid is taken from each particle of carbonate; by the other, a portion of the carbonate is quite calcined, while the rest is left entire. Perhaps one result is the effect of a feeble calcining cause, acting during a long time, and the other of a strong cause, acting for a short time.

SOME of the results which seemed the most perfect when first produced, have been subject to decay, owing to partial calcination. It happened, in some degree, to the beautiful specimen produced on the 3d of March 1801, though a fresh fracture has restored it.

A SPECIMEN, too, of marble, formed from pounded spar, on 15th May 1801, was so complete as to deceive the workman employed to polish it, who declared, that, were the substance a little whiter, the quarry from which it was taken would be of great value, if it lay within reach of a market. Yet, in a few weeks after its formation, it fell to dust.

NUMBERLESS specimens, however, have been obtained, which resist the air, and retain their polish as well as any marble. Some of them continue in a perfect state, though they have been kept without any precaution during four or five years. That set, in particular, remain perfectly entire, which were shewn last year in this Society, though some of them were made in 1799, some in 1801 and 1802, and though the first eleven were long soaked in water, in the trials made of their specific gravity.

A CURIOUS circumstance occurred in one of these experiments, which may hereafter lead to important consequences. Some rust of iron had accidentally found its way into the tube: 10 grains of carbonate were used, and a heat of 28° was applied. The tube had no flaw; but there was a certainty that the carbonic acid had escaped through its pores. When broken, the place of the carbonate was found occupied, partly by a black slaggy matter, and partly by sphericles of various sizes, from that of a small pea downwards, of a white substance, which proved to be quicklime; the sphericles being interspersed through the slag, as spar and agates appear in whinstone. The slag had certainly been produced by a mixture of the iron with the substance of the tube; and the spherical form of the quicklime seems to shew, that the carbonate had been in fusion along with the slag, and that they had separated on the escape of the carbonic acid.

THE subject was carried thus far in 1803, when I should probably have published my experiments, had I not been induced to prosecute the inquiry by certain indications, and accidental results, of a nature too irregular and uncertain to meet the public eye, but which convinced me, that it was possible to establish, by experiment, the truth of all that was hypothetically assumed in the Huttonian Theory.

THE principal object was now to accomplish the entire fusion of the carbonate, and to obtain spar as the result of that fusion, in imitation of what we conceive to have taken place in nature.

It was likewise important to acquire the power of retaining all the carbonic acid of the carbonate, both on account of the fact itself, and on account of its consequences; the result being visibly improved by every approach towards complete saturation. I therefore became anxious to investigate the cause of the partial calcinations which had always taken place, to

a greater or a less degree, in all these experiments. The question naturally suggests itself, What has become of the carbonic acid, separated in these partial calcinations from the earthy basis? Has it penetrated the vessel, and escaped entirely, or has it been retained within it in a gaseous, but highly compressed state? It occurred to me, that this question might be easily resolved, by weighing the vessel before and after the action of heat upon the carbonate.

WITH iron, a constant and inappreciable source of irregularity existed in the oxidation of the barrel. But with porcelain the thing was easy; and I put it in practice in all my experiments with this material, which were made after the question had occurred to me. The tube was weighed as soon as its muzzle was closed, and again, after the breech had been exposed to the fire; taking care, in both cases, to allow all to cool. In every case, I found some loss of weight, proving, that even in the best experiments, the tubes were penetrated to a certain degree. I next wished to try if any of the carbonic acid separated, remained within the tube in a gaseous form; and in that view, I wrapt the tube, which had just been weighed, in a sheet of paper, and placed it, so surrounded, on the scale of the balance. As soon as its weight was ascertained, I broke the tube by a smart blow, and then replaced upon the scale the paper containing all the fragments. In those experiments, in which entire calcination had taken place, the weight was found not to be changed, for all the carbonic acid had already escaped during the action of heat. But in the good results, I always found that a loss of weight was the consequence of breaking the tube.

THESE facts prove, that both causes of calcination had operated in the porcelain tubes; that, in the cases of small loss, part of the carbonic acid had escaped through the vessel, and that part had been retained within it. I had in view methods

by which the last could be counteracted ; but I saw no remedy for the first. I began, therefore, to despair of ultimate success with tubes of porcelain *.

ANOTHER circumstance confirmed me in this opinion. I found it impracticable to apply a heat above 27° to these tubes, when charged as above with carbonate, without destroying them, either by explosion, by the formation of a minute rent, or by the actual swelling of the tube. Sometimes this swelling took place to the amount of doubling the internal diameter, and yet the porcelain held tight, the carbonate sustaining but a very small loss. This ductility of the porcelain in a low heat is a curious fact, and shews what a range of temperature is embraced by the gradual transition of some substances from a solid to a liquid state : For the same porcelain, which is thus susceptible of being stretched out without breaking in a heat of 27° , stands the heat of 152° , without injury, when exposed to no violence, the angles of its fracture remaining sharp and entire.

IV.

* I am nevertheless of opinion, that, in some situations, experiments with compression may be carried on with great ease and advantage in such tubes. I allude to the situation of the geologists of France and Germany, who may easily procure, from their own manufactories, tubes of a quality far superior to any thing made for sale in this country.

IV.

Experiments in Gun-Barrels resumed.—The Vertical Apparatus applied to them.—Barrels bored in solid Bars.—Old Sable Iron.—Fusion of the Carbonate of Lime.—Its action on Porcelain.—Additional apparatus required in consequence of that action.—Good results; in particular, four experiments, illustrating the theory of Internal Calcination, and shewing the efficacy of the Carbonic Acid as a Flux.

SINCE I found that, with porcelain tubes, I could neither confine the carbonic acid entirely, nor expose the carbonate in them to strong heats; I at last determined to lay them aside, and return to barrels of iron, with which I had formerly obtained some good results, favoured, perhaps, by some accidental circumstances.

ON the 12th of February 1803, I began a series of experiments with gun-barrels, resuming my former method of working with the fusible metal, and with lead; but altering the position of the barrel from horizontal to vertical; the breech being placed upwards during the action of heat on the carbonate. This very simple improvement has been productive of advantages no less remarkable, than in the case of the tubes of porcelain. In this new position, the included air, quitting the air-tube on the fusion of the metal, and rising to the breech, is exposed to the greatest heat of the furnace, and must therefore react with its greatest force; whereas, in the horizontal position, that air might go as far back as the fusion of the metal reached, where its elasticity would be much feebler. The same disposition enabled me to keep the muzzle of the barrel plunged, during the action of heat, in a vessel filled with water; which contributed

contributed very much both to the convenience and safety of these experiments.

IN this view, making use of the brick-furnace with the vertical muffle, already described in page 93. I ordered a pit (*aaa*, fig. 20.) to be excavated under it, for the purpose of receiving a water-vessel. This vessel (represented separately, fig. 21.) was made of cast iron; it was three inches in diameter, and three feet deep; and had a pipe (*de*) striking off from it at right angles, four or five inches below its rim, communicating with a cup (*ef*) at the distance of about two feet. The main vessel being placed in the pit (*aa*) directly below the vertical muffle, and the cup standing clear of the furnace, water poured into the cup flowed into the vessel, and could thus conveniently be made to stand at any level. (The whole arrangement is represented in fig. 20.) The muzzle of the barrel (*g*) being plunged into the water, and its breech (*b*) reaching up into the muffle, as far as was found convenient, its position was secured by an iron chain (*gf*). The heat communicated downwards generally kept the surface of the water (at *c*) in a state of ebullition; the waste thus occasioned being supplied by means of the cup, into which, if necessary, a constant stream could be made to flow.

As formerly, I rammed the carbonate into a tube of porcelain, and placed it in a cradle of iron, along with an air-tube and a pyrometer; the cradle being fixed to a rod of iron, which rod I now judged proper to make as large as the barrel would admit, in order to exclude as much of the fusible metal as possible; for the expansion of the liquid metal being in proportion to the quantity heated, the more that quantity could be reduced, the less risk there was of destroying the barrels.

IN the course of practice, a simple mode occurred of removing the metal and withdrawing the cradle: it consisted in placing
cing

cing the barrel with its muzzle downwards, so as to keep the breech above the furnace and cold, while its muzzle was exposed to strong heat in the muffle. In this manner, the metal was discharged from the muzzle, and the position of the barrel being lowered by degrees, the whole metal was removed in succession, till at last the cradle and its contents became entirely loose. As the metal was delivered, it was received in a crucible, filled with water, standing on a plate of iron placed over the pit, which had been used, during the first stage of the experiment, to contain the water-veffel. It was found to be of service, especially where lead was used, to give much more heat to the muzzle than simply what was required to liquefy the metal it contained; for when this was not done, the muzzle growing cold as the breech was heating, some of the metal delivered from the breech was congealed at the muzzle, so as to stop the passage.

ACCORDING to this method, many experiments were made in gun-barrels, by which some very material steps were gained in the investigation.

ON the 24th February, I made an experiment with spar and chalk; the spar being placed nearest to the breech of the barrel, and exposed to the greatest heat, some baked clay intervening between the carbonates. On opening the barrel, a long-continued hissing noise was heard. The spar was in a state of entire calcination; the chalk, though crumbling at the outside, was uncommonly hard and firm in the heart. The temperature had risen to 32° .

IN this experiment, we have the first clear example, in iron barrels, of what I call *Internal Calcination*; that is to say, where the carbonic acid separated from the earthy basis, has been accumulated in cavities within the barrel. For, subsequently to the action of strong heat, the barrel had been completely cooled; the air therefore introduced by means of the air-tube, must have

have resumed its original bulk, and by itself could have no tendency to rush out; the heat employed to open the barrel being barely sufficient to soften the metal. Since, then, the opening of the barrel was accompanied by the discharge of elastic matter in great abundance, it is evident, that this must have proceeded from something superadded to the air originally included, which could be nothing but the carbonic acid of the carbonate. It follows, that the calcination had been, in part at least, internal; the separation of the acid from the earthy matter being complete where the heat was strongest, and only partial where the intensity was less.

THE chemical principles stated in a former part of this paper, authorized us to expect a result of this kind. As heat, by increasing the volatility of the acid, tended to separate it from the earth, we had reason to expect, that, under the same compression, but in different temperatures, one portion of the carbonate might be calcined, and another not: And that the least heated of the two, would be least exposed to a change not only from want of heat, but likewise in consequence of the calcination of the other mass; for the carbonic acid disengaged by the calcination of the hottest of the two, must have added to the elasticity of the confined elastic fluid, so as to produce an increase of compression. By this means, the calcination of the coldest of the two might be altogether prevented, and that of the hottest might be hindered from making any further advancement. This reasoning seemed to explain the partial calcinations which had frequently occurred where there was no proof of leakage; and it opened some new practical views in these experiments, of which I availed myself without loss of time. If the internal calcination of one part of an inclosed mass, promotes the compression of other masses included along with it, I conceived that we might forward our views very much by placing a small quantity of carbonate,

nate, carefully weighed, in the same barrel with a large quantity of that substance; and by arranging matters so that the small fiducial part should undergo a moderate heat, while a stronger heat, capable of producing internal calcination, should be applied to the rest of the carbonate. In this manner, I made many experiments, and obtained results which seemed to confirm this reasoning, and which were often very satisfactory, though the heat did not always exert its greatest force where I intended it to do so.

ON the 28th of February, I introduced some carbonate, accurately weighed, into a small porcelain tube, placed within a larger one, the rest of the large tube being filled with pounded chalk; these carbonates, together with some pieces of chalk, placed along with the large tube in the cradle, weighing in all 195.7 grains. On opening the barrel, air rushed out with a long-continued hissing noise. The contents of the little tube were lost by the intrusion of some borax which had been introduced over the filex, in order to exclude the fusible metal. But the rest of the carbonate, contained in the large tube, came out in a fine state, being porous and frothy throughout; sparkling every where with facettes, the angular form of which was distinguishable in some of the cavities by help of a lens: in some parts the substance exhibited the rounding of fusion; in many it was in a high degree transparent. It was yellow towards the lower end, and at the other almost colourless. At the upper end, the carbonate seemed to have united with the tube, and at the places of contact to have spread upon it; the union having the appearance of a mutual action. The general mass of carbonate effervesced in acid violently, but the thin stratum immediately contiguous to the tube, feebly, if at all.

ON the 3d of March, I introduced into a very clean tube of porcelain 36.8 of chalk. The tube was placed in the upper

part of the cradle, the remaining space being filled with two pieces of chalk, cut for the purpose; the uppermost of these being excavated, so as to answer the purpose of an air-tube. The pieces thus added, were computed to weigh about 300 grains. There was no pyrometer used; but the heat was guessed to be about 30° . After the barrel had stood during a few minutes in its delivering position, the whole lead, with the rod and cradle, were thrown out with a smart report, and with considerable force. The lowermost piece of chalk had scarcely been acted upon by heat. The upper part of the other piece was in a state of marble, with some remarkable facettes. The carbonate, in the little tube, had shrunk very much during the first action of heat, and had begun to sink upon itself, by a further advancement towards liquefaction. The mass was divided into several cylinders, lying confusedly upon each other; this division arising from the manner in which the pounded chalk was rammed into the tube in successive portions. In several places, particularly at the top, the carbonate was very porous, and full of decided air-holes, which could not have been formed but in a soft substance; the globular form and shining surface of all these cavities, clearly indicating fusion. The substance was semitransparent; in some places yellow, and in some colourless. When broken, the solid parts shewed a saline fracture, composed of innumerable facettes. The carbonate adhered, from end to end, to the tube, and incorporated with it, so as to render it impossible to ascertain what loss had been sustained. In general, the line of contact was of a brown colour; yet there was no room for suspecting the presence of any foreign matter, except, perhaps, from the iron-rod which was used in ramming down the chalk. But, in subsequent experiments, I have observed the same brown or black colour at the union of the carbonate with the porcelain tubes, where the powder had been purposely rammed with a piece of wood;

wood ; so that this colour, which has occurred in almost every similar case, remains to be accounted for. The carbonate effervesced violently with acid ; the substance in contact with the tube, doing so, however, more feebly than in the heart, leaving a copious deposit of white sandy matter, which is doubtless a part of the tube, taken up by the carbonate in fusion.

ON the 24th of March, I made a similar experiment, in a stout gun-barrel, and took some care, after the application of heat, to cool the barrel slowly, with a view to crystallization. The whole mass was found in a fine state, and untouched by the lead ; having a semitransparent and saline structure, with various facettes. In one part, I found the most decided crystallization I had obtained, though of a small size : owing to its transparency it was not easily visible, till the light was made to reflect from the crystalline surface, which then produced a dazzle, very observable by the naked eye : when examined by means of a lens, it was seen to be composed of several plates, broken irregularly in the fracture of the specimen, all of which are parallel to each other, and reflect under the same angle, so as to unite in producing the dazzle. This structure was observable equally well in both parts of the broken specimen. In a former experiment, as large a facette was obtained in a piece of solid chalk ; but this result was of more consequence, as having been produced from chalk previously pounded.

THE foregoing experiments proved the superior efficacy of iron vessels over those of porcelain, even where the thickness was not great ; and I persevered in making a great many experiments with gun-barrels, by which I occasionally obtained very fine results : but I was at last convinced, that their thickness was not sufficient to ensure regular and steady success : For this purpose, it appeared proper to employ vessels of such strength, as to bear a greater expansive force than was just necessary ; since, occasionally, (owing to our ignorance of the relation

lation between the various forces of expansion, affinity, tenacity, &c.), much more strain has been given to the vessels than was requisite. In such cases, barrels have been destroyed, which, as the results have proved, had acted with sufficient strength during the first stages of the experiments, though they had been unable to resist the subsequent overstrain. Thus, my success with gun-barrels, depended on the good fortune of having used a force no more than sufficient, to constrain the carbonic acid, and enable it to act as a flux on the lime. I therefore determined to have recourse to iron barrels of much greater strength, and tried various modes of construction.

I HAD some barrels executed by wrapping a thick plate of iron round a mandrel, as is practised in the formation of gun-barrels; and likewise by bringing the two flat sides together, so as to unite them by welding. These attempts, however, failed. I next thought of procuring bars of iron, and of having a cavity bored out of the solid, so as to form a barrel. In this manner I succeeded well. The first barrel I tried in this way was of small bore, only half an inch: Its performance was highly satisfactory, and such as to convince me, that the mode now adopted was the best of any that I had tried. Owing to the smallness of the bore, a pyrometer could not be used internally, but was placed upon the breech of the barrel, as it stood in the vertical muffle. In this position, it was evidently exposed to a much less heat than the fiducial part of the apparatus, which was always placed, as nearly as could be guessed, at the point of greatest heat.

ON the 4th of April, an experiment was made in this way with some spar; the pyrometer on the breech giving 33° . The spar came out clean, and free from any contamination, adhering to the inside of the porcelain tube: it was very much shrunk, still retaining a cylindrical form, though bent by partial adhesions. Its surface bore scarcely any remains of the impression taken by
the

the powder, on ramming it into the tube: it had, to the naked eye, the roughness and semitransparency of the pith of a rush stripped of its outer skin. By the lens, this same surface was seen to be glazed all over, though irregularly, shewing here and there some air-holes. In fracture, it was semitransparent, more vitreous than crystalline, though having a few facettes: the mass, was seemingly formed of a congeries of parts, in themselves quite transparent: and, at the thin edges, small pieces were visible of perfect transparency. These must have been produced in the fire; for the spar had been ground with water, and passed through sieves, the same with the finest of those used at Etruria, as described by Mr WEDGWOOD, in his paper on the construction of his Pyrometer.

WITH the same barrel I obtained many interesting results, giving as strong proofs of fusion as in any former experiments; with this remarkable difference, that, in these last, the substance was compact, with little or no trace of frothing. In the gun-barrels where fusion had taken place, there had always been a loss of 4 or 5 *per cent.*, connected, probably, with the frothing. In these experiments, for a reason soon to be stated, the circumstance of weight could not be observed; but appearances led me to suppose, that here the loss had been small, if any.

ON the 6th of April, I made another experiment with the square barrel, whose thickness was now much reduced by successive scales, produced by oxidation, and in which a small rent began to appear externally, which did not, however, penetrate to the bore. The heat rose high, a pyrometer on the breech of the barrel giving 37° . On removing the metals, the cradle was found to be fixed, and was broken in the attempts made to withdraw it. The rent was much widened externally: but it was evident, that the barrel had not been laid open, for part of the carbonate was in a state of saline marble;

marble ; another was hard and white, without any saline grains, and scarcely effervesced in acid. It was probably quicklime, formed by internal calcination, but in a state that has not occurred in any other experiment.

THE workman whom I employed to take out the remains of the cradle, had cut off a piece from the breech of the barrel, three or four inches in length. As I was examining the crack which was seen in this piece, I was surprised to see the inside of the barrel lined with a set of transparent and well-defined crystals, of small size, yet visible by the naked eye. They lay together in some places, so as to cover the surface of the iron with a transparent coat ; in others they were detached, and scattered over the surface. Unfortunately, the quantity of this substance was too small to admit of much chemical examination ; but I immediately ascertained, that it did not in the least effervesce in acid, nor did it seem to dissolve in it. The crystals were in general transparent and colourless, though a few of them were tinged seemingly with iron. Their form was very well defined, being flat, with oblique angles, and bearing a strong resemblance to the crystals of the Lamellated Stylbite of HAÜY. Though made above two years ago, they still retain their form and transparency unchanged. Whatever this substance may be, its appearance, in this experiment, is in the highest degree interesting, as it seems to afford an example of the mode in which Dr HUTTON supposes many internal cavities to have been lined, by the sublimation of substances in a state of vapour ; or, held in solution, by matters in a gaseous form. For, as the crystals adhered to a part of the barrel, which must have been occupied by air during the action of heat, it seems next to certain that they were produced by sublimation.

THE very powerful effects produced by this last barrel, the size of which (reduced, indeed, by repeated oxidation) was not
above

above an inch square, made me very anxious to obtain barrels of the same substance, which being made of greater size, ought to afford results of extreme interest. I found upon inquiry, that this barrel was not made of Swedish iron, as I at first supposed, but of what is known by the name of *Old Sable*, from the figure of a Sable stamped upon the bars; that being the armorial badge of the place in Siberia where this iron is made*.

A WORKMAN explained to me some of the properties of different kinds of irons, most interesting in my present pursuit; and he illustrated what he said by actual trial. All iron, when exposed to a certain heat, crushes and crumbles under the hammer; but the temperature in which this happens, varies with every different species. Thus, as he shewed me, cast iron crushes in a dull-red heat, or perhaps about 15° of WEDGWOOD; steel, in a heat perhaps of 30° ; Swedish iron, in a bright white heat, perhaps of 50° or 60° ; old sable, itself, likewise yields, but in a much higher heat, perhaps of 100° . I merely guessed at these temperatures; but I am certain of this, that in a heat similar to that in which Swedish iron crumbled under the hammer, the old sable withstood a strong blow, and seemed to possess considerable firmness. It is from a knowledge of this quality, that the blacksmith, when he first takes his iron from the forge, and lays it on the anvil, begins by very gentle blows, till the temperature has sunk to the degree in which the iron can bear the hammer. I observed, as the strong heat of the forge acted on the Swedish iron, that it began to boil at the surface, clearly indicating the discharge of some gaseous matter; whereas, the old sable, in the same circumstances, acquired the shining surface of a liquid, and melted away without any effervescence. I procured, at this time, a considerable number

* I WAS favoured with this account of it by the late Professor ROBISON.

number of bars of that iron, which fully answered my expectations.

By the experiments last mentioned, a very important point was gained in this investigation; the complete fusibility of the carbonate under pressure being thereby established. But from this very circumstance, a necessity arose of adding some new devices to those already described: for the carbonate, in fusion, spreading itself on the inside of the tube containing it, and the two uniting firmly together, so as to be quite inseparable, it was impossible, after the experiment, to ascertain the weight of the carbonate by any method previously used. I therefore determined in future to adopt the following arrangement.

A SMALL tube of porcelain (*ik*, fig. 23.) was weighed by means of a counterpoise of sand, or granulated tin; then the carbonate was firmly rammed into the tube, and the whole weighed again: thus the weight of the carbonate, previous to the experiment, was ascertained. After the experiment, the tube, with its contents, was again weighed; and the variation of weight obtained, independently of any mutual action that had taken place between the tube and the carbonate. The balance which I used, turned, in a constant and steady manner, with one hundredth of a grain. When pounded chalk was rammed into this tube, I generally left part of it free, and in that space laid a small piece of lump-chalk (*i*), dressed to a cylinder, with the ends cut flat and smooth, and I usually cut a letter on each end, the more effectually to observe the effects produced by heat upon the chalk; the weight of this piece of chalk being always estimated along with that of the powder contained in the tube. In some experiments, I placed a cover of porcelain on the muzzle of the little tube, (this cover being weighed along with it), in order to provide against the case of ebullition:

ebullition: But as that did not often occur, I seldom took the trouble of this last precaution.

It was now of consequence to protect the tube, thus prepared, from being touched during the experiment, by any substance, above all, by the carbonate of lime, which might adhere to it, and thus confound the appreciation by weight. This was provided for as follows: The small tube (Fig. 23. *ik*), with its pounded carbonate (*k*), and its cylinder of lump-chalk (*i*), was dropt into a large tube of porcelain (*pk*, Fig. 24.). Upon this a fragment of porcelain (*l*), of such a size as not to fall in between the tubes, was laid. Then a cylinder of chalk (*m*) was dressed, so as nearly to fit and fill up the inside of the large tube, one end of it being rudely cut into the form of a cone. This mass being then introduced, with its cylindrical end downwards, was made to press upon the fragment of porcelain (*l*). I then dropped into the space (*n*), between the conical part of this mass and the tube, a set of fragments of chalk, of a size beyond what could possibly fall between the cylindrical part and the tube, and pressed them down with a blunt tool, by which the chalk being at the same time crushed and rammed into the angle, was forced into a mass of some solidity, which effectually prevented any thing from passing between the large mass of chalk and the tube. In practice, I have found this method always to answer, when done with care. I covered the chalk, thus rammed, with a stratum of pounded flint (*o*), and that again with pounded chalk (*p*) firmly rammed. In this manner, I filled the whole of the large tube with alternate layers of flint and chalk; the muzzle being always occupied with chalk, which was easily pressed into a mass of tolerable firmness, and, suffering no change in very low heats, excluded the fusible metal in the first stages of the experiment.

The large tube, thus filled, was placed in the cradle, sometimes with the muzzle upwards, and sometimes the reverse. I

have frequently altered my views as to that part of the arrangement, each mode possessing peculiar advantages and disadvantages. With the muzzle upwards, (as shewn in fig. 24. and 25.) the best security is afforded against the intrusion of the fusible metal; because the air, quitting the air-tube in the working position, occupies the upper part of the barrel; and the fusible metal stands as a liquid (at *q*, fig. 25.) below the muzzle of the tube, so that all communication is cut off, between the liquid metal and the inside of the tube. On the other hand, by this arrangement, the small tube, which is the fiducial part of the apparatus, is placed at a considerable distance from the breech of the barrel, so as either to undergo less heat than the upper part, or to render it necessary that the barrel be thrust high into the muffle.

WITH the muzzle of the large tube downwards, the inner tube is placed (as shewn in fig. 22.), so as still to have its muzzle upwards, and in contact with the breech of the large tube. This has the advantage of placing the small tube near to the breech of the barrel: and though there is here less security against the intrusion of liquid metal, I have found that a point of little consequence; since, when the experiment is a good one, and that the carbonic acid has been well confined, the intrusion seldom takes place in any position. In whichever of the two opposite positions the large tube was placed, a pyrometer was always introduced, so as to lie as near as possible to the small tube. Thus, in the first-mentioned position, the pyrometer was placed immediately below the large tube, and, in the other position, above it; so that, in both cases, it was separated from the carbonate by the thickness only of the two tubes.

MUCH room was unavoidably occupied by this method, which necessarily obliged me to use small quantities of carbonate,

bonate,

bonate, the subject of experiment seldom weighing more than 10 or 12 grains, and in others far less*.

ON the 11th of April 1803, with a barrel of old sable iron having a bore of 0.75 of an inch, I made an experiment in which all these arrangements were put in practice. The large tube contained two small ones; one filled with spar, and the other with chalk. I conceived that the heat had risen to 33°, or somewhat higher. On melting the metals, the cradle was thrown out with considerable violence. The pyrometer, which, in this experiment, had been placed within the barrel, to my astonishment, indicated 64°. Yet all was found. The two little tubes came out quite clean and uncontaminated. The spar had lost 17.0 *per cent.*: The chalk 10.7 *per cent.*: The spar was half sunk down, and run against the side of the little tube: Its surface was shining, its texture spongy, and it was composed of a transparent and jelly-like substance: The chalk was entirely in a state of froth. This experiment extends our power of action, by shewing, that compression, to a considerable degree, can be carried on in so great a heat as 64°. It seems likewise to prove, that, in some of the late experiments with the square barrel, the heat had been much higher than was supposed at the time, from the indication of the pyrometer placed on the breech of the barrel; and that in some of them, particularly in the last, it must have risen at least as high as in the present experiment.

P 2 ON

* I measured the capacity of the air-tubes by means of granulated tin, acting as a fine and equal sand. By comparing the weight of this tin with an equal bulk of water, I found that a cubic inch of it weighed 1330.6 grains, and that each grain of it corresponded to 0.00075 of a cubic inch. From these data I was able, with tolerable accuracy, to gage a tube by weighing the tin required to fill it.

ON the 21st of April 1805, a similar experiment was made with a new barrel, bored in a square bar of old sable, of about two and a half inch in diameter, having its angles merely rounded; the inner tube being filled with chalk. The heat was maintained during several hours, and the furnace allowed to burn out during the night. The barrel had the appearance of soundness, but the metals came off quietly, and the carbonate was entirely calcined, the pyrometer indicating 63° . On examination, and after beating off the smooth and even scale of oxide peculiar to the old sable, the barrel was found to have yielded in its peculiar manner; that is, by the opening of the longitudinal fibres. This experiment, notwithstanding the failure of the barrel, was one of the most interesting I had made, since it afforded proof of complete fusion. The carbonate had boiled over the lips of the little tube, standing, as just described, with its mouth upwards, and had run down to within half an inch of its lower end: most of the substance was in a frothy state, with large round cavities, and a shining surface; in other parts, it was interspersed with angular masses, which have evidently been surrounded by a liquid in which they floated. It was harder, I thought, than marble; giving no effervescence, and not turning red like quicklime in nitric acid, which seemed to have no effect upon it in the lump. It was probably a compound of quicklime with the substance of the tube.

WITH the same barrel repaired, and with others like it, many similar experiments were made at this time with great success; but to mention them in detail, would amount nearly to a repetition of what has been said. I shall take notice of only four of them, which, when compared together, throw much light on the theory of these operations, and likewise seem to establish a very important principle in geology. These
four

four experiments differ from each other only in the heat employed, and in the quantity of air introduced.

THE first of these experiments was made on the 27th of April 1803, in one of the large barrels of old sable, with all the above-mentioned arrangements. The heat had risen, contrary to my intention, to 78° and 79° . The tubes came out uncontaminated with fusible metal, and every thing bore the appearance of soundness. The contents of the little tube, consisting of pounded chalk, and of a small piece of lump-chalk, came out clean, and quite loose, not having adhered to the inside of the tube in the smallest degree. There was a loss of 41 *per cent.*, and the calcination seemed to be complete; the substance, when thrown into nitric acid, turning red, without effervescence at first, though, after lying a few minutes, some bubbles appeared. According to the method followed in all these experiments, and lately described at length, (and shewn in fig. 24. & 25.), the large tube was filled over the small one, with various masses of chalk, some in lump, and some rammed into it in powder; and in the cradle there lay some pieces of chalk, filling up the space, so that in the cradle there was a continued chain of carbonate of four or five inches in length. The substance was found to be less and less calcined, the more it was removed from the breech of the barrel, where the heat was greatest. A small piece of chalk, placed at the distance of half an inch from the small tube, had some saline substance in the heart, surrounded and intermixed with quicklime, distinguished by its dull white. In nitric acid, this substance became red, but effervesced pretty briskly; the effervescence continuing till the whole was dissolved. The next portion of chalk, was in a firm state of limestone; and a lump of chalk in the cradle, was equal in perfection to any marble I have obtained by compression: the two last-mentioned pieces of chalk effervescing with violence in the acid, and shewing

no redness when thrown into it. These facts clearly prove, that the calcination of the contents of the small tube had been internal, owing to the violent heat which had separated its acid from the most heated part of the carbonate, according to the theory already stated. The soundness of the barrel was proved by the complete state of those carbonates which lay in less heated parts. The air-tube in this experiment had a capacity of 0.29, nearly one-third of a cubic inch.

THE second of these experiments was made on the 29th of April, in the same barrel with the last, after it had afforded some good results. The air-tube was reduced to one-third of its former bulk, that is, to one-tenth of a cubic inch. The heat rose to 60°. The barrel was covered externally with a black spongy substance, the constant indication of failure, and a small drop of white metal made its appearance. The cradle was removed without any explosion or hissing. The carbonates were entirely calcined. The barrel had yielded, but had resisted well at first; for, the contents of the little tube were found in a complete state of froth, and running with the porcelain.

THE third experiment was made on the 30th of April, in another similar barrel. Every circumstance was the same as in the two last experiments, only that the air-tube was now reduced to half its last bulk, that is, to one-twentieth of a cubic inch. A pyrometer was placed at each end of the large tube. The uppermost gave 41°, the other only 15°. The contents of the inner tube had lost 16 *per cent.*, and were reduced to a most beautiful state of froth, not very much injured by the internal calcination, and indicating a thinner state of fusion than had appeared.

THE fourth experiment was made on the 2d of May, like the rest in all respects, with a still smaller air-tube, of 0.0318, being less than one-thirtieth of a cubic inch. The upper pyrometer

rometer gave 25° , and the under one 16° : The lowest masses of carbonate were scarcely affected by the heat : The contents of the little tube had lost 2.9 *per cent.* ; both the lump and the pounded chalk were in a fine saline state, and, in several places had run and spread upon the inside of the tube, which I had not expected to see in such a low heat. On the upper surface of the chalk rammed into the little tube, which, after its introduction had been wiped smooth, were a set of white crystals, with shining facettes, large enough to be distinguished by the naked eye, and seeming to rise out of the mass of carbonate. I likewise observed, that the solid mass on which these crystals stood, was uncommonly transparent.

IN these four experiments, the bulk of the included air was successively diminished, and by that means its elasticity increased. The consequence was, that in the first experiment, where that elasticity was the least, the carbonic acid was allowed to separate from the lime, in an early stage of the rising heat, lower than the fusing point of the carbonate, and complete internal calcination was effected. In the second experiment, the elastic force being much greater, calcination was prevented, till the heat rose so high as to occasion the entire fusion of the carbonate, and its action on the tube, before the carbonic acid was set at liberty by the failure of the barrel. In the third experiment, with still greater elastic force, the carbonate was partly constrained, and its fusion accomplished, in a heat between 41° and 15° . In the last experiment, where the force was strongest of all, the carbonate was almost completely protected from decomposition by heat, in consequence of which it crystallized and acted on the tube, in a temperature between 25° and 16° . On the other hand, the efficacy of the carbonic acid as a flux on the lime, and in enabling the carbonate to act as a flux on other bodies, was clearly evinced ; since the first experiment

periment proved, that quicklime by itself, could neither be melted, nor act upon porcelain, even in the violent heat of 79° ; whereas, in the last experiment where the carbonic acid was retained, both of these effects took place in a very low temperature.

V.

Experiments in which Water was employed to increase the Elasticity of the included Air.—Cases of complete Compression.—General Observations.—Some Experiments affording interesting results; in particular, shewing a mutual action between Silix and the Carbonate of Lime.

FINDING that such benefit arose from the increase of elasticity given to the included air in the last-mentioned experiments, by the diminution of its quantity; it now occurred to me, that a suggestion formerly made by Dr KENNEDY, of using water to assist the compressing force, might be followed with advantage: That while sufficient room was allowed for the expansion of the liquid metal, a reacting force of any required amount, might thus be applied to the carbonate. In this view, I adopted the following mode, which, though attended with considerable difficulty in execution, I have often practised with success. The weight of water required to be introduced into the barrel was added to a small piece of chalk or baked clay, previously weighed. The piece was then dropped into a tube of porcelain of about an inch in depth, and covered with pounded chalk, which was firmly rammed upon it. The tube was then placed in the cradle along with the subject of experiment, and the whole was plunged into the fusible metal, previously poured into the barrel, and heated so as merely to render it liquid. The metal being thus suddenly cooled, the

the tube was encased in a solid mass, before the heat had reached the included moisture. The difficulty was to catch the fusible metal at the proper temperature; for when it was so hot as not to fix in a few seconds, by the contact of the cradle and its contents, the water was heard to bubble through the metal and escape. I overcame this difficulty, however, by first heating the breech of the barrel, (containing a sufficient quantity of fusible metal), almost to redness, and then setting it into a vessel full of water, till the temperature had sunk to the proper pitch, which I knew to be the case when the hissing noise produced in the water by the heated barrel ceased; the cradle, during the last stage of this operation, being held close to the muzzle of the barrel, and ready to be thrust into it.

ON the 2d of May, I made my first experiment in this way, using the same air-tube as in the last experiment, which was equal in capacity to one-thirtieth of a cubic inch. Half a grain of water was introduced in the manner just described. The barrel, after an hour of red-heat, was let down by a rope and pulley, which I took care to use in all experiments, in which there was any appearance of danger. All was found. The metals rushed out smartly, and a flash of flame accompanied the discharge. The upper pyrometer gave 24° , and the lower one 14° . The contents of the inner tube had lost less than 1 *per cent.*, strictly 0.84. The carbonate was in a state of good limestone; but the heat had been too feeble: The lower part of the chalk in the little tube was not agglutinated: The chalk round the fragment of pipe-stalk (used to introduce the water), which had been more heated than the pyrometer, and the small rod, which had moulded itself in the boll of the stalk, were in a state of marble.

ON the 4th of May, I made an experiment like the last, but with the addition of 1.05 grains water. After application of heat, the

fire was allowed to burn out till the barrel was black. The metal was discharged irregularly. Towards the end, the inflammable air produced, burnt at the muzzle, with a lambent flame, during some time, arising doubtless from hydrogen gas, more or less pure, produced by the decomposition of the water. The upper pyrometer indicated 36° , and the lower one 19° . The chalk which lay in the outer part of the large tube was in a state of marble. The inner tube was united to the outer one, by a star of fused matter, black at the edges, and spreading all round, surrounding one of the fragments of porcelain which had fallen by accident in between the tubes. The inner tube, with the starry matter adhering to it, but without the coated fragment, seemed to have sustained a loss of 12 per cent., on the original carbonate introduced. But, the substance surrounding the fragment being inappreciable, it was impossible to learn what loss had been really sustained. Examining the little tube, I found its edges clean, no boiling over having taken place. The top of the small lump of chalk had sunk much. When the little tube was broken, its contents gave proof of fusion in some parts, and in others, of the nearest approach to it. A strong action of ebullition had taken place all round, at the contact of the tube with the carbonate: in the heart, the substance had a transparent granular texture, with little or no crystallization. The small piece of lump-chalk was united and blended with the rammed powder, so that they could scarcely be distinguished. In the lower part of the carbonate, where the heat must have been weaker, the rod had acted more feebly on the tube, and was detached from it: here the substance was firm, and was highly marked in the fracture with crystalline facettes. Wherever the carbonate touched the tube, the two substances exhibited, in their mixture, much greater proofs of fusion than could be found in the pure carbonate. At one place, a stream of this compound had penetrated a rent in the

the

the inner tube, which it had filled completely, constituting a real vein, like those of the mineral kingdom: which is still distinctly to be seen in the specimen. It had then spread itself upon the outside of the inner tube, to the extent of half an inch in diameter, and had enveloped the fragment of porcelain already mentioned. When pieces of the compound were thrown into nitric acid, some effervesced, and some not.

I REPEATED this experiment on the same day, with two grains of water. The furnace being previously hot; I continued the fire during one half-hour with the muffle open, and another with a cover upon it. I then let the barrel down by means of the pulley. The appearance of a large longitudinal rent, made me at first conceive that the experiment was lost, and the barrel destroyed: The barrel was visibly swelled, and in swelling had burst the crust of smooth oxide with which it was surrounded; at the same time, no exudation of metal had happened, and all was found. The metals were thrown out with more suddenness and violence than in any former experiment, but the rod remained in its place, being secured by a cord. The upper pyrometer gave 27° , the lower 23° . The contents of the inner tube had lost 1.5 *per cent.* The upper end of the little lump of chalk, was rounded and glazed by fusion; and the letter which I have been in the habit of cutting on these small pieces, in order to trace the degree of action upon them, was thus quite obliterated. On the lower end of the same lump, the letter is still visible. Both the lump and the rammed chalk were in a good semitransparent state, shining a little in the fracture, but with no good facettes, and no where appearing to have acted on the tube. This last circumstance is of consequence, since it seems to shew, that this very remarkable action of heat, under compression, was performed without the assistance of the substance of the tube, by which, in many other

Q 2

experiments,

experiments, a considerable additional fusibility has been communicated to the carbonate.

THESE experiments, and many others made about the same time, with the same success, clearly prove the efficacy of water in assisting the compression; and results approaching to these in quality, obtained, in some cases, by means of a very small air-tube, shew that the influence of water on this occasion has been merely mechanical.

DURING the following summer and autumn 1803, I was occupied with a different branch of this subject, which I shall soon have occasion to mention.

IN the early part of last year, 1804, I again resumed the sort of experiments lately described, having in view principally to accomplish absolute compression, in complete imitation of the natural process. In this pursuit, I did not confine myself to water, but made use of various other volatile substances, in order to assist compression; namely, carbonate of ammonia, nitrate of ammonia, gunpowder, and paper impregnated with nitre. With these I obtained some good results, but none such as to induce me to prefer any of these compressors to water. Indeed, I am convinced, that water is superior to them all. I found, in several experiments, made with a simple air-tube, without any artificial compressor, in which a very low red-heat had been applied, that the carbonate lost one or one and a half *per cent.* Now, as this must have happened in a temperature scarcely capable of inflaming gunpowder, it is clear, that such loss would not have been prevented by its presence: whereas water, beginning far below redness to assume a gaseous form, will effectually resist any calcination, in low as well as in high heats. And as the quantity of water can very easily be regulated by weight, its employment for this purpose seems liable to no objection.

ON

ON the 2d of January 1804, I made an experiment with marble and chalk, with the addition of 1.1 grain of water. I aimed at a low heat, and the pyrometer, though a little broken, seemed clearly to indicate 22° . Unluckily, the muzzle of the large tube, which was closed as usual with chalk, was placed uppermost, and exposed to the strongest heat. I found it rounded by fusion, and in a frothy state. The little tube came out very clean, and was so nearly of the same weight as when put in, that its contents had lost but 0.074 *per cent.* of the weight of the original carbonate. The marble was but feebly agglutinated, but the chalk was in a state of firm limestone, though it must have undergone a heat under 22° , or that of melting silver. This experiment is certainly a most remarkable one, since a heat has been applied, in which the chalk has been changed to hard limestone, with a loss less than the 1000th part of its weight, (exactly $\frac{1}{1337}$); while, under the same circumstances of pressure, though probably with more heat, some of the same substance had been brought to fusion. What loss of weight this fused part sustained, cannot be known.

ON the 4th of January, a similar experiment was made, likewise with 1.1 grain of water. The discharge of the metal was accompanied with a flash of flame. The pyrometer indicated 26° . The little tube came out quite clean. Its contents had been reduced from 14.53 to 14.46, difference 0.07 grains, being 0.47 *per cent.* on the original carbonate, less than one two-hundredth part of the original weight, (exactly $\frac{1}{214}$). The chalk was in a state of firm saline marble, but with no unusual qualities.

THESE two last experiments are rendered still more interesting, by another set which I made soon after, which shewed, that one essential precaution in a point of such nicety had been neglected, in not previously drying the carbonate. In several trials made in the latter end of the same month,

I found, that chalk exposed to a heat above that of boiling water, but quite short of redness, lost 0.34 *per cent.*; and in another similar trial, 0.46 *per cent.* Now, this loss of weight equals within 0.01 *per cent.* the loss in the last-mentioned experiment, that being 0.47; and far surpasses that of the last but one, which was but 0.074. There is good reason, therefore, to believe, that had the carbonate, in these two last experiments, been previously dried, it would have been found during compression to have undergone no loss.

THE result of many of the experiments lately mentioned, seems fully to explain the perplexing discordance between my experiments with porcelain tubes, and those made in barrels of iron. With the porcelain tubes, I never could succeed in a heat above 28°, or even quite up to it; yet the results were often excellent. Whereas, the iron-barrels have currently stood firm in heats of 41° or 51°, and have reached even to 70° or 80° without injury. At the same time, the results, even in those high heats, were often inferior, in point of fusion, to those obtained by low heats in porcelain. The reason of this now plainly appears. In the iron-barrels it has always been considered as necessary to use an air-tube, in consequence of which, some of the carbonic acid has been separated from the earthy basis by internal calcination: what carbonic acid remained, has been more forcibly attracted, according to M. BERTHOLLET'S principle, and, of course, more easily compressed, than when of quantity sufficient to saturate the lime: but, owing to the diminished quantity of the acid, the compound has become less fusible than in the natural state, and, of course, has undergone a higher heat with less effect. The introduction of water, by furnishing a reacting force, has produced a state of things similar to that in the porcelain tubes; the carbonate sustaining little or no loss of weight,

weight, and the compound retaining its fusibility in low heats*.

IN the early part of 1804, some experiments were made with barrels, which I wished to try, with a view to another series of experiments. The results were too interesting to be passed over; for, though the carbonic acid in them was far from being completely constrained, they afforded some of the finest examples I had obtained, of the fusion of the carbonate, and of its union with filix.

ON the 13th of February, an experiment was made with pounded oyster-shell, in a heat of 33° , without any water being introduced to assist compression. The loss was apparently of 12 *per cent*. The substance of the shell had evidently been in viscid fusion: it was porous, semitransparent, shining in surface and fracture; in most parts with the gloss of fusion, in many others with facettes of crystallization. The little tube had been set with its muzzle upwards; over it, as usual, lay a fragment of porcelain, and on that a round mass of chalk. At the contact of the porcelain and the chalk, they had run together, and the chalk had been evidently in a very soft state; for, resting with its weight on the porcelain, this last had been pressed into the substance of the chalk, deeper than its own breadth, a rim of chalk being visible without the surface of the porcelain; just as when the round end of a knife is pressed upon

* The retentive power here ascribed to the porcelain tubes, seems not to accord with what was formerly mentioned, of the carbonic acid having been driven through the substance of the tube. But the loss by this means has probably been so small, that the native properties of the carbonate have not been sensibly changed. Or, perhaps, this penetrability may not be so universal as I have been induced to think, by having met with it in all the cases which I tried. In this doubt, I strenuously recommend a further examination of this subject to gentlemen who have easy access to such porcelains as that of Dresden or of Seve.

upon a piece of soft butter. The carbonate had spread very much on the inside of the tube, and had risen round its lip, as some salts rise from their solution in water. In this manner, a small quantity of the carbonate had reached the outer tube, and had adhered to it. The black colour frequently mentioned as accompanying the union of the carbonates with the porcelain, is here very remarkable.

ON the 26th of February, I made an experiment, in which the carbonate was not weighed, and no foreign substance was introduced to assist the compression. The temperature was 46° . The pyrometer had been affected by the contact of a piece of chalk, with which it had united; and some of the carbonate must have penetrated the substance of the pyrometer, since this last had visibly yielded to pressure, as appeared by a swelling near the contact. I observed in these experiments, that the carbonate had a powerful action on the tubes of Cornish clay, more than on the pounded flint. Perhaps it has a peculiar affinity for argil, and this may lead to important consequences. The chalk had visibly first shrunk upon itself, so as to be detached from the sides, and had then begun to run by successive portions, so as still to leave a pillar in the middle, very irregularly worn away; indicating a successive liquefaction, like that of ice, not the yielding of a mass softening all at once.

ON the 28th of February, I made an experiment with oyster-shell unweighed, finely ground, and passed through the closest sieves. The pyrometer gave 40° . The piece of chalk below it had been so soft, as to sink to the depth of half an inch into the mouth of the iron air-tube, taking its impression completely. A small part of this lump was contaminated with iron, but the rest was in a fine state. The tube had a rent in it, through which the carbonate, united with the matter of the tube, had flowed in two or three places. The shell

shell had shrunk upon itself, so as to stand detached from the sides, and bore very strong marks of fusion. The external surface was quite smooth, and shining like an enamel. The internal part consisted of a mixture of large bubbles and solid parts: the inside of the bubbles had a lustre much superior to that of the outside, and equal to that of glass. The general mass was semitransparent; but small parts were visible by the lens, which were completely transparent and colourless. In several places this smooth surface had crystallized, so as to present brilliant facettes, steadily shining in certain aspects. I observed one of these facettes on the inside of an air-bubble, in which it interrupted the spherical form as if the little sphere had been pressed inwards at that spot, by the contact of a plane surface. In some chalk near the mouth of the large tube, which lay upon a stratum of filex, another very interesting circumstance occurred. Connected with its lower end, a substance was visible, which had undoubtedly resulted from the union of the carbonate with the filex. This substance was white and semitransparent, and bore the appearance of chalcedony. The mass of chalk having attached itself to that above it, had shrunk upwards, leaving an interval between it and the filex, and carrying some of the compound up with it. From thence this last had been in the act of dropping in a viscid state of fusion, as evidently appeared when the specimen was entire; having a stalactite and stalagmite corresponding accurately to each other. Unluckily I broke off the stalactite, but the stalagmite continues entire, in the form of a little cone. This new substance effervesced in acid, but not briskly. I watched its entire solution; a set of light clouds remained undissolved, and probably some jelly was formed; for I observed, that a series of air-bubbles remained in the form of the fragment, and moved together without any visible connection; thus seeming to indicate a chemical union be-

tween the filex and the carbonate. The shell, fused in the experiment, dissolved entirely in the acid, with violent effervescence.

IN the three last experiments, and in several others made at the same time, the carbonate had not been weighed; but no water being introduced to assist the compression, it is probable there was much loss by internal calcination; and owing doubtless to this, the carbonates have crumbled almost entirely to dust, while the compounds which they had formed with filex remain entire.

ON the 13th of March, I made a similar experiment, in which, besides some pounded oyster-shell, I introduced a mixture of chalk, with 10 *per cent.* of filex intermixed, and ground together in a mortar with water, in a state of cream, and then well dried. The contents of the tube when opened, were discharged with such violence, that the tube was broken to pieces; but I found a lump of chalk, then in a state of white marble, welded to the compound; which last, in its fracture, shewed that irregular black colour, interspersed roughly through a crystalline mass, that belongs to the alpine marbles, particularly to the kind called at Rome *Cipolline*. It was very hard and firm; I think unusually so. It effervesced constantly to the last atom, in diluted nitric acid, but much more sluggishly than the marble made of pure chalk. A cloudiness appeared pervading all the liquid. When the effervescence was over, a series of bubbles continued during the whole day in the acid, without any disposition to burst, or rise to the surface. After standing all next day and night, they maintained their station; and the solution being stirred, was found to be entirely agglutinated into a transparent jelly, breaking with sharp angles. This experiment affords a direct and positive proof of a chemical union having taken place between the carbonate and filex.

VI.

Experiments made in Platina,—with Spar,—with Shells,—and with Carbonate of Lime of undoubted purity.

SINCE I had the honour of laying before this Society a short sketch of the foregoing experiments, on the 30th of August last (1804), many chemists and mineralogists of eminence have favoured me with some observations on the subject, and have suggested doubts which I am anxious to remove. It has been suggested, that the fusibility of the carbonates may have been the consequence of a mixture of other substances, either originally existing in the natural carbonate, or added to it by the contact of the porcelain tube.

WITH regard to the first of these surmises, I beg leave to observe, that, granting this cause of fusion to have been the real one, a material point, perhaps all that is strictly necessary in order to maintain this part of the Huttonian Theory, was nevertheless gained. For, granting that our carbonates were impure, and that their impurity rendered them fusible, still the same is true of almost every natural carbonate; so that our experiments were, in that respect, conformable to nature. And as to the other surmise, it has been shewn, by comparing together a varied series of experiments, that the mutual action between the lime and the porcelain was occasioned entirely by the presence of the carbonic acid, since, when it was absent, no action of this kind took place. The fusion of our carbonates cannot, therefore, be ascribed to the porcelain.

BEING convinced, however, by many observations, that the fusibility of the carbonate did not depend upon impurity,

I have exerted myself to remove, by fresh experiments, every doubt that has arisen on the subject. In order to guard against natural impurities, I have applied to such of my friends as have turned their attention to chemical analysis, (a branch of the science to which I have never attended,) to furnish me with carbonate of lime of undoubted purity. To obviate the contamination arising from the contact of the porcelain tubes, I determined to confine the subject of experiment in some substance which had no disposition to unite with the carbonate. I first tried charcoal, but found it very troublesome, owing to its irregular absorption of water and air.

I THEN turned my thoughts to the construction of tubes or cups of platina for that purpose. Being unable readily to procure proper solid vessels of this substance, I made use of thin laminated plates, formed into cups. My first method was, to fold the plate exactly as we do blotting-paper to form a filter (Fig. 26.); this produced a cup capable of holding the thinnest liquid; and being covered with a lid, formed of a similar thin plate, bent at the edges, so as to overlap considerably (Fig. 28.), the carbonate it contained was secured on all sides from the contact of the porcelain tube within which it was placed. Another convenient device likewise occurred: I wrapt a piece of the plate of platina round a cylinder, so as to form a tube, each end of which was closed by a cover like that just described (Fig. 27. and 29). (In figure 26. and 27. these cups are represented upon a large scale, and in 28. and 29. nearly of their actual size). This last construction had the advantage of containing eight or nine grains of carbonate, whereas the other would only hold about a grain and a half. On the other hand, it was not fit to retain a thin liquid; but, in most cases, that circumstance was of no consequence; and I foresaw that the carbonates could not
thus

thus escape without proving the main point under consideration, namely, their fusion.

THE rest of the apparatus was arranged in all respects as formerly described; the same precautions being taken to defend the platina vessel as had been used with the inner tubes of porcelain.

IN this manner I have made a number of experiments during this spring and summer, the result of which is highly satisfactory. They prove, in the first place, the propriety of the observations which led to this trial, by shewing, that the pure carbonate, thus defended from any contamination, is decidedly more refractory than chalk; since, in many experiments, the chalk has been reduced to a state of marble, while the pure carbonate, confined in the platina vessel, has been but very feebly acted upon, having only acquired the induration of a sandstone.

IN other experiments, however, I have been more successful, having obtained some results, worthy, I think, of the attention of this Society, and which I shall now submit to their inspection. The specimens are all inclosed, for safety, in glass tubes, and supported on little stands of wax, (fig. 31, 32, 33.). The specimens have, in general, been removed from the cup or tube of platina in which they were formed, these devices having the advantage of securing both the vessel and its contents, by enabling us to unwrap the folds without violence; whereas, in a solid cup or tube, it would have been difficult, after the experiment, to avoid the destruction either of the vessel or its contents, or both.

APRIL 16. 1805.—An experiment was made with pure calcareous spar from St Gothard, remarkably transparent, and having a strong double refraction. A temperature of 40° was applied; but owing to some accident, the weight was not known. The conical cup came out clean and entire, filled

not

not quite to the brim with a yellowish-grey substance, having a shining surface, with longitudinal streaks, as we sometimes see on glass. This surface was here and there interrupted by little white tufts or protuberances, disposed irregularly. On the ledge of the cup, formed by the ends of the folded platina, were several globular drops like minute pearls, visible to the naked eye, the number of which amounted to sixteen. These seem to have been formed by the entire fusion of what carbonate happened to lie on the ledge, or had been entangled amongst the extremities of the folds, drawing itself together, and uniting in drops; as we see when any substance melts under the blowpipe. This result is preserved entire, without deranging the tube. I am sorry to find that it has begun to fall to decay, in consequence, no doubt, of too great a loss of its carbonic acid. But the globules do not seem as yet to have suffered any injury.

APRIL 25.—The same spar was used, with two grains of water, and a heat of 33° . I have reason to suspect, however, that, in this and several other experiments made at this time, the metal into which the cradle was plunged, on first introduction into the barrel, had been too hot, so as to drive off the water. There was a loss of 6.4 *per cent.* The result lay in the cup without any appearance of frothing or swelling. The surface was of a clean white, but rough, having in one corner a space shining like glass. The cup being unwrapped, the substance was obtained sound and entire: where it had moulded itself on the platina, it had a small degree of lustre, with the irregular semitransparency of saline marble: when broken, it preserved that character more completely than in any result hitherto obtained; the fracture being very irregular and angular, and shining with facettes in various directions. I much regret that this beautiful specimen

no longer exists, having crumbled entirely to pieces, notwithstanding all the care I took to inclose it with glass and wax.

APRIL 26. - An experiment was made with some carbonate of lime, purified by my friend Sir GEORGE MACKENZIE. Two grains of water were introduced, but were lost, I suspect, as in the last case. The heat applied was 32° . The loss of weight was 10.6 *per cent.* Yet, though made but one day after the last-mentioned specimen, it remains as fresh and entire as at first, and promises to continue unchanged. The external surface, as seen on removing the lid of the conical cup, was found to shine all over like glass, except round the edges, which were fringed with a series of white and rough sphericles, one set of which advanced, at one spot, near to the centre. The shining surface was composed of planes, which formed obtuse angles together, and had their surface striated; the striæ bearing every appearance of a crystalline arrangement. When freed from the cup, as before, the substance moulded on the platina was found to have assumed a fine pearly surface. Some large air-bubbles appeared, which had adhered to the cup, and were laid open by its removal, whose internal surface had a beautiful lustre, and was full of striæ like the outward surface. The mass is remarkable for semitransparency, as seen particularly where the air-bubbles diminish its thickness: a small part of the mass being broken at one end, shews an internal saline structure.

APRIL 29. — A cup of platina was filled with several large pieces of a periwinkle* shell, the sharp point of the spiral being made to stand upright in the cup, (fig. 30.). A heat of 30° was applied, and no water was introduced. The carbonate lost no less than 16 *per cent.* The shell, particularly

* Turbo terebra, LIN.

the sharp end of the periwinkle, retained its original shape in a great measure, so as to be quite discernible; but the whole was glazed over with a truly vitreous lustre. This glaze covered, at one place, a fragment of the shell which had been originally loose, and had welded the two together. All the angles are rounded by this vitrification; the space between the entire shell and the fragment being filled, and the angles of their meeting rounded, with this shining substance. The colour is a pale blue, contrasted, in the same little glass, with a natural piece of periwinkle, which is of a reddish-yellow. One of the fragments had adhered to the lid, and had been converted into a complete drop, of the size of a mustard-seed. It is fixed on the wax (at *b*), along with the other specimens of the experiment (fig. 32.). This result shews, as yet, no sign of decay, notwithstanding so great a loss of weight.

THE last experiment was repeated on the same day, and prepared in the same manner, with large fragments of shell, and the point of the periwinkle standing up in the cup. A heat of 34° was applied; a loss took place of 13° *per cent*. All the original form had disappeared, the carbonate lying in the cup as a complete liquid, with a concave surface, which did not shine, but was studded all over with the white sphericles or tufts, like those seen in the former results, without any space between them. When detached from the cup, the surface moulded on the platina, was white and pearly, with a slight gloss. The mass was quite solid; no vestige whatever appearing, of the original form of the fragments, (fig. 33.). A small piece, broken off near the apex of the cone, shewed the internal structure to be quite saline. In the act of arranging the specimen on its stand, another piece came off in a new direction, which presented to view the most perfect crystalline arrangement: the shining plane extended across the whole specimen, and was more than the tenth of an inch in all directions. This fracture, likewise,

likewise, shewed the entire internal solidity of the mass. Unfortunately, this specimen has suffered much by the same decay to which all of them are subject which have lost any considerable weight. The part next the outward surface alone remains entire. I have never been able to explain, in a satisfactory manner, this difference of durability; the last-mentioned result having lost more in proportion to its weight than this.

ABOUT the beginning of June, I received from Mr HATCHETT some pure carbonate of lime, which he was so good as to prepare, with a view to my experiments; and I have been constantly employed with it till within these few days.

My first experiments with this substance were peculiarly unfortunate, and it seemed to be less easily acted upon than any substance of the kind I had tried. Its extreme purity, no doubt, contributed much to this, though another circumstance had likewise had some effect. The powder, owing to a crystallization which had taken place on its precipitation, was very coarse, and little susceptible of close ramming; the particles, therefore, had less advantage than when a fine powder is used, in acting upon each other, and I did not choose to run any risk of contamination, by reducing the substance to a finer powder. Whatever be the cause, it is certain, that in many experiments in which the chalk was changed to marble, this substance remained in a loose and brittle state, though consisting generally of clear and shining particles. I at last, however, succeeded in obtaining some very good results with this carbonate.

IN an experiment made with it on the 18th of June, in a strong heat, I obtained a very firm mass with a saline fracture, moulded in several places on the platina, which was now used in the cylindrical form. On the 23d, in a similar experiment, the barrel failed, and the subject of experiment was found in an entire state of froth, proving its former fluidity.

ON the 25th, in a similar experiment, a heat of 64° was applied without any water within the barrel. The platina tube, (having been contaminated in a former experiment with some fusible metal), melted, and the carbonate retaining its cylindrical shape, had fallen through it, so as to touch the piece of porcelain which had been placed next to the platina tube. At the point of contact, the two had run together, as a hot iron runs when touched by sulphur. The carbonate itself was very transparent, resembling a piece of snow in the act of melting.

ON the 26th of June, I made an experiment with this carbonate, which afforded a beautiful result. One grain of water was introduced with great care; yet there was a loss of 6.5 per cent., and the result has fallen to decay. The pyrometer indicated 43° . On the outside of the platina cylinder, and on one of the lids, were seen a set of globules, like pearls, as once before obtained, denoting perfect fusion. When the upper lid was removed, the substance was found to have sunk almost out of sight, and had assumed a form not easily described. (I have endeavoured to represent it in fig. 31. by an ideal section of the platina-tube and its contents, made through the axis of the cylinder). The powder, first shrinking upon itself in the act of agglutination, had formed a cylindrical rod, a remnant of which (*abc*) stood up in the middle of the tube. By the continued action of heat, the summit of the rod (at *a*) had been rounded in fusion, and the mass being now softened, had sunk by its weight, and spread below, so as to mould itself in the tube, and fill its lower part completely (*dfge*). At the same time, the viscid fluid adhering to the sides (at *e* and *d*), while the middle part was sinking, had been in part left behind, and in part drawn out into, a thin but tapering shape, united by a curved surface (at *b* and *c*) to the middle rod. When the platina tube was unwrapped, the thin edges (at *e* and *d*) were preserved all round, and in a state

state of beautiful semitransparency. (I have attempted to represent the entire specimen, as it stood on its cone of wax, in fig. 34.) The carbonate, when moulded on the platina, had a clean pearly whiteness, with a saline appearance externally, and in the sun, shone with facettes. Its surface was interrupted by a few scattered air-bubbles, which had lain against the tube. The intervening substance was unusually compact and hard under the knife. The whole surface (*ebacd*, fig. 31.), and the inside of the air-bubbles, had a vitreous lustre. Thus, every thing denoted a state of viscid fluidity, like that of honey.

THESE last experiments seem to obviate every doubt that remained with respect to the fusibility of the purest carbonate, without the assistance of any foreign substance.

VII.

Measurement of the Force required to constrain the Carbonic Acid.—Apparatus with the Muzzle of the Barrel upwards, and the weight acting by a long Lever.—Apparatus with the Muzzle downwards.—Apparatus with Weight acting directly on the barrel.—Comparison of various results.

IN order to determine, within certain limits at least, what force had been exerted in the foregoing experiments, and what was necessary to ensure their success, I made a number of experiments, in a mode nearly allied to that followed by Count RUMFORD, in measuring the explosive force of gunpowder.

I BEGAN to use the following simple apparatus in June 1803. I took one of the barrels, made as above described, for the purpose of compression, having a bore of 0.75 of an
S 2
inch,

inch *, and dressed its muzzle to a sharp edge. To this barrel was firmly screwed a collar of iron (*aa*, fig. 36.) placed at a distance of about three inches from the muzzle, having two strong bars (*bb*) projecting at right angles to the barrel, and dressed square. The barrel, thus prepared, was introduced, with its breech downwards, into the vertical muffle (fig. 35.); its length being so adjusted, that its breech should be placed in the strongest heat; the two projecting bars above described, resting on two other bars (*cc*, fig. 35.) laid upon the furnace to receive them; one upon each side of the muffle. Into the barrel, so placed, was introduced a cradle, containing carbonate, with all the arrangements formerly mentioned; the rod connected with it being of such length, as just to lie within the muzzle of the barrel. The liquid metal was then poured in till it filled the barrel, and stood at the muzzle with a convex surface; a cylinder of iron, of about an inch in diameter, and half an inch thick, was laid on the muzzle (fig. 35. and 37.), and to it a compressing weight was instantly applied. This was first done by the pressure of a bar of iron (*de*, fig. 35.), three feet in length, introduced loosely into a hole (*d*), made for the purpose in the wall against which the furnace stood; the distance between this hole and the barrel being one foot. A weight was then suspended at the extremity of the bar (*e*), and thus a compressing force was applied, equal to three times that weight. In the course of practice, a cylinder of lead was substituted for that of iron, and a piece of leather was placed between it and the muzzle of the barrel, which last being dressed to a pretty sharp edge, made an impression in the lead: to assist this effect, one smart blow of a hammer was struck upon the bar, directly over the barrel, as soon as the weight had been hung on.

It.

* This was the size of barrel used in all the following experiments, where the fact is not otherwise expressed.

It was essential, in this mode of operation, that the whole of the metal should continue in a liquid state during the action of heat; but when I was satisfied as to its intensity and duration, I congealed the metal, either by extinguishing the furnace entirely, or by pouring water on the barrel. As soon as the heat began to act, drops of metal were seen to force themselves between the barrel and the leather, following each other with more or less rapidity, according to circumstances. In some experiments, there was little exudation; but few of them were entirely free from it. To save the metal thus extruded, I placed a black-lead crucible, having its bottom perforated, round the barrel, and luted close to it, (fig. 37.); some sand being laid in this crucible, the metal was collected on its surface. On some occasions, a sound of ebullition was heard during the action of heat; but this was a certain sign of failure.

THE results of the most important of these experiments, have been reduced to a common standard in the second table placed in the Appendix; to which reference is made by the following numbers.

NO. I.—ON the 16th of June 1803, I made an experiment with these arrangements. I had tried to use a weight of 30 lb. producing a pressure of 90 lb., but I found this not sufficient. I then hung on a weight of 1 cwt., or 112 lb.; by which a compressing force was applied of 3 cwt. or 336 lb. Very little metal was seen to escape, and no sound of ebullition was heard. The chalk in the body of the large tube was reduced to quicklime; but what lay in the inner tube was pretty firm, and effervesced to the last. One or two facettes, of good appearance, were likewise found. The contents of the small tube had lost but 2.6 *per cent.*; but there was a small visible intrusion of metal, and the result, by its appearance, indicated a greater loss. I considered this, however, as one point gained; that being the first:

first tolerable compression accomplished by a determinate force. The pyrometer indicated 22° .

THIS experiment was repeated the same day, when a still smaller quantity of metal escaped at the muzzle; but the barrel had given way below, in the manner of those that have yielded for want of sufficient air. Even this result was satisfactory, by shewing that a mechanical power, capable of forcing some of the barrels, could now be commanded. The carbonate in the little tube had lost 20 *per cent.*; but part of it was in a hard and firm state, effervescing to the last.

NO. 2.—ON the 21st June, I made an experiment with another barrel, with the same circumstances. I had left an empty space in the large tube, and had intended to introduce its muzzle downwards, meaning that space to answer as an air-tube; but it was inverted by mistake, and the tube entering with its muzzle upwards, the empty space had of course filled with metal, and thus the experiment was made without any included air. There was no pyrometer used; but the heat was guessed to be about 25° where the subject of experiment lay. The barrel, when opened, was found full of metal, and the cradle being laid flat on the table, a considerable quantity of metal ran from it, which had undoubtedly been lodged in the vacuity of the large tube. When cold, I found that vacuity still empty, with a plating of metal. The tube was very clean to appearance, and, when shaken, its contents were heard to rattle. Above the little tube, and the cylinder of chalk, I had put some borax and sand, with a little pure borax in the middle, and chalk over it. The metal had not penetrated beyond the borax and sand, by a good fortune peculiar to this experiment; the intrusion of metal in this mode of execution, being extremely troublesome. The button of chalk, was found in a state of clean white carbonate, and pretty hard, but without transparency. The little tube

tube was perfectly clean. Its weight with its contents, seemed to have suffered no change from what it had been when first introduced. Attending, however, to the balance with scrupulous nicety, a small preponderance did appear on the side of the weight. This was done away by the addition of the hundredth of a grain to the scale in which the carbonate lay, and an addition of another hundredth produced in it a decided preponderance. Perhaps, had the tube, before its introduction, been examined with the same care, as great a difference might have been detected; and it seems as if there had been no loss, at least not more than one hundredth of a grain, which on 10.95 grains, amounts to 0.0912, say 0.1 per cent. The carbonate was loose in the little tube, and fell out by shaking. It had a yellow colour, and compact appearance, with a stony hardness under the knife, and a stony fracture; but with very slight facettes, and little or no transparency. In some parts of the specimen, a whitish colour seemed to indicate partial calcination. On examining the fracture, I perceived, with the magnifier, a small globule of metal, not visible to the naked eye, quite insulated and single. Possibly the substance may have contained others of the same sort, which may have compensated for a small loss, but there could not be many such, from the general clean appearance of the whole. In the fracture, I saw here and there small round holes, seeming, though imperfectly, to indicate a beginning of ebullition.

I MADE a number of experiments in the same manner, that is to say, with the muzzle of the barrel upwards, in some of which I obtained very satisfactory results; but it was only by chance that the substance escaped the contamination of the fusible metal; which induced me to think of another mode of applying the compressing weight with the muzzle of the barrel downwards, by which I expected to repeat, with a determinate weight, all the experiments formerly made

made in barrels closed by congealed metal ; and that, by making use of an air-tube, the air, rising to the breech, would secure the contents of the tube from any contamination. In this view, the barrel was introduced from below into the muffle with its breech upwards, and retained in that position by means of a hook fixed to the furnace, till the collar was made to press up against the grate, by an iron lever, loaded with a weight, and resting on a support placed in front. In some experiments made in this way, the result was obtained very clean, as had been expected ; but the force had been too feeble, and when it was increased, the furnace yielded upwards by the mechanical strain.

I FOUND it therefore necessary to use a frame of iron, (as in fig. 38. ; the frame being represented separately in fig. 39.), by which the brick-work was relieved from the mechanical strain. This frame consisted of two bars (*ab* and *fe*, figs. 38. and 39.), fixed into the wall, (at *a* and *f*,) passing horizontally under the furnace, one on each side of the muffle, turning downwards at the front, (in *b* and *e*), and meeting at the ground, with a flat bar (*cd*) uniting the whole. In this manner, a kind of stirrup (*bcd*) was formed in front of the furnace, upon the cross bar (*cd*) of which a block of wood (*bb*, fig. 38.), was placed, supporting an edge of iron, upon which the lever rested ; the working end of the lever (*g*) acting upwards. A strain was exerted, by means of the barrel and its collar, against the horizontal bars, (*ab* and *fe*), which was effectually resisted by the wall (at *a* and *f*) at one end of these bars, and by the upright bars (*cb* and *de*) at the other end. In this manner the whole strain was sustained by the frame, and the furnace stood without injury.

THE iron bar, at its working end, was formed into the shape of a cup, (at *g*), and half filled with lead, the smooth surface of which, was applied to the muzzle of the barrel. The lever, too, was lengthened, by joining to the bar of iron, a beam of wood, making

making the whole ten feet in length. In this manner, a pressure upwards was applied to the barrel, equal to the weight of 10 cwt.

IN the former method, in which the barrel stood with its muzzle upwards, the weight was applied while the metal was liquid. In this case, it was necessary to let it previously congeal, otherwise the contents would have run out in placing the barrel in the muffle, and to allow the liquefaction essential to these trials, to be produced by the propagation of heat from the muffle downwards. This method required, therefore, in every case, the use of an air-tube; for without it, the heat acting upon the breech, while the metal at the muzzle was still cold, would infallibly have destroyed the barrel. A great number of these experiments failed, with very considerable waste of the fusible metal, which, on these occasions was nearly all lost. But a few of them succeeded, and afforded very satisfactory results, which I shall now mention.

IN November 1803, some good experiments were made in this way, all with a bore of 0.75, and a pressure of 10 cwt.

NO. 3.—ON the 19th, a good limestone was obtained in an experiment made in a temperature of 21° , with a loss of only 1.1 per cent.

NO. 4.—ON the 22d, in a similar experiment, there was little exudation by the muzzle. The pyrometer gave 31° . The carbonate was in a porous, and almost frothy state.

NO. 5.—IN a second experiment, made the same day, the heat rose to 37° or 41° . The substance bore strong marks of fusion, the upper part having spread on the little tube: the whole was very much shrunk, and run against one side. The mass sparkling and white, and in a very good state.

NO. 6.—ON the 25th, an experiment was made with chalk, and some fragments of snail shell, with about half a grain of water. The heat had risen to near 51° or 49° . The barrel had been

held tight by the beam, but was rent and a little swelled at the breech. The rent was wide, and such as has always appeared in the strongest barrels when they failed. The carbonate was quite calcined, it had boiled over the little tube, and was entirely in a frothy state, with large and distinctly rounded air-holes. The fragments of shell which had occupied the upper part of the little tube, had lost every trace of their original shape in the act of ebullition and fusion.

No. 7.—ON the 26th a similar experiment was made, in which the barrel was thrown open, in spite of this powerful compressing force, with a report like that of a gun, (as I was told, not having been present), and the bar was found in a state of strong vibration. The carbonate was calcined, and somewhat frothy, the heart of one piece of chalk used was in a state of saline marble.

It now occurred to me to work with a compressing force; and no air-tube, trusting, as happened accidentally in one case, that the expansion of the liquid would clear itself by gentle exudation, without injury to the carbonate. In this mode, it was necessary, for reasons lately stated, to place the muzzle upwards. Various trials made thus, at this time, afforded no remarkable results. But I resumed the method, with the following alteration in the application of the weight, on the 27th of April 1804.

I CONCEIVED that some inconvenience might arise from the mode of employing the weight in the former experiments. In them it had been applied at the end of the bar, and its effect propagated along it, so as to press against the barrel at its other extremity. It occurred to me, that the propagation of motion in this way, requiring some sensible time, a considerable quantity of carbonic acid might escape by a sudden eruption, before that propagation had taken effect. I therefore thought, that more effectual work might be done, by
placing

placing a heavy mass, (fig. 40.), so as to act directly and simply upon the muzzle of the barrel; this mass being guided and commanded by means of a powerful lever, (*ab*). For this purpose, I procured an iron roller, weighing 3 cwt. 7 lb., and suspended it over the furnace, to the end of a beam of wood, resting on a support near the furnace, with a long arm guided by a rope (*cc*) and pulley (*d*), by which the weight could be raised or let down at pleasure.

WITH this apparatus I made some tolerable experiments; but I found the weight too light to afford certain and steady results of the best quality. I therefore procured at the foundry a large mass of iron (*f*), intended, I believe, for driving piles, and which, after allowing for the counterpoise of the beam, gave a direct pressure of 8.1 cwt.; and I could, at pleasure, diminish the compressing force, by placing a bucket (*e*) at the extremity of the lever, into which I introduced weights, whose effect on the ultimate great mass, was known by trial. Many barrels failed in these trials: at last, I obtained one of small bore, inch 0.54, which gave two good results on the 22d of June 1804.

No. 8.—WISHING to ascertain the least compressing force by which the carbonate could be effectually constrained in melting heats, I first observed every thing standing firm in a heat of above 20° ; I then gradually threw weights into the bucket, till the compressing force was reduced to 2 cwt. Till then, things continued steady; but, on the pressure being still further diminished, metal began to ooze out at the muzzle, with increasing rapidity. When the pressure was reduced to $1\frac{1}{2}$ cwt. air rushed out with a hissing noise. I then stopped the experiment, by pouring water on the barrel. The piece of chalk had lost 12 per cent. It was white and soft on the outside, but firm and good in the heart.

T. 2
No. 9.

NO. 9.—AN experiment was made with chalk, in a little tube ; to this, one grain of water was added. I had intended to work with 4 cwt. only ; but the barrel was no sooner placed, than an exudation of metal began at the muzzle, owing, doubtless, to the elasticity of the water. I immediately increased the pressure to 8.1 cwt. by removing the weight from the bucket, when the exudation instantly ceased. I continued the fire for three quarters of an hour, during which time no exudation happened ; then all came out remarkably clean, with scarcely any contamination of metal. The loss amounted to 2.58 *per cent.* The substance was tolerably indurated, but had not acquired the character of a complete stone.

IN these two last experiments, the bore being small, a pyrometer could not be admitted.

ON the 5th of July 1804, I made three very satisfactory experiments of this kind, in a barrel with the large bore of 0.75 of an inch.

NO. 10.—WAS made with a compressing force of only 3 cwt. A small eruption at the muzzle being observed, water was thrown on the barrel : the pyrometer gave 21° : the chalk was in a firm state of limestone.

NO. 11.—WITH 4 cwt. The barrel stood without any eruption or exudation, till the heat rose to 25° . There was a loss of 3.6 *per cent.* : the result was superior, in hardness and transparency, to the last, having somewhat of a saline fracture.

NO. 12.—WITH 5 cwt. The result, with a loss of 2.4 *per cent.*, was of a quality superior to any of those lately obtained.

THESE experiments appear to answer the end proposed, of ascertaining the least pressure, and lowest heat, in which limestone can be formed. The results, with various barrels of different sizes, agree tolerably, and tend to confirm each other. The table shews, when we compare numbers 1, 2, 8, 10, 11, 12, That a pressure of 52 atmospheres, or 1700 feet of sea, is capable

capable of forming a limestone in a proper heat : That under 86 atmospheres, answering nearly to 3000 feet, or about half a mile, a complete marble may be formed : and lastly, That with a pressure of 173 atmospheres, or 5700 feet, that is, little more than one mile of sea, the carbonate of lime is made to undergo complete fusion, and to act powerfully on other earths.

VIII.

Formation of Coal.—Accidental occurrence which led me to undertake these Experiments.—Results extracted from a former publication.—Explanation of some difficulties that have been suggested.—The Fibres of Wood in some cases obliterated, and in some preserved under compression.—Resemblance which these Results bear to a series of Natural Substances described by Mr HATCHETT.—These results seem to throw light on the history of Surturbrand.

As I intend, on some future occasion, to resume my experiments with inflammable substances, which I look upon as far from complete, I shall add but a few observations to what I have already laid before this Society, in the sketch I had the honour to read in this place on the 30th of August last.

THE following incidental occurrence led me to enter upon this subject rather prematurely, since I had determined first to satisfy myself with regard to the carbonate of lime.

OBSERVING, in many of the last-mentioned class of experiments, that the elastic matters made their escape between the muzzle of the barrel and the cylinder of lead, I was in the habit, as mentioned above, of placing a piece of leather between the lead and the barrel ; in which position, the heat to which the leather was exposed, was necessarily below that of melting lead.

lead. In an experiment, made on the 28th November 1803, in order to ascertain the power of the machinery, and the quantity of metal driven out by the expansion of the liquid, there being nothing in the barrel but metal, I observed, as soon as the compressing apparatus was removed, (which on this occasion was done while the lower part of the barrel was at its full heat, and the barrel standing brim full of liquid metal,) that all the leather which lay on the outside of the circular muzzle of the barrel, remained, being only a little browned and crumpled by the heat to which it had been exposed. What leather lay within the circle, had disappeared; and, on the surface of the liquid metal, which stood up to the lip of the barrel, I saw large drops, of a shining black liquid, which, on cooling, fixed into a crisp black substance, with a shining fracture, exactly like pitch or pure coal. It burned, though not with flame. While hot, it smelt decidedly of volatile alkali. The important circumstance here, is the different manner in which the heat has acted on the leather, without and within the rim of the barrel. The only difference consisted in compression, to which, therefore, the difference of effect must be ascribed: by its force, the volatile matter of the leather which escaped from the outward parts, had within the rim, been constrained to remain united to the rest of the composition, upon which it had acted as a flux, and the whole together had entered into a liquid state, in a very low heat. Had the pressure been continued till all was cool, these substances must have been retained, producing a real coal.

ON the 24th April 1803, a piece of leather used in a similar manner, (the compressing force being continued, however, till all was cold,) was changed to a substance like glue, owing doubtless to compression, in a heat under that of melting lead.

THESE observations led me to make a series of experiments with animal and vegetable substances, and with coal; the

the result of which I have already laid before the Society. I shall now repeat that communication, as printed in NICHOLSON'S *Journal* for October last (1804).

“ I HAVE likewise made some experiments with coal, treated in the same manner as the carbonate of lime: but I have found it much less tractable; for the bitumen, when heat is applied to it, tends to escape by its simple elasticity, whereas the carbonic acid in marble, is in part retained by the chemical force of quicklime. I succeeded, however, in constraining the bituminous matter of the coal, to a certain degree, in red heats, so as to bring the substance into a complete fusion, and to retain its faculty of burning with flame. But, I could not accomplish this in heats capable of agglutinating the carbonate; for I have found, where I rammed them successively into the same tube, and where the vessel has withstood the expansive force, that the carbonate has been agglutinated into a good limestone, but that the coal has lost about half its weight, together with its power of giving flame when burnt, remaining in a very compact state, with a shining fracture. Although this experiment has not afforded the desired result, it answers another purpose admirably well. It is known, that where a bed of coal is crossed by a dike of whinstone, the coal is found in a peculiar state in the immediate neighbourhood of the whin: the substance in such places being incapable of giving flame, it is distinguished by the name of *blind coal*. Dr. HUTTON has explained this fact, by supposing that the bituminous matter of the coal, has been driven by the local heat of whin, into places of less intensity, where it would probably be retained by distillation. Yet the whole must have been carried on under the action of a pressure capable of constraining the carbonic acid of the calcareous spar, which occurs frequently in such rocks. In the last-mentioned experiment, we have a perfect representation.

tation of the natural fact; since the coal has lost its petroleum, while the chalk in contact with it has retained its carbonic acid.

“ I HAVE made some experiments of the same kind, with vegetable and animal substances. I found their volatility much greater than that of coal, and I was compelled, with them, to work in heats below redness; for, even in the lowest red-heat, they were apt to destroy the apparatus. The animal substance I commonly used was horn, and the vegetable, saw-dust of fir. The horn was incomparably the most fusible and volatile of the two. In a very slight heat, it was converted into a yellow red substance, like oil, which penetrated the clay tubes through and through. In these experiments, I therefore made use of tubes of glass. It was only after a considerable portion of the substance had been separated from the mass, that the remainder assumed the clear black peculiar to coal. In this way I obtained coal, both from saw-dust and from horn, which yielded a bright flame in burning.

“ THE mixture of the two produced a substance having exactly the smell of foot or coal-tar. I am therefore strongly inclined to believe, that animal substance, as well as vegetable, has contributed towards the formation of our bituminous strata. This seems to confirm an opinion, advanced by Mr KEIR, which has been mentioned to me since I made this experiment. I conceive, that the coal which now remains in the world, is but a small portion of the organic matter originally deposited: the most volatile parts have been driven off by the action of heat, before the temperature had risen high enough to bring the surrounding substance into fusion, so as to confine the elastic fluids, and subject them to compression.

“ IN several of these experiments, I found that, when the pressure was not great, when equal, for instance, only to 80 atmospheres, that the horn employed was dissipated entirely, the
glass

glass tube which had contained it being left almost clean: yet undoubtedly, if exposed to heat without compression, and protected from the contact of the atmosphere, the horn would leave a cinder or coak behind it, of matter wholly devoid of volatility. Here, then, it would seem as if the moderate pressure, by keeping the elements of the substance together, had promoted the general volatility, without being strong enough to resist that expansive force, and thus, that the whole had escaped. This result, which I should certainly not have foreseen in theory, may perhaps, account for the absence of coal in situations where its presence might be expected on principles of general analogy.”

SINCE this publication, a very natural question has been put to me. When the inflammable substance has lost weight, or when the whole has been dissipated, in these experiments, what has become of the matter thus driven off?

I MUST own, that to answer this question with perfect confidence, more experiments are required. But, in the course of practice, two circumstances have occurred as likely, in most cases, to have occasioned the loss alluded to. I found in these experiments, particularly with horn, that the chalk, both in powder and in lump, which was used to fill vacuities in the tubes, and to fix them in the cradle, was strongly impregnated with an oily or bituminous matter, giving to the substance the qualities of a stinkstone. I conceive, that the most volatile part of the horn has been conveyed to the chalk, partly in a state of vapour, and partly by boiling over the lips of the glass tube; the whole having been evidently in a state of very thin fluidity. Having, in some cases, found the tube, which had been introduced full of horn, entirely empty after the experiment, I was induced, as above stated, to conceive, that, under pressure, it had acquired a greater general volatility than it had in freedom;

dom; and I find that, in the open fire, horn yields a charcoal equal to 20 *per cent.* of the original weight. But more experiments must be made on this subject.

ANOTHER cause of the loss of weight, lay undoubtedly in the excess of heat employed in most of them, to remove the cradle from the barrel. With inflammable substances, no air-tube was used, and the heats being low, the air lodged in interstices had been sufficient to secure the barrels from destruction, by the expansion of the liquid metal. In this view, likewise, I often used lead, whose expansion in such low heats, I expected to be less than that of the fusible metal. And the lead requiring to melt it, a heat very near to that of redness, the subject of experiment was thus, on removing the cradle, exposed in freedom to a temperature which was comparatively high. But, observing that a great loss was thus occasioned, I returned to the use of the fusible metal, together with my former method of melting it, by plunging the barrel, when removed from the furnace, into a solution of muriate of lime, by which it could only receive a heat of 250° of FAHRENHEIT.

THE effect was remarkable, in the few experiments tried in this way. The horn did not, as in the other experiments, change to a hard black substance, but acquired a semifluid and viscid consistency, with a yellow-red colour, and a very offensive smell. This shews, that the substances which here occasioned both the colour and smell of the results, had been driven off in the other experiments, by the too great heat applied to the substance, when free from compression.

I FOUND that the organization of animal substance was entirely obliterated by a slight action of heat, but that a stronger heat was required to perform the entire fusion of vegetable matter. This, however, was accomplished; and in several experiments, pieces of wood were changed to a jet-black and inflammable substance, generally very porous, in which no
trace

trace could be discovered of the original organization. In others, the vegetable fibres were still visible, and are forced asunder by large and shining air-bubbles.

SINCE the publication of the sketch of my experiments, I have had the pleasure to read Mr HATCHETT's very interesting account of various natural substances, nearly allied to coal; and I could not help being struck with the resemblance which my results bear to them, through all their varieties, as brought into view by that able chemist; that resemblance affording a presumption, that the changes which, with true scientific modesty, he ascribes to an unknown cause, may have resulted from various heats acting under pressure of various force. The substance to which he has given the name of *Retinasphaltum*, seems to agree very nearly with what I have obtained from animal substance, when the barrel was opened by means of low heat. And the specimen of wood entering into fusion, but still retaining the form of its fibres, seems very similar to the intermediate substance of Bovey-coal and *Surturbrand*, which Mr HATCHETT has assimilated to each other. It is well known, that the *surturbrand* of Iceland, consists of the stems of large trees, flattened to thin plates, by some operation of nature hitherto unexplained. But the last-mentioned experiment seems to afford a plausible solution of this puzzling phenomenon.

IN all parts of the globe, we find proofs of slips, and various relative motions, having taken place amongst great masses of rock, whilst they were soft in a certain degree, and which have left unequivocal traces behind them, both in the derangement of the beds of strata, and in a smooth and shining surface, called *slickenside*, produced by the direct friction of one mass on another. During the action of subterranean heat, were a single stratum to occur, containing trees intermixed with animal substances, shell-fish, &c. these trees would be reduced, to a soft and unctuous state, similar to that of the piece of wood

in the last-mentioned experiment, whilst the substance of the contiguous strata retained a considerable degree of firmness. In this state of things, the stratum just mentioned, would very naturally become the scene of a slip, occasioned by the unequal pressure of the surrounding masses. By such a sliding motion, accompanied by great compression, a tree would be flattened, as any substance is ground in a mortar, by the combination of a lateral and direct force. At the same time, the shells along with the trees, would be flattened, like those described by BERGMAN; while those of the same species in the neighbouring limestone-rock, being protected by its inferior fusibility, would retain their natural shape.

IX.

Application of the foregoing results to Geology.—The fire employed in the Huttonian Theory is a modification of that of the Volcanoes.—This modification must take place in a lava previous to its eruption.—An Internal Lava is capable of melting Limestone.—The effects of Volcanic Fire on substances in a subterranean and submarine situation, are the same as those ascribed to Fire in the Huttonian Theory.—Our Strata were once in a similar situation, and then underwent the action of fire.—All the conditions of the Huttonian Theory being thus combined, the formation of all Rocks may be accounted for in a satisfactory manner.—Conclusion.

HAVING investigated, by means of the foregoing experiments, some of the chemical suppositions involved in the Huttonian Theory, and having endeavoured to assign a determinate limit to the power of the agents employed; I shall now apply these results to Geology, and inquire how far the events
supposed

supposed anciently to have taken place, accord with the existing state of our globe.

THE most powerful and essential agent of the Huttonian Theory, is Fire, which I have always looked upon as the same with that of volcanoes, modified by circumstances which must, to a certain degree, take place in every lava previous to its eruption.

THE original source of internal fire is involved in great obscurity; and no sufficient reason occurs to me for deciding whether it proceeds by emanation from some vast central reservoir, or is generated by the local operation of some chemical process. Nor is there any necessity for such a decision: all we need to know is, that internal fire exists, which no one can doubt, who believes in the eruptions of Mount Vesuvius. To require that a man should account for the generation of internal fire, before he is allowed to employ it in geology, is no less absurd than it would be to prevent him from reasoning about the construction of a telescope, till he could explain the nature of the sun, or account for the generation of light*. But while we remain in suspense as to the prime cause of this tremendous agent, many circumstances of importance with regard to it, may fairly become the subjects of observation and discussion.

SOME authors (I conceive through ignorance of the facts) have alleged, that the fire of *Ætna* and *Vesuvius* is merely superficial. But the depth of its action is sufficiently proved, by the great distance to which the eruptive percussions are felt, and still more, by the substances thrown out uninjured by some eruptions

* THIS topic, however, has of late been much urged against us, and an unfair advantage has been taken of what Mr PLAYFAIR has said upon it. What he gave as mere conjecture on a subject of collateral importance, has been argued upon as the basis and fundamental doctrine of the system.

eruptions of Mount Vesuvius. Some of these, as marble and gypsum, are incapable in freedom of resisting the action of fire. We have likewise granite, schistus, gneiss, and stones of every known class, besides many which have never, on any other occasion, been found at the surface of our globe. The circumstance of these substances having been thrown out, unaffected by the fire, proves, that it has proceeded from a source, not only as deep, but deeper, than their native beds; and as they exhibit specimens of every class of minerals, the formation of which we pretend to explain, we need inquire no further into the depth of the Vesuvian fire, which has thus been proved to reach below the range of our speculations.

VOLCANIC fire is subject to perpetual and irregular variations of intensity, and to sudden and violent renewal, after long periods of absolute cessation. These variations and intermissions, are likewise essential attributes of fire as employed by Dr HUTTON; for some geological scenes prove, that the indurating cause has acted repeatedly on the same substance, and that, during the intervals of that action, it had ceased entirely. This circumstance affords a complete answer to an argument lately urged against the Huttonian Theory, founded on the waste of heat which must have taken place, as it is alleged, through the surface. For if, after absolute cessation, a power of renewal exists in nature, the idea of waste by continuance is quite inapplicable.

THE external phenomena of volcanoes are sufficiently well known; but our subject leads us to inquire into their internal actions. This we are enabled to do by means of the foregoing experiments, in so far as the carbonate of lime is concerned.

SOME experiments which I formerly * laid before this Society and the public, combined with those mentioned in this paper,

* *Edinburgh Transactions*, Vol. V. Part I. p. 60—66.

paper, prove, that the feeblest exertions of volcanic fire, are of sufficient intensity to perform the agglutination, and even the entire fusion, of the carbonate of lime, when its carbonic acid is effectually confined by pressure; for though lava, after its fusion, may be made, in our experiments, to congeal into a glass, in a temperature of 16° or 18° of WEDGWOOD, in which temperature the carbonate would scarcely be affected; it must be observed, that a similar congelation is not to be looked for in nature; for the mass, even of the smallest stream of lava, is too great to admit of such rapid cooling. And, in fact, the external part of a lava is not vitreous, but consists of a substance which, as my experiments have proved, must have been congealed in a heat of melting silver, that is, in 22° of WEDGWOOD; while its internal parts bear a character indicating that they congealed in 27° or 28° of the same scale. It follows, that no part of the lava, while it remained liquid, can have been less hot than 22° of WEDGWOOD. Now, this happens to be a heat, in which I have accomplished the entire fusion of the carbonate of lime, under pressure. We must therefore conclude, that the heat of a running lava is always of sufficient intensity to perform the fusion of limestone.

IN every active volcano, a communication must exist between the summit of the mountain and the unexplored region, far below its base, where the lava has been melted, and whence it has been propelled upwards; the liquid lava rising through this internal channel, so as to fill the crater to the brim, and flow over it. On this occasion, the sides of the mountain must undergo a violent hydrostatical pressure outwards, to which they often yield by the formation of a vast rent, through which the lava is discharged in a lateral eruption, and flows in a continued stream sometimes during months. On *Ætna* most of the eruptions are so performed; few lavas flowing from the summit, but generally breaking out laterally, at very elevated stations.

At

At the place of delivery, a quantity of gaseous matter is propelled violently upwards, and, along with it, some liquid lava; which last, falling back again in a spongy state, produces one of those conical hills which we see in great number on the vast sides of Mount *Ætna*, each indicating the discharge of a particular eruption. At the same time, a jet of flame and smoke issues from the main crater, proving the internal communication between it and the lava; this discharge from the summit generally continuing, in a greater or a less degree, during the intervals between eruptions. (Fig. 41. represents an ideal section of Mount *Ætna*; *ab* is the direct channel, and *bc* is a lateral branch).

LET us now attend to the state of the lava within the mountain, during the course of the eruption; and let us suppose, that a fragment of limestone, torn from some stratum below, has been included in the fluid lava, and carried up with it. By the laws of hydrostatics, as each portion of this fluid sustains pressure in proportion to its perpendicular distance below the point of discharge, that pressure must increase with the depth. The specific gravity of solid and compact lava is nearly 2.8; and its weight, when in a liquid state, is probably little different. The table shews, that the carbonic acid of limestone cannot be constrained in heat by a pressure less than that of 1708 feet of sea, which corresponds nearly to 600 feet of liquid lava. As soon, then, as our calcareous mass rose to within 600 feet of the surface, its carbonic acid would quit the lime, and, assuming a gaseous form, would add to the eruptive effervescence. And this change would commonly begin in much greater depths, in consequence of the bubbles of carbonic acid, and other substances in a gaseous form, which, rising with the lava, and through it, would greatly diminish the weight of the column, and would render its pressure on any particular spot extremely variable. With all these irregularities, however, and interruptions, the
pressure

pressure would in all cases, especially where the depth was considerable, far surpass what it would have been under an equal depth of water. Where the depth of the stream, below its point of delivery, amounted, then, to 1708 feet, the pressure, if the heat was not of excessive intensity, would be more than sufficient to constrain the carbonic acid, and our limestone would suffer no calcination, but would enter into fusion; and if the eruption ceased at that moment, would crystallize in cooling along with the lava, and become a nodule of calcareous spar. The mass of lava, containing this nodule, would then constitute a real whinstone, and would belong to the kind called *amygdaloid*. In greater depths still, the pressure would be proportionally increased, till sulphur, and even water, might be constrained; and the carbonate of lime would continue undecomposed in the highest heats.

If, while the lava was in a liquid state, during the eruption or previous to it, a new rent (*de*, fig. 41.), formed in the solid country below the volcano, was met by our stream (at *d*), it is obvious that the lava would flow into the aperture with great rapidity, and fill it to the minutest extremity, there being no air to impede the progress of the liquid. In this manner, a stream of lava might be led from below to approach the bottom of the sea (*ff*), and to come in contact with a bed of loose shells (*gg*), lying on that bottom, but covered with beds of clay, interstratified, as usually occurs, with beds of sand, and other beds of shells. The first effect of heat would be to drive off the moisture of the lowest shell-bed, in a state of vapour; which, rising till it got beyond the reach of the heat, would be condensed into water, producing a slight motion of ebullition, like that of a vessel of water, when it begins to boil, and when it is said to simmer. The beds of clay and sand might thus undergo some heaving and partial derangement, but would still possess the power of stopping, or of very much im-

peding, the descent of water from the sea above; so that the water which had been driven from the shells at the bottom, would not return to them, or would return but slowly; and they would be exposed dry to the action of heat*.

IN this case, one of two things would inevitably happen. Either the carbonic acid of the shells would be driven off by the heat, producing an incondensable elastic fluid, which, heaving up or penetrating the superincumbent beds, would force its way to the surface of the sea, and produce a submarine eruption, as has happened at Santorini and elsewhere; or the volatility of the carbonic acid would be repressed by the weight of the superincumbent water (*kk*), and the shell-bed, being softened or fused by the action of heat, would be converted into a stratum of limestone.

THE foregoing experiments enable us to decide in any particular case, which of these two events must take place, when the heat of the lava and the depth of the sea are known.

THE table shews, that under a sea no deeper than 1708 feet, near one-third of a mile, a limestone would be formed by proper heat; and that, in a depth of little more than one mile, it would enter into entire fusion. Now, the common soundings of mariners extend to 200 fathoms, or 1200 feet. Lord MULGRAVE † found bottom at 4680 feet, or nearly nine-tenths of a mile; and Captain ELLIS let down a sea-gage to the depth of 5346 feet ‡. It thus appears,

that

* THIS situation of things, is similar to what happens when small-coal is moistened, in order to make it cake. The dust, drenched with water, is laid upon the fire, and remains long wet, while the heat below suffers little or no abatement.

† *Voyage towards the North Pole*, p. 142.

‡ *Philosophical Transactions*, 1751, p. 212.

that at the bottom of a sea, which would be founded by a line much less than double of the usual length, and less than half the depth of that founded by Lord MULGRAVE, limestone might be formed by heat; and that, at the depth reached by Captain ELLIS, the entire fusion would be accomplished, if the bed of shells were touched by a lava at the extremity of its course, when its heat was lowest. Were the heat of the lava greater, a greater depth of sea would, of course, be requisite to constrain the carbonic acid effectually; and future experiments may determine what depth is required to co-operate with any given temperature. It is enough for our present purpose to have shewn, that the result is possible in any case, and to have circumscribed the necessary force of these agents within moderate limits. At the same time it must be observed, that we have been far from stretching the known facts; for when we compare the small extent of sea in which any soundings can be found, with that of the vast unfathomed ocean, it is obvious, that in assuming a depth of one mile or two, we fall very short of the medium. M. DE LA PLACE, reasoning from the phenomena of the tides, states it as highly probable that this medium is not less than eleven English miles*.

If a great part or the whole of the superincumbent mass consisted, not of water, but of sand or clay, then the depth requisite to produce these effects would be lessened, in the inverse ratio of the specific gravity. If the above-mentioned occurrence took place under a mass composed of stone firmly bound together by some previous operation of nature, the power of the superincumbent mass, in opposing the escape of

X 2

carbonic

* "On peut donc regarder au moins comme très probable, que la profondeur moyenne de la mer n'est pas au-dessous de quatre lieues." DE LA PLACE, *Hist. de l'Acad. Roy. des Sciences*, année 1776.

carbonic acid, would be very much increased by that union and by the stiffness or tenacity of the substance. We have seen numberless examples of this power in the course of these experiments, in which barrels, both of iron and porcelain, whose thickness did not exceed one-fourth of an inch, have exerted a force superior to the mere weight of a mile of sea. Without supposing that the substance of a rock could in any case act with the same advantage as that of a uniform and connected barrel; it seems obvious that a similar power must, in many cases, have been exerted to a certain degree.

WE know of many calcareous masses which, at this moment, are exposed to a pressure more than sufficient to accomplish their entire fusion. The mountain of Saleve, near Geneva, is 500 French fathoms, or nearly 3250 English feet, in height, from its base to its summit. Its mass consists of beds, lying nearly horizontal, of limestone filled with shells. Independently, then, of the tenacity of the mass, and taking into account its mere weight, the lowest bed of this mountain, must, at this moment, sustain a pressure of 3250 feet of limestone, the specific gravity of which is about 2.65. This pressure, therefore, is equal to that of 8612 feet of water, being nearly a mile and a half of sea, which is much more than adequate, as we have shewn, to accomplish the entire fusion of the carbonate, on the application of proper heat. Now, were an emanation from a volcano, to rise up under Saleve, and to penetrate upwards to its base, and stop there; the limestone to which the lava approached, would inevitably be softened, without being calcined, and, as the heat retired, would crystallize into a saline marble.

SOME other circumstances, relating to this subject, are very deserving of notice, and enable us still further to compare the ancient and modern operations of fire.

It appears, at first sight, that a lava having once penetrated the side of a mountain, all subsequent lavas should continue, as water would infallibly do, to flow through the same aperture. But there is a material difference in the two cases. As soon as the lava has ceased to flow, and the heat has begun to abate, the crevice through which the lava had been passing, remains filled with a substance, which soon agglutinates into a mass, far harder and firmer than the mountain itself. This mass, lying in a crooked bed, and being firmly welded to the sides of the crevice, must oppose a most powerful resistance to any stream tending to pursue the same course. The injury done to the mountain by the formation of the rent, will thus be much more than repaired; and in a subsequent eruption, the lava must force its way through another part of the mountain or through some part of the adjoining country. The action of heat from below, seems in most cases to have kept a channel open through the axis of the mountain, as appears by the smoke and flame which is habitually discharged at the summit during intervals of calm. On many occasions, however, this spiracle seems to have been entirely closed by the consolidation of the lava, so as to suppress all emission. This happened to Vesuvius during the middle ages. All appearance of fire had ceased for five hundred years, and the crater was covered with a forest of ancient oaks, when the volcano opened with fresh vigour in the sixteenth century.

THE eruptive force, capable of overcoming such an obstacle, must be tremendous indeed, and seems in some cases to have blown the volcano itself almost to pieces. It is impossible to see the Mountain of Somma, which, in the form of a crescent, embraces Mount Vesuvius, without being convinced that it is a fragment of a large volcano, nearly concentric with

with the present inner cone, which, in some great eruption, had been destroyed all but this fragment. In our own times, an event of no small magnitude has taken place on the same spot; the inner cone of Vesuvius having undergone so great a change during the eruption in 1794, that it now bears no resemblance to what it was when I saw it in 1785.

THE general or partial stagnation of the internal lavas at the close of each eruption seems, then, to render it necessary, that in every new discharge, the lava should begin by making a violent laceration. And this is probably the cause of those tremendous earthquakes which precede all great eruptions, and which cease as soon as the lava has found a vent. It seems but reasonable to ascribe like effects to like causes, and to believe that the earthquakes which frequently desolate countries not externally volcanic, likewise indicate the protrusion from below of matter in liquid fusion, penetrating the mass of rock;

THE injection of a whinstone-dike into a frail mass of shale and sandstone, must have produced the same effects upon it that the lava has just been stated to produce on the loose beds of volcanic scoria. One stream of liquid whin, having flowed into such an assemblage, must have given it great additional weight and strength: so that a second stream coming like the first, would be opposed by a mass, the laceration of which would produce an earthquake, if it were overcome; or by which, if it resisted, the liquid matter would be compelled to penetrate some weaker mass, perhaps at a great distance from the first. The internal fire being thus compelled perpetually to change the scene of its action, its influence might be carried to an indefinite extent: So that the intermittance in point of time, as well as the versatility in point of place, already remarked as common to the Huttonian and Volcanic fires, are accounted for on our principles.

ples. And it thus appears, that whinstone possesses all the properties which we are led by theory to ascribe to an internal lava.

THIS connection is curiously illustrated by an intermediate case between the results of external and internal-fire, displayed in an actual section of the ancient part of Vesuvius, which occurs in the Mountain of Somma mentioned above. I formerly described this scene in my paper on Whinstone and Lava; and I must beg leave once more to press it upon the notice of the public, as affording to future travellers a most interesting field of geological inquiry.

THE section is seen in the bare vertical cliff, several hundred feet in height, which Somma presents to the view from the little valley, in form of a crescent, which lies between Somma and the interior cone of Vesuvius, called the *Atrio del Cavallo*. (Fig. 42. represents this scene, done from the recollection of what I saw in 1785. *abc* is the interior cone of Vesuvius; *dfg* the mountain of Somma; and *cde* the *Atrio del Cavallo*). By means of this cliff (*fd* in figure 42. and which is represented separately in fig. 44.), we see the internal structure of the mountain, composed of thick beds (*kk*) of loose scoria, which have fallen in showers; between which thin but firm streams (*mm*) of lava are interposed, which have flowed down the outward conical sides of the mountain. (Fig. 43. is an ideal section of Vesuvius and Somma, through the axis of the cones, shewing the manner in which the beds of scoria and of lava lie upon each other; the extremities of which beds are seen edgewise in the cliff at *mm* and *kk*, fig. 42, 43, and 44.)

THIS assemblage of scoria and lava is traversed abruptly and vertically, by streams of solid lava (*nn*, fig. 44.), reaching from top to bottom of the cliff. These last I conceive to have flowed in rents of the ancient mountain, which rents had acted

as pipes through which the lavas of the lateral eruptions were conveyed to the open air. This scene presents to the view of an attentive observer, a real specimen of those internal streams which we have just been considering in speculation, and they may exhibit circumstances decisive of the opinions here advanced. For, if one of these streams had formerly been connected with a lateral eruption, discharged at more than 600 feet above the *Atrio del Cavallo*, it might possibly contain the carbonate of lime. But could we suppose that depth to extend to 1708 feet, the interference of air-bubbles, and the action of a stronger heat than was merely required for the fusion of the carbonate, might have been overcome.

PERHAPS the height of Vesuvius has never been great enough for this purpose. But could we suppose *Ætna* to be cleft in two, and its structure displayed, as that of Vesuvius has just been described, there can be no doubt that internal streams of lava would be laid open, in which the pressure must have far exceeded the force required to constrain the carbonic acid of limestone; since that mountain occasionally delivers lavas from its summit, placed 10,954 feet above the level of the Mediterranean*, which washes its base. I recollect having seen, in some parts of *Ætna*, vast chasms and crags, formed by volcanic revolutions, in which vertical streams of lava, similar to those of Somma, were apparent. But my attention not having been turned to that object till many years afterwards, I have only now to recommend the investigation of this interesting point to future travellers.

WHAT has been said of the heat conveyed by internal volcanic streams, applies equally to that deeper and more general heat by which the lavas themselves are melted and propelled upwards.

* *Phil. Transf.* 1777, p. 595.

upwards. That they have been really so propelled, from a great internal mass of matter, in liquid fusion, seems to admit of no doubt, to whatever cause we ascribe the heat of volcanoes. It is no less obvious, that the temperature of that liquid must be of far greater intensity than the lavas, flowing from it, can retain when they reach the surface. Independently of any actual eruption, the body of heat contained in this vast mass of liquid, must diffuse itself through the surrounding substances, the intensity of the heat being diminished by slow gradations, in proportion to the distance to which it penetrates. When, by means of this progressive diffusion, the heat has reached an assemblage of loose marine deposits, subject to the pressure of a great superincumbent weight, the whole must be agglutinated into a mass, the solidity of which will vary with the chemical composition of the substance, and with the degree of heat to which each particular spot has thus been exposed. At the same time, analogy leads us to suppose, that this deep and extensive heat must be subject to vicissitudes and intermissions, like the external phenomena of volcanoes. We have endeavoured to explain some of these irregularities, and a similar reasoning may be extended to the present case. Having shewn, that small internal streams of lava tend successively to pervade every weak part of a volcanic mountain, we are led to conceive, that the great masses of heated matter just mentioned, will be successively directed to different parts of the earth; so that every loose assemblage of matter, lying in a submarine and subterranean situation, will, in its turn, be affected by the indurating cause; and the influence of internal volcanic heat will thus be circumscribed within no limits but those of the globe itself.

A SERIES of undoubted facts prove, that all our strata once lay in a situation similar in all respects to that in which the marine deposits just mentioned have been supposed to lie.

THE inhabitant of an unbroken plain, or of a country formed of horizontal strata, whose observations have been confi-

ned to his native spot, can form no idea of those truths, which at every step in an alpine district force themselves on the mind of a geological observer. Unfortunately for the progress of geology, both London and Paris, are placed in countries of little interest; and those scenes by which the principles of this science are brought into view in the most striking manner, are unknown to many persons best capable of appreciating their value. The most important, and at the same time, the most astonishing truth which we learn by any geological observations, is, that rocks and mountains now placed at an elevation of more than two miles above the level of the sea, must at one period have lain at its bottom. This is undoubtedly true of those strata of limestone which contain shells; and the same conclusion must be extended to the circumjacent strata. The imagination struggles against the admission of so violent a position; but must yield to the force of unquestionable evidence; and it is proved by the example of the most eminent and cautious observers, that the conclusion is inevitable*.

ANOTHER question here occurs, which has been well treated by Mr PLAYFAIR. Has the sea retreated from the mountains? or have they risen out of the sea? He has shewn, that the balance of probability is incomparably in favour of the latter supposition; since, in order to maintain the former, we must dispose of an enormous mass of sea, whose depth is several miles, and whose base is greater than the surface of the whole sea. Whereas the elevation of a continent out of a sea like ours, would not change its level above a few feet; and even were a great derangement thus occasioned,

* SAUSSURE, *Voyages dans les Alpes*, tom. ii. p. 99.—104.

sioned, the water would easily find its level without the assistance of any extraordinary supposition. The elevation of the land, too, is evinced by what has occasionally happened in volcanic regions, and affords a complete solution of the contortion and erection of strata, which are almost universally admitted to have once lain in a plane and horizontal position.

WHATEVER opinion be adopted as to the mode in which the land and the water have been separated, no one doubts of the ancient submarine situation of the strata.

AN important series of facts proves, that they were likewise subterranean. Every thing indicates that a great quantity of matter has been removed from what now constitutes the surface of our globe, and enormous deposits of loose fragments, evidently detached from masses similar to our common rock, evince the action of some very powerful agent of destruction. Analogy too, leads us to believe, that all the primary rocks have once been covered with secondary; yet, in vast districts, no secondary rock appears. In short, geologists seem to agree in admitting the general position, that very great changes of this kind have taken place in the solid surface of the globe, however much they may differ as to their amount, and as to their causes.

DR HUTTON ascribed these changes to the action, during very long time, of those agents, which at this day continue slowly to corrode the surface of the earth; frosts, rains, the ordinary floods of rivers, &c. which he conceives to have acted always with the same force, and no more. But to this opinion I could never subscribe, having early adopted that of SAUSSURE, in which he is joined by many of the continental geologists. My conviction was founded upon the inspection of those facts in the neighbourhood of Geneva, which he has adduced in support of his opinion. I was then convinced,

and I still believe, that vast torrents, of depth sufficient to overtop our mountains, have swept along the surface of the earth, excavating vallies, undermining mountains, and carrying away whatever was unable to resist such powerful corrosion. If such agents have been at work in the Alps, it is difficult to conceive that our countries should have been spared. I made it therefore my business to search for traces of similar operations here. I was not long in discovering such in great abundance; and, with the help of several of my friends, I have traced the indications of vast torrents in this neighbourhood, as obvious as those I formerly saw on Saleve and Jura. Since I announced my opinion on this subject, in a note subjoined to my paper on Whinstone and Lava, published in the fifth volume of the *Transactions* of this Society, I have met with many confirmations of these views. The most important of these are derived from the testimony of my friend Lord SELKIRK, who has lately met with a series of similar facts in North America.

It would be difficult to compute the effects of such an agent; but if, by means of it, or of any other cause, the whole mass of secondary strata, in great tracts of country, has been removed from above the primary, the weight of that mass alone must have been sufficient to fulfil all the conditions of the Huttonian Theory, without having recourse to the pressure of the sea. But when the two pressures were combined, how great must have been their united strength!

WE are authorized to suppose, that the materials of our strata, in this situation, underwent the action of fire. For volcanoes have burnt long before the earliest times recorded in history, as appears by the magnitude of some volcanic mountains; and it can scarcely be doubted, that their fire has acted without any material cessation ever since the surface of our globe acquired its present

present form. In extending that same influence to periods of still higher antiquity, when our strata lay at the bottom of the sea, we do no more than ascribe permanence to the existing laws of nature.

THE combination of heat and compression resulting from these circumstances, carries us to the full extent of the Huttonian Theory, and enables us, upon its principles, to account for the igneous formation of all rocks from loose marine deposits.

THE sand would thus be changed to sandstone; the shells to limestone; and the animal and vegetable substances to coal.

OTHER beds, consisting of a mixture of various substances, would be still more affected by the same heat. Such as contained iron, carbonate of lime, and alkali, together with a mixture of various earths, would enter into thin fusion, and, penetrating through every crevice that occurred, would, in some cases, reach what was then the surface of the earth, and constitute lava: in other cases, it would congeal in the internal rents, and constitute porphyry, basalt, greenstone, or any other of that numerous class of substances, which we comprehend under the name of *whinstone*. At the same time, beds of similar quality, but of composition somewhat less fusible, would enter into a state of viscosity, such as many bodies pass through in their progress towards fusion. In this state, the particles, though far from possessing the same freedom as in a liquid, are susceptible of crystalline arrangement*; and the
substance

* THIS state of viscosity, with its numberless modifications, is deserving of great attention, since it affords a solution of some of the most important geological questions. The mechanical power exerted by some substances, in the act of assuming a crystalline form, is well known. I have seen a set of large and broad
crystals

substance, which, in this sluggish state, would be little disposed to move, being confined in its original situation by contiguous beds of more refractory matter, would crystallize, without undergoing any change of place, and constitute one of those beds of whinstone, which frequently occur interstratified with sandstone and limestone.

IN other cases where the heat was more intense, the beds of sand, approaching more nearly to a state of fusion, would acquire such tenacity and toughness, as to allow themselves to be bent and contorted, without laceration or fracture, by the influence of local motions, and might assume the shape and character of primary schistus: the limestone would be highly crystallized, and would become marble, or, entering into thin fusion, would penetrate the minutest rents in the form of calcareous spar. Lastly, when the heat was higher still, the sand itself would be entirely melted, and might be converted, by the subsequent effects of slow cooling, into granite, sienite, &c.; in some cases, retaining traces of its original stratification, and constituting gneiss and stratified granite; in others, flowing into the crevices, and forming veins of perfect granite.

IN consequence of the action of heat, upon so great a quantity of matter, thus brought into a fluid or semifluid state, and in which, notwithstanding the great pressure, some substances would be volatilized, a powerful heaving of the superincumbent mass must have taken place; which, by repeated efforts, succeeding

crystals of ice, like the blade of a knife, formed in a mass of clay, of such stiffness, that it had just been used to make cups for chemical purposes. In many of my former experiments, I found that a fragment of glass made from whinstone or lava, when placed in a muffle heated to the melting point of silver, assumed a crystalline arrangement, and underwent a complete change of character. During this change, it became soft, so as to yield to the touch of an iron rod; yet retained such stiffness, that, lying untouched in the muffle, it preserved its shape entirely; the sharp angles of its fracture not being in the least blunted.

ceeding each other from below, would at last elevate the strata into their present situation.

THE Huttonian Theory embraces so wide a field, and comprehends the laws of so many powerful agents, exerting their influence in circumstances and in combinations hitherto untried, that many of its branches must still remain in an unfinished state, and may long be exposed to partial and plausible objections, after we are satisfied with regard to its fundamental doctrines. In the mean time I trust, that the object of our pursuit has been accomplished, in a satisfactory manner, by the fusion of limestone under pressure. This single result affords, I conceive, a strong presumption in favour of the solution which Dr HUTTON has advanced of all the geological phenomena; for, the truth of the most doubtful principle which he has assumed, has thus been established by direct experiment.

APPEN-

CHAPTER I
THE EARLY HISTORY OF THE UNITED STATES

The first European settlers in North America were the Spanish, who discovered the continent in 1492. They established colonies in the south and west, and the English followed in the north. The French also established colonies in the north and west. The Dutch and Swedish also established colonies in the north.

The English colonies in the north were the first to develop a sense of independence. They fought the American Revolutionary War, which began in 1775 and ended in 1781. The war resulted in the United States becoming an independent nation.

The United States continued to expand westward. The Louisiana Purchase of 1803 doubled the size of the country. The Texas Revolution of 1835-1836 resulted in Texas becoming an independent republic. The Mexican-American War of 1846-1848 resulted in the United States acquiring California, New Mexico, and Arizona.

The United States continued to expand westward. The California Gold Rush of 1849-1852 resulted in a large influx of people to California. The Civil War of 1861-1865 resulted in the United States becoming a unified nation.

The United States continued to expand westward. The Spanish-American War of 1898 resulted in the United States acquiring Puerto Rico, Guam, and the Philippines. The United States continued to expand westward.

APPENDIX.

No. I.

SPECIFIC GRAVITY OF SOME OF THE FOREGOING RESULTS.

AS many of the artificial limestones and marbles produced in these experiments, were possessed of great hardness and compactness, and as they had visibly undergone a great diminution of bulk, and felt heavy in the hand, it seemed to me an object of some consequence to ascertain their specific gravity, compared with each other, and with the original substances from which they were formed. As the original was commonly a mass of chalk in the lump, which, on being plunged into water, begins to absorb it rapidly, and continues to do so during a long time, so as to vary the weight at every instant, it was impossible, till the absorption was complete, to obtain any certain result; and to allow for the weight thus gained, required the application of

a method different from that usually employed in estimating specific gravity.

IN the common method, the substance is first weighed in air, and then in water; the difference indicating the weight of water displaced, and being considered as that of a quantity of water equal in bulk to the solid body. But as chalk, when saturated with water, is heavier, by about one-fourth, than when dry, it is evident, that its apparent weight, in water, must be increased, and the apparent loss of weight diminished exactly to that amount. To have a just estimate, then, of the quantity of water displaced by the solid body, the apparent loss of weight must be increased, by adding the absorption to it.

Two distinct methods of taking specific gravity thus present themselves, which it is of importance to keep separate, as each of them is applicable to a particular class of subjects.

ONE of these methods, consists in comparing a cubic inch of a substance in its dry state, allowing its pores to have their share in constituting its bulk, with a cubic inch of water.

THE other depends upon comparing a cubic inch of the solid matter of which the substance is composed, independently of vacuities, and supposing the whole reduced to perfect solidity, with a cubic inch of water.

THUS, were an architect to compute the efficacy of a given bulk of earth, intended to load an abutment, which earth was dry, and should always remain so, he would undoubtedly follow the first of these modes: Whereas, were a farmer to compare the specific gravity of the same earth with that of any other soil, in an agricultural point of view, he would use the second mode, which is involved in that laid down by Mr DAVY.

As our object is to compare the specific density of these results, and to ascertain to what amount the particles have approached

proached each other, it seems quite evident that the first mode is suited to our purpose. This will appear most distinctly, by inspection of the following Table, which has been constructed so as to include both.

Z 2

TABLE.

TABLE OF SPECIFIC GRAVITIES.

I.	II. Weight in air, dry.	III. Weight in water.	IV. Weight in air, wet.	V. Difference between Columns II. & III.	VI. Difference between Columns II. & IV. or absorption.	VII. Absorp- tion per cent.	VIII. Sum of Columns V. and VI.	IX. Specific gravity by com- mon mode.	X. Specific gravity by new mode.
1.	125.90	77.55	135.65	47.35	9.75	7.74	57.10	2.604	2.204
2.	9.94	6.13	9.99	3.81	0.05	0.50	3.86	2.609	2.575
3.	15.98	9.70	16.02	6.28	0.04	0.25	6.32	2.544	2.528
4.	5.47	3.33	5.48	2.14	0.01	0.18	2.15	2.556	2.544
5.	18.04	10.14	18.06	7.90	0.02	0.11	7.92	2.283	2.277
6.	6.48	3.74	7.10	2.74	0.62	9.56	3.36	2.305	1.928
7.	10.32	5.97	10.36	4.35	0.04	0.39	4.39	2.372	2.350
8.	54.57	31.30	55.23	23.27	0.66	1.21	23.93	2.345	2.280
9.	72.27	41.10	76.13	31.17	3.86	5.34	35.03	2.318	2.063
10.	37.75	21.15	38.30	16.60	0.55	1.45	17.15	2.274	2.201
II.	21.21	12.55	21.26	8.66	0.05	0.24	8.71	2.449	2.435
I2. Marble.	18.59	11.56	18.61	7.03	0.02	0.18	7.05	2.644	2.636
I3. Chalk.	504.15	302.40	623.20	201.75	119.05	23.61	320.80	2.498	1.571
I4. Average Chalk.	444.30	264.35	550.80	179.95	106.50	23.97	286.45	2.469	1.551
I5. rammed Powder.	283.97	—	—	—	—	—	198.65	—	1.429

EXPLANATION.

COLUMN I. contains the number affixed to each of the specimens, whose properties are expressed in the table.

THE

THE first eleven are the same with those used in the paper read in this Society on the 30th of August 1804, and published in NICHOLSON'S *Journal* for October following, and which refer to the same specimens. No. 12. Is a specimen of yellow marble, bearing a strong resemblance to No. 3. No. 13. A specimen of chalk. No. 14. Shews the average of three trials with chalk. No. 15. Some pounded chalk, rammed in the manner followed in these experiments. In order to ascertain its specific gravity, I rammed the powder into a glass-tube, previously weighed; then, after weighing the whole, I removed the chalk, and filled the same tube with water. I thus ascertained, in a direct manner, the weight of the substance, as stated in Column II., and that of an equal bulk of water, stated in Column VIII.

COLUMN II. Weight of the substance, dry in air, after exposure, during several hours to a heat of 212° of FAHRENHEIT.

COLUMN III. Its weight in water, after lying long in the liquid, so as to perform its full absorption; and all air-bubbles being carefully removed.

COLUMN IV. Weight in air, wet. The loose external moisture being removed by the touch of a dry cloth; but no time being allowed for evaporation.

COLUMN V. Difference between Columns II. and III., or apparent weight of water displaced.

COLUMN VI. Difference between Columns II. and IV., or the absorption

COLUMN VII. Absorption reduced to a *per centage* of the dry substance.

COLUMN VIII. Sum of Columns V. and VI., or the real weight of water displaced by the body.

COLUMN IX. Specific gravity, by the common mode, resulting from the division of Column II. by Column V.

COLUMN X. Specific gravity, in the new mode, resulting from the division of Column II. by Column VIII.

THE

THE specific gravities ascertained by the new mode, and expressed in Column X. correspond very well to the idea which is formed of their comparative densities, from other circumstances, their hardness, compact appearance, susceptibility of polish, and weight in the hand.

THE case is widely different, when we attend to the results of the common method contained in Column IX. Here the specific gravity of chalk is rated at 2.498, which exceeds considerably that of a majority of the results tried. Thus, it would appear, by this method, that chalk has become lighter by the experiment, in defiance of our senses, which evince an increase of density.

THIS singular result arises, I conceive, from this, that, in our specimens, the faculty of absorption has been much more decreased than the porosity. Thus, if a piece of crude chalk, whose specific gravity had previously been ascertained by the common mode, and then well dried in a heat of 212° , were dipped in varnish, which would penetrate a little way into its surface; and, the varnish having hardened, the chalk were weighed in water, it is evident, that the apparent loss of weight would now be greater by 23.61 *per cent.* of the dry weight, than it had been when the unvarnished chalk was weighed in water; because the varnish, closing the superficial pores, would quite prevent the absorption, while it added but little to the weight of the mass, and made no change on the bulk. In computing, then, the specific gravity, by means of this last result, the chalk would appear very much lighter than at first, though its density had, in fact, been increased by means of the varnish.

A SIMILAR effect seems to have been produced in some of these results, by the agglutination or partial fusion of part of the substance, by which some of the pores have been shut out from the water.

THIS

THIS view derives some confirmation from an inspection of Columns VI. and VII.; the first of which expresses the absorption; and the second, that result, reduced to a *per centage* of the original weight. It there appears, that whereas chalk absorbs 23.97 *per cent.*, some of our results absorb only 0.5, or so low as 0.11 *per cent.* So that the power of absorption has been reduced from about one-fourth, to less than the five hundredth of the weight.

I HAVE measured the diminution of bulk in many cases, particularly in that of No. 11. The chalk, when crude, ran to the 75th degree of WEDGWOOD's gage, and shrank so much during the experiment, that it ran to the 161st; the difference amounting to 86 degrees. Now, I find, that WEDGWOOD's gage tapers in breadth, from 0.5 at zero of the scale, to 0.3 at the 240th degree. Hence, we have for one degree 0.000833. Consequently, the width, at the 75th degree, amounts to 0.437525; and at the 161st, to 0.365887. These numbers, denoting the linear measure of the crude chalk, and of its result under heat and compression, are as 100 to 83.8; or, in solid bulk, as 100 to 57.5. Computing the densities from this source, they are as 1 to 1.73. The specific gravities in the Table, of the chalk, and of this result, are as 1.551 : 2.435; that is, as 1 to 1.57. These conclusions do not correspond very exactly; but the chalk employed in this experiment, was not one of those employed in determining average specific gravity in the Table; and other circumstances may have contributed to produce irregularity. Comparing this chalk with result second, we have 1.551 : 2.575 so 1 : 1.6602.

TABLE

No. II.

TABLE,

CONTAINING THE REDUCTION OF THE FORCES MENTIONED
IN CHAP. VII. TO A COMMON STANDARD.

I. Number of experiment referred to in Chap. VII.	II. Bore, in de- cimals of an inch.	III. Pressure in hundred weights.	IV. Tempera- ture by WEDG- WOOD'S pyrometer.	V. Depth of sea in feet.	VI Ditto in miles.	VII. Pressure, ex- pressed in at- mospheres
1	0.75	3	22	1708.05	0.3235	51.87
2	0.75	3	25	1708.05	0.3235	51.87
3	0.75	10	20	5693.52	1.0783	172.92
4	0.75	10	31	5693.52	1.0783	172.92
5	0.75	10	41	5693.52	1.0783	172.92
6	0.75	10	51	5693.52	1.0783	172.92
7	0.75	10	—	5693.52	1.0783	172.92
8	0.54	2	—	2196.57	0.4160	66.71
9	0.54	4	—	4393.14	0.8320	133.43
		8.1	—	8896.12	1.6848	270.19
10	0.75	3	21	1708.05	0.3235	51.87
11	0.75	4	25	2277.41	0.4313	69.70
12	0.75	5	—	2846.76	0.5390	86.46

EXPLANATION.

EXPLANATION.

COLUMN I. contains the number of the experiment, as referred to in the text. Column II. The bore of the barrel used, in decimals of an inch. Column III. The absolute force applied to the barrel, in hundred-weights. Column IV. The temperature, in WEDGWOOD'S scale. Column V. The depth of sea at which a force of compression would be exerted equal to that sustained by the carbonate in each experiment, expressed in feet. Column VI. The same in miles. Column VII. Compressing force, expressed in atmospheres.

BOTH Tables were computed separately, by a friend, Mr J. JARDINE, and myself.

THE following data were employed.

AREA of a circle of which the diameter is unity, 0.785398.

WEIGHT of a cubic foot of distilled water, according to Professor ROBISON, 998.74 ounces avoirdupois.

MEAN specific gravity of sea-water, according to BLADH, 1.0272.

MEAN height of the barometer at the level of the sea 29.91196 English inches, according to LAPLACE.

SPECIFIC gravity of mercury, according to CAVENDISH and BRISSON, 13.568.

EXPLANATION.

Column I. contains the number of the experiment as referred to in the text. Column II. The bore of the barrel in decimals of an inch. Column III. The elastic force applied to the barrel, in hundred-weights. Column IV. The temperature in Woodcock's scale. Column V. The depth of the atmosphere a force of compression would be equal to that obtained by the barometer in each experiment, expressed in feet. Column VI. The time in miles. Column VII. Compressing force, expressed in atmospheres.

From Tables were computed separately for a fixed Air Pressure, and weight.

The following data were employed.

Area of a circle, in which the diameter is unity, 0.7854.

Weight of a cubic foot of distilled water, 62.425 lbs.

Mean specific gravity of the water, 1.000.

Mean height of the barometer, at the level of the sea, 30.000 inches, according to Barometer.

Barometric pressure of mercury, reduced to 30.000 inches, 30.000.

Barometer, 13.508.

Fig. 1.



Fig. 2.



Fig. 3.

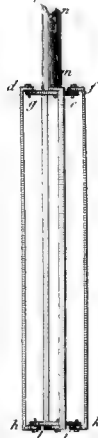

Fig. 4.

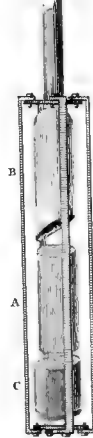

Fig. 5.

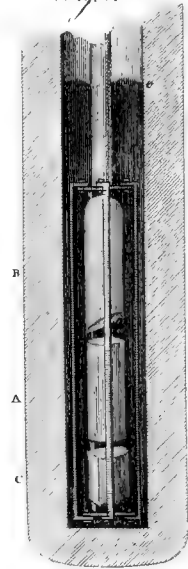

Fig. 6.



Fig. 7.

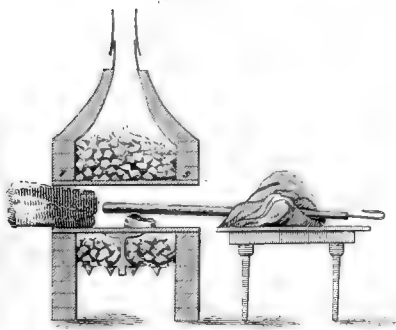

Fig. 8.

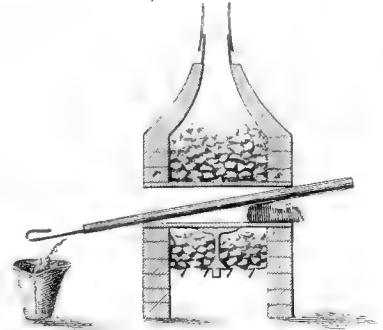



Fig. 9.



Fig. 10.

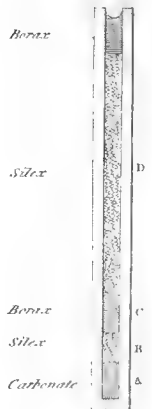

Fig. 11.



Fig. 12.

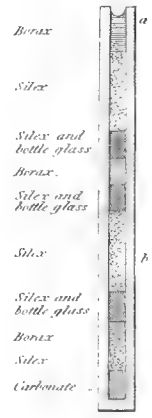

Fig. 13.

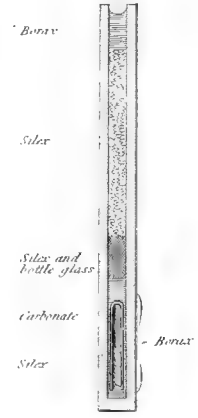

Fig. 14.

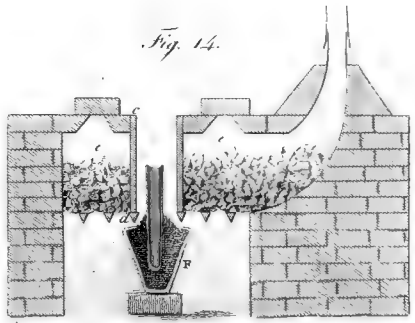

Fig. 15.

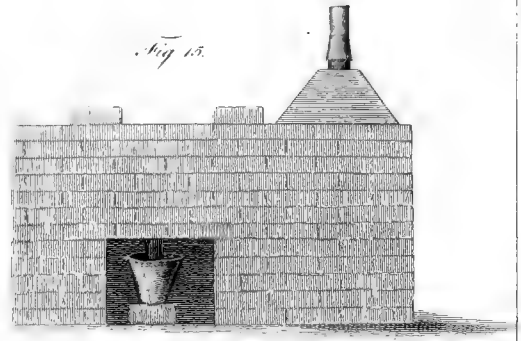

Fig. 16.

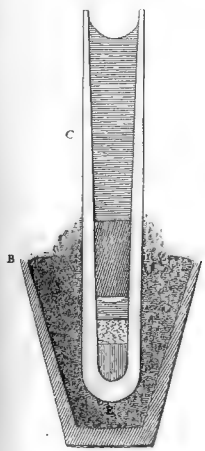

Fig. 17.

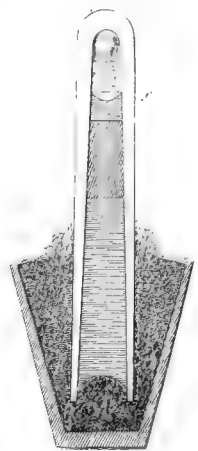

Fig. 18.

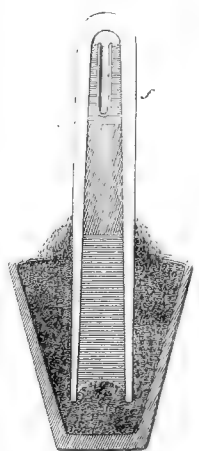
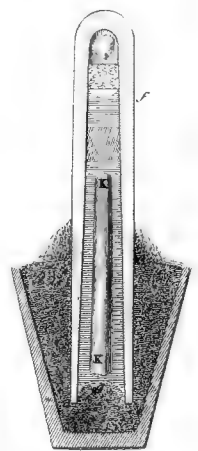

Fig. 19.





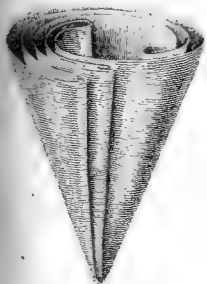
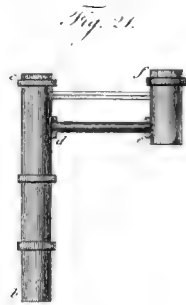
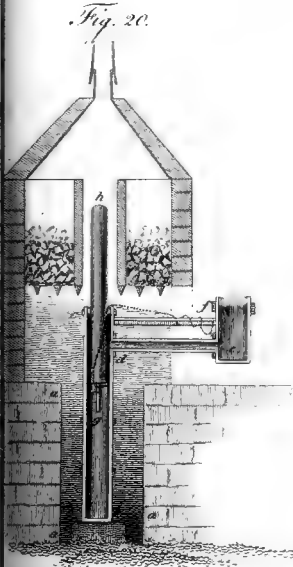
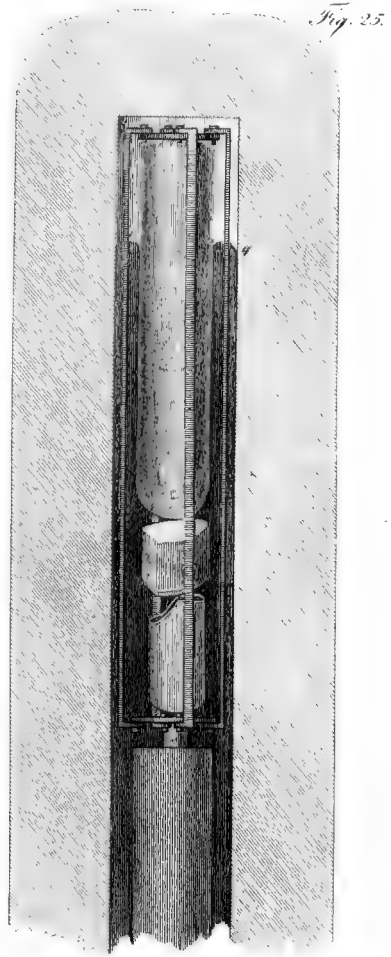
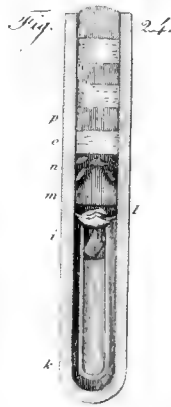



Fig. 35.

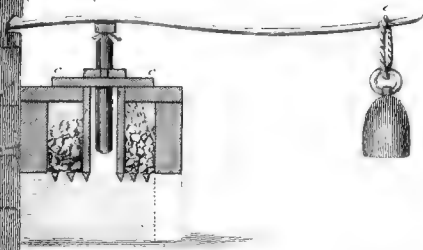

Fig. 36.

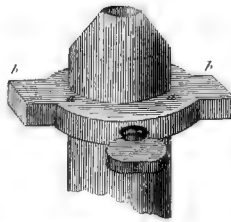

Fig. 37.

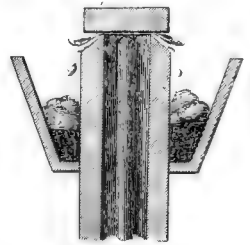

Fig. 38.

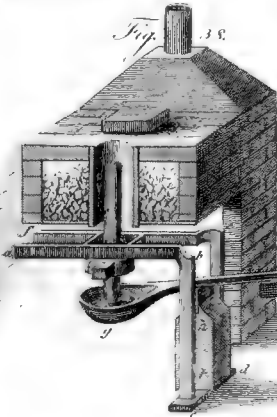

Fig. 39.

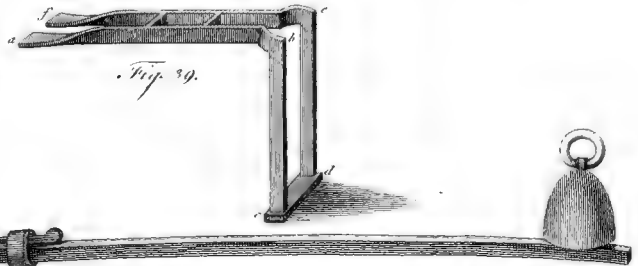
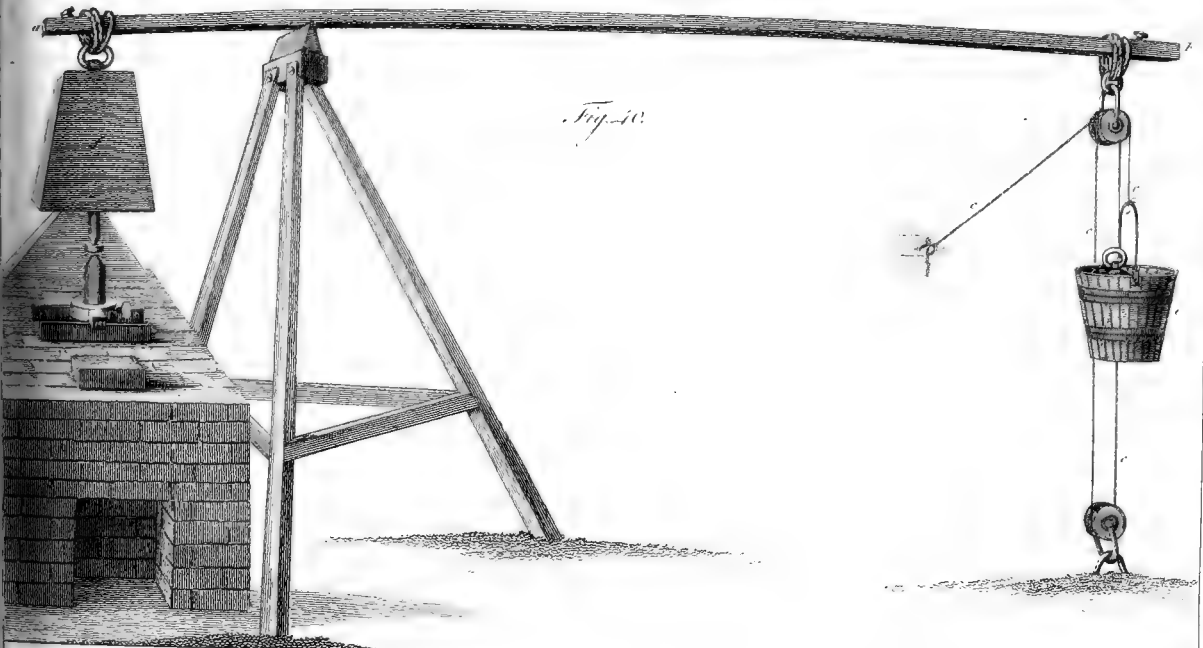

Fig. 40.



J. H. del.

W. J. sculp.



Fig. 41.



Fig. 42.



Fig. 43.

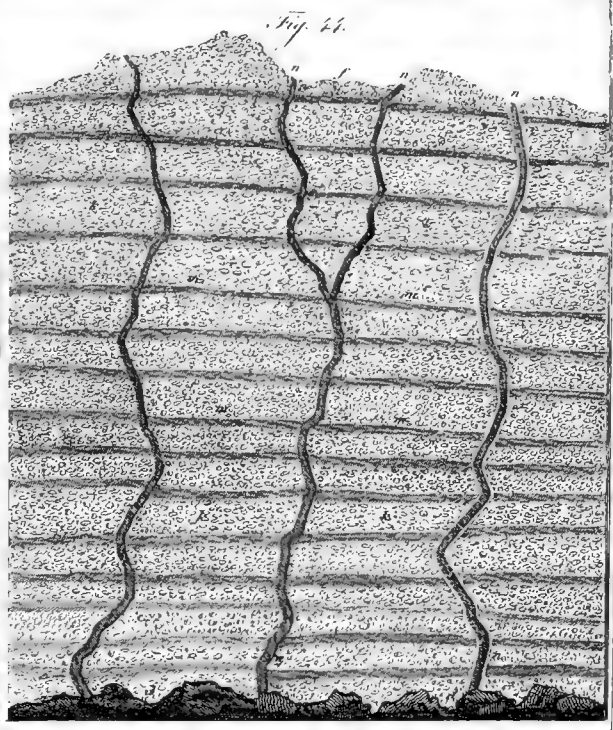
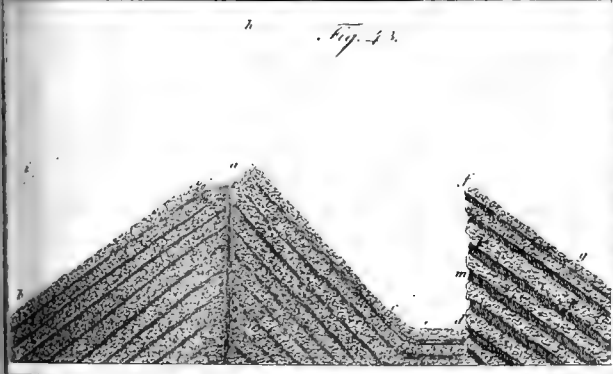

Fig. 44.





IV. *Of the SOLIDS of GREATEST ATTRACTION; or those which, among all the SOLIDS that have certain Properties, Attract with the greatest Force in a given Direction. By JOHN PLAYFAIR, F. R. S. Lond. and Edin. and Professor of Natural Philosophy in the University of Edinburgh.*

[Read 5th January 1807.]

THE investigations which I have at present the honour of submitting to the Royal Society, were suggested by the experiments which have been made of late years concerning the gravitation of terrestrial bodies, first, by Dr MASKELYNE, on the Attraction of Mountains, and afterwards by Mr CAVENDISH, on the Attraction of Leadén Balls.

IN reflecting on these experiments, a question naturally enough occurred, what figure ought a given mass of matter to have, in order that it may attract a particle in a given direction, with the greatest force possible? This seemed an inquiry not of mere curiosity, but one that might be of use in the further prosecution of such experiments as are now referred to. On considering the question more nearly, I soon found, though it belongs to a class of problems of considerable difficulty, which the CALCULUS VARIATIONUM is usually employed to resolve, that it nevertheless admits of an easy solution, and one leading to results of remarkable simplicity, such as may interest

Mathematicians by that circumstance, as well as by their connection with experimental inquiries.

IN the problem thus proposed, no condition was joined to that of the greatest attraction, but that of the quantity of homogeneous matter being given. This is the most general state of the problem. It is evident, however, that other conditions may be combined with the two preceding; it may be required that the body shall have a certain figure, conical, for example, cylindrical, &c. and the problem, under such restrictions, may be still more readily applicable to experiments than in its most general form.

THOUGH the question, thus limited, belongs to the common method of MAXIMA and MINIMA, it leads to investigations that are in reality considerably more difficult than when it is proposed in its utmost generality.

AMONG the following investigations, there are also some that have a particular reference to the experiments on SCHEHALLIEN. A few years ago, an attempt was made by Lord WEBB SEYMOUR and myself, toward such a survey of the rocks which compose that mountain, as might afford a tolerable estimate of their specific gravity, and thereby serve to correct the conclusions, deduced from Dr MASKELYNE'S observations, concerning the mean density of the earth. The account of this survey, and of the conclusions arising from it, belongs naturally to the Society under whose direction the original experiment was made; what is offered here, is an investigation of some of the theorems employed in obtaining those conclusions. When a new element, the heterogeneity of the mass, or the unequal distribution of density in the mountain, was to be introduced into the calculations, the ingenious methods employed by Dr HUTTON could not always be pursued. The propositions that relate to the attraction of a half, or quarter cylinder, on a particle placed in its axis, are intended to remedy this inconvenience,

ence, and will probably be found of use in all inquiries concerning the disturbance of the direction of the plumb-line by inequalities, whether in the figure or density of the exterior crust of the globe.

THE first of the problems here resolved, has been treated of by BOSCOVICH; and his solution is mentioned in the catalogue of his works, as published in the memoirs of a philosophical society at Pisa. I have never, however, been able to procure a sight of these memoirs, nor to obtain any account of the solution just mentioned, and therefore am sensible of hazarding a good deal, when I treat of a subject that has passed through the hands of so able a mathematician, without knowing the conclusions which he has come to, or the principles which he has employed in his investigation. In such circumstances, if my result is just, I cannot reasonably expect it to be new; and I should, indeed, be much alarmed to be told, that it has not been anticipated. The other problems contained in this paper, as far as I know, have never been considered.

I.

To find the solid into which a mass of homogeneous matter must be formed, in order to attract a particle given in position, with the greatest force possible, in a given direction.

LET A (Fig. 1. Pl. 6.) be the particle given in position, AB the direction in which it is to be attracted; and ACBH a section of the solid required, by a plane passing through AB.

SINCE the attraction of the solid is a maximum, by hypothesis, any small variation in the figure of the solid, provided the quantity of matter remain the same, will not change the attraction in the direction AB. If, therefore, a small portion of matter be taken from any point C, in the superficies of the solid, and placed at D, another point in the same superficies, there

will be no variation produced in the force which the solid exerts on the particle A, in the direction AB.

THE curve ACB, therefore, is the locus of all the points in which a body being placed, will attract the particle A in the direction AB, with the same force.

THIS condition is sufficient to determine the nature of the curve ABC. From C, any point in that curve, draw CE perpendicular to AB; then if a mass of matter placed at C be called m^3 , $\frac{m^3}{AC^2}$ will be the attraction of that mass on A, in the direction AC, and $\frac{m^3 \times AE}{AC^3}$ will be its attraction in the direction AB. As this is constant, it will be equal to $\frac{m^3}{AB^2}$, and therefore $AB^2 \times AE = AC^3$.

ALL the sections of the required solid, therefore, by planes passing through AB, have this property, that $AC^3 = AB^2 \times AE$; and as this equation is sufficient to determine the nature of the curve to which it belongs, therefore all the sections of the solid, by planes that pass through AB, are similar and equal curves; and the solid of consequence may be conceived to be generated by the revolution of ACB, any one of these curves, about AB as an axis.

THE solid so generated may be called the *Solid of greatest Attraction*; and the line ACB, the *Curve of equal Attraction*.

II.

To find the equation between the co-ordinates of ACB, the curve of equal attraction.

FROM

FROM C (Fig. 1.) draw CE perpendicular to AB; let $AB=a$, $AE=x$, $EC=y$. We have found $AB^2 \times AE = AC^3$, that is, $a^2 x = (x^2 + y^2)^{\frac{3}{2}}$, or $a^4 x^2 = (x^2 + y^2)^3$, which is an equation to a line of the 6th order.

To have y in terms of x , $x^2 + y^2 = a^{\frac{4}{3}} x^{\frac{2}{3}}$, $y^2 = a^{\frac{4}{3}} x^{\frac{2}{3}} - x^2$,
and $y = x^{\frac{1}{3}} \sqrt{a^{\frac{4}{3}} - x^{\frac{4}{3}}}$.

HENCE $y = 0$, both when $x = 0$, and when $x = a$. Also if x be supposed greater than a , y is impossible. No part of the curve, therefore, lies beyond B.

THE parts of the curve on opposite sides of the line AB, are similar and equal, because the positive and negative values of y are equal. There is also another part of the curve on the side of A, opposite to B, similar and equal to ACB; for the values of y are the same whether x be positive or negative.

III.

THE curve may easily be constructed without having recourse to the value of y just obtained.

LET $AB = a$, (Fig. 1.) $AC = z$, and the angle $BAC = \phi$. Then $AE = AC \times \cos \phi = z \cos \phi$, and so $a^2 z \cos \phi = z^3$, or $a^2 \cos \phi = z^2$; hence $z = a \sqrt{\cos \phi}$.

FROM this formula a value of AC or z may be found, if ϕ or the angle BAC be given; and if it be required to find z in numbers, it may be conveniently calculated from this expression. A geometrical construction may also be easily derived from it. For if with the radius AB, a circle BFH be described from the centre A; if AC be produced to meet the circumference

ence in F, and if FG be drawn at right angles to AB, then

$$\frac{AG}{AB} = \cos \phi, \text{ and so } z = a \times \sqrt{\frac{AG}{AB}} = \sqrt{AB \times AG} = AC.$$

THEREFORE, if from the centre A, with the distance AB, a circle BFH be described, and if a circle be also described on the diameter AB, as AKB, then drawing any line AF from A, meeting the circle BFH in F, and from F letting fall FG perpendicular on AB, intersecting the semicircle AKB in K; if AK be joined, and AC made equal to AK, the point C is in the curve.

FOR $AK = \sqrt{AB \times AG}$, from the nature of the semicircle, and therefore $AC = \sqrt{AB \times AG}$, which has been shewn to be a property of the curve. In this way, any number of points of the curve may be determined; and the *Solid of greatest attraction* will be described, as already explained, by the revolution of this curve about the axis AB.

IV.

To find the area of the curve ACB.

I. LET ACE, AFG (Fig. 2.) be two radii, indefinitely near to one another, meeting the curve ACB in C and F, and the circle, described with the radius AB, in E and G. Let $AC = z$ as before, the angle $BAC = \phi$, and $AB = a$. Then $GE = a \dot{\phi}$, and the area $AGE = \frac{1}{2} a^2 \dot{\phi}$, and since $AE^2 : AC^2 :: \text{Sect. AEG} : \text{Sect. ACF}$, the sector $ACF = \frac{1}{2} z^2 \dot{\phi}$. But $z^2 = a^2 \cos \phi$, (§ III.), whence the sector ACF, or the fluxion of the area ABC $= \frac{1}{2} a^2 \dot{\phi} \cos \phi$, and consequently the area ABC $= \frac{1}{2} a^2 \sin \phi$, to which no constant quantity need be added, because it vanishes when $\phi = 0$, or when the area ABC vanishes.

THE

THE whole area of the curve, therefore, is $\frac{1}{2}a^2$, or $\frac{1}{2}AB^2$; for when ϕ is a right angle $\sin \phi = 1$. Hence the area of the curve on both sides of AB is equal to the square of AB.

2. THE value of x , when y is a maximum, is easily found. For when y , and therefore y^2 is a maximum, $\frac{2}{3}a^{\frac{4}{3}}x^{-\frac{1}{3}} = 2x$, or $3x^{\frac{4}{3}} = a^{\frac{4}{3}}$, that is $x = \frac{a}{3} = \frac{a}{\sqrt[3]{27}}$.

HENCE, calling b the value of y when a maximum,

$$b^2 = a^{\frac{4}{3}} \times \frac{a^{\frac{2}{3}}}{27^{\frac{1}{3}}} = \frac{a^2}{27^{\frac{1}{3}}} = a^2 \left(\frac{27^{\frac{1}{3}} - 1}{27^{\frac{1}{3}}} \right) = \frac{2a^2}{\sqrt{27}}, \text{ and so } b = a \frac{\sqrt{2}}{\sqrt[4]{27}}$$

and therefore $a : b :: \sqrt[4]{27} : \sqrt{2}$, or as 11 : 7 nearly.

3. IT is material to observe, that the radius of curvature at A

is infinite. For since $y^2 = a^{\frac{4}{3}}x^{\frac{2}{3}} - x^2$, $\frac{y^2}{x} = \frac{a^{\frac{4}{3}}}{x^{\frac{1}{3}}} - x$. But when

x is very small, or y indefinitely near to A, $\frac{y^2}{x}$ becomes the diameter of the circle having the same curvature with ACB at A,

and when x vanishes, this value of $\frac{y^2}{x}$, or $\frac{a^{\frac{4}{3}}}{x^{\frac{1}{3}}} - x$, becomes infi-

nite, because of the divisor $x^{\frac{1}{3}}$ being in that case $= 0$. The diameter, therefore, and the radius of curvature at A are infinite. In other words, no circle, having its centre in AB produced, and passing through A, can be described with so great a radius, but that, at the point A, it will be within the curve of equal attraction.

THE solid of greatest attraction, then, at the extremity of its axis, where the attracted particle is placed, is exceedingly flat, approaching more nearly to a plane than the superficies of any sphere can do, however great its radius.

4. To find the radius of curvature at B, the other extremity of the axis, since $y^2 = a^{\frac{4}{3}} x^{\frac{2}{3}} - x^2$, if we divide by $a - x$, we have

$$\frac{y^2}{a-x} = \frac{a^{\frac{4}{3}} x^{\frac{2}{3}} - x^2}{a-x}. \text{ But at B, when } a-x, \text{ or the abscissa}$$

reckoned from B vanishes, $\frac{y^2}{a-x}$ is the diameter of the circle

having the same curvature with ACB in B. But when $a-x=0$, or $a=x$, both the numerator and denominator of

the fraction $\frac{a^{\frac{4}{3}} x^{\frac{2}{3}} - x^2}{a-x}$ vanish, so that its ultimate value does

not appear. To remove this difficulty, let $a-x=z$, or

$x=a-z$, then we have $y^2 = a^{\frac{4}{3}} (a-z)^{\frac{2}{3}} - (a-z)^2$. But

when z is extremely small, its powers, higher than the first,

may be rejected; and therefore $(a-z)^{\frac{2}{3}} = a^{\frac{2}{3}} \left(1 - \frac{z}{a}\right)^{\frac{2}{3}} =$

$a^{\frac{2}{3}} \left(1 - \frac{2z}{3a}, \&c.\right)$ Therefore the equation to the curve becomes

in this case, $y^2 = a^{\frac{4}{3}} \times a^{\frac{2}{3}} \left(1 - \frac{2z}{3a}\right) - a^2 + 2az = a^2 - \frac{2}{3}az -$

$$a^2 + 2az = \frac{4}{3}az.$$

HENCE

HENCE $\frac{y^2}{2x}$, or the radius of curvature at B $= \frac{2}{3}a$. The curve, therefore, at B falls wholly without the circle BKA, described on the diameter AB, as its radius of curvature is greater. This is also evident from the construction.

V.

To find the force with which the solid above defined attracts the particle A in the direction AB.

LET b (Fig. 2.) be a point indefinitely near to B, and let the curve Acb be described similar to ACB. Through C draw CcD perpendicular to AB, and suppose the figure thus constructed to revolve about AB; then each of the curves ACB, Acb will generate a solid of greatest attraction; and the excess of the one of these solids above the other, will be an indefinitely thin shell, the attraction of which is the variation of the attraction of the solid ACB, when it changes into Acb .

AGAIN, by the line DC, when it revolves along with the rest of the figure about AB, a circle will be described; and by the part Cc , a circular ring, on which, if we suppose a solid of indefinitely small altitude to be constituted, it will make the element of the solid shell ACc . Now the attraction exerted by this circular ring upon A, will be the same as if all the matter of it were united in the point C, and the same, therefore, as if it were all united in B.

BUT the circular ring generated by Cc , is $= \pi (DC^2 - Dc^2)$
 $= 2\pi DC \times Cc$. Now $2 DC \times Cc$ is the variation of y^2 , or DC^2 , while DC passes into Dc , and the curve BCA into the curve bca ; that is $2 DC \times Cc$ is the fluxion of y^2 , or of $a^{\frac{4}{3}}x^{\frac{2}{3}} - x^2$,

taken on the supposition that x is constant and a variable, viz. $\frac{4}{3} a^{\frac{1}{3}} \dot{a} \times x^{\frac{2}{3}}$. Therefore the space generated by $Cc = \frac{4}{3} \pi a^{\frac{1}{3}} x^{\frac{2}{3}} \dot{a}$.

If this expression be multiplied by \dot{x} , we have the element of the shell $= \frac{4}{3} \pi a^{\frac{1}{3}} x^{\frac{2}{3}} \dot{a} \dot{x}$.

In order to have the solidity of the shell $ACBbc$, the above expression must be integrated relatively to x , that is, supposing only x variable, and it is then $\frac{3}{5} \times \frac{4}{3} \pi a^{\frac{1}{3}} x^{\frac{5}{3}} \dot{a} + C$. But $C=0$, because the fluent vanishes when x vanishes, therefore the portion of the shell $ACc = \frac{4}{5} x^{\frac{5}{3}} a^{\frac{1}{3}} \dot{a}$, and when $x=a$, the whole shell $= \frac{4}{5} \pi a^2 \dot{a}$.

Now, if the whole quantity of matter in the shell were united at B , its attractive force exerted on A , would be the same with that of the shell; therefore the whole force of the shell $= \frac{4}{5} \pi \dot{a}$. The same is true for every other indefinitely thin shell into which the solid may be supposed to be divided; and therefore the whole attraction of the solid is equal to $\int \frac{4}{5} \pi \dot{a}$, supposing a variable, that is $= \frac{4}{5} \pi a$.

HENCE

HENCE we may compare the attraction of this solid with that of a sphere of which the axis is AB, for the attraction of that sphere = $\frac{\pi}{6} a^3 \times \frac{4}{a^2} = \frac{2\pi}{3} a$. The attraction of the solid ADBH, (Fig. 1.) is, therefore, to that of the sphere on the same axis as $\frac{4\pi}{5} a$ to $\frac{2\pi}{3} a$, or as 6 to 5.

VI.

To find the content of the solid ADBH, we need only integrate the fluxionary expression for the content of the shell, viz. $\frac{4\pi}{5} a^2 da$. We have then $\frac{4\pi}{15} a^3 =$ the content of the solid ADBH. Since the solidity of the sphere on the axis a is = $\frac{\pi}{6} a^3$, the content of the solid ADBH is to that of the sphere on the same axis as $\frac{4\pi}{15} a^3$ to $\frac{\pi}{6} a^3$; that is, as $\frac{4}{15}$ to $\frac{1}{6}$, or as 8 to 5.

VII.

LASTLY, To compare the attraction of this solid with the attraction of a sphere of equal bulk, let $m^3 =$ any given mass of matter formed into the solid ADBH; then for determining AB, we have this equation, $\frac{4\pi}{15} a^3 = m^3$, and $a = m \sqrt[3]{\frac{15}{4\pi}}$; and there-

fore also the attraction of the solid, (which is $\frac{4\pi}{5} a^3 = \frac{4\pi}{5} m^3 \sqrt{\frac{15}{4\pi}}$)

$$= m \left(\frac{4 \cdot 5^{\frac{1}{3}} \cdot 3^{\frac{1}{3}} \cdot \pi^{\frac{2}{3}}}{5 \cdot 4^{\frac{1}{3}}} \right) = m \left(\frac{4^{\frac{2}{3}} \cdot 3^{\frac{1}{3}} \cdot \pi^{\frac{2}{3}}}{5^{\frac{2}{3}}} \right) = m \sqrt[3]{\frac{48 \pi^2}{25}}.$$

AGAIN, if m^3 be formed into a sphere, the radius of that sphere $= m \sqrt[3]{\frac{3}{4\pi}}$, and the attraction of it on a particle at its

$$\text{surface} = \frac{m^3}{m^2 \left(\frac{3}{4\pi} \right)^{\frac{2}{3}}} = m \frac{(16 \pi^2)^{\frac{1}{3}}}{9^{\frac{1}{3}}}.$$

HENCE the attraction of the solid ADBH, is to that of a sphere equal to it, as $m \left(\frac{48 \pi^2}{25} \right)^{\frac{1}{3}}$ to $m \left(\frac{16 \pi^2}{9} \right)^{\frac{1}{3}}$; that is, as $(27)^{\frac{1}{3}}$ to $(25)^{\frac{1}{3}}$, or as 3 to the cube-root of 25.

THE ratio of 3 to $\sqrt[3]{25}$, is nearly that of 3 to $3 - \frac{2}{27}$, or of 81 to 79; and this is therefore also nearly equal to the ratio of the attraction of the solid ADBH to that of a sphere of equal magnitude.

VIII.

IT has been supposed in the preceding investigation, that the particle on which the solid of greatest attraction exerts its force is in contact with that solid. Let it now be supposed, that the distance between the solid and the particle is given; the solid being

being on one side of a plane, and the particle at a given distance from the same plane on the opposite side. The mass of matter which is to compose the solid being given, it is required to construct the solid.

LET the particle to be attracted be at A (Fig. 3.), from A draw AA' perpendicular to the given plane, and let EF be any straight line in that plane, drawn through the point A'; it is evident that the axis of the solid required must be in AA' produced. Let B be the vertex of the solid, then it will be demonstrated as has been done above, that this solid is generated by the revolution of the curve of *equal attraction*, (that of which the equation is $y^2 = a^{\frac{4}{3}} x^{\frac{2}{3}} - x^2$), about the axis of which one extremity is at A, and of which the length must be found from the quantity of matter in the solid.

THE solid required, then, is a segment of the solid of greatest attraction, having B for its vertex, and a circle, of which A'E or A'F is the radius, for its base.

To find the solid content of such a segment, CD being = y , and AC = x , we have $y^2 = a^{\frac{4}{3}} x^{\frac{2}{3}} - x^2$, and $\pi y^2 \dot{x} = \pi a^{\frac{4}{3}} x^{\frac{2}{3}} \dot{x} - \pi x^2 \dot{x}$ = the cylinder which is the element of the solid segment.

THEREFORE $\int \pi y^2 \dot{x}$, or the solid segment intercepted between B and D must be $\frac{3}{5} \pi a^{\frac{4}{3}} x^{\frac{5}{3}} - \frac{1}{3} \pi x^3 + C$. This must vanish when $x = a$, or when C comes to B, and therefore C =

$$- \frac{4\pi}{15} a^3.$$

— $\frac{4\pi}{15} a^3$. The segment, therefore, intercepted between B and

C, the line AC being x , is $\frac{4\pi}{15} a^3 - \frac{3\pi}{5} a^{\frac{4}{3}} x^{\frac{5}{3}} + \frac{\pi}{3} x^3$.

THIS also gives $\frac{4\pi}{15} a^3$, for the content of the whole solid, when $x = 0$, the same value that was found by another method at § VI.

Now, if we suppose x to be $= AA'$, and to be given $= b$, the solid content of the segment becomes $\frac{4\pi}{15} a^3 - \frac{3\pi}{5} a^{\frac{4}{3}} b^{\frac{5}{3}} + \frac{\pi}{3} b^3$, which must be made equal to the given solidity which we shall suppose $= m^3$, and from this equation a , which is yet unknown, is to be determined. If,

$$\begin{aligned} \text{then, for } a^{\frac{4}{3}} \text{ we put } u, \text{ we have } \pi \left(\frac{4}{15} u^9 - \frac{3}{5} b^{\frac{5}{3}} u^4 + \frac{1}{3} b^3 \right) \\ = m^3, \text{ or } \frac{4}{15} u^9 - \frac{3}{5} b^{\frac{5}{3}} u^4 = \frac{m^3}{\pi} - \frac{1}{3} b^3 \text{ and } u^9 - \frac{9}{4} b^{\frac{5}{3}} u \\ = \frac{15 m^3}{4\pi} - \frac{15}{12} b^3. \end{aligned}$$

THE simplest way of resolving this equation, would be by the rule of false position. In some particular cases, it may be resolved more easily; thus, if $\frac{15 m^3}{\pi} - \frac{15}{12} b^3 = 0$,

$$u^9 - \frac{9}{4} b^{\frac{5}{3}} u^4 = 0, \text{ and } u^5 = \frac{9}{4} b^{\frac{5}{3}}, \text{ that is } a^{\frac{5}{3}} = \frac{9}{4} b^{\frac{5}{3}} \text{ or } a =$$

$$b \times \left(\frac{9}{4} \right)^{\frac{3}{5}} = b \sqrt[5]{\frac{729}{64}}.$$

IX.

1. IF it be required to find the equation to the superficies of the solid of greatest attraction, and also to the sections of it parallel to any plane passing through the axis; this can readily be done by help of what has been demonstrated above.

LET AHB (Fig. 4.) be a section of the solid, by a plane through AB its axis. Let G be any point in the superficies of the solid, GF a perpendicular from G on the plane AHB, and FE a perpendicular from F on the axis. Let AE = x , EF = z , FG = v , then x , z , and v are the three co-ordinates by which the superficies is to be defined. Let AB = a , EH = y , then, from the nature of the curve AHB, $y^2 = a^{\frac{4}{3}} x^{\frac{2}{3}} - x^2$. But because the plane GEH is at right angles to AB, G and H are in the circumference of a circle of which E is the centre; so that GE = EH = y . Therefore $EF^2 + FG^2 = EH^2$, that is, $z^2 + v^2 = y^2$, and by substitution for y^2 in the former equation, $z^2 + v^2 = a^{\frac{4}{3}} x^{\frac{2}{3}} - x^2$, or $(x^2 + z^2 + v^2)^3 = a^4 x^2$, which is the equation to the superficies of the solid of greatest attraction.

2. IF we suppose EF, that is z , to be given = b , and the solid to be cut by a plane through FG and CD, (CD being parallel to AB), making on the surface of the solid the section DGC; and if AK be drawn at right angles to AB, meeting DC in K, then we have, by writing b for z in either the preceding equations, $b^2 + v^2 = a^{\frac{4}{3}} x^{\frac{2}{3}} - x^2$, and $v^2 = a^{\frac{4}{3}} x^{\frac{2}{3}} - x^2 - b^2$ for the equation of the curve DGC, the co-ordinates being GF and FK, because FK is equal to AE or x .

THIS

THIS equation also belongs to a curve of equal attraction; the plane in which that curve is being parallel to AB, the line in which the attraction is estimated, and distant from it by the space b .

INSTEAD of reckoning the abscissa from K, it may be made to begin at C. If AL or CK = b , then the value of b is determined from the equation $b^2 = a^{\frac{4}{3}} b^{\frac{2}{3}} - b^2$, and if $x = b + u$, u being put for CF, $v^2 = a^{\frac{4}{3}} (b + u)^{\frac{2}{3}} - (b + u)^2 - a^{\frac{4}{3}} b^{\frac{2}{3}} + b^2$, or $v^2 + (b + u)^2 + b^2 = a^{\frac{4}{3}} (b + u)^{\frac{2}{3}}$, or $(v^2 + (b + u)^2 + b^2)^3 = a^4 (b + u)^2$.

WHEN b is equal to the maximum value of the ordinate EH, (IV. 2.) the curve CGD goes away into a point; and if b be supposed greater than this, the equation to the curve is impossible.

X.

THE solid of greatest attraction may be found, and its properties investigated, in the way that has now been exemplified, whatever be the law of the attracting force. It will be sufficient, in any case, to find the equation of the generating curve, or the curve of equal attraction.

THUS, if the attraction which the particle C (Fig. 1.) exerts on the given particle at A, be inversely as the m power of the distance, or as $\frac{1}{AC^m}$, then the attraction in the direction AE

will be $\frac{AE}{AC^{m+1}}$, and if we make this = $\frac{1}{AB^m}$, we have $\frac{AE}{AC^{m+1}} = \frac{1}{AB^m}$

$= \frac{1}{AB^m}$, or making $AE = x$, $EC = y$, and $AB = a$, as before,

$$\frac{x}{(x^2 + y^2)^{\frac{m+1}{2}}} = \frac{1}{a^m}, \text{ or } a^m x = (x^2 + y^2)^{\frac{m+1}{2}}, \text{ and } x^2 + y^2 =$$

$$a^{\frac{2m}{m+1}} x^{\frac{2}{m+1}}, \text{ or } y^2 = a^{\frac{2m}{m+1}} x^{\frac{2}{m+1}} - x^2.$$

If $m = 1$, or $m + 1 = 2$, this equation becomes $y^2 = a x - x^2$, being that of a circle of which the diameter is AB . If, therefore, the attracting force were inverſely as the diſtance, the ſolid of greateſt attraction would be a ſphere.

If the force be inverſely as the cube of the diſtance, or $m = 3$, and $m + 1 = 4$, the equation is $y^2 = a^{\frac{3}{2}} x^{\frac{1}{2}} - x^2$, which belongs to a line of the 4th order.

If $m = 4$, and $m + 1 = 5$, the equation is $y^2 = a^{\frac{8}{5}} x^{\frac{2}{5}} - x^2$; which belongs to a line of the 10th order.

In general, if m be an even number, the order of the curve is $m + 1 \times 2$; but if m be an odd number, it is $m + 1$ ſimply.

XI.

In the ſame manner that the ſolid of greateſt attraction has been found, may a great *class* of ſimilar problems be reſolved. Whenever the property that is to exiſt in its greateſt or leaſt degree, belongs to all the points of a plane figure, or to all the points of a ſolid, given in magnitude, the queſtion is reduced to the determination of the locus of a certain equation, juſt as in the preceding example.

LET it, for instance, be required to find a solid given in magnitude, such, that from all the points in it, straight lines being drawn to any assigned number of given points, the sum of the squares of all the lines so drawn shall be a *minimum*. It will be found, by reasoning as in the case of the solid of greatest attraction, that the superficies bounding the required solid must be such that the sum of the squares of the lines drawn from any point in it, to all the given points, must be always of the same magnitude. Now, the sum of the squares of the lines drawn from any point to all the given points, may be shewn by plane geometry to be equal to the square of the line drawn to the centre of gravity of these given points, multiplied by the number of points, together with a given space. The line, therefore, drawn from any point in the required superficies to the centre of gravity of the given points, is given in magnitude, and therefore the superficies is that of a sphere, having for its centre the centre of gravity of the given points.

THE magnitude of the sphere is next determined from the condition, that its solidity is given.

IN general, if x , y , and z , are three rectangular co-ordinates that determine the position of any point of a solid given in magnitude, and if the value of a certain function Q , of x , y and z , be computed for each point of the solid, and if the sum of all these values of Q added together, be a maximum or a minimum, the solid is bounded by a superficies in which the function Q is every where of the same magnitude. That is, if the triple integral $\int x \int y \int Q z$ be the greatest or least possible, the superficies bounding the solid is such that $Q = A$, a constant quantity.

THE same holds of plane figures; the proposition is then simpler, as there are only two co-ordinates, so that $\int x \int Q y$ is
the

the quantity that is to be a maximum or a minimum, and the line bounding the figure is defined by the equation $Q = A$.

ALL the questions, therefore, which come under this description, though they belong to an order of problems, which requires in general the application of one of the most refined inventions of the New Geometry, the *Calculus Variationum*, form a particular division admitting of resolution by much simpler means, and directly reducible to the construction of loci.

IN these problems also, the synthetical demonstration will be found extremely simple. In the instance of the solid of greatest attraction this holds remarkably. Thus, it is obvious, that (Fig. 1.) any particle of matter placed without the curve ACBH, will attract the particle at A in the direction AB, less than any of the particles in that curve, and that any particle of matter within the curve, will attract the particle at A more than any particle in the curve, and more, *à fortiori*, than any particle without the curve. The same is true of the whole superficies of the solid. Now, if the figure of the solid be any how changed, while its quantity of matter remains the same, as much matter must be expelled from within the surface, at some one place C, as is accumulated without the surface at some other point H. But the action of any quantity of matter within the superficies ACBH on A, is greater than the action of the same without the superficies ACBH. The solid ACBH, therefore, by any change of its figure, must lose more attraction than it gains; that is, its attraction is diminished by every such change, and therefore it is itself the solid of greatest attraction. Q. E. D.

XII.

THE preceding theorems relate to the solids, which, of all solids whatsoever of a given content, have the greatest attraction in a given direction. It may be interesting also to know, among bodies of a given kind, and a given solid content, for example, among cones, cylinders, or parallelepipeds, given in magnitude, which has the greatest attractive power, in the direction of a certain straight line. We shall begin with the cone.

LET ABC (Fig. 5.) be a cone of which the axis is AD, required to find the angle BAC, when the force which the cone exerts, in the direction AD, on the particle A at its vertex, is greater than that which any other cone of the same solid content, can exert in the direction of its axis, on a particle at its vertex.

IT is known, if π be the femicircumference of the circle of which the radius is 1, that is, if $\pi = 3.14159$, &c. that the attraction of the cone ABC, on the particle A, in the direction

AD, is $= 2\pi \times \left(AD - \frac{AD^2}{AB} \right)$. (SIMPSON'S FLUXIONS, vol. ii. Art. 377.)

LET $AD = x$, $AB = z$, the solid content of the cone $= m^3$, and its attraction $= A$.

THEN $A = 2\pi \left(x - \frac{x^2}{z} \right)$, and $\pi x (z^2 - x^2) = 3m^3$.

THE quantity $x - \frac{x^2}{z}$, is to be a maximum, and therefore,

$$\dot{x} - \frac{2xz\dot{x} - x^2\dot{z}}{z^2} = 0, \text{ or } z^2 - 2xz + x^2 \cdot \frac{\dot{z}}{x} = 0.$$

AGAIN,

AGAIN, from the equation $\pi x (z^2 - x^2) = 3m^3$, we have
 $2xz\dot{z} + z^2\dot{x} - 3x^2\dot{x} = 0$, and $\frac{\dot{z}}{z} = \frac{3x^2 - z^2}{2xz}$, and by substituting this value of $\frac{\dot{z}}{z}$ in the former equation, we have

$$z^2 - \frac{5}{2}xz + \frac{3}{2} \cdot \frac{x^3}{z} = 0.$$

As this equation is homogeneous, if we make $\frac{x}{z} = u$, we will obtain an equation involving u only, and therefore determining the ratio of z to x , or of AB to AD. Substituting, accordingly, uz for x in the last equation, we have

$$z^2 - \frac{5}{2}uz^2 + \frac{3}{2}u^3z^2 = 0, \text{ and } 1 - \frac{5}{2}u + \frac{3}{2}u^3 = 0.$$

THIS equation is obviously divisible by $u - 1$, and when so divided, gives $\frac{3}{2}u^2 + \frac{3}{2}u - 1 = 0$, or $u^2 + u = \frac{2}{3}$, whence

$$u = -\frac{1}{2} \pm \sqrt{\frac{11}{12}}.$$

THIS is the value of $\frac{x}{z}$, and as $\frac{x}{z}$ must be less than unity, because AB is greater than AD, the negative value of u , or $-\frac{1}{2} - \sqrt{\frac{11}{12}}$, is excluded; so that $u = -\frac{1}{2} + \sqrt{\frac{11}{12}} = .45761$ nearly.

Now $u = \frac{AD}{AB} =$ the cosine of the angle BAD, or half the angle of the cone; therefore that angle = $62^\circ.46'$ nearly.

As

As the tangent of $62^{\circ}.46'$ is not far from being double of the radius, therefore the cone of greatest attraction has the radius of its base nearly double of its altitude.

To compare the attraction of this cone with that of a sphere containing the same quantity of matter, we must express the attraction in terms of u , the ratio of x to z , which has now been found.

$$\text{BECAUSE } \pi x (z^2 - x^2) = 3m^3, \text{ and } z = \frac{x}{u}, \pi x \left(\frac{x^2}{u^2} - x^2 \right) = \\ \pi x^3 \left(\frac{1 - u^2}{u^2} \right) = 3m^3, \text{ and } x = m \cdot \sqrt[3]{\frac{3u^2}{\pi(1-u^2)}}.$$

$$\text{Now, we have } A = 2\pi \left(x - \frac{x^2}{z} \right), \text{ and since } \frac{x}{z} = u, \frac{x^2}{z} = \\ m u \sqrt[3]{\frac{3u^2}{\pi(1-u^2)}}, \text{ and } A = 2\pi \left(m \cdot \sqrt[3]{\frac{3u^2}{\pi(1-u^2)}} - m u \cdot \sqrt[3]{\frac{3u^2}{\pi(1-u^2)}} \right) \\ = 2\pi m \cdot (1-u) \sqrt[3]{\frac{3u^2}{\pi(1-u^2)}}; \text{ wherefore, } A^3 = 8\pi^3 m^3 (1-u)^3 \\ \times \frac{3u^2}{\pi(1-u^2)} = 24\pi^2 m^3 \cdot \frac{u^2(1-u)^2}{1+u}.$$

BUT if A' be the attraction of a sphere of which the mass is m^3 , on a particle at its surface, $A' = m \sqrt[3]{\frac{16\pi}{9}}$, and $A'^3 = m^3 \cdot \frac{16\pi^2}{9}$. Therefore $A^3 : A'^3 :: \frac{24u^2(1-u)^2}{1+u} \cdot \frac{16}{9} :: \frac{27u^2(1-u)^2}{2(1+u)} : 1$; and consequently $A : A' :: 3\sqrt[3]{\frac{u^2(1-u)^2}{2(1+u)}} : 1$.

IF, in this expression, we substitute $.45761$ for u , we shall have $A : A' :: .82941 : 1$, so that the attraction of the cone, when

when a maximum is about $\frac{4}{5}$ of the attraction of a sphere of equal solidity.

XIII.

OF all the cylinders given in mass, or quantity of matter, to find that which shall attract a particle, at the extremity of its axis, with the greatest force.

LET DF (Fig. 6.) be a cylinder of which the axis is AB, if AC be drawn, the attraction of the cylinder on the particle A is $2\pi \times (AB + BC - AC)$ *, and we have therefore to find when $AB + BC - AC$ is a maximum, supposing $AB \cdot BC^2$ to be equal to a given solid.

LET $AB = x$, $BC = y$, then $AC = \sqrt{x^2 + y^2}$, and the quantity that is to be a maximum is $x + y - \sqrt{x^2 + y^2}$. We have

$$\text{therefore } \dot{x} + \dot{y} - \frac{x\dot{x} + y\dot{y}}{\sqrt{x^2 + y^2}} = 0, \text{ and } (\dot{x} + \dot{y}) (x^2 + y^2)^{\frac{1}{2}} =$$

$$x\dot{x} + y\dot{y}, \text{ or } \left(1 + \frac{y}{x}\right) (x^2 + y^2)^{\frac{1}{2}} = x + y \cdot \frac{y}{x}.$$

BUT since $\pi x y^2 = m^3$, $2xy\dot{y} + y^2\dot{x} = 0$, or $2x\dot{y} = -y\dot{x}$,

$$\text{and } \frac{\dot{y}}{x} = -\frac{y}{2x}.$$

THEREFORE

* PRINCIP. Lib. I. Prop. 91. Also SIMPSON'S Fluxions, vol. II. § 379. In the former, the constant multiplier 2π is omitted, as it is in some other of the theorems relating to the attraction of bodies. This requires to be particularly attended to, when these propositions are to be employed for comparing the attraction of solids of different species.

THEREFORE $\left(1 - \frac{y}{2x}\right) \cdot (x^2 + y^2)^{\frac{1}{2}} = x - y \cdot \frac{y}{2x}$, or
 $(2x - y) (x^2 + y^2)^{\frac{1}{2}} = 2x^2 - y^2$.

As this equation is homogeneous, if we make $\frac{y}{x} = u$, or $y = ux$, both x and y may be exterminated. For we have by substituting ux for y , $(2x - ux) (x^2 + u^2x^2)^{\frac{1}{2}} = 2x^2 - u^2x^2$, or $(2x^2 - ux^2) \cdot (1 + u^2)^{\frac{1}{2}} = 2x^2 - u^2x^2$, and dividing by x^2 , $(2 - u) \cdot (1 + u^2)^{\frac{1}{2}} = 2 - u^2$; whence squaring both sides, $(4 - 4u + u^2) (1 + u^2) = 4 - 4u^2 + u^4$.

FROM this, by multiplying and reducing, we get $4u^2 - 9u = -4$, or $u^2 - \frac{9}{4}u = -1$; and $u = \frac{9 \pm \sqrt{17}}{8}$.

2. THE two values of u in this formula create an ambiguity which cannot be removed without some farther investigation. If A be the attraction of the cylinder, then $A = 2\pi(x + y - \sqrt{x^2 + y^2})$, into which expression, if we introduce u , and exterminate both x and y , by help of the equations $\pi xy^2 = m^3$, and $\frac{y}{x} = u$, we get $A = 2\pi^{\frac{2}{3}}m \frac{1 + u - \sqrt{1 + u^2}}{u^{\frac{2}{3}}}$.

NOTWITHSTANDING the radical sign in this formula, there is but one value of A , corresponding to each value of u , as the positive root of $\sqrt{1 - u^2}$ is not applicable to the physical problem.

blem. This is evident, because the attraction must vanish both when $y = 0$, and when $x = 0$; that is, both when u is nothing, and when it is infinite. This can only happen when $\sqrt{1+u^2}$ is negative.

FARTHER, the value of A is always positive (as it ought to be), $1+u$ being greater than $\sqrt{1+u^2}$, because it is the square-root of $1+2u+u^2$.

3. PERHAPS the relation between A and u will be best conceived, by supposing A to be the ordinate of a curve in which the abscissæ are represented by the successive values of u . Thus, if OP (Fig. 7.) = u , and $PM = A$, the locus of M is a curve of the figure OMM' , which intersects the axis at O , and has the ordinate PM a maximum, when $OP = \frac{9-\sqrt{17}}{8}$; beyond PM' the curve has a point M' of contrary flexure, where it becomes convex toward the axis OR , and afterwards approaches OR continually. It has also another branch $mm'n$, corresponding to the affirmative values of $\sqrt{1+u^2}$, which has the perpendicular OQ for an asymptote; and has the ordinate $P'm'$ a minimum, when $u = \frac{9+\sqrt{17}}{8}$. After passing the point where $P'm'$ is a minimum, this branch of the curve recedes continually from the axis OR . Besides these, there are other two branches of the same curve, on the opposite side of OQ , answering to the negative values of u . It is, however, only the first-mentioned of these four branches that is connected with the mechanical question considered here.

THE attraction is a maximum, therefore, when $u = \frac{9 - \sqrt{17}}{8}$,

that is, when y is to x , or the radius of the base of the cylinder, to its altitude, as $9 - \sqrt{17}$ to 8, or as 5 to 8 nearly. Therefore also the diameter of the base is to the altitude, when the attraction of the cylinder is greatest, as $9 - \sqrt{17}$ to 4, or as 5 to 4 nearly.

5. THE attraction of the cylinder, when a maximum is now to be compared with that of a sphere of equal solid content.

FIRST, to compute the quantity $\frac{1 + u - \sqrt{1 + u^2}}{u^{\frac{2}{3}}}$, when

$$u = \frac{9 - \sqrt{17}}{8} = .6096, \text{ since } u^2 = .37161, 1 + u^2 = 1.37161,$$

and $\sqrt{1 + u^2} = 1.17116$; so that $1 + u - \sqrt{1 + u^2} = .43844$.

ALSO because $u^2 = .37161$, $u^{\frac{2}{3}} = .718945$; and therefore

$$\frac{1 + u - \sqrt{1 + u^2}}{u^{\frac{2}{3}}} = \frac{4384}{7189}. \text{ Therefore } A = 2\pi^{\frac{2}{3}} m \cdot \frac{1 + u - \sqrt{1 + u^2}}{u^{\frac{2}{3}}}$$

$$= 2\pi^{\frac{2}{3}} m \times \frac{4384}{7189}.$$

Now, if A' be the attraction of a sphere of the solidity m ,

$$A' = \pi^{\frac{2}{3}} m \times \left(\frac{16}{9}\right)^{\frac{1}{3}}, \text{ and } A : A' :: \frac{2 \times 4384}{7189} : \left(\frac{16}{9}\right)^{\frac{1}{3}} ::$$

$$\frac{8768}{7189} : 1.2114,$$

$\frac{8768}{7189} : 1.2114$, or as 1218 to 1211.4; so that the attraction of

the cylinder, even when its form is most advantageous, does not exceed that of a sphere, of the same solid content, by more than a hundred and eighty-third part.

6. IN a note on one of the letters of G. L. LE SAGE, published by M. PREVOST of Geneva *, the following theorem is given concerning the attraction of a cylinder and a sphere: If a cylinder be circumscribed about a sphere, the particle placed in the extremity of the axis of the cylinder, or at the point of contact of the sphere, and the base of the cylinder, is attracted equally by the sphere, and by that portion of the cylinder which has for its altitude two-thirds of the diameter of the sphere, and of which the solidity is therefore just equal to that of the sphere.

WE may investigate this theorem, by seeking the altitude of such a part of the circumscribing cylinder as shall have the same attraction with the sphere at the point of contact. If r be the radius of the sphere, the attraction at any point of

its surface, is $\frac{4\pi r}{3}$; and if x be the altitude of the cylinder,

and the radius of its base r , then its attraction on a particle at the extremity of its axis is $2\pi(x+r-\sqrt{x^2+r^2})$. Since these

attractions are supposed equal, $2\pi(x+r-\sqrt{x^2+r^2}) = \frac{4\pi r}{3}$,

and $x+r-\sqrt{x^2+r^2} = \frac{2r}{3}$, whence $\frac{2rx}{3} = \frac{8r^2}{9}$, and $x = \frac{4r}{3}$.

D d 2 THE

* NOTICE de la vie de G. L. LE SAGE de Genève, par P. PREVOST, p. 391.

THE altitude of the cylinder is therefore $\frac{4}{3}$ of the radius, or $\frac{2}{3}$ of the diameter of the sphere, which is LE SAGE'S Theorem.

THIS cylinder is also known to be equal in solidity to the sphere; but its attraction is not greater than that of the latter, because the proportion of its altitude to the diameter of its base is not that which gives the greatest attraction. Its altitude is to the diameter of its base, as $\frac{4}{3}r$ to $2r$, or 4 to 6; in order to have the greatest effect, it must be as 4 to 5 nearly, (§ 3.).

NOTWITHSTANDING, therefore, that the form of the one of these cylinders is considerably different from that of the other, their attractions are very nearly equal; the one of them being the same with that of the sphere, and the other greater than it by about the 183d part. On each side of the form which gives the maximum of attraction, there may be great variations of figure, without much change in the attracting force. A similar property belongs to all quantities near their greatest or least state, but seems to hold especially in what regards the attraction of bodies.

XIV.

IN considering the attraction of the Mountain Shehallien, in such a manner as to make a due allowance for the heterogeneity of the mass, it became necessary to determine the attraction of a half cylinder, or of any sector of a cylinder, on a point situated in its axis, in a given direction, at right angles

to

to that axis. The solution of this problem is much connected with the experimental inquiries concerning the attraction of mountains, and affords examples of maxima of the kind that form the principal object of this paper. The following lemma is necessary to the solution.

LET the quadrilateral DG (Fig. 8.) be the indefinitely small base of a column DH, which has everywhere the same section, and is perpendicular to its base DG.

LET A be a point at a given distance from D, in the plane DG; it is required to find the force with which the column DH attracts a particle at A, in the direction AD.

LET the distance AD = r , the angle DAE = ϕ , DE (supposed variable) = y , and let EF be a section of the solid parallel, and equal to the base DG; and let the area of DG = m^2 .

THE element of the solid DF is $m^2 \dot{y}$; and since DE, or $y = r \tan \phi$, $\dot{y} = r \frac{\dot{\phi}}{\cos^2 \phi}$, so that the element of the

$$\text{solid} = m^2 r \cdot \frac{\dot{\phi}}{\cos^2 \phi}.$$

THIS quantity divided by AE², that is, since AE : AD :: 1 : $\cos \phi$, by $\frac{r^2}{\cos^2 \phi}$, gives the element of the attraction in the direc-

tion AE equal to $\frac{m^2 r \dot{\phi}}{\cos^2 \phi} \times \frac{\cos^2 \phi}{r^2} = \frac{m^2 \dot{\phi}}{r}$. To reduce this to the

direction AD, it must be multiplied into the cosine of the angle DAE or ϕ , so that the element of the attraction of the column

in the direction AD is $\frac{m^2}{r} \dot{\phi} \cos \phi$, and the attraction itself =

$$\frac{m^2}{r} \int \dot{\phi} \cos \phi = \frac{m^2}{r} \sin \phi.$$

WHEN.

WHEN ϕ becomes equal to the whole angle subtended by the column, the total attraction is equal to the area of the base divided by the distance, and multiplied by the sine of the angle of elevation of the column.

IF the angle of elevation be 30° , the attraction of the column is just half the attraction it would have, supposing it extended to an infinite height.

IN this investigation, m^2 is supposed an infinitesimal; but if it be of a finite magnitude, provided it be small, this theorem will afford a sufficient approximation to the attraction of the column, supposing the distance AD to be measured from the centre of gravity of the base, and the angle ϕ to be that which is subtended by the axis of the column, or by its perpendicular height above the base.

XV.

LET the semicircle CBG (Fig. 9.), having the centre A, be the base of a half cylinder standing perpendicular to the horizon, AB a line in the plane of the base, bisecting the semicircle, and representing the direction of the meridian; it is required to find the force with which the cylinder attracts a particle at A, in the direction AB, supposing the radius of the base, and the altitude of the cylinder to be given.

LET DF be an indefinitely small quadrilateral, contained between two arches of circles described from the centre A, and two radii drawn to A; and let a column stand on it of the same height with the half cylinder, of which the base is the semicircle CBG. Let $z =$ the angle BAD, the azimuth of D; $v =$ the vertical angle subtended by the column on DF; $a =$
the

the height of that column, or of the cylinder, $AD = x$, AB , the radius of the base, $= r$.

By the last proposition, the column standing on DF , exerts on A an attraction in the direction AD , which is $= \frac{Dd \times Df}{AD} \times \sin v$.

Now $Dd = \dot{x}$, $Df = x \dot{z}$, and $Dd \times Df = \dot{x} z \dot{x}$. Therefore the attraction in the direction AD is $\frac{x \dot{x} z}{x} \times \sin v = \dot{x} z \sin v$, and reduced to the direction AB , it is $\dot{x} z \sin v \times \cos z$.

THIS is the element of the attraction of the cylindric shell or ring, of which the radius is AD or x , and the thickness \dot{x} ; and therefore integrated on the supposition that z only is variable, and x and v constant, it gives $\dot{x} \sin v \int z \cos z = \dot{x} \sin v \times \sin z$ for the attraction of the shell. When $z = 90$, and $\sin z = 1$, we have the attraction of a quadrant of the shell $= \dot{x} \sin v$, and therefore that of the whole semicircle $= 2 \dot{x} \sin v$.

NEXT, if x be made variable, and consequently v , we have $2 \int \dot{x} \sin v$ for the attraction of the semi-cylinder.

Now the angle v would have a for its sine if the radius were $\sqrt{a^2 + x^2}$, and so $\sin v = \frac{a}{\sqrt{a^2 + x^2}}$; wherefore the above expression is

$$\int \frac{2 a \dot{x}}{\sqrt{a^2 + x^2}} = 2 a L(x + \sqrt{a^2 + x^2}) + C; \text{ and as this must va-}$$

nish when $x = 0$, $2 a L a + C = 0$, and $C = -2 a L a$, so that
the

the fluent is $2 a L \frac{x + \sqrt{a^2 + x^2}}{a}$, which, when $x = r$, gives the

attraction of the femi-cylinder $= 2 a L \frac{r + \sqrt{a^2 + r^2}}{a}$.

THIS expression is very simple, and very convenient in calculation. It is probably needless to remark, that the logarithms meant are the hyperbolic.

XVI.

LET it be required to find the figure of a femi-cylinder given in magnitude, which shall attract a particle situated in the centre of its base with the greatest force possible, in the direction of a line bisecting the base.

THE attraction of the cylinder, as just demonstrated, is $2 a L \frac{r + \sqrt{r^2 + a^2}}{a}$; and because the solid is supposed to be given in magnitude, we may put $ar^2 = m^3$, or $a = \frac{m^3}{r^2}$; so that the formula

$$\text{above becomes } \frac{2 m^3}{r^2} L \frac{r + \sqrt{r^2 + \frac{m^6}{r^4}}}{\frac{m^3}{r^2}} = \frac{2 m^3}{r^2} L \frac{r^3 + \sqrt{r^6 + m^6}}{m^3}.$$

Now we may suppose $m = 1$, and then the attraction of the cylinder $= \frac{2}{r^2} L (r^3 + \sqrt{r^6 + 1})$.

THIS

THIS formula vanishes whether r be supposed infinitely great or infinitely small, and, therefore, there must be some magnitude of r in which its value will be the greatest possible.

IF r is very small in respect of 1, $\sqrt{1+r^6} = 1 + \frac{r^6}{2}$, and so $r^3 + \sqrt{1+r^6} = 1 + r^3 + \frac{r^6}{2}$, or simply $= 1 + r^3$. But $L(1+r^3)$, if r is very small in respect of 1, is r^3 ; and therefore the ultimate value of the formula, when r is infinitely small, is $\frac{2}{r^2} \times r^3 = 2r$, which is also infinitely small.

AGAIN, let r be infinitely great; then $\sqrt{r^6+1} = r^3$, and so the formula is $\frac{2}{r^2} L. 2r^3$, or $\frac{2 \times 3}{r^2} L. 2r$. But the logarithm of an infinitely great quantity r , is an infinite of an order incomparably less than r , as is known from the nature of logarithms, (GREG. FONTANÆ Disquisitiones Phys. Math. de Infinito Logarithmico, Theor. 4.); so that $\frac{6}{r^2} L. 2r$ is less than $\frac{6r}{r^2}$, or than $\frac{6}{r}$. But $\frac{6}{r}$ is infinitely small, r being infinitely great, and therefore, when the radius of the cylinder becomes infinitely great, its solid content remaining the same, its attraction is less even than an infinitesimal of the first order.

THE determination of the maximum, by the ordinary method, leads to an exponential equation of considerable difficulty, if an accurate solution is required. It is, however, easily found

by trial, that, when the function $\frac{1}{r^2} L(r^3 + \sqrt{1+r^6})$ is a maximum, r is nearly $= \frac{6}{5}$. Therefore, because $a = \frac{1}{r^2} = \frac{25}{36}$, r is nearly to a as $\frac{6}{5}$ to $\frac{25}{36}$, or as 216 to 125; and this of consequence, is, nearly, the ratio of the radius of the base, to the altitude of the half-cylinder, when its attraction, estimated according to the hypothesis of the problem, is the greatest possible.

XVII.

To determine the oblate spheroid of a given solidity which shall attract a particle at its pole with the greatest force.

LET there be an oblate spheroid generated by the revolution of the ellipse $ADBE$ (Pl. 7. Fig. 10.), about the conjugate axis AB , and let F be the focus; then if AF be drawn, and the arch CG described from the centre A , the force with which the spheroid draws a particle at A , in the direction AC , is $\frac{4\pi \cdot AC \cdot CD^2}{CF^3} (CF - CG^*)$. (MACLAURIN'S FLUXIONS, § 650).

LET this force $= F$, $AC = a$, $CD = b$, the angle $CAF = \phi$; then $CF = a \tan \phi$, and $F = \frac{4\pi a b^2}{a^3 \tan \phi^3} (\tan \phi - \phi) a = \frac{4\pi b^2}{a} \frac{\tan \phi - \phi}{\tan \phi^3}$.

Now if m^3 be the solidity of the spheroid, since that solidity is two-thirds of the cylinder, having CD for the radius of its base,

* THE multiplier 2π , omitted by MACLAURIN, is restored as above, § XIII.

bafe, and AB for its altitude; therefore $m^3 = \frac{2}{3} \times \pi b^2 \times 2a$

$$= \frac{4}{3} \pi a b^2; \text{ so that } b^2 = \frac{m^3}{\frac{4}{3} \pi a} = \frac{3 m^3}{4 \pi a}, \text{ and } \frac{b^2}{a} = \frac{3 m^3}{4 \pi a^2}.$$

BUT because $AF : AC :: 1 : \text{cof } \phi$, or $b : a :: 1 : \text{cof } \phi$, $b^2 = \frac{a^2}{\text{cof } \phi^2}$, and $\frac{b^2}{a} = \frac{a}{\text{cof } \phi^2}$.

Now since $b^2 = \frac{a^2}{\text{cof } \phi^2}$, and also $b^2 = \frac{3 m^3}{4 \pi a}$, we have $\frac{a^2}{\text{cof } \phi^2} = \frac{3 m^3}{4 \pi a}$, and $a^3 = \frac{3 m^3}{4 \pi} \cdot \text{cof } \phi^2$, or if $\frac{3 m^3}{4 \pi} = n^3$, $a^3 = n^3 \cdot \text{cof } \phi^2$, and $a = n \text{cof } \phi^{\frac{2}{3}}$.

$$\text{HENCE, as } \frac{b^2}{a} = \frac{a}{\text{cof } \phi^2}, \frac{b^2}{a} = \frac{n \text{cof } \phi^{\frac{2}{3}}}{\text{cof } \phi^2} = \frac{n}{\text{cof } \phi^{\frac{4}{3}}}.$$

By substituting this value of $\frac{b^2}{a}$ in the value of F, we have F

$$= \frac{4 \pi n}{\text{cof } \phi^{\frac{4}{3}}} \cdot \frac{\tan \phi - \phi}{\tan \phi^3}, \text{ and because } \tan \phi^3 = \frac{\text{fin } \phi^3}{\text{cof } \phi^3}, F =$$

$$\frac{2 \pi n \cdot (\tan \phi - \phi) \cdot \text{cof } \phi^3}{\text{fin } \phi^3 \times \text{cof } \phi^{\frac{4}{3}}} = \frac{2 \pi n (\tan \phi - \phi) \text{cof } \phi^{\frac{5}{3}}}{\text{fin } \phi^3} =$$

$$2 \pi n (\tan \phi - \phi) \cdot \text{cof } \phi^{\frac{5}{3}} \cdot \text{fin } \bar{\phi}^3.$$

Now when the product of any number of factors is a maximum, if the fluxion of each factor be divided by the factor itself,

self, the sum of the quotients is equal to nothing. Therefore

$$\frac{\frac{\dot{\phi}}{\text{cof } \phi^2} - \dot{\phi}}{\tan \phi - \phi} + \frac{5 \text{ cof } \phi^{\frac{2}{3}} \cdot \dot{\text{cof}} \phi}{3 \text{ cof } \phi^{\frac{5}{3}}} - \frac{3 \text{ fin } \phi \cdot \dot{\text{fin}} \phi}{\text{fin } \phi^3} = 0, \text{ or}$$

$$\frac{\dot{\phi} (1 - \text{cof } \phi^2)}{\text{cof } \phi^2 (\tan \phi - \phi)} - \frac{5 \dot{\phi} \text{ fin } \phi}{3 \text{ cof } \phi} - \frac{3 \dot{\phi} \text{ cof } \phi}{\text{fin } \phi} = 0,$$

$$\text{and } \frac{\text{fin } \phi^2}{\text{cof } \phi^2 (\tan \phi - \phi)} - \frac{5 \text{ fin } \phi}{3 \text{ cof } \phi} - \frac{3 \text{ cof } \phi}{\text{fin } \phi} = 0;$$

$$\frac{\text{fin } \phi}{\text{cof } \phi (\tan \phi - \phi)} = \frac{5}{3} + 3 \frac{\text{cof } \phi^2}{\text{fin } \phi^2}, \text{ and } \frac{\tan \phi}{\tan \phi - \phi} =$$

$$\frac{5}{3} + 3 \cot \phi^2.$$

HENCE $\frac{3 \tan \phi}{5 + 9 \cot \phi^2} = \tan \phi - \phi$, and $\phi = \tan \phi -$

$$\frac{3 \tan \phi}{5 + 9 \cot \phi^2} = \frac{5 \tan \phi + 9 \tan \phi \cdot \cot \phi^2 - 3 \tan \phi}{5 + 9 \cot \phi^2} =$$

$$\frac{2 \tan \phi + 9 \cot \phi}{5 + 9 \cot \phi^2}.$$

$$\text{LET } \tan \phi = t, \text{ then } \phi = \frac{2t + \frac{9}{t}}{5 + \frac{9}{t^2}} = \frac{2t^3 + 9t}{5t^2 + 9} =$$

$\frac{t(9 + 2t^2)}{9 + 5t^2}$; which, therefore, is the value of ϕ when F is a maximum.

THE

THE value of ϕ , now found, is remarkable for being a near approximation to any arch of which t is the tangent, provided that arch do not exceed 45° . The less the arch is, the more near is the approximation; but the expression can only be considered as accurate when $\phi = 0$.

THIS will be made evident by comparing the fraction $\frac{t(9 + 2t^2)}{9 + 5t^2}$ with the series, that gives the arch in terms of the

tangent t , viz. $\phi = t - \frac{t^3}{3} + \frac{t^5}{5} - \frac{t^7}{7} +$, &c. The fraction

$\frac{t(9 + 2t^2)}{9 + 5t^2} = t - \frac{t^3}{3} + \frac{5t^5}{27} - \frac{5^2t^7}{3 \cdot 9^2} +$, &c. The two first

terms of these series agree; and in the third terms, the difference is inconsiderable, while t is less than unity; but the agreement is never entire, unless $t = 0$, when both series vanish.

THE attraction, therefore, or the gravitation at the pole of an oblate spheroid, is not a maximum, until the eccentricity of the generating ellipsis vanish, and the spheroid pass into a sphere.

FROM the circumstance of the value of ϕ above found, agreeing nearly with an indefinite number of arches, we must conclude, that when a sphere passes into an oblate spheroid, its attraction varies at first exceeding slowly, and continues to do so till its oblateness, or the eccentricity of the generating ellipsis, become very great. This may be shewn, by taking the value of F , and substituting in it that of ϕ , in terms of $\tan \phi$.

WE have $F = \frac{4\pi n}{\cos \phi^{\frac{4}{3}}} \cdot \frac{\tan \phi - \phi}{\tan \phi^3}$; and since $\phi = \tan \phi -$

$$\frac{\tan \phi^3}{3}$$

$\frac{\tan \phi^3}{3} + \frac{\tan \phi^5}{5} -$, &c. $\tan \phi - \phi = \frac{\tan \phi^3}{3} - \frac{\tan \phi^5}{5} +$, &c. and

$$F = \frac{4 \pi n}{\operatorname{cof} \phi^{\frac{4}{3}}} \left(\frac{\tan \phi^3}{3} - \frac{\tan \phi^5}{5} + \frac{\tan \phi^7}{7} \right) \frac{1}{\tan \phi^3} =$$

$\frac{4 \pi n}{\operatorname{cof} \phi^{\frac{4}{3}}} \left(\frac{1}{3} - \frac{\tan \phi^2}{5} + \frac{\tan \phi^4}{7} \right)$. When $\phi = 0$, $F = \frac{4 \pi n}{3}$;

and since $n = m \cdot \sqrt[3]{\frac{3}{4 \pi}}$, $F = \frac{4 \pi m}{3} \sqrt[3]{\frac{3}{4 \pi}} = m \sqrt[3]{\frac{6 \cdot 4 \pi^3 \cdot 3}{27 \cdot 4 \pi}} =$

$m \sqrt[3]{\frac{16 \pi^2}{9}}$, which is the attraction at the surface of a sphere of

the solidity m^3 , as was already shewn. This last is the conclusion we had to expect, the spheroid, when it ceases to have any oblateness, becoming of necessity a sphere.

It is evident also, that the variations of ϕ will but little affect the magnitude of F , while ϕ and $\tan \phi$ are small, as the least power of $\tan \phi$ that enters into the value of F is the square.

FOR, instead of $\operatorname{cof} \phi^{\frac{4}{3}}$, we may, when ϕ is very small, write

$$1 + \frac{2}{3} \tan \phi^2; \text{ so that } F = 4 \pi n \left(1 + \frac{2}{3} \tan \phi^2 \right) \left(\frac{1}{3} - \frac{\tan \phi^2}{5} + \frac{\tan \phi^4}{7} - \right), \text{ \&c.}$$

IF the oblateness of a spheroid diminish, while its quantity of matter remains the same, its attraction will increase till the oblateness vanish, and the spheroid become a sphere, when the attraction at its poles, as we have seen, becomes a maximum. If the polar axis continue to increase, the spheroid

roid becomes oblong, and the attraction at the poles again diminishes. This we may safely conclude from the law of continuity, though the oblong spheroid has not been immediately considered.

XVIII.

To find the force with which a particle of matter is attracted by a parallelepiped, in a direction perpendicular to any of its sides.

FIRST, let EM (Fig. II.), be a parallelepiped, having the thickness CE indefinitely small, A, a particle situated anywhere without it, and AB a perpendicular to the plane CDMN. The attraction in the direction AB is to be determined.

LET the solid EM be divided into columns perpendicular to the plane NE, having indefinitely small rectangular bases, and let CG be one of those columns.

IF the angle CAB, the azimuth of this column relatively to AB, be called z , CAD, its angle of elevation from A, e , and m^2 , the area of the little rectangle CF; then, as has been already shewn, the attraction of the column CG, in the direction AC, is

$\frac{m^2}{AC} \cdot \sin e$; and that same attraction, reduced to the direction

AB, is $\frac{m^2}{AC} \cdot \sin e \cdot \cos z$. This is the element of the attraction

of the solid, and if we call that attraction f , $f = \frac{m^2}{AC} \cdot \sin e \cdot \cos z$.

Now, if $AB = a$, because $1 : \cos z :: AC : AB$, $AC = \frac{a}{\cos z}$;

so that $f = \frac{m^2}{a} \cdot \sin e \cdot \cos z^2$.

BUT

BUT $BC = a \cdot \tan z$; and therefore KC , the fluxion of BC , is
 $= a \cdot \frac{\dot{z}}{\text{cof } z^2}$; if, then, $CE = n$, $m^2 = CE \times CK = n a \cdot \frac{\dot{z}}{\text{cof } z^2}$,

and substituting this for m^2 , we get $\dot{f} = n \dot{z} \cdot \text{fin } e$.

NEXT, to express $\text{fin } e$, in terms of z , if we make $E = \text{BAL}$, the angle subtended by the vertical columns, when it is greatest, or the inclination of the plane ADM , to the plane ACN , then we may consider the angle CAD , as measured by the side of a right angled spherical triangle, of which the other side is $90 - z$, and E the angle, adjacent to that side, and therefore $\tan e = \text{fin } (90 - z) \cdot \tan E = \text{cof } z \cdot \tan E$. But $\tan E = \tan \cdot \text{BAL} = \frac{BL}{BA} = \frac{b}{a}$, supposing BL , or $CD = b$.

THEREFORE $\tan e = \frac{b}{a} \text{cof } z$, or $\frac{\text{fin } e}{\text{cof } e} = \frac{b}{a} \cdot \text{cof } z$.

HENCE $\frac{\text{fin } e^2}{\text{cof } e^2} = \frac{b^2}{a^2} \cdot \text{cof } z^2$, or $\frac{\text{fin } e^2}{1 - \text{fin } e^2} = \frac{b^2}{a^2} \cdot \text{cof } z^2$, and

$\text{fin } e^2 = \frac{b^2}{a^2} \cdot \text{cof } z^2 - \text{fin } e^2 \cdot \frac{b^2}{a^2} \text{cof } z^2$; and therefore $\text{fin } e =$

$$\frac{\frac{b}{a} \cdot \text{cof } z}{\sqrt{1 + \frac{b^2}{a^2} \text{cof } z^2}}.$$

IF this value of $\text{fin } e$ be substituted for it, we have

$$\dot{f} = n \dot{z} \cdot \text{fin } e = \frac{b n \dot{z} \text{cof } z}{a \sqrt{1 + \frac{b^2}{a^2} \text{cof } z^2}}.$$

LET

LET $u = \sin z$, then $\dot{u} = \dot{z} \operatorname{cof} z$, and $\operatorname{cof} z^2 = 1 - u^2$; where-

fore, again, by substitution, $f = \frac{bn\dot{u}}{a\sqrt{1 + \frac{b^2}{a^2}(1-u^2)}} =$

$\frac{bn\dot{u}}{\sqrt{a^2 + b^2 - b^2u^2}}$. Let $a^2 + b^2$, or $AL^2 = c^2$, then $f =$

$\frac{bn\dot{u}}{\sqrt{c^2 - b^2u^2}} = \frac{bn\dot{u}}{c\sqrt{1 - \frac{b^2}{c^2}u^2}}$

If, therefore, ϕ be such an arch, that $\frac{bu}{c} = \sin \phi$, $\frac{b\dot{u}}{c} =$

$\phi \cdot \operatorname{cof} \phi$, and $\sqrt{1 - \frac{b^2}{c^2}u^2} = \operatorname{cof} \phi$, then $\frac{bn\dot{u}}{c\sqrt{1 - \frac{b^2}{c^2}u^2}} =$

$\frac{n\phi \operatorname{cof} \phi}{\operatorname{cof} \phi} = n\phi$. Thus, $f = n\phi$, and $f = n\phi + B$, B being a constant quantity.

Now, since $\sin \phi = \frac{bu}{c} = \frac{b}{c} \sin z$, ϕ is nothing when z is nothing; and as f may be supposed to begin when z begins, we have likewise $B = 0$; and, $f = n\phi = n$ multiplied into an arch, the sine of which is to the sine of z , in the given ratio of c to

b . Or f is such that $= \sin \frac{f}{n} = \frac{b}{c} \times \frac{BC}{AC} = \frac{BL}{AL} \times \frac{BC}{AC}$.

HENCE this rule, multiply the sine of the greatest elevation, into the sine of the greatest azimuth of the solid; the arch of which this is the sine, multiplied into the thickness of the solid, is equal to its attraction in the direction of the perpendicular from the point attracted.

THE height and the length of the parallelepiped, are, therefore, similarly involved in the expression of the force, as they ought evidently to be from the nature of the thing.

XIX.

THIS theorem leads directly to the determination of the attraction of a pyramid, having a rectangular base, on a particle at its vertex. For if we consider EM (Fig. 11.) as a slice of a pyramid parallel to its base, A being the vertex, then the slice behind EM subtending the same angles that it does, will have its force of attraction $= n' \phi$, n' being its thickness, and so of all the rest; and, therefore, the sum of all these attractions, if p denote the whole height of the solid, or the perpendicular from A on its base, will be $p \phi$. But as $n \phi$ is only the attraction of the part HB, it must be doubled to give the attraction of the whole solid EM, which is, therefore, $2 n \phi$; and this must again be doubled, to give the attraction of the part which is on the side of AB, opposite to EM; thus the element of the attraction of the pyramid is $4 n \phi$, and the whole attraction corresponding to the depth p , is $4 p \phi$.

IF the solid is the frustum of a pyramid whose depth is p' , and vertex A, the angle ϕ being determined as before, the attraction on A is $4 p' \phi$.

If we suppose BC and BL to be equal, and therefore the angle BAL = the angle BAC, calling either of them η , then $\sin \phi = \sin \eta^2$, by what has been already shewn; and from this equation, as η is supposed to be given, ϕ is determined.

THIS expression for the attraction of an isosceles pyramid, having a rectangular base, may be of use in many computations concerning the attraction of bodies.

If the solidity of the pyramid be given, from the equations $f = 4 p \phi$, and $\sin \phi = \sin \eta^2$, we may determine η , and p , that is, the form of the pyramid when f is a maximum.

LET the solidity of the pyramid = m^3 , then p , being the altitude of the pyramid, and η half the angle at the vertex $p \tan \eta =$ half the side of the base, (which is a square), and therefore the area of the base = $4 p^2 \tan \eta^2$, and the solidity of

the pyramid $\frac{4}{3} p^3 \tan \eta^2$; so that $\frac{4}{3} p^3 \tan \eta^2 = m^3$.

Now $\tan \eta^2 = \frac{\sin \eta^2}{\cos \eta^2}$ and $\sin \phi = \sin \eta^2$, also $1 - \sin \phi =$

$1 - \sin \eta^2 = \cos \eta^2$, therefore $\tan \eta^2 = \frac{\sin \phi}{1 - \sin \phi}$; so that $m^3 =$

$\frac{4}{3} p^3 \cdot \frac{\sin \phi}{1 - \sin \phi}$, and $p^3 = \frac{3}{4} m^3 \cdot \frac{1 - \sin \phi}{\sin \phi}$, or $p =$

$m^3 / \sqrt[3]{\frac{3(1 - \sin \phi)}{4 \sin \phi}}$; we have, therefore, f , that is $4 p \phi =$

$4 m \phi \sqrt[3]{\frac{3 \cdot (1 - \sin \phi)}{4 \sin \phi}}$. This last is, therefore, a maximum

by hypothesis; and, consequently, its cube, or $64 m^3 \phi^3 \times \frac{3(1 - \sin \phi)}{4 \sin \phi}$, or omitting the constant multipliers, $\phi^3 \cdot \frac{1 - \sin \phi}{\sin \phi}$ must be a maximum.

If we take the fluxion of each of these multipliers, and divide it by the multiplier itself, and put the sum equal to nothing, we shall have, $\frac{3\dot{\phi}}{\phi} - \frac{\dot{\phi} \cos \phi}{1 - \sin \phi} - \frac{\dot{\phi} \cos \phi}{\sin \phi} = 0$, or $\frac{3}{\phi} = \frac{\cos \phi}{1 - \sin \phi} + \frac{\cos \phi}{\sin \phi} = \frac{\cos \phi \cdot \sin \phi + \cos \phi - \cos \phi \cdot \sin \phi}{\sin \phi (1 - \sin \phi)} = \frac{\cos \phi}{\sin \phi (1 - \sin \phi)}$, and inverting these fractions $\frac{\phi}{3} = \frac{\sin \phi (1 - \sin \phi)}{\cos \phi} = \tan \phi (1 - \sin \phi)$, or $\phi = 3 \tan \phi (1 - \sin \phi)$.

THE solution of this transcendental equation may easily be obtained, by approximation, from the trigonometric tables, if we consider that $1 - \sin \phi$ is the covered sine of ϕ . Thus taking the logarithms, we have $L \phi = L . 3 + L . \tan \phi + L . \text{coverf. } \phi$. From which, by trial, it will soon be discovered, that ϕ is nearly equal to an arch of 48° . To obtain a more exact value of ϕ , let $\phi = \text{arc}(48^\circ + \beta)$, β being a number of minutes to be determined. Because $\text{arc}.48^\circ = .8377580$, and $\text{arc}(48^\circ + \beta) = .8377580 + .0002909 \beta$, therefore $\log . \text{arc}(48^\circ + \beta) = 9.9231186 + .0001506 \beta$.

In the same manner,

$$L \tan (48^\circ + \beta) = 0.0455626 + .0002540 \beta,$$

$$\text{and } L. \text{ coverf. } (48^\circ + \beta) = 9.4096883 - .0003292 \beta$$

$$\begin{aligned} L 3 &= \frac{0.4771213}{\text{Sum}} \\ &= \frac{9.9323722 - .0000752 \beta}{\text{Sum}} \end{aligned}$$

$$\begin{aligned} \text{Subtract Log arc } (48^\circ + \beta) &= \frac{9.9231186 + .0001506 \beta}{\text{Remainder}} \\ \text{Remainder} &= \frac{.0092536 - .0002258 \beta}{\text{Remainder}} = 0. \end{aligned}$$

$$\text{Whence, } \beta = \frac{92536}{2258} = 41' \text{ nearly.}$$

A SECOND approximation will give a correction = $-20''$,

so that $\phi = \text{arc. } 48^\circ. 40' \frac{2}{3}$; and since $\sin \phi = \sin \eta^2$, $\sin \eta =$

$\sqrt{\sin \phi}$, so that $\eta = 76^\circ. 30'$, and 2η , or the whole angle of the pyramid = 153° .

AN isosceles pyramid, therefore, with a square base, will attract a particle at its vertex with greatest force, when the inclination of the opposite planes to one another is an angle of 153° .

XX.

To return to the attraction of the parallelepiped, it may be remarked, that the theorem concerning this attraction already investigated, § XVIII. though it applies only to the case when the parallelepiped is indefinitely thin, leads, nevertheless, to some very general conclusions. It was shewn, that the attraction which the solid EL (Fig. 11.) exerts on the particle A, in the direction AB, is $n \cdot \phi$, ϕ being an arch, such that $\sin \phi = \sin BAC \times \sin BAL = \sin z \cdot \sin E$; and, therefore, if B be the centre of

a rectangle, of which the breadth is $2 BC$, and the height $2 BL$, the attraction of that plane, or of the thin solid, having that plane for its base, and n , for its thickness, is $4n \cdot \phi$. Now, ϕ , which is thus proportional to the attraction of the plane, is also proportional to the spherical surface, or the angular space, subtended by the plane at the centre A .

FOR suppose PSQ (Fig. 12.) and OQ to be two quadrants of great circles of a sphere, cutting one another at right angles in Q ; let $QS = E$, and $QR = z$. Through S , and O the pole of PSQ , draw the great circle OST , and through P and R , the great circle PTR , intersecting OS in T . The spherical quadrilateral $SQRT$, is that which the rectangle CL (Fig. 11.) would subtend, if the sphere had its centre at A , if the point Q was in the line AB , and the circle PQ , in the vertical plane ABL .

Now, in the spherical triangle PST , right angled at S , $\text{cof } T = \text{cof } PS \times \text{fin } SPT = \text{fin } QS \times \text{fin } QR = \text{fin } E \times \text{fin } z$. But this is also the value of $\text{fin } \phi$, and therefore ϕ is the complement of the angle T , or $\phi = 90 - T$.

BUT the area of the triangle PQR , in which both Q and R are right angles, is equal to the rectangle under the arch QR , which measures the angle QPR , and the radius of the sphere. Also the area $SPT = \text{arc} \cdot (S + T + P - 180^\circ) r$; that is, because S is a right angle, $= \text{arc} \cdot (T + P - 90) \times r = \text{arc} \cdot (T + QR - 90) \times r$; and taking this away from the triangle PQR , there remains the area $QSTR = \text{arc} \cdot (QR - T - QR + 90^\circ) \times r = (90 - T) r = \phi \times r$. The arch ϕ , therefore, multiplied into the radius, is equal to the spherical quadrilateral $QSTR$, subtended by the rectangle BD .

THIS proposition is evidently applicable to all rectangles whatsoever. For when the point B , where the perpendicular from A meets the plane of the rectangle, falls anywhere, as in Fig. 15. then it may be shewn of each of the four rectangles BD ,

BD, BM, BM', BD', which make up the whole rectangle DM', that its attraction in the direction AB is expounded by the area of the spherical quadrilateral subtended by it, and, therefore, that the attraction of the whole rectangle MD', is expounded by the sum of these spherical quadrilaterals, that is, by the whole quadrilateral subtended by MD'. In the same manner, if the perpendicular from the attracted particle, were to meet the plane without the rectangle MD', the difference between the spherical quadrilaterals subtended by MC and M'C, would give the quadrilateral, subtended by the rectangle MD', for the value of the attraction of that rectangle.

THEREFORE, in general, *if a particle A, gravitate to a rectangular plane, or to a solid indefinitely thin, contained between two parallel rectangular planes, its gravitation, in the line perpendicular to those planes, will be equal to the thickness of the solid, multiplied into the area of the spherical quadrilateral subtended by either of those planes at the centre A.*

THE same may be extended to all planes, by whatever figure they be bounded, as they may all be resolved into rectangles of indefinitely small breadth, and having their lengths parallel to a straight line given in position.

THE gravitation of a point toward any plane, in a line perpendicular to it, is, therefore, equal to n , a quantity that expresses the intensity of the attraction, multiplied into the area of the spherical figure, or, as it may be called, the angular space subtended by the given plane.

THUS, in the case of a triangular plane, where the angles subtended at A, by the sides of the triangle, are a , b and c ; since EULER has demonstrated* that the area of the spherical triangle contained by these arches, is equal to the rectangle under

* Nov. Acta Petrop. 1792, p. 47.

der the radius, and an arch Δ , such that $\text{cof } \frac{1}{2} \Delta = \frac{1 + \text{cof } a + \text{cof } b + \text{cof } c}{4 \text{cof } \frac{1}{2} a \cdot \text{cof } \frac{1}{2} b \cdot \text{cof } \frac{1}{2} c}$; if Δ be computed, the attraction $= n \cdot \Delta$.

IN the case of a circular plane, our general proposition agrees with what Sir ISAAC NEWTON has demonstrated. If CFD (Fig. 13.) be a circle, BA a line perpendicular to the plane of it from its centre B; A, a particle anywhere in that line; the force with which A is attracted, in the direction AB, is $2\pi \left(1 - \frac{AB}{AD}\right)^*$,

in which the multiplier 2π is supplied, being left out in the investigation referred to, where a quantity only proportional to the attraction is required. Now $\frac{AB}{AD}$ is the cosine of the

angle BAD, and, therefore, $1 - \frac{AB}{AD}$ is its versed sine; and, therefore, if the arch GEK be described from the centre A, with the radius 1, and if the sine GH, and the chord EG be drawn, HE is the versed sine of BAD, and the attraction $= 2\pi EH$. But $2 \cdot EH = EG^2$, because 2 is the diameter of the circle GEK; therefore the attraction $= \pi \cdot EG^2 =$ the area of the circle of which EG is the radius, or the spherical surface included by the cone, which has A for its vertex, and the circle CFD for its base.

XXI.

* PRINCIP. Lib. i. Prop. 90.

XXI.

FROM the general proposition, that the attraction of any plane figure, whatever its boundary may be, in a line perpendicular to the plane, is at any distance proportional to the angular space, or to the area of the spherical figure which the plane figure subtends at that distance, we can easily deduce a demonstration of this other proposition, that whatever be the figure of any body, its attraction will decrease in a ratio that approaches continually nearer to the inverse ratio of the squares of the distances, as the distances themselves are greater. In other words, the inverse ratio of the squares of the distances, is the limit to which the law by which the attraction decreases, continually approaches as the distances increase, and with which it may be said to coincide when the distances are infinitely great.

THIS proposition, which we usually take for granted, without any other proof, I believe, then, some indistinct perception of what is required by the law of continuity, may be rigorously demonstrated from the principle just established.

LET B (Fig. 14.) be a body of any figure whatsoever, A a particle situated at a distance from B vastly greater than any of the dimensions of B, so that B may subtend a very small angle at A; from C, a point in the interior of the body, suppose its centre of gravity, let a straight line be drawn to A, and let A' be another point, more remote from B than A is, where a particle of matter is also placed.

THE directions in which A and A' gravitate to B, as they must tend to some point within B, must either coincide with AC, or make a very small angle with it, which will be always the less, the greater the distance.

LET the body B be cut by two planes, at right angles to AC, and indefinitely near to one another, so as to contain between them a slice or thin section of the body, to which A and A' may be considered as gravitating, nearly in the direction of the line AC perpendicular to that section.

THE gravitation of A, therefore, to the aforesaid section, will be to that of A' to the same, as the angular space subtended by that section at A, to the angular space subtended by it at A'. But these angular spaces, when the distances are great, are inversely as the squares of those distances, and therefore, also, the gravitation of A toward the section, will be to that of A', inversely as the squares of the distances of A and A' from the section. Now these distances may be accounted equal to CA and CA', from which they can differ very little, wherever the section is made.

THE gravitations of A and A' toward the said section, are, therefore, as $\frac{1}{AC^2}$ to $\frac{1}{A'C^2}$. And the same may be proved of the gravitation to all the other sections, or laminæ, into which the body can be divided by planes perpendicular to AC; therefore the sums of all these gravitations, that is, the whole gravitations of A to B, and of A' to B, will be in that same ratio, that is, as $\frac{1}{AC^2}$ to $\frac{1}{A'C^2}$, or inversely as the squares of the distances from C. Q. E. D.

IT is evident, that the greater the distances AC, A'C are, the nearer is this proposition to the truth, as the quantities rejected in the demonstration, become less in respect of the rest, in the same proportion that AC and A'C increase.

IT is here assumed, that the angular space subtended by the same plane figure, is inversely as the square of the distance.

This

This proposition may be proved to be rigorously true, if we consider the inverse ratio of the squares of the distances, as a limit to which the other ratio constantly converges.

It is a proposition also usually laid down in optics, where the *visible space* subtended by a surface, is the same with what we have here called the *angular space* subtended by it, or the portion of a spherical superficies that would be cut off by a line passing through the centre of the sphere, and revolving round the boundary of the figure. The centre of the sphere is supposed to coincide with the eye of the observer, or with the place of the particle attracted, and its radius is supposed to be unity.

THE propositions that have been just now demonstrated concerning the attraction of a thin plate contained between parallel planes, have an immediate application to such inquiries concerning the attraction of bodies, as were lately made by Mr CAVENDISH.

IN some of the experiments instituted by that ingenious and profound philosopher, it became necessary to determine the attraction of the sides of a wooden case, of the form of a parallelepiped, on a body placed anywhere within it. (Philosophical Transactions, 1798, p. 523.). The attraction in the direction perpendicular to the side, was what occasioned the greatest difficulty, and Mr CAVENDISH had recourse to two infinite series, in order to determine the quantity of that attraction. The determination of it, from the preceding theorems, is easier and more accurate.

LET MD' (Fig. 15.) represent a thin rectangular plate, A, a particle attracted by it, AB a perpendicular on the plane MD', NBC, LBL', two lines drawn through B parallel to the sides of the rectangle MD'. Let AC, AL, AN, AL', be drawn.

G g 2

THEN,

THEN, if we find ϕ such that $\sin \phi = \frac{BL}{AL} \times \frac{BC}{AC}$, the attraction of the rectangle CL is $n \cdot \phi$, n denoting the thickness of the plate.

So also, if $\sin \phi' = \frac{BL}{AL} \times \frac{BN}{AN}$, the attraction of LN is $= n \cdot \phi'$.

If $\sin \phi'' = \frac{BL'}{AN} \times \frac{BL'}{AL}$, the attraction of NL' is $= n \cdot \phi''$.

LASTLY, If $\sin \phi''' = \frac{BL'}{AL} \times \frac{BC}{AC}$, the attraction of L'C $= n \cdot \phi'''$.

THUS the whole effect of the plane MD', or $f = n(\phi + \phi' + \phi'' + \phi''')$.

WE may either suppose ϕ, ϕ' &c. defined as above, or by the following equations, where $\eta, \eta', \eta'',$ &c. denote the angles subtended by the sides of the rectangles that meet in B, beginning with BC, and going round by L, N and L' to C.

$$\sin \phi = \sin \eta \cdot \sin \eta'$$

$$\sin \phi' = \sin \eta' \cdot \sin \eta''$$

$$\sin \phi'' = \sin \eta'' \cdot \sin \eta'''$$

$$\sin \phi''' = \sin \eta''' \cdot \sin \eta$$

IF the computation is to be made by the natural sines, it will be better to use the following formulæ:

$$\sin \phi = \frac{1}{2} \operatorname{cosec}(\eta - \eta') - \frac{1}{2} \operatorname{cosec}(\eta + \eta')$$

$$\sin \phi' = \frac{1}{2} \operatorname{cosec}(\eta' - \eta'') - \frac{1}{2} \operatorname{cosec}(\eta' + \eta'')$$

$\sin \phi''$

$$\sin \phi'' = \frac{1}{2} \operatorname{cof}(\eta'' - \eta''') - \frac{1}{2} \operatorname{cof}(\eta'' + \eta''')$$

$$\sin \phi''' = \frac{1}{2} \operatorname{cof}(\eta''' - \eta) - \frac{1}{2} \operatorname{cof}(\eta''' + \eta).$$

By either of these methods, the determination of the attraction is reduced to a very simple trigonometrical calculation.

XXII.

THE preceding theorems will also serve to determine the attraction of a parallelepiped, of any given dimensions, in the direction perpendicular to its sides.

LET BF (Fig. 16.) be a parallelepiped, and A, a point in BK, the intersection of two of its sides, where a particle of matter is supposed to be placed; it is required to find the attraction in the direction AB.

THOUGH the placing of A in one of the intersections of the planes, seems to limit the inquiry, it has in reality no such effect; for wherever A be with respect to the parallelepiped, by drawing from it a perpendicular to the opposite plane of the solid, and making planes to pass through this perpendicular, the whole may be divided into four parallelepipeds, each having AB for an intersection of two of its planes; and being, therefore, related to the given particle, in the same way that the parallelepiped BF is to A.

LET GH be any section of the solid parallel to EC, and let it represent a plate of indefinitely small thickness.

LET AB' = x , B'b, the thickness of the plate = \dot{x} . Then ϕ being so determined, that $\sin \phi = \sin B'AH \times \sin B'AG$, the attraction of the plate GH is $\phi \dot{x}$, which, therefore, is the element

ment of the attraction of the solid. If that attraction = F, then $F = \int \phi \dot{x}$. But $\int \phi \dot{x} = \phi x - \int x \dot{\phi}$; and the determination of F depends, therefore, on the integration of $x \dot{\phi}$.

$$\text{Now } \dot{\phi} \operatorname{cof} \phi = \frac{\dot{\sin} \phi}{\operatorname{cof} \phi}, \text{ and, therefore, } x \dot{\phi} = \frac{x \dot{\sin} \phi}{\operatorname{cof} \phi}.$$

$$\text{IF } B'G = b, \text{ and } B'H = \beta, \text{ then } \sin B'AG = \frac{b}{AG} = \frac{b}{\sqrt{b^2 + x^2}},$$

$$\text{and } \sin B'AH = \frac{\beta}{AH} = \frac{\beta}{\sqrt{\beta^2 + x^2}}; \text{ so that } \sin \phi = \frac{b}{\sqrt{b^2 + x^2}} \times$$

$$\frac{\beta}{\sqrt{\beta^2 + x^2}}, \text{ and } \overline{\sin \phi}^2 = \frac{b^2 \beta^2}{(b^2 + x^2)(\beta^2 + x^2)}.$$

$$\text{HENCE, } \operatorname{cof} \phi^2 = 1 - \sin \phi^2 = 1 - \frac{b^2 \beta^2}{(b^2 + x^2)(\beta^2 + x^2)} =$$

$$\frac{x^2(b^2 + \beta^2 + x^2)}{(b^2 + x^2)(\beta^2 + x^2)}, \text{ and } \operatorname{cof} \phi = \frac{x \sqrt{b^2 + \beta^2 + x^2}}{\sqrt{(b^2 + x^2)(\beta^2 + x^2)}}.$$

$$\text{AGAIN, because } \sin \phi = \frac{b}{\sqrt{b^2 + x^2}} \cdot \frac{\beta}{\sqrt{\beta^2 + x^2}}, \overline{\sin \phi} = \frac{-b x \dot{x}}{(b^2 + x^2)^{\frac{3}{2}}}$$

$$\times \frac{\beta}{(\beta^2 + x^2)^{\frac{1}{2}}} - \frac{\beta x \dot{x}}{(\beta^2 + x^2)^{\frac{3}{2}}} \times \frac{b}{(b^2 + x^2)^{\frac{1}{2}}}.$$

$$\text{HENCE } \frac{\overline{\sin \phi}}{\operatorname{cof} \phi} \text{ or } \dot{\phi} =$$

$$\left(\frac{-b \beta x \dot{x}}{(b^2 + x^2)^{\frac{3}{2}} \times (\beta^2 + x^2)^{\frac{1}{2}}} - \frac{b \beta x \dot{x}}{(\beta^2 + x^2)^{\frac{3}{2}} \times (b^2 + x^2)^{\frac{1}{2}}} \right)$$

×

$$\times \frac{(b^2 + x^2)^{\frac{1}{2}} (\beta^2 + x^2)^{\frac{1}{2}}}{x \sqrt{b^2 + \beta^2 + x^2}} = \frac{b \beta \dot{x}}{(b^2 + x^2) (c^2 + x^2)^{\frac{1}{2}}}$$

$$\frac{b \beta \dot{x}}{(\beta^2 + x^2) (c^2 + x^2)^{\frac{1}{2}}}, \text{ } c^2 \text{ being put for } b^2 + \beta^2.$$

THEREFORE $x \dot{\phi} = \frac{b \beta x \dot{x}}{(b^2 + x^2) (c^2 + x^2)^{\frac{1}{2}}}$

$$\frac{b \beta x \dot{x}}{(\beta^2 + x^2) (c^2 + x^2)^{\frac{1}{2}}}.$$

Now, $\int \frac{-b \beta x \dot{x}}{(b^2 + x^2) (c^2 + x^2)^{\frac{1}{2}}} = b \text{ Log } \frac{\beta + \sqrt{c^2 + x^2}}{\sqrt{\beta^2 + x^2}} + C;$

(Harmonia Menfurarum, Form. ix.); and $\int \frac{-b \beta x \dot{x}}{(b^2 + x^2) (c^2 + x^2)^{\frac{1}{2}}} =$

$$\beta \text{ Log } \frac{b + \sqrt{c^2 + x^2}}{\sqrt{\beta^2 + x^2}} + C.$$

THEREFORE $\int x \dot{\phi} =$

$$b \text{ Log } \frac{\beta + \sqrt{c^2 + x^2}}{\sqrt{\beta^2 + x^2}} + \beta \text{ Log } \frac{b + \sqrt{c^2 + x^2}}{\sqrt{\beta^2 + x^2}} + C, \text{ and } \int \phi \dot{x} =$$

$$\phi x - b \text{ Log } \frac{\beta + \sqrt{c^2 + x^2}}{\sqrt{\beta^2 + x^2}} - \beta \text{ Log } \frac{b + \sqrt{c^2 + x^2}}{\sqrt{\beta^2 + x^2}} - C.$$

If, then, we determine C, so that the fluent may begin at K, and end at B; if, also, we make η the value of ϕ , that corresponds to AB or a ; and η' , the value of it that corresponds to

AK

AK or a' , we have the whole attraction of the solid, or $F =$

$$\eta a - \eta' a' - b \operatorname{Log} \frac{\beta + \sqrt{c^2 + a^2}}{\sqrt{b^2 + a^2}} \times \frac{\sqrt{b^2 + a'^2}}{\beta + \sqrt{c^2 + a^2}}$$

$$- \beta \operatorname{Log} \frac{b + \sqrt{c^2 + a^2}}{\sqrt{\beta^2 + a^2}} \times \frac{\sqrt{\beta^2 + a'^2}}{b + \sqrt{c^2 + a^2}}$$

IF, in this value of F , we invert the ratios, in order to make the logarithms affirmative, and write like quantities, one under the other, we have $F = \eta a - \eta' a'$

$$+ b \operatorname{Log} \frac{\beta + \sqrt{c^2 + a'^2}}{\beta + \sqrt{c^2 + a^2}} \times \frac{\sqrt{b^2 + a^2}}{\sqrt{b^2 + a'^2}}$$

$$+ \beta \operatorname{Log} \frac{b + \sqrt{c^2 + a'^2}}{b + \sqrt{c^2 + a^2}} \times \frac{\sqrt{\beta^2 + a^2}}{\sqrt{\beta^2 + a'^2}}$$

THE first two terms of this expression deserve particular attention, as η is an arch, such that $\sin \eta = \sin BAE \times \sin BAC$; therefore, by what has been before demonstrated, η is the measure of the angular space subtended at A by the rectangle BD . The first term in the value of F , therefore, is the product of the distance AB , into the angular space subtended by the rectangle BD . In like manner, the second term, or $\eta' a'$, is the product of the distance AK , into the angular space subtended by the rectangle KF .

THE relation of the quantities expressing the ratios, in the two logarithmic terms, will be best conceived by substituting for the algebraic quantities the lines that correspond to them in the diagram. Because $c^2 = b^2 + \beta^2 = EB^2 + BC^2$

$BC^2 = EC^2$, therefore $c = EC$ or BD . So also, $c^2 + a^2 = BD^2 + BA^2 = AD^2$, because ABD is a right angle, &c. Thus,

$$F = \eta a - \eta' a' + BE \cdot \text{Log} \frac{(AF + FN) AE}{(AD + DE) (AN)} +$$

$$BC \cdot \text{Log} \frac{(AF + FM) AC}{(AD + DC) AM}$$

THIS expression for the attraction of a parallelepiped, though considerably complex, is symmetrical in so remarkable a degree, that it will probably be found much more manageable, in investigation, than might at first be supposed. That it should be somewhat complex, was to be expected, as the want of continuity in the surface by which a solid is bounded, cannot but introduce a great variety of relations into the expression of its attractive force. The farther simplification, however, of this theorem, and the application of it to other problems, are subjects on which the limits of the present paper will not permit us to enter. The determinations of certain *maxima* depend on it, similar to those already investigated. It points at the method of finding the figure, which a fluid, whether elastic or unelastic, would assume, if it surrounded a cubical or prismatic body by which it was attracted. It gives some hopes of being able to determine generally the attraction of solids bounded by any planes whatever; so that it may, some time or other, be of use in the Theory of ChrySTALLIZATION, if, indeed, that theory shall ever be placed on its true basis, and founded, not on an hypothesis purely Geometrical, or in some measure arbitrary, but on the known Principles of Dynamicks.

PLATE VI.

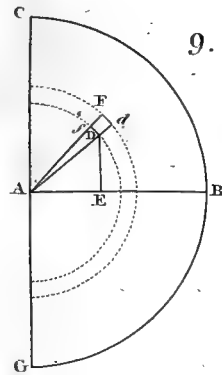
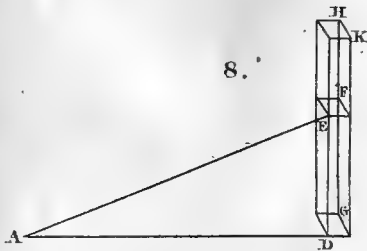
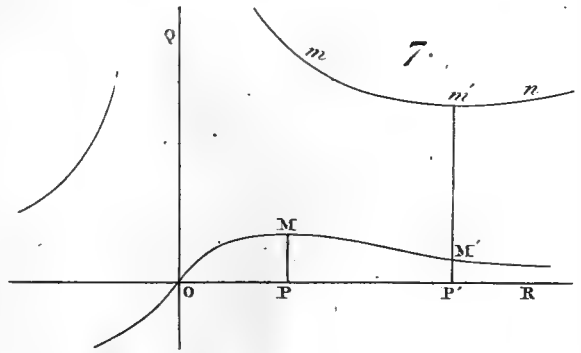
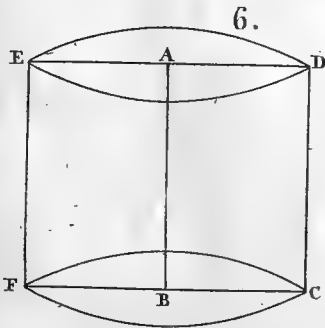
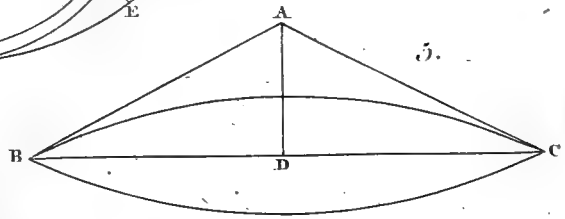
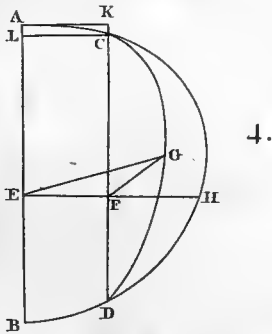
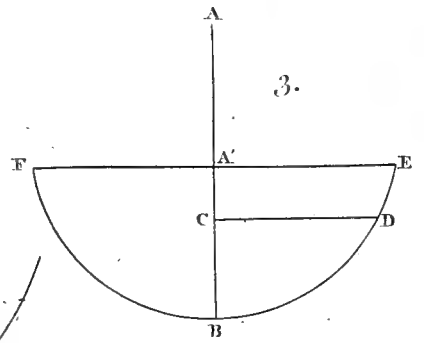
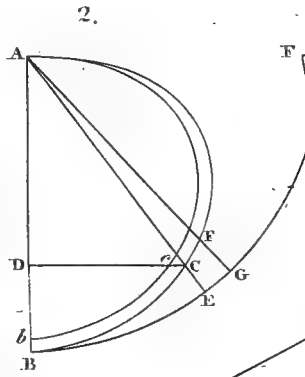
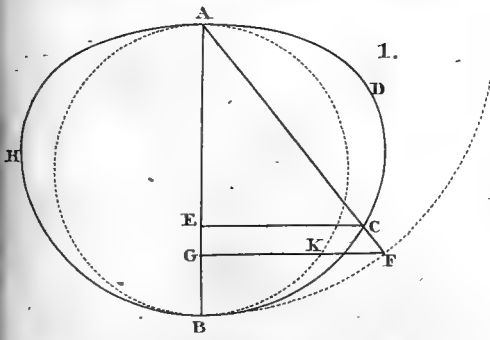
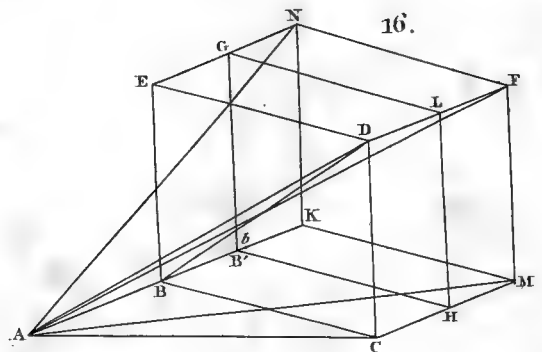
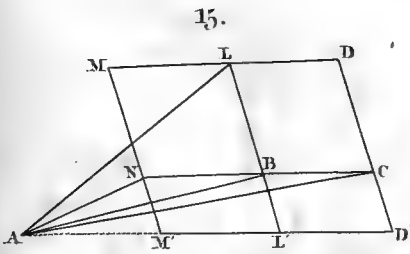
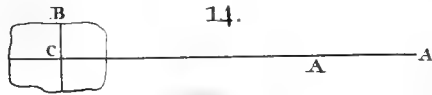
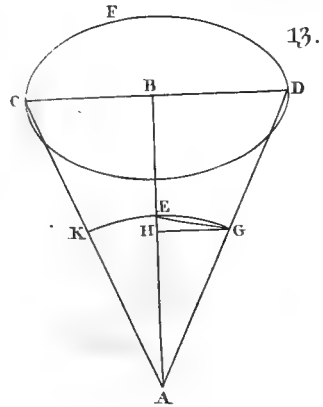
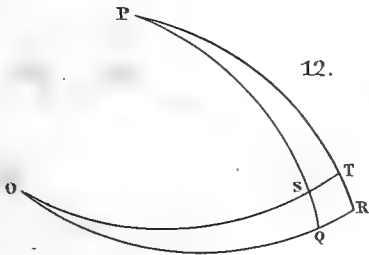
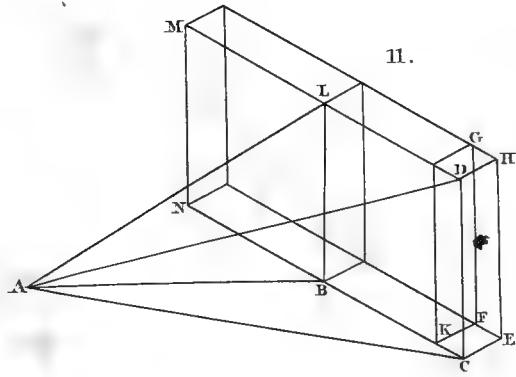
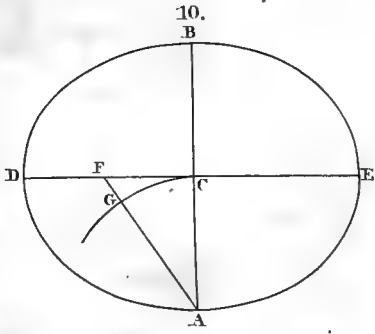
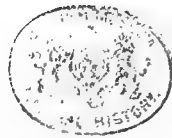



PLATE VII





V. *An Account of a very extraordinary Effect of REFRACTION, observed at Ramsgate, by the Reverend S. VINCE, A. M. F. R. S. Plumian Professor of Astronomy and Experimental Philosophy at Cambridge. Communicated by PATRICK WILSON, Esq; F. R. S. EDIN.*

[Read 5th January 1807.]

THE phenomenon about to be described, was seen on August 6. 1806, about seven in the evening; the air being very still, and a little hazy. The tops of the four turrets of Dover Castle usually appear above the hill, lying between Ramsgate and Dover; but, at the above-stated time, not only the tops were visible, but the whole of the Castle, appearing as if it were situated on the side of the hill next to Ramsgate, and rising as much above the hill as usual.

LET AB (Plate VIII. Fig. 1.) represent the termination of the hill; *v, x, w, y*, the tops of the four turrets of the Castle, as they usually appear. But, at the time above mentioned, besides thus seeing the turrets, the whole Castle *m n r s* was visible, and appeared as if it had been brought over and placed on the Ramsgate side of the hill, as represented in the figure. This phenomenon was so very singular and unexpected, that, at first sight, I thought it to be some illusion; but, upon continuing my obser-

H h 2

vation, I was satisfied that it was a real image of the Castle. Upon this I gave the telescope to a person present, who, upon attentive examination, saw also a very clear image of the Castle, exactly as I had described it. He continued to observe it for about twenty minutes, during which time the appearance remained precisely the same; but rain coming on, we were prevented from making any further observations. Between us and the land, from which the hill rises, there was about six miles of sea, and from thence to the top of the hill about the same distance, and we were about seventy feet above the surface of the water.

THE hill itself did not appear through the image, which, it might have been expected to do. The image of the Castle appeared very strong, and well defined; and although the rays from the hill behind it, must undoubtedly have come to the eye, yet so it was, that the strength of the image of the Castle so far obscured the back-ground, that it made no sensible impression upon us. Our attention was of course principally directed to the image of the Castle; but if the hill behind had been at all visible, it could not have escaped our observation, as we continued to look at it for a considerable time with a good telescope.

A PHENOMENON of this kind I do not remember to have seen described; and it must have been a very extraordinary state of the air to have produced it. It is manifest, that a ray of light coming from the top of the hill, must have come to the eye in a curve lying between the two curves described by the rays coming from the top and bottom of the Castle, in order to produce the effect.

LET AB (Plate VIII. Fig. 2.) represent the Castle, EC the Cliff (at Ramsgate), BTD the Hill, DC the Sea, E the place of the spectator, T the top of the hill, A γ v E a ray of light coming from the top of the Castle to the spectator,

B \times w E

$BxwE$ a ray coming from the bottom, and $TxzE$ a ray coming from the top of the hill, falling upon the eye at E , in a direction between those of the other two rays; then it is manifest, that such a disposition of the rays will produce the observed appearance. To effect this, there must have been a very quick variation of the density of the air which lay between the two curves yve , xwe , so as to increase the curvature of the ray $TxzE$, after it cuts Bwe in x , by which means, the ray $TxzE$, might fall between the other two rays. The phenomenon cannot be otherwise accounted for. As there are not, that I know of, any records of a phenomenon of this nature, the constitution of the air must have been such as but very rarely happens, or such an appearance would before have been taken notice of.

THE phenomena which I saw at the same place, and which I described in the Philosophical Transactions of the Royal Society for the year 1798, I explained upon the same principle, that of a quick variation of density; and this was afterwards confirmed by some very ingenious experiments made by Dr WOLLASTON. Perhaps this phenomenon may afterwards be subjected to an experimental illustration.

But if a ray coming from the bottom and T. R. a ray
 coming from the top of the hill, falling upon the eye
 in a direction between the two rays, then
 it is manifest, that such a disposition of the rays will produce
 the observed appearance. To effect this, there must have been
 a very quick variation of the density of the air which lay be-
 tween the two curves T. R. & T. R. so as to move the curve
 T. R. of the ray T. R. after it was in a position
 to meet the ray T. R. might fall between the other two rays.
 The phenomenon cannot be otherwise accounted for. As there
 is not that I know of any records of a phenomenon of this
 nature, the variation of the air must have been such as but
 very rarely happens, or that an appearance would before have
 been taken notice of.

The phenomenon which I saw at the same place, and which
 I described in the Philosophical Transactions of the Royal So-
 ciety for the year 1799, I explained upon the same principle,
 that of a quick variation of density; and this was afterwards
 confirmed by some very ingenious experiments made by Dr
 WARRASTON. Perhaps this phenomenon may afterwards be
 subjected to an experimental illustration.

Fig 1.

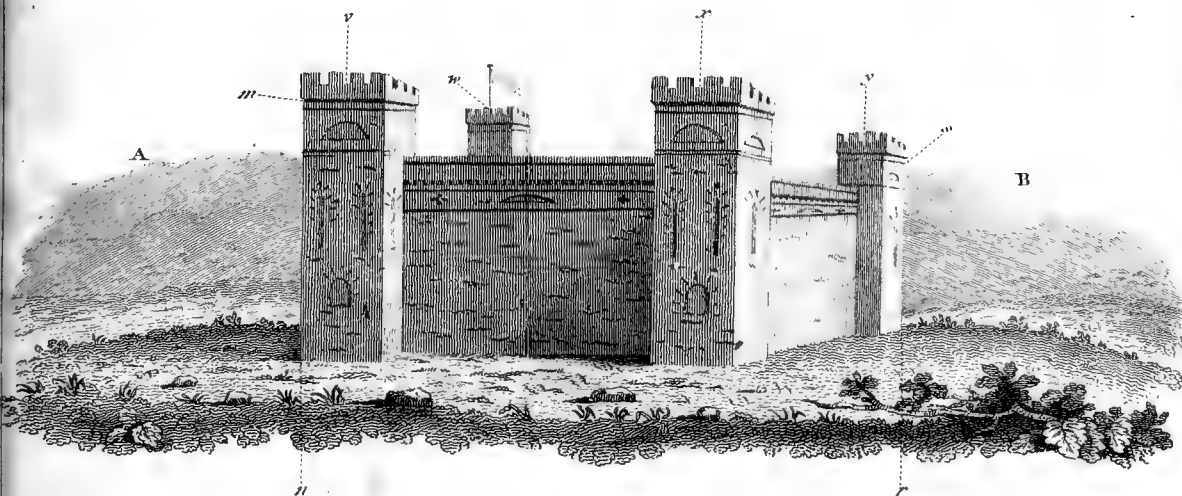
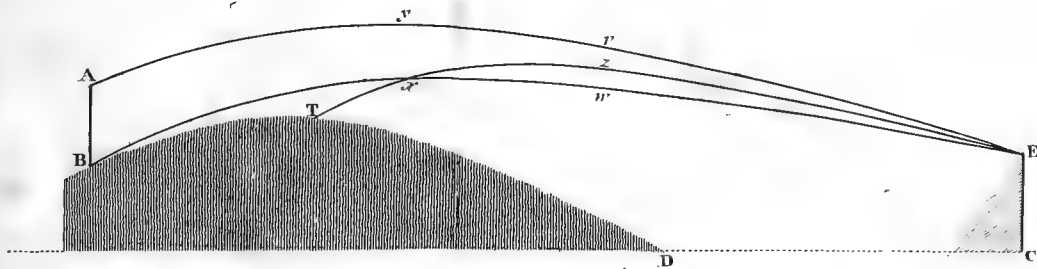

Fig. 2.





VI. *Some Account of the Large Snake ALEA-AZAGUR, (BOA CONSTRUCTOR of LINNÆUS), found in the Province of Tipperah. Communicated by MR JAMES RUSSELL. Extracted from the Memorandum Book of JOHN CORSE SCOTT, Esq.*

[Read 28th April 1807].

February 1, 1787.

A LARGE snake of this species was brought to Comillah. It measured 15 feet 3 inches in length, and 18 inches in circumference about the middle. This measurement, however, varied considerably by the wreathings and contortions it made, in order to free itself from confinement.

THE œsophagus, from the mouth to the pylorus, or bottom of the stomach, measured altogether 9 feet 3 inches, and was so wide as to take in a man's head with ease. The stomach was easily distinguished by the thickness of its coats, or the number of rugæ on its internal surface. But there was no contraction at the cardia or entrance of the stomach. The outlet or pylorus, however, was so narrow as hardly to admit two fingers.

THE head of the snake was small in proportion to its body. And I was curious to observe the mechanism of the jaw, by which it can so easily take into its mouth any substance as large as the thickest part of its body.

THE

THE lower jaw consists of two bones, connected anteriorly by skin and ligaments, which admit of considerable distension, so that the anterior ends can be separated an inch from each other. The posterior extremity, or condyle of each lower jaw-bone, is likewise connected to the head in such a manner, as to allow of considerable separation. The two bones which compose the upper jaw, are capable only of a very small degree of separation at the symphysis or anterior part.

THIS singular degree of laxity in the structure of the articulations, permits of a degree of distension which is incompatible with the firmness requisite to perform the function of mastication.

July 7. 1790.

A SNAKE of the allea species was brought in, of a very uncommon thickness in proportion to its length, which induced me to open it. A very large guana was extracted from the gullet and stomach; for the animal was gorged to the throat. The guana, from the nose to the tip of the tail, measured 4 feet 3 inches, and in circumference round the belly 1 foot 6 inches; and yet the snake, after the guana was taken out, measured only 8 feet 6 inches in length.

THE circumference of this snake is not given; but if it bore the same proportion to its length that it did in the former snake, it would be nearly 10 inches. In this instance, therefore, the snake had swallowed an animal of greater magnitude than itself almost in the proportion of 9 to 5.

ON the 16th of the same month another snake was brought in, having nearly the same appearance as the last, but still more distended. It was opened while yet alive, and an entire fawn of one year old extracted. The fawn measured 1 foot 8 inches round the belly; and the extreme length of the snake was only 9 feet 3 inches.

April

April 5. 1791.

A SNAKE of the same species was brought to Comillah and opened, from which a fawn was taken still larger than the one just mentioned; but the snake was 10 feet 6 inches in length.

It is the general opinion, that snakes break the bones of their prey before they swallow it, if the animal be of any considerable size. This, however, I am disposed to doubt, as in none of the above instances had the animal suffered such ossifraction, if I may be allowed the expression. The mechanism of the jaws, and the width of the gullet above described, render such violence unnecessary.

THE animal is swallowed very gradually, being first, I suspect, well lubricated with slime, with which this kind of large snake appears abundantly provided.

THESE circumstances may undoubtedly be deemed rather fabulous by those who have never seen nor examined large snakes. But they are facts not to be denied, and are well authenticated by every one who has had opportunities of seeing and opening such snakes.

DURING Mr LECKIE's residence at Comillah, I have learned from undoubted authority, that a snake of the above mentioned species was found dead, with the horns of a large deer sticking in his throat, supposed to be the cause of his death. The snake and the horns were both brought to Comillah in this situation; but in a putrid state. The snake measured above 17 feet in length; and the bones of it were afterwards sent to Mr CHARLES COLLINSON of Banleak.

VII. *Chemical Analysis of a BLACK SAND, from the River Dee in Aberdeenshire; and of a COPPER ORE, from Arthrey in Stirlingshire.* By THOMAS THOMSON, M. D. *Lecturer on Chemistry, Edinburgh.*

[Read 18th May 1807.]

THE specimen which formed the subject of the first of the following *analyses*, was brought from the banks of the river Dee, about seven years ago, by my friend Mr JAMES MILL, who at that time resided in Aberdeenshire. By him I was informed, that considerable quantities of it are found in different parts of the bed of that river,—that it is called by the inhabitants *iron-sand*,—and that they use it for sanding newly written paper. I tried some experiments in the year 1800, in order to ascertain its nature; but was too little skilled at that time, both in mineralogy and practical chemistry, to manage an analysis of any considerable difficulty.

THE black powder is mixed with a good many small whitish, reddish, and brownish grains, which, when examined by means of a glass, prove to be pieces of quartz, felspar, and mica. From this it would appear, that the sand of the river Dee consists chiefly of the detritus of granite or gneiss.

WHEN a magnet is passed over the sand, some of the black grains adhere to it, and are by this means easily obtained separate.

rate. But after all that can be attracted by the magnet is removed, the greater part of the black powder still remains. This residue is indeed attracted by a powerful magnet, but so very feebly, that it is not possible by means of it to separate it from the grains of sand with which it is mixed. Thus we learn, that the black matter consists of two distinct substances; one of which is powerfully attracted by the magnet, the other not. As this second substance was obviously specifically heavier than the grains of sand with which it was mixed, I placed a quantity of the powder on an inclined plane, and by exposing it cautiously, and repeatedly, to a jet of water, I succeeded in washing away most of the grains of sand, and thus obtained it in a state of tolerable purity.

THE first of these minerals we may call *iron-sand*, and the second *iserine*, as they belong to mineral species which oryctognosts have distinguished by these names.

I. IRON-SAND.

THE iron-sand is much smaller in quantity than the iserine, and does not exceed one-fourth of the mixture at most. Its colour is iron-black. It is in very small angular grains, commonly pretty sharp-edged, and sometimes having the shape of imperfect octahedrons. The surface is rough; the lustre is feebly glimmering and metallic; the fracture, from the smallness of the grains, could not be accurately ascertained, but it seemed to be conchoidal. Opaque, semihard, brittle, easily reduced to powder. Powder has a greyish-black colour; powerfully attracted by the magnet; specific gravity 4.765.

I. As acids were not found to act upon this mineral, 100 grains of it were reduced to a fine powder, mixed with twice
its

its weight of carbonate of potash, and exposed for two hours to a red heat, in a porcelain crucible. The mass, being softened in water, was digested in muriatic acid. By repeating this process twice, the whole was dissolved in muriatic acid, except a brownish-white matter, which being dried in the open air, weighed $19\frac{1}{2}$ grains.

2. THE muriatic acid solution, which had a deep yellowish-brown colour, was concentrated almost to dryness, and then diluted with water. It assumed a milky appearance; but nothing was precipitated. Being boiled for some time, and then set aside, a curdy-like matter fell. It was of a milk-white colour, weighed, when dry, 7 grains, and possessed the properties of oxide of titanium.

3. THE residual liquid being superfaturated with ammonia, a dark reddish-brown matter precipitated, which being separated by the filter, dried, drenched in oil, and heated to redness, assumed the appearance of a black matter, strongly attracted by the magnet. It weighed 93.7 grains, and was oxide of iron.

4. THE 19.5 grains of residual powder, being mixed with four times its weight of carbonate of soda, and exposed for two hours to a red heat, in a platinum crucible, and afterwards heated with muriatic acid, was all dissolved, except about a grain of blackish matter, which was set aside.

5. THE muriatic solution being concentrated by evaporation, a little white matter was separated. It weighed $\frac{1}{4}$ th of a grain; and possessed the characters of oxide of titanium.

6. WHEN

6. WHEN evaporated to dryness, and redissolved in water, a white powder remained, which proved to be filica, and which, after being heated to redness, weighed one grain.

7. THE watery solution being supersaturated with potash, and boiled for a few minutes, was thrown upon a filter, to separate a reddish-brown matter, which had been precipitated. The clear liquid which passed through the filter, was mixed with a solution of sal ammoniac. A soft white matter slowly subsided. It was alumina, and, after being heated to redness, weighed half a grain.

8. THE brown-coloured matter which had been precipitated by the potash, when dried upon the steam-bath, weighed 20.2 grains. It dissolved with effervescence in muriatic acid. The solution had the appearance of the yolk of an egg. When boiled for some time, and then diluted with water, it became white, and let fall a curdy precipitate, which weighed, when dry, 4.6 grains, and possessed the properties of oxide of titanium.

9. THE residual liquor being mixed with an excess of ammonia, let fall a brown matter, which, after being dried, drenched in oil, and heated to redness, weighed 6 grains. It was strongly attracted by the magnet, but was of too light a colour to be pure oxide of iron. I therefore dissolved it in muriatic acid, and placed it on the sand-bath, in a porcelain capsule. When very much concentrated by evaporation, small white needles began to make their appearance in it. The addition of hot-water made them disappear; but they were again formed when the liquor became sufficiently concentrated. These crystals, when separated, weighed 1.3 grains, and proved, on examination, to be white oxide of arsenic. During the solution
of

of the 6 grains in muriatic acid, a portion of black matter separated. It weighed 0.2 grains, and was totally dissipated before the blow-pipe in a white smoke. Hence, it must have been arsenic. These 1.5 gr. are equivalent to rather more than 1 grain of metallic arsenic. Thus, it appears, that the 6 grains contained 1 grain of arsenic, which explains the whiteness of their colour. The rest was iron. It can scarcely be doubted, that the proportion of arsenic present was originally greater. Some of it must have been driven off when the iron oxide was heated with oil.

10. THE insoluble residue, (No. 4.), was with great difficulty dissolved in sulphuric acid. When the solution was mixed with ammonia, a white powder fell, which weighed 0.8 grains. It was accidentally lost, before I examined its properties. But I have no doubt, from its appearance, that it was oxide of titanium.

11. THUS, from the 100 grains of iron-sand, the following constituents have been extracted by analysis :

Black oxide of iron,	-	98.70
White oxide of titanium,	-	12.65
Arsenic,	-	1.00
Silica and alumina,	-	1.50
		<hr/>
		Total, 113.85

Here there is an excess of nearly 14 grains, owing, without doubt, to the combination of oxygen with the iron and the titanium during the analysis.

HAD the iron in the ore been in the metallic state, the excess of weight, instead of 14, could not have been less than 30. For the black oxide is known to be a compound of 100 metal and

and 37 oxygen. Hence, I think, it follows, that the iron in our ore must have been in the state of an oxide, and that it must have contained less oxygen than black oxide of iron. A good many trials, both on iron-sand, and on some of the other magnetic ores of iron, induce me to conclude, that the iron in most of them is combined with between 17 and 18 *per cent.* of oxygen. This compound, hitherto almost overlooked by chemists, I consider as the real protoxide of iron. THENARD has lately demonstrated, the existence of an oxide intermediate between the black and the red; so that we are now acquainted with four oxides of this metal. But the protoxide, I presume, does not combine with acids like the others. Analogy leads us to presume the existence of a fifth oxide, between the green and the red.

As to the titanium, it is impossible to know what increase of weight it has sustained, because we are neither acquainted with it in the metallic state, nor know how much oxygen its different oxides contain. It is highly improbable, that, in iron-sand, the titanium is in the metallic state, if it be made out that the iron is in that of an oxide. The experiments of VAUQUELIN and HECHT, compared with those of KLAPROTH, have taught us that there are three oxides of titanium, namely, the blue, the red, and the white. From an experiment of VAUQUELIN and HECHT, and from some of my own, I am disposed to consider these oxides as composed of the following proportions of metal and oxygen:

	METAL.	OXYGEN.
1. Blue,	100	16
2. Red,	100	33
3. White,	100	49

I find, that when the white oxide of titanium is reduced to the state of red oxide, it loses one-fourth of its weight; and that
red

red oxide, when raised to the state of white oxide, increases exactly one-third of its weight. It was the knowledge of these facts, that led me to the preceding numbers. And I think they may be used, till some more direct experiment lead us to precise conclusions.

RED oxide being the only state in which this metal has yet occurred separate, we may conclude that it combines, in this state, with metallic oxides, and that the titanium in iron-sand, is most probably in this state. But white oxide, diminished by one-fourth, gives us the equivalent quantity of red oxide. On that supposition, the titanium present, before the analysis, in the 100 grains of ore, weighed 9.5 grains.

THE appearance of the arsenic surprised me a good deal, as it was altogether unexpected. I am disposed to ascribe it to some particles of arsenic pyrites which might have been accidentally present. This conjecture will appear the more probable, when we reflect, that arsenic pyrites very frequently accompanies iron-sand. Before the microscope, the iron-sand appears to contain some white shining particles, which, probably, are arsenic pyrites.

THE small quantity of silica and alumina, I ascribe, without hesitation, to grains of quartz and felspar, which had adhered to the iron-sand, and been analysed along with it. Some such grains were actually observed and separated. But others, probably, escaped detection.

12. IF these suppositions be admitted as well founded, the iron-sand was composed of

Protoxide of iron,	85.3
Red oxide of titanium,	9.5
Arsenic, - - -	1.0
Silica and alumina, -	1.5
Loss, - - -	2.7
	<hr/>
	100.0

The loss will not appear excessive, if we consider, that a portion of the arsenic must have been sublimed, before the presence of that metal was suspected.

UPON the whole, I think we may consider the specimen of iron-sand examined, as composed of 9 parts protoxide of iron, and 1 of red oxide of titanium. The presence of titanium in this ore had been already detected by LAMPADIUS, though, as I have not seen his analysis, I cannot say in what proportion.

II. ISERINE.

THE colour of this ore is iron-black, with a shade of brown. It consists of small angular grains, rather larger than those of the iron-sand, but very similar to them in their appearance. Their edges are blunt; they are smoother, and have a stronger glimmering lustre than those of the iron-sand. Lustre semi-metallic, inclining to metallic. The fracture could not be distinctly observed, but it seemed to be conchoidal; at least nothing resembling a foliated fracture could be perceived. Opaque, semihard, brittle, easily reduced to powder; colour of the powder unaltered; specific gravity 4.491*; scarcely attracted by the magnet.

I. A HUNDRED grains of the powdered ore were mixed with six times their weight of carbonate of soda, and exposed for two hours to a red heat, in a platinum crucible. The mass obtained being softened with water, dissolved completely in muriatic acid. When the solution was concentrated, it assumed the appearance

* Ir, as the following analysis would lead us to expect, the specimen examined was a mixture of four parts iserine, and one part quartz and felspar, the specific gravity of pure iserine should be 4.964.

pearance of the yolk of an egg. It was boiled, diluted with water, and set aside for some time. A white matter gradually deposited, which, when dried on the steam-bath, weighed 53 grains, and possessed the properties of oxide of titanium.

2. THE liquid thus freed from titanium, was evaporated to dryness, and the residue redissolved in water, acidulated with muriatic acid. A white powder remained, which, after being heated to redness, weighed 16.8 grains, and possessed the properties of filica.

3. THE solution was precipitated by ammonia, and the brown matter which had separated, boiled for some time in liquid potash. The whole was then thrown on a filter, to separate the undissolved part, and the liquid which came through, was mixed with a solution of sal ammoniac. A white powder fell, which, after being heated to redness, weighed 3.2 grains. It was alumina.

4. THE brown substance collected on the filter, was dried, drenched in oil, and heated to redness. It was strongly attracted by the magnet, and weighed 52 grains.

5. IT was digested in diluted sulphuric acid; but not being rapidly acted upon, a quantity of muriatic acid was added, and the digestion continued. The whole slowly dissolved, except a blackish matter, which became white when exposed to a red heat, and, as far as I could judge from its properties, was oxide of titanium, slightly contaminated with iron. It weighed 1.8 grains.

6. THE acid solution being concentrated by gentle evaporation, a number of small yellowish-coloured needles made their ap-

pearance in it. By repeated evaporations, all the crystals that would form were separated. They weighed 6 grains. I redissolved them in water, and added some ammonia to the solution. A fine yellow powder fell, which I soon recognized to be oxide of uranium. It weighed 4.2 grains.

7. Thus it appears, that the 52 grains (No. 4.), attracted by the magnet, contained 46 grains of iron, and 6 grains of uranium and titanium.

8. THE following are the substances separated from 100 grains of iserine, by the preceding analysis :

Oxide of titanium,	54.8
Oxide of iron, -	46.0
Oxide of uranium,	4.2
Silica, - -	16.8
Alumina, -	3.2

Total,	125.0

Here is an excess of no less than 25 grains, to be accounted for by oxygen, which must have united to the three metals during the process. As to the silica and alumina, there can be little hesitation in ascribing them to grains of sand, which had been mixed with the ore. The pure iserine, in all probability, was composed of iron, titanium, and uranium. If we suppose that each of these metals existed in the state of protoxide, we must diminish the titanium by one-fourth, the iron by one-seventh nearly, and the uranium, according to BUCHOLZ's experiments, by one-fifth. This would give us,

Titanium,

Titanium,	-	41.1
Iron,	-	39.4
Uranium,	-	3.4
Silica and alumina,		20.0
		103.9

Here, then, is still an excess of nearly 4 per cent. But this I am disposed to ascribe to the oxides of titanium and uranium, having been only dried upon the steam-bath. Upon the whole, it appears, that, in the specimens of iserine analysed, the proportions of titanium and iron were nearly equal, and that the uranium did not exceed 4 per cent. The appearance of uranium surprised me a good deal. I perceive, however, that it has already been detected in this ore, from an analysis published by Professor JAMESON, in the second volume of his Mineralogy, which, I understand, was made by LAMPADIUS. The specimen examined by LAMPADIUS yielded very nearly 60 parts of titanium, 30 of iron, and 10 of uranium. Whereas, in mine, if the foreign matter be removed, there was obtained, very nearly,

48	titanium,
48	iron,
4	uranium,
100	

But, there can be no doubt, that the iserine which I analysed was still contaminated with a good deal of iron-sand; for it was impossible to remove the whole.

Analysis of the GREY COPPER ORE, from Airthrey.

THE copper mine of Airthrey, near Stirling, consists of a thin vein, which runs through the west corner of the Ochils. It has been twice wrought, by two different companies. But, in both cases, was abandoned, after a few years trial. I went to it some years ago, and examined the ore, at the request of one of the proprietors. The specimens which were employed for the subsequent analysis, were the purest that I could select, out of a considerable quantity. I was told, however, that from the lower level, which was at that time full of water, much richer ore had been extracted. But, afterwards, when the lower level was freed from its water, I went down to it myself, and found the ore precisely of the same kind as in the upper, with this difference, that it was more mixed with calcareous spar, and perhaps, on that account, more easily smelted.

THE veinstones in the Airthrey mine are sulphate of barytes, and carbonate of lime, and with these the ore is almost always more or less mixed.

THE colour is at first light steel-grey; but the surface soon tarnishes, and becomes of a dark dull leaden-grey, and in some places assumes a beautiful tempered steel tarnish. Massive and disseminated. In some specimens, it exhibits the appearance of imperfect crystals. Internal surface shining and metallic; but, by exposure, it soon becomes dull. Fracture small-grained, inclining to even. Fragments indeterminate, and rather blunt-edged. Semihard, the degree being almost the same as that of calcareous spar; for these two minerals reciprocally scratch each

each other. Streak simular, opaque, brittle, easily frangible; specific gravity 4.878.

1. To free the ore as completely as possible from foreign matter, it was reduced to a coarse powder, and carefully picked. It was then digested in diluted muriatic acid, which dissolved a quantity of carbonate of lime, amounting to 13 *per cent.* of the original weight of the ore.

2. Thus purified, it was dried on the steam-bath, and 100 grains of it were reduced to a fine powder, and digested in diluted nitric acid, till every thing soluble in that menstruum was taken up. The residue was digested in the same manner, in muriatic acid; and when that acid ceased to act, the residue was treated with nitro-muriatic acid till no farther solution could be produced. The insoluble matter was of a white colour; it weighed 6.9 grains, and was almost entirely sulphate of barytes. No traces of sulphate of lead, nor of oxide of antimony, could be detected in it by the blow-pipe.

3. THE three acid solutions being mixed together, no cloudiness appeared, nor was any change produced; a proof that the ore contained no silver.

4. THE solution being evaporated nearly to dryness, was diluted with water, and precipitated by muriate of barytes. By this means, the sulphuric and arsenic acids, which had been formed during the long-continued action of the nitric acid on the ore, and the presence of which had been indicated by reagents, were thrown down; for nitrate of lead, added to the residual liquid, occasioned no precipitate; a proof that no arsenic acid was present.

5. THE

5. THE liquid, thus freed from arsenic acid, was mixed with an excess of ammonia. It assumed a deep blue colour, while a brown matter precipitated. It was separated by the filter, and being dried, drenched in oil, and heated to redness, it was totally attracted by the magnet. It weighed 45.5 grains, and was iron.

6. THE ammoniacal liquid was neutralised by sulphuric acid, and the copper thrown down by means of an iron plate. It weighed 17.2 grains.

7. To ascertain the quantity of sulphur and arsenic, 100 grains of the purified ore, in the state of a fine powder, were put into the bottom of a coated glass-tube, and exposed for two hours to a red heat. When the whole was cold, and the bottom of the tube cut off, the ore was found in a round solid mass, having the metallic lustre, a conchoidal fracture, and the colour and appearance of *variegated copper-ore*. It had lost 16 grains of its weight.

8. The upper part of the tube was coated with a yellowish-brown substance, like melted sulphur. It weighed 12.6 grains. Thus, there was a loss of 3.4 grains. As the tube was long, this loss can scarcely be ascribed to sulphur driven off. I rather consider it as water. For towards the beginning of the process, drops of water were very perceptible in the tube. Whether this water was a constituent of the ore, or derived from the previous digestion in muriatic acid, cannot be determined.

9. WHEN the 12.6 grains of yellowish brown matter detached from the tube, were digested in hot potash-ley, the whole was dissolved, except a fine blackish powder, which weighed

weighed 1 grain, and was arsenic. The dissolved portion I considered as sulphur.

10. THE potash solution, being mixed with nitric acid, 4 grains of sulphur fell. The remaining 7.6 grains must have been converted into sulphuric acid, by the action of the nitric acid. Accordingly, muriate of barytes occasioned a copious precipitate.

11. THE 84 grains of roasted ore being reduced to a fine powder, mixed with half their weight of pounded charcoal, and roasted a second time in a glass-tube, one grain of sulphur sublimed. But the tube breaking before the roasting had been continued long enough, the process was completed in a crucible. The roasted ore weighed 70 grains.

12. FROM the preceding analysis, we learn that the constituents of the Airthrey ore, are as follows :

Iron,	-	45.5
Copper,	-	17.2
Arsenic,	-	14.0
Sulphur,	-	12.6
Water,	-	3.4
Foreign bodies,		6.9
		99.6
Loss,	-	.4
		100.0

If we suppose the water and the earthy residue to be only accidentally present, then the only essential constituents are the first four, and the ore would be a compound of

Iron,	51.0
Copper,	19.2
Arsenic,	15.7
Sulphur,	14.1
	100.0

If we compare this analysis with several analyses of grey copper ore, lately published by KLAPROTH, we shall find, that the constituents are the same in both; but the proportions of the two first ingredients are very nearly reversed. KLAPROTH obtained from 0.4 to 0.5 of copper, and from 0.22 to 0.27 of iron. This renders it obvious, that the two ores were not in the same state. I have little doubt, that the difference, however, is merely apparent, and that it arose, altogether, from a quantity of iron pyrites, and perhaps also of arsenic pyrites, which I could not separate from the grey copper ore which I examined. Both of these minerals could be distinctly seen in many of the specimens, intimately mixed with the grey copper; and I have no doubt that the same mixture existed, even in those specimens which were selected as purest. The difference in the proportions of copper and arsenic, obtained by KLAPROTH * in his various analyses, is so considerable, as to lead to a suspicion, that even his specimens, in all probability, contained a mixture of foreign matter.

* GEHLEN'S Jour. vol. v. p. 9. 11. 13.

VIII. *New Series for the QUADRATURE of the CONIC SECTIONS, and the COMPUTATION of LOGARITHMS.*
By WILLIAM WALLACE, one of the Professors of Mathematics in the Royal Military College at Great Marlow, and F. R. S. EDIN.

[Read 27th June 1808.]

I. **T**HE Quadrature of the Conic Sections, and the Computation of Logarithms, are problems of considerable importance, not only in the elements of Mathematics, but also in the higher branches of that science. On this account, every successful attempt to simplify their resolution, as well as any new formulæ which may be found applicable to that purpose, must always be interesting, and must in some measure contribute to the improvement of mathematical knowledge.

2. THE object of this Paper, is to give solutions of these problems, which shall be at once simple and elementary, without employing the fluxional or other equivalent calculus; and it is presumed, that those which follow, will be found to partake so much of both these properties, that they may even admit of being incorporated with the elements of Geometry and Analysis. Besides, the formulæ which result from the investigations, are, as far as I know, entirely new, while each is appli-

cable to every possible case of the problem to be resolved. Now this last circumstance is the more remarkable, as it generally happens, that a series which applies very well to the quadrature of a curve within certain limits, is quite inapplicable beyond them.

3. ALTHOUGH, in a general way, this Paper may be said to treat of the quadrature of the Conic Sections, yet there is one of them, namely, the Parabola, which I shall not at all notice; because, although its area may be found in a way analogous to that which is here employed in the case of the other two, yet the formula which would thence result, must, from its nature, be the same as would be found by any other mode of proceeding.

As the quadratures of the ellipse, and any hyperbola may be deduced from those of the circle and equilateral hyperbola, I shall, in the following Paper, treat only of the two last; and as the quadrature of a sector of a circle, and the rectification of its bounding arch, are reducible the one to the other, it is a matter of indifference which of these we consider. I shall, however, confine myself to the latter.

4. IN treating of logarithms, I might, after the example of the earlier writers on this subject, deduce the formulæ for their computation from those which we shall find for the quadrature of the equilateral hyperbola. I prefer, however, treating this subject in a manner purely analytical, without adverting at all to the hyperbola, being of opinion, that every branch of mathematics ought, as much as possible, to be deduced from its own peculiar principles; and therefore, that it would be contrary to good method, to have recourse to the properties of geometrical figure, when treating of a subject entirely arithmetical.

5. To proceed now in the investigation of the different series, for the rectification of an arch of a circle, let A denote any arch, the radius being supposed unity. Then, from the arithmetic of sines, we have

$$\frac{1}{\tan A} = \frac{1}{2 \tan \frac{1}{2} A} - \frac{1}{2} \tan \frac{1}{2} A.$$

IN this formula let each term of the series of arches

$$a, \frac{1}{2} a, \frac{1}{4} a, \frac{1}{8} a \dots \dots \frac{1}{2^{n-2}} a, \frac{1}{2^{n-1}} a,$$

(which is a geometrical progression, having the number of its terms n , and its common ratio $\frac{1}{2}$;) be successively substituted for A, and let the results be multiplied by the terms of the corresponding series of fractions

$$1, \frac{1}{2}, \frac{1}{4}, \frac{1}{8} \dots \dots \frac{1}{2^{n-2}}, \frac{1}{2^{n-1}};$$

then we shall obtain the following series of equations:

$$\frac{1}{\tan a} = \frac{1}{2 \tan \frac{1}{2} a} - \frac{1}{2} \tan \frac{1}{2} a,$$

$$\frac{1}{2 \tan \frac{1}{2} a} = \frac{1}{4 \tan \frac{1}{4} a} - \frac{1}{4} \tan \frac{1}{4} a,$$

$$\frac{1}{4 \tan \frac{1}{4} a} = \frac{1}{8 \tan \frac{1}{8} a} - \frac{1}{8} \tan \frac{1}{8} a,$$

$$\frac{1}{8 \tan \frac{1}{8} a} = \frac{1}{16 \tan \frac{1}{16} a} - \frac{1}{16} \tan \frac{1}{16} a,$$

.....

$$\frac{1}{2^{n-2} \tan \frac{a}{2^{n-2}}} = \frac{1}{2^{n-1} \tan \frac{a}{2^{n-1}}} - \frac{1}{2^{n-1}} \tan \frac{a}{2^{n-1}}$$

$$\frac{1}{2^{n-1} \tan \frac{a}{2^{n-1}}} = \frac{1}{2^n \tan \frac{a}{2^n}} - \frac{1}{2^n} \tan \frac{a}{2^n}.$$

LET

LET the sums of the corresponding sides of these equations be taken, and observing that the series

$$\frac{1}{2 \tan \frac{1}{2} a} + \frac{1}{4 \tan \frac{1}{4} a} + \frac{1}{8 \tan \frac{1}{8} a} \dots + \frac{1}{2^{n-1} \tan \frac{a}{2^{n-1}}}$$

is found in each sum, let it be rejected from both; and the result will be

$$\frac{1}{\tan a} = \left\{ \begin{array}{l} \frac{1}{2^n \tan \frac{a}{2^n}} \\ - \left(\frac{1}{2} \tan \frac{1}{2} a + \frac{1}{4} \tan \frac{1}{4} a + \frac{1}{8} \tan \frac{1}{8} a + \frac{1}{16} \tan \frac{1}{16} a \dots \right. \\ \left. + \frac{1}{2^n} \tan \frac{a}{2^n} \right), \end{array} \right.$$

the number of terms of the series in the parenthesis being n , and hence we have

$$\frac{1}{2^n \tan \frac{a}{2^n}} = \frac{1}{\tan a} + \frac{1}{2} \tan \frac{1}{2} a + \frac{1}{4} \tan \frac{1}{4} a + \frac{1}{8} \tan \frac{1}{8} a +$$

$$\frac{1}{16} \tan \frac{1}{16} a \dots + \frac{1}{2^n} \tan \frac{a}{2^n}.$$

6. Now, $2 \tan \frac{1}{2} a$ is the perimeter of a figure formed by drawing tangents at the ends of the arch a , and producing them till they meet; and $4 \tan \frac{1}{4} a$ is the perimeter of a figure formed by bisecting the arch a , and drawing tangents at its extremities and at the point of bisection, producing each two adjoining tangents till they meet; and in general $2^n \tan \frac{a}{2^n}$ is the perimeter of a figure formed in the same way, by dividing the arch

arch a into 2^{n-1} equal parts, and drawing tangents at the points of division, and the extremities of the arch. Therefore, denoting the perimeter of the figure thus constructed by P , we have

$$\frac{P}{a} = \frac{1}{\tan a} + \frac{1}{2} \tan \frac{1}{2} a + \frac{1}{4} \tan \frac{1}{4} a + \frac{1}{8} \tan \frac{1}{8} a + \frac{1}{16} \tan \frac{1}{16} a \dots + \frac{1}{2^n} \tan \frac{a}{2^n};$$

and this is true, whatever be the number of terms in the series

$$\frac{1}{2} \tan \frac{1}{2} a + \frac{1}{4} \tan \frac{1}{4} a \dots + \frac{1}{2^n} \tan \frac{a}{2^n} *.$$

7. Now supposing n the number of terms in the series, to increase, then 2^{n-1} , the number of equal parts into which the arch is conceived to be divided, will also increase, and may become greater than any assignable number. But it is a principle admitted in the elements of geometry, that an arch being divided, and a polygon described about it in the manner specified in article 6., the perimeter of the polygon will continually approach to the circular arch, and will at last differ from it by less than any given quantity. Therefore, if we suppose n indefinitely great, so that the series may go on *ad infinitum*, then, instead of P in the formula of the last article, we may substitute its limit, namely, the arch a , and thus we shall have

$$\frac{a}{a} = \frac{1}{\tan a} + \frac{1}{2} \tan \frac{1}{2} a + \frac{1}{4} \tan \frac{1}{4} a + \frac{1}{8} \tan \frac{1}{8} a + \frac{1}{16} \tan \frac{1}{16} a + \dots$$

Thus

* We may here observe, that this formula may be considered as the analytic expression of a general theorem (which is not inelegant) relating to regular figures described about any arch of a circle; and others analogous to it will occur in the following investigations.

Thus we have the circular arch, or rather its reciprocal (from which the arch itself is easily found), expressed by a series of a very simple form; and this is the first formula which I proposed to give for the rectification of the circle.

8. WE now proceed to inquire what is the degree of convergency of this series. In the first place, it appears, that the numeral co-efficients of the terms are each one-half of that which goes before it. Again, A being any arch of a circle, we have by a theorem in the elements of geometry, $\sec A : 1 :: \tan A - \tan \frac{1}{2} A : \tan \frac{1}{2} A$; therefore, $1 + \sec A : 1 :: \tan A : \tan \frac{1}{2} A$,

and hence $\tan \frac{1}{2} A = \frac{\tan A}{1 + \sec A}$. But as $\sec A$ is greater than

1, therefore $1 + \sec A$ must be greater than 2, and consequent-

ly $\frac{\tan A}{1 + \sec A}$ less than $\frac{\tan A}{2}$; hence it follows, that $\tan \frac{1}{2} A$

must be less than $\frac{1}{2} \tan A$. Thus it appears, that a being any arch less than a quadrant, the tangent of any one of the series of arches $\frac{1}{2} a, \frac{1}{4} a, \frac{1}{8} a, \&c.$ is less than half the tangent of the arch before it. By combining the rate of convergency of the tangents with that of their numeral co-efficients, it appears, that each term of the series, after the second, is less than one-fourth of the term before it; and this is one limit to the rate of convergency of the series.

9. AGAIN, to find another limit, let us resume the formula $\tan \frac{1}{2} A = \frac{\tan A}{1 + \sec A}$, from which it follows, that $\frac{\tan \frac{1}{2} A}{\tan A}$

$= \frac{1}{1 + \sec A}$, and similarly, that $\frac{\tan \frac{1}{4} A}{\tan \frac{1}{2} A} = \frac{1}{1 + \sec \frac{1}{2} A}$. But

since

since $\sec \frac{1}{2} A < \sec A$, and consequently $\frac{1}{1 + \sec \frac{1}{2} A} > \frac{1}{1 + \sec A}$,

therefore $\frac{\tan \frac{1}{4} A}{\tan \frac{1}{2} A} > \frac{\tan \frac{1}{2} A}{\tan A}$, and $\tan \frac{1}{4} A > \frac{\tan \frac{1}{2} A}{\tan A} \times \tan \frac{1}{2} A$.

In this expression, let $\frac{1}{2} a, \frac{1}{4} a, \frac{1}{8} a$, &c. be substituted for A , and let the results be divided by 8, 16, 32, &c.; then we get

$$\frac{1}{8} \tan \frac{1}{8} a > \frac{\frac{1}{4} \tan \frac{1}{4} a}{\frac{1}{2} \tan \frac{1}{2} a} \times \frac{1}{4} \tan \frac{1}{4} a,$$

$$\frac{1}{16} \tan \frac{1}{16} a > \frac{\frac{1}{8} \tan \frac{1}{8} a}{\frac{1}{4} \tan \frac{1}{4} a} \times \frac{1}{8} \tan \frac{1}{8} a,$$

&c.

from which it appears, that in the series, $\frac{1}{a} = \frac{1}{\tan a} + \frac{1}{2} \tan \frac{1}{2} a$

$$+ \frac{1}{4} \tan \frac{1}{4} a + \frac{1}{8} \tan \frac{1}{8} a + \frac{1}{16} \tan \frac{1}{16} a +, \&c.$$

each term after the third (that is, after $\frac{1}{4} \tan \frac{1}{4} a$), is greater than a third proportional to the two terms immediately before it, taken in their order; and this is another limit to the rate of convergency of the series.

10. THE limits which we have found to the rate of convergency of the series, enable us also to assign limits to the sum of all the terms after any given term. Let the series be put under this form,

$$\frac{1}{a} = \frac{1}{\tan a} + \frac{1}{2} \tan \frac{1}{2} a + \frac{1}{4} \tan \frac{1}{4} a \dots + T_{(m)} + T_{(m+1)} + T_{(m+2)} +, \&c.$$

where $T_{(m)}$, $T_{(m+1)}$, $T_{(m+2)}$, &c. denote the terms whose places in the series are expressed by the numbers m , $m+1$, $m+2$, &c. Then, because

$$T_{(m+2)} < \frac{1}{4} T_{(m+1)},$$

$$T_{(m+3)} < \frac{1}{4} T_{(m+2)},$$

$$T_{(m+4)} < \frac{1}{4} T_{(m+3)},$$

&c.

We have

$$T_{(m+2)} + T_{(m+3)} + T_{(m+4)} + \dots, \text{ \&c.} < \frac{1}{4} \left(T_{(m+1)} \right. \\ \left. + T_{(m+2)} + T_{(m+3)} + \dots, \text{ \&c.} \right)$$

That is, putting S for $T_{(m+2)} + T_{(m+3)} + T_{(m+4)} + \dots, \text{ \&c.}$ or for the sum of all the terms after $T_{(m+1)}$,

$$S < \frac{1}{4} (T_{(m+1)} + S), \text{ and hence } \frac{3}{4} S < \frac{1}{4} T_{(m+1)}, \text{ \& } S < \frac{1}{3} T_{(m+1)}.$$

Thus it appears, that the sum of all the terms of the series following any term after the first, is less than the third part of that term.

II. AGAIN, from what has been said in Article 9., we have

$$T_{(m+2)} > \frac{T_{(m+1)}}{T_{(m)}} T_{(m+1)}, \text{ and therefore } \frac{T_{(m+2)}}{T_{(m+1)}} > \frac{T_{(m+1)}}{T_{(m)}},$$

$$\text{and similarly } \frac{T_{(m+3)}}{T_{(m+2)}} > \frac{T_{(m+2)}}{T_{(m+1)}}, \text{ and } \frac{T_{(m+4)}}{T_{(m+3)}} > \frac{T_{(m+3)}}{T_{(m+2)}}$$

and

and so on. From which it follows, that

$$T_{(m+2)} > \frac{T_{(m+1)}}{T_{(m)}} T_{(m+1)},$$

$$T_{(m+3)} > \frac{T_{(m+1)}}{T_{(m)}} T_{(m+2)},$$

$$T_{(m+4)} > \frac{T_{(m+1)}}{T_{(m)}} T_{(m+3)},$$

&c.

HENCE, taking the sum of the quantities on each side of the sign $>$, and putting S for

$$T_{(m+2)} + T_{(m+3)} + T_{(m+4)} +, \text{ \&c.}$$

we get

$$S > \frac{T_{(m+1)}}{T_{(m)}} (T_{(m+1)} + S).$$

Therefore $S - \frac{T_{(m+1)}}{T_{(m)}} S > \frac{T_{(m+1)}}{T_{(m)}}$, and consequently by reduction,

$$S > \frac{T_{(m+1)}}{T_{(m)} - T_{(m+1)}} T_{(m+1)};$$

from which it appears, that the sum of all the terms following any assigned term after the third, is greater than a third proportional to the difference of the two terms immediately before it and the latter of the two. But since this limit will not

differ much from the former, which is $\frac{1}{3} T_{(m+1)}$, it may be

more conveniently expressed thus;

$$S > \frac{1}{3} T_{(m+1)} - \frac{T_{(m)} - 4 T_{(m+1)}}{3 (T_{(m)} - T_{(m+1)})} T_{(m+1)};$$

which formula, by reduction, will be found to be the very same as the other.

12. THE result, then, of the whole investigation, may be briefly stated as follows: Let a denote any arch of a circle of which the radius is unity, then shall

$$\frac{1}{a} = \left\{ \begin{array}{l} \frac{1}{\tan a} + \frac{1}{2} \tan \frac{1}{2} a + \frac{1}{4} \tan \frac{1}{4} a + \frac{1}{8} \tan \frac{1}{8} a + \frac{1}{16} \tan \frac{1}{16} a \dots \\ + T_{(m)} + T_{(m+1)} + S; \end{array} \right.$$

where $T_{(m)}$ and $T_{(m+1)}$ denote any two succeeding terms of the series $\frac{1}{2} \tan \frac{1}{2} a + \frac{1}{4} \tan \frac{1}{4} a +$, &c., their places in it being expressed by the numbers m and $m+1$; and where S is put for the sum of all the remaining terms; and the limits of S are the two quantities

$$\frac{1}{3} T_{(m+1)} \text{ and } \frac{1}{3} T_{(m+1)} - \frac{(T_{(m)} - 4 T_{(m+1)}) T_{(m+1)}}{3 (T_{(m)} - T_{(m+1)})}, \text{ that}$$

is, S is less than the former, but greater than the latter.

The expressions $\tan \frac{1}{2} a$, $\tan \frac{1}{4} a$, $\tan \frac{1}{8} a$, &c. are easily deduced from $\tan a$, and from one another, by a well-known formula in the arithmetic of sines, which may be expressed thus,

$$\tan \frac{1}{2} A = \sqrt{\frac{1}{\tan^2 A} + 1} - \frac{1}{\tan A}.$$

13. I NOW proceed to the investigation of a second formula for the rectification of the circle; and for this purpose resume the

the equation $\frac{I}{\tan A} = \frac{I}{2 \tan \frac{1}{2} A} - \frac{I}{2} \tan \frac{1}{2} A$, which, by taking the square of each side, is transformed to

$$\frac{I}{\tan^2 A} = \frac{I}{4 \tan^2 \frac{1}{2} A} + \frac{I}{4} \tan^2 \frac{1}{2} A - \frac{I}{2}$$

In this formula, let each term of the series of arches

$$a, \frac{I}{2} a, \frac{I}{4} a, \frac{I}{8} a \dots \frac{a}{2^{n-1}},$$

of which the number of terms is n , be substituted successively for a , and let the results be multiplied by the corresponding terms of the series of fractions,

$$I, \frac{I}{4}, \frac{I}{4^2}, \frac{I}{4^3} \dots \frac{I}{4^{n-2}}, \frac{I}{4^{n-1}};$$

thus there will be formed the series of equations

$$\frac{I}{\tan^2 a} = \frac{I}{2^2 \tan^2 \frac{1}{2} a} + \frac{I}{4} \tan^2 \frac{1}{2} a - \frac{I}{2},$$

$$\frac{I}{2^2 \tan^2 \frac{1}{2} a} = \frac{I}{4^2 \tan^2 \frac{1}{4} a} + \frac{I}{4^2} \tan^2 \frac{1}{4} a - \frac{I}{2 \cdot 4},$$

$$\frac{I}{4^2 \tan^2 \frac{1}{4} a} = \frac{I}{8^2 \tan^2 \frac{1}{8} a} + \frac{I}{4^3} \tan^2 \frac{1}{8} a - \frac{I}{2 \cdot 4^2},$$

$$\frac{I}{8^2 \tan^2 \frac{1}{8} a} = \frac{I}{16^2 \tan^2 \frac{1}{16} a} + \frac{I}{4^4} \tan^2 \frac{1}{16} a - \frac{I}{2 \cdot 4^3},$$

.....

$$\frac{I}{2^{2n-4} \tan^2 \frac{a}{2^{n-2}}} = \frac{I}{2^{2n-2} \tan^2 \frac{a}{2^{n-1}}} + \frac{I}{4^{n-1}} \tan^2 \frac{a}{2^{n-1}} - \frac{I}{2 \cdot 4^{n-2}}$$

$$\frac{I}{2^{2n-2} \tan^2 \frac{a}{2^{n-1}}} = \frac{I}{2^{2n} \tan^2 \frac{a}{2^n}} + \frac{I}{4^n} \tan^2 \frac{a}{2^n} - \frac{I}{2 \cdot 4^{n-1}}$$

Let

Let the sum of these equations be taken, as in the investigation of the first formula, and observing that the series

$$\frac{1}{2^2 \tan^2 \frac{1}{2} a} + \frac{1}{4^2 \tan^2 \frac{1}{4} a} + \frac{1}{8^2 \tan^2 \frac{1}{8} a} \dots + \frac{1}{2^{2n-2} \tan^2 \frac{a}{2^{n-1}}}$$

is found on both sides of the resulting equation, let it be rejected from both; then we obtain

$$\tan^2 a = \left\{ \begin{array}{l} \frac{1}{2^{2n} \tan^2 \frac{a}{2^n}} \\ + \frac{1}{4} \tan^2 \frac{1}{2} a + \frac{1}{4^2} \tan^2 \frac{1}{4} a + \frac{1}{4^3} \tan^2 \frac{1}{8} a + \frac{1}{4^4} \tan^2 \frac{1}{16} a \dots \\ + \frac{1}{4^n} \tan^2 \frac{a}{2^n} - \left(\frac{1}{2} + \frac{1}{2 \cdot 4} + \frac{1}{2 \cdot 4^2} + \frac{1}{2 \cdot 4^3} \dots + \frac{1}{2 \cdot 4^{n-1}} \right). \end{array} \right.$$

Now it appears, that one part of this expression, viz.

$$\frac{1}{2} + \frac{1}{2 \cdot 4} + \frac{1}{2 \cdot 4^2} + \frac{1}{2 \cdot 4^3} \dots + \frac{1}{2 \cdot 4^{n-1}},$$

is a geometrical series, the first term of which is $\frac{1}{2}$, the last

term $\frac{1}{2 \cdot 4^{n-1}}$, and common ratio $\frac{1}{4}$; therefore its sum is

$$\frac{2}{3} \left(1 - \frac{1}{4^n} \right).$$

Also, since $2^n \tan \frac{a}{2^n}$ is the expression for the perimeter of a polygon, formed by dividing the arch a into 2^{n-1} equal parts, by drawing tangents at the points of division, and producing the

the adjacent tangents until they meet, (Art. 6.); therefore $2^{2n} \tan^2 \frac{a}{2^n}$ will be the square of that perimeter. Let the perimeter itself be denoted by P, then, substituting P^2 in the equation instead of $2^{2n} \tan^2 \frac{a}{2^n}$, and $\frac{2}{3} \left(1 - \frac{1}{4^n}\right)$ instead of the series to which it is equivalent, and bringing $\frac{1}{P^2}$ to one side, we get

$$\frac{1}{P^2} = \left\{ \begin{array}{l} \frac{1}{\tan^2 a} + \frac{2}{3} \left(1 - \frac{1}{4^n}\right) \\ - \left(\frac{1}{4} \tan^2 \frac{1}{2} a + \frac{1}{4^2} \tan^2 \frac{1}{4} a + \frac{1}{4^3} \tan^2 \frac{1}{8} a + \frac{1}{4^4} \tan^2 \frac{1}{16} a \dots \right. \\ \left. + \frac{1}{4^n} \tan^2 \frac{a}{2^n} \right). \end{array} \right.$$

15. THIS is true, whatever be the value of n , the number of terms of the series in the parenthesis. Let us now conceive the series to be continued indefinitely, then, as upon this hypothesis, n may be considered as indefinitely great, $\frac{1}{4^n}$ will become less than any assignable quantity, and therefore $\frac{2}{3} \left(1 - \frac{1}{4^n}\right)$ will become simply $\frac{2}{3}$; moreover, P will in this case become a , (Art. 7.), and P^2 will become a^2 . Thus, upon the whole, we shall

shall have

$$\frac{1}{a^2} = \left\{ \begin{array}{l} \frac{1}{\tan^2 a} + \frac{2}{3} \\ - \left(\frac{1}{4} \tan^2 \frac{1}{2} a + \frac{1}{4^2} \tan^2 \frac{1}{4} a + \frac{1}{4^3} \tan^2 \frac{1}{8} a + \frac{1}{4^4} \tan^2 \frac{1}{16} a \right. \\ \left. +, \&c. \right), \end{array} \right.$$

and this may be considered as a second formula for the rectification of any arch of a circle; for the process by which an arch is found from the square of its reciprocal is so simple, that the latter being known, the former may also be regarded as known.

16. INSTEAD of expressing the square of the reciprocal of the arch in this manner, by the squares of the tangents of its sub-multiples, we may express it otherwise by the squares of

their secants. For since $\tan^2 \frac{1}{2} a = \sec^2 \frac{1}{2} a - 1$, and $\tan^2 \frac{1}{4} a$

$= \sec^2 \frac{1}{4} a - 1$, and so on, therefore the series

$$\frac{1}{4} \tan^2 \frac{1}{2} a + \frac{1}{4^2} \tan^2 \frac{1}{4} a + \frac{1}{4^3} \tan^2 \frac{1}{8} a + \frac{1}{4^4} \tan^2 \frac{1}{16} a +, \&c.$$

is equivalent to

$$\frac{1}{4} \sec^2 \frac{1}{2} a + \frac{1}{4^2} \sec^2 \frac{1}{4} a + \frac{1}{4^3} \sec^2 \frac{1}{8} a + \frac{1}{4^4} \sec^2 \frac{1}{16} a +, \&c.$$

$$- \left(\frac{1}{4} + \frac{1}{4^2} + \frac{1}{4^3} + \frac{1}{4^4} +, \&c. \right),$$

But the latter part of this expression is evidently an infinite geometrical

geometrical series, of which the first term is $\frac{1}{4}$, and ratio $\frac{1}{4}$;

therefore its sum will be $\frac{1}{3}$; hence, by substitution, and putting

$\frac{1}{\sin^2 a}$ for $\frac{1}{\tan^2 a} + 1$, we have

$$\frac{1}{a^2} = \frac{1}{\sin^2 a} - \left(\frac{1}{4} \sec^2 \frac{1}{2} a + \frac{1}{4^2} \sec^2 \frac{1}{4} a + \frac{1}{4^3} \sec^2 \frac{1}{8} a + \frac{1}{4^4} \sec^2 \frac{1}{16} a +, \&c. \right),$$

which is the series to be investigated.

17. THERE is, however, another form, under which the series brought out in Article 15. may be given, and which I consider as the best adapted of any to the actual calculation of the length of an arch. This transformation will be effected,

if, in the well-known formula, $\tan^2 A = \frac{1 - \cos 2A}{1 + \cos 2A}$,

instead of A, we substitute successively $a, \frac{1}{2} a, \frac{1}{4} a, \&c.$; we

shall then obtain a series of fractions of the form $\frac{1 - \cos \frac{1}{n} a}{1 + \cos \frac{1}{n} a}$

which being substituted instead of their equivalents in the formula

$$\frac{1}{a^2} = \left\{ \begin{array}{l} \frac{1}{\tan^2 a} + \frac{2}{3} \\ - \left(\frac{1}{4} \tan^2 \frac{1}{2} a + \frac{1}{4^2} \tan^2 \frac{1}{4} a + \frac{1}{4^3} \tan^2 \frac{1}{8} a + \frac{1}{4^4} \tan^2 \frac{1}{16} a \right. \\ \left. +, \&c. \right), \end{array} \right.$$

it is changed to

$$\frac{1}{a^2} = \left\{ \begin{array}{l} \frac{1 + \operatorname{cof} 2a}{1 - \operatorname{cof} 2a} + \frac{2}{3} \\ - \left(\frac{1}{4} \frac{1 - \operatorname{cof} a}{1 + \operatorname{cof} a} + \frac{1}{4^3} \frac{1 - \operatorname{cof} \frac{1}{2} a}{1 + \operatorname{cof} \frac{1}{2} a} + \frac{1}{4^5} \frac{1 - \operatorname{cof} \frac{1}{4} a}{1 + \operatorname{cof} \frac{1}{4} a} \right. \\ \left. + \frac{1}{4^7} \frac{1 - \operatorname{cof} \frac{1}{8} a}{1 + \operatorname{cof} \frac{1}{8} a} +, \&c. \right); \end{array} \right.$$

or, putting $\frac{1}{2} a$ instead of a , and $\frac{1}{4} a$ instead of $\frac{1}{2} a$, and so on,

in order that the formula may contain only the cofines of the arch and its sub-multiples, and dividing the whole expression by 4,

$$\frac{1}{a^2} = \left\{ \begin{array}{l} \frac{1}{4} \frac{1 + \operatorname{cof} a}{1 - \operatorname{cof} a} + \frac{1}{6} \\ - \left(\frac{1}{4^3} \frac{1 - \operatorname{cof} \frac{1}{2} a}{1 + \operatorname{cof} \frac{1}{2} a} + \frac{1}{4^5} \frac{1 - \operatorname{cof} \frac{1}{4} a}{1 + \operatorname{cof} \frac{1}{4} a} + \frac{1}{4^7} \frac{1 - \operatorname{cof} \frac{1}{8} a}{1 + \operatorname{cof} \frac{1}{8} a} \right. \\ \left. + \frac{1}{4^9} \frac{1 - \operatorname{cof} \frac{1}{16} a}{1 + \operatorname{cof} \frac{1}{16} a} +, \&c. \right) \end{array} \right.$$

and this is the second series which I proposed to investigate, reduced to its most convenient form.

18. WE may determine two limits to the rate of convergency of the series just now found, in the same manner as we have found the limits of that of our first series; and, indeed, the reasoning employed in the one case is immediately applicable to the other. For if the first series, which is

$$\frac{1}{a} = \frac{1}{\tan a} + \frac{1}{2} \tan \frac{1}{2} a + \frac{1}{4} \tan \frac{1}{4} a + \frac{1}{8} \tan \frac{1}{8} a +, \&c.$$

be

be put under this form

$$\frac{1}{a} = \frac{1}{\tan a} + T_{(1)} + T_{(2)} + T_{(3)} + T_{(4)} +, \&c.$$

where $T_{(1)}$ is put for $\frac{1}{2} \tan \frac{1}{2} a$, and $T_{(2)}$ for $\frac{1}{4} \tan \frac{1}{4} a$, and $T_{(3)}$

for $\frac{1}{8} \tan \frac{1}{8} a$, &c., then, as the formula given at the conclusion

of the last article, becomes by substituting $\tan^2 \frac{1}{4} a$ for $\frac{1 - \operatorname{cof} \frac{1}{2} a}{1 + \operatorname{cof} \frac{1}{2} a}$,

and $\tan^2 \frac{1}{8} a$ for $\frac{1 - \operatorname{cof} \frac{1}{4} a}{1 + \operatorname{cof} \frac{1}{4} a}$, and so on,

$$\frac{1}{a^2} = \left\{ \begin{array}{l} \frac{1}{4} \frac{1 + \operatorname{cof} a}{1 - \operatorname{cof} a} + \frac{1}{6} \\ - \left(\frac{1}{4^2} \tan^2 \frac{1}{4} a + \frac{1}{4^3} \tan^2 \frac{1}{8} a + \frac{1}{4^4} \tan^2 \frac{1}{16} a +, \&c. \right) \end{array} \right.$$

it may be otherwise expressed thus,

$$\frac{1}{a^2} = \left\{ \begin{array}{l} \frac{1}{4} \frac{1 + \operatorname{cof} a}{1 - \operatorname{cof} a} + \frac{1}{6} \\ - (T^2_{(2)} + T^2_{(3)} + T^2_{(4)} + T^2_{(5)} +, \&c.), \end{array} \right.$$

where it is to be observed, that the symbols $T_{(2)}$, $T_{(3)}$, $T_{(4)}$, denote the very same quantities in both series.

Now, as we have found (Art. 8. and 9.), that each term of the series of quantities $T_{(2)}$, $T_{(3)}$, $T_{(4)}$, &c. is less than $\frac{1}{4}$ of the

term immediately before, but greater than a third proportional to the two terms immediately before it, taken in their order, it

manifest, that each term of the series in our second formula must be less than $\frac{1}{16}$ of the term before it, but greater than a third proportional to the two terms immediately preceding it; and these are the limits to the rates of convergency of our second series.

19. WE may also assign limits to the sum of all terms, after any proposed term: for putting it under this form

$$\frac{1}{a^i} = \left\{ \begin{array}{l} \frac{1}{4} \frac{1 + \cos a}{1 - \cos a} + \frac{1}{6} \\ - (T_{(1)} + T_{(2)} \dots + T_{(n)} + T_{(n+1)} + T_{(n+2)} +, \&c.), \end{array} \right.$$

where $T_{(1)}, T_{(2)}, \dots, T_{(n)}, \&c.$ now denote merely the terms of the series taken in their order, then because

$$T_{(m+2)} < \frac{1}{16} T_{(m+1)},$$

$$T_{(m+3)} < \frac{1}{16} T_{(m+2)},$$

$$T_{(m+4)} < \frac{1}{16} T_{(m+3)},$$

&c.

Therefore,

$$\begin{aligned} T_{(m+2)} + T_{(m+3)} + T_{(m+4)} +, \&c. < \frac{1}{16} (T_{(m+1)} \\ + T_{(m+2)} + T_{(m+3)} +, \&c.) \end{aligned}$$

That

That is, putting S for $T_{(m+2)} + T_{(m+3)} + T_{(m+4)} +$, &c.

$$S < \frac{1}{16} \{T_{(m+1)} + S\}, \text{ and hence } S < \frac{1}{15} T_{(m+1)}.$$

Thus it appears, that the sum of all the terms following any term, is less than $\frac{1}{15}$ of that term.

20. As to the other limit, it must be the same as the like limit of our first series, on account of their having the same limit to their corresponding rates of convergency. That is, putting S to denote as above, then

$$S > \frac{T_{(m+1)}}{T_{(m)} - T_{(m+1)}} T_{(m+1)};$$

$$\text{or } S > \frac{1}{15} T_{(m+1)} - \frac{T_{(m)} - 16 T_{(m+1)}}{15 (T_{(m)} - T_{(m+1)})} T_{(m+1)}.$$

21. It yet remains for us to consider how the series of quantities $\frac{1 - \operatorname{cof} a}{1 + \operatorname{cof} a}, \frac{1 - \operatorname{cof} \frac{1}{2} a}{1 + \operatorname{cof} \frac{1}{2} a},$ &c. are to be found. Now this may be done, either by computing the cofines of the series of arches $a, \frac{1}{2} a, \frac{1}{4} a, \frac{1}{8} a,$ &c. one from another by means of the formula $\operatorname{cof} \frac{1}{2} A = \sqrt{\frac{1 + \operatorname{cof} A}{2}}$, and thence computing the series of fractions $\frac{1 - \operatorname{cof} \frac{1}{2} a}{1 + \operatorname{cof} \frac{1}{2} a}, \frac{1 - \operatorname{cof} \frac{1}{4} a}{1 + \operatorname{cof} \frac{1}{4} a},$ &c. Or we may compute each fraction at once from that which precedes it, by a formula which may be thus investigated:

Put

Put $\frac{1 - \cos A}{1 + \cos A} = t$, and $\frac{1 - \cos \frac{1}{2} A}{1 + \cos \frac{1}{2} A} = t'$, then $\cos A = \frac{1 - t}{1 + t}$,

and $\frac{1 + \cos A}{2} = \frac{1}{1 + t}$; also $\cos \frac{1}{2} A = \frac{1 - t'}{1 + t'}$, now $\cos \frac{1}{2} A$

$= \sqrt{\frac{1 + \cos A}{2}}$, therefore $\frac{1 - t'}{1 + t'} = \frac{1}{\sqrt{1 + t}}$, and hence

$$t' = \frac{\sqrt{1 + t} - 1}{\sqrt{1 + t} + 1}.$$

22. UPON the whole, then, the result of the investigation of the second series may be stated briefly as follows. Let a denote any arch of a circle, its radius being unity, then

$$\frac{1}{a^2} = \left\{ \begin{array}{l} \frac{1}{4} \frac{1 + \cos a}{1 - \cos a} + \frac{1}{6} \\ - \left\{ \frac{1}{4^2} \frac{1 - \cos \frac{1}{2} a}{1 + \cos \frac{1}{2} a} + \frac{1}{4^3} \frac{1 - \cos \frac{1}{4} a}{1 + \cos \frac{1}{4} a} + \frac{1}{4^4} \frac{1 - \cos \frac{1}{8} a}{1 + \cos \frac{1}{8} a} \dots \&c. \right\} \\ + T_{(m)} + T_{(m+1)} + S \end{array} \right.$$

where $T_{(m)}$ and $T_{(m+1)}$ denote any two successive terms of the series in the parenthesis, and S denotes the sum of all the following terms; and here S will always be between the limits

$$\frac{1}{15} T_{(m)}, \text{ and } \frac{1}{15} T_{(m+1)} - \frac{(T_{(m)} - 16 T_{(m+1)}) T_{(m+1)}}{15 (T_{(m)} - T_{(m+1)})},$$

that is, it will be less than the former, but greater than the latter quantity.

THE series of cosines are to be deduced one from another by means of the formula

$$\cos \frac{1}{2} A = \sqrt{\frac{1 + \cos A}{2}}.$$

Or,

Or, compute the series of quantities $t, t', t'', t''', \&c.$, one from another by means of the formulæ

$$t = \frac{1 - \operatorname{cof} a}{1 + \operatorname{cof} a}, \quad t' = \frac{\sqrt{1+t} - 1}{\sqrt{1+t} + 1}, \quad t'' = \frac{\sqrt{1+t'} - 1}{\sqrt{1+t'} + 1}, \quad \&c.$$

Then will

$$\frac{1}{a^2} = \left\{ \begin{array}{l} \frac{1}{4} \frac{1 + \operatorname{cof} a}{1 - \operatorname{cof} a} + \frac{1}{6} \\ - \left(\frac{1}{4^2} t' + \frac{1}{4^3} t'' + \frac{1}{4^4} t''' + \frac{1}{4^5} t^{IV} \dots + T_{(m)} + T_{(m+1)} + S \right), \end{array} \right.$$

where $T_{(m)}, T_{(m+1)}$, and S denote the same as before.

I CONSIDER this second series for the rectification of the circle (under either of its forms), as preferable to the other series given at Article 12. for two reasons; first, because of its greater rate of convergency, and, next, because the quantities

$\operatorname{cof} a, \operatorname{cof} \frac{1}{2} a, \operatorname{cof} \frac{1}{4} a, \&c.$, also the quantities $t, t', t'', \&c.$ can

be deduced more easily one from another than the series of

tangents $\tan a, \tan \frac{1}{2} a, \tan \frac{1}{4} a, \tan \frac{1}{8} a, \&c.$

23. THAT we may investigate another series, let us

resume the formula $\frac{1}{\tan A} = \frac{1}{2 \tan \frac{1}{2} A} - \frac{1}{2} \tan \frac{1}{2} A$; the cubes

of both sides of the equation being now taken, the result is

$$\frac{1}{\tan^3 A} = \frac{1}{8 \tan^3 \frac{1}{2} A} - \frac{3}{8} \left\{ \frac{1}{\tan \frac{1}{2} A} - \tan \frac{1}{2} A \right\} - \frac{1}{8} \tan^3 \frac{1}{2} A.$$

To

To the sides of this equation let the corresponding sides of the equation

$$\frac{1}{\tan A} = \frac{1}{2} \left\{ \frac{1}{\tan \frac{1}{2} A} - \tan \frac{1}{2} A \right\}$$

be added; then we get

$$\frac{1}{\tan^3 A} + \frac{1}{\tan A} = \frac{1}{8} \left(\frac{1}{\tan^3 \frac{1}{2} A} + \frac{1}{\tan \frac{1}{2} A} \right) - \frac{1}{8} \left(\tan \frac{1}{2} A + \tan^3 \frac{1}{2} A \right).$$

Now $\frac{1}{\tan^3 A} + \frac{1}{\tan A} = \frac{1 + \tan^2 A}{\tan^3 A} = \frac{\sec^2 A}{\tan^3 A}$, and similarly,

$$\frac{1}{\tan^3 \frac{1}{2} A} + \frac{1}{\tan \frac{1}{2} A} = \frac{\sec^2 \frac{1}{2} A}{\tan^3 \frac{1}{2} A}, \text{ also } \tan \frac{1}{2} A + \tan^3 \frac{1}{2} A =$$

$$\tan \frac{1}{2} A (1 + \tan^2 \frac{1}{2} A) = \tan \frac{1}{2} A \sec^2 \frac{1}{2} A: \text{ therefore, by substituting, we get}$$

$$\frac{\sec^2 \frac{1}{2} A}{\tan^3 \frac{1}{2} A} = \frac{\sec^2 \frac{1}{2} A}{8 \tan^3 \frac{1}{2} A} - \frac{1}{8} \tan \frac{1}{2} A \sec^2 \frac{1}{2} A.$$

24. FROM this formula, by substituting $a, \frac{1}{2}a, \frac{1}{4}a \dots \frac{a}{2^{n-1}}$ for A , and multiplying the successive results by the fractions $1, \frac{1}{8}, \frac{1}{8^2} \dots \frac{1}{8^{n-1}}$, we deduce the following series of equations, the number of which is n :

$$\frac{\sec^2 a}{\tan^3 a}$$

$$\frac{\text{fec}^2 a}{\tan^3 a} = \frac{\text{fec}^2 \frac{1}{2} a}{2^3 \tan^3 \frac{1}{2} a} - \frac{1}{8} \tan \frac{1}{2} a \text{fec}^2 \frac{1}{2} a,$$

$$\frac{\text{fec}^2 \frac{1}{4} a}{2^3 \tan^3 \frac{1}{4} a} = \frac{\text{fec}^2 \frac{1}{8} a}{4^3 \tan^3 \frac{1}{8} a} - \frac{1}{8^2} \tan \frac{1}{4} a \text{fec}^2 \frac{1}{4} a,$$

$$\frac{\text{fec}^2 \frac{1}{8} a}{4^3 \tan^3 \frac{1}{8} a} = \frac{\text{fec}^2 \frac{1}{16} a}{8^3 \tan^3 \frac{1}{16} a} - \frac{1}{8^3} \tan \frac{1}{8} a \text{fec}^2 \frac{1}{8} a,$$

.....

$$\frac{\text{fec}^2 \frac{a}{2^{n-2}}}{2^{3(n-1)} \tan^3 \frac{a}{2^{n-2}}} = \frac{\text{fec}^2 \frac{a}{2^{n-1}}}{2^{3(n-1)} \tan^3 \frac{a}{2^{n-1}}} - \frac{1}{8^{n-1}} \tan \frac{a}{2^{n-1}} \text{fec}^2 \frac{a}{2^{n-1}},$$

$$\frac{\text{fec}^2 \frac{a}{2^{n-1}}}{2^{3(n-1)} \tan^3 \frac{a}{2^{n-1}}} = \frac{\text{fec}^2 \frac{a}{2^n}}{2^{3n} \tan^3 \frac{a}{2^n}} - \frac{1}{8^n} \tan \frac{a}{2^n} \text{fec}^2 \frac{a}{2^n}.$$

LET the sums of the corresponding sides of these equations be now taken, and rejecting from both the common series

$$\frac{\text{fec}^2 \frac{1}{2} a}{2^3 \tan^3 \frac{1}{2} a} + \frac{\text{fec}^2 \frac{1}{4} a}{2^3 \tan^3 \frac{1}{4} a} \dots + \frac{\text{fec}^2 \frac{a}{2^{n-1}}}{2^{3(n-1)} \tan^3 \frac{a}{2^{n-1}}},$$

the result will be

$$\frac{\text{fec}^2 a}{\tan^3 a} = \left\{ \frac{\text{fec}^2 \frac{a}{2^n}}{3^{3n} \tan^3 \frac{a}{2^n}} - \left[\frac{1}{8} \tan \frac{1}{2} a \text{fec}^2 \frac{1}{2} a + \frac{1}{8^2} \tan \frac{1}{4} a \text{fec}^2 \frac{1}{4} a \right. \right. \\ \left. \left. + \frac{1}{8^3} \tan \frac{1}{8} a \text{fec}^2 \frac{1}{8} a \dots + \frac{1}{8^n} \tan \frac{a}{2^n} \text{fec}^2 \frac{a}{2^n} \right] \right\}$$

and here the number of terms composing the series in the parenthesis is n .

LET us now conceive the series to go on *ad infinitum*, so that n may be considered as indefinitely great, then it is manifest, that $\sec^2 \frac{a}{2^n}$ will become equal to rad^2 ; now $2^n \tan \frac{a}{2^n}$ will become a , (Art. 6. and 7.) therefore $2^{3n} \tan^3 \frac{a}{2^n}$ will become a^3 ;

hence, substituting $\frac{1}{a^3}$ for $\frac{\sec^2 \frac{a}{2^n}}{2^{3n} \tan^3 \frac{a}{2^n}}$ in our equation, and trans-

posing, we get at last

$$\frac{1}{a^3} = \left\{ \begin{array}{l} \frac{\sec^2 a}{\tan^3 a} + \frac{1}{8} \tan \frac{1}{2} a \sec^2 \frac{1}{2} a + \frac{1}{8^2} \tan \frac{1}{4} a \sec^2 \frac{1}{4} a \\ + \frac{1}{8^3} \tan \frac{1}{8} a \sec^2 \frac{1}{8} a +, \&c. \end{array} \right.$$

and this is the third series which I proposed to investigate for the rectification of an arch of a circle.

25. THE series we have just now found, is evidently of a very simple form; it also converges pretty fast, each term being less than the 16th of that which precedes it. As, however, to apply it to actual calculation, it will be necessary to extract the cube root of a number, which is an operation of considerable labour when the root is to be found to several figures, perhaps, considered as a practical rule, this third formula is inferior to the two former. But if, on the other hand, we regard it merely as an elegant analytical theorem, it does not seem less deserving of notice than either of them.

26. THE

26. THE mode of reasoning by which we have found series expressing the three first powers of the reciprocal of an arch, will apply equally to any higher power, but the series will become more and more complex as we proceed, besides requiring in their application the extraction of high roots. In the case of the fourth power, however, the series is sufficiently simple, and converges faster than any we have yet investigated, while, at the same time, in its application we have only extractions of the square root. On these accounts, I shall here give its investigation.

RESUMING the expression $\frac{1}{\tan A} = \frac{1}{2 \tan \frac{1}{2} A} - \frac{1}{2} \tan \frac{1}{2} A$;

let the fourth power, and also the square of each side of the equation be taken, the result will be

$$\frac{1}{\tan^4 A} = \frac{1}{16 \tan^4 \frac{1}{2} A} - \frac{1}{4 \tan^2 \frac{1}{2} A} + \frac{3}{8} - \frac{1}{4} \tan^2 \frac{1}{2} A + \frac{1}{16} \tan^4 \frac{1}{2} A,$$

$$\frac{1}{\tan^2 A} = \frac{1}{4 \tan^2 \frac{1}{2} A} - \frac{1}{2} + \frac{1}{4} \tan^2 \frac{1}{2} A.$$

LET the first of these equations be multiplied by 4, and the second by 3, and let the results be added; then, reducing the fractions to a common denominator, we get

$$\frac{3+4 \tan^2 A}{\tan^4 A} = \frac{1}{16} \frac{3+4 \tan^2 \frac{1}{2} A}{\tan^4 \frac{1}{2} A} - \frac{14}{16} + \frac{1}{16} \left\{ 4 \tan^2 \frac{1}{2} A + 3 \tan^4 \frac{1}{2} A \right\}.$$

LET us, for the sake of brevity, express the complex quantity $\frac{3+4 \tan^2 A}{\tan^4 A}$ by the symbol $f A$, (which is not to be understood as the product of two quantities f and A , but as a character denoting a particular function of the arch A ;) and, similarly,

let $\frac{3+4 \tan^2 \frac{1}{2} A}{\tan^4 \frac{1}{2} A}$ be denoted by $f \frac{1}{2} A$, and so on. Also

let the other complex expression $4 \tan^2 \frac{1}{2} A + 3 \tan^4 \frac{1}{2} A$ be denoted by $F \frac{1}{2} A$; and if there were others like it, that is, which only differed by having $\frac{1}{4} A$, $\frac{1}{8} A$, &c. instead of $\frac{1}{2} A$, they would be denoted by $F \frac{1}{4} A$, $F \frac{1}{8} A$, &c.; then our last equation will stand thus,

$$f A = \frac{1}{16} f \frac{1}{2} A - \frac{14}{16} + \frac{1}{16} F \frac{1}{2} A,$$

and similarly, putting $\frac{1}{2} A$, $\frac{1}{4} A$, $\frac{1}{8} A$, &c. successively for A , and multiplying the results by the series of fractions $\frac{1}{16}$, $\frac{1}{16^2}$, $\frac{1}{16^3}$, &c.

$$\frac{1}{16} f \frac{1}{2} A = \frac{1}{16^2} f \frac{1}{4} A - \frac{14}{16^2} + \frac{1}{16^2} F \frac{1}{4} A,$$

$$\frac{1}{16^2} f \frac{1}{4} A = \frac{1}{16^3} f \frac{1}{8} A - \frac{14}{16^3} + \frac{1}{16^3} F \frac{1}{8} A,$$

&c.

By continuing this series of equations to n terms, and then taking their sum, and rejecting what is common to each side of the result, exactly as in the investigations of the three preceding formulæ, we shall get

$$f A = \frac{1}{2^{4n}} f \frac{A}{2^n} - 14 \left\{ \frac{1}{16} + \frac{1}{16^2} + \frac{1}{16^3} \dots + \frac{1}{16^n} \right\} \\ + \frac{1}{16} F \frac{1}{2} A + \frac{1}{16^2} F \frac{1}{4} A + \frac{1}{16^3} F \frac{1}{8} A \dots + \frac{1}{16^n} F \frac{A}{2^n}.$$

and this equation holds true, n being any whole positive number whatever.

27. LET us now, however, suppose n indefinitely great, then

the quantity $\frac{1}{2^{4n}} f \frac{A}{2^n}$, or $\frac{3 + 4 \tan^2 \frac{A}{2^n}}{\left(2^n \tan \frac{A}{2^n}\right)^4}$, becomes simply $\frac{3}{A^4}$, be-

cause $\tan \frac{A}{2^n}$, and consequently $4 \tan^2 \frac{A}{2^n}$, vanishes, and $2^n \tan \frac{A}{2^n}$ becomes A , as we have already had occasion to observe (Art. 6. and 7.). Also the geometrical series

$$\frac{1}{16} + \frac{1}{16^2} + \frac{1}{16^3} +, \&c.$$

having the number of its terms indefinitely great, and their common ratio $\frac{1}{16}$, will be $\frac{1}{15}$. Therefore, by substitution and transposition we have

$$\frac{3}{A^4} = fA + \frac{14}{15} - \left\{ \frac{1}{16} F_{\frac{1}{2}} A + \frac{1}{16^2} F_{\frac{1}{4}} A + \frac{1}{16^3} F_{\frac{1}{8}} A +, \&c. \right\}$$

or, substituting for fA , and $F_{\frac{1}{2}} A$, &c. the quantities which these symbols express,

$$\frac{3}{A^4} = \left\{ \begin{array}{l} \frac{3 + 4 \tan^2 \frac{A}{2^n}}{\tan^4 \frac{A}{2^n}} + \frac{14}{15} \\ - \left\{ \frac{1}{16} (4 \tan^2 \frac{1}{2} A + 3 \tan^4 \frac{1}{2} A) + \frac{1}{16^2} (4 \tan^2 \frac{1}{4} A + 3 \tan^4 \frac{1}{4} A) \right. \\ \left. + \frac{1}{16^3} (4 \tan^2 \frac{1}{8} A + 3 \tan^4 \frac{1}{8} A) +, \&c. \right\} \end{array} \right.$$

and this is one form of the series which we proposed to investigate.

28. THIS series, however, admits of being expressed under another form, better adapted to calculation, and to effect this transformation, let us begin with the term $\frac{3 + 4 \tan^2 A}{\tan^4 A}$. In

this quantity let $\frac{1 - \operatorname{cof} 2 A}{1 + \operatorname{cof} 2 A}$ be substituted for $\tan^2 A$; it then becomes, after proper reduction, $\frac{7 + 6 \operatorname{cof} 2 A - \operatorname{cof}^2 2 A}{1 - 2 \operatorname{cof} 2 A + \operatorname{cof}^2 2 A}$. A-

gain, in this expression let $\frac{1 + \operatorname{cof} 4 A}{2}$ be substituted for $\operatorname{cof}^2 2 A$, we then get

$$\frac{3 + 4 \tan^2 A}{\tan^4 A} = \frac{13 - \operatorname{cof} 4 A + 12 \operatorname{cof} 2 A}{3 + \operatorname{cof} 4 A - 4 \operatorname{cof} 2 A}$$

THE remaining terms of the series, which are similar to one another, and of the form $4 \tan^2 \frac{1}{2n} A + 3 \tan^4 \frac{1}{2n} A$, admit of a like transformation; for by substituting $\frac{1 - \operatorname{cof} \frac{1}{n} A}{1 + \operatorname{cof} \frac{1}{n} A}$ for

$\tan^2 \frac{1}{2n} A$, and again $\frac{1 + \operatorname{cof} \frac{2}{n} A}{2}$ for $\operatorname{cof}^2 \frac{1}{n} A$ in the result, we get

$$4 \tan^2 \frac{1}{2n} A + 3 \tan^4 \frac{1}{2n} A = \frac{13 - \operatorname{cof} \frac{2}{n} A - 12 \operatorname{cof} \frac{1}{n} A}{3 + \operatorname{cof} \frac{2}{n} A + 4 \operatorname{cof} \frac{1}{n} A}$$

By

By substituting these transformed expressions in the series, it becomes

$$\frac{3}{A^2} = \frac{13 - \operatorname{cof} 4A + 12 \operatorname{cof} 2A}{3 + \operatorname{cof} 4A - 4 \operatorname{cof} 2A} + \frac{14}{15}$$

$$- \left\{ \frac{1}{16} \frac{13 - \operatorname{cof} 2A - 12 \operatorname{cof} A}{3 + \operatorname{cof} 2A + 4 \operatorname{cof} A} + \frac{1}{16^2} \frac{13 - \operatorname{cof} A - 12 \operatorname{cof} \frac{1}{2}A}{3 + \operatorname{cof} A + 4 \operatorname{cof} \frac{1}{2}A} \right.$$

$$\left. + \frac{1}{16^3} \frac{13 - \operatorname{cof} \frac{1}{2}A - 12 \operatorname{cof} \frac{1}{4}A}{3 + \operatorname{cof} \frac{1}{2}A + 4 \operatorname{cof} \frac{1}{4}A} + \dots \right\}$$

FINALLY, let $\frac{1}{4}a$ be now substituted for A , and $\frac{1}{8}a$ for $\frac{1}{2}A$, and so on, and let the result be divided by 3×16 ; then we have

$$\frac{1}{a^2} = \frac{1}{3 \cdot 16^2} \frac{13 - \operatorname{cof} a + 12 \operatorname{cof} \frac{1}{2}a}{3 + \operatorname{cof} a - 4 \operatorname{cof} \frac{1}{2}a} + \frac{7}{8 \cdot 8 \cdot 9 \cdot 10}$$

$$- \left\{ \frac{1}{3 \cdot 16^3} \frac{13 - \operatorname{cof} \frac{1}{2}a - 12 \operatorname{cof} \frac{1}{4}a}{3 + \operatorname{cof} \frac{1}{2}a + 4 \operatorname{cof} \frac{1}{4}a} + \frac{1}{3 \cdot 16^4} \frac{13 - \operatorname{cof} \frac{1}{4}a - 12 \operatorname{cof} \frac{1}{8}a}{3 + \operatorname{cof} \frac{1}{4}a + 4 \operatorname{cof} \frac{1}{8}a} \right.$$

$$\left. + \frac{1}{3 \cdot 16^5} \frac{13 - \operatorname{cof} \frac{1}{8}a - 12 \operatorname{cof} \frac{1}{16}a}{3 + \operatorname{cof} \frac{1}{8}a + 4 \operatorname{cof} \frac{1}{16}a} + \dots \right\},$$

which is our fourth general series for the rectification of an arch; and its rate of convergence is very considerable, for each term is less than $\frac{1}{8^4}$ th of the term before it. The series, however, approaches continually to a geometrical progression, of which the common ratio is $\frac{1}{8^4}$.

29. THE preceding formulæ, as well as innumerable others, which may in like manner be deduced from the expression

$$\tan A = \frac{1}{2 \tan \frac{1}{2}A} - \frac{1}{2} \tan \frac{1}{2}A, \text{ all agree in expressing a power}$$

of the reciprocal of an arch by an infinite series, the terms of which

which are like functions of a series of arches, formed from the arch to be rectified, and from one another, by continual bisection. We may, however, in the very same way investigate the formulæ which shall express the reciprocal of the arch and its powers by like functions of arches deduced from one another by trisection, or any other section whatever. The most simple formula, which expresses an arch by functions deduced from it by trisection, may be investigated as follows:

$$30. \text{ FROM the known expression } \tan A = \frac{3 \tan \frac{1}{3} A - \tan^3 \frac{1}{3} A}{1 - 3 \tan^2 \frac{1}{3} A},$$

we readily get

$$\frac{1}{\tan A} = \frac{1}{3 \tan \frac{1}{3} A} - \frac{8}{3} \frac{\tan \frac{1}{3} A}{3 - \tan^2 \frac{1}{3} A},$$

and hence, by substituting $a, \frac{1}{3}a, \frac{1}{9}a, \&c.$ successively for A , and multiplying by the terms of the series $1, \frac{1}{3}, \frac{1}{9}, \&c.$ we derive the following equations,

$$\begin{aligned} \frac{1}{\tan a} &= \frac{1}{3 \tan \frac{1}{3} a} - \frac{8}{3} \frac{\tan \frac{1}{3} a}{3 - \tan^2 \frac{1}{3} a}, \\ \frac{1}{3 \tan \frac{1}{3} a} &= \frac{1}{9 \tan \frac{1}{9} a} - \frac{8}{3^2} \frac{\tan \frac{1}{9} a}{3 - \tan^2 \frac{1}{9} a}, \\ \frac{1}{9 \tan \frac{1}{9} a} &= \frac{1}{27 \tan \frac{1}{27} a} - \frac{8}{3^3} \frac{\tan \frac{1}{27} a}{3 - \tan^2 \frac{1}{27} a}, \\ &\&c. \end{aligned}$$

Now conceive this series of equations to be continued, till the number of equations be n , and their sum to be taken, and the quantities common to each side of the result rejected, as in the investigations of the other formulæ; then we shall have

$$\frac{1}{\tan a}$$

$$\frac{1}{\tan a} = \frac{1}{3^n \tan \frac{a}{3^n}} - \left\{ \frac{8}{3} \frac{\tan \frac{1}{3} a}{3 - \tan^2 \frac{1}{3} a} + \frac{8}{3^2} \frac{\tan \frac{1}{9} a}{3 - \tan^2 \frac{1}{9} a} \right. \\ \left. + \frac{8}{3^3} \frac{\tan \frac{1}{27} a}{3 - \tan^2 \frac{1}{27} a} \dots + \frac{8}{3^n} \frac{\tan \frac{a}{3^n}}{3 - \tan^2 \frac{a}{3^n}} \right\}.$$

And this is true, n being any number whatever. Now, if we consider that $3^n \tan \frac{a}{3^n}$ expresses the sum of the sines of a figure formed by dividing the arch into 3^n equal parts, and drawing tangents at the points of division, whose orders, reckoned from one end of the arch, are indicated by even numbers, (that end itself being reckoned one of them), and producing each to meet those adjoining to it, and the last to meet a radius of the circle produced through the other end of the arch, it will be obvious, that n being supposed to increase indefinitely, the expression $3^n \tan \frac{a}{3^n}$ will have for its limit the arch a , and in this case the

series will go on *ad infinitum*. Thus we shall have

$$\frac{1}{\tan a} = \frac{1}{a} - \left\{ \frac{8}{3} \frac{\tan \frac{1}{3} a}{3 - \tan^2 \frac{1}{3} a} + \frac{8}{3^2} \frac{\tan \frac{1}{9} a}{3 - \tan^2 \frac{1}{9} a} + \frac{8}{3^3} \frac{\tan \frac{1}{27} a}{3 - \tan^2 \frac{1}{27} a} +, \&c. \right\},$$

and by transposition,

$$\frac{1}{a} = \frac{1}{\tan a} + \frac{8}{3} \frac{\tan \frac{1}{3} a}{3 - \tan^2 \frac{1}{3} a} + \frac{8}{3^2} \frac{\tan \frac{1}{9} a}{3 - \tan^2 \frac{1}{9} a} + \frac{8}{3^3} \frac{\tan \frac{1}{27} a}{3 - \tan^2 \frac{1}{27} a} +, \&c.$$

and this is the series which I proposed to investigate.

31. THE series we have just now found, may be presented under various forms. Thus, by considering that

$$\frac{1}{\tan A} = \frac{\operatorname{cof} A}{\sin A} = \frac{2 \sin A \operatorname{cof} A}{2 \sin^2 A} = \frac{\sin 2 A}{1 - \operatorname{cof} 2 A},$$

and that

$$\frac{\tan A}{3 - \tan^2 A} = \frac{\frac{\sin A}{\operatorname{cof} A}}{3 - \frac{\sin^2 A}{\operatorname{cof}^2 A}} = \frac{1}{2} \frac{2 \sin A \operatorname{cof} A}{4 \operatorname{cof}^2 A - 1} = \frac{1}{2} \frac{\sin 2 A}{1 + 2 \operatorname{cof} 2 A}$$

it will appear that by due substitution the series may be otherwise expressed as follows :

$$\frac{1}{a} = \frac{1}{2} \frac{\sin a}{1 - \operatorname{cof} a} + \frac{2}{3} \frac{\sin \frac{1}{3} a}{1 + 2 \operatorname{cof} \frac{1}{3} a} + \frac{2}{3^2} \frac{\sin \frac{1}{9} a}{1 + 2 \operatorname{cof} \frac{1}{9} a} + \frac{2}{3^3} \frac{\sin \frac{1}{27} a}{1 + 2 \operatorname{cof} \frac{1}{27} a} + \&c.$$

And other forms might be given to it, but they would all converge with the same quickness, and each term would be less than $\frac{1}{3}$ th of the term before it. The series, however, under whatever form it be given, and all others which like it require for their application the trisection of an arch, are, when compared with those we formerly investigated, of little use as practical rules ; because it is well known that to determine the sine, or other such function of an arch from a function of its triple, is a problem which produces a cubic equation of a form which does not admit of being resolved otherwise than by trials, or by infinite series, both of which processes are sufficiently laborious, and only to be employed where the object in view cannot be attained by easier means.

32. As from the different series we have found for the rectification of an arch of a circle, the spirit of our method must be sufficiently obvious, I shall not investigate any others at present.

ferent. Before leaving this part of our subject, however, it may be proper to observe, that the second series may be deduced from the first, and the third from the second, and so on with respect to innumerable others of the same kind, by the fluxional or differential calculus.

FOR resumming the first series

$$\frac{1}{a} = \frac{1}{\tan a} + \frac{1}{2} \tan \frac{1}{2} a + \frac{1}{4} \tan \frac{1}{4} a + \frac{1}{8} \tan \frac{1}{8} a +, \&c.$$

if we take the fluxion of each term, considering a as a variable quantity, we have

$$\frac{-da}{a^2} = \frac{-da \sec^2 a}{\tan^2 a} + \frac{1}{4} da \sec^2 \frac{1}{2} a + \frac{1}{4^2} da \sec^2 \frac{1}{4} a + \frac{1}{4^3} da \sec^2 \frac{1}{8} a +, \&c.$$

and hence, changing the signs, and rejecting da from each term, and putting $1 + \tan^2 \frac{1}{n} a$ for $\sec^2 \frac{1}{n} a$, we find

$$\frac{1}{a^2} = \begin{cases} \frac{1}{\tan^2 a} + 1 - \left(\frac{1}{4} + \frac{1}{4^2} + \frac{1}{4^3} +, \&c. \right) \\ - \left(\frac{1}{4} \tan^2 \frac{1}{2} a + \frac{1}{4^2} \tan^2 \frac{1}{4} a + \frac{1}{4^3} \tan^2 \frac{1}{8} a +, \&c. \right) \end{cases}$$

In this expression, instead of the numeral series $\frac{1}{4} + \frac{1}{4^2} + \frac{1}{4^3} +, \&c.$

(which is a geometrical progression having its common ratio $\frac{1}{4}$)

substitute its value, viz. $\frac{1}{3}$, and the result is

$$\frac{1}{a^2} = \frac{1}{\tan^2 a} + \frac{2}{3} - \left\{ \frac{1}{4} \tan^2 \frac{1}{2} a + \frac{1}{4^2} \tan^2 \frac{1}{4} a + \frac{1}{4^3} \tan^2 \frac{1}{8} a +, \&c. \right\}$$

which is identical with the formula found at Art. 15.

FROM this series, by a like mode of proceeding, we may deduce our third series, and thence, again, our fourth, and so on: but this mode of investigation, although very simple, is certainly less elementary than that which we have followed. And it must be kept in mind, that one principal object of this paper is to employ only the first principles of geometry and analysis in treating of the subjects announced in its title.

33. BY a mode of deduction differing but little from that employed in the last article, we may even derive our first series from a known formula, the invention of which is attributed to EULER. It is this,

$$a = \sin a \sec \frac{1}{2} a \sec \frac{1}{4} a \sec \frac{1}{8} a +, \&c. *$$

FROM this expression, by the theory of logarithms, we get
 $\log a = \log \sin a + \log \sec \frac{1}{2} a + \log \sec \frac{1}{4} a + \log \sec \frac{1}{8} a +, \&c.$
 we have now only to take the fluxions of all the terms, and reject da , which is found in each, and the result is

$$\frac{1}{a} = \frac{1}{\tan a} + \frac{1}{2} \tan \frac{1}{2} a + \frac{1}{4} \tan \frac{1}{4} a + \frac{1}{8} \tan \frac{1}{8} a +, \&c.$$

which is the series in question.

34. I NOW proceed to the investigation of formulæ for the quadrature of the hyperbola, and as the principles from which they

* THIS formula, although very elegant as an analytical transformation, does not seem to admit of being applied with advantage to the rectification of an arch, on account of the great number of factors of the product which would be required to give a result tolerably correct.

they are to be deduced are in effect the same as we have had occasion to employ when treating of the circle, it will be proper to use the same form of reasoning, and the same mode of notation, in the one case as in the other.

THEREFORE, in the equilateral hyperbola ABB' , of which C is the centre, (Plate IX. Fig. 1.), and CA the semitransverse axis; let CB be drawn to any point B of the curve, and BD perpendicular to CA ; then, in imitation of the notation commonly used in the arithmetic of fines, which we have followed in the former part of this paper, we shall consider the co-ordinates CD , DB , as functions of the hyperbolic sector ACB , and putting S to denote its area, we shall denote the abscissa CD by $ab S$, and the ordinate BD by $ord S$.

DRAW AE touching the curve at its vertex, and meeting CB in E ; then, from similar triangles, we have $AE = \frac{DB}{CD} \times CA$;

therefore supposing the semitransverse axis AC to be unity, $AE = \frac{ord S}{ab S}$. Now this expression for the tangent correspond-

ing to a hyperbolic sector S , being analogous to $\frac{\sin A}{\cos A}$, the ex-

pression for the tangent of an angle A , we may similarly denote AE by the abbreviation $\tan S$. In like manner, if CB' be drawn to a point B' of the curve, bisecting the sector ACB , and meeting AE in E' , and $B'D'$ be drawn perpendicular to CA ;

then, as the sector ACB' will be $\frac{1}{2}S$, it follows, that

$$CD' = ab \frac{1}{2} S, B'D' = ord \frac{1}{2} S, \text{ and } AE' = \tan \frac{1}{2} S; \text{ and so on.}$$

35. FROM the nature of the hyperbola, we have

$$ab S = ab^2 \frac{1}{2} S + \text{ord}^2 \frac{1}{2} S, \quad \text{ord} S = 2 ab \frac{1}{2} S \text{ ord} \frac{1}{2} S;$$

therefore, by division,

$$\frac{ab S}{\text{ord} S} = \frac{ab \frac{1}{2} S}{2 \text{ord} \frac{1}{2} S} + \frac{1}{2} \frac{\text{ord} \frac{1}{2} S}{ab \frac{1}{2} S},$$

$$\text{that is, } \frac{1}{\tan S} = \frac{1}{2 \tan \frac{1}{2} S} + \frac{1}{2} \tan \frac{1}{2} S.$$

THIS last formula expresses a property of the hyperbola perfectly analogous to that of the circle (Art. 5.), from which we have deduced our first four series for the rectification of an arch. Therefore similarly, putting $s, \frac{1}{2}s, \frac{1}{4}s, \&c.$ successively

instead of S , and multiplying by the series of numbers $1, \frac{1}{2}, \frac{1}{4},$

&c. we have as in that article

$$\frac{1}{\tan s} = \frac{1}{2 \tan \frac{1}{2} s} + \frac{1}{2} \tan \frac{1}{2} s,$$

$$\frac{1}{2 \tan \frac{1}{2} s} = \frac{1}{4 \tan \frac{1}{4} s} + \frac{1}{4} \tan \frac{1}{4} s,$$

$$\frac{1}{4 \tan \frac{1}{4} s} = \frac{1}{8 \tan \frac{1}{8} s} + \frac{1}{8} \tan \frac{1}{8} s,$$

&c.

THIS series of equations being supposed continued until their number be n , by proceeding exactly as in Art. 5. when treating of the circle, we obtain

$$\frac{1}{2^n \tan \frac{s}{2^n}} =$$

$$\frac{1}{2^n \tan \frac{s}{2^n}} = \left\{ \begin{array}{l} \frac{1}{\tan s} - \left(\frac{1}{2} \tan \frac{1}{2} s + \frac{1}{4} \tan \frac{1}{4} s + \frac{1}{8} \tan \frac{1}{8} s + \frac{1}{16} \tan \frac{1}{16} s \dots \right. \\ \left. \dots + \frac{1}{2^n} \tan \frac{s}{2^n} \right). \end{array} \right.$$

36. LET us now suppose the hyperbolic sector ACB to be divided into 2^n equal parts, by lines drawn from the centre to the points 1, 2, 3, 4, . . . 7 in the curve, and tangents to be drawn at the extremities of the hyperbolic arch AB, and at the alternate intermediate points of division 2, 4, 6, &c. so as to form the polygon AFF'F''F'''BC. Then, by a known property of the hyperbola, the triangles ACF, FC2, 2CF', F'C4, . . . F'''CB are all equal, and as their number is 2^n , the whole polygon bounded by the tangents, and by the straight lines AC, CB will be equal to the triangle ACF taken 2^n times. But the area of

this triangle is $\frac{1}{2} AC \times AF = \frac{1}{2} \tan \frac{s}{2^n}$ (because $AF = \tan \frac{s}{2^n}$),

therefore $2^n \tan \frac{s}{2^n}$ expresses twice the area of the polygon

AFF'F''F'''BC. Let Q denote this area, then, substituting $\frac{1}{2} Q$

for $2^n \tan \frac{s}{2^n}$, and multiplying all the terms of the series by 2,

we have

$$\frac{1}{Q} = \left\{ \begin{array}{l} \frac{2}{\tan s} - \left(\tan \frac{1}{2} s + \frac{1}{2} \tan \frac{1}{4} s + \frac{1}{4} \tan \frac{1}{8} s + \frac{1}{8} \tan \frac{1}{16} s \dots \right. \\ \left. \dots + \frac{1}{2^n} \tan \frac{s}{2^n} \right). \end{array} \right.$$

Now

Now, the rectilinear space Q is evidently less than the hyperbolic sector s ; but n may be conceived so great that the difference between Q and s shall be less than any assignable space, as it is easy to demonstrate upon principles strictly geometrical; therefore, if we suppose n indefinitely great, then Q becomes s ; and as, upon this hypothesis, the series goes on *ad infinitum*, we have

$$\frac{I}{s} = \frac{2}{\tan s} - \left(\tan \frac{I}{2} s + \frac{I}{2} \tan \frac{I}{4} s + \frac{I}{4} \tan \frac{I}{8} s + \frac{I}{8} \tan \frac{I}{16} s +, \&c. \right)$$

which is our first series for the quadrature of an hyperbolic

sector. And as $\frac{I}{\tan S} = \frac{I}{2 \tan \frac{I}{2} S} + \frac{I}{2} \tan \frac{I}{2} S$, by resolving this

equation in respect of $\tan \frac{I}{2} S$, we get the formula

$$\tan \frac{I}{2} S = \frac{I}{\tan S} - \sqrt{\frac{I}{\tan^2 S} - I},$$

by which the series of quantities $\tan \frac{I}{2} s, \tan \frac{I}{4} s, \&c.$ may be

deduced from $\tan s = \frac{\text{ord } s}{ab s}$, and from one another.

37. THIS expression for an hyperbolic sector is perfectly similar in its form to that given in Art. 7. for an arch of a circle. It may, however, be transformed into another better adapted to calculation, by means of a property of the hyperbola to which there is no corresponding property of the circle, or at least none that can be expressed without employing the sign $\sqrt{-I}$. The property alluded to may be deduced from the
known

known formulæ

$$2 ab \frac{s}{n} = (ab s + \text{ord } s)^{\frac{1}{n}} + (ab s - \text{ord } s)^{\frac{1}{n}},$$

$$2 \text{ord } \frac{s}{n} = (ab s + \text{ord } s)^{\frac{1}{n}} - (ab s - \text{ord } s)^{\frac{1}{n}},$$

by proceeding as follows. Let each side of the latter of these equations be divided by the corresponding side of the former, the result is

$$\frac{\text{ord } \frac{s}{n}}{ab \frac{s}{n}} = \frac{(ab s + \text{ord } s)^{\frac{1}{n}} - (ab s - \text{ord } s)^{\frac{1}{n}}}{(ab s + \text{ord } s)^{\frac{1}{n}} + (ab s - \text{ord } s)^{\frac{1}{n}}},$$

which expression is equivalent to this other one,

$$\frac{\text{ord } \frac{s}{n}}{ab \frac{s}{n}} = \frac{\left(\frac{ab s + \text{ord } s}{ab s - \text{ord } s}\right)^{\frac{1}{n}} - 1}{\left(\frac{ab s + \text{ord } s}{ab s - \text{ord } s}\right)^{\frac{1}{n}} + 1}$$

LET us now put p for the fraction $\frac{ab s + \text{ord } s}{ab s - \text{ord } s}$, then, re-

marking that $\frac{\text{ord } \frac{s}{n}}{ab \frac{s}{n}} = \tan \frac{s}{n}$, we have

$$\tan \frac{s}{n} = \frac{p^{\frac{1}{n}} - 1}{p^{\frac{1}{n}} + 1}$$

an equation which expresses the property we proposed to investigate.

38. WE have now only to suppose n in this formula to have these values, 2, 4, 8, &c. successively, and to substitute instead of the terms of our series

$$\frac{1}{s} = \frac{2}{\tan s} - \left(\tan \frac{1}{2} s + \frac{1}{2} \tan \frac{1}{4} s + \frac{1}{4} \tan \frac{1}{8} s +, \&c. \right),$$

their values as given by the formula, putting also $\frac{\text{ord } s}{ab s}$ instead of $\tan s$, and the series becomes

$$\frac{1}{s} = \frac{2 ab s}{\text{ord } s} - \left\{ \frac{\rho^{\frac{1}{2}} - 1}{\rho^{\frac{1}{2}} + 1} + \frac{1}{2} \frac{\rho^{\frac{1}{4}} - 1}{\rho^{\frac{1}{4}} + 1} + \frac{1}{4} \frac{\rho^{\frac{1}{8}} - 1}{\rho^{\frac{1}{8}} + 1} +, \&c. \right\}$$

and this is the new form under which we proposed to exhibit it.

39. LET us now inquire what are the limits of the rate of convergency of this series; and in doing this, it will be most convenient to refer to the first of its two forms. Now, from the formula $\frac{1 - \tan^2 \frac{1}{2} S}{\tan S} = \frac{1}{2 \tan \frac{1}{2} S} - \frac{1}{2} \tan \frac{1}{2} S$, we get

$$\tan \frac{1}{2} S = \frac{1}{2} \tan S (1 + \tan^2 \frac{1}{2} S). \text{ But } 1 + \tan^2 \frac{1}{2} S > 1, \text{ and}$$

therefore $\frac{1}{2} \tan S (1 + \tan^2 \frac{1}{2} S) > \frac{1}{2} \tan S$, hence it follows, that

$$\tan \frac{1}{2} S > \frac{1}{2} \tan S. \text{ Thus it appears, that each term of the series}$$

ries

ries of quantities $\tan \frac{1}{4} s$, $\tan \frac{1}{8} s$, &c. is greater than half the term before it; and as these, multiplied by the fractions $\frac{1}{2}$, $\frac{1}{4}$, &c. respectively constitute the terms of the series, each term of the series, under either of its forms, is greater than one-fourth of the term before it.

40. AGAIN, from the formula $\tan \frac{1}{2} S = \frac{1}{2} \tan S (1 + \tan^2 \frac{1}{2} S)$ we find $\frac{2 \tan \frac{1}{2} S}{\tan S} = 1 + \tan^2 \frac{1}{2} S$, and similarly, $\frac{2 \tan \frac{1}{4} S}{\tan \frac{1}{2} S} = 1 + \tan^2 \frac{1}{4} S$. But from the nature of the hyperbola $1 + \tan^2 \frac{1}{4} S < 1 + \tan^2 \frac{1}{2} S$; therefore $\frac{2 \tan \frac{1}{4} S}{\tan \frac{1}{2} S} < \frac{2 \tan \frac{1}{2} S}{\tan S}$, and hence $\tan \frac{1}{4} S < \frac{\tan^2 \frac{1}{2} S}{\tan S}$. Therefore, putting $\frac{1}{2n} s$ instead of S , and multiplying by $\frac{1}{4n}$, we have

$$\frac{1}{4n} \tan \frac{1}{8n} s < \frac{\frac{1}{2n} \tan \frac{1}{4n} s}{\frac{1}{n} \tan \frac{1}{2n} s} \times \frac{1}{2n} \tan \frac{1}{4n} s,$$

from which it appears, that each term of the series, following the second, is less than a third proportional to the two terms immediately before it. So that, upon the whole, it appears, that the limits of the rate of convergency of our first series for an hyperbolic sector, are the same as those of our first for an arch

Qq 2 of

of a circle, (see Art. 8. and 9.), only the greater limit in the one case corresponds to the lesser limit in the other, and *vice versa*.

41. WE might now, from these limits to the rate of convergence, determine two limits to the sum of all the terms of the series following any given term, by the mode of investigation employed at Art. 10. and Art. 11. in the case of the circle; but the result in both cases would be found to be the same, with the difference of the sign $<$ for $>$, and $>$ for $<$; that is, we would find the sum of all the terms following any term of the series, to be greater than one-third of that term, but less than a third proportional to the difference between the two terms immediately before it and the latter of the two.

42. UPON the whole, then, our first formula, for the quadrature of an hyperbolic sector, may be expressed as follows.

LET s denote the area of the sector, and put p for $\frac{ab s + \text{ord } s}{ab s - \text{ord } s}$.

Then,

$$\frac{1}{s} = \frac{2 ab s}{\text{ord } s} - \left\{ \frac{p^{\frac{1}{2}} - 1}{p^{\frac{1}{2}} + 1} + \frac{1}{2} \frac{p^{\frac{1}{4}} - 1}{p^{\frac{1}{4}} + 1} + \frac{1}{4} \frac{p^{\frac{1}{8}} - 1}{p^{\frac{1}{8}} + 1} + \frac{1}{8} \frac{p^{\frac{1}{16}} - 1}{p^{\frac{1}{16}} + 1} \dots \right. \\ \left. + T_{(m)} + T_{(m+1)} + R \right\}$$

where $T_{(m)}$ and $T_{(m+1)}$ denote any two succeeding terms of the series, and R the sum of all the following terms*. And here

* THE same series may also be put under another form, which it may not be improper to notice briefly, on account of the facility with which the terms may be

here

$$R > \frac{1}{3} T_{(m+1)}$$

$$\text{but } R < \frac{T_{(m+1)}}{T_{(m)} - T_{(m+1)}} \times T_{(m+1)}.$$

As these limits to R differ but little when the terms $T_{(m)}$, $T_{(m+1)}$ are considerably advanced in the series, the latter may be expressed more conveniently for calculation thus

$$R < \frac{1}{3} T_{(m+1)} + \frac{(4 T_{(m+1)} - T_{(m)}) T_{(m+1)}}{3 (T_{(m)} - T_{(m+1)})}$$

43. LET us next investigate a series for the quadrature of the hyperbola, which may be analogous to our second series for the rectification of the circle. For this purpose, proceeding as at

Art. 13. we resume the formula $\frac{1}{\tan S} = \frac{1}{2 \tan \frac{1}{2} S} + \frac{1}{2} \tan \frac{1}{2} S$,

and taking the square of each side of the equation, get

$$\frac{1}{\tan^2 S} = \frac{1}{4 \tan^2 \frac{1}{2} S} + \frac{1}{4} \tan^2 \frac{1}{2} S + \frac{1}{2}$$

Instead

be deduced one from another by the help of the common trigonometrical tables. It is this,

$$\frac{1}{s} = \frac{2 ab s}{\text{ord } s} - (\sin a' + \frac{1}{2} \sin a'' + \frac{1}{4} \sin a''' + \frac{1}{8} \sin a^{iv} \dots + T_{(m)} + T_{(m+1)} + R).$$

The arches a' , a'' , a''' , a^{iv} , &c. are to be deduced one from another as follows.

Take α such that $\sin \alpha = \frac{\text{ord } s}{ab s}$, then, $\sin a' = \tan \frac{1}{2} \alpha$, $\sin a'' = \tan \frac{1}{2} a' \sin a''' =$

$\tan \frac{1}{2} a''$, $\sin a^{iv} = \tan \frac{1}{2} a'''$, &c. The symbols $T_{(m)}$, $T_{(m+1)}$ and R, denote

the same things as in the other form of the series.

Instead of S , we now substitute in this expression $s, \frac{1}{2}s, \frac{1}{4}s, \frac{1}{8}s,$
 &c. successively, and multiply the results by the terms of the
 series $1, \frac{1}{4}, \frac{1}{4^2}, \frac{1}{4^3},$ &c. so as to form the following series of
 equations, the number of which is n .

$$\frac{1}{\tan^2 s} = \frac{1}{2^2 \tan^2 \frac{1}{2} s} + \frac{1}{4} \tan^2 \frac{1}{2} s + \frac{1}{2}$$

$$\frac{1}{2^2 \tan^2 \frac{1}{2} s} = \frac{1}{4^2 \tan^2 \frac{1}{4} s} + \frac{1}{4} \tan^2 \frac{1}{4} s + \frac{1}{2 \cdot 4}$$

$$\frac{1}{4^2 \tan^2 \frac{1}{4} s} = \frac{1}{8^2 \tan^2 \frac{1}{8} s} + \frac{1}{4^3} \tan^2 \frac{1}{8} s + \frac{1}{2 \cdot 4^2}$$

$$\frac{1}{8^2 \tan^2 \frac{1}{8} s} = \frac{1}{16^2 \tan^2 \frac{1}{16} s} + \frac{1}{4^4} \tan^2 \frac{1}{16} s + \frac{1}{2 \cdot 4^3}$$

&c.

From these, by proceeding in all respects as in the article
 above quoted, that is, by adding, and rejecting what is common
 to each side of the sum, we get

$$\frac{1}{\tan^2 \frac{1}{2} s} = \left\{ \begin{array}{l} \frac{1}{2^{2n} \tan^2 \frac{s}{2^n}} \\ + \frac{1}{4} \tan^2 \frac{1}{2} s + \frac{1}{4} \tan^2 \frac{1}{4} s + \frac{1}{4^3} \tan^2 \frac{1}{8} s \dots + \frac{1}{4^n} \tan^2 \frac{1}{2^n} s \\ + \frac{1}{2} + \frac{1}{2 \cdot 4} + \frac{1}{2 \cdot 4^2} \dots + \frac{1}{2 \cdot 4^{n-1}} \end{array} \right.$$

Now,

Now, as we have found (Art. 36.) that $2^n \tan \frac{a}{2^n}$ expresses twice the area of the polygon AFF'F''F''' (Plate IX.), the numerical value of which we have there denoted by Q, it follows, that $2^{2n} \tan^2 \frac{s}{2^n} = \frac{1}{4} Q^2$. Moreover, the geometrical series

$$\frac{1}{2} + \frac{1}{2 \cdot 4} + \frac{1}{2 \cdot 4^2} \dots + \frac{1}{2 \cdot 4^{n-1}}$$

is equivalent to $\frac{2}{3} (1 - \frac{1}{4^n})$, therefore, by substitution and transposition, we get

$$\frac{1}{4Q^2} \left\{ \begin{aligned} & \frac{1}{\tan^2 s} - \frac{2}{3} (1 - \frac{1}{4^n}) \\ & - (\frac{1}{4} \tan^2 \frac{1}{2} s + \frac{1}{4^2} \tan^2 \frac{1}{4} s + \frac{1}{4^3} \tan^2 \frac{1}{8} s \dots + \frac{1}{4^n} \tan^2 \frac{s}{2^n}) \end{aligned} \right.$$

44. LET us now conceive n to be indefinitely great, then, as upon this hypothesis, Q becomes s , and $\frac{2}{3} (1 - \frac{1}{4^n})$ becomes

simply $\frac{2}{3}$, and the series whose terms were n in number, now

goes on *ad infinitum*, we have at last, after multiplying the whole expression by 4,

$$\frac{1}{Q^2} = \left\{ \begin{aligned} & \frac{4}{\tan^2 s} - \frac{8}{3} \\ & - (\tan^2 \frac{1}{2} s + \frac{1}{4} \tan^2 \frac{1}{4} s + \frac{1}{4^2} \tan^2 \frac{1}{8} s + \frac{1}{4^3} \tan^2 \frac{1}{16} s +, \&c.) \end{aligned} \right.$$

And this is one form of the series to be investigated.

45. THE same series, however, may be given under another form, better adapted to calculation. For since, by the nature of the hyperbola

$$ab^2 S + ord^2 S = ab \ 2 S, \text{ and } ab^2 S - ord^2 S = 1,$$

therefore, taking the sum and difference of the corresponding sides of these equations, we get

$$2 ab^2 S = ab \ 2 S + 1, \ 2 ord^2 S = ab \ 2 S - 1;$$

and hence, by dividing the latter of these equations by the former, and putting $\tan S$ instead of $\frac{ord S}{ab S}$, we find

$$\tan S = \frac{ab \ 2 S - 1}{ab \ 2 S + 1}.$$

FROM this formula, by substituting $s, \frac{1}{2}s, \frac{1}{4}s, \&c.$ instead of S , we obtain expressions for $\tan^2 s, \tan^2 \frac{1}{2}s, \tan^2 \frac{1}{4}s, \&c.$ These being substituted in the series, and afterwards s put instead of $2s, \frac{1}{2}s$ instead of $s, \frac{1}{4}s$ instead of $\frac{1}{2}s, \&c.$ (so as to produce a result involving only the abscissæ corresponding to the sector s , and its sub-multiples); and, finally, the whole being divided by 4, we shall get

$$\frac{1}{s^2} = \left\{ \begin{array}{l} \frac{ab s + 1}{ab s - 1} - \frac{2}{3} \\ - \left(\frac{1}{4} \frac{ab \frac{1}{2}s - 1}{ab \frac{1}{2}s + 1} + \frac{1}{4^2} \frac{ab \frac{1}{4}s - 1}{ab \frac{1}{4}s + 1} + \frac{1}{4^3} \frac{ab \frac{1}{8}s - 1}{ab \frac{1}{8}s + 1} +, \&c. \right) \end{array} \right.$$

and this expression is analogous to our second series for an arch of a circle, as given at Art. 17.

46. WE may now investigate what are the limits to the rate of convergency of this series, as also the limits to the sum of all its terms following any assigned term. With respect to the first of

of these inquiries, it appears, that the terms of the series, under its first form, (Art. 3) are exactly the squares of the corresponding terms of the former series, under its first form (Art. 36.), so that the one being written thus,

$$\frac{I}{s} = P - (T_{(1)} + T_{(2)} \dots + T_{(m)} + T_{(m+1)} + T_{(m+2)} +, \&c.)$$

the other will be

$$\frac{I}{s^2} = P' - (T^2_{(1)} + T^2_{(2)} \dots + T^2_{(m)} + T^2_{(m+1)} + T^2_{(m+2)} +, \&c.),$$

and here P and P' are put for the parts of the two expressions which do not follow the law of the remaining terms, but $T_{(1)}$, $T_{(2)}$, &c. denote the same quantities in both. Now, as each term in the former series has been proved to be greater than one-fourth of the term immediately before it (Art. 39) each term of the latter must be greater than one-sixteenth of the term immediately before it; and this is one limit to the rate of convergency.

AGAIN, as it has been proved (Art. 40.), that in the first series $T_{(n+2)} < \frac{T^2_{(n+1)}}{T_{(n)}}$, therefore, squaring, we have

$$T^2_{(n+2)} < \frac{T^4_{(n+1)}}{T^2_{(n)}}.$$

Now this quantity is a third proportional

to $T^2_{(n)}$ and $T^2_{(n+1)}$; hence it follows, that the greater limit of the rate of convergency in the two series is the very same; that is, each term is less than a third proportional to the two terms immediately before it.

As these limits to the rate of convergency differ from those of our second series for an arch of a circle (Art. 18.), only by the lesser limit in the one case corresponding to the greater in the other, and the contrary, it is sufficiently evident,

that by proceeding, as in the case of the circle, to determine limits to the sum of all the terms following any assigned term, we would obtain an analogous result, namely, that the sum of all the terms following any assigned term is greater than $\frac{1}{r^2}$ th of that term, but less than a third proportional to the difference of the two terms immediately before it, and the latter of the two.

47. IT now only remains to be considered, how the numerical values of the terms of the series are to be found. Now, this may evidently be done by computing the values of the quantities $ab \frac{1}{2} s$, $ab \frac{1}{4} s$, $ab \frac{1}{8} s$, &c. from the abscissa corresponding to the whole sector, and from one another by the known formula

$$ab \frac{1}{2} S = \sqrt{\frac{ab S + 1}{2}}$$

and thence the values of the quantities $\frac{ab \frac{1}{2} s - 1}{ab \frac{1}{2} s + 1}$, $\frac{ab \frac{1}{4} s - 1}{ab \frac{1}{4} s + 1}$, &c.

OR we may deduce each of these from that which precedes it, by a formula analogous to that found at Art. 21. in the case of the circle, and which may be investigated as follows. Let

$$\frac{ab S - 1}{ab S + 1} = t, \text{ and } \frac{ab \frac{1}{2} S - 1}{ab \frac{1}{2} S + 1} = t', \text{ then we have } ab S = \frac{1+t}{1-t},$$

$$\text{and } \frac{ab S + 1}{2} = \frac{1}{1-t}; \text{ we have also } ab \frac{1}{2} S = \frac{1+t'}{1-t'}; \text{ and}$$

$$\text{since by the nature of the hyperbola } ab \frac{1}{2} S = \sqrt{\frac{ab S + 1}{2}};$$

therefore

therefore $\frac{1}{\sqrt{1-t}} = \frac{1+t'}{1-t'}$, and hence

$$t' = \frac{1 - \sqrt{1-t}}{1 + \sqrt{1-t}}$$

which is the formula required.

48. THE result of the whole investigation of this second series, for the area of an hyperbolic sector, may now be collected into one point of view, as follows.

PUTTING s for the area of the sector, let its corresponding abscissa be denoted by the abbreviated expression $ab s$; also let the abscissæ corresponding to the other sectors which are its sub-multiples be denoted similarly.

COMPUTE the series of quantities $ab \frac{1}{2} s$, $ab \frac{1}{4} s$, $ab \frac{1}{8} s$, &c. from $ab s$, and one another, by the formula

$$ab \frac{1}{2} S = \sqrt{\frac{ab S + 1}{2}}$$

Then shall

$$\frac{1}{s^3} = \left\{ \begin{array}{l} \frac{ab s + 1}{ab s - 1} - \frac{2}{3} \\ - \left\{ \frac{1}{4} \frac{ab \frac{1}{2} s - 1}{ab \frac{1}{2} s + 1} + \frac{1}{4^2} \frac{ab \frac{1}{4} s - 1}{ab \frac{1}{4} s + 1} + \frac{1}{4^3} \frac{ab \frac{1}{8} s - 1}{ab \frac{1}{8} s + 1} \right. \\ \left. \dots + T_{(m)} + T_{(m+1)} + R \right\} \end{array} \right.$$

where R denotes the sum of all the terms following the term $T_{(m+1)}$, and this sum is always contained between the limits

$$\frac{1}{15} T_{(m+1)}, \text{ and } \frac{T_{(m+1)}^2}{T_{(m)} - T_{(m+1)}}$$

being greater than the former, but less than the latter. This last limit may also be otherwise expressed thus,

$$\frac{1}{15} T_{(m+1)} + \frac{(16 T_{(m+1)} - T_{(m)}) T_{(m+1)}}{15 (T_{(m)} - T_{(m+1)})}$$

OR compute the series of quantities $t, t', t'',$ &c. one from another by these formulæ

$$t = \frac{ab s - 1}{ab s + 1}, \quad t' = \frac{1 - \sqrt{1-t}}{1 + \sqrt{1+t}}, \quad t'' = \frac{1 - \sqrt{1-t'}}{1 + \sqrt{1+t'}}, \quad \&c.$$

Then shall

$$\frac{1}{s^2} = \frac{ab s + 1}{ab s - 1} - \frac{2}{3} - \left(\frac{1}{4} t' + \frac{1}{4^2} t'' + \frac{1}{4^3} t''' \dots + T_{(m)} + T_{(m+1)} + R \right),$$

the symbols $T_{(m)}, T_{(m+1)},$ and $R,$ being put to denote the same as before.

49. WE might now investigate other series for the quadrature of an hyperbolic sector, similar to the third and fourth series we have found for the rectification of an arch of a circle; but this inquiry would extend the Paper to too great a length. For this reason, and also because the manner of proceeding in the one case is exactly the same as has been followed in the other, it seems unnecessary, in the case of the hyperbola, to extend our inquiries farther. I shall therefore now proceed to the third and last object proposed in this Paper, namely, the investigation of formulæ for the calculation of logarithms, beginning with a few remarks that may serve to connect these formulæ with the common theory.

50. IT is usually shewn by writers on this subject, that all numbers whatever are considered as equal, or nearly equal, to one

one or other of the terms of a geometrical series whose first term is unity and common ratio, a number very nearly equal to unity, but a little greater; and any quantities proportional to the exponents of the terms of the series, are the logarithms of the numbers to which the terms are equal.

LOGARITHMS, then, being not absolute but relative quantities, we may assume any number whatever as that whose logarithm is unity; but a particular number being once chosen, the logarithms of all other numbers are thereby fixed.

HENCE it follows, that there may be different systems, according as unity is made the logarithm of one or another number; the logarithms of two given numbers, however, will always have the same ratio to each other in every system whatever; these properties which are commonly known, are mentioned here only for the sake of what is to follow, as we have already premised.

51. TAKING this view of the theory of logarithms as the foundation of our investigations,

LET us put r for the common ratio of the geometrical series,

x for any number or term of the series,

b for the number whose logarithm is unity,

y for the exponent of that power of r which is equal to x ,

m for the exponent of the power of r which is equal to b .

Then we have $x = r^y$, and $b = r^m$, and because by the nature of logarithms $\log x : \log b :: y : m$, therefore $\log x = \frac{y}{m} \times \log b$;

but by hypothesis $\log b = 1$, therefore $\log x = \frac{y}{m}$.

52. LET

52. LET v denote any number greater than unity, and p and n any two whole positive numbers; then, by a known formula

$$v^p - 1 = \frac{v - 1}{v} \{ v + v^2 + v^3 + v^4 \dots + v^p \},$$

$$v^n - 1 = \frac{v - 1}{v} \{ v + v^2 + v^3 + v^4 \dots + v^n \};$$

therefore, dividing each side of the first of these equations by the corresponding side of the second, we get

$$\frac{v^p - 1}{v^n - 1} = \frac{v + v^2 + v^3 + v^4 \dots + v^p}{v + v^2 + v^3 + v^4 \dots + v^n}$$

Now, v being by hypothesis greater than unity, the fraction on the right hand side of this equation is less than this other fraction

$$\frac{v^p + v^p + v^p + v^p \dots + v^p \text{ (to } p \text{ terms)}}{1 + 1 + 1 + 1 \dots + 1 \text{ (to } n \text{ terms)}} = \frac{p v^p}{n},$$

because it has manifestly a less numerator, and at the same time a greater denominator. The same fraction is, however, greater than this fraction

$$\frac{1 + 1 + 1 + 1 \dots + 1 \text{ (to } p \text{ terms)}}{v^n + v^n + v^n + v^n \dots + v^n \text{ (to } n \text{ terms)}} = \frac{p}{n v^n}$$

because it has a greater numerator, and a less denominator. Therefore,

$$\frac{v^p - 1}{v^n - 1} < \frac{p v^p}{n}, \quad \frac{v^p - 1}{v^n - 1} > \frac{p}{n v^n},$$

and hence, dividing the first of these expressions by v^p , and multiplying the second by v^n ,

$$\frac{p}{n} > \frac{v^p - 1}{v^p (v^n - 1)}, \quad \frac{p}{n} < \frac{v^n (v^p - 1)}{v^n - 1}. \quad (\alpha).$$

53. PUTTING v and p to denote, as in last article, it is manifest that the series

$$1 + v^{\frac{1}{p}} + v^{\frac{2}{p}} + v^{\frac{3}{p}} \dots + v^{\frac{p-1}{p}}$$

is greater than this other series

$$1 + 1 + 1 + 1 \dots + 1 \text{ (to } p \text{ terms)} = p,$$

but less than this series

$$v + v + v + v \dots + v \text{ (to } p \text{ terms)} = pv;$$

but by a known formula, the sum of the first of these three series is

$$\frac{v - 1}{\frac{1}{v^p} - 1}, \text{ therefore,}$$

$$\frac{v - 1}{\frac{1}{v^p} - 1} > p, \quad \frac{v - 1}{\frac{1}{v^p} - 1} < pv,$$

and hence it follows, that

$$\left. \begin{aligned} \frac{1}{v^p} < 1 + \frac{v - 1}{p}, \quad p \left(\frac{1}{v^p} - 1 \right) < v - 1, \\ \frac{1}{v^p} > 1 + \frac{v - 1}{pv}, \quad p \left(\frac{1}{v^p} - 1 \right) > 1 - \frac{1}{v}. \end{aligned} \right\} (\beta).$$

54. LET us now recur to the symbols r, x, b, y and m , whose values are assigned in Art. 51. and let us assume $y = p$, and $r = v^n$; then, from the two expressions (α) in Art. 52, we have

$$\frac{y}{n} >$$

$$\frac{y}{n} > \frac{1}{r^n} \cdot \frac{r^{\frac{y}{n}} - 1}{r - 1}, \quad \frac{y}{n} < r \cdot \frac{r^{\frac{y}{n}} - 1}{r - 1};$$

and hence, multiplying by n , and dividing by m ,

$$\frac{y}{m} > \frac{1}{r^n} \cdot \frac{n(r^{\frac{y}{n}} - 1)}{m(r - 1)}, \quad \frac{y}{m} < r \cdot \frac{n(r^{\frac{y}{n}} - 1)}{m(r - 1)}.$$

But $ry = x$, and $r^m = b$, (Art. 51.), from which it follows, that

$r^{\frac{y}{n}} = x^{\frac{1}{n}}$, and $r = b^{\frac{1}{m}}$; moreover, $\frac{y}{m} = \log x$; therefore, substituting,

we get

$$\log x > \frac{1}{x^{\frac{1}{n}}} \cdot \frac{n(x^{\frac{1}{n}} - 1)}{m(b^{\frac{1}{m}} - 1)}, \quad \log x < b^{\frac{1}{m}} \cdot \frac{n(x^{\frac{1}{n}} - 1)}{m(b^{\frac{1}{m}} - 1)},$$

and in these expressions n denotes any whole positive number whatever.

55. By subtracting the lesser of these limits to the logarithm of x from the greater, we find their difference to be

$$\frac{1}{x^{\frac{1}{n}}} \frac{n(x^{\frac{1}{n}} - 1)}{m(b^{\frac{1}{m}} - 1)} \times (b^{\frac{1}{m}} x^{\frac{1}{n}} - 1).$$

Now

Now we have found, that one factor of this expression, viz.

$$\frac{n(x^{\frac{1}{n}} - 1)}{x^{\frac{1}{n}} m(b^{\frac{1}{m}} - 1)}$$

cannot exceed the logarithm of x ; with re-

spect to the other factor $b^{\frac{1}{m}} x^{\frac{1}{n}} - 1$, since it appears from the first of the four formulæ (β), (Art. 53.), that $b^{\frac{1}{m}} < 1 + \frac{b-1}{m}$,

and $x^{\frac{1}{n}} < 1 + \frac{x-1}{n}$; therefore, multiplying $b^{\frac{1}{m}} x^{\frac{1}{n}} < (1 + \frac{b-1}{m})$

$(1 + \frac{x-1}{n})$, and hence

$$b^{\frac{1}{m}} x^{\frac{1}{n}} - 1 < \frac{b-1}{m} + \frac{x-1}{n} + \frac{(b-1)(x-1)}{mn}$$

Now as we may conceive m and n to be as great as we please, it is evident that this quantity, which exceeds the factor

$b^{\frac{1}{m}} x^{\frac{1}{n}} - 1$, may be smaller than any assignable quantity; there-

fore the product of the two factors, or the difference between the limits to the value of $\log x$, may, by taking m and n sufficiently great, be less than any assignable quantity.

UPON the whole, then, it appears, that the logarithm of x is a limit to which the two quantities

$$\frac{n(x^{\frac{1}{n}} - 1)}{x^{\frac{1}{n}} m(b^{\frac{1}{m}} - 1)}, \quad \frac{n(x^{\frac{1}{n}} - 1)}{b^{\frac{1}{m}} m(b^{\frac{1}{m}} - 1)}$$

continually approach when m and n are conceived to increase indefinitely, and to which each at last comes nearer than by any assignable difference, just as a circle is the limit to all the polygons which can be inscribed in it, or described about it.

56. THE two expressions $n(x^{\frac{1}{n}} - 1)$, $m(b^{\frac{1}{m}} - 1)$, which enter into these limits to the logarithm of x , and which are evidently functions of the same kind, have each a finite magnitude even when m or n is considered as greater than any assignable number; for since when v is greater than unity, and p any whole positive number, we have

$$p(v^{\frac{1}{p}} - 1) < v - 1, \quad p(v^{\frac{1}{p}} - 1) > 1 - \frac{1}{v}. \quad (\text{Art. 53.})$$

Therefore, supposing x and b both greater than 1, (which may always be done in the theory of logarithms), the expression $n(x^{\frac{1}{n}} - 1)$ is necessarily contained between the limits $x - 1$ and $1 - \frac{1}{x}$; and in like manner, $m(b^{\frac{1}{m}} - 1)$ is between $b - 1$ and $1 - \frac{1}{b}$.

57. As the expression $m(b^{\frac{1}{m}} - 1)$ depends entirely upon the value of b , the number whose logarithm is assumed = 1, (and which is sometimes called the *basis* of the system), the limit to which it approaches when m increases indefinitely will be a constant quantity in a given system; but the limit to which

which $n(x^{\frac{1}{n}} - 1)$ approaches, when n is conceived to be indefinitely increased, will be variable, as it depends upon the particular value of the number x .

LET us therefore denote the limit of $m(b^{\frac{1}{m}} - 1)$, or that of $m(b^{\frac{1}{m}} - 1)$ $\frac{1}{b^{\frac{1}{m}}}$, (for they are evidently the same), by B, and then

in the system whose basis is b , the logarithm of x will be the limit of either of these two expressions

$$\frac{1}{x^{\frac{1}{n}}} \frac{n(x^{\frac{1}{n}} - 1)}{B}, \quad \frac{n(x^{\frac{1}{n}} - 1)}{B},$$

when n is conceived to increase indefinitely, or to speak briefly,

$$\log x = \frac{n(x^{\frac{1}{n}} - 1)}{B}, \text{ when } n \text{ is indefinitely great.}$$

THE constant multiplier $\frac{1}{B}$ is what writers on the subject of logarithms have denominated the *modulus* of the system. As in NAPIER'S system it is unity, we have, n being indefinitely great,

Nap. $\log x = n(x^{\frac{1}{n}} - 1)$, and since in any system whatever

$B = m(b^{\frac{1}{m}} - 1)$, or $B = n(b^{\frac{1}{n}} - 1)$, for we may put m or n

indiscriminately ; therefore $B = \text{Nap. log } b$, and consequently

$$\log x \text{ (to basis } b) = \frac{\text{Nap. log } x}{\text{Nap. log } b},$$

as is commonly known.

58. SINCE, therefore, the logarithms of any proposed system may be deduced from those of NAPIER'S system, I shall throughout the rest of this Paper attend only to the formula

$$\text{Nap. log } x = n (x^{\frac{1}{n}} - 1), \quad n \text{ being indefinitely great.}$$

LET us then, agreeably to the mode of proceeding employed in the former part of this paper, assume the identical equation

$$\frac{X^2 + 1}{X^2 - 1} = \frac{X + 1}{2(X - 1)} + \frac{1}{2} \frac{X - 1}{X + 1}.$$

In this expression let $x^{\frac{1}{2}}$, $x^{\frac{1}{4}}$, $x^{\frac{1}{8}}$, $x^{\frac{1}{16}}$, &c. be substituted successively for X , and let the results be multiplied by the corresponding terms of the series, 1 , $\frac{1}{2}$, $\frac{1}{4}$, &c. Thus there will be formed a series of equations, which, putting n for their number, and m for 2^n , may stand as follows :

$$\frac{x + 1}{x - 1}$$

$$\frac{x + 1}{x - 1} = \frac{x^{\frac{1}{2}} + 1}{2(x^{\frac{1}{2}} - 1)} + \frac{1}{2} \frac{x^{\frac{1}{2}} - 1}{x^{\frac{1}{2}} + 1},$$

$$\frac{x^{\frac{1}{2}} + 1}{2(x^{\frac{1}{2}} - 1)} = \frac{x^{\frac{1}{4}} + 1}{4(x^{\frac{1}{4}} - 1)} + \frac{1}{4} \frac{x^{\frac{1}{4}} - 1}{x^{\frac{1}{4}} + 1},$$

$$\frac{x^{\frac{1}{4}} + 1}{4(x^{\frac{1}{4}} - 1)} = \frac{x^{\frac{1}{8}} + 1}{8(x^{\frac{1}{8}} - 1)} + \frac{1}{8} \frac{x^{\frac{1}{8}} - 1}{x^{\frac{1}{8}} + 1},$$

$$\frac{x^{\frac{1}{8}} - 1}{8(x^{\frac{1}{8}} + 1)} = \frac{x^{\frac{1}{16}} + 1}{16(x^{\frac{1}{16}} - 1)} + \frac{1}{16} \frac{x^{\frac{1}{16}} - 1}{x^{\frac{1}{16}} + 1},$$

.....

$$\frac{2(x^{\frac{2}{m}} + 1)}{m(x^{\frac{2}{m}} - 1)} = \frac{x^{\frac{1}{m}} + 1}{m(x^{\frac{1}{m}} - 1)} + \frac{1}{2^m} \frac{x^{\frac{1}{m}} - 1}{x^{\frac{1}{m}} + 1},$$

LET the sum of these equations be now taken, and the quantities found on both sides of the result rejected, then, after

ter transposing, we get

$$\frac{x^{\frac{1}{m}} + 1}{m(x^{\frac{1}{m}} - 1)} = \left\{ \begin{array}{l} \frac{x + 1}{x - 1} \\ - \left(\frac{1}{2} \frac{x^{\frac{1}{2}} - 1}{x^{\frac{1}{2}} + 1} + \frac{1}{4} \frac{x^{\frac{1}{4}} - 1}{x^{\frac{1}{4}} + 1} + \frac{1}{8} \frac{x^{\frac{1}{8}} - 1}{x^{\frac{1}{8}} + 1} + \frac{1}{16} \frac{x^{\frac{1}{16}} - 1}{x^{\frac{1}{16}} + 1} \dots \right. \\ \left. + \frac{1}{2^n} \frac{x^{\frac{1}{m}} - 1}{x^{\frac{1}{m}} + 1} \right) \end{array} \right.$$

THIS equation, which is identical, holds true whatever be the value of n . Let us now, however, suppose, that n is indefinitely great, then the series will go on *ad infinitum*, and $m = 2^n$ will become indefinitely great; but this being the case,

$x^{\frac{1}{m}} + 1$, which is always less than $2 + \frac{x - 1}{m}$, (Art. 53.), will

become simply 2; and $m(x^{\frac{1}{m}} - 1)$ will become Nap. log x , (Art. 57.); therefore substituting these limits, and dividing by 2, we have

$$\frac{1}{\log x} = \left\{ \begin{array}{l} \frac{1}{2} \frac{x + 1}{x - 1} \\ - \left(\frac{1}{4} \frac{x^{\frac{1}{2}} - 1}{x^{\frac{1}{2}} + 1} + \frac{1}{8} \frac{x^{\frac{1}{4}} - 1}{x^{\frac{1}{4}} + 1} + \frac{1}{16} \frac{x^{\frac{1}{8}} - 1}{x^{\frac{1}{8}} + 1} + \frac{1}{32} \frac{x^{\frac{1}{16}} - 1}{x^{\frac{1}{16}} + 1} + \dots \right) \\ \text{\&c.} \end{array} \right.$$

and

and this is the first series which I propose to investigate for the calculation of logarithms.

59. THE series just now found agreeing exactly in its form with our first series for an hyperbolic sector, (Art. 40.), as it ought to do, will of course have the same limits to the rate of its convergency, and to the sum of all its terms, following any proposed term. As the latter of these have been deduced from the former, in the case of the hyperbola, by a process purely analytical, and the same as we have followed in treating of the rectification of the circle, it is not necessary to repeat their investigation in this place. The limits to the rate of convergency, however, having been made to depend partly upon the nature of the curve, it may be proper, in the present inquiry, to deduce them entirely from the analytical formula which has been made the basis of the investigation.

LET any three successive terms of the series of quantities

$$\frac{x^{\frac{1}{2}} - 1}{x^{\frac{1}{2}} + 1}, \frac{x^{\frac{1}{4}} - 1}{x^{\frac{1}{4}} + 1}, \text{ \&c. be denoted by } t, t' \text{ and } t''; \text{ then it is}$$

evident from the formula, (Art. 58.), that the relation of these quantities to one another will be expressed by the equations

$$\frac{2}{t} = \frac{1}{t'} + t', \quad \frac{2}{t'} = \frac{1}{t''} + t''.$$

From the first of these we get $2t' = t(1 + t'^2)$, now each of the quantities $t, t', \text{ \&c. being evidently less than unity, it follows, that } 1 + t'^2 < 2$, but > 1 , and therefore that $2t' < 2t$, and $t' < t$; also that $2t' > t$, and $t' > \frac{1}{2}t$. Hence it appears,

in

in the first place, that each term of our series, taking its coefficient into account, is greater than one-fourth of the term before it.

AGAIN, because $\frac{t'}{t} = \frac{1}{2}(1+t'^2)$; and, similarly, $\frac{t''}{t'} = \frac{1}{2}(1+t'^2)$, and it having been proved that $t' < t$, so that similarly, $t'' < t'$, therefore $\frac{1}{2}(1+t'^2) < \frac{1}{2}(1+t'^2)$, and consequently $\frac{t''}{t'} < \frac{t'}{t}$, and $t'' < \frac{t'^2}{t}$. Thus it appears, that each of the quantities t'' , &c. is

less than a third proportional to the two immediately before it, and the same must also be true of the terms of the series.

60. UPON the whole, then, our first series for the calculation of logarithms may be expressed as follows :

$$\frac{1}{\log x} = \frac{1}{2} \frac{x+1}{x-1} - \left(\frac{1}{4} \frac{x^{\frac{1}{2}}-1}{x^{\frac{1}{2}}+1} + \frac{1}{8} \frac{x^{\frac{1}{4}}-1}{x^{\frac{1}{4}}+1} + \frac{1}{16} \frac{x^{\frac{1}{8}}-1}{x^{\frac{1}{8}}+1} \dots \right. \\ \left. + T_{(m)} + T_{(m+1)} + R \right);$$

and here, as in the former series, $T_{(m)}$ and $T_{(m+1)}$ denote any two succeeding terms, and R is a quantity greater than $\frac{1}{3}T_{(m+1)}$, but less than a third proportional to $T_{(m)} - T_{(m+1)}$ and $T_{(m+1)}$; or it is less than

$$\frac{1}{3} T_{(m+1)} + \frac{4 T_{(m+1)} - T_{(m)}}{3 (T_{(m)} - T_{(m+1)})} T_{(m+1)}.$$

61. THAT

61. THAT we may investigate a second series, we must take the square of the formula, (Art. 58.), which will be

$$\left(\frac{X^2 + 1}{X^2 - 1}\right)^2 = \frac{(X + 1)^2}{4(X - 1)^2} + \frac{1}{4} \left(\frac{X - 1}{X + 1}\right)^2 + \frac{1}{2}.$$

From this expression, proceeding exactly as in Art. 58. we form the following series of equations,

$$\frac{(x + 1)^2}{(x - 1)^2} = \frac{(x^{\frac{1}{2}} + 1)^2}{4(x^{\frac{1}{2}} - 1)^2} + \frac{1}{4} \left(\frac{x^{\frac{1}{2}} - 1}{x^{\frac{1}{2}} + 1}\right)^2 + \frac{1}{2},$$

$$\frac{(x^{\frac{1}{2}} + 1)^2}{4(x^{\frac{1}{2}} - 1)^2} = \frac{(x^{\frac{1}{4}} + 1)^2}{4^2(x^{\frac{1}{4}} - 1)^2} + \frac{1}{4^2} \left(\frac{x^{\frac{1}{4}} - 1}{x^{\frac{1}{4}} + 1}\right)^2 + \frac{1}{2 \cdot 4},$$

$$\frac{(x^{\frac{1}{4}} + 1)^2}{4^2(x^{\frac{1}{4}} - 1)^2} = \frac{(x^{\frac{1}{8}} + 1)^2}{4^3(x^{\frac{1}{8}} - 1)^2} + \frac{1}{4^3} \left(\frac{x^{\frac{1}{8}} - 1}{x^{\frac{1}{8}} + 1}\right)^2 + \frac{1}{2 \cdot 4^2},$$

.....

$$\frac{4(x^{\frac{1}{2^n}} + 1)^2}{m^2(x^{\frac{1}{2^n}} - 1)^2} = \frac{(x^{\frac{1}{2^{n-1}}} + 1)^2}{m^2(x^{\frac{1}{2^{n-1}}} - 1)^2} + \frac{1}{4^n} \left(\frac{x^{\frac{1}{2^{n-1}}} - 1}{x^{\frac{1}{2^{n-1}}} + 1}\right)^2 + \frac{1}{2 \cdot 4^{n-1}},$$

Here n denotes the number of equations, and m is put for 2^n . Let the sum of the corresponding sides of these equations be taken, and the quantities common to each rejected, as usual, and

the result, after transposition, will be

$$\frac{(x^{\frac{1}{m}} + 1)^2}{m^2 (x^{\frac{1}{m}} - 1)^2} = \left\{ \begin{aligned} & \left(\frac{x+1}{x-1} \right)^2 - \left(\frac{1}{2} + \frac{1}{2 \cdot 4} + \frac{1}{2 \cdot 4^2} + \frac{1}{2 \cdot 4^3} \dots + \frac{1}{2 \cdot 4^{n-1}} \right) \\ & - \left\{ \frac{1}{4} \left(\frac{x^{\frac{1}{2}} - 1}{x^{\frac{1}{2}} + 1} \right)^2 + \frac{1}{4^2} \left(\frac{x^{\frac{1}{4}} - 1}{x^{\frac{1}{4}} + 1} \right)^2 + \frac{1}{4^3} \left(\frac{x^{\frac{1}{8}} - 1}{x^{\frac{1}{8}} + 1} \right)^2 \dots \right. \\ & \left. + \frac{1}{4^n} \left(\frac{x^{\frac{1}{m}} - 1}{x^{\frac{1}{m}} + 1} \right)^2 \right\} \end{aligned} \right.$$

This equation holds true when n is any whole positive number whatever. But if we suppose it indefinitely great, then the two series will go on *ad infinitum*, and the limit of the numerical se-

ries will be $\frac{2}{3}$, also the limit of $(x^{\frac{1}{m}} + 1)^2$ will be 4, and the li-

mit of $m^2 (x^{\frac{1}{m}} - 1)^2$ will be $\log^2 x$, (Art. 57.); therefore, sub-

stituting these limits, and also putting $\frac{4x}{(x-1)^2} + \frac{1}{3}$ for

$\left(\frac{x+1}{x-1} \right)^2 - \frac{2}{3}$, and dividing the whole expression by 4, we

get

$$\frac{1}{\log^2 x} =$$

$$\frac{1}{\log^2 x} = \left\{ \begin{array}{l} \frac{x}{(x-1)^2} + \frac{1}{12} \\ - \left\{ \frac{1}{4^2} \left(\frac{x^{\frac{1}{2}} - 1}{x^{\frac{1}{2}} + 1} \right)^2 + \frac{1}{4^3} \left(\frac{x^{\frac{1}{4}} - 1}{x^{\frac{1}{4}} + 1} \right)^2 + \frac{1}{4^4} \left(\frac{x^{\frac{1}{8}} - 1}{x^{\frac{1}{8}} + 1} \right)^2 + \right. \\ \left. \&c. \right\} \end{array} \right.$$

and thus we have obtained a second series for the logarithm of a number, which, by putting $t, t', \&c.$ instead of the fractions

$$\frac{x^{\frac{1}{2}} - 1}{x^{\frac{1}{2}} + 1}, \frac{x^{\frac{1}{4}} - 1}{x^{\frac{1}{4}} + 1}, \&c. \text{ and remarking that the relation which}$$

the quantities $t, t', \&c.$ have to one another is identical with that of the quantities $\tan s, \tan \frac{1}{2}s, \&c.$ (Art. 35.), it will appear to be the same as our second series for the area of an hyperbolic sector, (Art. 43.). Of course it will have the same limits to the rate of its convergency, and to the sum of all its terms following any given term. Now these have been found without any reference to the geometrical properties of the curve, therefore it is not necessary to repeat their investigation.

62. WE must now transform our series upon principles purely analytical, so as to suit it to calculation. And, in the first

place, because $\left(\frac{x-1}{x+1} \right)^2 = \frac{x^2 - 2x + 1}{x^2 + 2x + 1} = \frac{\frac{1}{2}(x + \frac{1}{x}) - 1}{\frac{1}{2}(x + \frac{1}{x}) + 1}$ if

T t 2

we

we put $\frac{1}{2} \left(x + \frac{1}{x} \right) = X$, it follows, that $\left(\frac{x-1}{x+1} \right)^2 = \frac{X-1}{X+1}$.

In like manner, putting $\frac{1}{2} \left(x^{\frac{1}{2}} + \frac{1}{x^{\frac{1}{2}}} \right) = X'$, and $\frac{1}{2} \left(x^{\frac{1}{4}} - \frac{1}{x^{\frac{1}{4}}} \right)$

$$= X'', \text{ we have } \left(\frac{x^{\frac{1}{2}}-1}{x^{\frac{1}{2}}+1} \right)^2 = \frac{X'-1}{X'+1}, \text{ and } \left(\frac{x^{\frac{1}{4}}-1}{x^{\frac{1}{4}}+1} \right)^2 = \frac{X''-1}{X''+1},$$

&c. Again, because $X' = \frac{1}{2} \left(x^{\frac{1}{2}} + \frac{1}{x^{\frac{1}{2}}} \right)$, therefore $2X'^2 =$

$$\frac{1}{2} \left(x + \frac{1}{x} \right) + 1, \text{ but } \frac{1}{2} \left(x + \frac{1}{x} \right) = X, \text{ therefore } 2X'^2 = X + 1$$

and $X' = \sqrt{\frac{X+1}{2}}$. In like manner, it will appear, that

$$X'' = \sqrt{\frac{X'+1}{2}}, \text{ \&c.}$$

63. FROM the preceding investigation it appears, upon the whole, that our second series for the calculation of a logarithm may be expressed as follows.

PUTTING x for any number, let a series of quantities $X, X', X'', X''', \&c.$ be found such that

$$X = \frac{1}{2} \left\{ x + \frac{1}{x} \right\}, X' = \sqrt{\frac{X+1}{2}}, X'' = \sqrt{\frac{X'+1}{2}}, \&c.$$

Then will

$$\frac{1}{\log^2 x} =$$

$$\frac{1}{\log^2 x} = \left\{ \begin{array}{l} \frac{x}{(x-1)^2} + \frac{1}{12} \\ - \left\{ \frac{1}{4^2} \frac{X'-1}{X'+1} + \frac{1}{4^3} \frac{X''-1}{X''+1} + \frac{1}{4^4} \frac{X'''-1}{X'''+1} \dots \right. \\ \left. + T_{(m)} + T_{(m+1)} + R \right\}; \end{array} \right.$$

and here $T_{(m)}$, $T_{(m+1)}$, are put for any two successive terms of the series, and R for the sum of all the following terms: And

in every case R is greater than $\frac{1}{15} T_{(m+1)}$, but less than

$$\frac{1}{15} T_{(m+1)} + \frac{16 T_{(m+1)} - T_{(m)}}{15 (T_{(m)} - T_{(m+1)})} T_{(m+1)}.$$

64. FROM the analogy of the two formulæ from which we have deduced the series for the rectification of an arch of a circle, and for the calculation of logarithms, it is easy to infer that there will be corresponding series for the resolution of each of these problems. And as the two preceding series for a logarithm have been investigated in the very same way as the first two series for an arch of a circle, so, by proceeding exactly as in the investigation of the third and fourth series for the circle, we may obtain a third and fourth series for a logarithm. The mode of deduction, then, being the same in both cases, and also sufficiently evident, I shall simply state the result of the investigation of a series for logarithms which is analogous to our fourth series for an arch of a circle, (Art. 28.).

LET x be any number, and X, X', X'', X''' , &c. a series of quantities formed from x , and one another, as specified in the beginning of the last article. Then

$$\frac{1}{\log^4 x} =$$

$$\frac{1}{\log^4 x} = \left\{ \begin{array}{l} \frac{x(x^2 + 4x + 1)}{6(x-1)^4} - \frac{1}{8.9.10} \\ + \frac{1}{3.16^2} \frac{X + 12X' - 13}{X + 4X' + 3} + \frac{1}{3.16^3} \frac{X' + 12X'' - 13}{X' + 4X'' + 3} \\ + \frac{1}{3.16^4} \frac{X'' + 12X''' + 13}{X'' + 4X''' + 3} +, \&c. \end{array} \right.$$

The terms of this series approach continually to those of a geometrical series, of which the common ratio is $\frac{1}{64}$: and hence it follows, that the sum of all the terms after any assigned term, approaches the nearer to $\frac{1}{63}$ of that term, according as it is more advanced in the series.

65. BESIDES the foregoing, our method furnishes yet another kind of expression for the logarithm of a number, namely, a product consisting of an infinite number of factors, which approach continually to unity. Such an expression may be investigated as follows. From the identical equation

$$X - 1 = (X^{\frac{1}{2}} - 1)(X^{\frac{1}{2}} + 1).$$

LET there be formed the series of equations

$$x - 1 = 2(x^{\frac{1}{2}} - 1) \frac{x^{\frac{1}{2}} + 1}{2},$$

$$2(x^{\frac{1}{2}} - 1) = 4(x^{\frac{1}{4}} - 1) \frac{x^{\frac{1}{4}} + 1}{2},$$

$$4(x^{\frac{1}{4}} - 1) = 8(x^{\frac{1}{8}} - 1) \frac{x^{\frac{1}{8}} + 1}{2},$$

.....

$$\frac{m}{2}(x^{\frac{2}{m}} - 1) = m(x^{\frac{1}{m}} - 1) \frac{x^{\frac{1}{m}} + 1}{2},$$

here

here m is put for any integer power of 2. Let the product of the corresponding sides of these equations be now taken, and the common factors rejected, and the result will be

$$x - 1 = m \left(x^{\frac{1}{m}} - 1 \right) \frac{x^{\frac{1}{2}} + 1}{2} \frac{x^{\frac{1}{4}} + 1}{2} \frac{x^{\frac{1}{8}} + 1}{2} \dots \frac{x^{\frac{1}{m}} + 1}{2},$$

and hence

$$m \left(x^{\frac{1}{m}} - 1 \right) = (x - 1) \frac{2}{x^{\frac{1}{2}} + 1} \frac{2}{x^{\frac{1}{4}} + 1} \frac{2}{x^{\frac{1}{8}} + 1} \dots \frac{2}{x^{\frac{1}{m}} + 1}.$$

This equation holds true, m being any power of 2 whatever.

LET us, however, conceive it indefinitely great. Then the number of factors will become infinite, and $m \left(x^{\frac{1}{m}} - 1 \right)$ will become Nap. log x (Art. 57.). Therefore,

$$\text{Nap. log } x = (x - 1) \frac{2}{x^{\frac{1}{2}} + 1} \frac{2}{x^{\frac{1}{4}} + 1} \frac{2}{x^{\frac{1}{8}} + 1} \frac{2}{x^{\frac{1}{16}} + 1}, \text{ \&c.}$$

ad infinitum.

THE product of any finite number of these factors being always a function of this form $m \left(x^{\frac{1}{m}} - 1 \right)$ will of course be greater

than log x , (Art. 54.). However, the function $\frac{1}{x^{\frac{1}{m}}} m \left(x^{\frac{1}{m}} - 1 \right)$

or $m \left(1 - \frac{1}{x^{\frac{1}{m}}} \right)$, being in like manner expanded into an infi-

nite

nite product, we get from it

$$\log x = \left(1 - \frac{1}{x}\right) \frac{2}{\frac{1}{x^2} + 1} \frac{2}{\frac{1}{x^4} + 1} \frac{2}{\frac{1}{x^8} + 1} \frac{2}{\frac{1}{x^{16}} + 1}, \text{ \&c.}$$

ad infinitum.

and the product of any finite number of factors of this expression will always be less than $\log x$.

THESE formulæ, which are analogous to that given by EULER for an arch of a circle, (see Art. 33.), are not inelegant, considered as analytical transformations. It does not seem, however, that without some analytical artifice, they can be applied with advantage to the actual calculation of logarithms, by reason of the great labour which would be necessary to obtain a result tolerably accurate.

66. I SHALL now conclude this Paper, with some examples of the application of the formulæ to the computation of the length of one-fourth the circumference of a circle whose radius is unity, (which is the extreme and the most unfavourable case), and to the computation of a logarithm; as also of the *modulus* of the common system of logarithms, which is the reciprocal of NAPIER's logarithm of 10.

EXAMPLE

EXAMPLE I. The length of an arch of 90° , computed to 12 places of decimals, by means of the first series, (Art. 12.). Here $a = 90^\circ$.

$\frac{1}{\tan a} = \cot a = 0$	$\tan \frac{1}{8} a = 0.0245486221089$
$\tan \frac{1}{2} a = 1$	$\tan \frac{1}{16} a = 0.012272462379.$
$\tan \frac{1}{4} a = 0.4142135623731$	$\tan \frac{1}{32} a = 0.006136000157.$
$\tan \frac{1}{8} a = 0.1989123673796$	$\tan \frac{1}{64} a = 0.003067971201.$
$\tan \frac{1}{16} a = 0.0984914033571$	$\tan \frac{1}{128} a = 0.00153398194..$
$\tan \frac{1}{32} a = 0.0491268497694$	$\tan \frac{1}{256} a = 0.00076699054..$

$\frac{1}{2} \tan \frac{1}{2} a = .500\ 000\ 000\ 000\ 0$
$\frac{1}{4} \tan \frac{1}{4} a = .103\ 553\ 390\ 593\ 3$
$\frac{1}{8} \tan \frac{1}{8} a = .024\ 864\ 045\ 922\ 5$
$\frac{1}{16} \tan \frac{1}{16} a = .006\ 155\ 712\ 709\ 8$
$\frac{1}{32} \tan \frac{1}{32} a = .001\ 535\ 214\ 055\ 3$
$\frac{1}{64} \tan \frac{1}{64} a = .000\ 383\ 572\ 220\ 5$
$\frac{1}{128} \tan \frac{1}{128} a = .000\ 095\ 878\ 612\ 3$
$\frac{1}{256} \tan \frac{1}{256} a = .000\ 023\ 968\ 750\ 6$
$\frac{1}{512} \tan \frac{1}{512} a = .000\ 005\ 992\ 131\ 3$
$\frac{1}{1024} \tan \frac{1}{1024} a = .000\ 001\ 498\ 029\ 3$
$\frac{1}{2048} \tan \frac{1}{2048} a = .000\ 000\ 374\ 507\ 1$

S < .00000012483577
 S > .00000012483565

Hence S = .000 000 124 835 7

$\frac{1}{a} = .636\ 619\ 772\ 367\ 7$

Arch of 90° , or $a = 1.570\ 796\ 326\ 795.$

EXAMPLE II. The length of an arch of 90° , computed by the second series, (Art. 22.).

$\text{cof } a = 0$	$\text{cof } \frac{1}{8} a = 0.99518472667..$
$\text{cof } \frac{1}{2} a = 0.7071067811865$	$\text{cof } \frac{1}{4} a = 0.99879545621..$
$\text{cof } \frac{1}{4} a = 0.9238795325113$	$\text{cof } \frac{1}{8} a = 0.9996988187...$
$\text{cof } \frac{1}{8} a = 0.980785280403.$	

Amount of positive terms, $\frac{1}{4} \frac{1 + \text{cof } a}{1 - \text{cof } a} + \frac{1}{8} = \frac{5}{12} = \underline{.416\ 666\ 666\ 666\ 7}$

$$\frac{1}{4^2} \frac{1 - \text{cof } \frac{1}{2} a}{1 + \text{cof } \frac{1}{2} a} = .010\ 723\ 304\ 703\ 4$$

$$\frac{1}{4^3} \frac{1 - \text{cof } \frac{1}{4} a}{1 + \text{cof } \frac{1}{4} a} = .000\ 618\ 220\ 779\ 6$$

$$\frac{1}{4^4} \frac{1 - \text{cof } \frac{1}{8} a}{1 + \text{cof } \frac{1}{8} a} = .000\ 037\ 892\ 799\ 0$$

$$\frac{1}{4^5} \frac{1 - \text{cof } \frac{1}{16} a}{1 + \text{cof } \frac{1}{16} a} = .000\ 002\ 356\ 882\ 2$$

$$\frac{1}{4^6} \frac{1 - \text{cof } \frac{1}{32} a}{1 + \text{cof } \frac{1}{32} a} = .000\ 000\ 147\ 127\ 6$$

$$\frac{1}{4^7} \frac{1 - \text{cof } \frac{1}{64} a}{1 + \text{cof } \frac{1}{64} a} = .000\ 000\ 009\ 192\ 7$$

$S < .000\ 000\ 000\ 612\ 8$
 $S > .000\ 000\ 000\ 612\ 6$

Hence $S = .000\ 000\ 000\ 612\ 7$

Amount of negative terms, $\underline{.011\ 381\ 932\ 097\ 2}$

Difference between the positive } or $\frac{1}{a^2} = \underline{.405\ 284\ 734\ 569\ 5}$
 and negative terms, }

$$\frac{1}{a} = .636\ 619\ 772\ 367\ 7$$

Arch of 90° , or $a = 1.570\ 796\ 326\ 795.$

EXAMPLE

EXAMPLE III. The length of an arch of 90° , calculated from the fourth series, (Art. 28.).

$$\begin{aligned} \operatorname{cof} a &= 0 & \operatorname{cof} \frac{1}{8} a &= 0.980\ 785\ 280\dots \\ \operatorname{cof} \frac{1}{2} a &= 0.707\ 106\ 781\ 186\ 5 & \operatorname{cof} \frac{1}{4} a &= 0.995\ 184\ 7\dots\dots \\ \operatorname{cof} \frac{1}{4} a &= 0.923\ 879\ 532\ 51. & \operatorname{cof} \frac{1}{32} a &= 0.998\ 80\dots\dots \end{aligned}$$

$$\frac{1}{3 \cdot 16^2} \frac{13 - \operatorname{cof} a + 12 \operatorname{cof} \frac{1}{2} a}{3 + \operatorname{cof} a - 4 \operatorname{cof} \frac{1}{2} a} = .163\ 053\ 902\ 010\ 8$$

$$\frac{7}{8 \cdot 8 \cdot 9 \cdot 10} = .001\ 215\ 277\ 777\ 8$$

Amount of positive terms, .164 269 179 788 6

$$\frac{1}{3 \cdot 16^3} \frac{13 - \operatorname{cof} \frac{1}{2} a - 12 \operatorname{cof} \frac{1}{4} a}{3 + \operatorname{cof} \frac{1}{2} a + 4 \operatorname{cof} \frac{1}{4} a} = .000\ 013\ 261\ 796\ 5$$

$$\frac{1}{3 \cdot 16^4} \frac{13 - \operatorname{cof} \frac{1}{4} a - 12 \operatorname{cof} \frac{1}{8} a}{3 + \operatorname{cof} \frac{1}{4} a + 4 \operatorname{cof} \frac{1}{8} a} = .000\ 000\ 198\ 794\ 2$$

$$\frac{1}{3 \cdot 16^5} \frac{13 - \operatorname{cof} \frac{1}{8} a - 12 \operatorname{cof} \frac{1}{16} a}{3 + \operatorname{cof} \frac{1}{8} a + 4 \operatorname{cof} \frac{1}{16} a} = .000\ 000\ 003\ 074\ 4$$

$$\frac{1}{3 \cdot 16^6} \frac{13 - \operatorname{cof} \frac{1}{16} a - 12 \operatorname{cof} \frac{1}{32} a}{3 + \operatorname{cof} \frac{1}{16} a + 4 \operatorname{cof} \frac{1}{32} a} = .000\ 000\ 000\ 047\ 8$$

Each of the remaining terms, being nearly $\frac{1}{8^4}$ th of the term before it, their sum will be nearly $\frac{1}{8^3}$ of the last term, or } .000 000 000 000 8

Amount of negative terms, .000 013 463 713 7

Difference between the positive and negative terms, or } $\frac{1}{a^2} = .164\ 255\ 716\ 074\ 9$

$$\frac{1}{a^3} = .405\ 284\ 734\ 569\ 3$$

$$\frac{1}{a} = .636\ 619\ 772\ 367\ 6$$

Arch of 90° , or $a = 1.570\ 796\ 326\ 795.$

EXAMPLE IV. The reciprocal of NAPIER'S logarithm of 10, (which is the *modulus* of the common system), calculated by the second series for logarithms. (See Art. 63.)

$$\begin{array}{ll}
 x = 10, \text{ and hence } X = 5.05 & X^{1v} = 1.010\ 373\ 154\ 20. \\
 X' = 1.739\ 252\ 713\ 092\ 7 & X^v = 1.002\ 589\ 934\ 6. \\
 X'' = 1.170\ 310\ 367\ 614\ 6 & X^{vi} = 1.000\ 647\ 274 \dots \\
 X''' = 1.041\ 707\ 820\ 748. & X^{vii} = 1.000\ 161\ 805 \dots
 \end{array}$$

$$\frac{x}{(x-1)^2} = .123\ 456\ 790\ 123\ 5$$

$$\frac{1}{1-x} = .083\ 333\ 333\ 333\ 3$$

Sum of positive terms, .206 790 123 456 8

$$\frac{1}{4} \frac{X' - 1}{X' + 1} = .016\ 867\ 116\ 475\ 8$$

$$\frac{1}{4^2} \frac{X'' - 1}{X'' + 1} = .001\ 226\ 137\ 760\ 6$$

$$\frac{1}{4^3} \frac{X''' - 1}{X''' + 1} = .000\ 079\ 796\ 518\ 0$$

$$\frac{1}{4^4} \frac{X^{1v} - 1}{X^{1v} + 1} = .000\ 005\ 038\ 882\ 6$$

$$\frac{1}{4^5} \frac{X^v - 1}{X^v + 1} = .000\ 000\ 315\ 745\ 2$$

$$\frac{1}{4^6} \frac{X^{vi} - 1}{X^{vi} + 1} = .000\ 000\ 019\ 746\ 9$$

$$\frac{1}{4^7} \frac{X^{vii} - 1}{X^{vii} + 1} = .000\ 000\ 001\ 234\ 4$$

$$\left. \begin{array}{l}
 R > .0000000000822,9 \\
 R < .0000000000823,1
 \end{array} \right\} R = .000\ 000\ 000\ 082\ 3$$

Sum of negative terms, .018 178 426 445 8

$$\left. \begin{array}{l}
 \text{Difference of the positive} \\
 \text{and negative terms,}
 \end{array} \right\} \frac{1}{\log^2 10} = .188\ 611\ 697\ 011\ 0$$

$$\frac{1}{\log 10} = .434\ 294\ 481\ 903.$$

EXAMPLE

EXAMPLE V. NAPIER's logarithm of 10, calculated by the third series for logarithms. (See Art. 64.).

$$\begin{array}{rcl}
 x = 10, & X = 5.05 & X'' = 1.0417078207 \dots \\
 X' = 1.739252713093. & & X^{IV} = 1.01037315 \dots \\
 X'' = 1.17031036761. & & X^V = 1.0025899 \dots
 \end{array}$$

$$\frac{x(x^2 + 4x + 1)}{6(x-1)^4} = .0358177107148$$

$$\frac{1}{3 \cdot 16^2} \frac{X + 12X' - 13}{X + 4X' + 3} = .0011210934214$$

$$\frac{1}{3 \cdot 16^3} \frac{X' + 12X'' - 13}{X' + 4X'' + 3} = .0000240411229$$

$$\frac{1}{3 \cdot 16^4} \frac{X'' + 12X''' - 13}{X'' + 4X''' + 3} = .0000004092394$$

$$\frac{1}{3 \cdot 16^5} \frac{X''' + 12X^{IV} - 13}{X''' + 4X^{IV} + 3} = .0000000065357$$

$$\frac{1}{3 \cdot 16^6} \frac{X^{IV} + 12X^V - 13}{X^{IV} + 4X^V + 3} = .0000000001027$$

$$\frac{1}{8} \text{ of last term} = \text{sum of the remaining terms nearly, } \left. \begin{array}{l} \\ \\ \\ \\ \\ \end{array} \right\} .0000000000016$$

$$\text{From sum of positive terms, } = .0369632611385$$

$$\text{Subtract } \frac{1}{8 \cdot 9 \cdot 10} = .0013888888889$$

$$\text{There remains } \frac{1}{\log^4 10} = .0355743722496$$

$$\frac{1}{\log^2 10} = .1886116970113$$

$$\frac{1}{\log 10} = .434294481903$$

EXAMPLE

EXAMPLE VI. To shew that the series investigated in this Paper are applicable in every case, whether the number whose logarithm is required be large or small, let it be required to calculate the common logarithm of the large prime number 1243 to seven decimal places, by the second series, (Art. 63.).

$x = 1243$	$X'' = 1.42356148$
$X = 621.50040225$	$X^{IV} = 1.10080913$
$X' = 17.64228446$	$X^V = 1.0248925.$
$X'' = 3.05305457$	$X^{VI} = 1.006204. .$

$$\frac{x}{(x-1)^2} = .000\ 805\ 801$$

$$\frac{1}{1^2} = .083\ 333\ 333.$$

Sum of positive terms, .084 139 134

$$\frac{1}{4^2} \frac{X' - 1}{X' + 1} = .055\ 794\ 813$$

$$\frac{1}{4^3} \frac{X'' - 1}{X'' + 1} = .007\ 914\ 766$$

$$\frac{1}{4^4} \frac{X''' - 1}{X''' + 1} = .000\ 682\ 688$$

$$\frac{1}{4^5} \frac{X^{IV} - 1}{X^{IV} + 1} = .000\ 046\ 861$$

$$\frac{1}{4^6} \frac{X^V - 1}{X^V + 1} = .000\ 003\ 001$$

$$\frac{1}{4^7} \frac{X^{VI} - 1}{X^{VI} + 1} = .000\ 000\ 189$$

$$\left. \begin{array}{l} R > .000000012,6 \\ R < .000000012,7 \end{array} \right\} R = .000\ 000\ 013$$

Sum of negative terms, .064 442 331

$$\frac{1}{\text{Nap. log}^2 x} = .019\ 696\ 803$$

$$\frac{1}{\text{Nap. log} x} = .140\ 345\ 300$$

$$\text{Common log of } 1243 = \frac{.434294482}{.140345300} = 3.094\ 471\ 1. .$$

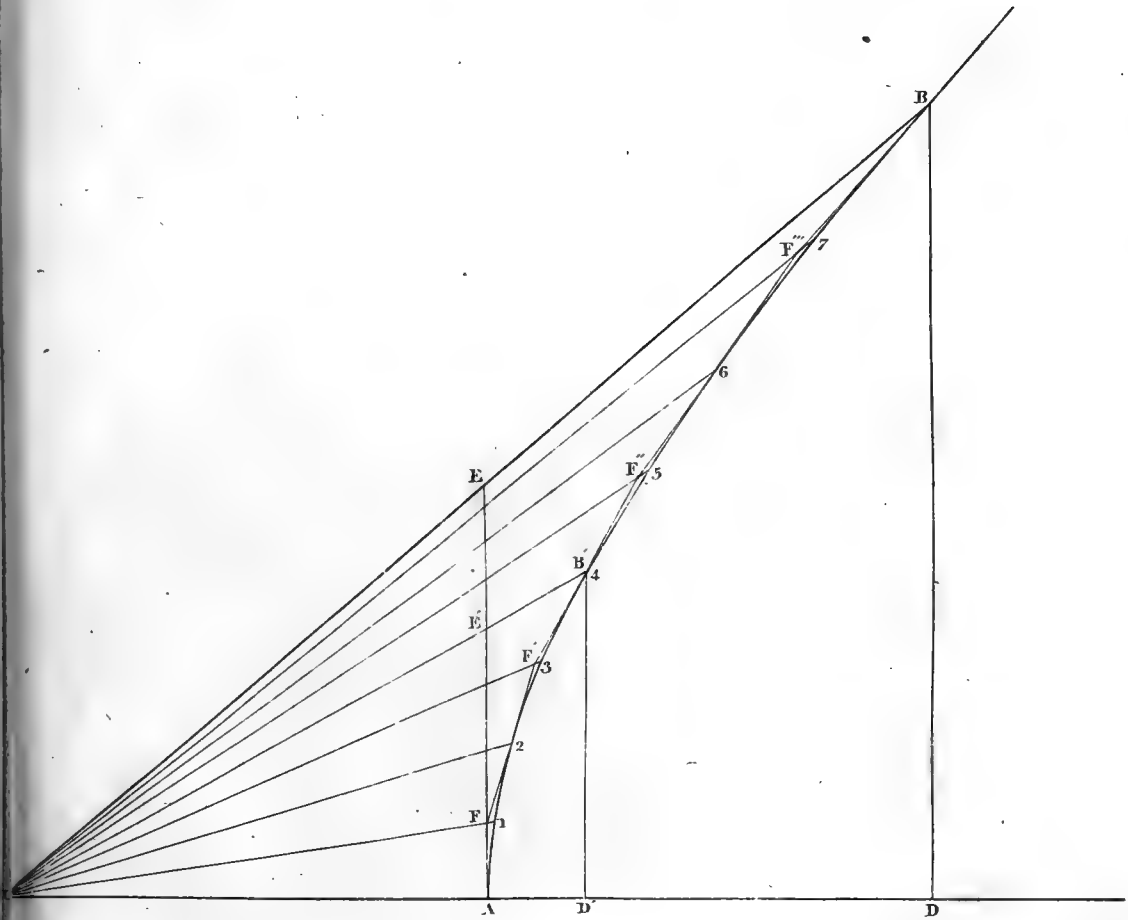

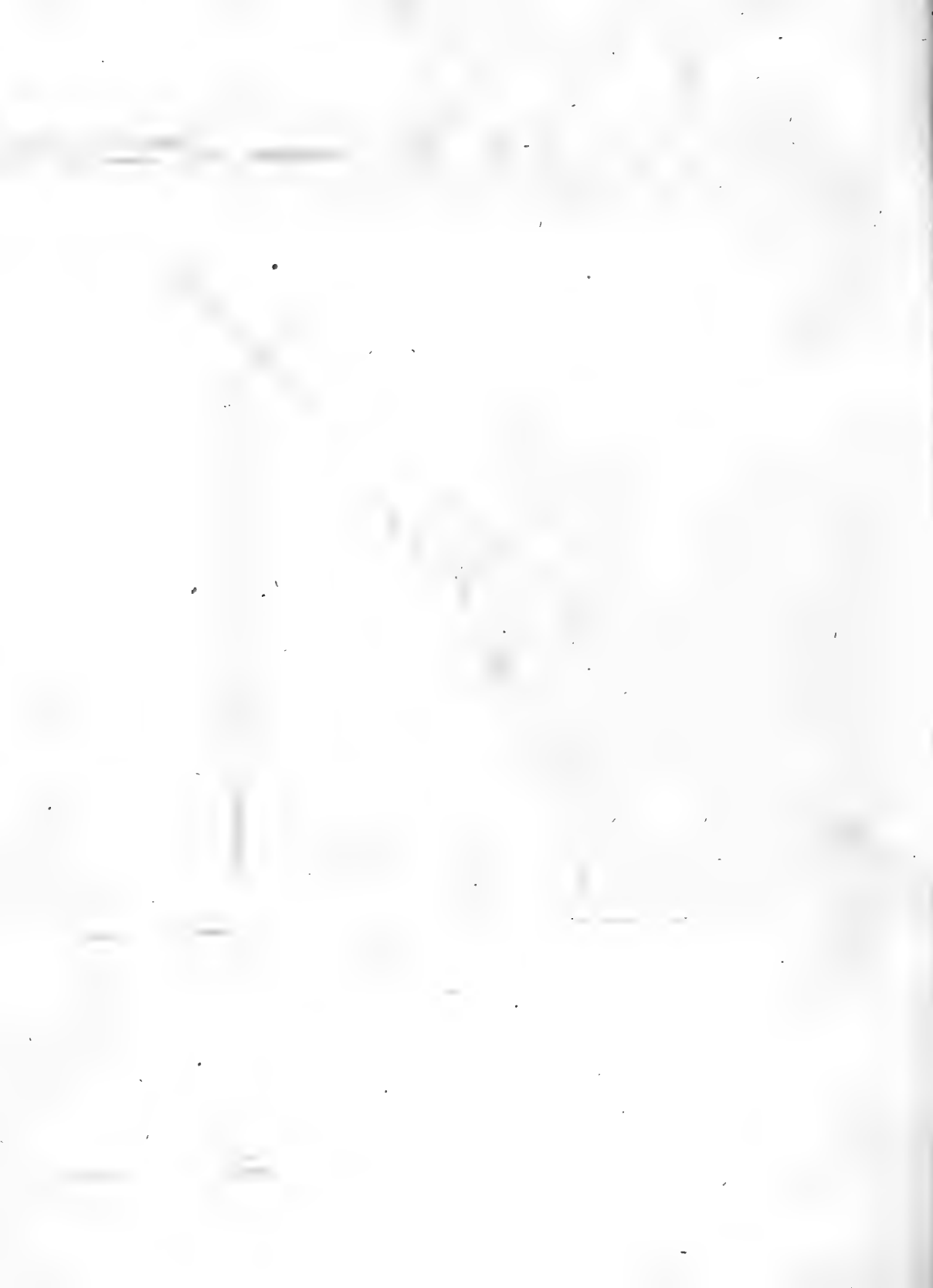

IX. REMARKS *on a* MINERAL *from* GREENLAND, *supposed*
to be CRYSTALLISED GADOLINITE. *By* THOMAS
ALLAN, ESQ. F. R. S. ED.

[*Read 21st November 1808*].

AMONG a parcel of minerals which I procured last spring, there are specimens of two very rare fossils; one of them, the Cryolite, the other I believe a variety of the Gadolinite. The former, is accurately described in the different mineralogical works, and I have little to add to the information contained in them. But the Gadolinite appears to be very imperfectly known, and has never yet been described as a crystallised fossil.

THE minerals in question were found on board a Danish prize, captured on her passage from Iceland to Copenhagen, and were sold with the rest of her cargo at Leith. On examination, I was surprised to find they corresponded so little with the fossils which are usually brought from that island, and consequently endeavoured to trace from the ship's papers, any particulars that might lead to the knowledge of their geographic origin. All I could learn was, that they were sent from Davis' Straits by a Missionary.

I CONSIDER this limited information, however, sufficient to fix on the coast of Greenland as the place from whence they had

had been brought; the only Cryolite known in Europe having been sent by a Missionary from Greenland to Copenhagen.

THE Gadolinite, from its extreme scarcity, is a mineral to be found in very few cabinets; and when this collection fell into my hands, was one of those I knew only by description. I was led to suspect that some of the minerals in this parcel belonged to that species, by observing, imbedded in a piece of granite, some small shapeless masses, whose external characters appeared to correspond entirely with those assigned to the gadolinite; but on reference to the mineralogical works which treat of this stone, I found more difficulty than could have been supposed in ascertaining whether they did so or not. The investigation, however, furnished a strong proof of the superiority of chemical test over external character; for although the shape, lustre, fracture, and geognostic relations, left me scarcely any room to doubt, yet on applying the blow-pipe and acids, it was quite evident, that the stone I first tried could not be gadolinite. I examined with great care the rest of the parcel, and picked out several, which, though very different, resembled in various respects the one that originally attracted attention; and with a view to satisfy myself, I sent duplicates to a friend in London, from whom I learnt, that one of those which I supposed to be gadolinite was certainly that mineral. Notwithstanding the very respectable authority I had obtained, to which I was inclined to pay the utmost deference, it was not till after minute and repeated investigations that I found myself disposed to submit to it; the physical characters of the specimen in question differed so very widely from those I was taught to expect.

It is more than twenty years since the gadolinite was first observed by M. ARRHENIUS, in an old quarry at Roslagie, near Ytterby in Sweden. It was described by Mr GEYER, and by him considered as a black zeolite.

IN 1794, M. GADOLIN analysed it, and found that it contained 38 *per cent.* of an unknown earth, whose properties approached to alumine in some respects, and to calcareous earth in others; but that it essentially differed from both, as well as from every other known earth.

IN 1797 M. EKEBERG repeated the analysis of M. GADOLIN, and obtained $47\frac{1}{2}$ *per cent.* of the new earth. This increase of quantity he attributed to the greater purity of the specimens he submitted to experiment, and in consequence of having confirmed the discovery of GADOLIN, he called the stone after him, and gave the name of Yttria to the earth.

ANALYSES by VAUQUELIN and KLAPROTH have since appeared. The quantity of yttria observed by the former amounted only to 35 *per cent.*; but the latter states $59\frac{3}{4}$ *per cent.*

THE small portions of this mineral, which, from its rarity, it is natural to conclude were at the disposal of these celebrated chemists, may in some measure account for the diversity of their results; but it is likewise by no means impossible, that the mineral itself may have varied in the proportions of its chemical ingredients.

THE difference which we find in the mineralogical descriptions of this fossil; hitherto only found in one spot, is much more difficult to account for. If the information I have otherwise obtained be correct, of which I have not the slightest doubt, we cannot help attributing a certain degree of carelessness to some of the authors, particularly the French writers, who have such opportunities at command*, of investigating every point relative to natural history. The great veneration

VOL. VI. P. II.

X x

they

* LUCAS notes the Gadolinite as one of the minerals in the collection at the *Jardin de Plantes.*

they entertain for the talents and accuracy of the celebrated HAÜY, may induce them to think his observations require no concurring testimony; and, on the other hand, the pupils of the German School, consider no mineral deserving a place in their system, till it has been examined and classed by their illustrious master, whose authority will be handed down by them with equal respect to posterity.

It is unnecessary to occupy the time of the Society, in giving a comparative view of the different descriptions of the Gadolinite. I shall only notice a few prominent features.

It is described by every one of the authors, as possessing a specific gravity of upwards of 4, and as acting powerfully upon the magnet. This last character is noticed by Professor JAMESON, in the first account he gives of the gadolinite; but in the second it is omitted, along with some others. KLAPROTH takes no notice of its magnetic power, but states the specific gravity at 4.237.

THE French writers describe the colour as black and reddish black. The German as raven or greenish black. These variations, with several others which may be observed on referring to the different authors, shew that some incorrectness must exist. But the most remarkable of all is, that the gadolinite, if *ever* magnetic, is not always so; for the specimens in the possession of the COUNT DE BOURNON are not, nor, as he informs me, are any that he has ever seen. It is therefore reasonable to conclude, that magnetism in the gadolinite may depend on accidental causes.

THE following is the description of the fossil, which I suppose to be that substance in a crystallised state; although nothing short of analysis can afford indisputable testimony of the identity of any mineral so little known.

SPECIFIC GRAVITY, 3.4802. The specimen weighed 1136.39 grains. Its surface is a little decomposed, and it has also some minute particles of felspar intermixed with it; both of which would affect the result in some degree; but neither were of such amount as to do so in any considerable degree.

HARDNESS: sufficient to resist steel, and scratch glass, but not quartz.

LUSTRE: shining, approaching to resinous.

FRACTURE: uneven, verging to flat conchoidal.

COLOUR: pitch black which I consider velvet black with a shade of brown; when pounded, of a greenish grey colour.

FIGURE: it occurs crystallised. The simplest figure, and perhaps the primitive form, is a rhomboidal prism, whose planes meet under angles of 120° and 60° . In some of the specimens, the acute angle is replaced by one face, in others by two, thereby forming six and eight sided prisms. All the specimens I possess are only fragments of crystals, none of which retain any part of a termination. They occur imbedded in felspar, probably granite.

CHEMICAL CHARACTERS: before the blow-pipe froths up, and melts but only partially, leaving a brown scoria; with borax it melts into a black glass. When pounded, and heated in diluted nitric acid, it tinges the liquid of a straw colour; and, some time after cooling, gelatinates.

THE principal distinguishing character of the gadolinite, is its forming a jelly with acid, a character belonging to few other minerals. The Mezotype Lazulite, Apophyllite, *Ædelite*, and Oxide of Zinc, so far as I know, alone possess the same quality; and it cannot easily be mistaken for any of them.

It has not the smallest attraction for the magnet; it does not decrepitate and disperse when exposed to the blow-pipe; it is not in any shape transparent.

THE Swedish fossil occurs in roundish amorphous masses, imbedded and disseminated in a granitic rock, having the external surfaces covered with a slight whitish coating, perhaps from the attachment of micaceous particles. There is no such appearance on the surface of the crystallised gadolinite.

THE situation which this mineral should hold in the system has been a matter of difficulty among mineralogists. HAÜY has placed it in the class of Earthy Fossils, immediately after his Anatase and Dioptase,—rather an unfortunate situation, both these having been recognised as ores of known metals, titanium and copper, since the publication of his admirable treatise.

WERNER, on account of its weight, has classed it among the metals; and from its natural alliances, and chemical composition, has given it a place among the irons*. If weight entitled it to be classed among the metals, several other minerals have an equal claim to the same situation. Of its natural alliances we know very little, farther than that the Swedish district where it is found abounds in iron; and as to its chemical composition, if $17\frac{1}{2}$ per cent. of iron be sufficient to counterbalance $59\frac{3}{4}$ ths of a new earth, it would be right to arrange it accordingly. The analyses of so many chemists of known celebrity, are certainly sufficient to justify the constitution of a new species for its reception. WERNER, however, may feel himself licensed in this arrangement, as he does not consider it necessary that a mineral compound shall preserve the characters of its components; but that any of the components may give to the composition characters sufficiently marked, to determine its relations. It is upon this distinction that he founds the difference between the predominant and characteristic principles †.

THE

* JAMESON, vol. ii. p. 613.

† BROCHANT, vol. i. p. 44.

THE arrangement of BRONGNIART appears much more judicious; he has placed it at the commencement of the Earthy Minerals, and assigns as a reason, that it is unique in its composition; and if placed in any other situation, it would interrupt the series, either in respect to its composition or external characters.

OF the Cryolite I have very little to observe, in addition to the descriptions given in the different mineralogical works. The specific gravity I found to be 2.961; HAÜY states it at 2.949. Among the various masses I examined, there was no trace of crystallization, farther than the cleavage, which is threefold, and nearly at right angles. The masses broke in two directions, (which may be supposed the sides of the prism), with great facility, leaving a very smooth surface; but the transverse cleavage was more difficult, and by no means so smooth. Several of the specimens being mixed with galena, pyrites, and crystals of sparry iron-ore, it would appear that the cryolite is a vein-stone; but I was not so fortunate as to find any of it attached to a rock specimen, so as to throw light on its geognostic relations.

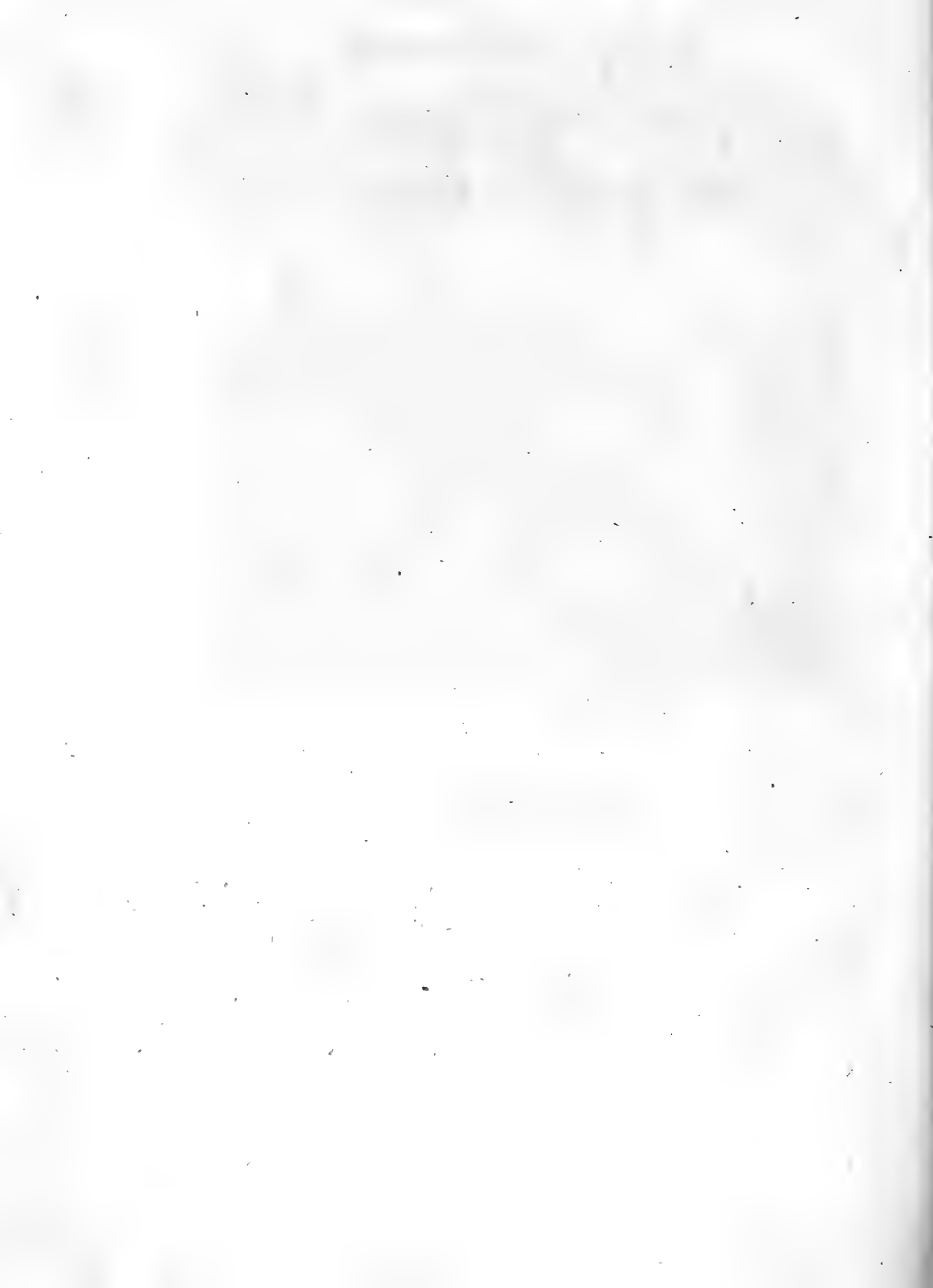



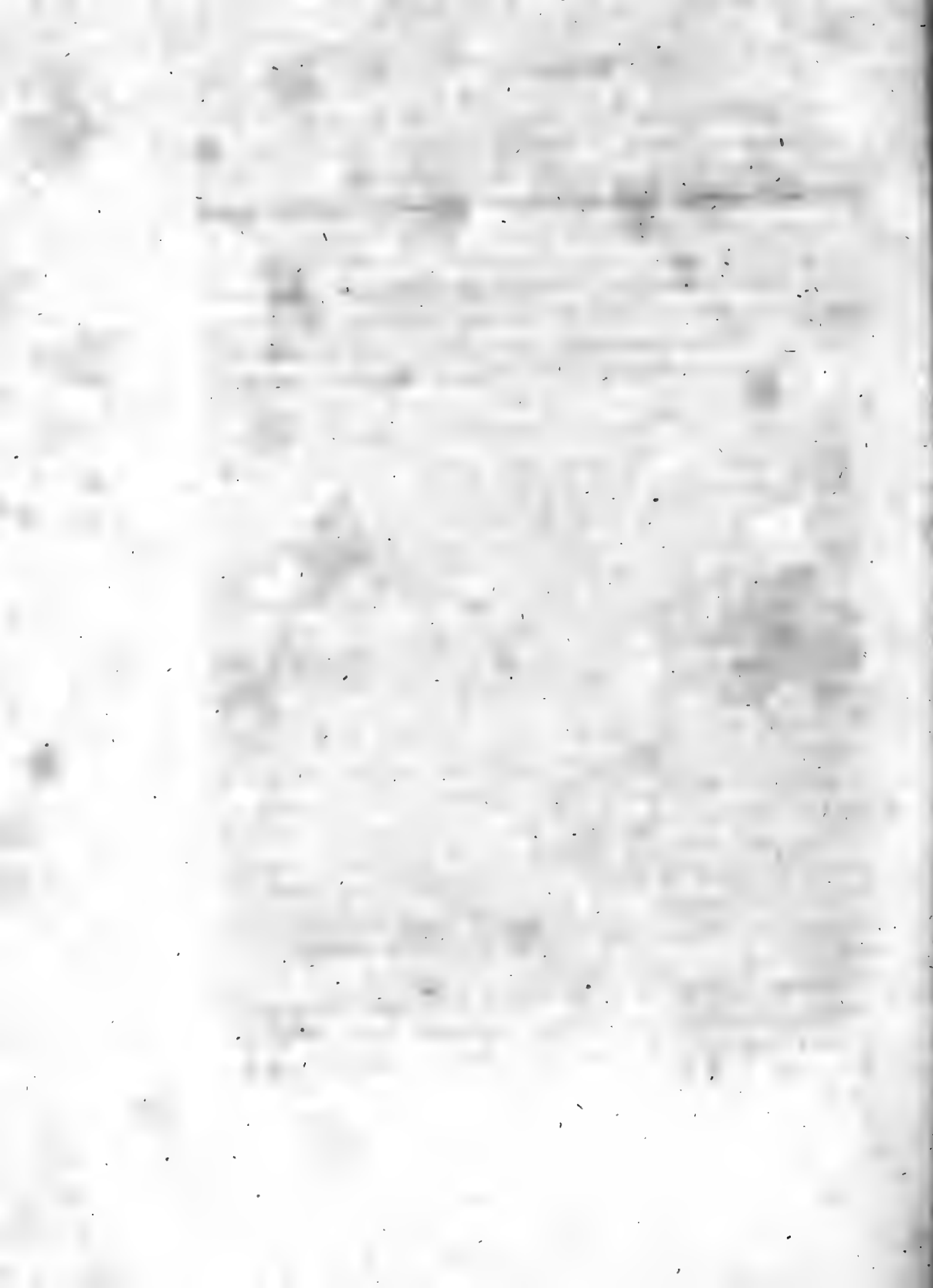

X. *On the Progress of Heat when communicated to Spherical Bodies from their Centres.* By JOHN PLAYFAIR, F. R. S. LOND. Sec. R. S. EDIN. and Professor of Natural Philosophy in the University of Edinburgh.

[Read March 6. 1809.]

I. **A**N argument against the hypothesis of central heat has been stated by an ingenious author as carrying with it the evidence of demonstration.

“ THE essential and characteristic property of the power
“ producing heat, is its tendency to exist every where in a state
“ of equilibrium, and it cannot hence be preserved without loss
“ or without diffusion, in an accumulated state. In the theory
“ of HUTTON, the existence of an intense local heat, acting for
“ a long period of time, is assumed. But it is impossible to pro-
“ cure caloric in an insulated state. Waving every objection
“ to its production, and supposing it to be generated to any ex-
“ tent, it cannot be continued, but must be propagated to the
“ contiguous matter. If a heat, therefore, existed in the cen-
“ tral region of the earth, it must be diffused over the whole
“ mass; nor can any arrangement effectually counteract this
“ diffusion. It may take place slowly, but it must always con-
“ tinue progressive, and must be utterly subversive of that sy-
“ stem of indefinitely renewed operations which is repre-
VOL. VI. P. II. Y y “ fented

“fented as the grand excellence of the Huttonian Theory *.”
 “Again, he observes, in giving what he says appears to him a demonstration of the fallacy of the first principles of the Huttonian System, “it will not be disputed, that the tendency of
 “caloric is to diffuse itself over matter, till a common temperature is established. Nor will it probably be denied, that a
 “power constantly diffusing itself from the centre of any mass
 “of matter, cannot remain for an indefinite time locally accumulated in that mass, but must at length become equal or
 “nearly so over the whole †.”

2. I must confess, notwithstanding the respect I entertain for the acuteness and accuracy of the author of this reasoning, that it does not appear to me to possess the force which he ascribes to it; nor to be consistent with many facts that fall every day under our observation. A fire soon heats a room to a certain degree, and though kept up ever so long, if its intensity, and all other circumstances remain the same, the heat continues very unequally distributed through the room; but the temperature of every part continues invariable. If a bar of iron has one end of it thrust into the fire, the other end will not in any length of time become red-hot; but the whole bar will quickly come into such a state, that every point will have a fixed temperature, lower as it is farther from the fire, but remaining invariable while the condition of the fire, and of the medium that surrounds the bar, continues the same. The reason indeed is plain: the equilibrium of heat is not so much a primary law in the distribution of that fluid, as the limitation of another law which is general and ultimate, consisting in the tendency of heat to pass with a greater or a less velocity, according to circumstances, from bodies where the temperature is

* MURRAY'S *System of Chemistry*, vol. iii. Appendix, p. 49.

† Page 51.

is higher, to those where it is lower, or from those which contain more heat, according to the indication of the thermometer, to those which contain less. It is of this general tendency, that the equilibrium or uniform distribution of heat is a consequence,—but a consequence only contingent, requiring the presence of another condition, which may be wanting, and actually is wanting, in many instances. This condition is no other, than that the quantity of heat in the system should be given, and should not admit of continual increase from one quarter, nor diminution from another. When such increase and diminution take place, what is usually called “the equilibrium of heat” no longer exists. Thus, if we expose a thermometer to the sun’s rays, it immediately rises, and continues to stand above the temperature of the surrounding air. The way in which this happens is perfectly understood: the mercury in the thermometer receives more heat from the solar rays than the air does; it begins therefore to rise as soon as those rays fall on it; at the same time, it gives out a portion of its heat to the air, and always the more, the higher it rises. It continues to rise, therefore, till the heat which it gives out every instant to the air, be equal to that which it receives every instant from the solar rays. When this happens, its temperature becomes stationary; the momentary increment and decrement of the heat are the same, and the total, of course, continues constant. The thermometer, therefore, in such circumstances, never acquires the temperature of the surrounding air; and the only equilibrium of the heat, is that which subsists between the increments and the decrements just mentioned: these indeed are, strictly speaking, *in equilibrio*, as they accurately balance one another. This species of equilibrium, however, is quite different from what is implied in the uniform diffusion of heat.

3. IN order to state the argument more generally, let A, B, C, D, &c. be a series of contiguous bodies; or let them be parts of the same body; and let us suppose that A receives, from some cause, into the nature of which we are not here to inquire, a constant and uniform supply of heat. It is plain, that heat will flow continually from A to B, from B to C, &c.; and in order that this may take place, A must be hotter than B, B than C, and so on; so that no uniform distribution of heat can ever take place. The state, however, to which the system will tend, and at which, after a certain time, it must arrive, is one in which the momentary increase of the heat of each body is just equal to its momentary decrease; so that the temperature of each individual body becomes fixed, all these temperatures together forming a series decreasing from A downwards. To be convinced that this is the state which the system must assume, suppose any body D, by some means or other, to get more heat than that which is required to make the portion of heat which it receives every moment from C, just equal to that which it gives out every moment to E; as its excess of temperature above E is increased, it will give out more heat to E, and as the excess of the temperature of C above that of D is diminished, D will receive less heat from C; therefore, for both reasons, D must become colder, and there will be no stop to the reduction of its temperature, till the increments and decrements become equal as before.

4. IF, therefore, heat be communicated to a solid mass, like the earth, from some source or reservoir in its interior, it must go off from the centre on all sides, toward the circumference. On arriving at the circumference, if it were hindered from proceeding farther; and if space or vacuity presented to heat an impenetrable barrier, then an accumulation of it at the surface, and at last a uniform distribution of it through the whole mass, would inevitably be the consequence. But if
heat

heat may be lost and dissipated in the boundless fields of vacuity, or of ether, which surround the earth, no such equilibrium can be established. The temperature of the earth will then continue to augment only, till the heat which issues from it every moment into the surrounding medium, become equal to the increase which it receives every moment from the supposed central reservoir. When this happens, the temperature at the superficies can undergo no farther change, and a similar effect must take place with respect to every one of the spherical and concentric strata into which we may conceive the solid mass of the globe to be divided. Each of these must in time come to a temperature, at which it will give out as much heat to the contiguous stratum on the outside, as it receives from the contiguous stratum on the inside; and, when this happens, its temperature will remain invariable.

5. THAT we may trace this progress with more accuracy, let us suppose a spherical body to be heated from a source of heat at its centre; and let b, b', b'' , be the temperatures at the surfaces of two contiguous and concentric strata, the distances from the centre being x, x', x'' ; and let it also be supposed, that the thickness of each of the strata, to wit, $x' - x$, and $x'' - x'$, is very small.

THEN supposing the body to be homogeneous, the quantity of heat that flows from the inner stratum into the outward, in a given time, will be proportional to the excess of its temperature above that of the outward stratum multiplied into its quantity of matter, that is, to $(b - b')(x'^3 - x^3)$.

6. IN

6. IN the same manner, the heat which goes off from the second stratum in the same time, is proportional to $(b' - b'')$ $(x''^3 - x'^3)$; and these two quantities, when the temperature of the second stratum becomes constant, must be equal to one another, or $(b - b') (x'^3 - x^3) = (b' - b'') (x''^3 - x'^3)$.

BUT because $b - b'$, and $x' - x$ are indefinitely small, $b - b' = \dot{b}$, and $x'^3 - x^3 = 3x^2 \dot{x}$; therefore $\dot{b} \times 3x^2 \dot{x} =$ a given quantity; which quantity, since \dot{x} is given, we may represent by $a^2 \dot{x}^2$; so that $\dot{b} = \frac{a^2 \dot{x}^2}{3x^2 \dot{x}} = \frac{a^2 \dot{x}}{3x^2}$, or, because \dot{b} is negative in respect of \dot{x} , being a decrement, while the latter is an increment, $\dot{b} = -\frac{a^2 \dot{x}}{3x^2}$, and therefore $b = C + \frac{a^2}{3x}$.

7. To determine the constant quantity C , let us suppose that the temperature at the surface of the internal *nucleus* of ignited matter is $= H$, and $r =$ radius of that nucleus. Then, in the particular case, when $x = r$ and $b = H$, the preceding equation gives $H = C + \frac{a^2}{3r}$; so that $C = H - \frac{a^2}{3r}$, and consequently $b = H - \frac{a^2}{3r} + \frac{a^2}{3x}$; or $b = H + \frac{a^2}{3} \left(\frac{1}{x} - \frac{1}{r} \right)$.

8. IT is evident, from this formula, that for every value of x there is a determinate value of b , or that for every distance from the centre there is a fixed temperature, which, after a certain time, must be acquired, and will remain invariable as long

long as the intensity and magnitude of the central fire continue the same.

9. It remains for us to determine the value of a^2 , which, though constant, is not yet given, or known from observation.

At the surface of the globe we may suppose the mean temperature to be known: let T be that temperature, and let $R =$ the radius of the globe. Then, when $x = R$, $b = T$, and by

substituting in the general formula, we have $T = H + \frac{a^2}{3} \left(\frac{1}{R} - \frac{1}{r} \right)$,

$$\text{and } a^2 = \frac{3(T - H)}{\frac{1}{R} - \frac{1}{r}} = \frac{3Rr(H - T)}{R - r}.$$

$$\text{THUS } b = H + \frac{Rr(H - T)}{R - r} \left(\frac{1}{x} - \frac{1}{r} \right)$$

$$= H - \frac{Rr(H - T)}{R - r} \left(\frac{1}{r} - \frac{1}{x} \right).$$

HENCE also by reduction

$$b = \frac{RT - rH}{R - r} + \frac{Rr(H - T)}{x(R - r)},$$

$$\text{or } b = \frac{1}{R - r} (RT - rH) + \frac{Rr(H - T)}{x}.$$

FROM this equation, it is evident, that $b = \frac{RT - rH}{R - r}$, or

the excess of the temperature at any distance x from the centre, above a certain given temperature, is inversely as x . But the construction of the hyperbola which is the locus of the preceding

preceding equation, will exhibit the relation between the temperature and the distance, in the way of all others least subject to misapprehension.

LET the circle (Plate X. fig. 3.) described with the radius AB , represent the globe of the earth; and the circle described with the radius AH an ignited mass at the centre. Let HK , perpendicular to AB , be the temperature at H , the surface of the ignited mass; and let FD be the temperature at any point whatever, in the interior of the earth, BM representing that at the surface. Then AB being $= R$ in the preceding equation, $AH = r$, $HK = H$, $BM = T$; $AF = x$, and $FD = b$, these two last being variable quantities; since

$$\left(b - \frac{RT - rH}{R - r}\right)x = \frac{Rr(H - T)}{R - r} \text{ we have, (taking } AE$$

$$= \frac{RT - rH}{R - r}, \text{ and drawing } EL \text{ parallel to } AB, \text{ meeting } HK$$

in N , and FD in O .) $OD \times OE = \frac{BA \cdot AH(HK - BM)}{BH}$, which is a given quantity.

THEREFORE D is in a rectangular hyperbola, of which the centre is E , the asymptotes EG and EL , and the rectangle of the coordinates, equal to $BA \cdot AH \times \frac{HK - BM}{BH}$, or, which amounts to the same, to $KN \cdot NE$.

IT is evident from this, that if the sphere were indefinitely extended, the temperature at the point B and all other things remaining the same, the temperature at its superficies would not be less than AE , or than the quantity $\frac{RT - rH}{R - r}$.

THE quantity AE , or $\frac{RT - rH}{R - r}$, is supposed here to be subtracted; if RT be less than rH , it will change its sign, and must be taken on the other side of the centre A .

10. THE results of these deductions may be easily represented numerically, and reduced into tables, for any particular values that may be assigned to the constant quantities. Thus, if the radius of the globe, or $R = 100$, that of the ignited nucleus or $r = 1$; the temperature of the nucleus, or $H = 1000$, and T the temperature at the surface $= 60$, the formula becomes

$$b = 50.505 + \frac{949.494}{x}$$

Values of x	Values of b
10	145°.454
20	98.423
30	82.599
40	74.686
50	69.938
60	66.330
70	63.926
80	62.361
90	61.055
100	60.

11. OTHER things remaining as before, if we now make

$$r = 10, \text{ then } b = -44.444 + \frac{10444}{x}$$

x	b
20	477°.556
30	303.556
40	226.556
50	164.556
60	145.556
70	104.556
80	85.056
90	64.556
100	60.000

12. IF $R = 10$, $r = 1$, $H = 10000$, and $T = 60$,

$$b = -1044.44 + \frac{11044.44}{x}$$

Values of x	Values of b
1	10000°.00
2	4477.70
3	2637.04
4	1716.67
5	1164.44
6	796.30
7	533.33
8	346.16
9	182.72
10	60.00

13. THE

13. 1. THE general conclusions which result from all this are, that when we suppose an ignited nucleus of a given magnitude, and a given intensity of heat, there is in the sphere to which it communicates heat a fixed temperature for each particular stratum, or for each spherical shell, at a given distance from the centre; and that a great intensity of heat in the interior, is compatible with a very moderate temperature at the surface.

2. HOWEVER great the sphere may be, the heat at its surface cannot be less than a given quantity; R, r, H and T remaining the same. It must be observed, that though R is put for the radius of the globe; it signifies in fact nothing, but the distance at which the temperature is T , as r does the distance at which the temperature is H .

THEREFORE were the sphere indefinitely extended, the temperature at its superficies would not be less than the quantity

$\frac{RT - rH}{R - r}$, that is, not less than 50.5 in the first of the preceding examples, than — 44.4 in the second, or — 1044.4 in the third.

14. IN all this the sphere is supposed homogeneous; but if it be otherwise, and vary in density, in the capacity of the parts for heat, or in their power to conduct heat, providing it do so as any function of the distance from the centre, the calculus may be instituted as above. For example, let the den-

ty be supposed to vary as $\frac{b}{b+x}$, then we have as before

$(b - b')(x'^3 - x^3) \frac{b}{b+x}$ for the momentary increment of

heat in a stratum placed at the distance x from the centre,

Zz 2

or

or $\dot{b} \times 3x \dot{x} \times \frac{b}{b+x} =$ to a given quantity, or to $a^2 \dot{x}^2$, and

therefore $\dot{b} = -\frac{a^2(b+x)\dot{x}}{3bx^2} = -\frac{a^2\dot{x}}{3x^2} - \frac{a^2\dot{x}}{bx}$. Hence $b =$

$C + \frac{a^2}{3x} - \frac{a^2}{b} \text{Log } x$. Suppose that when $x = r$, the radius of the heated nucleus, $b = H$; then $H =$

$$C + \frac{a^2}{3r} - \frac{a^2}{b} \text{Log } r; \text{ and } C =$$

$$H - \frac{a^2}{3r} + \frac{a^2}{b} \text{Log } r; \text{ therefore } b =$$

$$H - \frac{a^2}{3r} + \frac{a^2}{3x} + \frac{a^2}{b} \text{Log } \frac{r}{x}.$$

In this expression a^2 will be determined, if the temperature at any other distance R from the centre is known. Let this be T ; then by substitution we have

$$T = H - \frac{a^2}{3r} + \frac{a^2}{3R} + \frac{a^2}{b} \text{Log } \frac{r}{R},$$

$$\text{and } a^2 = \frac{T - H}{\frac{1}{3R} - \frac{1}{3r} + \frac{1}{b} \text{Log } \frac{r}{R}}.$$

$$\text{Hence } b = H + \left(\frac{T - H}{\frac{1}{3R} - \frac{1}{3r} + \frac{1}{b} \text{Log } \frac{r}{R}} \right) \times$$

$$\left(-\frac{1}{3r} + \frac{1}{3x} + \frac{1}{b} \text{Log } \frac{r}{x} \right).$$

15. THIS is given merely as an example of the method of conducting the calculus when the variation of the density is taken into account, and not because there is reason to believe that the law which that variation actually follows, is the same that has now been hypothetically assumed.

16. THE principle on which we have proceeded, applies not only to solids, such as we suppose the interior of the earth, but it applies also to fluids like the atmosphere, provided they are supposed to have reached a steady temperature. The propagation of heat through fluids is indeed carried on by a law very different from that which takes place with respect to solids; it is not by the motion of heat, but by the motion of the parts of the fluid itself. Yet, when we are seeking only the mean result, we may suppose the heat to be so diffused, that it does not accumulate in any particular stratum, but is limited by the equality of the momentary increments and decrements of temperature which that stratum receives. This is conformable to experience; for we know that a constancy, not of temperature, but of difference between the temperature of each point in the atmosphere and on the surface, actually takes place. Thus, near the surface, an elevation of 280 feet produces, in this country, a diminution of one degree. The strata of our atmosphere, however, differ in their capacity of heat, or in the quantity of heat contained in a given space, at a given temperature. Concerning the law which the change of capacity follows, we have no certain information to guide us; and we have no resource, therefore, but to assume a hypothetical law, agreeing with such facts as are known, and, after deducing the results of this law, to compare them with the observations made on the temperature of the air, at different heights above the surface of the earth.

17. LET us then suppose, that the strata of the atmosphere have a capacity for heat, which increases as the air becomes rarer, so as to be proportional to mb^{-x} , x denoting, as before, the distance from the centre of the earth, r the radius of the earth, m and b determinate, but unknown quantities, such that mb^{-1} or $\frac{m}{b}$, expresses the capacity of air for heat, when of its ordinary density, at the surface of the earth. The formula thus assumed, agrees with the extreme cases; for, when $x = r$, the capacity of heat = $\frac{m}{b}$, a finite quantity; when x increases, $\frac{r}{x}$ diminishes, and so also does $\frac{r}{b^x}$, if b is greater than unity, and therefore $\frac{m}{r b^x}$ increases continually. It does not, however, increase beyond a certain limit, for when x is infinite $\frac{m}{r b^x}$ becomes $\frac{m}{r}$, or m .

18. HENCE,

18. HENCE, by reasoning as in § 6. the momentary increment of the temperature, or sensible heat, of any stratum, is as

$$-\frac{a^2 \dot{x}}{3x^2} \text{ directly, and its capacity for heat, or } mb^{-\frac{r}{x}} \text{ inversely,}$$

$$\text{that is, } \dot{b} = -\frac{a^2 \dot{x}}{3x^2} \times \frac{r}{m} = -\frac{a^2 b^{\frac{r}{x}} \dot{x}}{3mx^2}.$$

$$\text{LET } \frac{r}{x} = y, \text{ then } -\frac{r \dot{x}}{x^2} = \dot{y}, \text{ so that } -\frac{a^2 \dot{x}}{3mx^2} = \frac{a^2 \dot{y}}{3mr}, \text{ and}$$

$$\text{therefore } \dot{b} = \frac{a^2 b^y}{3mr} \dot{y}. \text{ Hence } b = C + \frac{a^2}{3mr \text{Log} b} b^y =$$

$$C + \frac{a^2}{3mr \text{Log} b} b^{\frac{r}{x}}.$$

19. To determine C, if T be the temperature of the air at the surface, when $x=r$, $T = C + \frac{a^2 b}{3mr \text{Log} b}$, and $C =$

$$T - \frac{a^2 b}{3mr \text{Log} b}.$$

$$\text{HENCE } b = T - \frac{a^2 b}{3mr \text{Log} b} + \frac{a^2 b^{\frac{r}{x}}}{3mr \text{Log} b} =$$

$$T - \frac{a^2 (b - b^{\frac{r}{x}})}{3mr \text{Log} b}.$$

THIS formula, when $x=r$ gives $b=T$, and when x is infinite, it gives $b = T - \frac{a^2 (b-1)}{3mr \text{Log} b}$. In all intermediate

cases,

cases, as x is greater than r , $b^{\frac{r}{x}}$ is less than b , (b being a number greater than 1) and therefore $b - b^{\frac{r}{x}}$ is positive, so that b is less than T , as it ought to be.

20. WE may obtain an approximate value of this formula, without exponential quantities, that will apply to all the cases in which x and r differ but little in respect of r , that is, in all the cases to which our observations on the atmosphere can possibly extend.

IF, in the term $b^{\frac{r}{x}}$ we write $r + z$ for x , z being the height of any stratum of air above the surface of the earth, we have $b^{\frac{r}{x}} = b^{\frac{r}{r+z}}$.

21. BUT, from the nature of exponentials, we know $b^{\frac{r}{x}} =$
 $1 + \frac{r}{x} \text{Log } b + \frac{r^2 (\text{Log } b)^2}{2 x^2} + \frac{r^3 (\text{Log } b)^3}{2 \cdot 3 x^3}, \text{ \&c.} =$
 $1 + \frac{r}{r+z} \text{Log } b + \frac{r^2 (\text{Log } b)^2}{2 (r+z)^2} +, \text{ \&c.}$

Now $\frac{r}{r+z} = 1 - \frac{z}{r} + \frac{z^2}{r^2} -, \text{ \&c.}$ And if we leave out the higher powers of z , we have nearly

$$\frac{r}{r+z}$$

$$\frac{r}{r+z} = 1 - \frac{z}{r}$$

$$\frac{r^2}{(r+z)^2} = 1 - \frac{2z}{r}$$

$$\frac{r^3}{(r+z)^3} = 1 - \frac{3z}{r}, \text{ \&c.}$$

THEREFORE, by substitution, we have $b^{\frac{r}{r+z}} =$

$$1 + \left(1 - \frac{z}{r}\right) \text{Log } b + \left(1 - \frac{2z}{r}\right) \frac{(\text{Log } b)^2}{2} +, \text{ \&c.} =$$

$$\left\{ \begin{array}{l} 1 + \text{Log } b + \frac{(\text{Log } b)^2}{2} + \frac{(\text{Log } b)^3}{2 \cdot 3} +, \text{ \&c.} \\ - \frac{z}{r} \text{Log } b - \frac{z}{r} (\text{Log } b)^2 - \frac{z}{r} \frac{(\text{Log } b)^3}{2}, \text{ \&c.} \end{array} \right\}$$

Now, from the nature of exponentials,

$$b = 1 + \text{Log } b + \frac{\text{Log } b^2}{2} + \frac{\text{Log } b^3}{2 \cdot 3} +, \text{ \&c.}$$

$$\text{And } \frac{z}{r} \text{Log } b + \frac{z}{r} (\text{Log } b)^2 + \frac{z}{r} \frac{(\text{Log } b)^3}{2}, \text{ \&c.}$$

$$= \frac{z}{r} \text{Log } b \left(1 + \text{Log } b + \frac{(\text{Log } b)^2}{2} +, \text{ \&c.} \right) =$$

$$\frac{z}{r} b \text{Log } b; \text{ therefore when } z \text{ is very small, } b^{\frac{r}{r+z}} =$$

$$b - \frac{z b}{r} \text{Log } b, \text{ and therefore (\S 19.), } a^2 \frac{(b - b^{\frac{r}{r+z}})}{3 m r \text{Log } b} =$$

$$a^2 \frac{\left(b - b + \frac{b z \text{Log } b}{r}\right)}{3 m r \text{Log } b} = \frac{a^2 b z}{3 m r^2}; \text{ hence when } z \text{ is very}$$

$$\text{small, } b = T - \frac{a^2 b z}{3 m r^2}.$$

22. THEREFORE when z , or the height above the surface is small, b diminishes in the same proportion that the height increases, which is conformable to experience.

IN our climate, when $z = 280$ feet, $\frac{a^2 b \times 280}{3 m r^2} = 1^\circ$; fo

that the co-efficient $\frac{a^2 b}{3 m r^2} = \frac{1}{280}$, and therefore

$$b = T - \frac{z}{280}.$$

WHEN the constant quantities are thus determined, the formula agrees nearly with observation. In the rule for barometrical measurements, it is implied, that the heat of the atmosphere decreases uniformly; but the rate for each particular case is determined by actual observation, or by thermometers observed at the top and bottom of the height to be measured.

XI. *Experiments on Allanite, a new Mineral from Greenland.* By THOMAS THOMSON, M. D. F. R. S. E. Fellow of the Imperial Chirurgo-Medical Academy of Petersburg.

[Read Nov. 5. 1810.]

ABOUT three years ago, a Danish vessel * was brought into Leith as a prize. Among other articles, she contained a small collection of minerals, which were purchased by THOMAS ALLAN, Esq; and Colonel IMRIE, both members of this Society. The country from which these minerals had been brought was not known for certain; but as the collection abounded in Cryolite, it was conjectured, with very considerable probability, that they had been collected in Greenland.

AMONG the remarkable minerals in this collection, there was one, which, from its correspondence with Gadolinite, as described in the different mineralogical works, particularly attracted the attention of Mr ALLAN. Confirmed in the idea of its being a variety of that mineral, by the opinion of Count BOURNON, added to some experiments made by Dr WOLLASTON, he was induced to give the description which has since been published in a preceding part of the present volume.

ABOUT a year ago, Mr ALLAN, who has greatly distinguished himself by his ardent zeal for the progress of mineralogy in all

A 2

its

* DER FRUHLING, Captain JACOB KETELSON, captured, on her passage from Iceland to Copenhagen.

its branches, favoured me with some specimens of this curious mineral, and requested me to examine its composition,—a request which I agreed to with pleasure, because I expected to obtain from it a quantity of *yttria*, an earth which I had been long anxious to examine, but had not been able to procure a sufficient quantity of the Swedish Gadolinite for my purpose. The object of this paper, is to communicate the result of my experiments to the Royal Society,—experiments which cannot appear with such propriety any where as in their Transactions, as they already contain a paper by Mr ALLAN on the mineral in question.

I. DESCRIPTION.

I AM fortunately enabled to give a fuller and more accurate description of this mineral than that which formerly appeared, Mr ALLAN having, since that time, discovered an additional quantity of it, among which, he not only found fresher and better characterised fragments, but also some entire crystals. In its composition, it approaches most nearly to Cerite, but it differs from it so much in its external characters, that it must be considered as a distinct species. I have therefore taken the liberty to give it the name of *Allanite*, in honour of Mr ALLAN, to whom we are in reality indebted for the discovery of its peculiar nature.

ALLANITE occurs massive and disseminated, in irregular masses, mixed with black mica and felspar; also crystallised; the varieties observed are,

1. A four-sided oblique prism, measuring 117° and 63° .
2. A six-sided prism, acuminated with pyramids of four sides, set on the two adjoining opposite planes. These last are so minute as to be incapable of measurement. But, as nearly as the eye can determine, the form resembles *Fig. 1.*; the prism of which has two right angles, and four measuring 135° .

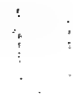

3. A flat prism, with the acute angle of 63° replaced by one plane, and terminated by an acumination, having three principal facettes set on the larger lateral planes, with which the centre one measures 125° and 55° . Of this specimen, an engraving is given in the annexed Plate, *Fig. 2.*

SPECIFIC gravity, according to my experiments, 3.533. The specimen appears to be nearly, though not absolutely, pure. This substance, however, is so very much mixed with mica, that no reliance can be placed on any of the trials which have been made. Count BOURNON, surpris'd at the low specific gravity noted by Mr ALLAN, which was 3.480, broke down one of the specimens which had been sent him, in order to procure the substance in the purest state possible, and the result of four experiments was as follows,

4.001

3.797

3.654

3.119

In a subsequent experiment of Mr ALLAN's, he found it 3.665. From these it appears, that the substance is not in a pure state. Its colour is so entirely the same with the mica, with which it is accompanied, that it is only by mechanical attrition that they can be separated.

COLOUR, brownish-black.

EXTERNAL lustre, dull ; internal, shining and resinous, slightly inclining to metallic.

FRACTURE, small conchoidal.

FRAGMENTS, indeterminate, sharp-edged.

OPAKE.

SEMI-HARD in a high degree. Does not scratch quartz nor felspar, but scratches hornblende and crown-glass.

BRITTLE.

EASILY

EASILY frangible.

POWDER, dark greenish-grey.

BEFORE the blow-pipe it froths, and melts imperfectly into a brown scoria.

GELATINISES in nitric acid. In a strong red heat it loses 3.98 per cent. of its weight.

II. EXPERIMENTS TO ASCERTAIN ITS COMPOSITION.

My first experiments were made, on the supposition that the mineral was a variety of gadolinite, and were pretty much in the style of those previously made on that substance by EKEBERG, KLAPROTH, and VAUQUELIN.

1. 100 grains of the mineral, previously reduced to a fine powder in an agate mortar, were digested repeatedly on a sand bath in muriatic acid, till the liquid ceased to have any action on it. The undissolved residue was silica, mixed with some fragments of mica. When heated to redness, it weighed 33.4 grains.

2. THE muriatic acid solution was evaporated almost to dryness, to get rid of the excess of acid, dissolved in a large quantity of water, mixed with a considerable excess of carbonate of ammonia, and boiled for a few minutes. By this treatment, the whole contents of the mineral were precipitated in the state of a yellowish powder, which was separated by the filtre, and boiled, while still moist, in potash-ley. A small portion of it only was dissolved. The potash-ley was separated from the undissolved portion by the filtre, and mixed with a solution of sal ammoniac, by means of which a white powder precipitated from it. This white matter being heated to redness, weighed 7.9 grains. It was digested in sulphuric acid, but 3.76 grains refused to dissolve. This portion possessed the properties of silica. The dissolved portion being mixed with a few drops of sulphate

fulphate of potash, shot into crystals of alum. It was therefore alumina, and amounted to 4.14 grains.

3. THE yellow matter which refused to dissolve in the potash-ley, was mixed with nitric acid. An effervescence took place, but the liquid remained muddy, till it was exposed to heat, when a clear reddish-brown solution was effected. This solution was evaporated to dryness, and kept for a few minutes in the temperature of about 400° , to peroxidize the iron, and render it insoluble. A sufficient quantity of water was then poured on it, and digested on it for half-an-hour, on the sand-bath. The whole was then thrown upon a filtre. The dark red matter which remained on the filtre, was drenched in oil, and heated to redness, in a covered crucible. It was then black, and attracted by the magnet; but had not exactly the appearance of oxide of iron. It weighed 42.4 grains.

4. THE liquid which passed through the filtre, had not the sweet taste which I expected, but a slightly bitter one, similar to a weak solution of nitrate of lime. Hence it was clear, that no yttria was present, as there ought to have been, had the mineral contained that earth. This liquid being mixed with carbonate of ammonia, a white powder precipitated, which, after being dried in a red heat, weighed 17 grains. It dissolved in acids with effervescence; the solution was precipitated white by oxalate of ammonia, but not by pure ammonia. When dissolved in sulphuric acid, and evaporated to dryness, a light white matter remained, tasteless, and hardly soluble in water. These properties indicate carbonate of lime. Now, 17 grains of carbonate of lime are equivalent to about 9.23 grains of lime.

5. FROM

5. From the preceding analysis, supposing it accurate, it followed, that the mineral was composed of

Silica,	-	-	-	37.16
Lime,	-	-	-	9.23
Alumina,	-	-	-	4.14
Oxide of iron,	-	-	-	42.40
Volatile matter,	-	-	-	3.98
				<hr/>
				96.91
Loss,	-	-	-	3.09
				<hr/>
				100.00

But the appearance of the supposed oxide of iron, induced me to suspect, that it did not consist wholly of that metal. I thought it even conceivable, that the yttria which the mineral contained, might have been rendered insoluble by the application of too much heat, and might have been concealed by the iron with which it was mixed. A number of experiments, which it is needless to specify, soon convinced me, that, besides iron, there was likewise another substance present, which possessed properties different from any that I had been in the habit of examining. It possessed one property at least in common with yttria; its solution in acids had a sweet taste; but few of its other properties had any resemblance to those which the chemists to whom we are indebted for our knowledge of yttria, have particularised. But as I had never myself made any experiments on yttria, I was rather at a loss what conclusion to draw. From this uncertainty, I was relieved by Mr ALLAN, who had the goodness to give me a small fragment of gadolinite, which had been received directly from Mr EKEBERG. From this I extracted about 10 grains of yttria; and upon comparing its properties with those of the substance in question, I found

found them quite different. Convinced by these experiments, that the mineral contained no yttria, but that one of its constituents was a substance with which I was still unacquainted, I had recourse to the following mode of analysis, in order to obtain this substance in a pure state.

III. ANALYSIS OF ALLANITE.

1. 100 grains of the mineral, previously reduced to a fine powder, were digested in hot nitric acid till nothing more could be dissolved. The undissolved residue, which was silica, mixed with some scales of mica, weighed, after being heated to redness, 35.4 grains.

2. THE nitric acid solution was transparent, and of a light-brown colour. When strongly concentrated by evaporation, to get rid of the excess of acid, and set aside in an open capsule, it concreted into a whitish solid matter, consisting chiefly of soft crystals, nearly colourless, having only a slight tinge of yellow. These crystals being left exposed to the air, became gradually moist, but did not speedily deliquesce. The whole was therefore dissolved in water, and the excess of acid, which was still present, carefully neutralised with ammonia. By this treatment, the solution acquired a much deeper brown colour; but still continued transparent. Succinate of ammonia was then dropped in with caution. A copious reddish-brown precipitate fell, which being washed, dried, and heated to redness in a covered crucible, weighed 25.4 grains. It possessed all the characters of black oxide of iron. For it was attracted by the magnet, completely soluble in muriatic acid, and the solution was not precipitated by oxalate of ammonia.

3. THE liquid being still of a brown colour, I conceived it not to be completely free from iron. On this account, an ad-

ditional quantity of succinate of ammonia was added. And we precipitate fell; but instead of the dark reddish-brown colour, which characterizes succinate of iron, it had a beautiful flesh-red colour, which it retained after being dried in the open air. When heated to redness in a covered crucible, it became black, and had some resemblance to gunpowder. It weighed 7.2 grains.

4. THIS substance attracted my peculiar attention, in consequence of its appearance. I found it to possess the following characters:

a. IT was tasteless, and not in the least attracted by the magnet, except a few atoms, which were easily separated from the rest.

b. IT was insoluble in water, and not sensibly acted on when boiled in sulphuric, nitric, muriatic, or nitro-muriatic acid.

c. BEFORE the blow-pipe it melted with borax and microcosmic salt, and formed with both a colourless bead. With carbonate of soda it formed a dark-red opaque bead.

d. WHEN heated to redness with potash, and digested in water, snuff-coloured flocks remained undissolved, which gradually subsided to the bottom. The liquid being separated, and examined, was found to contain nothing but potash. When muriatic acid was poured upon the snuff-coloured flocks, a slight effervescence took place, and when heat was applied, the whole dissolved. The solution was transparent, and of a yellow colour, with a slight tint of green. When evaporated to dryness, to get rid of the excess of acid, a beautiful yellow matter gradually separated. Water boiled upon this matter dissolved the whole. The taste of the solution was astringent, with a slight metallic flavour, by no means unpleasant, and no sweetness was perceptible.

e. A

iii. A PORTION of the black powder being exposed to a red heat for an hour, in an open crucible, became reddish-brown, and lost somewhat of its weight. In this altered state, it was soluble by means of heat, though with difficulty, both in nitric and sulphuric acids. The solutions had a reddish-brown colour, a slight metallic astringent taste, but no sweetness.

f. THE solution of this matter in nitric and muriatic acid, when examined by re-agents, exhibited the following phenomena :

- (1.) With prussiate of potash, it threw down a white precipitate in flocks. It soon subsided ; readily dissolved in nitric acid ; the solution was green.
 - (2.) Prussiate of mercury. A light yellow precipitate, soluble in nitric acid.
 - (3.) Infusion of nut galls. No change.
 - (4.) Gallic acid. No change.
 - (5.) Oxalate of ammonia. No change.
 - (6.) Tartrate of potash. No change.
 - (7.) Phosphate of soda. No change.
 - (8.) Hydro-sulphuret of ammonia. Copious black flocks. Liquor remains transparent.
 - (9.) Arseniate of potash. A white precipitate.
 - (10.) Potash. - - -
 - (11.) Carbonate of soda. - - -
 - (12.) Carbonate of ammonia. - - -
- } Copious yellow-coloured
flocks ; readily dissolved in
nitric acid.
- (13.) Succinate of ammonia. A white precipitate.
 - (14.) Benzoate of potash. A white precipitate.
 - (15.) A plate of zinc being put into the solution in muriatic acid, became black, and threw down a black powder, which was insoluble in sulphuric, nitric, muriatic, nitro-muriatic, acetic, and phosphoric acids, in every

3 B 2
temperature,

temperature, whether these acids were concentrated or diluted.

- (16.) A plate of tin put into the nitric solution, occasioned no change.
- (17.) A portion being inclosed in a charcoal crucible, and exposed for an hour to the heat of a forge, was not reduced to a metallic button, nor could any trace of it be detected when the crucible was examined.

THESE properties were all that the small quantity of the matter in my possession enabled me to ascertain. They unequivocally point out a metallic oxide. Upon comparing them with the properties of all the metallic oxides known, none will be found with which this matter exactly agrees. Cerium is the metal, the oxides of which approach the nearest. The colour is nearly the same, and both are precipitated white by prussiate of potash, succinate of ammonia, and benzoate of potash. But, in other respects, the two substances differ entirely. Oxide of cerium is precipitated white by oxalate of ammonia and tartrate of potash; our oxide is not precipitated at all: Oxide of cerium is precipitated white by hydro-sulphuret of ammonia; while our oxide is precipitated black: Oxide of cerium is not precipitated by zinc, while our oxide is thrown down black. There are other differences between the two, but those which I have just mentioned are the most striking.

THESE properties induced me to consider the substance which I had obtained from the Greenland mineral as the oxide of a metal hitherto unknown; and I proposed to distinguish it by the name of *Junonium*.

IN the experiments above detailed, I had expended almost all the oxide of *Junonium* which I had in my possession, taking it for granted that I could easily procure more of it from the Greenland

land mineral. But, soon after, I was informed by Dr WOLLASTON, to whom I had sent a specimen of the mineral, that he had not been able to obtain any of my supposed Junonium in his trials. This induced me to repeat the analysis no less than three times, and in neither case was I able to procure any more of the substance which I have described above. Thus, it has been out of my power, to verify the preceding details, and to put the existence of a new metal in the mineral beyond doubt. At the same time, I may be allowed to say, that the above experiments were made with every possible attention on my part, and most of them were repeated, at least a dozen times. I have no doubt myself of their accuracy; but think that the existence of a new metal can hardly be admitted, without stronger proofs than the solitary analysis which I have performed.

5. THE liquid, thus freed from iron and junonium, was supersaturated with pure ammonia. A greyish-white gelatinous matter precipitated. It was separated by the filtre, and became gradually darker coloured when drying. This matter, after being exposed to a red heat, weighed about 38 grains. When boiled in potash-ley, 4.1 grains were dissolved, of a substance which, separated in the usual way, exhibited the properties of alumina.

6. THE remaining 33.9 grains were again dissolved in muriatic acid, and precipitated by pure ammonia. The precipitate was separated by the filtre, and allowed to dry spontaneously in the open air. It assumed an appearance very much resembling gum-arabic, being semi-transparent, and of a brown colour. When dried upon the sand-bath, it became very dark-brown, broke with a vitreous fracture, and still retained a small degree of transparency. It was tasteless, felt gritty between the teeth, and was easily reduced to powder. It effervesced in sulphuric, nitric, muriatic, and acetic acids, and a solution of it

was

was effected in each by means of heat, though not without considerable difficulty. The solutions had an austere, and slightly sweetish taste. When examined by re-agents, they exhibited the following properties :

- (1.) Pruffiate of potash. A white precipitate.
- (2.) Oxalate of ammonia. A white precipitate.
- (3.) Tartrate of potash. A white precipitate.
- (4.) Hydrofulphuret of potash. A white precipitate.
- (5.) Phosphate of soda. A white precipitate.
- (6.) Arseniate of potash. A white precipitate.
- (7.) Potash and its carbonate. A white precipitate.
- (8.) Carbonate of ammonia. A white precipitate.
- (9.) Ammonia. A white gelatinous precipitate.
- (10.) A plate of zinc. No change.

THESE properties indicated Oxide of Cerium. I was therefore disposed to consider the substance which I had obtained as oxide of cerium. But on perusing the accounts of that substance, given by the celebrated chemists to whose labours we are indebted for our knowledge of it, there were several circumstances of ambiguity which occurred. My powder was dissolved in acids with much greater difficulty than appeared to be the case with oxide of cerium. The colour of my oxide, when obtained from oxalate, by exposing it to a red heat, was much lighter, and more inclined to yellow, than the oxide of cerium.

IN this uncertainty, Dr WOLLASTON, to whom I communicated my difficulties, offered to send me down a specimen of the mineral called *ceyite*, that I might extract from it real oxide of cerium, and compare my oxide with it. This offer I thankfully

fully accepted *; and upon comparing the properties of my oxide with those of oxide of cerium extracted from *cerite*, I was fully satisfied that they were identical. The more difficult solubility of mine, was owing to the method I had employed to procure it, and to the strong heat to which I had subjected it; whereas the oxide of cerium from *cerite* had been examined in the state of carbonate.

7. IN the many experiments made upon this powder, and upon oxide of cerium from *cerite*, I repeated every thing that had been established by BERZELIUS and HISINGER, KLAPROTH and VAUQUELIN, and had an opportunity of observing many particulars which they have not noticed. It may be worth while, therefore, without repeating the details of these chemists, to mention a few circumstances, which will be found useful in examining this hitherto scarce oxide.

a. THE precipitate occasioned by oxalate of ammonia is at first in white flocks, not unlike that of muriate of silver, but it soon assumes a pulverulent form. It dissolves readily in nitric acid, without the assistance of heat. The same remark applies to the precipitate thrown down by tartrate of potash. But tartrate of cerium is much more soluble in acids than the oxalate.

b. THE

* THE specimen of *cerite* which I analysed, was so much mixed with actinolite, that the statement of the results which I obtained cannot be of much importance. The specific gravity of the specimen was 4.149. I found it composed as follows:

A white powder, left by muriatic acid, and presumed to be silica,	47.3
Red oxide of cerium,	44.
Iron,	4.
Volatile matter,	3.
Loss,	1.7
	<hr/>
	100.0

b. THE solution of cerium in acetic acid is precipitated grey by infusion of nut-galls. Cerium is precipitated likewise by the same re-agent from other acids, provided the solution contain no excess of acid. This fact was first observed by Dr WOLLASTON, who communicated it to me last summer. I immediately repeated his experiments with success.

c. CERIUM is not precipitated from its solution in acids by a plate of zinc. In some cases, indeed, I have obtained a yellowish-red powder, which was thrown down very slowly. But it proved, on examination, to consist almost entirely of red oxide of iron, and of course only appeared when the solution of cerium was contaminated with iron.

d. THE solutions of cerium in acids have an astringent taste, with a perceptible sweetness, which, however, is different from the sweetness which some of the solutions of iron in acids possess.

e. THE muriate and sulphate of cerium readily crystallise; but I could not succeed in obtaining crystals of nitrate of cerium.

f. THE best way of obtaining pure oxide of cerium, is to precipitate the solution by oxalate of ammonia, wash the precipitate well, and expose it to a red heat. The powder obtained by this process is always red; but it varies very much in its shade, and its beauty, according to circumstances. This powder always contains carbonic acid.

g. I CONSIDER the following as the essential characters of cerium. The solution has a sweet astringent taste: It is precipitated white by prussiate of potash, oxalate of ammonia, tartrate of potash, carbonate of potash, carbonate of ammonia, succinate of ammonia, benzoate of potash, and hydrosulphuret of ammonia: The precipitates are re-dissolved by nitric or muriatic acids:

acids: Ammonia throws it down in gelatinous flocks: Zinc does not precipitate it at all.

b. THE white oxide of cerium, mentioned by HISINGER and BERZELIUS, and described by VAUQUELIN, did not present itself to me in any of my experiments; unless the white flocks precipitated by ammonia from the original solution be considered as white oxide. They became brown on drying, and when heated to redness, were certainly converted into red oxide.

As cerium, as well as iron, is precipitated by fuccinate of ammonia, the preceding method of separating the two from each other was not unexceptionable. Accordingly, in some subsequent analyses, I separated the cerium by means of oxalate of ammonia, before I precipitated the iron. I found that the proportions obtained by the analysis above described, were so near accuracy that no material alteration is necessary.

8. THE liquid, thus freed from iron, alumina, and cerium, was mixed with carbonate of soda. It precipitated a quantity of carbonate of lime, which amounted, as before, to about 17 grains, indicating 9.2 grains of lime.

FROM the preceding analysis, which was repeated no less than three times, a different method being employed in each, the constituents of allanite are as follows:

Silica,	-	-	-	35.4
Lime,	-	-	-	9.2
Alumina,	-	-	-	4.1
Oxide of iron,	-	-	-	25.4
Oxide of cerium,	-	-	-	33.9
Volatile matter,	-	-	-	4.
				<hr/>
				112.0

I omit the 7 grains of junonium, because I only detected it in one specimen of allanite. The excess of weight in the preceding numbers, is to be ascribed chiefly to the carbonic acid combined with the oxide of cerium, from which it was not completely freed by a red heat. I have reason to believe, too, that the proportion of iron is not quite so much as 25.5 grains. For, in another analysis, I obtained only 18 grains, and in a third 20 grains. Some of the cerium was perhaps precipitated along with it in the preceding analysis, and thus its weight was apparently increased.

XII. *A Chemical Analysis of Sodalite, a new Mineral from Greenland.* BY THOMAS THOMSON, M. D. F. R. S. E.
Fellow of the Imperial Chirurgo-Medical Academy of Petersburgh.

[Read Nov. 5. 1810.]

THE mineral to which I have given the name of *Sodalite*, was also put into my hands by Mr ALLAN. In the Greenland collection which he purchased, there were several specimens of a rock, obviously primitive. In the composition of these, the substance of which I am about to treat, formed a constituent, and, at first appearance, was taken for felspar, to which it bears a very striking resemblance.

THIS rock is composed of no less than five different fossils, namely, garnet, hornblende, augite, and two others, which form the paste of the mass. These are evidently different minerals; but in some specimens, are so intimately blended, that it required the skill of Count BOURNON to make the discrimination, and ascertain their real nature. Even this distinguished mineralogist was at first deceived by the external aspect, and considered the paste as common lamellated felspar, of a greenish colour. But a peculiarity which presented itself to Mr ALLAN, in one of the minerals, induced him to call the attention of Count BOURNON more particularly to its construction.

ON a closer examination of the mineral, M. de BOURNON found that some small fragments, which he had detached, pre-

ented rectangular prisms, terminated by planes, measuring, with the sides of the prism, 110° and 70° or nearly so,—a form which belongs to a rare mineral, known by the name of Sahlite, from Sweden. He further observed, intermixed along with this, another material; and after some trouble, succeeded in detaching a mass, presenting a regular rhomboidal dodecahedron. It was to this form that Mr ALLAN had previously requested his attention.

SOME time before this investigation, M. de BOURNON had examined a mineral from Sweden, of a lamellated structure, and a greenish colour, which, he found, indicated the same form. From this circumstance, together with some external resemblance, which struck him, he was induced to conclude, that our mineral was a variety of that substance.

To that substance the name of Swedish *natrolite* had been given, in consequence of the investigation of Dr WOLLASTON, who found that it contained a large proportion of soda.

THERE are few minerals, however, that are so totally distinct in their external characters as the natrolite of KLAPROTH, and the substance we are now treating of. The mineral examined by KLAPROTH occurs at Roegan*, on the Lake of Constance, in porphyry-slate, coating the sides of veins and cavities in a mammellated form, the texture of which is compact, fibrous, and radiated; the colour pale yellow, in some places passing into white, and marked with brown zones. Hitherto it had never been found in a state sufficiently perfect to afford any indications of form. Lately, however, M. de BOURNON was so fortunate as to procure some of it, presenting very delicate needleform crystals, which, by means of a strong magnifier, he was able to ascertain, presented flat rectangular prisms, terminated by planes, which, he thought, might form angles of 60°

* IT has been observed also by Professor JAMIESON, in the fletz-trap rocks behind Burntisland.

60° and 120 with the sides of the prism. With this, neither our mineral nor the Swedish can have any connection, farther than some analogy which may exist in their composition.

CONCERNING the Swedish mineral, I have not been able to obtain much satisfactory information. There is a specimen of it in Mr ALLAN's cabinet, which he received directly from Sweden, sent by a gentleman who had just before been in London, and was well acquainted with the collections of that city, from which it is inferred, that the specimen in question is the same as that examined by Count BOURNON and Dr WOLLASTON.

WERNER has lately admitted into his system a new mineral species, which he distinguishes by the name of *Fettstein*. Of this I have seen two descriptions; one by HAÜY, in his *Tableau Comparatif*, published last year; and another by Count DUNIN BORKOWSKI, published in the 69th volume of the *Journal de Physique*, and translated in *Nicholson's Journal*, (vol. 26. p. 384). The specimen, called *Swedish Natrolite*, in Mr ALLAN's possession, agrees with these descriptions in every particular, excepting that its specific gravity is a little higher. BORKOWSKI states the specific gravity of *fettstein* at 2.563; HAÜY at 2.6138; while I found the specific gravity of Mr ALLAN's specimen to be 2.779, and, when in small fragments, to be as high as 2.790. This very near agreement in the properties of the Swedish natrolite, with the characters of the *fettstein*, leads me to suppose it the substance to which WERNER has given that name. This opinion is strengthened, by a fact mentioned by HAÜY, that *fettstein* had been at first considered as a variety of *Wernerite*. For the specimen sent to Mr ALLAN, under the name of *Compact Wernerite*, is obviously the very same with the supposed natrolite of Sweden. Now, if this identity be admitted, it will follow, that our mineral constitutes a species apart. It bears, indeed, a considerable resemblance to it; but neither the crystalline form, nor the constituents of *fettstein*,

as stated by HAUVY, are similar to those of the mineral to which I have given the name of Sodalite. The constituents of festslein, as ascertained by VAUQUELIN, are as follows :

Silica,	-	-	-	44.00
Alumina,	-	-	-	34.00
Oxidè of iron,	-	-	-	4.00
Lime,	-	-	-	0.12
Potash and soda,	-	-	-	16.50
Loss,	-	-	-	1.38
				<hr/>
				100.00

II. DESCRIPTION OF SODALITE.

SODALITE, as has been already mentioned, occurs in a primitive rock, mixed with fahlite, augite *, hornblende, and garnet †.

IT occurs massive ; and crystallised, in rhomboidal dodecahedrons, which, in some cases, are lengthened, forming six-sided prisms, terminated by trihedral pyramids.

ITS colour is intermediate between celandine and mountain green, varying in intensity in different specimens. In some cases it seems intimately mixed with particles of fahlite, which doubtless modify the colour.

EXTERNAL lustre glimmering, internal shining, in one direction vitreous, in another resinous.

FRACTURE foliated, with at least a double cleavage ; cross fracture conchoidal.

FRAGMENTS indeterminate ; usually sharp-edged.

TRANSLUCENT.

* THIS situation of the augite deserves attention. Hitherto it has been, with a few exceptions, found only in stætz trap rocks.

† THE particular colour and appearance of this garnet, shews that the rock came from Greenland : For similar garnet has never been observed, except in specimens from Greenland.

TRANSLUCENT.

HARDNESS equal to that of felspar. Iron scratches it with difficulty.

BRITTLE.

EASILY frangible.

SPECIFIC gravity, at the temperature of 60°, 2.378. The specimen was not absolutely free from fahlite.

WHEN heated to redness, does not decrepitate, nor fall to powder, but becomes dark-grey, and assumes very nearly the appearance of the Swedish natrolite of Mr ALLAN, which I consider as fettstein. If any particles of fahlite be mixed with it, they become very conspicuous, by acquiring a white colour, and the opacity and appearance of chalk. The loss of weight was 2.1 per cent. I was not able to melt it before the blow-pipe.

II. CHEMICAL ANALYSIS.

1. A HUNDRED grains of the mineral, reduced to a fine powder, were mixed with 200 grains of pure soda, and exposed for an hour to a strong red heat, in a platinum crucible. The mixture melted, and assumed, when cold, a beautiful grass-green colour. When softened with water, the portion adhering to the sides of the crucible acquired a fine brownish-yellow. Nitric acid being poured upon it, a complete solution was obtained.

2. SUSPECTING, from the appearance which the fused mass assumed, that it might contain chromium, I neutralised the solution, as nearly as possible, with ammonia, and then poured into it a recently prepared nitrate of mercury. A white precipitate fell, which being dried, and exposed to a heat rather under redness, was all dissipated, except a small portion of grey matter,

matter, not weighing quite 0.1 grain. This matter was infoluble in acids; but became white. With potafh it fufed into a colourlefs glafs. Hence I confider it as filica. This experiment fhews that no chromium was prefent. I was at a lofs to account for the precipitate thrown down by the nitrate of mercury. But Mr ALLAN having fhown me a letter from EKEBERG, in which he mentions, that he had detected muriatic acid in fodalite, it was eafy to fee that the whole precipitate was calomel. The white powder weighed 26 grains, indicating, according to the analyfis of CHENEVIX, about 3 grains of muriatic acid.

3. THE folution, thus freed from muriatic acid, being concentrated by evaporation, gelatinifed. It was evaporated nearly to drynefs; the dry mafs, digefted in hot water acidulated with nitric acid, and poured upon the filter. The powder retained upon the filter was washed, dried, and heated to rednefs. It weighed 37.2 grains, and was filica.

4. THE liquor which had paffed through the filter, was fuperfaturated with carbonate of potafh, and the copious white precipitate which fell, collected by the filter, and boiled while yet moift in potafh-ley. The bulk diminifhed greatly, and the undiffolved portion affumed a black colour, owing to fome oxide of mercury with which it was contaminated.

5. THE potafh-ley being paffed through the filter, to free it from the undiffolved matter, was mixed with a fufficient quantity of fal-ammoniac. A copious white precipitate fell, which being collected, washed, dried, and heated to rednefs, weighed 27.7 grains. This powder being digefted in fulphuric acid, diffolved, except 0.22 grain of filica. Sulphate of potafh being added, and the folution fet afide, it yielded alum crystals to the very laft drop. Hence the 27.48 grains of diffolved powder were alumina.

6. THE

6. THE black residue which the potash-ley had not taken up, was dissolved in diluted sulphuric acid. The solution being evaporated to dryness, and the residue digested in hot water, a white soft powder remained, which, heated to redness, weighed 3.6 grains, and was sulphate of lime, equivalent to about 2 grains of lime.

7. THE liquid from which the sulphate of lime was separated, being exactly neutralised by ammonia, succinate of ammonia was dropped in; a brownish-red precipitate fell, which, being heated to redness in a covered crucible, weighed 1 grain, and was black oxide of iron.

8. THE residual liquor being now examined by different reagents, nothing farther could be precipitated from it.

9. THE liquid (No. 4.) from which the alumina, lime, and iron had been separated by carbonate of potash, being boiled for some time, let fall a small quantity of yellow-coloured matter. This matter being digested in diluted sulphuric acid, partly dissolved with effervescence; but a portion remained undissolved, weighing 1 grain. It was insoluble in acids, and with potash melted into a colourless glass. It was therefore silica. The sulphuric acid solution being evaporated to dryness, left a residue, which possessed the properties of sulphate of lime, and which weighed 1.2 grains, equivalent to about 0.7 grains of lime.

10. THE constituents obtained by the preceding analysis being obviously defective, it remained to examine whether the mineral, according to the conjecture of BOURNON, contained an alkali. For this purpose, 100 grains of it, reduced to a fine powder, and mixed with 500 grains of nitrate of barytes, were exposed for an hour to a red heat, in a porcelain crucible. The fused mass was softened with water, and treated with muriatic acid. The whole dissolved, except 25 grains of a white powder,

der, which proved on examination to be silica. The muriatic acid solution was mixed with sulphuric acid, evaporated to dryness; the residue, digested in hot water, and filtered, to separate the sulphate of barytes. The liquid was now mixed with an excess of carbonate of ammonia, boiled for an instant or two, and then filtered, to separate the earth and iron precipitated by the ammonia. The liquid was evaporated to dryness, and the dry mass obtained exposed to a red heat in a silver crucible. The residue was dissolved in water, and exposed in the open air to spontaneous evaporation. The whole gradually shot into regular crystals of sulphate of soda. This salt being exposed to a strong red heat, weighed 50 grains, indicating, according to BERTHOLLET's late analysis, 23.5 grains of pure soda. It deserves to be mentioned, that during this process, the silver crucible was acted on, and a small portion of it was afterwards found among the sulphate of soda. This portion was separated before the sulphate of soda was weighed.

THE preceding analysis gives us the constituents of sodalite as follows :

Silica,	-	-	-	38.52
Alumina,	-	-	-	27.48
Lime,	-	-	-	2.70
Oxide of iron,	-	-	-	1.00
Soda,	-	-	-	23.50
Muriatic acid,	-	-	-	3.00
Volatile matter,	-	-	-	2.10
Loss,	-	-	-	1.70
				<hr/>
				100.00

Mr ALLAN sent a specimen of this mineral to Mr EKEBERG, who analysed it in the course of last summer. The constituents which he obtained, as he states them in a letter to Mr ALLAN, are as follows :

Silica,	-	-	-	36.
Alumina,	-	-	-	32.
Soda,	-	-	-	25.
Muriatic acid,	-	-	-	6.75
Oxide of iron,	-	-	-	0.25
				<hr/>
				100.00

THIS result does not differ much from mine. The quantity of muriatic acid is much greater than mine. The lime and the volatile matter which I obtained, escaped his notice altogether. If we were to add them to the alumina, it would make the two analyses almost the same. No mineral has hitherto been found containing nearly so much *soda* as this. Hence the reason of the name by which I have distinguished it.

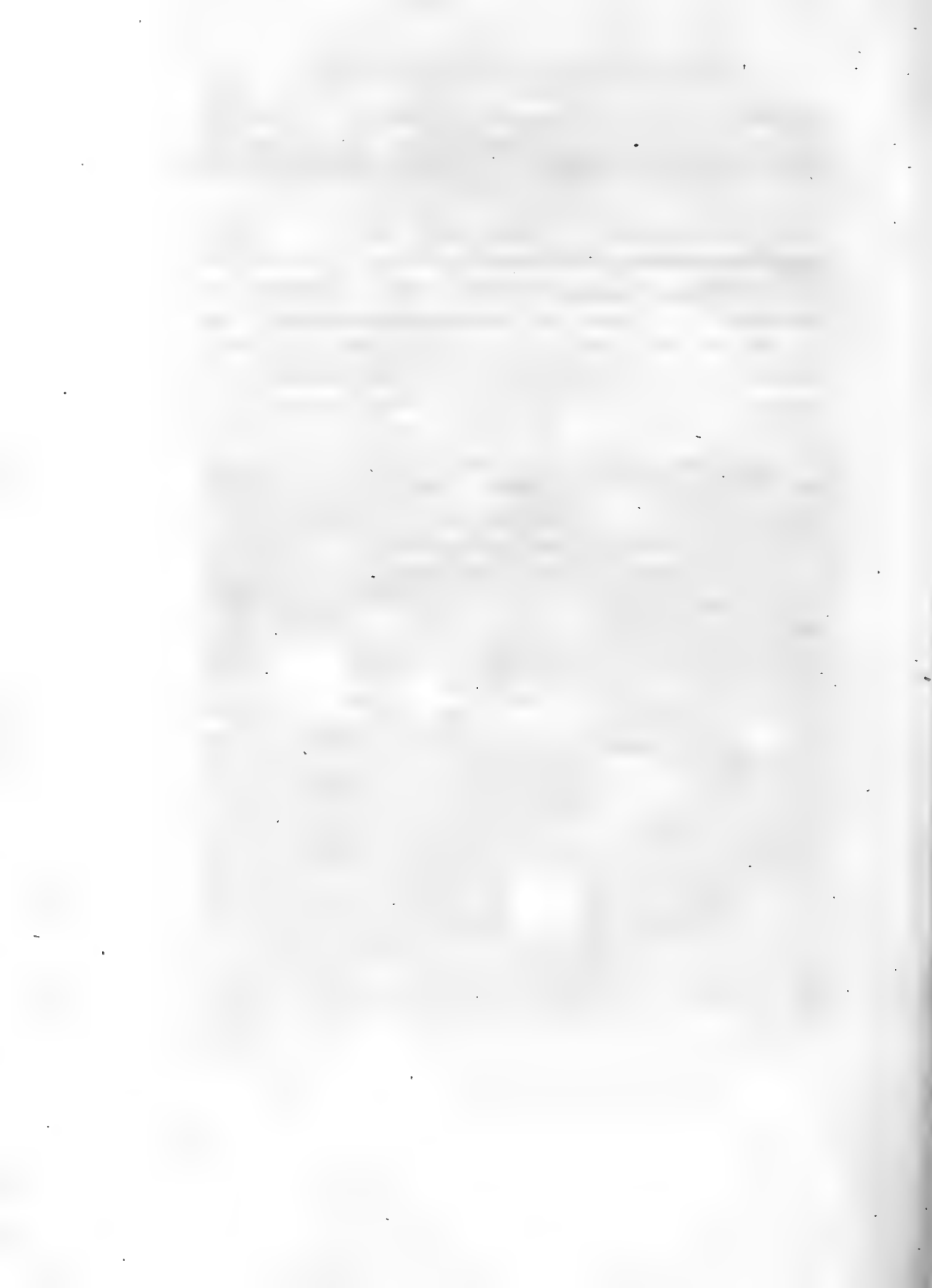

XIII. *Demonstration of the Fundamental Property of the Lever.*

By DAVID BREWSTER, LL. D. F. R. S. EDIN.

[*Read December 3. 1810.*]

IT is a singular fact in the history of science, that, after all the attempts of the most eminent modern mathematicians, to obtain a simple and satisfactory demonstration of the fundamental property of the lever, the solution of this problem given by ARCHIMEDES, should still be considered as the most legitimate and elementary. GALILEO, HUYGENS, DE LA HIRE, Sir ISAAC NEWTON, MACLAURIN, LANDEN, and HAMILTON, have directed their attention to this important part of mechanics; but their demonstrations are in general either tedious and abstruse, or founded on assumptions too arbitrary to be recognised as a proper basis for mathematical reasoning. Even the demonstration given by ARCHIMEDES is not free from objections, and is applicable only to the lever, considered as a physical body. GALILEO, though his demonstration is superior in point of simplicity to that of ARCHIMEDES, resorts to the inelegant contrivance, of suspending a solid prism from a mathematical lever, and of dividing the prism into two unequal parts, which act as the power and the weight. The demonstration given by HUYGENS, assumes as an axiom, that a given weight
removed

removed from the fulcrum, has a greater tendency to turn the lever round its centre of motion, and is, besides, applicable only to a commensurable proportion of the arms. The foundation of Sir ISAAC NEWTON'S demonstration is still more inadmissible. He assumes, that if a given power act in any direction upon a lever, and if lines be drawn from the fulcrum to the line of direction, the mechanical effort of the power will be the same when it is applied to the extremity of any of these lines; but it is obvious, that this axiom is as difficult to be proved as the property of the lever itself. M. DE LA HIRE has given a demonstration which is remarkable for its want of elegance. He employs the *reductio ad absurdum*, and thus deduces the proposition from the case where the arms are commensurable. The demonstration given by MACLAURIN has been highly praised; but if it does not involve a *petitio principii*, it has at least the radical defect, of extending only to a commensurable proportion of the arms. The solutions of LANDEN and HAMILTON are peculiarly long and complicated, and resemble more the demonstration of some of the abstrusest points of mechanics, than of one of its simplest and most elementary truths.

IN attempting to give a new demonstration of the fundamental property of the lever, which shall be at the same time simple and legitimate, we shall assume only one principle, which has been universally admitted as axiomatic, namely, *that equal and opposite forces, acting at the extremities of the equal arms of a lever, and at equal angles to these arms, will be in equilibrio.* With the aid of this axiom, the fundamental property of the lever may be established by the three following propositions.

IN PROP. I. the property is deduced in a very simple manner, when the arms of the lever are commensurable.

IN

IN PROP. II., which is totally independent of the first, the demonstration is general, and extends to any proportion between the arms.

IN PROP. III. the property is established, when the forces act in an oblique direction, and when the lever is either rectilinear, angular, or curvilinear. In the demonstrations which have generally been given of this last proposition, the oblique force has been resolved into two, one of which is directed to the fulcrum, while the other is perpendicular to that direction. It is then assumed, *that the force directed to the fulcrum has no tendency to disturb the equilibrium, even though it acts at the extremity of a bent arm*; and hence it is easy to demonstrate, that the remaining force is proportional to the perpendicular drawn from the fulcrum to the line of direction in which the original force was applied. As the principle thus assumed, however, is totally inadmissible as an intuitive truth, we have attempted to demonstrate the proposition without its assistance.

PROP. I.—*If one arm of a straight lever is any multiple of the other, a force acting at the extremity of the one will be in equilibrio with a force acting at the extremity of the other, when these forces are reciprocally proportioned to the length of the arms to which they are applied.*

LET AB (PLATE XI. fig. 1.) be a lever supported on the two fulcra F, f , so that $Af = fF = FB$. Then, if two equal weights C, D , of 1 pound each, be suspended from the extremities A, B , they will be in equilibrio, since they act at the end of equal arms Af, BF ; and each of the fulcra f, F , will support an equal part of the whole weight, or 1 pound. Let the fulcrum f be now removed, and let a weight E , of 1 pound, act upwards at the point f ; the equilibrium will still continue; but the weight E , of 1 pound, acting upwards at f , is equivalent to a weight G of 1 pound, acting downwards at B . Remove, therefore, the weight E ,

E, and suspend the weight G from B; then, since the equilibrium is still preserved after these two substitutions, we have a weight C, of one pound, acting at the extremity of the arm AF, in equilibrio with the weights D and G, which together make two pounds, acting at the extremity of the arm FB. But FA is to FB as 2 is to 1; therefore an equilibrium takes place, when the weights are reciprocally proportional to the arms, in the particular case when the arms are as 2 to 1. By making Ff successively double, triple, &c. of FB, it may in like manner be shewn, that, in these cases, the proposition holds true.

LEMMA.

If any weight BCcb, (fig. 2. No. 1.), of uniform shape and density, is placed on a lever Aφ, whose fulcrum is φ, it has the same tendency to turn the lever round φ, as if it were suspended from a point G, so taken that $bG = Gc$.

IF a weight W, of the same magnitude with BC, acts upwards at the point G, it will be in equilibrium with the weight BC, and will therefore destroy the tendency of that weight to turn the lever round φ. But the weight W, acting upwards at the point G, has the same power to turn the lever round φ, as an equal weight w, acting downwards at G. Consequently the tendency of the weight BC to turn the lever round φ, is the same as the tendency of an equal weight w, acting downwards at G.

PROP. II.

If two forces applied to a lever, and acting at right angles to it, have the same tendency to turn the lever round its centre of motion, they are reciprocally proportional to the distances of the points at which they are applied from the centre of motion.

LET Aφd, (fig. 2. No. 2.) be a lever whose fulcrum is φ, and let it be loaded with a weight BDdb of uniform shape and density.

fitly. Then by the lemma, this weight has the same tendency to turn the lever round, as if it were suspended from the point n , so taken that $bn = dn$. Make $\phi c = \phi d$, and let the weight $BD db$ be divided at the points C and F , by the lines Cc , $F\phi$. The weights $CF \phi c$, $DF \phi d$, being in equilibrio, by the axiom, have no tendency to turn the lever round ϕ , consequently the remaining weight $BC cd$, has the same tendency to turn the lever round ϕ as the whole weight $BD db$. Hence if $bm = cm$, the weight $BC cb$ acting at the point m , will have the same tendency to turn the lever round ϕ , as the weight $BD db$ acting at n . Now $BD db : BC cb = bd : bc = nd : mc$; and since $bc = bd - cd$, we have $mc = \frac{1}{2}bd - \frac{1}{2}cd = nd - \frac{1}{2}cd = n\phi$, and $nd = n\phi + \frac{1}{2}cd = mc + \frac{1}{2}cd = m\phi$. Consequently,

$$BD db : BC cb = m\phi : n\phi.$$

LEMMA.

Two equal forces acting at the same point of the arm of a lever, and in directions which form equal angles with a perpendicular drawn through that point of the arm, will have equal tendencies to turn the lever round its centre of motion.

LET AB (fig. 3.) be a lever with equal arms AF , FB . Through the points A , B , draw AD , BE , perpendicular to AB , and AP , $A\rho$, BW , Bw , forming equal angles with the lines AD , BE . Produce PA to M . Then, equal forces acting in the directions AP , Bw , will be in equilibrio. But a force M equal to P , and acting in the direction AM , will counteract the force P , acting in the direction AB , or will have the same tendency to turn the lever round F ; and the force W , acting in the direction BW , will have the same tendency to turn the lever round F as the

the force M : Consequently the force W will have the same tendency to turn the lever round F as the force w ; and this will hold true, whether the arms AF , FB , are straight or curvilinear, provided that they are both of the same form.

PROP. III.—*If a force acts in different directions at the same point in the arm of a lever, its tendency to turn the lever round its centre of motion, will be proportional to the perpendiculars let fall from that centre on the lines of direction in which the force is applied.*

LET AB , (fig. 4.) be the lever, and let the two equal forces BM , Bm , act upon it at the point B , in the direction of the lines BM , Bm . Draw BN , Bn , respectively equal to BM , Bm , and forming the same angles with the line PB perpendicular to AB . To BM , Bm , BN , Bn , produced, draw the perpendiculars AY , Ay , AX , Ax . Now, the side $AX = AY$, and $Ax = Ay$, on account of the equality of the triangles ABX , ABY ; and if Bl , $B\lambda$, be drawn perpendicular to $B\omega$, the triangles ABY , $Bm\lambda$, will be similar, and also the triangles ABY , $Bm\lambda$: Hence we obtain

$$AB : AY = BM : Bl, \text{ and}$$

$$AB : Ay = BM : B\lambda$$

Therefore, *ex æquo*, $AY : Ay = Bl : B\lambda$.

Complete the parallelograms $BM\omega N$, $Bm\omega n$, and Bl , $B\lambda$ will be respectively one-half of the diagonals $B\omega$, $B\omega$.

Now let two equal forces BM , BN , act in these directions upon the lever at B , their joint force will be represented by the diagonal $B\omega$, and consequently one of the forces BM will be

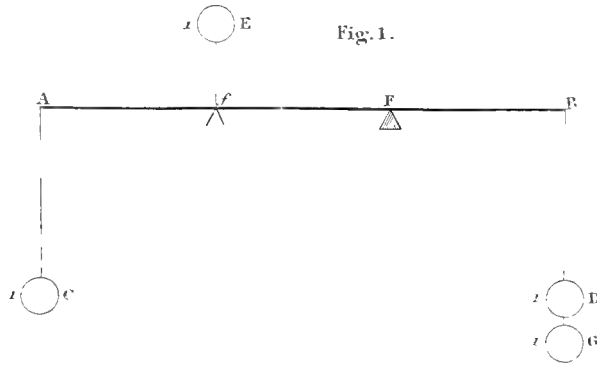

Fig. 2. N^o 1.



Fig. 2. N^o 2.

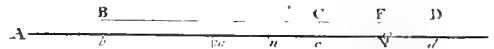

Fig. 3.

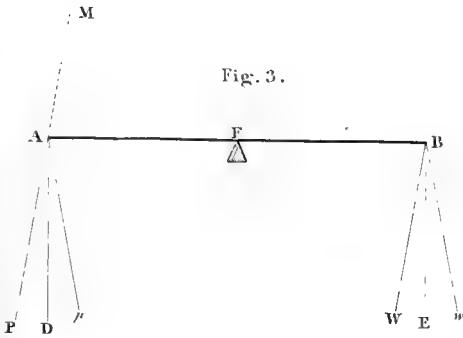
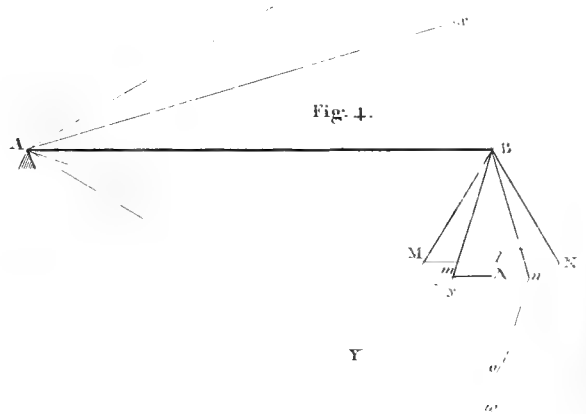

Fig. 4.





be represented by $B l = \frac{1}{2} B o$. In the same manner, if the two equal forces $B m, B n$, act upon the lever at B , their joint force will be represented by $B \omega$, and one of them, $B m$, will be represented by $B \lambda = \frac{1}{2} B \omega$. Consequently the power of the two forces $B M, B m$, to turn the lever round its centre of motion, is represented by $B l, B \lambda$, respectively; that is, the force $B M$ is to the force $B m$ as $B l$ is to $B \lambda$; that is, as $A Y$ is to $A y$, the perpendiculars let fall upon the lines of their direction.

XIV. *On the Rocks in the vicinity of Edinburgh.* By

THOMAS ALLAN, Esq; F. R. S. EDIN.

[*Read March 4. 1811.*]

ALTHOUGH science has only within these few years acknowledged the importance of Geology, the eagerness with which it has been cultivated, affords sufficient proof of the interest it is capable of creating. Of this we have a recent example in the laborious undertaking of Sir GEORGE MACKENZIE and his friends, who, notwithstanding all the dangers presented by a voyage through the most tempestuous ocean, and the deprivations to which they were exposed, in a journey through a country destitute of the slightest trace to guide the route of the traveller, were not deterred from exploring the inhospitable shores of Iceland. These, and other travellers, have extended our knowledge of various districts on the surface of the globe; but we have still to lament the extreme imperfection of the science, which, as yet, has assumed no decided character or form. This appears principally owing to the want of some simple method, grounded on clear and intelligible principles:

ples; perhaps also, to its having always been the object of those who have treated the subject, to accommodate their observations to a particular theory; and when this is the case, it is obvious, that the mind cannot refuse itself the satisfaction, of dwelling with comparative enthusiasm on facts which appear favourable to the adopted system; while others of a different tendency, are either reluctantly, and therefore superficially considered, or what is yet worse, even studiously avoided.

IN the present state of our knowledge, to divest geology of theory, would be to deprive it of all its interest. We must not despair, however, that by the multiplication of particular facts, and the exposition of others, with which we are still unacquainted, a system of geology may yet be formed, founded exclusively on the phenomena of nature, or at least on reasoning much less hypothetical than is now required.

THE most obvious means of attaining this object, seems to be a careful, minute, and candid examination of every circumstance which appears to convey an explanation of itself, without reference to any theory; and from these we may ultimately hope to obtain some data, equally certain and comprehensive.

It is with this view, that I have always formed my collections of geological specimens; and although it will appear, that the arguments I have deduced are favourable to one set of opinions, yet I can assert with confidence, that the district which it is the object of the present paper to examine, has been faithfully explored, and, I hope, candidly described.

It is generally admitted, that no city in Europe is more favourably situated than the metropolis of Scotland, for the study and pursuit of geology: even the ground which it occupies, when laid open for the erection of buildings, has occasionally presented some very interesting phenomena. The hills in the immediate neighbourhood, always at command, afford a never-failing source of research; and in the surrounding country, a greater variety of fossils is to be met with, than almost in any space of the same extent.

THE importance of a complete acquaintance with the phenomena which surround this city, cannot therefore, I think, be considered of a trivial nature. Indeed, by the number of ingenious works already before the public, it may be thought that the subject is exhausted. But this is an error I am very desirous to combat, not only because in my own experience I have found it to be one, but because, as science advances, our habits of investigation improve, phenomena become more familiar, we learn to trace and to seize not only the objects we are in pursuit of, but also to detect others, which our less practised eye had originally passed over unnoticed.

WE all think ourselves perfectly acquainted with the rock, on which our Castle stands. But I suspect there are many members of this Society, who will be surprised to learn, that sandstone occurs near its summit, and also at its base. Salisbury

Salisbury Craig and Arthur's Seat appear perfectly familiar to us ; there are phenomena belonging to both, however, of which, I have no doubt, many are yet ignorant. That any circumstance of an interesting nature, should remain unobserved, can only be accounted for, by its being taken for granted, that these conspicuous objects, having already undergone much critical examination, nothing farther remains to be noticed. This is an opinion, which I shall prove in the sequel, to be without foundation.

Arthur's Seat and *Salisbury Craig*, are naturally the objects, which first attract the attention of the geological traveller, on his arrival in Edinburgh ; and to these places he is generally conducted by some one of our *amateurs*, when the favourite theory is introduced, and each corroborative fact dwelt upon, with all the usual keenness of theoretic discussion. This was the ground which, in all probability, first suggested the Theory of HUTTON ; and it was perhaps here, that his comprehensive mind originally laid the foundation, of the structure which he afterwards so successfully reared. But that theory, in itself so beautiful, and in many points so perfect, I am very far from embracing entirely. I am very far, indeed, from following him through his formation and consolidation of strata, or the transportation and arrangement of the materials, of which they are composed. There are other circumstances also, which, though totally irreconcilable with any other hypothesis, are yet but imperfectly explained by his. I particularly allude to the singular contortions, exhibited in what are termed *Transition strata*, so finely exemplified on the coast of Berwickshire. I wish to carry my inductions, just as far as facts will bear them out. It is therefore, only in the regions of unstratified rocks, or in their immediate vicinity, that I have as yet, been able to
discover

discover a language, which, if studied with due attention, cannot fail, I think, to become intelligible, and carry conviction to those, who choose to reason impartially on the subject.

IN the writings of Dr HUTTON, we do not meet with descriptions of particular districts, his object being rather to establish a general theory, by the particular facts which these districts afforded.

WE cannot, therefore, look to him for a mineralogical account of the neighbourhood of Edinburgh; and we have to regret, that no other geologist has yet undertaken that task.

IN a short notice, in the Appendix of a work on another county, by Professor JAMESON, this vicinity is mentioned as principally belonging, to what is termed the *Coal Formation* by WERNER, which, according to the system of that celebrated naturalist, forms part of the *Flötz* rocks.

To render these terms intelligible to the general reader, it is necessary to give some explanation, as, without a considerable knowledge of the system to which they exclusively belong, they must be totally incomprehensible.

WERNER is the only person, who has attempted a regular arrangement of rocks; an arduous undertaking, which I have no doubt he has accomplished, with all the accuracy the subject was susceptible of, and so far as the country he examined allowed*.

BUT it appears very evident, that the facts he met with were such, that, in consequence of the hypothesis he had previously thought proper to adopt, it became necessary to invent a theo-

* LINKS from other quarters, having been subsequently added to his formation-suites, by his pupils.

ry capable of embracing all the phenomena, which the construction of his systematic arrangement led him to observe. A peculiar language was therefore indispensable; and as this language has been constructed with so much regard to his theory, unless that is understood and adopted, his terms become useless.

By a *formation* is meant, any series or suite of rocks which usually occur together; hence the Coal Formation is composed of

- | | |
|-------------------------|-----------------------|
| 1. Sandstone, | 6. Limestone, |
| 2. Coarse Conglomerate, | 7. Marl, |
| 3. Slate-clay, | 8. Clay-ironstone, |
| 4. Bituminous Shale, | 9. Porphyritic Stone, |
| 5. Indurated Clay, | 10. Greenstone *, |

with which the Coal occurs in numerous beds, varying extremely in thickness. These, however, never all occur together, and it is no detriment to the Coal Formation suite, even if Coal itself should not be found among them.

AGAIN, the term *Fletz* is given to all the formations, contained between the transition and alluvial rocks, and implies that they are distinguished by their frequent occurrence in beds, which are much more nearly horizontal, than the primitive and
transition

* Greenstone is a literal translation from the German; it is an extremely improper name; but as we have no other by which we can distinguish this variety of trap, we must use it till a more appropriate is found, even at the expence of such language as *red and blue greenstones*. In the mean time, it must be understood merely as an arbitrary term.

transition rocks. If directly translated, the word signifies *flat*, and may be correctly descriptive of the districts originally examined by WERNER; but as this construction will not apply universally to this class of rocks, and as it is particularly at variance with those belonging to it in this country, it would be better to follow the example of Professor DAVY, and use the term *parallel rocks*, which is much less liable to objection.

THE Huttonian Theory has no language peculiar to itself, having nothing to describe, that cannot be done in the usual phraseology of any country. This, by the zealous admirers of that doctrine, may no doubt be lamented, as depriving it of an apparent systematic arrangement, to which the opposite theory is so deeply indebted.

IN forming a collection from the rocks in the neighbourhood of Edinburgh, the circumstances above narrated, induced me to begin with those of Salisbury Craig and its vicinity. The collection I have now the honour of presenting to the Society, I began some years ago: it is only part of a series, which, as completed, I hope may be found worthy of a place in their cabinet. I consider it of very great importance, that every geological paper, should be accompanied with specimens, in order that if the former be found deserving of publication in your *Transactions*, those who peruse the description may know, that the specimens referred to, are to be seen in the repositories of this establishment.

SALISBURY CRAIG is situated on the north side of Arthur's Seat, against which its southern extremity rests: from this it extends, in a northern direction, and rounds towards the east, so as to form the segment of a circle, about half a mile in length. It is surmounted by a magnificent façade, which is lowest at the extreme points; towards the middle, the perpendicular rock may be from 80 to 90 feet high. From the base of this precipice, a sloping bank, covered with debris, reaches to the valley below, altogether forming an elevation of nearly 400 feet. From the upper edge of it, a regularly inclined plane, slopes gently, on the opposite side, at an angle of about 15° , in a north-east direction, and forms the left bank of the valley, called the Hunters Bog. On the right of this valley, the rocks again rise rapidly, affording indications of two or three separate façades. These are not characterized in the distinct manner of Salisbury Craig, but are surmounted by a surface, which, though a little rounded, presents an inclination corresponding with that of the Craig, in a very striking manner.

FROM the base of Salisbury Craig, or rather from the base of the debris by which it is encircled, towards the southern extremity, the ground again rises, and presents an inclined plane, similar to its own, but of less magnitude. This is known by the name of St Leonard's Hill.

HENCE it appears, that there are three similarly inclined planes or terraces, of which Salisbury Craig forms the intermediate one, each of them having a different elevation. From this structure we may easily conceive the origin of the Swedish word *Trap*, which has been employed as a generic term, for the

the class of rocks to which this appearance may generally be attributed*.

If we imagine a vertical plane, to pass from St Leonard's Hill in an E. N. E. direction, which shall cut Salisbury Craig, and continue through the right bank of the Hunters Bog, we shall find the rocks disposed in the following manner :

St Leonard's Hill.

Sandstone.
 Porphyritic Greenstone.
 Sandstone.

Salisbury Craig.

Sandstone.
 Greenstone.
 Sandstone.

Hunters' Bog.

Greenstone.
 Sandstone.
 Porphyritic Greenstone.
 Trap-Tuff.
 Basalt.

The

* One of the greatest difficulties which geology as well as mineralogy has laboured under, is the multitude of synonymous terms which have been applied to every individual fossil. TRAP has suffered from this disadvantage, perhaps more than any other variety of rocks ; as above noticed, that name is derived from the similarity to the steps of a stair, which may generally be traced in the outline of a country, in which this rock abounds ; and as it has been employed as a generic term by mineralogists throughout Europe, I think it proper to use it, to the exclusion of *whinstone*, the name it bears in the writings of Dr HUTTON ;

The two last of these are not comprehended in the Coal Formation suite; they are considered as members of another formation, denominated the Newest Fløetz-Trap.

THE upper sandstone of St Leonard's Hill, and the lower sandstone of Salisbury Craig, are, so far as we know, continuous; but as these, supposing the lines of the strata to be projected, would form a bed of 450 feet thick, it is possible alternations of greenstone may occur in it. Above, I have only mentioned such as are visible.

THOSE on the right of the Hunters' Bog, are not so distinctly exposed as the rest; but the fossils are all found in the order I have stated. Occasionally small seams of reddish-brown coloured slaty clay, and clay-ironstone occur, principally intermixed with the sandstone; but they are so thin, and so unconnected, that they can scarcely be considered as strata.

THE series of specimens I am now about to describe, are those of St Leonard's Hill and Salisbury Craig.

No. 1. is a specimen of the Sandstone of St Leonard's Hill; it is of a reddish-white colour, and extremely coarse-grained. It was taken from the middle of the quarry, and presents a species of conglomerate, the fragments of sandstone being agglutinated by a dark-red ferruginous paste.

No. 2. from the same quarry, is more compact, and presents a streaked appearance, corresponding with the direction of the stratum. There is a considerable degree of irregularity to be observed, in tracing the line of junction at St Leonard's Hill. In some places, two or three folds of the strata are cut off abruptly

a name which, though perfectly understood in this country, is not received abroad, and ought therefore to be relinquished.

abruptly at each end by the greenstone; in another, that substance sinks suddenly as it were into a gap in the strata, and being lost in rubbish, has somewhat the appearance of a dike. Beyond this a double horizontal wedge of greenstone, with the ends turned downwards, appears among the strata; and a little farther, towards the north, a roundish mass of the same substance also occurs; this has very much the appearance of an included fragment, but the decomposition of the sandstone has just begun to expose its connection with the rock above.

ON the sandstone, Porphyritic Greenstone (No. 3.) rests. The colour of this is reddish-brown; the texture is fine-grained; and it contains small specks of flesh-coloured calcareous spar. It is traversed in various places by veins of Hematitic Iron-ore (No. 4.) accompanied with sulphate of barytes. These two specimens have very much the character of some varieties of porphyry-slate, and on breaking one mass, I observed a tendency to a slaty arrangement. In different places of this quarry, the greenstone assumes a variety of appearances (No. 5. and 6.), some of which might be attributed to decomposition. I do not conceive, however, that any external cause has ever had much effect upon this rock, although in some places it has entirely lost its lustre; (No. 7.), and might be mistaken for trap-tuff, were it not for the shape of the crystals.

ABOVE this, the rock graduates into a highly crystalline Porphyritic stone, (No. 8.) the paste of which is of a brownish-grey colour, very close-grained, with an uneven splintery fracture, containing both crystals of felspar and hornblende.

IN this quarry there are several instances of *slikensides*, one of which is rather remarkable, it occurs in an inclined rent in the sandstone: the traces of the slip, (No. 9.), are horizontal,

tal, and extremely well defined; but immediately over it, in the greenstone, the appearance of the slip is not continued. Some indications of a slip appear a little to the right of it.

IN a part of the Greenstone which is considerably decomposed, a vein, stretching horizontally, of a dark-green fibrous substance occurs, (No. 10.); it is soft, and has a shining fatiny lustre, like asbestos. I have not anywhere in this vicinity met with any similar substance.

WE now proceed to Salisbury Craig, where the circumstances I shall principally notice, are,

1. The texture of the greenstone rock, with the fossils it contains.
2. The vein of greenstone by which the Craig is intersected.
3. The included mass of sandstone which occurs in the greenstone; and,
4. The indurations and interruptions of the strata.

No. 11. is a specimen of the greenstone taken from the lower edge of the bed, at the great quarry, where it touches the sandstone; the point of contact being marked by a small remaining fragment of the latter, at which the grain of the stone is much finer than at the other extremity. The colour is iron-grey, with small specks of calcareous matter interspersed.

Nos. 12, 13, & 14. are different gradations of texture, taken in a vertical line, from the edge towards the centre, where the stone is always most perfectly crystallised; from hence it again declines in grain towards the upper surface, where we find it in the same earthy and uncrystallised state (No. 15.) observed at the bottom. In the last specimen, there is a small detached
fragment

fragment of the stratified matter imbedded in the greenstone, a circumstance connected with a very important class of facts.

No. 16. This specimen of greenstone is remarkable, as exhibiting a variety of colours; these are not blended, but distinctly divided from each other. The colours are iron-grey, light-grey, dark-red, and brick-red.

No. 17. This specimen is a strong example of the impropriety of the name which it bears; it is a greenstone, decidedly of a red colour. The singular penetration of ferruginous matter, which is exhibited in various parts of this rock, is not easily accounted for; but supposing it to have been once in a state of fusion, it may have obtained this superabundance of iron by absorption, as the adjoining strata frequently abound in that mineral.

In various parts of the Craig, veins of a peculiar nature may be observed; they are composed precisely of the same ingredients as the rock, and are distinguishable only by the red colour of the felspar, (No. 18). These are termed *contemporaneous veins*, or *veins of secretion*; they are deeply waved, and generally follow the direction of the bed. Some of them present a very bright brick-red colour, (No. 19.), mixed with specks of calcareous spar.

Nos. 20, 21. in these specimens, are small globules of a black earthy substance, which I am at a loss to name. I should have considered it Amphibole, but for the next specimen, (No. 22.), in which the same substance appears to occur in irregular fragments.

No. 23. Analcime with crystallised Calcareous Spar. I before noticed, that it was in the heart of the bed where the substance of the greenstone presented the crystalline texture in

the highest perfection. The occurrence of the analcime is connected with the same fact. I have never been able to find it on Salisbury Craig, excepting at one period, when an entire section of the bed was quarried off, and about the middle of this the analcime occurred.

No. 24. with fulphate of barytes, with calcareous sparry iron-ore.

No. 25. part of a very irregular vein. Its sides are formed of calcareous sparry iron-ore, which is followed by a coating of hematitic iron. Here the regular stratification, as it is called, of the vein ends, and calcedony, first semitransparent, then opaque, and common calcareous spar, occupy the rest.

No. 26. calcareous sparry iron-ore crystallised, with some transparent crystals of quartz.

No. 27. large crystals of calcareous spar, with crystallised and radiated tufts of quartz.

No. 28. red oxide of iron, with a vein of calcareous sparry iron-ore.

No. 29. green coloured quartz, with a coating of crystallised quartz.

No. 30. crystallised quartz, with amethyst.

SUCH are the minerals which occur on Salisbury Craig. Some of them are rare, and others to be found only when the rock is working in particular places.

THE next circumstance I have to notice, is the vein of greenstone*. It occurs a little to the north of the spot, to which

* The term *dyke* has been very generally applied to *veins* of this description, and I am not satisfied that it is the least proper of the two; as there certainly is a marked distinction between veins composed of rocks, and what we generally

which the cart-road, along the base of the rock extends, a few feet beyond a gap, known by the name of the *Cat's Nick*.

I do not think this vein attracted the attention of geologists in any particular manner, prior to 1805. It certainly was observed long before that period, but was not known to extend through the bed of greenstone, till Sir JAMES HALL and myself noticed, that after cutting the sandstone, it continued its course uninterrupted to the top. This observation contributed very much to increase our curiosity, and a man was employed to clear away the soil and rubbish, which had accumulated on the surface. A considerable portion of the rock was soon laid open, below the point from which it was at that time visible. Nothing, however, of much interest, was by this means discovered. The dike, after bending a little to one side, continued its course downwards.

THE space which this dike occupies, may be from six to eight feet wide; its width varies a little in some parts, and these variations are apparently increased, if the section which is observed be not at right angles with the walls. That portion embraced by the strata, which we found principally covered with debris, was very much decomposed, presenting on the surface a certain degree of nodular exfoliation, of a rusty-

3 G 2

brown

ly understand by mineral veins. The first are formed of one uniform rock, composed in all their parts of the same constituents, and differing only in position, from the beds these materials more usually form; while the latter, though sometimes formed only of one substance, such as quartz or calcareous spar, are generally composed of a series of fossils, arranged in lines parallel to the walls. No such appearance ever prevails in rock veins, or constituting mountain masses; therefore, in using the term *vein*, when applied to greenstone, granite, or the like, it must be understood as a generic term, of which these latter, specify the variety.

brown colour. On breaking into the rock, it exhibited (No. 31.)* the concentric lines so common in decomposing greenstone; and beyond this, the stone presented a degree of freshness, with a very coarse grain of a peculiarly light ash-grey colour, and a very dull earthy texture, (No. 32.) Between this portion of the vein and that embraced by the greenstone, there is a very remarkable difference, the latter being of the usual iron-grey colour, and otherwise perfectly characteristic. Before it leaves the sandstone strata, it seems to contain an unusually large proportion of calcareous matter. This may have aided the decomposition, together with the moisture retained by the debris, so lately removed from its surface, and which has left it in a state easily affected by the weather. Since I commenced writing this paper, I made an excursion to the spot, and was greatly surprised to observe the devastation of last winter.

Before the vein rises above the level of the strata, a portion of it, still more decomposed than the rest, of a dark-purple colour, branches off, and embraces a wedge-shaped mass of the sandstone (No. 33. and 34.) indurated in a very high degree. Just at the top of this indurated mass, the whole dike changes its colour, and, I may also say, its consistence. It here presents a light-greyish aspect, deeply stained, with red ferruginous marks, of a dull earthy texture, an even fracture, and a tolerably fine grain, (No. 35.) That portion corresponding with, and immediately over the included sandstone, I found much coarser in the grain, (No. 36.), and in a more decomposed state ;

* Corresponding numbers will be found in the annexed engraving, which will explain more fully the relative position of the specimens.

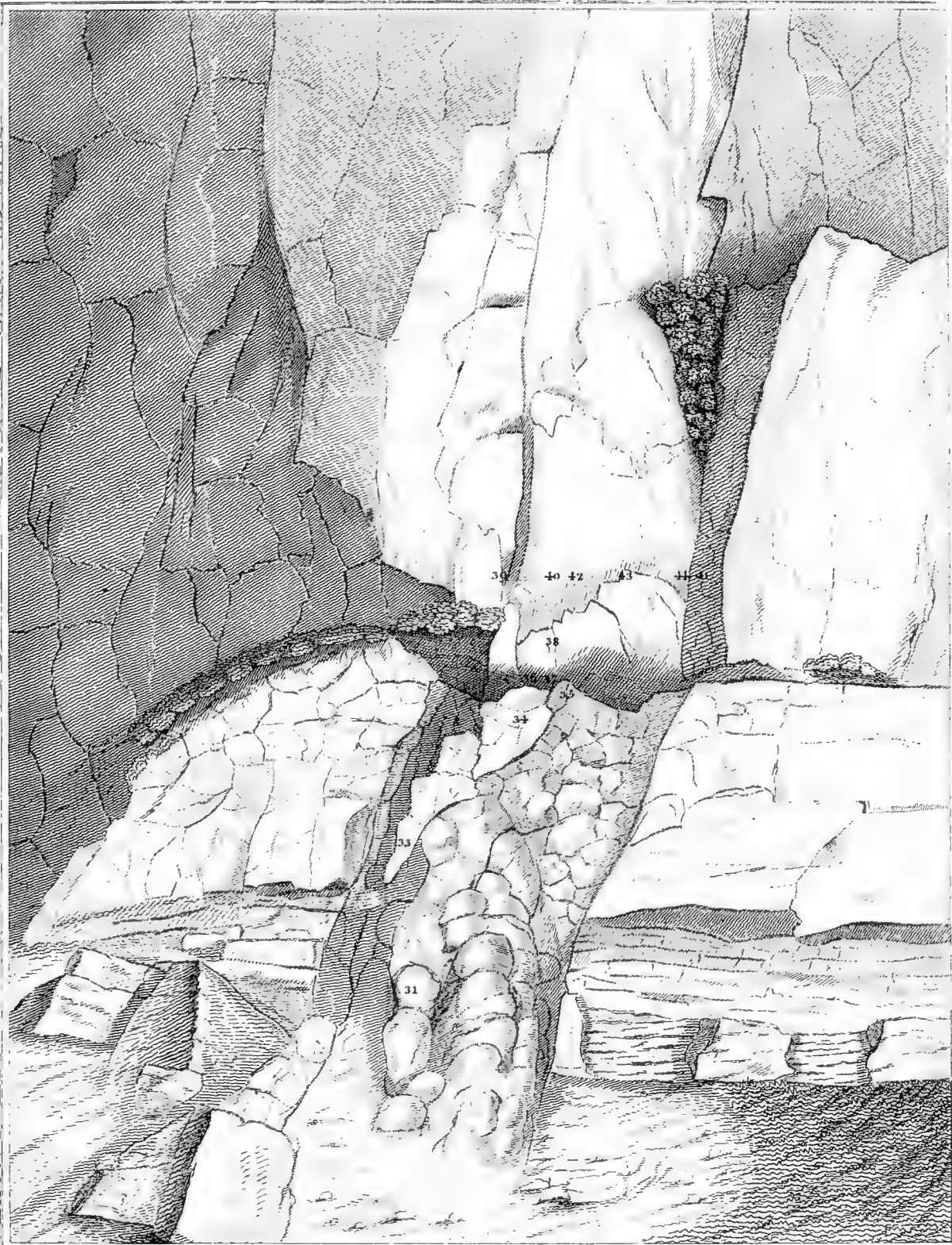



state; while it differed from No. 37., the stone on the sides, which were perfectly similar to each other in composition.

TRACING the friable purple-coloured portion upwards, I found it gradually became harder, and, of a sudden, change to a fine-grained blue-coloured greenstone; and the part corresponding with the included mass, alter to a hard coarse-grained rock, (No. 38.) I soon observed, that this coarse-grained mass, which is about ten inches thick, continued upwards, maintaining an uniform dimension and position, in respect to the walls of the vein, as high as the eye could trace it in the rock, thus dividing it into two portions; that on the left side being about eighteen inches wide, while the other is about five feet.

ON comparing the texture of the included stripe, with that of the walls on each side, (No. 39. left side; No. 40. included stripe; No. 41. right side,) taken in a horizontal line, about six feet above the strata, I found as close a resemblance as it is possible to conceive; they are all coarse-grained, and highly crystallised. This similarity is not more remarkable, than the difference between the substance of the vein and the included mass. Specimens taken from the junction of these, mark this in a striking manner. No. 42. is from the left side of the right portion of the vein, to which the fine-grained part belongs. No. 43. is from the middle of this portion; and No. 44. from the side next the right wall. These were also taken in a horizontal line, and exhibit the same gradation of grain noticed as existing in the great bed. Even in the narrow portion of eighteen inches, on the left side, this circumstance is quite visible; but the specimens taken from the other are highly illustrative of the fact.

I HAVE had an opportunity of examining many veins of greenstone; but I know of none more interesting in a geological point of view than this.

I THINK it can scarcely be doubted, that the same effort which separated the included portion of sandstone, cleft the corresponding stripe of greenstone from the great bed. This, as well as the gradation of grain, everywhere observable in beds and veins of trap, are remarks, in my opinion, of considerable value to the Huttonian hypothesis. On a former occasion, when I had the honour of submitting some remarks on the north of Ireland to the Society, I took an opportunity of dwelling particularly on the last circumstance. Like the charring of coal, when that substance is found in contact with whin, as has been ably remarked by Professor PLAYFAIR, "few facts in the history of fossils so directly assimilate the operations of the mineral regions with those which take place on the surface of the earth*." This gradation of texture has a strong analogy to many accidental facts observable in furnaces, of glasshouses and the like, and still more so to those experiments made expressly for the purpose of ascertaining the effects of slow cooling, by Sir JAMES HALL and others. One additional argument for the igneous origin of these veins, has been added by the observations of Sir GEORGE MACKENZIE and his friends, in Iceland, in perfect correspondence with the above fact. He there found many veins of this substance, coated on the sides with a glassy covering, exactly similar to melted greenstone, when rapidly cooled.

I SHOULD expect the same circumstance would be met with in veins of porphyry and granite; but I have not been able to extend

* Illustrations of the Huttonian Theory, § 68.

tend my observations so widely, as to embrace the facts respecting these rocks. One remark I shall, however, hazard in this place, respecting an essential difference between veins of granite and those of greenstone. The former seem to be of simultaneous formation with the great body of that rock, to which they may generally be traced, and, so far as I have hitherto observed, are never found to cut it. Veins of greenstone, on the other hand, I have never seen connected with the great beds of that substance; they traverse these just as they do every other kind of rock, and consequently are in all instances of a posterior formation. I am aware, that these ideas are very much at variance with certain received opinions. I therefore wish to be understood as speaking solely upon my own experience.

I HAVE now to mention the well-known included mass of sandstone. Along the edge of the strata, a number of instances occur on Salisbury Craig, affording the most unequivocal marks of disturbance; but it presents only one example, of a mass totally enveloped in the substance of the greenstone*.

THIS spot has been the scene of much controversy, between contending geologists. While the Huttonian considers it as a most incontrovertible proof of violence and of heat, the Wernerian contends, that there is nothing in the least extraordinary in the appearance, and asserts, that the superficies of the apparently included mass, is no more than the section of some part of the stratum, which, if traced, would be found to connect with the rest; that it had been enveloped in the fluid menstruum of the greenstone, when in this elevated position; and that the rock be-
ing

* Since this paper was sent to press, others have been observed in different parts of the rock.

ing cut in a certain direction, a section having the appearance of an insulated mass, would of course be exposed to view. There is no doubt that such a circumstance is perfectly possible; but, in the present instance, this explanation will not be found at all applicable. In every other case, where the strata appear displaced, they are not torn from the rest, nor has the greenstone insinuated itself, except as a wedge, supporting the lifted masses. The included mass is of a light greenish-grey colour, in shape quadrangular, and, when minutely examined, will be found shivered into numerous distinct fragments, with veins of greenstone running through it in every direction. It partly retains its original stratified texture (No. 45.) although indurated in a very high degree, and is so firmly welded to the greenstone, that it is no difficult matter to obtain specimens (No. 46.) of the conjoined rocks; one small specimen (No. 47.) in the collection, is twice intersected by that substance. It, therefore, has no resemblance whatever to those pieces of strata, which are only in part detached, and which, if cut in a transverse direction, would, in all probability, exhibit an insulated section. That section, however, would not display the broken and distorted appearance described above, at least if we may be allowed to judge by the integrity of the longitudinal sections, of which there are so many examples in this vicinity. Besides, the colour of the included mass is totally different from that of any of the strata near it, which are here of a deep red (No. 48.), and at this particular spot are remarkable for their apparent derangement. I therefore conclude, that there is every reason to consider this, as a fragment detached from some other part of the sandstone, and left suspended in its present situation, when the greenstone assumed a solid consistence, as was originally conjectured by Dr HUTTON.

I NOW come, as proposed, to that division of the subject which relates to indurations. By *induration* is meant, a greater degree of compactness, observable in particular parts of stratified rocks, than is usual throughout their mass. One part of a bed may be harder than another, consequently more indurated. But the induration here alluded to, is that which is supposed to have been effected, by an alteration in the density of the stone, in consequence of the action of heat.

THESE phenomena are of a very striking nature, and were first brought into notice by Dr HUTTON; in them, he found evidence, to him perfectly conclusive, of the igneous formation of whin, and, with that ingenuity and perseverance which characterise the whole of his works, he did not fail to generalise his observations, and to place the facts, first noticed in this spot, in such a light, as to render them essentially useful to his theory.

THE anxiety which the disciples of the Wernerian school have always evinced, to undervalue the merit of this observation, is a sure mark of the estimation in which they hold it; and it is, therefore, very properly considered by the supporters of the opposite doctrine, as one of their strongest holds. In the following list, are comprehended most of the varieties, which this indurated sandstone presents on Salisbury Craig.

No. 49. is a junction specimen*, taken near the southern extremity of the Craig; here the greenstone is of the deep red tinge noticed at No. 17.

VOL. VI. P. II.

3 H.

No.

* By *junction specimen* is meant, a specimen which exhibits the greenstone and the sandstone conjoined.

No. 50. is another specimen of the same kind; the greenstone is here of the usual colour, and the line of junction most admirably defined. This was taken from the great quarry. The next, (No. 51.), is a specimen of the sandstone in its supposed unaltered state. Nos. 49, and 50. are both from the lower junction. No. 52. is from the upper edge, taken about half-way between the highest part of the Craig and Holyroodhouse. Here the sandstone presents a faceted appearance, an arrangement which may be owing to the superabundance of calcareous matter.

No. 53. is highly indurated, of a deep red colour, with a conchoidal fracture, and a faceted texture.

No. 54. has the same faceted appearance.

No. 55., extremely close-grained, is from one of the contortions north of the dike.

Nos. 56, & 57. These are the varieties of the sandstone which have been called *jasper*. This is an improper name, as it confounds two substances totally different. The most compact contains a large proportion of lime, and in aspect is very similar to some of the limestones of Gibraltar.

Nos. 58, to 61. are varieties of the sandstone, found near the greenstone.

No. 62. Although this specimen was taken very near the greenstone, still it does not exhibit the usual induration. This exception occurs in different places on Salisbury Craig; and it even sometimes happens, that the stone next the whin is less indurated than the one below it.

No. 63. Containing a large proportion of ferruginous matter.

No. 64, to 66. Different shades and varieties of the sandstone, in an indurated state.

No.

No. 67. In this specimen there is something very like the appearance of an agate; it, however, is not contained in the substance of the greenstone, but in the stratified matter below it.

No. 68. Another specimen of the sandstone, in its unaltered state, taken about thirty feet from the greenstone.

DR HUTTON conceives, that the induration, so very remarkable in the above specimens, was occasioned by the heat of the whin, when it was injected between the strata of sandstone, causing it to undergo a certain degree of fusion; and, to this idea, the faceted texture of some of the specimens adds considerable weight, such arrangements being very familiar in stones which have undergone fusion.

THE Wernerian school, to account for the same phenomenon, asserts, that as sandstone is generally porous, the fluid solution of the trap being introduced into the fissure, naturally percolated to a greater or less extent*. Again, that it is owing to the intermixture of the matter of the vein, with the rock that forms its walls †; and, as a proof of this, it is added, that no induration appears, where the traversed rock is possessed of a quartz base.

THESE arguments occur in different works, but they appear to me very little calculated to support the point in dispute, if not in some respects contradictory. On Salisbury Craig, and generally throughout the neighbourhood of Edinburgh, wherever we find sandstone coming in contact with greenstone, either in beds or veins, we are almost certain, that an induration will be exhibited along the edge of the strata.

3 H 2

IT

* Comparative View of the Huttonian and Neptunian Theory, p. 130.

† System of Mineralogy, vol. iii. p. 365.

It has already been observed, that there are spots on Salisbury Craig, where this is not so apparent as in others, and it very often happens, that small seams of clay occur, in a perfectly soft state. In Ireland, at Scrabo, in the county of Down, and at Fairhead in that of Antrim, I found sandstone in the former, cut by veins, and in the latter, overlaid by a bed 300 feet thick, where no induration was to be seen. Now, it appears conclusive, that there could not have been a deficiency of induration in any speck of Salisbury Craig, far less a total absence, as in the cases quoted in Ireland, had it in any instance been effected either by percolation, or by the intermixture of the matter of the vein. The superincumbent or included matter, if in a fluid state, whatever its chemical powers were, would, to a certain extent, act mechanically, and be, in all circumstances, possessed of the same power of communicating its moisture to the surrounding masses. It is therefore impossible to conceive, how it should have withheld it in one instance, and parted with it so amply in another, how it should have indurated the sandstone, and left the thin seams of clay in a soft and friable state. It is quite unimportant, of what base the sandstone may be formed; it is a substance, allowed as above to be generally porous, (and, in the cases alluded to, it certainly was so); into that porosity, therefore, the fluid must have percolated, whatever the base may have been.

ON the contrary, according to the Huttonian hypothesis, induration distinctly depends, on the composition of the strata exposed to the influence of heat. Some strata may either wholly, or in part, be capable of resisting much higher temperatures than others. It is consequently to the ingredients of which they are formed, that we must look either for the cause of induration, or the absence of it. This remark originated in observing,

ſerving, that all the indurated ſandſtones of this country, contained more or leſs calcareous matter, while the unindurated ſpecimens from Ireland, did not afford the ſlighteſt indication of that ſubſtance, when ſubjected to the ſame teſt.

BEFORE I take leave of Salisbury Craig, I muſt notice one more circumſtance, which, ſo far as I have hitherto ſeen, is quite peculiar to the ſpot. I mean the occurrence, in veins, of a ſubſtance in all reſpects ſimilar to the indurated ſandſtones, I have juſt been deſcribing. The firſt of theſe I obſerved, is about thirty paces north of the vein. The ground being cut away, in order to ſee its connection with the ſtrata, it branched out like the prongs of a fork, and had the interſtice filled with a red decompoſed ſubſtance (No. 69.), ſimilar to that which occurred at the extremity of the included ſtripe of greenſtone in the vein. Where the prongs join, it is about three or four inches wide, and is there, partly compoſed of indurated ſandſtone, and partly of hematitic iron-ore and calcareous ſpar. (No. 70.) Higher up, where the vein is narrower, it is wholly compoſed of ſandſtone, the ſpecimen, No. 71., being the entire thickneſs of it. - Here the grain is finer than at firſt, and, higher up, it becomes ſtill more ſo, (No. 72.) It ſtill continues to taper upwards, and even when reduced to leſs than half an inch, the ſubſtance retains the uſual aſpect of indurated ſandſtone, (No. 73.) This vein riſes about twenty to thirty feet into the rock, always diminiſhing, and about that height diſappears. I have remarked other veins, alſo containing ſubſtances ſimilar to indurated ſandſtone (No. 74.), one was of a much larger ſize than that above deſcribed (No. 75.), but the grain not near ſo compact, (No. 76.)

THESE veins all ſet off from the lower ſurface, and ſo long as they are of any conſiderable thickneſs, the including rock is ſtained

stained with ferruginous matter. This fact seems connected with the singular appearances, which occur in the vein of greenstone, at the level of the junction of the sandstone strata with the incumbent bed.

WITHOUT offering any remarks on a fact as yet so insulated, I content myself with merely mentioning it, in hopes that similar appearances may present themselves to geologists in other quarters, and perhaps throw some light on a phenomenon, which by farther elucidation may prove interesting.

BEFORE I close this paper, I shall take the opportunity of presenting to the Society, two specimens which were given to me by Sir GEORGE MACKENZIE, and which I esteem of considerable value; one of them, a fragment of the rock of Salisbury Craig; the other, of the Calton Hill, marked in the handwriting of the late Dr KENNEDY, as the substances he analysed, and of which an account was given in the 5th volume of these *Transactions*. The great variety in the rock, both of Salisbury Craig and Calton Hill, makes it of importance to ascertain with precision the kind employed in the research of that celebrated chemist; and as the most proper place for their reception, I deposite them in the cabinet of this Society, along with my own collection, under the Nos. 77, and 78.

19th March.

SINCE I had the honour of reading the foregoing paper to the Society, a strong case in illustration of what is mentioned in the commencement of it, has presented itself; I mean, with respect to the constant occurrence of new and interesting matter, even in the most frequented ground.

A FEW days ago, Professor PLAYFAIR mentioned to me, that by the cutting down of a section of the Craig, within thirty paces of the southern extremity, several masses of sandstone had made their appearance, imbedded in the greenstone. I lost no time in visiting the spot, and was greatly pleased to find, a considerable addition to the interesting facts, already exhibited on Salisbury Craig.

AT this part of the rock, the greenstone becomes very thin, being no more than twenty to twenty-five feet thick; it has the appearance, however, of having once been of greater extent, the upper part being apparently cut away by some operation of nature, of which we have now only to observe the effects. It slopes rapidly towards the south, and is covered to a considerable depth with soil and travelled stones. It is at the upper surface of this, that the imbedded masses occur; they appear to be portions of strata, which observe the general inclination of the sandstone of Salisbury Craig, that is, dipping towards the north-east, while the exposed sections are parallel to each other, and nearly horizontal; consequently, being near the surface, they are cut off, or crop out, on the south side. Their appearance,

appearance, however, bespeaks their having been, at some former period, totally included in the greenstone. One mass, indeed, a little towards the north, is unequivocally so; at least we know with certainty, that a short time ago it was inclosed in the greenstone, and not to be seen; and there is at present, great apparent probability, that the next section taken from the same part of the rock, will carry it away altogether.

TILL now, we only knew of one included mass in the greenstone of Salisbury Craig; and with this, these now discovered have considerable analogy; they are of the same colour, and although they appear to be only four or five distinct masses, these masses are all intersected vertically and diagonally, and are split through the whole length of the horizontal line; so that in examining a section of about ten feet perpendicular, no less than nine different alternations of sandstone may be reckoned. Some of them are no doubt very minute; but still they were all observable when I examined the rock.

FROM the most northern mass of included sandstone, I was enabled to procure a few specimens, which I have added to the above collection. The rock rises so rapidly from the south, that although this mass is nearly in the same horizontal line with the others, all of which crop out to the surface, and although it is not distant more than four or five yards, yet it appears to be situated nearly about the middle, between the sandstone and the upper surface, from which it may naturally be inferred, that the masses which now crop out, were like this, once entirely included in the substance of the greenstone. It is highly indurated, and at the extremities, is drawn out into minute veins. The thickness of the principal mass may be from ten to twelve inches, and in length from six to eight feet. This body, as above noticed, is cut in all directions by the greenstone.

greenstone. The specimen No. 79. shews a portion of the sandstone, with that substance traversing its stratified lines diagonally. No. 80. is a mass of the sandstone, containing a small portion of greenstone, much of the same shape as the double wedge of St Leonard's Hill, and formed, as I conceive, exactly in the same manner. This wedge, on one side of the specimen, is two inches long, but, on the opposite, it is not one; and in the counter part of the same specimen, (No. 81.) it is only to be seen on one surface; it does not penetrate to the other side, though scarcely an inch thick.

I AM glad to find, that interest has been made to prevent this valuable set of facts from being soon destroyed, as, in a few weeks, the rock in which these are contained would have been broken down, and carried off for the repair of the neighbouring roads.

IT is on this account, that much activity is requisite to keep these perishable phenomena from being lost, in the neighbourhood of such a town as Edinburgh. Similar things are presenting themselves constantly, but they are opened only for a day, and if not seized and recorded on the instant, will be shut up, and lost for ever.

END OF THE SIXTH VOLUME.

The first part of the book is devoted to a general survey of the history of the subject. It begins with a discussion of the early attempts to explain the origin of life, and then proceeds to a more detailed account of the development of the theory of evolution. The author discusses the work of Darwin and Wallace, and the evidence in support of their theory. He also discusses the work of other scientists who have contributed to the study of evolution, and the current state of the theory.

The second part of the book is devoted to a detailed account of the development of the theory of evolution. It begins with a discussion of the work of Darwin and Wallace, and the evidence in support of their theory. It then discusses the work of other scientists who have contributed to the study of evolution, and the current state of the theory.

DIRECTIONS TO THE BINDER.

The sheets marked a and b, containing the History of the Society and the Laws, to be placed in front of the volume, immediately after the general title-page and general table of Contents.

The temporary title-pages and tables of Contents for Parts I. and II. to be cancelled, as now unnecessary.

The last leaf of signature 3 D, pp. 390, 400, and the first leaf of 3 E, pp. 401, 402, are to be cancelled, and two new leaves substituted.

Plate I. fronting p. 18.

— II. and III. fronting p. 70.

Sir JAMES HALL'S Plates, marked with small numerals, Pl. I, II, III, IV, v. to front p. 186.

Plates VI, and VII. fronting p. 244.

— VIII. - - 248.

— IX. - - 344.

— X. - - 376.

— XI. - - 402.

— XII. - - 420.

* * The Binder will take notice that the Plates must fold out.

1911

THE UNIVERSITY OF CHICAGO
DEPARTMENT OF HISTORY

MEMORANDUM

TO THE DEPARTMENT OF HISTORY

FROM [Name]

SUBJECT: [Topic]



THE UNIVERSITY OF CHICAGO

