



FOR THE PEOPLE  
FOR EDUCATION  
FOR SCIENCE

LIBRARY  
OF  
THE AMERICAN MUSEUM  
OF  
NATURAL HISTORY









MEMOIRS AND PROCEEDINGS

587 (42.02) 2n2

ck

OF THE

MANCHESTER

LITERARY & PHILOSOPHICAL

SOCIETY.

(*MANCHESTER MEMOIRS.*)

VOLUME LVIII. (1913-14.)

MANCHESTER :  
36, GEORGE STREET.

1915.





## NOTE.

---

The authors of the several papers contained in this volume are themselves accountable for all the statements and reasonings which they have offered. In these particulars the Society must not be considered as in any way responsible.



# CONTENTS.

## INAUGURAL ADDRESS.

- The Old Manchester Natural History Society and its Museum.  
By the President, FRANCIS NICHOLSON, F.Z.S. ... pp. 1—15  
*(Issued separately, December 2nd, 1913.)*

## MEMOIRS.

- I. Changes in the branchial lamellae of *Ligia oceanica*, after prolonged immersion in fresh and salt water. By DOROTHY A. STEWART, B.Sc. *With 2 Pls.* ... pp. 1—12  
*(Issued separately, December 31st, 1913.)*
- II. Note on some products isolated from Soil. By Professor EDMUND KNECHT, Ph.D., and EVA HIBBERT, Assoc. M.S.T. ... pp. 1—5  
*(Issued separately, December 17th, 1913.)*
- III. The Willow Titmouse in Lancashire and Cheshire. By T. A. COWARD, F.Z.S., F.E.S. ... pp. 1—8  
*(Issued separately, March 27th, 1914.)*
- IV. Observations on the Homopterous Insect *Phrommia (Flata) marginella* Oliv. in the Himalayas. By A. D. IMMS, M.A., D.Sc. *With 2 Pls. and 1 Text-fig.* ... pp. 1—12  
*(Issued separately, April 15th, 1914.)*
- V. The Specification of the Elements of Stress. Part III. The definition of the dynamical specification and a test of the elastic specification. A chapter in Elasticity. By R. F. GWYTHER, M.A. ... pp. 1—21  
*(Issued separately, May 10th, 1914.)*
- VI. How does the Plant obtain its nutriment from the Soil? By A. D. HALL, M.A., F.R.S. *With 6 Pls. and 1 Text-fig.* ... pp. 1—22  
*(Issued separately, May 25th, 1914.)*

- VII. Some Notes on the Measurement of Air Velocities, Pressures, and Volumes. By WILLIAM CRAMP, M.I.E.E., M.Sc.Tech. *With 5 Text-figs.* ... .. pp. 1—16  
(Issued separately, May 26th, 1914.)
- VIII. Faunal Survey of Rostherne Mere. I. Introduction and Methods. By W. M. TATTERSALL, D.Sc., and T. A. COWARD, F.Z.S., F.E.S. *With 1 Pl. and 1 Map* ... pp. 1—21  
(Issued separately, May 30th, 1914.)
- IX. Faunal Survey of Rostherne Mere. II. Vertebrata. By T. A. COWARD, F.Z.S., F.E.S. ... .. pp. 1—37  
(Issued separately, May 30th, 1914.)
- X. Carbon: its molecular structure and mode of oxidation. By MAURICE COPISAROW, B.Sc. *With 6 Text-figs.* ... pp. 1—11  
(Issued separately, May 22nd, 1914.)
- XI. Note on the Intrinsic Field of a Magnet. By J. R. ASHWORTH, D.Sc. ... .. pp. 1—6  
(Issued separately, July 2nd, 1914.)
- XII. The Specification of Stress. Part IV. The Elastic Solution: The Elastic Stress relations and conditions of Stability: Struts, ties and test-pieces. By R. F. GWYTHER, M.A. pp. 1—9  
(Issued separately, September 19th, 1914.)
- XIII. Faunal Survey of Rostherne. III. Preliminary List of Lepidoptera found round the Mere. By A. W. BOYD, M.A., F.E.S. ... .. pp. 1—12  
(Issued separately, June 19th, 1914.)
- XIV. Juvenile Flowering in *Eucalyptus globulus*. By Professor F. E. WEISS, D.Sc., F.L.S. *With 2 Pls.* ... .. pp. 1—4  
(Issued separately, October 31st, 1914.)
- XV. Quantitative Absorption Spectra. Part I. The chemical significance of absorption spectra and the methods of examining them. By F. R. LANKSHEAR, B.A., M.Sc. *With 2 Text-figs.* ... .. pp. 1—12  
(Issued separately, October 16th, 1914.)

|  |  |
|--|--|
| PROCEEDINGS ... ..   | i.—lxxii.                                  |
| General Meetings ... ..  | iv., xiii., xiv., xvi., xviii., xx., xxiv. |
| Special Meeting ... ..   | xxiii.                                     |
| Annual General Meeting ... ..  | xxvi.                                      |
| Report of Council, 1914, with obituary notices of Professor Paul F. Ascherson, The Rt. Hon. Lord Avebury, D.C.L., F.R.S., Sir William H. Bailey, M.I.Mech.E., F.R.G.S., Mr. Walter L. Behrens, Mr. Henry Brogden, F.G.S., M.I.Mech.E., Mr. Robert Cotton, M.Sc., Mr. William H. Johnson, B.Sc., Sir John Murray, K.C.B., Sc.D., F.R.S., Professor John T. Nicolson, D.Sc., Mr. William H. Sutcliffe, F.G.S., and Mr. Thomas Thorp, F.R.A.S. ... .. | xxix.—xlix.                                |
| Treasurer's Accounts... ..   | l.—lii.                                    |
| List of the Council and Members of the Society ... ..  | liii.—lviii.                               |
| List of the Awards of the Dalton Medal ... ..  | lviii.                                     |
| List of the Wilde Lectures ... ..  | lxix.—lxx.                                 |
| List of the Special Lectures .. ..   | lxx.                                       |
| List of the Presidents of the Society ... ..   | lxxi.—lxxii.                               |

---

## INDEX.

M=Memoirs. P=Proceedings.

- Accessions to Library. P. i., v., vii., x., xv., xvi., xviii., xxi., xxiii., xxvii., xxviii.
- Adamson, R. S. Obituary notice of P. F. Ascherson. P. xxxii.
- Annual General Meeting. P. xxvi.
- Annual Report. P. xxix.
- Ascherson, P. F. Obituary notice of. By R. S. A. P. xxxii.
- Ashworth, J. R. Note on the Intrinsic Field of a Magnet. M. 11. P. xxviii.
- Atom, The Structure of the. By Sir E. Rutherford. P. x.
- Auditors. P. xvii.
- Avebury, Lord, Obituary Notice of. By G. H. P. xxxiii.
- Bailey, Sir W. H., Reference to the death of. By F. E. Weiss. P. x.  
— Obituary notice of. By C. L. B. P. xxxv.
- Bakelite, Exhibition of. By W. W. Haldane Gee. P. xiii.
- Barnes, C. L. Exhibition of small prayer roll. P. v.  
— Obituary notice of Sir W. H. Bailey. P. xxxv.  
— Plane trees and pulmonary troubles. P. xxvii.
- Behrens, W. L. Obituary notice of. By W. B. P. xxxvii.
- Bleaching Agents, The Action of, on various Natural Colouring Matters. By R. L. Taylor. P. xiii.
- Boyd, A. W. Faunal Survey of Rostherne. Part III. Preliminary List of Lepidoptera found round the Mere. M. 13. P. xxiv.
- Brabbée Tube, Exhibition of. By W. Cramp. P. iii.
- Bragg, W. H. Crystalline structure as revealed by X-rays. P. xxiii.
- Brogden, H. Obituary notice of. By F. N. P. xxxviii.
- Burton, W. Obituary notice of W. L. Behrens. P. xxxvii.
- Carbon: its molecular structure and mode of oxidation. By M. Copisarow. M. 10. P. xvii. and xviii.
- Carpenter, H. C. H. The crystallising properties of electro-deposited Iron. P. vi.
- Changes in the branchial lamellae of *Ligia oceanica*... By D. A. Stewart. M. 1. P. iv.
- Controversies concerning...the Dawn-Man found near Piltown. By G. Elliot Smith. P. vii.

- Copisarow, M. Carbon: its molecular structure and mode of oxidation. M. 10. P. xvii. and xviii.
- Cotton, R. Obituary notice of. By G. H. P. xxxix.
- Coward, T. A. Exhibition of Peacock butterfly, *Tanessa io*. P. xvi.
- Faunal Survey of Rostherne Mere. Part II. Vertebrata. M. 9. P. xxiv.
- The Willow Titmouse in Lancashire and Cheshire. M. 3. P. xvi.
- See Tattersall, W. M.
- Cramp, W. Exhibition of a Brabbée Tube. P. iii.
- Some notes on the measurement of air velocities, pressures and volumes. M. 7. P. xv.
- Crystalline structure as revealed by X-rays. By W. H. Bragg. P. xxiii.
- Dawn-Man Controversies. By G. Elliot Smith. P. vii.
- Election of Ordinary Members. P. iv., xiii., xiv., xvi., xviii., xx., xxiv.
- Electro-deposited Iron, The crystallising properties of. By H. C. H. Carpenter. P. vi.
- Elliot Smith, G. See Smith, G. Elliot.
- Eucalyptus globulus*, Juvenile Flowering in. By F. E. Weiss. M. 14. P. iii.
- Faunal Survey of Rostherne Mere. Part I. By W. M. Tattersall and T. A. Coward. M. 8. P. xxiv. Part II. Vertebrata. By T. A. Coward. M. 9. P. xxiv. Part III. Preliminary List of Lepidoptera found round the Mere. By A. W. Boyd. M. 13. P. xxiv. Part IV. Preliminary account of the Flora. By R. S. Adamson. P. xxiv.
- Gee, W. W. Haldane Exhibition of Bakelite. P. xiii.
- Grummitt, W. C. and Hickling, G. A Preliminary Note on the Structure of Coal. P. xxv.
- Gwyther, R. F. The Specification of the elements of Stress. Part III. The definition of the dynamical specification and a test of the elastic specification. A chapter on elasticity. M. 5. P. xvii.
- The Specification of Stress. Part IV. The Elastic Solution: The Elastic Stress relations and conditions of Stability: Struts, ties and test-pieces. M. 12. P. xxiii.
- The Specification of Stress. Part V. An outline of the theory of Hyper-elastic Stress. P. xxvii.
- Hall, A. D. How does the Plant obtain its nutriment from the soil? M. 6.
- Hibbert, E. See Knecht, E.

- Hickling, G. Exhibition of a series of Old Red Sandstone Fish. P. iv.  
 — Obituary notice of Lord Avebury. P. xxxiii.  
 — Obituary notice of R. Cotton. P. xxxix.  
 — See Grummitt, W. C.
- Hinson, R. F. Obituary notice of W. H. Johnson. P. xl.
- How does the Plant obtain its nutriment from the soil? By A. D. Hall.  
 M. 6.
- Hoyle, W. E. Obituary notice of *Sir* John Murray. P. xl.
- Hubrecht, J. B. Studies in Solar Rotation. P. six.
- Imms, A. D. Observations on the Homopterous Insect *Phrommia (Flata)*  
*marginella* Oliv. in the Himalayas. M. 4. P. xvi.
- Inaugural Address. See Nicholson, F.
- Johnson, W. H. Reference to the death of. P. xviii.  
 — Obituary notice of. By R. F. II. P. xl.
- Juvenile Flowering in *Eucalyptus globulus*. By F. E. Weiss. M. 14. P. iii.
- Knecht, E. and Hibbert, E. Note on some products isolated from Soot.  
 M. 2. P. vi.  
 — — — On l-pimaric acid from French rosin. P. xvii.
- Lankshear, F. R. Quantitative Absorption Spectra. Part I. The chemical  
 significance of absorption spectra and the methods of examining them.  
 M. 15. P. xxviii.
- Library Accessions. P. i., v., vii., x., xv., xvi., xviii., xxi., xxiii., xxvii.,  
 xxviii.
- Ligia oceanica*, changes in the branchial lamellae... By D. A. Stewart.  
 M. 1. P. iv.
- Loewenfeld, K. Exhibition of Saphiringlass. P. xiii.
- L-pimaric acid from French rosin. By E. Knecht and E. Hibbert. P. xxii.
- Lubbock, *Sir* J. See Avebury.
- Makower, W. See Walmsley, H. P.
- Manchester Natural History Society and its Museum, The Old. By  
 F. Nicholson. Inaugural Address. P. iii.
- Members, Election of Ordinary. P. iv., xiii., xiv., xvi., xviii., xx., xxiv.
- Mercury, Film of. By T. Thorp. P. xvii.
- Murray, *Sir* John. Obituary notice of. By W. E. H. P. xl.



- Nicholson, F. Obituary notice of H. Brogden. P. xxxviii.  
 — President's thanks. P. iii.  
 — Reference to the death of Mr. W. H. Johnson. P. xviii.  
 — Reference to the death of Mr. W. H. Sutcliffe. P. v.  
 — Remarks on Wheat Ears. P. iii.  
 — Remarks upon some Poisonous Plants. P. v.  
 — The Old Manchester Natural History Society and its Museum.  
 Inaugural Address and P. iii.
- Nicolson, J. T. Obituary notice of. By E. R. P. xliii.
- Note on some products isolated from Soot. By E. Knecht and E. Hilbert.  
 M. 2. P. vi.
- Note on the Intrinsic Field of a Magnet. By J. R. Ashworth. M. 11.  
 P. xxviii.
- Obituary notices.—P. F. Ascherson, P. xxxii. Lord Avelbury, P. xxxiii.  
 Sir William H. Bailey, P. xxxv. W. L. Beluens, p. xxxvii. H.  
 Brogden, P. xxxviii. R. Cotton, P. xxxix. W. H. Johnson, P. xl.  
 Sir John Murray, P. xl. J. T. Nicolson, P. xliii. W. H. Sut-  
 cliffe, P. xlvi. T. Thorp, P. xlvi.
- Observations on the Homopterous Insect *Phromnia (Flata) marginella*  
 Oliv. in the Himalayas. By A. D. Imms. M. 4. P. xvi.
- Officers, Election of. P. xxvi.
- Old Red Sandstone Fish, Exhibition of a Series of. By G. Hickling. P. iv.
- Peacock butterfly, Exhibition of. By T. A. Coward. P. xvi.
- Photographic Action of  $\alpha$ -rays, The. By H. P. Walmsley and W. Makower.  
 P. xxvii.
- Phromnia (Flata) marginella* Oliv. in the Himalayas. By A. D. Imms.  
 M. 4. P. xvi.
- Piltown skull, Controversies. By G. Elliot Smith. P. vii.  
 — —, Photographs of. By G. Elliot Smith. P. xv.
- Plane trees and pulmonary troubles. By C. L. Barnes. P. xxvii.
- Poisonous plants, Some remarks upon. By F. Nicholson. P. v.
- Prayer roll, Exhibition of. By C. L. Barnes. P. v.
- Preliminary Note on the Structure of Coal. By W. C. Grummitt and  
 G. Hickling. P. xxv.
- Quantitative Absorption Spectra. Part I. By F. R. Lankshear. M. 15.  
 P. xxviii.
- Rostherne Mere, See Faunal Survey of.
- Rutherford, Sir E. Obituary notice of. J. T. Nicolson. P. xliii.  
 — The Structure of the Atom. P. x.

- Salt, Exhibition of a fused mass of. By G. P. Varley. P. v.
- Saphiringlass, Exhibition of. By K. Loewenfeld. P. xiii.
- Smith, G. Elliot. The Controversies concerning the Interpretation and Meaning of the Remains of the Dawn-Man found near Piltown. P. vii.
- Photographs of the Piltown skull. P. xv.
- Some notes on the measurement of air velocities, pressures and volumes. By W. Cramp. M. 7. P. xv.
- Specification of Stress. By R. F. Gwyther. Part III., M. 5. P. xvii. Part IV., M. 12. P. xxiii. Part V., P. xxvii.
- Stewart, D. A. Changes in the branchial lamellae of *Ligia oceanica*, after prolonged immersion in fresh and salt water. M. 1. P. iv.
- Stress, Specification of. By R. F. Gwyther. Part III., M. 5. P. xvii. Part IV., M. 12. P. xxiii., P. V., P. xxvii.
- Stromeyer, C. E. Note on anagrams. P. xxi.
- Structure of the Atom, The. By Sir E. Rutherford. P. x.
- Studies in Solar Rotation. By J. B. Hubrecht. P. xix.
- Sutcliffe, W. H. Reference to the death of. P. v.
- Obituary notice of. By F. E. W. P. xlvi.
- Tattersall, W. M. and Coward, T. A. Faunal Survey of Rostherne Mere. Part I. Introduction and Methods. M. 8. P. xxiv.
- Taylor, R. L. The Action of Bleaching Agents on various Natural Colouring Matters. P. xiii.
- Thorp, T. Experiment on the pressure required to obtain a film of mercury. P. xvii.
- Obituary notice of. By W. H. T. P. xlvii.
- Todd, W. H. Obituary notice of T. Thorp. P. xlvii.
- Tanessa io*, Exhibition of. By T. A. Coward. P. xvi.
- Varley, G. P. Exhibition of a fused mass of salt. P. v.
- Walmsley, H. P. and Makower, W. The Photographic Action of  $\alpha$ -rays. P. xxvii.
- Weiss, F. E. Juvenile Flowering in *Eucalyptus globulus*. M. 14. P. iii.
- Obituary notice of W. H. Sutcliffe. P. xlvi.
- Reference to the death of Sir W. H. Bailey. P. x.
- Wheat-Ears, Remarks on. By F. Nicholson. P. iii.
- Willow Titmouse in Lancashire and Cheshire, The. By T. A. Coward. M. 3. P. xvi.

## INAUGURAL ADDRESS.

The Old Manchester Natural History Society and  
its Museum.

By THE PRESIDENT,

FRANCIS NICHOLSON, F.Z.S.

*October 7th, 1913.*

The Manchester Natural History Society existed from 1821 to 1858. Throughout its career its principal work was the formation and maintenance of a natural history museum in Manchester.

The formation of the Society was suggested primarily as a means of keeping intact the fine private collection of birds, insects and minerals got together by John Leigh Philips, sold at his sale in 1815, and in 1821 possessed by Thomas Henry Robinson. The Society was formed on 30th June, 1821. At the beginning its members, or proprietors as they were called, subscribed £10 as an entrance fee, and paid an annual subscription of a guinea. Minor changes were made from time to time in these conditions, and at one period the annual subscription was two guineas, and at another a guinea and a half. For only a few years was the annual income of the Society equal to its necessary expenditure, and on several occasions proposals were made for union with other Manchester societies: in 1822 with the Literary and Philosophical Society, and in 1824 and again in 1826 with the Royal Institution. In 1856 the question of selling the property was considered, and in 1865 the Museum was offered to the Manchester Corporation. It was refused, the sapient Corporation not agreeing with the Society's condition that the Committee of Management should include some persons interested in

*December 2nd, 1913.*

science as well as representatives of the Corporation. What the Manchester Corporation refused was sought by the Salford Corporation shortly afterwards, but there were some technical difficulties in the way.

In 1866 began the negotiations which resulted in the Museum being transferred to the Owens College. At that time the Society had the choice of several schemes—(1) to sell part of the property and collections, move into smaller rooms, and perhaps join the Literary and Philosophical Society; (2) to accept the offer made by the Salford Corporation to take the Museum on the same terms as were refused by the Manchester Corporation; (3) to divide the collection amongst neighbouring museums and societies; (4) to hand the Museum and funds over to the Owens College. The last plan was adopted. The details finally settled were that the property of the Society should be conveyed to the Owens College in trust, charged with the payment of the liabilities of the Society, £5,000 for the Building Fund of the College, £1,500 to the Literary and Philosophical Society for the promotion of the study of natural history in Manchester, and the balance was to be an endowment for the Museum. There were unavailing protests by E. W. Binney and others against the transfer.

The Museum was first housed in rooms in St. Ann's Place from 1821 to 1824, when it was removed to rooms in King Street, in a building where the Reform Club now stands. In 1835 it was transferred to a more permanent home, a building erected for the purpose on land in Peter Street and Mount Street, where the Y.M.C.A. now stands. In this building, which was enlarged in 1850, it remained until the Society's dissolution. The Museum was opened there on May 18th, 1835.

In its early days the Museum was a private institution for the use of its proprietors, who were allowed to give a

written invitation to their friends to inspect the treasures. In 1826 a general invitation to visit the Museum was given to the officers of the troops stationed in Manchester.

In 1837 the Governors declined by a majority of two to one to adopt rules which would have allowed the general public to be admitted to the Museum on payment of one shilling, and gratuitously on certain occasions. In the same year Dr. J. E. Gray, of the British Museum, commented unfavourably on the exclusiveness of the proprietors of the Manchester Museum, which stood alone among provincial museums in entirely excluding non-members.

Specimens were not lent out, a reasonable precaution which was taken even when men of the scientific eminence of Professor Phillips and Dr. Hibbert Ware asked for loans for scientific purposes, but drawings of specimens were allowed to be made for Swainson's "Encyclopedia of Natural History."

In 1838 the Society relaxed its exclusiveness by admitting non-subscribers to the Museum on payment of one shilling each, schools on payment of threepence for each scholar, and members of the working classes on payment of sixpence each.

In 1840, on the occasion of Queen Victoria's marriage, some gentlemen paid £10 in order that the Museum might be opened free from 11 to 4. As a mark of appreciation for their management of the crowd on the same auspicious occasion the Chief of Police and his men, in bands of twenty, were given free admission. The annual income of the Society, including admission fees, was, in 1831-2, £630; 1832-3, £594; 1833-4, £621; 1834-5, £492; 1835-6, £934; 1836-7, £928; 1837-8, £1,322; 1838 (7 months), £821; 1838-9, £996; 1839-40, £847; 1840-1, £784. On this income there was a charge for interest on the loans out of which the Museum had been

built, and the cost of the curator's salary and of general maintenance had to be met.

The subscriptions showed a general tendency to shrink, and as old members died or resigned there was difficulty in replacing them. While this process was going on the use of the Museum by the general public was increasing. In 1863, when the public were admitted at one shilling and working people at threepence, and the price of tickets on Saturday was only twopence, the income from casual visitors was £128 11s. 1d., while the subscription income of £360 18s. 9d. was much less than half of the subscription income in the Society's palmy days.

In 1853, when a request for the free admission of the Owens College men was made to the Council, they were offered non-transferable tickets at five shillings per annum, an offer which was accepted.

The curators of the Museum were all men of distinction. The first curator was W. C. Williamson, appointed in 1835, shortly after the removal to Peter Street. Mr. Williamson was, of course, a very young man at this time. In later years he attained great distinction as a scientific man, and there is a long and appreciative notice of him in the "Dictionary of National Biography."

The next curator, appointed in 1839, was Captain Thomas Brown, a good all-round naturalist for those days, with a specialist's knowledge of conchology, fossil and recent. On conchology he produced several important works. He wrote a number of popular books on natural history; he was author of a "Taxidermist's Manual" which passed through twenty-one editions, and he edited one of the better editions of White's "Selborne." He was born at Perth in 1785, and owed his title of Captain to the position he had held in the Forfar and Kincardine Militia. His regiment was at one time stationed in Manchester, a fact

which perhaps accounts for his subsequent connection with the town. When his regiment was disbanded he invested his money in a flax mill, which was burnt down, uninsured. Afterwards he made a living as a scientific author until he became curator at Manchester.

Captain Brown was a man well qualified for the position of curator, but it is probable that there was too much work in the Natural History Museum for one man to do satisfactorily. Anyhow, the condition of the Museum and specimens was far from good towards the end of Captain Brown's time.

Captain Brown died on 8th October, 1862, and was succeeded by Thomas Alcock, M.D., who had been a member of the Council of the Natural History Society.

Dr. Alcock was an amateur rather than a professional curator. He had qualified as a surgeon in 1848, and in 1857 graduated M.D. at St. Andrews, but he was only in practice for a few years. Natural history was his hobby, and he had a fine private museum at Ashton-on-Mersey to which students were always welcomed. His work as curator of the Natural History Museum must have been hampered throughout by lack of funds, for the Society was anything but prosperous in his time, but such work as involved more labour for himself than cost to the Society he did, and did well. The Natural History Club, which consisted of enthusiastic amateur helpers of the Museum, owed its formation to Mr. R. D. Darbishire and Dr. Alcock. Dr. Alcock continued to be curator until the Museum's dissolution, and he died at Evesham, 14th July, 1891.

Dr. Boyd Dawkins, to whom, with Mr. Darbishire, the Manchester Museum owes so much of its excellence, was appointed curator in 1870.

Almost of equal importance with the curator was the

taxidermist, Timothy Harrop. He had been a weaver and was self-taught as a taxidermist. In office before the appointment of the first curator, Harrop seems to have been responsible for the manner in which the birds were displayed. The arrangement, which differed from that in every other museum of the time, and has not been followed by any other since, was a grouping of the specimens on artificial trees, each tree or separate branch being occupied by the species of one genus; each bird had a label, with its generic and specific name, and its English name, with the country which it inhabits. At the bottom of each tree or branch the generic name was attached, so that all birds of one genus could be traced. The birds could be displayed in more spirited attitudes than when placed on stands, and the branches had a picturesque effect. Other advantages of the method were the great economy of space, and the ease with which a specimen of a species hitherto unrepresented could be inserted in its proper place in the classification. The boughs were of wire, which could be attached to the stem wherever a new branch was required. Timothy Harrop was assisted and succeeded by his son, and between them they did all the taxidermy required by the Museum. Unfortunately their work was not proof against neglect, and little of it now remains. On one occasion the Council of the Museum had to object to Timothy Harrop's economical methods, for they found that he did not give his specimen two eyes if the bird was intended to have one eye to the wall.

The character of the Museum was largely influenced by the collections purchased in the early days before the cost of maintaining a museum prevented the purchase of specimens. Thus the Museum was always strong in its collection of birds, which in 1839 was considered to be little, if any, inferior to that in the British Museum.



John Leigh Philips's collection, with which the Museum started, contained many specimens, and one of the early purchases was a collection of birds belonging to Mr. Tomlinson, surgeon (1821). In 1822 Mr. Joseph Strutt, of Derby, sold his collection of minerals to the Society. In 1825 Robert and William Garnett presented the Egyptian mummy which for long was one of the most interesting features of the Museum, and Jesse Watts Russell presented a block of basalt from the Giant's Causeway. In the same year £650 was paid for Swainson's collection of shells and the cabinets containing it.

In 1826 the Rev. W. Roby presented various specimens, and in 1827 Robert Moffat and other missionaries made gifts.

In 1826 Lewin and Agnew's shells were purchased and Mr. Lingard presented fossils and minerals.

In 1828 a set of Bowland fossils was purchased. Dr. Henry presented organic remains and bones from Kirkdale Cave in Yorkshire, and Mr. Hardman presented a piece of Pompey's Pillar.

In 1829 a Burmese deity from Rangoon, a series of fossils from the Dudley limestone, and 31 Brazilian birds were presented.

In 1830 a model of a Buddhist temple from Ceylon was presented.

In 1831 Thomas Newton's collection of British birds was presented by his brother. Edmund Howarth presented birds from India. Two hundred specimens of volcanic productions from Mount Vesuvius, a large collection of foreign coleoptera, and some Furness minerals were also presented.

In 1832 the collection of shells was further improved by a purchase from Mr. Cumming. In 1833 Mr. Gilden's

collection of crustacea was purchased, and in 1835 Lady Parry presented a collection of sponges.

In 1835 the new Museum was opened, and a paid curator was appointed, and henceforward few additions of importance were purchased for the collection, the income being absorbed by current expenses and the preparation for display of the large collections already acquired.

In 1837 Richard Cobden made a handsome present of birds. In 1842 a number of coins were presented, and a valuable donation of reptiles by Thomas Norris rendered that section "tolerably complete."

In 1847 some fossils from the Yorkshire shale were purchased from Mr. Gibson. In 1848 Thomas Bellot presented some Chinese coins. In the same year the Council of University College, London, presented a Runic cross which had been bequeathed to it by Dr. Holme, of Manchester, and Dr. Holme's executors presented a Roman altar. The Runic cross was part of one of the crosses belonging to Lancaster Parish Church, and an effort was made to complete it by begging the remaining fragments from the Vicar of Lancaster.

In 1851 began a distribution of duplicates. In that year the Trustees of the Owens College asked for the gift of one specimen of each genus in Natural History of which there were duplicates, to illustrate the lectures of the Professor of Natural History. The Council willingly complied with the request, and Captain Brown was directed to select from the duplicates such zoological specimens as were not required for the collection, and after reserving a single specimen in each genus for the use of the Professor of Natural History in the Owens College, to forward a single specimen of each species which remained for the use of the Salford Museum.

In 1851 the Museum was enriched by the removal to

it of the geological collection belonging to the Manchester Geological Society. The geological specimens previously in the Museum were amalgamated with the Geological Society's collection, and the section constituted the best geological museum in the provinces. There was from time to time much friction between the Natural History Society and the Geological Society as to the custody of, and responsibility for, the united collection, and at one meeting of the Council of the Natural History Society a resolution was passed asking the Geological Society to appoint another representative on the Joint Committee because of the conduct of their representative. This was E. W. Binney, F.R.S., who, at the time of his death, was President of the Literary and Philosophical Society. Binney was a distinguished man, and really had at heart the interests of the two societies, but an autocratic temper and a great want of tact made him for several years a storm centre in Manchester scientific circles.

In 1854 Mr. H. E. B. Frere, afterwards well known as Sir Bartle Frere, presented 98 birds from Scinde, and Sir Edward Belcher, the explorer, presented some birds collected in the Arctic regions. Important accessions either by donation or purchase were afterwards few, though each year the reports record some donations of single specimens and small collections.

When Dr. Alcock became curator popular lectures were instituted in connection with the Museum, and were illustrated with specimens from the Museum. About the same time the Council had a pious resolution to devote more attention to botany, a section which had hitherto been neglected, excepting for the work in this direction of Thomas Coward, one of the honorary curators. Nevertheless the botanical section was never good.

No complete catalogue of the Museum was ever issued,

and the manuscript lists were very brief, but Dr. Thomas Ashton prepared a useful popular guide entitled "Visits to the Museum of the Manchester Natural History Society," printed in 1856, and several times reissued.

In 1849 a valuation of the collection was made, and I possess a copy of it in Captain Brown's handwriting. The furniture and books were valued at £686 11s. 10d., the showcases at £1,670 4s. 0d., and the collection at £5,042 11s. 1d., the total value, excluding the building, being £7,399 6s. 11d. Another valuation was made in 1861, and the value of the collection had increased only by £1,228 13s. 10d., the Geological Society's collection being responsible for £600 of this increase.

On the 13th November, 1867, a special meeting of Governors agreed to the dissolution of the Society as from the date of the next annual meeting, 29th January, 1868, and on the 8th January Commissioners were appointed to wind up affairs and to transfer the property to the Owens College on the terms already mentioned.

The Museum was closed as a public institution in 1868, but the collections, or portions of them, were still available for the use of students from that date to 1890, when the present Museum was opened. Of the specimens some regarded as useless were sold by auction, a few were given to other museums, and the local antiquities were transferred to the British Museum. The neglect, due primarily to the impecuniosity of the Society in its later years, had resulted in many of the specimens of birds and mammals becoming moth-eaten and of insects becoming faded. A great number of the specimens had thus to be discarded. The rarer specimens were retained and by judicious treatment made suitable for exhibition, and are now in the Museum. But in one way and another the collection had become so reduced that the University

authorities had to make almost a fresh start in some sections.

It must be acknowledged that as trustees the University have more than carried out their trust. The work of the Natural History Society is being carried on much more efficiently than it was, and the necessary cost is much more than the Society could have afforded, even in its most prosperous days. The endowment fund provided for the sale of the Society's property has been augmented by the gift of £10,000 from the Whitworth Legatees, one of whom was Mr. R. D. Darbshire, for long an active member of the Natural History Society, and a grant of £400 made for several years by the Manchester Corporation has been increased to £800.

The Manchester Museum is one of the finest museums in the country, and it is the only really important museum in South-East Lancashire. It is absolutely public, in the sense that the public have daily and free access to it. Yet the public, as represented by the City Council, contribute towards its cost only £800 per year. Other great cities have built museums and maintain them out of the rates. Manchester alone has left the provision and maintenance of its Museum to a private society and a university. It is a cheap arrangement for the city, but scarcely fair either to the University or the Museum. Although it is only recently that the Corporation grant has been increased, it is not too soon to point out that the grant is still inadequate. It is unworthy of the Corporation to spend so little in maintaining one of the greatest educational forces in the city.

For a student the old Museum had its value, and I have spent many pleasant and profitable hours in it. The general public were, it may be confessed, more interested in a few curiosities which owed their presence in the

Museum to other circumstances than their value as specimens of Natural History.

One of the specimens which in a Natural History Museum would be classed with mammalia was the mummy of Miss Beswick. She was an 18th century lady with fear of being buried alive. With this fear in her mind she left, so it is said, her body and her money to her medical man, Mr. Charles White, with the condition that she was to kept above ground for a century. Mr. White mummified her, and eventually the mummy was placed in the Museum. If Miss Beswick had known that her corpse would be gazed at by Manchester crowds in a Natural History Museum she would, I fancy, have preferred the risk of being buried alive to the ungentle fate of being a specimen in a museum.

At the dissolution of the Museum it was decided that she should be buried, and as the authorities of the cemetery could not bury her without a certificate of her death, signed by a medical man, it was necessary to appeal to the Secretary of State for an order for her burial, which took place in the Harpurhey Cemetery on 22nd July, 1868.

Another mammal, Napoleon's Arab-charger, was appropriately presented to the French Emperor Napoleon III. This quaint relic of the First Empire was placed in a cellar at the Louvre and remained unpacked for 36 years! The authorities found it in 1904, and it is now in the Army Museum at the Invalides in Paris. There has been some doubt as to whether this horse was "Vizier" or "Marengo," both famous chargers of the great Emperor. When, in 1842, it was presented to the Museum it was described merely as "Napoleon Bonaparte's cream-coloured Arabian charger," but as in the 1849 valuation (when it was valued at £30) and in Dr. Ashton's "Visits to the Museum" it is called "Vizier," there can be no doubt as

to the name of the animal. Another popular curiosity in the Museum was the venerable head of "Old Billy," a horse belonging to the "Mersey and Irwell Navigation Company" which attained the age of 62 years.

The Natural History Society does not seem to have had any meetings except business meetings, and this probably suggested the formation of the Natural History Club. The preliminary meeting of the Club was held on 12th November, 1861, when Messrs. Darbishire, Watson, Sidebotham, Coward, Latham, Harrison, Brown and Kenderdine associated themselves as the Natural History Club for the pursuit and cultivation of natural history. They were all members of the Natural History Society, all members of which were eligible for election as members of the Club; and associates of the Club, not exceeding ten in number, might be elected from outside the Society. Mr. Darbishire was the President, Mr. Watson, Treasurer, and Dr. Alcock, Secretary, and all retained office throughout the existence of the Club. It was never a large Club, but all its members were keenly interested in natural history. By permission of the Society the Club undertook the curatorship of the British Room in the Museum, and the reports on the different sections show that the Club did a much-needed work in the Museum. On 12th May, 1862, Mr. Darbishire contributed a paper of suggestions in furtherance of the curatorship of the British Room. The objects of the suggestions were, the more effective display of the specimens already in the Museum and the most judicious increase of the collection. From Mr. Darbishire's suggestions it appears that the British Section of the Museum was "far from perfect and often out of order," and he proposed that each of the different departments should be under the superintendence of a member of the Club having special knowledge of that department. He

concluded his suggestions with an appeal to collectors to give of their best to the Museum, on the ground that unique specimens belong of right to the public. The Club accepted Mr. Darbishire's suggestions as the basis of its work. The Society granted £10 to the Club for expenses in the arrangement of the British Room. The various superintendents reported on the collection in 1862. In crustacea Dr. Alcock found that "in their present state, they cannot be called a collection. Many of the specimens are imperfect, some are unnamed, and no kind of arrangement of them has been adopted," and in mammalia Mr. Darbishire noticed "the singular absence of excellence throughout. The specimens, with very few exceptions, are old and very dirty, some are atrociously stuffed," and he recommended the removal or destruction of many of the specimens. Dr. Alcock reported that the collection of British echinodermata was very good, though not complete. Mr. Sidebotham reported on the lepidoptera, that the specimens in the showcases were bleached and required renewal, while those in the cabinets were in fair condition and of considerable value.

I should like to mention here that on June 1st, 1863, I was proposed for membership of the Club, being already a member of the Society, by Mr. George E. Hunt and Mr. Thomas Coward, and was elected on June 30th, 1863.

In 1864 Dr. Alcock reported on the British mammalia, and showed that in the two years that had elapsed since Mr. Darbishire's report on the same class some improvements had been made, but that the collection still contained some poor specimens, though many of the old specimens had been discarded. It is obvious, however, that the Club had taken on more work in the Museum than it could manage, and its meetings were not well



attended. In August, 1864, proposals were made for converting the Club into a section of this Society, and eventually it joined the Microscopical Section (formed in 1858), which became the Microscopical and Natural History Section. The Natural History Club held its last meeting on October 31st, 1864, and on November 21st, 1864, eight of the Club, Messrs. Hugh Harrison, G. E. Hunt, Frederick Kenderdine, B. B. Labrey, J. Linton, John Hunt, Francis Nicholson, and J. E. Whalley, were elected associates of the Microscopical Section of the Literary and Philosophical Society. It was for the continuance of the work of this Club that the sum of £1,500 was allotted to the Literary and Philosophical Society when the Natural History Society was dissolved.



**I. Changes in the branchial lamellae of *Ligia oceanica*,  
after prolonged immersion in fresh and salt water.**

By Miss DOROTHY A. STEWART, B.Sc.

(Communicated by Professor Sydney J. Hickson, D.Sc., F.R.S.)

(Received and read October 21st, 1913.)

The series of experiments described below were carried out during the course of last winter in the Zoological Laboratories of Manchester University, the material used being numerous specimens of *Ligia oceanica* which I was enabled to obtain from Swanage through the kindness of Professor S. J. Hickson, F.R.S.

The group Isopoda, of the Crustacea, can be roughly divided into species which are (1) exclusively terrestrial, such as the woodlice, (2) those which are exclusively fresh-water, such as the *Asellidae*, and (3) those which are exclusively marine, such as the *Idoteidae*, etc. Among these forms *Ligia* occupies a somewhat interesting position, for although it is invariably found in the neighbourhood of the sea-shore, it is of amphibious habits, and there is a strong probability that it might, in course of time, if external conditions were altered, become adapted to fresh water or a purely terrestrial life.

*Ligia* is commonly found around the sea-coast, frequenting rock-pools, or, more usually, crawling over the stones some distance above high-water mark.

It appears to prefer a terrestrial rather than an aquatic habitat, but some difference of opinion seems to exist as to the exact position of its natural surroundings.

December 31st, 1913.

Bate and Westwood (1) quote it as occurring in the crevices of rocks, just above high-water mark, and observe that "it is seldom found under water."

Délage (2) is of the opinion that "although they live an exclusively terrestrial life, and cannot stay long in water without being asphyxiated, *Ligias* are marine animals, in the sense that the immediate neighbourhood of sea-water is as indispensable to them as the direct contact of it is harmful."

Webb and Sillum (5) remark that *Ligia* occurs on the sea-coast "at low tide, beneath stones." It would appear from this that the usual habitat of *Ligia* is the littoral zone of the shore, somewhere in the region of high-water mark, but it is worthy of note that the Isopod is occasionally found at a considerable distance from the sea-shore. (Hewitt (3) in St. Kilda found a number of specimens at a considerable height above the sea-level and quite out of reach of the spray.)

The fact that one often finds *Ligia* in the rock-pools, or crawling amongst the *Fucus* which covers the shore between tide-marks, leads one to speculate whether, if overtaken by the tide, the sea-louse could withstand several hours of total immersion in water.

The gills of all Isopods have approximately the same structure; it follows, therefore, that adaptation to a different habit is essentially an adaptation of the gills to different osmotic pressures, and it was with a view to investigating the effects of altered surroundings upon the gill structure that the following experiments were undertaken.

It may be remarked here that the results obtained are inadequate as yet to form a basis for any definite statement; numerous points remain to be cleared up, and a further study of the structure of the gills in relation

to the blood-system would be indispensable before any conclusions can be arrived at.

*The Immersion of Ligia in Fresh and Salt Water.*

The first experiments were carried out upon a number of specimens which were obtained from Swanage early in November ; these were large forms, and in a very healthy condition. Of these, three were taken and placed in a vessel containing fresh pond-water, in such a way that they were continually immersed, and were closely observed for a time ; simultaneously, a second batch was placed in a vessel of sea-water.

The specimens in fresh water swam about rapidly at first, and exhibited signs of considerable activity ; later, they settled down and moved about on the bottom of the vessel with their usual characteristic motion, but otherwise did not seem to be in any way affected by their changed surroundings.

The following morning, after immersion for 24 hours, one was dead, but the other two still survived and were apparently quite normal ; on the next day, however, they became very sluggish, sank into a dormant condition and eventually died.

On examination of the gills it was found that in all three cases the endopodites, or inner lamellae of all but the first pair, were considerably swollen and distorted. The expodites, however, were unaffected.

Of the three specimens in sea-water, all appeared normal and unaffected by the change during the first day, but at ten o'clock the next morning they were found to be dead.

A second batch, from the same collection, was again placed in sea-water, but these also succumbed after an immersion of eight hours. This would seem to indicate

that the effect of sea-water is more harmful than that of fresh, but as the quality of sea-water used in this experiment was very unsatisfactory, the contradictory result in this case may, I think, be fairly disregarded.

On examination of the gills of the latter specimens, they exhibited no such radical change as in the experiment with fresh water—death in the second case being probably due to the unhealthy composition of the water, rather than to asphyxiation from prolonged immersion.

The remainder of the *Ligias*, which were kept among a quantity of moist *Fucus*, in a tin receptacle, lived quite healthily for ten days.

The second collection of specimens was received from Swanage on Saturday, December 7th, and these again were large forms, in excellent condition, many being egg-bearing females; of these, four were taken and placed in fresh water, and four more were placed in a vessel of clean, fresh sea water.

On the following Monday, of the forms in fresh water, two were found to be already dead, and the other two were in a dying condition; in every case the gill lamellae were considerably distorted and swollen.

The *Ligias* in sea water, when observed after 24 hours' immersion, were all quite healthy, and displayed considerable activity; they were kept in the same vessel and lived for nine days, the water being kept continually changed, and death eventually seemed due to insufficient food rather than to the external conditions.

On a superficial examination the gills did not exhibit any abnormal features.

Several more *Ligias* from the same batch were also placed in a second vessel of sea-water, and lived for six days, without appearing to be in any way affected by the immersion.

In every case the gills were removed immediately after death and placed in a fixing solution of the following composition :—

|    |          |     |                      |
|----|----------|-----|----------------------|
| 90 | parts of | 70% | alcohol.             |
| 7  | „        | 5%  | formalin.            |
| 3  | „        |     | glacial acetic acid. |

They were left to harden for two or three days and then embedded, and cut into sections, which were ultimately stained with haematoxylin or brazilin.

#### *Microscopical examination of the Gills.*

The gills of *Ligia*, as in all Isopoda, are formed by the modification of the abdominal appendages, and appear as five pairs of white leaf-like structures upon the ventral surface of the body.

Each gill consists of a stout stalk, or peduncle, which bears two broad, leaf-like lamellæ, the endopodite and exopodite. (*Pl. I., Fig. 1.*)

They are very similar in external appearance, although the exopodite is slightly stouter and more opaque than the endopodite; in a transverse section, however, we see that there is a considerable structural difference.

The outer lamella (*Pl. I., Fig. 3.*), which is slightly larger than the inner, consists of loose cellular tissue, with numerous small nuclei, which stain deeply; through this tissue runs a well-defined and elaborate system of blood vessels, and the whole structure is surrounded by a wide hypodermal layer, and bounded by a thin cuticle.

The inner lamella (*Pl. I., Fig. 2.*), on the contrary, contains no such definite system of blood vessels, but consists chiefly of a broad, cytoplasmic layer of tissue, containing numerous large nuclei, and seeming to be of a

plasmodial nature, as no definite cell-structure could be made out in any of the sections.

This tissue surrounds a central lumen, which appears filled with very loose, colourless, and faintly defined cellular tissue; the whole structure, as in the exopodite, is bounded by a definite cuticle.

In every case the outer lamella extends considerably below the inner one.

The effect of the changed environment produces very diverse effects upon the gill structure.

Upon examination of a transverse section of the gills of specimens from the first collection, which had been immersed in sea-water, no definite change was observed, but in the case of *Ligias* from the second collection a gradual change was seen to have taken place, the endopodite being distinctly affected, while the exopodite remained more or less unaltered.

In a transverse section of the gill of a specimen kept for four days in sea-water, it was seen that the soft spongy tissue of the endopodite had become stringy or striated, and numerous fine strands or threads of protoplasm were stretched across the lumen of the lamella. (*Pl. I., Fig. 4.*)

In the case of a specimen which had survived for a week in sea-water, it was seen that the protoplasm of the endopodite had become somewhat swollen and diffuse; the obliteration of the lumen had been carried further by the spreading out of fine protoplasmic strands.

In another section of the gill of the same specimen (*Pl. II., Figs. 1. and 2.*), the cytoplasm was seen to be very diffuse and swollen, only retaining its original form around the scattered nuclei; the lumen had completely disappeared in places, and was only represented by one or two disconnected spaces, crossed by the thread-like fibres.



In this latter section, the exopodite also seemed to have lost some of its original shape, and was very compressed and much thinner, but more compact; no other change in the internal structure could be made out, and it is possible that the attenuated appearance may be due to the partial collapse or shrinkage of some of the larger blood-vessels.

It will thus be seen that the effect of sea-water on the gills is a very gradual one and does not lead to any sudden change of shape.

In the case of the *Ligias* which were immersed in fresh water, the distortion of the gill took place with considerable rapidity, being noticeable in every case after the animal had been submerged for about eight hours.

On examination of a T.S. of these gills (*Pl. II., Figs. 3. and 4.*), it was observed that whilst the exopodite remained unchanged, the endopodite had become very swollen—the lumen had practically disappeared, whilst the cytoplasm appeared very diffuse.

It is curious, however, that in this case the distortion of the gill lamella was confined only to one side; owing to this, the lumen appeared squeezed over to a lateral position, and thus was almost obliterated.

The general effect would seem to be somewhat similar to what was noticed in the forms submitted to the action of sea-water, but in the latter case the result was obtained in a much shorter time, the effect appeared to be greater, and the distortion was always confined to the inner border of the lamella. There was no evidence of any nuclear change in any gill which was examined; the altered form would seem to be due solely to the effects of the changed pressure acting upon the gill-surface, and causing more or less of a mechanical disturbance in the cytoplasmic portion of the gill tissue.

It is interesting to notice that Délage (2) in his description of the circulation of the blood of *Ligia*, states that the blood arrives from the venous cavities of the body into the *internal border* of the gill and returns round the *external border* to the pericardium, after traversing a system of lacunae.

It follows therefore that the external pressure on the gill surface would be greatest at the point where oxygen is being drawn into the impure blood: the fact that distortion of the gill lamella, after immersion in fresh water, invariably takes place on the internal border would seem to lend support to this view.

In the case of forms exposed to sea-water, there is no such sudden change of osmotic pressure acting on the most active point of the gill-surface, because the moisture already contained in the gill-cavities is probably of a saline composition; the gradual change of shape, therefore, which occurs at every point on the outer surface, is due more to the long-continued effect of the altered pressure acting evenly on the gill-surface.

These observations seem to point to the following conclusions:—

- I. The *internal lamella* of the gill is more directly concerned with respiratory functions than the *external lamella*, because it is at once affected by any changes in external conditions; the fact that the exopodite is not altered, even by a sudden change, would appear to indicate that its respiratory functions, if they exist, are very slight.
- II. Continuous contact with water for any period of time causes a corresponding change in the mode of breathing, and hence in the gill structure, which ultimately leads to death.

III. Fresh water acts far more rapidly than sea-water, and this would seem to indicate that *Ligia*, although it spends most time in terrestrial surroundings, possesses a considerable adaptability in regard to immersion in sea-water, which is probably indispensable in an animal whose habitat so closely adjoins the sea.

---

LIST OF AUTHORITIES QUOTED.

- (1) BATE & WESTWOOD (1863-68). "A History of the British Sessile-Eyed Custacea."
- (2) DÉLAGE (1881). "Contribution à l'étude de l'appareil circulation des Crustacés Edriopthalmes marins." (*Arch. Zool. expér.*, T. IX., 1881.)
- (3) HEWITT, C. G. (1907). "*Ligia*." *L. M. B. C. Memoir*.
- (4) UNWIN, E. E. (1909). "Respiration of Land Isopods." (*London Rep. of the Brit. Ass.*)
- (5) WEBB & SILLUM (1906). "British Woodlice."

EXPLANATION OF PLATES.

PLATE I.

*Fig. 1.*—Transverse section of the third gill of *Ligia oceanica* in the normal condition.

$a$  = endopodite,  $b$  = exopodite,  $c$  = peduncle.

*Fig. 2.*—Enlarged portion of a T.S. endopodite.

$a$  = cuticle,  $b$  = nucleated hypodermal layer,  $c$  = lumen.

*Fig. 3.*—Enlarged portion of a T.S. exopodite.

$a$  = cuticle,  $b$  = cellular tissue of the lamella,  $c$  = blood-vessel.

*Fig. 4.*—T.S. endopodite of the gill of a specimen kept for four days in sea-water.

The soft tissue has become stringy, and numerous strands of cytoplasm extend across the lumen.

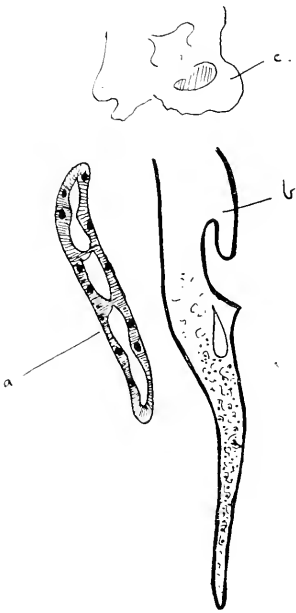

Fig. 1.

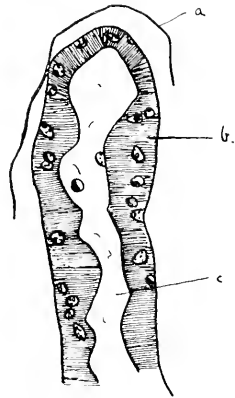

Fig. 2.

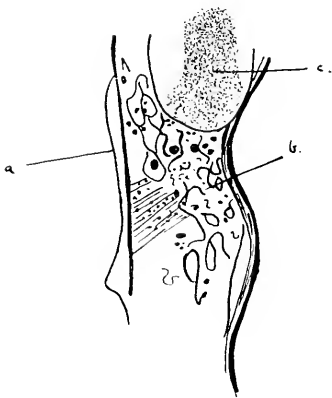

Fig. 3.



Fig. 4.





PLATE II.

*Fig. 1.*—T.S. of the gill of a specimen kept for one week in sea-water.

$a$  = endopodite,  $b$  = exopodite.

*Fig. 2.*—T.S. endopodite of the same gill, magnified by Zeiss objective  $\frac{1}{6}$ .

*Fig. 3.*—T.S. of the gill of a specimen kept for eight hours in fresh water.

$a$  = endopodite,  $b$  = exopodite,  $c$  = peduncle,  $x$  = point at which the gill is first affected.

*Fig. 4.*—T.S. endopodite of same gill, magnified by Zeiss objective  $\frac{1}{6}$ .



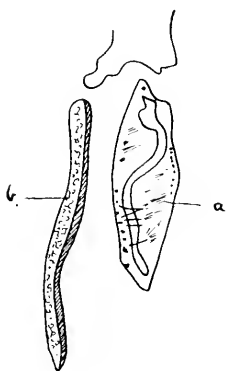

Fig. 1.

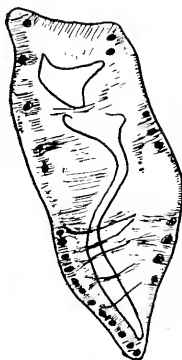

Fig. 2.

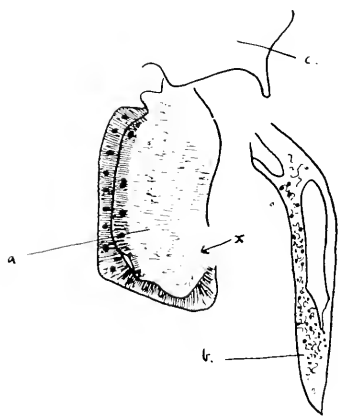

Fig. 3.

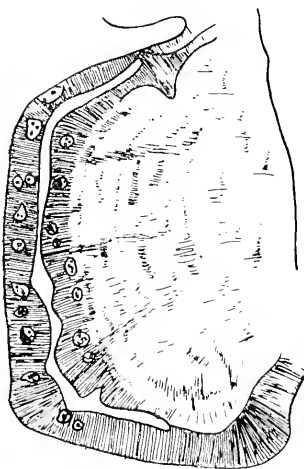

Fig. 4.



## II. Note on some products isolated from Soot.

By Professor EDMUND KNECHT, Ph.D.,

AND

Miss EVA HIBBERT.

*(Received and read November 4th, 1913.)*

In a paper on some constituents of "Manchester Soot" read before this Society in 1905 by one of us, soot which had been collected from ordinary household chimneys was extracted successively with water, dilute sulphuric acid, caustic soda and benzene, and the extracts were examined as far as circumstances would permit. The sample under examination was shown to have the following composition:—

|                                |        |         |
|--------------------------------|--------|---------|
| Ammonia (as ammonium sulphate) | ...    | 10.7 %  |
| Mineral matter (ash)           | ... .. | 19.6 %  |
| Acid and phenolic constituents | ... .. | 10.9 %  |
| Benzene extract (hydrocarbons) | ... .. | 13.0 %  |
| Difference (carbon ?)          | ... .. | 45.8 %  |
|                                |        | <hr/>   |
|                                |        | 100.0 % |

Soot collected in London and in Prague was found to contain much less extractive matter than soot collected in Manchester.

The benzene extract was subjected to distillation with a view to ascertain whether any definite organic compounds could be isolated by this means, and it was possible to show the presence, in the distillation products, of a beautifully crystallised white hydrocarbon, which

was identified as the heptacosane  $C_{27}H_{56}$  of Schwalb. Although the distillation was done rapidly, some doubt existed as to whether some of the products might have been formed by pyrogenic action (technically known as "cracking"), and for this reason we have now endeavoured to isolate individual products without having recourse to distillation at all, or at least only in one case, where it did not seem likely to exert a cracking effect. The work proved to be very slow and difficult, and as we do not consider the value of the results attainable to be commensurate either from a theoretical or a technical point of view with the time and material which it would be necessary to employ for a more complete research, we have decided to discontinue our work in this direction. We shall content ourselves, therefore, with recording here the somewhat meagre results which we have obtained.

The soot employed in the new experiments was household soot from the Warrington district. Mr. John Allan, chemist to Messrs. J. Crosfield & Sons, kindly undertook to extract 10 lbs. of this (very bulky) substance in a small extractor in their technical laboratory. The solvent employed in this very slow process was benzene, which was specially rectified for the purpose. The extract, after being freed from the solvent, amounted to about 2 lbs., and represented a semi-solid, pitchy mass, which softened on being heated, evolving a strong smell of soot. This raw material is referred to below simply as soot tar.

After having experimented on this soot tar with a great variety of solvents, we were ultimately successful in isolating a definite product from it by adopting the following procedure:—

The substance was extracted with petroleum ether, and after distilling off the solvent, the resulting yellow

oily liquid was treated with a large volume of hot alcohol. On cooling the solution thus obtained, a crystalline substance separated out, which on recrystallisation from alcohol, or better still from methyl acetate, yielded white crystals showing a constant melting point of 65°C. Ultimate analyses gave the following results:—

|   | I.  |     | II.                                       |     | Calc. for C <sub>27</sub> H <sub>54</sub> . |
|---|---|-----|---|-----|---|
| C | 85·52                                     | ... | 85·47                                     | ... | 85·71                                       |
| H | 14·37                                     | ... | 14·41                                     | ... | 14·29                                       |
|   | <hr style="width: 50%; margin: 0 auto;"/> |     | <hr style="width: 50%; margin: 0 auto;"/> |     | <hr style="width: 50%; margin: 0 auto;"/>   |
|   | 99·89                                     |     | 99·88                                     |     | 100·00                                      |

The compound absorbs bromine.

From the composition, melting point and bromine absorption, it is probable that this hydrocarbon is identical with the cerotene isolated by König and Kiesow from hay in 1873 (*Ber.* 6, p. 500). In order to satisfy ourselves that this occurrence was not an isolated case, a sample of soot from a different source was extracted directly with petroleum ether, and the residue, after distilling off the solvent, crystallised from alcohol as described. The same compound was thus obtained.

Later, we found that the hydrocarbon can also be obtained by extracting the soot tar with glacial acetic acid, when about 90% of the latter goes into solution. The insoluble residue is dissolved in hot alcohol, and the product which separates out on cooling is recrystallised several times from ethyl acetate.

The solution of the soot tar in glacial acetic acid (referred to above) was diluted with water, when an oily substance separated out, and this was taken up in ether. The ethereal solution was first extracted with a 5% solution of caustic soda, and when thus freed from acid and phenolic constituents it left on evaporation a dark coloured semi-solid tar, which was distilled in vacuo.

The greater portion of the distillate came over at a constant temperature of  $300^{\circ}\text{C}$ ., and formed a yellow oil which was further purified by redistillation. The ultimate analyses yielded the following figures :—

|   | I.        | II.       | Calc. for $\text{C}_{15}\text{H}_{16}\text{O}$ . |
|---|-----------|-----------|--|
| C | 84.79 ... | 84.70 ... | 84.90  |
| H | 7.70 ...  | 7.64 ...  | 7.55   |

The substance had a slight but pleasant odour and was sparingly soluble in benzene and in alcohol, but more soluble in ether and in chloroform. Its solution in chloroform is dextrorotatory ( $\alpha_{\text{D}} = 8^{\circ}$ ). The fact that it must contain oxygen and at the same time cannot be a phenol or an acid (as it is not taken up by caustic soda) would suggest that it is either an alcohol or some other carbon compound containing oxygen. In 1890 Freund and Remse described an alcohol (*Ber.* 1890, p. 2863), which they had obtained synthetically and to which they ascribed the formula of a diphenyl isopropyl alcohol. It was obtained as a liquid which boiled under reduced pressure at  $300\text{--}302^{\circ}$ , and as is shown by their formula contains an asymmetric carbon atom.

The portion of the soot tar which dissolved in caustic soda was precipitated by sulphuric acid, filtered off, re-dissolved in sodium carbonate, and again precipitated by acid, and thus yielded a yellowish brown substance which dissolved in alcohol and crystallised out on cooling. Several recrystallisations from this solvent resulted in a substance having a light yellowish brown colour, and showing a constant melting point of  $135^{\circ}\text{C}$ . Ultimate analysis gave the following figures :—

|   | Calc. for $\text{C}_6\text{H}_6\text{O}$ . |
|---|--|
| C | 73.82 ... 74.07                            |
| H | 6.19 ... 6.17                              |

The compound seems to be an organic acid having the composition  $C_{10}H_{10}O_2$ . It forms a lead salt which is decomposed by dilute nitric acid, yielding the free acid with its original m.p. Methyl atropic acid described by Oglialoro (*Gazz. chim. Ital.* 15, 514) has the same empirical formula and the same m.p. This acid, like ours, is sparingly soluble in cold water.

By extracting the soot tar with water, a solution was obtained which gave the reactions for guajacol. This may not have emanated from the coal but from the wood used in lighting the fires.





### III. The Willow Titmouse in Lancashire and Cheshire.

By T. A. COWARD, F.Z.S., F.E.S.

*(Received and read January 27th, 1914.)*

It is nearly sixteen years since it was first pointed out that the Willow Tit was distinct from the Marsh Tit, that in fact all previous British ornithologists had shut their eyes to the possibility of specific variation amongst the black-headed titmice which occur in Britain, although many of them were well acquainted with the races and subspecies which were found on the Continent and in America. The announcement was sufficiently startling to explain much of the incredulity of the older school of ornithologists; it is, however, surprising that there are still many who are interested in birds who are ignorant of the facts. Not only are the characters of the two species evident to those who will take the trouble to examine specimens, but the birds may be recognised in the field, which is more than can be said of the geographical races or subspecies of certain birds, where the differences can only be seen when large numbers of specimens are examined and compared.

The black-capped titmice of the genus *Parus*, considered as one Holarctic group, show marked variation in different parts of the range. The extremes have been given specific rank, and now the more minute workers are drawing the bonds of relationship closer although increasing the number of subspecies. The forms fall readily into two main groups, the one having as its type *Parus palustris* of Linnæus, which we may call the Marsh Tit

*March 27th, 1914.*

group, and the other *Parus atricapillus*, named by Linnæus from a Canadian bird. This we now take as the representative of the Willow Tit group.

Perhaps the most noticeable difference between the two groups is in the colour of the cap; in the Marsh Tits it is blue-black and more or less glossed; in the Willow Tits it is sooty or brown-black, and without gloss. In addition, the feathers which are thus coloured are longer and more loosely arranged in the Willow than in the Marsh Tits, and in the majority of the races are continued further along the neck.

In the next point of difference, the colour of the edges of the secondaries, there is great variation, not individual nor local but racial. In the extreme, the typical *palustris*, represented in our islands by the subspecific form, *Parus palustris dresseri* Stejneger, the pale edgings are scarcely noticeable, but in the Norwegian bird of the *atricapillus* group, *Parus atricapillus borealis* Selys-Longchamps, these edgings are so nearly white that they give the impression of a white patch on the closed wing of the bird.

A slight structural difference is not so marked in our subspecies as it is in some of the other forms. The two outer tail-feathers are longer in the Marsh Tits than in the Willow Tits, and the effect is to give a squarer appearance to the spread tails of the Marsh group, or a rounder, more graduated one to those of the Willow group. Other differences, such as the amount of buff on the flanks, are noticeable in certain subspecies, but are not equally well marked in others.

In 1897 Pastor Kleinschmidt and Dr. Hartert were examining skins of the group in the British Museum collection when they noticed two birds, obtained at Hampstead, which approached the brown-headed rather

than the blue-black headed type. In the same year the Tring Museum received two of the same form which had been taken at Finchley. Kleinschmidt announced the new British subspecies of the Alpine *Parus montanus* in a little-known German work,<sup>1</sup> but he gave the bird no special name. Two years later Hellmayr named it *Parus montanus kleinschmidti* after its discoverer.<sup>2</sup> Hartert, however, considering that the distinction between the Willow Tits of the Old and New World is not of specific value, gives the bird the earlier name, and calls it *Parus atricapillus kleinschmidti* Hellmayr.<sup>3</sup>

It was not until the year 1907 that the "new" species came prominently before the notice of many British ornithologists, some of whom were well acquainted with and admitted the specific value of the birds of this group which occur on the Continent. In that year P. L. Selater asked for further details about this "supposed new British Tit,"<sup>4</sup> and the Hon. Walter Rothschild promptly replied,<sup>5</sup> supplying full particulars of the knowledge of the British Willow Tit up to date. This roused many observers to critically examine all the Marsh Tits which they saw or which were in collections, with the result that in a few years it was found that the Willow Tit occurred in practically all parts of England and Wales, though mostly in smaller numbers than the Marsh Tit, and that it was a resident, breeding in many places. A still more surprising result was the discovery that nearly all, if not all, of the so-called Marsh Tits in Scotland were really Willow Tits.<sup>6</sup>

The fact that Mr. C. Oldham and I had recently

<sup>1</sup> *Orn. Monatsber.*, vi., 34.

<sup>2</sup> *Ornithologische Jahrbuch*, xi., 212.

<sup>3</sup> "Die Vögel der paläarktischen Fauna," 378.

<sup>4</sup> "British Birds," i., 23. <sup>5</sup> *Ibid.* i. 44.

<sup>6</sup> Hartert, etc., "A Hand-list of British Birds," 1912, 46.

published a list of the birds occurring in Cheshire,<sup>7</sup> and had made no mention of the Willow Tit, although we had, of course, included the Marsh Tit, made me anxious to discover the status of each species in the country. I examined every Marsh Tit I saw as carefully as possible, and also looked at the few specimens in museums and local collections. The result of my investigations is that the Willow Tit does occur in Cheshire and South Lancashire, but that if compared with the Marsh Tit it is decidedly rare. We were, in a measure, more fortunate than Mr. Hugh S. Gladstone, who published his "Birds of Dumfriesshire" in the same year, and who described the British Marsh Tit as "A very scarce and very local resident,"<sup>8</sup> and added that the British Willow Tit had not been detected in the county. In 1912 he modified this by saying that "Previous local records of the British Marsh Titmouse, *Parus palustris dresseri*, should presumably be applied to this species."—*P.a. kleinschmidti*."

I found that there were two Willow Tits in the Warrington Museum, and submitted them to Mr. Witherby for confirmation. One of these birds was obtained at Padgate, near Warrington, in 1890, but the locality and date of the other has been lost, although Mr. Madeley feels sure that it is a local specimen and probably from Lancashire.<sup>10</sup> Birds in the Grosvenor Museum, Chester, and in other collections were Marsh Tits, but in order to support my opinion I forwarded a couple for confirmation to Mr. Witherby.

In December, 1911, I looked through the British-taken black-capped Tits in the Dresser collection, but found only one which I thought was incorrectly labelled.

<sup>7</sup> "The Vertebrate Fauna of Cheshire," 1910, 1.

<sup>8</sup> "Birds of Dumfriesshire," 1910, 40, 41.

<sup>9</sup> "A Catalogue of the Vertebrate Fauna of Dumfriesshire," 1912, 16.

<sup>10</sup> "British Birds," iv, 1910-1911, 337.

It was a bird which had been killed in Hampstead, and was marked on the label "Type of Birds of Europe." Dr. Tattersall submitted it, together with one which we were agreed was a Marsh Tit, to Dr. Hartert. He replied confirming our identification.

"Undoubtedly a Willow Tit; it is, however, not an adult, but a bird of the year. It is doubtless the specimen from which *Fig. 2* (*Plate 109* of Dresser's "Birds") has been taken, though Mr. Dresser at the time does not seem to have noticed that it is a young bird. The other specimen is, of course, a Marsh Tit and not a Willow Tit."

Unfortunately, the artist also seems to have ignored the brown-black of the head, for the specimen figured is painted with a glossy head like the others on the same plate.

On April 17th, 1912, my attention was arrested by the brown-black head of a Tit, one of a couple which I saw in a wood near Rostherne; I was satisfied that I had at last identified the bird in Cheshire. On the following day, by a curious coincidence, Mr. A. W. Boyd saw a pair of birds, which he was equally sure were Willow Tits, in Boggart-Hole Clough, Manchester. We recorded the birds in the same number of "British Birds."<sup>11</sup> Mr. Boyd mentions a fact, which has been noticed by others, and with which I heartily agree, that the Willow Tit looks "altogether duller" than the Marsh Tit. It is worth mentioning that a few days later I found a Marsh Tit nesting in an adjoining wood to the one in which I saw my birds.

Just a year later, on April 15th, 1913, I noticed that a pair of Willow Tits were engaged in excavating a nesting hole in an old white willow in a wood not far from Bowdon. Throughout the season I watched these

<sup>11</sup> "British Birds," v., 328, 329.

birds constantly, and was able to see them on many occasions at very close quarters. Messrs. A. W. Boyd, T. Hadfield, C. Oldham and Dr. Tattersall also saw the birds. For the first ten days the pair only occasionally visited the hole, but on the 25th they were working very hard; both birds excavated and carried away the chips of rotten wood. These chips were not dropped at the foot of the tree, but were carefully carried to a neighbouring tree and then allowed to fall. On or about May 2nd incubation began, but I could not tell what share, if any, the male bird took in this work. By the 16th of the month the young were evidently hatched, and both birds were occasionally absent from the tree, seeking food for the young, at the same time. On June 7th I found both of the old birds in the bushes at the foot of the nesting tree, and they paid no visits to the nest; I am unable to say if this brood was successfully brought off. On July 17th, however, I saw a pair of Willow Tits, accompanied by two or three, if not more, young birds, feeding in alders and reeds in another part of the wood.<sup>12</sup>

A glance at the remarks made by the better-known and more recent writers on birds reveals some interesting variation in the description of the head of the Marsh Tit. Taken in order of date, we find that Colonel Montagu, in 1802, says: "Crown of head black, but not glossy." Pennant merely quotes from Montagu.

William Macgillivray, in 1837, described the bird thus: "The head and throat brownish-black—the plumage is blended, very soft and tufty, the feathers much elongated on the hind part of the back.—The upper part of the head and the hind part of the neck are black, with a tinge of brown—the quills, their coverts, and the tail-feathers dark brownish-grey, margined with yellowish-grey, the

<sup>12</sup> "British Birds," vii., 110.

secondary quills with yellowish-brown." These points are valuable, as I shall show.

Mudie, in 1853, says: "The plumage is more downy and free from gloss than that of the former species (the Coal Tit); and the black on the head is not so deep, though from being entire and having no lustre, it shows better."

Newton, in "Yarrell," 4th edition, 1871-4, calls "the forehead, crown and nape black, slightly glossed with bluish-green."

Gould (1873) made an unfortunate error, for he depicted two undoubted Marsh Tits with glossy blue-black heads and quoted Macgillivray's description.

Seebohm (1883), after discussing *borealis* and other forms, says "the typical form of the Marsh Tit has the head, from the base of the bill to the nape, bluish black."

Sharpe (1896) describes the "crown of head glossy blue-black."

Saunders (1899) remarks: "upper part of head and nape glossy black."

Stonham (1906) says: "Forehead, crown and nape glossy black."

Kirkman and his helpers, in the recently completed "British Bird Book," figure and describe both species.

The natural conclusion from this list is that Newton, Seebohm, Sharpe and Saunders were all correctly describing *Parus palustris*, although all four refer to racial variation. Montagu, Macgillivray and Mudie took their descriptions from Willow Tits, and Macgillivray's is, perhaps, the most important, for he distinctly states that the birds he examined were obtained in Scotland. This, then, bears out the opinion that is now generally held that the Willow Tit, and not the Marsh Tit, is the black-headed titmouse north of the Border, or, at any rate, that

it is more frequent there than the latter species. Practically no study had been made of geographical variation in Macgillivray's days, so that we can hardly accuse him of having made an error. He was an original and careful worker, and he accurately described the birds which came into his hands. His description may thus be taken as the first really full account of the Willow Titmouse.

---



**IV. Observations on the Homopterous Insect *Phromnia*  
(*Flata*) *marginella* Oliv. in the Himalayas.**

By A. D. IMMS, M.A., D.Sc.,  
*Reader in Agricultural Entomology, University of Manchester.*

(Received and read, January 27th, 1914.)

Several instances have been brought to light of the Homopterous genus *Phromnia* (*Flata*) bearing a remarkable resemblance to certain flowers. The earliest with which I am acquainted is Prof. Gregory's<sup>1</sup> account, published in 1896. In the frontispiece to his book he figures a cluster of insects belonging to this genus, closely congregated on the upper part of a stem, and bearing a curious resemblance to a flowering spike. The species to which he refers exists in two forms, viz., a green and a reddish one. In the illustration, the insects are represented so grouped on the stem, that the green individuals occupy the upper portion, and the red individuals are situated just beneath them, on the lower portion. In this attitude they are curiously like a red-flowered spike with the green unopened buds above. In 1902 Hinde<sup>2</sup> published an article on this same subject. He remarks that he had many opportunities of seeing the insect and still oftener its larva in British East Africa, and his paper is accompanied by coloured drawings made in the field by his wife. He states that Prof. Gregory's plate was

<sup>1</sup> J. W. Gregory, "The Great Rift Valley," pp. 273-275.

<sup>2</sup> S. L. Hinde, "The Protective Resemblance to flowers borne by an African Homopterous Insect, *Flata migrocincta* (Walk), *Trans. Ent. Soc., Lond.*, 1902, pp. 695-700; pls. xxvi.-xxvii. Also "*Proceedings*," pp. xxvi. and xxvii.

*April 15th, 1914.*

apparently drawn from dried specimens in England, and that the green forms are not noticeably smaller than the red forms, in spite of their being represented so in Prof. Gregory's figures. He, furthermore, adds that he has never seen the insects grouped together according to their colours, but invariably mixed; and neither has he noted the larvæ and imagines on the same stem, nor even together on the same bush or tree. He also states that he has never seen the imagines on vertical stems, but always on those which are actually or approximately horizontal. It by no means follows that Prof. Gregory was mistaken in his impressions, but the curious condition which he describes appears to be far from common. Hinde's specimens have been compared with Gregory's by Prof. Poulton in the British Museum, who states that both the series belong to the same species, viz., a form slightly different to *Flata migrocincta* (Walk.), but evidently closely allied and perhaps specifically identical with it. Hinde remarks that both he and his wife recognised a strong superficial likeness between the mixed group of insects, and the flowers and buds of a leguminous plant with which they are perfectly familiar. He states they have mistaken the groups of insects for the flowers and *vice versa*. Prof. Gregory (p. 275) considers that the eggs of *Flata* are laid from below upwards, so that the insects towards the top of the stem would be the youngest and most immature. Prof. Poulton states that the difference in colour cannot be due to immaturity, as old worn examples of the green form are known to occur. The first specimens of a group to emerge may, however, be red, and those that issue later green; and Prof. Gregory may have come across undisturbed groups which, therefore, had the green specimens above and the red ones below. Hinde's observations may have been made upon

examples which had re-assembled, and thus lost the arrangement which it is possible they may have possessed on emergence from the pupa.

In 1912 Mr. Gahan<sup>3</sup> exhibited before the Entomological Society of London a small series of *Phromnia superba*, Melich., a "dimorphic" species of Homoptera taken by Dr. A. C. Parsons in Northern Nigeria. In a letter Dr. Parsons remarks that one day when he was in the jungle his attention was arrested by a dove-coloured "pea flower." On attempting to gather it the "blossoms" flew up in a cloud of fluff about his head, and then re-settled individually among the brushwood. He mentions that the folded wings are the exact shape of the keel of a pea-flower, and the insects were all arranged on the bare stem of a bush. Their heads were all pointing in the same direction, their colour graduating from green at the top of the twig to a deep dove-colour, that would indicate the lowest blossom below. Mr. Gahan remarked that Dr. Parson's observations were a strong confirmation of those of Prof. Gregory. At the same meeting of the Entomological Society W. A. Lamborn<sup>4</sup> exhibited a series of specimens of the genus *Flata*, all taken together from one plant about 70 miles E. of Lagos. He states that the insects were "dimorphic," pink and green forms being intermixed as they rested on the same plant. He had not noticed any definite arrangement according to colour as observed by Dr. Parsons although he was acquainted with the same species.

While touring in the Himalayan foot-hills of Kumaon in the Naini Tal district during June and July, 1909, I came across some examples of an Indian species of the genus, viz., *Phromnia magnella*, Oliv. They occurred in

<sup>3</sup> Vide *Proc. Entom. Soc. Lond.*, pp. lxxxviii.-xc.

<sup>4</sup> *Proc. Ent. Soc. London*, 1912. p. xc.

the jungle around the Sat Tal lakes at an elevation of about 3,500 feet.

The larvæ were found plentifully during the middle of June, clustered on the leaves and twigs of several species of small forest trees. They are covered posteriorly (*Pl. II., Fig. 3*) with long white waxy filaments, which render them very conspicuous even from a distance of 12 or 15 yards. The clusters of these larvae bear a resemblance to groups of small white blossoms. I may add that two friends who were with me at the time, and neither of them entomologists, quite believed them to be flowers until the insects dispersed by a series of leaps when disturbed. The white filaments of the larvae, when removed, stick tenaciously to any object brought in contact with them. For this reason I believe that, in all probability, they render the insects distasteful to birds. If a larva be seized by a bird, the filaments would cling to the outside of its beak, and would probably be removed only with difficulty, after causing the bird a good deal of discomfort. The larvae were found both on horizontal and vertical twigs, and also on the leaves, but exhibited no marked arrangement according to the age of the individuals forming any particular cluster. No examples of the perfect insect were then to be found. The larvae suck the juices of plants, and gradually increase in size after each moult until the arrival of the monsoon season, when the perfect insects commence to emerge. Some fourteen days later I revisited San Tal, and a few of the larvae were still noticeable, but the majority had reached the winged state. A number of the exuviae of the larvae attached to the trees were evident with their waxy filaments still intact and it needed close examination to distinguish them from living insects.

The mature insect exists in two forms, a pea-green

and a pinkish-buff, both having pearly white hind wings. It is nocturnal, so far as my observations go, and during the day is found resting in closely packed longitudinal groups on the twigs and branches of small forest trees; the heads of the insects all point in the same direction. The green form is considerably more abundant than the buff coloured one, and only on two occasions I noticed both forms on a branch together. In these two instances they were intermixed and exhibited no definite arrangement into the green forms above and the buff-coloured examples below. I am not, however, prepared to assert that this arrangement never occurs, and if Prof. Poulton's interpretation be correct, it must of necessity be rare to come across such an occasion. It is to be hoped that Indian entomologists will endeavour to clear up this interesting feature, and the early part of July should be the most likely time in the Himalayas to conduct observations. The insects bear a considerable resemblance to leaf or flower buds just about to open, and the buff-coloured examples appear very like unopened petals. Out of seven colonies which I came across, all were disposed along the middle or base of branches among the foliage, and not at the apices of the twigs (*Pl. I., Fig. 1*, and *Pl. II., Fig. 2*). This fact rather mitigates against the resemblance, though they closely harmonised with the surrounding foliage. Whether the resemblance is sufficient to deceive their enemies I am not in a position to say. In this connection, however, it is noteworthy that when individuals settled singly on leaves after being dispersed, they were certainly more conspicuous to human eyes than when grouped together on the twigs and branches. Kershaw<sup>5</sup> states that two species of the genera, *Salurnis* and *Geisha*, closely allied to *Phronnia* and found

<sup>5</sup> "Notes on *Flata*," *Journ. Bombay Nat. Hist. Soc.*, 1912, xxi., p. 609.

in S. China, are solitary as a rule, though several individuals may sometimes be found on the same bush. On the other hand, he remarks that an Australian species, *Neomelicharia furtiva*, is gregarious, having the same habit as *Phromnia* of many individuals resting closely together on the same twig or branch.

In addition to Sat Tal, I have found *Phromnia marginella* near Ganai in British Garhwal, and it is also known from the Central Provinces, Dehra Dun, Sikkim, the Naga Hills, Cachar, Mussoorie, Margherita (Assam), Tavoy, and Siam.<sup>6</sup> It also occurs plentifully in Ceylon, and Mr. E. E. Green informs me that both forms are met with in that island, but the green form predominates there. He states that he has never seen the two forms intermingled in one colony, though he would not be prepared to state that it never happens. On the few occasions that he has observed the buff form, the whole colony has been of that colour. *Phromnia marginella* has been confused in literature with the Indian wax insect *Ceroplastes ceriferus*, Sign. (Fam. Coccidae), which appears to be comparatively rare, and has never been commercially utilised, though it produces some amount of wax. It has also been confused with the Chinese white wax insect (*Ericerus pe-la*) by Staunton,<sup>7</sup> and in Westwood's edition of Donovan's "Insects of China." Although this error was pointed out by Hutton,<sup>8</sup> it has been repeated by later writers. It is further noteworthy that *Ericerus*, like *Ceroplastes*, belongs to the family of the Coccidae and not to the Fulgoridae.

Bugnion and Popoff<sup>9</sup> have investigated the wax

<sup>6</sup> E. C. Cotes, "White Insect Wax in India." *Ind. Mus. Notes*, vol. ii., p. 97.

<sup>7</sup> "Embassy to China." London 1797, vol. i., p. 353.

<sup>8</sup> *Journ. Asiatic Soc., Bengal*, 1848-55, vol. ii., p. 379.

<sup>9</sup> *Bull. Soc. Vaud. des Sci. Nat.*, 1907, vol. lxiii., pp. 549-63, pls. xl.-xlvii. and four text-figs.

glands of the larvæ of *Phromnia marginella*, obtaining specimens from Gimgatenagap in Ceylon at an altitude of 2,165 feet. They were found on January 26th on *Salacia reticulata*, a plant belonging to the Hippocrateaceæ. They state that the wax glands are situated beneath a chitinous disc, placed at the extremity of the abdomen, and divided into a series of twenty plates. These plates are arranged in four rows—two rows to the right and two to the left of the anal and genital apertures. Each plate is studded with small pores, which are the orifices of the wax glands

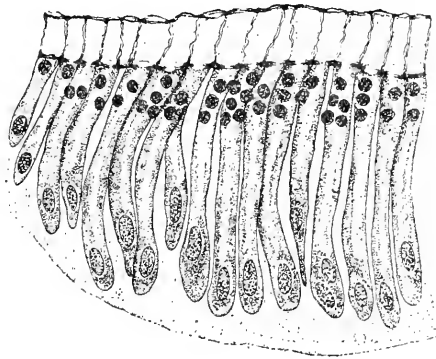

*Text-fig.*—Vertical section through a wax plate of a larva of *Phromnia marginella*, showing the pores in the cuticle and the elongate wax-secreting cells beneath. (After Bugnion and Popoff.)

secreting the long white filaments. In addition, there are also three small plates on either side of the sixth abdominal segment, two on either side of the fifth, and one or two on either side of the fourth. There are also scattered isolated pores on the dorsal side of the body, which is powdered with a small amount of wax. As shown in the accompanying *text-figure*, the cuticle covering the wax plates is very thick and traversed with vertical striae. Beneath the cuticle is the hypodermal layer, chiefly evident by its

small rounded nuclei. The wax-secreting cells are specialised cells derived from the hyperdermis and are greatly elongated with the nuclei at their inner ends. Each wax cell is traversed by an elongated cavity into which the wax secretion congregates, to be ultimately discharged through the corresponding pore to the exterior. With regard to the structure of the cuticle, Bugnion and Popoff remark: "L'emploi d'un grossissement plus fort a permis de constater que les stries verticales ne sont pas des canalicules, mais répondent au contraire aux lammelles chitineuses qui limitent les pores. Les pores sont les espaces clairs compris entre les stries. On voit de plus: (1) que chaque pore surmonte une cellule unique: (2) que le pore offre à sa base un collet rétréci, large de  $2\frac{1}{2} \mu$ , la chitine l'enserrant à ce niveau dans un épaississement en forme d'anneau. La partie profonde de la cuticle apparaît sur les coupes obliques comme une lame jaune percée de trous ronds à contours très accusés. Ces trous répondent aux collets des pores." There has been a good deal of difference of opinion as to the chemical nature of the waxy filaments of the larvae of the Flatid group of the Fulgoridae. Spinola<sup>10</sup> makes a general statement with regard to the wax secreted by the 'Fulgoresses.' He says that it dissolves entirely in alcohol and gives off a distinct odour of horn when burnt in a flame of a candle. Coates<sup>11</sup> states that Murchison examined the white filaments of a Fulgorid which was either *P. marginella*, or a species closely related to it, and remarked that they were composed of what he believed to be wax. An examination made by T. H. (now Sir Thomas) Holland on Coates' behalf of the filaments of larvæ of *P. marginella*, preserved in the collections of the

<sup>10</sup> "Essai sur les Fulgoresses." *An. Soc. Ent. Fr.*, T. viii., 1839, p. 197.

<sup>11</sup> *Loc. cit.*, p. 92.



Indian Museum, has not confirmed Murchison's statement. The white filaments attached to the specimens in the Indian Museum were found to consist of fibrous matter which not only refuses to melt but, on the contrary, decomposes when heated, does not dissolve in naphtha, and under the microscope appears to consist of minute particles of a filamentous nature. That observed by Murchison melted on heating into transparent colourless wax, which was readily soluble in naphtha, crystallised on cooling into acicular spicules, arranged in stellate masses, such as is readily observable in the wax secreted by *Ceroplastes ceriferus*. These observations seem to the present writer to show that Murchison probably was not dealing with *P. marginella*, but with an allied species. In selecting material for analysis it is desirable to use the distal two-thirds of the filaments as the basal portion when amputated frequently comes away with portions of the chitinous integument which is liable to give misleading results. Kershaw<sup>12</sup> states that the waxy filaments of the Australian *Salurnis marginellus*, Guer. dissolve instantly in spirit, and melt with heat, are of a waxy nature, but a large part consists of hollow filaments or hairs, much broken and interlaced, insoluble in either spirit or potash, apparently much resembling in chemical nature the hairs which project beyond the anal segment of certain leaf-hopper nymphs. I am indebted to the kindness of Professor A. Lapworth, F.R.S., for making an analysis of the white filaments of the larvæ of *P. marginella*, which he states are closely allied to Chinese white wax in chemical composition. He remarks that it is freely soluble for the most part in chloroform, but is sparingly soluble in alcohol even when heated, but dissolves after some hours boiling in methyl alcoholic potash. On pouring

<sup>12</sup> *Loc. cit.*, p. 608.

the product into water, acidifying, extracting the ether, drying and evaporating the latter, a semi-crystalline mass was left. This was neutralised with methyl alcoholic baryta, dried at 100°C. and extracted with acetone. The acetone dissolves a crystalline material, probably one of the higher fatty alcohols. Indications of cholesterol were absent ; the barium salts, remaining after extraction with acetone, were treated with warm hydrochloric acid, the liquid extracted with ether, then dried and evaporated, and a solid fatty acid was left. This had all the characters of a higher fatty acid. The substance is unaffected by five minutes' heating at a temperature of 100°C. with strong sulphuric acid, showing that it is not of a glucositic nature.

In addition to wax, the larvæ of *Phromnia marginella* excrete a liquid giving a sweet taste, which falls on the leaves where it hardens. According to Cotes,<sup>3</sup> in Garhwal it is recorded that the natives eat this excretion, and term the insects which produce it "Dhaberi," meaning sheep, in allusion to their habit of clustering together and jumping away when disturbed. Nothing appears to be known as to method of origin of this fluid, whether it is excreted through the anus or by means of special glands.

<sup>13</sup> *Loc. cit.* p. 97.



EXPLANATION OF THE PLATES.

PLATE I.

*Fig. 1.*—A photograph showing two groups (*a* and *b*) of *Phromnia marginella* congregated along branches in their characteristic resting attitude. (Sat Tal., July, 1909.)

PLATE II.

*Fig. 2.*—An enlarged photograph of the lower group of insects seen in the preceding plate.

*Fig. 3.*—A photograph of a group of larvae of *Phromnia marginella* on a leaf of a species of *Grewia*? (Sat Tal., July, 1909.)



Fig. 1.

A. D. Innes phot.





*Fig. 2.*

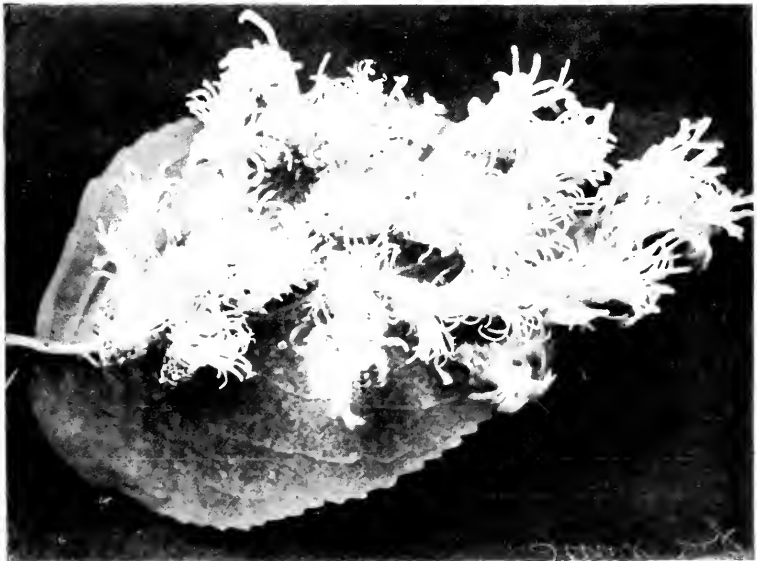

*Fig. 3.*





V. The Specification of the elements of Stress. Part  
III. The definition of the dynamical specification  
and a test of the elastic specification. A chapter  
in Elasticity.

By R. F. GWYHER, M.A.

*(Read and received February 10th, 1914.)*

INTRODUCTION.

(i.) In this paper I make use of the phrase "dynamical specification" of stress in an elastic substance, and I contrast or compare it with the "elastic specification" of the stress in the substance, and I must explain at the outset the conceptions from which the idea and the employment of the unusual term has originated.

The general idea of an elastic body, whether isotropic or crystalline, need not be restated, and it is not proposed to alter in any way the "elastic specification" of stress as derived in the modern method from Green's restatement of the relations between stress and strain. It is, however, convenient to refer to the whole set of relations as "Hooke's Law," although it is not now in the form as stated by Hooke.

In order to state the point of view taken in this paper in as simple a form as possible, I shall suppose that we are dealing with a homogeneous isotropic elastic solid, and, at a point in this solid statically strained, I shall imagine a strain quadric and an elastic (or Hooke's Law)

*May 16th, 1914.*

stress quadric to be drawn. These two quadrics will be coaxial.

We have three dynamical equations which give the whole dynamical relation between the stresses, and to which there is nothing to add. It is regarded, and the truth will appear from the paper, that these relations fix the characteristics of a stress quadric from the essentially dynamical basis, but that they do not determine its orientation. To complete the dynamical specification, I make the further hypothesis that this quadric shall be so oriented as to be coaxial with the strain and the elastic stress quadrics, and be drawn on the same scale as the latter. The strain quadric has now served its purpose and may be ignored. We remain with two coaxial stress quadrics, one the "elastic" stress quadric, the other the "dynamical" stress quadric.

Each is definite, and they are not identical except as the result of three further conditions of equality.

If we call the elements of the elastic stress

$$P', Q', R', S', T', U',$$

each is defined by Hooke's Law.

If the elements of the dynamical stress are

$$P, Q, R, S, T, U,$$

we have

$$\frac{\partial P}{\partial x} + \frac{\partial U}{\partial y} + \frac{\partial T}{\partial z} = 0,$$

$$\frac{\partial U}{\partial x} + \frac{\partial Q}{\partial y} + \frac{\partial S}{\partial z} = 0,$$

$$\frac{\partial T}{\partial x} + \frac{\partial S}{\partial y} + \frac{\partial R}{\partial z} = 0,$$

or

$$P = -\frac{\partial^2 \Theta_3}{\partial y^2} - \frac{\partial^2 \Theta_2}{\partial z^2},$$

$$Q = -\frac{\partial^2 \Theta_1}{\partial z^2} - \frac{\partial^2 \Theta_3}{\partial x^2},$$

$$R = -\frac{\partial^2 \Theta_2}{\partial x^2} - \frac{\partial^2 \Theta_1}{\partial y^2},$$

$$S = \frac{\partial^2 \Theta_1}{\partial y \partial z},$$

$$T = \frac{\partial^2 \Theta_2}{\partial x \partial z},$$

$$U = \frac{\partial^2 \Theta_3}{\partial x \partial y}.$$

The further hypothesis is

$$S/S' = T/T' = U/U' = \mathbf{1},$$

or

$$\frac{\partial^2 \Theta_1}{\partial y \partial z} = n \left( \frac{\partial w}{\partial y} + \frac{\partial v}{\partial z} \right),$$

$$\frac{\partial^2 \Theta_2}{\partial x \partial z} = n \left( \frac{\partial u}{\partial z} + \frac{\partial w}{\partial x} \right),$$

$$\frac{\partial^2 \Theta_3}{\partial x \partial y} = n \left( \frac{\partial v}{\partial x} + \frac{\partial u}{\partial y} \right).$$

The simplest mode of looking on these relations is to regard them as giving  $u, v, w$ . Thus

$$2nu = \frac{\partial}{\partial x} (\Theta_2 + \Theta_3 - \Theta_1),$$

$$2nv = \frac{\partial}{\partial y} (\Theta_3 + \Theta_1 - \Theta_2),$$

$$2nw = \frac{\partial}{\partial z} (\Theta_1 + \Theta_2 - \Theta_3).$$

At any rate we have two specifications, one for  $P, Q, R$ , on dynamical principles and one for  $P', Q', R'$  given by Hooke's Law.

A very great simplicity results from this mode of treatment whatever view may be held in regard to the nomenclature.

1. The dynamical equations can be looked upon as solved.

2. The forms of displacement are found.

3. The analytical results arising from Hooke's Law are obtained by simple processes.

The subject treated is one in which analytical simplification is greatly to be desired, and it appears that some of the existing complexities have arisen from the substitution of the six quantities  $P'$ ,  $Q'$ ,  $R'$ ,  $S'$ ,  $T'$ ,  $U'$  in the three dynamical equations, and any simplifications which this paper proposes arise from an alteration of method which does not necessarily depend on nomenclature nor upon the ideas which have seemed useful to me.

(ii.) There is a further suggestion in the paper of which it is requisite that I should give an explanation. This is the suggestion that the comparison of the two specifications for stress should be made use of as a test.

The exposition by Green of elastic stress in terms of strain is a full exposition of the relations within a substance of unlimited extent, but it is not clear that the relations so determined will hold good up to and at the boundaries of a restricted body. In dealing with a specific case, the process suggested is to determine separately each specification of stress so as to satisfy the surface conditions, and, *after that stage has been completed*, to examine whether the two specifications can be made identical, not merely over the interior but up to and at the bounding surfaces.

If this condition cannot be satisfied, the next step would be to assume some rational form of discrepancy from Hooke's Law in order to locate the character of discrepancy existing, its position and its extent.

This may be a formidable task, but it is not more hopeless than the search for a specific solution by means of the accepted elastic displacement equations.

(iii.) In previous Parts of this paper I have discussed at

some length the mathematical forms necessarily imposed on solutions of the statical stress equations. In the present Part, I have found it possible to proceed without much reference to the earlier Parts.

In this Part I propose to deal also with elastic stresses for which the mathematical forms of expression are based on the hypothesis of Hooke's Law. On this basis it is fundamental that the stresses, which are of considerable and even of great magnitude, should appear as large multiples of strains which are themselves extremely minute and certainly not measurable by any direct observation. The large multipliers we call elastic constants. To form a mathematical theory it is presumed that the material is absolutely uniform in character, and that the strains are everywhere continuous. In fact, an ideal mathematical elastic material is presumed, and it must always be borne in mind that the elastic theory applies with accuracy only to such an ideal substance. When the results are taken to apply to ordinary material, we have to remember that such material is irregular and coarse-grained and differs in many ways from the ideal substance to which the theory actually applies.

It appears to be thought by some writers on the subject, that by proceeding to a higher degree of accuracy in the mathematical expressions for the strains, a closer representation of the actual state of a natural body under stress might be obtained. The notion seems to me fundamentally wrong and fallacious if it is supposed that by introducing still more minute terms in the expression for the strains in the ideal substance, any closer approximation can be made to the conditions in the natural substances. A further refinement in the mathematical expressions including terms of a higher order should be deferred until the terms of the first order have been

shown to agree with the phenomena which they propose to describe in natural materials.

(iv.) I add references to papers which I have previously communicated to the Society, in which I have approached the point of view from which the present paper has been written.

1. Permanent Forms of Mathematical Expressions.

*Manchester Memoirs*, vol. xxxix. (1895), No. 8, p. 119.

2. Rate of propagation of an Earth-Tremor.

*Manchester Memoirs*, vol. xlvi. (1902), No. 15.

3. Conditions that Stresses should be Elastic.

*Manchester Memoirs*, vol. lv. (1911), No. 20.

4. Specification of Elements of Stress.

*Manchester Memoirs*, vol. lvi. (1912), No. 10.

5. Specification of Elements of Stress. Part II.

*Manchester Memoirs*, vol. lvii. (1913), No. 5.

### CARTESIAN COORDINATES.

- I. The dynamical stress equations are :

$$\begin{aligned} \frac{\partial P}{\partial x} + \frac{\partial U}{\partial y} + \frac{\partial T}{\partial z} &= \rho \ddot{u}, \\ \frac{\partial U}{\partial x} + \frac{\partial Q}{\partial y} + \frac{\partial S}{\partial z} &= \rho \ddot{v}, \\ \frac{\partial T}{\partial x} + \frac{\partial S}{\partial y} + \frac{\partial R}{\partial z} &= \rho \ddot{w}. \end{aligned} \quad \dots \dots \dots (1).$$

Whatever values  $u$ ,  $v$ ,  $w$  may have, we may always write

$$\begin{aligned} u &= \frac{\partial \Theta_1}{\partial x}, \\ v &= \frac{\partial \Theta_2}{\partial y}, \\ w &= \frac{\partial \Theta_3}{\partial z} \end{aligned} \quad \dots \dots \dots (2).$$

Also, whatever values  $S$ ,  $T$ , and  $U$  may have, we can always write

$$\begin{aligned}
 S &= \frac{\partial^2 \Psi_1}{\partial x \partial z}, \\
 T &= \frac{\partial^2 \Psi_2}{\partial x \partial z}, \\
 U &= \frac{\partial^2 \Psi_3}{\partial x \partial y} \dots \dots \dots (3).
 \end{aligned}$$

And we therefore shall always have formally

$$\begin{aligned}
 T - \rho \ddot{\Theta}_1 + \frac{\partial^2 \Psi_3}{\partial y^2} + \frac{\partial^2 \Psi_2}{\partial z^2} &= 0, \\
 Q - \rho \ddot{\Theta}_2 + \frac{\partial^2 \Psi_3}{\partial x^2} + \frac{\partial^2 \Psi_1}{\partial z^2} &= 0, \\
 R - \rho \ddot{\Theta}_3 + \frac{\partial^2 \Psi_2}{\partial x^2} + \frac{\partial^2 \Psi_1}{\partial y^2} &= 0 \dots \dots \dots (4).
 \end{aligned}$$

2. The elements of the stress consequent on Hooke's Law in a homogeneous isotropic elastic solid become, on the substitution for the components of the displacement given in (2),

$$P' = (m - n) \left( \frac{\partial^2 \Theta_1}{\partial x^2} + \frac{\partial^2 \Theta_2}{\partial y^2} + \frac{\partial^2 \Theta_3}{\partial z^2} \right) + 2n \frac{\partial^2 \Theta_1}{\partial x^2}$$

with two analogous expressions for  $Q'$  and  $R'$ ,

$$S' = n \frac{\partial^2}{\partial y \partial z} (\Theta_2 + \Theta_3)$$

with two analogous expressions for  $T'$  and  $U'$  . . . (5).

3. In order to make a connection between these two specifications of stress I shall assume

$$\begin{aligned}
 \Psi_1 &= n(\Theta_2 + \Theta_3), \\
 \Psi_2 &= n(\Theta_1 + \Theta_3), \\
 \Psi_3 &= n(\Theta_1 + \Theta_2) \dots \dots \dots (6).
 \end{aligned}$$

This connection is sufficient, and is not redundant.

The consequence is that

$$S' = S, \quad T' = T, \quad U' = U,$$

and that we have specifications which differ in form for  $P$  and  $P'$ ,  $Q$  and  $Q'$ ,  $R$  and  $R'$ .

Thus

$$P = \rho \ddot{\Theta}_1 - n \left\{ \frac{\hat{c}^2}{\hat{c}Q^2} (\Theta_1 + \Theta_2) + \frac{\hat{c}^2}{\hat{c}^2} (\Theta_1 + \Theta_2) \right\},$$

with two analogous expressions for  $Q$  and  $R$  . . . (7),

and

$$P' = (m - n) \left\{ \frac{\hat{c}^2 \Theta_1}{\hat{c}A^2} + \frac{\hat{c}^2 \Theta_2}{\hat{c}Q^2} + \frac{\hat{c}^2 \Theta_3}{\hat{c}^2} \right\} + 2n \frac{\hat{c}^2 \Theta_1}{\hat{c}A^2},$$

with two analogous expressions for  $Q'$  and  $R'$  . . . (8).

4. If we propose to draw the full conclusions consequent from the fulfilment of Hooke's law, we proceed to postulate the identity of the expressions for  $P$  and  $P'$ ,  $Q$  and  $Q'$ ,  $R$  and  $R'$ . But the assumption that the differences between the values of  $P$  and  $P'$ ,  $Q$  and  $Q'$ ,  $R$  and  $R'$  are small compared with  $P$ ,  $Q$  and  $R$  respectively is more in accordance with the object of attaining a description of physical phenomena. It is not proposed, it appears to be unreasonable, to require that the ratio of the differences of these stresses to the stresses themselves should be so minute as to be comparable with that of the second powers of the elements of strain to the first. The difference corresponds much more closely with a variation in the multipliers which we have spoken of as "elastic constants." Accordingly, the elastic theory is here considered as a rough approximation to a natural theory.

Before a closer approximation is taken into consideration, it is desirable to review the assumptions which have already been made.

Briefly, we have treated

$$\frac{\hat{c}}{\hat{c}x} (\rho \ddot{\Theta}_1)$$

as identical with

$$\rho \frac{\hat{c} \ddot{\Theta}_1}{\hat{c}x}, \text{ etc. . . . . } (a)$$



and

$$\frac{\partial^2}{\partial x^2} \left\{ n(\Theta_2 + \Theta_3) \right\}$$

as identical with

$$n \frac{\partial^2}{\partial y^2} (\Theta_2 + \Theta_3), \text{ etc. . . . . (b)}$$

we treat  $P'$  as identical with  $P$ , etc. . . . . (c)

and in the integration of the resulting equations the multipliers  $m$  and  $n$  are treated as constants.

Since the relative variations of  $\rho$  and  $m$  and  $n$  may reasonably be considered as possibly greater than the ratio  $\frac{du}{dx} : 1$ , the terms arising from these variations should be considered before the results of a further expansion of the displacement should be considered in the mathematical expressions.

5. If we now equate  $P'$  and  $P$ ,  $Q'$  and  $Q$ ,  $R'$  and  $R$ , we readily obtain

$$n \left( \frac{\partial^2}{\partial x^2} + \frac{\partial^2}{\partial y^2} + \frac{\partial^2}{\partial z^2} \right) \Theta_1 + m \left( \frac{\partial^2 \Theta_1}{\partial x^2} + \frac{\partial^2 \Theta_2}{\partial y^2} + \frac{\partial^2 \Theta_3}{\partial z^2} \right) = \rho \ddot{\Theta}_1,$$

and two analogous equations . . . . . (9).

Before making any modifications in these equations, it is well to review the analytical character of the assumptions that have been employed.

Neither

$$u = \frac{\partial \Theta}{\partial x}, \quad v = \frac{\partial \Theta}{\partial y}, \quad w = \frac{\partial \Theta}{\partial z},$$

nor

$$S = S', \quad T = T', \quad U = T'',$$

are relations which would preserve the same analytical form on change of the directions of the co-ordinate axes. In the resulting equations the outstanding characteristic is that  $\rho \ddot{\Theta}_1$ ,  $\rho \ddot{\Theta}_2$ ,  $\rho \ddot{\Theta}_3$  have the character of normal stresses.

Having made these remarks, I return to (2) and put

$$\Theta_1 = F + \mu_1, \quad \Theta_2 = F + \mu_2, \quad \Theta_3 = F + \mu_3, \quad . . . (10),$$

$$u = \frac{\partial}{\partial X} (F + \mu_1), \text{ etc.,}$$

and therefore

$$\frac{\partial u}{\partial X} + \frac{\partial v}{\partial Y} + \frac{\partial w}{\partial Z} = \left( \frac{\partial^2}{\partial X^2} + \frac{\partial^2}{\partial Y^2} + \frac{\partial^2}{\partial Z^2} \right) F + \left( \frac{\partial^2 \mu_1}{\partial X^2} + \frac{\partial^2 \mu_2}{\partial Y^2} + \frac{\partial^2 \mu_3}{\partial Z^2} \right).$$

We may, from principles of continuity, determine that  $F$  shall have such a value that

$$\frac{\partial^2 \mu_1}{\partial X^2} + \frac{\partial^2 \mu_2}{\partial Y^2} + \frac{\partial^2 \mu_3}{\partial Z^2} = 0, \quad \dots \dots \dots (11),$$

so that the whole "condensation" is confined to  $F$ . We may then re-write (9) in the form

$$(m + n)\nabla^2 F + n\nabla^2 \mu_1 = \rho(\ddot{F} + \ddot{\mu}_1)$$

with two analogous equations . . . . . (12).

These equations may otherwise be written

$$\rho\ddot{F} - (m + n)\nabla^2 F + \rho\ddot{\mu}_1 - n\nabla^2 \mu_1 = 0$$

and this form repeats itself for other coordinate systems. They will be considered at length in the following Part.

It has been part of the object of this investigation to make stresses rather than displacements the chief object, and to make use of displacements only as far as they must necessarily be made use of.

### 6. *Viscous forces.*

On the usual theory, the inclusion of viscous forces in addition to elastic forces, only requires that in the equations throughout,  $n$  should be replaced by

$$\left( n + \nu \frac{\partial}{\partial t} \right) \text{ and } m \text{ by } \left( m + \frac{1}{3} \nu \frac{\partial}{\partial t} \right).$$

This alteration may be introduced in the final results, as it will make no essential difference in the mode of procedure described.

7. *Elemental couples.*

If the motion of an element of the material under consideration is regarded in its widest aspect, and without any limitation from habit or from casual experience, the further possibility must be included of an elemental couple in the stress and of an elemental change of angular momentum in the material.

In the accepted theory it is assumed that either no such elemental couple exists, or that if it does exist it contributes no term to the work done on the element. It is now proposed to include the consideration of such a couple, and to examine more closely the reasons for its admission or inclusion.

It will therefore be taken that the stresses are, following an accepted notation,

$$\begin{aligned} p_{xx} &= P, & p_{yy} &= Q, & p_{zz} &= R, \\ p_{zy} &= S + \xi, & p_{yz} &= S - \xi, \\ p_{xz} &= T + \eta, & p_{zx} &= T - \eta, \\ p_{yx} &= U + \zeta, & p_{xy} &= U - \zeta \dots \dots \dots (13), \end{aligned}$$

so that the elemental couple is measured by

$$2\xi, \quad 2\eta, \quad 2\zeta, \dots \dots \dots (14),$$

and the linear force on the element has the components

$$\begin{aligned} \frac{\partial P}{\partial x} + \frac{\partial U}{\partial y} + \frac{\partial T}{\partial z} + \frac{\partial \zeta}{\partial y} - \frac{\partial \eta}{\partial z}, \\ \frac{\partial U}{\partial x} + \frac{\partial Q}{\partial y} + \frac{\partial S}{\partial z} + \frac{\partial \xi}{\partial z} - \frac{\partial \zeta}{\partial x}, \\ \frac{\partial T}{\partial x} + \frac{\partial S}{\partial y} + \frac{\partial R}{\partial z} + \frac{\partial \eta}{\partial x} - \frac{\partial \xi}{\partial y} \dots \dots \dots (15). \end{aligned}$$

In accordance, I shall write the components of the displacement as

$$\begin{aligned} u &= u_0 + \frac{\partial \Psi_3}{\partial y} - \frac{\partial \Psi_2}{\partial z}, \\ v &= v_0 + \frac{\partial \Psi_1}{\partial z} - \frac{\partial \Psi_3}{\partial x}, \end{aligned}$$

$$\tau v = \tau v_n + \frac{\partial \Psi_1}{\partial x} - \frac{\partial \Psi_2}{\partial y} \dots \dots \dots (16),$$

or

$$\begin{aligned} u &= \frac{\partial \Theta_1}{\partial x} + \frac{\partial \Psi_2}{\partial y} - \frac{\partial \Psi_3}{\partial z}, \\ v &= \frac{\partial \Theta_2}{\partial y} + \frac{\partial \Psi_1}{\partial z} - \frac{\partial \Psi_3}{\partial x}, \\ x &= \frac{\partial \Theta_3}{\partial z} + \frac{\partial \Psi_2}{\partial x} - \frac{\partial \Psi_1}{\partial y} \dots \dots \dots (17), \end{aligned}$$

where just as we have connected  $\ddot{\Theta}_1, \ddot{\Theta}_2, \ddot{\Theta}_3$  with effective normal stresses, we must now treat  $\ddot{\Psi}_1, \ddot{\Psi}_2, \ddot{\Psi}_3$  as having the character of effective shearing stresses, so that for the rotational equilibrium of the element we must have

$$\xi = \rho \ddot{\Psi}_1, \quad \eta = \rho \ddot{\Psi}_2, \quad \zeta = \rho \ddot{\Psi}_3 \dots \dots \dots (18).$$

Similarly for the linear equilibrium of the element, making use of this relation, we shall have

$$\begin{aligned} \frac{\partial P}{\partial x} + \frac{\partial U}{\partial y} + \frac{\partial T}{\partial z} &= \rho \frac{\partial \ddot{\Theta}_1}{\partial x}, \\ \frac{\partial U}{\partial x} + \frac{\partial Q}{\partial y} + \frac{\partial S}{\partial z} &= \rho \frac{\partial \ddot{\Theta}_2}{\partial y}, \\ \frac{\partial T}{\partial x} + \frac{\partial S}{\partial y} + \frac{\partial R}{\partial z} &= \rho \frac{\partial \ddot{\Theta}_3}{\partial z} \dots \dots \dots (19). \end{aligned}$$

Returning now to the elastic specification of stress, the elements  $P, Q, R, S, T, U$  are given in terms of  $\Theta_1, \Theta_2, \Theta_3, \Psi_1, \Psi_2,$  and  $\Psi_3$ , while the right-hand side of (19) is given in terms of  $\Theta_1, \Theta_2, \Theta_3$  only.

It is, however, necessary to consider  $\xi, \eta, \zeta$ . In the usual theory, the values to be given to these quantities are not discussed, but if we follow the course indicated by Green in his analysis of the elastic relations, and find the expressions for stresses as following from terms from the work done, which work must be an invariational expression

of the first differential coefficients of the displacement, we find

$$\begin{aligned} \xi &= k \left( \frac{\partial w}{\partial y} - \frac{\partial z}{\partial z} \right), \\ \eta &= k \left( \frac{\partial u}{\partial z} - \frac{\partial w}{\partial x} \right), \\ \zeta &= k \left( \frac{\partial v}{\partial x} - \frac{\partial u}{\partial y} \right) \dots \dots \dots (20), \end{aligned}$$

as the only possible relation, and it is subject to the tests which may be made as to the magnitude or existence of  $k$ .

The previous paragraphs have given the general outlines of the treatment of the question now proposed, and I shall only indicate the lines of adaptation.

In (17) write  $\Theta_1 = F + \mu_1$ , etc., and

$$\frac{\partial \Psi_3}{\partial y} - \frac{\partial \Psi_2}{\partial z} = \frac{\partial \mu_1'}{\partial x}, \text{ etc.},$$

so that

$$uu = \frac{\partial}{\partial x} (\phi + \mu_1 + \mu_1'), \text{ etc.}, \dots \dots \dots (21).$$

The specifications of stresses previously given will then apply to (19) if we replace  $F + \mu_1$  by  $F + \mu_1 + \mu_1'$  as far as the terms in which space-differentiation is concerned, and if we retain  $F + \mu_1$  in the terms in which time-differentiation is to be performed. The relations between  $\mu_1, \mu_2, \mu_3$  and  $\mu_1', \mu_2', \mu_3'$  are contained in (18) and (20), and it follows that

$$\rho \ddot{\Psi}_1 = k \left( \frac{\partial w}{\partial y} - \frac{\partial z}{\partial z} \right), \dots \dots \dots (22).$$

Hence

$$\rho \ddot{\Psi}_1 = \frac{k}{n} \frac{\partial^2}{\partial y \partial z} (\mu_3 - \mu_2 + \mu_3' - \mu_2'), \text{ etc.}$$

and therefore that

$$\rho \ddot{\mu}_1' = \frac{k}{n} \left\{ \frac{\partial^2}{\partial y^2} (\mu_2 - \mu_1 + \mu_2' - \mu_1') - \frac{\partial^2}{\partial z^2} (\mu_1 - \mu_3 + \mu_1' - \mu_3') \right\}, \text{ etc.} \quad (23).$$

If  $k$  were a constant of about the magnitude of  $n$ , the

elemental stress couple would play the main part in the general phenomena of stress and would not have escaped notice. It will, therefore, be supposed that  $k/n$  is small, and hence that

$$\begin{aligned} \rho \ddot{\mu}'_1 &= \frac{k}{n} \left\{ \frac{\partial^2}{\partial y^2} (\mu_2 - \mu_1) - \frac{\partial^2}{\partial z^2} (\mu_1 - \mu_3) \right\} \\ &= -\frac{k}{n} \nabla^2 \mu_1, \text{ etc. . . . . (24).} \end{aligned}$$

Finally, we obtain these relations :

$$\begin{aligned} u &= \frac{\partial}{\partial x} (F + \mu_1 + \mu'_1), \text{ etc., where} \\ \frac{\partial^2 \mu_1}{\partial x^2} + \frac{\partial^2 \mu_2}{\partial y^2} + \frac{\partial^2 \mu_3}{\partial z^2} &= 0, \end{aligned}$$

and where

$$\rho \ddot{\mu}'_1 + \frac{k}{n} \nabla^2 \mu_1 = 0, \text{ etc.,}$$

and where also

$$\rho \ddot{F} + \rho \ddot{\mu} = \left( m + n + \frac{1}{3} \nu \frac{\partial}{\partial t} \right) \Delta^2 F + \left( n + \nu \frac{\partial}{\partial t} \right) \Delta^2 (\mu + \mu')$$

which represents the type of three equations with the subscript numbers 1, 2, or 3, and which includes also the small viscous terms.

To eliminate  $\mu'$  requires further differentiation in time, and a type of equation is then obtained which may be the subject of further consideration in the hope of explaining some phenomena, such as elastic after strain.

### 8. *General case.*

Application of the method to the general case where the stresses are not identical with the ideal elastic stresses.

In order to develop the proposed method in as simple a form as possible, I have assumed up to the present that  $S = S'$ ,  $T = T'$ ,  $U = U'$  are completely satisfied, and have proposed that the equality of  $P$  and  $P'$ ,  $Q$  and  $Q'$ ,  $R$  and  $R'$  should be of the nature of a test.

I propose now to show that we are prepared to deal with the cases where no identity of the stresses is postulated.

Returning to the equations numbered from (1) to (5), and in (3), write

$$\begin{aligned}
 S &= \frac{\hat{c}^2(\Psi_1 + \psi_1)}{\hat{c}_Y \hat{c}_Z}, \\
 T &= \frac{\hat{c}^2(\Psi_2 + \psi_2)}{\hat{c}_X \hat{c}_Z}, \\
 U &= \frac{\hat{c}^2(\Psi_3 + \psi_3)}{\hat{c}_X \hat{c}_Y} \dots \dots \dots (25),
 \end{aligned}$$

while the relations (6) are retained, namely,

$$\Psi_1 = n(\Theta_2 + \Theta_3) \text{ etc.}$$

We thus obtain

$$\begin{aligned}
 S &= S' + \frac{\hat{c}^2 \psi_1}{\hat{c}_Y \hat{c}_Z}, \\
 T &= T' + \frac{\hat{c}^2 \psi_2}{\hat{c}_X \hat{c}_Z}, \\
 U &= U' + \frac{\hat{c}^2 \psi_3}{\hat{c}_X \hat{c}_Y} \dots \dots \dots (26).
 \end{aligned}$$

Also we find  $P$ ,  $Q$ , and  $R$  in the form of (27) which will replace (7), that is

$$\begin{aligned}
 P &= \rho \ddot{\Theta}_1 - n \left\{ \frac{\hat{c}^2}{\hat{c}_Y^2} (\Theta_1 + \Theta_2) + \frac{\hat{c}^2}{\hat{c}_Z^2} (\Theta_1 + \Theta_3) \right\} - \frac{\hat{c}^2 \psi_3}{\hat{c}_Y^2} - \frac{\hat{c}^2 \psi_2}{\hat{c}_Z^2}, \\
 &\text{etc.,} \dots \dots \dots (27),
 \end{aligned}$$

while the forms of  $P'$ ,  $Q'$ , and  $R'$  in (8) are unchanged.

This section is not intended to treat of the case when the stresses are functions of higher powers of the elements of strain. That case presents points of difference and will be dealt with in a subsequent Part.

CYLINDRICAL POLAR COORDINATES.

9. The dynamical stress equations are now

$$\begin{aligned} \frac{\partial P}{\partial r} + \frac{P-Q}{r} + \frac{1}{r} \frac{\partial U}{\partial \theta} + \frac{\partial T}{\partial z} &= \rho \ddot{u}, \\ \frac{\partial U}{\partial r} + \frac{2U}{r} + \frac{1}{r} \frac{\partial Q}{\partial \theta} + \frac{\partial S}{\partial z} &= \rho \ddot{v}, \\ \frac{\partial T}{\partial r} + \frac{T}{r} + \frac{1}{r} \frac{\partial S}{\partial \theta} + \frac{\partial R}{\partial z} &= \rho \ddot{w} \quad \dots \dots \dots (28). \end{aligned}$$

I am not able in this case to follow the simpler method adopted for Cartesian coordinates, and I have to make use of the solution of the statical equations corresponding to (13) which I have given in Part I., and simplified in Part II. of this series of papers.\*

The solutions take the form

$$\begin{aligned} P &= \frac{1}{r^2} \frac{\partial^2 \Theta_3}{\partial \theta^2} + \frac{\partial^2 \Theta_2}{\partial z^2} + \frac{1}{r} \frac{\partial \Theta_3}{\partial r}, \\ Q &= \frac{\partial^2 \Theta_3}{\partial r^2} + \frac{\partial^2 \Theta_1}{\partial z^2}, \\ R &= \frac{\partial^2 \Theta_2}{\partial r^2} + \frac{1}{r^2} \frac{\partial^2 \Theta_1}{\partial \theta^2} + \frac{2}{r} \frac{\partial \Theta_2}{\partial r} - \frac{1}{r} \frac{\partial \Theta_1}{\partial r}, \\ S &= -\frac{1}{r} \frac{\partial^2 \Theta_1}{\partial \theta \partial z}, \\ T &= -\frac{\partial^2 \Theta_2}{\partial r \partial z} + \frac{1}{r} \frac{\partial \Theta_1}{\partial z} - \frac{1}{r} \frac{\partial \Theta_2}{\partial z}, \\ U &= -\frac{1}{r} \frac{\partial^2 \Theta_3}{\partial r \partial \theta} + \frac{1}{r^2} \frac{\partial \Theta_3}{\partial \theta} \dots \dots \dots (29). \end{aligned}$$

10. The elastic specification of stress is as usual given by

$$P = (m-n) \left( \frac{\partial u}{\partial r} + \frac{u}{r} + \frac{1}{r} \frac{\partial v}{\partial \theta} + \frac{\partial w}{\partial z} \right) + 2u \frac{\partial u}{\partial r}$$

\*The simpler method which I have used for Cartesian has been so employed as an introductory method. That used for Polars, cylindrical and spherical, is the general method.



with two other equations, and

$$\begin{aligned} S' &= n \left( \frac{1}{r} \frac{\partial v}{\partial \theta} + \frac{\partial v}{\partial z} \right), \\ T' &= n \left( \frac{\partial u}{\partial z} + \frac{\partial v}{\partial r} \right), \\ U' &= n \left( \frac{\partial v}{\partial r} - \frac{v}{r} + \frac{1}{r} \frac{\partial u}{\partial \theta} \right) \dots \dots \dots (30). \end{aligned}$$

11. I now proceed as before to equate  $S$  and  $S'$ ,  $T$  and  $T'$ ,  $U$  and  $U'$ , but in this case it is with the object of finding whether and under what conditions a form of displacement can be discovered, such as will conform with the requirement.

Assuming, for convenience,

$$nv = \frac{1}{2} \frac{\partial}{\partial z} (\Theta_2 - \Theta_1 - \Theta_3)$$

we deduce

$$\begin{aligned} nv &= \frac{1}{2r} \frac{\partial}{\partial \theta} (\Theta_2 - \Theta_3 - \Theta_1) \\ nu &= \frac{1}{2} \frac{\partial}{\partial r} (\Theta_1 - \Theta_2 - \Theta_3) + \frac{\Theta_1 - \Theta_2}{r} \dots \dots \dots (31), \end{aligned}$$

from the equality of  $S$  and  $S'$ ,  $T$  and  $T'$ .

The equality of  $U$  and  $U'$  requires the condition that

$$\frac{\partial}{\partial z} (\Theta_1 - \Theta_2) = 0 \dots \dots \dots (32),$$

and, with this system of coordinates, it is possible for the relations to subsist together only if this condition is satisfied. This condition is therefore a consequence following on Hooke's Law.

12. The notation, which it has been found convenient to employ while dealing with the connection of the shearing stresses and the discovery of the form of displacement may now be replaced more conveniently by the assumptions

$$\begin{aligned} \Theta_1 - \Theta_2 - \Theta_3 &= 2(F + \mu_1), \\ \Theta_2 - \Theta_3 - \Theta_1 &= 2(F + \mu_2), \\ \Theta_3 - \Theta_1 - \Theta_2 &= 2(F + \mu_3), \end{aligned}$$

which brings the notation into accordance with that used for cartesian coordinates.

The strain represented by  $F$  is a "pure" strain, and the principle of continuity will justify us in requiring that the whole "condensation" is given by this strain, and consequently that

$$\frac{\partial^2 \mu_1}{\partial r^2} + \frac{1}{r} \frac{\partial(2\mu_1 - \mu_2)}{\partial r} + \frac{1}{r^2} \frac{\partial^2 \mu_2}{\partial \theta^2} + \frac{\partial^2 \mu_3}{\partial z^2} \dots \dots \dots (33).$$

The relations may now be written

$$\begin{aligned} nu &= \frac{\partial F}{\partial r} + \frac{\partial \mu_1}{\partial r} + \frac{\mu_1 - \mu_2}{r}, \\ n\tau &= \frac{1}{r} \frac{\partial F}{\partial \theta} + \frac{1}{r} \frac{\partial \mu_2}{\partial \theta}, \\ n\tau' &= \frac{\partial F}{\partial z} + \frac{\partial \mu_3}{\partial z}, \end{aligned}$$

with the condition

$$\frac{\partial(\mu_1 - \mu_2)}{\partial \theta} = 0 \dots \dots \dots (34).$$

$$\begin{aligned} P &= \frac{m-n}{n} \Delta^2 F + 2 \left( \frac{\partial^2 F}{\partial r^2} + \frac{\partial^2 \mu_1}{\partial r^2} + \frac{1}{r} \frac{\partial(\mu_1 - \mu_2)}{\partial r} - \frac{\mu_1 - \mu_2}{r^2} \right) \\ Q &= \frac{m-n}{n} \Delta^2 F + 2 \left( \frac{1}{r} \frac{\partial F}{\partial r} + \frac{1}{r^2} \frac{\partial^2 F}{\partial \theta^2} + \frac{1}{r} \frac{\partial \mu_1}{\partial r} + \frac{\mu_1 - \mu_2}{r^2} + \frac{1}{r^2} \frac{\partial^2 \mu_2}{\partial \theta^2} \right) \\ R &= \frac{m-n}{n} \Delta^2 F + 2 \left( \frac{\partial^2 F}{\partial z^2} + \frac{\partial^2 \mu_3}{\partial z^2} \right) \dots \dots \dots (35). \end{aligned}$$

$$\begin{aligned} P - \rho(\ddot{F} + \ddot{\mu}_1) + 2 \left( \frac{1}{r} \frac{\partial F}{\partial r} + \frac{1}{r^2} \frac{\partial^2 F}{\partial \theta^2} + \frac{\partial^2 F}{\partial z^2} \right) \\ + \frac{1}{r} \frac{\partial(\mu_1 + \mu_2)}{\partial r} + \frac{1}{r^2} \frac{\partial^2(\mu_1 + \mu_2)}{\partial \theta^2} + \frac{\partial^2}{\partial z^2}(\mu_1 + \mu_3) = 0. \\ Q - \rho(\ddot{F} + \ddot{\mu}_2) + 2 \left( \frac{\partial^2 F}{\partial r^2} + \frac{\partial^2 F}{\partial \theta^2} \right) + \frac{\partial^2}{\partial r^2}(\mu_1 + \mu_2) + \frac{\partial^2}{\partial z^2}(\mu_2 + \mu_3) = 0. \\ R - \rho(\ddot{F} + \ddot{\mu}_3) + 2 \left( \frac{\partial^2 F}{\partial r^2} + \frac{1}{r} \frac{\partial F}{\partial r} + \frac{1}{r^2} \frac{\partial^2 F}{\partial \theta^2} \right) + \frac{\partial^2(\mu_1 + \mu_3)}{\partial r^2} \\ + \frac{2}{r} \frac{\partial(\mu_1 + \mu_3)}{\partial r} + \frac{1}{r^2} \frac{\partial^2(\mu_2 + \mu_3)}{\partial \theta^2} - \frac{1}{r} \frac{\partial(\mu_2 + \mu_3)}{\partial r} = 0 \dots (36). \end{aligned}$$

By equating  $P$  and  $P'$ ,  $Q$  and  $Q'$ ,  $R$  and  $R'$ , we get equations of condition of the same form as in (12) where  $\nabla^2$  now stands for

$$\frac{\partial^2}{\partial r^2} + \frac{1}{r} \frac{\partial}{\partial r} + \frac{1}{r^2} \frac{\partial^2}{\partial \theta^2} + \frac{\partial^2}{\partial z^2}.$$

### SPHERICAL POLAR COORDINATES.

13. In the case of these coordinates, I pursue the course which I have followed in that of cylindrical coordinates.

In a previous paper read before the Society, I proposed for the case of spherical polar coordinates the notation  $u$ ,  $v \sin \theta$ ,  $w \sin \theta$  for the components of displacement, and in the previous Parts of this series of papers I have prepared the expressions for the different quantities which will enter on the supposition that this notation is used. The notation is made use of here also. Throughout  $x$  will be used to replace  $\cos \theta$ . It is necessary to give the equations in full.

#### *The Dynamical Stress Equations.*

In these equations the stresses are  $P$ ,  $Q$ ,  $R$ ,  $S$ ,  $T \sin \theta$ , and  $U \sin \theta$ , the elements of strain being  $e, f, g, a, b \sin \theta, c \sin \theta$ , so that  $T$ ,  $U$ ,  $b$  and  $c$  have not their usual significance.

The resulting equations are

$$\begin{aligned} \frac{\partial P}{\partial r} + \frac{2P - Q - R}{r} - \frac{1}{r} \frac{\partial}{\partial x} \{ (1 - x^2) U \} + \frac{1}{r} \frac{\partial T}{\partial \phi} &= \rho \ddot{u}, \\ \frac{\partial U}{\partial r} + \frac{3U}{r} - \frac{1}{r} \left\{ \frac{\partial Q}{\partial x} - \frac{(Q - R)x}{1 - x^2} \right\} + \frac{1}{r(1 - x^2)} \frac{\partial S}{\partial \phi} &= \rho \ddot{v}, \\ \frac{\partial T}{\partial r} + \frac{3T}{r} - \frac{1}{r(1 - x^2)} \frac{\partial}{\partial x} \{ (1 - x^2) S \} + \frac{1}{r(1 - x^2)} \frac{\partial R}{\partial \phi} &= \rho \ddot{w}. \quad (37). \end{aligned}$$

The solutions which I have given of the corresponding statical equations are

$$\begin{aligned}
 P &= \frac{1-x^2}{r^2} \frac{\partial^2 \Theta_3}{\partial x^2} + \frac{1}{r^2(1-x^2)} \frac{\partial^2 \Theta_2}{\partial \phi^2} + \frac{1}{r} \frac{\partial(\Theta_2 + \Theta_3)}{\partial r} \\
 &\quad + \frac{x}{r^2} \frac{\partial}{\partial x} (\Theta_2 - 3\Theta_3) + \frac{2(\Theta_2 - \Theta_1)}{r^2}, \\
 Q &= \frac{\partial^2 \Theta_3}{\partial r^2} + \frac{1}{r^2(1-x^2)} \frac{\partial^2 \Theta_1}{\partial \phi^2} + \frac{1}{r} \frac{\partial(2\Theta_3 - \Theta_1)}{\partial r} - \frac{x}{r^2} \frac{\partial \Theta_1}{\partial x}, \\
 R &= \frac{\partial^2 \Theta_2}{\partial r^2} + \frac{1-x^2}{r^2} \frac{\partial^2 \Theta_1}{\partial x^2} + \frac{1}{r} \frac{\partial(2\Theta_2 - \Theta_1)}{\partial r} - \frac{x}{r^2} \frac{\partial \Theta_1}{\partial x}, \\
 S &= \frac{1}{r^2} \frac{\partial^2 \Theta_1}{\partial x \partial \phi} + \frac{x}{r^2(1-x^2)} \frac{\partial \Theta_1}{\partial \phi}, \\
 T &= -\frac{1}{r(1-x^2)} \frac{\partial^2 \Theta_2}{\partial r \partial \phi} + \frac{1}{r^2(1-x^2)} \frac{\partial \Theta_1}{\partial \phi}, \\
 U &= \frac{1}{r} \frac{\partial^2 \Theta_3}{\partial r \partial x} + \frac{x}{r(1-x^2)} \frac{\partial(\Theta_2 - \Theta_3)}{\partial r} - \frac{1}{r^2} \frac{\partial \Theta_1}{\partial x} \dots \dots \dots (38).
 \end{aligned}$$

Also with the same notation

$$e = \frac{\partial u}{\partial r}, \quad f = \frac{1}{r} \left\{ u + xv - (1-x^2) \frac{\partial v}{\partial x} \right\}, \quad g = \frac{1}{r} \left( u + xv + \frac{\partial w}{\partial \phi} \right)$$

and

$$\begin{aligned}
 a &= \frac{1}{r} \left( \frac{\partial v}{\partial \phi} - (1-x^2) \frac{\partial w}{\partial x} \right), \\
 b &= \frac{1}{r} \left( \frac{1}{1-x^2} \frac{\partial u}{\partial \phi} + r \frac{\partial w}{\partial r} - w \right), \\
 c &= \frac{1}{r} \left( r \frac{\partial v}{\partial r} - v - \frac{\partial u}{\partial x} \right) \dots \dots \dots (39).
 \end{aligned}$$

Having given these expressions it will not be necessary to write  $P'$ ,  $Q'$ ,  $R'$  in full.

14. As before we equate  $S$  to  $na$ ,  $T$  to  $nb$ ,  $S$  to  $nc$ , and by a precisely similar analysis we find

$$\begin{aligned}
 nu &= \frac{1}{2} \frac{\partial}{\partial r} (\Theta_1 - \Theta_2 - \Theta_3) - \frac{\Theta_2 - \Theta_3}{r}, \\
 nv &= -\frac{1}{2r} \frac{\partial}{\partial x} (\Theta_2 - \Theta_3 - \Theta_1) - \frac{x(\Theta_2 - \Theta_3)}{r(1-x^2)}, \\
 nw &= \frac{1}{2r(1-x^2)} \frac{\partial}{\partial \phi} (\Theta_3 - \Theta_1 - \Theta_2) \dots \dots \dots (40),
 \end{aligned}$$

subject to the condition

$$\frac{x}{1-x^2} \frac{\partial}{\partial r} \left( \frac{\Theta_2 - \Theta_3}{r} \right) = \frac{1}{r} \frac{\partial}{\partial x} \left( \frac{\Theta_2 - \Theta_3}{r} \right)$$

or 
$$\frac{\Theta_2 - \Theta_3}{r} = f\left(\frac{\sin \theta}{r}\right) \dots \dots \dots (41).$$

As in the previous case we put

$$\Theta_1 - \Theta_2 - \Theta_3 = 2(F + \mu_1), \text{ etc.},$$

and get

$$nu = \frac{\partial F}{\partial r} + \frac{\partial \mu_1}{\partial r} - \frac{\mu_2 - \mu_3}{r},$$

$$nv = -\frac{1}{r} \frac{\partial F}{\partial x} - \frac{1}{r} \frac{\partial \mu_2}{\partial x} - \frac{x(\mu_2 - \mu_3)}{r(1-x^2)},$$

$$nw = \frac{1}{r(1-x^2)} \frac{\partial F}{\partial \phi} + \frac{1}{r(1-x^2)} \frac{\partial \mu_3}{\partial \phi},$$

where

$$\begin{aligned} & \frac{\partial^2 \mu_1}{\partial r^2} + \frac{2}{r} \frac{\partial \mu_1}{\partial r} - \frac{2x}{r^2} \frac{\partial \mu_2}{\partial x} + \frac{1-x^2}{x^2} \frac{\partial \mu_2}{\partial x^2} \\ & - \frac{1}{r} \frac{\partial}{\partial r} (\mu_2 - \mu_3) + \frac{x}{r} \frac{\partial}{\partial x} (\mu_2 - \mu_3) - \frac{2x^2}{1-x^2} \frac{(\mu_2 - \mu_3)}{r^2} = 0 \end{aligned} \quad (42),$$

and subject to the conditional equation (41).

The equations of condition to satisfy Hooke's Law are again of the form stated in (12), which applies to all coordinate systems.



## VI. How does the Plant obtain its nutriment from the soil?

By A. D. HALL, M.A., F.R.S.

*(Special lecture, March 4th, 1913.)*

*(Received for publication January 12th, 1914.)*

The theory of the nutrition of the plant may be said to begin with the discovery that the plant draws but a small portion of its substance from the soil, though from that source alone it derives certain elements—in particular nitrogen, phosphorus, and potassium—without which growth will not take place. Moreover, it was early shown that the compounds thus supplied by the soil must be in a state of solution before they can reach the plant, so that the source of nutriment is that body of water which clings by surface tension to the particles of the soil—a body which, though subject to considerable fluctuations through its irregular depletion and renewal, is a permanent element in the soil. This water contains, amongst other materials, nitrates, phosphoric acid and potash salts, derived from the solid materials of the soil; it serves as the intermediary whereby they are passed on to the plant and is conveniently described as the soil solution.

Early in the history of agricultural science it was realised that the soil itself contains a considerable stock of the essential nutrients—nitrogen, phosphoric acid and potash, so that it was difficult to understand why the ordinary crop should ever be so short of these substances that any further supply in the form of a fertiliser could

*May 25th, 1914.*

increase the yield. For example, a soil of less than average fertility will contain 2,500 lb. of phosphoric acid per acre in the surface layer down to a depth of nine inches only, yet the crop of turnips will be very small unless the soil is further supplied with 50 lb. per acre of phosphoric acid in the shape of superphosphate, though an ordinary full crop would contain no more than 30 lb. of phosphoric acid per acre. In the light of these facts Daubeny, as early as 1845, introduced a distinction between the dormant and active plant food in the soil, the latter being the nitrogen, phosphoric acid and potash that are combined in such soluble forms as to be available for crop production. Nitrogen compounds in the soil have to be resolved into ammonia and nitrates by bacterial action before the plant can use them, and the rate at which this change will take place depends upon a number of factors, such as warmth, the amount of air and water in the soil, the supply of lime, that are independent of the total nitrogen supply in the soil. Daubeny even attempted to discriminate between the dormant and active phosphoric acid and potash by estimating the amount of these constituents that would dissolve in a very weak acid solution, but this method for determining the proportion of active mineral plant food, though it received a wide extension by the work of Dyer in 1894, has failed to yield the information expected of it. Speaking generally, analysis has failed to measure the productivity of an unknown soil except in the most general way, because it always reveals such an excess of the essential nutriments over the amount the crop can utilise.

A fresh point of view was introduced in 1903 by Whitney and Cameron, the investigators in charge of the Bureau of Soils of the United States Depart-



ment of Agriculture. Leaving out of account for the moment the nitrogen compounds, they argued that all soils are known to contain much the same compounds of phosphoric acid and potash, in the former case combinations with lime, iron and alumina, while potash finds its place in certain complex hydrated double silicates of alumina and the alkalis and alkaline earths. All these compounds possess a low solubility, so low that the amount of the solids present in any soil is always sufficient to saturate the water contained in the soil. It may be considered as established that plants draw their nutriment only from the soil solution thus formed, and are not capable of feeding directly upon solid compounds of phosphoric acid and potash. Thus it would be a matter of indifference to the plant whether the soil contained 0.2% or 0.05% of phosphoric acid; in either case the soil solution would be saturated with phosphoric acid, *i.e.*, it would contain the maximum amount in the dissolved state that is in equilibrium with the solid compounds in the soil, which *ex hypothesi* in all soils are identical in kind though not in quantity. All soils then should give rise to a soil solution of equal concentration in phosphoric acid and potash, and should have as regards these constituents equal feeding powers for the crop. Moreover, the addition of soluble phosphates or potash compounds in the form of fertilisers should not sensibly disturb the composition of the soil solution, for the added soluble material will, as is known, at once react with the bases in the soil and pass into compounds identical with those already existing in the soil, thus effecting no permanent change in the concentration of the soil solution. The cardinal feature of Whitney and Cameron's theory, then, is that all soils must give rise to a soil solution of practically constant composition. Furthermore, they argued on the basis of

recorded experiments that the growth of the plant is independent of variations in the composition of the soil solution, that provided, for example, there is some phosphoric acid in solution the plant will obtain all it can utilise whether the concentration is 3 or 300 parts per million. From these considerations they concluded that neither the amount of phosphoric acid and potash in the soil nor the further supply in fertilisers are direct factors in the nutrition of the crop, as is usually supposed. Since, however, it cannot be denied that fertilisers have some beneficial effect upon the crop, another mode of action must be found for them, and Whitney and Cameron had recourse to a theory originally suggested by de Candolle that plants excrete and leave behind in the soil certain substances toxic to themselves that will depress the renewed growth of the same plant in the same soil. From this it would follow that a judicious rotation, by giving time for the specific toxin to decay before the particular crop comes round again, would be as effective as a fertiliser in maintaining the productivity of the soil. The fertilisers act by precipitating, or otherwise putting out of action, these toxins.

Many considerations make it difficult to accept so novel a theory, but as the argument for a soil solution of constant composition is a logical if too hard and fast a deduction from accepted facts, it was decided to submit it to the test of direct experiment.

#### EXPERIMENTAL.

The first line of attack was to test the nutritive power of actual soil solutions derived from soils of known origin, and accordingly solutions were made up from soils selected from the wheat and barley plots at Rothamsted, which had been growing these crops without break for

the last half-century or more and had received the same manurial treatment every year. The soil was taken fresh from the field, added to such a volume of water as would produce a mixture of 20 kilos dry soil and 35 kilos water, left for a day and the solution filtered off. Pure lines (to secure uniformity) of wheat and barley were grown in these solutions, ten plants of each being grown in the solution from each soil, and the solutions were renewed fortnightly to ensure that the food supply was always adequate. In order to confine the problem to the mineral constituents only of the soils, the same amount of nitrate of soda was added to each solution. From the outset, growth proceeded much more vigorously in some solutions than in others, the best plants being those growing in the solutions from the soils that had been continuously manured.

Table I. gives the average yield during the last ten years on the plots from which the soils were taken. Table II. gives the average weight of the wheat and barley plants growing in the solution, while the diagram, *Text-fig. 1*, shows a comparison of the growth in the solution with that in the field.

There can be no mistake about the significance of these results: the growth in the solutions is strictly parallel to the growth in the same soils in the field, if an allowance is made for the nitrogen supplied to the solution from the unmanured soil, which receives no nitrogen in the field. The growths are such as would be expected from the known history of the plots, and do not agree with the idea that all soils yield solutions of the same nutritive power.

The solutions themselves were next analysed with the results set out in Table III., where also the analyses of the soils are added for comparison. The composition of

the solutions was found to vary in accordance with the history and composition of the soils, and the growth in the solutions is such as might be expected from their composition.

A second set of experiments was then started in which the deficiencies in the solutions from the unmanured and partially manured soils were repaired by the addition of phosphoric acid and potash, with the results set out in

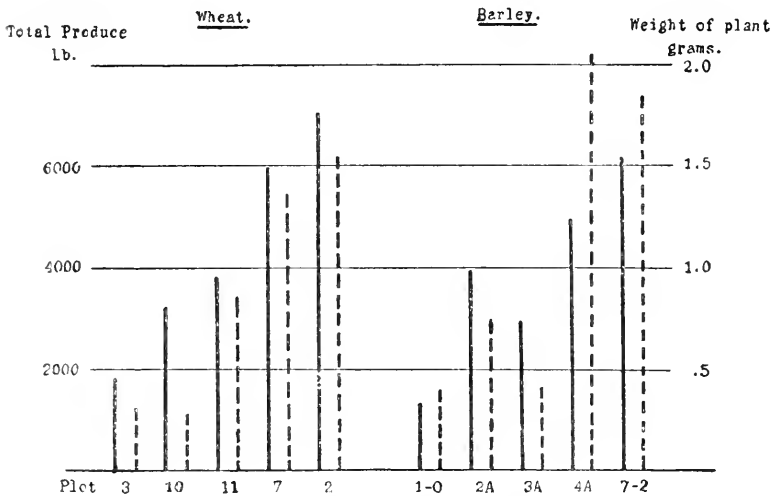

*Text-fig. 1.* Comparative yield of the crops in the field (solid lines) and of the plants in the solutions from the same soils (dotted lines).

Table IV. As wheat and barley had given identical results in the first trials, the later experiments were confined to barley.

From these figures it will be seen that the artificial culture solution, which was calculated to be approximately equivalent to the soil solutions yielded by the completely manured plots 4A and 7/2, yielded plants whose weight (0.763) was distinctly lower but of the same order as those grown in the soil solutions

from the completely manured plots (0.963 and 1.465). The artificial culture solution of high concentration yielded heavier plants (0.943), approaching those obtained in the solutions from the completely manured soils, though still below the maximum. The soil solutions from the unmanured (1.0) and imperfectly manured plots (2A) yielded plants of a much lower order of magnitude (0.216 and 0.486). The addition of the missing nutrients to the solutions from the imperfectly manured soils produced growth approaching the maximum (1.214 and 1.154); when the nutrients were added to set up the higher concentration the growth produced was equal to that obtained from the artificial culture solution of the same concentration (0.974 and 0.925 against 0.943), though still below the maximum. These results amply confirm the conclusion drawn from the previous set of experiments—that the growth of plants in the soil solutions is in the main determined by the amount of plant food they contain. One other point was suggested by the results, that the soil solutions, particularly those from the soil of the dunged plot, were better media for growth than the artificial culture solutions of equivalent concentration, possibly owing to the presence of soluble nitrogen compounds specially valuable to the plant in the earlier stages of growth. On the other hand it is unsafe to lay much stress on such differences in weight as were exhibited in the growth of the plants in the solutions regarded as complete (0.943, 1.214, 0.974, 1.154, 0.925, 0.963, 1.349, 1.465, 1.286).

In order to check the conclusions still further a third series of experiments were made. A solution containing per million 4.5 of phosphoric acid and 26.5 of potash was taken as a standard, this being the approximate composition of the solutions of soils from the completely

manured plots of the barley fields 4A and 7/2. To the solutions from the imperfectly manured plots (1,0, 2A, 3A), phosphoric acid and potash were added in amounts required to bring the proportion of these constituents up to the standard, allowance being made for the small amount already present derived from the soil.

The results of this series were in strict conformity with those of the preceding series. The evidence was slight for the presence in the soil solutions, even in those from the dunged plot, of other substances favourable to growth.

We may now consider how far these results bear on the theory that crops leave behind in the soil specific toxins which depress the growth of succeeding crops of the same kind. In Series I. wheat and barley yielded almost exactly the same weight of plant whether they grew in solutions from the wheat or barley soils. (Table I.) As a rule, the wheat plants were a little heavier when grown in the solutions from the barley soils than when grown in solutions from the corresponding wheat soils (3 compares with 1,0, 11 with 2A, 7 with 4A, 2 with 7/2), but the barley plants were similarly heavier in the solutions from the barley soils. The ratio of root to shoot is very close in the two sets. Again, wheat and barley grown in the same solution yield weights agreeing within the range of error of such experiments. These facts alone would dismiss the hypothesis that the wheat soils contain any soluble toxin injurious to wheat but not to barley, and *vice versa*, notwithstanding the sixty years' repeated growth of these crops in the same soils. In Series II. the demonstration was pushed a stage further by including in the comparison an artificial culture solution made from pure salts, and containing phosphoric acid and potash in the same proportions as the solutions from the completely

manured plots. Another set of the soil solutions was boiled before use, since boiling had been reputed to destroy the toxin and would, at any rate, kill off any bacteria that might be factors in the result. Lastly, in another set the solutions were evaporated, the residue ignited and dissolved afresh in a minimum quantity of hydrochloric acid, then diluted to the original volume.

In this series boiling was without effect, whether the solutions contained added nutrients or not; the residue left on evaporation, after ignition and revolution, gave generally lower results, in some cases to a marked degree. The soil solutions from completely manured plots gave higher yields than the artificial solutions of corresponding strength.

In order to ascertain whether the results were limited in any way by the nature of the plant (it might be objected as regards Series I. that barley and wheat are so closely akin as to excrete the same toxin), the experiments in Series II. were repeated with sunflowers, white lupins, and buckwheat. These plants are far from being so suitable for experiment as barley, and the results were somewhat erratic, but they in no way indicated the presence of a toxin in the soil solution which depresses the growth of barley, but *ex hypothesi* is without effect on plants of another order. Finally, in Series III., both barley and peas grew freely in the soil solutions from the completely manured plots and in the solutions from the incompletely manured plots after repair of the deficiency by adding salts as in the artificial solutions made up with pure salts. Indeed, the superiority, though hardly large enough to be significant, lay with the plants grown in the soil solutions. Thus the experiments yielded no evidence of the existence in soils on which a particular plant had been growing for sixty years and upwards of a soluble "toxin" having a depressing effect upon the growth of that plant.

The next stage in the investigation was to ascertain how far the concentration of the nutrient solution had an effect upon the growth of the plant. A standard solution was made up and diluted to  $\frac{1}{5}$ ,  $\frac{1}{10}$ , and  $\frac{1}{20}$  respectively, barley being again the plant selected for growth. From the very outset growth proceeded in the order of the concentration of the solutions, but the results might be open to the objection that the solutions became exhausted and the final state of the plants had been limited by the amount of food at the plants' disposal.

Another series was then arranged on the same lines, except that the solutions were renewed weekly, so as to secure that the plant always had some nutriment at its disposal.

The photographs (*Pl. I., Figs. 1 & 2*) representing early and late stages in the development of these plants, sufficiently indicate that the rate of growth depended directly upon the concentrations of the solutions and not merely upon the amount of food available for the plant.

Two further series of trials were then carried out, in which the plants were grown in coarse sand contained in vertical glass cylinders, through which the nutritive solution of varying concentrations was allowed to percolate slowly, so that the roots were always in contact with a constantly renewed solution of the concentration indicated. Again, the photographs, *Pl. II.*, may be taken as sufficient indication of the character of the results obtained, which confirmed the conclusion that within certain wide limits the concentration of the nutritive solution is a factor in the rate of plant growth, irrespective of the total amount of plant food available.

The main purpose of the investigation had now indeed been attained. Actual soil solutions made from known soils had been found to vary in composition in



accordance with the composition of the soils. Further, the rate of growth either in these soil solutions or in others artificially made up of varying concentration had been found to depend both on the composition and the concentration, and no evidence had come to light of the existence in soils in which barley or wheat had been grown for many years in succession of the presence of toxic substances injurious to these plants. The last experiments, however, had raised an interesting side issue. One might conceive that even if the normal soil solution be of constant composition the rate at which it will be renewed after depletion by the growing plant will vary with the actual amount of solid compounds of phosphoric acid and potash in the soil. The root hairs of the plant will exhaust the solution with which they are in contact ; then since the water in the soil exists in a state of thin films coating the soil particles so much time might elapse during the travel of the nutrients from the points of solution along the extensive film to the root hairs that in a soil deficient in phosphoric acid and potash the plant might always be less well nourished than in a richer soil in which the length of travel of the nutrients was smaller. To test this point, the nutrient solutions of varied concentration employed in the last series of experiments in bottles were also diffused as a thin film over a mass of sand, until the sand was sensibly damp, but no liquid could be squeezed out of it. The jars of sand contained exactly the same bulk of solution as the bottles ; they were weighed regularly and pure water added as required. The photograph, *Pl. III.* (exactly comparable with *Pl. I.*), shows the results obtained, which were unexpected, in that all the cultures in sand were much better than the cultures in solutions of the same concentration and amount in bottles (see Table VI.), though they showed the same variation of growth with

concentration. Exactly the same results were obtained when the experiment was repeated, but the nutrients were placed in narrow porous pots sunk in the sand, in order to ensure that the nutrients must diffuse before they could reach the roots.

There was thus no depression of growth due to slowness of diffusion of the nutrients along the water film on sand particles, but it might be supposed that such lag would become operative in the extended film that must exist on the far finer particles found in an ordinary soil. Accordingly a large quantity of sandy soil was graded into coarse sand as before, fine sand consisting of particles between 0.2 and 0.04 m/m. in diameter, and silt between 0.04 and 0.01 m/m. Pure kaolin was taken to represent a clay material largely constituted of still finer particles. The same solution was diffused over all the materials. The experiment was twice repeated, and the growth in all the solid media was superior to that in the same volume of solution in a bottle, so that the possibility of a retardation of growth due to slowness of diffusion may be dismissed. The photograph, however (*Pl. IV.*), shows that the growth in the sand was the best, next that in the kaolin, while those in the fine sand and silt fell much behind.

Why should the growth in the sand cultures be so much better than in the equivalent solutions contained in bottles? We were led to suspect that differences in the aeration of the roots might be the disturbing factor. The sand when properly wetted remains in a very open state, with large air spaces between the aggregates, and the roots could be observed traversing the whole medium freely. The kaolin preserved a very similar structure, whereas the fine sand and silt quickly settled down to a close mass. The appearance of the roots after they had been

washed out of the sand, etc. (see photograph *Pl. V.*), showed that they had been able to develop freely in the coarse sand and kaolin but had been greatly restricted in the fine sand and silt. Comparative water cultures were then arranged, in which one series were not aerated at all, whereas in the other bottles a continuous current of air was bubbled through the solutions. The experiment was repeated with barley and lupins, and the results obtained are sufficiently seen from the photograph, *Pl. VI.*, of a typical pair of aerated and non-aerated cultures.

These results are convincing as to the enormous gain to the plant from continuous aeration of the root, and to this factor alone may be set down the superiority of the cultures in solid media over the ordinary water cultures in which the aeration is not continuous.

Though several minor points remained for consideration they need not be here discussed, as they did not in any way modify the main results already set out.

The conclusions can only be regarded as entirely adverse to the theory of Whitney and Cameron. That begins by postulating a soil solution of constant composition in saturated equilibrium with the phosphates and potash compounds which, though varying in amount, should be practically identical in all soils. The solutions from the Rothamsted soils were, however, found to vary in composition in accord with their past manurial history. Thus we must conclude that the compounds of phosphoric acid and potash in the soil are by no means so simple and definite as they had been supposed, but vary within wide limits in their solubility according to their origin and the nature of the general mass of soil particles. Furthermore, the growth of the plant varied directly, though not proportionally, with the concentration (within wide limits)

of the solution with which its roots were in contact, and the growth in the soil solutions corresponded to the composition of the solutions, which in its turn agreed with the composition of the soils. That concentration of the nutrient solution, independent of the total amount of plant food available, is a factor in plant growth is a new point in plant physiology which had not previously been expected. Finally, no evidence could be found for the presence in the soil of specific toxic substances excreted by the plant and injurious to the repeated growth of the same plant, even in the case of soils which had grown the same plant for fifty or more years in succession.

From the point of view of agricultural chemistry, the net result of these investigations is to restore our earlier view of the direct nutrition of the plant by fertilisers and fertilising substances in the soil. The composition of the soil solution which determines the growth of the plant is dependent on the amount and on the mode of combination of the nitrogen, phosphoric acid, and potash in the soil, both of which are affected by the fertiliser supply, though in what manner and to what degree is not yet exactly determinable.

TABLE I.

YIELD OF WHEAT AND BARLEY, ROTHAMSTED, 1902-11.

| Character of Manuring.  | Wheat—Broadbalk. |                     |                |                          | Barley—Hoos. |                    |                |                          |
|---|------------------|---------------------|----------------|--------------------------|--------------|--------------------|----------------|--------------------------|
|   | Plot.            | Yield per acre.     |                |                          | Plot.        | Yield per acre.    |                |                          |
|   |                  | Grain.<br>Bush els. | Straw.<br>cwt. | Total<br>Produce.<br>lb. |              | Grain.<br>Bushels. | Straw.<br>cwt. | Total<br>Produce.<br>lb. |
| Unmanured<br>continuously   | 3                | 10·9                | 9·6            | 1801                     | 1,0          | 9·3                | 6·2            | 1276                     |
| N only, no P <sub>2</sub> O <sub>5</sub> .<br>K <sub>2</sub> O ... .. | 10               | 18·4                | 15·0           | 3256                     | —            | —                  | —              | —                        |
| N + P <sub>2</sub> O <sub>5</sub> ... ..                              | 11               | 19·2                | 21·8           | 3778                     | 2A           | 29·7               | 19·3           | 3972                     |
| N + K <sub>2</sub> O ... ..   | —                | —                   | —              | —                        | 3A           | 20·3               | 15·6           | 2985                     |
| Complete artificial<br>fertiliser ...                                 | 7                | 31·0                | 35·5           | 6015                     | 4A           | 38·4               | 25·3           | 5087                     |
| Dung every year..   | 2                | 35·1                | 40·8           | 6925                     | 7/2          | 44·3               | 31·6           | 6184                     |

TABLE II.

GROWTH OF WHEAT AND BARLEY IN SOLUTIONS OF  
ROTHAMSTED SOILS. SERIES I., 1911.  
MEAN DRY WEIGHT IN GRAMS.

| Soil.            | Wheat. |       |        |                         | Barley. |       |        |                         |
|------------------|--------|-------|--------|-------------------------|---------|-------|--------|-------------------------|
|                  | Shoot. | Root. | Total. | Ratio.<br>Shoot<br>Root | Shoot.  | Root. | Total. | Ratio.<br>Shoot<br>Root |
| Wheat, Plot 3    | 0·170  | 0·135 | 0·305  | 1·26                    | 0·212   | 0·105 | 0·317  | 2·02                    |
| „ „ 10           | 0·157  | 0·127 | 0·284  | 1·24                    | 0·171   | 0·101 | 0·272  | 1·69                    |
| „ „ 11           | 0·598  | 0·260 | 0·858  | 2·30                    | 0·660   | 0·175 | 0·835  | 3·77                    |
| „ „ 7            | 0·923  | 0·448 | 1·371  | 2·06                    | 1·302   | 0·442 | 1·744  | 2·95                    |
| „ „ 2            | 1·137  | 0·425 | 1·562  | 2·68                    | 1·249   | 0·377 | 1·626  | 3·31                    |
| Barley, Plot 1,0 | 0·240  | 0·169 | 0·409  | 1·42                    | 0·264   | 0·138 | 0·402  | 1·91                    |
| „ „ 2A           | 0·476  | 0·199 | 0·675  | 2·39                    | 0·611   | 0·137 | 0·747  | 4·46                    |
| „ „ 3A           | 0·208  | 0·201 | 0·409  | 1·03                    | 0·275   | 0·119 | 0·394  | 2·31                    |
| „ „ 4A           | 1·203  | 0·627 | 1·830  | 1·92                    | 1·600   | 0·477 | 2·077  | 3·35                    |
| „ „ 7/2          | 1·195  | 0·511 | 1·706  | 2·34                    | 1·364   | 0·486 | 1·850  | 2·81                    |

TABLE III.  
COMPOSITION OF SOIL SOLUTIONS AND SOILS.—  
ROTHAMSTED.

| Field and Plot.  | Phosphoric Acid.                 |         |                     |                                    | Potash.        |         |                     |                                    |
|------------------|----------------------------------|---------|---------------------|------------------------------------|----------------|---------|---------------------|------------------------------------|
|                  | Soil solution parts per million. | Soil.   |                     | Manure annual supply lb. per acre. | Soil solution. | Soil.   |                     | Manure annual supply lb. per acre. |
|                  |                                  | Total % | Citric Acid soluble |                                    |                | Total % | Citric Acid soluble |                                    |
| Wheat, Plot 3    | 0.656                            | 0.114   | 0.0078              | 0                                  | 3.64           | 0.220   | 0.0032              | 0                                  |
| „ „ 10           | 0.881                            | 0.123   | 0.0074              | 0                                  | 3.55           | 0.240   | 0.0032              | 0                                  |
| „ „ 11           | 3.839                            | 0.197   | 0.0405              | 60                                 | 3.88           | 0.197   | 0.0032              | 0                                  |
| „ „ 7            | 3.938                            | 0.195   | 0.0547              | 60                                 | 26.22          | 0.262   | 0.0232              | 100                                |
| „ „ 2            | 4.838                            | 0.215   | 0.0560              | 46                                 | 29.85          | 0.285   | 0.0384              | 60                                 |
| Barley, Plot 1,0 | 0.525                            | 0.099   | 0.0055              | 0                                  | 3.40           | 0.183   | 0.0036              | 0                                  |
| „ „ 2A           | 3.900                            | 0.173   | 0.0425              | 60                                 | 3.88           | 0.248   | 0.0023              | 0                                  |
| „ „ 3A           | 0.808                            | 0.102   | 0.0081              | 0                                  | 30.33          | 0.257   | 0.0407              | 100                                |
| „ „ 4A           | 4.025                            | 0.182   | 0.0500              | 60                                 | 24.03          | 0.326   | 0.0298              | 100                                |
| „ „ 7/2          | 4.463                            | 0.176   | 0.0447              | 46                                 | 26.45          | 0.167   | 0.0321              | 60                                 |

TABLE IV.

GROWTH OF BARLEY IN SOLUTIONS FROM HOOS  
BARLEY PLOTS. SERIES II, 1912.

| Set. | Nature of Solution.   | Shoot. | Root. | Total. | Ratio<br>Shoot.<br>Root. |
|------|---|--------|-------|--------|--------------------------|
| 1    | Artificial culture solution, low concentration .....                | 0'514  | 0'249 | 0'763  | 2'06                     |
| 4    | Artificial culture, high concentration...                           | 0'652  | 0'291 | 0'943  | 2'24                     |
| 2    | Soil solution, Plot 1,0, unmanured. . .                             | 0'116  | 0'100 | 0'216  | 1'16                     |
| 3    | Soil solution, Plot 1,0, + added salts,<br>low concentration .....  | 0'865  | 0'349 | 1'214  | 2'48                     |
| 5    | Soil solution, Plot 1,0, + added salts,<br>high concentration ..... | 0'677  | 0'297 | 0'974  | 2'28                     |
| 2    | Soil solution, Plot 2A, lacking potash                              | 0'353  | 0'133 | 0'486  | 2'65                     |
| 3    | Soil solution, Plot 2A, + added salts,<br>low concentration.....    | 0'795  | 0'359 | 1'154  | 2'22                     |
| 5    | Soil solution, Plot 2A, + added salts,<br>high concentration .....  | 0'619  | 0'306 | 0'925  | 2'02                     |
|      | Soil solution, Plot 4A, complete fertiliser .....                   | 0'685  | 0'278 | 0'963  | 2'47                     |
| 5    | Soil solution, Plot 4A, + added salts,<br>H.C. ....                 | 0'926  | 0'423 | 1'349  | 2'19                     |
| 2    | Soil solution, Plot 7/2, dunged.....                                | 1'069  | 0'396 | 1'465  | 2'70                     |
| 5    | Soil solution, Plot 7/2, dunged, + added<br>salts, H.C.....         | 0'814  | 0'472 | 1'286  | 1'73                     |

## COMPOSITION OF SOLUTIONS.

|   |                                       | Nutrients, parts per million. |                   |                               |                  |                     |
|---|---------------------------------------|-------------------------------|-------------------|-------------------------------|------------------|---------------------|
|   |                                       | From Soil.                    |                   | From added Salts.             |                  |                     |
|   |                                       | P <sub>2</sub> O <sub>6</sub> | K <sub>2</sub> O  | P <sub>2</sub> O <sub>6</sub> | K <sub>2</sub> O |                     |
| 1 | Artificial culture solution           | Nil.                          | Nil.              | 4'7                           | 26'7             | Low concentration.  |
| 2 | Soil solution .....                   | 0'6<br>to<br>4'7              | 3'4<br>to<br>26'7 | Nil.                          | Nil.             | Varies with plot.   |
| 3 | Soil solution, with added salts ..... |                               |                   | 4'5                           | 26'5             |                     |
| 4 | Artificial culture solution           | Nil.                          | Nil.              | 303'5                         | 312'4            | High concentration. |
| 5 | Soil solution, with added salts ..... | as(2)                         | as(2)             | 303'5                         | 312'4            | High concentration. |



TABLE V.

BARLEY AND PEAS IN SOLUTIONS FROM HOOS FIELD  
BARLEY SOILS. SERIES III., 1912.

|  | Artificial<br>culture<br>solution. | Plot 1,0,<br>unmanured. | Plot 2A,<br>lacking<br>potash. | Plot 3A,<br>lacking<br>phosphoric<br>acid. | Plot 4A,<br>complete<br>manure. | Plot 7/2,<br>dunged |
|--|------------------------------------|-------------------------|--------------------------------|--|---------------------------------|---------------------|
|  | Parts per million.                 |                         |                                |  |                                 |                     |
| Phosphoric acid in original<br>solution ... ..                           | 4.5                                | 0.525                   | 3.90                           | 0.808                                      | 4.025                           | 4.463               |
| Potash in original solution.   | 26.5                               | 3.40                    | 3.88                           | 30.33                                      | 24.03                           | 26.45               |
|  | Dry weight of Plant.               |                         |                                |  |                                 |                     |
| Nature of solution.  |                                    |                         |                                |  |                                 |                     |
| Barley—  |                                    |                         |                                |  |                                 |                     |
| Solution only ... ..   | 0.319                              | 0.149                   | 0.213                          | 0.167                                      | 0.303                           | 0.403               |
| „ + N ... ..   | 0.292                              | 0.149                   | 0.226                          | 0.184                                      | 0.346                           | 0.404               |
| „ + N, P <sub>2</sub> O <sub>5</sub> and<br>K <sub>2</sub> O to standard | —                                  | 0.420                   | 0.395                          | 0.323                                      | —                               | —                   |
| „ + N + standard<br>P <sub>2</sub> O <sub>5</sub> and K <sub>2</sub> O   | 0.366                              | 0.435                   | 0.400                          | 0.364                                      | 0.358                           | 0.438               |
| Peas—  |                                    |                         |                                |  |                                 |                     |
| Solution only ... ..   | 1.731                              | 1.082                   | 1.184                          | 1.192                                      | 1.449                           | 1.630               |
| „ + N ... ..   | 1.524                              | 1.157                   | 1.404                          | 1.335                                      | 1.720                           | 1.743               |
| „ + N, P <sub>2</sub> O <sub>5</sub> and<br>K <sub>2</sub> O to standard | —                                  | 2.299                   | 1.800                          | 1.961                                      | —                               | —                   |
| „ + N + standard<br>P <sub>2</sub> O <sub>5</sub> and K <sub>2</sub> O   | 1.769                              | 2.553                   | 2.493                          | 2.136                                      | 2.157                           | 2.182               |

TABLE VI.

COMPARATIVE GROWTH OF BARLEY IN SAND  
AND WATER CULTURES OF EQUAL  
CONCENTRATION.

| Concentration of Solution. | Dry weight of plant. |       |
|----------------------------|----------------------|-------|
|                            | Water.               | Sand. |
|                            | Gms.                 | Gms.  |
| 1                          | 1'655                | 7'050 |
| "                          | 2'075                | 4'200 |
| 1/5                        | 1'245                | 3'539 |
| "                          | 1'492                | 3'031 |
| 1/10                       | 1'030                | 3'171 |
| "                          | 0'943                | 2'882 |
| 1/20                       | 0'681                | 1'556 |
| "                          | 0'537                | 1'437 |



EXPLANATION OF PLATES.

*Plate I.* Growth of barley in solutions of varying concentration but similar composition. *Fig. 1* after 8 weeks. *Fig. 2* after 4 weeks.

*Plate II.* Growth of barley in similar solutions diffused over sand particles. *Fig. 1* after 8 weeks. *Fig. 2* after 4 weeks.

*Plate III.* Growth of barley in sand through which solutions of varying concentration were percolating.

*Plate IV.* Growth of barley in coarse sand, fine sand, silt, kaolin, and water, the solution being of the same concentration in all.

*Plate V.* Lupins grown under similar conditions to the barley in *Plate IV.*, the roots washed free of the medium.

*Plate VI.* Barley grown in nutrient solutions aerated once a day (left) and continuously aerated (right).



Fig. 1.

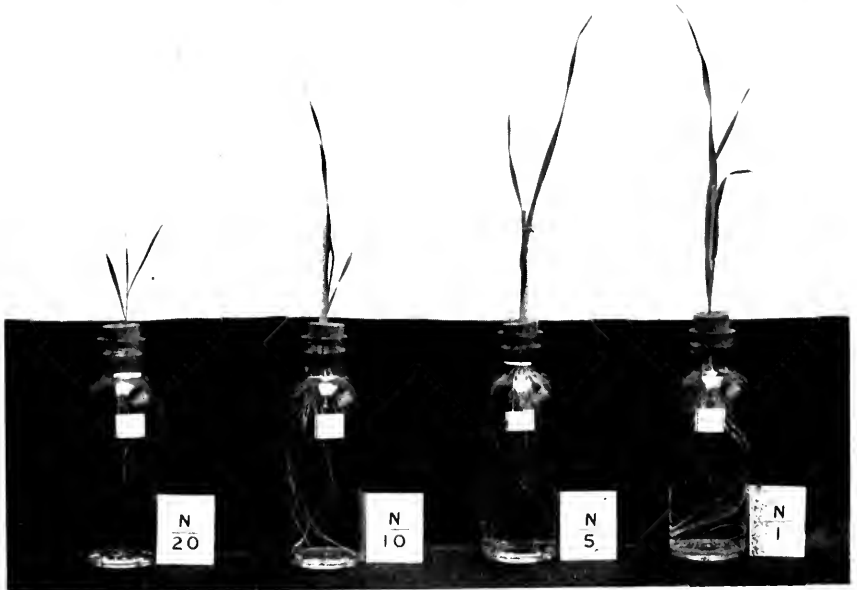

Fig. 2.



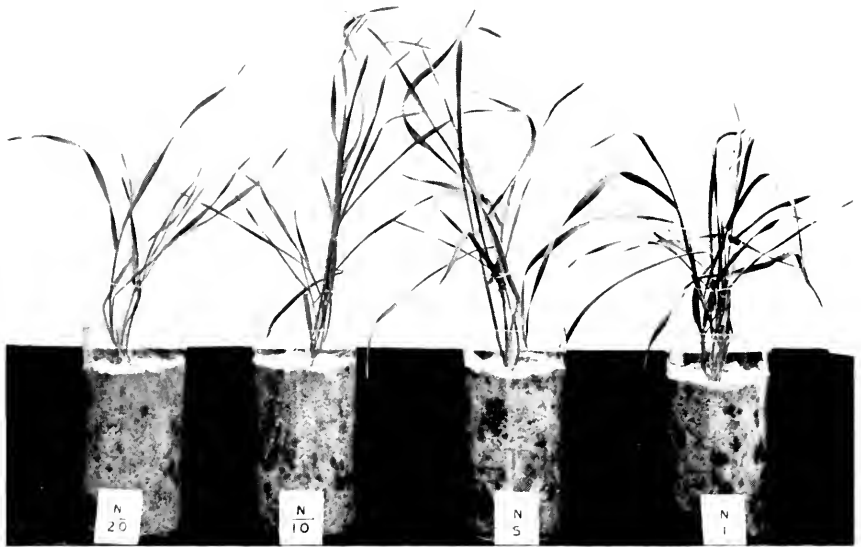

Fig. 1.

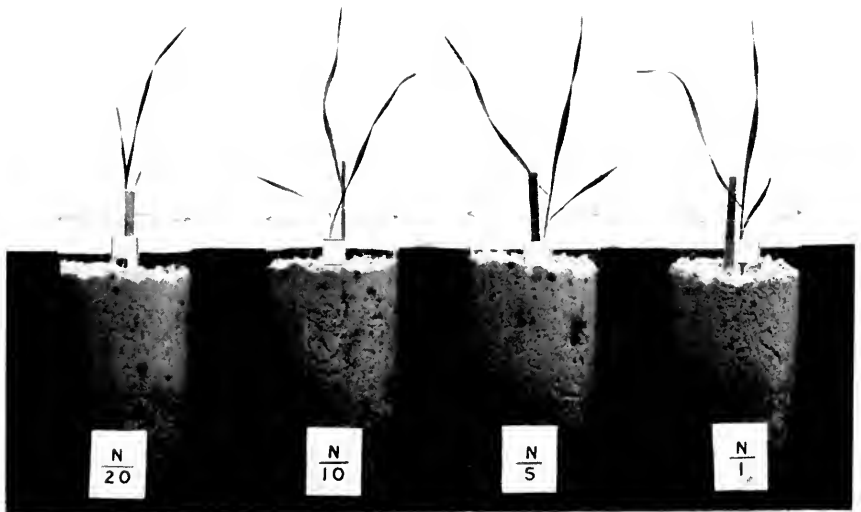
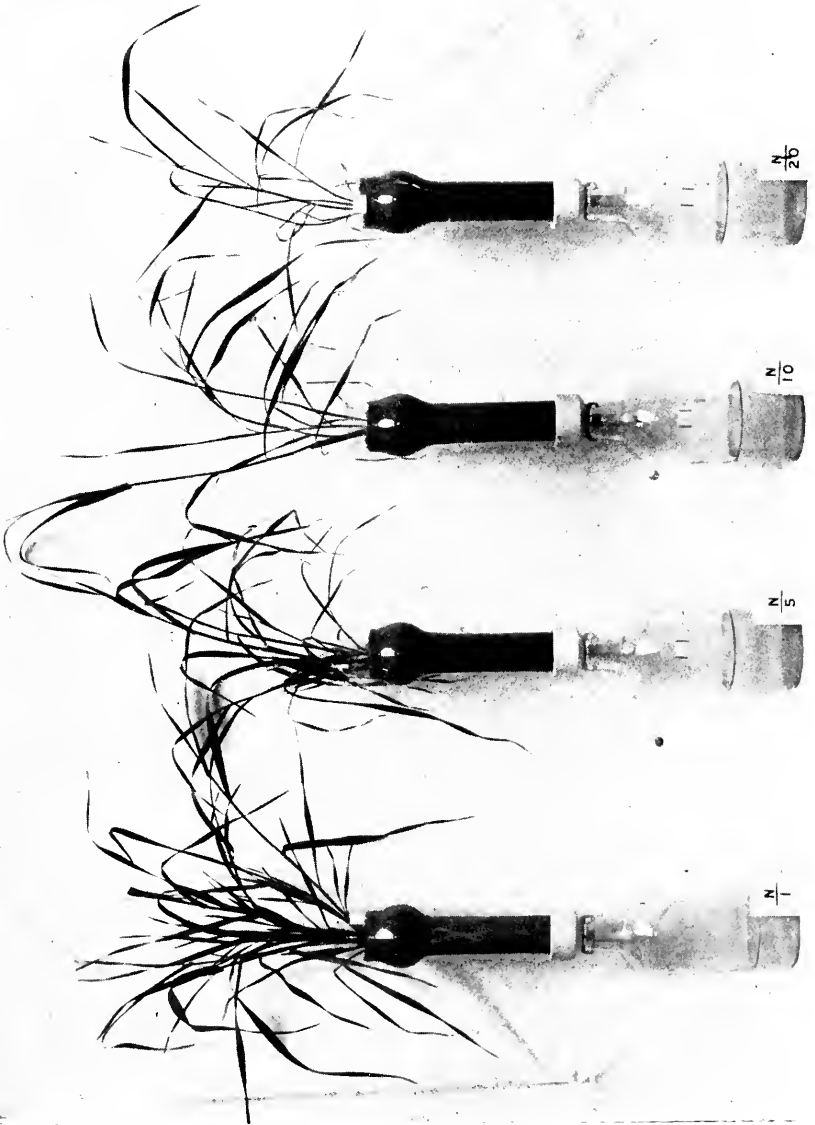

Fig. 2.









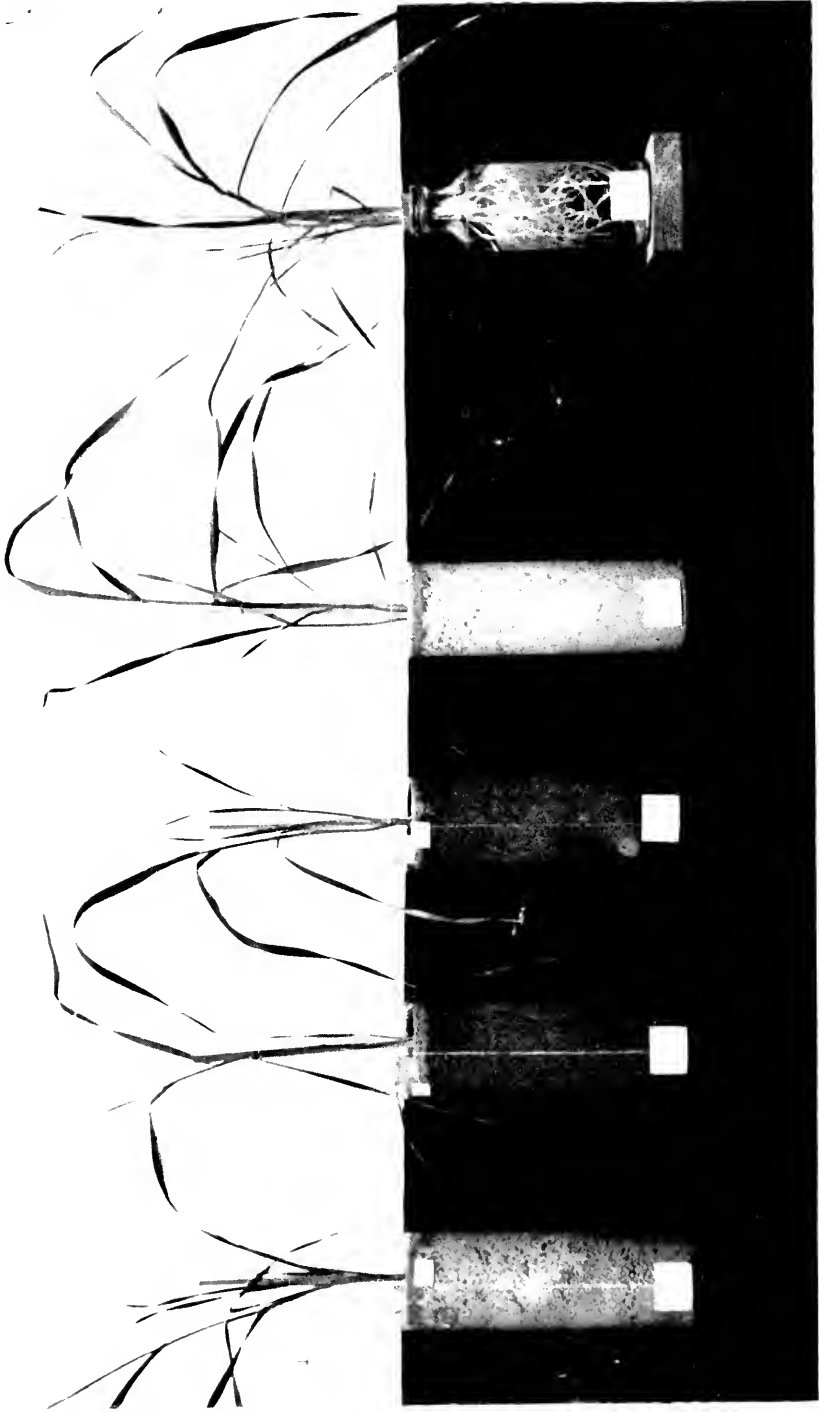





1. Coarse Sand.

2. Fine Sand.

3. Silt.

4. Kaolin.

5. Water.









## VII. Some notes on the measurement of air velocities, pressures and volumes.

By WILLIAM CRAMP, M.I.E.E., M.Sc.Tech.

*(Received and read January 13th, 1914.)*

### I. MEASUREMENT OF AIR VELOCITY.

The measurement of air velocity is usually carried out by means of an anemometer or a so-called "facing gauge" and manometer. The former is well known, and may give fairly accurate results if sufficient precautions are taken. Thus to obtain the air velocity at any point in an air duct many readings must be taken and the results averaged. To obtain the average velocity over a given section of a duct, many positions over the section must be selected and several readings taken at each, when a proper average may be obtained. To attempt such a series, however, is often impracticable, for the following reasons:—

- (1) The anemometer is not a small instrument, and its very presence in the duct is often sufficient to falsify the normal condition in the duct.
- (2) The reading is often required at a position within a pipe where the anemometer cannot be seen at all, much less handled. The absurdity of relying on it in such a case is obvious when it is remembered that it must be used in conjunction with a stop watch, and that the plane of its wheel must be normal to the current measured.

*May 26th, 1914.*

- (3) Acceleration and retardation must exist in connection with the wheel, so that the operator never knows in timing it when it attained its final in the duct.
- (4) Friction must make an enormous difference to its readings, and it is impossible to eliminate this or to make it follow any definite law.

Thus in nine cases out of ten occurring in ordinary practice the anemometer is unreliable. The sole instance in which it may be of use is that in which the Admiralty adopt it, viz., to measure the volume of air at the open end of a tube carrying air, by a series of velocity readings taken uniformly over the open end. Generally speaking, the author has found it entirely unsatisfactory, and he regards it more as an indicator than a scientific instrument.

The facing gauge consists of a tube with one end square with its axis placed or shaped so that this end faces the current to be measured, the other end being connected to a manometer. If the other end of the manometer be open to atmosphere, the pressure registered will be the sum of the static head above or below atmosphere at the gauge tip and the kinetic head due to the velocity at the same place. Thus the manometer reading is—

$$p = \left( h \pm \frac{v^2}{2g} \right) \frac{\rho}{\rho_1}$$

where  $h$  is the static head of air,  $v$  its velocity, and  $\rho$  and  $\rho_1$  the densities of air and the manometer fluid respectively. Since  $\rho$  and  $\rho_1$  are usually known with sufficient accuracy,  $v$  can be deduced if  $h$  is known, and the instrument being small and accurate it can be used where anemometers are impossible. Now careful tests show that  $p$  can be obtained accurately if the facing tube be (*a*) small in diameter, (*b*)

shaped so as to disturb the stream lines as little as possible. These are conditions easy of fulfilment.

It very often happens, however, that  $h$  is of the same order as  $v^2/2g$ , whence great inaccuracies result in deducing  $v$  unless  $h$  can be measured very accurately, or eliminated by using the facing gauge at practically atmospheric pressure. The latter, however, is often impossible, and it is thus necessary to measure  $h$  accurately. So the accurate measurement of velocity is seen to depend upon the accurate measurement of static head or pressure.

## II. MEASUREMENT OF AIR PRESSURE ( $h$ ).

Measurement of pressure is usually attempted by providing an orifice whose plane is as nearly as possible parallel to the stream lines at that point, this orifice being in communication by means of a small tube with a bourdon gauge, manometer or other instrument of a similar nature. Since the insertion of such a tube in the stream itself tends to disturb the stream lines, it is usual to make both tube and orifice as small as possible. So long as the effect of any disturbance due to the presence of the tube is small compared with the pressure measured, such a method is satisfactory and practical. But there are very many circuits in which this is not the case, particularly when the velocity of the air stream far exceeds the limit of steady flow. Then is observed that phenomenon known as "induction effect," which is in reality a lowering of the pressure to be recorded by a counter pressure due to the rush of the fluid past the orifice. This effect may be so large as to mask altogether, or even to reverse the true pressure reading, and no change in the form or sensitiveness of the gauge will help matters. Thus, with air circuits for ventilation and dust-collecting purposes, where the total pressure above or below atmosphere does

not exceed about 10 in. of water while velocities of 40 ft. to 70 ft. per second are common, a good deal of trouble may be experienced, and the characteristics of ordinary centrifugal and propeller fans are often falsified by the error referred to.

Now Heenan and Gilbert, in 1895,\* published some careful tests on various orifices or tips with the object of discovering one that would reduce these disturbing effects to a minimum. The tips which they used are illustrated

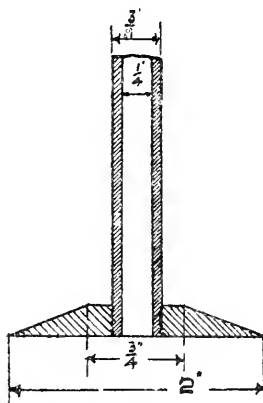

Fig. 1.

in their paper, and the method of test consisted in attaching the tip to a long arm, which was rotated in a circular tank 7 ft. in diameter, provided with baffles to reduce the movement of air in the tank. Free communication was established by means of a special tube between the tip under test and a recording water gauge. In this way, if there were no induction the reading of the gauge should correspond with the pressure due to the centrifugal force of the air in the rotating tube. From the speed the value of the latter could be exactly calculated, and thus the inductive effect was deduced. The best results were

\* *Proc. Inst. C.E.*, vol. cxxiii., pt. 1.

obtained with the tip shewn in *Fig. 1*, and so this was adopted throughout their subsequent work.

The gauge, however, which Messrs. Heenan and Gilbert used would only read to  $1/44$  of an inch of water, and further, by their very method of adopting baffles they reduced the movement of the air. This, while tending to increase the inductive action on the tip, would also tend to produce a condition of the air quite different from that existing in air having the same relative velocity with respect to a stationary gauge.

Some three years ago the author had occasion to test accurately a number of fans, and he very soon discovered that the tip recommended by Heenan and Gilbert gave results inconsistent with its supposed accuracy. He therefore determined to test it, if possible, by a method in which the conditions should be those existing in the experiments which he was about to carry out. To obtain such a method was, however, very difficult, as it involved separating the true pressure from the "induction effect" without being able to determine the actual value of the latter. Since the equation was:—

Measured pressure = true static head  $\pm$  induction effect.

The only possible method seemed to be that of measuring the pressure at a point where the true static head was known. Now the only value of the latter that could be properly known was zero; and an apparatus was therefore constructed in which a zero point could be found, and which was of such a size as to be a test under practical conditions.

*Apparatus.* This consisted of an ordinary six-bladed centrifugal fan having a wheel  $6\frac{1}{8}$  in. wide at the outer periphery, and 18 in. in diameter over the blades. The case was properly constructed with diffuser and volute, the latter having a mean outside diameter of 30 in. The eye was 10 in.

in diameter, and the outlet 9 in. in diameter. An air circuit was made up of an isosceles triangle of 9 in. tinned iron piping. At the junction of the two equal sides was placed the fan, drawing from one side and delivering into the other, the length of these sides being 29 ft. The length of the base of the triangle was 33 ft. 8 in., and this was joined to the sides by two bends (forming the angles of the base) each 10 ft. in diameter. It is evident that somewhere near the middle point of the base of such a circuit the true pressure must be atmospheric, and accordingly a slot,  $7/16$  in. wide and 2 ft. long, was provided at the middle of the base and fitted with a sliding cover so that various gauges could be inserted and moved for a distance of 1 ft. on either side of the central point. It was argued then that any gauge reading zero at one point, and with one velocity, should read zero at all velocities at that point if there were no induction.

This argument is not quite sound unless the whole air circuit be truly symmetrical, which in practice can never be the case. If, however, the circuit can be adjusted so that under any circumstances an increase of velocity tends to move the zero point towards the outlet of the fan, then induction and zero-movement are of the same sign with increasing velocity; and consequently that tip which with increasing velocity shows the smaller change of reading will be the least affected by induction.

It is easy by slides at the inlet and outlet of the fan to arrange the conditions under which the zero will move slightly as required above, and this was done for all the experiments.

*Instruments.* It will be clear that for such measurements manometers were required of a far more delicate nature than those used by Heenan and Gilbert. The apparatus selected was a Krell micromanometer having two

inclinations, viz.,  $1/20$  and  $1/4$ . These give corresponding multiplications. The fluid used was alcohol of specific gravity 0.8. The gauge can be read easily to  $\frac{1}{2}$  m/m., and this corresponds therefore to approximately  $1/40$  m/m. or  $1/1200$  inch. An interesting point is that with such readings no ordinary glass tube is sufficiently accurate, and the scale must be made to the instrument to counteract irregularities in the bore of the tube.

The following tips were selected for tests:—

- (1) A disc gauge exactly like that of Heenan and Gilbert.
- (2) A disc gauge with a tin disc  $2\frac{1}{8}$  in. diam.
- (3) A disc gauge „ „  $1\frac{5}{8}$  in. „
- (4) A Nipher collector. (*Fig. 2.*)
- (5) A Brabbée tube. (*Fig. 3.*)
- (6) A side tube  $1/16$  in. diameter, with orifice flush with the pipe wall.

The Nipher and Brabbée tubes were included because they are the latest instruments in use in Germany for the purpose. The side tube was used for two reasons: firstly, because being in the pipe wall it should be very free from induction, because the air velocity is so much lower there; secondly, because it was strongly recommended to the author by Mr. S. C. Davidson, of Belfast, who has done much good work in this direction.

The Nipher collector (*Fig. 2*) is a disc gauge made up of a number of discs of gauze held between two plates. The air passing into the central tube *a* (*Fig. 2*) must pass through the holes *h* in the outer disc and thence through the gauze. The Brabbée tube will be seen from *Fig. 3* to consist of a side gauge, combined with a facing gauge. Pressure readings are taken from the pipe *a*, which is in communication with the holes *h*. If the part of the tube containing the holes *h* is parallel with the air duct

and the end  $n$  faces the current, the stream lines passing the tiny holes  $h$  must be parallel with the tube, and little induction effect is to be anticipated.

As a general result it may be stated that the side gauge and the Brabbée tube read practically alike throughout, and their readings are therefore placed in one

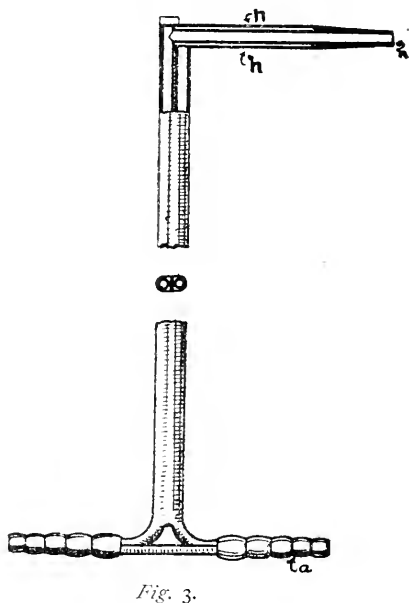
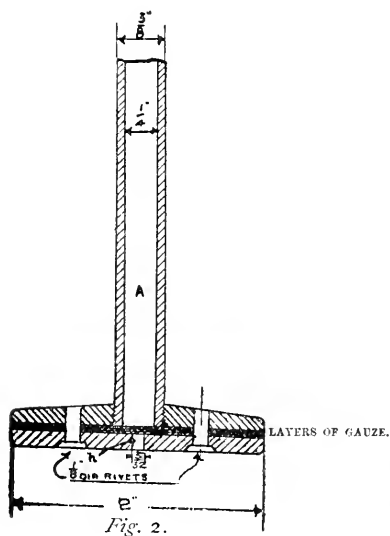

column. Again, Nos. 1 and 2 read practically alike throughout, and they are accordingly placed together. No. 3 was never as good as either 1 or 2, and its readings are therefore omitted. The Nipher collector was found to be so inaccurate that its use was abandoned. An example of the readings obtained with it is, however, given below. All the preliminary tests are omitted from the following tables, which simply give sample tests showing the order of the differences obtained. For each table the slides at the fan inlet and outlet were carefully



EXPERIMENTS WITH SIDE GAUGE TIPS.

*Apparent induction at a point at which the Brabbée gauge gave zero reading at 6.8 m/sec.*

| Velocity.<br>m/sec. | Brabbée Tube.<br>Reading m/m. | Disc Tip.<br>Reading m/m. | Nipher Collector.<br>Reading m/m. |
|---------------------|-------------------------------|---------------------------|-----------------------------------|
| 6.80                | - 0                           | - 0.150                   |                                   |
| 7.15                | - 0                           | - 0.150                   |                                   |
| 7.79                | - 0.025                       | - 0.200                   |                                   |
| 8.54                | - 0.050                       | - 0.250                   |                                   |
| 8.68                | - 0.050                       | - 0.250                   |                                   |
| 8.97                | - 0.050                       | - 0.250                   |                                   |
| 9.45                | - 0.075                       | - 0.275                   |                                   |
| Difference 2.65     | - 0.075                       | - 0.125                   |                                   |
| 10.00               | - 0                           | - 0.45                    | - 1.975                           |
| 11.10               | - 0.05                        | - 0.60                    | - 2.30                            |
| 11.50               | - 0.075                       | - 0.725                   | - 2.875                           |
| 12.16               | - 0.150                       | - 0.775                   | - 3.35                            |
| 12.98               | - 0.175                       | - 1.00                    | - 3.60                            |
| 13.45               | - 0.175                       | - 1.00                    | - 3.825                           |
| 14.0                | - 0.025                       | - 1.075                   | - 4.225                           |
| 14.48               | - 0.275                       | - 1.25                    | - 4.505                           |
| 15.02               | - 0.375                       | - 1.35                    | - 5.00                            |
| Difference 5.02     | - 0.375                       | - 0.90                    | - 4.025                           |

*Second set of experiments—Zero determined by disc gauge.  
Whirl prevented by wooden cross in the inlet.*

| Velocity.       | Disc Reading. | Brabbée Reading. | Velocity. | Disc Reading. | Brabbée Reading. |
|-----------------|---------------|------------------|-----------|---------------|------------------|
| 5.73            | - 0           | + 0.075          | 9.29      | 0             | + 0.375          |
| 6.00            | - 0           | + 0.050          | 9.73      | 0             | + 0.400          |
| 6.66            | - 0.025       | + 0.050          | 10.62     | - 0.025       | + 0.425          |
| 6.93            | - 0.075       | + 0.050          | 11.68     | - 0.050       | + 0.450          |
| 7.08            | - 0.075       | + 0.050          | 11.80     | - 0.075       | + 0.475          |
| 7.42            | - 0.075       | + 0.025          | 12.38     | - 0.075       | + 0.500          |
| 7.80            | - 0.075       | + 0.025          | 13.09     | - 0.125       | + 0.500          |
| Difference 2.07 | - 0.075       | + 0.05           | 3.80      | - 0.100       | + 0.135          |

+ readings above atmosphere, - below.

set, and velocity changes were then obtained by means of the shunt motor driving the fan, the speed being varied by means of a shunt resistance.

The velocity readings in these tables were obtained by a carefully-constructed facing gauge forming part of the Brabbée tube. The disturbance caused by this tube in the current of air is probably less than that due to any other form of tip, its tapered and thin shape allowing the air to flow smoothly past it with little eddying. A further advantage is that the actual velocity and pressure are measured at nearly the same point in the air stream.

#### CRITICISM OF RESULTS.

In the first series of figures the difference in reading between the Brabbée and the Disc tip is nearly 1mm. as a maximum, and this would mean an error in the velocity of nearly 30%, so that the question of the accuracy of the pressure gauge is of enormous importance. The readings generally showed so much more difference than I anticipated that I sought for a reason. I found that the air many feet before the eye of the fan showed a whirling motion due to change of direction on entering the eye. This is a curious fact which was hardly to be expected, and shews that air behaves much more like an elastic solid than might have been anticipated. The distance along the pipe from the eye at which this whirl had considerable effect was as much as 20 feet. I therefore inserted just before the eye of the fan a wooden cross about 4 inches wide, forming four guide blades to prevent rotation of the air. The results are shown in the second series, and clearly indicate that this whirl affected the Brabbée very little compared with the disc.

The total differences are shewn at the bottom of the columns. When these are worked out per metre change

in air velocity they shew the great superiority of the Brabbée tube over any other form of side gauge except that which is flush with the pipe wall. The disadvantages of the latter are very apparent. For, firstly, in a commercial pipe system it is utterly impracticable to bore holes at all sorts of places for pressure measurement, and to render pipes in such holes absolutely flush with the inner duct surface. Another disadvantage lies in the impossibility of getting a pressure measurement at the same point as the velocity measurement, which is sometimes of considerable importance.

The Brabbée tube combines the pressure and velocity tubes in a single portable and accurate apparatus, which can be inserted at any hand hole or other accessible place in the air circuit.

#### TESTS ON ACCURACY OF POSITION.

It will be realised that where tubes like the Brabbée, Nipher or Pneumometer (see *Fig. 5*) are used, the position of the tube with respect to the pipe conveying the air may make a considerable difference. I made a few tests on this matter with the disc gauge, the Brabbée tube, and the Nipher collector by placing each in turn in the air pipe at a particular place, and keeping the air conditions constant. In the first instance each tube was set as accurately in its proper position as careful measurements would allow, and having taken pressure readings by this means the tube was moved through various angles to ascertain the effect on the pressure measurement of errors in setting. The angles were not very carefully measured, because the result of even a small movement of one or two degrees was sufficient to show that the Brabbée tube was the only one which gave readings of even approximate consistency. I believe that in the setting of this tube (as far as pressure

is concerned), an angular error of even  $10^\circ$  is not of very great importance. Of course for velocity readings the end of the facing gauge must not be displaced by more than about one degree.

### III. MEASUREMENT OF AIR VOLUMES.

When the average air velocity over any given section of a pipe is known the volume of air passing that section per second can easily be determined by measuring the pipe. But the average velocity cannot easily be measured; for even where accuracy in velocity measurement can be obtained it is a long and trying process to take measurements all over the section in order to obtain the average. To avoid the necessity for this, it is very usual to measure the velocity at the centre of the pipe and to allow a coefficient of contraction thus:—

Area of pipe section  $\times$  velocity at centre  $\times c =$  volume of air per second where  $c =$  coefficient of contraction allowed.

The value of  $c$  seems to vary considerably with different authors, although a small change in its value is of enormous importance in measuring, for instance, the efficiency of a fan. The values adopted by different authorities seem to vary between 0.65 and 0.9. The latter, I believe, is adopted by Davidson, while the former is used by Innes.\*

In order to test the accuracy of such figures in pipe circuits, I took a series of tests in a pipe 9 in. in diameter by means of a Brabbée tube and micromanometer. For each set of tests about ten positions of the tube were tried, and velocities ranging from 6 to 9 metres per second were adopted.

The result is shown in *Fig. 4*, whilst Table I. gives the ratio average flux per unit area  $\div$  central flux per

\* "The Fan," first edition, p. 36.

TESTS ON RATE OF FLOW AT DIFFERENT PARTS OF PIPE SECTION.  
 DIAMETER OF PIPE AT THIS POINT =  $8\frac{7}{8}$ ".

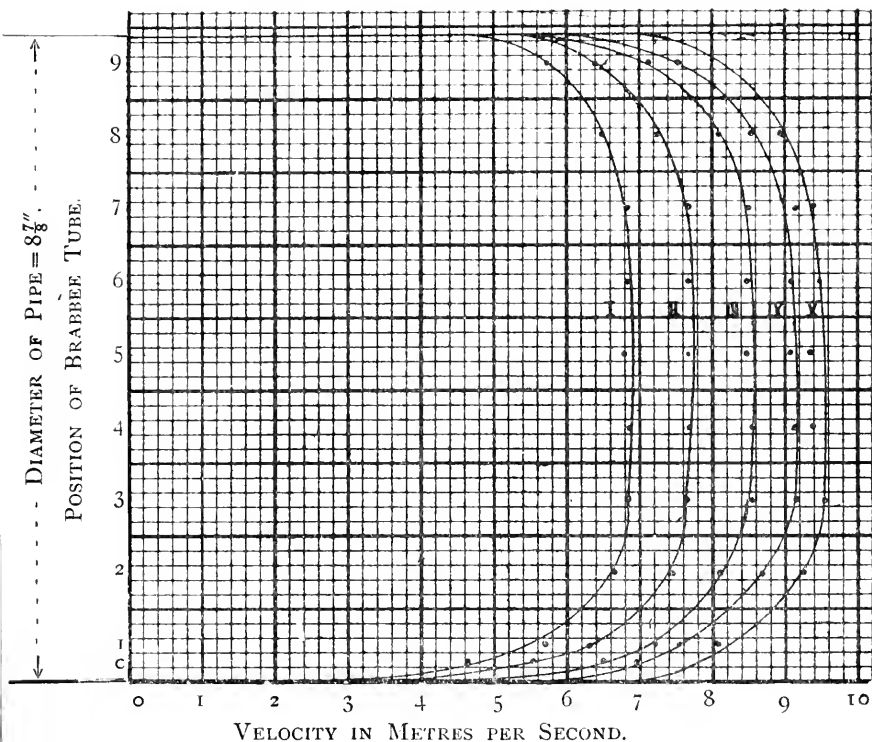

Fig. 4.

TABLE I.  
 COEFFICIENTS OF VELOCITY  
 ROUND TUBE  $8\frac{7}{8}$ " INSIDE DIAMETER.

| No. of Curve. | Mean Vel. m./sec. | Vel. at centre. | c.   |
|---------------|-------------------|-----------------|------|
| 1             | 6.18              | 6.89            | 0.8  |
| 2             | 6.98              | 7.72            | 0.9  |
| 3             | 7.75              | 8.53            | 0.9  |
| 4             | 8.28              | 9.16            | 0.9  |
| 5             | 8.69              | 9.42            | 0.88 |

unit area expressed above as  $c$ .\* It will be seen that the value of  $c$  varies slightly with change of velocity, but that the least value measured was little less than 0.9. With no slip at the boundaries, and assuming the value of  $\mu$  for air to be constant (as it is practically if the temperature be constant) the curves shown in *Fig. 4* should be parabolas, in which case the value of  $c$  would be 0.5. It is very clear that over an area of diameter = about half the pipe diameter, the velocity in all the tests is extremely uniform, and that the difference in the value of  $c$  is due more to the slope of the velocity curve from the edge of this diameter to the boundary than to any uniform change over the pipe area as a whole.

It is also worth while remarking that in the case of pipes carrying water the ratio  $c$  is of the order 0.85.

#### NOTE ON THE PNEUMOMETER.

Recently there has been introduced into Germany an instrument for velocity measurements known as the Pneumometer. It was originally invented by Dr. Krell, but a more convenient and more recent form is that invented by Dr. Prandtl (*Fig. 5*). The chief advantage of the latter lies in the fact that it may be used in a stream of air carrying considerable quantities of dust without becoming choked. The construction of the instrument is clear from the figure, and its action is as follows:—

When a circular lamina or disc  $e$  is immersed in a moving stream of fluid there is a small region on either side of the lamina where the fluid is at rest. If the plane of the lamina be at right angles to the stream, this region

\* NOTE.—If the velocity =  $(\varphi)r$  where  $r$  is the radius, the total flux =  $\int_0^R 2\pi r (\varphi)r dr$ ; in the table the integration has, of course, been carried out graphically as  $\varphi$  is very complex.

of "dead water" will be about the centre of the disc and on either side of it, and will be bounded by a surface of discontinuity.

On that side of the disc which faces the current, the pressure of the still fluid is given by the formula :

$$p = \frac{v^2}{2g} \rho.$$

and may be measured by a manometer in connection with the small tube *d*.

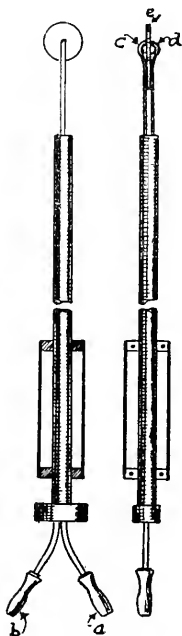

*Fig. 5.*

On the opposite side of the disc the pressure is lower than this in the ratio of 1 : 0.37. This has been tested at many velocities, and the ratio proved to be constant. Thus when the two tubes of the Pneumometer *c* and *d* are connected to the two ends of a manometer respectively, the pressure which the latter reads is :

$$p = 1.37 \frac{v^2 \rho}{2g \rho_1}$$

From which it is evidently easy to determine the velocity from the manometer reading.

The great advantage of the instrument is that static head is entirely eliminated, and the velocity is measured practically independently of any other condition. Thus, if the manometer be read in millimetres and the velocity in metres per sec. for  $0^\circ$  C. and 760 m/m Bar. the constant is:—

$$v = 3.33 \sqrt{p}$$

while for  $15^\circ$  C. it becomes:—

$$v = 3.41 \sqrt{p}$$

I have not been able to carry out careful tests with this instrument, but so far as I have been able to use it it agrees well with the Brabbée tube measurements, and therefore it must be fairly accurate.

Where clean gases are being dealt with, the form of Pneumometer invented by Krell is likely to be more accurate than that invented by Prandtl; for the former has no obstruction near the disc which can vary the pressure or cause eddy readings. Where, however, as is usually the case, there is dust in the stream, the small holes in the middle of the disc are liable to become choked, and its superior theoretical construction is then less useful than the more practical form of the other inventor. In the latter case it will be noted that even large pieces of material in the air would not influence the reading so long as the instrument is not damaged.

My acknowledgments are due to Messrs. Henry Simon, Ltd., who placed at my disposal the apparatus here mentioned, and to Mr. C. P. Kinnimonth, B.Sc.Tech., my assistant, who took many of the readings and helped me in every possible way.



## VIII. Faunal Survey of Rostherne Mere.

### I. Introduction and Methods.

By W. M. TATTERSALL, D.Sc.

AND

T. A. COWARD, F.Z.S., F.E.S.

*(Read March 24th, 1914. Received for publication March 31st, 1914.)*

During the last twenty years a considerable amount of attention has been paid by biologists on the Continent and in America to the study of the fauna of fresh-water lakes and rivers, more especially to the plankton, its constituents and periodicity. It is only necessary here to refer to the classical works of Forel on Lake Geneva, of Wesenburg-Lund on the lakes of Denmark and of Kofoid on the Illinois River in America, to indicate the thoroughness with which the study of Limnology has been prosecuted in these countries.

Owing mainly to the comparative inaccessibility of the British lakes and to the consequent difficulty of collecting samples regularly, the fauna and flora of our lakes have not received the attention they deserve. We owe to Messrs. W. and G. S. West a large series of observations on the phytoplankton of the British lakes, mainly from the lakes of Scotland and the Lake District of England. The late Sir John Murray, some fifteen years ago, instituted a bathymetric survey of the Scottish lakes and paid considerable attention to the fauna and flora, while Dakin and Latarche have recently published an account of the plankton of Lough Neagh, in Ireland, with

*May 30th, 1914.*

special reference to its periodicity and to the seasonal changes in the organisms constituting it.

No complete account of the fauna and flora of any of the English lakes has, however, yet been published, so far as we are aware. The proximity of Rostherne Mere to Manchester seemed to us to present a favourable opportunity for undertaking work of this kind, since it was possible to arrange for the collection of samples with some attempt at regularity. This mere, one of the largest and most important of the characteristic sheets of water which occur throughout the Cheshire plain, presents two features which render the elucidation of its biology of added interest, (1) the mode of its formation and (2) the geological strata upon which it lies. Rostherne Mere appears to be what has been described as a dissolution basin, that is, a depression on the surface of the earth caused by the gradual removal of underlying soluble rock as the result of the chemical and mechanical action of underground water. In this case, the bed rocks are themselves of a more or less impermeable character, but are underlaid at a greater or lesser depth by soluble rock salt. The gradual removal of this salt by underground water has resulted in subsidence of the surface and the consequent formation of a lake basin. The majority of the lakes of Scotland, the English Lake District and Wales are glacial basins, depressions on the earth's surface scooped out by the action of moving glaciers. Lough Neagh, on the other hand, is a tectonic basin, that is, a basin formed by deformation of the earth's crust by the subsidence or faulting of rock material deposited as the result of volcanic action. Rostherne Mere has thus been formed in quite a different way from any of the other British lakes whose biology has been investigated. The majority of the English, Welsh and Scottish lakes lie on the Pre-Cambrian or

Early Palæozoic rocks, while Lough Neagh is underlaid by Tertiary rocks, basalt of the Miocene period. The bed rocks of Rostherne Mere belong to the Triassic series of the Mesozoic or Secondary period. Here again, therefore, Rostherne presents an interesting comparison with the other lakes. We cannot yet say whether the mode of formation and the character of the underlying rocks have any direct relation to the fauna and flora; but the differences in these two features did seem to us to present points of interest, attention to which might yield important results in instituting a comparison with the fauna and flora of the other lakes of Britain. We may, perhaps, here point out that the character of the underlying rocks of the drainage area of a lake does seem to have a direct bearing on the nature of its plankton. Messrs. W. and G. S. West have pointed out that, in lakes situated on or draining the Pre-Cambrian and Early Palæozoic rocks, Desmids are the dominating constituent of the plankton and that the rich Desmid areas correspond geographically with the distribution of lakes on these primary rocks.

Our investigations were started with the sole object of studying the plankton, but we have been led to extend our observations to the whole of the fauna and flora in the hope of arriving at a knowledge of the interdependence and economy of the various living organisms which occur within a specified and naturally restricted area and of the correlation between the planktonic and benthonic forms. Completed in this way, our results will we hope form a basis for comparison with the fauna and flora of other British lakes. Mr. R. S. Adamson has kindly undertaken an ecological investigation of the flora of the mere and its surroundings, and we hope to present to the Society from time to time a series of reports by specialists on the various groups of the fauna. Finally,

we shall attempt a summary of the results obtained. In the present communication we propose to describe the geological and topographical characters of the mere, to give some account of the chemical composition of the water, and of our methods of working. This is followed by an account of the vertebrates observed by one of us (T. A. C.) in or on the mere during a long period of years, and a preliminary list of the Lepidoptera collected on the fringe of the mere by Mr. A. W. Boyd.

We owe especial gratitude to the Right Hon. Lord Egerton of Tatton, and to the Honourable Maurice Egerton, not only for permission to undertake the work on private waters, but for the interest they have invariably shown, and for the kindly assistance they have rendered during operations which have, of necessity, been carried on over a prolonged period. Through their kindness we have had the frequent use of a boat and the help of a gamekeeper, Mr. John Millington, who has, whenever we required it, rendered us valuable service.

Messrs. A. W. Boyd and Travers Hadfield have accompanied us and shared in the work of collecting and observing on many of our visits, and several specialists, whose assistance will be acknowledged in the proper place, have given advice and practical help in working out the collections in various branches.

We also desire to express our thanks to Mr. E. Moore Mumford, M.Sc., for kindly undertaking a chemical analysis of our samples of the water, and to Mr. W. Riddell, M.A., for much valuable help and criticism.

#### DESCRIPTION OF THE MERE.

Rostherne Mere is a large sheet of water in the north of Cheshire. It lies a little over ten miles S.W. of Manchester, three miles S.S.W. of Altrincham, and three miles

N. of Knutsford. The lake itself, and the whole of the land surrounding it, is on the estate of Lord Egerton of Tatton. No road, or even public footpath, touches its banks, and in consequence its fauna is comparatively undisturbed and its waters uncontaminated. Of its circumference of about 3,160 yards, woods and willow beds bound it for nearly 2,300 yards.

The surface area of the water at the time of the last ordnance survey revision—March, 1893—was 118·252 statute acres. Henry Green, in “Knutsford, its Traditions and History,” 1859, gives the area as 115 acres, which may have been then correct, but the statement in Bagshaw’s “Cheshire Directory” for 1850, that it is 156 acres is manifestly erroneous. Green’s calculations were probably based on an informal survey conducted by Captain Cotton about the year 1840.

Measurement on the 25-inch Ordnance Survey gives the greatest length—from the north to a little west of the outflow brook—as 3,850 feet (1,283 yards), and the greatest breadth at right angles to this line as 2,100 feet. This only differs slightly from Captain Cotton’s measurements of 1,250 and 695 yards. It is quite possible that the area has increased to this extent in seventy odd years.

In 1893 the surface level was 67 feet, but there is no record of the level at the time of Cotton’s investigations. Although the drainage area is inconsiderable, the water will rise several feet after heavy rains, considerably increasing the area in one or two places where the banks are low. In May, 1913, practically the whole of the Gale Bog, over six acres in extent, and an even larger area at the south end of the mere, were submerged for many days.

The mere lies in a great hollow, a deep depression or subsidence. Except at the south-west, where the inflow

brook enters, and at the south-east, where the outflow leaves, the 100 feet contour is never more than 600 feet distant from the margin ; in places it approaches within 300 feet.

The village of Rostherne, on the south bank, rises from 100 to 160 feet, and the nearest farm on the north stands at an altitude of 120 feet ; the Manor House, on the south-west, is 167 feet, or 100 feet above the normal surface of the mere. The watershed is in most places considerably under 200 feet, and thus the drainage area is small.

The lake is fed by a few springs and small streamlets and one fair-sized stream, Rostherne Brook. This brook rises in Tabley Moss, about two miles south of the mere, at an altitude of 170 feet. After passing Mere Mere (167 feet) it falls rapidly through a clough or dell, Rostherne Banks, and enters the mere just below the manor. The next stream of any size has a length of little more than 1,000 feet, and flows through Harper's Bank Wood. The bed of Rostherne Brook is mostly fine gravel and sand, that of the smaller stream almost entirely sandy.

The outflow, Blackburn's Brook, is at first a wide sluggish stream, with banks which at one time were evidently cut straight and protected, so as to drain the artificial osier bed on its right. It flows from the south-east bend of the mere in an easterly direction, and then bends northward until it joins the Birkin, a tributary of the Bollin. The Bollin formerly flowed into the Mersey, but now empties its waters into the Ship Canal, thus presenting an additional obstacle to the ascension of salmonoid fish.

The deepest sounding obtained by Captain Cotton was 103½ feet, but our deepest, a little to the south of the centre, was only 100 feet 6 inches. Mr. James Kenyon,

according to a rough chart he sent to the *Fishing Gazette*, March 30th, 1907, found a depth of 105 feet, but the surface of the mere may then have been higher. The late Robert Okell<sup>1</sup> thought, from memory only, that the depth was more like 130 or 140 feet, and Mr. Anthony Carter fancies that his father talked of even deeper holes, but it is certain that it is now nowhere much over 100 feet.

The soundings show steep descent on the south-west, where the ground rises rapidly from the bank to the church. The drop from 20 to 80 feet is very rapid, but a considerable area in the centre is between 80 and 90 feet.

At the south-east, towards the mouth of the outflow brook, the mere is shallower, many acres being less than 20 feet in depth.

At the north, where the lake narrows, it is bounded by a moss or bog, known as the Gale Bog. Here there is the appearance of a secondary subsidence, but of no great depth. A bar or shallower ridge divides the two portions of the mere; the depth is about 14 feet at the bar, and falls to the north again to 22 feet. Local tradition insists that the depth close to and under the bank at the edge of the Gale Bog is 40 feet, but this is incorrect. Although the peaty edge of the bog slightly overhangs deep water in places, our soundings only give 18 feet at the immediate edge.

To the south of the Gale Bog, on the western margin, is a small inlet or pond, marked on the map with the word "Sluice." No real sluice exists now, but it suggests that at one time this pond was used as a "stock pond," and is probably artificial; it is connected by a narrow, though deep, opening with the mere.

Except at the Gale Bog end, where the soil is almost entirely peat, the margin is sandy, but most of the bottom

<sup>1</sup> *Fishing Gazette*, April 6th, 1907.

deposit is fine oozy, black mud. A small sandy delta has formed at the mouth of Rostherne Brook, and is a favourite resting place for gulls and wading birds.

The marginal reed-bed on the east and south-east extends for about 1,200 yards, and is in many places more than a dozen yards broad. On the south margin there are two beds of about 170 and 100 yards, and on the west, three, extending for about 260, 130, and 130 yards respectively. These extensive beds of reeds and other aquatic plants have a distinct bearing upon the character of the vertebrate and invertebrate inhabitants and visitors.

The mere lies in a cup-shaped  
*Geological Formation.* hollow in the Triassic Red  
 Marl of the Keuper Series of  
 the New Red Sandstones. Overlying the Marl is the Drift—Lower Boulder Clay and Sand. At a short distance from the western margin of the mere is the southerly extremity (so far as has been ascertained) of a “great Warburton fault,” which runs in a south-easterly direction from the Lancashire Coal Fields.

Hull<sup>2</sup> says :—“ It appears to be a continuation of the ‘Cannel-fault of Ince,’ as both lie in a direct line ; but it is remarkable that the directions of the down-throw are reversed....it ranges towards Rosthern (*sic*) Lake, though I doubt if it has had any connexion with the position of the lake itself.”

Within half a mile west of the mere it separates the Red Marls from the Waterstones, which were formerly quarried at Millington, a mile from the mere. The salt deposits lie in the Red Marls to the south of Rostherne ; the Cheshire rock-salt was first discovered at Marbury, seven miles south-west, and brine is now pumped at Holford, which is only five miles to the south.

<sup>2</sup> Edward Hull. “The Geology of the Country around Altrincham, Cheshire.” *Memoirs of the Geological Survey*, 1861, p. 7.



G. W. Ormerod<sup>3</sup> says:—"The exact northern extent (of the salt deposits) has not been determined. It is probably the line of fault before mentioned which passes from the South Lancashire coal-fields by Warburton and Rostherne in a south-easterly direction to the Rudyard fault." He further states that brine was met with at Woolstone, near Warrington, which is west of the fault, but considerably to the north of Rostherne, but the discovery of brine within recent years at Warburton proves that there are beds north and east of the fault. We may then admit the probability of salt below the marls in the immediate neighbourhood of Rostherne, a supposition which has considerable bearing upon the possible origin of the mere.

Hull<sup>4</sup> says:—"The rather uniform features of the landscape are agreeably varied by the frequent occurrence of little lakes or *meres* in artificial or natural hollows.

"The largest and most interesting of those in this district is Rosthern Mere, a natural lake about 100 feet in depth, its bed being about 20 feet below the sea-level, occupying a deep depression excavated in Boulder clay and sand. The other meres, as far as I have been able to ascertain, are situated in the same Post-pliocene formation, as are also those of De la Mere Forest and Ellesmere.

"It is, however, a remarkable fact, that these natural reservoirs are all (I believe) situated upon the Red Marl, that formation which holds the beds of rock salt. Now this mineral, whenever rainwater has access to it, is liable to be dissolved, the brine being carried away in under-currents. Such a process long continued would probably result in the production of hollows, for wherever the

<sup>3</sup> "Outline of the principal Geological features of the Salt-Fields of Cheshire and the adjoining districts." *Quart. Journ. Geol. Soc. of London*, IV., 1848, 281.

<sup>4</sup> *Op. Cit.*, p. 1.

melting of the salt proceeded most rapidly, there the subsidence would be greatest. It may thus have happened, at least in some cases, that hollows in the surface of the ground thus produced have given origin to the lakes of Cheshire, and to this cause Mr. Ormerod appears inclined to attribute Budworth Mere and Pickmere, which lie a short distance to the north of Northwich, and certainly within the limits of the great beds of rock salt”

This theory, suggested by Ormerod *Origin of the Mere.* and upheld by Hull, has been generally accepted. It is largely supported by the subsidence of land, noticed many years ago and still going on, in those parts of the Cheshire basin where brine is artificially pumped. The main subsidences are above the actual rock salt mines, into which, after much of the rock salt has been removed, water is allowed to flow, dissolving the remaining beds and the pillars which were left to support the roof of the levels. When this is pumped out as brine there is usually a surface subsidence. It is argued, reasonably, that dissolution of salt has been in operation naturally for ages, for brine springs were known centuries before rock salt was discovered. Water constantly percolated through the marls and reached the salt seams, slowly dissolving the salt, and natural subsidence was liable to follow whenever the water was not in sufficient quantity to support the upper strata. No more satisfactory explanation of the formation of these deep, rounded, cup-shaped Cheshire hollows has been suggested.

Reference to the map of Rostherne Mere, which we have prepared, shows that its bed consists of two distinct depressions, a large southerly one (the main lake basin) and a small northerly one. We accept Ormerod's explanation of subsidence, consequent upon the dissolution

of salt from the strata underlying the bed rocks of the mere, as certainly applying to the main southerly basin. The small northerly depression is just as certainly a subsequent formation, and the barrier separating it from the southerly basin must at one time have marked the north boundary of the mere. We have not yet determined how this depression was formed. The bottom is composed entirely of peat, and the banks of the mere surrounding it are composed of *Sphagnum* peat overlaid in parts by clay derived from the surrounding country. Before the formation of the second depression, the banks of the north end of the mere must have been a peat bog and the birch wood now to be found on the Gale Bog marks the highest development of the peat. The subsequent depression of this peat mass may have been formed in a similar way to the main basin of the lake, *i.e.*, by subsidence due to the removal of salt from the underlying rocks, or it may have been formed in a manner comparable to that suggested for the formation of the shallow pools which have been and are being formed at the present time in the Delamere Forest country, where salt is not known to occur. The character of these forest pools differs essentially from that of the northern and eastern meres, and Hodge<sup>5</sup> suggests their formation in the following way. A *Sphagnum* peat bog has first developed on the surface sand which lies above the Trias in this neighbourhood. Subsequently, by the action of superficially subterranean water, this sand has been slowly washed away, resulting in the subsidence of the peat and the formation of a shallow pool. Mr. R. S. Adamson hopes to be able to decide this point, but his researches are not yet completed, and a definite statement of the origin of the northerly basin of the mere cannot yet be made.

<sup>5</sup> *Lancashire Naturalist*, April and May, 1912.

Remains of Red Deer, *Cervus elaphus*, almost certainly from the Drift, have been recovered on at least three different occasions from the bed of the mere. Particulars of these were supplied by the late Earl Egerton,<sup>6</sup> and one of the antlers, which we have seen, is very massive in the beam. The earliest find consisted of part of a skull with both antlers attached. About the year 1880 a vertebra was found, and in 1883 a second broken skull with a single horn. All were brought up on fishing lines, the captured fish having entangled the lines round them.

When trolling for pike on February 28th, 1914, Coward's hook caught on an obstacle in about 20 feet of water; when the line was reeled in, the rib of a Red Deer came up attached to the hook.

References to Rostherne Mere in older *Literature*. literature have very little bearing upon the study of its fauna, and most of them are unimportant. Indeed, in the Domesday Book account of "Rodesthorne" the lake is not even mentioned. Beaumont<sup>7</sup> translates it as below:—

"The same Gilbert holds Rodesthorne. Ulviet held it. There is i virgate of land rateable to the gelt. The land is i carucate. It was waste. There are ii acres of wood. In King Edward's time it was worth iv shillings."

Daniel King<sup>8</sup> gives some information, but of a very general character.

"Of Waters, there is also a great store, in manner of Lakes, which they call Meres; as *Combermere, Bagmere, Comberbach, Pickmer, Ranstorn Mere, Okehanger-Mere...*

<sup>6</sup> *Proc. Lanc. and Cheshire Antiquarian Soc.*, II., 116.

<sup>7</sup> Beaumont, William. "A Literal Extension and Translation of the portion of Domesday Book relating to Cheshire and Lancashire," p. 53. Chester, 1863.

<sup>8</sup> "The Vale-Royall of England, or The County Palatine of Chester, illustrated." London, 1656.

wherein aboundeth all kinds of Fresh-Fish ; as *Carpes, Tenches, Bremes, Roches, Daces, Trouts*, and *Eeles*, in great store."

The earliest reference of any importance which we have discovered is in an ancient book on fishing by Richard Brookes, published in 1740<sup>9</sup> ; the extract supplying a most useful early account of the Smelt is given in full when referring to that fish.

Aiken<sup>10</sup> who wrote a few years later than Brookes, either lacked knowledge or took no special interest in fish. He merely states that "Rosthern-meer" is "well furnished with fish."

Later references to the fauna in periodical or other literature are mentioned under the various species.

Folk-lore and tradition, as might be expected, have arisen in the neighbourhood of so large and deep a lake, but the various stories have more interest for the antiquarian than the zoologist. Even now the tale exists that the mere has no bottom, or rather that the actual bottom has never been discovered, but the most ignorant of the natives has probably ceased to credit the tradition that an underground passage connects the lake with the sea. Through this passage, so the story goes, a mermaid travelled at certain periods, and some connect her presence with one of the bells from the church. This bell, so we are told, was obstinate and apparently objected to being placed in the church belfry, whereupon one of the annoyed workmen consigned it to the Devil. The Devil accepted it, and the bell at once tore itself loose from its fastenings, bounded down the slope and buried itself in the deeps. The mermaid rings the bell once a year, but the exact

<sup>9</sup> "The Art of Angling, Rock and Sea-Fishing ; with the Natural History of River, Pond, and Sea-Fish." London. 1740.

<sup>10</sup> "A Description of the Country from thirty to forty Miles round Manchester." London. 1795.

date differs according to the tales of the various people who never hear it; it varies between Easter Eve and Christmas Eve. A reference to the tradition can be found in Henry Green's "Knutsford."<sup>11</sup>

It is interesting to note that a very similar legend is told of the largest of the Cheshire meres, Combermere.

#### TEMPERATURE.

The temperature of the surface water was taken on the occasion of each visit to the mere from May, 1912, to November, 1913. The temperatures are set out on the following chart, and the resulting curve gives a very fair idea of the range of temperature to which the mere is subject. The winter of 1912-13 was comparatively mild, and the temperatures recorded were never very low. On the other hand, we believe that in many years the temperature of the water in the summer must rise above the highest figures we obtained, 19° C. The maximum temperature of 19° C. was reached in July, 1912, and August, 1913, and the minimum, 4.2°C., in January and February.

In the matter of temperature, Rostherne Mere shows a similar range to that noted for Lough Neagh by Dakin and Latarche,<sup>12</sup> and a considerably greater range than that exhibited by the Scotch lakes, in which the annual range is only about 5—15° C. This is to be explained by the fact that the Scottish lakes are very much deeper than either Lough Neagh or Rostherne, and have relatively much more steeply sloping shores. The annual range of temperature is an important factor in determining the nature of the plankton of a lake, and it is quite possible that the absence of "water bloom" in the Scotch lakes and its regular

<sup>11</sup> Green, H. "Knutsford, its Traditions and History," p. 92. London, 1859.

<sup>12</sup> *Proc. R. Irish Acad.*, Vol. XXX., Sec. B, No. 3, 1913.

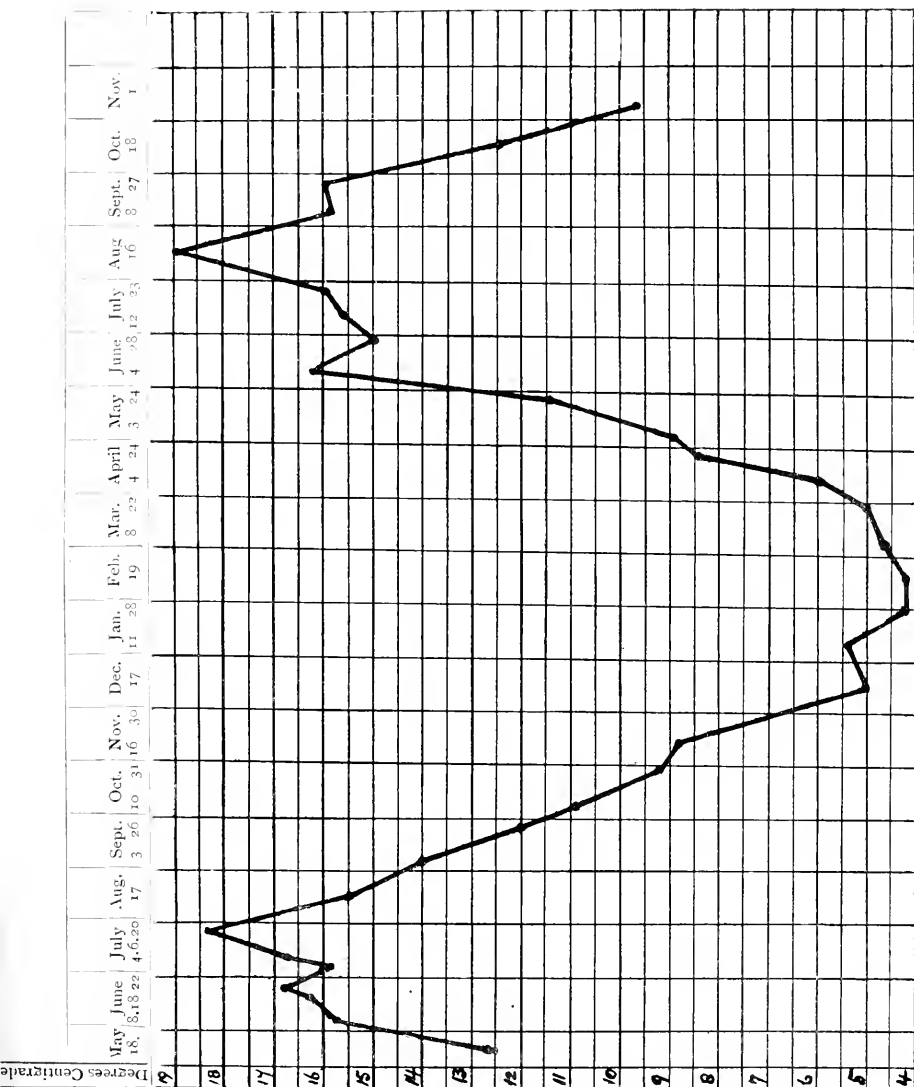

Rostherne Mere : Temperature Chart, May, 1912—November, 1913.





appearance in Lough Neagh and Rostherne Mere may be partly explained by the differences in the annual range of temperature, more especially to the difference in the maximum temperature reached in both sets of lakes. The somewhat irregular nature of the curve in both the summers concerned is possibly to be explained by some such cause as the presence or absence of recently-fallen rain or excessive inflow water at the times of our visits.

#### CHEMICAL COMPOSITION OF THE WATER.

One of the most noteworthy features of the fauna of Rostherne is the presence in its waters of the Smelt, *Osmerus eperlanus*, a Salmonoid fish usually associated with estuaries. We have no direct knowledge as to how it got there, though it is possible that it was introduced into the mere at some time or other and has become acclimatised. There is no inherent difficulty in this possibility, as we know that in many of the fresh-water lakes of Sweden it is resident all the year round. Its occurrence in Rostherne, however, has given rise to interesting, if groundless, speculation, and two main opinions have been held to account for its presence there. Firstly, Rostherne has been supposed to be in some way or another influenced by the tide, and secondly, by reason of its origin as a subsidence or dissolution basin on strata overlying deposits of rock salt, it has been alleged that, at the bottom of the mere, the water is salty, due to the solution of rock salt from the underlying strata, and thus affords a suitable home for Smelt. No evidence has, so far as we are aware, been brought forward to support either of these opinions. They seem to have been manufactured to fit the case, and we can find absolutely no evidence in support of the first of them. As for the second, it seems almost obvious that, if the bottom layer

of water were dissolving salt from the underlying rocks, the process of diffusion would, in a comparatively short time, cause the effects of the presence of salt to be evident all over the mere, and to be detectable at the surface by merely tasting the water. In order to settle the question we collected samples of both surface and bottom water for analysis. The surface sample was taken near the centre of the lake, one of the bottom samples at a depth of 80 feet, and the other at a depth of 40 feet near the outlet brook. We are indebted to Mr. E. Moore Mumford, M.Sc., of the Frankland Laboratory at the University, for kindly undertaking the analysis of the samples for us. His results are given in the following table:—

## ANALYSIS OF WATER FROM ROSTHERNE MERE

(parts per 100,000).

|  | Surface.         |     | 40 ft. |     | 80 ft.           |
|--|------------------|-----|--------|-----|------------------|
| Nitrogen as:—                              |                  |     |        |     |                  |
| Free and Saline Ammonia .....              | 0'008            | ... | 0'012  | ... | 0'016            |
| Albuminoid Ammonia .....                   | 0'012            | ... | 0'011  | ... | 0'010            |
| Nitrites.....                              | very faint trace |     | nil    |     | very faint trace |
| Chlorine (ionised) .....                   | 4'00             | ... | 3'85   | ... | 2'80             |
| (expressed in terms of Sodium Chloride)... | 6'61             | ... | 6'35   | ... | 4'62             |
| Oxygen (absorbed, 4 hours) .....           | '46              | ... | '46    | ... | '46              |
| Hardness, calculated in terms of Calcium:— |                  |     |        |     |                  |
| Temporary .....                            | 4'19             | ... | 4'19   | ... | 4'06             |
| Permanent .....                            | 2'48             | ... | 2'61   | ... | 1'70             |

Looked at in the first place from the point of view from which it was taken, namely, to determine whether there was any trace of the influence of the sea on the lake, and also whether the bottom layers contained a large amount of salt in solution from the underlying rocks, the

analysis gives conclusive negative evidence in both cases. The chlorine in sea water is about 18·85 parts per 100,000, so that an infiltration of only 1 per cent. of sea water into the mere would increase the chlorine in its water by 18·85 parts per 100,000. The chlorine at no depth exceeds 4 parts per 100,000, which is regarded as quite a normal amount for pure fresh water. We may, therefore, dismiss the idea that the lake is subject to marine influence as simple folk-tale. The fact that the chlorine is greater in amount at the surface than at the bottom, and that, moreover, at the surface it is no more than normal, also does away with the idea that the bottom water of the mere is salt by reason of the solution of rock salt from the underlying strata.

We may note in passing that the water possesses only five degrees of total hardness, and may, therefore, be regarded as quite a soft water.

The analysis brings out another interesting point, namely, that the total salts present in the water, as expressed in the figures for the chlorine content and the hardness (both temporary and permanent) are relatively greater at the surface than at the bottom, viz., 13·28 parts per 100,000 at the surface, as against 10·38 at the bottom, showing that the water at the bottom of the mere is actually fresher than at the surface. Dr. Hickling has suggested to us that this difference is the result of evaporation and the consequent concentration of the salts at the surface.

The analysis, so far, fulfils the purpose for which it was made, but further consideration of the figures obtained reveals features of considerable interest. The amount of oxygen absorbed in the course of the analysis suggests the presence of large quantities of organic matter in solution. According to the table of standards devised by Frankland

and Didy, water absorbing more than 30 parts of oxygen per 100,000 must be regarded as organically impure water. This is borne out by the high amount of albuminoid ammonia (*i.e.* ammonia derived from the organic matter in solution in the water) present. From what is this excess of organic matter derived? We may here point out that Rostherne Mere is extremely rich in plankton at all times of the year, and that a certain part of the organic matter in solution must be derived from the countless number of organisms which die and sink to the bottom, there to decompose, but we believe that the greater part of the organic matter revealed by the analysis is derived from the peat hole at the north end of the lake. The general flow of water in the lake will allow of the peaty water from the north end influencing the entire water of the mere.

Regarded from the public health point of view and judged from the chemical standpoint only, the water looks suspicious. But we can see no possible source from which the mere can be polluted, and the absence of nitrites in the water supports the idea that the lake is uncontaminated by sewage or pollution of any kind. We have not had a bacteriological examination of the water of the mere made, and, of course, without such an analysis it is impossible to be certain that no pollution exists. We merely give our opinion that there does not appear to us to be any possible source from which pollution can be derived. The pollution or otherwise of water may be partially judged from a consideration of the amounts of free and albuminoid ammonia present. In sewage-polluted water free ammonia is generally far in excess of the albuminoid ammonia, while, on the other hand, a high amount of albuminoid ammonia, associated with a low percentage of free ammonia, suggests vegetable con-

tamination. In Thresh,<sup>13</sup> we read that peaty water may contain '01 parts per 100,000 of free ammonia, associated with more albuminoid ammonia, and yet be pure, and an analysis of peaty water given there shows '001 of free ammonia and '024 of albuminoid ammonia per 100,000 parts of water. We take it, therefore, that Thresh means to convey that in peaty water the albuminoid ammonia is always in excess of the ammonia. This is borne out by an analysis of peaty free waters given by Dachnowski.<sup>14</sup> For pure bog waters his figures are '519 parts of free ammonia and 1'034 parts of albuminoid ammonia per 100,000 parts of water, and for lake water on the same island as the bogs and presumably influenced by them the figures are '295 and '45 parts per 100,000 respectively. In both these cases the albuminoid ammonia is in excess of the free ammonia, though not to the extent that Thresh's figures give, where the albuminoid ammonia was twenty-four times as great as the free. Still they bear out Thresh's statement that, in cases of vegetable contamination, the albuminoid ammonia is in excess of the free. In the present instance, the amounts of free and albuminoid ammonia are more or less equal, and there is, therefore, an excess of free ammonia, over and above that due to the peat contamination, to be accounted for. We believe that this excess of free ammonia is derived from the action of the bacteria of putrefaction, which, acting upon decaying organisms, liberate free ammonia. We have already pointed out that Rostherne Mere is very rich in planktonic organisms, and these, dying and sinking to the bottom, provide the material upon which the

<sup>13</sup> "The Examination of Water and Water Supplies," 2nd edit. London, 1913.

<sup>14</sup> *Botanical Gazette*, July, 1911.

bacteria act. We believe, therefore, that the excess of organic matter in solution in the water of Rostherne Mere is derived from two sources, the peaty water from the small northerly basin, and the abundance of decaying animal matter with which the bottom of the mere must be covered.

We have entered at some length on the discussion of the chemical composition of the water, because it seems possible that later on we shall find that it has an important bearing on the nature of the plankton of the lake. We do not propose to discuss that question at present.

#### METHODS OF INVESTIGATION.

Our methods of investigation of the fauna have been as follows. One of us (T. A. C.) has had the mere under frequent observation for upwards of thirty years, and within the last ten years his visits have been more or less regular, with the object of observing the vertebrate fauna.

For eighteen months, from May, 1912, to November, 1913, approximately fortnightly visits were made to the mere for the especial purpose of collecting the plankton. At the same time a little dredging and shore collecting were done and these are still being carried on. In making our collections of the plankton, we used three nets, two for surface hauls and a Nansen net, kindly lent by the Lancashire and Western Sea Fisheries Committee, for vertical hauls. The latter were made in the deep water of the mere, at depths varying from 85 to 95 feet, with the object of making a quantitative examination of the plankton by the counting methods. The two nets used for surface hauls were a coarse one made of muslin, and a fine one made of Muller's gauze, No. 20. They were towed at the surface of the water in the centre of the mere, the fine net for five minutes and the coarse one for ten minutes.

Though at the time of our investigations we were unaware of Wesenberg-Lund's arguments for the use of nets of varying degrees of coarseness, if a fair idea of the nature of the plankton is to be obtained, our experience prove the wisdom of his contention. We have found the contents of the fine and coarse nets, hauled at the same time, to differ very widely, and if we had only used a fine net, our ideas as to the relative abundance of the larger organisms, such as the Crustacea and larger Rotifera, would have been quite erroneous. We suppose that the fine net very rapidly has its meshes choked with small phytoplanktonic organisms, and that, though nominally towed for five minutes, it is actually straining water for a very much less time. After the meshes of the net become choked, the net plus the contained water acts as a solid object pulled through the water, and instead of straining, it merely pushes the water aside. In this way the large organisms are not captured, and an erroneous idea of their relative abundance results.

Although we admit that a vertical haul, in which the organisms are duly counted, conveys the only exact idea of the relative abundance of the planktonic organisms at a given time, we submit that regularly collected surface hauls, with both fine and coarse nets, give a very fair idea of the seasonal changes and periodicity of planktonic organisms. Our surface hauls were made entirely from the qualitative point of view, but, in so far as we have examined them, we believe also that they present an accurate picture of the variations in number and kind of the organisms which constitute the plankton throughout the year.





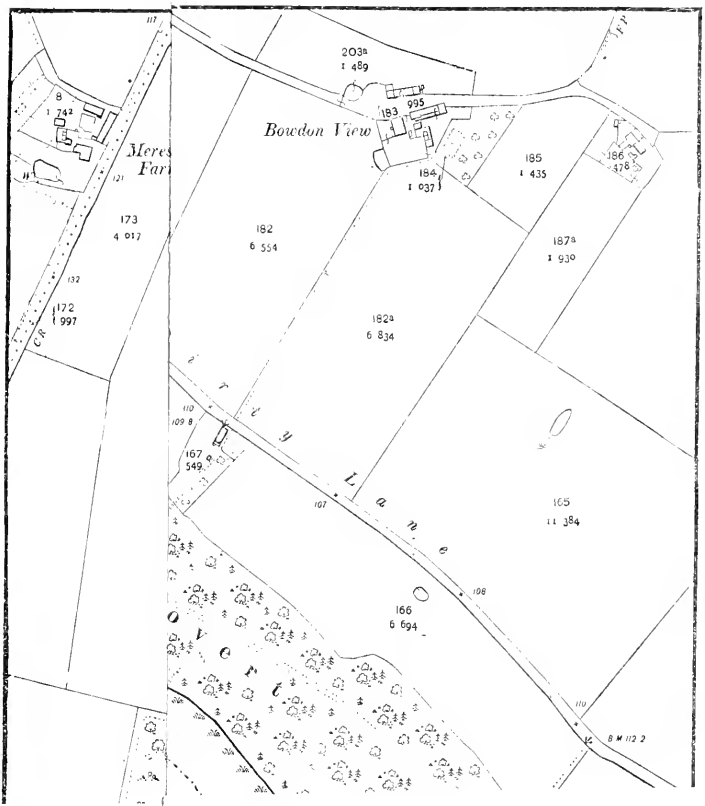

BATHYMETRIC MAP OF ROSTHERNE MEKE

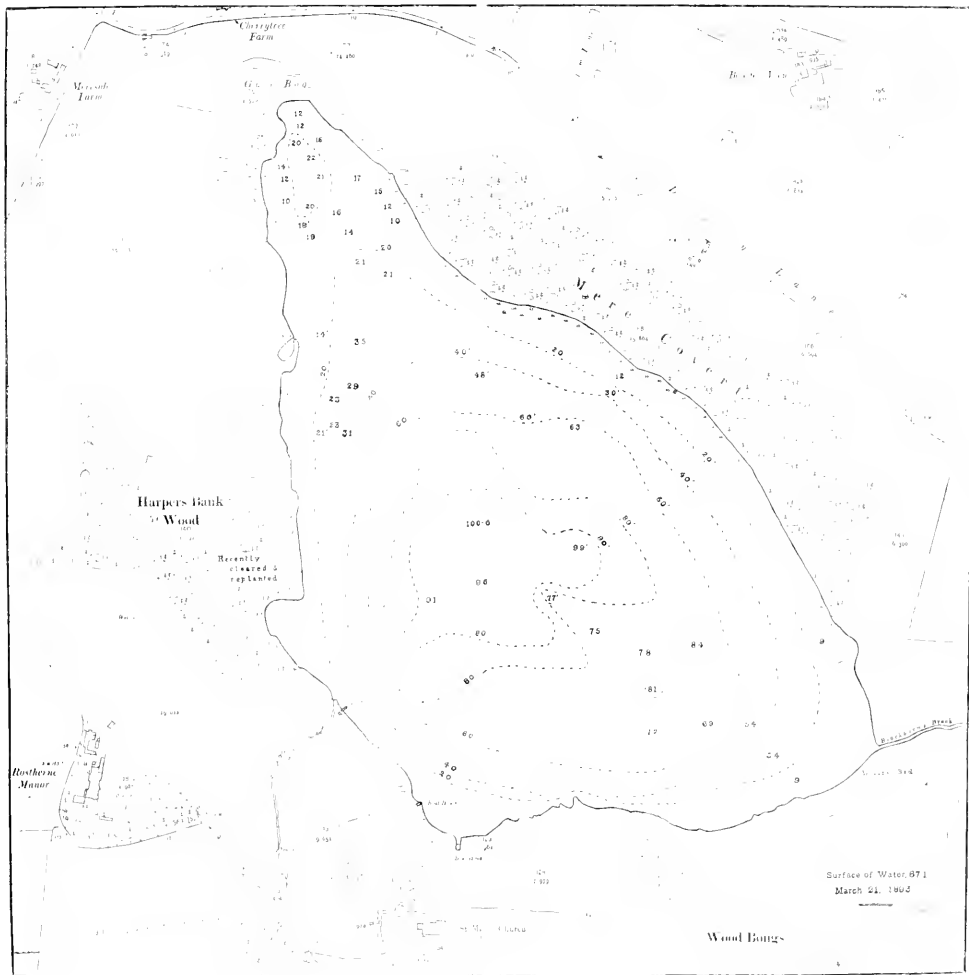

## IX. Faunal Survey of Rostherne Mere.

### II. Vertebrata.

By T. A. COWARD, F.Z.S., F.E.S.

*(Read March 24th, 1914. Received for publication March 31st, 1914.)*

In considering the vertebrate fauna of a restricted water area such as Rostherne Mere, one of two courses could be followed: either to include all the species, in addition to the fish, which occur within any given distance of the bank, many of which may have no real connection with the mere at all, or to restrict our attention to those forms which are in one way or another actively influenced by the presence of the water. We have chosen the latter course, but have allowed ourselves considerable latitude in estimating how the various species are influenced.

Thus the Mammalian list is a small one, although many purely terrestrial forms, whose habitat is close to the margin of the mere, may use it regularly in their search for water. They are not, however, specially attracted to or by the mere; a pond or streamlet would serve their purpose just as well.

Amongst the Birds again there must be many which, passing from point to point, cross the mere, whilst others may actually nest in trees which overhang the water—their connection with the water is purely accidental. They are but a portion of the large and varied avifauna which inhabits the whole country round about the mere. There are some which feed in the waterside trees, or even in the more aquatic vegetation, but merely by chance,

*May 30, 1914.*

and not because they are specially attracted by the aquatic insects. There are others, however, which so habitually resort to the reed-beds for food that they must have considerable bearing upon the status of the various species of reed-haunting invertebrates. Some habitually nest in aquatic vegetation, whilst others again are attracted to the reed-beds for purposes of gregarious roosting at times of migration. All these birds whose connection with the mere we may term intentional and not accidental we have considered.

#### MAMMALIA.

Daubenton's Bat, aptly  
*Myotis daubentonii* (Kuhl). called the Water Bat by  
the late Major Barrett-  
Hamilton, who adopted the name from the German  
*Wasserschleiermaus*, must, unfortunately, only be included  
provisionally in the Rostherne fauna. We have never  
actually seen this aquatic bat flying over the water of the  
mere. The explanation is, probably, that we have not  
been at the right spot at suitable times and seasons, for  
the species occurs in the immediate neighbourhood. We  
have seen it on the river Bollin, less than a mile from the  
mere on the one hand, and in abundance on pools on  
Knutsford Moor, and we have had specimens taken from  
a tree on the margin of the neighbouring mere at Tatton.  
It is plentiful in Dunham Park and other places at no  
great distance, and it would be remarkable if it did not  
occur in some numbers at Rostherne.

The habit of this bat is to fly low over the surface of the water feeding on aquatic flies, which it apparently occasionally picks from the surface and constantly captures as they fly a few inches above the water. When it is numerous it must destroy multitudes of night-flying

dipterons, which, we may guess, would escape the attacks of insectivorous birds.

Matschie, in Brauer's "Die Süßwasserfauna Deutschlands" (1909), includes two other bats, one of them the Whiskered Bat, but the insectivorous habits of any of the *Vespertilionidae* lead them occasionally to the presence of water, and all might be included. We have seen the Noctule flying high above Rostherne, and other unidentified species hawking near the margin, but their presence is not habitual like that of the Water Bat.

The Water Shrew

*Neomys fodiens bicolor* (Shaw). occurs in the outflow, Blackburn's Brook,

but we have not met with it in the mere itself. The brook is broad and slow-flowing but not very deep; it is an ideal habitat for this shrew, which feeds on small crustaceans, insects and molluscs.

It is doubtful if any

*Lutra lutra* (Linnaeus). Otters reside permanently on the bank of the mere, but the animal is a fairly constant visitor. It occurs not infrequently on the rivers Bollin and Birkin, and at Tatton Mere. In 1866 the skull and skin of an Otter which had been killed at Rostherne were exhibited at a meeting of the Manchester Literary and Philosophical Society,<sup>1</sup> and about the year 1880 one which had been trapped on the mere was kept alive in Rostherne village for some time. This water, however, does not appear to be so attractive to the Otter as the neighbouring mere in Tatton Park, for it is more unusual to find otter-killed fish at Rostherne than at Tatton, nor have we heard the animal whistling in the reed-beds as we have done after dark at the latter mere. At Redesmere the Otter feeds upon the fresh-water

<sup>1</sup> 1866. Proc., V., 122.

mussels, *Anodonta cygnea*, but we have not found the shells of this mollusc with tooth-marks of the Otter at Rostherne. Possibly the greater depth of the water makes the capture of the fish more difficult than in the shallower meres, but this would not apply to the mussels which are easily seen in the shallower portions.

The Water Vole is decidedly more abundant along the banks of the outflow, Blackburn's Brook, than on the edge of the mere. It feeds on the edge of the brook and in the osier-bed at the south end of the mere. We have never found its spherical nest, supported on a raft of cut reed-stems, in the reed-beds at Rostherne, though we have occasionally found it on other Cheshire meres ; at Rostherne the nests appear to be underground.

The Brown Rat is at once the most abundant and troublesome of the aquatic mammals. It is a common and destructive pest in all game-coverts, and those which surround Rostherne Mere are not exceptions. It burrows in the banks, no doubt aiding their erosion ; it lives in the entangled roots of the waterside alders, and raids the nests of birds which breed in the reeds. Its omnivorous tastes lead it to destroy vegetation as well as to kill and devour other animals. The eggs of Mallards, Coots and other birds are sucked by the Rat, and on one occasion we heard a scuffle in the reed-bed and saw a full-grown Rat emerge, followed by an irate Coot ; the young Coots had hatched a day or two before and were scattered amongst the reeds near the nest, and on this occasion the parent bird had probably driven the intruder away. Close to the hole, into which the Rat went so soon as it saw that it was observed,

were the skin and partially picked bones of a young Rabbit. The influence of so many Brown Rats as occur round the mere must be far reaching but is difficult to estimate ; there is no question, however, that the Rat is a factor in the regulation of the numbers of many other animals. It is to some extent an alien influence, for it is of comparatively recent introduction.

#### AVES.

A large and varied avifauna inhabits the woods and fields which surround the mere, and the selection of those which can be claimed to be aquatic is exceedingly difficult. Thus the Redbreast and the Hedge Sparrow, much commoner woodland birds than most people imagine, occur so abundantly near the mere that they may easily be responsible for the death of many aquatic animals ; yet it would be absurd to class them as aquatic. Again, in spring, the Willow Wren and Chiffchaff frequently feed in the willows and alders, and even make insect-hunting excursions into the reeds, but it would be hair-splitting to include them and leave out the Garden Warbler and Blackcap, both abundant in Mere Side and Harper's Bank coverts, because we have not actually detected them feeding so close to the water.

The Rook and Jackdaw are common in the neighbourhood, and the Carrion Crow has occasionally succeeded in eluding the vigilance of the keepers for some little time, but although the two former, at any rate, may sometimes be seen feeding on the fields near the edge of the mere, they can hardly be said to have much influence upon its fauna. On some of the less carefully preserved Cheshire meres, however, the Magpie is a constant waterside visitor, and as the bird, although

uncommon, does occur from time to time in the woods, and in the Gale Bog, it may perhaps be included for the same reason. The Magpie may be seen seeking food on the spits of sand or deltas at the mouths of inflow brooks, as well as on sandy margins when the water is low. What it is seeking is not so easy to tell, but it is probably the smaller molluscs, worms, crustaceans and insects which are stranded on the sand.

The connection of the *Sturnus vulgaris* Linnaeus. Starling with the mere is domiciliary rather than gastronomic, although it is not during its nesting season that it becomes a factor in the economy of the mere. The gregarious Starling makes use of the reed-beds for roosting purposes in the autumn, and to a lesser extent in winter. The migratory movements of the Starling are so complicated that it is impossible to say how many of the birds which roost in the reeds are home-bred and how many immigrants or passage migrants, but the numbers which congregate nightly are so immense that we can safely conclude that very many of them have come from abroad. The birds begin to collect in small parties soon after the breeding season is over, and in July and August many repair to the reeds, but the numbers reach their height in September, October and November. In these months the gatherings cannot be counted with anything like accuracy. Even before dusk parties of birds, varying in numbers, begin to come in from all directions; at first they collect in trees in the neighbourhood of the mere, but so soon as a large number have arrived, they go through wonderful concerted aerial evolutions. The flocks will mass together, split up, join again, wheel and change direction with remarkable accord. We have seen a line of many thousands of birds, extending far beyond the



confines of the mere, thus considerably more than a mile in length. When the light is fast fading the birds literally rain down into the reeds, and at once there begins a twitter of thousands of voices, which can be heard at a great distance.

The effect of so large a number of birds resting on the withered autumnal reeds is that many of these are broken down, and later in the season the flocks frequently move to the more sheltered parts of the surrounding coverts. The deposits of droppings by the roosting birds must have cultivating influence upon the vegetation, and may also have effect upon the aquatic fauna of the reed-beds. In sandy gulleries the guano enriches the soil and induces the growth of nettles, chenopodiums, and other rank-growing plants.

Both the Les-  
*Carduelis cannabina cannabina* (Linnaeus). ser Redpoll  
and the Lin-  
net nest in the Gale Bog, but we have not thought fit to include all and every bird which uses this spot for nidification. The Linnet, however, occasionally, at any rate, roosts in the willows when on migration, both in autumn and spring. Mr. Boyd has seen many in September and several in spring, suggesting that passing flocks make use of the shelter and food supplied by the marsh.

Redpolls and more  
*Emberiza schoeniclus* Linnaeus. occasionally Siskins  
are mere-side visit-  
ing finches, but the attraction is the seeds of the alders and birches, and these birds need not be considered. The Reed Bunting, however, in addition to using the reeds for roosting purposes when flocks are arriving in early spring, is a regular nesting species in the aquatic vegetation. At Rostherne, the favoured nesting sites are in the clumps

formed by the cut osiers, but the nest may also be found in rushes or other waterside plants. A few Reed Buntings are usually present throughout the winter, but the majority of the nesting birds leave in the autumn.

The Meadow Pipit, *Anthus pratensis* (Linnaeus), though occurring as a resident in some localities at no great distance from the mere, is only a passing migrant at Rostherne. We have met with it in fair-sized flocks in March and April in the neighbourhood of the inflow brook, where a few odd birds may often be seen in spring either on the sand-spit at the mouth of the brook or on the marshy fields.

*Motacilla flava rayi* (Bonaparte).

*Motacilla boarula* Linnaeus.

*Motacilla alba lugubris* Temminck.

*Motacilla alba alba* Linnaeus.

Four of the Wagtails have more or less regular connection with the mere, either as visitors or resi-

dents. The first of these, the Yellow Wagtail, is a summer visitor and is much less of a waterside bird than the other three. When it first arrives, however, it roosts in the reeds, often with Pies and Whites, and more occasionally with Greys. It is probable that the Yellow Wagtails which thus use the reed-beds are simply resting on passage, and that the local birds distribute almost as soon as they arrive. We have not detected the Blue-headed Wagtail amongst the roosting Yellows at Rostherne, but it is not unlikely that it is an occasional passage migrant.

The Grey Wagtail occurs on passage and also as a not infrequent winter visitor to the margin of the mere. This species may either take a long migratory journey, or the individuals which nest freely on the upland streams may go no further than the lowland streams and lakes.

Birds seen in January or February may be safely looked upon as wintering, but the occasional small flocks in autumn and spring are birds which are merely stopping for rest or refreshment.

The Pied Wagtail occurs as a breeding species in spring, more rarely as a winter visitor, and in considerable numbers as a passage migrant. A favourite nesting place at Rostherne is on the rafters of the boathouse, where, in 1913, we ringed one brood on May 29th, and a second in the same nest on August 16th. In both cases the young were just ready to fly.

The White Wagtail is only known as a passage migrant, and is not common: it is more frequently noticed on the spring than the autumn passage, but the reason of this is that the adult birds in spring dress are more easily recognized than autumn adults or birds of the year.

*Parus major newtoni* Prazak.

*Parus caeruleus obscurus* Prazak.

*Parus ater britannicus* Sharpe and Dresser.

*Parus palustris dresseri* Stejneger.

*Parus atricapillus kleinschmidti* Hellmayr.

It is open to question whether any of the Tit mice should be included

as waterside birds, and yet the visits of two or three species to the reeds are so regular that we are induced to include all the five species which nest in the woods—often within a few yards of the bank. The larger Great Titmouse is not so frequent a visitor to the reeds as the Blue, Coal and Marsh Titmice, and the Willow Titmouse is a much rarer bird than the others, but we have seen it conducting its young through the reeds. The Blue Titmouse is so regular a bird in the reeds that it must have considerable influence in the reduction of those insects

which frequent, and in many cases feed upon the water-side vegetation.

For a similar reason, *Acrocephalus streperus* (Vieillot). it might be argued that we ought to include two of the genus *Phylloscopus*, the Chiffchaff and Willow Warbler, but their visits to the aquatic vegetation are so infrequent that we can look upon them as more or less accidental ; most of their food is obtained amongst the trees and bushes further from and beyond the direct influence of the water. On the other hand, the Reed Warbler is pre-eminently a bird of the reed-beds, nesting and feeding amongst them and seldom wandering far from their shelter. It usually reaches Cheshire towards the end of April or very early in May, but it is not always in a hurry to build its suspended nest, and often both eggs and young birds may be found at the end of June. The bird, as a rule, selects the young reeds for support for its nest ; it weaves the structure round two or three stems. It is an exceptionally deep nest, so that there is small chance of eggs or young being thrown out should wind sway the pliant reeds. In 1913 the reeds were late in growing, and one bird, at any rate, built its nest on the old reeds and succeeded in bringing off its young in safety. Another nested in raspberry canes and brambles, a few feet from the edge of the reeds, whilst others again were singing in the covert at some distance from the water's edge.

The Sedge *Acrocephalus schoenobaenus* (Linnaeus). Warbler is perhaps as plentiful at Rostherne as the Reed Warbler, but it nests in the osier beds, or in the zone of semi-marsh vegetation behind the reeds. It is, however, constantly in the reeds and the food of both species largely consists of insects which, as

larvæ, are aquatic. Like the Reed Warbler, it is only known as a summer visitor.

The Grasshopper

*Locustella naevia naevia* (Boddaert). Warbler is distinctly a marsh bird, but is nowhere abundant in Cheshire. It probably nests in the marshy part of Harper's Bank, where its curious reeling note may constantly be heard in spring.

Of the warblers of the

*Sylvia communis* Latham. genus *Sylvia*, four of which occur regularly in the woods, only one, the Common Whitethroat, can be said to be aquatic in its habits. It is sometimes common in spring in the osier beds at the Gale Bog and the south end of the mere.

The Song Thrush

*Turdus merula merula* Linnaeus. nests occasionally close to the water's edge and even on the ground in the osier beds, but of all the thrushes the Blackbird is the most frequent as a waterside feeder. In winter a few may be generally met with feeding along the landward edge of the reed fringe.

The Whinchat, an in-

*Saxicola rubetra* (Linnaeus). sectivorous summer visitor, nests regularly in the osier beds and feeds on the margin of the mere amongst the aquatic vegetation.

The chief reason

*Troglodytes troglodytes* (Linnaeus) for including the Wren as a factor in the regulation of the numbers of aquatic insects is that few of the woodland birds are more frequently to be met with in the reeds. Not only does it haunt the reed-beds for food, but it may be met with seeking insects amongst

the partly-exposed roots of the alders, or in the thick clumps of rushes or other plants which grow actually in or close to the water. Not infrequently the water gradually washes away the soil from around the roots of the trees which grow at the edge of the mere, and in consequence they fall during strong winds; the Wren almost invariably builds amongst the exposed roots of these fallen timbers.

Naturally all three of  
*Chelidon rustica* (Linnaeus.) our regular summer  
*Hirundo urbica* Linnaeus. swallows are constantly  
*Riparia riparia* (Linnaeus). to be seen over the  
waters during their stay,  
but the numbers vary considerably. When the birds first arrive in spring they remain about the water for a period, the length of which mainly depends upon the date of arrival and the weather at the time. Should a cold snap follow the arrival, the birds find far more food above the water than in the surrounding districts, and they do not distribute to their nesting haunts until a return of more favourable conditions. At night they roost gregariously in the reed-beds. But even after the home-breeding birds have settled down there are repeated arrivals of passage birds, spending a few days in feeding as they move slowly northward, keeping more or less regular pace with the advance of spring. The Swallow nests in the boat-house and a summer-house close to the water's edge, but the House Martin goes further afield. There is no suitable sandy bank of sufficient depth for the Sand Martin. As the summer advances the numbers of all three species which feed above the water increases; local birds begin to pack, families joining families and forming small flocks, and these repair to the reed-beds for roosts; then the passage birds from the north arrive, and in the late

summer immense numbers of Sand Martins, the first of the three to arrive and the first to depart, congregate nightly above the mere, and like the Starlings go through remarkable aerial evolutions.

In 1908 and 1909, according to Mr. Boyd's notes, the Swallows began their autumnal gathering between August 5th and 11th, and by the beginning of September their numbers had become very large. The numbers tailed off towards the middle of the month, and in 1908 all had gone by the 27th. In most years the greatest gathering is during the first half of September. The dates of the House Martin practically correspond with those of the Swallow, for the two species constantly move in company. On the spring passage the Sand Martin is generally most abundant in the latter half of April, although the bird often appears before March is ended. The autumn passage reaches its height during the first few days of September.

The Swift is a frequent visitor

*Apus apus* (Linnaeus). for food, flying high, backwards and forwards, above the mere,

but it neither roosts in the reeds nor nests on the margin, there being no suitable buildings immediately at the edge of the water. Above the mere, however, is the most likely place to see the first and also the last Swifts of the season, so great is the attraction of the insects which fly above the water. Throughout May and early June the numbers vary considerably, and any day birds may be absent or only one or two visible, and the next day scores or even hundreds may be flying with the Swallows and Martins.

The Kingfisher is a common

*Alcedo ispida* Linnaeus. bird at Rostherne; it may be surprised from a perch on the overhanging branch of some tree at any time. No

doubt it destroys numerous fry or young fish, but the bird also feeds upon small crustaceans such as *Gammarus* and *Asellus*, both of which occur in the shallower water near the banks.

Two of the raptorial *Circus aeruginosus* (Linnaeus). birds have special relation to the mere, but both are rare visitors only. The Marsh Harrier has occurred once, at any rate, within recent years. On May 4th and 5th, 1913, Mr A. W. Boyd saw a female or immature male in an osier-bed and reed-bed at opposite ends of the mere, on the later date putting it up three times, once when within ten yards.<sup>2</sup> A search on the following day in all the reeds and willows failed, and no doubt the bird had then passed on.

An Osprey, after having *Pandion haliaëtus* (Linnaeus). been seen fishing on the mere for several days, was shot at the end of April, 1865. It was devouring a two-pound Bream when it was killed. At a meeting of the Manchester Literary and Philosophical Society, on May 15th, 1865, it was exhibited by the late H. Harrison.<sup>3</sup> The bird passed into the collection of Mr. F. Nicholson, and subsequently to the Warrington Museum, where it is still preserved. There is no other record of the Osprey at Rostherne, but in the winter of 1893-94 two were seen on several occasions fishing in the neighbouring mere in Tatton Park.<sup>4</sup>

The Common Heron is a regular Rostherne bird; it is seldom possible to walk round the mere without disturbing one or even several

<sup>2</sup> *British Birds*. VII., 18.

<sup>3</sup> *Zoologist*, 1866. XXIV., 30.

<sup>4</sup> Coward, "Vertebrate Fauna of Cheshire," I., 297.



birds. The stakes in the shallower water, placed there to serve as mooring posts, are used as perches by this bird, but when actually fishing it generally stands in the vegetation at the edge of the mere. The nearest heronry is in Tabley Park, near Knutsford, only a few minutes' flight for these strong-winged birds. On the neighbouring mere in Tatton Park the Herons feed largely on the Bream, a fish which is more plentiful there than in the deeper waters of Rostherne. Examination of the pellets cast up by the Tabley birds proved that Water Voles were largely preyed upon. We have no evidence of the particular animals which are mostly captured at Rostherne.

The Bittern is *Botaurus stellaris stellaris* (Linnaeus), an occasional winter visitor to the Cheshire meres, and when one appears it is seldom alone. Unfortunately the bird is looked upon as a desirable specimen, and one of the pair usually falls to the gun in its wanderings in search of food. This is all the more regrettable because the Bittern almost without question once nested in the reed-beds of the Cheshire meres, and the experience of the last two or three years in Norfolk proves that, if unmolested, the bird will remain to nest. In February, 1900, a Bittern was unfortunately shot at Rostherne, and a second bird was seen a little later; since that date, however, Mr. Egerton has given orders that no rare birds are to be shot, and one which was seen by one of the gamekeepers in February, 1909, was unmolested. The description of the bird was accurate.

The Mute Swan is not looked upon as a wild bird, but it exists throughout Cheshire in a semi-domesticated condition, and the numbers which visit Rostherne vary considerably. Pairs, families or

small parties of Swans fly from mere to mere, and on so large a water the resident birds are often unable to drive away visitors from other places. In most years only a single pair nest, but no sooner can the young fly than two or more families may often be seen on the water. The economic value of the Swan on a small water as a useful factor in keeping in check the rapid growth of the American weed, *Elodea*, is now generally recognised, but although this troublesome weed does occur, the area of deep water is too considerable to be choked by its spread. The Swan is blamed for annoying breeding ducks and other waterfowl and killing the young, but at Rostherne, again, the number of nesting birds is so much larger than of Swans, that little serious damage is done.

It is likely that occasionally wild geese visit Rostherne, but we lack satisfactory evidence of the fact. Grey geese do pass over the county on migration, and we have had reports of birds at Rostherne which sounded like both Barnacle and Brent. On February 8th, 1912, or possibly a day or two earlier, Mr. G. E. Robinson, one of the gamekeepers, saw a very wild bird flying about the mere; he described it to us as like a Canada, only smaller. That this bird was probably a Barnacle is suggested by the fact that on January 18th, 1912, the day following a notable gale which brought many birds inland, one was seen by Mr. M. V. Wenner on Radnor Mere, Alderley.<sup>5</sup> Other birds which were driven inland by the same gale remained in the neighbourhood for some time, and it is possible that the bird which was seen at Radnor wandered from mere to mere, or that others of the same species were moving about Cheshire.

<sup>5</sup> *British Birds*. V., 279.

The Canada  
*Branta canadensis canadensis* (Linnaeus). Goose, although originally an introduced bird, is now so firmly established as a permanent resident that it must be considered as an important member of the avian fauna. One or two pairs nest in most springs on the shores of Rostherne, but it is in autumn and winter, when gregarious and restless, that it is most noticeable. At one time flocks of from 200 to 300 Canadas might be seen on the meres or passing from water to water, but early in the present century a succession of "bad" years considerably reduced the numbers. Lately, however, there has been a rally, and some fair-sized parties have visited Rostherne; seventy, eighty and upwards of a hundred birds have occasionally been counted. These Canadas are very wild and take wing at the approach of a boat with loud clanging cries, but during the moult they will occasionally swim to the side and partially conceal themselves amongst the alders and willows.

Probably the rare visits  
*Tadorna tadorna* (Linnaeus). of the Sheld-duck to Rostherne are incidents of recent years only, for the species has increased enormously in Cheshire, as in other parts of the country. At one time the bird was seldom met with as a nesting species at any distance from salt water, but now-a-days it nests regularly in warrens in inland localities, and one of the earliest spots to be selected was the sandy bank of Oakmere. The increase of the Sheld-duck as a nesting species on the Mersey Estuary and Ship Canal banks no doubt accounts for the wanderings of birds in search of suitable nesting spots and feeding grounds round the Cheshire meres, and the bird is a more frequent visitor to

Marbury and other waters which are nearer to the estuary than Rostherne. On July 21st, 1908, we first saw one on Rostherne; again there was one on the water on April 17th, 1911, and another on March 29th, 1912. On no occasion did the birds make a prolonged stay; they were shy and nervous, and one which we saw depart went off north towards the salt water.

In July and August, 1913, *Casarca ferruginea* (Pallas). a Ruddy Sheld-duck was constantly on the water.

It was wild and shy, flying strongly when approached by a boat, but there is little doubt about its origin. It was almost certainly one of a number bred by Lord Newton on his ponds in Lyme Park. The birds, he informs us, usually leave the park in August, and return about the end of October. Some which left Lyme in the summer of 1913 did not return, and as a bird was shot on Frodsham Marsh on September 4th, shortly after we missed the Rostherne visitor, and two others at Stretford in October, it is probable that the wanderings of this artificially reared bird led to its destruction.<sup>6</sup>

The Mallard *Anas platyrhynchos platyrhynchos* Linnaeus. is, as on other waters, the most abundant duck at Rostherne. There is no regular stocking of the water by hand-reared birds, although a few gathered eggs are sometimes placed under hens, but on one or two other meres birds are reared from bought eggs. On the whole, however, the Rostherne birds show little sign of domestic blood, which is often apparent on waters where birds are artificially reared. Many pairs nest in the coverts and withy-beds round the mere, and almost annually wild birds will mate with the few white

<sup>6</sup> *British Birds.* VII., 118, 199.

call-ducks. The numbers of resident birds are increased in summer by the many broods of flappers, but it is in September and October that the first great change occurs. Probably the immigrants arrive in small numbers throughout the autumn, but towards the end of November there is usually a sudden and large second increase in numbers. It is, however, during a smart frost that the biggest gatherings of Mallards are to be seen. Rostherne, being deep, is the last of the Cheshire meres to be frozen over, and when the other waters are closed by ice great congregations of ducks collect on the still open portions of Rostherne; the Mallards then often number some thousands. On May 6th, 1913, we found a nest of a Mallard in the undergrowth of the Gale Bog which contained eleven normal eggs and one which in colour and shape approached more nearly to the egg of the Tufted Duck. The gamekeeper placed the eggs under a hen, but unfortunately the small egg was destroyed, and we were unable to discover if it was a case of dual ownership.

*Anas crecca crecca* Linnaeus. Although the Teal nests in considerable numbers in Tatton Park, and is often present on Tatton Mere in flocks consisting of forty, fifty or more birds, it is not an abundant duck on Rostherne. It is, however, frequently present in small numbers from autumn until spring; occasionally a "spring" of half a dozen or more birds will remain on the water for several days together, but as there is, all through the winter, frequent movement between Rostherne and Tatton, birds which are present one day may be absent the next

*Anas penelope* Linnaeus. The Wigeon is both a passage migrant and a winter visitor at Rostherne. The largest numbers occur in winter; we have on several

occasions seen parties of from thirty to sixty or more birds in November, December, January and February. We have not met with it later than April, nor earlier than September on the return passage.

As a rule the Shoveler is *Spatula clypeata* (Linnaeus). a rather irregular spring and autumn bird of passage, but occasionally a fair number remain for the winter. This was particularly the case in the winter of 1913-1914, when varying numbers were usually present from the end of September onwards; on December 31st, 1913, there were more than two dozen together, and several of these were old drakes in excellent plumage.

The Pintail is little more than a straggler to Rostherne, as indeed it is to all the Cheshire inland waters, though common in the Dee and Mersey estuaries. Birds, however, which visit the water will sometimes stay for several weeks. In 1909 we noticed a drake on September 10th; it was then in eclipse; it attained full plumage about the middle of October and remained until well into December, when it was joined by another. There was a Pintail on the water, possibly the same bird, at the end of February, 1910. A drake, on March 12th, 1912, was consorting with a duck Mallard, but it was alone on the 26th; in April, and even so late as May 1st, there were a pair on the water, presumably the drake being the original bird.

The Pochard, like *Nyroca ferina ferina* (Linnaeus). most of the diving ducks, is both a bird of passage and winter visitor; its numbers vary considerably, and there is frequent movement from water to water, so that the absence of birds from the mere at any

time does not prove that they have left the district. Occasionally a bird will remain for most if not all of the summer, but we have no evidence that the Pochard has nested on Rostherne up to the present time ; at any time this species, which is extending its nesting area, may remain to breed. As a rule the flocks of Pochards are not so large as those of Tufted Ducks, but from time to time many hundreds may be seen together. In most years the majority of the birds depart in April, but they begin to return in July, and the number gradually increases until November. The largest numbers are usually to be seen when the smaller meres are ice-bound.

The Tufted Duck has not  
*Nyroca fuligula* (Linnaeus). only increased in numbers  
as a winter visitor to most  
British waters, but is rapidly extending its breeding range. On Rostherne it was, until about 1890, a winter visitor in varying numbers, and, as a rule, all birds left in March ; since then, however, there have been changes, which at first showed themselves in the lengthening of the spring stay, and the early return of the birds towards the end of summer. In 1906 one or two birds remained throughout the summer, but it was not until 1908 that the presence of young birds on the water suggested that one pair at least had nested in the vicinity. The parents, however, managed to keep the very young birds hidden, and we failed to find a nest, until at the beginning of September, 1913, we surprised a duck with five young in down on the open mere. This was a late brood, and it is possible that earlier broods had been brought off, for there were young birds, able to fly, on the water at the same time. From 1908 onwards there were usually two or three drakes, sometimes, but not always, accompanied by a duck, on the water in May and June ; it is more likely

that the ducks were sitting or tending young than that these drakes were unattached.

The immigrants begin to arrive in July or August, and by November there are often large numbers on the mere; early in December there is generally an increase, but, as with the Pochard, the largest numbers are to be seen on Rostherne when the birds are driven by frost from the shallower waters. The best feeding ground for all diving ducks is at the southern end of the mere, but a few may usually be seen diving near the bank alongside the Gale Bog and Harper's Bank wood.

The Scaup is an *Nyroca marila marila* (Linnaeus). infrequent visitor to Rostherne, as to other Cheshire fresh waters. We have only met with it on three occasions. On October 10th, 1908, Mr. Boyd saw a duck with the typical broad white mask. Towards the end of July, 1912, a drake spent a few days on the water, and at the end of November, in the same year, a female or immature bird was on the water.

The Goldeneye *Nyroca clangula clangula* (Linnaeus). is not so frequent a visitor to Rostherne as it is to some other Cheshire waters—Oakmere for instance—but it has occurred on passage in March, April, August, and October, and as a winter visitor in the months of November, December, January and February in various years. The birds, which are usually brown-headed and immature, seldom number more than two or three together, and solitary individuals are more frequently met with. Occasionally, however, an adult drake, accompanied by a few brown-headed birds, pays a passing visit, and in December, 1913, there were two fine drakes on the water at the same time. The Goldeneye is the least



sociable of the diving ducks, and it is exceedingly shy ; when feeding it keeps apart from the others, and when flushed speedily flies to the opposite end of the mere.

The Scoter is distinctly a salt-water duck, and we have only observed it at Rostherne in two years. In 1912 a single drake was first noticed on the water on August 13th, and remained there throughout the month. In 1913 there were extraordinary movements of Scoters in different parts of England and Wales, and black and pale-faced birds appeared on Rostherne and neighbouring waters from June 19th until the end of the first week in July. The largest number noticed on any one date was seven adult drakes on July 7th. In the same year, on December 7th, there were four pale-cheeked birds on Rostherne.

The Goosander is a winter visitor to Rostherne, but is not noticed every year. We observed it during the winters of 1902-3, 1905 (January), 1906-7 and 1912 (February). More brown-headed female or immature birds visit the Cheshire meres than adult drakes, but on several occasions there have been fine drakes on Rostherne. The birds are more on Tatton than on Rostherne during their visits, for probably it is easier to capture fish in the shallower waters, and on one or two occasions the visits to Rostherne have been on days on which Tatton was ice-bound.

The Smew is a rare visitor to the Cheshire meres, and it has only been noticed on Rostherne on one occasion. At the end of January, 1909, a duck, which we saw first on Tatton, appeared on

Rostherne when Tatton was frozen and consorted with a Goldeneye.

Although the *Phalacrocorax carbo carbo* (Linnaeus). Cormorant is a not infrequent visitor to some of the inland waters it has seldom been noticed on Rostherne. On September 17th, 1908, Mr. Boyd saw a couple of birds near the mouth of the stream, and shortly afterwards they followed fish into a strike net and were killed. They are in the possession of Mr. Egerton. On May 6th, 1914, there was a young bird on the water.

Towards the end of January, 1912, there was an extraordinary incursion of Shags to inland localities in Cheshire, Derbyshire, Yorkshire and Worcestershire.<sup>7</sup> The birds were not driven in by any local bad weather. Two immature birds reached Rostherne, and were either starved or frozen; we did not see either alive, but found their bodies in February and March.

The Great *Colymbus cristatus cristatus* Linnaeus. Crested Grebe is a common resident on Rostherne, and except when the waters are frozen there are always some birds to be seen. The numbers, however, fluctuate not only at different seasons but in different years; at times the birds appear to rear most of their young, but in other years very few are got off. Pairing and display is most noticeable in February and March, but occasionally pairs may be seen displaying in November and December. The eggs are usually laid in May, but occasionally in April, and young of various

<sup>7</sup> *British Birds.* V., 279, 307, 341.

ages may be seen throughout the summer ; we saw birds still feeding young on October 11th in 1908, but this was exceptionally late. In September and October there are often a large number of Grebes on the water, a score being not unusual, but in November and December the numbers fall off, probably many of the younger birds leaving. In January and February there is frequently an increase ; in the latter month and in March twenty, or even more, is not an unusual number. It is difficult to estimate the number of pairs which nest in the extensive reed-beds, but probably an average of half-a-dozen pairs is a low estimate. On April 1st, 1912, there were at least nine pairs.

The Black-

*Colymbus nigricollis nigricollis* (Brehm). necked Grebe

has occurred

on Rostherne. In February and March, 1912, two frequented the water for several weeks ; we noticed them first, when both were in winter dress, on February 18th, and one remained until March 31st, by which time it had attained almost complete nuptial dress. About a week after we missed the birds from Rostherne two were noticed on Marbury, and their plumages agreed with those of the two Rostherne birds when we last saw them. We watched them from time to time on Marbury but missed them after April 26th, by which time both were in full breeding plumage.

The Little Grebe

*Colymbus ruficollis ruficollis* Pallas. or Dabchick is

a common re-

sident, nesting like its larger relative in the reed-beds. It may be met with on all parts of the mere, but is perhaps most abundant at the southern end and it frequently feeds in Blackburn's Brook, where we have on

two or three occasions caught it by hand. On February 21st, 1902, we found one in the brook which had been choked when attempting to swallow a Bullhead, *Cottus gobio*; the spines on the gill-covers of the fish had been driven into the flesh at the sides of the bird's gape. This bird had been feeding on *Bythinia tentaculata* and beetle larvæ.

The Great Northern Diver *Gavia immer* (Brünnich). is an occasional winter visitor. There is a specimen at Tatton Hall which was shot at Rostherne "about forty years ago." It had been on the mere for some time. On January 8th, 1902, we saw one on the mere; it was feeding busily, and during one of its dives it was more than three minutes below the water. Another frequented Rostherne for over two weeks in December, 1911; we saw it first on the 10th and last on the 26th.

There was an *Haematopus ostralegus* Linnaeus. Oystercatcher at Rostherne on May 10th, 1914.

The Golden Plover *Charadrius apricarius* Linnaeus. is a common autumn and winter visitor to the fields in the neighbourhood of Rostherne, and on two or three occasions we have seen flocks or a few odd birds feeding with the Lapwings on the edge of the mere.

Lapwings, sometimes in *Vanellus vanellus* (Linnaeus). large numbers, feed in the fields which border the mere, where also many pairs nest, and frequently large numbers of birds may be seen feeding on the sandy margins or spits of sand at the mouths of the inflow brooks.

The Knot is a very occasional visitor on passage. We saw one on the edge of the mere on April 1st and 2nd, 1912.

The Dunlin appears less frequently on Rostherne than on some of the other meres, Marbury for instance, where it is not uncommon on passage. We have only seen it occasionally in May, when the birds were in breeding dress.

A few pairs of Common Sandpipers nest annually on or near the edge of the mere. In 1913 one nest was well in the covert at Wood Bongs and another was close to the water, within a few inches of a footpath, in the Gale Bog. Here the bird sat so tight that it was evidently overlooked, and eventually the eggs were accidentally trodden on. The immigrants arrive early in April, but towards the end of the month there are often more birds round the mere than actually remain to nest; passage birds halt to feed and rest.

The Green Sandpiper is a regular passage migrant and occasional winter visitor to the streams in the neighbourhood, but we have only occasionally seen the bird on the edge of the mere.

The Redshank is not uncommon as a visitor on passage, and is occurring more frequently now that its numbers are everywhere increasing and that it is extending its breeding area. We

have seen it most frequently during the spring passage, in March and April, but in 1913 there was one on the sand at the edge of the mere on July 27th.

At almost any season of the year Curlews may be heard and seen passing over the mere; the birds when in flight no doubt see the gleam of the water and are attracted in the hope of food. In spite of this fact, however, it is seldom that they alight or remain long when they do; they are, however, quick to see when anyone is about, and probably stay longer when the coast is clear. Probably the birds seen in March and April are passage migrants or residents going up to the Pennine hills, and those in August on the return passage, but it is hard to understand why individuals should pass in June and early July unless the moorland birds take occasional flights to the Mersey or Dee estuaries for food during the time that they are occupied with young.

The Common Snipe is a fairly abundant resident, nesting in some numbers in the Gale Bog and the withy beds. From early March onwards its drumming call is to be heard every evening and often during the day. In the autumn the numbers of the resident birds are increased by immigrants, and there is often a second and large invasion in November or December.

The Jack Snipe is a winter visitor, but is never in such large numbers as the Common Snipe; it frequents the same boggy spots.

The Woodcock is an autumn and winter visitor to the coverts which border on the mere, and it feeds in the brooks and ditches which run into the mere. It is possible that a pair may nest occasionally ; we have seen the bird so late as April.

The Black Tern *Hydrochelidon nigra nigra* (Linnaeus). is a fairly regular spring and autumn passage visitor to the Cheshire meres, but it has seldom been noticed at Rostherne. Mr. J. J. Cash saw two feeding over the water on August 1st, 1887, and in 1911 one, an adult bird, remained about the mere from April 20th to the 30th.

It is not always easy to identify the terns which *Sterna hirundo* Linnaeus. which appear on migration on our inland waters, but two which were flying over Rostherne on April 29th, 1908, but did not come near enough to be distinctly seen, were very likely Common Terns, for on the same date two or three out of five which were at Marbury Mere were certainly referable to this species, having well-marked black tips to their bills. A bird, however, which remained for two or three days at the end of July and beginning of August, 1912, was undoubtedly an Arctic Tern, as were two which we saw over the water on May 19th, 1913. These birds at times feed upon insects which fly above the water, stooping for them and picking them up after the manner of the Black Tern, but they also dive for something just below the surface and the quarry in this case is probably small fish.

The Lesser Tern is *Sterna minuta minuta* Linnaeus. not so frequently met with inland as the two larger birds, and one which was feeding over the mere on July 1st, 1913, was probably a wanderer from the estuary and not a passing migrant.

The Blackheaded Gull *Larus ridibundus* Linnaeus. has, within late years, become an almost regular Rostherne bird ; it is even present in small numbers during the nesting season, but there is no evidence that it has nested near the mere. Most if not all the birds which frequent the water in April and May are immature. On April 4th, 1910, we saw a pair of mature birds repeatedly stoop at a Heron which was standing on one of the mooring stumps ; their angry cries resembled those of breeding birds when attempting to drive intruders from the neighbourhood of the nest. After the breeding season is over young birds of the year appear with the adults and begin to roost nightly on the water ; as autumn advances the number of birds which come in every evening increases, and it reaches its maximum in the winter. From December to February there are usually several hundred gathered at dusk in a dense flock in the centre of the mere. The birds arrive from all directions, but the largest number come from the north and north-west ; those also which have been feeding on Tatton Mere during the day leave in a body in the afternoon and join the congregation at Rostherne. The birds straggle in for several hours in the afternoon ; they arrive singly or in large or small parties, often flying in chevron formation. On the afternoon of February 16th, 1914, we estimated that there were between 600 and 1,000 Blackheads on the water at about 4-30 p.m., and others were arriving. At the end of



December there are often numbers of birds on the water by 2 p.m. This habit of roosting on Rostherne appears to have originated within the last ten years, and less than twenty years ago the bird was a rather uncommon visitor. On April 17th, 1912, during a partial eclipse, a number of Blackheads came in and settled down as if to roost; they remained for a short time and then returned to their feeding grounds.

*Larus canus canus* Linnaeus. The Common Gull visits Rostherne in the winter, and a few roost with the Blackheads. We have not noticed the bird on the water later than the beginning of April, but it returns towards the end of July or beginning of August. In winter, when the mere is frozen, both Commons and Blackheads will roost on the ice.

*Larus argentatus argentatus* Lesser Black-backed Pontoppidan. Both the Herring and Gulls are frequent visitors from time to time and sometimes roost with the other gulls. The Herring Gull is, as a rule, a winter visitor only, but the Lesser Black-backed Gull frequently appears on migration in April and May and in autumn. Immature or non-breeding Lesser Black-backs may be met with in summer. These birds, whose backs are often very dark, appear to wander from mere to mere in search of food; we have noticed them often, singly, or in twos or threes, in June and July.

*Porzana porzana* (Linnaeus). Between February 16th and April 6th, 1912, we several times saw a small Crake, presumably a Spotted Crake, which had wintered on Rostherne. We never succeeded in getting

a really good view of the bird, but its size and appearance suggested this species. We saw it running through the reeds and swimming in the open beyond the bed.

*Rallus aquaticus* Linnaeus. The Water Rail is a not uncommon resident, but it is easier to see and flush in the winter than in the summer. On many occasions we have heard its loud scream, almost like that of a rabbit in distress, in the reed-beds. On one occasion we flushed the bird immediately after hearing the call. This call note is similar to but not so loud or prolonged as the spring "sharming."

*Gallinula chloropus chloropus* Linnaeus. The Moorhen is an abundant resident at Rostherne; it nests in the bushes at some distance from the mere, as well as in the vegetation close to the water.

*Fulica atra atra* Linnaeus. The Coot is exceedingly abundant on the mere and most of the nests are built in the reeds, where these already bulky structures are added to if the water rises. It is difficult to say if any immigrant Coots reach Rostherne, but the numbers undoubtedly rise in winter; this, however, may be due to the wanderings of birds from mere to mere. Almost anytime in winter from 80 to 100 Coots may be counted on the water or the banks, where the birds frequently feed. We saw a mob of 188 on January 29th, 1909.

#### REPTILIA AND BATRACHIA.

Only one of our Reptiles, the Ringed Snake, has aquatic habits, and it has not been found, so far as we know, at Rostherne.

|                                   |                         |
|-----------------------------------|-------------------------|
|                                   | Four Batrachians—the    |
| <i>Rana temporaria</i> Linnaeus.  | Common Frog, Com-       |
| <i>Bufo bufo</i> (Linnaeus).      | mon Toad, Crested and   |
| <i>Molge cristata</i> (Laurenti). | Common Newts—occur      |
| <i>Molge vulgaris</i> (Linnaeus). | in the immediate neigh- |
|                                   | bourhood of Rostherne,  |

but we have no recollection of seeing any of them, nor their spawn, in the mere itself.

#### PISCES.

The difficulty of netting so deep a water as Rostherne, and the fact that it is comparatively little fished, accounts for the scarcity of information about its fish fauna.

Certain fishes, the Perch especially, are more easily tempted by a bait than others, and most fishermen who visit Rostherne try either for Perch or Pike. The Perch in this mere are fine, deep fish, and often bite freely. It is not unusual to take a dozen or more and for the fish to average  $\frac{3}{4}$  lb., or even a pound; the largest we have taken personally weighed just under  $1\frac{1}{2}$  lbs. The Rostherne Perch feed freely on *Asellus*, and we have found these crustaceans alive in the stomachs of fish some hours after capture. We have also, in July, August and September, on several occasions, found larval Perch in the stomachs of fish that we had caught. In June we have found the Carp-louse, *Argulus foliaceus*, on fish. We once found a living leech in the stomach of a Perch.

|                               |                             |
|-------------------------------|-----------------------------|
|                               | The Bullhead or Miller's    |
| <i>Cottus gobio</i> Linnaeus. | Thumb occurs in Blackburn's |
|                               | Brook, but not often in the |

mere. Coward found one dead at some distance from any brook.

The Pike, a favourite sporting fish at Rostherne, sometimes attains considerable size ; we have, however, no record of a heavier weight than 15½ lbs. When walking along the edge of the mere in March and April numbers of spawning Pike will be seen darting through the reeds into deeper water ; indeed, at all seasons it is not uncommon to disturb small Pike from the edge of the mere, but the larger fish do not come so close inshore. Smelts, we are told, have been disgorged by Pike which had just been captured. The stomachs of five that we took on February 28th, 1914, contained very little food ; all, including females, 6 lbs. and 7 lbs. 4 oz. in weight, had been feeding on *Asellus aquaticus*, and the larvae of aquatic beetles.

The Eel is a fairly abundant fish in the mere, and often attains a large size. The largest we know of was over 5 lbs. in weight.

Mr. J. Millington, the game-keeper at Rostherne, has no knowledge of the Tench in the mere, but on May 9th, 1910, Coward saw a dead fish near the bank which he believes was a Tench. It was about 2 ft. long, and had very small scales. He was unaware, at that time, that the fish was unknown in the mere, and did not examine it carefully.

The Minnow occurs in Blackburn's Brook, but is not common.

The Bream occurs at Rostherne, but is seldom fished for. A Bream weighing 5 lbs. 7 oz. has been caught in the mere.

The Roach is fairly  
*Leuciscus rutilus* (Linnaeus.) plentiful in the water.

On July 12th, 1913, we saw a large fish come to the surface and struggle. We picked it up and it died immediately. Mr. James Johnstone, who kindly examined it for us, found that it was not diseased, but its gills were coated with a deposit of phytoplankton, in which he could recognise some species of *Ceratium*, *Stephanodiscus* and *Anabaena*. The mere at that time was "breaking," and the fish had, without doubt, been suffocated by the extraordinary abundance of these plants; it had been unable to breathe on account of the "water-bloom." Our tow-nettings for that date show that these three constituents of the plankton, and *Asterionella*, were greatly in excess of their normal numbers. Roach of rather over 2 lbs. are sometimes taken in the mere.

In a water in which large  
*Salmo trutta* Linnaeus. Pike occur there are not likely to be many Trout, although introductions have been attempted, and the river Birkin, into which Blackburn's Brook flows, is a good Trout stream. On February 16th, 1895, when the mere was frozen, we saw a fair-sized Brown Trout embedded in the ice, and this is not the only evidence that these fish occasionally elude the Pike for some time. When we were trolling for Pike on February 28th, 1914, Mr. T. Hadfield caught a Loch Leven, a very silvery fish, which scaled 2 lbs. 14½ oz. No Loch Levens have been released in the mere itself, and the dates at which these fish have been turned down by the Bollin Angling Society do not appear to warrant a Trout of this size; on the other hand, one may have escaped from a stock-pond in Tatton Park and have found its way into the mere. If so, this fish must have been in the mere for two or three

years, and have grown considerably during that period. The food in its stomach largely consisted of *Asellus aquaticus* and the larvae of Caddis-flies in their cases.

The Smelt or Sparling is the most interesting fish in Rostherne. As already explained,\* Day's statement that the Smelts were introduced by a Mr. Egerton<sup>9</sup> is refuted by our knowledge of their presence in the mere at an earlier date than he evidently refers to. It seems to be possible that the anadromous Smelts were land-locked at some remote time, and succeeded in maintaining their position. A rather ingenious theory of monastic introduction has been suggested by Mr. H. Hulme. As he points out (*in lit*), a portion of the Tatton estate was handed over to the monks of Norton, who established themselves at Mobberley circa 1200, and these Mobberley monks possessed nets and boats and had rights of fishing in Tatton Mere. The monks of Norton Priory would be familiar with the estuarine Smelts and may have stocked Tatton and Rostherne, or, finding that Tatton was unsuitable for the fish, have established them successfully in Rostherne. There is, however, no documentary evidence referring to actual stocking of either waters. The only Rostherne Smelts which we have seen personally were a number which we cut out of the ice in February, 1895, and two we picked up dead on April 4th, 1912.<sup>10</sup>

The earliest known reference to the Rostherne Smelts is in Richard Brookes's "Art of Angling," published in 1740. He calls the fish "the Sprat or Sparling," confus-

\* "Vertebrate Fauna of Cheshire," II., 151, and Coward, T. A., *Manchester Memoirs*, lvi. (1912), No. 15.

<sup>9</sup> "British Fishes," II., 123.

<sup>10</sup> Coward, T. A., "The Smelt in Rostherne Mere," *Manchester Memoirs*, lvi. (1912), 15.

ing it with the young of the Herring, but it is evident that he means the Smelt.

“ In *Rotherston*, or *Rostern-Meer* in *Cheshire*, there are *Sprats* taken annually for ten Days about *Easter*, which are not to be distinguish'd in any manner from *Sea-Sprats*, being of the same Colour, Shape and Taste. Likewise at the same time that they are taken in the *Meer*, they are also caught in the River *Mersey* below *Warrington-Bridge*, where the Tide brings up the Salt-Water, which Place is about seven or eight Miles from the *Meer*. But the most remarkable Circumstance relating to the Affair is this, That tho' there is a Rivulet runs thro' the *Meer* into the River *Mersey*, and though there are several *Weirs* between the Lake and the River, yet no *Sprats* have been ever caught or seen between these two Places.” The remainder of the article is speculation as to the origin of the Smelts in the mere.

So far as we can discover, Richard Brookes's statement that the Smelt does not occur in the Bollin has never been refuted, although at a later date Benjamin Martin, when describing the rivers of Lancashire,<sup>11</sup> mentions “the Bollen, a small River rising in *Cheshire*, which is also augmented with other Rivulets, and principally abounds with Sparklings or Smelts.”

This work, which is undoubtedly a compilation, is not reliable on other points, and possibly Martin copied from Brookes, but misunderstood him.

The Brook Lamprey occurs *Lampetra planeri* (Bloch). in Blackburn's Brook, but we do not know that it actually enters the mere. Large numbers were running up out of the Birkin on April 21st and 22nd, 1912.

<sup>11</sup> “The Natural History of England,” 2 vols. 1763. II., 254





## X. Carbon: its molecular structure and mode of oxidation.

By MAURICE COPISAROW, B.Sc.

(Read February 24th, 1914. Received for publication April 23rd, 1914.)

As it often happens in the sphere of ideas the conception of the mode of oxidation of carbon has passed through several stages of development, gradually expanding with the accumulation of observations and experimental evidence.

In the last quarter of a century the *reduction theory* of Lang (*Zeit. Phys. Chemie*, 1888, 2, 62) has been replaced by that of *gradual oxidation* by Baker (*Phil. Trans.*, 1888, A 179, 571) and Dixon (*J.C.S.*, 1896, 69, 774; 1899, 75, 630), which in its turn is likely to be substituted by the *theory of complexes* propounded by Rhead and Wheeler (*J.C.S.*, 1910, 97, 2181; 1911, 99, 1140; 1913, 103, 461).

After careful consideration we find that none of these theories is either absolutely wrong or a complete representation of the actual reaction. Each of them represents a more or less partial view of the phenomenon, the true explanation of which will require the correlation of these theories with one another and all the facts known up to now considered from a logical standpoint. In making this attempt we shall postulate the following three fundamental assumptions as a basis.

I. A carbon molecule contains a large number of atoms. (This is suggested by its high volatilisation point.)

May 22nd, 1914.

II. A carbon atom is always tetravalent. (Gomberg's experiments on tri-phenyl methyl and Nef's on the polymethylene compounds do not necessarily imply the non-tetravalency of a carbon atom.)

III. Carbon exists in three allotropic modifications (several new modifications suggested by Brodie, Berthelot, Luzzi and others have been proved by Moissan and Le Chatelier to be either compounds or solutions and mixtures of carbon with some other element).

As we have to deal with the combination of carbon with oxygen, it is obvious that the knowledge of the mechanism of such a combination must be of essential importance. It seems to me that there are two, and only two possible hypotheses, which can explain the process : —

1. The carbon molecule disintegrates at the first instant into single atoms, which combine subsequently with oxygen.

2. Oxygen combines at the first instant with the atoms inside the carbon molecule, next follows a disruption of the complex and the formation of the known oxides.

Which of these two hypotheses is the correct one? Can we reasonably suppose that by the mere presence of oxygen, which has not yet reacted chemically, the carbon molecule falls to atoms, which would imply the volatility of carbon at a temperature below red heat?

I think that the first hypothesis is, at least, improbable. Now what can be said about the second?

(a) It is in complete agreement with the most recent experimental evidence.

(b) It is quite logical.

(c) It explains facts.

(d) It is the only one left.

Accepting the second hypothesis we are immediately confronted by a multitude of complexes, requiring in their turn a clear conception of a carbon molecule.

What is a carbon molecule?

Is it a formless mass of atoms in a state of chaotic disorder, or is it organised similar to the assumed structure of carbon compounds?

Our assumption will be—organisation.

Now, if carbon is always tetravalent, what is the constitutional, or, as Butlerow calls it, structural formula for a carbon molecule? Not much work has been done up to the present in this direction.

Victor Meyer (*Berichte*, 1871, 4, 801; *Liebig's An.*, 1875, 180, 195), from results obtained on moist oxidation of carbon, assumes a carbon molecule to be polyatomic.

Kekulé (*Zeit. für angew. Chemie*, 1899, 950) regards a carbon molecule as consisting of 12 atoms.

Barlow and Pope (*J.C.S.*, 1906, 89, 1742) suggested the possibilities of a tetrahedron and tri-naphthalene configuration for a carbon molecule.

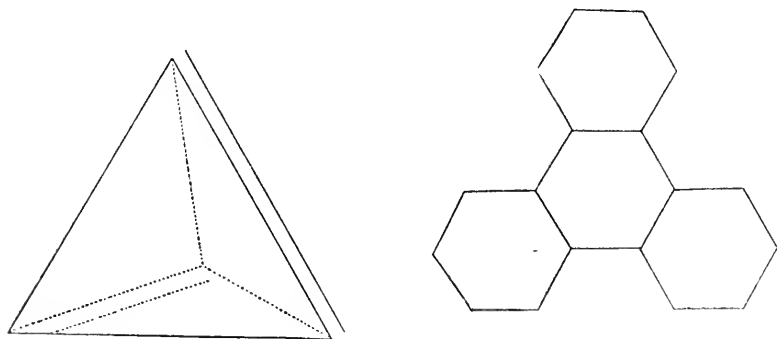
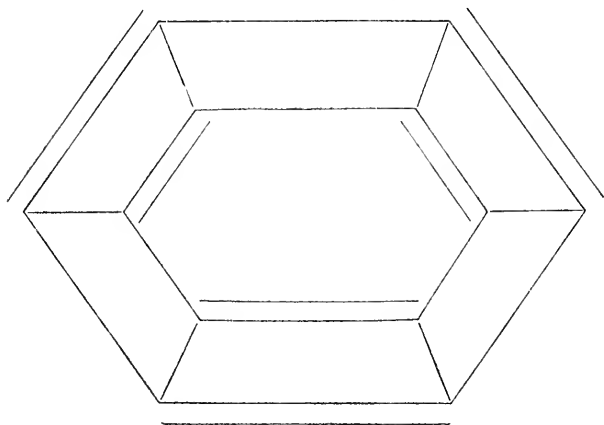

Fig. 1.

Dewar (*Chem. News*, 1908, 97, 16) proposed the formula



*Fig. 2.*

basing his view on the oxidation of amorphous carbon to mellitic acid— $C_6(COOH)_6$ . Redgrove and Thomlinson (*Chem. News*, 1908, **98**, 37) suggested certain modifications of Dewar's formula.

Aschan (*Chem. Zcit.*, 1909, **33**, 561), criticising Dewar's suggestion, put forward the formula

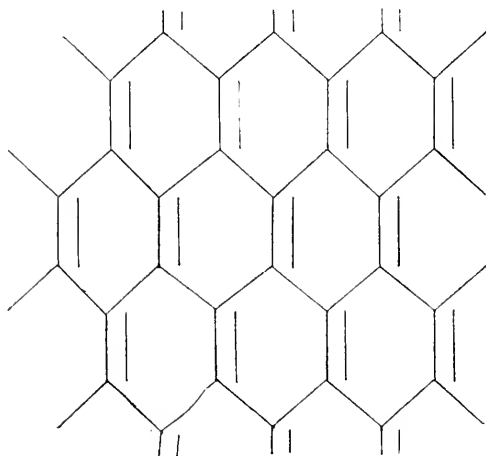

*Fig. 3.*

Dimroth and Kerkovius (*Liebig's An.*, 1913, 399, 120) thought a carbon molecule to consist of pentagons as well as hexagons.

Bragg (*Proc. R. S.* 1913, A610), studying crystalline structures by means of a  $X$ -ray spectrometer, advanced a three-dimensional configuration for a molecule of diamond.

H. Meyer (*Monatsh.*, 1914, 35, 163) discussing the the carbon "molecule," puts stress on the difficulty, if not the futility of trying to define the chemical entity of the three forms of carbon.

Here we see that the number of suggestions varies more with the number of investigators than the number of allotropic modifications of carbon.

Now keeping in mind the proposed fundamental assumptions, let us follow the possibilities for such a representation ( $n$  being the number of atoms in a carbon molecule).

The first class is noted by the *power of free rotation* of the units (single atoms or groups) constituting the carbon molecule. (See *Fig. 4*.)

The second class is noted by the *partial rigidity* of the molecule, owing to the two single bonds linking some units. (See *Fig. 5*.)

The third class is noted by *complete rigidity* of the molecule. (See *Fig. 6*.)

Here we have before us the striking fact that any possible formula for carbon will fall into one of these three classes. These three distinct classes are remarkable from the fact that they would account for the three modifications of carbon, and suggest the possible formulæ for amorphous carbon, graphite and diamond.

We may hope that the careful study of the comparative reactivity, theory of strain, refraction and other

physical properties of these forms will enable us to assign to each modification its constitutional formula.

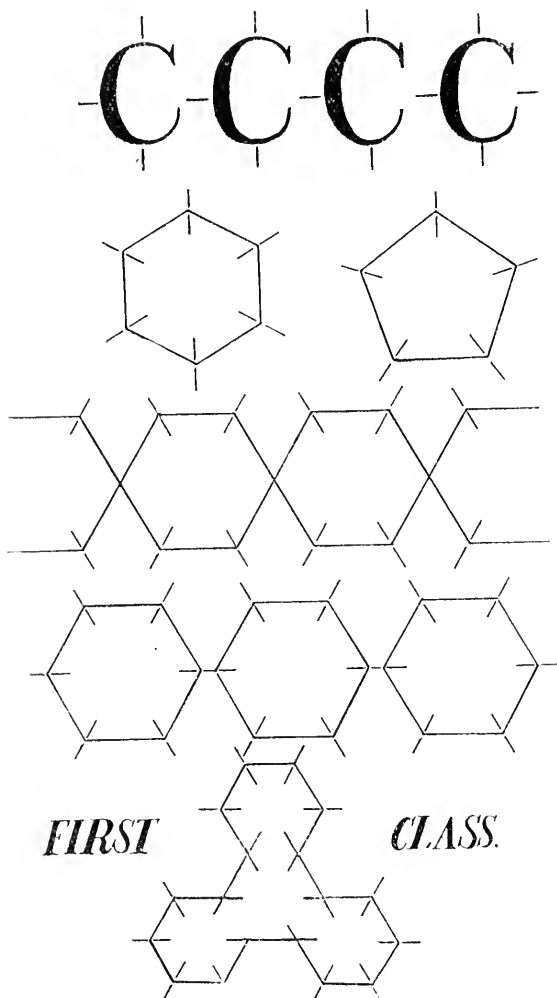
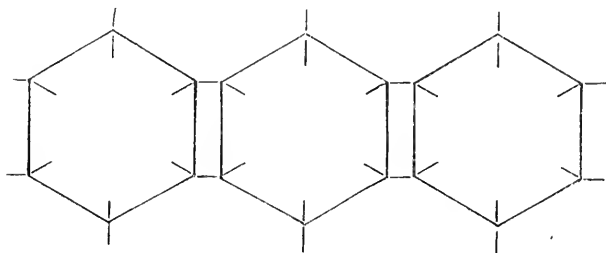

*Fig. 4.*

The following considerations may serve as a pioneer attempt in this direction.

The calorimetric measurements of the heat of complete combustion of carbon per gram-atom give the following numbers (Nernst):—

|                  |     |             |
|------------------|-----|-------------|
| Amorphous carbon | ... | 97.650 cal. |
| Graphite         | ..  | 94.810 „    |
| Diamond          | ... | 94.310 „    |



### *SECOND CLASS.*

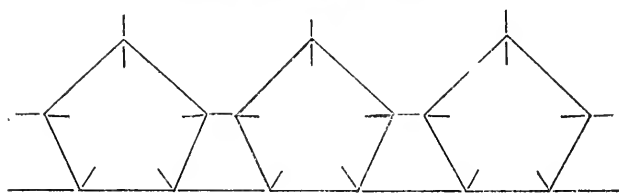

*Fig. 5.*

These calorimetric measurements indicate the sum-total of the energy liberated during the formation and degradation of the complexes, plus that of the oxidation of CO to CO<sub>2</sub>.

The whole process can be represented in the following manner:—

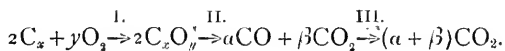

These three stages can be conveniently represented by the equation:—

$$K = a + b + c.$$

Where  $K$  represents calories,  $a$  the heat of formation of the complexes,  $b$  the heat of their disruption,  $c$  the heat of oxidation of CO to CO<sub>2</sub>.

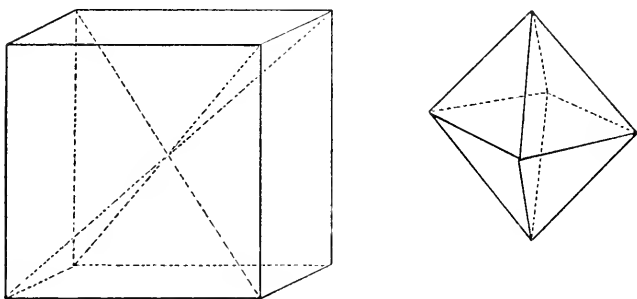

### THIRD CLASS

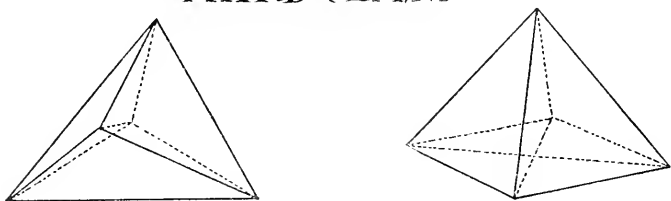

*Fig. 6.*

It seems at first sight possible to use this formula as a means of comparison and determination of the class to which each form of carbon belongs, but, on more careful consideration this fails, owing to the fact that each member of the equation varies with the particular modification and experimental conditions.

Taking equal weights of amorphous carbon, graphite and diamond, and subjecting them to complete com-



bustion, we find that the amount of heat evolved is different for each form of carbon, although the number of atoms taken and the number of CO<sub>2</sub> molecules formed is identical.

Looking for the cause of this dissimilarity, we are driven to attribute it to the varying stability of the molecules in the three cases, which must depend upon the mode of linkage of the units inside the molecule.

Returning to our table of classification, we expect that the least stability will be shown by molecules whose units have the power of free rotation; the maximum stability will be found in the molecule all the constituent units of which are in a state of rigidity, the intermediate case being a molecule having some units which are rigid and some free.

Now, considering the fact that the greater the stability the smaller will be the evolution of heat on complete combustion (compare the case of phosphorus), and correlating this with the calorimetric measurements quoted above, we find that

Amorphous carbon is represented by Class I., where  
*none* of the units are *rigid*;

Graphite, Class II., *some* units are *rigid*; and

Diamond, Class III., *all* units are *rigid*.

Although these deductions are in good agreement with Barlow and Pope's, Aschan's and Bragg's views, still they cannot be taken as quite conclusive, as the calorimetric measurements, which serve as a basis for these conclusions, not only differ in magnitude with every experimenter, but unfortunately contradict one another.

(Favre and Silberman, *A. ch.* [3] 35, 357, 1852.

Berthelot and Petit, *A. ch.* [6] 18, 80, 1889.

Mixter, *Amer. J. of Science* [4] 19, 440, 1905.

Roth and Wallasch, *Berichte* 46, 896, 1913.)

Clearing up the ground so far as we can as regards the structure of carbon molecules, we shall proceed with the consideration of the complexes of the general formula  $C_xO_y$ .

In the process of gradual oxidation  $C_xO_y$  may be regarded as a physico-chemical variable, depending upon the allotropic form and extent of oxidation,  $x$  being always equal to the number of atoms in a carbon molecule, unless sub-complexes are also formed, when the number of atoms in a carbon molecule will be a multiple of  $x$ .

Although the number of intermediate theoretically possible complexes is very large, still judging by the actual ultimate products the final complexes may be :

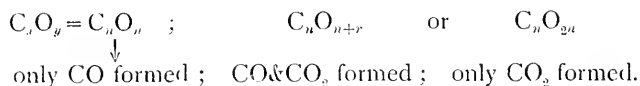

where  $n$  is the number of atoms in a carbon molecule, and  $r$  the number of carbon atoms forming CO<sub>2</sub> molecules.

Therefore the general formula for the final complex will be :

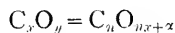

where  $\alpha$  is a variable depending upon temperature, pressure or concentration of oxygen as well as the particular form of carbon, and varying between zero and  $n$ .

#### GENERALISATIONS.

1. Polyatomic molecules combining with one another and giving finally single molecules, must either disintegrate before the reaction (under the influence of T, P, etc.), or form a complex or complexes, stable or unstable, as the case may be.

11. Polyatomic molecules of elements may be represented by constitutional formulæ in a way similar to the molecules of compounds.

In conclusion I wish to express my great indebtedness to Prof. H. B. Dixon, F.R.S., for his sympathetic interest and kind criticism, and to Dr. H. F. Coward for several suggestive discussions in connection with this paper.

Chemical Department,  
The University, Manchester,  
*February, 1914.*



## XI. Note on the Intrinsic Field of a Magnet.

By J. R. ASHWORTH, D.Sc.

*(Communicated by Dr. George Hickling, F.G.S.)*

*(Received and read May 12th, 1914.)*

The researches of P. Curie have shewn that the magnetic properties of the ferro-magnetic bodies above their critical temperatures, the intensity of magnetisation then being very feeble, may be represented by an equation which is exactly analogous to the gas equation, in which the gas pressure is replaced by the strength of the applied field, the gas density by the intensity of magnetisation, and the gas constant by a constant which, in the magnetic equation, depends upon the nature of the magnetic material.

Curie further showed that a ferro-magnetic body in passing through the critical temperature from the state of strong magnetism into the state when the gas equation applies behaves in general like a fluid in passing from the liquid to the gaseous state.

In order to develop this line of thought I have suggested the application of an equation to ferro-magnetism which is analogous to Van der Waals' equation to fluids.<sup>1</sup>

Van der Waals extends the gas equation by introducing a mutual attraction between the molecules equivalent to

<sup>1</sup> "The Temperature Coefficient of the Ferro-magnetic Metals." *Nature*, Aug. 25th, 1910. "The Temperature Coefficients of the Ferro-magnetic elements in corresponding states." *Phil. Mag.*, Jan., 1912, p. 36.

a pressure and by putting a limit to the density. In ferro-magnetism it is generally admitted that there is a mutual attraction of the molecular magnets, and that there is a limit to the intensity of magnetisation, and these are the counterparts of the leading ideas in Van der Waals' theory.

This view of ferro-magnetism requires that there should be an intrinsic field analogous to the intrinsic or molecular pressure in a liquid, and, further, if the quantity analogous to the gas constant  $R$  is to be treated as *constant over the whole range of temperature* as in the fluid equation, then this intrinsic field must be very large, and in this respect is analogous to the large intrinsic pressure in a liquid.

In a recent paper (*Phil. Mag.*, February, 1914)<sup>2</sup> I have shewn that the ferro-magnetic equation in its main features is in agreement with experimental facts, and it is easy to deduce from the data there given that the intrinsic field must be of the order of several millions of gausses, which it is needless to say is far greater than any magnetic field yet produced in air.

Prof. P. Weiss has developed a kinetic theory of magnetism based on Curie's views, and has found it necessary to introduce into his theory a molecular field which must be of the same large order. He claims to have established the existence of this field by showing that the gradual increase of the specific heats of the ferro-magnetic bodies up to their critical temperatures and the rapid change at that point to the normal value is exactly explained by the energy absorbed in the diminution and final destruction of such a field due to thermal agitation of the molecular magnets.<sup>3</sup> But so far the magnitude of

<sup>2</sup> "The Anhyseretic Properties of Iron and Nickel." *Phil. Mag.*, Feb., 1914.

<sup>3</sup> P. Weiss and P. N. Beck, *J. de Phys.*, 1908, (4), t. vii., p. 249.

this intrinsic field cannot be readily explained according to recognised laws. If such a field exists its lines of force, if uniform, apparently do not extend to the outside of the magnet, and the fact that a very small reverse applied force easily demagnetises a magnet is a difficulty in accepting the idea of an intrinsic field of large magnitude.

It is therefore desirable to look for additional evidence either for or against the existence of such a field and the following experiment supplies further information on the question.

Let two iron wires of the same structure dip into the limbs of a U-tube filled with a suitable electrolyte. If one of the limbs be placed between the poles of an electro-magnet an electro-motive force is established between the wires of such kind that the magnetised wire acts to the unmagnetised like copper to zinc in a simple cell. This can be explained by considering the iron ions as tending to pass into solution, but where there is a magnetic field the magnetic ions are held back and thus more positively charged iron ions pass from the unmagnetised than from the magnetised electrode into the solution, and hence the current is from the unmagnetised to the magnetised electrode through the solution.

The experiment arranged in this way has been carried out in recent years by Hurmuzescu<sup>4</sup> in fields up to 7,000 gauss, and by R. Paillot<sup>5</sup> in fields up to 30,000 gauss with concordant results. The latter finds a maximum of electro-motive force developed in a field of 25,000 gauss.

Assuming that the electro-motive force arises from the magnetisation of the iron the experiment can be submitted to calculation by applying the hypothesis that the electrical work is the equivalent of the magnetic work.

<sup>4</sup> *J. de Phys.*, (3), t. iv., p. 118. 1895.

<sup>5</sup> *Comptes Rendus*, 131, pp. 1194-5. 1900.

Treating the intrinsic field within the iron as the unknown quantity its magnitude can then be calculated, and the result is found to be of the order of the intrinsic field required by the ferro-magnetic equation analogous to Van der Waals' equation, or as required by Prof. P. Weiss in his investigations.<sup>6</sup>

Although the experiment is thus in favour of an intrinsic field of some millions of gausses, the derivation of this enormous field is still unexplained, and its magnitude needs further confirmation.

There are other experimental results which might be brought to bear on the question. For example, there is a remarkable and rapid change in the thermo-electromotive force of both iron and nickel at or about the critical temperature of these metals. Also the temperature coefficient of electrical resistance of iron and nickel is abnormally large compared to other pure metals. These facts are probably connected with the magnetic qualities of iron and nickel, and, if so, should give some clue to the magnitude of the intrinsic field when submitted to quantitative investigation.

Sir J. A. Ewing's Presidential address to Section G at the British Association Meeting at York in 1906, on the similarity of crystalline polar forces to molecular magnetic forces, is suggestive in connection with these newer views of a very large intrinsic field in a magnet.

<sup>6</sup> *Vide* Appendix.

---



APPENDIX.

1. Van der Waals' equation in terms of pressure ( $p$ ), density ( $\rho$ ), and absolute temperature ( $T$ ) may be written

$$(p + a\rho^2)\left(\frac{1}{\rho} - \frac{1}{\rho_0}\right) = RT.$$

where  $\frac{1}{\rho_0}$  is put for Van der Waals'  $b$ .

The analogous ferro-magnetic equation is

$$\left(H + f(I)\right)\left(\frac{1}{I} - \frac{1}{I_0}\right) = R' T.$$

Here  $f(I)$  represents the intrinsic field. If  $R'$  is an unique constant, both below and above the critical temperature, and equal to the reciprocal of Curie's constant, then it may be shewn that the intrinsic field in iron is of the order  $10^7$  gausscs.

2. The magnetic work done in transferring an element of volume ( $dv$ ) of magnetic material from a place where the intensity of magnetisation is zero to a place where it becomes  $I$  is

$$\frac{1}{2} \frac{I^2}{k} dv.$$

The corresponding electrical work is

$$Edq$$

where  $E$  is the potential difference, and  $dq$  the quantity of electricity transferred.

Let  $z$  be the electrochemical equivalent and  $\delta$  the density of the magnetic substance, then

$$dv = \frac{z}{\delta} dq.$$

If the magnetisation arises from the intrinsic field ( $H_i$ ), then

$$\frac{I}{k} = H_i$$

and the magnetic work may be written

$$\frac{1}{2}IH_i \frac{Z}{\delta} dq.$$

Equating the magnetic to the electric work, we have

$$\begin{aligned} \frac{1}{2}IH_i \frac{Z}{\delta} dq &= Edq \\ \therefore H_i &= \frac{2E}{Z} \frac{\delta}{l} = \frac{2E}{Z} \frac{1}{\sigma} \end{aligned}$$

$\sigma$  being the specific magnetisation.

3. The magnitude of the intrinsic field is obtained as follows:—

*Iron.*

$$H_i = \frac{2E}{Z\sigma}$$

$$E = 0.3 \times 10^8 \text{ c.g.s. units (vide R. Paillot loc. cit.).}$$

$$Z = 3 \times 10^{-3} \text{ c.g.s. units for divalent iron.}$$

$$\sigma = 212.$$

$$\begin{aligned} H_i &= \frac{2 \times 0.3 \times 10^8}{3 \times 10^{-3} \times 212} \\ &= 9.4 \times 10^6 \end{aligned}$$

According to Prof. Weiss<sup>7</sup> the maximum intrinsic field of iron is  $6.5 \times 10^6$  gauss.

*Nickel.*

$$E = 0.01 \times 10^8 (?) \text{ (vide Hurmuzescu loc. cit.).}$$

$$Z = 3.08 \times 10^{-3} \text{ c.g.s. units for divalent nickel.}$$

$$\sigma = 56.$$

$$\begin{aligned} H_i &= \frac{2 \times 10^5}{3.08 \times 10^{-3} \times 56} \\ &= 1.2 \times 10^6. \end{aligned}$$

According to Prof. Weiss<sup>7</sup> the maximum intrinsic field of nickel is  $6.4 \times 10^6$  gauss.

The values for  $E$  and  $\sigma$  given above are maxima, but the E.M.F. of magnetisation of nickel is not precisely stated, but is said to be of the order given above.

<sup>7</sup> P. Weiss and P. N. Beck, *J. de Phys.*, 1908, (4), t. vii., p. 249.

**XII. The Specification of Stress. Part IV. The Elastic Solution : The Elastic Stress relations and conditions of Stability : Struts, ties and test-pieces.**

By R. F. GWYTHER, M.A.

*(Received and read, March 10th, 1914.)*

In Part III. of this series of papers I developed a mode of treatment of stresses in a medium, and of the relation between stresses and strain in an isotropic solid. The method can readily be adapted to suit a crystalline medium, but in the present Part I propose to complete the solution for an isotropic elastic solid. I shall also obtain a simple form of the six relations between the elastic stresses. This form is intended to be applicable to the consideration of the fulfilment of surface-traction conditions. Although conditions of this character are not considered in this Part, an illustration of the employment of the stress relations is given by considering a special case.

The results arrived at are of a general dynamical character, but under statical conditions they depend on Laplace's equation only, and are more completely definite than in the case of motion.

*The formal Elastic Solution.*

It is proposed to complete the solution of the conditions arrived at in Part III., where the displacement and the elements of strain and stress in an elastic solid were given in cartesian, in cylindrical and in polar co-

*September 19th, 1914.*

ordinates in terms of  $F_1$ ,  $\mu_1$ ,  $\mu_2$  and  $\mu_3$ , and where it was stipulated that

$$\frac{\partial^2 \mu_1}{\partial x^2} + \frac{\partial^2 \mu_2}{\partial y^2} + \frac{\partial^2 \mu_3}{\partial z^2} = 0 \quad . \quad . \quad . \quad (1).$$

The relations between the four functions essential for elastic conditions are

$$\rho(\ddot{F} + \ddot{\mu}_1) = (m + n) \nabla^2 F + n \nabla^2 \mu_1$$

with two analogous relations . . . . . (2).

Omitting some stages in the investigation, the solution in cartesian takes the form

$$\begin{aligned} F = n \left\{ \phi + \frac{1}{2} \left( x \frac{\partial \phi_1}{\partial x} + y \frac{\partial \phi_2}{\partial y} + z \frac{\partial \phi_3}{\partial z} \right) \right\} \\ + g \left\{ \psi + \frac{1}{2} \left( x \frac{\partial \psi}{\partial x} + y \frac{\partial \psi}{\partial y} + z \frac{\partial \psi}{\partial z} \right) \right\}, \\ \mu_1 = (m + n) \left\{ \phi_1 - \frac{1}{2} \left( x \frac{\partial \phi_1}{\partial x} + y \frac{\partial \phi_2}{\partial y} + z \frac{\partial \phi_3}{\partial z} \right) \right\} \\ + (2m + 2n - g) \left\{ \psi - \frac{1}{2} \left( x \frac{\partial \psi}{\partial x} + y \frac{\partial \psi}{\partial y} + z \frac{\partial \psi}{\partial z} \right) \right\}, \end{aligned}$$

with two similar expressions for  $\mu_2$  and  $\mu_3$  . . . . . (3).

The condition arising from (1) becomes

$$x \frac{\partial}{\partial x} \nabla^2 \phi_1 + y \frac{\partial}{\partial y} \nabla^2 \phi_2 + z \frac{\partial}{\partial z} \nabla^2 \phi_3 = 0 \quad . \quad . \quad . \quad (4).$$

In order that (2) may be satisfied, it is requisite that

$$\begin{aligned} \rho \ddot{\phi} &= (m + n) \nabla^2 \phi, \\ \rho \ddot{\phi}_1 &= n \nabla^2 \phi_1, \end{aligned}$$

with two similar conditions for  $\phi_2$  and  $\phi_3$  . . . . . (5), and also that

$$\rho \ddot{\psi} = g \nabla^2 \psi$$

and

$$\left( x \frac{\partial}{\partial x} + y \frac{\partial}{\partial y} + z \frac{\partial}{\partial z} \right) \nabla^2 \psi = 0.$$

From these we may now construct expressions for the displacement, and for the elements of strain and stress,

applicable for cases of rest or of motion, and including the case of stability of equilibrium. The expressions for the elements of stress found in this manner are complete solutions, but it is thought convenient to express separately and in as simple a manner as possible the relations between the elements of stress and the elastic constants after eliminating any reference to displacement or strain.

*The Elastic Stress relations.*

The relations are readily obtained by the method of this series of papers, but they can also be verified from the fundamental stress equations and the six geometrical elastic stress relations, and by this means a test of accuracy of working may be attained.

I state in the first instance the typical relations in cartesian coordinates in the form in which I obtained them.

These typical forms are as follows :

$$\begin{aligned} \rho \left\{ \ddot{P} - \frac{m(m-n)}{(3m-n)(m+n)} (\ddot{P} + \ddot{Q} + \ddot{R}) \right\} \\ = n \left\{ \nabla^2 P + \frac{2m}{3m-n} \frac{\partial^2}{\partial x^2} (P + Q + R) \right\}, \\ \rho \ddot{S} = n \left\{ \nabla^2 S + \frac{2m}{3m-n} \frac{\partial^2}{\partial y \partial z} (P + Q + R) \right\} . . . . (6). \end{aligned}$$

Altering the form of these relations in order to obtain a further simplification, I write them as follows :

$$\begin{aligned} \rho \ddot{P} - n \nabla^2 P = \frac{m(m-n)}{3m-n} \nabla^2 (P + Q + R) + \frac{2mn}{3m-n} \frac{\partial^2}{\partial x^2} (P + Q + R), \\ \rho \ddot{S} - n \nabla^2 S = \frac{2mn}{3m-n} \frac{\partial^2}{\partial y \partial z} (P + Q + R) . . . . (7). \end{aligned}$$

These are the stress relations the correctness of which can be otherwise verified. It will be noticed that the invariant  $P + Q + R$  appears in every term on the right-hand side.

To obtain these results in the simplest form, I write

$$P + Q + R = \frac{3m - n}{n} \nabla^2 \psi \quad . . . . . (8),$$

so that

$$\begin{aligned} \rho \ddot{P} - n \nabla^2 P &= \frac{m(m - n)}{n} \nabla^4 \psi + 2m \frac{\partial^2}{\partial x^2} \nabla^2 \psi \\ \rho \ddot{S} - n \nabla^2 S &= 2m \frac{\partial^2}{\partial y \partial z} \nabla^2 \psi \quad . . . . . (9). \end{aligned}$$

By adding the three equations, of which the first equation in (9) is the type, we get

$$\nabla^2 \left\{ \rho \ddot{\psi} - (m + n) \nabla^2 \psi \right\} = 0, \quad . . . . . (10),$$

which gives a description of  $\psi$ , and which is in agreement with the necessary condition that

$$\rho(\ddot{P} + \ddot{Q} + \ddot{R}) - (m + n) \nabla^2 (P + Q + R) = 0.$$

It will be noted that  $\psi$  is *described* but not *defined*, it will contain an arbitrary function  $V$  such that  $\nabla^2 V = 0$ .

Returning to equations (9) and omitting some steps in the reduction, we find as a simplification or solution,

$$\begin{aligned} P &= P_0 + \frac{m - n}{n} \nabla^2 \psi + 2 \frac{\partial^2}{\partial x^2} \psi, \\ S &= S_0 \quad \quad \quad + 2 \frac{\partial^2}{\partial y \partial z} \psi, \end{aligned}$$

with the analogous equations. In these equations we have with (8) and (10)

$$\rho \ddot{P}_0 - n \nabla^2 P_0 = 0, \quad \rho S_0 - n \nabla^2 S_0 = 0. \quad . . . (11).$$

The correctness of the results in (11) may be verified by substitution for  $P$ , or  $S$ , in (9).

The six relations given in (7), (9), and (11) constitute the relations between the elements of stress which I proposed to find. In them no direct reference is made to displacement or to strain.

In the previous Part of this paper, I extended the forms of expression so as to include cylindrical and

spherical polar coordinates, and thus have prepared the way for the introduction of the corresponding stress relations. In cartesian coordinates it was sufficient to give two typical relations, each giving the form of three others, but this will not suffice in the other cases, and it will be necessary to find the relations in full.

[In the paper as submitted a statement of results was given here. I have decided to reserve this statement for amplification in view of its importance and to insert an outline of the method of verification in its place.

In cartesian, cylindrical polar, or spherical polar coordinates we have three dynamical equations given in (1), (28), or (37) of Part III.<sup>1</sup>

For each system of coordinates we have six relations between the elements of stress derived from the six geometrical relations between the strains.

In Part II.<sup>2</sup> combined with Part I.<sup>3</sup> I have shewn that the six relations between the elements of stress may be obtained by writing in the expressions referred to in the pages named from Part I.,

$$P - \frac{m-n}{3m-n}(P+Q+R) \text{ for } 2n\theta_1, \text{ etc.,}$$

and  $S$  for  $2n\Psi_1$ , etc.

The six dynamical relations between stresses only may be obtained by eliminating in every way the strains from the original dynamical equations and simplifying the results by making use of the six geometrical relations.

In the case of cartesian coordinates the results are readily obtained as in (7). The other cases are more laborious. The present paper is now limited to the case

<sup>1</sup> *Manchester Memoirs*, Vol. lviii. (1914), No. 5, pages 6, 16, or 19.

<sup>2</sup> *Manchester Memoirs*, Vol. lvii. (1913), No. 5, page 2.

<sup>3</sup> *Manchester Memoirs*, Vol. lvi. (1912), No. 10, pages 5 and 9 and Table A.

of cartesian coordinates, but it will indicate the importance of the series of stress relations for any system of coordinates.]

The expressions for the elements of stress are not complete solutions of any problem, but they are proposed as convenient forms to 'aid in the solution of any specific question—for example, when surface-tractions are defined.

*The Solution of the Statical Stress relations.*

Returning to the set of equations (7), put  $\dot{P} = 0$ , etc.

Then we have

$$\begin{aligned} \nabla^2(P + Q + R) &= 0 \\ \nabla^2 P &= -\frac{2m}{3m - n} \frac{\hat{c}^2}{\hat{c}x^2}(P + Q + R) \quad \dots \quad (12), \end{aligned}$$

etc.,

and we obtain

$$P = P_0 - \frac{m}{3m - n} x \frac{\hat{c}}{\hat{c}x}(P + Q + R)$$

etc.,

in which  $\nabla^2 P_0 = 0 \quad \dots \quad (13).$

These equations constitute the formal solution in the case of equilibrium of the six elastic relations, but they are still subject to three conditions which will affect the arbitrary functions, namely, that

$$\frac{\partial P}{\partial x} + \frac{\partial U}{\partial y} + \frac{\partial T}{\partial z} = 0, \text{ etc.}$$

*The Conditions for Stability of equilibrium.*

It is sufficient to consider one of the elements of stress, say  $P$ .

In the general case,  $P$  must satisfy

$$\left(\rho \frac{\hat{c}^2}{\hat{c}t^2} - (m + n) \nabla^2\right) \left(\rho \frac{\hat{c}^2}{\hat{c}t^2} - n \nabla^2\right) P = 0,$$



and therefore will have the solution

$$P = P_{m+n} + P_n,$$

where

$$\left( \rho \frac{\partial^2}{\partial t^2} - \eta \nabla^2 \right) P_n = 0$$

indicates the notation.

In the state of equilibrium

$$\nabla^4 \bar{P} = 0$$

and there will be the solution in the form

$$\bar{P} = P_0 + \alpha \frac{\partial Q_0}{\partial x},$$

or in some similar form.

To examine the stability of the state of equilibrium in regard to some displacement, we introduce time-terms into  $\bar{P}$  without altering its form; that is, without departing from that configuration in equilibrium of which we propose to examine the stability.

We will call the new element of stress  $\bar{P}'$ . Then we shall have two cases according as  $\nabla^4 \bar{P}'$  is or is not identically null.

If  $\nabla^4 \bar{P}'$  is not null, then it will be necessary that

$$\bar{P}' = \bar{P}'_{m+n} + \bar{P}'_n$$

as in the general case.

But if  $\nabla^4 \bar{P}' = 0$ , then  $\bar{P}'$  must satisfy the equation

$$\frac{\partial^2}{\partial t^2} \left( \rho \frac{\partial^2}{\partial t^2} - (m + 2n) \nabla^2 \right) \bar{P}' = 0,$$

or

$$\bar{P}' = U + Vt + \bar{P}'_{m+2n} \dots \dots \dots (14),$$

when  $U$  and  $V$  are any functions of  $x, y$  and  $z$ .

*Struts, ties and test-pieces.*

In order to indicate how, in special connection with the method proposed, the solution of the stress relations

under statical conditions is to be employed, without making use of surface-traction conditions which have not as yet been introduced, it is necessary to make some general assumption on which to base an illustration.

St. Venant has discussed the case when  $P=0, = U0, Q=0$ , and has given the general method on which surface-conditions may be treated.

I select the case of a strut connecting parts of a structure, considered to be straight, or, at any rate, to have a definite axial direction, which I shall take to be the axis of  $z$ . The object of a strut is to convey a state of stress from one part of a structure to another. I shall suppose as describing the conditions of the special case to be considered that all stresses are independent of  $z$ , so that the stresses are communicated without change from section to section of the strut.

The conditions to be made use of are (13) and the fundamental static equations

$$\frac{\partial P}{\partial x} + \frac{\partial U}{\partial y} = 0; \quad \frac{\partial U}{\partial x} + \frac{\partial Q}{\partial y} = 0; \quad \frac{\partial T}{\partial x} + \frac{\partial S}{\partial y} = 0.$$

The relations obtained from (13) become

$$P = P_o - \frac{m}{3m - n} x \frac{\partial}{\partial x} (P + Q + R),$$

$$Q = Q_o - \frac{m}{3m - n} y \frac{\partial}{\partial y} (P + Q + R),$$

$$R = R_o,$$

$$S = S_o,$$

$$T = T_o,$$

$$U = U_o - \frac{m}{3m - n} x \frac{\partial}{\partial y} (P + Q + R),$$

or 
$$= U_o - \frac{m}{3m - n} y \frac{\partial}{\partial x} (P + Q + R) \dots \dots \dots (15),$$

with 
$$\left(\frac{\partial^2}{\partial x^2} + \frac{\partial^2}{\partial y^2}\right)(P + Q + R) = 0.$$

The sole condition in regard to  $S$  and  $T$  is that they shall be conjugate functions.

In regard to  $P_o$ ,  $Q_o$  and  $U_o$  we obtain on elimination of  $P + Q + R$

$$\begin{aligned} \frac{\partial^2}{\partial x \partial y} (P_o - Q_o) &= 0, \\ \frac{\partial^2 P_o}{\partial x^4} + 2 \frac{\partial^2 U_o}{\partial x \partial y} + \frac{\partial^2 Q_o}{\partial y^2} &= 0 \quad . \quad . \quad . \quad . \quad (16). \end{aligned}$$





### XIII. Faunal Survey of Rostherne.

#### III. Preliminary List of Lepidoptera found round the Mere.

By A. W. BOYD, M.A., F.E.S.

(*Read March 24th, 1914. Received for publication April 7th, 1914.*)

The following list of Lepidoptera is the result of more or less casual collecting by day during the last three years round Rostherne Mere, which I have visited fairly often, principally to look for birds.

As I did not wish to disturb the game in the coverts, I only collected by night on two occasions, once visiting the shallows in spring and once at midsummer, when sugar was tried; consequently the list of Nocturæ is a singularly poor one, and I have no record of many species which are certain to be abundant; comparatively more attention has therefore been paid to the Microlepidoptera. Little collecting seems to have been done at Rostherne before; three records in Day's Lepidoptera of Cheshire are all that I can discover, though some of the old records for Bowdon, made by Mr. R. S. Edleston, may possibly refer to Rostherne.

In all I can record 148 species, but hope to add many during the coming season.

The Gale Bog is the best collecting ground, and a big willow-bed at the other end of the mere contains some species in plenty; the game coverts contain remarkably few.

It is interesting to note the presence of several species which, in Lancashire and Cheshire, are usually found on the "mosses" or in similar country, such as *Acronycta*

*June 19th, 1914.*

*leporina*, *Lygris testata*, *Geometra papilionaria*, *Acidalia straminata* (var. *circellata*), *Pædisca solandriana*, *Argyresthia retinella*, *Elachista cerussella*, etc.

*Platyptilia bertrami*, *Hedya ocellana*, *Elachista cerussella*, *Elachista apicipunctella*, *Laverna raschkiella*, *Lithocolletis viminiella* and *Lithocolletis stettinensis* are new to the Cheshire list, and a few other species have seldom been recorded before for Cheshire.

As is always the case in this district, a tendency towards melanism is to be seen in a number of species, such as *Phigalia pedaria* (var. *monacharia*), *Hybernia marginaria* (var. *fuscata*), *Cidaria truncata*, *Malenydris didymata*, *Hydriomena impluviata* (ab. *infuscata*), *Diurnea fagella*, *Hedya ocellana*, etc.

I must acknowledge my thanks to Mr. W. Mansbridge and Mr. J. H. Durrant for kind help in identification of the Microlepidoptera.

The nomenclature followed is that of R. South in the Moths of the British Isles (1907 and 1908) for the macrolepidoptera, and in his synonymic list of British Lepidoptera (1884) for the Microlepidoptera.

*Pieris napi*, L.

Fairly common ; the only butterfly I have seen.

*Smerinthus populi*, L.

A batch of ova on a poplar-trunk below the Church ; at present in pupa. One emerged 16.3.14.

*Chærocampa elpenor*, L.

Recorded by Mr. J. Thorpe in Day's Lepidoptera of Cheshire.

*Orgyia antiqua*, L.

*Dicranura vinula*, L.

One in the large willow-bed, 25.5.13, freshly emerged above its pupa on a willow-stump.

*Porthesia similis*, Fues.

Abundant both as larva and imago.

*Drepana falcataria*, L.

One on Harper's Bank, 8.5.12.

*Cilix glaucata*, Scop.

18.5.12 and 4.6.13.

*Nola cucullatella*, L.

A few, July 1911 and 1912.

*Acronycta leporina*, L., var. *bradyporina*, Tr.

One in the Gale Bog, 9.7.10.

*Acronycta psi*, L.

1.7.13.

*Noctua augur*, Fb.

Several at sugar in the Gale Bog, 1.7.13.

*Noctua baja*, Fb. }

*Noctua brunnea*, Fb. }

Larvæ in the neighbouring covert of Yarwood-heath in 1911.

*Noctua rubi*, View.

Several in the Gale Bog, 1.7.13.

*Mamestra thalassina*, Rott.

In the Mere Covert, 7.6.13.

*Eumichtis protea*, Bork.

One, 27.9.08.

*Diloba cæruleocephala*, L.

A larva on the Gale Bog hedge, 7.6.13; imago emerged in the autumn.

*Apamea gemina*, Hb.

Two, 1.7.13.

*Miana strigilis*, Clerck.

1.7.13.

*Phlogophora meticulosa*, L.

1.7.13.

*Ochria ochracea*, Hb.

Recorded by Mr. J. Thorpe in Day's Lepidoptera of Cheshire.

*Leucania impura*, Hb.

8.7.12, flying in the Gale Bog.

*Petitampha arcuosa*, Hw.

Recorded by Mr. J. Thorpe in Day's Lepidoptera of Cheshire.

*Pachnobia rubricosa*, Fb.

A few at sallows in the Gale Bog, 31.3.13.

*Tæniocampa gothica*, L.

Common at sallows in the Gale Bog, 31.3.13.

*Tæniocampa stabilis*, View.

A few at sallows in the Gale Bog, 31.3.13.

*Tæniocampa incerta*, Hufn.

A few at sallows in the Gale Bog, 31.3.13.

*Tæniocampa gracilis*, Fb.

A fair number at sallows in the Gale Bog, 31.3.13.

It also occurs commonly at the neighbouring covert of Yarwoodheath.

*Eupsilia satellitia*, L.

One taken by Mr. T. A. Coward in the boat-house in the autumn of 1912.

*Plusia gamma*, L.

1.7.13.

*Abrostola triplasia*, L.

1.7.13.

*Zanclognatha grisealis*, Hb.

18.6.11.

*Hypena proboscidalis*, L.

1.7.13.

*Geometra papilionaria*, L.

A pair in the Mere Covert, 18.7.13.

The ♂ was of a yellow form. It was not bleached and had evidently not long emerged.



*Acidalia straminata*, Tr., var. *circellata*, Gn.

3.7.13. This is a most interesting record. Until recently this local Northern variety was thought to be a separate species, but it has been shown to be a variety of *A. straminata*. With the exception of one Yorkshire locality (Skipwith), this variety is practically unknown now; it has long been extinct in its old Lancashire locality at Chat Moss, but one was taken in Delamere in 1903. Mr. R. S. Edleston recorded it from Bowdon many years ago; it seems possible that this old record actually refers to Rostherne, which is only  $2\frac{1}{2}$  miles from Bowdon. The typical insect is really unknown in this district—only one specimen ever having been taken in Lancashire and Cheshire. (Delamere, 1901.)

*Acidalia bisetata*, Hufn.

Two in July, 1912.

*Lygris testata*, L.

Two in the Gale Bog, 14.7.12.

*Cidaria truncata*, Hufn.

In the Harper's Bank wood, 7.6.13; a dark form.

*Coremia unidentaria*, Hw.

Not uncommon.

*Coremia designata*, Rott.

Not uncommon.

*Amæbe viridaria*, Fb.

Fairly common.

*Malenydris didymata*, L.

Fairly common; the specimens are dark.

*Oporabia dilutata*, Bork.

18.10.08.

*Xanthorhoë montanata*, Bork.

Very common.

*Xanthorhoë sociata*, Bork.

Common.

*Mesoleuca albicillata*, L.

One in the Harper's Bank wood, 4.7.11. I have taken another (at no great distance) in Tatton Park.

*Mesoleuca bicolorata*, Hufn.

In July, 1912 and 1913.

*Perizoma alchemillata*, L.

Abundant along the big willow-bed, 10.7.10; one 4.7.11.

*Perizoma albulata*, Schiff.

Common where the yellow-rattle grows, 1913.

*Hydriomena impluviata*, Hb.

Common, (abundant in 1911); ab. *infuscata* is the commonest form, though a few of the typical form occur.

*Eupithecia vulgata*, Hw.

18.6.11 and 14.7.12.

*Eupithecia satyrata*, Hb.

One, 15.6.13.

*Eupithecia exiguata*, Hb.

One, 4.6.13.

*Lomaspilis marginata*, L.

Common among shallows, especially in the Gale Bog.

*Cabera pusaria*, L.

Abundant.

*Cabera exanthemata*, Sc.

Common.

*Opisthograptis luteolata*, L.

Common.

*Hybernia leucophæaria*, Schiff.

Sparingly in the Wood Bongs and the Mere Covert on oak-trunks, 1911, 1912 and 1913 (as early as Jan. 19). It is very plentiful in Tatton Park.

*Hybernia marginaria*, Bork., var. *fuscata*, Harrison.

The males I have seen have all been of this dark variety.

*Hybernia defoliaria*, Clerck.

Larvæ fairly common.

*Anisopteryx æscularia*, Schiff.

23.3.08, flying under an alder.

*Phigalia pedaria*, Fb.

A few in the Mere Covert, Feb. 1911.

*Phigalia pedaria*, Fb., var. *monacharia*, Staud.

11.3.11. This black form occurs also in Tatton Park and Dunham Park.

*Boarmia gemmaria*, Brahm.

8.7.11.

*Lozogramma petraria*, Hb.

Common among bracken.

*Hepialus humuli*, L.

Fairly common in a meadow by the brook, 1912.

*Hepialus hecta* (*hectus*, L.).

Common in the Mere Covert and on Harper's Bank, 1912 and 1913; feeds on bracken.

*Scoparia ambigualis*, Tr.

Plentiful.

*Scopula lutealis*, Hb.

Fairly common, 1911 and 1912.

*Scopula olivalis*, Schiff.

22.7.13.

*Hydrocampa nymphæata*, L.

Common among water-plants.

*Platyptilia bertrami*, Rössl.

1.7.13, in the Gale Bog ; not previously recorded  
from Cheshire.

*Mimaseoptilus bipunctidactyla*, Hw.

12.7.12, in the Gale Bog ; feeds on scabious.

*Crambus pratellus*, L.

Two in June, 1913.

*Crambus tristellus*, Fb.

9.7.11.

*Crambus culmellus*, L.

Abundant.

*Crambus hortuellus*, Hb.

1.7.10.

*Tortrix xylosteana*, L.

9.7.11 and 14.7.12

*Tortrix ribeana*, Hb.

Common.

*Tortrix unifasciana*, Dup.

Abundant.

*Tortrix costana*, Fb.

A fair number in 1912 and 1913, especially in  
the Gale Bog.

*Tortrix viridana*, L.

Abundant.

*Tortrix ministrana*, L.

27.5.11.

*Peronea variegana*, Schiff.

A few.

*Teras contaminana*, Hb.

Abundant in autumn.

*Dictyopteryx læflingiana*, L.

2.7.11 and 3.7.13,

*Dictyopteryx forskaleana*, L.

9.7.11.

*Penthina corticana*, Hb.

Several, 18.6.11.

*Penthina variegana*, Hb.

4.7.11.

*Hedya* (*Tmetocera*) *ocellana*, Fb.

8.7.12. New to the Cheshire list. A melanic form (identified by Mr. J. H. Durrant).

*Hedya dealbana*, Fröl.

A few in July, 1911 and 1912.

*Spilonota trimaculana*, Hw.

Two in the Gale Bog, 4.7.12.

*Aspis udmanniana*, L.

23.7.12.

*Sericoris lacunana*, Dup.

Most abundant.

*Cnephasia musculana*, Hb.

12.5.12.

*Sciaphila subjectana*, Gn.

Abundant.

*Sciaphila hydridana*, Hb.

7.7.11.

*Bactra lanceolana*, Hb.

Very common in the Gale Bog among rushes.

*Phoxopteryx diminutana*, Hw.

15.6.13; feeds on willow.

*Phoxopteryx lundana*, Fb.

Two, 12.5.12.

*Grapholitha subocellana*, Don.

Plentiful in the big willow-bed, June, 1913; feeds on willow.

*Grapholitha penkleriana*, Fisch.

3.7.13.

*Hypermezia cruciana*, L.

23.7.11, and two in July, 1912; feeds on willow.

*Pædisca bilunana*, Hw.

18.6.11.

*Pædisca corticana*, Hb.

9.7.11.

*Pædisca solandriana*, L.

Several in the Gale Bog, July and August, 1911.

*Ephippiphora pflugiana*, Hw.

Two in the Gale Bog, June, 1913.

*Catoptria ulicetana*, Hw.

May, 1913; common among gorse.

*Catoptria cana*, Hw.

27.7.13.

*Symæthis oxyacanthella*, L.

Common.

*Eupœcilia maculosana*, Hw.

11 and 12.5.12, on Harper's Bank.

*Conchylis straminea*, Hw.

8.7.12.

*Diurnea figella*, Fb.

Abundant on the more isolated oak-trunks.

Among a large number I have only seen one light form.

*Scardia corticella*, Curt.

On trunks in the Gale Bog in July; the larva feeds on fungus growing on trees.

*Micropteryx subpurpurella*, Hw.

3.5.13. In the Harper's Bank wood.

*Nemophora schwarziella*, Zell.

Fairly common in May and June.

*Adelu viridella*, L.

May, 1912.

*Swammerdamia pyrella*, Vill.

8.5.12.

*Plutella cruciferarum*, Zell.

Common, especially in the big willow-bed

*Phibalocera quercana*, Fb.

4.7.11, etc. Not uncommon.

*Teleia proximella*, Hb.

27.5.11, etc. A few annually.

*Teleia luculella*, Hb.

One on an oak-trunk, 30.6.12.

*Dasycera sulphurella*, Fb.

Many pupæ in a rotten alder-stump in May,  
1913; from these I bred a good number.

Also on Harper's Bank, 11.5.12.

*Endrosis fenestrella*, Scop.

13.5.13.

*Argyresthia nitidella*, Fb.

Very common.

*Argyresthia spiniella*, Zell.

28.7.11.

*Argyresthia retinella*, Zell.

24.6.12 and 3.7.13.

*Argyresthia gædartella*, L.

Fairly common, especially in the Gale Bog.

*Argyresthia brochella*, Hb.

Fairly common, especially in the Gale Bog.

*Ornix avellanella*, Sta. (non Hb.).

27.5.13. Identified by Mr. J. H. Durrant.

*Coleophora cæspititiella*, Zell.

June, 1912; among rushes.

*Coleophora fuscadinella*, Zell.

8.7.12.

*Coleophora lutipennella*, Zell.

20.7.12.

*Bactrachedra præangusta*, Hw.

Abundant on poplar-trunks below the Church,  
23.7.12; also near poplars in the Mere  
Covert, 1911.

*Laverna raschkiella*, Zell.

27.5.13. New to the Cheshire list. Identified by  
Mr. J. H. Durrant.

*Chrysoclysta aurifrontella*, Hb.

1.7.10.

*Elachista apicipunctella*, Stn.

New to Cheshire. 15.6.13.

*Elachista albifrontella*, Hb.

15.6.13.

*Elachista cerussella*, Hb.

Common in June, 1913, in the big willow-bed ;  
recorded from the Lancashire mosses by  
C. S. Gregson—not previously recorded from  
Cheshire.

*Elachista rufocinerea*, Hw.

Common.

*Elachista argentella*, Clerck.

15.6.13 and 3.7.13.

*Lithocolletis quercifoliella*, Fisch.

19.5.13.

*Lithocolletis viminiella*, Stn.

Not previously recorded for Cheshire. Fairly  
common in the willow-bed in May and  
June, 1913. (Iden. J. H. D.)

*Lithocolletis alnifoliella*, Hb.

Abundant in May on alder-trunks on Harper's  
Bank.

*Lithocolletis stettinensis*, Nic.

23.7.12. New to the Cheshire list. (Iden. J. H. D.)

*Cemiostoma laburnella*, Heyd.

On a laburnam in the Mere Covert.

*Nepticula argentipedella*, Zell.

24.5.13. Mr. J. H. Durrant identified this. He  
writes:—"Somewhat worn, but probably  
rightly determined."



#### **XIV. Juvenile Flowering in *Eucalyptus globulus*.**

By Professor F. E. WEISS, D.Sc., F.L.S.

(Read October 7th, 1913. Received for publication, September 12th, 1914.)

It is a well known fact that the young plants of the Blue Gum (*Eucalyptus globulus*) have very different foliage from that which is characteristic of the mature plants. In the former the leaves are arranged in pairs opposite each other, they possess no leaf stalks and their blade is horizontally expanded. The foliage is covered with a waxy bloom which gives it the peculiar greyish tinge. This immature foliage persists for many years. Under cultivation in the greenhouse, particularly when pruned back, plants may grow for fifteen or more years without showing any trace of the characteristic foliage of the mature plant. When this latter stage has been reached the leaves are found to be inserted alternately on the branches; they are pendant, owing to the possession of a distinct and slender leaf stalk, and the leaf is sickle-shaped instead of possessing the bilateral symmetry of the juvenile foliage. The mature foliage, owing to the pendant position of the leaves, is undoubtedly better adapted to resist drought and intense insolation than is the foliage of the juvenile plant, which probably grows for a considerable time in the shade and shelter of taller trees. Such differences in the foliage of immature and mature plants are not at all uncommon and among Australian plants belonging to a widely different natural order the Acacias may be cited as another example,

October 31st, 1914.

though the juvenile foliage in these plants is generally restricted to the seedling stage of the plant.<sup>1</sup> A more strictly analogous though less striking difference can be seen in the case of the immature and mature foliage of the Holm Oak (*Quercus Ilex*).

The flowering of *Eucalyptus globulus* is usually restricted to branches possessing the mature foliage and does not normally commence until the tree has assumed considerable dimensions. I have however had under observation two interesting cases of young trees, which flowered at an early age and while still clothed with the immature foliage. The first of the two plants, growing in a six-inch pot, was cut down after its first year's growth to the height of about two feet. One of the lateral buds then became a leader, and growing some two feet in length produced, towards the end of the second summer, a number of flower buds in the axils of five pairs of leaves of perfectly normal type, typical of the young plants, *i.e.*, broad and rounded at their base and devoid of any trace of leaf stalk. Most of these flowers expanded next summer, *i.e.*, in the third year of the tree's growth. They were well formed and produced ripe pollen; but though several flowers were fertilised and showed some further development of the ovary, no ripe seeds were produced.

Several plants which had been growing for many years in the same greenhouse and which had attained much greater dimensions showed neither any sign of mature foliage nor flower buds. Even the oldest which has occasionally produced branches with pendant leaves has never formed flower buds.

It may therefore be that the severe interference with

<sup>1</sup> Pritzel has, however, described one species of *Acacia* (*Acacia insolita*) which, in its mature condition, possesses both pinnate leaves and phyllodes. Engler's *Botan. Jahrb.*, XXXV., 1904, p. 311.

the growth of the plant, which took place by the shortening of its main stem, may have had some influence in the production of the flowers. This is however by no means always the case, though it has occurred in one other specimen which had been similarly treated.

The production of flowers on such immature plants is of some biological interest, and Cockayne has recently drawn attention to the occurrence of numerous cases of such precocity observed in New Zealand, while Diels<sup>2</sup> in 1906 gave us a fuller account of the same phenomenon.

In this latter account he deals with several interesting occurrences in the genus *Eucalyptus*, which he interprets as cases of juvenile flowering, or more properly of the retention of the juvenile foliage in mature plants.

According to Diels, *Eucalyptus pulverulenta* and *Eucalyptus melanophloia* seem to be juvenile flowering forms of *Eucalyptus Stuartiana* and *E. crebra*, just as von Müller<sup>3</sup> had considered that *Eucalyptus Risdoni* from Tasmania was only a form of *Eucalyptus amygdalina*, which had retained the immature foliage in the cooler climate of Tasmania.

I understand, however, from Mr. L. Rodway, of Tasmania, that neither Müller's nor Diel's suggestions regarding the relationship of these species of *Eucalyptus* are accepted by Australian and Tasmanian botanists familiar with these plants in the field.

Mr. Rodway tells me that the reason why in many instances *Eucalyptus Risdoni* retains its juvenile foliage is that it often grows on the poorest and driest mudstone. Wherever *Eucalyptus Risdoni* establishes itself on land not quite so poor it develops into the form referred by

<sup>2</sup> Diels, L. "Jugendformen und Blütenreife im Pflanzenreich." Berlin, 1906.

<sup>3</sup> Von Müller, F. "Eucalyptographia," V. 1880.

Bentham to *var. elata* with long falcate, petioled leaves, with the venation always more netted than in any form of *Eucalyptus amygdalina*. *E. Risdoni* appears to be very variable and apparently flowers are borne both on specimens with large opposite and connate leaves as well as on others with narrow stalked leaves similar to those of *E. amygdalina*, but with a different venation.

*Eucalyptus globulus*, under certain methods of cultivation as described above, may also produce flowers on young plants with immature foliage.

#### EXPLANATION OF PLATES.

*Plate I.*—General view of upper portion of young plant of *Eucalyptus globulus*, showing flowers at four of the nodes of the shoot which has replaced the main axis after the latter had been cut down to about two feet above the soil.

*Plate II.*—Enlarged view showing the leaves of immature type subtending the flowers.

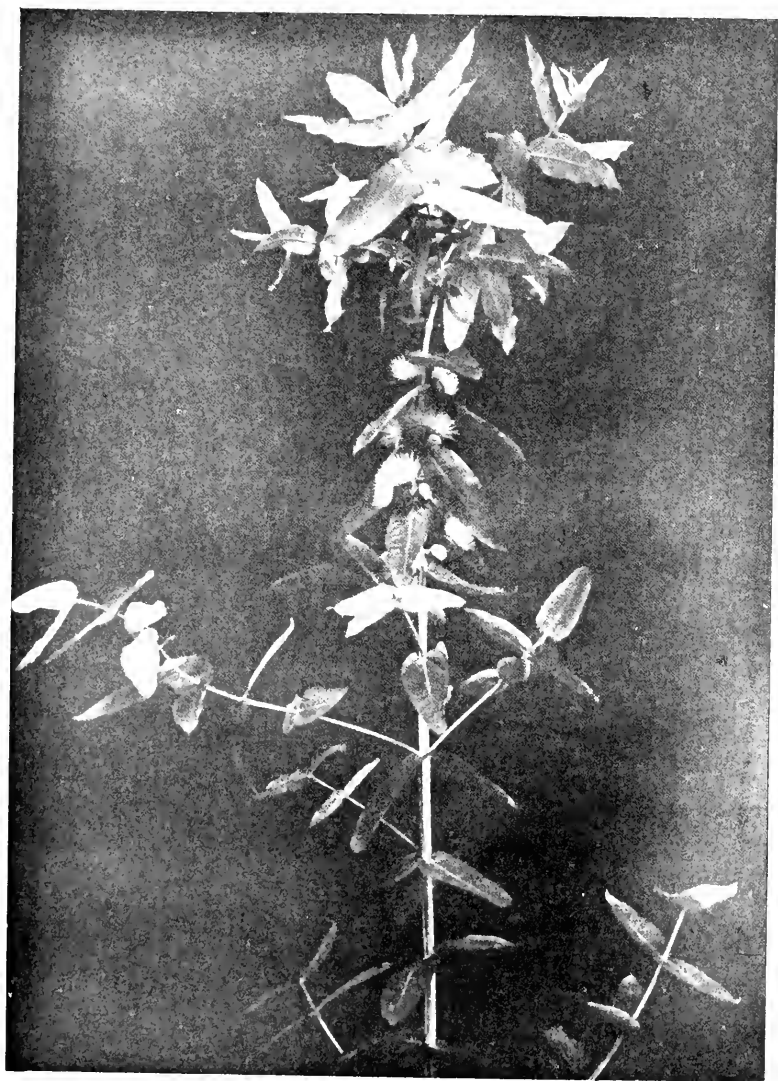



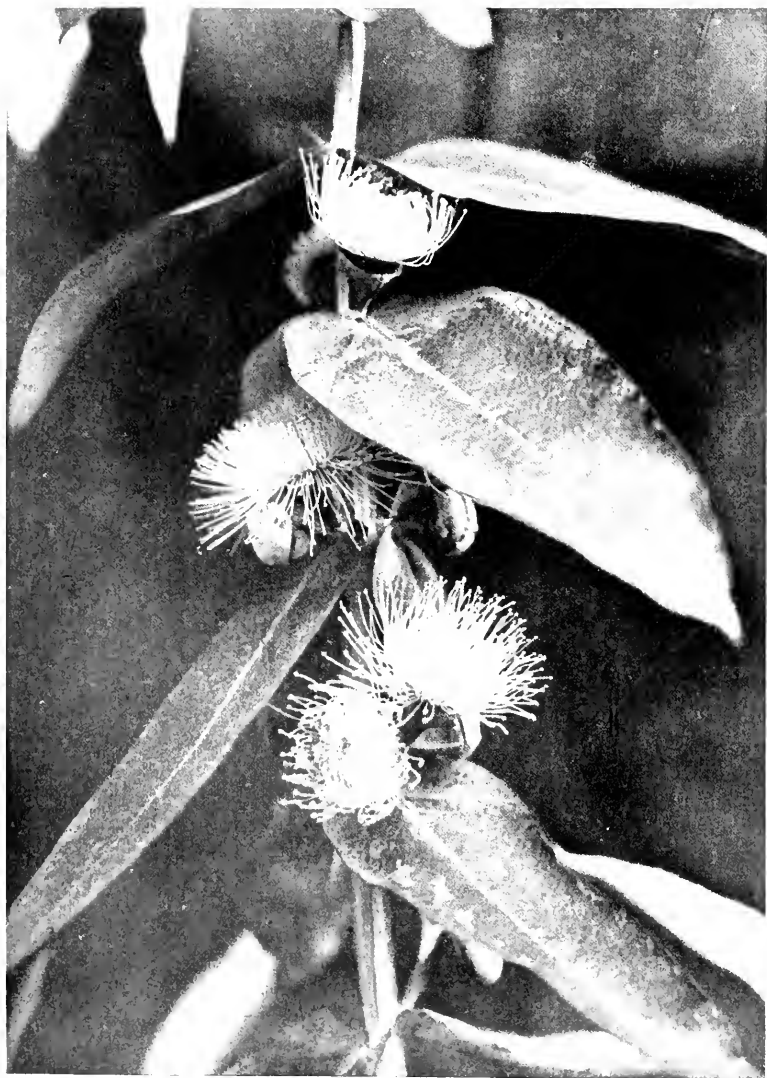





**XV. Quantitative Absorption Spectra, Part I. The chemical significance of absorption spectra and the methods of examining them.**

By FREDERICK RUSSELL LANKSHEAR,  
B.A. (N.Z.), M.Sc. (Vict.).

*Read May 12th, 1914. Received for publication September 19th, 1914.*

Of recent years much attention has been given to the study of the relation between the physical properties and the chemical constitution of organic compounds. As a result, knowledge of the internal structure of the molecule has been greatly advanced. Not only have the relative positions of the atoms in the molecule been more precisely determined, but deductions have begun to be drawn from experimental facts as to the nature of the forces which hold atoms together in a state of combination. No branch of this subject would seem bigger with possibilities than the study of colour. Colour, whether in the ultra-violet or visible regions, can easily be examined by means of a spectrograph, it is a very characteristic property, in many cases it is clearly allied to a definite structure, as in the case of the  $\alpha$ -diketones, and yet it must be confessed that the results of the past thirty years' work have been disappointing. It is true that the theory concerning visible colour put forward by Witt and elaborated by Hantzsch, Kauffmann and others is applicable to a wide range of substances including the dyestuffs, but it is rather a coordinated summary of observed facts than an explanation of the origin of colour. In the field of ultra-violet colour, the work of Hartley, Baly, Hantzsch and

*October 16th, 1914.*

others has led to some useful generalisations, yet here again no really satisfactory theory of cause has yet been put forward. One reason, and perhaps the chief one, for the present state of affairs, is that the method of examining colours has been largely qualitative.

In the following pages a brief description of the method at present in use for the study of ultraviolet absorption spectra is given, together with a short summary of the more important generalisations arrived at. A new instrument is then described which permits quantitative measurements of the amount of light absorbed by a given quantity of a substance.

The present, or Hartley method, was suggested by Hartley in 1879 (*Proc. Roy. Soc.*, 28, p. 233). It has been considerably developed by Dobbie, Baly, Purvis and others.

#### THE HARTLEY METHOD.

*Apparatus.* The apparatus used consists of a source of ultraviolet light, a quartz condenser, a suitable quartz-ended containing vessel for the substance under examination, and a quartz spectrograph in which the transmitted light is allowed to fall on a photographic plate after dispersion.

*Source of Light.* A spark from a six inch induction coil is passed between suitable electrodes with a condenser in parallel. An iron arc is also sometimes used. The choice of the electrodes is a matter of some difficulty, but the Jones' form is the most serviceable. This consists of carbon poles impregnated at a red heat with uranium acetate and ammonium molybdate. The tips are wedge-shaped, and the long edges are placed parallel to the optic axis. The spark gap is about 5 mm. The spectrum of this spark is very rich in ultraviolet light, and

consists of many strong lines on an almost continuous background.

*The Containing Vessel.* Hartley used small quartz-sided cells which held a definite thickness of solution. Baly has, however, effected a great improvement. The Baly tube consists of two concentric glass tubes, one end of each of which is closed with a quartz plate. A piece of rubber tubing serves to make a tight joint, and to allow the smaller tube to move freely inside the larger. The latter is provided with a bulb which acts both as an entrance and as a reservoir to the apparatus. The side of the larger tube has engraved on it either thicknesses in millimeters or the logarithms of corresponding thicknesses.

*The Spectrograph.* Any spectroscope will do if fitted with an optical train transparent to ultraviolet light and with a camera attachment, but it is desirable that the dispersion should give a spectrum about seven inches long from wave length  $\lambda = 8,000$  to  $2,000$ ,\* all of which should be in focus at the one time.

*Solvents.* The ideal solvents are those which are perfectly transparent between the above-mentioned limits. It is doubtful, however, if any do fulfil that condition, although some such as water, alcohol, and chloroform show, in the pure condition, very little absorption. Still, alcohol usually begins to show absorption at  $3,200$ , and bad specimens may transmit a weakened spectrum over the whole of the ultraviolet.

*Plates.* Most plates are sufficiently sensitive down to  $\lambda = 2,500$ , beyond which region the photographic image falls off in intensity, partly through the weakness of the rays but probably to a greater extent through absorption by the materials of the plate. In the examination of this

\* All wave lengths are given in Ångstrom units

region recourse must be had to relatively long exposures. Experiments are in progress for the making of a plate at once sensitive and fast in the region  $\lambda = 3,000$  to  $2,000$ .

The plates are treated by the ordinary photographic methods.

*Exposure.* Exposures of from 15 to 20 seconds usually give a readable plate, but, as is shown elsewhere, a readable plate does not necessarily mean a correct plate.

*Plotting Results.* In taking the photograph, a suitable concentration of the substance being studied is chosen, and exposures taken through thicknesses such as 50, 40, 35, 30, 25, 20, 17, 15, 12, 10, 8, 6, 5 mm. If necessary the solution is then diluted down to one-tenth the strength, and the process repeated. Between each exposure the plate is racked forward sufficiently to prevent the overlapping of the successive spectra.

After development the plate is read. This is done by placing on the plate a wave length scale and reading off the wave length of the last line visible in the given exposure. In many instruments there are arrangements for photographing a wave length scale directly on to the plate. The curve can then be plotted. It is usual to plot oscillation frequencies as abscissae and logarithms of relative thicknesses in millimeters of  $M/10,000$  solution as ordinates.

*Types of Curves* In general, it is found that two distinct types of absorption occur, (*a*) general, (*b*) selective.

The general absorption curve may be either straight or may have one or more bends in it, which in some instances take the form of steps. Up to the present time this form of curve has had only a restricted significance for chemists, and is associated with aliphatic compounds and completely saturated aromatic compounds like hexahydrobenzene.

The curve of selective absorption has one or more maxima and minima, and the portions of the curve about a minimum are said to form an absorption band and the minimum itself is called the head of the band. The vertical distance from a minimum to its adjacent maximum is termed the persistence of the band, and is the range of dilution over which the band occurs. It thus forms a rough measure of the strength of the absorption.

*Generalisations.* Certain conclusions have been arrived at which will probably continue to hold good for some time, although the use of more scientific methods may be expected to give them a somewhat different form.

The following summary, though not complete, will give some idea of their nature.

1. Aliphatic bodies give general, aromatic give selective absorption. Numerous exceptions exist on both sides. For instance, aliphatic compounds containing the group  $-\text{CO}\cdot\text{CH}_2-$ , in which keto-enol tautomerism to the form  $-\text{COH}=\text{CH}-$  is considered to occur, show selective absorption, especially in their metallic derivatives, such as  $-\text{CONa}=\text{CH}-$ . The same is true of aliphatic  $\alpha$ -diketones containing the group  $-\text{CO}\cdot\text{CO}-$ . In this case it is supposed that a reversible change to the form

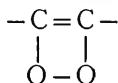

occurs. As regards aromatic compounds, the case of hexahydrobenzene has been already referred to. This may, however, be regarded almost as an aliphatic body, but the general absorption of aniline,  $\text{C}_6\text{H}_5\text{NH}_2$ , is not capable of the same explanation.

2. Substances having analogous constitutions give similar absorption spectra. This statement, first put forward by Hartley in connection with the alkaloids, needs

some qualification. In the first place it is true only of complicated bodies, and then only when the substituent is optically inert, *e.g.* when  $-\text{OH}$  becomes  $-\text{OMe}$ .

3. Persistence and reactivity are closely related. This is well brought out in the substituted benzoquinones, where decrease in persistence is accompanied by a corresponding decrease in the ease of oxime formation. In the tetra substituted quinones the quinone band disappears and no oximes can be formed.

4. Definite groups tend to give their band always at the same dilution and wave length. Thus the  $\alpha$ -diketone band is just at the edge of the visible spectrum and is given in N/10 solutions. These substances are thus characterised by their yellow colour. The difficulties surrounding the subject of colour will be appreciated when it is remembered that very many yellow bodies exist which cannot have an  $\alpha$ -diketonic structure.

5. Finally, both selective absorption in the ultra-violet and ordinary visible colour are connected with the existence in the molecule of one or more centres where the chemical potential, or reactivity, is high.

The above statements, although subject to many reservations, show the nature of the considerations which affect the study of absorption spectra.

Various theories have been put forward of the origin of selective absorption in organic compounds based on the qualitative curves which the Hartley method gives, but it is highly desirable that there should be accumulated a large body of data derived from a more scientific method. Certain criticisms to which the former method is open may be made under the following heads: (*a*) source of light, (*b*) exposure, (*c*) absorption of light by other than the substance being studied, (*d*) change in constitution on dilution, (*e*) difficulties in reading the plate.

*Source of Light.* The spectra of most, if not all, sources of light contain weak regions where both the maximum intensity of individual lines and the average intensity of the region are less than in the surrounding regions. There is thus a tendency to the formation of a spurious band at this point, and where a genuine band occurs at this wave length the effect will be liable to exaggeration.

*Exposure.* Under average conditions an exposure of 15 to 20 seconds is sufficient to produce a fairly dense and readable plate. Changes in the time of exposure do, however, greatly affect the position of the curve with reference to the concentration. Bands tend to become narrower with longer exposure.

Thus, since no convention exists as to a light source of standard intensity, it is only by chance that the curves for a given substance obtained by two independent workers will be perfectly superposable. As a rule, for the purposes for which the method has mostly been used, this is not serious, but it is a fatal objection to methods of analysis based on absorption spectrum measurements.

*Extra Absorption.* Three sources of error are summed up under this term, absorption by the solvent, scattering of ultraviolet light by fine suspended impurity, and absorption in the region  $\lambda = 3,000$ — $2,000$  by the materials of the plate itself. The second may easily be remedied by good filtration, but is often overlooked, the first and the third are serious. Hartley in his paper quoted above gives a list of solvents transparent to ultraviolet light down to  $\lambda = 2,000$ . This list appears to have been accepted without question by chemists. But it is easy to show in every case that weakening of the transmitted spectrum occurs as  $\lambda = 2,000$  is approached. To take the case of alcohol; an ordinary specimen of Kahlbaum's

pure absolute alcohol will be found to show signs of absorption at  $\lambda = 3,000$  through a length of 100 mm., and even after careful fractionation over a few drops of sulphuric acid, followed by similar treatment with lime, absorption will show up between  $\lambda = 2,800$  and  $\lambda = 2,000$ . Gelatine absorbs ultraviolet light of short wave length, and, since in the ordinary plate the silver bromide grains are embedded in gelatine, they do not receive all the light of short wave length which falls on the plate. The sensitiveness to waves from  $\lambda = 2,500 - 2,000$  varies very much, but in all ordinary plates the effect becomes strong as the wave length  $\lambda = 2,000$  is approached. Hence, for measurements in this region, Schumann plates should be used, in which variety a minimum of gelatine is used. Unfortunately, these are not on the market and must be prepared when required.

*Changes in constitution on dilution.* This difficulty is not very common, but it manifests itself occasionally in a sudden break in the curve at the point where the solution has been diluted. For an example, see the camphor quinone  $\alpha$ -hydrazone and  $\alpha$ -semicarbazone. (*J. C. S.*, 99, p. 1786.)

*Reading the Plate.* It is usual in reading off the point where a band begins to regard the last line visible as the edge of the band. This works well enough with portions of curves near the visible, but the greater part of the ultraviolet spectrum is diffuse and certain strong lines persist long after weaker ones have disappeared. This trouble can be got over to a certain extent by using another source of light, but it will always remain a cause of uncertainty and additional labour.

*Quantitative methods.* An interesting quantitative method has recently been developed by M. Henri (*Phys. Zeit.*, 1913, pp. 513-516), which will be briefly described



Twenty-three spectra of exactly five seconds exposure are spaced across a plate, leaving room for another exposure between each. The gaps are then filled with spectra transmitted through varying lengths of the solution for various exposures. Thus :

| Standard Spectrum. | Transmitted Spectrum<br>(Through 2 mm. of Solution). |
|--------------------|--|
| Secs.              | Secs.  |
| 5                  | 90   |
| 5                  | 60   |
| 5                  | 40   |
| 5                  | 30, etc.   |

After development, those points are noted at which the transmitted and standard spectrum have the same intensity. By applying the Schwartzschild formula for the intensity of the photographic image, and Beer's law, the extinction coefficient for various wave lengths can be arrived at. For instance, in the above example, the transmitted and standard beam will be of equal intensity at a certain point,  $\lambda$ , for the exposure 90 secs. and the length 2 mm. The two laws can now be applied, in the forms—

$$\frac{I}{I_1} = \left(\frac{t}{t_1}\right)^n$$

(Schwartzschild's formula for the density of the photographic image where  $I$  and  $I_1$  are intensities  $t$  and  $t_1$  times of exposure, and  $n$  a number depending on the make of plate, '9 in the Wratten panchromatic plate), and

$$I_1 = I \cdot 10^{-kd}$$

(Beer's law where  $I_1$  is the intensity of the transmitted beam,  $I$  that of the original beam,  $k$  a constant, and  $d$  the thickness of layer traversed).

Combining the two formulæ and substituting the numerical values, we have

$$K = \frac{9}{.2} \log \frac{90}{5} = 5.65.$$

$K = \epsilon c$  in the expression of Beer's  $I_1 = I_0 \cdot 10^{-\epsilon c d}$ , where  $\epsilon$  is the extinction coefficient and  $c$  the concentration in gram molecules per litre. It is thus possible by a choice of suitable thicknesses and exposures to evaluate  $\epsilon$  over the whole range of the absorption band.

M. Henri and his co-workers have examined a number of substances and have drawn several generalisations of interest which will be considered in a later communication. Their method is open to criticism, and it is computed that errors of the order of 30 per cent. may affect their figures.

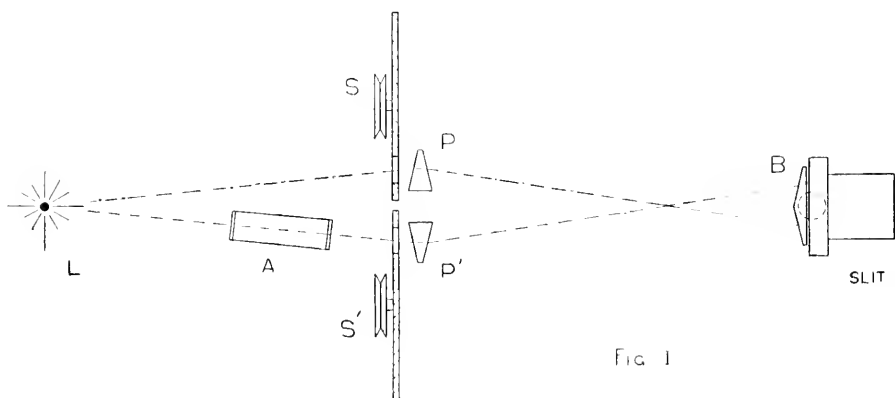
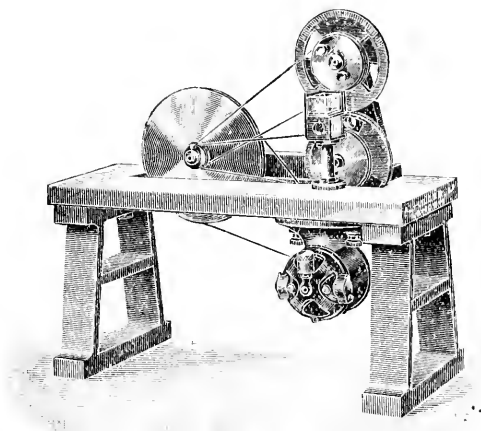

Fig. 1.

The first and most serious of these errors relates to the standard spectrum. They made the exposure as exact as possible by means of the rotating sector commonly used in photographic measurements, but there is always the possibility of variation in the light source, which is the condensed cadmium and iron spark. Further, the accuracy of Schwartzschild's formula is assumed over the whole range of the spectrum, for any plate, and for any value of  $t$ . These defects are overcome in the method about to be described. In this latter, due to

Messrs. Hilgers, a beam of light is divided into two equal portions by a pair of deflecting windows of quartz. The lower beam then passes through a rotating sector of fixed aperture, and through a cell of definite length, containing the solution under examination. It then falls on a biprism fixed to the slit of the spectrograph. The upper beam after deflection passes through a rotating sector, the aperture of which is adjustable. It then traverses a cell identical with the lower one containing the solvent and falls on the biprism. The two images come to a



*Fig. 2.*—General appearance of apparatus.

focus on the object glass of the spectrograph, and form on the plate two spectra side by side and just touching. A blank photograph gives two spectra of equal intensity over their whole range. By means of the adjustable sector the strength of the standard beam can be cut down by any known amount, the logarithm of the ratio of the two apertures giving  $\log. I/I_1$ . As in the Henri method, those points are read off at which the standard beam and the transmitted beam are of equal intensity,

*i.e.*, points where  $\log. I/I_1$  = the log. of the aperture ratio. For simplicity, the adjustable sector is graduated logarithmically. From a knowledge of  $d$ , the length of solution, and  $c$ , the concentration, and  $\log. I/I_1$ ,  $\epsilon$ , the extinction coefficient, is readily calculated from the formulas  $I_1 = I \cdot 10^{-\epsilon c d}$ , where  $\epsilon$  is the extinction coefficient,  $c$  the concentration, and  $d$  the thickness.

The chief assumption in this method is the truth of Schwartzschild's formula. This has been obviated by calibrating each batch of plates used, and often various plates of the same batch, with a piece of glass of known extinction coefficient in the ultraviolet. Usually a small correction has to be applied to the value of  $\log. I/I_1$  = log. of aperture ratio. Variations in the intensity of the light source have no effect since the standard and transmitted beam are used simultaneously. Some disadvantages of the method are the necessity of frequently calibrating the plates, the long exposures required for the extreme ultraviolet (of the order of 500 secs.) and the short length of solution which can be used, 5 cms. as a maximum. The advantages are: independence of variation of the light source, ease of reading, for the plates give the wave length and  $\log. I/I_1$  directly, and the automatic allowance for the effect of the solvent.

It is hoped shortly to describe an instrument in which the Baly tube can be used, which gives a steady instead of an intermittent beam on the slit, thus obviating the Schwartzschild correction, and, finally, focussing the image of the light source on the slit instead of the object glass.

PROCEEDINGS  
OF  
THE MANCHESTER LITERARY AND  
PHILOSOPHICAL SOCIETY.

---

Ordinary Meeting, October 7th, 1913.

The President, Mr. FRANCIS NICHOLSON, F.Z.S.,  
in the Chair.

Mr. C. L. BARNES, M.A., called attention to the recent accessions to the Society's Library, and a vote of thanks was passed to the donors of the books upon the table. The following works were included in the recent accessions to the Society's Library: "*A Bibliography of the Tunicata*," 1469-1910, by John Hopkinson (8vo., London, 1913), and "*The British Parasitic Copepoda*," Vols. 1 and 2, by T. and A. Scott (8vo., London, 1913), published by the Ray Society, purchased; "*The Leeches of Minnesota*" (Zoological Series, No. V.), by H. F. Nachtrieb and others (8vo., Minneapolis, 1912), presented by the Geological and Natural History Survey, Minnesota; "*Geologic Atlas of the United States*," Folios Nos. 183, 184 and 186 (fol. Washington, D.C., 1912), presented by the United States Geological Survey; "*Descriptive account of the Chinese, Tibetan, Mongol and Japanese Books in the Newberry Library*," by B. Laufer (8vo., Chicago, Ill., 1913), presented by the Newberry Library, Chicago; "*Observaciones en la Mina Águila, 5,200 m...*" por Walter Knoche, and "*Anuario Meteorológico de Chile*," 1911 [2 parts]. (Publicaciones Nos. 1 and 3) (fol., Santiago de Chile, 1911 and 12), presented by the Instituto Central Meteorológico y Geofísico de Chile, Santiago; "*Hoekijzerverbindingen*

*in het bijzonder die der Langs aan Dwarsdragers in Bruggen,*" door J. H. A. Haarman (8vo., Delft, 1913), "*Tektonische und Stratigraphische Beobachtungen am südwestrande des Limburgischen Kohlenreviers,*" W. C. Klein, (fol., Amsterdam, n.d.), "*Snelheidsmetingen bij de Reactie van Friedel en Crafts...*," door S. C. J. Olivier (8vo., Delft, 1913), "*Overheidsbemoeiingen met Stedebouw tot aan den Vrede van Munster ...*" door W. B. Peteri (8vo., Alkmaar, 1913), "*Bijdrage tot de Kennis der Katalyse...*" door H. J. Prins (8vo., Amsterdam, n.d.), "*Het Sociale Arbeidscontract...*," door J. van Hettinga Tromp (8vo., Amsterdam, 1913), and "*Over eenige factoren, die de ontwikkeling van Penicillium glaucum beïnvloeden . . .*," door H. I. Waterman (8vo., n.p., n.d.), presented by the Technische Hoogeschool, Delft; "*Official Year-Book of the Commonwealth of Australia,*" 1901-1911, No. 5, by G. H. Knibbs (8vo., Melbourne [1912]), presented by the Commonwealth of Australia; "*Reprints of Papers from the Science Laboratories of the University of Sydney, 1908-9 to 1911-12, A. From the Departments of Mathematics, Physics, Chemistry and Engineering*" (8vo., Sydney, 1912), presented by the University of Sydney, N.S.W.; "*The History of the Collections contained in the Natural History Departments of the British Museum. Vol. II.-Appendix,*" by Albert Günther (8vo., London, 1912); "*A Revision of the Ichneumonidae based on the Collection in the British Museum (Natural History),*" Part II., by Claude Morley (8vo., London, 1913); "*Catalogue of the Heads and Horns of Indian Big Game bequeathed by A. O. Hume, C.B., to the British Museum (Natural History),*" by R. Lydekker (8vo., London, 1913), and "*The House-Fly as a Danger to Health. Its life-history and how to deal with it,*" by E. E. Austen (8vo., London, 1913), presented by the British Museum (Natural History); "*The Physiography of the Rio Grande Valley, New Mexico,*" by E. L. Hewett and others (Bulletin No. 54), (8vo., Washington, 1913), presented by the Bureau of American Ethnology, Washington, D.C.; "*The California-Washington Arc of Primary Triangulation,*" by A. L. Baldwin (Special Publication, No. 13), (4to., Washington,

1913), and "*Determination of Time, Longitude, Latitude, and Azimuth*," by W. Bowie (Special Publication, No. 14), (4to., Washington, 1913), presented by the United States Coast and Geodetic Survey, Washington, D.C.; "*A History of the First Half-Century of the National Academy of Sciences, 1863-1913*" (4to., Washington, D.C., 1913), presented by the National Academy of Sciences, Washington; "*Rapporten van de Commissie in Nederlandsch-Indië voor Oudheidkundig Onderzoek op Java, en Madoera*" (8vo., Batavia, etc., 1913), presented by the Bataviaasch Genootschap van Kunsten en Wetenschappen, Batavia.

Mr. NICHOLSON thanked the Members of the Society for the honour they had done him in electing him to the Presidency.

Mr. WILLIAM CRAMP, M.Sc.Tech., M.I.E.E., exhibited and made some remarks upon a Brabbée tube, used for measuring air quantities, velocities and pressures.

The PRESIDENT reported that on September 26th last a Wheat-Ear had been observed by Mr. Idle, of the Manchester Reference Library, on the old Infirmary site, where it remained for two or three days, feeding on insects and appearing as much at home as if it were in its natural surroundings on the hilly districts of the north of England. Mr. Nicholson commented also on the presence of Starlings in the same locality during the past summer, and further visits by Wheat-Ears on two dates at the end of August.

The PRESIDENT read an inaugural address on "**The Old Manchester Natural History Society and Its Museum.**"

This Address is printed in full in the *Memoirs*.

Professor F. E. WEISS read a paper, entitled "**Juvenile Flowering in *Eucalyptus globulus*.**"

This paper will be printed in full in the *Memoirs*.

General Meeting, October 21st, 1913.

The President, Mr. FRANCIS NICHOLSON, F.Z.S.,  
in the Chair.

Mr. A. D. IMMS, M.A., D.Sc., Reader in Agricultural Entomology in the Victoria University of Manchester, was elected an ordinary member of the Society.

---

Ordinary Meeting, October 21st, 1913.

The President, Mr. FRANCIS NICHOLSON, F.Z.S.,  
in the Chair.

A vote of thanks was accorded the donors of the books upon the table.

A paper, entitled "**Changes in the branchial lamellae of *Ligia oceanica* after prolonged immersion in fresh and salt water,**" by Miss DOROTHY A. STEWART, B.Sc., was read by Professor Hickson, F.R.S.

This paper is printed in full in the *Memoirs*.

Dr. H. G. A. HICKLING exhibited a series of **Old Red Sandstone Fish**, from the Manchester Museum, presented by Mr. D. M. S. Watson, M.Sc., and he alluded to the completeness and to the valuable nature of the collection of fishes from these rocks now contained in the Museum. A brief account was given of the chief features of interest of the specimens exhibited and of the bearing of these fish remains on the early history of the vertebrates.

---



Ordinary Meeting, November 4th, 1913.

The President, Mr. FRANCIS NICHOLSON, F.Z.S.,  
in the Chair.

A vote of thanks was accorded the donors of the books upon the table. The accessions included: "*Biography and Unparalleled Discoveries of T. J. J. See*," by W. L. Webb (8vo., Lynn, Mass., 1913), presented by the Author; "*The Mental and Physical Life of School Children*," by Peter Sandiford (8vo., London, 1913), presented by the Author; "*Index to the Proceedings of the Royal Society, Vols. 1-75, 1800-1905*" (8vo., London, 1913), purchased; "*Acrididen Japans*," by T. Shikari (8vo., Tokyo, 1910) and "*Monographie der Grylliden*" von Formosa," by T. Shikari (8vo, Taihoku, 1911), presented by the Bureau of Productive Industries, Government of Formosa.

The PRESIDENT referred to the death of Mr. W. H. SUTCLIFFE, F.G.S., a member of the Society, and the reader of an important paper on "Some Modern Tendencies in Pre-historic Anthropology" before the Society last March.

Mr. G. P. VARLEY, M.Sc., exhibited a fused mass of common salt which had remained in a saturated solution of the same substance for four years. The mass had lost its rounded surface, and was covered with portions of large crystals.

A small roll, examined at the British Museum and stated to be a prayer or charm in Sanskrit, written in Tibetan script, was shown by Mr. C. L. BARNES, M.A.

The PRESIDENT read an extract relating to certain plants, i.e., *Rhus toxicodendron* (the 'poison ivy'), and a species of *Primula*, which are supposed to have been, on more than one occasion, the cause of eczema and similar skin eruptions in persons cultivating them or living in close proximity.

A paper entitled "**Note on some products isolated from Soot,**" by Professor EDMUND KNECHT, Ph.D., and Miss EVA HIBBERT, was read by the former.

This paper is printed in full in the *Memoirs*.

Professor H. C. H. CARPENTER, M.A., Ph.D., read a paper, entitled "**The crystallising properties of electro-deposited Iron.**" Specimens of electro-deposited iron sheet of a high degree of purity have been found to exhibit remarkable re-crystallisation effects when heated above the  $Ac_3$  change and then cooled below the  $Ar_3$  change. In this way relatively enormous crystals are formed in three seconds after cooling below  $Ar_3$ . The coarse crystals are sometimes "equi-axed" and sometimes "radial." Frequently both types occur on the same specimen. There is no reason for thinking that they are constitutionally different, and they are most probably  $\alpha$  iron. These crystallisation effects are only obtained when the thickness of the iron sheet or strip does not exceed a certain critical figure, which is between 0.011 and 0.012 of an inch. Once the coarse crystals are formed they cannot be destroyed, except either by mechanical work, or by heating above  $Ac_3$  followed by quenching, or by very prolonged heating above  $Ac_3$  followed by ordinary cooling rates.

The very heat treatment which produces coarse crystals in the electro-deposited iron refines wrought iron and very mild steel that have been rendered coarsely crystalline by "close-annealing" between  $700^\circ$  and  $800^\circ$  C. On the other hand, annealing at  $700^\circ$  to  $800^\circ$  C. has no effect in coarsening the structure of the electro-deposited iron which has been refined by cold mechanical work. In these respects, therefore, the behaviour of electro-deposited iron is precisely the opposite of that of wrought iron and mild steel.

---

Ordinary Meeting, November 18th, 1913.

The President, Mr. FRANCIS NICHOLSON, F.Z.S.,  
in the Chair.

A vote of thanks was accorded the donors of the books upon the table. The recent accessions included: "*The Celebration of the 250th Anniversary of the Royal Society of London, July 15—19, 1912*" (4to., London, 1913), presented by the Royal Society of London; Thirty Theses, presented by the Kaiserliche Universitäts- und Landes-Bibliothek, Strassburg; and "*An Index to the Journal and Proceedings of the Academy of Natural Sciences, Philadelphia, 1812—1912*" (8vo., Philadelphia, 1913), purchased.

A paper, entitled "**The Controversies concerning the Interpretation and Meaning of the Remains of the Dawn-Man found near Piltdown,**" was read by Professor G. ELLIOT SMITH, M.A., M.D., F.R.S.

The author referred to the fact that on February 18th, last, he was able to exhibit to the Society plaster casts of the fragments found last year near Piltdown, Sussex, which Dr. Smith Woodward kindly sent him for the purpose of that meeting. On that occasion he gave an account of our knowledge of ancient man, and explained the new light which these interesting Sussex remains shed upon the general problem of the Antiquity of Man.

Since then memoirs by Mr. Charles Dawson and Dr. Smith Woodward have appeared (*Quart. Journ. Geol. Soc.*, March, 1913), relating to the circumstances under which the fragments were found, the nature of the material itself, and the objects found with them. Mr. W. H. Sutcliffe also gave us a discourse (*Manchester Memoirs*, Vol. 57, No. 7), in which he most admirably summed up the evidence as to the nature of the remains of ancient man in England, and incidentally discussed the evidence bearing upon the date of the Piltdown remains.

While agreeing with practically all that Mr. Sutcliffe wrote in his memoir, Professor Elliot Smith criticized his phylogenetic scheme published as *Plate I*.

Professor Elliot Smith then proceeded to explain the nature of the controversies concerning other bearings of the Piltdown discovery on the history of ancient man:—(1) 'The age of the remains; (2), the question of the association of the jaw and the skull; (3), the significance of the jaw and teeth and the reconstruction of the missing parts; (4), the reconstruction of the brain-cast and the nature of the brain; and (5), the place which *Eoanthropus* should occupy in the phylogeny of the Hominidae.

(1) As regards the age—whether the fragments are Pleistocene or Pliocene—he said it was practically certain that they are of the Pleistocene date.

(2) That the jaw and cranial fragments found in the neighbourhood belonged to the same creature there had never been any doubt on the part of those who have seriously studied the matter. There is definite internal evidence that the jaw is not really an ape's; the teeth it bears are human, and the skull, although human, is much more primitive than any skull assigned to the genus *Homo*. This association of skull and jaw is precisely of the kind which on *a priori* grounds we should expect in an ancestral type of man.

(3) The reconstruction of the jaw and teeth has now been practically settled once for all by the subsequent discovery of the canine tooth.

(4) With regard to the reconstruction of the skull, Professor Elliot Smith thought there was no longer any room for doubt as to the position the fragments originally occupied in the skull, and he considered it highly improbable that the complete brain-cast could be more than 1100 cc. in capacity. He thought he was justified in saying that this was a maximum estimate.

(5) Referring to the position of *Eoanthropus* in relation to the ancestral tree of man, he was of opinion that there could be no question of the ample justification for putting the Piltdown remains into a genus separate from all the other Hominidae, for

while in certain respects they resemble modern man much more closely than the Neanderthal group does, yet they are so definitely much more primitive and so unmistakably Simian in the character of the jaw and canine teeth that the distinction is amply justified. Having said this, the position of *Eoanthropus* in regard to the ancestry of the genus *Homo* is patent, for it must represent a persistent and very slightly modified descendant of the common ancestor of *Homo sapiens* and *Homo primigenius*.

The author argued that there is no positive evidence to show that the genus *Homo*, or even *Eoanthropus*, had come into existence in Pliocene times.

The fact of *Eoanthropus Dawsoni* being found in a deposit that may perhaps be as late as the Mid-Pleistocene does not invalidate the conclusion that the genus to which it belonged was ancestral to the Heidelberg man. It was shown by analogy with the histories of other phyla (such as the Titanotheres, studied by Osborn) that the occurrence of large eyebrow-ridges in *Homo primigenius* is no valid objection to the acceptance of this view.

When man was first evolved the pace of evolution must have been phenomenally rapid, by reason of the rapid weeding-out of those who were not fleet of foot and nimble-witted to meet the dangerous new conditions. Thus in view of the fact that no human remains or undoubted evidence of human workmanship are known earlier than the Pleistocene, it is quite possible that amidst the turmoil incidental to the inauguration of the Pleistocene Period a group of anthropoids rose superior to the difficulties of new circumstances and became "Dawn-men."

It is impossible to give a definite opinion as to whether the Piltdown individual possessed the power of articulate speech, but it is almost certain that man began to speak when his jaw was in the stage represented in that of *Eoanthropus*. The brain of the creature can be called human, and already shows considerable development of the parts which in modern man we associate with the power of speech.

---

Ordinary Meeting, December 2nd, 1913.

Professor F. E. WEISS, D.Sc., F.L.S., Vice-President,  
in the Chair.

A vote of thanks was accorded the donors of the books upon the table. Amongst these was "*Results of Observations made at the United States Coast and Geodetic Survey Magnetic Observatory, near Honolulu, 1911 and 1912*," by D. L. Hazard (4to, Washington, 1913), presented by the United States Coast and Geodetic Survey.

Professor WEISS, in referring to the loss sustained by the death of Sir William H. Bailey, spoke of the deep regret felt by the members of the Society at his loss. Sir William Bailey had been a Member of the Society for twenty-five years, and had held the office of President for the years 1905-6 and 1906-7. He was also a Vice-President for five years. Mr. R. L. Taylor represented the Society at the funeral.

A resolution, expressing the sympathy of the members of the Society with the members of the family of the deceased in the great loss they had sustained, was passed, and the Secretaries were requested to convey this expression of sympathy to the members of the family.

Professor ERNEST RUTHERFORD, D.Sc., F.R.S., read a paper on "**The Structure of the Atom.**"

In a paper given to this Society two years ago he described a new type of model atom which has since been called the "Nucleus Atom." It was supposed that the atom consisted of a central nucleus, probably charged positively, of exceedingly small dimensions, in which practically all the mass of the atom was concentrated. This was surrounded by a distribution of negative electrons, sufficient to make the atom electrically neutral. This type of atom was specially devised in order to explain the fact that the swift  $\alpha$  particles in traversing matter are occasionally deflected through more than a right angle as

the result of a single encounter with another atom. It was deduced that the number of electrons and consequently the charge on the nucleus was numerically equal to about half the atomic weight. A brief account was given of later experiments in support of this view of the structure of the atom. In an important series of experiments Geiger and Marsden have shown that the large angle scattering of  $\alpha$  particles is in very close agreement with this assumption of the constitution of the atom. In particular, they showed that the variation of the number of  $\alpha$  particles scattered through different angles by different elements agreed closely with the theory over a range in number of nearly one million times. The deflection of the  $\alpha$  particle is due to its passage close to the intense field of the nucleus. As a result of such a close encounter, the atom with which the  $\alpha$  particles collides is set in motion, the velocity depending upon its mass. Special interest attaches to the scattering of  $\alpha$  particles by the passage through a light gas like hydrogen, since it is to be expected theoretically that a small fraction of the hydrogen atoms should acquire a velocity even greater than the  $\alpha$  particle itself. This question is now under experimental examination by Mr. Marsden, and he has found definite evidence that some of the hydrogen atoms actually acquire such a great velocity by their encounters with  $\alpha$  particles that they are able to travel through hydrogen at least three times the distance of the  $\alpha$  particle itself through the same gas. These swift hydrogen atoms are detected by their property of producing scintillations in a zinc sulphide screen.

On the nucleus theory it is supposed that the hydrogen atom contains one positive charge and the helium two. The number of hydrogen atoms which are set in rapid motion is of about the order to be anticipated from this point of view. There is one very interesting deduction that can be made from such experiments. It was pointed out two years ago that the diameter of the nucleus even of a heavy atom like gold was exceedingly small, viz., about  $10^{-12}$  cms., compared with the ordinary accepted diameter of the atom, viz.,  $10^{-8}$  cms. In order to

account for the production of such swift hydrogen atoms as are observed, the centres of the two nuclei must approach within a distance of each other of  $2 \times 10^{-13}$  cms. This distance is about the same magnitude as the diameter of the electron. Remembering that this gives a maximum estimate of the diameter of the nucleus of the hydrogen or helium atom, it is obvious that the nucleus must have exceedingly small dimensions. If the mass of the hydrogen atom is electromagnetic in origin, according to present theories, it should have a diameter about  $1/1800$  of the diameter of the electron. While at present there is no experimental evidence to give a minimum estimate of the diameter of the hydrogen nucleus, it does not seem improbable that it may have the minute dimensions necessary for its mass to be entirely electromagnetic in origin. On such a view the charged hydrogen atom is to be regarded as the positive electron. Such a view has been proposed at various times, and the proof of the minute dimensions of the hydrogen nucleus certainly adds weight to this suggestion.

It has recently been suggested by A. van der Broek and Bohr that the charge on the nucleus is not given by a number equal to half the atomic weight but is equal to the number of the element when arranged in a series of increasing atomic weights. On this view, for example, the charges on the nuclei are for hydrogen, helium, lithium, carbon and oxygen 1, 2, 3, 6, and 8, respectively. The experimental evidence is distinctly in favour of this view, and it has been supported by the recent experiments of Moseley in *The Philosophical Magazine*. A brief account was given of the attempts made by Bohr and others to explain in detail the constitution of the simple atoms and the spectra to which they give rise. It was pointed out that the chemical and physical properties of the atom are ultimately determined by the charge on the nucleus, which should consequently be a more fundamental constant than the atomic weight. The latter will depend on the inner structure of the nucleus, and may not be proportional to the charge on the nucleus

---



General Meeting, December 16th, 1913.

The President, Mr. FRANCIS NICHOLSON, F.Z.S.,  
in the Chair.

Miss MARION HANDLEY, M.A., Lecturer in the Municipal Day Training College, Manchester, of "*Himmel*," *Burnage Garden Village, Manchester*, was elected an Ordinary Member of the Society.

---

Ordinary Meeting, December 16th, 1913.

The President, Mr. FRANCIS NICHOLSON, F.Z.S.,  
in the Chair.

Dr. KURT LOEWENFELD exhibited a piece of Saphiringlass, as produced by Merck, of Darmstadt, possessing a dichroic property — reflecting brown rays and transmitting green.

Professor W. W. HALDANE GEE exhibited samples of Bakelite, an invention of Dr. Baekeland, obtained by the action of formaldehyde on phenols in the presence of small amounts of bases or alkalies. There are three types of the material, A, B and C. Of these, type C is harder than hard rubber or celluloid, and withstands solvents and most chemicals. It resists boiling water and steam; heat neither melts it nor softens it. It can be drilled and turned. It is tasteless and has no odour, and is a good insulator of heat and electricity. These properties make it very valuable for the manufacture of many articles of commerce and for experimental work.

Mr. R. L. TAYLOR, F.C.S., F.I.C., read a paper entitled "**The Action of Bleaching Agents on various Natural Colouring Matters.**" He pointed out that in estimating the

bleaching power of the ordinary bleaching agents the kind of colouring matter has to be taken into account. Colouring matters such as indigo and turkey-red are rapidly and completely bleached by either chlorine or hypochlorous acid, the former being on the whole the more active of the two. A solution of bleaching-powder, which is naturally strongly alkaline, acts very slowly indeed upon the above colouring matters. In ordinary unbleached linen, cotton, and jute, there appear to be two quite different kinds of colouring matter, one resembling those mentioned above, and rapidly bleached by chlorine and hypochlorous acid, while the other is quite unaffected by these bleaching agents, but is bleached by a solution of a hypochlorite containing little, if any, free alkali. The proportion of these two kinds of colouring matter varies. In linen and jute a considerable amount of the colouring matter is not affected by chlorine or hypochlorous acid, while in cotton the proportion unbleached by these agents is very small indeed. Still, cotton is not *completely* bleached by either chlorine or hypochlorous acid, even after prolonged exposure to those agents.

---

General Meeting, January 13th, 1914.

The President, Mr. FRANCIS NICHOLSON, F.Z.S.,  
in the Chair.

Mr. WILLIAM CHARLES JENKINS, Curator of the Godlee Observatory, the Municipal School of Technology, Manchester, was elected an Ordinary Member of the Society.

---

Ordinary Meeting, January 13th, 1914.

The President, Mr. FRANCIS NICHOLSON, F.Z.S.,  
in the Chair.

A vote of thanks was accorded the donors of the books upon the table. These included: "*Beschreibung der Griechischen Autonomen Münzen im besitze der Kön. Akademie der Wissenschaften zu Amsterdam*" (4to., Amsterdam, 1913), and "*Amaryllis*" (8vo., Amsterdam, 1913), presented by the K. Akademie der Wissenschaften zu Amsterdam; "*Divine Love Vindicated*," by H. W. Southworth (8vo., London [1911]), presented by the author; "*Chippewa Music—II.*," by F. Densmore (8vo., Washington, 1913), presented by the Bureau of American Ethnology; "*Catalogue of Loan Exhibition of Paintings... February and March, 1913*" (4to., Cardiff, 1913), and "*Handbook to the Exhibition of Welsh Antiquities, June-October, 1913*" (4to., Cardiff, 1913), presented by the National Museum of Wales; "*Katalog und Ephemeriden veränderlicher Sterne für 1914*," by Ernest Hartwig (8vo., Leipzig, 1913), presented by the Remeis-Sternwarte, Bamberg; and "*Les Prix Nobel en 1912*" (8vo., Stockholm, 1913), presented by the K. Vetenskap-Akademie, Stockholm.

Professor G. ELLIOT SMITH, M.D., F.R.S., showed a series of photographs of the Piltdown skull, taken by his assistant, Mr. Henry Gooding, which revealed a number of features putting beyond all doubt the accuracy of the reconstruction of the skull which he demonstrated to the Society two months ago.

A paper, entitled "**Some Notes on the Measurement of Air Velocities, Pressures and Volumes**," was read by Mr. WILLIAM CRAMP, M.I.E.E., M.Sc.Tech.

This paper will be printed in full in the *Memoirs*.

Ordinary Meeting, January 27th, 1914.

The President, Mr. FRANCIS NICHOLSON, F.Z.S.,  
in the Chair.

A vote of thanks was accorded the donors of the books upon the table. These included: "*Catalogue of current Mathematical Journals, etc.*," compiled by W. J. Greenstreet (8vo., London, 1913), presented by the Mathematical Association.

Mr. T. A. COWARD exhibited a headless peacock butterfly, *Vanessa io*, found amongst the contents of a cask received from Cambridgeshire. The insect, after a minimum of seven days in a headless state, was still alive.

A paper on "**The Willow Titmouse in Lancashire and Cheshire,**" was read by Mr. T. A. COWARD, F.Z.S., F.E.S.

This paper is printed in full in the *Memoirs*.

Dr. A. D. IMMS read a paper entitled, "**Observations on *Phromnia marginella* in India.**"

This paper will be printed in full in the *Memoirs*.

---

General Meeting, February 10th, 1914.

The President, Mr. FRANCIS NICHOLSON, F.Z.S.,  
in the Chair.

Mr. A. W. BOYD, M.A., *The Aiton, Altrincham, Cheshire* was elected an ordinary member of the Society.

---

Ordinary Meeting, February 10th, 1914.

Mr. R. L. TAYLOR, F.C.S., F.I.C.,  
in the Chair.

A vote of thanks was accorded the donors of the books upon the table.

Mr. ARTHUR ADAMSON, M.Sc.Tech., A.R.C.S., and Mr. D. THODAY, M.A., were nominated Auditors of the Society's accounts for the session 1913-14.

Mr. T. THORP, F.R.A.S., described an experiment he had been making to ascertain the pressure required to force a film of mercury between two plane surfaces varying from  $\frac{1}{4000}$  of an inch to  $\frac{1}{1500}$  apart. The apparatus used consisted of two planes of thick glass touching at their upper ends but having outlets and separated at their lower by means of a film of celloidin  $\frac{1}{1500}$  of an inch in thickness, the sides being sealed. The lower end communicated, by means of a **U** tube, with a manometer. The results obtained appear to show that  $p t = 7$  where  $p$  is lbs. per sq. inch and  $t$  the thickness in thousandths of an inch, within the above limits, e.g. where  $p$  is 21 lbs. per sq. inch then  $t = \frac{1}{3000}$  of an inch. The thickness of the film was checked by taking the number of interference bands given by sodium light from zero thickness to the point to which the mercury had reached at various pressures.

Mr. R. F. GWYTHER, M.A., read a paper entitled "**The Specification of the elements of Stress. Part III. The definition of the dynamical specification and a test of the elastic specification. A Chapter on Elasticity.**"

This paper will be printed in full in the *Memoirs*.

A paper by Mr. M. COPISAROW, B.Sc., on "**Carbon, its molecular structure and mode of oxidation,**" was postponed until the next meeting of the Society.

---

General Meeting, February 24th, 1914.

The President, Mr. FRANCIS NICHOLSON, F.Z.S.,  
in the Chair.

Mr. WILLIAM D EVANS, M.A., Richardson Lecturer in Mathematics in The Victoria University of Manchester, of 17, Harley Avenue, Victoria Park, Manchester, was elected an ordinary member of the Society.

---

Ordinary Meeting, February 24th, 1914.

The President, Mr. FRANCIS NICHOLSON, F.Z.S.,  
in the Chair.

A vote of thanks was accorded the donors of the books upon the table. These included: "*Catalogue of the Lending Library*" (8vo., London, 1914), presented by the Institution of Electrical Engineers, London; and "*A Binary Canon showing residues of Powers of 2 for Divisors under 1000, and Indices to Residues,*" by Lt. Col. Allan Cunningham (4to., London, 1910), presented by the Committee of the British Association.

The PRESIDENT referred to the death of Mr. William H. Johnson, B.Sc., on February 19th. Mr. Johnson had been a member of the Society since 1870, and had served both as a Vice-President (1897-1899) and as a member of the Council.

Mr. M. COPISAROW, B.Sc., read a paper entitled "**Carbon: its molecular structure and mode of oxidation.**"

In discussing the problem of the mode of oxidation of carbon from a logical standpoint, the author arrives at conclusions which were fully corroborated by the most recent experimental evidence. But admitting the formation of complexes, he attempted the elucidation of the structure of a carbon molecule as such. Here, after numerous attempts, he found that there were three distinct possibilities, varying as regards

connecting-bonds, for the representation of a carbon molecule. This is rather significant, as it suggests the constitutional formulæ for the three modifications of carbon. Correlating this with the calorimetric measurements and relative proportions of oxygen, used up in the formation of the complexes, the formula for each form of carbon can be deduced. This gives also the possibility of deducing the general formula for the complexes  $C_xO_y$ .

Mr. J. B. HUBRECHT, M.A., read a paper entitled "**Studies in Solar Rotation.**"

An account was given of a spectrographic determination of the solar rotation, as observed at Cambridge. Photographs had been taken showing the displacements of the absorption lines due, in accordance with Doppler's principle, to motion in the line of sight of the points on the sun's limb compared. The velocity of such a point being in maximo 2 km. per second, as determined from earlier investigations, the maximum displacement to be determined is 0.030 Ångström Unit. In order to get accurate measurements of such small wave-length differences a large dispersion is necessary. On the Cambridge plates this amounted to 1 mm. per 0.88 Å.U. The measurements were all carried out by Mr. N. Tunstall, student of Manchester University, by means of the spectro-comparator shown.

A total of 194 plates had been taken and measured. The plates, which were all obtained within one fortnight in June, 1911, gave comparisons between points situated, not, as in the earlier investigations, at the ends of solar diameters, but between points at 90° apart all round the sun. For each complete set of observations round the sun, of which there were four in all, it was possible to obtain two independent determinations of a quantity  $E$  representing the difference between the sum total of ten velocities at certain latitudes in the Northern and the sum total of ten velocities at the same latitudes in the Southern hemisphere of the sun. Of this difference, which in case of symmetry round the solar

equator should be zero, eight independent determinations were thus available, which gave for North minus South a mean of  $E = +0.540 \pm 0.006$  in km. per second. A marked difference between the rotational behaviour of the two solar hemispheres thus seems to be definitely established for the epoch of observation.

A second result claimed from these observations concerns the latitude law expressing the retardation of the revolutions away from the equator. It is impossible to fit in the present series with the usually accepted formula

$$V = (a - b\sin^2\phi)\cos\phi,$$

where the second term inside the brackets introduces the retardation. A positive third term is necessary, as in a formula

$$V = (a - b\sin^2\phi + c\sin\phi)\cos\phi$$

which, with suitable constants, agrees very well with the values of  $V$  observed at the latitudes  $\phi$ .

Possibly the fact that all the spectrograms were taken within a short interval of time is the cause of the appearance of this term. In earlier investigations, all of which extended over a much longer range of dates, the term may have been eliminated by yet unknown, more or less periodical processes regulating the velocities.

---

General Meeting, March 10th, 1914.

The President, Mr. FRANCIS NICHOLSON, F.Z.S.,  
in the Chair.

Miss EVA HIBBERT, Assoc.M.S.T., Demonstrator in Chemistry, The Municipal School of Technology, Manchester, was elected an Ordinary Member of the Society.

---



Ordinary Meeting, March 10th, 1914.

The President, Mr. FRANCIS NICHOLSON, F.Z.S.,  
in the Chair.

A vote of thanks was accorded the donors of the books upon the table. These included: "*The International Kite and Balloon Ascents*," by Ernest Gold (Geophysical Memoirs, No. 5) (4to., London, 1913), "*The Free Atmosphere in the Regions of the British Isles*," by W. H. Dines (Geophysical Memoirs, No. 6) (4to., London, 1914), and "*A comparison... Electrical Conditions... Atmosphere at Kew and Eskdalemuir*," by Gordon Dobson (Geophysical Memoirs, No. 7) (4to., London, 1914), presented by the Meteorological Office, London; and "*The Anhyseretic Magnetic Properties of Iron and Nickel, Part I*," by J. R. Ashworth (8vo., [London], 1914), presented by the author.

Mr. C. E. STROMEYER, M.Inst.C.E., drew attention to the following anagram, composed by Jablonsky, Rector of the school of Lissa, on the occasion of the return of Stanislaus, subsequently King of Poland, from his travels. His family's name was Lescinski.

|                  |                                      |
|------------------|--------------------------------------|
| DOMUS LESCINIA   | House of Lescinski,                  |
| ADES INCOLUMIS   | Uninjured art thou here.             |
| OMNIS ES LUCIDA  | Entirely radiant art thou            |
| LUCIDA SIS OMEN  | Bright must thou be.                 |
| MANE SIDUS LOCI  | Remain as an omen, star of the land. |
| SIS COLUMNA DEI  | A pillar of God.                     |
| I! SCANDE SOLIUM | Go! ascend the throne.               |

Also, he pointed out that the first two lines of a poem by J. a'Lasco read the same both backwards and forwards:

Aspice! nam raro mittit timor arma, nec ipsa,  
Si se mente reget, non tegeter Nemesis.

PROFESSOR EDMUND KNECHT, Ph.D., read a paper by himself, and Miss EVA HIBBERT, Assoc.M.S.T., entitled, "**On l-pimarinic acid from French rosin.**"

The authors have succeeded in preparing l-pimarinic acid from French rosin in considerable yield by the following process:—The rosin is dissolved by heating over a free flame with glacial acetic acid and the solution thus obtained is set aside to crystallise. The semi-crystalline mass, which separates after standing for periods varying from a week to a fortnight, is filtered from the mother liquor and oily constituents on the vacuum pump, and is purified by re-crystallising several times from glacial acetic acid and then from methyl alcohol until the melting point and optical rotation are constant. In this manner it is possible to obtain a yield of the pure acid equal to about  $12\frac{1}{2}$  per cent. of the weight of the rosin employed.

Ultimate analyses and molecular weight determinations showed that the product possesses the composition  $C_{20}H_{30}O_2$ . Its melting point is  $161^\circ C.$  and its optical rotation  $\alpha_D = -80^\circ$ . The specific gravity at  $15^\circ C.$  was found to be 1.06. Exposed to the air it is oxidised, this being accompanied by a yellowing of the crystals and a drop in the melting point and optical rotation. Exposed to oxygen in a flask at a temperature of  $80^\circ C.$ , to constancy the gas is taken up in the proportion of two atoms of oxygen to one molecular weight of the acid. The methyl ether  $C_{20}H_{29}O_2CH_3$  is a thick colourless liquid having an optical rotation  $\alpha_D = -53^\circ$ . The tribromide  $C_{20}H_{27}Br_3O_2$  is obtained by mixing in the cold solutions of bromine and of l-pimarinic acid in petroleum spirit, and was shown to be a substitution and not an addition compound; its optical activity is  $\alpha_D = 25^\circ$ . By passing nitrous fumes into the solution of l-pimarinic acid in petroleum spirit, the nitrosate  $C_{20}H_{30}O_2N_2O_4$  separates out as a crystalline mass.

When heated for several hours in an evacuated sealed tube in the vapour of boiling aniline, l-pimarinic acid loses water and yields an anhydride  $(C_{20}H_{29}O)_2O$  which resembles rosin in appearance and is optically inactive (in petroleum spirit solution).

This product when crystallised from alcohol or glacial acetic acid yields the racemic pimaric acid showing a melting point of  $158^{\circ}\text{C}$ ., and having a specific gravity at  $15^{\circ}\text{C}$ . of 1.08. It is remarkable that the racemic compound shows by cryoscopic methods (boiling point in benzene and alcohol and freezing point in benzene) a double molecular weight while the l modification behaves normally. After numerous unsuccessful attempts to resolve the racemic pimaric acid into its optical isomerides, it was found that this could be effected by means of d-tetrahydroquinaldine. The subject is being further investigated.

Mr. R. F. GWYTHER, M.A., read a paper, entitled  
"The Specification of Stress. Part IV. The Elastic Solution: the Elastic Stress relations and conditions of Stability: Struts, ties, and test-pieces."

This paper is printed in full in the *Memoirs*.

---

Special Meeting, March 18th, 1914.

The President, Mr. FRANCIS NICHOLSON, F.Z.S.,  
in the Chair.

At the Society's invitation, Professor W. H. BRAGG, M.A., F.R.S., delivered a Special Lecture on "**Crystalline Structure as revealed by X-rays.**"

---

Ordinary Meeting, March 24th, 1914.

The President, Mr. FRANCIS NICHOLSON, F.Z.S.,  
in the Chair.

A vote of thanks was accorded the donors of the books upon the table. Amongst these were: "*Elements of the History*

of the *English Language*," by U. Lindelöf (University of Washington Publications, English, I.) (12mo., Seattle, 1911), and "*The Political and Ecclesiastical Allegory of the First Book of the Faerie Queene*," by F. M. Padelford (University of Washington Publications, English, II.) (12mo., Boston, etc., n.d.), presented by the University of Washington, Seattle; and one hundred and seventy-three Theses, presented by K. Christian-Albrechts Universität, Kiel.

The PRESIDENT referred to the death of Sir JOHN MURRAY, K C.B., Sc.D., F.R.S., on March 16th. Sir John Murray had been an Honorary Member of the Society since 1894.

Four papers, on a **Faunal Survey of Rostherne Mere**, were read:—

1. **Introduction and methods.** By W. M. TATTERSALL, D.Sc., and T. A. COWARD, F.Z.S., F.E.S.
2. **Preliminary account of the Flora.** By R. S. ADAMSON, M.A., B.Sc.
3. **Vertebrata.** By T. A. COWARD, F.Z.S., F.E.S.
4. **Preliminary list of Lepidoptera.** By A. W. BOYD, M.A., F.E.S.

Nos. 1, 3 and 4 are printed in full in the *Memoirs*. No. 2 will appear later.

---

General Meeting, April 7th, 1914.

The President, Mr. FRANCIS NICHOLSON, F.Z.S.,  
in the Chair.

Mr. S. LEES, M.A., Assoc.M.S.T., Fellow of St. John's College, Cambridge, Reader in Applied Thermo-Dynamics in the Faculty of Technology, the University of Manchester, was elected an ordinary member of the Society.

---

Ordinary Meeting, April 7th, 1914.

The President, Mr. FRANCIS NICHOLSON, F.Z.S., succeeded by Professor F. E. WEISS, D.Sc., F.L.S., in the Chair.

A vote of thanks was accorded the donors of the books upon the table.

A paper, entitled "**A Preliminary Note on the Structure of Coal,**" by Mr. W. C. GRUMMITT and Dr. G. HICKLING was read by the latter.

A preliminary account was given of an investigation which promises to throw considerable light on the nature and history of coal. It was suggested that the essential constituent of coal is a homogeneous substance, red or orange in colour when thin enough to be transparent. This material under the microscope frequently shows evidence of "flow," and was doubtless a liquid vegetable decomposition product. In its purest form this material constitutes the "bright" layers of coal; with strongly developed "cleat" or cleavage. Vegetable structures are preserved in coal in two forms: (1) in a "carbonised" condition, as is found pure in "mother of coal"—this material is quite opaque even when much less than  $1\mu$  thick: (2) impregnated with the transparent material described above; spores are the most readily distinguishable parts preserved in this manner, their walls being greatly swollen by impregnation; the "bright" bands of coal also can often be seen to consist of wood or cortex impregnated with similar material, but in this case the impregnated cell-walls may so closely resemble the material filling their cavities as to be distinguishable only with difficulty, and it is probable that vegetable structures really exist in parts where they cannot on this account be distinguished at all. It is noteworthy that the material which has impregnated the spores is always much lighter in colour than that which has penetrated other vegetable tissues. It has been shown that the ash from the various coals consists largely of fibrous material which is clearly

an incombustible residue of vegetable structure. This material closely resembles the ash obtained by burning wood. It has been found possible to isolate the spores from certain coals by maceration with Schultz solution. Common coal appears to be essentially similar in character to the material formed in "coal-balls" with the difference that in place of being impregnated with carbonate of lime, the mass has been impregnated with its own decomposition products.

---

Annual General Meeting, April 28th, 1914.

The President, Mr. FRANCIS NICHOLSON, F.Z.S.,  
in the Chair.

The Annual Report of the Council and the Statement of Accounts were presented, and it was resolved:—That the Annual Report, together with the Statement of Accounts, be adopted, and that they be printed in the Society's *Proceedings*.

Mr. ARTHUR ADAMSON and Dr. WALTER MAKOWER were appointed Scrutineers of the balloting papers.

The following members were elected Officers of the Society and Members of the Council for the ensuing year:—

*President*: FRANCIS NICHOLSON, F.Z.S.

*Vice-Presidents*: FRANCIS JONES, M.Sc., F.R.S.E., F.C.S.; WILLIAM BURTON, M.A., F.C.S.; SYDNEY J. HICKSON, M.A., D.Sc., F.R.S.; G. ELLIOT SMITH, M.A., M.D., F.R.S.

*Secretaries*: R. L. TAYLOR, F.C.S., F.I.C.; GEORGE HICKLING, D.Sc., F.G.S.

*Treasurer*: W. HENRY TODD.

*Librarian*: C. L. BARNES, M.A.

*Other Members of the Council*: T. A. COWARD, F.Z.S., F.E.S.; W. W. HALDANE GEE, B.Sc., M.Sc.Tech., A.M.I.E.E.; R. F. GWYTHYR, M.A.; H. R. HASSÉ, M.A., D.Sc.; THOMAS THORP, F.R.A.S.; W. M. TATTERSALL, D.Sc.

---

Ordinary Meeting, April 28th, 1914.

The President, Mr. FRANCIS NICHOLSON, F.Z.S.,  
in the Chair.

A vote of thanks was accorded to the donors of the books upon the table. These included: "*Ethnozoology of the Tewa Indians*," by J. Henderson and J. P. Harrington (Bulletin 56) (8vo., Washington, 1914), presented by the Bureau of American Ethnology, Washington; and "*Geologic Atlas of the United States*," Folios Nos. 185, 187, 188, 189 and 190 (la. fol., Washington, 1912, 1913), presented by the United States Geological Survey, Washington.

Mr. C. I. BARNES, M.A., inaugurated a brief discussion relating to Plane trees as a cause of certain pulmonary troubles.

Mr. R. F. GWYHER read a paper entitled "**Specification of Stress. Part V. An outline of the theory of Hyper-elastic Stress.**" In this paper the author dealt with the mathematical conditions of a body from the state of exceeding the elastic limit and approaching that of rupture.

Neither experiments nor experience in engineering practice have supplied information which will aid in the mathematical treatment of the interval between the failure of complete fulfilment of Hooke's Law and the earliest stage of rupture.

In this paper the author proposes to give a survey of the mathematical conditions which obtain up to the stage when rupture is imminent.

The method is one which the author introduced in a paper read before the Society in 1895.

A paper on "**The Photographic Action of  $\alpha$ -rays,**" by Mr. H. P. WALMSLEY, M.Sc., and WALTER MAKOWER, B.A., D.Sc., was read by the latter. Dr. Makower discussed the photographic action of  $\alpha$ -particles and showed micro-photographs illustrating the path of the rays through a photographic film. Each  $\alpha$ -particles in striking a grain of silver affects that grain in

such a manner as to be capable of photographic development, and thus the track of each ray is made evident under the microscope as a dotted line in the negative.

---

Ordinary Meeting, May 12th, 1914.

The President, Mr. FRANCIS NICHOLSON, F.Z.S.,  
in the Chair.

A vote of thanks was accorded the donors of the books upon the table. Amongst these were: "*Photographic Magnitudes of Stars brighter than 9<sup>m</sup>.0 between Declination + 75° and the Pole*," (4to., London, 1913), and "*Position of the Sun's Axis, as determined from Photographs of the Sun...1874 to 1912*" (4to., London, 1913), presented by the Royal Observatory, Greenwich; and "*An Artilleryman's Diary*," by J. Lloyd Jones (Original Papers, No. 8) (8vo, n.p., 1914), presented by the Wisconsin History Commission, Wisconsin.

New exchanges have been arranged with the State University of Iowa, Iowa City (*Contributions*), and with the Washington University, St. Louis (*Studies*). The exchange with the Architekten-und Ingenieur-Verein (*Zeitschrift für Architektur und Ingenieurwesen*) has been discontinued.

Dr. J. R. ASHWORTH read a paper entitled, "**Note on the Intrinsic Field of a Magnet.**"

This paper is printed in full in the *Memoirs*.

Mr. F. R. LANKSHEAR, B.A., M.Sc., read a paper entitled, "**Quantitative Absorption Spectra, Part I. The chemical significance of absorption spectra and the methods of examining them.**"

This paper is printed in full in the *Memoirs*.

---



## MANCHESTER

## LITERARY AND PHILOSOPHICAL SOCIETY.

*Annual Report of the Council, April, 1914.*

The Society had at the beginning of the session an ordinary membership of 155. Since then seven new members have joined the Society, eleven members have resigned, and six members, Sir WILLIAM H. BAILEY, M.I.Mech E., F.R.G.S., Mr. HENRY BROGDEN, F.G.S., M.I.Mech.E., Mr. ROBERT COTTON, M.Sc., Mr. WILLIAM H. JOHNSON, B.Sc., Professor JOHN T. NICOLSON, D.Sc., and Mr. W. H. SUTCLIFFE, F.G.S., have died. There are, therefore, at the end of the session, 145 ordinary members of the Society. The Society has also lost, by death, three honorary members, viz.: Professor PAUL F. ASCHERSON, the Right Honourable The Lord AVEBURY, D.C.L., LL.D., F.R.S., and Sir JOHN MURRAY, K.C.B., LL.D., Sc.D., F.R.S. Memorial notices\* of these gentlemen will appear with this report in the *Memoirs and Proceedings*.

Twenty-nine papers have been read at the meetings during the year; eighteen shorter communications have also been made.

The Society commenced the session with a balance in hand, from all sources, of £263. 1s. 6d., made up as follows:—

|                                 |      |    |       |
|---------------------------------|------|----|-------|
| At credit of General Fund ..... | £142 | 2  | 7     |
| „ „ Wilde Endowment Fund...     | 116  | 11 | 5     |
| „ „ Joule Memorial Fund.....    | 4    | 7  | 6     |
|                                 |      |    | <hr/> |
| Balance 31st March, 1913.....   | £263 | 1  | 6     |

\* Obituary notices of Mr. W. L. Behrens, not included in the last volume of the *Memoirs*, and of Mr. Thomas Thorp, who died on June 13th, 1914, are also appended.

The balance in hand at the close of the session amounted to £548. 2s. 11d., the amounts standing at credit of the various accounts on the 31st March, 1914, being:—

|                                     |   |     |    |             |
|-------------------------------------|---|-----|----|-------------|
| At credit of General Fund.....      | £ | 31  | 11 | 4           |
| "    "    Wilde Endowment Fund...   |   | 249 | 14 | 6           |
| "    "    Joule Memorial Fund ..... |   | 266 | 17 | 1           |
|                                     |   |     |    | <hr/>       |
| Balance 31st March, 1914.....       | £ | 548 | 2  | 11          |
|                                     |   |     |    | <hr/> <hr/> |

The Wilde Endowment Fund, kept as a separate banking account, shows a balance due to the Fund of £249. 14s. 6d. in its favour, as against a balance in hand of £116. 11s. 5d. at the end of the last financial year. The receipts for the year 1913-14 again show a slight increase on those for the previous year.

The Librarian reports that during the session 955 volumes have been stamped, catalogued and pressmarked; 919 of these were serials, and 36 were separate works. 244 catalogue cards were written, 160 for serials, and 64 for separate works. The total number of volumes catalogued to date is 35,582, for which 12,413 cards have been written.

The library continues to be satisfactorily used for reference purposes. 285 volumes have been borrowed from the library during the past year. The number of books borrowed during the previous year was 238, and during 1911-12, 274.

During the year 267 volumes have been bound in 185 covers. In the previous session the corresponding numbers were 229 volumes in 192 covers.

The additions to the library for the session amounted to 896 volumes, 836 serials, and 60 separate works. The donations (exclusive of the usual exchanges) were 57 volumes and 203 dissertations; 3 volumes were purchased, in addition to those regularly subscribed for.

New exchanges have been arranged with the following:—The Cardiff Naturalists' Society (*Transactions*), Cardiff; the University of Minnesota (*Research Publications, Bulletin, etc.*), Minneapolis; The Washington University Library (*Studies*) St. Louis, Mo.; and the State University of Iowa (*Bulletin and Contributions*), Iowa, U.S.A.

The following exchanges have been discontinued:—The Society of Chemical Industry (*Journal*), London; and the Architekten-und Ingenieur-Verein (*Zeitschrift für Architektur und Ingenieurwesen*), Hanover.

The donations to the Society's Library during the session include gifts of books by the Trustees of the British Museum (Natural History), the Royal Society of London, the Committee of the British Association, the National Museum of Wales, the Meteorological Office, London, and Dr. Peter Sandiford.

The publication of the Society's *Memoirs and Proceedings* has been continued under the supervision of the Editorial Committee.

The £258 Twenty years' loan to the Manchester Corporation stock, being the residue of the Joule Memorial Fund, redeemable on 25th March, 1914, has been repaid.

Sir Thomas H. Holland, K.C.I.E., D.Sc., F.R.S., represented the Society at the 12th International Congress of Geology held in Canada in August last.

On the invitation of the Selborne Society to nominate a representative to serve on the Plant Protection Committee of that Society, Professor F. E. Weiss, D.Sc. F.L.S., was nominated as the representative of this Society.

At the Society's invitation, Professor W. H. Bragg, M.A., F.R.S., delivered a special lecture before the Society on March

18th. The title of the lecture was "Crystalline Structure as revealed by X-rays." Professor Bragg was the chief guest at the Annual Dinner, held the same evening.

The Committees appointed by the Council during the year were as follows:—

*House and Finance.*

|                    |                        |
|--------------------|------------------------|
| The PRESIDENT.     | Professor F. E. WEISS. |
| Mr. FRANCIS JONES. | Mr. W. H. TODD.        |
| Mr. C. L. BARNES.  | Dr. H. G. A. HICKLING. |
| Mr. R. L. TAYLOR.  |                        |

*Editorial.*

|                          |                          |
|--------------------------|--------------------------|
| The PRESIDENT.           | Mr. R. F. GWYTHYR.       |
| Professor S. J. HICKSON. | Mr. R. L. TAYLOR.        |
| Dr. H. G. A. HICKLING.   | The ASSISTANT SECRETARY. |

*Wilde Endowment.*

|                        |                   |
|------------------------|-------------------|
| The PRESIDENT.         | Mr. W. H. TODD.   |
| Mr. FRANCIS JONES.     | Mr. R. L. TAYLOR. |
| Dr. H. G. A. HICKLING. |                   |

*Special Library Periodical Committee.*

|                              |                          |
|------------------------------|--------------------------|
| The PRESIDENT.               | Professor F. E. WEISS.   |
| Professor S. J. HICKSON.     | Mr. C. L. BARNES.        |
| Professor W. W. HALDANE GEE. | Mr. R. F. GWYTHYR.       |
| Mr. R. L. TAYLOR.            | Dr. H. G. A. HICKLING.   |
|                              | The ASSISTANT SECRETARY. |

Professor PAUL ASCHERSON, who died on March 6th, 1913, was born in June, 1834. By his death the science of botany has lost one of the leaders of the older school of workers in the realm of floristics. Studying under such botanists as Alex. Braun, Pringsheim and Caspary, Ascherson's early progress and

enthusiasm bore its first fruit in his "Nachträgliche Bemerkungen zur Flora von Magdeburg," published in 1853, when he was but 19 years old. Six years later, in 1859, appeared his now classical work, "Flora der Provinz Brandenburg," one of the best local floras published. This work was later re-published, in 1898-9, in collaboration with his pupil and friend, Graebner, as "Flora des Nordostdeutschen Flachlande," a work which marks a distinct stage in the progressive evolution of the flora.

Ascherson's work, however, was by no means confined merely to North Germany; he travelled somewhat extensively in Europe, visiting at different periods England, Norway, France, Italy, Sardinia, Hungary, The Carpathians, Dalmatia, Greece, Turkey and Egypt. As one result of his travels he commenced, along with Graebner, his greatest work, the "Synopsis der mitteleuropäischen Flora," the first part of which appeared in 1894. This work he unfortunately did not live to see completed.

Whatever may be the verdict as to the details of this work, there can be no doubt that, for exhaustive and complete treatment, it ranks in the forefront of the great modern floras.

From 1860-76 Ascherson was assistant to the Director of the Berlin Botanic Gardens. In 1865 he was assistant in the Royal Herbarium, becoming keeper in 1871, a post he retained till 1884. In 1873 he was made Extraordinary Professor, and Honorary Professor in 1908. Professor Ascherson was elected an honorary member of this Society in 1892.

R. S. A.

By the death of Sir JOHN LUBBOCK, first LORD AVEBURY, this Society has lost one of the most remarkable of its honorary members, a man of many parts who illuminated whatever he touched. He was perhaps the finest example in his generation of that class of scientific amateurs, happily numerous in Britain, who command the respect of all by the clarity of their judgment, and lay the specialist under the deepest obligation by their breadth of view. The son of a banker, he left Eton at the early age of fourteen to make a great name in the financial world.

His early taste for scientific recreation was doubtless largely influenced by his neighbours, Sir Joseph Prestwich and Charles Darwin, as well as by his life-long friend, Sir John Evans. So, at the age of twenty-five, he became a Fellow of the Geological Society of London, and, three years later, a Fellow of the Royal Society.

In his earlier years, Lord Avebury took a special interest in the remarkable communal instincts of insects, out of which arose a long series of observations which were recorded in several volumes and papers, of which the "Ants, Bees and Wasps" is the best known. Though he never professed to be an original investigator in the field of Geology, he nevertheless followed closely the progress of research, especially in the region of physiography, and his "Scenery of Switzerland" is deservedly regarded as a classic among the works which endeavour to bring the larger problems of earth-history within the grasp of the educated public. But his contributions to Prehistoric Archaeology must always rank above all his other scientific attainments. With Prestwich and Evans he must be regarded as one of the founders of the modern study of primitive man; it was among his earliest interests, and his last literary effort was the revision of his great work on "Prehistoric Times." His work in this field was recognised by the Geological Society in 1903 by the first bestowal of the Prestwich Medal.

Lord Avebury was one of those pre-eminent men in honouring whom all learned associations delight to honour themselves. Universities, learned societies and national institutions in all parts of the world showered their distinctions upon him, and to name even the societies over which he presided would be tedious.

Though we naturally give precedence to his eminence in the world of Science, his fame was equally justified by his activity as a man of affairs. As a banker he was a recognised leader, and as a politician he unobtrusively brought about numerous reforms of a philanthropic character, notably the institution of Bank Holidays. For thirty years he was a mem-

ber of the House of Commons, representing the University of London from 1880 to 1900, in which latter year he was raised to the peerage. Among other offices of great importance, he was the first Chairman of the London County Council.

His other claims to an affectionate remembrance might all be forgotten, and his memory be yet kept green by his purely literary activities. Few prolific writers have been gifted with a more simply charming style. While this characteristic pervades all his writings, and has given pleasure to many thousands who have read his scientific contributions, millions have read his "Beauties of Nature" and "Pleasures of Life" and have felt that something sweet and pure had been added to existence. It is therefore no empty phrase that laments the great loss which humanity sustained by the death of Lord Avebury on the 28th of May, 1913, in the eightieth year of his age.

G. H.

SIR WILLIAM HENRY BAILEY was born in Salford in 1838, and attended the Manchester Grammar School for some time, until at the age of fourteen he entered the Albion Works, Salford, which had been established by his father in the year of his birth. In course of time he became manager and sole proprietor of the concern, now known as Sir W. H. Bailey & Co., Ltd. His aptitude for engineering soon declared itself, and was maintained throughout his career, as may be seen from the long list of patents, nearly a hundred in number, for which he was wholly or partly responsible between 1858 and 1912. They include instruments for indicating the speed and flow of liquids and gases, boiler fittings, lubricators for steam-engine cylinders, pressure-gauges, pumps, hydraulic rams, silencers, carburettors, speed-indicators for motors, and a great variety of devices of general utility.

Sir William was always a hard worker, and his abundant energy found an outlet in many directions outside his profession. Thus he entered the Salford Town Council in 1874, and became Mayor of the Borough in 1893. In the following year he was

knighted by Queen Victoria on board the Royal Yacht on the occasion of the opening of the Manchester Ship Canal by Her Majesty. The interests of Manchester and Salford always lay very near his heart ; thus he foresaw the enormous value of the Ship Canal, and was one of its most ardent advocates : moreover, he gave time and material aid ungrudgingly to many movements and institutions which had for their object the promotion of scientific, literary or social studies in the district. He was an old Volunteer, and presented cups for shooting to the 7th and 8th Battalions Lancashire Fusiliers, the Monmouthshire Territorial Association, and the Old Mancunian Territorial Society. In 1874 he collaborated with Prof. Tyndall in the experiments carried out off the South Foreland to determine the relative value of guns and sirens for signalling in different states of the atmosphere.

Sir William's connection with the Society began in 1888, and in 1905 he was elected President, when he initiated the custom of delivering an address from the chair on taking office. Owing to his efforts a *conversazione* was held at the Society's rooms in December, 1905, at which a large number of members and guests were present.

In 1889 he read a paper "On an old canoe found in the Irwell Valley, near Barton, with observations on pre-historic Chat Moss" (*Memoirs*, 4th ser., Vol. II.). A communication "On the topographical distribution of mechanical inventions in the County of Lancaster, and their influence on some British industries," occupies several pages of the "Proceedings" for 1901, and in the following year he exhibited a model of a switchback railway, invented and made by Richard Roberts (1789-1864). The Society is also indebted to him for a fine photograph of the statues of Dalton and Joule in the vestibule of the Town Hall.

His presence at our meetings was always welcome, and he seldom failed to recall some experience connected with the great inventors, ironmasters and engineers of the North of



England, whose achievements he had by heart, or with notable members of the Society, many of whose names are now little more than a memory. It was he, for example, who recalled a little-known branch of Sir Henry Bessemer's activities in a communication to Mr. E. F. Lange (see the latter's paper on "Bessemer, Göransson and Mushet," *Memoirs*, Vol. LVII., pp. 35-38), by quoting a letter from Bessemer to his niece, Lady Allen, in 1897, when the famous inventor was 85 years old. In this Sir Henry refers at some length to his early discoveries of the method of making the so-called gold powder, used for painting, and of embossing patterns on velvet by means of heated rollers, a secret which he kept for many years, and turned to profitable account. Such recollections were invariably enlivened by literary allusions and quotations, of which Sir William possessed a remarkable store.

He died on November 23rd, 1913, and was buried at Brooklands Cemetery, the Society being represented at the funeral by Mr. R. L. Taylor (Secretary). L. C. B.

WALTER LIONEL BEHRENS was born at Oak House, Fallowfield, Manchester, on July 15th, 1861, and died on February 15th, 1913, at his residence, the Acorns, Fallowfield.

He was the eldest son of the late Edward Behrens, of Manchester; was educated at Rugby, and was for many years a partner in the firm of S. L. Behrens and Co., of 16, Oxford Street, Manchester.

In the eighties of the last century he made a tour round the world, during which time he travelled widely in India and spent some time in Japan. It was during this visit that he commenced to collect Netsuke, Inros, Tsubas, and small lacquer pieces; his collection being finally recognised as one of the best of its kind in the world. He was one of the original members of the Japan Society in London and took great interest in its proceedings.

Mr. Behrens was for some years a member of the Museum Committee of the Manchester University. He was also on the Council of the Whitworth Institute. W. B.

HENRY BROGDEN, F.G.S., M.Inst.M.E., who died at his residence, Hale Lodge, Altrincham, on the 21st June, 1913, and was interred at Brooklands Cemetery on the 24th, was elected a member of the Society on April 2nd, 1861. He was the third son of John Brogden, of Sale, and was born in Manchester on September 30th, 1828. He was educated at King's College, London, and spent a year in the locomotive works of Messrs. Stephenson and Co, Newcastle-on-Tyne, where he developed a liking for shop work. At his home he had a very complete workshop, and throughout his life took a great interest in science. More than half a century ago he and his elder brother, Alexander Brogden, M.P. for Wednesbury from 1868 to 1885, were amongst the foremost railway contractors of the day, and as members of the firm of John Brogden and Sons, of London, Manchester, and South Wales, they carried out many important railway undertakings, not only in England, but in South America, Australia, New Zealand, Holland and other countries. One of their principal contracts in this country was the construction of the railway between Carnforth and Barrow, which they succeeded in laying after other contractors had failed to accomplish it. The line passes over a large tract of land at the head of Morecambe Bay which was reclaimed from the sea during its construction under the superintendence of Mr. Brogden. He was the engineer for the high level bridge at Stockport, for the Llynvi and Ogmore Railway in South Wales, the Tondur Iron Works and Collieries, and other important works in the "sixties and seventies."

Though Mr. Brogden was a regular attendant for many years at our meetings he never read any papers before the Society nor did he ever hold any office or serve on the Council. The only communication received from him was at a meeting of the Microscopical and Natural History Section of this Society on October 12, 1868 (*Proceedings*, 8, p. 69), where it is mentioned that "Mr. Brogden forwarded three deposits of Diatomaceae for distribution amongst the members, viz., from the Galtee

Mountains, Ireland, collected in 1868; from Levers Water, Coniston Old Man, collected in 1856; and from a stream, near Half-Moon Bay, near Carrick-a-Rede, Antrim, July, 1861."

Mr. Brogden was not the kind of man who makes history; retiring and unobtrusive he filled his life with all sorts of hobbies, scientific and other, which made him with his varied knowledge and experiences a valued friend to those who had the pleasure of his acquaintance.

F. N.

ROBERT COTTON was a promising member of the Society whose untimely death was deeply deplored by all who knew him. He entered the University of Manchester in 1902 and graduated with Honours in Engineering in 1905. After three years in practice as a civil engineer he returned to the University as Demonstrator in the Engineering Department, receiving at the same time the degree of Master of Science. On the University Staff he served for four years, and was then awarded the Vulcan Fellowship for Research, which work he was about to take up when his career was so suddenly closed.

In the University, Mr. Cotton was regarded with esteem and affection by Staff and Students alike. Engaging and courteous in manner, vivacious to a degree, his presence was always welcome and desired. He entered with unusual fulness into the social life of the institution, being for many years a moving spirit in the Engineering Society and Geologists' Association. The Officers' Training Corps, in which he became a Lieutenant, was no less indebted to him. His buoyancy of character might have misled those whose acquaintance was brief to under-estimate his true intellectual worth; those who knew him better were well aware of his true keenness as a student, both in his own field of Engineering and also in Geology, which was his hobby. Though his brief membership of this Society doubtless prevented many of his fellow-members from discovering his value, all will appreciate the real loss which they sustained by his death, on April 11th, 1913, at the early age of twenty-seven.

G. H.

By the death of Mr. WILLIAM HENRY JOHNSON, B.Sc., of Woodleigh, Altrincham, on February 19th, 1914, the Society lost one of its oldest members. Elected an ordinary member in 1870, he attended the meetings of the Society with great regularity for many years, and took an active interest in its welfare. From 1881 to 1892 and from 1899 to 1900 he was a Member of the Council: and for two years, 1897 to 1899, he held the office of Vice-President.

Mr. Johnson's communications at the Society's Meetings were about nineteen in number: they included eight papers and eleven smaller communications and exhibits. His first paper, entitled "On the Influence of Acids on Iron and Steel," was read on March 4th, 1873, appearing in the *Proceedings*, vol. xii.; and most of his communications dealt with the properties of iron and steel.

At the time of his death Mr. Johnson, who for nearly half a century had been well known in commercial life, was managing director of a well known city firm. He was also a Governor of the Manchester Grammar School: and a Vice-President of the Institute of Metals.

He died in his sixty-fifth year at his home at Altrincham.

R. F. H.

SIR JOHN MURRAY, K.C.B., LL.D., F.R.S.—John Murray was born at Coburg, Ontario, on March 3rd, 1841, the third son of Robert Murray, who had emigrated to Canada seven years before. He came to England as a boy of sixteen and completed his education at the High School, Stirling, and the University of Edinburgh. Although a zealous and successful student, he could never be induced to confine his attention to any specified curriculum, but worked at various branches of knowledge as they in turn appealed to him. One consequence of this independence was that, though he studied at the University for twelve years, he never took a degree; another was that he had a thoroughly practical first-hand acquaintance with many branches of laboratory work.

In 1872 occurred an event which determined the whole course of his future life: the famous "Challenger" expedition was equipped and the ship sailed on her voyage of deep-sea exploration with Professor Wyville Thomson as chief of the scientific staff and John Murray as one of the naturalists. Thenceforward the furtherance of the study of oceanography became the main purpose of his life.

During the voyage he made numerous observations on pelagic organisms, which were collected by the systematic use of tow-nets, but he soon perceived that important and far-reaching results were likely to be obtained by a careful examination of the materials forming the bed of the ocean at great depths. This work led him to an investigation of the formation of coral reefs and islands and to the theory which still bears his name, and which offers an explanation of the formation of atolls in places where the Darwinian theory based upon subsidence of the ocean-bed is not applicable.

Here reference must be made to a great service he rendered to the expedition by undertaking the unromantic but very necessary task of superintending the packing of the enormous collections made during the cruise and dispatched home at intervals from the various ports of call. The packages were all consigned to the University of Edinburgh, and, except for the renewal of spirit which had evaporated, remained untouched until Murray's return at the end of four years. Then began the work of sorting and classifying the spoils and their distribution to the specialists who were to undertake their description.

In 1881 Murray succeeded Sir Wyville Thomson as head of the editorial department connected with the publication of the "Challenger" Reports, and under his superintendence the series of fifty ponderous tomes containing the scientific results of the cruise was completed. Indeed, the concluding volumes were issued at his expense, for the Treasury grant for publication was exhausted before the work was finished. The work was to him a labour of love, and he spared no pains to make

the presentment of the results worthy of their scientific importance. He claimed to be the only living man who had read the whole of the 29,000 and odd pages, and it is unlikely that any one will desire to emulate him in this achievement.

He was part author of the "Narrative of the Cruise," and contributed the "Report on the Deep-sea Deposits," in collaboration with his friend the late Abbé Renard. In this he stoutly maintained the theory of the permanence of ocean basins, first propounded by Dana.

His interest in oceanography did not cease with the work in the "Challenger" expedition; he founded marine laboratories at Granton, on the Firth of Forth, and at Millport, on the Firth of Clyde, made expeditions to the Farøe Channel in the "Knight Errant" and "Triton," and more recently undertook a voyage with his friend Dr. Johan Hjort in the Norwegian fishing steamer "Michael Sars," himself defraying the cost of the cruise. The results were published in a volume entitled, "The Depths of the Ocean" (1912).

In 1898, in collaboration with Mr. Fred Pullar, he undertook a bathymetrical survey of the fresh-water lochs of Scotland, and continued the work on the death of his friend as a memorial to him, his father, Mr. Laurence Pullar, contributing towards the expenses.

Sir John Murray was also one of the promoters of the Ben Nevis Observatory and took a leading part in the scientific investigation of Christmas Island, and became chairman of a company which exploited its rich phosphatic deposits with great success.

As might be expected, Murray's distinguished services to science were recognised by numerous authorities both at home and abroad. He was created K.C.B. in 1898 and received the Royal Prussian Order "Pour le Mérite" and the Grand Cross of the Norwegian Order of St. Olav, as well as numerous medals of learned societies and university degrees.

In 1889 Sir John Murray married Isabel, only daughter of

the late Thomas Henderson, of Glasgow. Characteristically his eldest son was christened "John Challenger," and he called his house near Edinburgh, "Challenger Lodge." Here it was his delight to entertain his friends and scientific colleagues and to enjoy discussing not merely problems of oceanography, but practically all things "dreamt of in our philosophy," for he had read widely and thought much. Despite his three and seventy years he was full of energy and of schemes for future work when on the 16th March, 1914, a motor accident ended in a moment his life of strenuous activity.

The world has lost a great scientist and a sound, practical organiser, but the memory in the hearts of those who knew him and worked with him is that of a man endowed with a deep-seated love of truth and of science for its own sake, of a loyal comrade who unflinchingly, not to say brutally, told his friends just what he thought of them to their faces, and never spoke ill of them behind their backs; of a considerate chief and a loyal comrade, whose roughness of manner was only skin-deep, and who could always be depended on for sympathy and help in time of need.

W. E. H.

Professor J. T. NICOLSON.\*—The early death of Dr. J. T. Nicolson, professor of mechanical engineering in the Manchester School of Technology and in the University of Manchester, will be much regretted by a wide circle of friends. His health during the previous six months had given serious cause for anxiety, but had improved sufficiently to allow him to return to his duties. There followed a sudden relapse, and he died at Macclesfield on May 27th after a brief illness.

Prof. Nicolson was born at Amble, in Northumberland, in 1860, and received his early education at Watson's College, Edinburgh. He was then apprenticed to Hawthorne Leslie and Co., Newcastle-on-Tyne. From there he gained a Whit-

\*Reprinted in part from an article in "*Nature*," June 5th, 1913.

worth scholarship and entered Edinburgh University, where he graduated in 1889, obtaining the D.Sc. degree some years later. After graduation he spent two years in Charlottenburg, where he investigated the strength of materials under Prof. Martens. After holding the position of assistant-lecturer in engineering in the University of Cambridge, he was appointed in 1892 professor of mechanical engineering in McGill University, Montreal. He took there an active part in the equipment of the engineering department and in arranging the courses of instruction for students.

His tenure of the chair in McGill University was marked by several important investigations. He designed and constructed for F. D. Adams, Professor of Geology in the University, special apparatus for submitting specimens of rocks and minerals to the highest obtainable pressure for long intervals of time. This combination of the engineer with the geologist resulted in notable advances to our knowledge of the flow of rocks under great pressures and varying temperatures. The apparatus designed by Professor Nicolson proved very serviceable in a number of later researches along similar lines made by Professor Adams. When Professor Callendar was appointed Professor of Physics in McGill University he undertook with him an investigation on the valve-leakage of the steam on the surface of condensers. This difficult and important investigation was published in detail, and led to the award of the Telford premium to the authors.

At the time of the building of the School of Technology in Manchester, Mr. J. H. Reynolds travelled to Canada and America to examine corresponding institutions in those countries. He met Professor Nicolson in Montreal and was so impressed with his energy and ability that he was selected in 1899 to take charge of the Engineering Department of the newly opened School of Technology. Professor Nicolson was largely responsible for the whole engineering equipment of that institution, an equipment which in variety and extent is even now unsurpassed in this country. When degree courses were instituted in the



School of Technology in connection with the University of Manchester he was appointed the first professor of Mechanical Engineering, a position which he held until his death.

Although the routine duties of his Chair occupied a large amount of his time, Professor Nicolson's energy led him to undertake a number of important and extensive original investigations. He made detailed experiments on rapid-cutting steels, in which he showed the relations between the cut and speed and the durability. The results of these investigations were published as a report by the Manchester Association of Engineers in 1903, and were well received by the engineering profession. As was characteristic of Prof. Nicolson, he immediately applied the experimental results to the improvement and design of machine tools.

During the last few years of his life he took up the question of the transfer of heat to boilers. The late Prof. Osborne Reynolds had predicted in 1874 on theoretical grounds that the rate of transfer of heat from a gas or fluid to a solid surface should increase with the velocity of movement. This was confirmed for fluids by the experiments of Dr. Stanton in 1897. Prof. Nicolson, in an elaborate series of experiments, showed that the same result held for gases. He then applied this idea to the design of boilers and condensers, the essential point being that the heated gases were driven at a high speed through the tubes of the boiler, the water circulating in the opposite direction. As the result of an extended trial of a 60-h.p. boiler over sixty days, it was found that the efficiency of such a combination was considerably greater than that of the ordinary boiler. There has been much difference of opinion among engineers as to the practicability of this idea, but Prof. Nicolson himself had the strongest belief in the greater overall efficiency to be obtained by his methods.

The training of Prof. Nicolson fitted him admirably to fill the position of a professor of engineering, for he had not only a wide scientific outlook, but took a keen interest in the practical side of his profession. This is shown by the promptness with

which he applied the results of his scientific investigations to the improvement of engineering practice. He was a man of strong opinions on engineering questions, and vigorously supported his opinions when attacked. His personal integrity, straightforward character, and sympathy with scientific difficulties endeared him to his colleagues, while his vigorous personality and ability as a teacher made a strong and lasting impression on all his students. Owing to his increasing deafness he was unable in recent years to take that active part in administrative matters for which his wide outlook well fitted him. His premature death is a great loss to science, and will be much regretted, not only by his colleagues both in Manchester and Montreal, but by a wide circle of friends.

E. R.

WILLIAM HENRY SUTCLIFFE, born at Ashton in 1855, was educated at the Manchester Grammar School and subsequently attended classes in Geology under Professor Boyd Dawkins at the Owens College. Though he had to devote his energies to an industrial career, in which he attained a distinguished position as the successful manager of a large Cotton Mill in Littleborough, he always retained his early interest in geological and archæological pursuits and remained a hard worker and keen student of both branches of science. His holidays were usually devoted to scientific quests, and the collections of the Manchester Museum and of the Grammar School were frequently enriched by generous gifts of some of his most valuable finds, foremost among which may be mentioned the superb specimen of *Plesiosaurus* from Whitby, now in the Manchester Museum. He will always be remembered by palæobotanists for the generous way in which on more than one occasion, he opened out the disused coal mine close to his mill at Shore, to provide a new store of valuable coal balls containing beautifully preserved plant-remains. These yielded numerous forms new to science, several of which, such as *Sutcliffia*, bear his name; but with innate modesty he asked his palæobotanical

friends that they should in future use the name of Shore and not his own for the designation of new species. His interest in archæology centred largely in the study of prehistoric remains. He had an extensive collection of flint implements and had contributed several important papers on the "pigmy flints," underlying the peat of the hills near Rochdale. He was also greatly interested in prehistoric anthropology, and his last paper read before the Society in 1913, dealt critically and exhaustively with some modern tendencies in prehistoric anthropology.

A man of active and decisive temperament, he proved himself a warm friend of all engaged in kindred pursuits and had obtained a prominent position among Lancashire naturalists. By his death in August, 1913, the Society has lost a valuable and energetic member.

F. E. W.

THOMAS THORP, F.R.A.S., long an active member of the Society, died at Prestatyn on the 13th June, 1914. His loss will be keenly regretted by all who knew him, not only on account of the numerous valuable and interesting discoveries he made and of the ingenious instruments he invented, but still more on account of his unassuming and genial manner to all with whom he came into contact, and his readiness to explain and to make suggestions on any subject in which his wide knowledge could be of any assistance. He was born at Whitefield on October 26th, 1850, was educated at the Manchester Grammar School, and afterwards articled to Messrs. Maycock and Bell, architects. Mechanics and mechanical engineering, however, soon captivated his interest and for over thirty years he made this field his profession. His interests were not, however, confined to his daily work, but extended to scientific pursuits, particularly in relation to the sciences of light and astronomy, and he devoted his inventive abilities (which he possessed in a remarkable degree) to improving and devising new instruments for the advancement of those sciences.

He became a member of this Society in 1896, was a member of the Council (except for one year) from 1902 to 1912,

was Vice-President from 1908 to 1911, and was requested to accept nomination for the Presidency, but declined.

During his period of membership he contributed papers on "A Mechanical Device for the Solution of Problems in Refraction and Polarization" (1897), "Grating Films and their application to Colour Photography" (1899), and "On the production of Polished Metallic Surfaces having the properties of Japanese 'Magic Mirrors'" (1903): but it was perhaps more for his numerous and valuable short communications, which he so frequently made, and the instruments he exhibited at the meetings of the Society, that he was so highly esteemed by his fellow-members. Amongst his short communications may be mentioned: "On a Method of Producing a Spectrum-like Band from a Bolometric Curve" (1900), "On a Method of Silvering Diffraction Films" (1900), "On an Instrument designed to yield a pure Monochromatic Image of the Sun" (1901), "On Shadow Bands" (1905), "Description of a Method of Silvering Transparent Grating Replicas" (1909), and "A New Method for Testing the Curvature of Parabolic Mirrors" (1911). His exhibits, which were perhaps even more interesting, were (*inter alia*) "Diffraction Grating on Speculum Metal" (1896), "Copies of Diffraction Gratings on Celluloid Films" (1898), "Apparatus showing Photographs in Natural Colours by the aid of Gratings" (1899), "An Apparatus for facilitating the Sighting of a Gun" (1903), "A new Direct-vision Spectroscope" (1905), "A new form of Spring having a Constant Tension" (1908), "A Silvered Concave Grating" (1909) (presented to the Society), and "Celloidine Castings of Gratings" (1913).

In 1901 he was awarded the Wilde premium for his paper, "Grating Films and their application to Colour Photography" and other communications to the Society.

While actively engaged in his professional duties he applied his inventive faculties in various directions, particularly with respect to scientific apparatus and gas-works appliances. He was the patentee of several dozen inventions, all of them

ingenious, those of more general interest being the Penny-in-the-Slot gas meter, the Push Tap for water, important improvements in pneumatic tools, Rotary and Discount gas meters, gas lamps, colour photography, etc., and at the time of his death he was engaged in perfecting a new cinematograph screen.

He was a Fellow of the Royal Astronomical Society, and Vice-President of the Manchester Astronomical Society. Interested in all branches of physics and astronomy, he kept in touch with the leading workers in different countries. He accompanied the solar eclipse expeditions to Algiers and Burgos, important results being obtained by his special instruments. He was the possessor of several fine telescopes, the best of which will probably be offered to some educational authority in the neighbourhood. Perhaps his best contribution to the scientific world was the "Thorp Transparent Replica Diffraction Grating," referred to above, these replicas enabling many institutions and private persons to procure gratings of high resolving power at a trivial cost, though the original gratings could rarely be obtained, even by those who could afford to defray the cost of their purchase. With characteristic generosity he did not patent his method of production, but published it to the world and supplied hundreds at nominal prices. Invaluable for solar, stellar and chemical work, it may be mentioned that the grating is a thin film of celluloid material having upon its surface parallel lines 14,500 to the inch (in the replicas of Rowland's gratings). He was the recipient of several gold and other medals, and received awards at the Franco-British and St. Louis Exhibitions.

His generosity and kindness of heart, as well as his versatility, were well known to all members of the Society, and his loss will be keenly felt, particularly by regular attenders at the Society's meetings. His name will go down to posterity as no unworthy member of that fine school of non-professional scientific investigators, with Dalton at its head, of whom Manchester may be justly proud, and through whom this Society has gained renown throughout the world.

W. H. T.

## MANCHESTER LITERARY AND

W. Henry Todd, Treasurer, in Account with

Dr.

|  | £   | s. | d. | £   | s. | d.     |
|--|-----|----|----|-----|----|--------|
| To Balance, 1st April, 1913 .. .. .  |     |    |    | 146 | 10 |        |
| To Members' Subscriptions:—  |     |    |    |     |    |        |
| Quarter Subscription, 1913-14, 1 at £0 10s. 6d. .. .. .                      | 0   | 10 | 6  |     |    |        |
| Half Subscriptions, 1910-11, 1 at £1. 1s. od. .. .. .                        | 1   | 1  | 0  |     |    |        |
| " 1911-12, 1 " " .. .. .   | 1   | 1  | 0  |     |    |        |
| " 1912-13, 1 " " .. .. .   | 1   | 1  | 0  |     |    |        |
| " 1913-14, 14 " " .. .. .  | 14  | 14 | 0  |     |    |        |
| Subscriptions:—  |     |    |    |     |    |        |
| 1909-10, 1 " £2. 2s. od. .. .. .   | 2   | 2  | 0  |     |    |        |
| " 1910-11, 2 " " .. .. .   | 4   | 4  | 0  |     |    |        |
| " 1911-12, 4 " " .. .. .   | 8   | 8  | 0  |     |    |        |
| " 1912-13, 13 " " .. .. .  | 27  | 0  | 0  |     |    |        |
| " 1913-14, 104 " " .. .. .   | 218 | 8  | 0  |     |    |        |
| To Transfers from the Wilde Endowment Fund .. .. .                           |     |    |    |     |    | 278 15 |
| To Sale of Publications .. .. .  |     |    |    |     |    | 32 0   |
| To Sale of Catalogue .. .. .   |     |    |    |     |    | 21 19  |
| To Dividends:—   |     |    |    |     |    | 0 2    |
| Natural History Fund .. .. .   | 57  | 13 | 6  |     |    |        |
| Joule Memorial Fund .. .. .  | 14  | 5  | 9  |     |    |        |
| To Income Tax Refunded:—   |     |    |    |     |    | 71 19  |
| Natural History Fund .. .. .   | 3   | 11 | 6  |     |    |        |
| Joule Memorial Fund .. .. .  | 0   | 13 | 10 |     |    |        |
| Wilde Endowment Fund .. .. .   | 21  | 5  | 10 |     |    |        |
| To National Health Insurance Act deductions .. .. .                          |     |    |    |     |    | 25 11  |
| To E. F. Lange, reprints, binding, etc. .. .. .                              |     |    |    |     |    | 2 7    |
| To F. Howles, replacing lost book .. .. .                                    |     |    |    |     |    | 24 14  |
| To £258 Loan to Manchester Corporation, redeemed on March 25th, 1914 .. .. . |     |    |    |     |    | 0 5    |
|  |     |    |    |     |    | 258 0  |

£912 5

## NATURAL HISTO

|  |    |    |    |  |  |  |
|--|----|----|----|--|--|--|
| To Dividends on £1,225 Great Western Railway Company's Stock .. .. . | 57 | 13 | 6  |  |  |  |
| To Remission of Income Tax, 1913 .. .. .                             | 3  | 11 | 6  |  |  |  |
| To Balance against this Fund, 1st April, 1914 .. .. .                | 33 | 11 | 11 |  |  |  |

£95 0

## JOULE MEMORI

|  | £   | s. | d. | £ | s. | d. |
|--|-----|----|----|---|----|----|
| To Balance, 1st April, 1913 .. .. .  |     |    |    | 4 | 7  |    |
| To Dividends on £258 Loan to Manchester Corporation .. .. .                  | 7   |    |    |   |    |    |
| To Dividends on £100 East India Railway Company's 4% Annuity Stock .. .. .   | 6   | 11 |    |   |    |    |
| To £258 Loan to Manchester Corporation, redeemed on March 25th, 1914 .. .. . | 258 |    |    |   |    |    |
| To Remission of Income Tax, 1913 .. .. .                                     | 0   | 1  |    |   |    |    |

£277

## WILDE ENDOWME

|  |     |   |  |  |  |  |
|--|-----|---|--|--|--|--|
| To Balance, 1st April, 1913 .. .. .  | 116 | 1 |  |  |  |  |
| To Dividends on £7,500 Gas Light and Coke Company's Ordinary Stock .. .. . | 343 | 1 |  |  |  |  |
| To Remission of Income Tax, 1913 .. .. .                                   | 21  |   |  |  |  |  |
| To Bank Interest .. .. .   | 2   | 1 |  |  |  |  |

£484

PHILOSOPHICAL SOCIETY.

Statement, from 1st April, 1913, to 31st March, 1914.

Cr.

|  | £   | s. | d. | £           | s.       | d.       |
|--|-----|----|----|-------------|----------|----------|
| Charges on Property :—   |     |    |    |             |          |          |
| Chief Rent (Income Tax deducted) .. .. .   | 12  | 3  | 4  |             |          |          |
| Income Tax .. .. .   | 0   | 15 | 0  |             |          |          |
| Insurance against Fire .. .. .   | 11  | 0  | 0  |             |          |          |
| House Expenditure :—   |     |    |    | 23          | 18       | 4        |
| Coals, Gas, Electric Light, Water, &c. .. .. .   | 36  | 18 | 9  |             |          |          |
| Tea, Coffee, &c., at Meetings .. .. .  | 12  | 10 | 0  |             |          |          |
| Cleaning, Sweeping Chimneys, &c. .. .. .   | 3   | 10 | 8½ |             |          |          |
| Replacements of mantles, crockery, dusters, ironware, etc. .. .. .                           | 5   | 0  | 1½ |             |          |          |
| Whitewashing, repairs, etc. .. .. .  | 3   | 1  | 9  |             |          |          |
| Arc Lamp .. .. .   | 4   | 4  | 0  |             |          |          |
| Administrative Charges :—  |     |    |    | 65          | 14       | 4        |
| Housekeeper .. .. .  | 65  | 0  | 0  |             |          |          |
| Postages, and Carriage of Parcels and of "Memoirs" .. .. .                                   | 32  | 10 | 1½ |             |          |          |
| Stationery, Cheques, Receipts, and Engrossing .. .. .  | 10  | 11 | 4  |             |          |          |
| Printing Circulars, Reports, &c. .. .. .   | 16  | 0  | 7  |             |          |          |
| Extra attendance at Meetings, and during housekeeper's holidays .. .. .                      | 3   | 13 | 0  |             |          |          |
| Insurance against Liability .. .. .  | 0   | 12 | 0  |             |          |          |
| National Health Insurance Stamps .. .. .   | 4   | 6  | 8  |             |          |          |
| Miscellaneous Expenses .. .. .   | 1   | 17 | 9½ |             |          |          |
|  |     |    |    | 135         | 0        | 0        |
| Publishing :—  |     |    |    |             |          |          |
| Printing "Memoirs and Proceedings" .. .. .   | 203 | 16 | 8  |             |          |          |
| Illustrations for "Memoirs" (except Nat. Hist. papers) .. .. .                               | 17  | 17 | 3  |             |          |          |
|  |     |    |    | 221         | 13       | 11       |
| Library :—   |     |    |    |             |          |          |
| Books and Periodicals (except those charged to Natural History Fund) .. .. .                 | 42  | 4  | 4  |             |          |          |
| Periodicals formerly subscribed for by the Microscopical and Natural History Section .. .. . | 3   | 7  | 6  |             |          |          |
|  |     |    |    | 45          | 11       | 10       |
| Natural History Fund :—  |     |    |    |             |          |          |
| Items shown in the Balance Sheet of this Fund below) .. .. .                                 |     |    |    | 90          | 2        | 3        |
| Moule Memorial Fund :—   |     |    |    |             |          |          |
| Item shown in the Balance Sheet of this Fund below) .. .. .                                  |     |    |    | 10          | 10       | 0        |
| Wilde Endowment Fund (Income Tax refunded) .. .. .   |     |    |    | 21          | 5        | 10       |
| Balance at Williams Deacon's Bank, 1st April, 1914 .. .. .                                   | 288 | 8  | 5  |             |          |          |
| "    "    in Treasurer's hands .. .. .   | 10  | 0  | 0  |             |          |          |
|  |     |    |    | 298         | 8        | 5        |
|  |     |    |    | <u>£912</u> | <u>5</u> | <u>5</u> |

FUND, 1913—1914. (Included in the General Account, above.)

|   | £          | s.       | d.       |
|---|------------|----------|----------|
| Balance against this Fund, 1st April, 1913 .. .. .          | 4          | 18       | 2        |
| Natural History Periodicals .. .. .                         | 00         | 8        | 3        |
| Illustrations for papers on Nat. Hist. in "Memoirs" .. .. . | 25         | 0        | 0        |
| Binding Periodicals .. .. .                                 | 4          | 5        | 0        |
|   | <u>£95</u> | <u>0</u> | <u>5</u> |

FUND, 1913—1914. (Included in the General Account, above.)

|                                  | £           | s.       | d.       |
|----------------------------------|-------------|----------|----------|
| Special Lecture .. .. .          | 10          | 10       | 0        |
| Balance, 1st April, 1914 .. .. . | 266         | 17       | 1        |
|                                  | <u>£277</u> | <u>7</u> | <u>1</u> |

FUND, 1913—1914.

|   | £           | s.       | d.       |
|---|-------------|----------|----------|
| Assistant Secretary's Salary .. .. .              | 127         | 10       | 0        |
| Maintenance of Society's Library :—               |             |          |          |
| Binding and Repairing Books .. .. .               | 24          | 17       | 10       |
| Transfers to Society's Funds .. .. .              | 82          | 0        | 0        |
| Cheque Book .. .. .                               | 0           | 2        | 0        |
| Balance at District Bank, 1st April, 1914 .. .. . | 249         | 14       | 0        |
|   | <u>£484</u> | <u>5</u> | <u>4</u> |

NOTE.—The Treasurer's Accounts of the Session 1913-1914 have been endorsed as follows :

April 8th, 1914.                      Audited and found correct.

We have also seen, at this date, the certificates of the following Stocks held in the name of the Society :—£1,225 Great Western Railway Company 5% Consolidated Preference Stock, Nos. 12,293, 12,294, and 12,323 ; £7,500 Gas Light and Coke Company Ordinary Stock (No. 8/1960) ; £100 East India Railway Company's 4% Annuity Stock (No. 4032) ; and the deeds of the Natural History Fund, of the Wilde Endowment Fund, those conveying the land on which the Society's premises stand, and the Declarations of Trust.

Leases and Conveyances dated as follow :—

22nd Sept., 1797.

23rd Sept., 1797.

25th Dec., 1799.

” ” ”

22nd Dec., 1820.

23rd Dec., 1820.

Declarations of Trust :—

24th June, 1801.

23rd Dec., 1820.

8th Jan., 1878.

Appointment of New Trustees :—

30th April, 1851.

We have also verified the balances of the various accounts with the bankers' pass books.

(Signed) { A. ADAMSON.  
                  D. THODAY.



THE COUNCIL  
AND MEMBERS  
OF THE  
MANCHESTER  
LITERARY AND PHILOSOPHICAL SOCIETY.

---

*(Corrected to October 10th, 1914.)*

---

**President.**

FRANCIS NICHOLSON, F.Z.S.

**Vice-Presidents.**

FRANCIS JONES, M.Sc., F.R.S.E., F.C.S.  
WILLIAM BURTON, M.A., F.C.S.  
SYDNEY J. HICKSON, M.A., D.Sc., F.R.S.  
G. ELLIOT SMITH, M.A., M.D., F.R.S.

**Secretaries.**

R. L. TAYLOR, F.C.S., F.I.C.  
GEORGE HICKLING, D.Sc., F.G.S.

**Treasurer.**

W. HENRY TODD.

**Librarian.**

C. L. BARNES, M.A.

**Other Members of the Council.**

T. A. COWARD, F.Z.S., F.E.S.  
W. W. HALDANE GEE, B.Sc., M.Sc.Tech., A.M.I.E.E.  
R. F. GWYTHIER, M.A.  
H. R. HASSÉ, M.A., D.Sc.  
W. M. TATTERSALL, D.Sc.

[One vacancy.]

---

**Assistant Secretary and Librarian.**

R. F. HINSON.

## ORDINARY MEMBERS.

*Date of Election.*

- 1911, April 4. Adamson, Arthur, M.Sc.Tech., A.R.C.S., Lecturer in Physics in the Municipal School of Technology, Manchester. *Municipal School of Technology, Sackville Street, Manchester.*
- 1901, Dec. 10. Adamson, Harold. *Oaklands Cottage, Godley, near Manchester.*
- 1912, Oct. 15. Adamson, R. Stephen, M.A., B.Sc., Lecturer in Botany in the Victoria University of Manchester. *The University, Manchester.*
- 1870, Dec. 13. Angell, John, F.C.S., F.I.C. 6, *Beacons-Field, Derby Road, Withington, Manchester.*
- 1865, Nov. 14. Bailey, Charles, M.Sc., F.L.S. *Haymesgarth, Cleeve Hill, S.O., Gloucestershire.*
- 1895, Jan. 8. Barnes, Charles L., M.A. 151, *Plymouth Grove, Manchester.*
- 1903, Oct. 20. Barnes, Jonathan, F.G.S. *South Cliff House, 301, Great Cloves Street, Higher Broughton, Manchester.*
- 1910, Oct. 18. Beattie, Robert, D.Sc., M.I.E.E., Professor of Electro-technics in the Victoria University of Manchester. *The University, Manchester.*
- 1895, Mar. 5. Behrens, Gustav. *Holly Royde, Withington, Manchester.*
- 1868, Dec. 15. Bickham, Spencer H., F.L.S. *Underdown, Ledbury.*
- 1914, Feb. 10. Boyd, A. W., M.A., F.E.S. *The Alton, Altrincham, Cheshire.*
- 1875, Nov. 16. Boyd, John. *Barton House, 11, Dunsbury Park, Didsbury, Manchester.*
- 1889, Oct. 15. Bradley, Nathaniel, F.C.S. *Sunnyside, Whalley Range, Manchester.*
- 1912, Oct. 15. Brierley, W.B., M.Sc., Lecturer in Economic Botany in the Victoria University of Manchester. *The University, Manchester.*
- 1889, April 16. Brooks, Samuel Herbert. *Slale House, Levenshulme, Manchester.*
- 1910, Nov. 1. Broome, James S., Science Teacher in the Salford Secondary School. 18, *Seedley Park Road, Pendleton, Manchester.*
- 1886, April 6. Brown, Alfred, M.A., M.D. *Beech Hill, Hale, Cheshire.*

## Ordinary Members.

iv

### *Date of Election*

- 1913, Dec. 2. Brown, T. Graham, M.D., B.Sc., Lecturer in Experimental Physiology in the Victoria University of Manchester. *The University, Manchester.*
- 1889, Jan. 8. Brownell, Thomas William, F.R.A.S. 64, *Upper Brook Street, Manchester.*
- 1889, Oct. 15. Budenberg, C. F., M.Sc., M.I.Mech.E. *Bowdon Lane, Marple, Cheshire.*
- 1911, Jan. 10. Burt, Frank Playfair, B.Sc. (Lond.), D.Sc. (Bristol), Senior Lecturer in Chemistry in the Victoria University of Manchester. 15, *Oak Road, Withington, Manchester.*
- 1906, Feb. 27. Burton, Joseph, A.R.C.S. Dublin. *Tile Works, Clifton Junction, near Manchester.*
- 1894, Nov. 13. Burton, William, M.A., F.C.S. *The Hollies, Clifton Junction, near Manchester.*
- 1911, Oct. 31. Butterworth, Charles F. *Waterloo, Poynton, Cheshire.*
- 1904, Oct. 18. Campion, George Goring, L.D.S. 264, *Oxford Street, Manchester.*
- 1899, Feb. 7. Chapman, D. L., M.A., F.R.S., Fellow and Tutor of Jesus College, Oxford. *Jesus College, Oxford.*
- 1901 Nov. 26. Chevalier, Reginald C., M.A., Mathematical Master at the Manchester Grammar School. 3, *Fort Road, Sedgley Park, Prestwich, Manchester.*
- 1907, Nov. 26. Clayton, Robert Henry, B.Sc., Chemist. 1, *Parkfield Road, Didsbury, Manchester.*
- 1911, May 9. Cook, Gilbert, M.Sc., A.M.Inst.C.E., Vulcan Research Fellow in Engineering in University of Manchester. 8, *Clarendon Road, Garston, Liverpool.*
- 1903, Oct. 20. Core, William Hamilton, M.Sc. *Groombridge House, Withington, Manchester.*
- 1906, Oct. 30. Coward, H. F., D.Sc., Chief Lecturer in Chemistry in the Municipal School of Technology, Manchester. *Municipal School of Technology, Sackville Street, Manchester,* and 216, *Plymouth Grove, Manchester.*
- 1906, Nov. 27. Coward, Thomas Alfred, F.Z.S., F.E.S. *Brentwood, Bowdon, Cheshire.*
- 1908, Nov. 3. Cramp, William, M.Sc.Tech., M.I.E.E., Consulting Engineer. 33, *Brace-nose Street, Manchester.*
- 1910, Oct. 4. Crewe, F. H., Assistant Science Master in the Central High School for Boys, Whitworth Street. *Glengarth, Woodford Road, Bramhall.*

*Date of Election.*

- 1911, April 4. Darwin, C. G., B.A., Lecturer at Christ's College, Cambridge. *Christ's College, Cambridge.*
- 1895, April 9. Dawkins, W. Boyd, M.A., D.Sc., F.R.S., Honorary Professor of Geology in the Victoria University of Manchester. *Fallowfield House, Fallowfield, Manchester.*
- 1894, Mar. 6. Delépine, A. Sheridan, M.B., B.Sc., Professor of Pathology in the Victoria University of Manchester. *Public Health Laboratory, York Place, Manchester.*
- 1887, Feb. 8. Dixon, Harold Bailly, M.A., Ph.D., M.Sc., F.R.S., F.C.S., Professor of Chemistry in the Victoria University of Manchester. *The University, Manchester.*
- 1906, Oct. 30. Edgar, E. C., D.Sc., Senior Lecturer in Chemistry in the Victoria University of Manchester. *The University, Manchester.*
- 1910, Oct. 18. Evans, Evan Jenkin, B.Sc., Assistant Lecturer and Demonstrator in Physics in the University of Manchester. *The University, Manchester.*
- 1914, Feb. 24. Evans, William David, M.A., Richardson Lecturer in Mathematics, The Victoria University of Manchester. *17, Harley Avenue, Victoria Park, Manchester.*
- 1912, Oct. 15. Fairlie, D. M., M.Sc. 232, *Burton Road, West Didsbury, Manchester.*
- 1912, Feb. 6. Forder, H. G., B.A., Senior Mathematical Master, Cardiff High School. 33, *Wordsworth Avenue, Newport Road, Cardiff.*
- 1908, Jan. 28. Fox, Thomas William, M.Sc.Tech., Professor of Textiles in the School of Technology, Manchester University. *Gledfield, 15, Clarendon Crescent, Eccles.*
- 1912, Oct. 15. Garnett, J. C. Maxwell, M.A., Principal of the Municipal School of Technology, Manchester. *The Municipal School of Technology, Sackville Street, Manchester, and Westfield, Victoria Park, Manchester.*
- 1909, Mar. 23. Gee, W. W. Haldane, B.Sc., M.Sc.Tech., A.M.I.E.E., Professor of Pure and Applied Physics in the School of Technology, Manchester University. *Oak Lea, Whalley Avenue, Sale.*
- 1907, Oct. 15. Gravely, F. H., M.Sc. *Natural History Dept., Indian Museum, Calcutta.*
- 1907, Oct. 29. Gwyther, Reginald Felix, M.A., Secretary to the Joint Matriculation Board. 21, *Booth Avenue, Withington, Manchester.*

*Date of Election.*

- 1913, Dec. 16. Handley, Marion, M.A. (Birm.), Lecturer in the Municipal Day Training College, Manchester. *Himmel, Burnage Garden Village, Manchester.*
- 1911, Oct. 3. Hassé, H. R., M.A., D.Sc., Lecturer in Mathematics in the University of Manchester. 69, *Mauideth Road, Withington, Manchester.*
- 1914, Mar. 10. Hibbert, Eva, Assoc.M.S.T., Demonstrator in Chemistry, The Municipal School of Technology, Manchester. *The Municipal School of Technology, Manchester.*
- 1907, Oct. 15. Hickling, H. George A., D.Sc., F.G.S., Lecturer in Palæontology in the Victoria University of Manchester. *Glenside, Marple Bridge, near Stockport.*
- 1895, Mar. 5. Hickson, Sydney J., M.A., D.Sc., F.R.S., Professor of Zoology in the Victoria University of Manchester. *The University, Manchester.*
- 1909, Jan. 12. Hoffert, Hermann Henry, D.Sc. (Lond.), A.R.S.M., His Majesty's Inspector of Schools. *Lime Grove, Brooklands, Sale.*
- 1909, Nov. 2. Holland, Sir Thomas H., K.C.I.E., D.Sc., F.R.S., Professor of Geology and Mineralogy in the University of Manchester, late Director of the Geological Survey of India. *Westwood, Alderley Edge, Cheshire.*
- 1905, Nov. 14. Holt, Alfred, M.A., D.Sc., Research Fellow of the University of Manchester. *Dowsefield, Allerton, Liverpool.*
- 1896, Nov. 3. Hopkinson, Edward, M.A., D.Sc., M.Inst.C.E. *Ferns, Alderley Edge, Cheshire.*
- 1909, Feb. 9. Howles, Frederick, M.Sc., Analytical and Research Chemist. *Glenluce, Waterpark Road, Broughton Park, Manchester.*
- 1889, Oct. 15. Hoyle, William Evans, M.A., D.Sc., F.R.S.E., Director of the Welsh National Museum, Cardiff. *City Hall, Cardiff.*
- 1913, Feb. 4. Hubrecht, J. B., M.A. 12, *Campton Hill Gardens, London, W.*
- 1907, Oct. 15. Hübner, Julius, M.Sc.Tech., F.I.C., Lecturer in the Faculty of Technology in the University of Manchester. *Linden, Cheadle Hulme, Cheshire.*
- 1913, Oct. 21. Imms, A. D., M.A., D.Sc., F.L.S., Reader in Agricultural Entomology in the Victoria University of Manchester. *Department of Agricultural Entomology, The University, Manchester.*

*Date of Election.*

- 1899, Oct. 17. Ingleby, Joseph, M.I.Mech.E. *Springfield, Holly Road, Wilmslow, Cheshire, and 20, Mount Street, Manchester.*
- 1901, Nov. 26. Jackson, Frederick. 44, *Chapel Street, Salferd.*
- 1914, Jan. 13. Jenkins, William Charles, Curator of the Godlee Observatory. The Municipal School of Technology, Manchester. *The Municipal School of Technology, Manchester.*
- 1911, Oct. 3. Johnstone, Mary A., B.Sc.(Lond.), Headmistress of the Municipal Secondary School for Girls, Whitworth Street, Manchester. 43, *Hill Top Avenue, Cheadle Hulme, Cheshire.*
- 1878, Nov. 26. Jones, Francis, M.Sc., F.R.S.E., F.C.S. *Manchester Grammar School, and 17, Whalley Road, Whalley Range, Manchester.*
- 1903, Feb. 3. Knecht, Edmund, Ph.D., Professor of Chemistry in the School of Technology, Manchester University. *Beech Mount, Marple, Cheshire.*
- 1893, Nov. 14. Lamb, Horace, M.A., I.L.D., D.Sc., Sc.D., F.R.S., Professor of Mathematics in the Victoria University of Manchester. 6, *Wilbraham Road, Fallowfield, Manchester.*
- 1909, Nov. 2. Lang, William H., M.B., C.M., D.Sc., F.R.S., F.L.S., Barker Professor of Cryptogamic Botany in the University of Manchester. 2, *Heaton Road, Withington, Manchester.*
- 1902, Jan. 7. Lange, Ernest F., M.I.Mech.E., A.M.Inst.C.E., M.I. & S. Inst., F.C.S. *Fairholm, 3, Willow Bank, Fallowfield, Manchester.*
- 1911, Jan. 10. Lankshcar, Fredrick Russell, B.A. (New Zeal.), M.Sc. (Mane.), Demonstrator in Chemistry in the Victoria University Manchester. *The University, Manchester.*
- 1910, Oct. 18. Lapworth, Arthur, D.Sc., F.R.S., F.I.C., Professor of Organic Chemistry in the Victoria University of Manchester. 30, *Amherst Road, Withington, Manchester.*
- 1904, Mar. 15. Lea, Arnold W. W., M.D. 246, *Oxford Road, Manchester.*
- 1914, April 7. Lees, S., M.A., Assoc.M.S.T., Reader in Applied Thermodynamics in the Faculty of Technology, The University of Manchester. *The Municipal School of Technology, Manchester, and Brierfield, Ashley Road, Hale, Cheshire.*
- 1907, Oct. 29. Leigh, Harold Shawcross. *Brentwood, Worsley.*

Ordinary Members.

lix

*Date of Election.*

- 1908, Oct. 20. Liebert, Martin, Ph.D., Managing Director of Meister Lucius and Brüning, Ltd., Manchester. 1, *Lancaster Road, Didsbury, Manchester.*
- 1912, Nov. 12. Lindsey, Marjorie, B.Sc., Research Student in the Victoria University of Manchester. 3, *Demesne Road, Whalley Range, Manchester.*
- 1912, May 7. Loewenfeld, Kurt, Ph.D. *Fern Bank, Ogden Road, Bramhall, Cheshire.*
- 1910, Oct. 18. McDougall, Robert, B.Sc. *City Flour Mills, German Street, Manchester.*
- 1912, Oct. 15. McFarlane, John, M.A. (Edin.), B.A. (Cantab), M.Com. (Manc.), Lecturer in Geography in the Victoria University of Manchester. *The University, Manchester.*
- 1905, Oct. 31. McNicol, Mary, M.Sc. 182, *Upper Chorlton Road, Manchester.*
- 1904, Nov. 1. Makower, Walter, B.A., D.Sc. (Lond.), Lecturer in Physics in the University of Manchester. *Maylands, Brook Road, Fallowfield, Manchester.*
- 1902, Mar. 4. Mandlberg, Goodman Charles. *Redciff, Victoria Park, Manchester.*
- 1911, Oct. 31. March, Margaret Colley, M.Sc. *The University, Edinburgh.*
- 1901, Dec. 10. Massey, Herbert. *Ivy Lea, Burnage, Didsbury, Manchester.*
- 1864, Nov. 1. Mather, Sir William, P.C., M.Inst.C.E., M.I.Mech.E. *Iron Works, Salford.*
- 1912, Nov. 26. Melland, Edward. *Kia Ora, Hale, Cheshire.*
- 1873, Mar. 18. Melvill, James Cosmo, M.A., D.Sc., F.L.S. *Meole Brace Hall, Shrewsbury.*
- 1894, Feb. 6. Mond, Robert Ludwig, M.A., F.R.S.E., F.C.S. *Winnington Hall, Northwich, Cheshire.*
- 1912, Nov. 26. Myers, J. E., M.Sc., Beyer Fellow and Assistant Lecturer in Chemistry in the Victoria University of Manchester. *Acresfield, Gatley, Cheshire.*
- 1908, Jan. 28. Myers, William, Lecturer in Textiles in the School of Technology, Manchester University. *Acresfield, Gatley, Cheshire.*
- 1873, Mar. 4. Nicholson, Francis, F.Z.S. *The Knoll, Windermere, Westmorland.*

*Date of Election.*

- 1884, April 15. Okell, Samuel, F.R.A.S. *Overley, Langham Road, Bowdon, Cheshire.*
- 1892, Nov. 15. Perkin, W. H., Sc.D., Ph.D., M.Sc., F.R.S., Waynflete Professor of Chemistry in the University of Oxford. *The University, Oxford.*
- 1901, Oct. 29. Petavel, J. E., B.A., D.Sc., F.R.S., Professor of Engineering in the Victoria University of Manchester. *The University, Manchester.*
- 1885, Nov. 17. Phillips, Henry Harcourt. F.C.S. *Lynwood, Turton, near Bolton, Lancs.*
- 1903, Dec. 15. Prentice, Bertram, Ph.D., D.Sc., Principal, Royal Technical Institute, Salford. *Isca Mennt, Manchester Road, Swinton.*
- 1901, Dec. 10. Ramsden, Herbert, M.D. (Lond.), M.B., Ch.B. (Vict.) *Sunnyside, Dobcross, near Oltham, Lancs.*
- 1888, Feb. 21. Rée, Alfred, Ph.D., F.C.S. 15, *Mauldeth Road, Withington, Manchester.*
- 1913, Jan. 7. Renold, Hans, M.I.Mech.E. *Friestnall Hey, Licaton Mersey, near Manchester.*
- 1910, Oct. 4. Rhead, E. L., M.Sc.Tech., F.I.C., Lecturer in Metallurgy and Assaying, The Municipal School of Technology, Manchester. *Stoneycroft, Polygon Avenue, Levenshulme, Manchester.*
- 1912, Oct. 29. Roberts, A. W. Rymer, M.A., *Ellerbeck, Crook, near Kendal.*
- 1880, Mar. 23. Roberts, D. Lloyd, M.D., F.R.S.E., F.R.C.P. (Lond.). *Ravenswood, Broughton Park, Manchester.*
- 1911, Jan. 10. Robinson, Robert, D.Sc. (Vict.), Professor in the University of Sydney. N.S.W. *The University, Sydney, N.S.W.*
- 1910, Oct. 18. Rossi, Roberto, M.Sc. *Trinity College, Cambridge.*
- 1897, Oct. 19. Rothwell, William Thomas. *Heath Brewery, Newton Heath, near Manchester.*
- 1907, Oct. 15. Rutherford, Sir Ernest, M.A., D.Sc., F.R.S., Langworthy Professor of Physics in the University of Manchester. *17, Wilmslow Road, Withington, Manchester.*



Ordinary Members.

181

*Date of Election.*

- 1909, Jan. 26. Schmitz, Hermann Emil, M.A., B.Sc., Physics Master at the Manchester Grammar School, 15, *Brighton Grove, Rusholme, Manchester.*
- 1873, Nov. 18. Schuster, Arthur. Sc.D., Ph.D., Sec.R.S., F.R.A.S., Honorary Professor of Physics in the Victoria University of Manchester. *Yeldall, Trwyford, Berks.*
- 1898, Jan. 25. Schwabe, Louis. *Hart Hill, Eccles Old Road, Pendleton, Manchester.*
- 1890, Nov. 4. Sidebotham, Edward John, M.A., M.B., M.R.C.S. *Erlesdene, Bowdon, Cheshire.*
- 1903, April 28. Sidelbottom, Henry. *Woodstock, Bramhall, Cheshire.*
- 1910, Oct. 4. Smith, Grafton Elliot, M.A., M.D., F.R.S., Professor of Anatomy in the University of Manchester. *The University, Manchester.*
- 1906, Nov. 27. Smith, Norman, D.Sc., Assistant Lecturer in Chemistry in the Victoria University of Manchester. *The University, Manchester.*
- 1896, Feb. 18. Spence, David. *Lowood, Hindhead, Haslemere, R.S.O., Surrey.*
- 1901, Dec. 10. Spence, Howard. *C/o Messrs. Peter Spence & Sons, Ltd., Alum Works, Manchester.*
- 1911, Oct. 17. Start, Laura, Lecturer in Art and Handicraft in the University of Manchester. *Moor View, Mayfield Road, Kersal, Manchester.*
- 1897, Nov. 30. Stromeyer, C. E., M.Inst.C.E., M.Inst.M.E., M.I.&S.Inst. *Steam Users' Association, 9, Mount Street, Albert Square, Manchester, and Landfield, West Didsbury.*
- 1910, Oct. 18. Tattersall, Walter Medley, D.Sc., Keeper of the Manchester Museum. *The Manchester Museum, The University, Manchester.*
- 1895, April 9. Tatton, Reginald A., M.Inst.C.E., Engineer to the Mersey and Irwell Joint Committee. *Manor House, Chelford, Cheshire.*
- 1893, Nov. 14. Taylor, R. L., F.C.S., F.I.C. *Central High School for Boys, Whitworth Street, and 37, Mayfield Road, Whalley Range, Manchester.*
- 1906, April 10. Thewlis, Councillor J. H. *Daisy Mount, Victoria Park, Manchester.*

*Date of Election.*

- 1911, Oct. 17. Thoday, D., M.A., Lecturer in Plant Physiology in the University of Manchester. *The University, Manchester.*
- 1911, Jan. 10. Thomson, J. Stuart, Ph.D. (Bern), F.L.S., F.R.S.E., Senior Demonstrator in Zoology in the Victoria University of Manchester. *The University, Manchester.*
- 1873, April 15. Thomson, William, F.R.S.E., F.I.C., F.C.S. *Royal Institution, Manchester.*
- 1896, Jan. 21. Thorburn, William, M.D., B.Sc. 2, *St. Peter's Square, Manchester.*
- 1899, Oct. 17. Todd, William Henry. *Rivington, Irlam Road, Flixton, near Manchester.*
- 1909, Jan. 26. Varley, George Percy, M.Sc. (Vic.), Assistant Master in the Central High School for Boys, Whitworth Manchester. 19, *Mayfield Road, Whalley Range, Manchester.*
- 1912, Oct. 15. Walker, Miles, M.A., M.I.E.E., Professor of Electrical Engineering, the Municipal School of Technology, Manchester. *The Cottage, Leicester Road, Hale, Altrincham.*
- 1873, Nov. 18. Waters, Arthur William, F.L.S., F.G.S. *Alderley, McKinley Road, Bournemouth.*
- 1906, Nov. 13. Watson, D. M. S., M.Sc. 60, *Lissenden Mansions, Highgate Road, London, N.W.*
- 1892, Nov. 15. Weiss, F. Ernest, D.Sc., F.L.S., Acting Vice-Chancellor and Professor of Botany in the Victoria University of Manchester. *Easdale, Disley, Cheshire.*
- 1909, Feb. 9. Weizmann, Charles, Ph.D., D.Sc., Reader in Bio-Chemistry in the Victoria University of Manchester. *The University, Manchester.*
- 1908, May 12. Welldon, Rt. Rev. J. E. C., D.D., Dean of Manchester. *The Deanery, Manchester.*
- 1911, Oct. 17. West, Tom, B.Sc., Chemist and Metallurgist. 101, *Spring Bank Street, Stalybridge, near Manchester.*
- 1901, Oct. 1. Wild, Robert B., M.D., M.Sc., F.R.C.P., Professor of Materia Medica and Therapeutics in the Victoria University of Manchester. 96, *Mosley Street, Manchester.*

*Date of Election.*

- 1859, Jan. 25. Wilde, Henry, D.Sc., D.C.L., F.R.S. *The Hurst, Alderley Edge, Cheshire.*
- 1909, Jan. 26. Wolfenden, John Henry, B.Sc. (Lond.), A.R.C.S. (Lond.), Assistant Master in the Central High School for Boys, Whitworth Street, Manchester. 13, *Pole Lane, Fails-worth.*
- 1905, Oct. 31. Woodall, Herbert J., A.R.C.S. 32, *Market Place, Stockport.*
- 1860, April 17. Woolley, George Stephen. *Victoria Bridge, Manchester.*
- 1863, Nov. 17. Worthington, Samuel Barton, M.Inst.C.E., M.I.Mech.E. *Mill Bank, Bowdon, and 37, Princess Street, Manchester.*
- 1895, Jan. 8. Worthington, Wm. Barton, B.Sc., M.Inst.C.E. *Kirkstyles, Duffield, near Derby.*

---

N.B.—Of the above list the following have compounded for their subscriptions, and are therefore life members:—

Bailey, Charles, M.Sc., F.I.S.

Bradley, Nathaniel, F.C.S.

Ingleby, Joseph, M.I.Mech.E.

Worthington, Wm. Barton, B.Sc., M.Inst.C.E.

## HONORARY MEMBERS.

*Date of Election.*

- 1892, April 26. Abney, Sir William de W., K.C.B., D.C.L., D.Sc., F.R.S.  
*Rathmore Lodge, Bolton Gardens South, South Kensington,  
London, S. W.*
- 1892, April 26. Amagat, É. H., For. Mem. R.S., Memb. Inst. Fr.  
(Acad. Sci.), Examineur à l'École Polytechnique.  
*Avenue d'Orléans, 19, Paris.*
- 1894, April 17. Appell, Paul, Membre de l'Institut, Professor of Theoretical  
Mechanics. *Faculté des Sciences, Paris.*
- 1892, April 26. Baeyer, Adolf von, For. Mem. R.S., Professor of Chemistry  
in the University of Munich. 1, *Arçisstrasse, Munich.*
- 1886, Feb. 9. Baker, John Gilbert, F.R.S., F.L.S. 3, *Cumberland  
Road, Kew.*
- 1889, April 30. Carruthers, William, F.R.S., F.L.S. 44, *Central Hill,  
Norwood, London, S. E.*
- 1903, April 28. Clarke, Frank Wigglesworth, D.Sc. *United States  
Geological Survey, Washington, D. C., U.S. A.*
- 1866, Oct. 30. Clifton, Robert Bellamy, M.A., F.R.S., F.R.A.S., Pro-  
fessor of Experimental Philosophy in the University of  
Oxford. 3, *Baratweil Road, Banbury Road, Oxford.*
- 1892, April 26. Curtius, Theodor, Professor of Chemistry in the University  
of Kiel. *Universität, Kiel.*
- 1892, April 26. Darboux, J. Gaston, Membre de l'Institut, Secrétaire per-  
pétuel de l'Académie des Sciences, Doyen honoraire de  
la Faculté des Sciences. 3, *Rue Mazarine, Paris.*
- 1894, April 17. Debus, H., Ph.D., F.R.S. 4. *Schlangerweg, Cassel  
Hessen, Germany.*

*Date of Election.*

- 1900, April 24. Dewar, Sir James, M.A., LL.D., D.Sc., F.R.S., V.P.C.S.,  
Fullerian Professor of Chemistry at the Royal Institution.  
*Royal Institution, Albemarle Street, London, W.*
- 1892, April 26. Edison, Thomas Alva. *Orange, N.J., U.S.A.*
- 1895, April 30. Elster, Julius, Ph.D. *6, Lessingstrasse, Wolfenbüttel.*
- 1900, April 24. Ewing, Sir J. Alfred, K.C.B., M.A., LL.D., F.R.S.,  
Director of Naval Education to the Admiralty. *Frog-  
hole, Edenbridge, Kent.*
- 1889, April 30. Farlow, W. G., Professor of Botany at Harvard College.  
*Harvard College, Cambridge, Mass., U.S.A.*
- 1900, April 24. Forsyth, Andrew Russell, M.A., Sc.D., LL.D., F.R.S.  
Professor of Mathematics at the Imperial College of  
Science and Technology. *The Imperial College of  
Science and Technology, S. Kensington, London.*
- 1892, April 26. Fühbringer, Max, Professor of Anatomy in the University  
of Heidelberg. *Universität, Heidelberg.*
- 1900, April 24. Geikie, James, D.C.L., LL.D., F.R.S., Murchison Pro-  
fessor of Geology and Mineralogy in the University of  
Edinburgh. *Kilmorie, Colinton Road, Edinburgh.*
- 1895, April 30. Geitel, Hans. *6, Lessingstrasse, Wolfenbüttel.*
- 1894, April 17. Glaisher, J. W. L., Sc.D., F.R.S. *Trinity College,  
Cambridge.*
- 1894, April 17. Gouy, A., Corr. Memb. Inst. Fr. (Acad. Sci.), Professor  
of Physics in the University of Lyons. *Faculté des  
Sciences, Lyons.*
- 1900, April 24. Haeckel, Ernst, Ph.D., Professor of Zoology in the Uni-  
versity of Jena. *Zoologisches Institut, Jena.*
- 1894, April 17. Harcourt, A. G. Vernon, M.A., D.C.L., F.R.S., V.P.C.S.  
*St. Clare, Ryde, Isle of Wight.*
- 1894, April 17. Heaviside, Oliver, Ph.D., F.R.S. *Homefield, Lower War-  
berry, Torquay.*
- 1892, April 26. Hill, G. W. *West Nyack, N. Y., U.S.A.*

*Date of Election.*

- 1888, April 17. Hittorf, Johann Wilhelm, Professor of Physics at Münster, *Polytechnicum, Münster.*
- 1892, April 26. Klein, Felix, Ph.D., For. Mem. R.S., Corr. Memb. Inst. Fr. (Acad. Sci.), Professor of Mathematics in the University of Göttingen. 3, *Wilhelm Weber Strasse, Göttingen.*
- 1894, April 17. Königsberger, Leo, Professor of Mathematics in the University of Heidelberg. *Universität, Heidelberg.*
- 1902, May 13. Larmor, Sir Joseph, M.A., D.Sc., LL.D., F.R.S., F.R.A.S. *St. John's College, Cambridge.*
- 1892, April 26. Liebermann, C., Professor of Chemistry in the University of Berlin. 29, *Matthäi-Kirch Strasse, Berlin.*
- 1887, April 19. Lockyer, Sir J. Norman, K.C.B., LL.D., Sc.D., F.R.S., Corr. Memb. Inst. Fr. (Acad. Sci.). *Hill Observatory, Salcombe Regis, Sidmouth, Devon.*
- 1902, May 13. Lodge, Sir Oliver Joseph, D.Sc., LL.D., F.R.S., Principal of the University of Birmingham. *The University, Birmingham.*
- 1900, April 24. Lorentz, Henrik Anton, For. Mem. R.S., Corr. Memb. Inst. Fr. (Acad. Sci.), Professor of Physics in the University of Haarlem. *Zijweg, 76, Haarlem.*
- 1892, April 26. Marshall, Alfred, M.A., formerly Professor of Political Economy in the University of Cambridge. *Balliol Croft, Madingley Road, Cambridge.*
- 1901, April 23. Metschnikoff, Élie, D.Sc., For. Mem. R.S. *Institut Pasteur, Paris.*
- 1895, April 30. Mittag-Leffler, Gösta, D.C.L. (Oxon.), For. Mem. R.S., Professor of Mathematics in the University of Stockholm, *Djursholm, Stockholm.*
- 1910, April 5. Nernst, Geh. Prof. Dr. Walter, Director of the Physikal-Chemisches Institut in the University of Berlin. *Am Karlsbad 26a, Berlin W. 35.*

*Date of Election.*

- 1902, May 13. Osborn, Henry Fairfield, Professor of Vertebrate Palaeontology at Columbia College. *American Museum of Natural History, W. 77 Street, New York, U.S.A.*
- 1894, April 17. Ostwald, W., Professor of Chemistry. *Groschothen, Kgr. Sachsen.*
- 1899, April 25. Palgrave, Sir Robert H. Inglis, F.R.S., F.S.S. *Henstead Hall, Wrentham, Suffolk.*
- 1894, April 17. Pfeffer, Wilhelm, For. Mem. R.S., Professor of Botany in the University of Leipsic. *Botanisches Institut, Leipsic.*
- 1892, April 26. Quincke, G. H., For. Mem. R.S., Professor of Physics in the University of Heidelberg. *Universität, Heidelberg.*
- 1899, April 25. Ramsay, Sir William, K.C.B., Ph.D., Sc.D., M.D., F.R.S., Professor of Chemistry in University College, London. *19, Chester Terrace, Regent's Park, London, N. W.*
- 1886, Feb. 9. Rayleigh, Right Hon. John William Strutt, Lord, O.M., M.A., D.C.L. (Oxon.), Sc.D. (Cantab.), LL.D. (Univ. McGill), F.R.S., F.R.A.S., Corr. Memb. Inst. Fr. (Acad. Sci.), Chancellor of the University of Cambridge. *Terling Place, Witham, Essex.*
- 1900, April 24. Ridgway, Robert, Curator of the Department of Birds, U.S. National Museum. *Brookland, District of Columbia, U.S.A.*
- 1897, April 27. Roseoe, Right Hon. Sir Henry Enfield, B.A., D.C.L. LL.D., F.R.S., V.P.C.S., Corr. Memb. Inst. Fr. (Acad. Sci.). *West-Horsley, Leatherhead, Surrey.*
- 1902, May 13. Scott, Dukinfield Henry, M.A., LL.D., Ph.D., F.R.S., F.L.S. *East Oakley House, Oakley, Hants.*
- 1892, April 26. Solms, H., Graf zu, Professor of Botany in the University of Strassburg. *Universität, Strassburg.*
- 1892, April 26. Thibetson-Dyer, Sir William T., K.C.M.G., C.I.E., M.A., Sc.D., Ph.D., LL.D., F.R.S. Lately Director Royal Botanic Gardens, Kew. *The Ferns, Wilcombe, Gloucester.*

*Date of Election.*

- 1895, April 30. Thomson, Sir Joseph John, O.M., M.A., Sc.D., F.R.S.,  
Cavendish Professor of Experimental Physics in the  
University of Cambridge. *Trinity College, Cambridge.*
- 1894, April 17. Thorpe, Sir T. Edward, C.B., Ph.D., D.Sc., LL.D.,  
F.R.S., V.P.C.S. *Whinfield, Salcombe, S. Devon.*
- 1894, April 17. Turner, Sir William, K.C.B., M.B., D.C.L., LL.D.,  
Sc.D., F.R.S., F.R.S.E., Professor of Anatomy in the  
University of Edinburgh. *6, Eton Terrace, Edinburgh.*
- 1886, Feb. 9. Tylor, Sir Edward Burnett, D.C.L. (Oxon), LL.D. (St.  
And. and McGill Univs.), F.R.S., formerly Professor of  
Anthropology in the University of Oxford. *Linden,  
Wellington, Somerset.*
- 1894, April 17. Vines, Sidney Howard, M.A., D.Sc., F.R.S., F.L.S.,  
Sherardian Professor of Botany in the University of  
Oxford. *Heatington Hill, Oxford.*
- 1894, April 17. Warburg, Emil, Professor of Physics at the Physical  
Institute, Berlin. *Physikalisches Institut, Neue Wilhelm-  
strasse, Berlin.*
- 1894, April 17. Weismann, August, For. Mem. R.S., Professor of Zoology  
in the University of Freiburg. *Universität, Freiburg i.  
Br.*

**CHANGES OF ADDRESS.**

*Members are particularly requested to inform the Secretaries  
of any errors in their addresses or descriptions.*

*Awards of the Dalton Medal.*

1898. EDWARD SCHUNCK, Ph.D., F.R.S.  
1900. Sir HENRY E. ROSCOE, F.R.S.  
1903. Prof. OSBORNE REYNOLDS, LL.D., F.R.S.



*THE WILDE LECTURES.*

---

1897. (July 2) "On the Nature of the Röntgen Rays." By Sir G. G. STOKES, Bart., F.R.S. (28 pp.)
1898. (Mar. 29.) "On the Physical Basis of Psychical Events." By Sir MICHAEL FOSTER, K.C.B., F.R.S. (46 pp.)
1899. (Mar. 28) "The newly discovered Elements; and their relation to the Kinetic Theory of Gases." By Prof. WILLIAM RAMSAY, F.R.S. (19 pp.)
1900. (Feb. 13.) "The Mechanical Principles of Flight." By the Rt. Hon. LORD RAYLEIGH, F.R.S. (26 pp.)
1901. (April 22.) "Sur la Flore du Corps Humain." By Dr. ÉLIE METSCHNIKOFF, For.Mem.R.S. (38 pp.)
1902. (Feb. 25.) "On the Evolution of the Mental Faculties in relation to some Fundamental Principles of Motion." By Dr. HENRY WILDE, F.R.S. (34 pp., 3 pls.)
1903. (May 19.) "The Atomic Theory." By Professor F. W. CLARKE, D.Sc. (32 pp.)
1904. (Feb. 23.) "The Evolution of Matter as revealed by the Radio-active Elements." By FREDERICK SODDY, M.A. (42 pp.)

1905. (Feb. 28.) "The Early History of Seed-bearing Plants, as recorded in the Carboniferous Flora." By Dr. D. H. SCOTT, F.R.S. (32 pp., 3 pls.)
1906. (March 20.) "Total Solar Eclipses." By Professor H. H. TURNER, D.Sc., F.R.S. (32 pp.)
1907. (February 18.) "The Structure of Metals." By Dr. J. A. EWING, F.R.S., M.Inst.C.E. (20 pp., 5 pls., and 5 text-figs.)
1908. (March 3.) "On the Physical Aspect of the Atomic Theory." By Professor J. LARMOR, Sec. R.S. (54 pp.)
1909. (March 9.) "On the Influence of Moisture on Chemical Change in Gases." By Dr. H. BRERETON BAKER, F.R.S. (8 pp.)
1910. (March 22.) "Recent Contributions to Theories regarding the Internal Structure of the Earth." By Sir THOMAS H. HOLLAND, K.C.I.E., D.Sc., F.R.S.

---

*SPECIAL LECTURES.*

1913. (March 4.) "The Plant and the Soil." By A. D. HALL, M.A., F.R.S.
1914. (March 18.) "Crystalline Structure as revealed by X-rays." By Professor W. H. BRAGG, M.A., F.R.S.

*LIST OF PRESIDENTS OF THE SOCIETY.**Date of Election.*

- 
1781. PETER MAINWARING, M.D., JAMES MASSEY.  
1782-1786. JAMES MASSEY, THOMAS PERCIVAL, M.D., F.R.S.  
1787-1789. JAMES MASSEY.  
1789-1804. THOMAS PERCIVAL, M.D., F.R.S.  
1805-1806. REV. GEORGE WALKER, F.R.S.  
1807-1809. THOMAS HENRY, F.R.S.  
1809. \*JOHN HULL, M.D., F.L.S.  
1809-1816. THOMAS HENRY, F.R.S.  
1816-1844. JOHN DALTON, D.C.L., F.R.S.  
1844-1847. EDWARD HOLME, M.D., F.L.S.  
1848-1850. EATON HODGKINSON, F.R.S., F.G.S.  
1851-1854. JOHN MOORE, F.L.S.  
1855-1859. SIR WILLIAM FAIRBAIRN, Bart., LL.D., F.R.S.  
1860-1861. JAMES PRESCOTT JOULE, D.C.L., F.R.S.  
1862-1863. EDWARD WILLIAM BINNEY, F.R.S., F.G.S.  
1864-1865. ROBERT ANGUS SMITH, Ph.D., F.R.S.  
1866-1867. EDWARD SCHUNCK, Ph.D., F.R.S.  
1868-1869. JAMES PRESCOTT JOULE, D.C.L., F.R.S.  
1870-1871. EDWARD WILLIAM BINNEY, F.R.S., F.G.S.  
1872-1873. JAMES PRESCOTT JOULE, D.C.L., F.R.S.  
1874-1875. EDWARD SCHUNCK, Ph.D., F.R.S.  
1876-1877. EDWARD WILLIAM BINNEY, F.R.S., F.G.S.  
1878-1879. JAMES PRESCOTT JOULE, D.C.L., F.R.S.  
1880-1881. EDWARD WILLIAM BINNEY, F.R.S., F.G.S.  
1882-1883. SIR HENRY ENFIELD ROSCOE, D.C.L., F.R.S.  
1884-1885. WILLIAM CRAWFORD WILLIAMSON, LL.D., F.R.S.  
1886. ROBERT DUKINFIELD DARBISHIRE, B.A., F.G.S.  
1887. BALFOUR STEWART, LL.D., F.R.S.

\* Elected April 28th; resigned office May 5th.

lxxii      *List of Presidents of the Society.*

*Date of Election.*

- 1888-1889.    OSBORNE REYNOLDS, LL.D., F.R.S.  
1890-1891.    EDWARD SCHUNCK, Ph.D., F.R.S.  
1892-1893.    ARTHUR SCHUSTER, Ph.D., F.R.S.  
1894-1896.    HENRY WILDE, D.C.L., F.R.S.  
                  1896.        EDWARD SCHUNCK, Ph.D., F.R.S.  
1897-1899.    JAMES COSMO MELVILL, M.A., F.L.S.  
1899-1901.    HORACE LAMB, M.A., F.R.S.  
1901-1903.    CHARLES BAILEY, M.Sc., F.L.S.  
1903-1905.    W. BOYD DAWKINS, M.A., D.Sc., F.R.S.  
1905-1907.    Sir WILLIAM H. BAILEY, M.I.Mech.E.  
1907-1909.    HAROLD BAILY DIXON, M.A., F.R.S.  
1909-1911.    FRANCIS JONES, M.Sc., F.R.S.E.  
1911-1913.    F. E. WEISS, D.Sc., F.L.S.  
1913-         FRANCIS NICHOLSON, F.Z.S.
-

MEMOIRS AND PROCEEDINGS  
OF  
THE MANCHESTER  
LITERARY & PHILOSOPHICAL  
SOCIETY, 1913-1914.

## CONTENTS.

## Inaugural Address :

The Old Manchester Natural History Society and its Museum.

By the President, Francis Nicholson, F.Z.S. . . . pp. 1-15.

(*Issued separately, December 2nd, 1913.*)

## Memoirs :

I. Changes in the branchial lamellae of *Ligia oceanica*, after prolonged immersion in fresh and salt water. By Dorothy

A. Stewart, B.Sc. *With 2 Pls.* . . . . . pp. 1-12.

(*Issued separately, December 31st, 1913.*)

II. Note on some products isolated from Soot. By Professor

Edmund Knecht, Ph.D., and Eva Hibbert, Assoc.M.S.T.- pp. 1-5.

(*Issued separately, December 17th, 1913.*)

III. The Willow Titmouse in Lancashire and Cheshire. By T. A.

Coward, F.Z.S., F.E.S. . . . . pp. 1-8.

(*Issued separately, March 27th, 1914.*)

Proceedings . . . . . pp. i.-20.

---

MANCHESTER :

36, GEORGE STREET.

—  
Price Two Shillings and Sixpence.

March 31st, 1914.

## RECENT ADDITIONS TO THE LIBRARY.

*Presented.*

- Amsterdam.**—**Kön. Akademie der Wissenschaften.** Beschreibung der Griechischen Autonomen Münzen... K. Akademie der Wissenschaften zu Amsterdam. Amsterdam, 1912. (*Recd. 20/vii./13.*)
- .——**Amaryllis.** Carmen Raphaëlis Carrozzari... Amstelodami, 1913. (*Recd. 20/xii./13.*)
- Ashworth (J. R.).** The Anhyseretic Magnetic Properties of Iron and Nickel. Part I. The Relation of Magnetic Intensity to Field Strength and Temperature. By J. R. Ashworth. [London, 1914.] (*Recd. 10/iii./14.*)
- Bamberg**—**Remeis Sternwarte.** Katalog und Ephemeriden veränderlicher Sterne für 1914. Von Ernst Hartwig. Leipzig, 1913. (*Recd. 9/i./14.*)
- Cardiff.**—**National Museum of Wales.** Catalogue of Loan Exhibition of Paintings... February and March, 1913. Cardiff, 1913. (*Recd. 3/i./14.*)
- .—— Handbook to the Exhibition of Welsh Antiquities, June-October, 1913. Cardiff, 1913. (*Recd. 3/i./14.*)
- London.**—**British Association.** A Binary Canon, showing Residues of Powers of 2 for Divisors under 1000, and Indices to Residues. By Lt.-Col. Allan Cunningham. London, 1900. (*Recd. 24/ii./14.*)
- .—— **Institution of Electrical Engineers.** Catalogue of the Lending Library. London, 1914. (*Recd. 20/ii./14.*)
- .—— **Mathematical Association.** Catalogue of Current Mathematical Journals, etc.... By W. J. Greenstreet. London, 1913. (*Recd. 17/i./14.*)
- .—— **Meteorological Office.** The International Kite and Balloon Ascents. By Ernest Gold. (Geophysical Memoirs, No. 5.) London, 1913. (*Recd. 25/ii./14.*)
- .—— The Free Atmosphere in the Region of the British Isles. Report. By W. H. Dines. (Geophysical Memoirs, No. 6.) London, 1914. (*Recd. 25/ii./14.*)
- .—— A Comparison of the Electrical Conditions of the Atmosphere at Kew and Eskdalemuir... By Gordon Dobson. (Geophysical Memoirs, No. 7.) London, 1914. (*Recd. 25/ii./14.*)

RECENT ADDITIONS TO THE LIBRARY.—*Continued.*

Southworth (H. W.). *Divine Love Vindicated.* By H. W. Southworth.  
London, n.d. (*Recd.* 22/xii./13.)

Stockholm.—Académie Royale Suédoise des Sciences. Les Prix  
Nobel en 1912. Stockholm, 1913. (*Recd.* 9/i./14.)

Washington.—Bureau of American Ethnology. Chippewa Music—II.  
By Frances Densmore. (Bulletin 53.) Washington, 1913. (*Recd.*  
31/xii./13.)

—.—United States Coast and Geodetic Survey. Results of  
Observations made at the United States Coast and Geodetic  
Survey Magnetic Observatory, near Honolulu, ... 1911 and 1912.  
By D. L. Hazard. Washington, 1913. (*Recd.* 28/xi./14.)

*Purchased.*

Philadelphia.—Academy of Natural Sciences. An Index to the Scien-  
tific Contents of the Journal and Proceedings of the Academy of  
Natural Sciences of Philadelphia, 1812-1912. Philadelphia, 1913.  
(*Recd.* 17/xi./13.)

*New Exchanges.*

Iowa City.—State University of Iowa. Contributions from the Phy-  
sical Laboratory, and Bulletin from the Laboratories of Natural  
History.

St. Louis, Mo.—Washington University. Studies.

*Exchange discontinued.*

Hanover.—Architekten-und Ingenieur-Verein. Zeitschrift für Archi-  
tektur und Ingenieurwesen.





MEMOIRS AND PROCEEDINGS  
 OF  
 THE MANCHESTER  
 LITERARY & PHILOSOPHICAL  
 SOCIETY, 1913-1914.

CONTENTS

Memoirs :

- IV. Observations on the Homopterous Insect *Phromnia (Flata) marginella* Oliv. in the Himalayas. By A. D. Imms, M.A., D.Sc. *With 2 Pls. and 1 Text-fig.* - - - - pp. 1-12.  
*(Issued separately, April 15th, 1914.)*
- V. The Specification of the Elements of Stress. Part III. The definition of the dynamical specification and a test of the elastic specification. A chapter in Elasticity. By R. F. Gwyther, M.A. - - - - - pp. 1-21.  
*(Issued separately, May 16th, 1914.)*
- VI. How does the Plant obtain its nutriment from the Soil? By A. D. Hall, M.A., F.R.S. *With 6 Pls. and 1 Text-fig.* - - pp. 1-22.  
*(Special Lecture.)*  
*(Issued separately, May 25th, 1914.)*
- VII. Some Notes on the Measurement of Air Velocities, Pressures, and Volumes. By William Cramp, M.I.E.E., M.Sc. Tech. *With 5 Text-figs.* - - - - - pp. 1-16.  
*(Issued separately, May 26th, 1914.)*
- VIII. Faunal Survey of Rostherne Mere. I. Introduction and Methods. By W. M. Tattersall, D.Sc., and T. A. Coward, F.Z.S., F.E.S. *With 1 Pl. and 1 Map.* - - - - pp. 1-21.  
*(Issued separately, May 30th, 1914.)*
- IX. Faunal Survey of Rostherne Mere. II. Vertebrata. By T. A. Coward, F.Z.S. F.E.S. - - - - - pp. 1-37.  
*(Issued separately, May 30th, 1914.)*
- X. Carbon: its molecular structure and mode of oxidation. By Maurice Copisarow, B.Sc. *With 6 Text-figs.* - - - pp. 1-11.  
*(Issued separately, May 22nd, 1914.)*

## RECENT ADDITIONS TO THE LIBRARY.

### *Presented.*

- London.—Royal Observatory, Greenwich.** Photographic Magnitudes of Stars brighter than  $9^m.0$  between Declination  $+75^\circ$  and the Pole, London, 1913. (*Recd. 30/iv./14.*)
- .— Position of the Sun's Axis, as determined from Photographs of the Sun...1874 to 1912. London, 1913. (*Recd. 30/iv./14.*)
- Oxford.—University Observatory.** Corrections to the places of the Cambridge (Ast. Gesell.) Catalogue deduced from Photographic Measures on the Plates of the Oxford Section of the Astrographic Catalogue. Oxford Astrographic Catalogue, Vol. VIII., Part I. Edinburgh, [1913.] (*Recd. 27/v./14.*)
- .— Tables for facilitating the use of Harmonic Analysis, as arranged by H. H. Turner. London, 1913. (*Recd. 27/v./14.*)
- .— Collated List of Lunar Formations named or lettered in the Maps of Neison, Schmidt, and Mädler, compiled and annotated for the Committee by Mary A. Blagg under the direction of the late S. A. Saunder. (Lunar Nomenclature Committee...). Edinburgh, 1913. (*Recd. 27/v./14.*)
- Seattle.—University of Washington.—Elements of the History of the English Language.** By Uno Lindelof (University of Washington Publications, English, I.). Seattle, 1911. (*Recd. 12/iii./14.*)
- .— The Political and Ecclesiastical Allegory of the First Book of the Faerie Queen. By F. M. Padelford (University of Washington Publications, English, II.). Boston, n.d. (*Recd. 12/iii./14.*)
- Sidebottom (Henry).** Report on the Lagenae of the South-West Pacific Ocean (Supplementary Paper). By Henry Sidebottom. London, 1913. (*Recd. 26/v./14.*)
- Washington.—Smithsonian Institution. Bureau of American Ethnology.** Ethnozoology of the Tewa Indians. By J. Henderson and J. P. Harrington. (Bulletin No. 56.) Washington, 1914. (*Recd. 15/iv./14.*)
- .— **United States Geological Survey.** Geologic Atlas of the United States. Folios 185, 187-190. Washington, D.C., 1913. (*Recd. 17/iv./14.*)
- Wisconsin.—Wisconsin History Commission.** An Artilleryman's Diary. By J. Lloyd Jones. (Original Papers, No. 8.) n.p., 1914. (*Recd. 4/v./14.*)

MEMOIRS AND PROCEEDINGS  
OF  
THE MANCHESTER  
LITERARY & PHILOSOPHICAL  
SOCIETY, 1913-1914.

CONTENTS.

Memoirs :

- XI. Note on the Intrinsic Field of a Magnet. By J. R. Ashworth, D.Sc. - - - - - pp. 1-6.  
*(Issued separately, July 20<sup>th</sup>, 1914.)*
- XII. The Specification of Stress. Part IV. The Elastic Solution: The Elastic Stress relations and conditions of Stability: Struts, ties and test-pieces. By R. F. Gwyther, M.A. - pp. 1-9.  
*(Issued separately, September 10<sup>th</sup>, 1914.)*
- XIII. Faunal Survey of Rostherne. III. Preliminary List of Lepidoptera found round the Mere. By A. W. Boyd, M.A., F.E.S. - - - - - pp. 1-12.  
*(Issued separately, June 10<sup>th</sup>, 1914.)*
- XIV. Juvenile Flowering in *Eucalyptus globulus*. By Professor F. E. Weiss, D.Sc., F.L.S. *With 2 Pls.* - - - - - pp. 1-4.  
*(Issued separately, October 31<sup>st</sup>, 1914.)*
- XV. Quantitative Absorption Spectra. Part I. The chemical significance of absorption spectra and the methods of examining them. By F. R. Lankshear, B.A., M.Sc. *With 2 Text-figs.* pp. 1-12.  
*(Issued separately, October 16<sup>th</sup>, 1914.)*

Proceedings - - - - - pp. xxi.-xxviii.

Annual Report of the Council, with Obituary Notices of Professor Paul F. Ascherson; The Right Hon. Lord Avebury, D.C.L., F.R.S.; Sir William H. Bailey, M.I.Mech.E., F.R.G.S.; Walter L. Behrens; Henry Brogden, F.G.S., M.I.Mech.E.; Robert Cotton, M.Sc.; William H. Johnson, B.Sc.; Sir John Murray, K.C.B., Sc.D., F.R.S.; Professor John T. Nicolson, D.Sc.; William H. Sutcliffe, F.G.S.; and Thomas Thorp, F.R.A.S. - - - - - xxix.-xlix

Treasurer's Accounts - - - - - pp. i.-lii.  
List of the Council and Members of the Society - - - - - pp. liii.-lxviii.  
List of the Awards of the Dalton Medal - - - - - pp. lxviii.  
List of the Wilde Lectures - - - - - pp. lxix-lxx.  
List of the Special Lectures - - - - - pp. lxx.  
List of the Presidents of the Society - - - - - pp. lxxi-lxxii.  
Title Page and Index - - - - - pp. i.-xii.

MANCHESTER:

36, GEORGE STREET.

## RECENT ADDITIONS TO THE LIBRARY.

### *Presented.*

- Cahill (B. J. S.)** An Account of a Land Map of the World. n.p., 1913.  
(*Cahill World Map Co.*) (*Recd. 3/vi.*[14.]
- Delft.—Technische Hoogeschool.** De Voeding der Oester. By J. A. Heymann. 's Gravenhage, 1914. (*Recd. 11/vii.*[14.]
- — — Biochemische Suikerbepalingen. By A. J. Kluyver. Leiden, 1914. (*Recd. 11/vii.*[14.]
- — — Over het Verwerken van Tinertsen. By Jan Rueb. Den Haag, 1913. (*Recd. 11/vii.*[14.]
- — — Drinkwaterreiniging met Hypochlorieten. By J. D. Ruys. Rotterdam, 1914. (*Recd. 11/vii.*[14.]
- — — Grundlagen der Vektor-und Affinoranalysis. By J. A. Schouten. Leipzig, &c., 1914. (*Recd. 11/vii.*[14.]
- — — De Oxydatie en de Polymerisatie van Sojaolie. By N. J. A. Tavernier. Leiden, 1913. (*Recd. 11/vii.*[14.]
- — — Temperatuurmetingen in een Dieselmotor. By E. B. Wolff. Amsterdam, n.d. (*Recd. 11/vii.*[14.]
- London.—Patent Office.** Subject List of Works on Photo-Mechanical Printing and Photography...Library of the Patent Office. (New Series, CA—CC.) London, 1914. (*Recd. 25/viii.*[14.]
- — — Subject List of Works on the Fine and Graphic Arts...Library of the Patent Office. (New Series, BM—BZ.) London, 1914. (*Recd. 25/viii.*[14.]
- — — Subject List of Works on the Silicate Industries...Library of the Patent Office. (New Series, CD—CK.) London, 1914. (*Recd. 25/viii.*[14.]
- — — Subject List of Works on General Physics...Library of the Patent Office. (New Series, FS—GF.) London, 1914. (*Recd. 18/iv.*[14.]
- — — Subject List of Works on Enamelling, Art Metalwork, Furniture, Costume and Hair Dressing and Working in the Library of the Patent Office. (New Series, CK 15—CO 17.) London, 1914. (*Recd. 18/iv.*[14.]
- — — Subject List of Works on Sound and Light (including Music...) in the Library of the Patent Office. (New Series, GG—GP.) London, 1914. (*Recd. 18/iv.*[14.]

RECENT ADDITIONS TO THE LIBRARY.—*Continued.*

**London**—**Physical Society.** Report on Radiation and the Quantum Theory. By J. H. Jeans. London, 1914. (*Recd.* 5/viii./14.)

**Madison.**—**State Historical Society of Wisconsin.** Reuben Gold Thwaites. By F. J. Turner. Madison, Wis., 1914. (*Recd.* 28/viii./14.)

**Philadelphia.**—**American Philosophical Society.** An Historical Account of the Origin . . . of the American Philosophical Society. By P. S. du Ponceau. Philadelphia, 1914. (*Recd.* 14/viii./14.)

**Washington.**—**United States Coast and Geodetic Survey.** Results of Magnetic Observations . . . U.S. Coast and Geodetic Survey. By R. L. Faris. (Special Bulletin, No. 15.) Washington, 1913. (*Recd.* 12/vi./14.)

—.—— Fourth General Adjustment . . . level Net . . . United States. By W. Bowie and H. G. Avers. (Special Bulletin, No. 18.) Washington, 1914. (*Recd.* 12/vi./14.)

—.—— Results of Observations . . . U.S. Coast and Geodetic Survey at the Observatory at Sitka, Alaska. By D. L. Hazard. Washington, 1914. (*Recd.* 12/vi./14.)

*And the usual Exchanges and Periodicals, with the exception of those received from Belgium, Russia, Germany, and Austria-Hungary.*













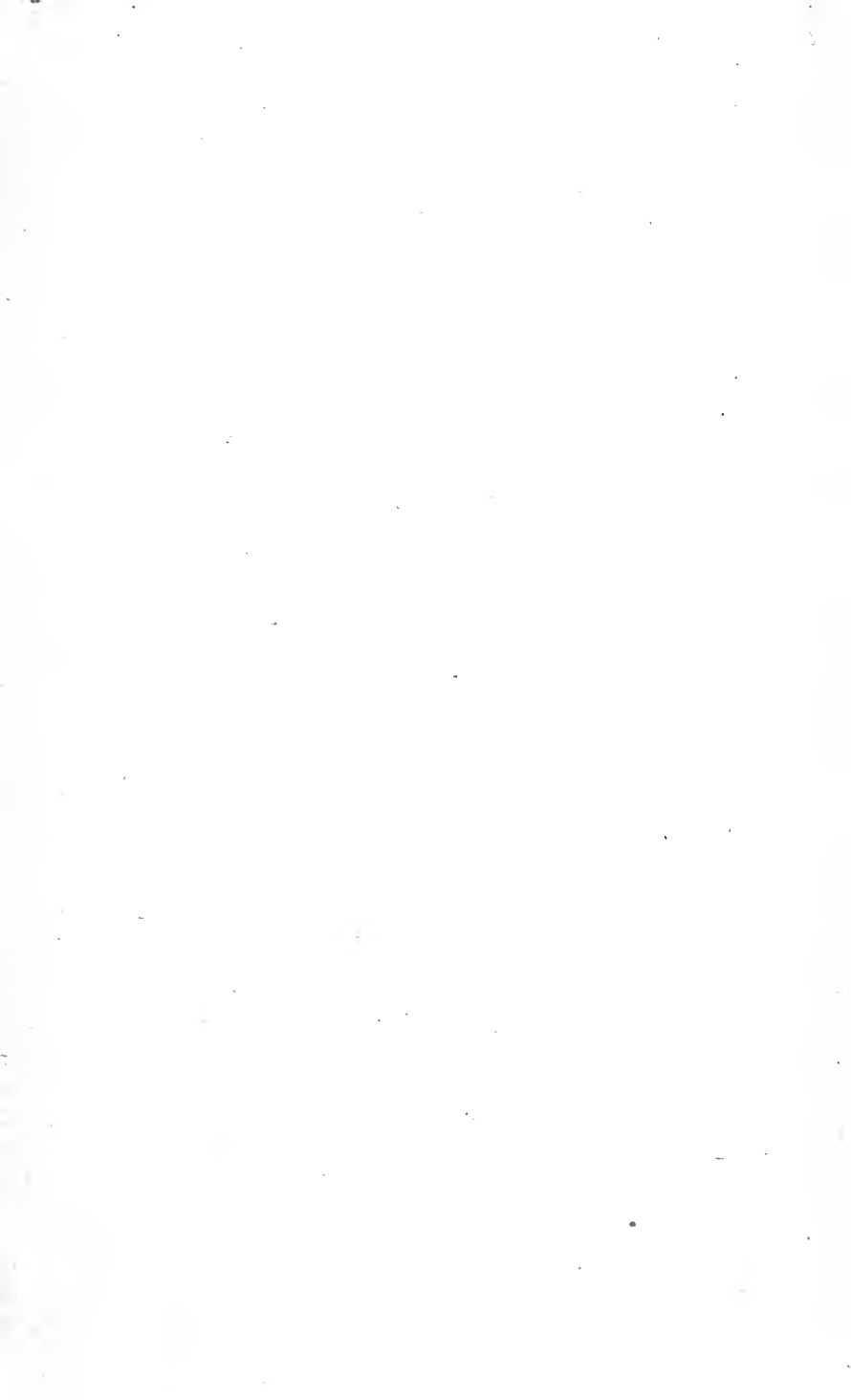

AMNH LIBRARY



100125088