

EX LIBRIS

The Metallurgy of the Common Metals,

Gold, Silver, Iron, Copper, Lead,
and Zinc

by

LEONARD S. AUSTIN

Professor of Metallurgy and Ore Dressing,
Michigan College of Mines.

Second Edition
Revised and Enlarged

1909

Published by the
Mining and Scientific Press, San Francisco,
and
The Mining Magazine, London.

176

A8

1909

COPYRIGHT, 1909

BY

DEWEY PUBLISHING COMPANY.

[Faint handwritten signature]

ADDENDA

Page.

- 22 line 6, for CO read CO_2 .
- 29 “ 9, for $\frac{62.5}{12 \times 0.7}$ read $\frac{62.5 \times 0.7}{12}$
- 29 “ 37, for 9.77 read 9.86.
- 29 “ 39, for 87% read 77%.
- 30 “ 1, for 8.5 lb. read 7.6 lb.
- 30 “ 2, for 0.87 read 0.85.
- 30 “ 4, for ‘the table’ read ‘Fig. 4’; for ‘the heat values’ read ‘for 2000° the specific heat’.
- 30 “ 6, for 8.5 read 7.6; for 0.251 read 0.281.
- 54 Omit the sentence, lines 38 and 39.
- 81 line 19, for ‘in the manner seen’ read ‘in the reaction (6)’.
- 81 “ 21 and 22, omit reaction (8) and in its place put reaction (9).
- 81 “ 25, omit ‘sulphate is formed thus’.
- 81 “ 28, omit ‘even more’; also, ‘than the former’.
- 153 last line, omit ‘in the same general way’.
- 155 line 1, for chlorine read chlorate.
- 155 “ 20, for $\text{Fe}(\text{OH})_4$ read $\text{Fe}(\text{OH})_2$.
- 195 Diagram, for 5% washes read 0.05% washes; for washes of 25% and 15% read washes of 0.25% and 0.15%; for Strong Solution 25% KCN read Strong Solution 0.25% KCN; for Medium Solution 15% KCN read Medium Solution 0.15% KCN; for Weak Solution 5% KCN read Weak Solution 0.05% KCN.
- 198 line 14, for 86a read 87a.
- 223 “ 37, for copper sulphide read copper sulphate.
- 224 “ 29, for HgS read Hg_2S .
- 244 “ 6, for $= 3\text{Hg}$ read $= 3\text{CuHg}$.
- 260 “ 26, for $\text{Na}_2\text{S}_2\text{O}_3\text{Cu}_2\text{O}_3$ read $2\text{Na}_2\text{S}_2\text{O}_3, 3\text{Cu}_2\text{S}_2\text{O}_3$.
- 270 “ 5, for 30 to 40 read 3000 to 4000.
- 270 “ 18, for 335 read 135.
- 289 “ 8, for Fe read 4Fe.
- 289 “ 14, for -1400 Cal. read +1400 Cal.
- 289 last line, for +1400 Cal. read +1600 Cal.
- 291 line 37, for 1100 read 1112.
- 297 “ 10, for native read 34.4%.
- 306 “ 8, for Fig. 130 read Fig. 132.
- 320 Insert line 23 between lines 5 and 6.
- 323 line 30, for 112 lb. read 1112 lb.
- 331 “ 22, for sulphide read sulphate.
- 332 “ 17, for 6CuSO_2 read $6\text{Cu} + \text{SO}_2$.

(OVER)

Page.

339 line 33, for Cu_2S read Cu_2O .

353 “ next to last for ‘ferrous’ read ‘sodium’, and omit ‘adding’.

353 last line, for ‘to’ read ‘in’.

354 line 1, before ‘common salt’ insert ‘200 parts of’.

354 “ 3, after ‘ CuO ’ insert ‘and Cu_2O ’, omit ‘and dissolves’.

354 Omit lines 5, 6, and 7.

354 line 10, for 2Cu read Cu . ~~2~~

354 “ 15 Reaction (4) should read $2\text{CuCl}_2 + \text{Cu}_2\text{Cl}_2 + 3\text{Fe} = 4\text{Cu} + 3\text{FeCl}_2$.

354 “ 20, for one read three; for (56) read (168); for two read four; for (126) read (252).

354 “ 24, for $3\text{Fe}_2\text{Cl}_6$ read $2\text{Fe}_2\text{Cl}_6$.

366 “ 24, for sulphide read sulphate.

366 “ 26, for SO_2 read 2SO_2 .

376 “ 12, for 157 read 159.

380 “ 21, for $\text{Pb} + \text{FeO}$ read $\text{PbS} + \text{FeO}$.

382 “ 36, for C read CO.

368 “ 6 and 7, for ‘the amount of lime — for Baryta’ read ‘the percentage of magnesia is multiplied by 1.4, and of baryta by 0.4’.

387 Charge sheet, last line, for $\frac{\text{FeO}}{\text{S}}$ read $\frac{\text{Fe}}{\text{S}}$

387 line 9, for ‘retains 1%’ read ‘retains 0.85%’.

387 “ 10, for $\frac{203}{0.35}$ or 600 lb. read $\frac{203}{0.30}$ or 680 lb.

387 “ 13, for 1% of 600 lb. read 0.85% of 680 lb.

399 “ 15, for ‘they are frequently contaminated with impurities’ read ‘blende as black-jack frequently contains iron.’

399 “ 16, omit ‘especially iron’.

403 “ 39, for 0.95% read 95%.

403 “ 40, for retained read recovered.

406 “ 21, for retort read condenser.

410 “ 35, for 1500°C . read 500°C .; for 550° read 85°C .; for boiling read melting.

420 “ 32 and 33, for ‘(1% of the whole) the zinc’ read ‘it’.

421 Omit line 2.

440 line 2, for 2.3 read 2.5.

449 “ 4, after ‘hydrofluosilicic’ insert ‘acid’, and for ‘is 8%’ read ‘contains 8%’.

469 Insert the sentence, lines 18 to 22 between lines 12 and 13.

470 Between lines 27 and 28 insert ‘Neutral basis, 10c. up or down’.

471 line 1, omit ‘Neutral basis, 10c. up or down’.

479 “ 15, for ‘operating’ read ‘power, repairs, renewals’.

484 “ 28, for 25c. read 25d.

484 “ 29, for $\frac{4.86}{240} \times \frac{25}{0.925}$ read $\frac{25}{240} \times 4.86 \times \frac{1000}{925}$

TABLE OF CONTENTS

PART I. GENERAL.

Section.	Page.
1. Ores, Definition and Classification.....	17
2. Metallurgical Treatment of Ores.....	19
3. Thermo-Chemistry as Applied to Metallurgy.....	20
4. Heat of Formation of Compounds.....	23
5. Combustion	24
6. Temperature of Combustion.....	29
7. Fuels	31
8. By-product Coke-Ovens or Retorts.....	40
9. Fuel or Producer-Gas.....	43
10. Refractory Materials.....	47
11. Sampling	55
12. Actual Sampling of Ore.....	56
13. Sampling Metals.....	64
14. Crushing and Grinding.....	66

PART II. ROASTING.

15. Oxidizing Roasting.....	79
16. The Chemistry of Roasting.....	79
17. Roasting Ores in Lump Form.....	84
18. Roasting Ores in Pulverized Condition.....	91
19. Hand-Operated Roasters.....	92
20. Mechanical Roasters.....	97
21. Roasting of Matte.....	110
22. Losses in Roasting.....	111
23. Capacity of Furnaces and Cost of Roasting.....	111
24. Blast or Pot Roasting of Ores.....	112

PART III. GOLD.

25. Gold Ores.....	117
26. Stamp-Mill Amalgamation.....	118
27. Operation of the Stamp-Battery.....	125
28. General Arrangement of a Gold Mill.....	130
29. California and Colorado Practice in Gold-Milling.....	133
30. Cost of Gold-Milling.....	134
31. The Hydrometallurgy of Gold.....	134
32. Chlorination of Gold Ores.....	136
33. Extraction of the Gold by Chlorination.....	138
34. The Vat or Plattner Process of Chlorination.....	139
35. Barrel Chlorination.....	143

TABLE OF CONTENTS.

Section.	Page.
125. Blowing-in the Blast-Furnace.....	377
126. Chemistry of the Blast-Furnace.....	378
127. Slags in Silver-Lead Smelting.....	381
128. Action of Various Bases in Slags.....	382
129. Fuel in Silver-Lead Smelting.....	384
130. Calculation of a Charge.....	385
131. Sampling and Handling Base-Bullion.....	390
132. Flue-Dust	391
133. Bag-House	392
134. Briquetting Flue-Dust.....	393
135. Lead-Copper Matte.....	395
136. Cost of Treatment of Lead Ores.....	395

PART VIII. ZINC.

137. Properties of Zinc.....	399
138. Zinc Ores.....	399
139. Metallurgy of Zinc.....	400
140. Roasting Blende.....	400
141. Chemistry of Roasting Zinc Ores.....	400
142. Roasting Furnaces.....	401
143. The Smelting or Distillation of Roasted Zinc Ores.....	402
144. The Zinc Furnace.....	404
145. Operation of the Furnace.....	405
146. Manufacture of Retorts and Condensers.....	408
147. Loss in Distillation.....	409
148. Cost of Smelting.....	410
149. The Sadtler Process.....	411

PART IX. REFINING.

150. Phenomena Underlying the Refining of Metals.....	415
151. Refining Lead Bullion.....	415
152. Softening.....	416
153. The Pattison Process.....	419
154. The Parkes Process.....	420
155. Variations in Methods of Refining Base-Bullion.....	429
156. Cost of Refining Base-Bullion.....	430
157. Copper Refining.....	430
158. Melting and Refining Lake Superior Copper.....	433
159. Electrolytic Copper Refining.....	434
160. Cost of Electrolytic Refining.....	437
161. Refining Impure Spelter.....	438
162. Parting Gold-Silver Bars.....	439
163. Refining Cast-Iron to make Wrought-Iron and Steel.....	440
164. Puddling Pig-Iron to make Wrought-Iron.....	441
165. Steel-Making by the Acid Bessemer Process.....	441
166. The Acid Bessemer Process.....	442
167. The Basic Open-Hearth Process.....	444
168. The Betts Process of the Electrolytic Refining of Lead.....	448

TABLE OF CONTENTS.

PART X. PLANT AND EQUIPMENT.

Section.	Page.
169. Primary Plant and Equipment.....	453
170. Location of Works.....	453
171. Installation of Plant and Equipment.....	456
172. Handling Materials	457

PART XI. COMMERCIAL.

173. Kinds of Works.....	467
174. Organization of a Metallurgical Company.....	467
175. The Purchase of Ores.....	468
176. Iron Ores	469
177. Ores Used in Silver-Lead Smelting.....	469
178. Schedule of Copper Ores.....	472
179. The Operating Department.....	473
180. Duties at a Large Gold Stamp-Mill.....	478
181. The Accounting Department.....	478
182. Labor Costs	480
183. Profits	481
184. The Selling Department.....	482
185. Fuels and Metal Market.....	482

LIST OF ILLUSTRATIONS

Fig.	Page.
1. Mahler Bomb Calorimeter.....	22
2. Wind Furnace.....	26
3. Cupola Furnace.....	26
4. Specific Heat of Gases.....	30
5. Table Showing Genesis of Natural Fuels.....	32
6. Table of Natural Solid Fuels.....	33
7. Section of Charcoal Kiln.....	37
8. Sections of By-Product and Beehive Coke Ovens.....	39
9. Sectional Elevation of Otto-Hoffman By-Product Coke-Oven Plant..	41
10. Taylor Revolving Bottom Gas-Producer.....	44
11. Loomis-Pettibone Gas-Making Plant.....	46
12. Brick Kiln.....	49
13. Brick Mold.....	52
14. Re-Pressing Machine.....	53
15. Pipe Ore-Sampler.....	60
16. Vezin Automatic Sampler.....	60
17. Sampling Works (Plan).....	61
18. Sampling Works (Elevation).....	61
19. Distribution of Silver in Bar of Base-Bullion.....	64
20. Base-Bullion Sampling Punch.....	65
21. Section of Bar of Ingot Copper.....	65

LIST OF ILLUSTRATIONS.

Fig.		Page.
22.	The Blake Ore-Crusher.....	70
23.	Blake Ore-Crusher (Section).....	71
24.	Crushing Rolls.....	72
25.	Flow-Sheet for Dry Crushing.....	73
26.	Trommel or Cylindrical Revolving Screen.....	74
27.	Roast-Yard with Trestle (Cross Section).....	85
28.	Roast-Yard with Trestle (Longitudinal Section).....	85
29.	Roasting Stalls for Lump Ore (Sectional Elevation).....	88
30.	Roasting Stalls for Lump Ore (Plan).....	89
31.	Reverberatory Roasting Furnace (Plan).....	93
32.	Reverberatory Roasting Furnace with Fuse-Box.....	93
33.	Reverberatory Roasting Furnace with Fuse-Box.....	95
34.	White-Howell Roasting Furnace.....	95
35.	Bruckner Roasting Furnace.....	98
36.	View of Wethey Roasting Furnace.....	101
37.	Cross-Section of Wethey Roasting Furnace.....	101
38.	Plan and Elevation of Edwards Roasting Furnace.....	102
39.	Cross-Section of Edwards Roasting Furnace.....	103
40.	Two-Deck Pearce-Turret Roasting Furnace (Plan).....	104
41.	Two-Deck Pearce-Turret Roasting Furnace (Elevation).....	105
42.	Detail of Rabblés.....	107
43.	McDougall Roasting Furnace (Elevation).....	109
44.	Perspective View of Ten-Stamp Battery.....	119
45.	Side Elevation of Ten-Stamp Battery.....	120
46.	Front Elevation of Ten-Stamp Battery.....	121
47.	Single-Discharge Mortar.....	122
48.	Double-Discharge Mortar.....	123
49.	Punched Screen.....	124
50.	Canda Cam.....	124
51.	Automatic Feeder.....	126
52.	Mercury Trap.....	127
53.	Clean-Up Pan.....	128
54.	Gold Retort.....	130
55.	Plan of Twenty-Stamp Mill.....	131
56.	Elevation of Twenty-Stamp Mill.....	132
57.	Table of Gold Ores.....	137
58.	Chlorination Leaching Vat.....	139
59.	Chlorine Generator.....	140
60.	Section Through Crushing Mill and Roaster.....	143
61.	Chlorination Barrel.....	144
62.	Section of Chlorination Barrel.....	145
63.	Precipitation Apparatus of Barrel Chlorination.....	148
64.	Flow-Sheet of Barrel Chlorination.....	151
65.	Elevation of Cyanide Plant.....	158
66.	Plant of Cyanide Plant.....	159
67.	Wooden Leaching Vat Showing False Bottom.....	160
68.	Perspective View of Wooden Leaching Vat.....	161
69.	Plan and Section of Wooden Leaching Vat.....	162
70.	Plan of Steel Leaching Vat.....	163

LIST OF ILLUSTRATIONS.

Fig.		Page.
71.	Section of Steel Leaching Vat.....	163
72.	Side Discharge Door.....	164
73.	Bottom Discharge Valve.....	165
74.	Sections of Zinc Boxes.....	166
75.	Perspective View of Zinc Boxes.....	167
76.	Floating Hose for Gold Solution Tank.....	168
77.	Zinc Lathe.....	169
78.	Filter Press.....	171
79.	Centrifugal Pump.....	173
80.	Elevation of Fifty-Ton Cyanide Plant.....	175
81.	View of Fifty-Ton Cyanide Plant.....	176
82.	Three-Compartment Spitzkasten.....	177
83.	Callow Classifying Cone.....	178
84.	Double-Cone Classifier.....	179
85.	Cyanide Plant for Double Treatment.....	181
86.	Tanks and Butters Distributor.....	182
87a.	Blaisdell Excavator.....	184
87b.	Sand Distributor, Blaisdell System.....	184
88.	Butters Filter Tanks.....	186
89.	General Elevation of Butters Filter Plant.....	187
90.	Ground Plan of Butters Filter Plant.....	187
91.	Cone Classifiers, Homestake Mill.....	189
92.	Elevation of Sand-Plant, Homestake Mill.....	190
93.	Plan of Sand-Plant, Homestake Mill.....	190
94.	Relation Between Mesh and Extraction.....	194
95.	Plan of Cyanide Treatment at El Oro, Mexico.....	195
96.	Gates Tube-Mill.....	196
97.	Elevation of Tube-Mill.....	197
98.	Plan of Operation of the Maitland Mill.....	200
99.	Single-Cone Classifiers.....	201
100.	Monadnock (Chilean) Mill.....	207
101.	Agitating Vat.....	212
102.	Wet Silver Mill.....	220
103.	Combination Amalgamating Pan.....	222
104.	Eight-Foot Settler.....	225
105.	Amalgam Safe.....	227
106.	Horizontal Retort and Melting Furnace for Silver Mill.....	228
107.	Boss-Process Silver Mill (Elevation).....	230
108.	Boss-Process Silver Mill (Plan).....	231
109.	Combination Stamp-Mill.....	233
110.	Dry-Crushing Silver Mill (Elevation).....	239
111.	Dry-Crushing Silver Mill (Plan).....	241
112.	Flow-Sheet of Augustin Process.....	249
113.	Flow-Sheet of Ziervogel Process.....	250
114.	Plan and Elevation of Lixiviation Plant for Silver Ores.....	254
115.	Sectional Elevation of Plant for the Lixiviation of Silver Ores.....	255
116.	Vat for Hyposulphite Lixiviation.....	256
117.	Flow-Sheet of Russell Process.....	261
118.	Sectional Elevation of Brown Agitator.....	265

LIST OF ILLUSTRATIONS.

Fig.	Page.
119. Sand-Treatment Chart and Record.....	269
120. Iron Blast-Furnace.....	275
121. Iron Blast-Furnace with Automatic Charging.....	276
122. Iron Blast-Furnace, Detailed Section.....	278
123. Cowper Hot-Blast Stove (Elevation).....	281
124. Cowper Hot-Blast Stove (Plan).....	282
125. Blowing Engine.....	285
126. Heyl and Patterson Pig-Casting Machine.....	287
127. Chemical Reactions of Blast-Furnace.....	289
128. Copper Smelting Plant.....	301
129. Blast-Furnace for Oxidized Copper Ores.....	303
130. Copper Matting Blast-Furnace.....	305
131. View of Copper Matting Blast-Furnace.....	306
132. Steel Water Jackets.....	307
133. Trapped Spout.....	308
134. Fore-Hearth	309
135. Slag Pot.....	310
136. Tuyere	311
137. Electric Trolley System.....	326
138. Reverberatory Smelting Furnace (Elevation).....	328
139. Reverberatory Smelting Furnace (Plan).....	329
140. Anaconda Reverberatory Furnace (Elevation).....	335
141. Anaconda Reverberatory Furnace (Plan).....	335
142. Copper Converter.....	337
143. Elevation of Smelting and Converting Plant.....	343
144. Plan of Smelting and Converting Plant.....	344
145. Wet Pan.....	345
146. Horizontal Blowing Engine.....	346
147. Hydraulic Accumulator.....	347
148. Cast-Steel Ladle.....	348
149. Henderson-Process Plant.....	357
150. Muffle Roasting Furnace.....	358
151. Ore Bed.....	363
152. Lead-Smelting Reverberatory Furnace (Plan).....	365
153. Lead-Smelting Reverberatory Furnace (Elevation).....	366
154. American Ore-Hearth.....	368
155. Globe Plant.....	370
156. Silver-Lead Blast-Furnace (Longitudinal Elevation).....	372
157. Silver-Lead Blast-Furnace (Transverse Elevation).....	373
158. Perspective View of Silver-Lead Blast-Furnace.....	374
159. End Water-Jacket with Knee-Bosh.....	375
160. End Water-Jacket, Straight.....	375
161. Cast-Iron Side-Jacket.....	376
162. Cast-Iron End-Jacket.....	376
163. Bag-House, Globe Smelting Works.....	393
164. White Briquetting Press.....	394
165. Zinc-Smelting Furnace (Section).....	404
166. Zinc-Smelting Furnace (Elevation).....	404
167. Zinc-Smelting Retorts.....	405

LIST OF ILLUSTRATIONS.

Fig.		Page.
168.	Charge Scoop.....	406
169.	Stamper	406
170.	Flow-Sheet of Lead Refining.....	417
171.	Softening Furnace.....	418
172.	Howard Mixer.....	421
173.	Howard Press.....	422
174.	Howard Press (Section).....	422
175.	Skimmer	423
176.	Molding Market-Lead.....	424
177.	Faber Du Faur Retort.....	425
178.	English Cupelling Furnace.....	426
179.	English Cupelling Furnace (Detailed Sections).....	426
180.	Test for English Cupelling Furnace.....	428
181.	Stirring Paddle.....	430
182.	Sectional Elevation of Copper Refining Furnace.....	431
183.	Plant of Copper Refining Furnace.....	431
184.	Section of Bessemer Converter in Upright Position.....	442
185.	Acid Bessemer Blow, American Practice.....	444
186.	Longitudinal Section and Elevation of Open-Hearth Furnace.....	445
187.	Sectional Plan of Open-Hearth Furnace.....	446
188.	Chemical Changes in Basic Open-Hearth Presses.....	447
189.	Vertical Belt Elevator.....	458
190.	Steel Elevator Bucket.....	459
191.	Single-Strand Endless-Chain Elevator.....	460
192.	Double-Strand Endless-Chain Elevator.....	460
193.	Conveying Belt with Tripper.....	461
194.	Screw Conveyor (Quarter Turn).....	462
195.	Endless-Chain Push Conveyor.....	463

PREFACE TO FIRST EDITION

This outline of the metallurgy of the common metals, namely, gold, silver, iron, copper, lead, and zinc, is devoted to the description of processes for winning these metals from their ores and then refining them. The metallurgy of iron is treated only to the point where pig-iron is obtained.

Following the description of ores, as well as of the fuels used in smelting them, and the materials of which the furnaces are constructed, we come to sampling, for the determination of the exact value of the ore before treatment.

A chapter has been devoted to the subject of thermo-chemistry as applied to igneous methods of extraction. The winning or reduction of the various metals is then taken up in order, and is followed by a description of the methods of refining them. Attention is then given to commercial considerations, since the processes must be conducted in a profitable way.

The author is indebted to Mr. F. L. Bosqui, who has not only read the manuscript, but has modified the portion devoted to the cyaniding of gold and silver ores, as his special knowledge has justified. For the subject matter relating to the smelting of silver-lead and copper ores, the author has drawn on his own experience, gained during a quarter of a century of practical work.

L. S. AUSTIN.

Houghton, May 1, 1907.

PREFACE TO SECOND EDITION

The experience gained in using the first edition has suggested many changes, and the book has accordingly been re-written, adding new matter, describing other processes, and keeping step with modern practice.

In Part I the subject of thermo-chemistry has been expanded, and a table of heats of formation given. The description of the cyanide process has been amplified and brought up to date, for milling methods are being rapidly improved, and cyanidation is having increased application, especially in the treatment of silver-bearing ores. The metallurgy of zinc has been treated more fully,

and particular attention given to the principles underlying the smelting of zinc ores.

In the part devoted to refining there has been added the making of wrought-iron and steel, the refining of zinc, and the electrolytic refining of lead.

Plant and equipment is placed in a separate chapter, while the division describing the economics of metallurgy has been thrown into a more systematic form. The author is indebted to Mr. E. A. Hersam, who read the manuscript of the second edition and made numerous suggestions and corrections.

The author is indebted to the following companies for the use of certain of the illustrations in this book: Allis-Chalmers Co., Milwaukee, Wis.; Power & Mining Machinery Co., Cudahy, Wis.; Chisholm, Matthew & Co., Colorado Springs, Colo.; F. M. Davis Iron Works Co., Denver, Colo.; Stearns-Roger Mfg. Co., Denver, Colo.; Pacific Tank Co., San Francisco, Cal.; Redwood Manufacturers Co., San Francisco, Cal.; Galigher Machinery Co., Salt Lake City, Utah; Traylor Engineering Co., Allentown, Pa.; Blaisdell Co., Los Angeles; Cal.; Denver Engineering Works Co., Denver, Colo.; Trent Engineering & Machinery Co., Salt Lake City, Utah; Risdon Iron Works, San Francisco, Cal.; Colorado Iron Works Co., Denver, Colo.; Cyanide Plant Supply Co., Ltd., London; The Jeffrey Mfg. Co., Columbus, Ohio.

L. S. AUSTIN.

Houghton, August 1, 1909.

PART I. GENERAL

PART I. GENERAL.

1. ORES. DEFINITION AND CLASSIFICATION.

An ore may be defined as a mineral aggregate containing a metal, or metals, in sufficient quantity to make extraction commercially profitable. Minerals or rocks containing 15 to 30% iron would not be called iron ore, nor would we call a rock containing 2 to 3 oz. silver per ton a silver ore. Nevertheless, the rock of the Treadwell mine, on Douglas Island, Alaska, carrying \$2.50 to \$3 in gold, is called a gold ore because it can be worked at a profit. In general, ores are named from their chief mineral constituent, as lead, copper, or silver ores, though they may contain other metals. Thus a lead ore may contain silver and gold; a copper ore, besides copper, may contain silver, gold, and even lead. The appearance of an ore may indicate whether it carries lead, copper, iron, or zinc, but gold and silver are not always visible, and the proper way to determine their presence is by assay. An ore containing little lead, say less than 5%, is designated a dry ore. Such ore is often silicious, but may possess value because it contains gold and silver. Ores carrying more than 5 to 10% lead may be profitably treated for their lead. Copper ores containing 5 to 10% copper also frequently contain gold and silver.

Straight or simple ores contain in the main but one kind of metal, such as gold, silver, copper, or lead. Straight silver, or free-milling silver ores, are free from lead and copper, and may be treated by amalgamation. Straight gold ores, also free-milling, are those containing the gold in metallic form and amenable to amalgamation. Straight or plain lead, zinc, or copper ores do not contain gold or silver in quantity sufficient to pay to separate the precious metals from the base metal. As an example, a lead ore containing 4 oz. silver per ton would not ordinarily meet the cost of extracting the silver. Blister copper may contain as much as 16 oz. silver per ton and yet not pay the cost of electrolytic refining for its recovery.

Mixed ores, or those containing two or more kinds of metal, are common, such as silver-gold, silver-gold-lead, or lead-zinc-copper-silver. When such ores contain both copper and lead it is puzzling

at times to know how to designate them. In doubtful cases smelting companies have purchased them either on the basis of their lead or copper content, under the plea that, in extracting one of these metals, the other is lost or wasted. Lead-silver or lead-silver-gold ores are those which carry lead in such quantity that when the lead is recovered from them by smelting, the precious metals alloy with it, and can be later easily removed from the lead. Copper-silver, copper-silver-gold, or copper-gold ores, when smelted, yield their copper, and this, like lead, takes up the precious metals.

Base-metal ores.—Lead and copper ores often contain zinc, antimony, arsenic, tellurium, or bismuth. These, in the process of reduction, alloy with the principal metal to its commercial detriment, and require expensive after-treatment. While a free-milling ore permits the extraction of most of its gold or silver by simple processes of grinding and amalgamation, a refractory or rebellious one requires preliminary treatment by roasting before it can be amalgamated; otherwise it must be smelted. Even smelting ores may present difficulties of treatment that would require them to be called rebellious. A docile ore, on the contrary, is one that may be easily treated. Gold and silver ores containing arsenic or antimony may be cited as examples of refractory ores.

As respects treatment, we may have free-milling, leaching, chloridizing, cyaniding, or smelting ores. The latter, or smelting ores, may be basic, silicious, dry, coppery, or leady ores; while the former kinds may be talcose, quartzose, raw, roasting, earthy, argillaceous, light, heavy, or base, all of which characteristics modify the mode of treatment. Among the iron ores we may have bessemer ores or those containing a minimum of phosphorus, and non-bessemer, or those so high in phosphorus as to require treatment in the basic open-hearth furnace.

An ore consists not only of the species of metallic compound from which it is named, but also of gangue or waste matter. This may often be its principal constituent, and may be earthy, silicious, argillaceous, talcose, or limy, and the ore may be composed largely of the lighter gangue with comparatively small quantities of the valuable metals scattered or disseminated through it. When, as is often the case, the metal is the heavy part of the ore, and the lighter part is the gangue, the ore may be concentrated or dressed with a view to removing this gangue. An ore capable of being thus treated is called a concentrating ore, and the valuable heavy part obtained from it is called a 'concentrate'.

We may also divide ores into sulphide and oxidized. As a mat-

ter of fact, these merge into one another, and it is often difficult to decide to which class to assign a given ore. Carbonates are placed among the oxidized ores, since, in smelting, the carbon dioxide is readily driven off, leaving the oxide of the metal.

Grading ore.—Miners often find it profitable to sort their ore into different grades, such as shipping or smelting, and into milling or concentrating ore, according to the after-treatment they propose to give it. This matter is often an important one for the metallurgist to consider in deciding upon the treatment of ore, as, for example, in the case of a mixed silver ore, by the 'combination method'.

2. METALLURGICAL TREATMENT OF ORES.

In winning or reducing metals from their ores, the ideal treatment may be divided into three stages: Preparation, Extraction, Segregation.

(1) **Preparation.**—This has reference to the operations by which the ore is fitted to undergo later treatment. Thus, the ore may be broken, crushed, or comminuted to make the metallic compound accessible to a solvent solution. Or again, the ore may have to be roasted to render it capable of being reduced to metal.

(2) **Extraction.**—This consists in having present, or in adding to the prepared ore or mineral, a collector, the duty of which shall be to receive or take up the metal in the ore, reducing it to a small bulk from which the metal is easily separated in the third operation. The collector may be one of the metals in molten condition (mercury, lead, or copper), or water, or some solution.

(3) **Segregation.**—This consists in removing, by precipitation or concentration, the metal thus absorbed by the collector, whereby the metal itself is brought into marketable form. This does not necessarily mean refining, for the metal may contain impurities and still be in marketable form.

As an instance of such a three-fold treatment we may take the extraction of gold from a free-milling gold ore. In the first stage the ore is finely crushed to unlock the particles of gold. In the second operation these gold particles are arrested on a mercury-covered or amalgamated surface, the mercury acting as a collector. In the final stage, the collected gold, together with the mercury from the plate, is recovered by distilling the mercury, leaving the gold behind. Again, silver-bearing sulphide ore, without preliminary roasting, may be melted in a furnace with a lead-bearing ore. As the lead ore is reduced it collects the silver in the silver ore with which it was

mixed, thus producing a silver-bearing lead. The silver may be later separated from the lead in commercial form.

The two first operations may be combined into one. Thus, iron ore is treated in the blast-furnace. In the upper zone, water and carbon dioxide are driven off. The iron is next reduced, collecting the metalloids carbon and silicon to form pig-iron. Finally, these metalloids may be separated, and the pig-iron made into steel.

3. THERMO-CHEMISTRY AS APPLIED TO METALLURGY.

Thermo-chemistry treats of the heat evolved or absorbed as the result of the combustion of fuel, and the chemical reactions in metallurgy.

In cupellation, air passing over the surface of molten lead, oxidizes the lead with the evolution of heat. Hydrogen and oxygen in a closed vessel, ignited by an electric spark, unite with much energy, forming the vapor of water, and producing much heat by the reaction. Steam passed through a glowing coke fire is decomposed, forming hydrogen and carbon monoxide, but absorbing heat and rapidly cooling the fire.

The heat generated by the formation of many chemical compounds has been determined, the unit by which it is measured being the heat required to raise a unit-weight of water one degree. The different units are as follows:

One gram of water raised 1°C., called the small calorie (cal.).

One kilogram of water raised 1°C., called the large calorie (Cal.).

One pound of water raised 1°C., called the pound-calorie (lb. cal.).

One pound of water raised 1°F., called the British thermal unit (B. t. u.).

The gram-calorie being too small for practical application, it has been customary to use the large calorie or Calorie, one thousand times greater. In the calculations that follow, the pound-calorie will be used, since the weights are given in pounds, and the numbers used in the kilogram system remain unchanged.

The chemical equation

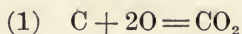

means that one equivalent (12 lb.) of carbon is burned with two equivalents (32 lb.) of oxygen, producing carbon dioxide (44 lb.), and evolving 97,000 pound-calories or 8080 heat units per pound of carbon burned to carbon dioxide. In writing equations the molecular weight is understood as in ordinary chemical equations. The above may also be written

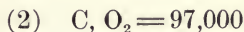

with a comma to indicate that the different molecules, so separated, unite to form CO_2 .

If oxygen burns in presence of an excess of highly heated carbon, then carbon monoxide is formed, and this may be written

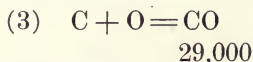

which indicates that by the combination of the solid carbon with the gaseous oxygen 29,000 calories have been formed. Likewise this may be written

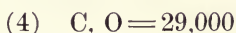

Since the 12 lb. carbon gives 29,000 calories, we have, as the heat evolved by the burning of one pound of carbon, 2440 calories. If we burn the CO thus formed with a sufficient amount of air, we have

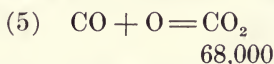

or, as also written, $CO, O = 68,000$ calories. Were this written C, O_2 then we would have 97,000 cal. (Equation (2)).

Equation (5) may again be written

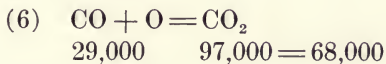

This means that before this reaction can take place, the CO must be broken up according to the reaction,

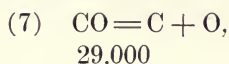

or again

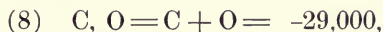

the minus sign meaning that in this reaction as much heat has been absorbed in the breaking up as was earlier evolved in equation (3), in which these elements united.

In equation (6) the CO having been decomposed into C and O, they are forced to unite with the O to form CO_2 , evolving 97,000 cal. The net result or the algebraic sum of the two reactions is thus 68,000 cal. as given in equation (6).

1. **The amount of heat needed to decompose a compound into its constituents is equal to that evolved when that compound is formed from those constituents.** When a reaction takes place by which heat is absorbed, as in equation (8), it is called 'endothermic'. On the other hand, when heat is evolved in a reaction, as in equations (1), (3), and (5), it is said to be 'exothermic'.

2. The heat evolved in a chemical process is the same, whether it takes place directly or in several steps. Thus in equation (3) the carbon is burned to CO with the evolution of 29,000 calories. The CO thus formed, when burned with additional oxygen, as in equation (5), gives 68,000 calories, and the sum of these two is 97,000 cal., the same as if the carbon had been burned to CO_2 as per equation (1).

In comparing reactions (1) and (3), it may be said that in presence of an excess of oxygen, reaction (1) would take place rather than reaction (3). This is in accordance with the law of Berthelot, namely:

(3) Every reaction which takes place independently of the addi-

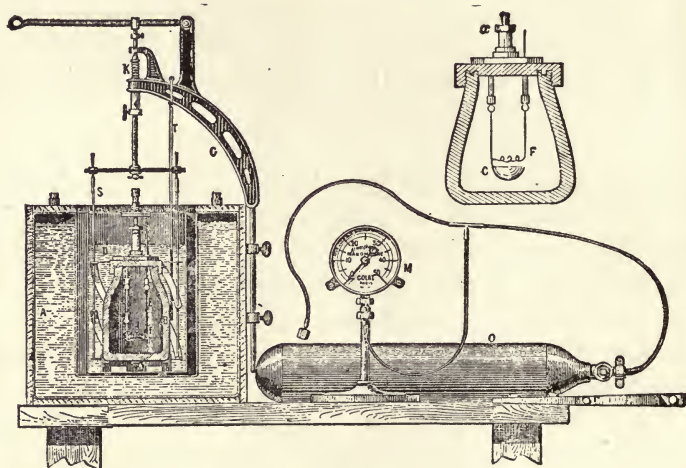

Fig. 1. MAHLER BOMB CALORIMETER.

tion of energy from without the system, tends to form the combination which is accompanied by the greatest evolution of heat.

To determine accurately the heats of combustion of fuels, or the heat of formation of compounds, the Mahler bomb-calorimeter, Fig. 1, is much used. It consists of a steel shell or bomb, marked *B*, shown also on an enlarged scale at the right-hand upper corner of the illustration. The bomb, holding about a pint and weighing 9 lb., is shown to be closed by a screw-cap, having a stop-cock threaded connection *x* by which it may be connected by a flexible pipe to a cylinder *O*, which contains compressed oxygen gas. Within the bomb is suspended a capsule *c* in which is placed a gram of the substance to be tested. The cap is then tightly screwed on, and oxygen gas under 300 lb. per sq. in. is allowed to enter. The shell is placed in the

calorimeter *D*, which contains a known weight of water. The thermometer *T* is set in place, and the stirrer or agitator *s* is set in motion to bring the whole apparatus to the same temperature. The calorimeter *D* is placed within a larger vessel *A* covered with a thick layer of felt and provided with a thermometer (not shown). The vessel *A* serves also to support the bracket *G* from which the stirrer is suspended. The temperature of the calorimeter having been noted, the charge is ignited by a coil of the platinum wire *F* (See enlarged view). The resultant rise in temperature is noted by the thermometer *T*. The total heat developed with certain corrections, is calculated from the weight of the calorimeter water, and from the rise in temperature. In those cases where the heats of formation of oxides or of silicates are desired, the result is accomplished by respectively oxidizing or melting them in the bomb with a known weight of a well-determined fuel. The number of calories evolved are the algebraic sum of those of the desired reaction and that of the fuel.

Following are the molecular weights and the heats of formation of some of the better known chemical compounds. From these may be estimated the heat developed in various reactions.

4. HEAT OF FORMATION OF COMPOUNDS.

Formula.	Molecular weight.	Heat of formation. (in calories).
MgO	$24 + 16 = 40$	143,400
CaO	$40 + 16 = 56$	131,500
Al ₂ O ₃	$55 + 48 = 102$	392,600
MnO	$55 + 16 = 71$	90,900
FeO	$56 + 16 = 72$	65,700
Fe ₂ O ₃	$112 + 48 = 160$	195,600
PbO	$207 + 16 = 223$	50,800
ZnO	$65 + 16 = 81$	84,800
CuO	$63.6 + 16 = 79.6$	37,700
Cu ₂ O	$127.2 + 16 = 143.2$	43,800
Sb ₂ O ₅	$240 + 80 = 320$	231,200
As ₂ O ₅	$150 + 80 = 230$	219,400
Ag ₂ O	$216 + 16 = 232$	7,000
Na ₂ O	$46 + 16 = 62$	100,900
K ₂ O	$78 + 16 = 94$	98,200
SiO ₂	$28 + 32 = 60$	180,000
CO ₂	$12 + 32 = 44$	97,000
CO	$12 + 16 = 28$	29,000 (gas)

Formula.	Molecular weight.	Heat of formation. (in calories).
H ₂ O	2 + 16 = 18	70,400 (solid) 69,000 (liquid) 58,060 (gas)
CaS	40 + 32 = 72	94,300
ZnS	65 + 32 = 97	43,000
FeS	56 + 32 = 88	24,000
Cu ₂ S	127.2 + 32 = 159.2	20,300
CuS	63.6 + 32 = 95.6	10,100
PbS	207 + 32 = 239	20,200
Sb ₂ S ₃	240 + 96 = 336	34,400
Ag ₂ S	216 + 32 = 248	3,000
Ba, C, O ₃	137 + 12 + 48 = 197	286,300
Ca, C, O ₃	40 + 12 + 48 = 100	273,800
Mg, C, O ₃	24 + 12 + 48 = 84	269,900
Ca, Si, O ₃	40 + 28 + 48 = 116	329,350
Al ₂ , Si, O ₇	54 + 56 + 112 = 222	767,500
Mn, Si, O ₃	55 + 28 + 48 = 131	276,300
Fe, Si, O ₃	56 + 28 + 48 = 132	254,600
Na ₂ , S, O ₄	46 + 32 + 64 = 142	328,100
Ca, S, O ₄	40 + 32 + 64 = 136	317,400
Mn, S, O ₄	65 + 32 + 64 = 151	249,400
Zn, S, O ₄	65 + 32 + 64 = 161	248,000
Fe, S, O ₄	56 + 32 + 64 = 152	234,900
Fe ₂ , S ₃ , O ₁₂	112 + 96 + 192 = 400	650,500
Pb, S, O ₄	207 + 32 + 64 = 303	215,700
H ₂ , S, O ₄	2 + 32 + 64 = 98	192,200
H ₂ , S, O ₄	in dilute solution	210,200
Cu, S, O ₄	63.6 + 32 + 64 = 159.6	181,700
Ag ₂ , S, O ₄	216 + 32 + 64 = 312	167,100
x Hg, Au	x + 197 = 197 + x	2,580
x Hg, Ag	x + 108 = 108 + x	2,470

5. COMBUSTION.

Combustion, as generally understood, may be defined as a vigorous chemical combination, attended with the production of light and heat. To start combustion, the fuel must be (1) **brought to the temperature of ignition**; (2) **it must be maintained at this temperature**; (3) **a sufficient supply of air must be provided**; and (4) **the products of combustion must be removed**.

A jet of gas, burning as it issues from a tube, begins to take fire

one or more inches from the tube, and continues to burn as rapidly as the molecules of the gas come in contact with those of the air. In an open-hearth furnace a current of heated gas and one of air mingle gradually, and do not become fully mixed and inflamed until a few feet from the outlet ports. It is the same in a reverberatory furnace, especially where there is but little more air than required for perfect combustion. The furnace, even if 100 ft. long, is filled with flame from end to end, showing that gas at the distant end is still combining with air and burning. If, in the fire-box of such a furnace, we carry a thick fire, not less than 18 to 24 in. deep, the air passes through the fire freely. The flame is then shorter, since the hydrocarbon gas is speedily consumed. The long flame is desirable where we wish to extend combustion through the furnace and not to produce so intense a heat near the fire. Cases sometimes occur when, upon the stopping of a blast-furnace, the carbon monoxide gas from the furnace works back into the blast-main, and forming with the air an explosive mixture, is ignited from the hot fuel, and explodes with sufficient violence to break the main. If fuel-oil be fed into an oil-burner or injector, where it is broken up by a jet of steam or air into a fine spray, and then blown into a red-hot combustion chamber, it will burn like gas with an intense heat. Finely-powdered coal projected in the same way, and with a sufficient supply of air (preferably pre-heated) burns rapidly, resembling gas, and furnishes abundant heat and high temperature.

Thus, to promote rapid combustion, the fuel must be in such form as to afford plenty of contact to the air. A piece of charcoal of large size burns readily, because, being porous, the air readily finds a way to penetrate it; while a lump of anthracite, being dense, burns more slowly. Paper and kindling wood expose a large surface to air, and hence ignite readily and burn rapidly. Paper in books, and fabrics in bales, burn with difficulty. They may pass through fire only singed on the outside. Light lumber and boards burn readily, while heavy beams of wood resist a severe fire, with only superficial charring. A thick layer of sawdust or fine coal, thrown on a fire, may extinguish it. Hence, in firing up, such fine materials should be added sparingly, and used with lump coal or pieces of wood, to make passages or cavities, through which the air may pass. Finally, as may be seen, a common error made in fire-building is that while an abundant supply of fuel may be present, insufficient provision is made for the free passage of air through the fuel. A good draft and a sufficiently large exit-flue must be provided to carry away the products of combustion.

Flame is gas undergoing combustion. Soft coal and wood burn with a flame because the heat from burning distills, or drives out, the hydrocarbon gas which is formed. Anthracite, coke, or charcoal burns with little or no flame; while hydrogen burns with a non-luminous, though very hot flame.

As an illustration of what takes place in a deep fire, let us consider a fire of glowing coke, Fig. 2. Here the air enters through the

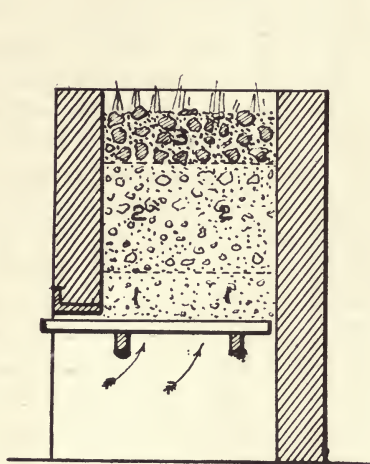

Fig. 2. WIND FURNACE.

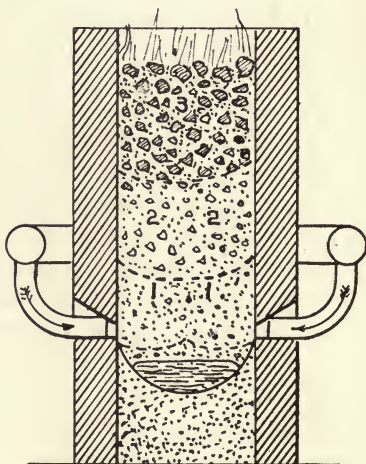
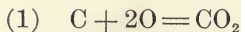

Fig. 3. CUPOLA FURNACE.

grate-bars, and, at the first instant, in contact with the glowing fuel, produces carbon dioxide,



with the development of a large amount of heat. Between two and four inches above the grate (with a clear fire) we may expect to find the highest temperature. This forms the zone 1, Fig. 2, and hence in a crucible furnace the bottom of the crucible should be set 4 in. above the grate to get the full effect of the heat of the fire.

As we go upward, the CO_2 in excess acts on the glowing carbon and dissolves or combines with it as follows:

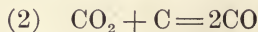

This reaction is accompanied by the absorption of heat, and thus zone 2, Fig. 2, is cooler than the one below. In the zone 3, no reaction takes place, the fuel being simply heated by the ascending gases. A little air may pass along the walls, and issuing above the surface of

the fuel, and mixing with the CO gas, burn a small portion of it to carbon dioxide with a blue flame thus:



This reaction also is a heat-producing one.

We finally get, with a thick fire, a mixture of gases of a composition much like the following:

N 70%, CO 25%, CO₂ 2.5%, O 0.5%, and H 1.0%.

The presence of the hydrogen is due to the decomposition of the moisture in the air. This mixture of gases can be made in a gas-producer (See Fig. 10), and for that reason it is called producer-gas. Because of its content of CO it can be burned according to equation (3), and used as a fuel for any purpose of heating. To completely burn the gas, and to get the most heat from it, the thickness of the fire should not be greater than is shown in zone 1, Fig. 2.

Fig. 3 represents a foundry-cupola charged with alternate layers of coke and pieces of pig-iron. Here the object is to melt the iron, collecting it in a pool or bath at the bottom in the crucible of the furnace, shown in the illustration. Air is forced into the furnace, and fills all the voids, rising through the charge chiefly in the passages or openings offering the least resistance. In an iron blast-furnace (See Fig. 121) the rate of upward velocity approximates 6 ft. per second. As air meets the burning coke, combustion takes place according to equation (1), producing a white heat. This action, in a cupola of 36 to 48 in. diam., extends upward about 3 ft. from the tuyeres, the upper limit of zone 1, Fig. 3. As the gases enter the zone 2, the CO₂ just formed is decomposed by contact with the hot coke and forms CO, according to reaction (2), the change being nearly complete at the upper limit of zone 2. In the upper zone no change takes place in the gases, and they impart their heat to the cold charge, which is being supplied as fast as the ore sinks below the required level. In this cupola, where the operation is one only of melting, to attain the greatest economy of fuel, the coke should be dense, the pieces large, and the blast abundant to supply plenty of air. Thus, burning the coke is deferred to the last, less CO is formed, and the combustion, performed largely in zone 1, is more nearly complete, developing the largest possible amount of heat.

From equation (1) we find, that to burn one pound of carbon to CO₂, and thus with the greatest development of heat, there is needed 2.66 lb. oxygen, or 11.6 lb. air, since air contains 23% oxygen by weight. At the sea-level 12.4 cu. ft. air weigh one pound. This makes 143.8 cu. ft., or, in round numbers, 150 cu. ft. air per pound

of carbon. Ordinary coke contains 85% carbon, thus requiring 122 cu. ft. air per pound of such coke. While in theory 12 lb. air should be sufficient per pound of coal, it has been found that excess is needed for complete combustion. For natural draft, using a thin fire, 18 to 24 lb. air has given the most satisfactory results, and where air is forced into a closed ash-pit, and through the fire-bed (undergrate blast), then 16 lb. air, or even less, is sufficient.

Figuring from equation (2) in the same way, we find, per pound of carbon 1.33 lb. of oxygen required, or of air 5.79 lb., equal to 71.8 cu. ft. Upon the basis of coke containing 85% combustible matter, 61 cu. ft. air are required per pound of fuel when burned to CO.

Chimneys or stacks.—In a furnace reaction not only is it necessary that the reacting elements be present in mutual contact, but that the products of the reaction be removed as fast as formed. Under conditions other than this the reaction ceases. A draft, therefore, must be provided, to carry away the waste gas, and to expel it into the atmosphere. This draft may be natural or forced. To insure obtaining a sufficient draft in a chimney, the gases must be delivered into the stack while hot. A temperature of 200°C. is ample for this, but since the work of most furnaces is done at a temperature higher than a red-heat, the excess may be utilized to generate steam by conducting the gases through waste-heat boilers before entering the stack.

In a reverberatory-furnace, used for smelting, the quantity and intensity of the heat depend upon the amount of coal burned per hour. This varies between 18 and 40 lb. per square foot of grate area and, to completely burn it, there will be needed 150 cu. ft. air per pound of coal consumed. In these furnaces the gases escape at temperatures between 300° and 1100°C., and move with a velocity of 12 to 20 ft. per second. For illustration, take the furnace Fig. 138 and 139, with a grate-area of 56 sq. ft., a consumption of 30 lb. of coal per square foot of grate-area per hour, needing 252,000 cu. ft. of free air. Allowing a temperature in this instance of 1000°C., and a draft velocity of 20 ft. per second at this high temperature, and knowing that these gases expand $\frac{1}{273}$ of their volume for each degree above 0°C., we find the volume at 1000°C. to be $\frac{1000 + 273}{273} = 4.7$ times the volume at 0°C. Assuming the temperature of the outside air to be 0°C., we shall have as the volume of hot gas per hour 1,184,400 cu. ft. At 20 ft. per second, or 72,000 ft. per hour, this will be an area of stack of $\frac{1,184,400}{72,000} = 15$ sq. ft. The actual area is 16 square feet.

The total pull, or suction, that a chimney can produce, assuming it to be filled with hot gases, is due simply to the ascensive force of the gas measured by the difference between its weight and the weight of an equal volume of the cold air outside. To maintain the velocity of the gas in the stack, it has been found that a suction, or 'pull', of 0.4 to 0.8 in. of water, as measured by a water-gauge, is needed. Taking a draft of 0.6 in. in the above instance and adding 0.1 in. for friction in the chimney, we have 0.7 in. water equal to $\frac{62.5 \times 0.7}{12 \times 6.25} = 3.647$ lb. per sq. ft. A cubic foot air at 0°C . weighs 0.0807 lb. (12.4 cu. ft. per lb.). The gas inside the stack has a specific gravity of 1.03, weight of air being unity, thus making the weight when heated $\frac{0.0807 \times 1.03}{4.7} = 0.0177$ lb. per cu. ft. Hence we have the difference (0.0807—0.0177=0.063) as the ascensive force per foot of height. The stack should therefore be $\frac{3.647}{0.063} = 58$ ft. or approximately 60 ft. high.

From the above calculation it appears that the draft-pressure varies with the temperature, and height of the chimney. The velocity of the gas, or the amount of air passing through the fire per hour at a given temperature, varies as the square root of the height of the stack, in accordance with the equation $V = \sqrt{2gh}$; g being acceleration due to gravity and h head in feet. Thus a stack 100 ft. high would increase the velocity only 1.31 times more than our 58-ft. stack calculated above. The volume of gas increases directly with the temperature, while the velocity varies with the square root of this, hence there is a point of maximum discharge, at 273°C . At a higher temperature, while the velocity increases, the weight of the gas on the contrary diminishes.

6. TEMPERATURE OF COMBUSTION.

By this is meant the temperature of gases resulting from combustion under ordinary atmospheric pressure. We can calculate this when we know the calorific power of the fuel, and the total weight and mean specific heat of the resultant gases. The specific heat between 0°C . and the temperature of combustion increases as is shown in the diagram next shown.

As an example of the use of the following table, let us find the maximum temperature of combustion obtained in burning one pound of coke of 85% carbon, using the theoretical amount of air or 9.77 lb. (since pure carbon requires 11.6 lb.), neglecting the loss of heat in the adjoining walls of the furnace. Since by weight there is 87% nitrogen in air, there will be, in the mixed gas resulting from com-

7.6
 bustion, 8.5 lb. nitrogen, and 3.11 lb. CO₂ (0.85 lb. carbon, and $\frac{32}{12} \times 0.85 = 2.26$ lb. oxygen). We assume a temperature of 2000° C., which is as near the desired one as we can estimate at this time.

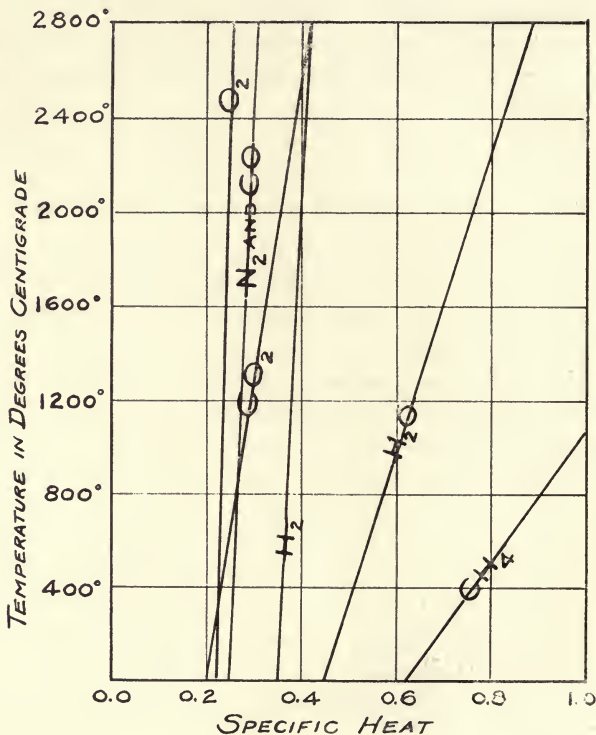

Fig. 4. SPECIFIC HEAT OF GASES.

Fig. 4 for 2000° the specific heat
 From the table we find the heat values to be, for N₂, 0.251 and for CO₂, 0.364. We then have:

7.6
~~8.5~~ lb. nitrogen @ 0.251 = 2.133
 3.11 lb. carbon-dioxide @ 0.364 = 1.132

3.265

The number of calories necessary to raise the entire gaseous product one degree will then be 3.265. The heat developed by the burning of the coke, being 6800 cal., the temperature of combustion is $\frac{6800}{3.265} = 2080^\circ\text{C}$. The specific heat of the gases at this temperature being so nearly that at 2000°C. we can use it in this calculation. Were the

difference great, we should have to use the specific heat at the exact temperature and calculate again upon that basis.

To proceed further, let us find the temperature of combustion, or flame-temperature of carbon monoxide burning to carbon dioxide:

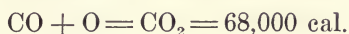

$$28 + 16 = 44$$

One pound of CO will produce 2440 cal., and will take 0.572 lb. oxygen or $\frac{0.572}{0.23} = 2.48$ lb. air containing 1.91 lb. nitrogen. There is also 1.57 lb. CO₂ produced. Taking the specific heats from the table, Fig. 4,

$$1.91 \text{ lb. nitrogen} \dots\dots\dots @ 0.287 = 0.548 \text{ cal.}$$

$$1.57 \text{ lb. carbon-dioxide} \dots\dots\dots @ 0.364 = 0.572 \text{ "}$$

$$1.120 \text{ "}$$

for each degree of rise in temperature. Hence $\frac{2440}{1.12} = 2200^\circ\text{C.} =$ the temperature of combustion. Again, calculating with the increased specific heat of the newly found temperature (2200°), we find 2112 to be the exact number of calories, nearly identical with that already found.

7. FUELS.

A fuel may be defined as a solid, liquid, or gaseous substance that can be burned for the production of heat for economic purposes. Fuels can be divided into two classes: natural and artificial. Coal is a natural fuel; coke is an artificial one. The natural fuels include 'natural gas', the 'mineral oils', and 'solid fuel' like wood or coal. The solid natural fuels are believed to be of vegetable origin. They are substances in some measure altered from their original condition by heat and pressure, and range from wood through peat, lignite, bituminous or soft coal, anthracite or hard coal to graphite at the extreme. Artificial fuels may be divided into the 'solid prepared fuels' and 'fuel gas'. The solid fuels are coke and charcoal.

The relation of the natural carbonaceous substances is shown in Fig. 5. Here in a general way is illustrated the chemical and physical changes that occur in the formation of coal from its organic constituents in plant-tissue. These changes result, finally, under the action of pressure and high temperature, in graphitic carbon, and begin by action upon wood, leaves, and root-fibers (turf or peat), passing through lignites or freshly formed coal, often brown in color, thence to bituminous coal formed during recorded geological time, retaining the volatile constituents, to anthracite where the volatile constituents are mostly eliminated by the heat and immense

pressure, and finally result in graphite where distillation completes the work.

Wood.—When freshly cut, wood contains 40% moisture and in this condition is difficult to burn alone; but where this can be done, it develops 2300 pound-calories per pound. Split into cord-wood, piled, and dried for several months, wood contains 20% moisture and 40% carbon. Its calorific value thereby increases to 3100 calo-

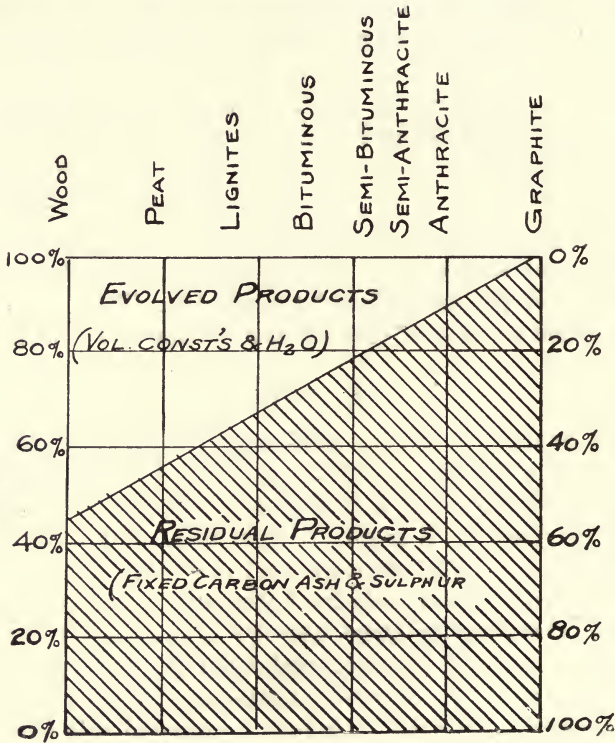

Fig. 5. TABLE SHOWING GENESIS OF NATURAL FUELS.

ries. Such wood is classed as hard when its specific gravity is more than 0.55; below this it is called soft. While the calorific intensity of dry wood is low, its combustibility is great, and it is well suited for use in reverberatory roasting-furnaces, since the volatile constituents, rapidly escaping, burn gradually, and make an extended flame along the hearth of the furnace, heating it more uniformly than could a flameless fuel like anthracite or coke. In the outlying districts of the western United States, where the metallurgist is dependent on wood for generating steam, or roasting ore, the accu-

mulation of a sufficient supply of dry wood should be one of his first cares. In this his forethought is well rewarded. He should purchase wood delivered and corded near the works; and in measuring, make equitable allowance for short dimensions or open piling. Cord-wood should 'cord up' to 70% solid wood.

Peat.—This is the product of the slow decay of plants under natural conditions and the exclusion of air. It is extremely variable in water and ash, but the best air-dried peat retains 25% moisture, while the ash may vary from 1 to 30%. Its calorific power does not exceed 3000 calories per pound.

Lignite.—This fuel occupies an intermediate place between peat and true coal. Four distinct types can be specified. These are: (1) fossil-wood or fibrous brown-coal, which has a distinctly woody texture; (2) earthy lignite, without structure and earthy in fracture; (3) conchoidal lignite, with a conchoidal fracture; and (4) bituminous lignite, a black, shiny fuel having also a conchoidal fracture. When recently mined, lignite contains 33% or more moisture, but when air-dried, it loses half or more of this (See C in table of natural fuel, Fig. 6). The ash ranges from 3 to 30%. Lignite burns with a long smoky flame. The calorific power is variable, being for C as enumerated above, 5000; and 5700, 6500, and 7000 calories in samples carrying little ash and so dried as to contain but a low percentage of moisture.

Locality.	Character of Coal.	Moisture.	Fixed Carbon.	Volatile Constit.	Ash.	S.	Calorific Power.
	A—Wood	20.00	40.00	1.60	3100
	B—Peat	24.20	45.30	27.00	3.30	0.20
Gallup, N. M.	C—Lignite.....	12.14	47.63	32.81	7.42
Hams Fork, Wyo.	D—Lignite	7.75	50.60	35.10	6.55
Pittsburg, Pa.	E—Bituminous	3.00	48.50	38.25	7.50	2.75	7110
Connellsville, Pa.	F—Bituminous	2.90	52.00	33.60	8.20	1.60	7333
El Moro, Colo.	G—Bituminous.....	0.95	56.41	29.82	12.82	0.41
Pocahontas, W.V.	H—Bituminous.....	0.69	73.02	19.96	5.67	0.66
Bennington, Pa.	I—Semi-bitum'ous	1.73	67.03	23.89	6.69	0.66
Colorado	J—Semi-anthracite	2.27	78.83	8.83	9.39	0.68
Pennsylvania	K—Anthracite.....	2.98	87.13	3.38	5.86	0.65
Rhode Island.....	L—Anthracite	1.18	85.70	3.80	8.52	0.80
	M—Graphite	99.40	1.00

Fig. 6. TABLE OF NATURAL SOLID FUELS.

The table (Fig. 6), gives the proximate analysis of a variety of fuels, the calorific value of some of these, and also the sulphur contained. The latter element is of importance in smelting iron ores,

since it must be eliminated from the iron which it would render brittle.

Bituminous coals.—These are distinguished from lignites by their deep-black streak, greater density, and lamellar structure. They contain but little water when first mined. We may distinguish the following different kinds:

(1) **Non-coking coal with a long flame.**—These coals closely approach lignites, furnish 55 to 60% pulverulent coke, and give a long smoky flame. The average composition of the dry coal is:

	Per cent.
Fixed carbon	54
Volatile constituent	42
Ash	4
Water	4

The calorific power varies from 8000 to 8500 calories.

(2) **Coking long-flame gas-coal.**—These coals give 60 to 68% friable, porous coke. They contain, when air-dried:

	Per cent.
Fixed carbon	63
Volatile constituent	31
Ash	6
Water	6

The calorific power varies from 8500 to 8800 calories.

(3) **Furnace coal.**—These coals are black, and never hard. They burn with a long smoky flame, softening the while, and swelling in the fire. They yield 68 to 74% of a swollen coke, and when quite dry are shown by analysis to contain:

	Per cent.
Fixed carbon	69.0
Volatile constituent	26.5
Ash	4.5

The calorific power of the dry coal varies from 8800 to 9300 calories.

(4) **Coking coal with a short flame (semi-bituminous coal).**—These yield 74 to 82% of a compact coke and contain, when dry:

	Per cent.
Fixed carbon	73
Volatile constituent	20
Ash	7

The calorific power varies from 9000 to 9600 calories.

Anthracite coal.—(1) **Semi-anthracite.**—These coals burn with a

short flame and yield 82 to 92% of a pulverulent (sometimes fritted) coke. They are products of transition to true anthracite. Their composition on a dry basis may be stated as:

	Per cent.
Fixed carbon	83
Volatile constituent	11
Ash	6

The calorific power varies from 9200 to 9500 calories. The percentage of ash ranges from 1 sometimes to 30, but seldom exceeds 7.

(2) **Anthracite proper.**—This is the final product in the transformation of vegetable matter into coal. It is of a jet-black color, of a vitreous lustre, homogeneous structure, and conchoidal fracture. When water-free its composition is:

	Per cent.
Fixed carbon	89
Volatile constituent	4
Ash	6

Anthracite burns almost without flame. The carbonaceous residue after distillation shows no sign of coking. In conjunction with coke for use in the blast-furnace for making pig-iron, Pennsylvania anthracite is used.

Coals of very different properties may appear alike if represented only by proximate analyses. The comparative calorific value may be judged of by Berthier's method. This consists practically in the operations of a lead assay, using an excess of litharge, with a gram of the fuel, and noting the size of lead button reduced. One can also judge a good deal about the character of the coal by coking it in a covered crucible and weighing the coke produced, judging the character by the appearance of the product. The proximate analyses (Fig. 6), showing the different kinds of coal, determine to which class any given kind belongs.

Graphite.—This is of interest, not as a fuel, but as a refractory material, particularly when combined with clay. The analysis given in the table is that of a pure form of graphite. Ceylon graphite contains 79.4% carbon and 15.5% ash and some volatile matter.

Petroleum or fuel oil.—This is the most concentrated of fuels, and, when the cost justifies, can be used not only for generating steam, but for roasting and melting. It will be found, in burning fuel-oil from various localities, that the calorific power is much the same for the different kinds. Beaumont (Texas) oil has a calorific power of 10,820 calories, and a specific gravity of 0.88 (7½ lb. per

gallon). Oil can be burned in such a way as to give, not only a high and uniform temperature, but also the oxidizing (roasting), or reducing action that may be desired. The air for combustion is best pre-heated as well as the oil, and it will be found advantageous to inject the oil under a high steam-pressure. A mixture of light and heavy oils should not be used. In Russia where oil has been employed in open-hearth steel-furnaces of 10 to 15 tons capacity, oil to the extent of 15 to 20% of the weight of the charge has been used. As regards comparative costs at the Selby Smelting & Lead Works, Vallejo Junction, California, it was found that the saving by using oil was 40 to 60% with oil at \$1.71 per bbl. (42 gal.), and coal at \$6 per ton. A suitable control of the grade of the matte was possible by the regulation of the flame.

Natural gas.—In Ohio, Indiana, and Kansas, particularly, there are districts where natural gas has been obtained by boring for it, as for oil. It is the most efficient of natural fuels, having a calorific power of 611 cal. per cu. ft., or 27,861 cal. per pound. The following analysis will give an idea of the composition of Pennsylvania natural gas. It shows that natural gas is composed chiefly of marsh-gas and hydrogen:

	Per cent, by volume.
Carbon-dioxide (CO ₂)	0.8
Carbon-monoxide (CO)	1.0
Oxygen (O ₂)	1.1
Ethylene (C ₂ H ₄)	1.0
Ethane (C ₂ H ₆)	3.6
Methane (marsh-gas) (CH ₄)	72.2
Hydrogen (H ₂)	20.7

Charcoal.—Wood, packed in a kiln, and permitted to partly burn, changes by distillation of the volatile portion by the heat produced from the portion burned into charcoal. The charcoal retains the form of the wood from which it was made, but has a specific gravity of only 0.2. It is of a dull-black color, soils the fingers but slightly if of good quality, but much if poor. It should ring when struck, and should show the annual rings of the wood distinctly. The density of charcoal varies with that of the wood from which it was made, dense woods giving a dense charcoal. A heaped bushel (1.5555 cu. ft.) weighs 14 to 16 lb. When apparently quite dry, charcoal still contains 10% or more of moisture. Dry charcoal contains 95% carbon, 1.5% ash, and has a calorific power of 7610 pound-cal-

ries per pound. Charcoal is used in iron blast-furnaces particularly in localities where wood is abundant; and it produces a pure, strong iron, free from sulphur, called 'charcoal-iron'. Charcoal has been used also for silver-lead and copper smelting in districts difficult of access. In these cases it has done especially well when coke could be secured to use in conjunction with it. It is, however, a friable fuel, making fine dust sometimes to the extent of 10%; and this 'fine' is apt to make trouble in the blast-furnace. If under-burned, it is heavier and more dense, and has a brown color. Portions of the wood found imperfectly burned are called 'brands' and are returned for the next burning.

Charcoal is generally made in a kiln. One of these is shown in section in Fig 7, showing method of filling. The kiln is set at the foot of a steep bank so that it can be charged conveniently from

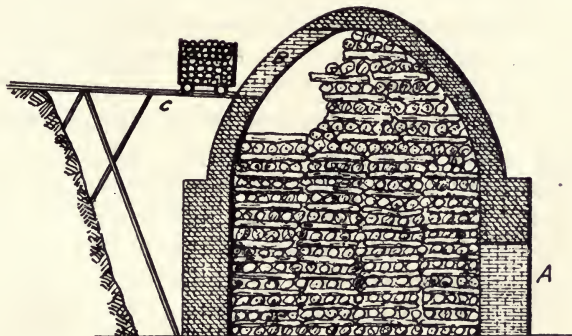

Fig. 7. SECTION OF CHARCOAL KILN.

above. It has two charge-doors *A* and *B*. The first of the wood is conveyed through the lower door, and placed. The remainder is brought along the run-way *c*, and introduced through the upper door *B*. There are three rows of openings, 3 by 4 in. in size, spaced 2 ft. apart, around the bottom of the kiln. The kiln is lighted at the lower door, and when fairly started, both openings *A* and *B* are closed with sheet-iron doors. These are tightly luted with clay, and the air is thus caused to enter by the small holes. When combustion has progressed sufficiently, these openings are tightly closed, and the kiln is permitted to cool slowly. The period of charring or burning is eight days, and the cooling four days additional. Such a kiln holds 25 cords of wood and produces 1125 bushels of charcoal weighing 16 lb. per bushel, or about 20% of the weight of wood charged.

By-product charcoal.—An example of the modern method of

making by-product charcoal for iron blast-furnace use is one at the Pioneer Iron furnace, Marquette, Michigan. Here there are 86 kilns each holding 80 cords. The daily requirement is 20 carloads, of 16 cords each, amounting to 320 cords. The kiln is packed full of wood, the sheet-iron doors put on and closed, and fire is started at a man-hole in the apex of the dome. As soon as combustion gains sufficient headway, this opening is closed, and smoke escapes by way of a flue leading from the base of the kiln to the chimney, continuing thus until most of the aqueous vapor has escaped. At this stage the chimney is closed, and the vapors pass by a smoke-main to the condensers, the current being aided by an electrically driven fan. The cold surface of the copper tubes of this condenser precipitates the condensible portion of the gas, while the gas itself goes on to the boilers, where it is burned for steam-making. The condensible portion, amounting to 41% of the weight of the wood, is called green liquor or pyroligneous acid, and consists mostly of water, but contains also alcohol, tar, ammonia compounds, acetone, and acetic acid. The tar is separated in settling tanks, and the liquor passes to the primary still-house. Copper stills here remove the vapors of alcohol, acetic acid, and much water from the liquor. The neutralizing tank receives the product, and into this is mechanically stirred milk-of-lime to neutralize the acid by the formation of acetate of lime. The neutralized liquor is allowed to settle, and the supernatant solution is drawn off and conveyed to the refining-still house. By fractional distillation a crude wood alcohol is obtained here, and a solution of acetate of lime is left behind and recovered by evaporating the solution. The crude alcohol is then purified by further distillation until a clear 95% wood-alcohol is obtained. A cord of wood (4500 lb.), yields 880 lb., or 19.5% dense charcoal of 20 lb. per bushel, 208 gal. of pyroligneous acid, 8 gal. of wood-tar, 64 lb. gray acetate of lime, and 4 gal. wood alcohol. By the sale of the wood-alcohol, acetate of lime and formaldehyde, and by the superior quality and consequently higher price of charcoal-iron, it has been possible to build up this industry, where the supply of wood is abundant, in spite of the serious competition of iron smelted in blast-furnaces using coke.

Coke.—This is made from coal in kilns, in a way similar to that of making charcoal. Bituminous coal which cokes or fuses at the high temperature of the kiln or oven is used for this purpose.

The raw screenings, in the example below, contained much fine passing a 1½-in. bar-screen. From this, the residue left after removing the lump of merchantable coal, coke was made. By washing the fixed carbon was increased and the ash in the coke reduced to

14.24%. A part of the sulphur also was removed thereby. The refuse was high in ash, and low in fixed carbon, as was to be expected; but the yield of washed coal was 85% of the raw screenings, and the coke 70% of the washed coal. When the coal contains slate, 'bone', or pyrite, it is often improved by this process of washing, or separating the waste-matter by concentrating. An example of a semi-bituminous southwestern coal is shown below:

	Moisture.	Volatile combustible matter.	Fixed carbon.	Ash.	Sulphur.
Raw screenings	1.40	19.79	60.25	17.33	0.85
Washed coal	0.79	19.10	69.35	10.24	0.52
Coke	0.43	1.39	83.47	14.24	0.82
Refuse or waste	2.22	15.76	30.96	50.12	0.93

A beehive-oven, Fig. 8 (B), is charged through a hole in the roof. Each oven holds 5 to 6 short tons of coal. The charge in making 72-

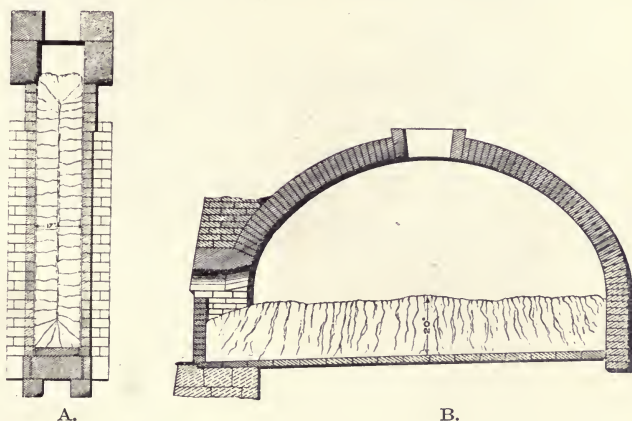

Fig. 8. SECTIONS OF BY-PRODUCT (A) AND BEEHIVE (B) COKE OVENS.

hour coke is dropped in the morning into the hot oven from a coal larry or car above, and is leveled through the side door, filling the oven to the depth of 26 in. The door is then walled up with dry brick and plastered over, but an opening is left near the top, as shown in section, for the admission of air. Combustion soon begins, and a dark smoke escapes at the top opening. After four hours this becomes dense and white, and the gases ignite or strike, and flames issue from the top. For twelve hours the oven burns with a dull, smoky flame above the surface of the charge. The flame becomes bright by the second day and then the air-supply is partly cut off. On the third day still less air is admitted, and at the end of this day

no more flames appear and the whole interior of the oven is red-hot. The air-openings are now luted, and the charge is left in this condition until the morning of the fourth day when the coke is drawn. The actual coking is complete in 55 hours and the whole operation, from one charging to the next, in 72 hours. To draw the coke the temporary brick wall of the door is taken down, and water from a hose played into the oven. After being thus cooled on the surface, the coke is pulled out with a long-handled coke-drag or hook, and further cooled with water while being withdrawn.

The process of fusing and coking begins at the top, and extends downward through the mass of coal to the bottom of the oven, and the coke, when well burned, takes the form of prismatic masses with hard side-surfaces of a silvery steel-gray color, and top ends soft and nearly black. The silvery appearance is due to deposited carbon, which has the desirable quality of protecting the coke against the action of the furnace-gases. The black ends of the contrary are readily attacked. A good coke has a well-developed cell structure which permits the penetration of the hot ascending gases in the blast-furnace. This so raises the temperature of the coke that the air, at the bottom of a furnace striking it, produces vigorous and rapid combustion. Other qualities are purity, uniform quality, and sufficient coherence for handling. Purity depends upon a low ash, 10% being good, and 6 or 8 exceptionally pure. Coke intended for iron blast-furnace work, should not contain more than 1% sulphur and commonly less than 0.5 to 0.8% of this element. For lead or copper blast-furnaces high sulphur does not greatly matter. 'Uniform quality' means but a small amount of 'black ends'. These as stated, burn in the upper part of the iron blast-furnace by the action of carbon-monoxide gas. 'Coherence in handling' as is evident, is important where coke must be transported far, and re-handled at the smelting works. Fines tend to 'slow down' a furnace, but can be rejected by the use of a coke-fork. The calorific value of Pittsburg coke, containing 89% fixed-carbon, 10% ash, and 1% sulphur, is 7272 lb. cal. per pound.

8. BY-PRODUCT COKE-OVENS OR RETORTS.

The advantage of the by-product coke-oven is, that by the constant, high, and quick heat, it can coke a coal that contains but little fusible matter. Besides this the by-products can be saved and the total yield of valuable products thereby increased. Two types of ovens of this kind extensively used in the United States are the Otto-

Hoffman and the Semet-Solvay. The general arrangement of an Otto-Hoffman plant is shown in Fig. 9. Coal is brought in over two tracks, shown at the left, and discharged into feed-hoppers. It is drawn from these as required, and conveyed to two sets of rolls, one for coarse, the other for fine crushing, and reduced to a size of 4 to 10-mesh. The crushed coal is raised by an inclined elevator, and dis-

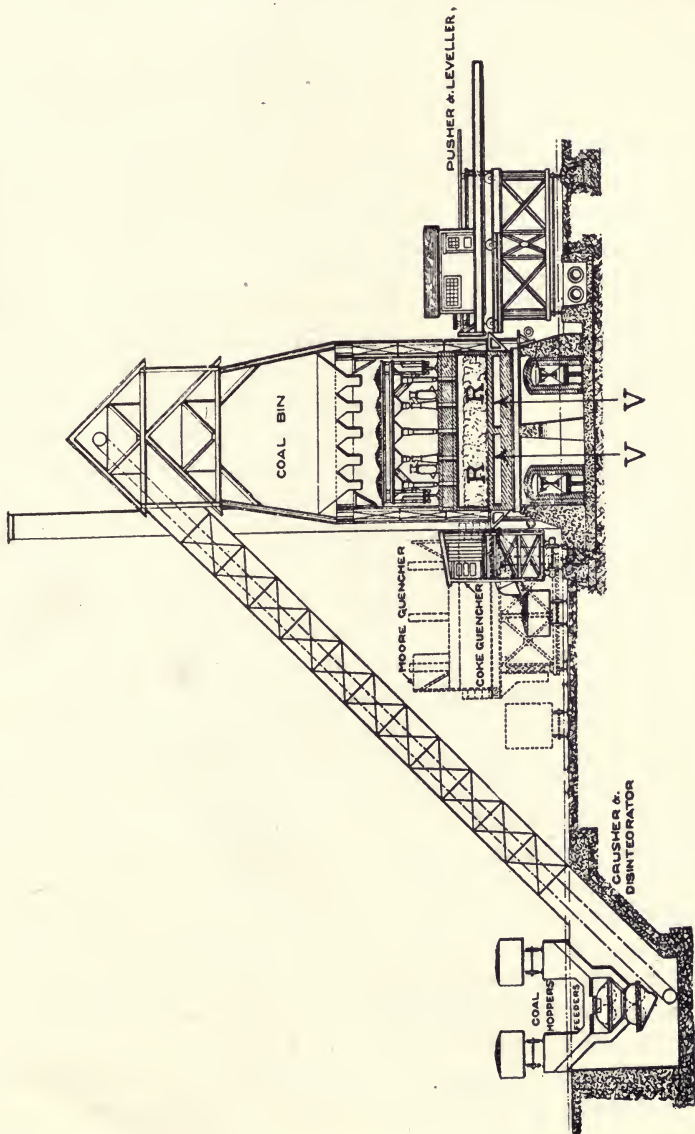

FIG. 9. SECTIONAL ELEVATION OF OTTO-HOFFMAN BY-PRODUCT COKE-OVEN PLANT.

charged into the main storage coal-bin. This bin has a hopper-shaped bottom with several discharge spouts, delivering to an 8-ton larry which runs along on top of the ovens or retorts, *R,R*, of which there may be 20 to 60, placed side by side, in one block of masonry. Each retort or coking chamber is 17 in. wide, 43 ft. 6 in. long, and 6 ft. 6 in. high, and is closed at each end by an air-tight cast-iron door. In Fig. 8 (A) is shown a transverse section of such a chamber, indicating the interesting lines of fractures and columnar structure of the coke.

Turning again to the general view, Fig. 9, the larry is seen above the retorts. It is worked by an electric motor and consists of 5 hoppers supported by a frame upon a traveling carriage. From each hopper pipes extend downward to the feed-openings in the top of the chamber. The doors of the chamber being closed, and the chamber itself hot from previous operation, a charge of 8 tons of coal is dropped in, and leveled by means of a bar inserted through an opening near the top of the door. Distillation at once begins, and the gases are conducted to condensing-chambers to free them from certain by-products, such as tar, ammonia, and benzol. The first portion of the gas is highest in illuminating power, say 24 candle-power, but later drops to 16 candle-power. The first is, therefore, sent to the city-mains for use as illuminating gas, the latter reserved to heat the chambers by combustion in flues which encircle them. The side-walls are constructed to provide these flues for heating the oven, and maintaining the activity of the distillation. The products of combustion, before entering the stack, go through a regenerating chamber containing a checker-work of tile, while air is pre-heated for combustion in a similar chamber at the other side. Thus the gas is burned with highly heated air, and produces an intense heat in the walls of the coking-chambers. The reversing valves are now changed, and the currents of air and gas caused to move in the opposite direction. The direction is thus repeatedly alternated, as is customary in open-hearth work. At the end of 24 hours, when coking is complete, the end doors are opened and the coke is pushed out by means of a ram shown at the right. The coke is received in a coke-quencher, shown at the left of the oven, and is here cooled with water and afterward discharged into a car beneath. The total yield of coke is 72%, or 6% more, for the same coal, than that of a beehive oven. The coke is hard, dense, and as reliable as beehive coke made from the same coal, but has not the silvery gloss of the latter.

Costs.—The actual cost of making coke may be stated as 50c. per ton in the beehive process and 37c. in by-product ovens. To this

must be added the cost of the $1\frac{1}{2}$ tons of coal required. A beehive plant operated 6 days per week and of 400-ton daily capacity would cost \$60,000. A by-product plant of the same capacity would cost \$300,000. Allowing for interest and depreciation, the cost is found to be much the same for either process.

9. FUEL OR PRODUCER-GAS.

Of the various kinds of producers used for making artificial fuel-gas we shall consider two, 'the simple producer' and the 'mixed-gas producer'.

The simple producer.—These use ordinary or inferior fuels, such as wood, wood-refuse, bark, sawdust, or peat, but generally soft or hard coal. We have shown in Fig. 2 and 3, in the sections of furnaces containing fuel, how gas is produced where air rises through a deep coke fire and where fuel is thus in excess. The necessary air may be supplied by a natural draft or by a fan. The fuel, descending in the producer, first is dried by the hot, rising gases, then further heated until the volatile matter is distilled, and finally, as it reaches the lowest zone, is oxidized or burned by the entering air. The residue is the ash of the fuel, which is either ground out at the bottom, as in the Taylor producer, Fig. 10, or discharged through the grate while containing still some carbon which is lost. The escaping gases issue at a temperature of 300° to 1000° C., and thus carry away heat.

An analysis of producer gas made from soft coal gave the following analysis by volume:

	Per cent.
Carbon dioxide (CO ₂)	5.0
Carbon monoxide (CO)	23.0
Oxygen (O ₂)	0.5
Ethylene (C ₂ H ₄)	0.5
Methane (CH ₄)	3.0
Hydrogen (H ₂)	10.0
Nitrogen (N ₂)	58.0

Each pound of coal will give 60 cu. ft. of such gas, having a heating value of 82 cal. per cubic foot.

The mixed-gas producer.—This is the producer commonly used. In it a moderate amount of steam or water vapor passes with the air into the burning fuel, and there re-acts upon the carbon as follows:

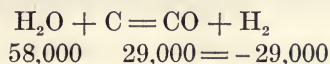

One volume of steam makes one volume of carbon monoxide and one of hydrogen. The water vapor may be obtained from the water-soaked ashes by evaporation in the lower part of the producer, or as

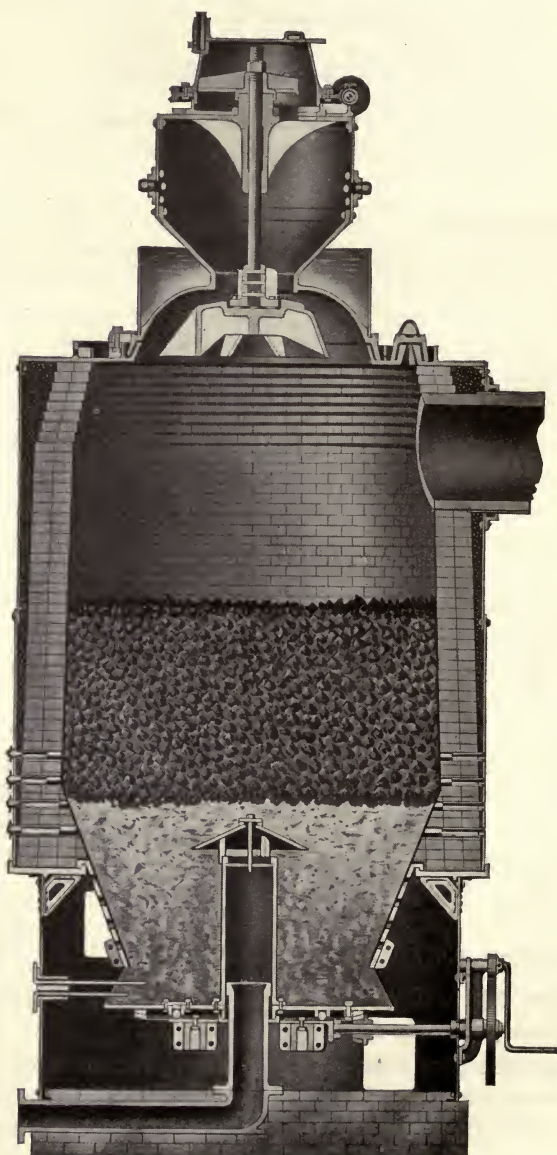

Fig. 10. TAYLOR REVOLVING BOTTOM GAS-PRODUCER.

in Fig. 10, may be injected under pressure into the fire. Steam also disintegrates the clinker and facilitates its removal.

(1) **The Taylor revolving-bottom producer.**—This consists of a steel, brick-lined shell, of 6 ft. diam. inside, and a cast-iron, boshed portion below, for ashes. The ashes are supported by a flat, circular, iron bottom, which once in about six hours is revolved by hand, to grind up and remove the ashes. The ashes fall from the edge of the disk to the floor of the ash-pit. Up through the layer of ashes a pipe is seen to extend, and by means of this, both air and steam are introduced into the fire. At the left is a steam injector that is not shown, by means of which additional air and steam are supplied to the fire, first by the horizontal pipe, then by the vertical one. Peep-holes at the side show the condition of the fire and the height of the accumulated ashes. The coal is charged into a hopper which is then closed air-tight. A slowly revolving vertical shaft provided with a distributor at its lower end, scatters the coal evenly over the fire. The producer-gas leaves by a large exit pipe near the top. Poke-holes in the cover are provided, and these are opened occasionally to stir the fire when tending to have spaces through which unconsumed air might pass. The composition of mixed-gas by volume, made in this way from bituminous coal is as follows:

	Per cent.
Carbon monoxide (CO)	24.5
Marsh-gas (CH ₄)	3.6
Ethylene (C ₂ H ₄)	3.2
Carbon dioxide (CO ₂)	3.7
Hydrogen (H ₂)	17.8
Oxygen (O ₂)	0.4
Nitrogen (N ₂) (by difference).....	46.8

(2) **The Loomis-Pettibone gas apparatus.**—Fig. 11 shows a complete plant of the Loomis-Pettibone system, with a positive gas exhauster, and intended both for producer and water-gas. Its operation is as follows: Hot fires are burning in both producers or generators, and the gas exhauster is in operation. Air is now drawn upward through generator 1, burning the fuel and making producer-gas. This generator may have just received fresh coal at *E*, and the coal-smoke, tarry matter, and producer-gas from it, are together drawn down through the hot fire in generator 2, being completely burned and fixed in so doing. The gas now goes through valve *B* to the boiler (valve *A* being closed), and the heat is there absorbed. It then passes from the top of the boiler through the pipe shown to

the bottom of the 'scrubber', a cylindrical tower of sheet-steel, in which it is caused to pass upward through pieces of coke resting upon perforated trays. The coke here is kept wet by means of a water-spray, and the gas is thereby cooled and cleaned. Rising to the top and to the wider part of the tower, the gas passes through a layer

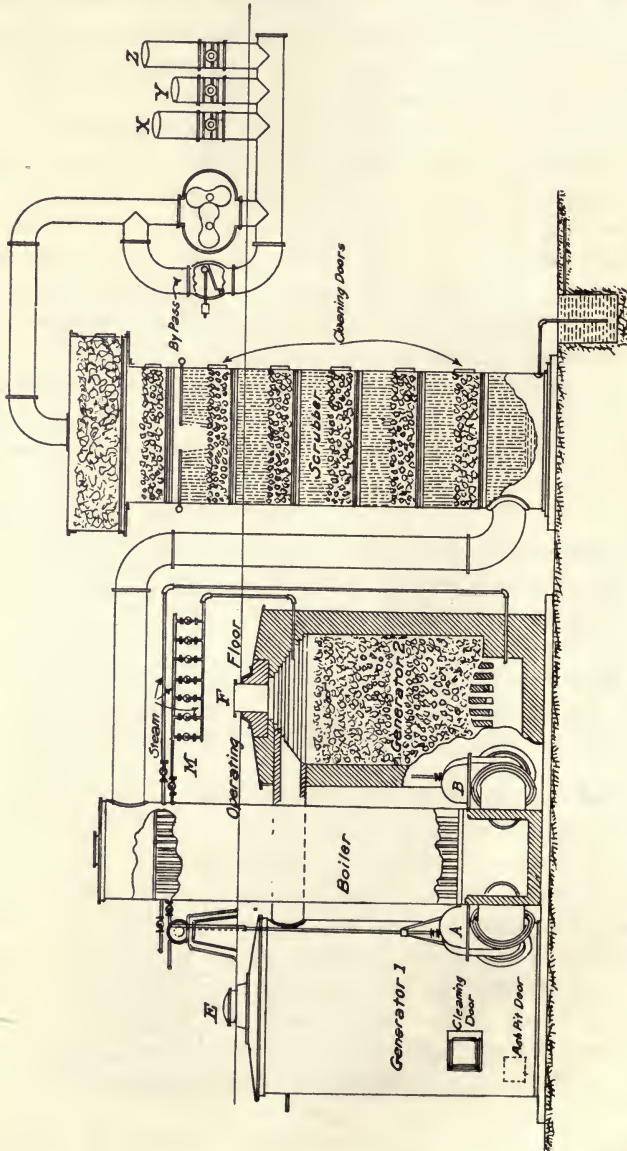

FIG. 11. LOOMIS-PETTIBONE GAS-MAKING PLANT

of fine shavings or 'excelsior', to remove any remaining dust. It then is drawn through the Root positive-blast exhauster *W*, and finally is driven through pipe *Z* to the gasometer for producer-gas, where it is stored for use. The fire in generator 1 having become clear and hot, generator 2 is charged afresh, and the ash-pit door opened. The gas current is then changed from generator 2 to generator 1, through valve *A* (valve *B* having been shut) to the boiler, thence through the scrubber and exhauster *W*, to the gasometer. The direction of the current is thus changed at intervals. For making water-gas, the ash-pit door is closed and steam from the boiler is injected beneath the grate of the generator while the fire is hot. The formation of the water-gas is completed, or the gas is 'fixed' by causing it to pass down through the other generator, it having been found that a part of the hydrogen reverts to steam without so doing. The making of water-gas cools the fire and after a few minutes the steam must be shut off and air again substituted. While water-gas is being made, it may go to the gasometer through the pipe *Z*, or, if desired, to permit it to go to the water-gas, holder *Z* may be closed and *Y* opened. When kept separate, water-gas is reserved for certain heating operations for which producer-gas, of lower calorific power, would be unsuited. The purge-pipe *X* is opened when starting, and by this means air in the system is expelled before gas is turned into the gasometer. Steam may also be admitted above the fire, and thus caused to pass down through the generator, and form water-gas. In fact, both air and steam may be introduced, either below or above the fires, to suit the best conditions of operating.

10. REFRACTORY MATERIALS.

General.—For the exterior of furnaces subject to the action of but little heat, common red brick, stone laid in lime-mortar or cement, or concrete is well suited; but for the lining of furnaces it is necessary to use refractory material to withstand the high temperature, and to resist the scouring and corroding action of the molten contents of the furnace. At a temperature below a red heat the combined moisture of lime-mortar would be expelled, and the mortar in consequence would crumble. At a dull red heat many stones crack, and flake off at the surface because of irregular expansion. Sandstone, however, is resistant to fire, and has been used for furnace-lining. Red bricks, laid in clay mortar, withstand a moderate red heat, but, at a temperature much above this, begin to soften or melt.

Refractories.—These substances are infusible at the high temperatures for which they are intended. Thus fire-bricks begin only to soften at 1500° to 1600°C., and silica-brick at 1600° to 1700°C. Refractories may be divided into the three following classes:

(1) **Acid (silica-brick, sand, and ganister).**—These are used to resist the scouring or corrosive action of acid slags. Being highly refractory they are more generally used for roofs or arches exposed to the highest temperatures. In such positions out of contact with the molten contents of furnaces they are not required to resist a serious fluxing action.

(2) **Neutral (graphite, chrome-iron, fire-clay, bone-ash, and carbon-brick).**—These materials well resist the action of neutral slags which are neither basic or acid. In the case of a basic open-hearth furnace, for example, it is customary to interpose a layer of neutral chrome-iron brick between the roof of silica-brick and the basic-lined hearth slightly above the level of the surface of the molten contents of the furnace where it would be unaffected by it. Were silica-brick used in contact with the basic lining, they would re-act upon the lining and melt.

(3) **Basic (dolomite, magnesite, etc.)**—These are used where the slag or matte is basic, as in the hearth of the basic open-hearth furnace. Basic slags quickly scour or corrode an acid, or even a neutral lining. It will be noticed that all the foregoing refractories not only have special resistant power but are infusible. This is particularly the case with carbon, either in the form of gas-carbon or charcoal.

We shall now discuss the acid refractories.

Sand.—This is used in repairing or fettling the interior borders or walls of reverberatory furnaces. It is made to form a steep bank extending above the level of the molten bath, to protect the wall from the corrosive action of the molten slag. Repairs are made after the charge has been withdrawn, when the interior sides of the furnace are exposed. The sand is thrown in by means of shovels, or placed by paddles or spoons provided with 16-ft. handles, to deposit the sand at the exact spot required. Sometimes a little clay-material is incorporated with the sand that it may be formed into balls. These are skilfully thrown across the furnace through a door to an eroded spot, or inserted by means of the paddle, mentioned above, and pressed into position with the bowl of a long-handled ladle. The bottoms of reverberatory furnaces are frequently made of sand in layers, and each layer fired successively, at the highest temperature of the furnace. The sand thus becomes fritted together, and hard-

ened into a coherent bed in this way, is built to the thickness of perhaps two feet.

Ganister.—This is used for furnace or converter-lining and is composed of a mixture of crushed silicious rock or quartz to which has been added about 15% clayey material to make it cohere. For lining converters, a silicious ore carrying gold and silver may be used instead of barren quartz rock. The material is rapidly eaten or scoured away by the action of the molten charge, and the precious metal contained enters the charge. This in reality results in a kind of ore-smelting, performed incidentally, and without additional cost.

Silica brick.—When quartz or sandstone, containing 98% silica,

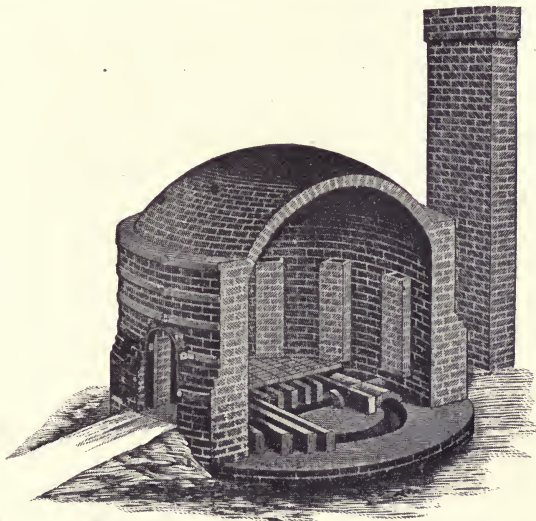

Fig. 12. BRICK KILN.

is moistened and mixed with a little lime paste made from quicklime, it coheres sufficiently to be molded into bricks. These are first dried in a steam-heated drying-room, then carefully placed in kilns in open order, and burned, at a temperature gradually increasing to a white heat. Fig. 12 represents a kiln of the down-draft type. It is a dome-shaped oven, 15 to 25 ft. diam., coal-fired by means of fireplaces set in the exterior wall. The flues within this wall are arranged as shown, so that the entering flame rises to the crown of the arch, and, passing downward through the brick, goes to the adjoining stack through flues in the floor of the kiln. Thus a high even temperature is obtained, and the bricks become sufficiently sintered

to stand handling and transportation, but are never as strong as the fire-clay brick.

Besides the lime-bond brick, above described, made by the addition of lime to silica, a clay-bond brick, less refractory, is made by the admixture of four parts of flint with one of clay. This makes a stronger brick than the lime-bond. The composition of each of these kinds of bricks is as follows:

	Lime-bond brick. Per cent.	Clay-bond brick. Per cent.
SiO ₂	93.48	86.32
Al ₂ O ₃	3.82	11.24
Total fluxing bases.....	2.62	2.50
	99.92	100.06

The clay-bond brick shows its greater fusibility in its alumina and silica ratio, as will be seen under the constitution of fire-bricks, and the proportion of alkali is higher than in the lime-bond brick, causing it to be much less refractory. Silica bricks withstand the highest temperatures, and expand when heated. To provide for this, expansion joints are arranged in the roof, side walls, and bridge of reverberatory furnaces, which close as the temperature rises. To slack off the tie-rods, also, is another way to accomplish the same purpose. Without this, furnace arches would bulge, and tie-rods would break. The linear expansion of these bricks when elevated in temperature to a white heat is 2.5 per cent.

We next shall consider the neutral refractories.

Graphite or plumbago.—Pure carbon in the absence of air is permanent and infusible at the highest temperatures. This is well exemplified in the carbon filament of an incandescent lamp. Even in the arc-light, the carbons, though gradually consumed, do not melt. In blast-furnaces, pulverous carbon accumulates, and forms scaffolds, and carbon-bricks, made of gas-carbon, have been used with some degree of success for the bosh-lining of iron blast-furnaces. Graphite is essentially carbon, but contains as impurities a little iron and a small quantity of gangue substance. An analysis of Canadian graphite gives 2% volatile matter, 20% ash, and 80% carbon. Such graphite is used for graphite or plumbago crucibles and retorts, when mixed with 45% air-dried clay and 5% sand. Graphite, in these mixtures is not only refractory, but prevents shrinking and cracking when the crucible or other object is dried after being formed.

Chromite or chrome-iron.—This is a double oxide of iron and chromium (FeOCr_2O_3) generally containing a little gangue. Chrome ore is made into bricks by crushing the ore, mixing with lime as in making silica-brick, and burning. These bricks should not contain more than 40% Cr_2O_3 . Chromite is not attacked by silicious slags, and resists high temperatures.

Fire clay, fire brick, and tile.—These refractories are the best known and the most used. The term fire-clay applies to kinds of clay capable of withstanding a high degree of heat. In good fire-clay the total percentage of fluxing impurities, such as ferric oxide, lime, magnesia, and the alkalis, is small (3.5% or less). In all fire-clay and water, some of the silica is combined chemically with the alumina. This forms a hydrous aluminum silicate, called kaolinite. Further silica present is in the form of quartz sand. Either kaolinite, or quartz alone, has a high fusion point (1850°C .), but in mixture, the fusion point is lower, and this reaches a minimum at 1670° when 10% kaolinite is present. By the continued addition of silica to kaolinite we therefore get a diminution of refractoriness until this exact proportion is reached, and after this, by continued addition of sand, an increase. The fire-clay, accordingly, is most refractory that contains the lowest percentage of fluxing base, and the least uncombined sand. A factor further affecting the refractoriness is the coarseness of grain. The New Jersey air-dried clays have the following composition and refractory qualities.

	(IV) Per cent.	(V) Per cent.
Kaolinite (clay base).....	57.47	98.95
Free silica	40.09	0.24
Total fluxing bases.....	2.53	0.99
	<hr/>	<hr/>
	100.09	100.18

	(IV) Per cent.	(V) Per cent.
SiO_2	67.26	45.76
Al_2O_3	23.36	39.05
H_2O (combined)	6.94	14.46
Bases (Fe_2O_3 , CaO , alkalis).....	2.53	0.99
	<hr/>	<hr/>
	100.09	100.26

Temperature of fusion..... 1670°C . 1810°C .

The clay base is computed as Al_2O_3 , 2SiO_2 with combined water,

The silica not present in this combined form is regarded as 'free'. It is seen that the less refractory clay (IV) contains more fluxing base, more silica and less alumina than (V) to account for its fusibility.

Fire-clays are used not only for fire-bricks and tiles, but also for muffles, retorts, and clay vessels of different sorts. The clay varies much in plasticity. Clay alone is unsuited for bricks, since in burning it shrinks and cracks. Fire-brick manufacturers, therefore, employ a mixture of several grades of clay, adding also a certain percentage of coarsely ground fire-brick or quartz. The addition of this unshrinking material prevents the cracking that otherwise would result. The assayer, who uses clay for luting, mixes with it for the same reason at least half its weight of sand. In the manufacture of fire-bricks the required mixture is ground in a dry-pan, a machine similar in construction to the Chilean mill (See Fig. 145), but pro-

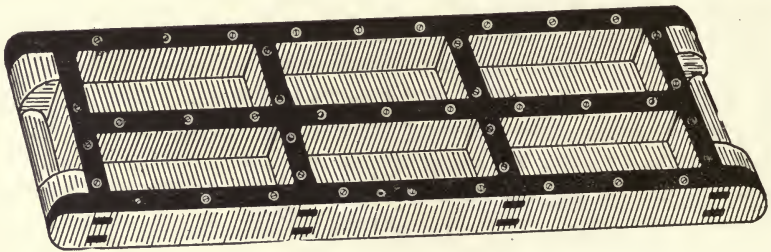

Fig. 13. BRICK MOLD.

vided with a grated bottom made of perforated plates to discharge the material through these openings when ground sufficiently fine. Scrapers are placed in front of the rollers to throw material in their path, and the mixture when ground is screened, and further mixed in a horizontal plug-mill, being there tempered by the addition of water to the desired consistence. (See Fig. 164.)

The molding of bricks is done by hand or by machine. If by hand the mixture is brought to the consistence of a mud, and made into balls sufficiently large to fill a six-brick mold. (See Fig. 13.) The mold is first sanded to prevent the adhesive mud from sticking. It is thrown into the mold with force, to completely fill it, and the excess is cut off with a stick or wire, and the bricks dumped on a pallet or board. The pallets are placed upon racks, and air-dried until so stiff as to indent but slightly under pressure of the finger. They are then put through a re-pressing machine (Fig. 14), where they are given their exact form. When re-pressed, they are again placed on

pallets and run into a dryer which is divided into chambers and heated by steam so that the last of the moisture is removed. The bricks, now so coherent that they can be handled with little damage, are piled in open order in the kiln, already described (See Fig. 12), and are burned at a temperature between 1230 and 1390°C., requiring two or three weeks for this.

In machine molding, called the 'stiff-mud process', the clay is tempered with less water, and is much stiffer when molded than in hand-molding. The general form of the stiff-mud machine, known as the auger machine, is that of a horizontal cylinder, closed at one end, and tapering to a rectangular outlet at the other, the size of the brick. Within the cylinder is a shaft carrying blades similar to those

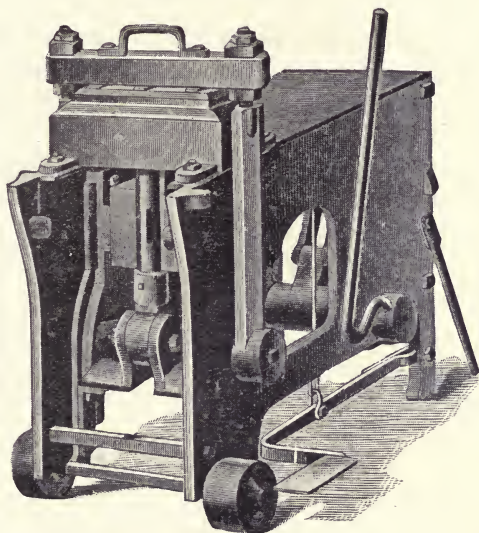

Fig. 14. RE-PRESSING MACHINE.

in a pug-mill, but at the end nearest the die, or outlet, the blades are replaced by a tapering screw. The tempered clay is fed into the cylinder at the end farthest from the die. It is mixed, and moved forward by the blades until seized by the screw which pushes it through the die. The bar of clay issuing from the machine is received upon a cutting-table and cut into bricks by means of a wire frame. The further treatment of these bricks, with the drying, re-pressing, and burning, is like that of hand-molded bricks.

To resist abrasion, fire-bricks must be hard; to resist corrosion or slagging, dense; and to resist high temperature and sudden

changes of temperature, porous and coarse in texture. We accordingly use the hard bricks for door-openings, dense ones for reverberatory furnace walls, and the porous and coarse ones for the roofs. The refractoriness of a fire-brick depends on the quantity of the fluxing bases (especially alkalis) and silica contained, and on the coarseness of the grain.

Bone ash.—This is made by burning bones in a kiln with an excess of air, and grinding the white residue to 20-mesh size. Organic matter is thus removed and an impure calcium phosphate obtained. Though a neutral material, this resists the action of litharge, and it is accordingly used, not only in assaying, but in making the 'tests' or movable hearths of the English cupelling-furnace shown in Fig. 178.

Carbon brick.—Gas carbon, such as is used for arc lights, is made into brick with a limited amount of gas-tar and burned in a kiln. This brick has been found to be particularly resistant and refractory in a reducing atmosphere, as at the bosh of an iron-furnace.

Dolomite.—The alkaline-earths, lime and magnesia, are strong bases and are resistant to basic slags, but are readily fluxed by the silica of silicious slags. Quick-lime is infusible, but is easily affected by the moisture of the air, and insufficiently coherent to be used for making basic brick. Dolomite is magnesian limestone, and is a cheap refractory material. It is prepared for use by burning, much as is limestone. The proportion of lime to magnesia varies in dolomite, but the more magnesia the better for use as a refractory. The composition of a typical sample is as follows:

	Per cent.
CaO	31.62
MgO	20.19
SiO ₂	1.70
FeO	1.22
CO ₂	45.35
	100.08

Magnesite.—This is the most valuable of the basic materials. When magnesium carbonate is calcined at a high temperature it loses the carbon dioxide and the residue is practically infusible. Magnesite is usually colored dark-brown by the presence of about 4% iron oxide. ~~It agglomerates but little, and at a high temperature does not combine with a silica lining if in contact with it in a furnace wall.~~ It is used both for basic-lined converters and for basic open-

magnesite containing 7 to 8% Fe is preferred

hearth furnaces where the slag contains as little as 15% silica. It is used also as a lining for forehearth in copper matting where it would be in contact with low-grade corrosive matte. The nature of the mineral is shown by the following analysis:

	Per cent.
CaO	1.68
MgO	42.43
SiO ₂	0.92
Fe ₂ O ₃ and Al ₂ O ₃	4.30
CO ₂ and H ₂ O.....	50.41
	99.74

Other refractory materials.—A mixture of portland cement 2 parts, clay 1 part, and ‘chamotte’ or coarsely-ground brick 7 parts, moistened and molded into bricks or blocks, or used for patching furnaces, sets quickly and withstands a white heat without disintegrating. It is easily made and especially useful for rapid repairs. Only as much is mixed as is to be used at once.

While common red bricks are not refractory, the least fusible can be used in that part of the roof of a reverberatory furnace where the temperature is not high or only at a red heat. Such bricks are used for backing fire-brick structures. As a general rule each kind of brick should be laid in a material similar to that of which it is composed. We should expect slagging to take place, for example, at joints made of loam-mortar in fire-brick. Such loam, while cheap, is inferior to fire-clay. An analysis of good loam gives:

	Per cent.
SiO ₂	80.99
Al ₂ O ₃	9.65
Total impurities.....	4.91
Ignition loss	4.43
	99.98

Here we note that the fluxing bases rise to nearly 5%, while alumina approaches 10%, the ratio of the most fusible compound of alumina and silica. Where the fluxing bases rise above 5%, there is risk of complete melting at high temperatures.

11. SAMPLING.

The principles and object of sampling.—Sampling consists in obtaining from a large quantity of ore a small portion for assay. This

must correctly represent the entire quantity of the ore, whether it be a few hundred pounds or thousands of tons, a wagon-load, or a ship-load. Often we have a lot of ore, in which rich pieces mingle with poorer ones, or even with waste. In sampling we must take this variation into account and represent each part, not only according to its value, but also to its quantity. Often ore is bought or sold upon the results of sampling. Thousands of dollars are involved and cash is paid for ore before the purchaser has treated it. In other cases ores taken by the reduction works are treated separately, the owner receiving whatever is obtained, a charge being made to cover the cost of treatment and the profit to the reduction works. In this latter case sampling could be omitted. Similarly at a mill and mine, operated in one interest, the sampling may be omitted when considered an unnecessary expense. Efficiency of the work is then determined by the assay of the tailing.

If a reduction-works is producing lead, copper, or zinc, in a form ready for market, the metals do not necessarily require to be sampled. Whenever the precious metals are also present in such quantity as to pay to separate them, however, the metal is sampled to learn the values contained before selling to the refining-works that is to effect the separation. In blast-furnace treatment, ore and all other constituents of the charge are sampled, assayed, and analyzed. From the data thus obtained, the charge can be correctly calculated and proportioned.

Not only is it necessary to ascertain the value of ores and of metals that result from metallurgical operations, but as well the value of the portions rejected. The efficiency of the work of the metallurgist depends upon thorough extraction from the parts thrown away. To be assured of this, samples of slag or tailing are taken at frequent intervals. In finding the value of a lot of ore, we first weigh the ore, and base the assay-value upon the dry weight. To do this we must determine the percentage of moisture contained, as shown by a 'moisture sample'. We then sample the ore regularly, and finally assay the regular sample. Thus, suppose we have a lot of ore weighing 10,800 lb., containing 7% moisture and by assay 54% lead worth 3c. per pound. Since the assay is made on the dry weight, we have, after deducting moisture, 10,044 lb. ore containing 5424 lb. lead worth, at 3c. per pound, \$162.72.

12. ACTUAL SAMPLING OF ORE.

Receiving and weighing.—At reduction works that purchase ores (custom works), the ore arrives either loose, or in sacks. Whether

received by wagon or by car, the vehicle and ore are weighed together on platform scales, thus finding the 'gross weight'. When the vehicle is emptied, the weight, called the 'tare', is similarly taken. The difference is the 'net weight' or the 'wet weight', and this is recorded. When ore arrives in sacks, the weight of the sacks also is deducted. Often sacked ore may be removed to scales to be weighed, and only the weight of the sacks deducted, the difference being the net or wet weight. Sacks, if of sufficient value, are dried and returned to the owner. Railroads often return them without extra charge. Sometimes the sacked ore, if pulverulent, rich, or frozen, may be charged, sack and all, into the blast-furnace, the sack serving to retain the fine contents until smelted, thus preventing the loss of flue-dust.

The moisture sample.—In the theory the moisture sample should be taken at the instant of weighing, since the ore may dry and become lighter. The sample is taken while the car is being unloaded or immediately afterward. To represent by the sample the ore as contained in the car, holes are dug at average points (setting aside the dry top layer) and small portions are taken of ore that appears to be of average moisture. These portions are put in a covered can, and 50 oz. of the mixture are weighed on a moisture-scale. After cautiously drying on a hot-plate, or preferably over night on steam-coils, the 50-oz. portion is again weighed, and the percentage of moisture determined by the loss in weight. The shipper often sends a representative to witness the sampling of his ore. Such a man should pay attention to this detail, otherwise too high a percentage may be deducted for moisture.

Sampling methods may be divided into two class: hand-sampling and machine or automatic-sampling. Any method of sampling includes the starting and finishing operations.

Hand-sampling.—This includes the methods called 'grab sampling' and 'trench sampling', which are imperfect, and the regular methods known as 'coning and quartering', 'fractional selection', and sampling with the 'split shovel'.

The grab sample.—This imperfect method consists in taking at uniform distances over the pile, proportional amounts, broken from the lumps and taken from the fine. These portions are mixed, then reduced in size by a method of hand-sampling, later to be described. The imperfectness of the method is due to the fact that only the upper part of the pile is represented in the sample. The method is used only as a quick and inexpensive means of obtaining an approximate idea of the value or composition.

The trench sample.—This is taken from ore in a pile, or at a dump, where an approximate idea of the whole is desired. A trench is dug transversely through the pile, selecting some place for this that is fairly representative of the whole. As the workman advances with the cut he throws the larger part or 'rejected portion' aside, but reserves an aliquot portion. Thus each tenth, twentieth, or hundredth shovelful is reserved for sample, to be further reduced in size in the usual manner. The lower part of the pile by this means is represented. In place of digging a trench, another method consists in digging trial pits at regular intervals over the pile or dump and reserving an aliquot portion of the excavated material. The small reserved portion of the whole is then subjected to regular sampling methods. The trench-method and the trial-pit method are imperfect, since they represent only a part of the pile.

The regular or complete methods of hand-sampling, including coning and quartering, fractional selection, and the split-shovel method, are used where an accurate sample that could be used with confidence in buying or selling is desired. Of these methods coning and quartering is the oldest.

Coning and quartering.—Before applying this method, and to save unnecessary labor, it is usual to take an aliquot portion of the ore, say every tenth shovelful, as the car or wagon is being unloaded. The sample from a 100-ton lot would then be 10 tons. It is wheeled to a crusher, crushed roughly to $1\frac{1}{2}$ -in. size, and as it falls from the crusher, wheeled to a place on the sampling floor and dumped in the form of a circle or ring, leaving a space of 10 ft. diam. inside. The workmen circle around this ring, shoveling the ore to the apex of a cone which they build at the center. Care is taken that each shovelful is thrown upon the apex of this cone. The ore is then drawn down with shovels, to the form of a flat disk 8 to 12 in. deep. This is marked by diametrical lines into four equal sections (hence the word quartering) of which two are left on the floor and two wheeled away. The reserved sectors are shoveled again into a ring and made into a cone thus half the size of the first. This is again flattened down, quartered, and two opposite quarters reserved. The process goes on in this way, by coning and quartering the ore, as long as any single rich piece can not appreciably raise the value of the sample if retained, or lower it if rejected. At this point the ore is crushed to half-inch size by means of rolls. Coning and quartering is resumed until it becomes necessary to crush again, this time, say, to wheat size. The ore is then worked down to a sample two pounds in weight, and this quantity is ground to pass through an 80-mesh screen. It is

thoroughly mixed by 'rolling' on a sheet of thin rubber cloth; and the mixed product is placed in 4-oz. bottles or manila sample-sacks. These are sealed and marked with name and particulars of the lot of ore.

Fractional selection.—This differs from the quartering method in that every second or fourth shovelful is reserved for a sample after coarse crushing, but the selected portion is coned for the purpose of mixing. From the cone each second or fourth shovelful is again reserved and coned, and this is continued until it becomes necessary to re-crush. After this, the reduction proceeds in the same way except that a smaller shovel is used toward the end, to accord in capacity with the size of the sample.

The split-shovel.—By this method a shovel, resembling a fork, is used, the tines of which consist of troughs, each 12 in. long and 2 in. wide. The space between the parallel troughs is 2 in. wide. Operating on ore crushed to half-inch diameter, one half of the ore shoveled upon the sampler drops through the spaces, and half is set aside as a sample. The sample is again divided by the split-shovel, reducing the size again one-half, and so on until, as in other methods, it is reduced to the desired quantity.

For finishing a sample a riffle sampler is often used. This consists of a series of parallel troughs like a gridiron, the width of the troughs being at least four times the diameter of the largest pieces of ore that are being handled by means of it. As with the split-shovel, one-half the ore is retained in the troughs, and one-half falls through and is rejected. Each shovelful is evenly scattered upon the riffles, and care is taken not to heap the ore above the troughs.

Machine or automatic sampling.—It will be seen that the different methods of hand-sampling, especially for large lots of ore by coning and quartering, involve much labor; and it had been sought to overcome this by the use of machinery. A sample, taken from a stream of ore, is called a running sample, and is taken automatically by a sampling-machine. These machines are of two kinds.

- (1) Those which take part of the stream all the time.
- (2) Those which take the whole stream at frequent and regular intervals.

Since the stream of ore is not homogeneous, the first method is defective and the second generally preferred.

Fig. 15, called the pipe-sampler, is an example of the first type. The ore stream is delivered into the hopper at the top, and is split by deflectors, which eject half the stream at the sides of the tube.

The half retained is caught by the next deflectors below, that repeat the operation, and the division continues as the ore descends. The sampler here shown reduces the quantity of ore to one-sixteenth the original amount.

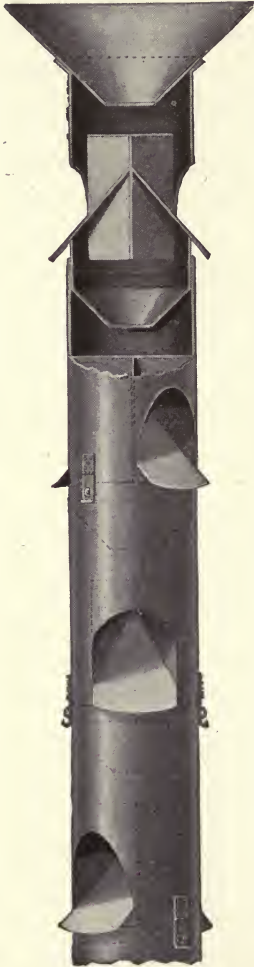

Fig. 15.
PIPE ORE-SAMPLER.

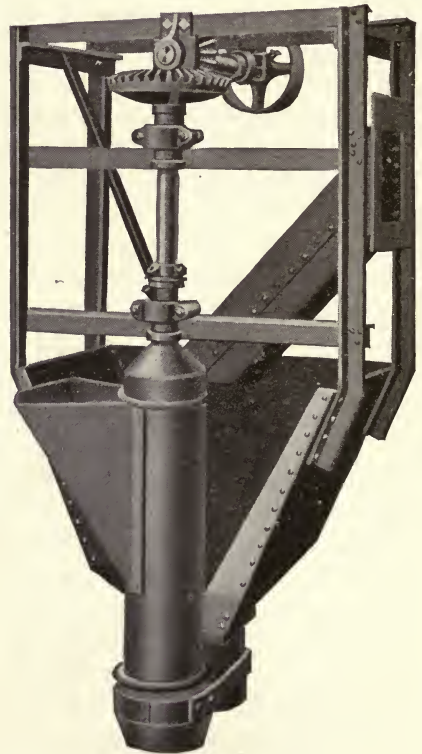

Fig. 16.
VEZIN AUTOMATIC SAMPLER.

The Veizin sampler (Fig. 16) is a sampler of the second kind. It consists of a tube carried by a vertical shaft making 30 revolutions per minute. Attached to the side of the tube and opening into it is a scoop. As the shaft revolves 'counter-clock-wise', it cuts the stream

of ore that is falling from the inclined feed-chute. The ore, thus intercepted, falls through the tube and becomes the sample, while the rejected portion, falling in the main hopper, is delivered by a pipe to

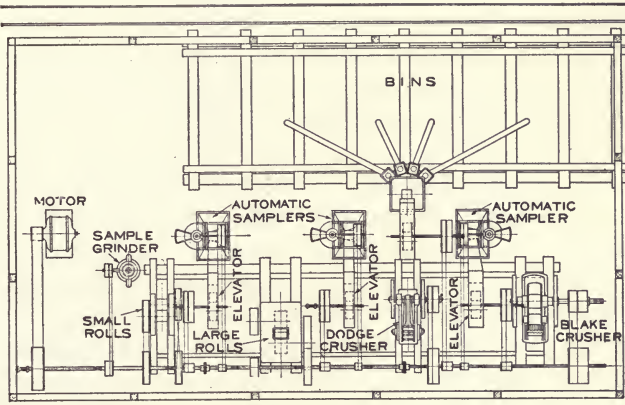

Fig. 17. SAMPLING WORKS (PLAN).

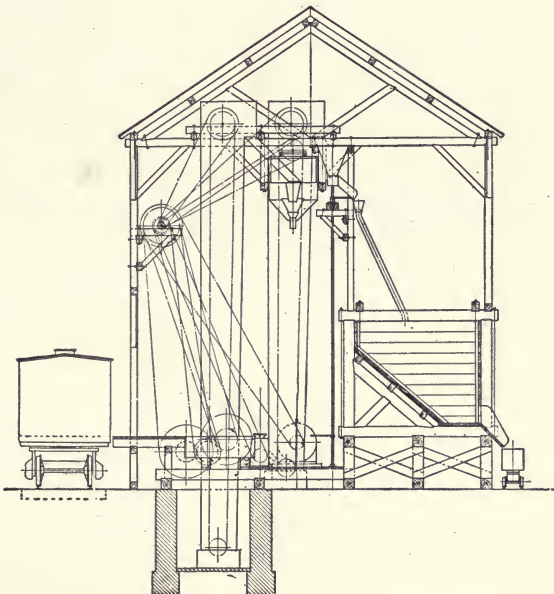

Fig. 18. SAMPLING WORKS (ELEVATION).

the bin. In the plan of a sampling works (Fig. 17) three automatic samplers are shown, the two first of which have double scoops. The ore is crushed finer after passing each sampler, and by the time three successive cuts have been made the sample is reduced to one two-hundred-and-fiftieth of the original weight.

Fig. 17 and 18 represent in plan and elevation a small sampling mill of a capacity of 10 tons hourly in use at a reduction works. The process in this case is as follows:

A car, after weighing, is unloaded into the storage bins of the works, and a sample consisting of one-tenth of the entire carload is retained in the car and the car then sent to the mill. The sample is held upon the floor until similar samples from all the cars containing ore of the same lot are added to it. This sample may weigh 10 tons. It is now put through a Blake crusher, and reduced to $1\frac{1}{4}$ -in. size. The ore from the crusher then is elevated and passed through a Vezin sampler, while the rejected portion goes to one of the sample-bins. The portion to become the sample, now weighing 4000 lb. or one-fifth the original weight, is sent to a Dodge crusher to be crushed to $\frac{1}{2}$ -in. size. It is elevated to a second Vezin sampler, where one-fifth is again cut out, reducing the amount to 800 lb. It next passes to large rolls that reduce it to pea-size, then by an elevator to the last Vezin sampler, where it is cut to 80 lb. It is now received upon the floor to be coned and quartered, and when reduced to 20 lb. in this way, is put through small rolls that crush it to 20-mesh. This is again reduced in quantity to 5 lb., put through a sample-grinder, mixed, quartered to 2 lb., ground by hand on a bucking-plate to 80-mesh size, mixed, and put in bottles or sample-sacks as in hand-sampling. The rejected portions of the ore are conveyed by gravity to any bin desired, and retained there until the ore has become the property of the reduction works by purchase.

Weight of ore.	Value in silver ounces per ton.		
	Highest 300 Average 50	Highest 3000 Average 75	Highest 10,000 Average 500
100 tons to 10 tons.....	Cocoanut	Fist	Fist
10 tons to 1 ton.....	Orange	Egg	Walnut
1 ton to 200 lb.....	Walnut	Chestnut	Chestnut
200 lb. to 5 lb.....	Pea	Wheat	Wheat
5 lb. to bottle sample.....	20-mesh	25-mesh	50-mesh
Bottle sample	80-mesh	100-mesh	120-mesh

In the progressive crushing, as described, it is observed that we

make the ore finer as the sample becomes smaller. This is to make sure of a constant ratio between the size of a single rich piece and the whole sample, that it may not produce an appreciable effect upon the assay-value of the sample whether such a piece be present or absent. The richer, and more 'spotty', or varied the ore, the finer it should be crushed therefore before it is cut or quartered. The table above shows how this is arranged in practice.

We may conclude that for accurate sampling the principal requirements are:

(1) The taking of frequent portions to insure an average of the whole stream that is undergoing progressive sampling.

(2) Thorough mixing of the ore to insure uniform richness.

Sampling of ores containing metallic substances.—This is an operation requiring a clear knowledge of the principles of sampling. We come upon these 'metallics' sometimes in the operation of sampling. They must be separated, cut smaller, and quartered down separately by a hand-method, and reduced in size, at the same rate as the fine ore. If fine substance is made by cutting up the metallics it can be united with fine ore. Often metallics are brittle, but with diligent work can be broken, cut, and 'quartered down' without serious difficulty.

Cost of sampling.—The cost of moving the ore cars, unloading into bins, returning the cars to the sampling-mill, and unloading the fractional part, usually one-tenth, retained, may be taken at 10c. per ton. The cost for hand-sampling the tenth part may be taken at 75c. per ton. Hence, for unloading and hand-sampling a 100-ton lot, the total cost would be 17.5c. per ton. At the Metallic Extraction Works, Cyanide, Colorado, ore was unloaded from the car to a feed-shoot, crushed to $\frac{3}{4}$ -in. size, automatically sampled, and delivered to storage-bins, for 11c. per ton. A charge of \$1 to \$2 per ton has been made for sampling, storing, assaying, and selling ore at custom works or sampling-mills, where the company has acted as selling agent and obtained the best possible price for the shipper. The price for sampling concentrate was 50c. per ton lower.

Sampling concentrate tailing, and ore-pulps.—Concentrate is sampled easily for it can be thoroughly mixed and sampled by hand. Tailing contains but little value, and needs no close attention. Ore-pulp flowing in a launder is often automatically sampled. When not so sampled, a bucketful, taken each hour from the stream, and all these samples united in one portion after decanting the water, may be used to determine the approximate daily average value.

13. SAMPLING METALS.

Metals may be sampled either in the solid or molten state.

Gold or silver bars or ingots.—These are sampled for assay either by granulating a small portion of them or by taking chip-samples from them. In the first case, while the metal is in a molten condition, a small ladelful, weighing an ounce or less, is taken from the crucible immediately after stirring it. This is poured into a bucketful of water thereby granulating the metal and forming particles of a variety of sizes, convenient for weighing and assay. Chip-samples are taken at points diagonally opposite on the edges of the bar, and a cold-chisel, cutting out a small wedge-shaped piece, is used for this purpose. The pieces are annealed and rolled into a ribbon for assay. The average assay-value of the two pieces thus obtained is taken as the true value.

Base-bullion.—This is lead that comes from silver-lead blast-furnaces, and it contains commonly 100 to 400 oz. of silver per ton. When poured into molds to be cast in bars, the silver segregates, and the exterior of the bar, that cools first, is richer in silver by several

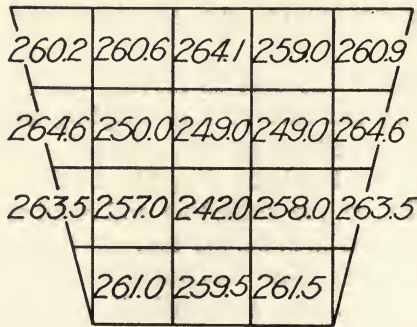

Average 258.2 oz. silver per ton

Fig. 19. DISTRIBUTION OF SILVER IN BAR OF BASE-BULLION.

ounces, than the central part. This is illustrated in the cross-section of a bar (Fig. 19), in which the center of the bar assays 10 ounces less than the exterior. Base-bullion is sometimes sampled by taking two 'chips' or punchings, one from the top and one from the bottom of each bar. The punch (Fig. 20), resembling a belt punch, is 8 in. long and removes a cylindrical piece of $\frac{1}{8}$ -in. diam. by about $1\frac{1}{2}$ -in. length.

From a carload lot of 400 bars, 800 of these chips would be ob-

tained. These are melted and the fused metal stirred in a plumbago crucible and cast into a bar. This is a sample of a 400-bar lot of base-bullion, equivalent to 20 tons. A better way of sampling, however, is to re-melt the metal in a large kettle (See Fig. 172), and to



Fig. 20. BASE-BULLION SAMPLING PUNCH.

skim and re-cast into bars for shipment. While casting the metal, a sample is taken from the molten bath and poured into a bullet-mold of such a size that each bullet weighs approximately a half assay-ton. This is trimmed to the exact weight for the assay.

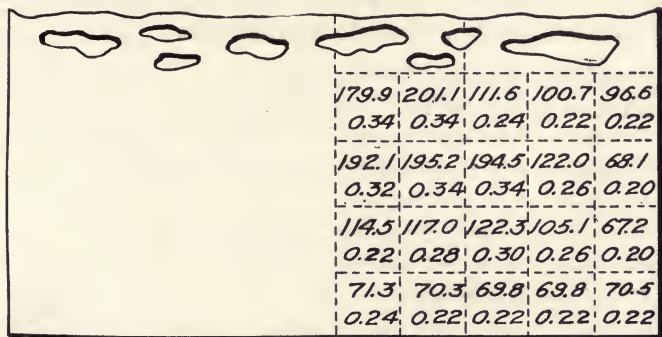

Fig. 21. SECTION OF BAR OF INGOT COPPER.

Copper ingots or anodes.—The segregation of gold and silver in copper ingots is even more marked than in bars of base-bullion. This is shown in Fig. 21, which represents the distribution of gold and silver in an ingot of blister-copper 5 in. deep. In this case, however, the interior is higher both in silver and gold. The usual way to sample such bars is to drill into them and retain the borings for a sample. Manifestly a sample like this is uncertain, and depends upon the selection of the place on the ingot for taking it. To obviate this difficulty, in sampling a lot, say of 100 bars, it is customary to drill into each succeeding bar at a different spot to obtain an average by so doing. It is preferable, however, to take the sample at the time the copper is melted and well mixed in the furnace by poling. As in the case of base-bullion, samples of copper are taken while

dipping or casting, one at the beginning, one when the charge is half removed, and one toward the end. The average of the three samples is regarded a correct representation.

Pig iron.—This is sampled and graded by inspecting its fracture and by chemical analysis. When an analysis is to be made, the sample is taken from the drillings of a small bar, molded while the metal is flowing from the furnace. The percentage of silicon determines the grade.

14. CRUSHING AND GRINDING.

The method and extent of breaking, crushing, grinding, or pulverizing ore depends upon the size best suited to subsequent metallurgical treatment. Ore comes from the mine already of a size that may need no further breaking if intended for smelting. Or it may come to the reduction-works as concentrate, fine enough for roasting or other treatment. Methods of breaking or grinding ore for further treatment, may be classified as follows:

- (1) Breaking for the blast-furnace.
- (2) Breaking for stall or heap-roasting.
- (3) Crushing for reverberatory melting or smelting.
- (4) Crushing for treatment in roasting-furnaces.
- (5) Crushing for distillation.
- (6) Crushing or grinding for amalgamation.
- (7) Crushing or grinding for leaching.
- (8) Grinding for sliming.

(1) **Breaking for the blast-furnace.**—The blast ascending through the charge carries away fine ore by the strong current and for this reason, and also for the reason that coarse ore makes an open charge that permits the free passage of the blast, coarse ore is preferred. It is desirable, indeed, to smelt ore as coarse as it comes from the mine, breaking only the large lumps with a hammer. When the ore is an oxidized one, and lumpy, the whole of it may be passed through a rock-breaker set for 2½-in. crushing. This is desirable only when the blast-furnace charge is too open, and when reduction, in consequence, is poor. Commonly the case is the reverse of this because of the large amount of fine ore which it is necessary to smelt. With a coarse charge it is desirable to crush also the fluxes, including iron-ore and limestone. When the charge is fine, or tight, the limestone may be fed in 50-lb. lumps, which though large pieces, become disintegrated in their downward passage by the heat that drives off the CO₂. Up to this time the lumps do duty in keeping

the charge open. To prevent the blast carrying away the finely pulverized ore, it is a good plan to wet it before feeding. The more effective way is to press the fine material into bricks, using a briquetting press (Fig. 164). The bricks become hard on drying and are unaffected by the blast. Briquetting adds about \$1 to the expense of treatment.

(2) **Breaking for stall or heap-roasting.**—This work may be done either by hand or in a rock-breaker. By the latter method the work is less costly but more fine material is made than by the former. Peters, in his 'Modern Copper Smelting' cites a case of breaking in a jaw-crusher in which the fine resulting amounted to 17.3%, while by spalling or breaking with hammers, only 9% was made. On the other hand, machine-crushing costs but 9c. per ton, while hand-spalling costs 35c. Peters states that, since 10% fine is sufficient for a finishing-covering for roast-heaps or stalls (See Fig. 27 and 28), any excess above this quantity should be avoided. This rule does not apply to fine material roasted separately in a reverberatory furnace (See Fig. 33).

(3) **Crushing for reverberatory melting or smelting.**—Fig 138 and 139 are views in elevation and plan of a furnace in which ore is melted or slagged to a liquid. Pieces as large as an egg melt easily in such a furnace. One great advantage that the reverberatory-furnace has over the blast-furnace is, that the damper of the furnace may be closed at the time of charging until the dust, arising from the charge when dropped into the furnace, subsides. Thus no appreciable loss of fine dusty ore results, whereas in a blast-furnace such a light material would be blown away.

(4) **Crushing for treatment in roasting-furnaces.**—Illustrations and descriptions of furnaces of this kind are given in the chapter on oxidizing-roasting. The ore must be crushed fine so that air can reach it readily to properly roast it. An ore consisting mainly of iron pyrite decrepitates in roasting, so that it is fine enough if crushed to pass a 2 to 3-mesh screen. Many ores and mattes need crushing to 4 to 6-mesh size. An ore containing blende or galena is compact, and when it must be roasted, especially if to be dead-roasted (that is, until the sulphur is eliminated), had better be ground finer, or to 10-mesh size. When an ore is to be subsequently treated by leaching, for which it should be more finely ground, the grinding can be done before roasting. It is a good plan, however, to grind to a coarse size for roasting and re-grind the product as fine as desired for the after-treatment. Ore should be ground no finer than needed for efficient roasting, since more dust is made by so doing.

An idea of the efficiency of the roast, and the necessary fineness of the particles can be obtained by examining the latter after the roast is finished. If imperfectly roasted, the particles have an unroasted or raw core or center. In the Stetefeldt furnace, the ore is ground to 20 mesh, since the time of roasting is confined mainly to the few seconds occupied by the fall of the ore particles from the top of the tower of the furnace to the bottom.

(5) **Crushing for distillation.**—The purpose of this is to prepare ore for the distillation of zinc or mercury. When zinc ore has been crushed to 8 to 14-mesh size it is fine enough for the preliminary roast and for mixing with coal in the subsequent treatment. Cinnabar ore is fine enough when 1 in. or less in size. It is generally divided into two or more sizes according to fineness, each size being separately treated in the retorts.

(6) **Crushing or grinding for amalgamation.**—The ore is milled or crushed in a stamp-battery (See Fig. 44 and 45). When comminuted to pass the battery-screen, a good deal of it is very fine, or 'slimed' as it is called. Slime is not objectionable when ore is passed over the usual amalgamated plate to collect the gold it contains. In silver milling, ore is first crushed in a stamp-battery, then re-ground in pans, thus further comminuting the coarser particles that pass through the battery-screens. Grinding in the pans is continued until the pulp is of 200-mesh size or finer, and feels smooth and free from grit when rubbed between the fingers.

(7) **Crushing or grinding for leaching.**—Ore that is to be treated by a leaching method should be ground so fine that the solution has access to the metal in the particles of ore. It must not be ground so fine as to retard the leaching by the slimed material intermingled with the sand. In the operation of leaching we are guided by the activity or nature of the leaching solution. The solution may contain chlorine, bromine, cyanide of potassium, hyposulphite of soda, common salt, or consist merely of water. With an active agent like chlorine the size may be less than with potassium cyanide. Again, ore may be porous, or the precious metal may be in a more soluble condition, or may be rendered so by a preliminary roasting. Thus Cripple Creek ore, crushed to 10-mesh for chlorination, is crushed to 30-mesh size for cyaniding. A point to be observed in preparing ore for leaching is to avoid making slime in crushing. Any considerable portion of finely ground or slimed material hinders percolation greatly. If grinding is performed by rolls a more granular product, containing less slime, is produced than by crushing to the same screen size with stamps. This is shown by the following screen an-

alysis. The two products indicated have passed through screens of the sizes specified, and the percentage of the various fine sizes contained are represented by weight.

TABLE SHOWING THE UNDER-SIZES RESULTING FROM CRUSHING.

Screen sizes.	Wet stamps.	Rolls.
	Crushed through 26-mesh screen.	Crushed through 23-mesh screen.
	Per cent.	Per cent.
Through 30, on 40 mesh.....	11.15	9.30
Through 40, on 60 mesh.....	28.53	41.85
Through 60, on 90 mesh.....	9.21	15.38
Through 90	51.11	33.47
	100.00	100.00

The ore used here is a conglomerate containing a little pyrite. The smaller quantity of slime produced by the rolls should be noticed.

If it is desired to obtain the maximum quantity of sand and the minimum of slime, then gradual reduction, or graded crushing, should be adopted. This consists in screening out the fine ore, coarsely crushing the residue, screening out its fine and then crushing what is left. By this means the ore, as soon as crushed to the desired size, is removed from further action of the crushing machinery and escapes unnecessarily fine comminution.

An illustration of how this is done to ore that is to be ground sufficiently fine for roasting and subsequent leaching, is the following system of dry-crushing. The assumption here made is that the mill is to crush 200 tons per day. The operation is divided into (A) coarse and (B) fine crushing.

A. Coarse crushing.—A 20 by 12-in. Blake rock-breaker crushes ore as it comes from the mine containing pieces as large as 12 in. diam. at the rate of 25 tons per hour. There are, however, clayey and talcose wet ores containing 25 to 30% moisture that stick to the rock-breaker, and are impossible to crush in the wet state. Such ore is first dried in a cylindrical dryer. The Blake rock-crusher is shown in perspective in Fig. 22 and in longitudinal section in Fig. 23. It consists of a heavy cast-iron frame, marked 1, within which is placed the fixed jaw 5, and the swinging jaw 2, and between them the ore is crushed. A shaft 36, eccentric where it passes through the pitman 3, causes this to rise and fall, producing a corresponding movement of the adjacent ends of the toggles 7, 7. As these rise, the effect is to push the jaw forward to produce the crushing movement. As the pitman and the toggles descend the jaw recedes, and

is pulled back by the spring rod 16, and the rubber spring 17. Fly-wheels 11, help and steady the movement. The machine is driven by the pulley 12, at 250 revolutions per minute. The movement of the lower end of the jaw is $\frac{1}{4}$ to $\frac{3}{8}$ in. For the breaker above specified, the discharge-opening would be 20 by $1\frac{1}{2}$ in. to crush to $1\frac{1}{2}$ -in. size. The receiving opening would be 20 by 12 in., and would take pieces as large as 12-in. diameter.

The ore, now crushed to $1\frac{1}{2}$ -in. size or finer, goes to rolls 36-in. diam. by 16-in. face, which supply 25 tons per hour to a revolving

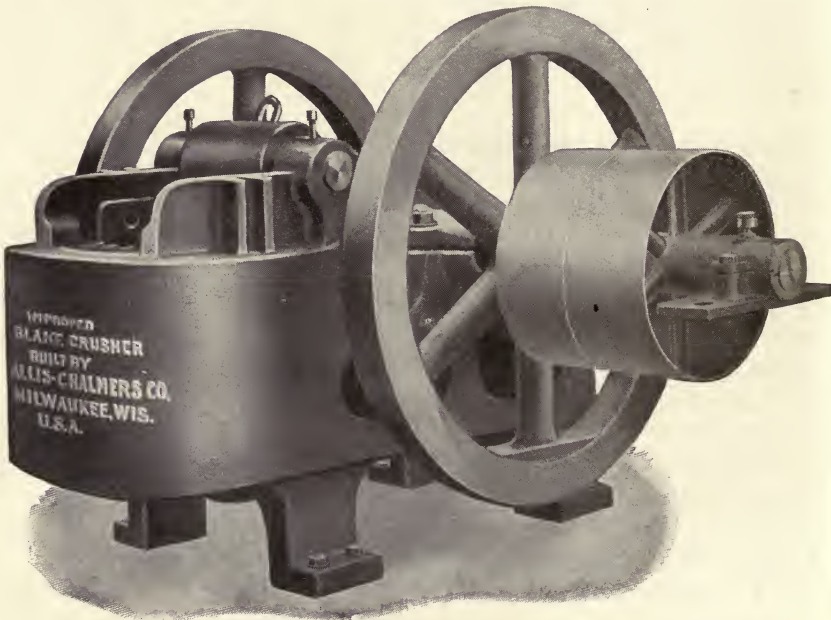

Fig. 22. THE BLAKE ORE-CRUSHER.

screen or trommel having $\frac{3}{4}$ -in. holes. A set, or pair, of such rolls of the belt-driven type is shown in Fig. 24. One roll is carried by its shaft in fixed bearings or boxes, and is driven by the large pulley. The other roll, called the movable one, is held to its work by powerful spiral springs acting on the shaft-boxes with a pressure of 15 tons upon each box. Thus the pressure of the springs is such that if a hard object, such as a hammer-head, were to fall between the rolls, they would open only under a pressure of 30 tons. The smaller pulley on the shaft of the movable roll is intended to keep the roll in motion at the speed of the other, but not for other work, the

power being mostly transmitted through the large pulley. The rolls (in Fig. 24), are covered by the housing. The feed-hopper of the rolls is seen immediately above the housing. As the ore drops from the rolls it falls through a chute to the boot of a belt or chain-elevator (See Fig. 189 and 191).

The material from the rolls is delivered or discharged through a chute into a Vezin sampling-machine (Fig. 16), making 40 revolutions per minute. This takes out one-fifth for a sample, and leaves four-fifths to go to the storage-bins. The sampling is completed by

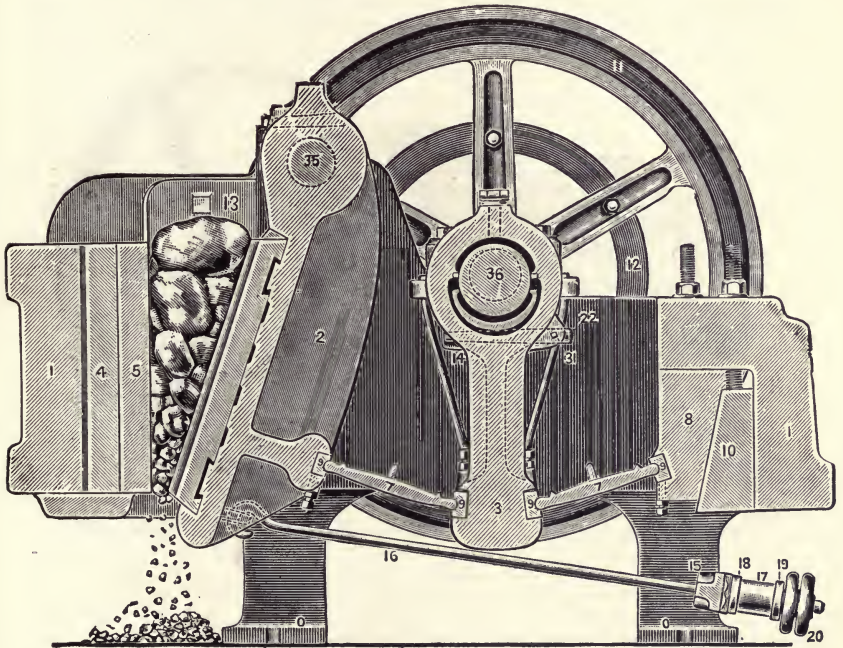

Fig. 23. BLAKE ORE-CRUSHER (SECTION).

the methods described under 'machine-sampling'. A single sampling-machine can easily handle the 200 tons crushed during the 10-hour day shift.

The ore $\frac{3}{4}$ to $\frac{1}{2}$ in. and less in size, is drawn as desired from the storage-bins into two-wheeled buggies, and dumped into the hopper of the cylindrical drier. A feeding-shoe or some other kind of automatic feeder, supplies it continuously to the drier, shown also at *f*, Fig. 110 and 111. This drier is 24 ft. long and of sufficient capacity to dry ore containing 6% moisture to 1% or less, at the rate of 10 to 15 tons per hour, heating it at the same time so that it will screen

readily. When in this condition the ore is 'lively', and will screen without difficulty, but if it were not for the drying, it would stick to the screen and clog it. The cost of this drying approximates 5c. per ton.

B. Fine crushing.—This work is done continuously. Fig. 25 is a diagram showing the series-crushing system used. The ore-supply from the drier goes to the roughing-rolls *a* which reduce it from 0.75 to 0.25 inch. The crushed ore is raised by the elevator to a trommel, or separating-screen, having screens of $\frac{1}{8}$ and $\frac{1}{2}$ -in. aperture, respectively. The first two-thirds of the screen takes out all material less than $\frac{1}{8}$ in., and the final size is all coarser than $\frac{1}{2}$ inch.

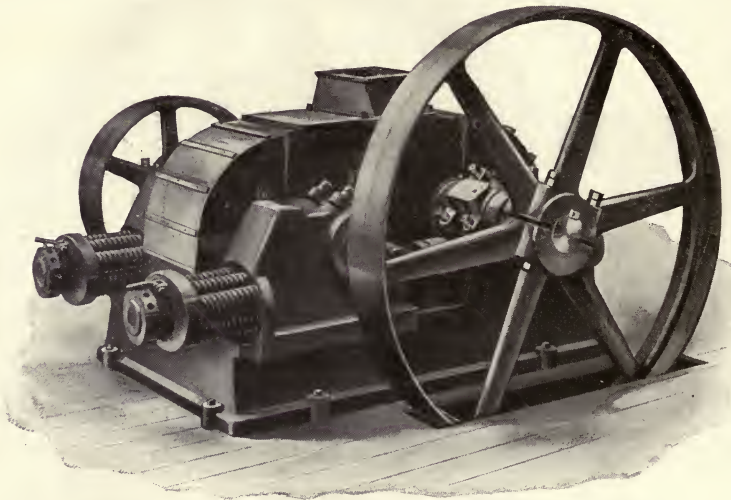

Fig. 24. CRUSHING ROLLS.

We thus get three products, an oversize from the coarser screen which goes back to the roughing rolls to be re-crushed; a screened product or under-size, which goes to the medium rolls *b*, set at $\frac{1}{8}$ in., there to be crushed and sent back to the separating-screen; and finally, an under-size through the $\frac{1}{8}$ -in. screen, fine enough to go to the finishing rolls. Until crushed so fine that it passes the finest mesh, the ore is returned to the trommel.

The fine product of the screen is raised by the elevator *f'* and the ore-stream is equally divided between the finishing screens *s''* and *s'''* which are provided with 30-mesh wire cloth. The undersize from these revolving screens or trommels drops into the storage bin *m*, while the oversize is conveyed to the finishing rolls, after which it goes again by elevator to the finishing screens. Thus nothing en-

ters the storage-bin except 30-mesh or finely ground ore (0.02-in. diam.), ready for further treatment.

We observe that any 8-mesh or finer product, that has been produced by roughing rolls, does not go to the medium rolls, and that any finished sand, in the 8-mesh product, is not forced upon the

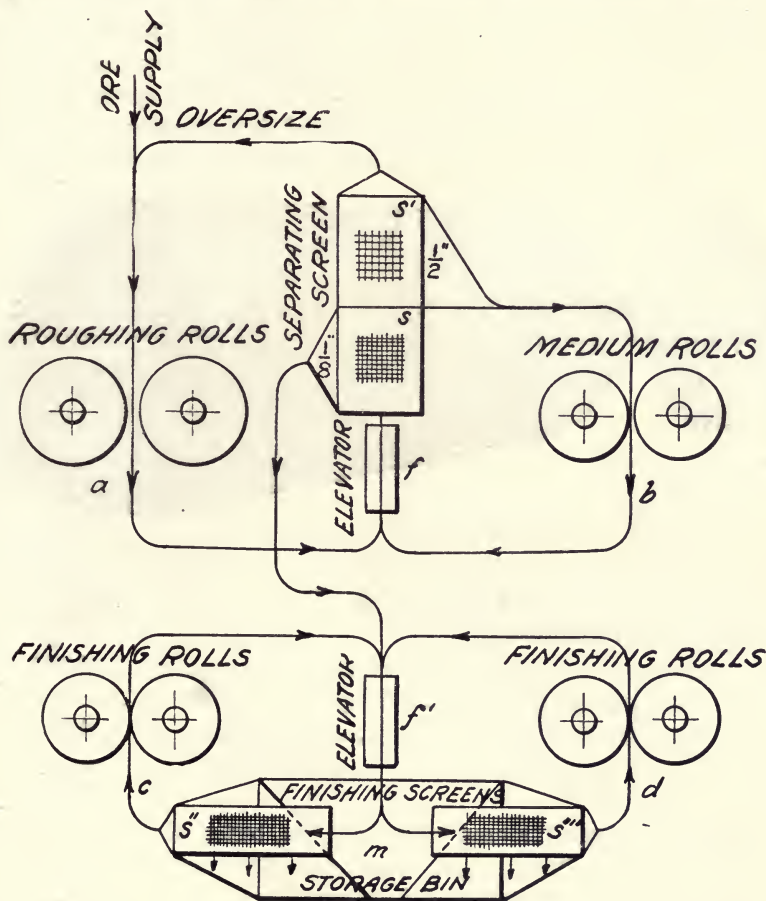

Fig. 25. FLOW-SHEET FOR DRY CRUSHING.

finishing rolls, but goes first to the finishing screens. Thus the moment a particle is broken to a finished condition, it passes to the finished-product bin without passing through the crushing machinery. One square foot of screen will separate 6 cu. ft. of product per 24 hours. The 200 tons required can be treated in 20 to 22 hours, allowing time for delays and repairs. This gives a capacity for each

set of finishing rolls of 5 tons per hour. The speed of the rolls varies with the coarseness of the material to be crushed. The coarse rolls, run at 600-ft. the fine ones at 1000 to 1400-ft. peripheral speed, per minute.

This system of graded crushing is preferable because the product contains a minimum of fine or slimed ore; and being granular, is more easily percolated or leached. As each piece or particle of ore is crushed by a single nip, the fine is separated by the screen and protected from unnecessary breaking with consequent waste of power. The chief costs in this system of dry-crushing, are those of labor, power, supplies, and repairs. These vary with the tonnage.

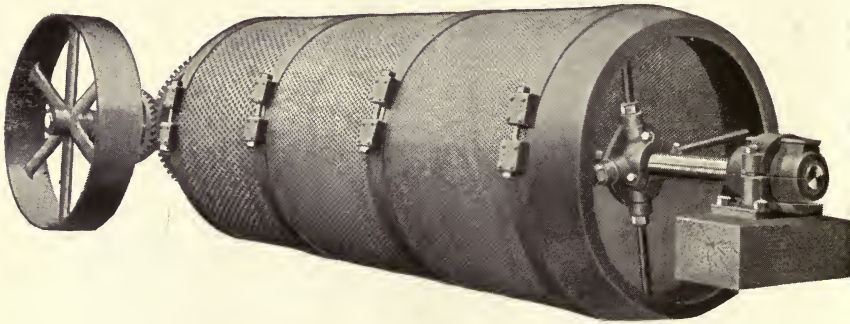

Fig. 26. TROMMEL OR CYLINDRICAL REVOLVING SCREEN.

The cost of crushing to 30-mesh size, in preparation for roasting or leaching, is as follows:

For coarse-crushing and automatic sampling...	\$0.106
For drying and fine-crushing	0.275
For power	0.105
	\$0.486

In round numbers the cost is 50c. per ton, but to this must be added general expense, including management, office expense, rates, taxes, insurance, cost of water, and improvements.

Besides crushing with rolls, after coarse-crushing, ore may be crushed by stamps or Chilean mills. Fig. 44 is a stamp-battery, a favorite and efficient machine; Fig. 100 is a Chilean mill. This will be described later.

(8) **Grinding for sliming.**—Ore frequently contains gold and especially silver so finely disseminated in the substance of the ore that grinding finer than 150-mesh is needed to unlock the minerals from the adhering gangue. While rolls or stamps grind ore to a

certain fineness, further grinding, after water-separation or classification of sand and slime, is performed upon the granular or sandy portion too coarse to pass uncrushed. Grinding-pans and tube-mills have been used for this purpose, and have proved most satisfactory. The tube-mill (Fig. 96), later to be described, is a favorite means employed for this purpose because of its great capacity, simplicity, and cheapness in repairs. The cylinder or tube revolves 20 times per minute, and half-filled with pebbles the size of the fist rolling over one another, effectually comminutes the ore particles. Grinding to any desired size, is done, and the coarser particles which escape grinding, are classified and returned to the machine for re-grinding.

PART II. ROASTING

PART II. ROASTING.

15. OXIDIZING-ROASTING.

This operation is also called 'calcining', though the term calcining is applied also to heating carbonates to expel carbon dioxide. We shall proceed to the chemistry of the process.

16. THE CHEMISTRY OF ROASTING.

The operation of roasting is for the purpose of burning or expelling the sulphur, which the ore contains, by the action of heat with the access of air. This can be done either when ore is in lump-form, in heaps, or when fine, by means of reverberatory furnaces. The various types of these furnaces are to be described and illustrated in the present chapter.

For the purpose of illustration, let us consider the action that takes place in a reverberatory furnace such as is shown in Fig. 31, 32, and 33. In this furnace the fire is at the end, and the charge is spread upon the hearth. As roasting proceeds, the roasted ore at the fire-end is withdrawn and the part remaining unroasted is moved from time to time toward the fire, fresh ore being constantly supplied at the upper end. After 20 hours, ore fed at the cool end, is in the hottest part of the furnace. Let us take for example an ore with a silicious gangue, containing mixed sulphides such as galena, blende, pyrite, and chalcopyrite. The silica tends to prevent sintering and makes the charge more open or accessible to the air. To do good roasting, certain requirements must be observed. First, the heat must be sufficient to start the roasting. Later, the temperature must be high to drive off the last of the sulphur. Air must be abundant, to oxidize the ore freely, and to carry away readily the products of the re-action. The surface exposed to the heat and air should be extensive. Finally, the ore should be stirred frequently, to bring fresh surfaces into contact with the air.

The ore is dropped upon the hearth at the cool end of the furnace, where the temperature (350°C.) is sufficient to expel moisture and start the reaction of combustion. In 10 to 15 minutes the charge

becomes hot enough for the oxidation of pyrite to begin, as evinced by the blue flickering flame that plays over the surface of the charge. Pyrite, under the action of heat, separates thus:



The sulphur expelled combines with oxygen from the air. An equivalent, or 32 lb. of sulphur, burning to SO_2 , yields 72,000 calories, or $72,000 \div 32 = 3220$ pound-calories per pound of sulphur burned. The SO_2 is removed by the draft. The remaining FeS and also CuS, the ZnS, and PbS, begin to oxidize, the activity of roasting being in the order here named. While oxidation proceeds with them all, the FeS is most easily roasted, while the ZnS and PbS are the slowest in parting with sulphur. Beginning, therefore, with the FeS we have:

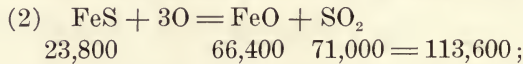

or in words the iron sulphide becomes oxidized to ferrous oxide, with the evolution of SO_2 , the reaction being accompanied by heat to the extent of $113,600 \div 32 = 3550$ pound-calories per pound sulphur burned, as explained in Part I, Section 3, under 'Thermo-chemistry'. The cupric sulphide of the chalcopyrite acts according to the formula:

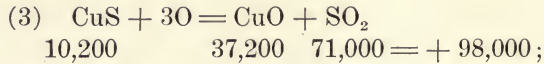

or, per pound sulphur, $98,000 \div 32 = 3030$ calories. The blende, under the action of the heat and air, is affected in the same way:

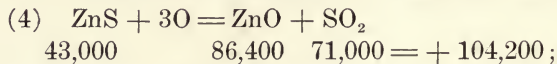

or, per pound sulphur present, 3420 calories. Galena also roasts according to the reaction:

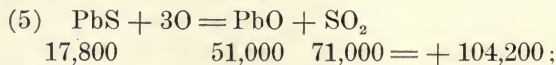

which gives us 3250 calories per pound sulphur. It will be noticed that the heat evolved per pound sulphur burned is much the same in each case; and hence the sulphide, containing most sulphur, gives off the most heat in roasting. These re-actions, especially of blende and galena, proceed gradually throughout the roasting operation. The air acts chiefly on the exposed surface, and the activity of the above reactions is accordingly increased by stirring the charge. The FeS that has been formed, as shown in reaction (1), and which lies upon the surface, is exposed to an excess of air. The FeS, in presence of the silica of the ore, acts by catalysis and is a sort of go-between for

the FeS_2 and the oxygen of the air. It finally becomes oxidized thus:

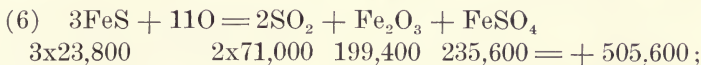

or, per pound sulphur, 5260 calories. This is observed to be a most energetic exothermic reaction. The products of the reaction are iron sulphate, SO_2 which is carried away by the draft, and Fe_2O_3 which is acted upon by more FeS when the two are stirred together as follows:

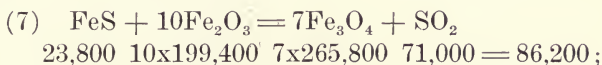

If the charge is not stirred, reaction (6) causes a red-colored product to form on the surface of the charge. This is the compound, Fe_2O_3 , but on stirring it decomposes into Fe_3O_4 as shown in equation (7), and the product becomes black. When roasted to excess, the product takes on this red color, undesirable in some roasting operations.

As the ore is moved to a hotter part of the furnace, the activity of the above reactions continue, and at an incipient red ($590^\circ\text{C}.$), iron sulphate, which has been formed in the ~~manner seen~~ ^{reaction (6)} begins to decompose, reacting on the cupric oxide as follows:

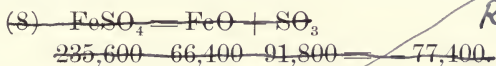

Read No. 9 below

Thus, as the SO_3 is given off from the FeSO_4 , and while in an ascendent condition, it is taken by the CuO , the reaction being an endothermic one. ~~Sulphate is formed thus:~~

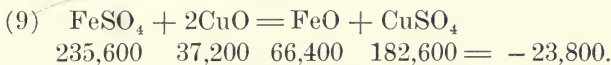

This reaction is ~~even more endothermic than the former~~, and hence is only a partial one. There remains uncombined some iron sulphate, which is decomposed by the heat thus:

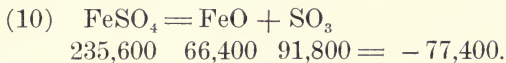

This also is an endothermic reaction.

At a slightly greater heat ($655^\circ\text{C}.$), the cupric sulphate, formed but a short time previous according to reaction (8), begins to decompose, and at a dull red heat ($705^\circ\text{C}.$), the corresponding decomposition of the cupro-cupric sulphate begins. These decomposition-reactions of the copper sulphate are complete at $850^\circ\text{C}.$, or at a cherry-red heat. To this point, they indicate the action that is going

on in a sulphatizing roast like that of the Ziervogel process to be later described.

At 850°C. the zinc and lead oxides, reacting on the copper sulphate that is being decomposed by the heat, begin to be changed to sulphates.

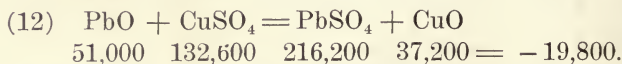
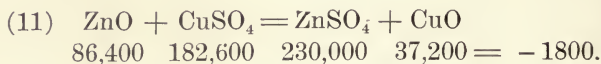

In general we may note that reactions (8) to (12), inclusive, are endothermic, and in place of helping along the roasting by heat developed, as shown in the early action of the charge, demand heat and absorb it as the result of the reactions. Fortunately these later reactions take place only at the hot end of the furnace.

As the charge is moved nearer the fire the sulphates completely decompose, the zinc sulphate doing so more readily than the lead sulphate. At 1050°C. (a dark-orange heat), copper oxide is decomposed to cuprous oxide, and ferric oxide to Fe_3O_4 , oxygen escaping at this high temperature.

At this stage the ore begins to fuse, if it contains lead, but when little lead is present, it only slightly agglomerates. If the ore contained much lead, even this temperature can not be attained without causing it to begin to slag. In that case the charge, rendered no longer porous or accessible to the air, necessarily ceases to roast, zinc and lead sulphates decompose imperfectly, and the sulphur is not well eliminated. It is hard to roast a leady ore well. On the other hand a zinc ore, free from lead, can and should be brought to a high finishing-heat when it is desired to decompose the zinc sulphate and remove the last portions of the sulphur.

Sometimes, with lead-bearing zinciferous ores, to be treated in the silver-lead blast-furnace, after roasting, the roaster is arranged with a fuse-box as shown in Fig. 33. The charge, which has been roasted on the roasting-hearth of the main part of the furnace, is moved from the hearth into the fuse-box, and melted after adding some silicious ore. The silica reacts on the zinc and lead sulphates thus:

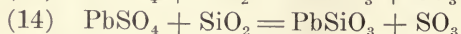
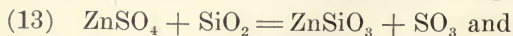

The sulphur is eliminated as sulphuric anhydride fume, and the resulting product is freed from sulphur. Zinc silicate enters slag as such, and is eliminated by that means. Lead silicate is reduced in the blast-furnace with the recovery of the lead. The charge, originally

pulverous, is now in the form of a slag, so that no loss of flue-dust results.

It has been found that with 2% SO_2 by volume, or 4.4% by weight, in the escaping gas, roasting is active. This corresponds to 23 lb. air per pound SO_2 or 46 lb. (570 cu. ft.) air per pound sulphur driven off. Calculating this for a 16-ft. McDougall roasting-furnace, treating 40 tons of ore per 24 hours, and roasting it from 35% down to 7% sulphur in the product, we have an elimination of approximately $\frac{1}{4}$ lb. of sulphur per second, which needs 142 cu. ft. free air, equal to 284 cu. ft. of escaping gas at 273°C ., a temperature which gives a maximum chimney-discharge as explained in the chapter on combustion. For a velocity in the stack and flues of 20 ft. per second as a maximum, this would require an area of 14.2 sq. ft., or a diameter, for a round stack, of 4 feet 3 inches.

When more than 46 cu. ft. of air per pound of sulphur is admitted, though roasting proceeds actively, owing to a good supply of fresh air and to the fact that the products of the reactions are removed promptly, still the furnace becomes cooled too much. If less air than this is admitted, roasting proceeds more slowly so that with 4% SO_2 by volume the roasting is slow, with 8% very slow, and with 9% it ceases entirely.

The various reactions described above need time; and the larger the body of ore, the longer the time must be to complete the roast. If a few grams of ore are roasted in the muffle, the operation is complete in half an hour, but in a hand-reverberatory furnace (like that shown in Fig. 32), roasting 14 tons per day, the operation takes 20 hours.

The temperatures at which the reactions described above take place are as follows:

At 150°C . the odor, due to the volatilization of some of the first or loosely-held sulphur in pyrite, can be detected.

At 350°C . the sulphur of the sulphides, particularly of the iron sulphide, begin to burn.

At 590°C . the iron sulphate, formed at a lower temperature, begins to decompose.

At 655°C . copper sulphate (CuSO_4) (see equation 8), decomposes.

At 705°C . cupro-cupric sulphate ($\text{Cu}_2\text{O}\cdot\text{SO}_4$), formed at the time copper sulphate is formed (see equation 9), begins to decompose.

At 850°C . copper sulphates are entirely decomposed.

At 835 to 850°C . the maximum amount of soluble silver sulphate, (AgSO_4) (when silver is present in the ore) is formed.

At 1050°C . copper oxide (CuO) is decomposed to Cu_2O .

At 1100°C. ferric oxide (Fe_2O_3) is decomposed to the next lower oxide Fe_3O_4 .

Reactions in blast-roasting copper-bearing sulphides.—When a mixture of iron and copper sulphide is pot-roasted, desulphurization proceeds rapidly if the ore be wet and silica added; otherwise it proceeds slowly. For these reactions we have:

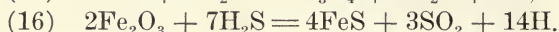

When air is blown into the charge both hydrogen and H_2S burn. In a well-burned charge some Fe_2O_3 can be seen at the sides and top where cooled by radiation, but Fe_3O_4 reacting on FeS gives FeO as follows:

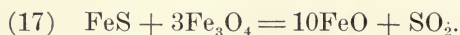

This reaction is exothermic and at a high temperature with silica would form ferrous silicate, again producing heat. Indeed, in action the formation of this, with the consequent sintering, can be seen spreading as the burning proceeds.

17. ROASTING ORES IN LUMP FORM.

Heap-roasting.—Roasting in heaps sulphide ores containing copper is an operation that must be performed with knowledge and care, in order to obtain satisfactory results. Before selecting this method a careful study of the environment must be made. It can not be adopted in a settled country where the fumes would be a nuisance, or where it would be likely to injure live-stock, or vegetation, or damage crops. In the arid and scarcely settled Rocky Mountain region, of the United States and Mexico, it may be employed to advantage. Around an installation of moderate size, where no more than 25 tons of sulphur escape into the atmosphere daily, the area affected may be not more than four miles in extent; and the site for the roasting-plant may be chosen with this in view. Often the prevailing winds blow from a single quarter, and permit placing the roast-piles where they give little offence. The location should be chosen with regard to the needs of the plant itself, so that smoke and fume will seldom be driven into the buildings.

A roast-yard should be of ample size, approximately level, and so drained that the surface water shall not flow over it. At Jerome, Arizona, a track follows the contour of the hillside, and the roast-heaps are ranged close beside it so that the ore is trammed conveniently to the pile, unloaded upon it, and roasted. After roasting the ore is loaded at these piles, without waste of labor, and is trammed

to the smelter. The roast-heaps are so far apart that the fume from one pile does not interfere with making another.

A roast-pile 40 ft. wide and 6 ft. high, containing 240 tons, will burn 70 days. To this time must be added 10 days for removing and re-building. This equals three tons of ore roasted per day.

In preparing a roast-pile, a foundation is first provided, by leveling the ground and making a surface of clayey loam. Upon this is placed a layer of fine ore 3 or 4 in. thick upon which the pile is to be made. This layer gradually roasts, and as fast as this occurs, it is removed and sent to the furnaces, and fresh fine is used in its place. The ore is often hauled to the ore-heap in carts, or brought in wheelbarrows, or conveyed along a system of tracks from the higher ground adjoining, or from the mine. This is shown in Fig.

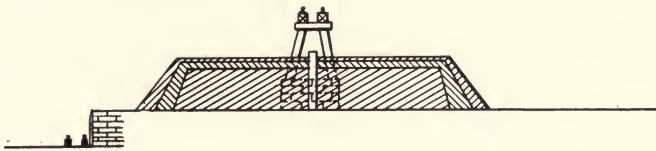

Fig. 27. ROAST-YARD WITH TRESTLE (CROSS SECTION).

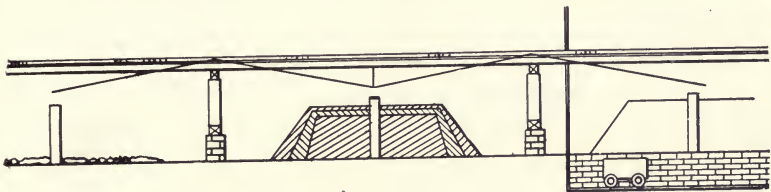

Fig. 28. ROAST-YARD WITH TRESTLE (LONGITUDINAL SECTION).

27 and 28. The bents, as shown in Fig. 28, are 36 ft. apart, having trussed stringers 10 by 12 in. to support the tracks over the roast-heaps. In Fig. 28 a completed head is shown at the right, in the middle is the cross-section of another heap, and at the left one just started. Fig. 27 represents a section of a heap and the track that runs past every heap, by which the roasted ore is taken away. In constructing the heap, a turn-plate, similar to that shown in Fig. 30, is placed across the track at the desired point, and a temporary track of stout rails, supported on temporary trestles, run out from the main track at right-angles.

The required height of the pile depends upon the character of the ore. An ore of 15% sulphur may be made into a pile 9 ft. high, while massive pyrite requires but 6 ft. for the best conditions and

thorough roasting. Upon the bottom, above described, is placed the fuel for starting the burning. This consists of a layer of wood 4 to 8 in. thick, a 4-in. layer being sufficient for the high-sulphide ores. The wood may be of any kind and length, where ore rich in sulphide is to be roasted. Cheaper wood, such as crooked branches, logs, and old tree-trunks can be used toward the center. The best pieces should be selected for the borders. The interstices between these closely-packed pieces may be closed by placing in them fine sticks, brush-wood, or chips, so that the ore will not fall through. Three chimneys 8 in. square, made of four old boards, nailed together, are set upright on the layer, and connected to channels below to create a draft through the wood when the pile has been fired. In Fig. 28 one of these three chimneys is shown. They also can be made of round sticks wired together, or of waste sheet-iron, bent in cylindrical form.

It must be noted here that often too much wood is used. About one cord is required for 40 tons of ore. It must be remembered that the wood is merely to start the burning of the pile. It soon burns out, but the ore continues to burn by its own action. The more massive or sulphurized the pyrite, the less wood is needed. The pile should be kept burning uniformly, and no attempt should be made to hasten the process unduly, since, with an excessive heat, the ore fuses, causing the action to stop. The coarse ore, broken so that no pieces are more than 4 in. diam., and varying from that size down to 1 in. diam., is dumped upon the layer of wood. The pile, built to the required height with as steep an angle at the sides as will stand, forms a shapely frustrum of a pyramid with sharp corners. Upon this, as shown in both figures, is placed ragging (made by screening out all the ore between one inch and one-fourth inch in size), forming a layer over the top and at the sides, thicker at the bottom and thinner toward the top of the slopes. Outside this is spread a layer of fine ore of less than one-fourth inch diameter screened from the ragging, making a thin coating over the exterior surface.

The pile is fired at the different channels around the edges, putting in some kindling wood to start combustion and selecting a time of quiet weather. After 4 to 6 hours, the fire having become well distributed through the pile, more fine ore is put on the steep sloping sides of the pile, thin above and thick below. The heap, especially at first, must be closely watched, fine being applied to check the draft where too vigorous, or holes being opened in the covering to draw the fire in the direction of places where it is not active. Fine is used freely to control the fire, throwing it on with a shovel

wherever needed, along the borders, at the sides and top of the heap. One may go upon the heap to regulate the combustion, by taking advantage of the wind blowing the smoke to one side.

Moderate rains and snow have but little effect upon the roasting; a high wind is apt to stop the burning on the windward side. This may be prevented by a temporary fence placed as a wind-break. Abundant rains tend to leach out and wash away copper sulphate. Where such conditions exist the heaps may be roofed over, or where this is thought to be too great an expense, some saving can be made by draining through ditches to a launder containing scrap-iron, upon which the copper precipitates. In the dry region of the Western United States, rains are moderate, and there are long, dry periods. In countries like Mexico, that have a rainy season, heap-roasting can be suspended until the rains are over.

Wherever possible roast-heaps should be left undisturbed until the completion of the roast, but if ore is badly needed, it may be taken from the roasted and cooled portions of the pile, without disturbing the action of the hot core, still burning. The best way is to start roasting operations several weeks in advance of the probable need of the smelter, so as to have available a sufficient supply of well-roasted ore. With care it should be possible to roast 90% of the ore in the pile, including the fine. When removing the ore, any unroasted pieces, which feel heavier than the well-roasted ore, can be sorted out and thrown upon the next roast-heap.

Heap-roasting of matte.—Matte can be well roasted in lump form, but unlike ore, it requires two or more burnings. After the first firing, in spite of care, matte shows but little the change it has undergone. At the second burning, using a larger quantity of wood, the result of the first burning begins to show. A large portion of the twice-burned material is found to be light in weight and porous, and to contain no unburned core. In fact the thoroughness of the roast may be judged by feeling of the lumps with the hand. If well roasted lumps are broken, they no longer show the raw core at the center.

The bed of wood can be prepared for matte as for ore, but the pile is smaller, being only 12 ft. square by 6 ft. deep, with a single chimney at the center. The broken matte, with the raw fine spread over it, is covered with the finer portion of the roasted ore. The burning of the heap lasts 11 days, and when ended, the heap is taken down, and the imperfectly roasted part made into a new pile, and the roasted matte sent to the furnace. It is a good plan in constructing the new pile to introduce one or two layers of chips or bark, for

a reducing effect upon impurities like arsenic, and for producing a more uniform heat throughout the pile. Finally, after this burning, a large portion suitable for use can be sorted out and the part still incompletely burned can go to the next heap.

Stall-roasting.—In stall-roasting, instead of roasting the ore in an exposed heap, it is enclosed within walls that form stalls, and contain flues for the admission of air to the ore, and for the escape of smoke to a main flue and tall stack. The strong draft thus created shortens the period of burning, and also removes the noxious fumes to the upper air. Each stall consists of a paved area, as shown in Fig. 30, $6\frac{1}{2}$ by 8 ft. and 6 ft. high, open at the front,

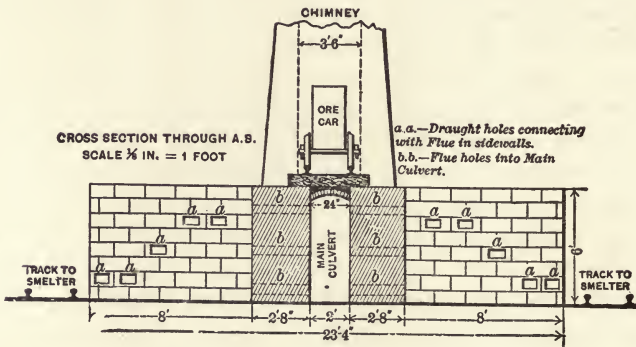

Fig. 29. ROASTING STALLS FOR LUMP ORE (SECTIONAL ELEVATION).

to retain the contents, which is closed by a temporary wall, loosely built at each charging.

Fig. 29 and 30 represent, in sectional elevation and in plan, a battery of stalls for roasting ore. Fifty-six such stalls roast 100 tons of raw ore daily. Each stall holds 20 tons and requires 10 days to burn and remove the contents, which, with a 10% allowance of time for repairs, gives an output of two tons per day each. The stalls are built of rough masonry, or of slag-blocks laid in clay mortar that are cast at the works. The stack is $3\frac{1}{2}$ ft. inside diameter, and 75 ft. high.

To charge a stall, the floor is prepared with large irregular pieces to form a rough flue or passage from front to back and two transverse ones, by which air can enter at the bottom. In the passages kindling wood is laid. The remainder of the floor is covered with a thin layer of long thin sticks of wood split from logs and poles (See Fig. 30). The stall is now filled with coarse ore and ragging

(1 to $\frac{1}{4}$ -in. size), distributed through the mass. While partly filled, single small sticks of wood are placed at the back and sides as well as occasional sticks at the front. The front wall is also carried up with the larger pieces of ore. The filling completed, a single car-load of ragging is added above the ore, then a 3-in. layer of shav-

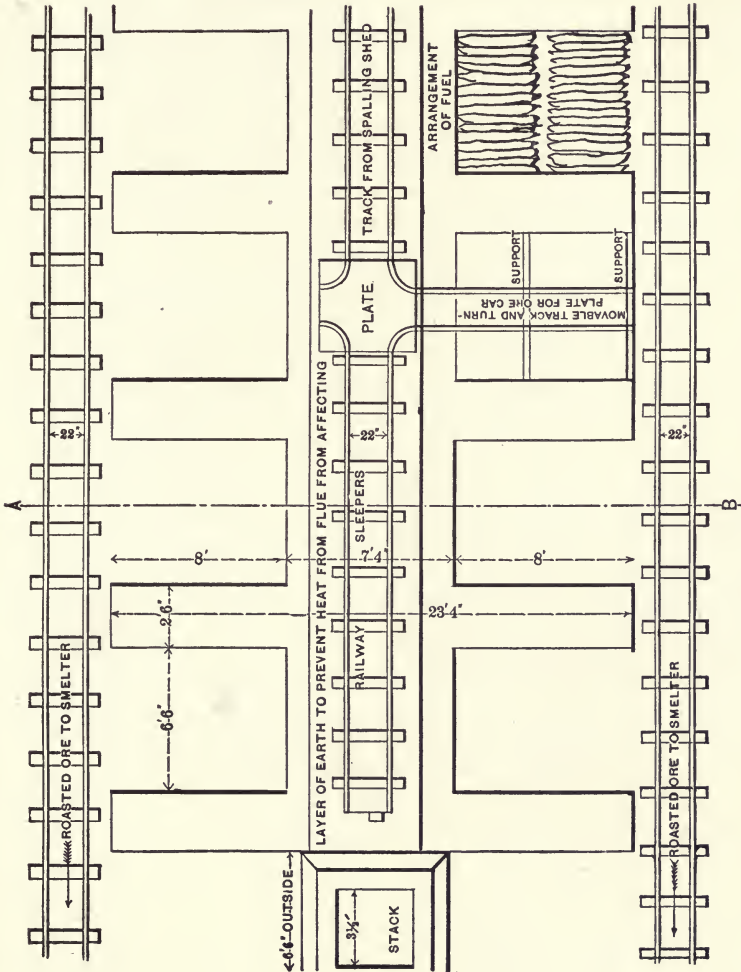

FIG. 30. ROASTING STALLS FOR LUMP ORE (PLAN).

ings, bark, and chips, then a layer of fine ore that can be roasted with care, and finally a coating of well-roasted ore. A sheet-iron cover on this, luted round the edges to the walls, is of great benefit. The air enters at numerous places. It enters beneath the ore by the rough channels, above described, through the interstices of the temporary

front wall, and through openings, *a* Fig. 29, in the side walls. The smoke leaves by the openings *b* into the main culvert.

The wood of the stall having been ignited at the front near the bottom, the roasting proceeds rapidly, and, by the end of the fourth day, the heap is burning throughout. Successful burning is indicated by the swelling of the contents and the rising of the surface, sometimes to the extent of a foot. Because of this swelling, the front or temporary wall should be braced with wooden braces to oppose the outward thrust. When, on the other hand, the burning proceeds too rapidly, no such swelling occurs, but instead, the surface subsides. Subsidence is due to the melting of ore owing to the great heat, and is an indication that roasting is imperfect. The heat can, however, be regulated by the use of fine ore to stop cracks, and by closing the passages to the draft openings *a*.

If the ore were left to burn and cool slowly, it would require 15 days to do this. In order to hasten matters, the front portion of the ore as it cools may be removed, taking care not to penetrate beyond the cold portion. Beginning at about the fourth day it is possible to take ore away, so that in seven or eight days the stall is again empty.

The ore is brought to the stalls by a track above the culvert or mid-flue. While a stall is being filled, a turn-plate, as shown in Fig. 30, is laid down with a branch-track, so that the ore can be conveyed above the stall and dumped into it. Tracks are also provided at the floor-level of the stall, and by these the roasted ore is conveyed to the blast-furnaces.

Cost of heap-roasting.—We find the cost of roasting at Ducktown, Tennessee, to be 42c. per ton. Peters gives as an average cost for fuel, labor, and supplies, 48.5c. per ton, with common labor computed at \$1.50 per day. Heap-roasting often can be done by contract to advantage. At the United Verde, Jerome, Arizona, 75c. per ton was the contract price.

Cost of roasting-stalls.—Peters gives for the cost of building 56 stalls a total of \$3303.80, or about \$60 per stall. To the total should be added \$400 for the cost of the stack.

Cost of roasting in stalls.—This may be estimated at 50c. per ton, with common labor at \$1.50 per 10-hour day.

Relative advantage of heap and of stall-roasting.—Heap-roasting has the advantage that it requires only the necessary site, and needs no investment for plant. The method is a simple one and the result is satisfactory. On a small scale, primitive methods of handling materials are sufficient, but for a large scale we must not forget the cost

of grading, of trestles, of tracks, etc. Stall-roasting saves much time, requiring 10 days as against 70 days for heap-roasting. In large plants, where from 10,000 to 50,000 tons are in process of treatment, heap-roasting may cause the locking up of several hundred thousand dollars in the heaps. By reducing this to one-seventh by stall-roasting, an important saving is effected. In stall-roasting the stack removes the fume, and the entire contents of the stall becomes roasted, including the fine, which is more thoroughly roasted than in heaps. The elimination of sulphur is perhaps a little less thorough in stalls than in heaps. In stalls, rain and snow have little effect on the process, and in a moist climate the consequent leaching causes no trouble. For stall-roasting one-fifth cord of wood per stall is enough for charging, or 1% the weight of the ore roasted, while in heap-roasting average practice calls for $2\frac{1}{2}$ per cent.

18. ROASTING OF ORES IN PULVERIZED CONDITION.

General.—This work is performed in furnaces, generally of the reverberatory type, the ore being exposed upon a hearth to the action of the flame and air. The reactions by which the ore is roasted are given in section 13, on 'Chemistry of roasting'. The ore if not already fine, is crushed to the size designated under 'Crushing for treatment in roasting furnaces'. In these various furnaces advantage is taken of the heat developed by the oxidation of the sulphides. If the percentage of sulphur is high, this is often enough to supply the required heat (after combustion has once started) without the aid of extraneous fuel. Thus, in the McDougall roaster, after the furnace has been heated, an ore containing 25 to 30% sulphur continues to roast by its own heat.

The various mechanical furnaces roast ore cheaply, but for ores containing lead, which agglomerate, roasting-furnaces that are mechanically stirred do not give such satisfaction as hand-reverberatory roasters. With a slight accession of heat above the normal, caused by the lack of care in firing, the ore is liable to agglomerate, and eventually to stick to and collect upon the hearth. In the hand-reverberatory roaster the hearth is accessible, and when this occurs the furnace can be used until the matter becomes serious, then the accumulation can be removed by 'cutter-bars'. On the other hand, such an accumulation soon stops the movement of a mechanical roaster. To remove it a flat bar of iron may be attached to one of the rabble-arms in the place of a rabble-blade. This is made stout enough to plow up the accretions and by setting it in different positions on the arm, the hearth is finally cleared. This device has not,

however, proved to be altogether successful. The hand-reverberatory works well on ores that need a high finishing heat to break up the sulphates. Zinc ores are of this kind. Such temperatures are destructive to any kind of mechanical iron stirrer.

We may classify roasting-furnaces into: (A) hand, and (B) mechanical-roasters.

19. HAND-OPERATED ROASTERS.

The long-hearth reverberatory-roaster or calciner.—In this furnace the charge is dropped and removed at intervals. The essential features (See Fig. 31 and 32), are a floor, or hearth upon which lies the ore spread over the entire surface of large area, a 'fire-box' at one end, a space below the fire-grate called an 'ash-pit', and a wall separating the fire-box from the hearth called a 'fire-bridge' (or simply a 'bridge'). The whole furnace is covered by a flat arch, or 'roof', against which the heat of the flame is reverberated or thrown down, upon the charge. Thus the flame imparts heat during its entire passage over the ore to the outlet-flue at the opposite end of the hearth, where it escapes by a flue to the stack. These furnaces are distinguished from the reverberatory smelting-furnaces shown in Fig. 139, by the relatively small grate-area, and the flat hearth at the level of the door-sills.

The figures represent, in sectional plan and in longitudinal sectional elevation, a long-bedded reverberatory hand-roaster. Disregarding the fuse-box, Fig. 33 gives a good idea of its appearance. The width inside for convenience in stirring and moving the charge, should be 14 ft., while the length is designed according to the character of the ore it is to treat. The length of the hearth must accord with the quantity of sulphide the ore contains, and consequently the heat the ore develops in roasting. Without the oxidation of sulphur the fire would not maintain enough heat to roast the ore more than 32 ft. distant from the fire-bridge. The heat-generating power of the ore depends upon the percentage of sulphur contained but is greater when the sulphur is in the form of the loosely-held first equivalent. An ore containing only 10% sulphur would be roasted to good advantage in a short furnace. The length of the first hearth of the furnace shown in Fig. 31 is 16 ft. Where 15% sulphur is present it is proper to add another hearth, making a furnace 32 ft. long. A 20% ore would work rapidly on a three-hearth furnace; and ore containing 25% sulphur or more, a four-hearth furnace, as shown in the figure, making a total length of hearth of 64 ft., which is suf-

ficient for any ordinary ore. Hearths of greater length have been tried, but have not been found satisfactory.

The stack, proposed by Peters to furnish draft for two roasters,

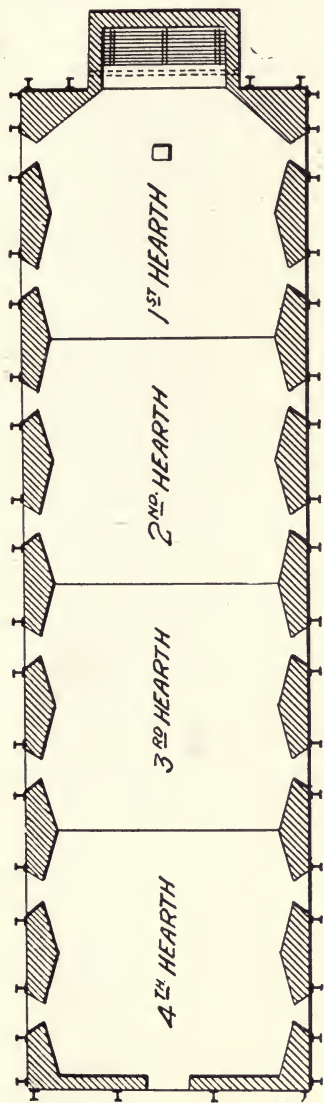

FIG. 31. REVERBERATORY ROASTING FURNACE (PLAN).

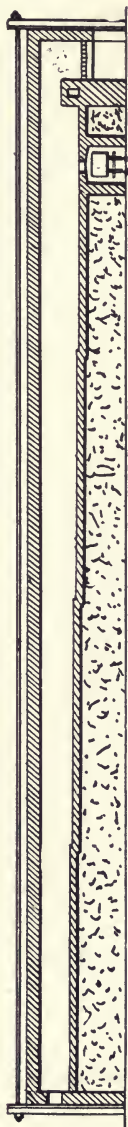

FIG. 32. REVERBERATORY ROASTING FURNACE WITH FUSE-BOX.

is 42 in. square inside and 65 ft. high. The cost, together with that of the connecting flues, he gives as \$728, and the cost of each reverberatory roasting-furnace, \$2713. A two-furnace roasting-plant

with building and accessories would cost approximately \$10,000.

This type of furnace has several advantages in the roasting of ore. The operation is started at a low temperature at which there is but little tendency for ore to cohere or agglomerate. The pulverous condition causes a thorough contact with the air, and makes it easy to rabble the ore. There is a saving in fuel, for this length of furnace reduces the temperature of the escaping products of combustion to 270°C. There is thorough stirring and turning, resulting from the movement of the charge toward the fire-end of the hearth. The firing is uniform and there is economy in repairs due to the uniform and moderate heat of the furnace at the rear where red brick can be used. Moreover the heat near the bridge can be readily increased to decompose sulphates and to agglomerate if fusible, which improves it for treatment in the blast-furnace.

Construction of furnace.—The cast-iron side-door frames are set 6 ft. apart and opposite (See Fig. 33). The doors are made from plates of sheet-iron and are removable by means of a 'lifter'. The floor of the furnace is divided into hearths or divisions, separated by steps with a 2-in. drop, so that successive charges, kept on separate hearths, do not mix with one another to the detriment of the roast. Sometimes these steps are omitted, but in that case the charges must still be kept separate. The furnace is strongly stayed by 'buckstaves' which are tied across by tie-rods to resist the expansion due to the heating of the brickwork, and to take the thrust of the arched roof. Through the walls of the fire-box, openings 2½ by 4 in. are often left for the admission of air above the level of the fire. The bridge has a passage through it to cool it, with side openings 2½ by 4 in. by which air can be introduced beneath the flame and in contact with the ore. These openings furnish air, which, together with that which enters through the fire, produces an oxidizing atmosphere at the hearth. The fire-box, bridge, and the first 16 ft. of the hearth should be of fire-brick. Beyond this, red brick of the better quality may be used, both for the roof and for the pavement of the hearth. All brick must be laid in clay, not in lime-mortar. A charge of ore is kept in the hopper at the flue-end of the furnace ready to be dropped upon the hearth when needed. The finished charge is removed through the discharge-opening into a car or wheelbarrow standing below.

Operation of furnace.—Assuming that the furnace is in regular operation, the charge on the first hearth is withdrawn by pushing aside a square cast-iron plate that covers the discharge-opening; and with the aid of a long-handled paddle and rabble, the roasted

charge on the first hearth is raked into the tram-car beneath. The paddle used for the purpose has a handle made of $1\frac{1}{4}$ -in. pipe 16 ft. long. It has a blade 6 in. wide by 18 in. long. The rabble, really a



Fig. 33. REVERBERATORY ROASTING FURNACE WITH FUSE-BOX.

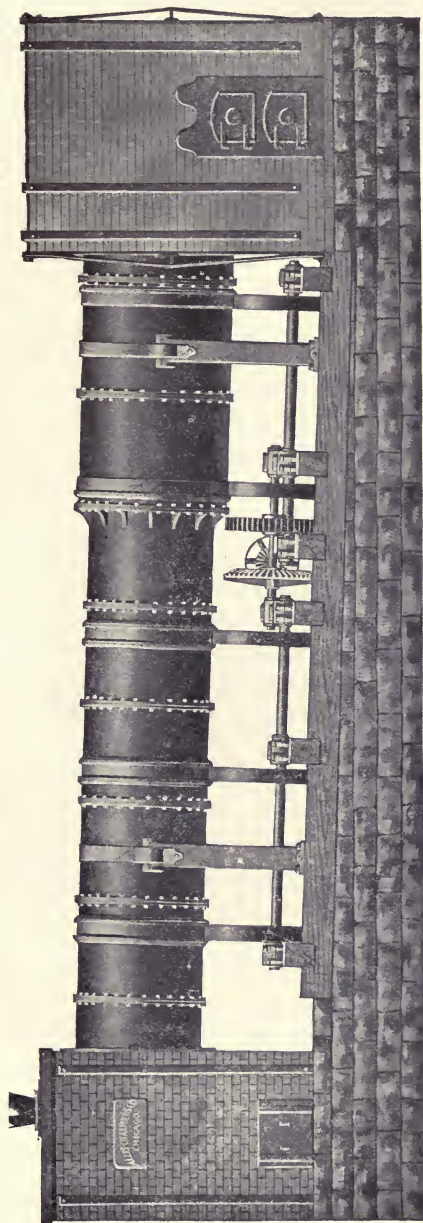

Fig. 34. WHITE-HOWELL ROASTING FURNACE.

hoe, has a handle of the same length and a blade 6 in. wide by 10 in. long. The hearth being thus cleared, the charge on the second hearth is transferred to it by means of the paddle. In the same way the content of the third hearth is transferred to the second, and the fourth to the third, thus leaving the last hearth empty. The charge is dropped in from the hopper, and by means of the paddle, spread out on the fourth hearth. This moving down of the charge occurs every 4 hours, so that if we charge 2 tons, we roast 12 tons daily. From the 12 tons daily charged into the furnace we may obtain 10.2 tons of roasted ore, the difference in weight being due to the loss of sulphur, etc. Besides the movement necessary to advance the ore through the furnace the charge must be stirred or raked at least every 20 minutes. The proper fuel for the furnace is a free-burning semi-bituminous coal, which should be burned in a shallow bed, 6 to 8 in. thick upon the grate, and it should be added every 15 minutes. A roaster consumes 5000 to 6000 lb. coal per 24 hours. With an output of 12 tons daily this is a consumption of 21 to 25% of the ore charged. The cost of roasting a copper sulphide ore in a long-bedded reverberatory furnace is \$1.81 per ton ore charged. If the ore contains lead (which makes it slow and more difficult to roast), the cost may rise to \$2.25 per ton.

Reverberatory furnace with fuse-box.—This is an ordinary long-bedded roaster to which has been added a slagging-hearth or fuse-box. Fig. 33 shows in perspective such a furnace, 75 ft. in total length. Its roasting-hearth is 57 ft. long by 15 ft. wide inside. Next comes the slagging-hearth 26 in. lower, inside dimensions 11 by 13 ft. Separated from the slagging-hearth or fuse-box by the fire-bridge is the fire-box with grate-dimensions of 8 ft. by 2 ft. 10 in. or 23 sq. ft. area. In the fuse-box a high temperature, sufficient for melting or slagging the roasted ore, is produced, so that the fire-bridge must be furnished with a water-jacket, or coil of water-cooled pipes inserted within the brick-work of the bridge, to protect it from the corrosive or scouring action of the slag.

Ore, in the hopper at the fuel-end, is dropped upon the bed of the furnace, and roasted as in the ordinary roaster. When roasted to this extent, it is discharged into the fuse-box where the temperature is high enough to melt it down. When melted it is skimmed or withdrawn by means of a rabble. Certain ores containing blende, that in roasting produces sulphate difficult to decompose, are roasted and then slagged. Silica, which may be in the ore, or may be added in the fuse-box, reacts according to reaction (13), or when lead sulphate is present by reaction (14), thus eliminating sulphur. The

chief objection to such treatment is that there is loss of silver and lead as mentioned under 'Chemistry of roasting'.

20. MECHANICAL ROASTERS.

These may be divided into:

(1) **Revolving cylinders**, set nearly or quite horizontal, and revolving on the long axis with

(a) Continuous discharge, as the White-Howell and the Argall.

(b) Intermittent discharge, as the Bruckner.

(2) **Automatic reverberatory roasters** or calciners with continuous discharge having:

(a) Straight-hearths, as the Brown-O'Harra, the Wethey, the Edwards, the Merton.

(b) Curved or circular-hearth, as the Brown-horseshoe, the Pearce-turret, and the McDougall.

Besides these may be mentioned the Holthoff and the Raymond, the hearth of which itself revolves, and also the Stetefeldt shaft-furnace in which the ore is showered down a shaft.

The White-Howell furnace.—Fig. 34 is a longitudinal elevation of this furnace. It consists of a cylinder, 50 in. inside diameter by 34 ft. long, set at an inclination of $2\frac{1}{2}\%$, supported on friction-rollers carried on the driving shaft. At one end is the fire-box, at the other a dust-chamber which connects by a flue to the stack. The hotter end of the cylinder, near the fire-box, is of larger diameter, to permit of its being lined with brick, thus leaving the cylinder of uniform interior diameter throughout. Projecting, longitudinal, fire-brick ledges, set spirally, raise the ore and shower it back through the flame as the cylinder revolves, so as to roast it more rapidly. The unlined part for the same reason is furnished with longitudinal, cast-iron, projecting shelves. Ore is fed at the flue-end, by means of a screw-feed (See Fig. 194), and when dropped into the revolving cylinder, travels along, discharging at the fire-box end. Just before it reaches the fire-box it passes out from the cylinder to a brick chamber below, and is withdrawn from that, when cool. The furnace makes much flue-dust. It is used chiefly for chloridizing-roasting, upon ores containing but little sulphur, and has a capacity of 50 tons per 24 hours for low-sulphur ores.

The Bruckner roasting-furnace.—This consists of a brick-lined cylinder, supported by and revolving on four rollers or carrier-wheels. As in the White-Howell furnace, there is a fire-box at one end, and a flue at the other. The flame from the fire-box is drawn

directly through the end-openings of the cylinder to the flue. The furnace treats the ore in charges that require 24 to 48 hours. The

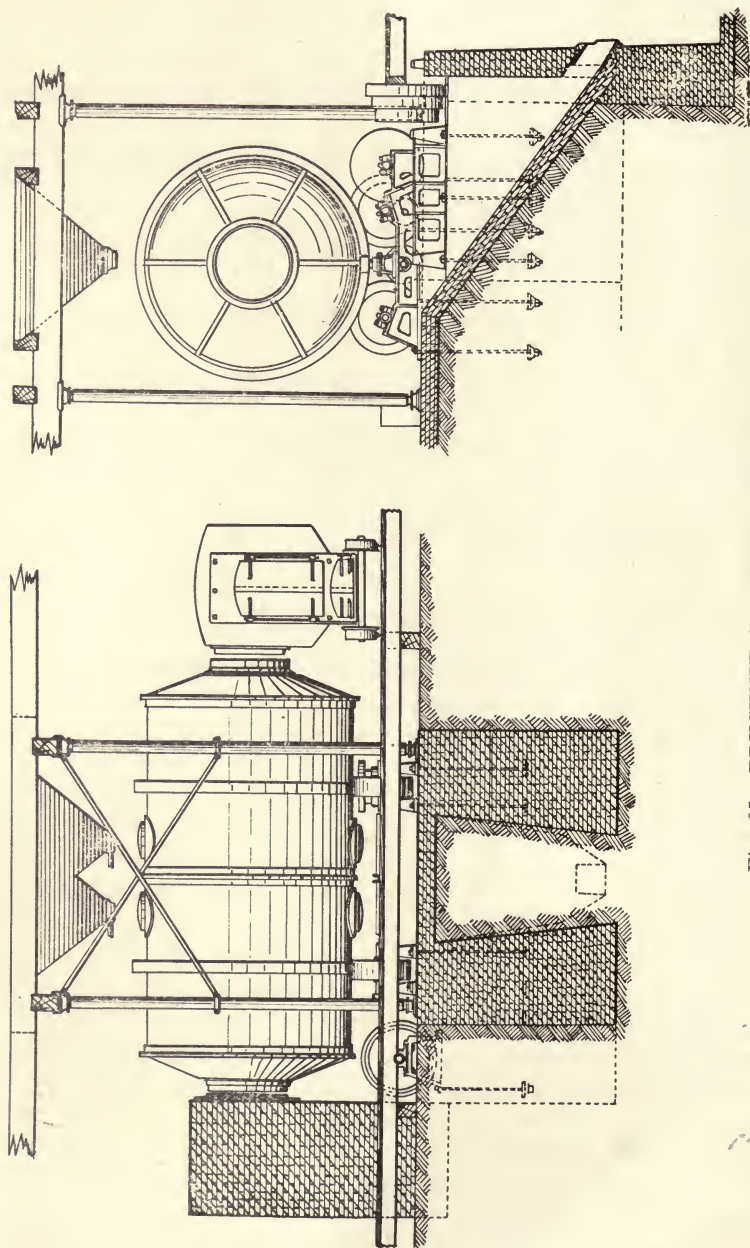

Fig. 35. BRUCKNER ROASTING FURNACE.

cylinder is provided with man-holes for charging and discharging the ore, the ore being first put into a double hopper from which it is quickly drawn when needed.

Fig. 35 shows the end and side of the furnace, indicating foundations in section. In the end-view at the right, the fire-box is removed. The cylinder, $8\frac{1}{2}$ ft. diam. by $18\frac{1}{2}$ ft. long, has end-openings 3 ft. diam. for the entrance and exit of the flame. It is driven by a worm-gear, the motion being communicated to two of the carrier-wheels on the common shaft and transmitted to the cylinder by the friction between the bearing rings and the carrier-wheels. The fire-box is a movable one that can be set aside when it is desired to reach the interior of the cylinder.

The present practice is to revolve the cylinder slowly, say once an hour, since the contents, even at this speed, is constantly shifting and representing new surfaces to the air. The old way was to revolve it once in four minutes. At the time of discharging, the speed should be at least one revolution in 2 to 4 minutes to discharge the ore quickly. This adjustment is made by throwing in a clutch by means of a quick-working mechanism. All the man-holes are opened, and it takes but few revolutions to discharge the cylinder. The ore falls into a pit below, whence it can be withdrawn to tram-cars for use. Charges that contain lead are liable to agglomerate, even with cautious firing, and to 'hang up', that is, adhere in a layer to the brick-lining. Should this occur, the movable fire-box can be pushed aside and the layer removed by long chisel-ended slice-bars. The attachment to the brick-work is so slight that, when the layer is cut from end to end, even at one place, the key or continuity is broken and the mass falls. Thus it is easily dislodged and by further rolling breaks up and is ready for continued roasting. A moderate cohesion of the fine particles does not present a good roast.

Operation.—The charge of 20 tons having been dropped into the cylinder from the hopper, the man-holes are closed and vigorous firing begun to start the ore to burning by its own oxidation, which begins at a barely visible red. This takes about six hours, the necessary temperature being attained first at the fire-box end and extending then to the flue-end. The charge thus started burns by its own heat 12 hours longer and the fire meanwhile is withdrawn from the fire-box. Indeed the reactions are so vigorous that the charge must be closely watched and the air-supply regulated lest agglomeration occur if the ore be a leady one. As the heat toward the end of this stage diminishes, firing is resumed, increasing the heat gradually, 6 to 8 hours more, to the finish. In this way sulphates,

formed early in the roast, are decomposed, and a good result is obtained. The whole cycle of operations takes 24 to 36 hours for copper ores and 48 hours or more for leady ores. For copper ores it is sufficient to reduce the quantity of sulphur to 7 to 8%, and for leady ores to 3 to 5%. The charge is removed by revolving the furnace rapidly, and after 10 to 15 minutes little is left to mix with the next charge. To charge the cylinder again, all but two man-holes are closed, and the cylinder is revolved to bring these directly under the hopper-spouts. The hopper-slides are withdrawn and the ore is quickly run into the cylinder and is ready for firing on closing the man-holes. These operations of charging and discharging need not take more than 20 minutes. For copper sulphides, roasted in 24 hours, the furnace capacity accordingly is at least 20 tons daily, and for leady sulphides roasted in 48 hours, 10 tons.

The cost of roasting leady ores is 85c. per ton, and for copper sulphides roasted to 7 to 8%, 42c. per ton. The cost of one of these roasters, installed, may be estimated at \$3000.

The Wethey roasting-furnace.—Fig. 36 is a perspective view, and Fig. 37 a cross-section of this furnace which consists of two, superimposed, straight hearths, heated by fire-boxes placed at the sides of the upper hearth. The roasting is done on the upper hearth; and the lower hearth is for cooling the ore after it has been roasted. The upper one of the two hearths, each of which is 121 by 12 ft. in size, is held between heavy transverse I-beams above and below, as shown in Fig. 37, which tie the upright buckstaves and support the hearth. The roof of this hearth is so suspended from the upper I-beam as to leave slits the entire length of the hearth; and through these project the ends of the rabble-arms which rest on carriages. The stirring blades, or rabbles, within the furnace, are set diagonally upon the rabble-arms (see the detail of such an arrangement for a Pearce-turret furnace shown in Fig. 42). The ends of the rabble-arms are attached to endless chains, which drag them along the upper hearth, stirring and gradually moving the ore forward. They return by the lower hearth upon which the ore, from the finishing end of the upper hearth, falls through an opening. Here it is again moved along, stirred, cooled, and finally discharged into a hopper, thence to be drawn into two-wheeled buggies and transferred to the leaching-vats. The endless chains pass around sheaves at the ends of the furnace, and around sprocket-wheels at the driving end which impel them. The rabble-arms are so arranged that they can be removed readily without disturbing the carriage connections. There are two rabble-arms, and these pass along the hearths at the rate of

100 ft. per minute. The blades of one rabble are set at the opposite angle to those on the next, so that the ore tends toward neither side. To hasten the cooling of the ore upon the lower hearth, that it may be ready promptly, for further treatment, water-cooled pipes are

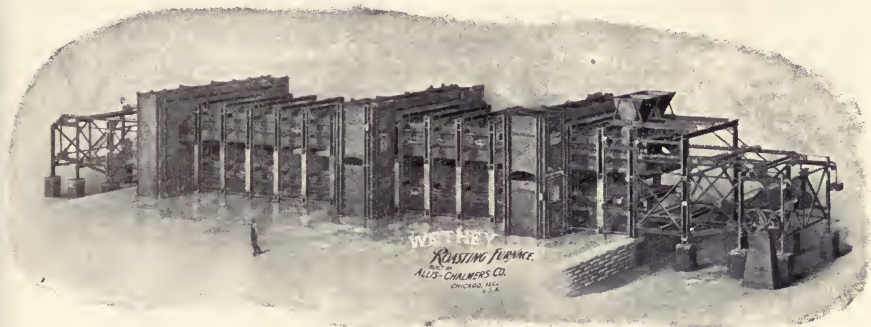

Fig. 36. VIEW OF WETHEY ROASTING FURNACE.

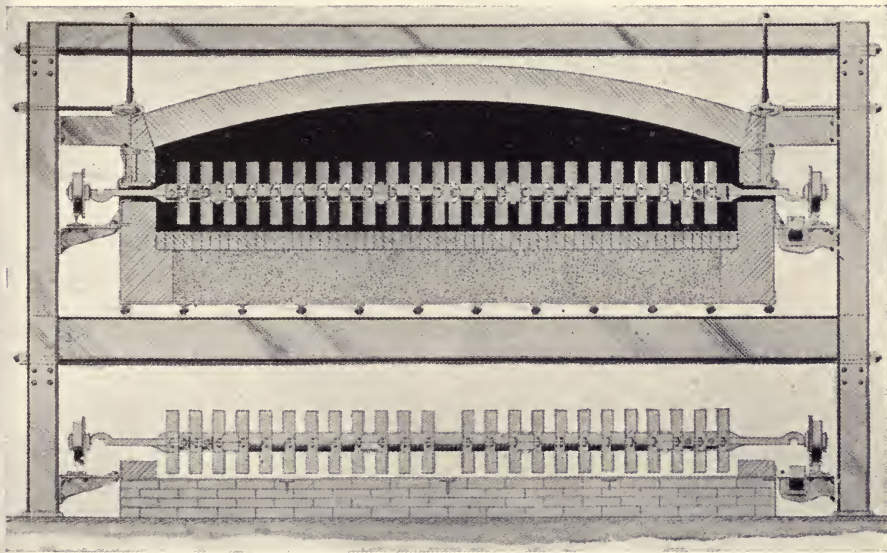

Fig. 37. CROSS-SECTION OF WETHEY ROASTING FURNACE.

laid the length of the hearth in grooves in the brick pavement flush with the top surface. The ore is regularly fed to the furnace from the hoppers by automatic feeders at the driving end (shown at the right in the perspective view, Fig. 36), and is heated by two sets of fire-boxes, one of which is at the feed end, the other half way along

the hearth. The flame from the fire-boxes descends to the hearth by a flue crossing the roof (See Fig. 36), then moves horizontally to the left, where by a flue at the end it escapes to the stack. Thus the ore and flame move in the same direction over the roasting-hearth. At each end of this hearth flap-doors of sheet-iron are hinged. These hang by the top edge of the sheet, and close the ends of the furnace at all times except when the rabblers enter or pass out of the furnace. The doors are lifted by the rabble, but drop again as soon as it passes. It might be thought that the slits, each 120 ft. long, would admit too much air and injure the draft, but the furnace is found to work well

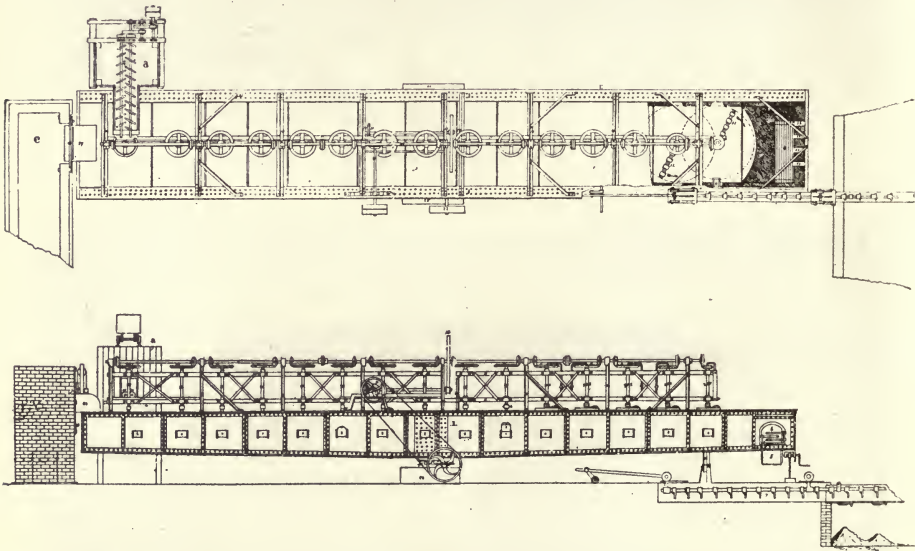

Fig. 38. PLAN AND ELEVATION OF EDWARDS ROASTING FURNACE.

notwithstanding this feature. The rabblers are in the open air more than half the time, and have a chance to cool after each passage through the furnace. We estimate the capacity of this furnace, roasting ore containing $\frac{1}{2}$ to $3\frac{1}{2}\%$ sulphur that needs 13 to 15 sq. ft. hearth-area, at 100 tons per 24 hours.

The Edwards roasting-furnace.—This is a single-hearth reverberatory furnace with hearth dimensions 57 ft. long by 6 ft. wide. Fig. 38, in plan, shows a portion at the fire-box end, the feeding mechanism and the cooling floor in section. The elevation shows the side, constructed like a plate-iron beam, the stirring mechanism and the conveyor for transferring the roasted ore to the cooling-pit. Fig. 39 is a transverse section of the hearth showing the details of

the stirring mechanism. The slope of the furnace can be changed a little by tilting. This regulates the rate of travel of the ore through the furnace; but for a given kind of ore, this slope, once determined, is not again changed. The furnace has a slope of 2 in. per foot toward the discharge or fire-box end. The stirring and propulsion of the charge is affected by means of rabblers fixed to vertical shafts, as shown in the elevation of Fig. 39, and in the plan of Fig. 38. The rabblers at the fire-box end are water-cooled, and this is found especially necessary where a high finishing heat is needed. The blades or plows of the rabblers can be easily replaced through the doors adjacent to them. The figure indicates the hearth as broken away, at the discharge end, to show two of the rabblers in plan. The last

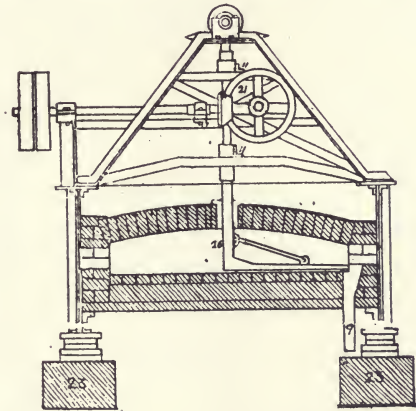

Fig. 39. CROSS-SECTION OF EDWARDS ROASTING FURNACE.

rabble sweeps the roasted ore into the discharge shoot, and the push-conveyor then moves the ore to the cooling-pit. The bottom of the conveyor-trough is furnished with slides, by means of which the ore can be dropped at any desired point on the cooling-floor. The ore is fed to the furnace from the feed-hopper, by an endless-screw conveyor which discharges into a feed-opening in the roof of the furnace. The smoke is carried off by a flue. The furnace takes 1 hp. to operate, and has a daily capacity of 25 tons on sulphide ore of 30 to 35% sulphur. The roasted ore contains 3 to 8% of sulphur. The moving parts are durable, and the furnace has proved efficient in practice. Large installations, of the duplex type with a double instead of a single row of rabblers, and of hearth-dimensions 120 by 12 ft., have been built for a daily capacity of 60 tons. These furnaces do not have the tilting hearth.

The Pearce-turret roasting-furnace.—The word ‘turret’ has reference to the circular form of the furnace. Three types have been developed, namely, the one-deck, the two-deck, and the six-deck or

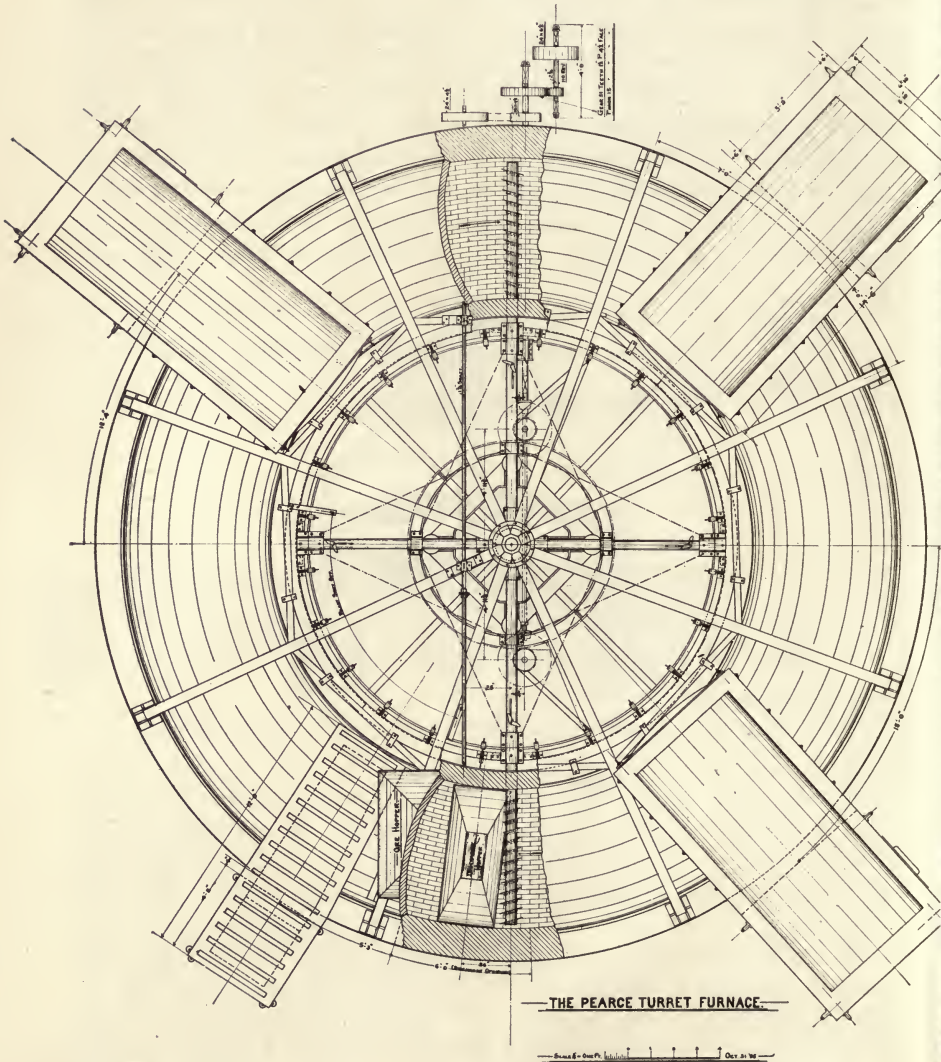

Fig. 40. TWO-DECK PEARCE-TURRET ROASTING FURNACE (PLAN).

six-hearth furnace. The greater the number the hearths, the more economical the furnace is as regards fuel and output. On the other hand, the multiplicity of hearths makes it more complicated, and

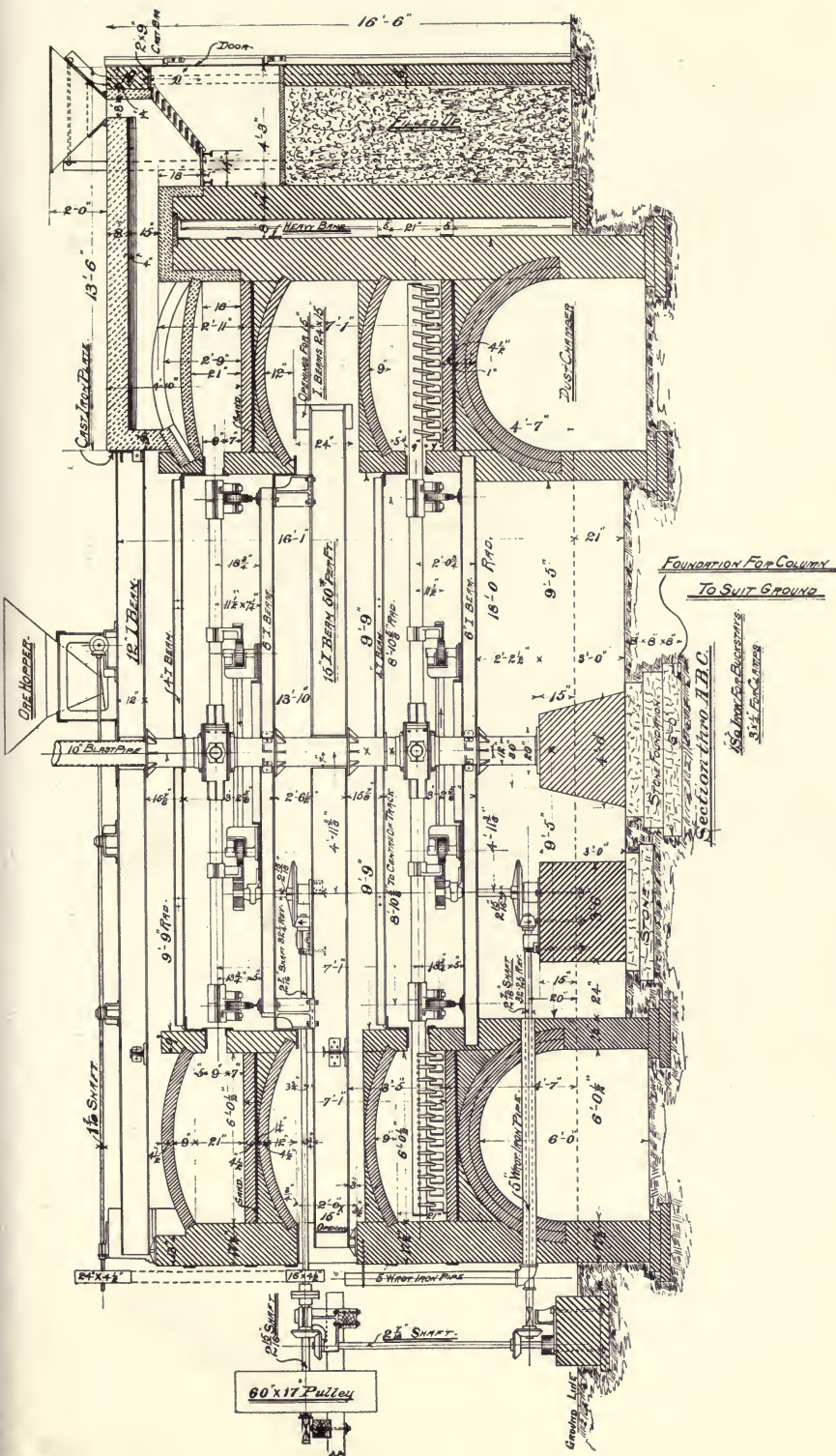

FIG. 41. TWO-DECK PEARCE-TURRET ROASTING-FURNACE (ELEVATION).

causes more flue-dust by the repeated dropping of the ore from hearth to hearth.

We shall now consider the two-deck type shown in Fig. 40 and 41. Fig. 40 is a plan, with opposite portions broken away to expose the hoppers and the rabble. Fig. 41 is a central sectional elevation through a fire-box and the hearths. To understand these views will require careful study. There are two superimposed annular hearths with space between for the 15-in. I-beam supporting the upper hearth and a flue-chamber below. Referring to the plan, the ore-hopper, partly broken away, is shown at the near side. Next, at the left, is the outlet-flue with its barred top, for the escaping gases; and at the right, where the furnace is broken down to the lower hearth, is shown the discharge-hopper. The ore is fed continuously from the ore-hopper (See Fig. 41), through the roof to the upper hearth until, having made its circuit, it falls through a transverse slit to the lower hearth. Here, as before, it is stirred by rabbles and moved forward until, having again made the circuit, it is received into the discharge-hopper of the lower hearth.

There are two rabble-arms for each hearth. Of these, the upper two are shown in the plan. The lower two are at right angles to the upper ones and are shown in the elevation. Each pair of rabble-arms is screwed into a central hub, that revolves on a fixed central column. A gear-wheel on the rabble-arms, in connection with a driving mechanism, moves the rabble at the rate of about one revolution in two minutes. As will be noticed in the plan, Fig. 40, and in the detail, Fig. 42, the rabble-blades are set at an angle to their line of travel. Nearly touching the hearth they pass through the ore, stirring it and moving it slightly forward in pushing it aside. The blades of the opposite rabble-arm incline in the opposite direction and stir the ridges thus formed. Thus every minute fresh surface is exposed to the action of the fire. An objection has been urged against this, as against all the mechanically stirred roasters (except the Edwards), that a part of the imperfectly roasted ore, adhering to the blades, creeps forward and mixes with the advanced portions of the charge, raising the percentage of sulphur in a way that need never occur in hand-roasting. Air from a fan-blower is forced into the central hollow column, thence out through the rabble-arms, thus cooling them, finally through nipples screwed into the underside of the arm between the blades, as shown in Fig. 42. In addition to this forced air from the fan, air enters through openings at the sides to oxidize the ore.

The fire-boxes, one of which is well shown in Fig. 41, are sup-

plied by air from the fan-blower under a slight pressure. By means of the under-grate blast the flame is caused to enter the furnace under a slight pressure, and thus oppose the inward draft of air through the side-doors. Suction increases as we approach the exit-flue, as indeed it must in order to take away the products of combustion. The fire-box is furnished with a step-grate suitable for burning slack coal. The ash-pit is closed by tight sheet-iron doors, so that the under-grate blast can be sustained. Occasionally these are opened so that the firemen can clean the grate. The ashes and clinkers are dislodged from between the step-grates, falling into the

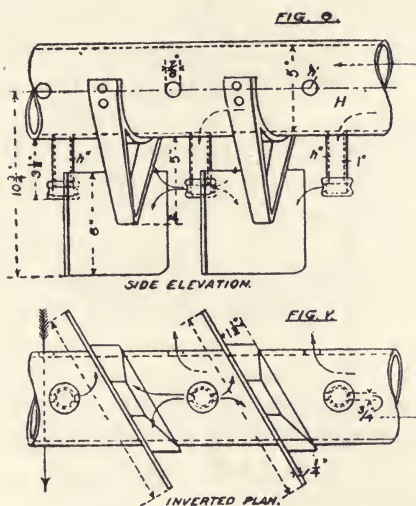

Fig. 42. DETAIL OF RABBLES.

ash-pit and being thence removed. The fire-box is supplied with coal by means of a hopper kept constantly full. To prevent an intense action of the heat where the flame would naturally strike the charge, a curtain-arch, lower, and having less curvature, as seen in Fig. 41, deflects and distributes the flame. There are three fire-boxes, all of which are upon the upper hearth; and the movement of the flame is in a direction contrary to that of the rabblers and the ore. The flame from the fire-box nearest the feed moving toward the outlet-flue heats the ore and sets it afire. The second and third fire-boxes raise temperature of the ore to the full heat; but the final action on the lower hearth is performed by the heat from the oxidation of the ore. The outlet-flue leads from the roof of the upper hearth, down the side of the furnace, to the dust-chamber below. An under-

ground-flue from the dust-chamber leads to the chimney. The hearths are bound by heavy bands. The upper hearth and the mechanism of the furnaces are sustained by the I-beam construction that serves also to provide for the slit through the inner wall of the hearth through which the rabble-arms must enter. The slit is covered by a sheet-metal band, which is attached to and revolves with the rabble-arms. The question might be asked, whether the flame from the third fire-box would not go directly to the outlet-flue instead of following round the hearth. To prevent this, the upper hearth is broken or interrupted for a space of 5 feet along the hearth, the rabbles being visible for inspection as they pass through this open section. The ends of the hearth are closed by swinging sheet-iron doors, like those of the Wethey furnace. As the rabble enters the open space the doors are lifted by the rabble-arm, and drop by gravity when it passes on. Though complicated in design, this is a furnace that has worked well in practice. It is 33 ft. interior diameter and has a 6 ft. hearth, this giving for the hearths an area of 1020 sq. ft. Its daily capacity is 35 tons of ore of 35% sulphur, which it roasts to 6 to 7% sulphur with a consumption of 9.1% fuel. The labor needed is but little more for a double-deck furnace than for the single one, while the fuel-cost per ton of ore is reduced one-half. Thus a single-deck furnace consumes 18% of fuel. More flue-dust is made in the double-deck furnace. To operate the two-deck furnace requires 3 hp., and the cost of roasting is 98c. per ton. Such a roaster costs \$8000 installed. In a multiple, or six-deck furnace, the fuel has been reduced to 1.4% of the ore tonnage, but the flue-dust is increased to 4 per cent.

The McDougall roasting-furnace.—There are several kinds of furnaces of this type. Among these are the Herreshoff, the Wedge, and the Evans-Klepetko. The latter, as manufactured by the Allis-Chalmers Co., is shown in sectional elevation in Fig. 43. It is a vertical, cylindrical furnace, 16 ft. diam., with six arched hearths, over which travel rabbles which stir and move the ore gradually toward the central drop-opening through the floor of each hearth, situated alternately at the center and at the periphery. A central shaft is provided, carrying six radial rabble-arms (three of these are hidden by the shaft in the illustration), provided with rabble-blades set at an angle on the arm as shown in Fig. 42.

The rabble-blades on the even-numbered hearths are so set as to push the ore toward the periphery; the odd-numbered ones toward the center. The ore, fed continuously into the furnace from a cylindrical hopper shown above and at the right, Fig. 43, drops upon the

upper hearth near its outer edge. The rabble-blades of that hearth stir and move the ore gradually toward the central drop-opening where it falls to hearth No. 2. The rabbles of this hearth again stir and move it to the outer drop-openings, through which it falls to hearth No. 3. The ore advances by this means until it reaches the lower hearth, where an opening at the periphery gives it exit to a

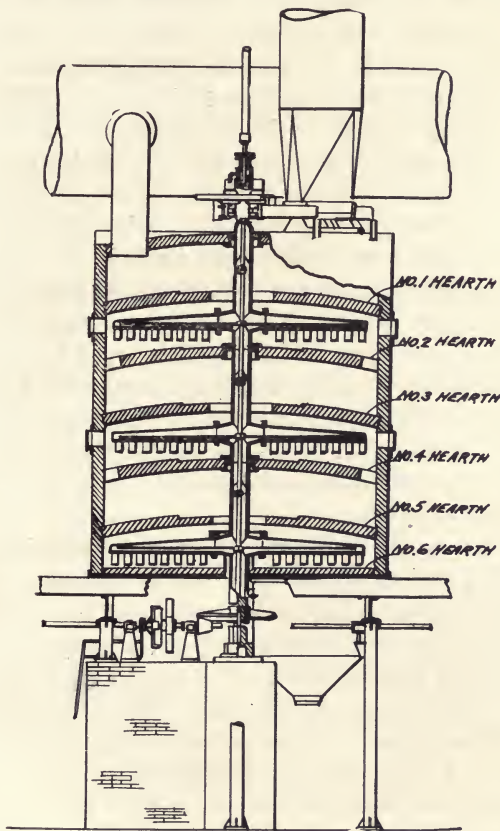

Fig. 43. McDOUGALL ROASTING FURNACE (ELEVATION).

receiving-hopper, shown beneath the hearth, from which it is drawn into a car as is required.

A high-sulphide ore roasts by its own heat when the furnace is in full operation. The ore fills the hearth to the level of the blades, and is spread out evenly by them. On the upper hearth, as the ore moves toward the central opening, it becomes dry and hot, and when dropped upon hearth No. 2, begins roasting. On hearth No. 3, the

ore roasts freely emitting sparks and forming sulphates. On hearth No. 4 no sparks are seen, and the ore has attained its highest temperature. On hearth No. 5 the ore looks less bright; and on No. 6, especially at the discharge, it has become cooler.

The air for oxidation is admitted by side-doors, mostly those of the lower hearths. The gas, and dust, passing up through the drop-openings, are drawn through the horizontal main flue. In starting, the furnace is heated to the kindling temperature of the ore which, if rich in sulphur, burns by its own heat, without the aid of fuel. If the sulphur content is low, additional heat is supplied by one or more external fire-places, near the bottom of the furnace.

To protect the rabble-arms from the intense heat they, and likewise the central shaft, are water-cooled. The cooling-water is forced down the 9-in. hollow, central shaft in a 3-in. pipe to a point near the bottom, and out to the ends of the arms in 1-in. pipes. It then returns up the annular space between the 3-in. pipe and the hollow shaft, and discharges at the top through two spouts into a launder. The furnace is $18\frac{1}{4}$ ft. high by 16 ft. diam., and has a total hearth-area of nearly 1000 sq. ft. The structure is supported on columns to give room below for the hopper and the car into which the roasted ore is discharged. The shell made of $\frac{3}{8}$ -in. plate-steel, is lined with 9 in. of brick-work. The rabble-arms consume $1\frac{1}{2}$ to 2 hp., and make one revolution in $1\frac{1}{4}$ minutes.

A furnace treats, in 24 hours, 40 tons of sulphide ore of 35% sulphur, reducing it to 7 per cent. About 4% flue-dust is made; and the ore itself contains more ferric oxide, and is lighter and more porous than if treated in a hand-reverberatory roaster. The cost of roasting such ore is approximately 35c. per ton, which is the lowest figure thus far known for any furnace. The compact form of the furnace reduces radiation to a minimum and enables roasting with little or no fuel. Taking capacity into consideration, the furnace is one of moderate price, and one that costs little to keep in repair.

Of the two revolving-hearth furnaces the Holthoff and the Raymond, the latter has some popularity for the preliminary roasting of ores for lime or pot-roasting, the powdered ore being showered down a vertical shaft or tower and coming in contact with an upward flame from a fire-box. An objection to its use is the flue-dust that is made.

21. ROASTING OF MATTE.

Copper-bearing matte is not difficult to roast, but must be crushed at least to 4-mesh size.

The term 'roasting' is applied also to a method of treating copper matte in a reverberatory furnace in large pieces, upon which an oxidizing flame is allowed to play. Such masses slowly melt and are acted on by the air, whereby a part of the material becomes oxidized or roasted sufficiently for the next operation. As compared with ordinary roasting this is slow, and the method is one but little used. Lead-bearing matte from the silver-lead blast-furnace, to be roasted in a reverberatory furnace of the kind shown in Fig. 32, needs a different treatment from that given to ore. This kind of matte contains but 20% sulphur, and does not take fire like pyrite ore, but must have a high finishing heat to expel the sulphur. Such matte is considered well roasted when it contains 4% sulphur. Ores low in lead can easily be roasted to 2 to 3% sulphur, while galena, when roasted, still contains 5 to 6% when drawn from the furnace. Like matte, galena starts burning slowly, and must be roasted slowly, for rapid heating at once causes it to sinter and thus stops further roasting. Typical leady matte contains metals and sulphur as follows:

	Raw, low-grade.	Roasted, low-grade.	Raw, shipping.
	Per cent.	Per cent.	Per cent.
Pb	10.66	10.49	9.06
Cu	4.62	4.12	42.30
Fe	53.11	52.41	20.00
S	26.87	6.13	17.89
	95.26	73.15	89.25

The roasted, low-grade matte tabulated above contains 23% oxygen. This explains why it does not lose weight in roasting. Pyrite ores of 20 to 30% sulphur, on the contrary, easily lose 15% in weight.

22. LOSSES IN ROASTING.

Such loss depends upon the extreme to which the roasting is carried as well as upon the nature of the ore. When ore is so roasted that it is not sintered at the final high temperature, the lead lost averages 2.5% but no loss of silver occurs. When the temperature is carried higher, and the ore is agglomerated, the loss is slightly higher. When fused it may reach 15 to 20% of the lead and 2 to 5% of the silver. Of the gold little is lost in oxidizing roasting.

23. CAPACITY OF FURNACES AND COST OF ROASTING.

These depend upon the surface exposed to the oxidizing influ-

ences and upon the quantity of sulphur contained in the ore. Silicious ore, containing $\frac{1}{2}$ to $3\frac{1}{2}\%$ sulphur, requires 13 to 15 sq. ft. of hearth-area per ton ore roasted per 24 hours. Matte containing 20 to 25% sulphur, when it is required to reduce the sulphur content to 4%, needs 45 sq. ft. hearth-area; copper sulphide ore, roasted to 7% in preparation for smelting, requires 33 to 35 sq. ft. For roasting iron-sulphide concentrate, which carries 35 to 45% sulphur, down to 3 to 10% sulphur, 55 to 60 sq. ft. hearth-area is needed.

Ore-roasting in heaps, at Jerome, Arizona, costs 80c. per ton, including general expense. Ore-roasting in stalls costs 50c. per ton. For reverberatory roasting, in long, hand-rabbed furnaces the lowest price attainable on copper ores was \$1.50, with an average of \$1.81 per ton. For roasting lead-bearing ores, \$1.75 is a moderate cost, and from this the cost, when all items are included, may rise to \$2.25 per ton. The Allen-O'Harra automatic furnace, having two straight hearths each 94 by 9 ft., and resembling the Wethey furnace, roasts 45 to 50 tons daily at a cost of 78c. per ton. The Wethey furnace, of the type having four hearths, each 65 by 10 ft., the roasting proceeding on all the hearths, roasts 90 tons daily to 5 to 6% sulphur, at a cost of 98c. per ton. The 16-ft. McDougall furnace (Herreshoff type), having five hearths, $14\frac{1}{2}$ ft. diam., and a total area of 830 sq. ft., roasts 33 to 35 tons daily to 7% sulphur at a cost of 50c. per ton. The Bruckner roasting cylinder, $8\frac{1}{2}$ ft. diam. by 22 ft. long, takes a charge of 20 tons (10 tons daily), and in 48 hours roasts it to 4% sulphur at a cost of 80c. per ton.

It will be noticed that the low cost of roasting in some of these furnaces is due to their needing no fuel after coming into full operation. To obtain this effect such furnaces have several hearths, and are compact. On account of this compactness they lose but little heat by radiation.

24. BLAST OR POT-ROASTING OF ORES.

Both lead and copper ores are treated by blast or pot-roasting, though the method was at first intended for lead-bearing ores, especially for galena. We have already mentioned the difficulty of roasting galena by the old method, in the reverberatory furnace; but by pot-roasting, it can be so treated as to remove most of its sulphur, with less loss by volatilization.

Treatment of galena.—By the Huntington-Heberlein process, called also the 'H and H process', the galena-bearing ore is given an incomplete, rather rapid roast, to reduce the amount of sulphur to 12 to 14%. The product from the roaster is mixed with a certain

proportion of limestone and silicious ore, wet down, and charged into a hemispherical cast-iron pot $8\frac{1}{2}$ ft. diam. by 4 ft. deep, having a capacity of 8 to 10 tons. Within the pot, and forming a false-bottom, is placed a circular arched plate perforated with $\frac{3}{8}$ -in. holes to admit air to the charge under pressure. Upon the false-bottom is scattered a wheelbarrow-load of ashes, then a carload (one ton) of hot ore from the roaster. On this is dumped 8 tons of wet charge. Air, under the pressure of a few ounces, is admitted beneath the false-bottom, and coming up through the hot ore, it produces a burning-temperature and starts the combustion of the charge. The heat gradually ascending to the top, the charge becomes red-hot, and SO_2 and SO_3 escape. At the end of the roasting, which lasts sometimes 16 hours, desulphurization is complete and there remains only 3 to 5% sulphur if the charge is properly burned. The pot is now inverted to discharge the contents, and this falls out in an agglomerated, red-hot mass. It is broken to a size suited to subsequent treatment in the blast-furnace.

There are three patented variations of this treatment of galena ores. In the first, the Huntington-Heberlein process (above described), the ore is mixed with limestone, partly roasted, wet down, charged into the pots, and blown, to the point of agglomeration. In the second, the Savelsburg process, the ore is mixed with limestone and charged directly into the pot or 'converter', the preliminary roasting being omitted. In the third, the Carmichael-Bradford process, the ore is mixed with gypsum and charged into the pot without preliminary roasting.

Treatment of copper sulphides.—This treatment, like the Huntington-Heberlein, consists in blowing the partly-roasted ore or matte in pots, but in this case no lime is used. The charge is first moistened so that it easily coheres. The minimum quantity of water to procure the best result is 3 to 4% for the low-grade matte, 4 to 6% for high-grade matte, and 6 to 9% for ore. In the case of ore it is found that, unless the water is in excess, ferric oxide is produced, and this, forming round the particles, prevents proper slagging; whereas with sufficient water, ferrous silicate is produced. The charge that works best consists of about one-third of pieces 1 to $1\frac{1}{4}$ in. diam., and two-thirds of fine concentrate. It should contain 15 to 35% SiO_2 and 15 to 25% sulphur.

In treating a charge the false-bottom is covered with lumps of roasted ore, after this, a small fire of chips and sawdust is started, and urged by a light blast. Ore is charged next, keeping it deeper at the sides, until the pot is half filled. Holes are punched into the

mass with a half-inch pointed rod, and through these appear sulphur vapor and sulphur dioxide, forced by the blast. In about an hour a ring of fire begins to show, the remainder of the charge is then put on, the pot is covered with a hood, and the blast gradually increased to 13 oz. per sq. in. After some hours the evolution of SO_2 slackens and the charge gradually becomes red-hot throughout. The blast is then stopped, the blast-pipe disconnected, and the converter inverted to discharge the contents. As arranged in some cases, the pot with its load is picked up by an overhead traveling-crane and dumped near a large crusher, and the roasted material crushed into lumps.

The time required to treat a charge varies from 8 to 12 hours. The product consists of a porous sintered mass of ferrous silicate containing shots of matte and free silica. It is well suited to blast-furnace smelting. A large quantity of the product in one instance contained 5.65% sulphur, while as little as 5% has been obtained in the treatment of ore. The process is particularly suited to the treatment of matte, to which 15 to 25% of silicious ore is added, to unite with the iron, forming ferrous silicate. In ores containing pyrite, the loosely held equivalent of sulphur is first driven off. The reactions should proceed rapidly so that a high temperature can be maintained to permit the formation of ferrous silicate, otherwise ferric oxide will be formed, diminishing the amount of active oxygen near it. Wherever this occurs, the temperature drops, and a patch of unsintered material is formed.

PART III. GOLD

PART III. GOLD.

25. GOLD ORES.

Gold occurs in nature, both in the native state and combined with tellurium.

Native gold occurs in vein-matter disseminated in grains or particles of various size, and it is found not only in quartz veins but in veins or lodes containing hematite, iron-pyrite, arsenical-pyrite, blende, and galena. In pyrite it occurs not only in the substance of the crystals but as films on the surface of these crystals. It is frequently accompanied by silver. When gold-bearing veins have become disintegrated and swept away into alluvial deposits, the particles of gold, where released, are found in the sand and gravel of the beds, the pebbles and boulders themselves (which have come from the country rock), being in general barren of gold. Gold occurring in this way is called alluvial gold, and is recovered by methods of hydraulic mining or dredging, which belong to mining engineering rather than to metallurgy. We shall here consider, therefore, the treatment of gold ore.

Gold tellurides.—In South Dakota, at Cripple Creek, Colorado, in Western Australia and elsewhere is to be found gold combined with tellurium as calaverite, AuTe_2 (containing 41.4% Au and 57.3% Te); also gold and silver combined with tellurium as sylvanite (AuAgTe_2), and as petzite (Ag_2Te , Au_2Te).

Classification on treatment basis.—Gold, regarded from the standpoint of milling and amalgamation, occurs in the following conditions:

(1) In ordinary amalgamable form, generally called 'free-milling'.

(2) In some form of intimate physical admixture, with other minerals, or in chemical combination with other elements.

(3) As rusty gold, sometimes metallic in appearance and of usual golden color, but often brown and lusterless. In this supposed allotropic form, it resists the action of mercury in the process of amalgamation.

26. STAMP-MILL AMALGAMATION.

This consists in crushing the gold-bearing ore, generally in a stamp-mill, to a size of 20-mesh, or finer (using 6 to 8 tons of water to one ton of ore), and running the ore-pulp over plates $4\frac{1}{2}$ ft. wide by 6 ft. long to which the gold adheres by amalgamating with the mercury with which the plate is coated. Occasionally the battery is stopped for a short time, and the gold-bearing amalgam is scraped from the plate and treated to obtain the gold. This process is called 'outside amalgamation'. Sometimes amalgamated plates are placed inside the mortar, and the particles of gold contained in the ore are driven against the plates by the movement of the pulp and adhere. The gold is recovered in the same way as on the outside plates. Some of the gold particles and mercury fall into the crevices between the dies, at the bottom of the mortar. This gold is recovered at the time of the monthly clean-up. From time to time a little mercury is placed in the mortar (about 1.5 oz. per ounce of gold in the ore), as the crushing proceeds.

The tailing, or residue after obtaining the gold, may be run to waste. If, however, ore contains pyrite, or other heavy sulphide minerals within which a part of the gold is locked, only a part of the gold can be recovered by amalgamation. Pyrite, being heavy, can be caught on concentrating tables, and the concentrate so recovered can be sent away to be smelted or be treated by leaching methods. At Treadwell Island, Alaska, only half the gold in the ore is obtained by amalgamation, and the concentrate, $2\frac{1}{2}\%$ of the weight of the ore, carries most of the remainder. The tailing from the concentrating tables commonly contains a small amount of gold.

The mechanical operation of pulverizing the ore to a fineness such as to liberate the gold particles from the enclosing gangue consists first in coarse-crushing the ore in a Blake type crusher (See Fig. 22), which discharges into an inclined-bottom bin, and withdrawing it thence to be crushed in a stamp-battery.

The battery.—Fig. 44 is a perspective view, Fig. 45 a side elevation, and Fig. 46 a front elevation of a 10-stamp battery such as is used in gold milling. Fig. 45 is a good example of a dimensional drawing.

Referring to Fig. 44, the parts will be found designated as follows: *A*, mortar-block; *B*, mud-sills; *C*, cross-sills; *D*, side-posts; *E*, platform; *F*, *G*, buck-staves; *H*, lower guide-timbers; *I*, upper guide-timbers; *J*, mortars; *K*, screen; *L*, die; *M*, shoe; *N*, boss or head; *O*, stem; *P*, tappet; *R*, cam-shaft; *S*, collars; *T*, cam-shaft boxes; *U*,

cams; *V*, cam-shaft pulley; *W*, line-shaft; *X*, tightening-pulley; *Y*, water-pipes; *Z*, automatic feeder. On two of the cross-sills *C*, is to be seen the frame that supports the apron-plate.

The mortar-blocks, *A,A*, are made of timbers set on end, as shown also in Fig. 45 and 46. They are set in a pit that extends down to

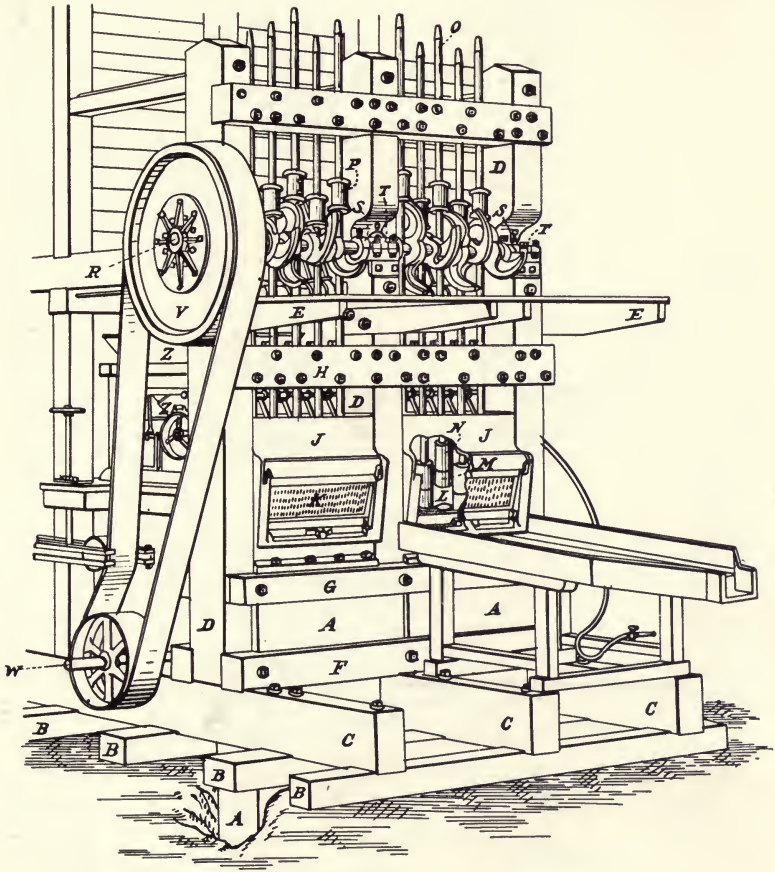

Fig. 44. PERSPECTIVE VIEW OF TEN-STAMP BATTERY.

solid rock or to a concrete foundation, and upon the solidity depends the durability of the battery. They are bolted together horizontally, and are held in position by a tamping of sand, rock, or concrete, completely filling the pit around them. Instead of wooden mortar-blocks, concrete ones have, of late, come successfully into use. These are more solid, more durable, and cheaper.

The mortar *J* is firmly held to the mortar-blocks by long bolts

(See Fig. 46), three thicknesses of blanket of a piece of rubber-sheeting being interposed to give an even bearing.

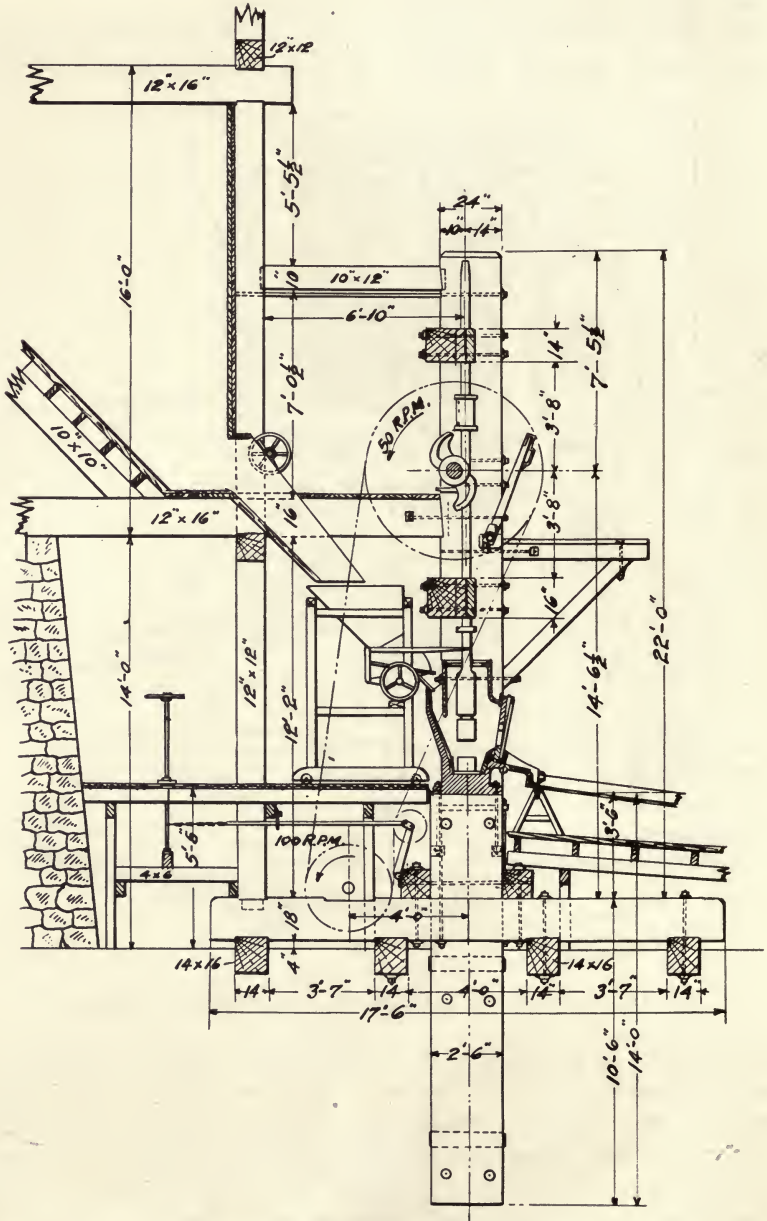

Fig. 45. SIDE ELEVATION OF TEN-STAMP BATTERY.

The stamp-frames consisting of the mud-sills *B*, the cross-sills *C*, the side-posts *D*, the buck-staves *F* and *G*, and the guide-timbers *H* and *I* are of the dimensions shown in Fig. 45 and 46. The mud-sills, supporting the cross-sills *C*, run the length of the mill, under all the batteries, and carry the line-shaft *W*. A tightening pulley just above

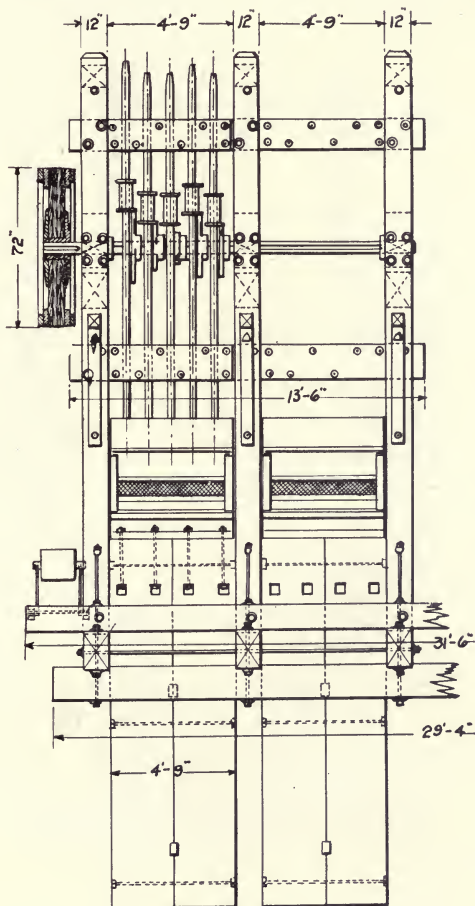

Fig. 46. FRONT ELEVATION OF TEN-STAMP BATTERY.

the lower pulley, serves to tighten the belt and set the battery in motion. To the guide-timbers *H* and *I* are bolted the guides, often made of two planks each 4 by 14 in. bored vertically with 3-in. holes for the wrought-iron or steel stems. Otherwise cast-iron individual guides are employed.

A mortar, as seen in Fig. 47 and 48, is a cast-iron box having at

one side a feed-opening through which the ore enters, screen-openings at one or both sides for the screens, through which the stamped ore or pulp discharges, a heavy base on which rests the die, and sides enclosing the whole, the mortar being a single heavy casting weighing 2 to 3 tons. Fig. 47 is a mortar of the single-discharge type, used in gold-milling; and Fig. 48 a double-discharge mortar, used in sil-

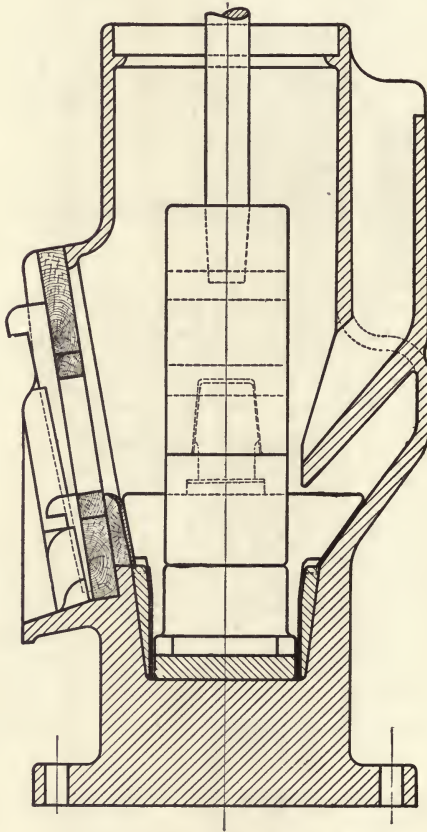

Fig. 47. SINGLE-DISCHARGE MORTAR.

ver milling. With the single-discharge mortar the output is less, and the pulp is retained a longer time in the mortar. In consequence it is more finely ground, and more intimately brought in contact with the inside plates when used. The double-discharge mortar on the other hand on account of the greater total opening, discharges freely, and pulverizes more ore. It is not a mortar intended for amalgamation, but for crushing only. Upon either mortar will be noticed a

deflecting-lip at the bottom of the feed-opening. This is provided to discharge the ore nearer the center of the mortar. Beneath it, and protected from the wear of the entering ore, an inside plate is sometimes placed.

Screen-openings are provided at the front, and in the double-discharge mortar also at the back of the mortar. The screen *K*, Fig. 44.

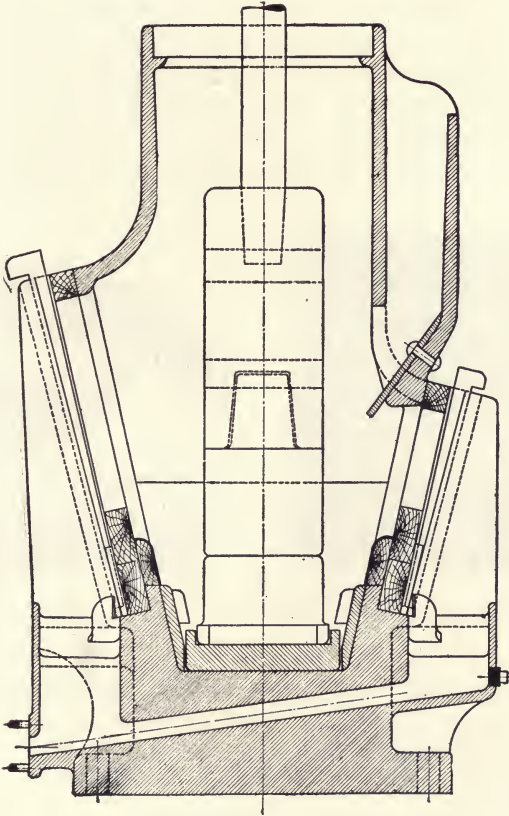

Fig. 48. DOUBLE-DISCHARGE MORTAR.

tacked to a wooden frame, is made either of wire-cloth or punched-plate. Of the two kinds, the punched-plate screen has the advantage in strength and first cost. The wire-cloth, on the other hand, if of copper or brass, is durable and gives a greater discharge area. Thus in the case of No. 7 punched-plate, Fig. 49, we have effective in discharge openings but 10% of the total area; while in the case of the wire-screen 27% is open and in consequence, there is less sliming

or excessive powdering of the ore because of its prompt escape from the mortar.

To increase the height of discharge, when the pulp is to be retained a longer time in the battery for finer crushing a wooden chuck-block is placed in the discharge-opening beneath the screen-frame. The height of discharge may be defined as the vertical distance from the top of the die to the bottom of the opening of the screen-frame. Where inside amalgamation is practised, an inside amalgamated plate covering the chuck-block is used in addition to other plates, and on these plates as much of the gold as possible is collected. Referring to Fig. 47 and 48, we see a foot-plate that covers the bottom of the mortar, upon which rest the five cylindrical dies 8 to 9 in. diam. by 7 in. high when new. Resting on the die we

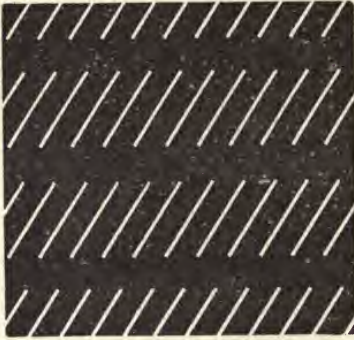

Fig. 49. PUNCHED SCREEN.

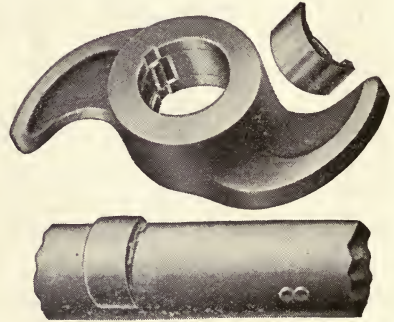

Fig. 50. CANDA CAM.

notice the stamp-shoe fitting into the head, which in turn is secured to the stamp-stem. The shank of the shoe is made a little smaller than the corresponding recess in the head, and in inserting it, wooden shims are placed around the shank, and the stamp is dropped upon it, thus wedging the shoe into the head. Dies and shoes are made of chilled cast-iron, manganese steel, or chrome-steel, chilled cast-iron being common. The wear upon shoes and dies amounts to $\frac{1}{4}$ to $1\frac{1}{4}$ lb. per ton of ore crushed, depending upon the toughness of the ore. On an average these parts last three months. In the case of chilled cast-iron, $\frac{3}{4}$ lb. at 6c. per lb. or 4.5c. per ton of ore treated is an average cost for wear.

The tappets *P*, Fig. 44, of cast-iron are keyed to the stems. The stamps are lifted 8 to 16 in. by the cams *H*, and are adjustable to give them the drop desired. At the same time, they cause partial

rotation of the stem on its axis and insure an even wear of the shoe and die. As the toe of the cam passes on, the whole 'stamp' (shoe, head, stem, and tappet), drops with the impact of 1000 lb., falling freely upon the ore in the mortar. The replacing of a cam of the ordinary type, requiring the removal of the key that holds it, is a tedious operation, and to overcome this, a self-tightening cam like the Canda, Fig. 50, has been devised. This consists of a curved tapering key that fits an eccentric recess in the cam. Into the shaft is set a slightly projecting pin which engages the key in a groove or recess so that when cam and key are set upon the shaft over the pin and turned, the key wedges and tightens the cam to the shaft. The cams are set on the cam-shaft at various angles so that the stamps drop at regular intervals and in a pre-determined order. The stamps being numbered consecutively from left to right, in a 5-stamp battery, a favorite order of drop is No. 1, 4, 2, 5, 3.

The cam-shaft is carried by boxes secured to the side-posts, and is driven by a large pulley made of wood in preference to iron, in order to withstand the shock of operation. When it is desired to stop the battery, the stamps are 'hung-up' by inserting under the tappets the 'fingers', one of which is seen in the elevation, Fig. 45.

Ore is fed to the battery automatically by a feeder marked Z, in Fig. 44 and 45, that takes its supply from the sloping-bottom storage-bins above. As seen in Fig. 47 and 48, there is a ledge or lip on the mortar over which the pulp flows to the apron-plate. In the double-discharge mortar, the pulp-flow at the back of the mortar joins that at the front by passing through a hole or passage in the base of the mortar.

27. OPERATION OF THE STAMP-BATTERY.

From the storage-bin, indicated behind the battery in Fig. 44, and shown in section in Fig. 45, the ore, crushed to $1\frac{1}{4}$ -in. size, passes a chute to the hopper of the automatic-feeder. A feeder of the Challenge type is shown in Fig. 51.

At each drop of one of the stamps, a collar on the stem strikes the end of the projecting horizontal lever, and this lever actuates the feed-plate, revolving it slowly against a fixed scraper, and causing ore to fall into the feed-opening of the mortar. As the ore accumulates under the shoes, the stroke shortens, and the thrust of the horizontal lever being less the feed corresponding is lessened. As the ore supply lessens the stroke lengthens. Thus the action, according to the needs of the battery, is automatic. Water is introduced through a pipe at the feed-opening, and mixing with the pulverized ore,

splashes out through the screen at each fall of the stamps. The feed is regulated so as to cause the stamp to strike with a sharp, hard blow, but with little of the rebound that would occur with too thin a layer of ore.

Mercury fed to the battery.—This varies from 1 to 6 oz. per ounce of gold caught, the average being 1.5 oz. Added a little at a time inside the mortar, it works out in part upon the apron-plates. As to the

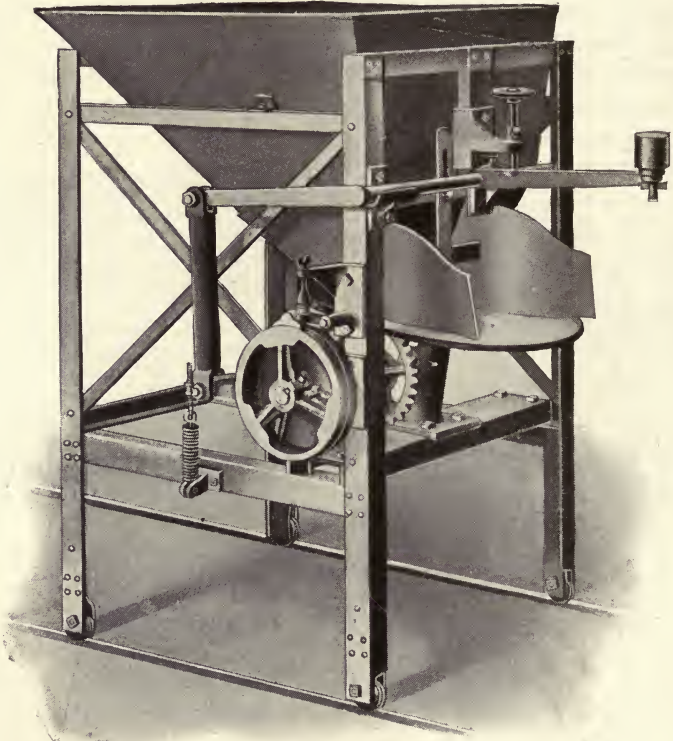

Fig. 51. AUTOMATIC FEEDER.

amount to use, a safe guide is the appearance of the plates. If they are hard the indication is insufficient mercury; if mercury is distinctly visible on them, either in patches or in streaks, too much is being added. The mercury should be free from base metals that cause it to 'sicken', or break into coated globules. Such globules refuse either to coalesce or adhere to the amalgamated surface, and are swept away with the pulp. Mercury is best that already contains gold and silver.

Dressing the plates.—The outside or apron-plates are dressed three or four times daily, the operation taking about 15 minutes. To do this, the feeding is stopped to permit the ore to work out of the mortar, the stamps are 'hung-up', and the apron-plate washed clean with a stream of water. A rubber-edged scraper, resembling, but heavier than a window-cleaner, is used to scrape the plate. The amalgam, perhaps half a pint in quantity, is scraped together with this, gathered up, and placed in an enameled cup. If the surface is too hard for the scraper, the amalgam is softened by sprinkling a little mercury upon it. Dressing being completed, the stamps are started, and feeding is resumed.

Plates are liable to become tarnished with salts of copper that form a coating like verdigris upon the surface. Since the tarnished

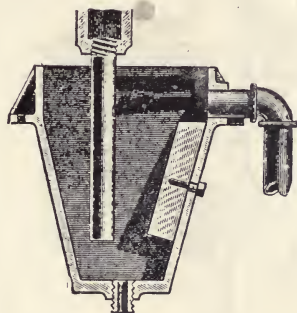

Fig. 52. MERCURY TRAP.

spot collects no gold, the stains must be removed. To do this a solution of sal-ammoniac is applied to the stained parts with a scrubbing brush when the battery is stopped. In a few minutes this chemical is washed off, and potassium cyanide and then mercury are rubbed on, and the plate immediately washed clean. Apron-plates have a grade of 0.5 to 1.75 in. per foot, ore containing sulphides requiring the steepest grade. When the pulp is flowing over the plate in a proper manner it travels down in the form of series of ripples or waves, bringing the particles of gold in contact with it.

To save escaping particles of amalgam or globules of mercury that fail to adhere to the plate, a mercury trap, Fig. 52, is provided. This is especially important where no concentration of the tailing is attempted. In shape it is an inverted frustum of a pyramid. The pulp enters by the vertical pipe, and escapes over the wooden block shown belted to the side of the trap. The pulp overflows through the pipe at the side. Some heavy sulphides accumulate in this, but

the amalgam works down into the bottom. Occasionally the accumulation at the bottom of the trap is emptied through the plug-hole in the bottom, and is panned to recover the amalgam.

The clean-up.—In operating a 40-stamp mill, it is customary to remove the entire accumulation of amalgam from the mortar every

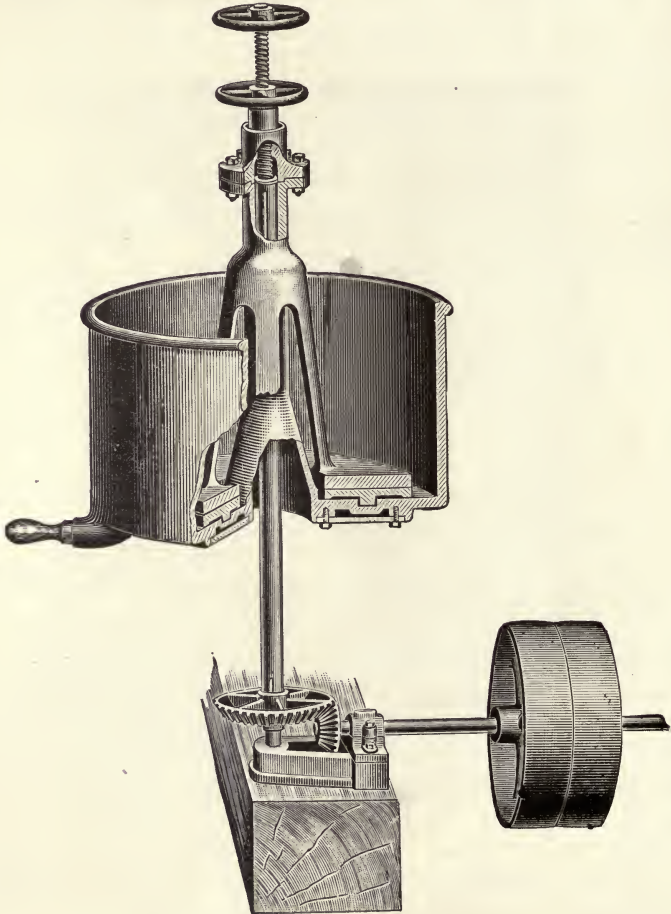

Fig. 53. CLEAN-UP PAN.

two to four weeks, and to thoroughly dress and scrape the plates. To do this, two batteries (10 stamps), at a time are hung up. The screens, inside plates, and dies, are taken out, and the contents of the mortar, perhaps two or three bucketfuls, is carefully scraped out and fed to the next batteries. The plates are then dressed, the dies and

screens returned to place, and the two batteries again started. The next two are taken in the same way, and so on. Finally the last batteries are hung up, the contents removed and put into a clean-up pan, Fig. 53, with the amalgam from the well-scraped plates. Three men can 'clean up' a 40-stamp mill in five to seven hours.

The clean-up pan, Fig. 53, 3 ft. diam. by 3 ft. deep, making 12 to 15 r.p.m., is used for grinding the sand, pyrite, fragments of iron, and other substances, collected with the amalgam in the battery clean-up. The charge, of 300 lb., mixed with water, partly fills the pan. It is ground to a fine mud in 3 to 4 hours, during which time 50 lb. mercury is added, and the mixing continued a few hours longer. The pulp is then diluted with water, the muddy portion decanted by taking out a plug that is a little above the bottom. The residual mercury and amalgam, with some of the mud, is withdrawn through the lowest plug-hole, panned, treated in an enameled-ware bowl with nitric acid, and well washed until clean. The residual mercury and amalgam is strained through chamois skin, or through canvas, to remove the excess of mercury. Gold amalgam, when well squeezed through cloth, contains 35 to 45% gold. The mercury that has been removed by filtration still retains 0.5 per cent.

Retorting.—In the smaller gold-mills, amalgam is retorted in a pot-shaped retort, Fig. 54. In larger mills a horizontal cylindrical retort is used, though the latter is chiefly for silver-mills where a large quantity of amalgam is made. The retort, Fig. 54, is filled two-thirds full of amalgam, placed in a wind-furnace and supported by perforated cast-iron thimble that rests on the grate-bars. The cover is luted and tightly clamped. A pipe through which the mercury vapor passes leads out from the cover and turns downward. The outer leg of the pipe is water-cooled and the end dips into a tub of water. A fire having been started on the grate-bars, the retort gradually heats until mercury vapor begins to come over. It condenses in drops in the cool pipe and collects in the tub below. When a distilling heat is obtained, the fire is checked and the retort kept at an even temperature for one or two hours, after which it is heated to redness to expel the last of the mercury.

The mercury, collected by condensation in the tub under water, is used again. This accounts for the small loss, which averages in California practice but 0.5 oz. per ton of ore treated. Mercury is lost by 'flouring' and by 'sickening'. The first of these losses is indicated by a white appearance, and is caused by excessive agitation in the air, which breaks it into globules or particles so fine as not again to unite or at least, not without great difficulty. Sickened

mercury is black, and owes its appearance to the presence of base metals, as already explained. The retorted residue, still containing 0.5 to 1% mercury, is porous, and consists of gold from 500 to 900 fine. It is melted in a plumbago crucible in a wind-furnace with soda and borax, and when it contains base metal, with a little nitre

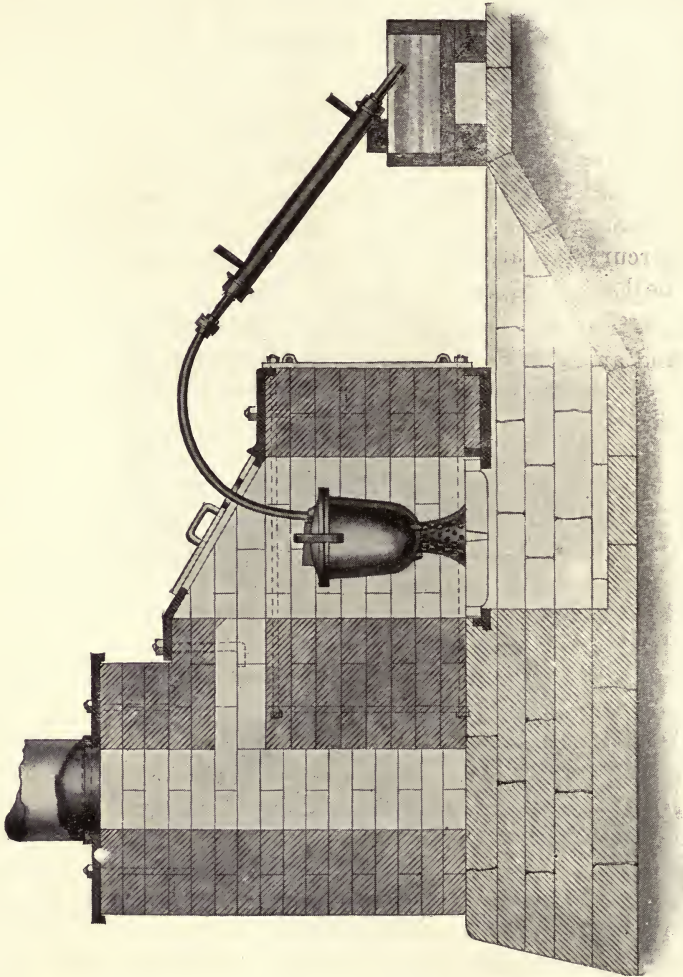

Fig. 54. GOLD RETORT.

which serves to toughen it. The melt is poured into an ingot mold; and the bar, cleaned from adhering slag, is shipped to the mint.

28. GENERAL ARRANGEMENT OF A GOLD MILL.

Fig. 55 is a plan, and Fig. 56 an elevation of a 20-stamp mill, where ore is amalgamated and the tailing concentrated.

The ore enters the mill on a high-level track in tram-cars and is dumped into a gyratory crusher and broken to 1 to 1¼-in. size. From the crusher it goes by a shoot to either of two storage-bins for the two batteries of 10 stamps each. The crushing is done during the 10-hour day-shift, and the bins are large enough to hold a day's supply. From these bins the ore discharges into automatic feeders (not shown), and from there, in constant supply to the stamp bat-

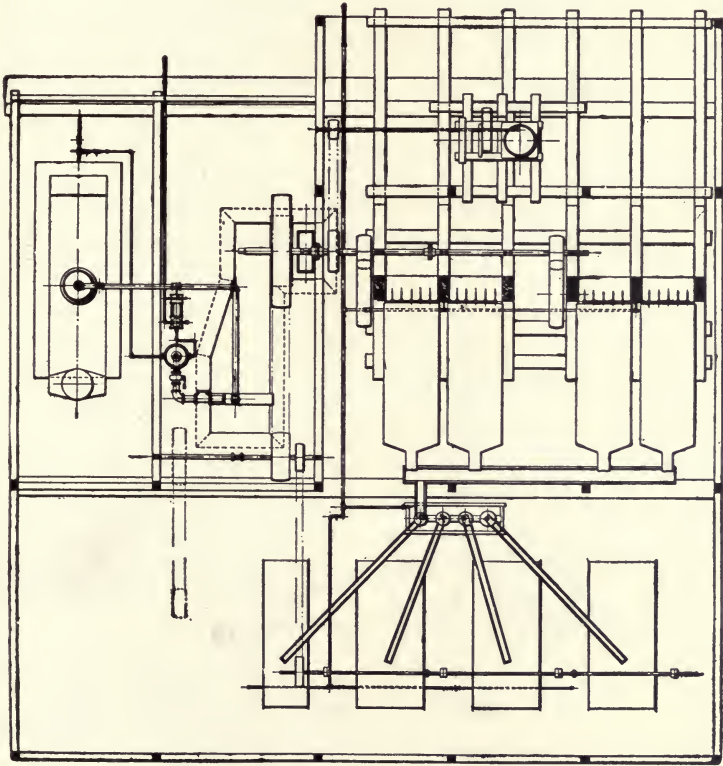

Fig. 55. PLAN OF TWENTY-STAMP MILL.

teries. The batteries are driven by a direct-coupled driving shaft supported upon the mud-sills of the batteries, as shown by *W*, Fig. 44. The pulp, splashing through the battery screens, flows over a set of short apron-plates. The tailing from the plates unites in a launder, and finally falls into a distributing box that commands the tables. A distribution is made here and one-fourth is supplied by a launder, to each vanner. The tailing from the vanners is wasted. The concentrate is collected, and shipped for smelting. The method

of driving the machines is indicated in Fig. 56. Above the battery runs an over-head track, carrying a trolley and heavy chain tackle, by means of which a stamp or any heavy part can be removed readily or replaced.

When ore contains heavy sulphides, such as pyrite, the tailing from the plates is concentrated on the Frue vanner, or the Wilfley concentrating-table. Thus a valuable product is obtained in a small bulk, and any escaping particles of amalgam are caught with the

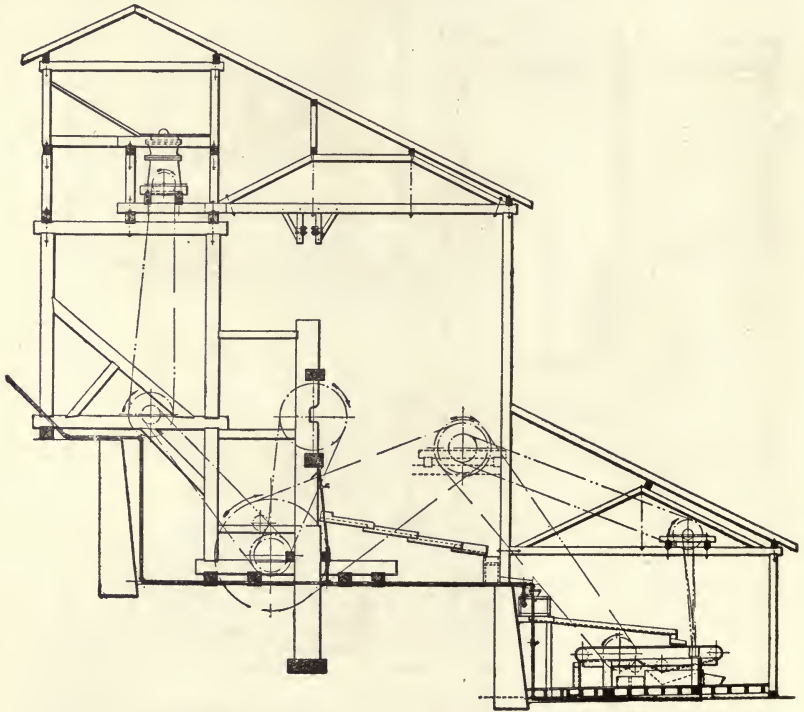

Fig. 56. ELEVATION OF TWENTY-STAMP MILL.

concentrate. When ore contains gold, both coarsely and finely disseminated, the usual method has been to recover the coarse gold by amalgamation, and treat the residue by cyanidation to extract the gold not recovered by amalgamation. Another practice, dispensing with amalgamation, has been to crush with stamps, separate the slimed material, and re-crush the coarser portion (the sand), thereby finely grinding the auriferous particles so that they may be cyanided in a reasonable time, not possible with ore consisting of coarse auriferous particles.

29. CALIFORNIA AND COLORADO PRACTICE IN GOLD-MILLING.

For free-milling ores, where the gold is coarse, and where in consequence fine grinding is not needed to release the gold from its matrix, California practice, with rapid drop and low discharge is preferred, since in this way large tonnage is secured. On the other hand in Gilpin county, Colorado, the ore contains 10% gold-bearing pyrite in which the gold is finely disseminated. To release the gold, the ore must be longer retained within the mortar and finely crushed. While retained there the fine float-gold, set free, has time to come in contact with the inside amalgamating plates. These recover about 75% of the gold.

In California practice, the stamps weigh 900 to 1100 lb., drop 80 to 110 times per minute, and have a fall of 5 to 9 in. In Colorado practice the stamps, weighing 600 to 800 lb., drop only 25 to 30 times per minute, but through a height of 18 to 20 in. In general, the greater number of drops per minute the greater is the tonnage. To pulverize the ore finer and retain it in the battery a longer time for inside amalgamation, a high discharge is needed, and this is obtained by using a deeper chuck-block, bringing the height in the Colorado type of battery to 13 to 18 in., while in California practice it is but 5 in. The objection to a high discharge is that more of the ore is slimed and is difficult to concentrate, causing a high loss of gold-bearing pyrite in the tailing. In California practice 4 tons per head may be crushed; in the Colorado practice it is but 1 to 1.5 tons. We thus have the following practices for average ore:

	California.	Colorado.
Drops per minute	95	28
Height of drop (inches)	7	18
Height of discharge (inches)	5	15
Weight of stamps (pounds)	1000	700
Actual horse-power per stamp	2.02	1.07
Capacity in 24 hours (tons)	4	1.25

The theoretical horse-power of a single stamp is calculated by multiplying the weight in pounds by the distance lifted per minute, in feet, and dividing by 33,000. The actual horse-power may be computed as 1.2 times the theoretical. The harder and tougher the ore, the slower will be the crushing; while the softer, and more friable the ore and the coarser the product, the larger will be the tonnage.

30. COST OF GOLD-MILLING.

In South Africa, where amalgamation has been followed by cyanidation of the tailing, the cost of milling and amalgamation has been \$0.72 to \$1.20 per ton and \$0.96 to \$1.44 per ton additional for cyaniding. These costs are based upon an output of 4½ to 5 tons per stamp.

In California in 1896 at a 30-stamp mill there were crushed and concentrated 33,512 tons of ore at the following itemized cost per ton:

Shoes and dies	\$0.029
Screens	0.003
Mercury	0.007
Hardware, belting, and firewood	0.021
Water for power	0.095
Freight, cyanide, oil, and grease	0.006
Lumber	0.008
Miscellaneous	0.007
Assay and office supplies	0.008
Silver-plated plates	0.007
Water-pipes and connections	0.021
Hauling sulphides	0.020
Express on bullion	0.006
Taxes and insurance	0.010
Superintendence and labor	0.160
	\$0.408

A summary shows that of this cost, \$0.153 was for repairs, \$0.16 for labor, and \$0.095 for power.

At a certain 30-stamp mill in Idaho, the cost was \$0.41 per ton; at a 40-stamp mill in California, \$0.50, and at another \$0.49 per ton. At a 40-stamp gold-mill in Gilpin county, Colorado, the cost was \$0.84 and at another \$1.47 per ton. Oleott gives the cost of milling at several California mills as varying from \$0.20 to \$0.75 per ton, and in a Gilpin county, Colorado, mill \$0.95 per ton.

31. THE HYDROMETALLURGY OF GOLD.

At the present time there are two methods by which gold is dissolved from its ore by chemical solvents. In either process the first step is to obtain the gold in aqueous solution, then to precipitate it from the clear filtrate, and finally to get it in the form of a bar or ingot.

These two processes are: (1) The chlorination or Plattner process, by which the gold is obtained in solution as a chloride by the action of an aqueous solution of chlorine gas. (2) The cyanide or MacArthur-Forrest process in which the solution of the gold is effected by a weak cyanide solution, the dissolved gold then being present as potassium auro-cyanide. With certain refractory ores, the activity of the solution is greatly increased by the use of bromine or bromo-cyanogen in addition to the potassium cyanide.

Extraction of gold by means of a solvent in aqueous solution is also practised where gold cannot be completely extracted by amalgamation. This often is the case with pyrite ores; and extraction can be practised to advantage not only where amalgamation is unsuitable but where smelting is expensive.

Gold in ore occurs in particles of various sizes, both as grains readily seen, and in particles of microscopic size. When the particles are visible, or when the ore shows 'colors' upon panning, the gold is called coarse, and such particles generally can be recovered by amalgamation. Gold often occurs in finely disseminated, microscopic particles, not visible to the eye, and in films on the surface of pyrite crystals. If the ore can be ground so fine as to unlock the crystals, or if it is permeable to solutions, gold can be dissolved in aqueous solvents, such as chlorine or potassium cyanide. Advantage is taken of the solubility of the released gold particles, and leaching or percolation methods, in tanks or vats, are practised with this in view. The solution soaks through the ore, comes in contact with gold particles, and dissolves them, or by another process, the finely-ground ore or slime is agitated with the solution, and the pulp is filtered and washed in filter-presses. The clear filtrate, in any case, is treated by a suitable precipitant to obtain the gold in small bulk, and the precipitated gold is melted and cast in the form of a bar or ingot for sale.

There are thus three stages in any method of extracting gold by aqueous solvents: (1) The ore is finely ground, and when refractory roasted, to convert the gold into a soluble form, and render it accessible to the solution. (2) The gold is extracted from the ore by means of a dilute solvent, using a tank with a filter-bottom, or agitating the ore, pulverized to a thin pulp, using a filter-press for the separation of the solution. (3) The gold in the solution is precipitated (a), in chlorination by hydrogen sulphide or other precipitating agent or (b), in cyanidation by the use of zinc-shaving or dust. The precipitate is collected, dried, and melted into an ingot.

The cyanidation has proved a remarkably cheap and efficient

method of extraction, but it has limitations, not only in respect to the solubility of the gold, but because of the interference of compounds that sometimes are present, notably those of copper, that interfere with extraction in various ways. The process has the advantage over the chlorination method in that silver, as well as gold, can be extracted. Under favorable conditions the extraction is high, and modern methods have reduced the cost of treatment to a low figure.

Pyrite ore, exposed to the weather, becomes acid in reaction, and if treated by cyanide, decomposes and destroys the potassium cyanide. To correct this, ore is first treated by a wash of dilute caustic soda, or if acid, mixed with caustic lime in sufficient quantity to overcome acidity.

When ore is refractory and requires preliminary roasting, the cost of roasting adds much to the cost of treatment. In chlorination, roasting is always necessary, and in any case it improves the condition of the ore and makes it porous and permeable when leached or filter-pressed.

32. CHLORINATION OF GOLD ORES.

This consists in attacking the gold of the ore with chlorine to form the soluble gold chloride, and dissolving out the gold chloride in water.

The complete process consists of the following parts: (1) **Preparation**.—Crushing and roasting the ore. (2) **Extraction**.—Bringing gold into the form of gold chloride, which is soluble in water, and leaching this out, obtaining a clear filtrate that contains the gold chloride. (3) **Segregation**.—Precipitating the gold from the filtrate in metallic form, or as a sulphide and collecting and refining the precipitate to obtain the gold in the form of an ingot.

Ores suited to chlorination.—An ideal ore for chlorination is one in which the gold is present in a state of division, in which bases are absent that would be attacked by chlorine, and silver if present is in such a condition as not to coat the particles of gold with insoluble silver chloride. While the cyanide process is better for the treatment of low-grade ores, many refractory high-grade ores have given better results by chlorination.

Ores, in which the gangue consists of hydrated iron-oxide, are extremely difficult to amalgamate. Not only is the gold finely divided, but the ore is slimy and forms a coating on the amalgamating-plates. Such ores give satisfactory results by barrel-chlorination. Silver is not recovered by chlorination since it becomes an in-

soluble silver chloride. If, however, sufficient silver be present to pay the increased cost, salt may be used in roasting and the silver extracted by means of sodium hyposulphite. A recovery of 60% of the silver is possible in this way.

Below are analyses of ores that have been successfully treated by chlorination:

Fig. 57. TABLE OF GOLD ORES.

	(1)	(2)	(3)	(4)
	Cananea, Mexico.	Portland mine, Cripple Creek, Colo.	Delano mine, Eureka and Boulder county, Colo.	Idaho mines, Grass Valley, Cal.
Cu	0.10	0.85
Zn	0.78
Pb	0.78
Mn and Fe.....	3.40	4.15	6.00	40.65
S	0.80	2.49	2.20	32.80
SiO ₂	83.50	54.91	89.50	12.64
Al ₂ O ₃	3.20	17.80	0.19
MgO and CaO.....	2.40	0.25	5.83
Alkalis	12.00
Ag (oz. per ton).....	1.35	0.50	1.25	2.00
Au (oz. per ton).....	1.23	1.00	0.65	8.00

Roasting.—Oxidized ore at Mount Morgan, Western Australia, containing but a trace of sulphide, is crushed in Krupp ball-mills and quickly roasted (flash-roasted), in a cylindrical roaster like the White-Howell, Fig. 40, to dehydrate it and make it porous.

Ore, containing sulphur, arsenic, and antimony, is crushed to 10 to 30-mesh size, and is roasted to expel these elements, to oxidize the bases, to leave the gold in such form as to be attacked by chlorine, and to make the ore porous, accessible to chlorine, and more easily leached.

In attempting to chlorinate ore (1) of the table unroasted, the sulphur (0.8%), consumed chlorine, and an extraction of only 25% resulted. After dead-roasting, 98.4% of the gold was extracted.

Cripple Creek ore (2) containing 2 to 3.5% sulphur was roasted to 0.08 to 0.10%, then cooled, and chlorinated. The extraction of gold was 92 to 95% of the amount present. The loss of gold in roasting, due to volatilization and dusting, is commonly 3 per cent.

Ore (3) containing gold telluride, is broken by graded crushing (See Fig. 25), to 20-mesh size, and is roasted in a Pearce-turret roaster. (See Fig. 40 and 41). The ore, discharged from the furnace, passes to an automatic cooling-device, consisting of vertical tubes surrounded by water. The ore passes down the tubes, and is gradually removed in cooled condition at the bottom.

Ore (4) is a concentrate from gold-milling, containing much sulphide, and typical of California ore to which chlorination is applied.

The coarse gold has been removed, by milling and amalgamation, and the concentrate, generally 1.5 to 2% the weight of the ore milled, contains gold in fine particles. The concentrate is roasted generally in long-bedded reverberatory furnaces (Fig. 32), 60 ft. long, and 3 tons capacity per 24 hours. This ore contains copper, lead, lime, and magnesia, all of which consume chlorine, and form chlorides. To prevent this, it has been customary to add salt, to the extent of 0.75 to 1.5% of the charge, at or near the completion of the roast. If roasting has been thorough up to this time, copper is present as CuO , lead as PbSO_4 , lime as CaO , and magnesia as MgO .

Were the copper present at the end as CuSO_4 it would react with the salt forming a chloride of copper. The common salt also reacts upon the gold and forms gold chloride. Both these chlorides are volatile, and the CuCl , in volatilizing, promotes the volatilization of the gold. Professor S. B. Christy, who conducted muffle roasting-tests on pyrite mixed with 5% of salt, found at a dull-red heat, 12% of the gold, and at a cherry-red 21%, to be lost. The losses in silver were somewhat less, being 7% and 17% under these conditions. As long as sulphur is present it protects the gold from attack, but when sulphates have been formed, and are causing the abundant evolution of chlorine by reaction with the salt, the escaping gas carries gold chloride, the gold being unprotected by sulphur at the time of chloridization.

Lead sulphate similarly reacts with salt, forming lead chloride, which does not consume chlorine. When much lead is present, however, it is removed by leaching with hot water before treating with chlorine. Lime and magnesia are converted by the salt into chlorides, and in this form consume no chlorine. The process of roasting is therefore conducted as follows:

The ore is thoroughly roasted at a low-red heat. The temperature is then a bright-red (850°C .), to decompose copper sulphate. The salt is then added and thoroughly incorporated, and the temperature reduced to prevent volatilization of the gold. The quantity of salt to be added, the time needed for roasting, and the temperature compatible with the minimum loss of the gold, should be determined experimentally for each kind of ore.

33. EXTRACTION OF THE GOLD BY CHLORINATION.

There are two methods of chlorinating ore. These are (1) the vat, or Plattner process. (2) The barrel, or Theiss process. In the vat method the ore, after moistening, is charged into the vat and subjected to the action of chlorine gas conducted into it from a sepa-

rate vessel. No motive power is required, and, aside from the cost of the roasting-furnace, but small investment is involved in the plant. The process is suited to the treatment of a small daily supply of concentrate. In barrel chlorination, ore is charged into lead-lined steel barrels or cylinders, and there exposed to the action of chlorine generated from chemicals within the barrel itself. The barrel is rotated, bringing the gold intimately into contact with the chlorine, which acts powerfully upon the gold while in the nascent condition. Barrel chlorination requires a large initial investment in machinery and apparatus. It is, however, suited to a large tonnage, and is a less costly process and gives a high and rapid extraction.

34. THE VAT OR PLATTNER PROCESS OF CHLORINATION.

The ore, which as above stated, has been subjected to an oxidizing roast to free the gold and render the ore porous, is moistened and charged into a tank or vat 8 to 9 ft. diam. by 3 to 3.5 ft. deep.

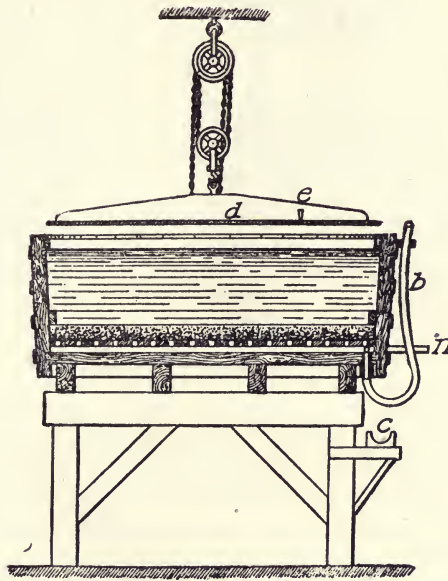

Fig. 58. CHLORINATION LEACHING VAT.

This vat, Fig. 58, has a false-bottom of perforated 1-in. boards supported on 1-in. strips above the bottom of the vat.

Upon the perforated bottom is spread a layer of quartz first in pieces the size of eggs, then smaller toward the top. Above this is a 2-in. layer of sand, and on this is laid a canvas filter-cloth or an open

grating of boards, to protect the filter and give a surface on which to shovel. Chlorine gas is admitted through the pipe *n*, and the solution is discharged through the hose *b*, into the launder *c*, which leads to the settling vats. When not in use the hose is turned upward in the position shown.

The 4-ton charge of ore is carefully moistened with a suitable amount of water (6%). If too dry, the gold is not well acted upon by the chlorine; if too wet, the gas does not penetrate the ore in a suitable manner. A layer of dry ore is first scattered over the bottom to soak up the water left in the filter, that the gas may pass upward freely. The charge is then thrown into the vat through a 1/2-in. screen, which breaks the lumps, and causes the ore to scatter loosely. When the vat has been filled a foot deep, the gas is intro-

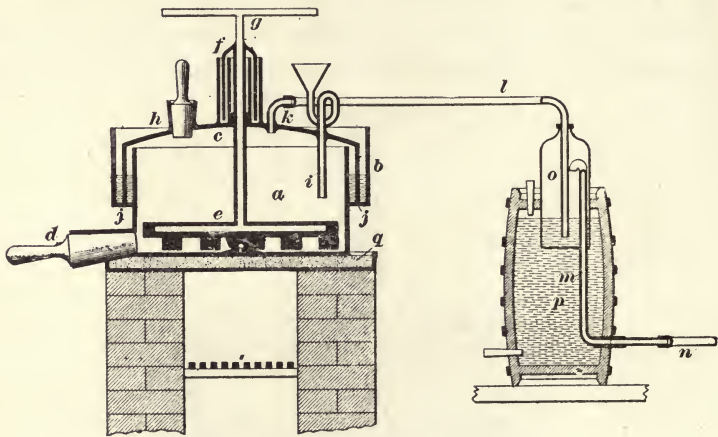

Fig. 59. CHLORINE GENERATOR.

duced from below and begins to rise through the ore. Charging is continued and the vat is filled within 3 in. of the top, and burlap-sacking is spread over the surface. The cast-iron cover *d*, is then brought by an overhead crane to the vat, and lowered upon it; and the joint between the cover and the top of the vat is made tight with clay-mortar and a strip of cloth. Chlorine gas, generated in a separate vessel, is allowed to enter the vat for 5 to 12 hours, according to the fineness of the gold. The finer the gold the faster is it chlorinated. The charge is known to be sufficiently saturated with chlorine when, upon opening the stopper *e*, on the cover, fumes of escaping chlorine gas can be detected by the odor. After this the covered vat is allowed to stand 24 to 40 hours to chlorinate.

In presence of moisture the soluble tri-chloride of gold is formed as follows:



The chlorine is produced in a generating vat (Fig. 59). This is of cast-iron, lead-lined, and has a heavy, tight cylindrical cover *c*. For a 4-ton charge of ore the vessel should be 24 in. diam. by 12 in. deep. It is charged by lifting the cover and putting in the solid chemicals, or adding these through the plug *h*. The chemicals consist of 20 to 27 lb. dioxide of manganese, 27 to 32 lb. common salt, and 40 to 60 lb. sulphuric acid of 66°B. The acid is added through the funnel-tube *i*, and is followed by 24 to 33 lb. water. The cover *c*, has a water seal *j*, which prevents the escape of the gas. The generator stands upon a sand-bath *g*, or preferably on a steam-bath or coil, by which it is heated to 60°C., the best temperature for generating the chlorine. The reaction is as follows:

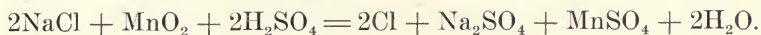

The stirrer *e*, is turned by the handle *g*, from time to time. This revolves on a projecting pivot at the bottom and has an inverted cup *f*, soldered to the shaft that forms an air-tight water-joint with the corresponding socket filled with water like that of the cover at *j*. The plug *d*, serves to discharge the exhausted contents of the generator. Through the delivery-pipe *k*, and the horizontal tube *l*, the gas passes to the wash-bottle *o*, where hydrochloric acid, if present, is absorbed by the water contained in the barrel *p*. The gas, thus washed, passes on by the tube *m* and *n* to the chlorinating tank, Fig. 58.

The charge, having remained in the vat an average of 48 hours it is ready for leaching. For leaching, the cover is removed, and water from a hose is run in, and evenly distributed over the ore. As soon as the ore becomes saturated and covered with water, the solution is allowed to escape through the hose *b*, which is lowered for that purpose. The level of the water is maintained at the top by a further supply until the escaping solution, on being tested, gives no reaction for gold. Two tons of water per ton of ore is used. The tailing or leached ore often contains silver, and this when in sufficient quantity, can be recovered later by hyposulphite-lixiviation. Thus at the Sierra Buttes mine, California, this tailing is leached 48 hours in vats 3.5 ft. diam. by 5 ft. high, with 3% solution of sodium-hyposulphite. The silver, precipitated from the filtrate by means of sodium-sulphide, is collected and sold.

The gold solution from leaching is conducted through a wooden

launder, either to a settling vat from which, after settling for several hours, it passes to the precipitating vat, or through a filter-bag, and then at once to the precipitating vat. When obtained from an 8-oz. ore, it may contain in solution, 1% of various base-metal sulphates, 0.9% metal-chlorides, 0.02% gold chloride, and 0.2% free chlorine.

The precipitating tank is 6 ft. diam. by 3 ft. high, painted (as also are the other tanks), with hot asphalt, to which has been added portland cement. The precipitant for gold is a solution of ferrous sulphate, prepared at the works by dissolving scrap-iron in sulphuric acid. It precipitates the gold as follows:

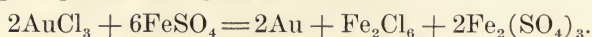

To save time, the precipitant is added with the first of the gold solution entering the tank and enough more is stirred into the solution to complete the precipitation. The vat is then covered, and the gold is allowed to settle 12 hours, or much longer. The clear supernatant solution is then run off, preferably through a filter-press (See Fig. 78), and the filtrate received into a sawdust filter to recover any particles of gold that escaped the press. Precipitation with ferrous sulphate has the disadvantage of being slow. The purple color, due to the presence of a trace of gold, can be detected in the solution days after precipitation. It is inferior to hydrogen sulphide in this respect. The residue in the tank is allowed to remain, and fresh solution in turn is run in and precipitated. The precipitate thus gradually accumulates. Finally, the precipitating tank is drained completely through the filter-press, and the residue is washed with dilute sulphuric acid to remove the ferric salt remaining. The moist product from the press is mixed with soda, borax, and nitre, and melted in graphite crucibles. The molten gold is poured into molds, and after removing the slag, is re-melted with a little borax to obtain a uniform bar. The gold thus obtained is 920 to 990 fine, the impurities being lead and iron. The extraction or recovery of the gold is 90 to 92 per cent.

Cost of plant and treatment.—The cost of erecting a plant in California, capable of treating 6 tons daily, is \$6000 to \$7000. In 1886 the cost of chlorination at the Providence mine, exclusive of supervision, interest, and depreciation, was \$6.30 per ton. About one-half of this (\$3), was the cost of roasting. This cost has since been considerably reduced by the use of oil fuel and by the employment of mechanical furnaces of the Edwards type (See Fig. 39).

35. BARREL CHLORINATION.

An example of an ore generally treated by chlorination is that of Cripple Creek: the ore (2) of the table. The ore contains gold tel-

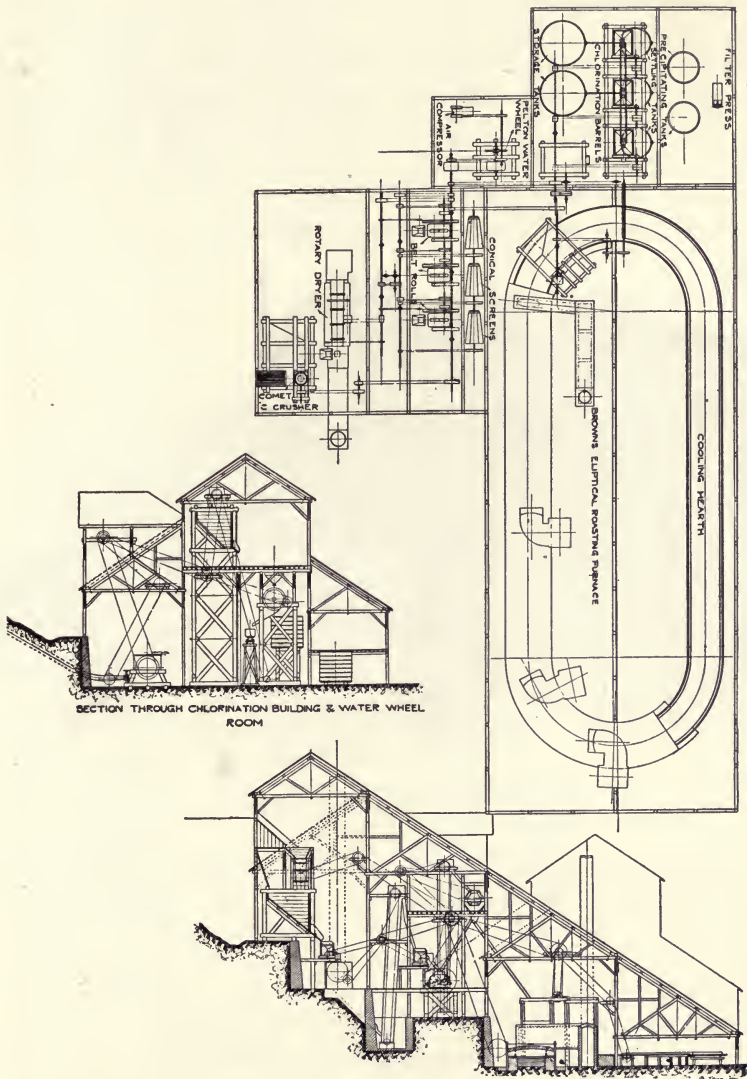

Fig. 60. SECTION THROUGH CRUSHING MILL AND ROASTER.

luride, and must be roasted to release the gold from combination with tellurium, and to expel all sulphur above 0.1%. The complete process of barrel-chlorination is as follows:

The ore is coarsely crushed in breakers and rolls to $\frac{3}{4}$ -in. size or less and placed in storage-bins. The crushing is done during the day-shift. Thus an accident to either the coarse or the fine-crushing system need not stop the operation of the mill.

The ore from any of the storage-bins is drawn off as needed to the feed-hopper of the dryer. It is dried and fine-crushed precisely as described in section 14, except that it need not be crushed finer than 10 to 16-mesh. By avoiding fine crushing, less dust is made, and after roasting, the product is pervious to the attack of the chlorine gas, and is more readily leached.

Cripple Creek ore is roasted in a mechanical furnace, such as

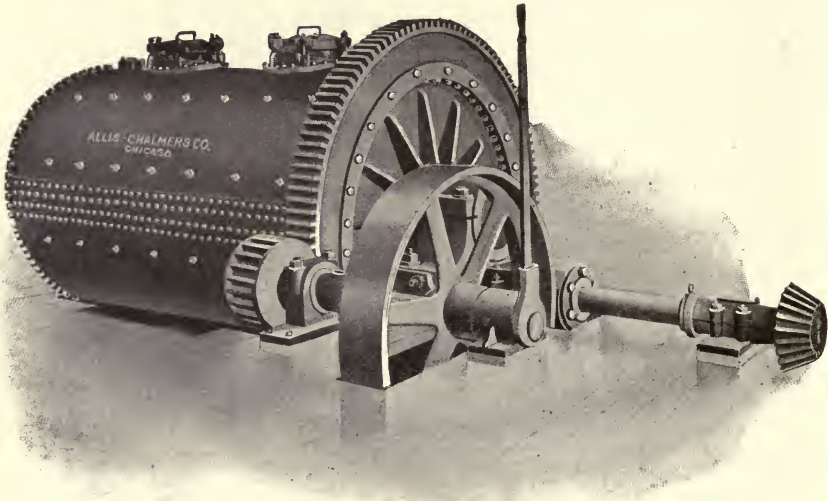

Fig.61. CHLORINATION BARREL.

the Wethey, Fig. 36 and 37, or the Edwards, Fig. 38 and 39. The finishing temperature should not be higher than necessary to break up the sulphates formed in roasting. In operating the Wethey furnace, the lower hearth is used to cool the roasted ore. The cooling is effected in the Edwards furnace by surrounding the troughs of the discharge conveyor by water pipes. Ore thus cooled is raised by an elevator to storage-bins, whence it is drawn as needed to the chlorination barrels.

The chlorination barrel.—These barrels, as shown in perspective in Fig. 61, and in transverse and longitudinal section in Fig. 62, are rotated on a horizontal axis. They are supported on trunnions, and driven at 12 rev. per min. The shell *d*, is of sheet-steel with heavy

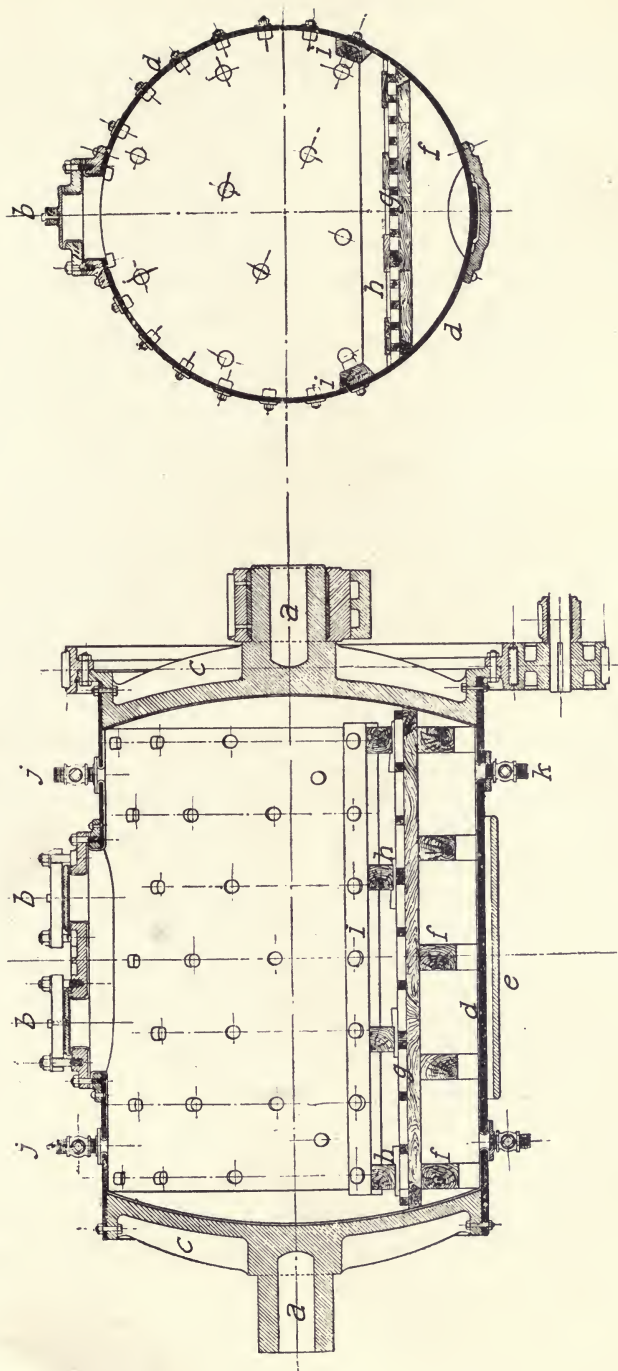

Fig. 62. SECTION OF CHLORINATION BARREL.

cast-iron ends *c*, and provided with two charging doors or man-holes *b, b*. The cylinder is lined with sheet lead $\frac{3}{8}$ in. thick, bolted to the shell. It contains, as shown, a filter-frame, or diaphragm *g*, of hard wood, intended for filtering the clear solution after treatment with chlorine, leaving the exhausted ore behind in the barrel. The filter is made of blocks *f* that sustain a floor of lead plates $\frac{3}{8}$ in. thick, perforated with $\frac{3}{8}$ -in. holes. The plate itself is corrugated to allow circulation of the filtrate over it. Instead of these plates, a perforated 2-in. plank floor has been used. Upon the plate (or floor), rests a lead sheet of 4 lb. per sq. ft. This sheet is perforated with 0.05-in. holes, $\frac{3}{8}$ in. between centers. To hold down the filter-sheet, a wooden frame or grating is placed upon it. This is held by blocks *h*, and heavy strips *i*, securely bolted to the barrel. The wood frames beneath last three months; those above, but two or three weeks. This wood-work, if immersed in boiling tar or asphalt until thoroughly impregnated, lasts longer and absorbs but little solution. In place of lead filters, a woven asbestos cloth may be used. The cloth needs renewal after 50 to 60 charges have been treated. Barrels have been made 6 ft. diam. by 16 ft. long, with a capacity of 18 tons. The common size, however, is 6 ft. diam. by 12 ft. long, and the capacity is 8.5 tons.

Charging the ore.—Crushed, roasted, and cooled, the ore, in weighed charges, is conveyed from the storage-bins in two-wheeled buggies, and placed in the charging hoppers that belong to each cylinder (See the charging hoppers of the Bruckner roasting-furnace, Fig. 35). Into the cylinder is first run 80 to 140 gal. water per ton of ore, enough to make with the ore, an easily flowing pulp. Next, a measured quantity of sulphuric acid is added, and then the charge of ore. Finally a weighed amount of 'bleach' or bleaching powder (CaCl_2O) is added. The quantity of chemical to be added to the charge depends on the nature of the ore, and is determined by experiment. On roasted Cripple Creek ore 12 to 15 lb. bleaching powder of 34 to 36% available chlorine, and 24 to 30 lb. sulphuric acid of 66°B. is used per ton of ore.

The charge-openings of the barrel are now closed. The barrel is started to slowly revolving (12 rev. per min.), for a period of 1 to 4 hours. In the case of Cripple Creek ore, for 3 hours. The chemicals enter into thorough contact with one another and with the ore, and react as follows:



Chlorine, in nascent condition, acts with greater energy upon the

gold then chlorine formed outside the barrel. With the gold it forms a soluble gold chloride thus:

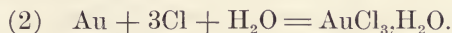

To determine when the ore is thoroughly saturated with chlorine, a stop-cock *j* is opened and gas that issues is tested for chlorine with ammonia which produces a white fume of NH_4Cl with chlorine. If free chlorine is not detected, the barrel is stopped, opened, and more bleach and acid added. In place of using chloride of lime and sulphuric acid, as above described, chlorine (about 1 lb. per ton of ore), has been introduced into the barrel in liquid form. Chlorine can be obtained in this form, in strong steel cylinders or drums.

After saturation with chlorine the barrel is revolved an hour, then stopped in position for filtering with the filtering diaphragm down and level. The outlet pipe *K*, is connected by a hose to the settling tank and opened; and water is pumped into the barrel above the charge through the valve *j*. The solution is now drained off, and the water above the charge forced rapidly through by means of compressed air introduced through the valve *j*. The excess of chlorine is absorbed by the wash-water, and does not enter the building. The operation of filtering is suspended, connections are broken, valves closed, and the barrel revolved a few times to mix the contents again, and to break up channels that may have formed during the leaching. The barrel is then stopped, water run in, compressed air admitted, and the washing resumed. This is repeated until no gold is found in the escaping filtrate when tested. The compressed air admitted is under a pressure of 40 lb. per sq. in. The time of filtering and washing on an average is $2\frac{1}{2}$ hours. The water used is 50% the weight of the ore. All connections are finally broken, valves closed, and man-holes opened, and the cylinder is revolved several times to discharge the contents. It is then washed out with a hose to prepare it for another charge.

The solution from the barrels runs into lead-lined or asphalt-coated settling-tanks 10 ft. diam. by $7\frac{1}{2}$ ft. high. Here any sediment which escaped the filter is settled in about 8 hours. The clear supernatant solution is withdrawn at a point 10 in. above the bottom of the settling-tank to avoid disturbing the sediment, and run into the gold-solution tanks on a lower level, where it is stored. The clear solution from the gold-solution tank is pumped through the opening *A*, Fig. 63, into the precipitation tank *X*, which is 10 ft. diam. by 12 ft. high. The free chlorine is removed by passing sulphur dioxide through the solution from the SO_2 generator *H*. This generator

is a cast-iron receptacle containing a pan *F* in which sulphur is burned. Compressed air, admitted from a pipe *W*, supplies oxygen to burn the sulphur to SO_2 and pressure to drive the fumes into the solution along the pipes *o, v* and the lead pipe *r*, through numerous

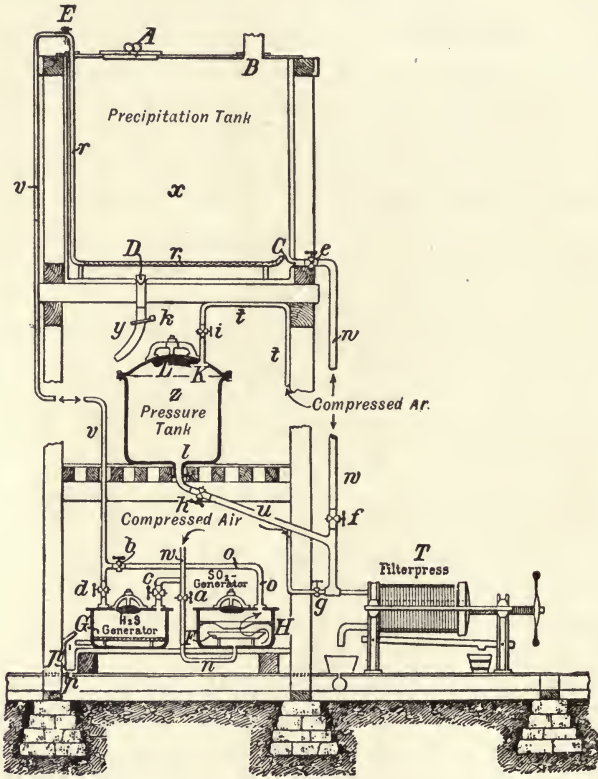

Fig. 63. PRECIPITATION APPARATUS OF BARREL CHLORINATION.

small holes where the horizontal part of the pipe crosses the bottom of the tank. The sulphur dioxide acts upon the chlorine as follows:



Sulphuric and hydrochloric acids are formed by the action of sulphurous acid upon chlorine, and both remain in aqueous solution. The operation is completed in 15 to 20 minutes as indicated by testing the solution with H_2S , when a permanent precipitate forms.

The chlorine having been removed, we are ready to precipitate the gold by passing in H_2S . To do this, the pipe *v* is connected to the lead-lined generator *G* which contains lumps of iron sulphide resting

on a perforated lead false-bottom. Dilute sulphuric acid admitted below the false-bottom comes in contact with the iron sulphide and abundantly generates H_2S according to the equation:

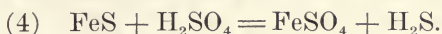

Compressed air, entering by the pipe w and the valve c , drives the gas through the pipe v and the lead pipe r into the solution in the tank, and precipitates the gold as follows:



The gold is thus thrown down as an auric sulphide in a solution containing both sulphuric and hydrochloric acids. The precipitation is rapid, taking about 10 minutes, and, it is possible by selective precipitation and careful working to leave copper in solution while precipitating the gold. Where the chemicals in the generator become exhausted, the waste liquid is discharged into the waste-laundry p . The chemicals consumed per ton of roasted ore are, 1 lb. iron sulphide, $\frac{1}{4}$ lb. sulphur, and $2\frac{1}{2}$ lb. sulphuric acid.

More recent treatment does not include the use of SO_2 gas, H_2S gas alone being used. At first, H_2S is oxidized by the chlorine, thus:



Sulphuric and hydrochloric acids are formed by this reaction after which auric sulphide is precipitated as in equation (4).

After being precipitated, Au_2S_3 is allowed to settle two hours. The clear solution then is drawn off at C , 10 in. above the bottom of the tank, through the pipe n into the filter-press, where it is filtered under its own hydrostatic head of 25 ft. This is done to recover any possible flakes of gold sulphide that failed to settle in the tank x . In three or four hours after precipitation, the tank can receive a fresh charge of gold-bearing solution.

The precipitate collects upon the bottom of the tank, and after several charges have been treated, the united precipitate is drawn off at D and delivered through the man-hole L into the pressure-tank z , by the hose y . The precipitating tank is then washed clean with the aid of a hose. The pressure-tank is 4 ft. diam. by $4\frac{1}{2}$ ft. high. When charged, the cover L is clamped in place, and compressed air, under a pressure of 40 lb. per sq. in., is admitted through t . At the same time connection is made to the filter-press T through the pipe u , and the precipitate collects in the press under the above pressure. This filter-press is more clearly illustrated in Fig. 78. A set of filter-frames outlasts the treatment of 6000 to 8000 tons of ore. The filtrate from the press passes over a sawdust filter-bed, as a safeguard, before it is run to waste. The sawdust is collected occasionally, and

burned, to recover the small amount of gold which it may have caught.

The precipitate of gold sulphide also contains sulphur, and sulphides of arsenic, antimony, copper, and silver, forming a 'sulphide cake'. The press is next opened and the cake is withdrawn. While still moist it is placed in trays 44 in. long, 24 in. wide, 4 in. deep, and mixed with borax, nitre, and soda. The trays are then placed in cast-iron muffles that are heated by coal, and connected to a flue-chamber, where any mechanically escaping flue-dust is caught. The precipitate dries here, and after drying, the temperature is raised to decompose and expel the sulphides, the operation taking an hour. The roasted material has a light-brown color, and contains 70 to 80% of gold. It is carefully transferred to a crucible and melted in a wind-furnace. The content of the crucible, including the slag, is poured into a conical mold where the gold collects at the bottom. Upon cooling, the gold ingot, 900 to 950 fine, is separated from the slag; remelted, and cast into a bar suitable to be forwarded to the United States mint. After deducting a charge of 2c. per ounce for melting and assaying, the gold at the mint should net \$20.65 per ounce of contained gold.

The slag, from the melting operation, may be melted again with one-seventh its weight of litharge with a reducing agent, and a lead button obtained. This lead can be scorified several times, until it is reduced to a small button, and finally cupelled to recover the small amount of additional gold.

The cost per ton of treating Cripple Creek ores, on a large scale, by barrel chlorination, is as follows:

Labor, including salaries	\$1.34
Chemicals and supplies	0.72
Fuel, roasting and power	0.70
Renewals and repairs	0.45
General expense	0.32
	<hr/>
Total cost per ton	\$3.53

The cost of sulphuric acid, 66°B., is 0.9 to 1.1c. per lb.; bleaching powder 1.8c. (New York); sulphide of iron 3c. (this can be made at the works from scrap wrought-iron and sulphur); sulphur 2 cents. The water needed is approximately two tons per ton of ore treated, which includes that used for power. This quantity can be reduced if settling tanks are employed and the water used again.

Following is a flow-sheet indicating the procedure in the barrel-chlorination process above described.

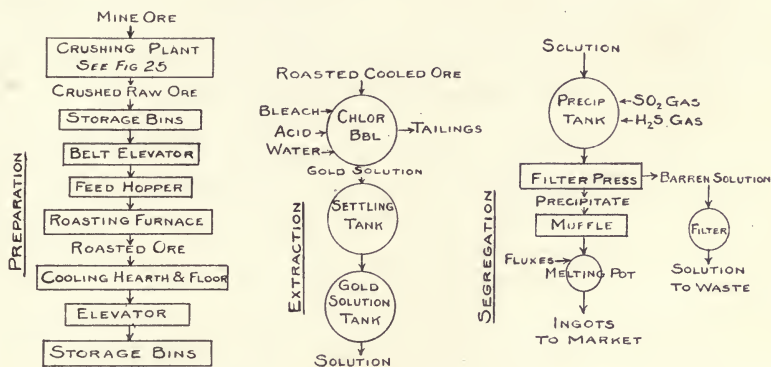

Fig. 64. FLOW-SHEET OF BARREL CHLORINATION.

36. CYANIDATION OF GOLD (AND SILVER) ORES.

The process of cyanidation consists in attacking the gold or silver contained in ores with dilute solutions containing 0.5 to 0.7% of potassium cyanide. If the ore contains pyrite it may be acid as the result of weathering. Before applying potassium cyanide this acidity must be corrected by adding caustic soda or quick-lime. The gold-bearing cyanide solution is filtered off, and the precious metals contained are precipitated upon zinc shavings, zinc dust, or by electrolysis. The precipitate is collected, treated to purify it, melted, and cast into bars or ingots of metal. The solution, free from gold, called 'barren solution', is used again.

The cyanide process is a success with many ores. The field of its usefulness is extending, not only in the variety of ores, but ores containing smaller and smaller amounts of metal are being treated. An important advantage of cyanidation over chlorination is that roasting by no means is essential though sulphides be present. Sulphides containing silver, however, must be small in quantity, if silver is to be extracted in a period of time compatible with economy.

Dilute cyanide solution has a selective action in extraction and can dissolve gold and silver from an ore, at the same time attacking but little the base-metals that are present. If, however, copper is present in soluble form it consumes cyanide, though in modern practice a small quantity is not considered a serious obstacle.

Ores suited to cyanidation.—With reference chiefly to gold, we have the following classes of ores :

(1) **Free-milling ore.**—Those in which gold occurs in a fine or microscopic form, and in which panning reveals to the naked eye few or no visible colors of gold. Where gold particles are coarse the time required to dissolve them is long, and cyanidation becomes impracticable. It is possible, however, to remove coarse gold by amalgamation, and after so doing the residue can be treated by cyanidation.

(2) **Telluride ores.**—Before these ores are cyanided they must be treated to liberate the gold from its combination with tellurium. When rich and containing telluride in spots, roasting develops shots or particles of gold, and these must be removed by amalgamation or concentration before cyaniding.

(3) **Pyrite ores.**—The gold in such ores is supposed to occur in the form of films on the surface of the pyrite crystals. When these are crushed fine to expose fresh faces, the gold can be dissolved by cyanide. Some pyrite ores, however, contain the gold within the substance of the crystals, and these ores must be roasted before cyaniding. Roasting improves ore by rendering it more porous, and hence more accessible to the solution. It destroys the colloid of slime, and makes a material more easily filtered.

(4) **Talcosse or clayey ores.**—These, when crushed for cyaniding, produce much slime that is impenetrable by solution, and can not be leached. Slime is treated in a way that adds to the cost of extraction. Roasting, as stated, would accomplish this end, but the cost would be prohibitory in some cases.

37. DEVELOPMENT OF THE CYANIDE PROCESS.

This process, originally called the MacArthur-Forrest process, was patented and vigorously advanced by the inventors. It was first put in practice at the Robinson mine on the Rand, South Africa, and applied to the recovery of gold in large tailing-dumps, that had accumulated in stamp-milling and had been impounded behind crib-work, or low dams. This tailing was leached in filter-bottom vats with cyanide solutions. The gold-bearing filtrate was passed through zinc-boxes, containing zinc shavings, to precipitate the gold, and the precipitate was purified and the gold collected and cast in ingots. So long as these dumps lasted the simple process was sufficient, but when it became necessary to treat the tailing immediately from the mill, another kind of practice was begun. This 'second method' in outline is as follows: The ore is crushed and amalgamated in the customary way. The tailing from the amalgamated plate is classi-

fied into two products, one of which consists of coarse sand, the other of slime and fine sand. The coarse sand is more readily leached when freed from slime. To correct the acidity, milk of lime is added to the finer portion as it passes through the launder to the leaching-vats. The sand here settles and the slime passes on, suspended in the escaping water. When the tank is filled it is drained, and the contained water is replaced by weak cyanide solution. Discharge-valves or doors (See Fig. 68), are opened and the contents of the vat are shoveled into a vat directly beneath. A solution of 0.15 to 0.25% cyanide is allowed to percolate some days through the sand, and then is displaced by a weaker solution, and the weaker one by water. The gold in the gold-bearing filtrate is precipitated on zinc shaving, and the solution, after removing the gold, is used again. This is called 'double treatment', since the extraction of gold, begun in one vat, is completed in a second one. While a little more expensive in equipment and in handling, it is more thorough. The coarse sand requires much longer time to leach than the fine sand, and hence is treated separately.

The slime is caught in large tanks and allowed to settle. After settling, the clear supernatant water is drawn off. A 0.01 to 0.02% solution of cyanide is added to the thickened slime remaining in the tank, and the whole is agitated by a mechanical stirrer for some hours. It is then settled, and the clear gold-bearing solution is drawn into a gold-solution tank, from which it is supplied in a regulated stream to the zinc-boxes for precipitation. The residual slime is treated again with weak solution, settled, and decanted. The spent slime then is washed out to the dump.

This method of treatment is slow, and requires a large number of tanks; and gold is carried away in the solution that remains in the slime. To overcome these difficulties filter-pressing has been tried. The slime, after agitating as above described, with cyanide solution, is pumped through a filter-press (Fig. 78), where it is separated and washed, and the filtrate is collected in the gold-solution tank, while the exhausted slime removed from the press is thrown away. The trouble with filter-pressing, as ordinarily practiced, is that it is expensive and slow. A number of costly presses are required for a large plant and these consume power and require labor to operate them. In the United States this has led to the adoption of suction-filters of the Moore type. In South Africa, Western Australia, and elsewhere, the Butters and Ridgway filters have given good service, while pressure-tank filters of the Blaisdell type, that use filter-leaves in the same general way, have advocates.

Western Australian ores require fine grinding, to liberate the gold. While fine material cannot be leached in vats, it can be filter-pressed. This has led to the use of the grinding pan as in silver milling, and to the tube-mill in particular, which has proved particularly well adapted to fine grinding. The outline of the process as practised in Western Australia is as follows:

The ore is coarsely crushed in rock-breakers, then dry-crushed either in a Griffin mill, a ball mill, or rolls. Western Australian ore containing tellurides must be roasted to decompose and expel the tellurium, and liberate the gold for attack by cyanide solution. By roasting, the ore becomes porous, and colloidal compounds are destroyed, yet it is necessary to grind fine if a high extraction is to be obtained. The pulverizing has been done in grinding-pans or tube-mills, in the presence of cyanide solution. The product is sent to a settler to remove large particles of gold, if present, and all the pulp is then filter-pressed, and washed in the press, the process giving an extraction of 93 per cent.

The trend of modern practice is toward fine grinding, and treatment of the whole product as slime, under the idea that the fine re-grinding of the product insures pulverizing the coarse gold, so that it can be cyanided in reasonable time. The alternative process to this is to finely grind the product, classify it into sand and slime, and treat the sand by percolation and the slime by pressure of suction filtration.

38. THE CHEMISTRY OF THE CYANIDE PROCESS.

When a solution containing 0.5% potassum cyanide is brought into contact with finely-ground ore containing gold in microscopic particles, the gold gradually goes into solution. The reaction that occurs was first shown by Elsner, and is called Elsner's equation. It is as follows:

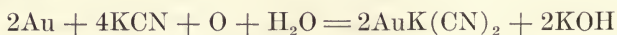

The gold is dissolved by the action of potassium cyanide in the presence of oxygen and water; the compounds formed are auro-potassium cyanide and caustic potash.

Silver, but more slowly, dissolves according to a similar reaction, thus:



It is noticed that oxygen is needed to fulfil the requirements of the reaction, and consequently ore, or solution acting on ore, must be in some manner aerated. When oxygen of the dissolved air is consumed, action ceases, but it proceeds again with access of fresh air.

Oxidizing agents like potassium-chlor^{ate}~~ide~~ and permanganate, and the peroxides of lead, manganese, and sodium may be used to furnish oxygen, in place of air, but are too expensive for practical use.

When an ore containing pyrite is exposed to the weather, air and moisture slowly act upon the pyrite, according to the reaction :



Ferrous and ferric sulphates and sulphuric acid are thus formed. The two first named would tend to precipitate gold. Ferric sulphate is acid in its reaction, and with the sulphuric acid, if unneutralized it would decompose and cause a serious loss of potassium cyanide. Such compounds are called 'cyanicides'. Ore, therefore, that contains pyrite, and that has lain exposed to the weather, needs caustic soda or quick-lime $\text{Ca}(\text{OH})_2$ to neutralize the acidity, and an excess to provide for the acid resulting from further decomposition. This excess is the 'protective alkalinity' as it is called. To remove the soluble ferrous sulphate and sulphuric acid, a water-wash before treatment would be sufficient. This would require much time and in place of it quick-lime is added. Quick-lime acts upon the products of the above reaction as follows :

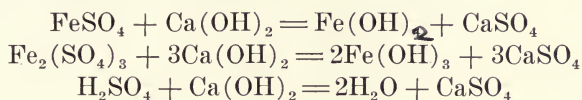

The reaction causes the formation of a harmless iron hydroxide and calcium sulphate.

The reaction that occurs when gold-bearing solution comes in contact with zinc shaving in the precipitating boxes, or when 'zinc dust' is stirred into such a solution, is generally assumed to be a simple replacement of zinc by gold, thus :



The gold falls as a brown or black precipitate, while the zinc potassium cyanide remains in solution.

The barren cyanide solution from which gold has been removed is used repeatedly, and accumulates impurity from the ore, and from the zinc with which it was in contact in the zinc-boxes. In consequence it becomes gradually less efficient than fresh solution. It has been found that the addition of quick-lime increases the solvent action of cyanide solution upon pure quartz ore, but it is without effect on ore containing sulphide. Such solution, if treated with sodium sulphide to the point of exact neutrality, and with a small excess of lead acetate, and given time to permit the resultant sulphide to precipitate, is improved in extractive power thus :



The cyanide is here regenerated, while the zinc sulphide separates. This is a means of overcoming the accumulation of zinc in solution which is one of the drawbacks to the use of zinc for precipitation compared with electrical deposition.

We are not, however, altogether dependent upon chemicals to dispose of the zinc. We have shown by Elsner's equation that caustic potash is set free. Caustic potash reacts upon sulphide contained in the ore and causes the formation of a soluble sulphide which in turn reacts like the sodium sulphide in the reaction above, and precipitates zinc sulphide upon the ore.

The following minerals and chemical compounds destroy or combine with cyanide, and render it incapable of dissolving gold:

Copper in the form of sulphate, carbonate, copper glance, erubescite, or copper pyrite. The sulph-antimonites of copper are without action. Manganese as 'wad' (impure hydrous oxide), but not the carbonate or oxide. Zinc as calamine, but not blende or zinc silicate. A distinct loss is traceable to the presence of organic matter like grass-roots, decayed wood, etc.

To increase the activity of zinc shaving in precipitating of gold it may be dipped in a 10% solution of lead acetate just before it is placed in the zinc-boxes. Lead is precipitated upon the surface of the shavings, forming zinc-lead couples, which electrically react upon the gold in solution.

39. CLASSIFICATION OF CYANIDATION METHODS.

First method.—For oxidized ore which forms but a moderate amount of slime when crushed and can be leached, and in which the contained gold is fine and free. Example: Mercur, Utah.

Second method.—For ore that crushes with the formation of slime and contains both coarse and fine gold (coarse gold can be recovered by amalgamation), and pyrite and other sulphides, that can be removed by concentration. The tailing is separated into sand and slime. The sand is treated by leaching. The slime is either rejected or treated by: (a) **Decantation.**—Best example: South Africa. (b) **Filter-pressing.**—Best example: Homestead mine, South Dakota. (c) **Vacuum-filtration.**—Best examples: Terry, South Dakota, Liberty Bell mine, Colorado; Goldfield, and Virginia City, Nevada.

Third method.—For ore that contains both coarse and fine gold. The coarse gold is recovered by amalgamation, and a large part or the whole of the tailing from the plates, is re-ground or slimed in pans or tube-mills. The ground product is agitated and treated by

decantation, filter-pressing, or vacuum-filtration. Concentration is omitted. Best example: El Oro, Mexico.

Fourth method.—For ore that contains fine gold only. The crushed ore is classified into sand and slime, the former being leached. Concentration is omitted. A feature of the process is that the ore is crushed in weak cyanide solution. Best example: Maitland mill, South Dakota.

Fifth method.—For ore that contains gold in combination with tellurium. The ore receives an oxidizing roast after which it can be treated by the 'first method'. As the result of roasting some of the gold may take the form of shot, beads, or coarse particles of gold that settle and must be caught by a classifier, riffle, sluice, concentrating table, or amalgamated plate. If ore is re-crushed in tube-mills, the shot or coarse gold becomes ground so fine it all may dissolve in the cyanide solution. Best examples: Cripple Creek and Western Australia.

40. FIRST METHOD OF CYANIDATION.

This was the first method put in practice for the treatment of gold ores. It is applicable particularly to free-milling gold ores, in which the gold is in a free or uncombined state. Also, since the cyanide solution acts but slowly upon gold, it is necessary when using this method, that the gold particles be extremely fine; otherwise it requires a long time to leach the ore. When coarse gold is present it is first caught on amalgamated plates. The ore is crushed preferably by rolls to avoid the formation of slime, which would interfere with the leaching. The crushed ore is leached in vats with weak cyanide solution, and the gold is precipitated from the filtered solution by passing it through boxes, treated, and obtained in the form of gold ingots.

Method of crushing.—A comparison between stamps and rolls shows the former to be durable, less expensive to install, and capable of finely crushing ore from a rock-breaker. Where stamps are used the ore is wet and four to eight tons of water is needed per ton of ore. They make a greater proportion of extremely fine material or slime in crushing than rolls. Where ore contains tale or clay, that would cause it to slime, rolls give a more granular product, and one that is more easily percolated or leached by the cyanide solution. With good rolls, an efficient system of graded crushing can be used and dry crushing is preferred for the following reasons:

(1) The ore after crushing is delivered dry to the leaching-

tanks, and there is no dilution of solution as when treating a wet-crushed ore which contains 10 to 20% moisture.

(2) In dry-crushing water is not needed. This is an important consideration in a dry country where water is scarce.

(3) A uniform bed of easily percolated ore can be put in the

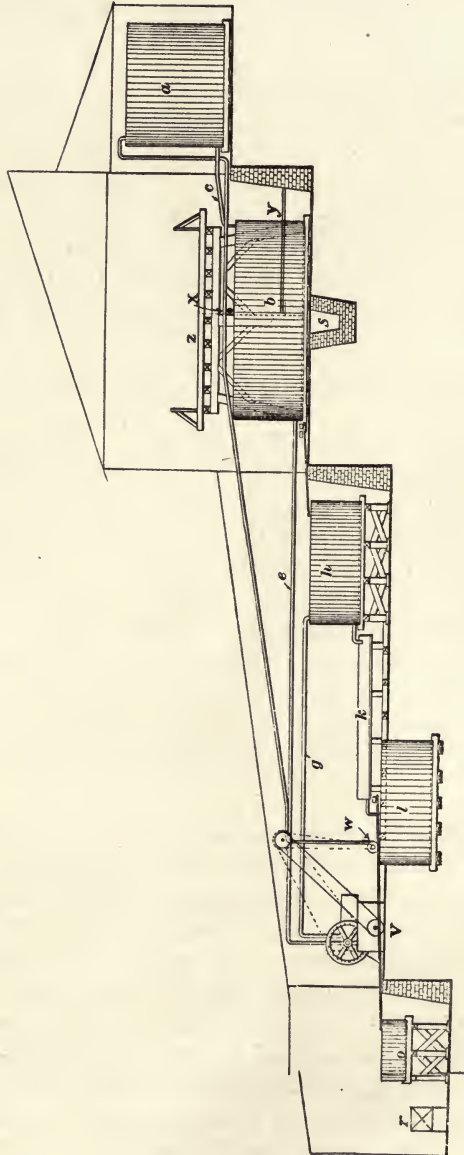

Fig. 65. ELEVATION OF CYANIDE PLANT.

leaching-tank, the ore is better aerated, and the oxygen present assists in the solution of the gold, as shown in Elsner's reaction.

On the other hand the cost of dry crushing beyond 40-mesh is excessive.

Leaching tailing.—Fig. 65 and 66 represent, in sectional elevation

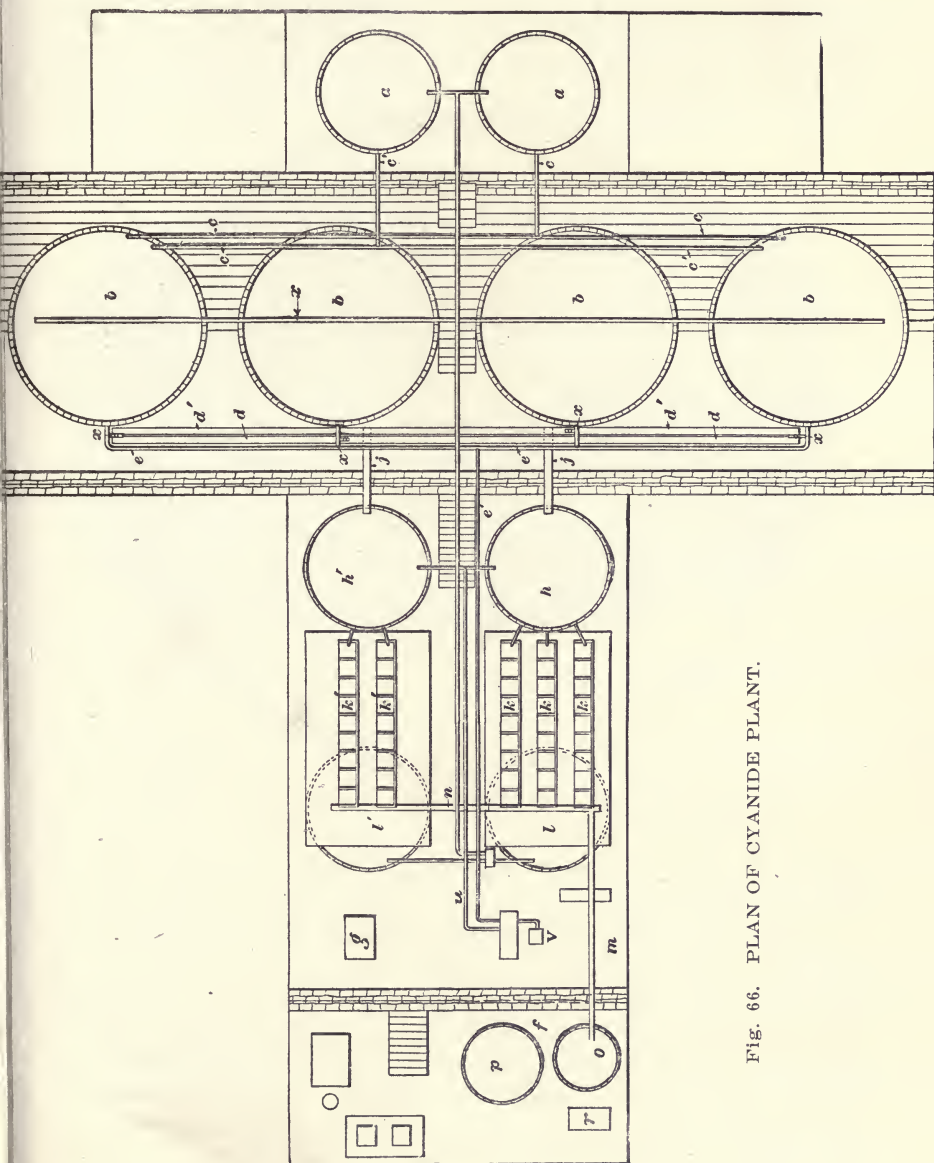

Fig. 66. PLAN OF CYANIDE PLANT.

and plan, a 75-ton plant designed to treat impounded tailing, which has accumulated from a mill treating gold ore of a kind suited to this method. The tailing contains so little slime that only 37% passes an 80-mesh sieve; and the gold can be extracted by four days leaching.

Referring to plan, Fig. 66, *b, b, b, b*, are the leaching vats (sometimes called percolators) the most important units of the plant, and the ones to which the others are accessory. They are 20 ft. diam.

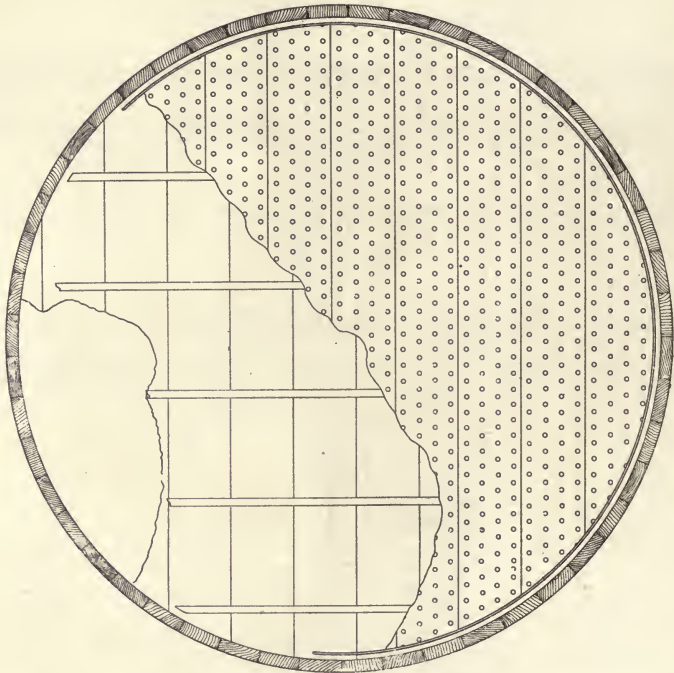

Fig. 67. WOODEN LEACHING VAT SHOWING FALSE BOTTOM.

by $6\frac{1}{2}$ ft. deep, having 75 tons capacity above the filter-bottom. The four together allow four days treatment for each charge.

They are constructed with filter bottoms, as shown in Fig. 67 and in perspective Fig. 68. They may be made of wood or steel. In warm countries, like Australia, South Africa, or Mexico, the steel vat is to be preferred; but in cold countries, where it is necessary to house the plant, the wooden vat gives satisfaction. The latter is cheaper in first cost and easier to set up, though the wood absorbs gold solution. The steel vat on the other hand is less liable to leak, but costs more to maintain in requiring a

periodical coat of protective asphalt paint to preserve the steel from the action of the cyanide solution. A wooden tank, also, when requiring it, should be painted. In Western America wooden vats predominate. They are carefully built by companies who make this their business. Steel vats are also used. Each kind has advocates, but in general the steel vat is preferred.

Fig. 68 is a perspective view of a wooden vat with the filter-cloth omitted. This shows the false-bottom of slats and the hinged bottom-discharge opening through which the exhausted tailing is shoveled or sluiced out. A wooden ring, 2 in. high and $2\frac{1}{2}$ thick,

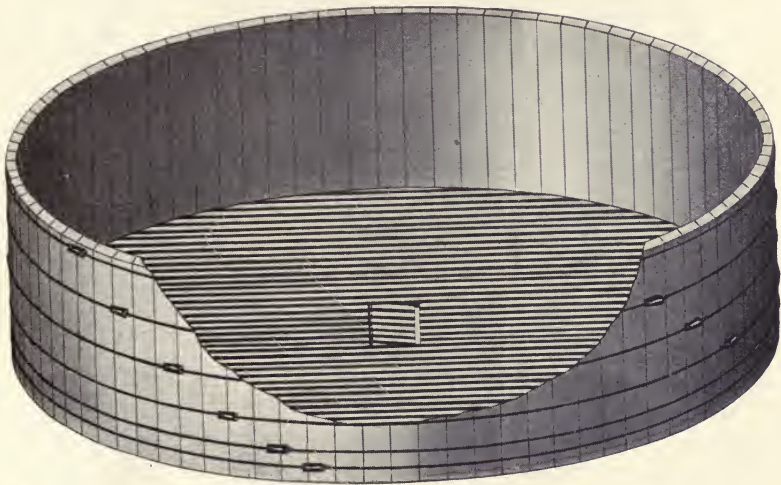

Fig. 68. PERSPECTIVE VIEW OF WOODEN LEACHING VAT.

is nailed to the bottom of the vat, leaving a space of $\frac{3}{4}$ in. between it and the side. Parallel strips, one inch high, are nailed a foot apart upon the bottom, and across these 1 by 4 in. strips or slats are laid with 1-in. space between. Upon this false-bottom cocoa-matting is spread, and over it 8-oz. canvas filter-cloth cut 12 in. larger in diameter than the vat. The edges of the cloth are held down by a rope laid upon the canvas and driven into the $\frac{3}{4}$ -in. space between the staves and the wooden ring. This way of securing the canvas is shown in further detail in Fig. 71.

Fig. 69 gives, in plan and section, the construction of another form of filter-bottom for a wooden leaching-vat. Wooden rings of graded heights are nailed to the bottom of the vat and upon these are nailed radial pieces bored with $\frac{3}{4}$ -in. holes. This arrangement of a sloping bottom facilitates the discharge of tailing when sluiced

or hosed out of the vat. The wooden ring, in Fig. 67 is omitted and instead, the joint is made by nailing a wooden strip around the tank so as to hold the canvas tight against the staves.

Fig. 70 and 71 represent, in plan and in elevation respectively, the construction of a steel vat having a perforated board bottom.

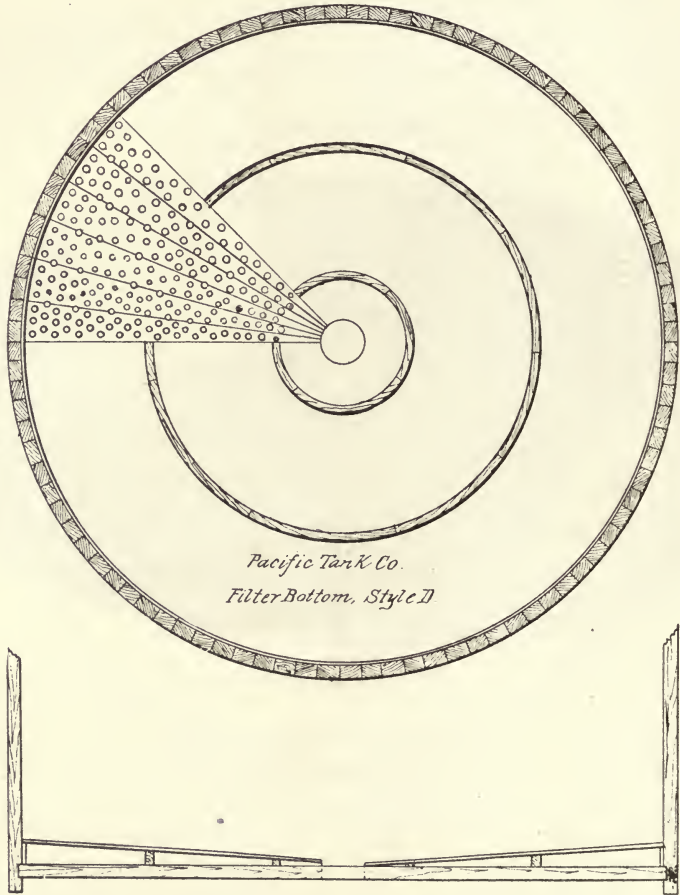

Fig. 69. PLAN AND SECTION OF WOODEN LEACHING VAT.

A ring of flat iron $\frac{1}{2}$ by $2\frac{1}{2}$ in. is rivetted to the side of the tank, with space-thimbles to hold it $\frac{3}{4}$ in. from the side. The cleats that sustain the false-bottom are 2 in. high by $1\frac{1}{2}$ in. wide. The 1-in. bottom-boards are bored with $\frac{3}{4}$ -in. holes and screwed to the cleats. As in the case of the wooden vats, the thick stiff cocoa-matting is laid upon the false-bottom, and covered with a filter-cloth of 8 to

10-oz. canvas. The edges are calked with a $\frac{3}{4}$ -in. rope into the $\frac{3}{4}$ -in. space, as shown at *g* in the sectional view, Fig. 71.

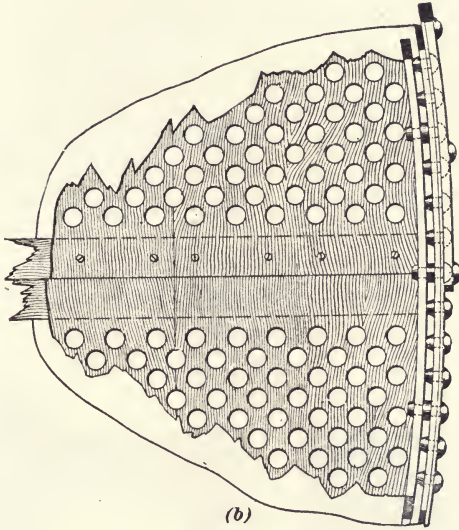

Fig. 70. PLAN OF STEEL LEACHING VAT.

Leaching vats vary in size from 16 to 50 ft. in diam. and 4 to 9 ft. in depth. The shallow ones are for the more finely-ground sand. The tank is generally made to hold one day's supply of ore to insure

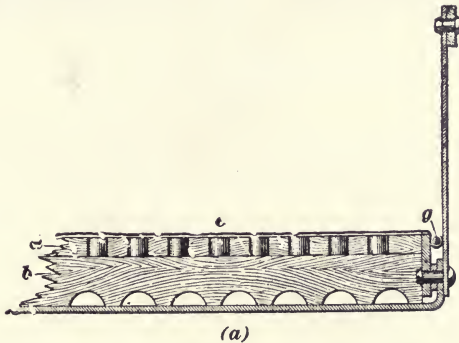

Fig. 71. SECTION OF STEEL LEACHING VAT.

uniform work in the mill. Hence the number of tanks indicates the number of days of treatment.

The exhausted sand of the vat may be shoveled out through side or bottom openings, or, where water is abundant, may be washed by

a hose into a launder as shown in *s* Fig. 65, and thus conveyed to the dump.

Fig. 72 represents a side-discharge door which is bolted to the outside of the vat, and which can be quickly opened or closed. The joint between the door and frame is made tight with a rubber gasket. Fig. 73 is a bottom-discharge valve. Opening upward, it is conveniently operated from the platform above the tank when the charge is to be sluiced out. It is securely bolted to the bottom, and is self-sustaining. For a large tank four such valves may be used. The opening in each is 10 in. diam. In Fig. 68 is shown a drop-bottom door that opens from below.

At *Z* Fig. 65, is the charging platform or bridge (not shown in Fig. 66), grated where it is over the vats, with 2-in. openings. The

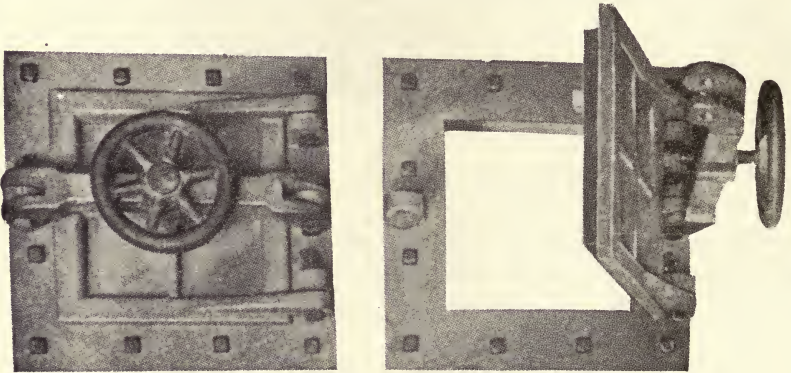

Fig. 72. SIDE DISCHARGE DOOR.

tailing is brought by a wagon having movable bottom-planks, and dumped upon the grating from which it falls lightly into the vat. When full the surface is leveled with a hoe. At *y* is a platform set 4½ ft. below the top of the vat for convenience in leveling the ore and in adjusting the supply-valves. At *a* and *a'* Fig. 66 are the strong and weak-solution stock-tanks, one of which contains 5 lb. potassium cyanide solution, the other a weak solution, 0.1%, or 2 lb. per ton. These tanks deliver solution to the leaching-vats by pipe *c* for the strong and by *c'* for the weak solution. The filtrate from the vats goes by a double launder, *d* for the strong and *d'* for the weak solution. These deliver by the cross-launder *j* and *j'* to the strong gold-solution tank *h* and the weak gold-solution tank *h'*.

Charging the vat.—Where tailing has been accumulated in dumps, it is coarser at the point of discharge from the mill and

finer toward the further limit, and to treat the accumulation, the two must be mixed. They may be mixed in the reservoir by plowing and breaking up the lumps with a disk-harrow. When the material has become pulverized and dry it is scraped into heaps. The coarse and fine are together shoveled into a wagon, and the mixing is completed when the tailing is dropped from the wagon, through the grating, into the leaching vat. The material should be loaded evenly into the vat and should fill it, so that when settled by the wash-water,

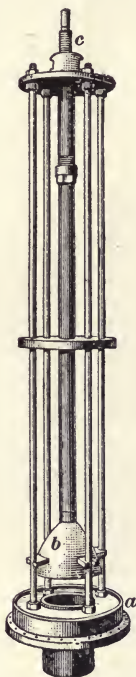

Fig. 73. BOTTOM DISCHARGE VALVE.

the level will be 10 in. below the top. This gives room for the wash-water and cyanide solutions. Since the tailing is acid and the acid would destroy potassium cyanide, it is necessary to add a certain proportion of slaked quick-lime when charging into the vat.

Leaching the ore.—A drop-pipe from the strong-solution pipe *c* extends just below the filter bottom; and by this a 0.25% KCN solution is introduced. It rises through the ore and is shut off when the ore is covered 2 or 3 in. deep. The charge is allowed to remain in this condition a fixed time after which the discharge-valve at the bottom of the tank is opened and the solution, at first weakened by the water it has taken from the charge, is run to the

weak-solution gold-tank. The strength steadily increases and when above 0.1% (the grade of weak solution) the solution is turned into the strong-solution gold-tank.

Percolation now proceeds, solution being added above the surface of the charge in a succession of washes between each of which the

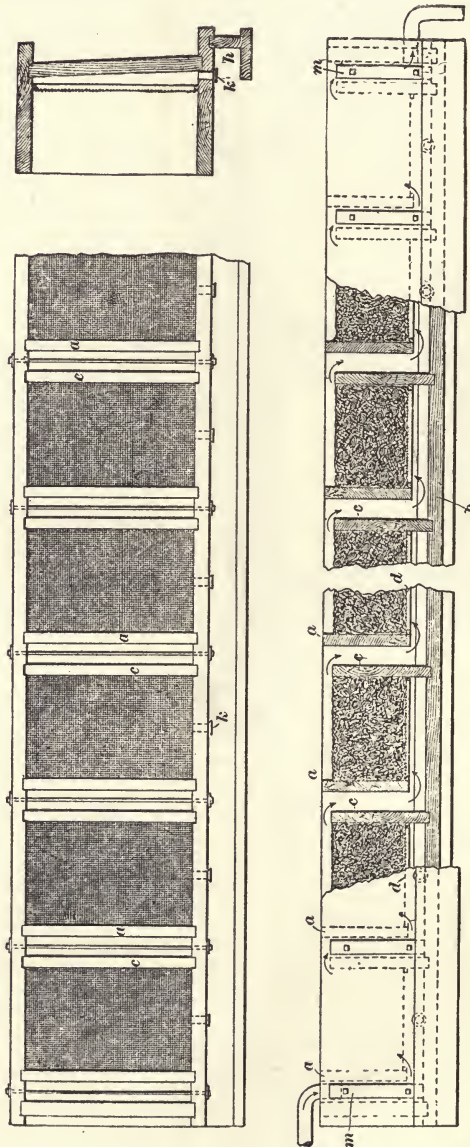

FIG. 74. SECTIONS OF ZINC BOXES.

solution is allowed to sink beneath the surface, to draw air into the charge. Weak solution is now admitted above the charge to displace strong, and as the effluent weakens it is turned into the weak-solution tank taking care to prevent a needless accumulation of weak-solution, by using as little as possible.

Displacement of one solution of the charge by another does not take place uniformly; the compactness of the charge is irregular and the more permeable parts allow the quicker advance of the solution last added, causing it to mix more or less with that preceding. It has been found, in fact, that of weak solution $1\frac{1}{2}$ to 2 times the theoretical quantity is needed to displace the strong. Different charges percolate at different rates, and no hard-and-fast rule can be established for handling tailing. Each charge should



Fig. 75. PERSPECTIVE VIEW OF ZINC BOXES.

be studied by itself, and frequent samples of the out-going solution must be chiefly relied on to make sure of proper extraction.

The cycle of treatment of a 75-ton charge is as follows:

	Hours.
Charging, or filling the vat with tailing.....	9
Leveling charge and saturating with strong solution	3
Percolation until effluent becomes 0.18% KCN.	20
Continued percolation with strong solution...	20
Displacing strong solution with weak.....	29
Displacing weak solution with water.....	13
Sluicing out the exhausted tailing.....	3
—	
Total time (4 days 1 hour).....	97

The solution from the gold-solution tanks enters the zinc or

extractor-boxes of which three receive the strong and two the weak solution. Fig. 74 gives a plan and elevation of a zinc-box, and Fig. 75 a perspective view.

As shown, each set of boxes contains seven compartments, each 12 by 15 by 24 inches in size. The compartments have perforated false-bottoms of sheet-iron or wire-cloth that sustain the zinc-shaving with which they are filled. The partitions are set alternately up and down, to compel an upward flow of the gold-bearing solution through the shaving, and to bring it intimately in contact with the zinc to insure the precipitation of the gold upon the surface of the zinc. At *a* in the side elevation (Fig. 74) the solution enters the box through a pipe indicated at the left, passes through all the compartments, flows over the last partition, and discharges through a down-turned pipe into the sump-tank. The boxes are set at a grade of $\frac{1}{4}$ in. to the foot.

Precipitation.—The strong and weak solutions, leaving the leaching vats, are gathered in the respective gold-tanks. These

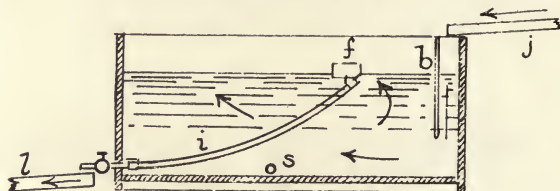

Fig. 76. FLOATING HOSE FOR GOLD SOLUTION TANK.

tanks accumulate the gold-bearing solutions from the leaching-vats, and provide a uniform discharge into the zinc-boxes. Since the solutions contain a little flocculent precipitate, which if allowed to enter the zinc-boxes would seriously interfere with the precipitation of the gold on the zinc, they are allowed to settle while the clear supernatant solution is drawn from the tank by a 2-in. floating hose, as shown in Fig. 76. This hose is attached, at its free end, to a float *f*, which may be a 5-gal. oil-can painted with asphalt paint. The high end of the hose is thus sustained slightly below the surface. The solution enters behind a partition *b*, so that it deposits its sediment at the bottom of the tank. The accumulated sediment is occasionally drained from the tank through the plug-opening *s* close to the bottom. Solutions pass through the zinc-boxes in a regulated flow into the sumps, the gold being precipitated on the zinc-shaving, which permits the free passage of the solution.

Zinc shaving is either bought prepared, or preferably is made at

the works. When freshly made, it is more efficient. To make it, a sheet of zinc is wound around a mandrel in a lathe, and the edge of the sheet is soldered down. A side-cutting tool is used to cut the shavings which are $\frac{1}{1200}$ in. thick, $\frac{1}{32}$ in. wide, and several feet long.

All the compartments of the zinc-box, except the last, are compactly but uniformly filled with the shaving, the last compartment serving as a settling box. Strong solution flows through the three strong-solution zinc-boxes at the rate of one ton per hour.

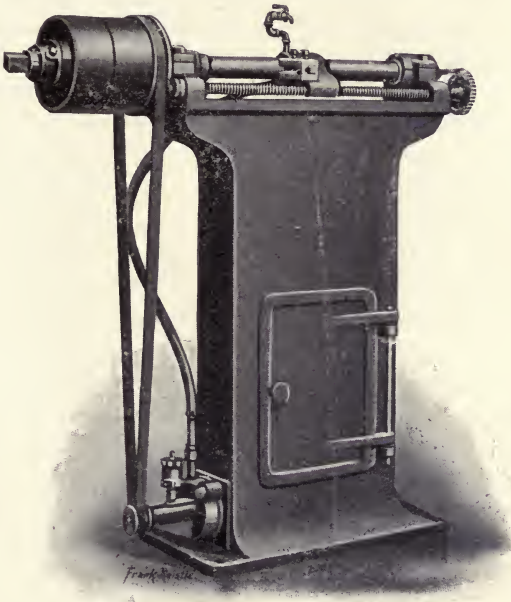

Fig. 77. ZINC LATHE.

The gold precipitates chiefly in the compartments first traversed, so that, by the time the solution reaches the seventh one, no discoloration of the shaving is to be noticed, and the barren-solution can go to the sump-tank *l*. The deposit on the zinc has a brownish, then a grayish-black hue. As it increases in quantity, the shaving in the first compartment becomes soft and stringy, and both precipitate and small pieces of the zinc settle through the screen to the bottom of the compartment. As the shaving in the first compartment settles down it is usual to replenish it with zinc from the last compartments, which in turn are filled with fresh shaving.

Before putting the shaving into the boxes it is usual to dip it

in a solution of lead acetate. Lead deposits as a film on the shaving, forming a zinc-lead couple that is more active than the zinc. Where copper is present in the solution selective precipitation is practised. This consists in running into it, just before it enters the zinc-boxes, fresh cyanide solution to raise its grade. In this way copper is held in solution, less of it precipitating upon the shaving. From 95 to 99% of the gold precipitates on the zinc. Since the barren solution is pumped back to the stock-tanks, the residual gold is not lost.

The weak solution, passing through the two boxes *k' k'* Fig. 66 in series, deposits the gold with more difficulty and less completely than the strong. The solution goes through the first box, then the second, or through 14 compartments in all, to precipitate as much of the gold as possible. It then flows into the tank *l*.

The clean-up.—This is made monthly or bi-monthly, according to the bulk of the precipitate to be treated, and the need of realizing values for operating expenses.

At the time of the clean-up, only one zinc-box is taken care of at a time, the flow continuing in the other boxes. The flow of gold solution to this box is stopped, and water is run in to displace the solution contained. Beginning in the first compartment, the shaving is agitated in the water for five minutes with the hands protected by rubber gloves. This is not done roughly, for the brittle shaving would be unnecessarily broken and the water would be black with the floating precipitate. The plug in the side (see *k* in the cross-section Fig. 74) is gradually withdrawn, and the accumulated slime and water allowed to flow into the launder *h*. The double line at the side of the zinc boxes, in Fig. 66, shows this launder. It connects by a cross-launder *n* and a main one *m* to the acid tank *o*, 6 ft. diam. The plug is replaced and the compartment is again filled with water. The zinc again is rinsed and rubbed, and the loosened precipitate once more drawn off. About three such washes free the shaving from precipitate and short-zinc. The compartments are thus successively cleaned up, and the shaving from each compartment successively is moved toward the head, and in the last compartment, where needed, replaced by fresh shaving. Finally, the launder is cleaned with a hose, and everything washed into the acid-tank *o*.

When all the boxes have been cleaned, the precipitate is allowed to settle a short time in the acid-tank and the supernatant liquid is syphoned into the 8-ft. settling tank *p*. In this larger tank the particles of precipitate have opportunity to settle, and to be recovered subsequently in the filter-press. The acid-tank is stirred

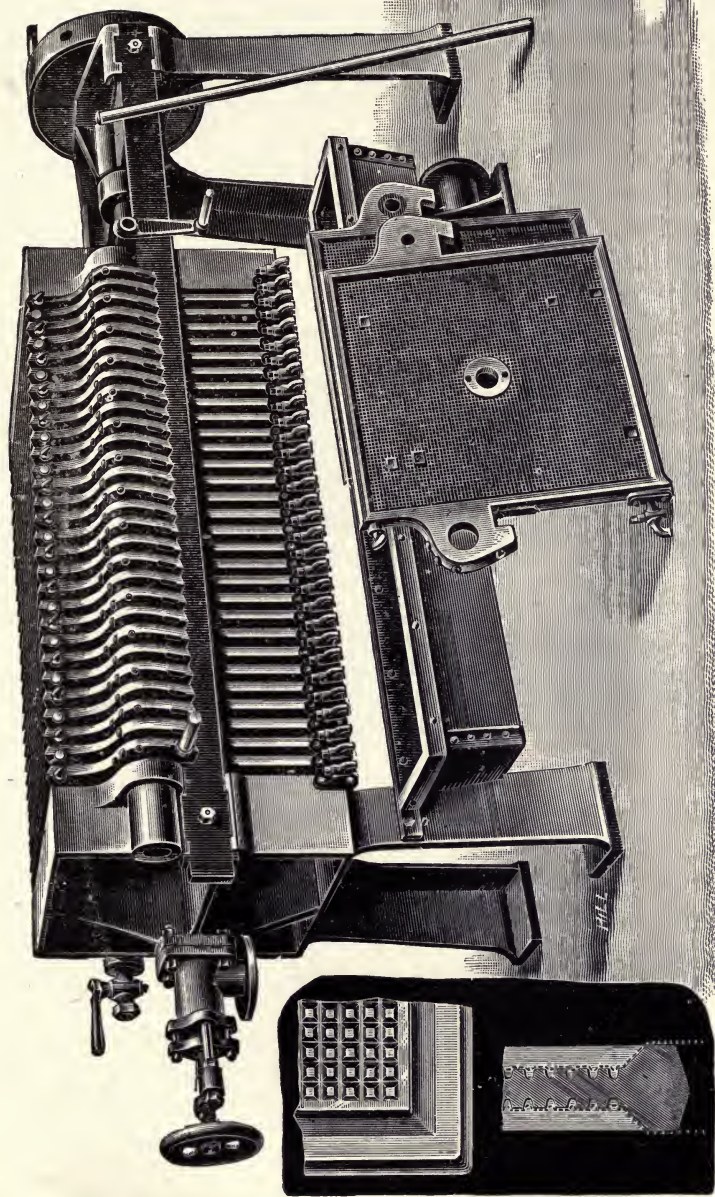

FIG. 78. FILTER PRESS.

by hand with a wooden hoe, or preferably a power-driven agitator in constant motion. This insures a thorough agitation of the sludge and precipitated in the acid-treatment now to be described.

The acid treatment.—Upon the watery slime about 30 lb. of sulphuric acid is poured. This acts upon the short-zinc and produces a violent effervescence. After subsidence the whole is stirred. When again the action abates, 15 lb. hot water and the same amount of acid is added with occasional stirring. This is repeated until further addition of acid produces little effervescence. Then the mixture is allowed to stand two hours, and a portion is tested with more acid to see that decomposition is complete. The total time for the operation is four to six hours.

Filter-pressing.—The black mixture, containing zinc sulphate in solution, is diluted with hot water to within a few inches of the top of the tank. The whole content is stirred and then pumped through the filter-press *r* Fig. 66. The tank is washed and the washings also are pumped through the press. Finally the residue in the press is washed with hot water to entirely remove the zinc sulphate.

Fig. 78 represents the filter-press used. It consists of a series of flat cast-iron frames 18 in. square. The frames are recessed, and between them are held canvas filter-cloths when in position for filtering. At the left-hand corner of the illustration, a dotted line on the cross-section of the frame indicates how the filter-cloth rests against the filter-frame. The filter-cloths, for use, are covered with filter-paper, so that the precipitate does not touch the cloth. This paper is burned after use, and the ash is mixed with the precipitate. The slime from the pulp enters the press under pressure through a pipe and valve, as shown at the left. The filtrate escapes by a row of bronze cocks, one on each frame, into a launder, and thence flows to the settling tank *p* Fig. 66. Leaning against the launder are to be seen two of the filter-frames. These show the grooved surfaces along which the liquid, after passing through the filter-cloth, reaches the outlet hole drilled parallel with the frame and leading to the bronze cocks. In case a filter-cloth breaks, so that pulp begins to issue from any cock, this can be shut off. The mixture enters through the centers of the plates and distributes itself sideways into the recesses between the filter-cloths.

The entire precipitate, having been transferred to the press, while in this position is washed with water under pressure. The water is followed by compressed air to dry the precipitate, which,

after this, is ready to discharge. To discharge the press, the tightening-screw at the right is slackened; the follower is drawn back, the frames are successively separated. The grayish-black residue in the recesses of the frame containing 20% or less of water, drops into a drying-pan placed beneath the press to receive it.

Drying and final treatment of the precipitate.—The product, still damp, is transferred to pans 44 by 24 in. by 4 in. deep. A pan is slid into a cast-iron muffle and heated until the precipitate is dry and then heated to an incipient red. It is then removed, allowed to cool, and the weighed contents cautiously mixed with half its weight of a flux composed of 4 parts borax, 2 parts soda, and 1 part sand. At the Standard plant, Bodie, where these

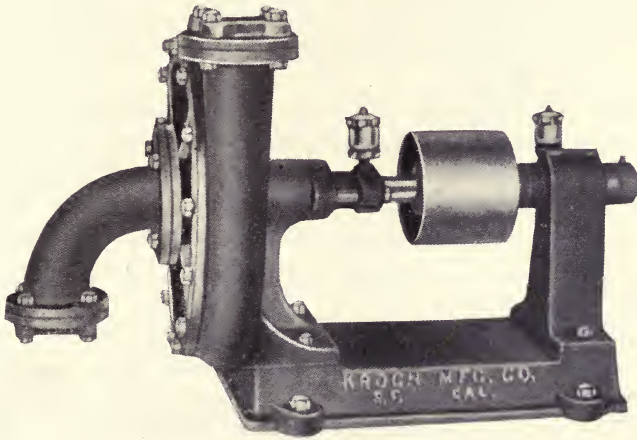

Fig. 79. CENTRIFUGAL PUMP.

proportions are used, the precipitate contains 6% silver and 9.5% gold. A clean and fusible slag is obtained by the use of the flux. Since the product is light and dusty, care must be taken in handling it, and for fusing, it must be put cautiously into the No. 60 plumbago (3-gal.) crucible. The melting is performed in the furnace shown at the right in Fig. 106.

The crucibles are placed in a wind-furnace and packed in coke. The melting is done as described under silver milling. The molten metal is stirred in the crucible, then poured into conical molds; and on cooling, the slag is removed and the gold remelted into an ingot.

At *v* Fig 66 is a vacuum pump by which air and solution are withdrawn from beneath the filter-bottoms of the leaching-tanks

through the pipes, *e*, *e*, and discharged by the pipe *u* to the stock-tanks *a* and *a'*. The solution that has lost strength by mixing with weak solution or water is increased to standard strength in the stock-tank.

The position of the engine which drives the overhead line-shaft is indicated by *g* in Fig 66, while *w* Fig. 65 is the position of the centrifugal pump driven from the same shaft by which solution from the sumps *l* and *l'* is returned to the stock-tanks *a* and *a'*. Fig. 79 is a view of such a pump. The solution enters through the elbow at the left and delivers from the discharge at the top. The pump has no inside valves to get out of order, and can be run at a velocity of 500 or more revolutions per minute.

A complete plant.—Fig. 80 is an elevation and Fig. 81 a view of a plant for the treatment of ore by the first method directly from the mine. This has been designed by the Allis-Chalmers Co., Milwaukee, Wisconsin.

As shown in Fig. 81, the buildings include a storage-building for the ore-bin, a coarse-crushing and drying-room, and a fine-crushing building, all of which are for the crushing plant and the preparation of the ore. The building used for the cyanide plant is the largest of all, and adjoining it, shown in the foreground, is the power house. At the right, and in front of the cyanide plant, the tailing-dump is indicated.

The ore from the mine enters at a high level and is discharged into the ore-bin *a* Fig. 80. From the bin it is withdrawn through a gate to a pile on the floor near the mouth of the Gates crusher, size 2. The entire ore, including fine and coarse, is regularly shoveled into the crusher, and broken to 1-in. size, the operation being confined to the 10-hour day-shift. Since we desire to crush ore into a product as granular as possible that it all may be leached, dry crushing is here practised. The finer crushing is preceded by drying the ore in order that it may be screened during the crushing. It is accordingly passed through a cylindrical dryer *c* 18 ft. long with ends 36 and 44 in. diam. respectively. From the dryer, the ore goes to a special fine crusher *H*, where it is reduced to $\frac{1}{4}$ -in. size. This discharges into an elevator *d*, which carries it to an inclined double shaking-screen, so arranged that the ore-stream may be diverted to either screen, thus guarding against loss of time in case of accident or repairs. This screen is simple in action, and low in first cost, and it easily treats the desired quantity (5 tons per hour) screening it to 8-mesh size. The over-size of the screen slides back to the special fine crusher,

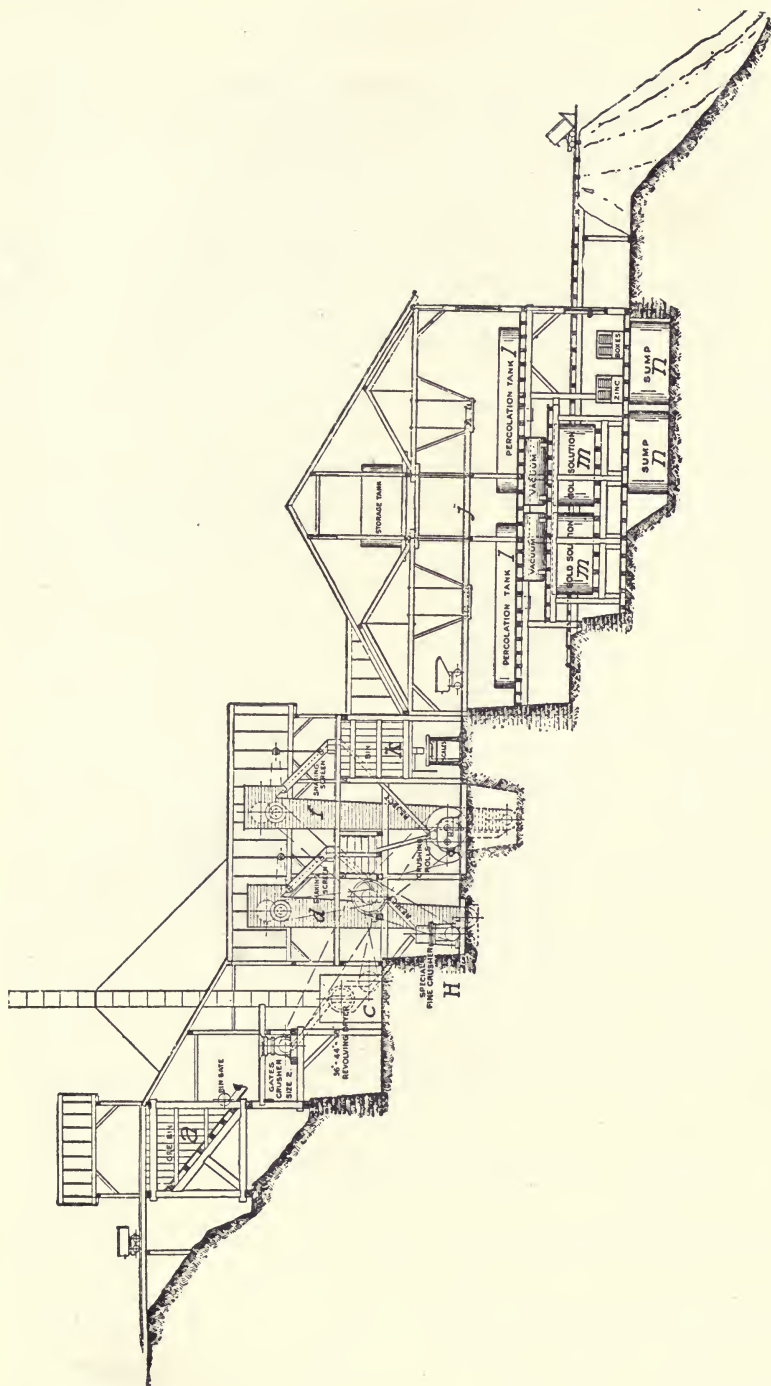

FIG. 80. ELEVATION OF FIFTY-TON CYANIDE PLANT.

while the under-size goes to crushing rolls set for fine crushing. The product from the rolls is raised by the elevator *f* to another double 30-mesh shaking-screen, the reject from which passes back to the rolls, while the under-size goes to a storage bin *k*. It will be noticed that in this system there is no automatic feeding of ore, and no storage after coarse-crushing. Simplicity is obtained by the use of a fine crusher in place of rolls, and by the use of the inclined screen. On the other hand, the system requires the more costly side-hill site, and at the same time, does not escape the need of elevators.

The product when crushed is drawn from the bin into scoop-cars standing on platform scales; and the content of each car is weighed. A suspended tract *j*, with turn-tables and tracks at right angles, is constructed over the leaching or percolating-vats, *l, l*, by means of which the cars may be dumped directly into the



Fig. 81. VIEW OF FIFTY-TON CYANIDE PLANT.

vats, the ore being leveled with a hoe. There are six leaching-vats, each of a capacity of 50 tons, for a six-day-cycle treatment each vat being 24 ft. diam. by 3 ft. deep.

Instead of dumping the ore directly into the vat from a height, which would tend to pack it in spots, the better way proposed is to have a hopper centrally placed over each tank just below the

track-level. An adjustable spout leads from this. By it the ore from the hopper may be more gently directed to any part of the vat, and kept in a looser, open, and uniform condition for leaching.

The strong and weak-solution stock-tanks are situated at the top of the building, and supply solution to the leaching vats for ore treatment. There are two vacuum-tanks used in connection with the vacuum-pump. Upon connecting them to the leaching-vats by a pipe that enters below the false-bottom, the operation of percolation is hastened, especially toward the last, when the ore becomes settled and compacted after the washes. When the vacuum-tank is filled, the solution is stopped and the tank is discharged into

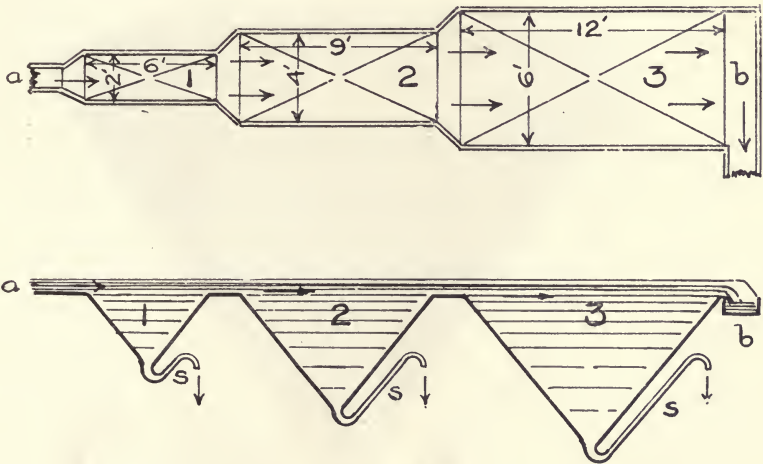

Fig. 82. THREE-COMPARTMENT SPITZKASTEN.

the gold-solution tanks m or m' . From these the solution flows through the zinc-boxes to the respective strong and weak-sumps n and n' . From the sumps the solutions are pumped back to the storage or stock-tanks above.

The tailing, still retaining some 16 to 18% water, is shoveled through bottom-discharge doors into tram-cars and run to the tailing dump. The treatment of the zinc-box precipitate has been described.

41. CLASSIFIERS AND SETTLING TANKS.

Sand and slime, mixed and in suspension in water as in ore pulp, may be separated under free-settling conditions by devices called classifiers. The pulp passes through the classifiers, from the entrance to the discharge in a current, and the heavier and

larger particles (the sand) separate by gravity, while the finer portion (the slime), still in suspension, passes out through the overflow with the water. The products are therefore termed the 'overflow' and the 'under-flow,' or spigot-discharge. Some of these classifiers have a supply of water, 'hydraulic water', rising from below, just sufficient to keep the slime in suspension until it escapes in the overflow, while the sand settles against the rising current and escapes in the spigot-discharge.

Of the classifiers that do not require hydraulic water we here enumerate two kinds: spitzkasten, and classifying cones.

Fig. 82 shows, in plan and sectional elevation, a three-



FIG. 83. CALLOW CLASSIFYING CONE.

compartment spitzkasten. The current enters by a launder at *a*, and traverses the three compartments successively, the overflow escaping by the launder *b*. The current widens, and as it enters each larger compartment, flows more slowly, and drops successively the finer sand. The sand, as it settles, escapes by the bent pipes *s* called goosenecks. Raising thus the end of the pipe diminishes the velocity of the outflow, and less water escapes with the sand. We get three sizes or grades of sand from the apparatus shown: the coarse from compartment 1, medium from compartment 2, and the fine from compartment 3. In cyaniding where it is sought to

obtain only two products, a single compartment in a classifier suffices.

Fig. 83 is a perspective view of a Callow classifying-cone, operating on the principle of the spitzkasten. The flowing pulp enters by launder to the center of the cone where it is received into a short, vertical, 12-in. cylinder. This deflects the flow vertically downward. Rising again, it overflows evenly around the rim, and being caught in the circular launder at the rim, flows away by the spout shown at the front. The gooseneck coming from the

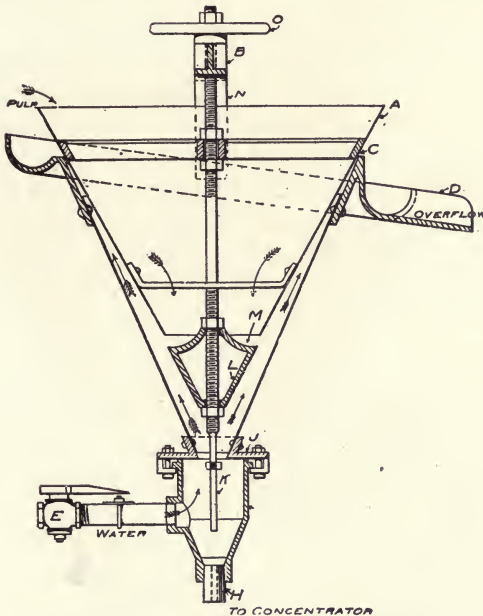

Fig. 84. DOUBLE-CONE CLASSIFIER.

apex of the cone is extended into a rubber hose. The end can be adjusted to alter the pressure of the outflowing sand-pulp. The pipe is provided with a side valve, through which water can be forced and an outlet at the apex, to clear it when choked.

Of the classifiers using hydraulic water, Fig. 84 is an example. It is a double sheet-metal cone with a cast-iron sorting-chamber *K* against an upward current of water admitted at *E*, and escaping by the spigot at *H*. The slime and fine sand, flowing downward to *M* are deflected by the adjustable cone *L*, caught by the rising water-current, and carried upward between the cones, escaping over the edge of the outer cone at the level *C*. The overflow is

caught in the circular launder and escapes by the spout *D*. The cast-iron cone *L* is adjusted by the hand-wheel *O*.

Sometimes the inner cone is omitted. The apparatus then becomes a settling-cone with a rising current of water. These are not really satisfactory in their action. Hydraulic water, rising through a sorting-column that enlarges rapidly in sectional area decreases in velocity. If the current enters the classifier in a horizontal stream, the heavier grains settle out and light ones overflow. Heavy grains escape in the sorting column, on the steep sides of the cone and from a bank there. Occasionally the bank falls in a mass into the spigot-discharge where it does not belong, or remains and hinders the action of the apparatus. To obviate this defect the sides of the cone should incline 55° at least. If a pointed box is used instead of a cone, the bank is apt to form at the corners. The cone, being made of metal, has smooth sides and no corners for a bank to begin to form. In a plain cone, using hydraulic water, it is better to use a pulsating current. This descends to the bottom, breaks up the bank, and agitates the pulp, but the expedient has the drawback that slime enters the spigot-discharge with the sand.

42. SECOND METHOD OF CYANIDATION.

Where the ore carries gold and pyrite, a stamp-mill, such as shown in Fig. 44, is employed. The coarse gold is recovered by passing the crushed pulp from the battery over amalgamated plates, and the heavy sulphide (principally pyrite) is removed by concentration on Frue vanners or other concentrating tables. The tailing from the mill is classified into sand and slime. The sand is treated by leaching as in the first method, and the slime by one of three methods: (a) Decantation. (b) Filter-pressing. (c) Suction-filtration.

The plant, for the cyanidation of tailing is called the cyanide plant; and this may be divided into a sand-plant and a slime plant. When a stamp-mill is provided with an added building for treating tailing by cyaniding, such an addition is called a cyanide-annex.

Plant using decantation.—The practice in South Africa today has been brought to a high state of development. At first, ores containing \$9 gold per ton were milled by wet-stamping and amalgamating. The free coarse gold was recovered, but the tailing, still containing \$3.50 per ton, was accumulated in extensive deposits and retained behind dams. Cyanidation was first applied on the accumulated tailing which was shoveled into cars and hauled up

inclined tramways to large leaching tanks. This practice, so long as the impounded tailing lasted, was comparatively simple; but, when the reserve was exhausted it was necessary to devise a method for treating tailing as it came from the mill.

Fig. 85 is a diagram illustrating how this is done. The tailing from the stamps, having a value of \$9.60 per ton, is neutralized with milk of lime at the launder *a*, and enters the receiving tank *b*, where it is kept agitated by a 4-arm stirrer mounted on a vertical shaft. A centrifugal pump forces it by the pipe *c*, to the pointed-box classifier *d*, which takes out a mixture containing about 10% coarse sand and \$25 per ton concentrate, this being delivered to the tank *g* by a distributor *f*. This is shown more clearly in the

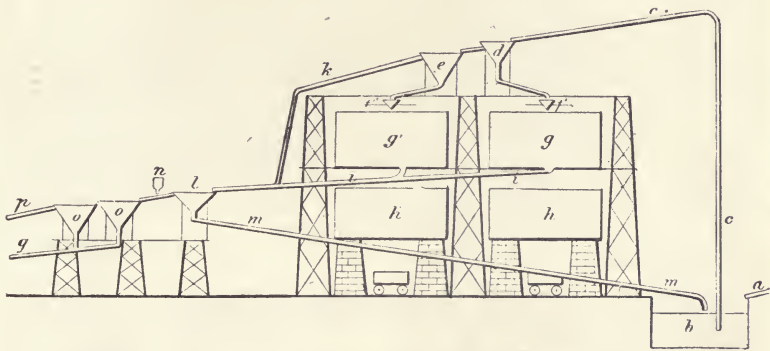

Fig. 85. CYANIDE PLANT FOR DOUBLE TREATMENT.

illustration of another plant, Fig. 86, where, in the foreground, is a settling tank arranged with a Butters distributor. This is a horizontally revolving device supported by a vertical shaft on which the distributor revolves. The pulp from the classifier is carried in a launder, shown at the right, to the central hopper of the distributor from which radial pipes discharge the pulp into the vat. Each pipe is bent at the end so that the reaction of the escaping pulp sets the distributor in revolution. Owing to the varying lengths, the pipes evenly distribute the sand in the vat. Water and slime, floating above the sand, are withdrawn through four vertical gratings set equidistant on the sides of the tank. One of these gratings can be seen at the edge of the first tank in Fig. 86. As the tank fills with sand, a roller, carrying a narrow canvas curtain, is unrolled to the level of the deposited material. Another method of removing slime and water consists in entirely filling the

tank with water, and letting the sand drop through it, the surplus of slime and water overflowing into the encircling launder.

The overflow from *d*, Fig. 85, containing \$7.90 per ton, goes to the classifier *e*, which removes a portion, amounting to 65% of the whole, that has an average value of \$9 per ton. This clean and finer sand is distributed in the tank *g'*, while the overflow from the classifier goes by the pipe *k* to classifier *l*. The overflow from settling tanks *g* and *g'* also flows into the classifier *l*. The object of the classifier is to take out the little sand that escapes settling

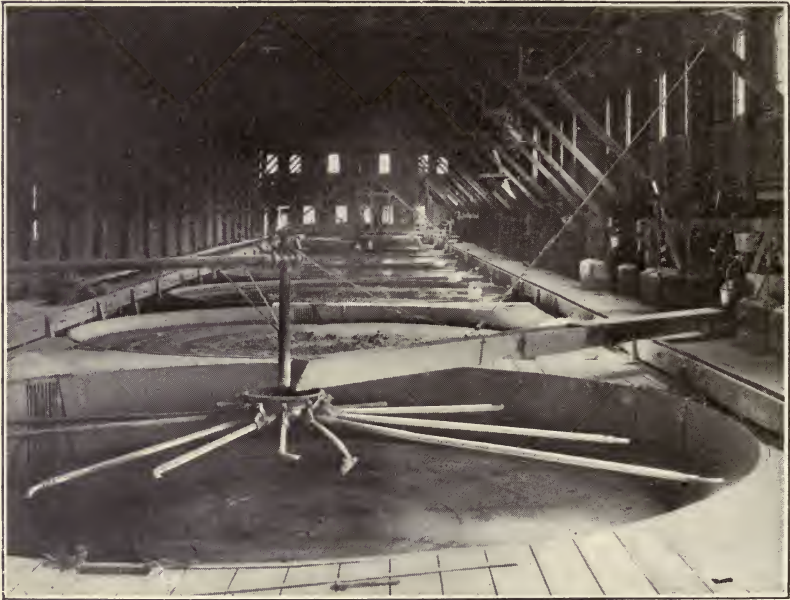

Fig. 86. TANKS AND BUTTERS DISTRIBUTOR.

previously. The amount is small and it is returned by the pipe *m* which leads back to the receiving tank *b*, and caused once more to go through the system. The overflow from *l*, consisting only of suspended slime, 25% the weight of the ore crushed, and having a value of \$5 per ton, is treated with additional milk of lime from an automatic feeder *n*. The addition of the lime is for the purpose of hastening the settling of the slime that flows through *q* to settling tanks, while the clarified supernatant water escapes at *p*, and is returned to the battery.

Assuming that the tank *g*, which holds 114 tons, has been

filled with the mixture of coarse sand and concentrate, and has been drained, it receives 10 tons of weak solution (0.03% KCN). After this the ore is drained and transferred to the lower tank, this part of the treatment occupying five days. The advantages of making the transfer are two-fold: first, that the imperfectly packed portion becomes mixed with the other sand, and second, that the material, thus moistened with cyanide solution, is exposed to the oxygen of the air during transfer. In the lower vat the charge receives 50 tons of strong solution (0.2% KCN), followed by 75 tons of medium, and 65 tons of weak solution. It is then drained and discharged. This takes twelve days more, or seventeen days for the whole treatment.

The fine sand in *g'* requires less time for treatment than the coarse. It receives 10 tons of weak solution and 20 tons of medium solution. It is then treated with 50 tons of strong solution, 20 of medium, and 20 of weak. The time is three days for the upper, and five days for the lower vat.

The Blaisdell excavator.—In place of shoveling the contents of the upper vat into the lower one, an operation which by no means breaks up the lumpy ore, the Blaisdell system for transferring and distributing has been devised. Fig. 87a represents the excavator. It consists of a trussed steel-bridge, supporting at its center a vertical steel shaft with four horizontal arms below, called excavator beams. This bridge travels on rails and may be set over any vat. The central vertical portion of the bridge carries guides and screws for raising or lowering the shaft and arms. The arms carry steel harrow-disks.

In operation, the central door or trap at the bottom of the vat is opened and a hole is quickly dug down to it through which the sand may fall. The excavator is now placed in position and the shaft and arms, having been put in motion by an independent motor, the steel disks pass over the surface of the sand, cut it, and roll it toward the center where it falls down through the trap. The shaft is gradually lowered as the cutting proceeds, much as an auger would advance in boring a hole, until the vat is emptied. The arms are then raised and the excavator moved to another vat.

The excavated sand from the settling tank falls upon a belt-conveyor which carries it to the leaching vat. When it reaches the vat a distributing machine or distributor, shown in Fig. 87b, that consists of a movable steel bridge supporting a conveyor-

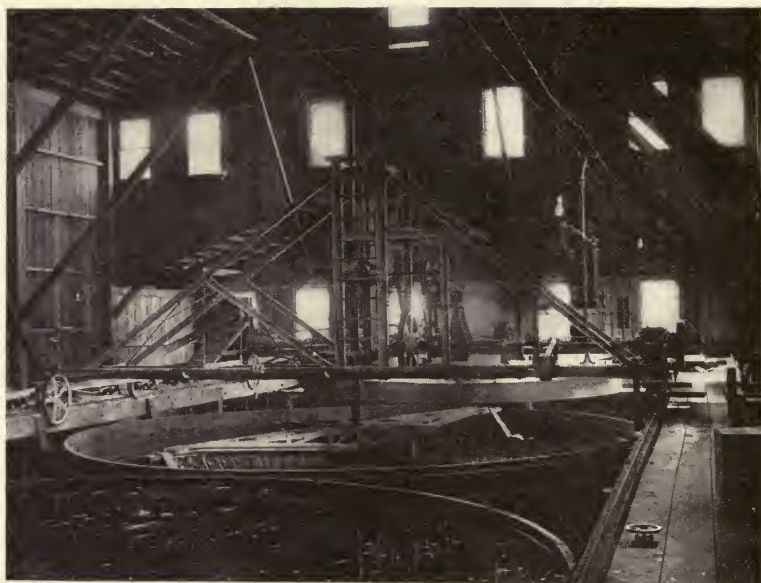

Fig. 87a. BLAISDELL EXCAVATOR.



Fig. 87b. SAND DISTRIBUTOR, BLAISDELL SYSTEM.

belt, takes the sand from a tripper and drops it into a hopper at the center of the bridge. It falls from the hopper upon a rapidly revolving steel plate which breaks lumps and distributes the sand lightly and evenly in the vat in an ideal condition for rapid and uniform leaching. The large circular band or ring, suspended from the bridge, is to prevent throwing the sand too far.

(a) **Decantation.**—The slime coming from the pipe *g*, Fig. 85 is collected in large settling tanks. Each tank when filled is cut out from the flow, and allowed to settle. After settling, the supernatant water is drawn off by the decanting device, Fig. 76. This removes the surface water continuously. A weak solution (0.1% KCN) is then added to the slime in the settling tank, and agitation effected with mechanical stirrers, or by transferring the pulp from one tank to another with a centrifugal pump. After several hours the solution is allowed to settle, then drawn off by decantation. More cyanide is then added, the whole stirred, allowed to settle, and half the solution again withdrawn. The operation is repeated several times, the final wash being of water. In this way 75% of the gold in the slime is extracted.

The various cyanide solutions mentioned above are run through the zinc precipitating boxes, the zinc-shaving having first been prepared by dipping it in a solution of lead acetate. The zinc becomes covered with a film of lead forming a zinc-lead couple, and is more active in depositing gold than zinc alone would be.

The objections to this method of slime treatment, are: the large and awkward plant required, and the loss due to the impossibility of saving the last traces of dissolved gold. These were soon recognized by metallurgists in Western Australia, and the following method was devised:

(b) **The filter-press method of slime treatment.**—This consists in agitating the cyanide containing slime-pulp (in a settling tank) and removing this solution containing the gold, by forcing the material under a high pressure into a filter-press, Fig. 78. The solution retained in the slime-cake is displaced by forcing dilute solution, or water, through the press. The comparatively dry compressed cake of slime containing 20 to 25% water, is dropped into a car beneath and trammed to the dump. The filtered solution goes to the gold-solution tank, and thence through the zinc boxes, to the proper sump. An estimate of the cost of this kind of filter-pressing is 38c. per ton.

(c) **Suction filtration.**—With the exception of the system used

at the Homestake slime plant, the comparatively high cost of filter-pressing and the heavy cost of installation has led to the adoption, in the United States, of various systems of vacuum filter-pressing of which the Butters filter, Fig. 88, is an example.

The Butters solution-filter.—The white rectangular object, at the center, in the background of the illustration, is a cluster of four filter-leaves suspended from an over-head crawl. These have just been hoisted out of the tank below. A single leaf is 10 ft. long by 5 ft. high. The upper part of the frame of the leaf is



Fig. 88. BUTTERS FILTER TANKS.

a wooden bar, sufficiently long to span the tank and rest upon the sides. The remaining three edges of the frame are of iron pipe. The filter-leaf consists of a piece of cocoa-matting cut to exactly fit the frame, and this is covered on each side by a sheet of canvas. These three sheets of material are sewed together, and the whole fitted round and fastened to the frame. Five vertical strips bolted on the outside serve to stiffen the frame. Fig. 88 gives a view of two 60-frame filter-tanks which, in Fig. 89 and 90 are marked *E, E*.

Fig. 89 is an elevation and Fig. 90 a plan of a 120-frame Butters vacuum-filter plant. The slime is in cyanide solution several hours, or until the gold is dissolved. For convenience the pulp is collected in a tank *A*, called the pulp-storage tank, and from there is run, as desired, into one of the filter-tanks *E, E*, filling it to the tops of the frames. It will be noticed in Fig. 88 that the pipes of the

frames are connected to a common header. This header leads to a vacuum pump *N*. Upon starting the pump, the solution is sucked through the filter-frames, discharging into a gold-solution tank outside the building. Pulp is run into the box at intervals to keep

Fig. 89. GENERAL ELEVATION OF BUTTERS FILTER PLANT.

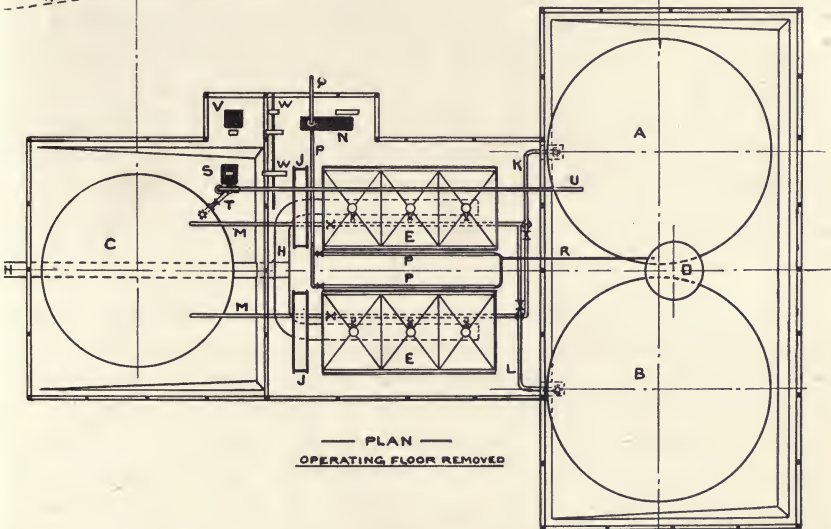
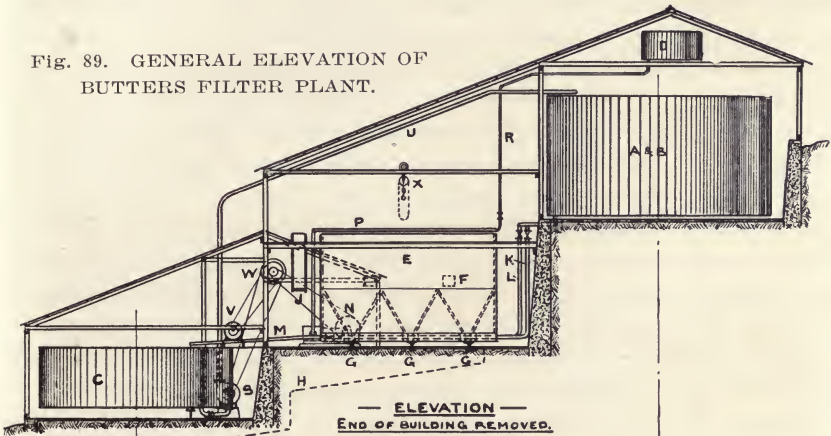

Fig. 90. GROUND PLAN OF BUTTERS FILTER PLANT.

the filter-leaves submerged. The slime remains as a cake on the outside of the filter-leaves, and forms a deposit sometimes nearly an inch in thickness.

When the cake is formed the supply of pulp is shut off, and the surplus pulp run to the tank *C* and pumped back to *A*. A weak

cyanide solution from tank *B* is next admitted to the filter-tank, and is sucked through the cake to displace any gold solution remaining, the level being maintained as before. The surplus wash-solution is pumped back to *B*. In the same manner the cake is washed with clear water to displace the last of the cyanide solution. Both washes go to a weak gold-solution tank near *Q*. While the tank is being emptied and filled and the cake is exposed to the air, the vacuum must be reduced to 5 in. to hold the cake firmly in place. The vacuum pump is now shut off, and air under a slight pressure is forced into the leaves, displacing or throwing off the cake, which drops to the bottom of the tank. The 12-in. quick-opening discharge gates, *G*, are opened, and the slime is washed out into a waste-laundry. The gates are again closed, and the filter is ready for a new charge. The formation of the slime-cake adjusts itself as the composition of the material varies at any point, the coarser forming a thicker layer than the finer, thus maintaining the even permeability. The time of washing is 15 minutes. The operation is conducted by one man. A precipitate of calcium carbonate gradually forms upon the leaves, decreasing their permeability, and every two to nine months this is dissolved by dipping the leaves in tanks *J* which contain a weak solution of hydrochloric acid. In Fig. 88, a set of leaves is shown in the process of transferring to the washing-tank. The operating cost for filtering, including labor, power, and repairs, in a large installation, amounts to 8c. per ton of slime treated.

43. CYANIDATION AT THE HOMESTAKE MILL, SOUTH DAKOTA.

The ore is a garnetiferous hornblende schist containing 7 to 8% pyrite and pyrrhotite. It is crushed with eight to ten times its weight of water, and amalgamated, using inside plates for the mortar, as well as outside amalgamated apron plates.

The pulp from the mill, some 1300 tons daily, is carried by laundry to a cone-house, Fig. 91, to a set of twelve settling cones that are 10 ft. diam. with sides having an angle of 50 degrees. The stream is distributed evenly to all, entering each at the center. Half the water and the finest slime is removed by the overflow. Some fine sand is carried over with slime, and this is separated by a series of settling tanks, the overflow running to a pond. Here the water has an excellent chance to settle, and when nearly clear, it is pumped back to be used again in the mill. The sediment accumulates in this pond and finally is washed out with a hose and

run to waste. From the bottom of the cones is withdrawn a thickened pulp containing the sand and some slime. This is carried by a 12-in. pipe on a $2\frac{1}{2}\%$ grade to the sand-plant, Fig. 92 and 93.

Classification at the plant is effected by means of six gravity settling cones *b*, 7 ft. diam. and with sides of a 50° slope. The underflow from each of these goes to four classifying cones *c*, 24 in all, which are 4 ft. diam., and with steep sides of 70 degrees. These are provided with hydraulic water, as in the lower cone of Fig. 99, by means of which the sand settles nearly free from slime. The slime from these cones, containing 90c. to \$1 per ton, and amounting to 40% of the total tailing, was formerly wasted, but more recently has been treated by filter-pressing, at the slime-plant to be described later.

The sand-plant.—The prepared sand contains 40.5% coarse particles that remain on a 100-mesh screen; 30.8% middles, between 100 and 200 mesh, and 28.7% fine passing 200 mesh. This leaches at the rate of 3 or 4 in. per hour. Before the sand enters the



Fig. 91. CONE CLASSIFIERS, HOMESTAKE MILL.

leaching vats it receives a stream of milk of lime which has been prepared by being stamped in a five-stamp battery reserved for the purpose. From 3 to 5 lb. of the lime are added per ton of sand. The classified pulp and lime thus mixed, pass to a Butters distributor, see Fig. 86, which can be transferred from one vat to another by an overhead trolley. There are 14 leaching-vats, each 44 ft. diam., 9 ft. deep, and capable of holding 610 tons. The tank is filled with water and the sand runs in. It takes 11 hours to charge the tank, and treatment lasts five days. When the tank is filled the ore is drained and a series of washes of the stronger of the stock solutions (containing 0.14% KCN) is run in, allowing each wash to drain below the top of the ore to draw in air. The effluent, its strength reduced to 0.10%, is run to the two weak-

solution precipitation tanks *f f*, Fig. 93, each 26 ft. diam. by 19 ft. deep. After this, the weak solution is brought upon the charge and retained two days more. The solution escaping during this period is run to the two strong-solution collecting tanks, *e e*. This is followed by a water wash which finally reduces the unextracted gold to 5 to 7c. per ton.

The charge is now ready for sluicing out. This is done by two men in four hours, four side gates and one bottom gate being

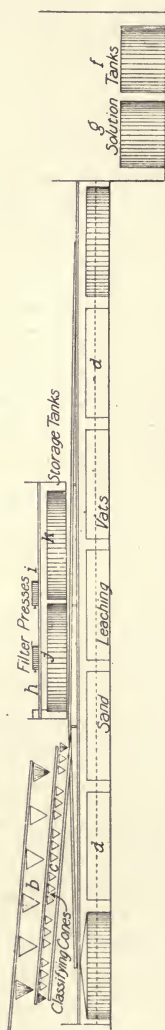

FIG. 92. ELEVATION OF SAND-PLANT, HOMESTAKE MILL.

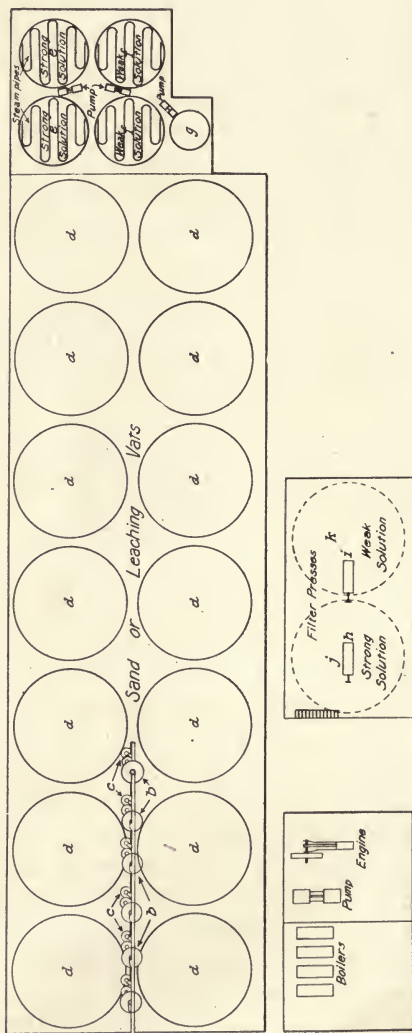

FIG. 93. PLAN OF SAND-PLANT, HOMESTAKE MILL.

used for the purpose. The 8-oz. duck filter-cloth underlaid with another of cocoa matting is washed clean. The vat is then filled with water and is ready for the next charging.

Precipitation.—The solution, resulting from the leaching with strong solution, run into one of the weak-solution tanks *f f*, contains \$2 gold per ton. When the tank is filled the stream is turned into the second tank, and the first is ready for precipitation. The tank holds 300 tons of solution that is agitated by compressed air admitted from a pipe across the bottom of the tank pierced with numerous small holes for the escape of the air. Sixty pounds of zinc powder in the form of an emulsion is sprayed in, during the agitation, and in 20 minutes the precipitation of the gold is complete. A duplex pump is now started and the mixture in the tank is pumped up to two large filter-presses, *h* and *i*, each containing 24 frames 36 in. square. The filter-cloths of the presses soon become coated with gold precipitate and zinc-powder, and every drop of solution passing through, comes into molecular contact with the zinc dust. The value of the solution is reduced from \$2 to 5 or 10c. per ton (a precipitation of 97.5 to 95.0%) and is then termed barren solution and passes to the weak-solution storage tanks *k*.

The weak-solution wash above referred to fills the strong-solution collecting-vats *e e* and is strengthened to 0.14% KCN and pumped directly, without prior precipitation, to the strong-solution storage tank *j*, from which it is drawn for the first treatment of the sand.

It is seen that the strong solution of one day becomes the weak solution of the next, and that all the gold accumulates in the weak-solution precipitation tanks. The strong solution has an approximately constant value. One-half the total effluent solution is precipitated, the other half having a nearly constant value of 30 to 50c. per ton.

The precipitate, containing gold and the fine zinc, accumulates in the filter-presses, that are run a month without opening. In this way about a ton of precipitate, worth \$50,000, is obtained. The presses are opened, the precipitate removed and sent to a lead-lined mixing tank that is equipped with a mechanical agitator, a hood, and an exhaust fan for removing acid fumes. Here it is treated with dilute hydrochloric acid to dissolve the zinc, agitated, and settled. The supernatant solution is then drawn off, by means a montejus or pressure-tank to another smaller filter-press. Sulphuric acid is next added in the mixing-tank and the mixture

is agitated and heated. Upon settling, the supernatant acid solution follows the first one through the press. Wash-water is next run into the tank and without further settling is run to the press. Finally the precipitate in the press is washed with clean water. The acid solutions and the wash-water go to a large settling tank that acts as a guard to recover any escaping particles.

The acid-treated precipitate is now transferred from the press to a large steam-dryer, where a part, but not all, of the moisture is removed. It is then mixed with litharge, borax, silica, and powdered coke and sprinkled with lead acetate solution, and briquetted in a press under a pressure of 2 to 3 tons per square inch. The briquettes are dried, charged into an English cupelling-furnace, see Fig. 179, and quietly fused, suffering no loss. The lead, as in assaying, absorbs the gold and sinks to the bottom, while the slag flows away as it forms. The 'test' gradually fills with lead, which is oxidized to litharge in cupellation, leaving a metal 975 to 985 fine in gold and silver, which is run into ingots. The litharge produced is reserved to be added to the precipitate at the next clean-up.

The cupel-slag, cupel-bottoms, sweepings, or other metal-bearing cleanings are accumulated, and occasionally run through a small silver-lead blast-furnace. There is produced a slag assaying less than \$5 per ton, and base-bullion which is returned to the cupel-furnace at the next clean-up. The method of treating the precipitate, it is claimed, is practised with a loss of only 0.1 per cent. The cost of treatment per ton of sand is 26c. This has been brought into comparison with South African costs that, before the Boer war, varied from 55 to 72c. per ton.

The slime-plant.—The slime pulp, amounting to 1600 tons daily, has an average value of 91c. per ton. It contains three tons of water to one ton of solid, and is carried two miles by a 12-in. pipe at a grade of 1.5% to the slime-plant. Here, two small vats are provided for slaking lime. The content is drawn to a screen-bottom box where the undissolved lumps separate. The box overflows into an agitator from which the milk of lime continuously runs into the main slime-stream at the rate of 5 lb. of lime per ton of dry slime. Two storage vats, 26 ft. diam. and 24 ft. deep, having conical bottoms with 47° sides, receive the stream. From the bottom of these storage vats the slime-pulp is drawn continuously through a 10-in. pipe to large filter-presses 65 ft. below to obtain a pressure of 30 lb. per sq. in. The 10-in. main extends the whole length of the press-building. Between each

pair of presses, the main branches into 10-in. pipes, which in turn send two 4-in. branches to each press. The smaller branches connect to a 4-in. passage or channel that extends along the center of the top of the filter-press frames. From the channel the slime-pulp flows into the press. There are 92 frames each 4 ft. by 6 ft. and 4-in. distance-frames to form slime-cakes 4 in. thick.

The press having been filled, a 0.1% solution of KCN is run in, entering at the lower corners of the press by two channels each 2.5. in. diam. Compressed air is admitted at the upper corners of the press by two channels each 2.5. in. diam. This is followed by a 0.04% KCN wash, another treatment with air, and again a water-wash, until the exhausted slime contains no more than 9 cents gold per ton. Along the center of the bottom of the frames is a continuous 6-in. channel, and within it a 3-in. pipe extending the length of the press. This pipe is provided with 92 nozzles 1 in. long and $\frac{5}{32}$ in. diam. By a special mechanism a revolving motion through 200 degrees is given to the pipe, so that under a water-pressure of 50 lb. per sq. in., the nozzles play against the compact slime-cakes, removing the cake completely from the compartments in 45 minutes, the 6-in. channel (generally closed) being then opened for the exit of the slimes. The operation, exclusive of the time of filling and emptying, occupies 6 hours. It will be noticed that the solution of the gold, and the extraction of the slime, is done entirely at one operation and within the press. The effluent solutions now flow to the strong and weak gold precipitation-vats where the gold is precipitated by means of zinc dust. Zinc-dust is a fine powder produced in retorting zinc ores and contains 90% Zn. An emulsion of this zinc in water is added to the solution in a conical-bottom tank. With an air-lift pump a thorough mixture of the zinc with the solution is obtained.

As at the sand-vats, the solutions are pumped to the storage solution-tanks and to the precipitate-presses, the treatment at this stage being the same as that already described as taking place at the sand-plant. The estimated cost of this plant is half a million dollars, and the cost of treatment, per ton of slime, is 25 cents including all items. The recovery is 90 per cent.

44. CYANIDATION AT EL ORO, MEXICO. (THIRD METHOD.)

The third method of cyaniding is well exemplified in the practice at El Oro, Mexico. The oxidized ore, a hard compact quartz, contains from \$6 to \$15 gold and 3 to 5 oz. silver per ton. The

gold is distributed so finely through the quartz that seldom can a 'color' or visible speck be discovered. The silver is partly metallic, and partly in the form of sulphide, arsenide, and antimonide. Both metals are considered to be deposited between the faces of the elementary quartz crystals. The necessity of fine grinding to unlock the gold and silver particles is well illustrated by Fig 94.

The mine-ore is dumped from skips at the shaft into ore-bins, coarsely crushed, and conveyed to the mill by cars. It is stamped through a 25-mesh screen, then goes over amalgamated plates which catch from 13 to 18% of the gold and 1 to 5% of the silver. The

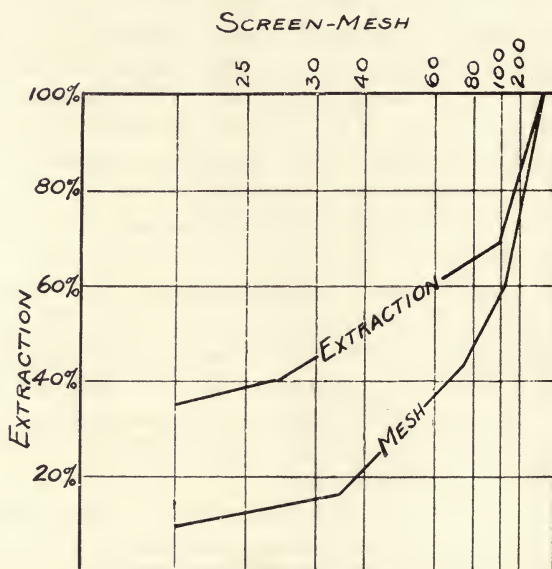

Fig. 94. RELATION BETWEEN MESH AND EXTRACTION.

pulp from the plates is re-ground through tube-mills, then flows to the cyanide plant where it is separated into sand and slime, these being treated separately. The daily duty per stamp is 4.7 tons, and the ratio of water to ore is as nine or ten to one.

Fig. 95 is a flow-sheet showing the method of treatment.

The ore pulp from the plates passes to two cones 4.5 ft. diam. beneath which, in series, are two 2-ft. cones called 'pulp thickeners.' The overflow from all the cones gives a product containing 81% slime, while the underflow or spigot discharge, a sand still retaining 9% slime, passes to the tube-mill No. 5, where half of it is ground to a slime.

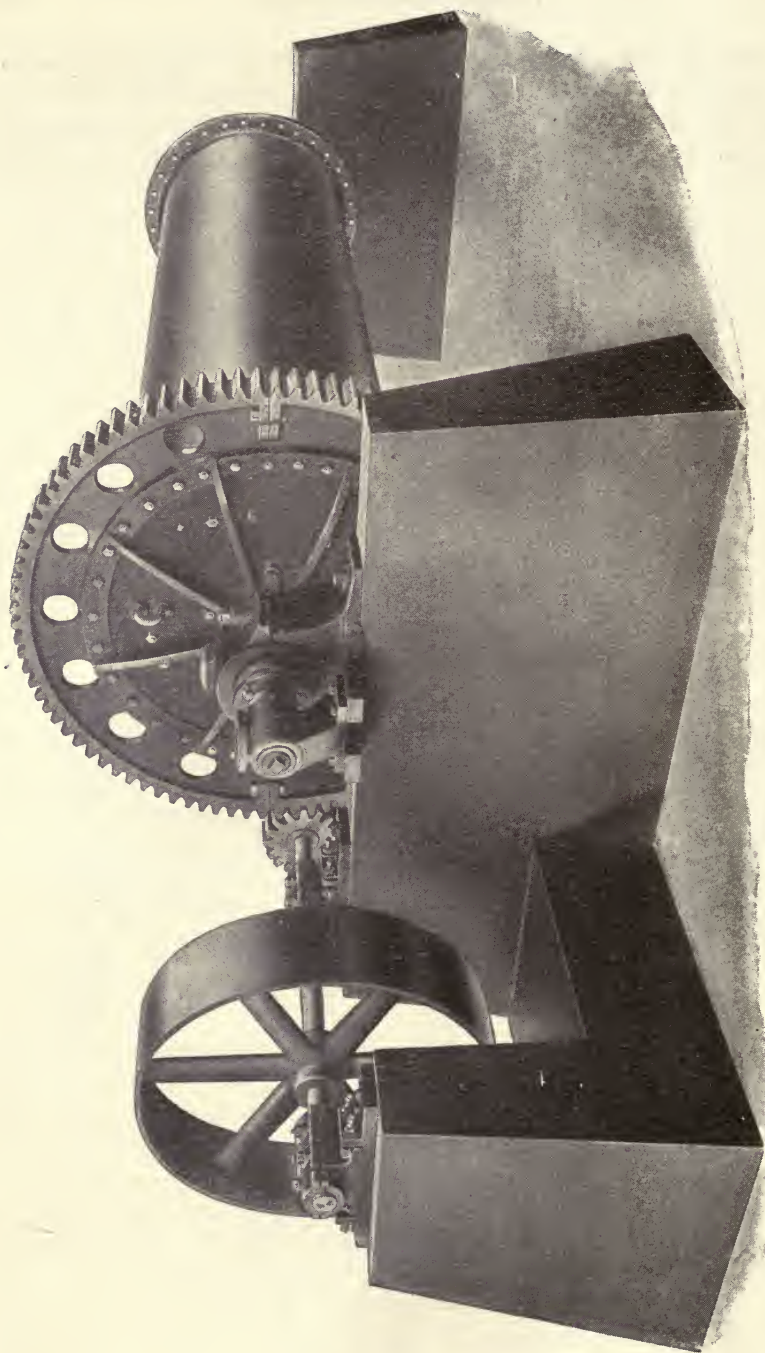

FIG. 96. GATES TUBE-MILL.

(a compact quartz) about the size of ordinary brick, and in operating is filled with hard quartz pebbles the size of the fist. As the barrel revolves, these pebbles, dropping back upon one another, finely grind any material fed to the mill. The ore is fed in from a hopper placed at one end. The ground pulp escapes through the perforated false head at the other end, and overflows through the other trunnion.

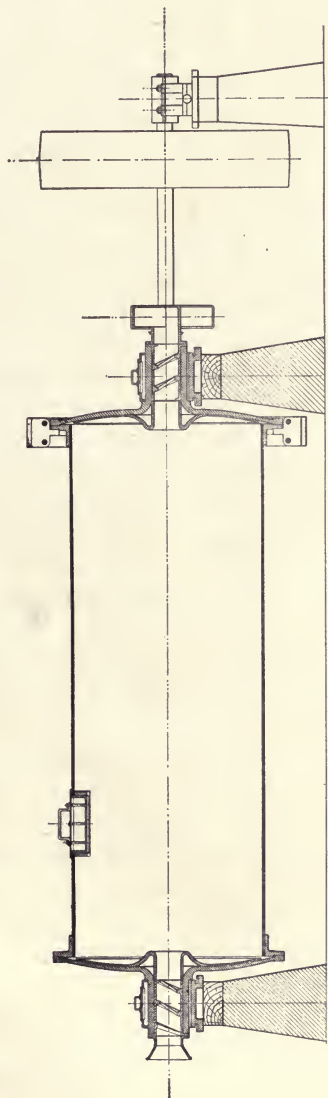

Fig. 97. ELEVATION OF TUBE-MILL.

Referring to Fig. 95, the discharge joins the overflow of the cones and goes to spitzkasten No. 1, which takes out the insufficiently ground sand. This is raised by the elevator wheel and sent to return cone No. 5 (the purpose of which is to remove the unground sand), then goes to tube-mills No. 3 and 4 for re-grinding and finally back to spitzkasten No. 1, while the fine-sand overflow of return cone No. 5 passes to one of the nine 'sand-receivers' over a Butters distributor. The overflow of these sand-receivers goes on to spitzkasten No. 2, which takes out a little fine sand which returns to the elevator wheel, and an overflow that joins the overflow from spitzkasten No. 1 and passes on to the 'slime tanks.'

Each sand receiver, when filled, is drained 24 hours, and without further preliminary treatment, is discharged by a Blaisdell excavator, see Fig. 87a, upon a belt-conveyor that takes it to one of the 12 treatment tanks to be charged by a Blaisdell distributor, see Fig. 87. In these tanks the sand is regularly leached.

The treatment consists in leaching the sand with a certain number of strong and medium solutions or washes, given alternately, and followed by a number of weak-solution washes. By these, the gold in the tailing is reduced to 20c. per ton, and the total time of leaching is 90 hours. The use of the sand-receivers to do the first part of the leaching has been discontinued because of the loss of time and cyanide solution, and because the tank becomes tightly packed and uneven. The aeration effected by excavating and redistributing the sand, has a great influence on the rate of extraction. This is helped by the speed at which the washes follow one another. The gold is more speedily extracted than the silver. Cyanide consumption is also rapid at first. Upon the completion of the treatment the tailing is removed by another Blaisdell excavator and by a troughed conveying-belt that takes it to the dump.

The slime-pulp, overflowing from spitzkasten No. 2 is composed of 1 part of slime to 12 of water. To cause the slime to settle readily, caustic lime is added to the mill-pulp (just before it enters the tube-mills) at the rate of 12 lb. lime per ton of ore. The slime-pulp flows continuously into one of the slime-tanks, 75 tons of slime settling in the bottom of the tank, while the clear supernatant portion overflows to the 'mill-water sumps,' whence it is pumped back for use in the mill. When a charge has been completed the slime is allowed to settle 8 hours, and the clear water decanted. The slime is now stirred by means of the mechanical agitator of the slime-tank. In ten minutes thereafter a

centrifugal pump is started by which the pulp is elevated and thrown back into the tank. The pulp having been thoroughly mixed, a specified amount of 0.05% cyanide solution as well as lead acetate (0.4 lb. per ton of slime) is added, and the whole agitated 7 hours. The tank is filled with fresh cyanide solution, the stirring is stopped, the content allowed to settle, and the solution decanted as closely as possible. Four additional washes are given as rapidly in succession as the settling of the slime will allow. The residual slime is then pumped into a slime-settler, is gradually settled, then decanted, and the discharge slime run to waste.

It will be seen that there are two of the gold-solution tanks, the 'strong' and the 'medium,' which take their supply from the sand-tanks, while a group of three (the weak-solution tanks) take their supply, not only from these, but from the slime-tanks as well. The final wash, which is decanted from the slime-settlers, contains but little gold and need not go through the zinc-boxes but instead, to the weak-solution sump-tanks. To aid precipitation, at the strong and medium zinc-boxes, a regulated flow of 2.5% KCN is added to the inflowing solution from the sand-plant. After this has passed the boxes, it is raised to its full strength by the addition of a concentrated solution of KCN contained in a 'dissolution tank' near the sumps. When pumped to the slime-tanks it is there strengthened by letting it run over a sack containing solid KCN salt. At the sides of both the slime tanks and the slime-settlers are swinging decanting pipes, which withdraw the upper portion of the clear supernatant solution.

45. CYANIDATION IN SOUTH DAKOTA (FOURTH METHOD).

An example of this method is found at the Maitland mill, Maitland, South Dakota. The ore is close-grained, hard, and in the main oxidized, through carrying a little pyrrhotite and pyrite. It averages 75% SiO_2 , 11% Fe, 1.2% S, and contains \$9 gold and 0.5 oz. silver per ton. The gold occurs evenly distributed and finely divided, so that cyanidation is necessary to recovery.

Fig. 98 is a plan of the mill and indicates the operation. The ore from the mine is dumped into a flat-bottom bin, the idea being to permit the ore to form its own slope, thus avoiding wear upon the bottom of the bin. It is coarsely crushed by a large 24 by 13 in. Blake crusher to 1.5-in. size, and is elevated by a belt elevator to the battery bin, a sample amounting to 2% of the ore being taken at the elevator head. The ore from the battery storage-bins is fed by automatic feeders as shown in Fig. 45, to the 40-stamp mill

of 910-lb. stamps, where it is wet-crushed in cyanide solution through a 26-mesh screen at the rate of 3 tons daily per head or 120 tons in all. The battery solution is kept at a strength of 0.06%

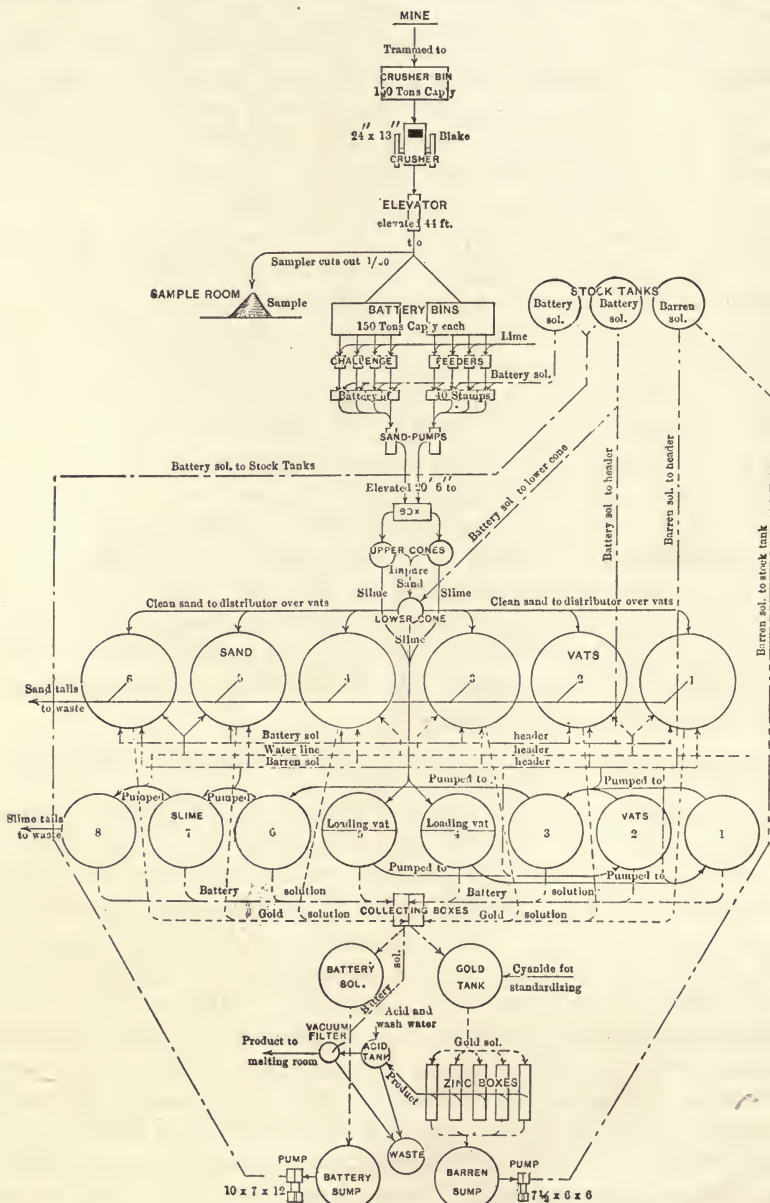

Fig. 98. PLAN OF OPERATION AT THE MATLAND MILL.

cyanide, and has 0.05% protective alkalinity. Four to five tons of solution are used per ton of ore. In crushing, 4 to 6 lb. quick-lime is added in the battery to assist later in the precipitation of the slime.

The proper separation of sand from slime is important. It is performed in the following way: The battery-discharge is elevated by Frenier sand-pumps to the distributor-box of the cone system as shown in Fig. 99. The feed in this box is divided evenly between

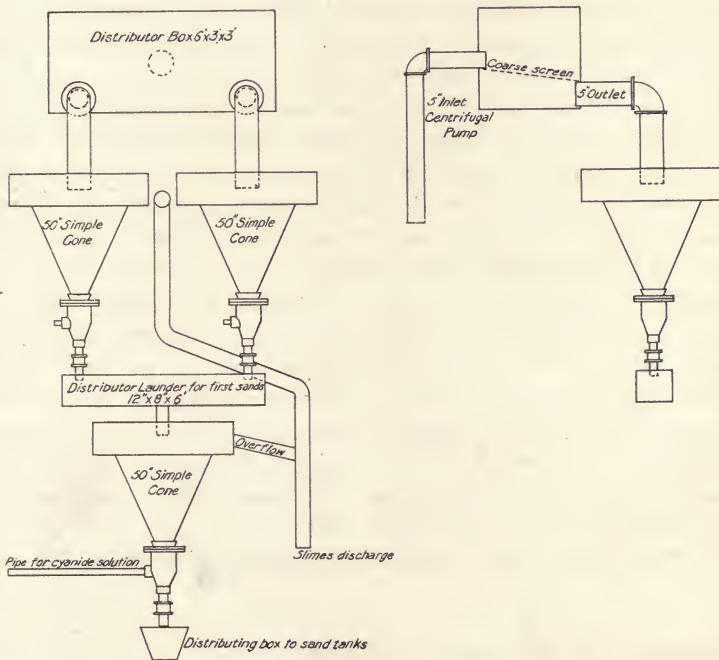

Fig. 99. SINGLE-CONE CLASSIFIERS.

two simple settling cones 50 in. diam. using no hydraulic water, so that as the sand settles and discharges at the bottom of the cones, it still carries slime. This spigot discharge is received in a launder which delivers it to a 50-in. hydraulic cone-classifier having a hydraulic supply, not of water but of battery solution. Thus a clean sand is separated at the spigot discharge that contains no more than 1 to 5% slime, while the slime with much of the solution joins the overflow from the first cones.

Treatment of the sand.—The clean sand from the spigot discharge of the lower cone, amounting to half the total weight of

ore, and containing $2\frac{1}{2}$ to 3 parts solution to one of sand, flows by launder to the Butters distributor and fills the tanks evenly.

The six 'sand-vats,' holding 140 tons each are 30 ft. diam. by 6 ft. deep, with lattice bottoms as shown in Fig. 68. The lattice is covered with cocoa-matting and the matting with 8-oz. duck. The filter lasts 10 months. A tank is filled in 60 hours. A system of dry filling is used, the vat not being filled first with water. All solution coming in with the sand is allowed to drain through the filter-bottom. This gives a more porous and easily leached product, since the slime is evenly distributed through the sand as it could not be in a vat first filled with solution. The average weight of a cubic foot of the sand is 93 pounds.

The vat, having been filled, is leveled with a stream of solution from a hose under low head. Battery solution is then run on for a period of 10 days. A small amount of slime in the solution forms a slight coating on the sand, and to insure satisfactory leaching, this occasionally is lightly raked to keep it pulverous. The battery-solution is followed by barren solution for six days more. This is allowed to drain and is followed by a water-wash, amounting to 10% by weight of the sand. To treat a charge of 140 tons of sand requires 900 tons of battery solution (exclusive of that which has passed through the filter filling) and 450 tons of barren solution. This large quantity of solution (ten parts of water to one of sand) and prolonged treatment (16 days) is by no means excessive, since experience shows that much weak solution must be constantly percolating through the charge.

The exhausted sand is sluiced through a launder of 8% grade with 100 to 150 tons of water. The tank is then ready for another charge.

Treatment of the slime.—Referring to Fig. 98, we note that the overflow from the upper and lower cones is united into a single flow, which goes by launder to one of the slime vats, No. 4 or 5, called 'loading-vats.' Each loading-vat has a central partition extending to 30 in. from the bottom. When the vat is filled the stream of slime-pulp continues to enter the vat quietly on one side, the solid portion settling out, while the nearly clear solution escapes over the rim of the tank at the opposite side. The vats are 24 ft. diam. by 12 ft. deep and hold 150 tons, and receive during 12 hours 300 tons of slime-pulp containing 12 tons of solution to one of slime. Thus 150 tons of slime is decanted and 30 tons is retained in the vat. It is allowed to settle and is decanted as closely as possible, then pumped by a centrifugal pump to slime

vat No. 1, barren solution being also added. Meanwhile the other loading-vat is filled, settled, and transferred to slime vat No. 2 with barren solution. Both vats, No. 1 and 2, are now decanted and the contents combined and transferred to vat No. 3, making a full charge of 60 tons of slime. Two more transfers, with barren solution added each time, are made to slime-vats No. 6 and 7, and finally a transfer to slime-vat No. 8 where the charge receives a final water-wash. After each transfer and dilution, several hours of agitation are given by pumping from the bottom of the vat and discharging into the top. After decanting the wash-water, the slime contains 55 to 60% moisture. The layer of thin slime is drawn back on the next charge, leaving a dry slime with but 47% moisture. This is sluiced out and run to waste.

Course of the solutions.—The rich gold-bearing solutions from the sand-vats, the only ones that run through zinc-boxes, are received in a collecting-box and pass to the gold tank where they are united and brought to standard strength by the addition of fresh KCN. This promotes precipitation at the zinc-boxes. The poor solutions from the sand-vats, and the decanted and overflow solutions from the slime, still called battery solutions, flow to another collecting box and thence to the battery sump. The solution in the sump is pumped back to the two battery-solution stock-tanks for use again. It is not yet sufficiently rich in gold to justify passing it through the zinc-boxes.

It is thus seen that the cyanide solution makes a closed circuit, the only part escaping being that in the exhausted sand and slime. The consumption of potassium cyanide is but 0.84 lb. per ton of ore treated.

Precipitation.—From the gold-tank the solution passes in a regulated flow to the five zinc-boxes each of 224 cu. ft. capacity, having eight compartments. Here the gold is precipitated. The barren solution passing on, enters the barren-solution sump whence it is pumped back to the barren-solution stock-tank at the highest part of the mill. Of this solution, amounting to some 400 tons daily, 25% is used for the treatment of sand and the remainder for the slime. The consumption of zinc averages 1.33 lb. per ton of ore treated.

Cleaning up.—A clean-up, varying somewhat in detail from that described under the 'first method,' is made twice monthly. To clean up a box, the flow from the gold-solution tank is shut off and water run in 15 minutes to displace the solution in the shaving. The zinc in the first compartment is shaken up and down to remove

adhering precipitate and set aside. The water is bailed close to the precipitate in the compartment into the next compartment. The plug at the bottom of the compartment is then withdrawn and the remaining water, with some precipitate, flows through a launder to the acid-tank. The screen-bottom is taken out, and the remaining precipitate is removed, placed in a tub, and carried to the acid-tank. The compartment is washed with a hose, the water going to the acid-tank. The plug and screen is replaced, and the zinc shaving put back, with shaving from the second compartment, to completely fill the first. The compartments are cleaned in succession, the zinc-shaving being moved toward the head until all compartments are filled. In filling the first compartment a slight flow of solution is started to avoid undue exposure to the air, and the water from the last compartment is poured into an adjoining zinc-box. The acid-tank thus receives all the precipitate and some of the wash-water. One man cleans up the five boxes in 12 hours.

The precipitate is allowed to settle in the acid-tank, then the clear supernatant solution is closely syphoned into a waste tank that holds 25 tons of water, and shown in Fig. 98. Concentrated sulphuric acid is next added to the acid tank and the mixture is stirred in by hand to avoid boiling over. The treatment lasts an hour. To avoid fume a well ventilated portion of the precipitating room is chosen for the acid-tank. Acid treatment being now complete, the tank is partly filled with water, the vacuum filter started, and the entire content of the acid-tank filtered without further washing. The filtrate goes to the waste tank.

The precipitate is blown from the filter-frame, collected in the hopper-shaped bottom of the filter vat, withdrawn in pans, and taken to the melting-room and dried in a muffle furnace. To 10 parts of the dry precipitate are added and mixed 4 parts soda, 1 part borax, 1.5 parts sand and 0.2 parts fluorspar. The mixture is melted quickly in a No. 200 graphite crucible, in a wind-furnace having a forced or under-grate blast. The content of the crucible with the slag is poured into molds and the slag removed upon cooling.

This slag contains matte, carrying as much as \$10 gold per pound. It is accordingly remelted with sand, flux, and 10% by weight of scrap-iron. The fusion gives a coppery bullion 700 fine in silver and 80 fine in gold, and a slag that is shipped to a smelting works. The ingot, weighing 200 ounces, is treated with hot concentrated nitric acid in a porcelain-lined kettle and gives a residue containing 50% Au and 25% Ag. This residue is added to the zinc-box precipitate of the next clean-up, while the acid solution,

containing most of the silver, is treated with soda which precipitates the silver carbonate. This is roasted at a low red heat, and yields silver which is easily fluxed and melted in a crucible and cast in the form of a bar.

The united solutions from the acid tank and the suction filter are retained in the waste sump. They contain \$2 gold per ton. The solution is treated with fine zinc to precipitate the gold; sulphuric acid is added and the mixture well stirred to remove the excess of zinc. Some 90% of the gold is thus precipitated. The sweepings around the zinc-boxes are thrown into the sump and their content recovered once in six months.

The extraction at the Maitland mill in 1904 amounted to 75.5% of the gold and 44.3% of the silver. The total cost, including general expense, but not depreciation of the plant was \$1.61 per ton of ore treated.

46. CYANIDATION OF CRIPPLE CREEK ORE (FIFTH METHOD).

The ores of the Cripple Creek district, Colorado, are phonolites and are of two kinds: first, the weathered surface ore, having little or no tellurium and containing free, finely disseminated gold; and second, the deeper-lying ores containing gold combined with tellurium as sylvanite and calaverite, with some nearly barren pyrite. The surface ores are treated raw. The telluride ores receive an oxidizing roast before cyanide treatment. The treatment of the telluride ores we are now to consider.

Metallic Extraction Co., Cyanide, Colorado.—The ore, coarsely crushed to $\frac{3}{4}$ -in. size, is stored in bins, then supplied to a revolving dryer, and after drying crushed to 30-mesh size, as described in connection with Fig. 25. The product is elevated to storage hoppers from which a regulated feed is delivered to the roasting-furnaces. The roasting not only breaks the combination of gold and tellurium, but makes the ore porous, and accessible to the solution, and causes it to be more readily leached. The roasting is done in one of the mechanical roasters of the Argall or the Ropp straight-line type. The cooling apparatus, which receives the hot ore from the roasting furnace, is a flat-bottomed trough, water-cooled by pipes beneath. The ore (first mixed with 10 lb. quicklime per ton) is moved along by scrapers which deliver it to a storage pit at the end of the trough. At the discharge end, the ore is sprinkled, before leaving the trough, with the cyanide solution. This cools it, prevents dusting, and starts dissolution.

The drying and roasting-furnaces, as well as the housing of the dry crushing machines, are connected by flues to two fan blowers, each capable of delivering 10,000 cu. ft. air per minute. These fans deliver the dust to a bag-house, described under the 'Bartlett Process.' Dust, thus recovered, is about twice the value of the ore from which it arises. It is briquetted in a White briquetting-press, Fig. 164, and smelted.

The leaching tanks are 50 ft. diam. by 6 ft. deep, constructed as shown in Fig. 70 and 71, each holding 400 tons of ore. In operation, the tank is filled with ore from two-wheeled buggies, and 0.7% KCN solution is admitted below under pressure, so that the ore and solution rising at the same rate fill the tank in 50 hours. The solution stands on the ore 24 hours, then more is added and drawn off. (This practice is inferior to that of actually percolating the ore.) The operation, repeated several times, reduces the gold content to one third of the original in five days.

A weak solution of 0.25% KCN is used in the same way for three days. The charge is then given several water washes, drained, and finally washed out with water under high pressure from a hose into a launder, the washing and discharging taking two days more. At Cyanide, where the plant is situated on a level site, the tailing is elevated by a centrifugal pump to a launder on a high trestle, discharged to a dump, and impounded behind a low dam. In the launder is a series of transverse riffles behind which any coarse particles of gold, produced by roasting, are caught. These particles are likely to be found in roasted telluride ore, in consequence of the condition of the gold when first released from combination with tellurium that causes it to form drops, shot, or other coarse particles. As an alternative to washing out the tailing, it may be shoveled through side-discharge doors, Fig. 72, and trammed away, a more expensive method.

The cycle of treatment as above detailed was 12½ days.

The value of the original ore, charged to the vat, may be assumed to be 0.90 oz. Au and 0.5 oz. Ag per ton, while the tailing retains 0.06 oz. Au and 0.2 oz. Ag per ton. The extraction accordingly is 93.33% for the gold and 60% for the silver while the loss in cyanide is 1.75 lb. per ton of ore treated. The assay of the tailing shows as good extraction from the grains of 40-mesh size as from those passing a 200-mesh screen, and indicates how effective roasting is in preparation for subsequent leaching.

Each kind of solution passes to a separate gold-solution tank and is run in regulated flow through separate zinc boxes to its own

sump to be strengthened for re-use. The zinc consumed amounts to 0.9 lb. per ton of ore treated. The precipitation and the details of subsequent operation are described under the 'first method.' The cost of treatment of Cripple Creek ore is \$2 to \$2.50 per ton including roasting, when performed on the large scale indicated.

The Golden Cycle Mill, Colorado City, Colorado.—The ore from Cripple Creek, treated at the mill, is coarsely crushed to 2-in. size

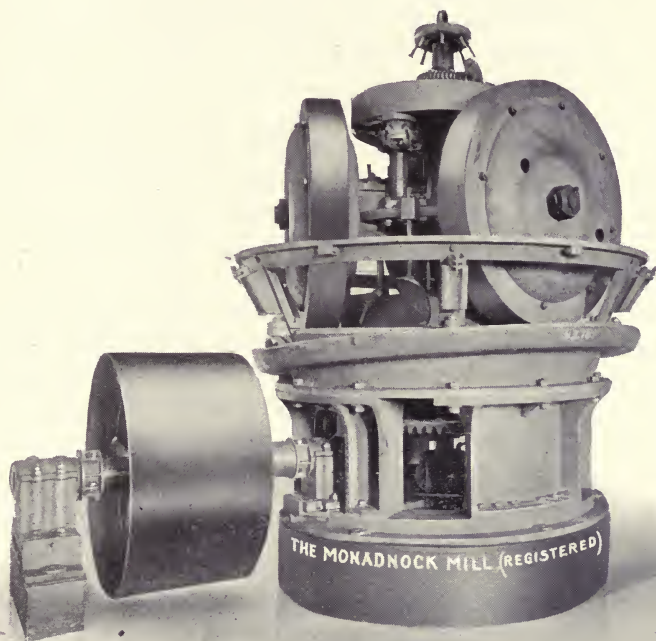

Fig. 100. MONADNOCK (CHILEAN) MILL.

in rock-breakers and passed through coarse-crushing rolls which reduce it to one inch after which a sample is removed automatically. The ore is taken by a belt-conveyor to storage bins holding 8000 tons. This collects the ore into large lots and insures greater uniformity of treatment. The ore is removed from the storage bins on a troughed belt-conveyor and is delivered to intermediate rolls able to crush without preliminary drying* to $\frac{1}{4}$ -in. size. This rather coarse ore is delivered to Edwards roasters, see Fig. 38 and 39. It has been found that roasting can be thoroughly done with

ore no finer than this. The telluride of gold, where segregated in pieces, forms particles of gold in roasting that are too large to be dissolved in the potassium cyanide. The roasted ore, after cooling, is ground to 60 mesh in cyanide solution in Chilean mills, see Fig. 100. The bed of the mill carries a shallow pool of mercury, and large particles of gold are amalgamated and retained here. It has been found, that the extraction is quite as good when the ore is ground to this mesh as when ground to 200 mesh. The mill in the illustration is shown with the surrounding screens removed to expose the rollers. The rollers travel upon a ring-die, the crushing being done between the die and the roller. The ore is fed into the hopper near the top and enters through pipes in front of the rollers. A scraper in front of each roller deflects the pulp in front, but is so set as to escape the mercury pool inside the ring-die. The ore, when ground sufficiently fine, splashes out through the screens, and is conducted by the circular cast-iron launder that surrounds the mill to the point of discharge.

The resulting pulp is elevated to classifiers, and separated as usual into sand and slime, the sand being conducted directly to the leaching tank, while the separated slime, after four hours agitation in a tall conical-bottom tank, is drawn to Argall vacuum filter-presses of the Moore type.

47. ACTION OF COPPER IN CYANIDING.

Copper in ore is generally understood to be a serious detriment to successful cyanidation, since it passes into solution and consumes cyanide. The difficulty can be overcome, where little copper is present, by running strong cyanide solution into the stream of gold-solution as it enters the zinc-box. This strengthens the entering solution and prevents the precipitation of copper. The copper that enters the solution consumes potassium cyanide.

The Hunt ammonium cyanide process.—This is a simple process dependent on the fact that ammonium chloride added to potassium cyanide solution has a protective influence upon the cyanide and a solvent action upon copper.

At Dale, San Bernardino county, California, occurs a copper-bearing gold ore containing the copper in the form of silicate. The silicate of copper, being soluble in cyanide, causes a loss of 7 to 8 lb. cyanide per ton of ore by the ordinary treatment. By Hunt's method 8 lb. quick-lime is added per ton of ore. The ore in the vat is then leached with a 0.15% solution of cyanide to which has been added 6 lb. ammonium chloride per ton of solution. The solution after

contact with the ore is drained, and the ore given six days' continuous contact and washing. The gold-bearing solution can be precipitated in zinc-boxes, but electrolytic precipitation is preferred. In the precipitation, lead anodes and aluminum cathodes are desired. The anodes are peroxidized by dipping into a solution of potassium permanganate before use. A current density of 3 amperes per square foot is employed. The gold, silver, and copper do not precipitate as an adhering coating upon the aluminum cathodes, but fall from them as sludge to the bottom of the tank.

The method has been successfully applied to the treatment of copper-bearing mill-tailing dumps exposed for years to the weather. Potassium or sodium cyanide costs 18 to 20c. per pound. Ammonium chloride, commercially called muriate of ammonia, costs as an estimate 5 to 6c. per pound.

48. CYANIDATION OF CONCENTRATE.

Two cases arise in respect to the treatment of the sulphide concentrate obtained from gold or silver ores. In the first, the valuable metals enter the concentrate, while the gangue is comparatively barren. In this case only a small percentage of the total ore need be cyanided. In the second, all parts of the ore have value. Here we have the choice between finely grinding all the ore for extraction or on the other hand treating a large part of the ore by ordinary methods of extraction, but giving the concentrate, which is of higher grade, and in smaller quantity, a more careful treatment. The removal of the concentrate from the ore frees the tailing from acid sulphates and base metals which would interfere with cyanidation.

Gold and silver-bearing concentrate can be cyanided with a high extraction in some cases. The gold must be fine and the silver present as silver chloride or sulphide. When silver is the principal metal to be extracted, the treatment must be prolonged. Thus with ore re-ground to 100-mesh size, an extraction of 93.5% of the silver and 96% of the gold was obtained in one instance on ore of 130 oz. Ag and 1 oz. Au per ton. This was accomplished by an eight-day treatment by agitation and decantation, which is equivalent to leaching 30 days. For high-grade impure concentrate the best method is to give a chloridizing roast, following with a careful and prolonged leaching with cyanide solution. The silver compounds are thus converted into a readily-soluble form, and the ore is rendered porous and penetrable by the solution.

Treatment at the Standard plant, Bodie, California.—The

concentrate, consisting of iron oxide with a little pyrite is charged in one-ton lots into an ordinary 5-ft. pan (see Fig. 103), lime and water first having been added to dilute the pulp to 45% solid matter. The charge is ground 48 hours, then cyanide is added in quantity sufficient to strengthen the solution to 1.2%. Grinding is continued 24 hours with additions at intervals of quick-lime and cyanide. The lime insures alkalinity, the cyanide maintains the strength of the solution at a fixed percentage. During the grinding an oxidizing action occurs and the pulp changes in color from a greenish shade to a brownish red. It is drawn into a settler, maintained in motion for 24 hours, and is diluted with weak cyanide solution, filling the settler. The whole content is then run to the filter press. The filtrate from the press, containing the gold in solution, is precipitated with zinc-shaving.

The extraction of metals, 96.8% of the gold and 84.1% of the silver, is high. The cost also, \$7.91 per ton, is high, and 18 to 20 lb. cyanide is consumed per ton of concentrate treated.

Treatment at Harrisburg, Arizona.—Seventy tons of ore daily were concentrated, yielding two tons of concentrate, while the mill-tailing being of little value was thrown away. The raw concentrate is exposed to the air for a while to partly oxidize it, since it is found that when thus treated it grinds more easily, and the extraction is better. It is then charged to a 5-ft. pan, the charge consisting of 1.5 tons of concentrate and 1 ton of solution containing 6 lb. quick-lime and 6 lb. potassium cyanide. The grinding, which takes 8 hp., was continued 8 hours after adding 2 lb. more cyanide, the temperature is increased some 40°. The content of the pan, not too finely ground, is now run into a 15-ton leaching tank. When the slime is partly settled in the vat, dry tailing is sprinkled in. This coarse material facilitates percolation, and we thus have a number of layers of charge interstratified with middling. The tank having been filled, the charge is continuously leached with cyanide solution while the other tank is being filled. Thus each tank is 7 days filling, followed by 4 days leaching, and 3 days washing, before it is discharged. The average extraction is 94%, and the consumption of cyanide is 8 lb. per ton. The cost of treatment of the concentrate is estimated \$5 per ton.

49. THE BROMO-CYANOGEN PROCESS.

This method, called also the 'Diehl process,' is practised upon the sulpho-telluride ores of Western Australia. A typical ore contains 50% SiO₂; 10% Fe; 7 to 22% CaO and MgO, 3 to 7% S;

0.03 to 0.10% Te, and 2 to 3 oz. gold per ton. The ore contains iron, calcium, and magnesium carbonates which give it cement-like properties after roasting, disposing it to cake or set when subjected to the action of cyanide solution in the tank. Since the Diehl process is applied to the raw ore, this trouble is avoided, and the process has become a successful method of treating a certain kind of ore.

Fine grinding and amalgamation was tried upon the ore, but an extraction of only 20% resulted. Upon roasting and amalgamating in pans, the extraction was 44%. Concentration gave poor results owing to the loss of the finely ground almost inpalpable tellurides escaping with the tailings. Ordinary cyanidation gave extractions of 60 to 77%, but with preliminary roasting, it yielded a total of 93 to 94 per cent.

It is found that the ore must be finely ground, or slimed as it may be termed, to obtain a good extraction. At the same time we must distinguish between a product that contains many fine hard particles of quartz and one consisting of real slime composed of colloid substances, in which no grit exists. Moreover, the above tests show that only a part of the gold of the ore is in a metallic state, the rest being present as telluride and locked within the crystals of pyrite. Owing to the brittleness of the telluride, the finer the slime the richer is the content of gold.

The process.—The ore is coarsely crushed and fed to the stamps. The pulp from the stamps is classified, the overflow going to the agitation vats, while the underflow, of coarse sand, goes to the tube-mills for re-grinding. In the tube-mills the sand is crushed so that most of it passes a 200-mesh screen. The product, still containing 5% sandy particles, is again classified, the overflow as before going to the agitation vats, while the sand is returned to the tube-mill for re-crushing. Thus the agitation vats recover only a slimed product, fine enough to pass a 200-mesh screen. The agitation vat (See Fig. 101) is 25 ft. diam. by 8 ft. high. When it has been filled, potassium cyanide is added to produce a 0.22% KCN solution. This is used in the proportion of two of solution to one of the dry slime, and the whole is stirred for a period varying between 16 and 24 hours. This is followed by the addition of bromo-cyanogen to increase the strength of the solution by 0.055% salt used per ton of dry slime. Agitation is continued until the gold is in solution, after which the whole is filter-pressed. Since, by this method of final treatment, but little water is required, the

process has an important advantage in the country mentioned where water is worth 50c. per 1000 gallons.

The pulp is pumped to presses of the Dehne type that have a capacity of three to five tons of dry slime per charge, the thickness of the cake in the recesses varying from one to three inches. The distance-frames in which the cakes form are 40 in. square, there being 30 to 50 cakes in a press. Of the solution 70% is recovered at once; then a weak solution or water is forced through, and complete washing accomplished by the use of a half ton of solution per ton of slime. Compressed air, under 90 lb. pressure is next

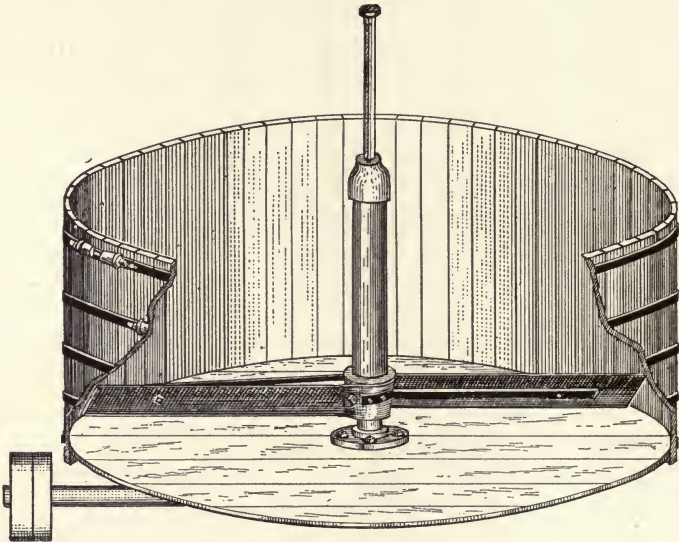
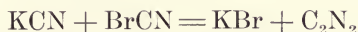

Fig. 101. AGITATING VAT.

introduced. This soon expels the water from the cakes leaving only 11 to 15% moisture. The press being opened, the cakes are discharged into cars below and trammed to the dump. It takes two men 30 to 45 minutes to discharge a press, clean the frames, and close it, ready for another charge. The time of filling, using a pressure of 60 to 100 lb. per sq. in., is 20 to 30 minutes. Wash-water is used 15 to 25 minutes, and compressed air for 10 minutes. The full cycle of operations can be completed therefore in two hours. Two men, using two presses, handle seven charges per 8-hour shift, or 40 tons dry slime per press in 24 hours. The extraction by the use of the press is 90 per cent.

Bromo-cyanide is made by dissolving the commercial crystals in water, or, when produced at the works, by adding bromine-water

to cyanide solution. The cyanide reacts with potassium bromide as follows:



Cyanogen (C_2N_2) in nascent condition acts energetically on the gold as follows:



Bromo-cyanide does not require the prior aeration necessary in the use of the ordinary solution. It is expensive, however, and has been applied only to sulpho-tellurides that are unattacked, or are attacked but slowly by plain cyanide.

50. SMELTING OF GOLD ORES.

Gold may be recovered from its ore by the processes of silver-lead, or of copper-matte smelting. It often is found in copper or lead-bearing ores and when in excess of 0.05 oz. per ton, is paid for by the smelting works at the rate of \$19 to \$19.50 per ounce. Practically all the gold is recovered in smelting, and this would be the best method of treatment were it not for the high cost of freight and of treatment. If smelted near the mine in a works operated by the mining company, the cost of freight is eliminated. The charge for dry, fairly silicious ores, from Cripple Creek and from Boulder county, Colorado, is from \$4 to \$10 per ton, according to grade. The low-grade ores are subject to a low treatment rate. On the other hand ore treated by milling and amalgamation, or by cyanidation, while the extraction is less, often yields higher net returns. An example is found in the case of the dry silicious gold ore from Boulder county, Colorado, containing 0.5 oz. Ag per ton, giving 70% extraction by milling and amalgamation, or of 90% by cyanidation. In comparing the costs we have:

SMELTING.		
100% of 0.5 oz. Au at.....	\$19.00	\$9.50
Mining	2.00	
Freight	1.50	
Treatment	4.00	7.50
		7.50
	Net returns	\$2.00
MILLING AND AMALGAMATION.		
70% of 0.5 oz. Au at.....	\$20.50	\$7.17
Mining	2.00	
Milling	1.00	3.00
		3.00
	Net returns	\$4.17

CYANIDATION.

90% of 0.5 oz. Au at.....	\$20.50	\$9.23
Mining	2.00	
Cyaniding	1.65	3.65
		<hr/>
	Net returns	\$5.58

From the above comparison it is seen that cyaniding is the most profitable method of treatment for this grade of ore, and at this place.

PART IV. SILVER

PART IV. SILVER.

51. SILVER ORE.

The silver minerals of importance in treatment are as follows:

Native silver sometimes occurs in the form of flakes or leaves, and as wire-silver and metallic silver adherent to native copper. Native silver can be readily amalgamated, but when present in particles of visible size it is so slowly soluble in cyanide, that practically no extraction can be obtained.

Cerargyrite (horn-silver, silver chloride), AgCl , is widely distributed. At mines it is found in the upper oxidized zones. It is probable that much of the so-called chloride ore is really a chloro-bromide (embolite). The ore is readily amalgamated and is free-milling. The silver also is readily soluble in cyanide and in sodium hyposulphite solutions.

Argentite, Ag_2S , is one of the common silver ores. By using chemicals (bluestone and salt) it can be amalgamated in pans, and the silver extracted thus from the ore. It is soluble in potassium cyanide solution.

Stephanite, $5\text{Ag}_2\text{S}, \text{Sb}_2\text{S}_3$; pyrargyrite, $3\text{Ag}_2\text{S}, \text{Sb}_2\text{S}_3$; proustite, $3\text{Ag}_2\text{S}, \text{As}_2\text{S}_3$; dycroasite, Ag_3Sb are silver sulph-arsenides or sulph-antimonides, refractory in amalgamation, even with chemicals, sparingly soluble in cyanide solution, but readily soluble in a solution of mercurous potassic cyanide.

Finally we have those silver sulphides that contain also copper. These are polybasite, $9(\text{Ag}_2\text{Cu})\text{S}(\text{SbAs})_2\text{S}_3$, and tetrahedrite (gray copper ore, fahlerz), $4\text{CuFeAg}_2(\text{HgZn})\text{S}, (\text{SbAs})\text{S}_3$ the most complex of all, in which the silver varies from 0.06 to 31%, being higher in the arsenical and lower in the antimonial varieties. These sulphides are refractory to any amalgamation method, and because of their copper content are precluded from treatment by cyanide, even when roasted. This does not interfere with treatment by hyposulphite lixiviation after roasting.

A number of rare minerals containing silver could also be enumerated, but for the metallurgist the minerals above named are the important ones.

Silver ores in general contain but a small percentage of precious metal. They are composed mostly of gangue (waste matter of the ore), and many are treated that contain less than 0.1 to 0.2% silver. Thus we have at the Comstock Lode, Nevada, silver in native form and as sulphide, but oxides of iron and manganese with the associated sulphides, pyrite, blende, galena, and chalcopyrite. At the Ontario mine, Park City, Utah, the silver occurs as argentite and tetrahedrite in a gangue of quartz and clay associated with a little of the heavy minerals blende and galena. These sulphides carry silver which is recovered with the concentrate in case of concentration.

52. THE EXTRACTION OF SILVER FROM ORES.

Silver is extracted from its ores by amalgamation in pans, by hydro-metallurgical methods, and by smelting. Amalgamation is now used less in America than formerly, smelting having taken the place, not only because of better extraction and lower treatment rates, but because ores are more easily shipped to smelting works in result of the extension of railroad facilities. Certain ores contain the silver in a form suitable for cyaniding, and the hydro-metallurgical method in consequence is coming forward. The other methods have partly dropped out of use. No reason appears why hyposulphite lixiviation should not revive under the stimulus of the recent methods of agitation and filter-pressing. The patio process, formerly much practised in Mexico where conditions favored, has been superseded by cyaniding in many cases, on account of the lower cost of operating the latter process, but in the past, large quantities of silver have been extracted by the patio process.

53. SILVER MILLING AND AMALGAMATION.

The silver ores suitable to treat by milling and amalgamation are those that contain the metal in such form as to be acted upon by mercury when assisted by agitation, heat, and certain chemicals. The ore is first crushed fine by stamps, as in gold milling, then treated for several hours in pans, the reactions being slow compared with those of the amalgamation of gold. In gold milling, the greater part of the gold can be arrested on an apron-plate during the few seconds in which the ore is passing; while in silver milling, the ore-pulp has several hours contact with mercury aided by heat and chemicals, and is but slowly amalgamated. In gold milling, ore containing 0.5 oz. Au per ton can be profitably milled. In

silver milling, ore of equivalent value would contain 20 oz. Ag per ton, or 40 times as much metal. Thus is seen why so much time is allowed in silver milling, and why so many precautions must be taken to be sure that all metal possible is recovered. Several ounces of silver per ton often remain in the tailing.

The silver metals suited to pan amalgamation are cerargyrite (horn silver, silver chloride), native silver in flakes, wire, or other forms, and certain silver sulphides, notably argentite (Ag_2S). When the ore is refractory, containing arsenical and antimonial sulphides, and especially containing tetrahedrite, galena, or blende, it is necessary to roast with salt, setting free the silver or converting it into the form of a chloride, which becomes susceptible to amalgamation. There is no sharp line of demarkation between free-milling and roasting milling ores. Often the upper part of a vein is free-milling. In depth base metals and sulphides begin to come in, and it finally becomes necessary to roast the ore. The best extraction therefore is obtained from decomposed or oxidized ore, in which the silver minerals occur in a form that renders possible the action of the mercury. There are few deposits of oxidized ores containing silver chloride and native silver that as a whole are suitable for free silver milling. Such ore, so far as silver chloride is concerned, can also be treated by cyanidation, but the latter method would not recover native silver.

Arsenic and antimony compounds interfere with amalgamation by fouling the quicksilver, checking the reactions of the chemicals added to promote amalgamation, and by carrying off silver, which is incapable of being amalgamated with them.

We may divide the methods of silver-milling into

- (1) Wet silver-milling, or the Washoe process, which includes (a), the tank mill, and (b) the Boss process.
- (2) Combination process, combining the gold-mill and the silver-mill.
- (3) Dry silver-milling, or the Reese River process.

54. WET SILVER-MILLING WITH TANK SETTLING.

This is also known as the Washoe process, receiving the name from the place where it was perfected for the treatment of ores from the Comstock Lode, Nevada. The process is applicable to the so-called free-milling ores, in which the silver occurs native, as chloride or in small amount as argentite. The ore should be free from lead and from any tough clayey gangue.

In wet silver-milling, when settling tanks are used, the process

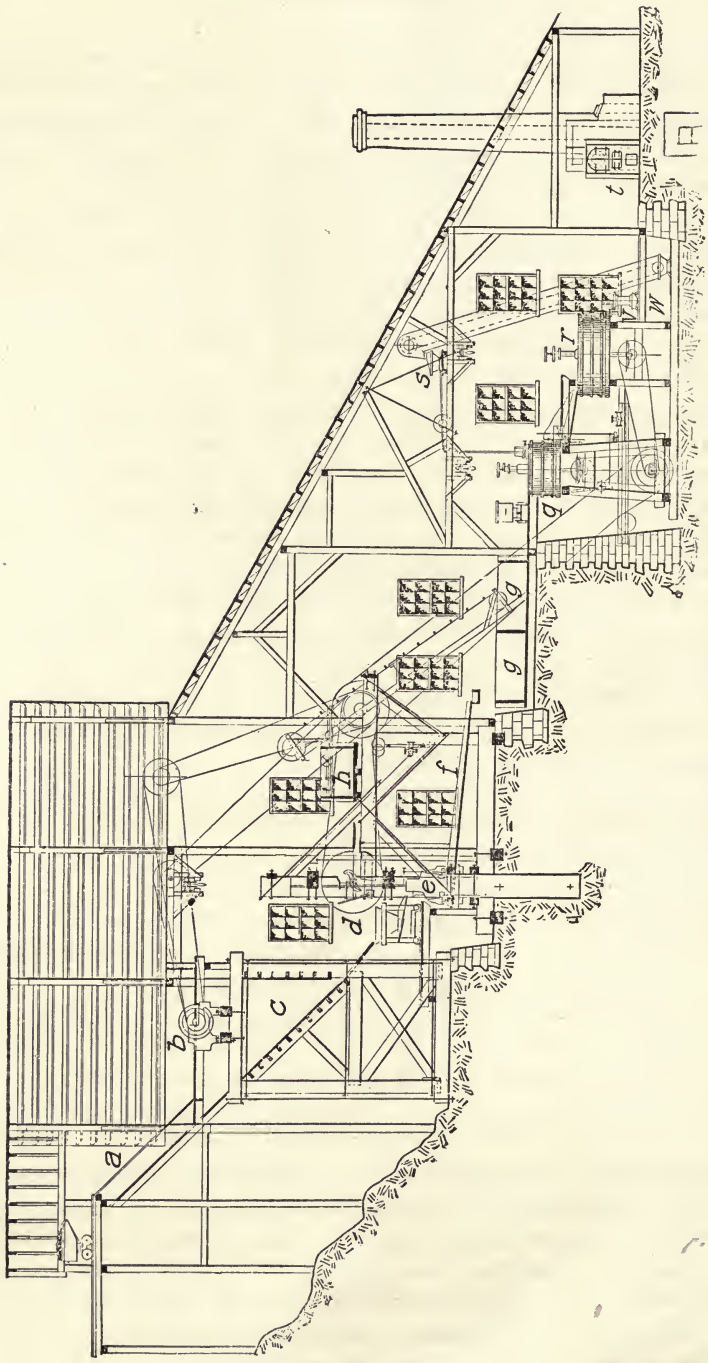

Fig. 102. WET SILVER MILL.

consists in coarse-crushing the ore, stamping it fine, and collecting it in settling tanks. The crushed sand is ground in amalgamating pans using mercury to collect the silver. The sand is separated from the silver-bearing mercury in settling pans and is rejected. The amalgam is strained from the mercury, retorted, and the retort-residue melted into silver ingots. Gold present in the ore is recovered as well as the silver. The process resembles gold milling except that amalgamation and the removal of the amalgam is effected in pans.

Fig. 102 is a sectional elevation of a wet-crushing tank-mill for the treatment of free-milling silver ores. The ore from the mine, as in gold milling, is dumped from the tram-car over a grizzly or bar-screen *a*, the bars being set $1\frac{1}{4}$ in. apart. The fine falls into the sloping bottom storage bin *c*, while the lump ore is received upon the feed-floor at the mouth of the Blake crusher *b*, and after being coarsely crushed, joins the fine in the bin. The coarse crushing is done during the 10-hour day-shift.

The ore passing to the battery is fed by an automatic feeder *d* such as is used in gold milling. The flow of ore to the automatic feeder is controlled by gates at the inclined outlet chutes and the feeder is kept full to supply the stamps *e* uniformly as required. Water (6 to 8 tons per ton of ore) is at the same time supplied in the mortar, and the suspended ore forms a pulp, which is splashed through the 30-mesh screens by the motion of the stamps. A double-discharge mortar of the type suited to silver milling is seen at Fig. 48. The large screen-opening possible with a double discharge favors a more rapid pulverization than would be possible with a single-discharge mortar. (For further particulars of gravity stamps see the detailed description under 'Gold Milling.')

The pulp flows by launders *f* into the settling boxes or tank *g* 7 ft. square by 3 ft. deep. There is a double row of these tanks, 20 in a row, occupying the length of the mill in front of the stamps. The flow of the pulp is from box to box until it goes by launder to a settling-pond outside the mill. Most of the solids settle in the first boxes, a further portion dropping in the succeeding ones, and the turbid water passing to the pond. Here it has its final chance to settle before running to waste, or it may be again used in the mill if water is so scarce that it pays to do this. The settled slime is dug from the pond at a later time and treated like the rest of the crushed ore.

A variation of this method, shown in Fig. 102, consists in conducting the flow from the last box *g'* by an inclined elevator to

a tank *h* situated in front of and above the battery, the dirty water being again used for stamping. When the first settling box is full the flow of pulp is by-passed into the next one. The contents of the full box is shoveled upon the floor adjoining, and thence taken as needed to the amalgamating-pans *g*. The emptied box has the flow of the last one turned into it, thus making it the last in the series, and the launders are so arranged that this can be done.

The ore, thrown out upon the floor, is fed directly into the pan,

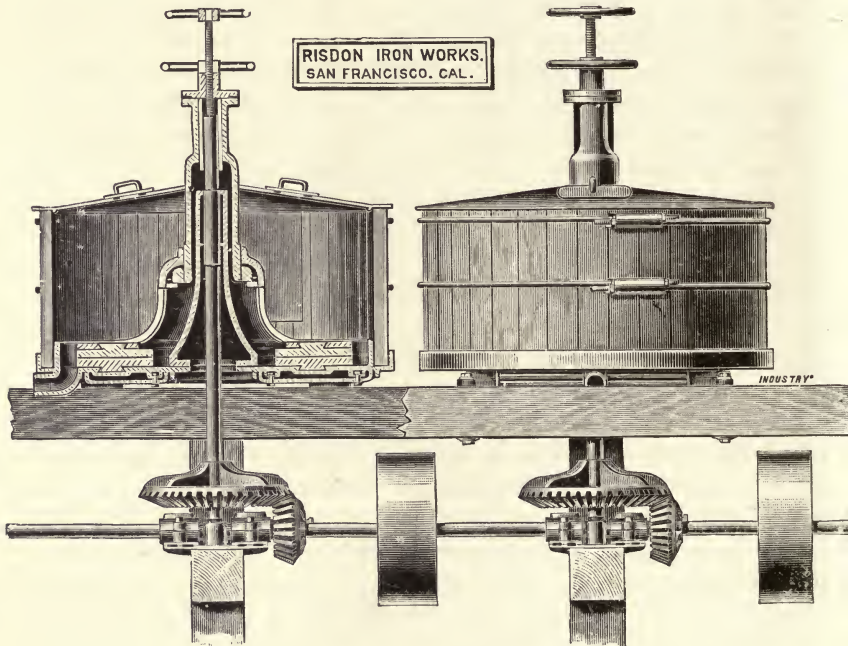

Fig. 103. COMBINATION AMALGAMATING PAN.

or loaded into the tram-car seen in Fig. 102, and conveyed to the pan.

Fig. 103 represents two of these pans. One is shown in section, the other in elevation. The pan shown in section is 5 ft. diam. by 30 in. deep, and has a cast-iron bottom and the sides made of wooden staves. It is furnished with a central sleeve or cone through which rises a shaft carrying a cylindrical casting called a spider, which becomes bell-shaped and broadens into feet below. The spider carries, bolted to the feet, a flat cast-iron ring called a muller, and to the underside of the muller is attached six shoes

or plates of chilled cast-iron $2\frac{1}{2}$ in. thick. The spider, muller, and shoes are raised or lowered as desired, by means of a hand-wheel and screw at the top of the shaft, which is driven by bevel gearing from the horizontal shaft and pulley below. Upon the bottom of the pan rest chilled cast-iron plates or dies that furnish the lower or fixed grinding surface. The shoes attached to the muller revolve 60 rev. per min., and rubbing upon the dies, grind the ore.

In working the pans, the shoes are raised $\frac{1}{2}$ in. from the dies and set in motion, the pan is partly filled with water, and 3000 lb. of the damp pulverized ore are shoveled in. The ore and water nearly fill the pan and the mixture is stirred until it is of the consistence of honey. The motion establishes a movement or current of pulp beneath the muller toward the periphery. At the periphery it rises, flows toward the center, sinks, and passes again under the shoes. To assist the action, the rising pulp is deflected inward by cast-iron wing-plates.

After thorough mixing in the pan the shoes are lowered until they touch the dies, and grinding goes on for $1\frac{1}{2}$ hours, the content of the pan being meanwhile heated nearly to boiling by steam under pressure from a pipe that dips beneath the surface of the charge, the pan being covered. Sometimes the pan is provided with a double bottom into which exhaust steam from the engine is introduced.

After grinding, the shoes are raised and 300 lb. mercury (10% the weight of the ore) is added, by sprinkling it through a fine strainer. The mixing is then continued four hours. The mercury takes up silver most rapidly at first, but the action afterward slackens. At the end of the first hour, in one instance, 74.7% was amalgamated, of the second hour 76.3%, of the third 77.7%, and at the end of the fourth, 81.0% the silver contained in the ore. After the fourth hour no further silver amalgamated. The globules of mercury suspended in the pulp take the silver as they come in contact with it. Care is taken to have the pulp of the right consistence so that mercury will not settle out. This condition is shown when a wooden stick, dipped in the pulp and withdrawn, is found to be covered with a thick mud in which are disseminated minute globules of mercury. If the ore is refractory, salt and copper-sulphate^{45c} are advantageously added at the beginning of grinding to accelerate the reactions, promote amalgamation, and increase the yield of silver.

The time required for grinding varies from four to six hours. In mills treating chloride ore, the charges are finished in four hours without grinding. In treating refractory ores, the total

time for a charge becomes six to eight hours, of which time four hours are required for grinding.

The charge above treated having been amalgamated, the pan is ready to empty into the settler *r*. About 15 minutes before the discharging, the speed of the muller is reduced to 40 rev. per min. and the pan filled to the top with water. A plug closing the discharge opening at the bottom of the pan, seen at the left in section, Fig. 103, is pulled out, and the entire content run by launder to an 8-ft. settler, at a lower level, shown at the right of the amalgamating pans in Fig. 102. Emptying the pan and washing it with a hose takes half an hour, after which time the plug is replaced, and the pan is ready for another charge. Thus the total time for the cycle of operations described is six hours, making it possible to treat four charges daily.

The reactions that take place in the pan are as follows:

Native silver in threads, films, flakes, or grains readily combines with the mercury and forms an amalgam which contains a large excess of mercury.

Silver chloride in contact with the mercury decomposes as follows:

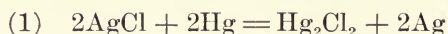

The metallic silver liberated amalgamates with additional mercury. The particles of iron, abraded from the stamps and the bottom of the pan, decompose the mercury salt and liberate the mercury as follows:

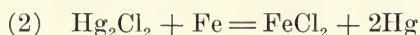

In many so-called free-milling silver ores argentite is contained which in part is decomposed by mercury as follows:



The sulphide of mercury thus formed is lost. We have already stated that chemicals, notably copper sulphate and common salt, are added to promote the decomposition of the silver sulphide. There is added in the amalgamating pan from 6 to 18 lb. salt and from 3 to 9 lb. copper sulphate per ton of ore treated. The reactions as generally given are the following:

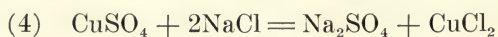

The chloride of copper acting on the silver sulphide decomposes it:

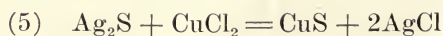

The silver chloride amalgamates as shown by reaction (1).

The complete separation of the mercury with the silver-amalgam is effected in the settler, there being one settler provided for two amalgamating pans. The settler is a cylindrical pan 8 ft. diam. by 3 ft. deep, 3 times the capacity of the amalgamating pan, but of similar construction, as shown in Fig. 104. It is required to do no grinding, but to gently agitate the pulp with the wooden shoes with which it is provided. The shoes nearly touch the bottom of of

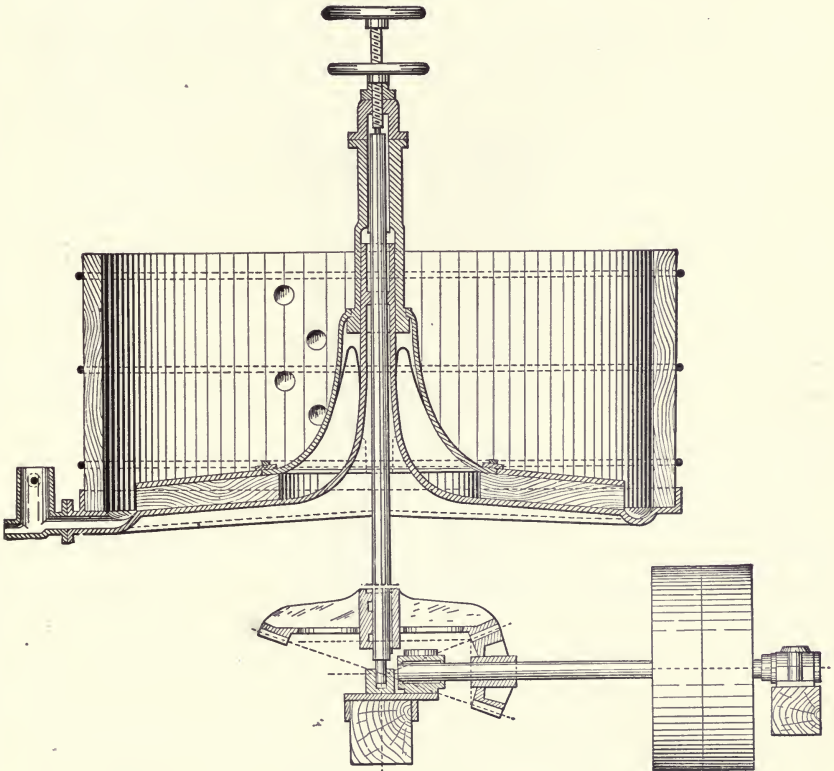

Fig. 104. EIGHT-FOOT SETTLER.

the settler, the exact height being adjustable. The grooved border at the bottom just within the sides of the settler has a slight grade to the outlet and mercury-well at the left. The mercury settles from the pulp, flows to the lowest point and stands at a height that balances the hydrostatic head of the content of the pan. Since the specific gravity of mercury is 14 and the content of the settler approximately 1.5 the height of the mercury is a little less than 4 inches. The bottom outlet-hole of the well is plugged. At

different heights in the side of the pan there are provided openings that are kept closed by plugs. When the plugs are withdrawn the tailing and water, free from mercury, passes out of the pan.

The shoes of the settler having been set in motion, at the rate of 15 rev. per min., and raised 8 in. above the bottom, the contents of the two pans are run in, as has been described. Water is then added to within 6 in. of the top, greatly thinning the pulp, and filling the settler. After half an hour the shoes are gradually lowered until, at the end of two hours, they nearly touch the bottom. The purpose of the agitation is to keep the lighter portion of the ore (now called the tailing) in suspension, while the silver-bearing mercury, the heavier particles of sulphide, and the particles of iron from the stamps collect at the bottom. The stirring is continued $3\frac{1}{2}$ hours, after which the highest plug in the side of the settler is removed, and the turbid water containing tailing is allowed to escape by launder, a stream of clear water being meanwhile allowed to flow through. The plugs are then withdrawn one by one until the settler is emptied of all the content except the heavy portion containing sulphide, iron particles, and the mercury. Emptying takes half an hour, and the cycle of operations becomes six hours as in the case of the amalgamating pan. Since escaping tailing contains sulphide, it may be run over riffles, or blanket-lined launders, before running to waste. In Fig. 109 is seen a system of pans and settlers.

The silver-bearing mercury or diluted amalgam, a mixture of silver-amalgam and mercury, collecting in the mercury well, overflows by an escape-opening indicated in Fig. 104. From the opening it passes by a half-inch pipe to the amalgam safe shown at the right of the settler, Fig. 102. The safe, arranged to prevent theft of the amalgam, is shown on a larger scale in Fig. 105. The amalgam and mercury enter a conical canvas sack or filter. The mercury oozes through the pores of the canvas while the amalgam containing as little as 14% silver is retained. Occasionally, after amalgam has accumulated, the sack is squeezed between the hands to remove the surplus mercury, and the compressed amalgam containing 20 to 28% silver, is reserved for retorting. The mercury flows out at the bottom through an outlet provided, as seen in Fig. 105, and is collected at a lower level in the boot *w*, Fig. 102, of the mercury elevator, shown at the right. The elevator discharges to a mercury tank *s* commanding the amalgamating pans, to which it is delivered as needed through pipe shown in the figure. Over the stamps and the pans are seen the overhead tracks that carry

crawls by which the heavy parts of the machines are lifted or transferred. This facilitates the work of repairs and replacements.

The loss of mercury is commonly 1 to 1.5 lb. per ton of ore treated. A part is lost in handling, but the principal cause of loss is the flouing which causes the mercury to escape in the tailings. The loss is greater with talcose or clayey ores, and in those carrying cerussite, chalcopyrite, or galena. Loss is caused by grease coating the particles of mercury, in case this enters the ore from the machinery.

Treatment of the amalgam.—Since the weight of metal recovered in silver milling is much greater than in gold milling, the retorting

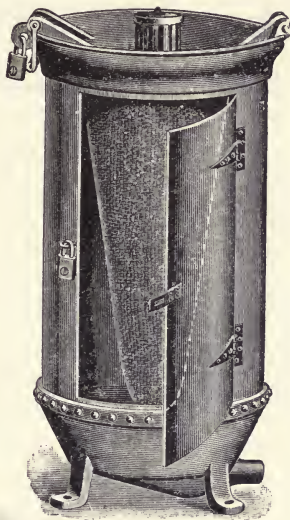

Fig. 105. AMALGAM SAFE.

of amalgam must be performed on a larger scale. Fig. 106 shows a sectional elevation and a plan of a combined retorting and melting furnace with the overhead crawl and chain-blocks by which the large melting crucibles are lifted from the fire in the melting furnace and transferred for pouring. At the left is shown in the elevation a cross-section of the cast-iron cylindrical retort which is 10 in. diam. inside by 28 in. long, resting upon arched cast-iron supports. There is a horizontal pipe, and, not shown in the illustration, a vertical water-cooled pipe in which the mercury condenses and from which it falls into a tub of water below. As seen in the plan, the front end of the retort is provided with a cover which can be securely clamped in position.

The charge of amalgam, containing 20% mercury, should weigh 500 lb. and only half fill the retort. After filling, the cover is clamped on, first luting the joint with flour paste. A wood fire is started on the grate under the retort. The temperature is kept

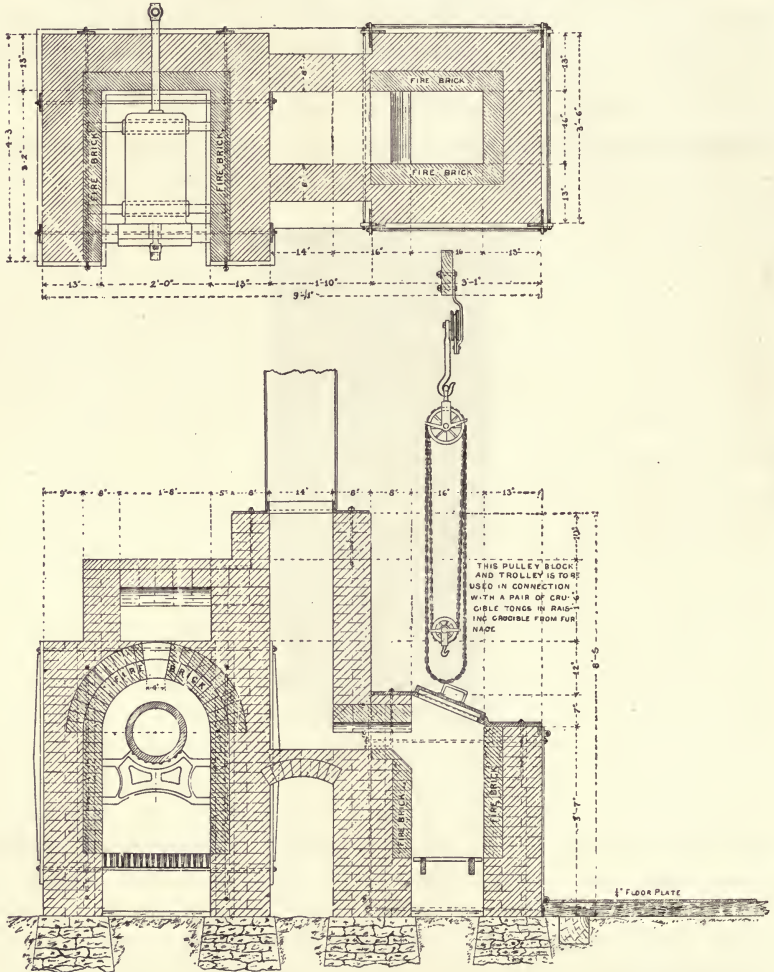

Fig. 106. HORIZONTAL RETORT AND MELTING FURNACE FOR SILVER MILL.

low at first, increasing to a red-heat at the end, $\frac{2}{3}$ to $\frac{3}{4}$ cords of wood being used. The operation lasts 10 to 14 hours, care being taken not to heat the retort rapidly, nor, for fear of blistering it, to raise the temperature too high. The fire is then allowed

to burn down, and the retort to cool. The lid is taken off and the silver residue removed.

The melting of the residue is performed in plumbago crucibles, adding soda and borax as fluxes. The crucible is set in the wind-furnace (shown in Fig. 106) at the right and supported upon a brick resting on the grate-bars. It is surrounded with coke which burns by natural draft, the smoke escaping by the flue at the back to the stack. When the charge is melted the crucible and contents are removed from the fire with basket-tongs, which fit the crucible and clasp it firmly so that it can be lifted by the chain-hoist, transferred by the crawl to the ingot, and poured. These molds, 11 in. long by $4\frac{1}{2}$ in. wide and deep, hold 1000 oz., or 70 lb., silver.

The settler tailing contains heavy unaltered ore which it may pay to concentrate on a Frue vanner of some similar table. At some places, sluices are used, two or three in parallel. These may be 2 in. high, 20 in. broad, and 1800 ft. long. The bottoms of the sluices are covered with coarse blanketing which can be easily removed and washed to recover the concentrate or particles of amalgam that settle into the meshes of the blankets.

Costs.—The cost of pan-amalgamation with tank-settling (Washoe process) per ton of ore treated is:

Power	\$0.087
Labor	0.361
Chemicals (salt, acid, bluestone).....	0.465
Loss of mercury	0.750
Wear of pans	0.200
Wear of dies and shoes	0.400
Oil, interest, and superintendence	0.100

Total cost per ton..... \$2.363

One notes in particular the larger cost of supplies (chemicals, mercury, and castings) compared with like items in gold milling.

55. THE BOSS PROCESS OF SILVER MILLING.

This system, originated by M. P. Boss, a California engineer, differs from the Washoe process in being continuous and generally requiring less labor. However, the Allis-Chalmers Co., have designed—for the Washoe process—a wet-crushing mill in which the settling-boxes have sloping bottoms, so arranged that the content is transferred to the pans with but little labor. This takes away

the advantage urged in favor of the Boss system. It may be added that the settling of the pulp in large tanks, combined with a mechanical system of excavating the content as in the cyanide process, ought to be efficient and labor-saving.

The Boss system may be applied to free-milling ores and to rebellious ores that need to be first roasted.

Fig. 107 is a sectional elevation and Fig. 108 a plan of a 30-stamp mill arranged according to the Boss system. Fig. 108 shows that the ore, coming in by two tram-tracks, is dumped over grizzlies, the fine falling into the storage bins, while the coarse ore falls upon a

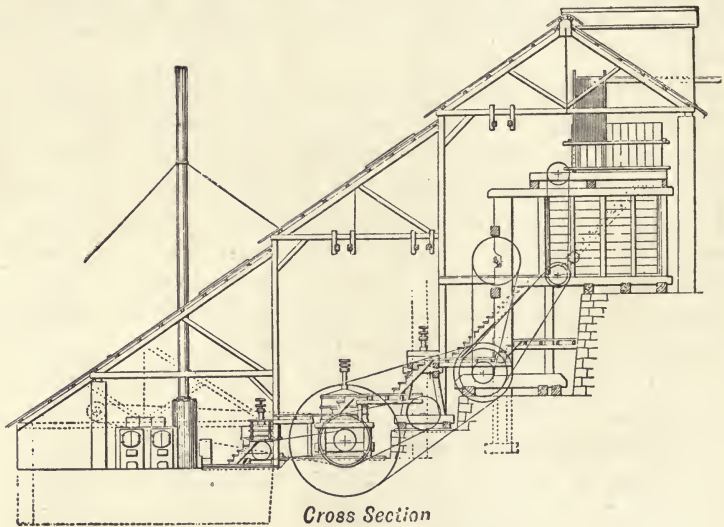

Fig. 107 BOSS-PROCESS SILVER MILL (ELEVATION).

feed-floor between them. Here the coarse is crushed in a Blake crusher, discharging to the storage bin below. From the bins the ore is fed automatically to the stamps, and wet-crushed. The screen-discharge from each ten stamps flows through pipes to a pair of 4-ft. grinding-pans in series or six pans in all (shown in the plan, Fig. 108) where the ore is finely ground. It overflows from the top of the second pan into a common launder and is carried by pipe to the next series of pans at a lower level, flowing continuously through the line of pans and settlers there situated. There are ten amalgamating pans and four settlers. They are connected one to another near the top by 4-in. nipples, which permit the flow of a pulp that is thinner than that in the tank system.

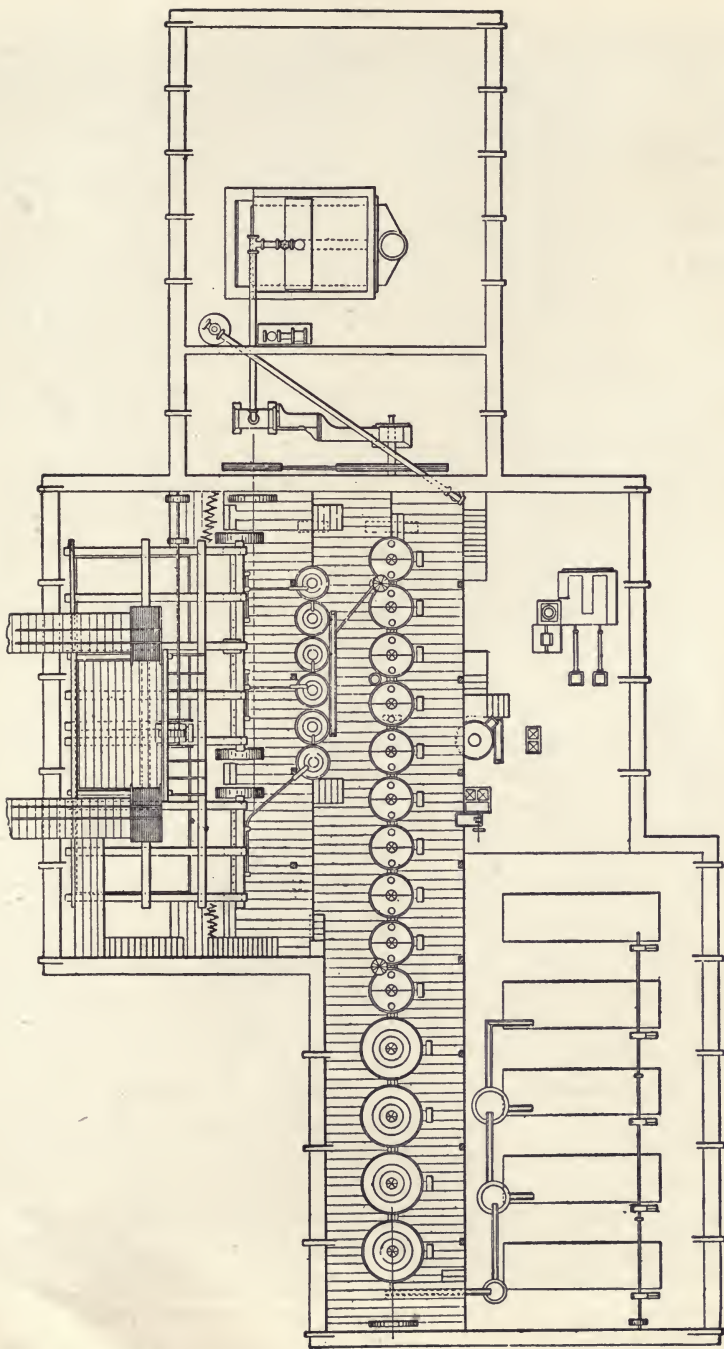

Fig. 108. BOSS-PROCESS SILVER MILL (PLAN).

The amalgamating pans are provided with double bottoms for the admission of exhaust steam from the engine, to heat the pulp as in the tank system. The chemicals are fed continuously to the first two pans in the series by two 'chemical-feeders,' and the mercury also is supplied continuously to all the pans by pipes leading from the mercury distributing tank. Whatever mercury settles in any of the amalgamating pans, or in the settlers, is collected in the mercury well of each, and the overflow from all the wells flows through suitably arranged pipes to the strainer. The strained mercury is elevated to the distributing tank to be again used. The continuous flow from the last settler goes to three settling cones in series. The spigot-discharge from each cone goes to a separate table, and the overflow to a fourth one. The fifth table is used for re-treating the heads of the first four.

Steam siphons are provided for cleaning out the pans, or for carrying the pulp past any pan when necessary to cut out the pan for repairs. The main line shaft runs directly under the pans and settlers, each of which is driven by a friction clutch. Thus any machine may be stopped in case of an accident, or for cleaning, without having to stop the whole line. All the battery-flow, including the slime, must pass through the system, and no ore passes untreated as in the tank system. The loss of mercury is small and it is possible to correctly sample the tailing, which are advantages over the older system. In spite of the thin pulp used it is claimed that an ore adopted to pan-treatment can be more successfully worked by the continuous system.

56. THE COMBINATION PROCESS OF SILVER MILLING.

This process is used on ores carrying silver, gold, and sulphides of the heavy metals, such as galena, blende, and pyrite, and sulphides which contain silver and gold. It is necessary that the silver, not in the sulphides, be amalgamable, as is silver chloride, argentite, or native silver.

The process consists in wet stamping the ore, running the pulp over apron plates as in gold milling, concentrating the sulphides, and, as in the Washoe process, pan-amalgamating the tailing and treating the amalgam to recover the silver and gold.

Compared with either wet or dry silver-milling the process has much to commend it. The ore being refractory, the wet process would recover little value. The tonnage stamped by the dry-method with roasting would be low compared with wet-stamping which is one-and-one-half to twice as rapid. It is true that by dry-stamping

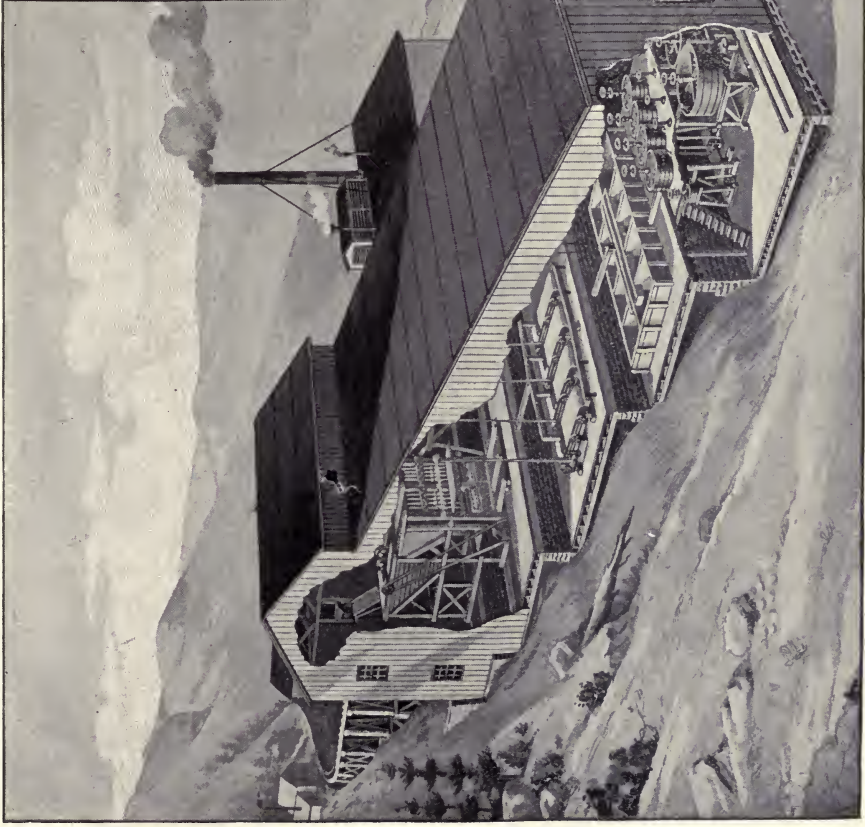
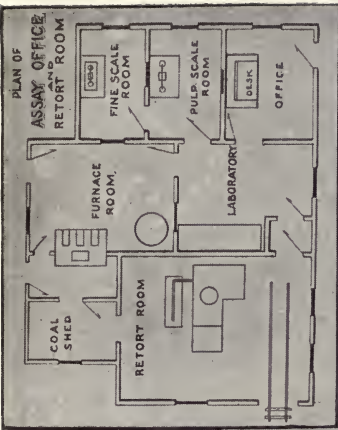

Fig. 109. COMBINATION STAMP-MILL.

and roasting we are able to extract at least 10% more metal than can be obtained by raw amalgamation, but this is offset by the cost of treatment and the loss of precious metal in roasting. The combination process also saves lead and removes galena, sulph-arsenides, and sulph-antimonides, all of which tend to foul and cause the loss of mercury. Such minerals are not amenable to amalgamation, and by removing them for separate treatment there results a cleaner or higher-grade bullion. Manganese minerals that consume chemicals in the pan are also removed by concentration. Because of the advantages, it is probable that the field of the combination process will extend. Certainly it will be used in preference to roasting and amalgamation, a method rapidly losing ground; and in some instances it may take the place of lixiviation, so far as respects the pan-amalgamation feature of the treatment.

The combination mill.—Fig. 109 is a perspective view of a 10-stamp combination mill. It shows at the left a tram-car on the upper stage which is about to be emptied over the grizzly. The fine falls through the grizzly while the lumps fall upon the feed-floor and are shoveled into a Blake crusher, crushed to 1-in. size, and united with the fine in the inclined bottom storage-bin below.

Let us suppose we are to treat an ore, in part oxidized, but containing the heavy minerals of lead and copper, with pyrite, arsenides, and manganese minerals. The ore contains the precious metals, a gangue of quartz, calcite, and a little clay, and disseminated through it gold and the amalgamable silver minerals cerargyrite, argentite, and native silver. The purpose is to save the precious metals by plate and pan-amalgamation, and the heavy minerals with silver and gold by concentration. Some of the silver and gold escapes recovery and is lost in the tailing. Since sulph-arsenides and manganese minerals are mostly removed, they do not interfere with subsequent pan-amalgamation where arsenic would sicken the mercury and manganese consume chemicals.

The ore and water are fed automatically to a ten-stamp battery, each stamp crushing 4 tons per 24 hours to pass a 30-mesh screen. The pulp issuing from the mortar flows over two apron-plates (one for each 5-stamp mortar) and a part of the gold and silver is recovered. The flow is distributed evenly to four Frue vanners at a lower level, the concentrate (10% of the whole) being separated to ship to smelting works, while the tailing is carried to the ten settling boxes in a double row. These are seen at the left of the pans. The distribution is into a double launder between the

two rows. By drawing the plugs in the bottom of the launder, the flow can be directed into any box desired. From this point on, the operation is conducted as described for the Washoe process. There are four amalgamating pans and two settlers. Bluestone and salt are used to decompose the argentite. Mercury or amalgam escaping the apron-plates finds its way into the settling boxes and thence to the pans, and is more thoroughly recovered than would be possible if the recovery depended upon obtaining it in the vanner concentrate as in gold milling. The four 5-ft. combination grinding and amalgamating pans each treat 3000 lb. per charge, and with a 4-hour treatment, this equals 36 tons daily, which with the 4 tons of concentrate already mentioned is a 40-ton output of the mill. Some ores, not so readily treated, take 6 to 8 hours, and lessen the capacity of the mill accordingly.

The recovery of precious metals in a certain ore, containing 0.40 oz. Au and 9 oz. Ag per ton, was as follows, stated in percentages:

	Gold	Silver
Recovered on the apron plates.....	22	3
Recovered on the Frue vanners.....	28	32
Recovered in amalgamating pans....	32	35
Lost in the tailing.....	18	30
	100	100

The total recovery of the gold was accordingly 82%, and of the silver 70%. Of the lead and copper 85% was saved in the concentrate. The tailing contained 0.1 oz. Au and 3 oz. Ag per ton. Concentrating adds but little to the cost of the pan amalgamation, and \$3 per ton may be taken as a fair estimate of the cost of combination milling.

57. CHLORIDIZING ROASTING OF SILVER ORES.

Silver ore containing sulph-arsenides, sulph-antimonides, or tetrahedrite, cannot be treated directly by amalgamation nor by any of the lixiviation methods. Such ore must be subjected to a roast with salt to convert the silver into a chloride, before it can be successfully treated by any of these methods. The above minerals are often accompanied by pyrite, blende, chalcopyrite, and galena.

Preliminary to roasting, such ore is dry-crushed, either by rolls or by stamps. Ores containing galena and blende are preferably crushed to 40-mesh size, those having pyrite to 8 to 10 mesh. The roasting is done in a reverberatory furnace, and requires

the use of salt. There must also be 3 to 8% pyrite present to furnish sulphur for the reactions, and if the ore does not contain this, it must be added. If more than 8% sulphur is present, the percentage is reduced to that point by roasting afterward, before the salt is added. The amount of salt required varies according to the quantity of copper and iron sulphides present which consume the evolving chlorine.

The roasting operation is at first an oxidizing one conducted at the temperatures specified in the chapter on roasting. The action is chiefly upon the heavy metals, converting them into either oxides or sulphates. It may be divided into three stages (1) the kindling, (2) the desulphurization, and (3) the chlorination of the ore.

In the first or kindling stage we find the loosely held sulphur being driven off, and the ore taking fire, producing a blue flame.

In the second stage, the air oxidizes the sulphides, and particularly the newly formed iron sulphide. Reacting upon the sulph-antimonides and arsenides, it volatilizes them and removes them from the ore. Copper and iron sulphates are also formed, the later according to the following reaction:

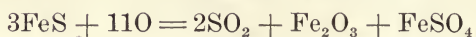

In the third stage, at 590° C., the sulphate formed, reacts upon the salt, thus:



The odor of sulphur dioxide and chlorine is pronounced. The chlorine thus liberated acts at once upon the silver compounds and converts them into chlorides.

Zinc blende becomes oxide and zinc sulphate, while sulphur dioxide escapes. Galena and zinc sulphate remain inactive and fail to decompose the salt. They roast slowly, while pyrite, in presence of salt, decomposes quickly, and generates chlorine at a period in the roasting when neither the blende nor galena are sufficiently oxidized to expose silver to the action of the chlorine. If therefore the salt is mixed with the ore at the battery, the chlorine generated by the reaction of the ferrous sulphate and salt is lost, an imperfect chlorination results no matter how long roasting is continued, nor how much salt is added. Hence in roasting an ore containing blende and galena it is of the greatest importance to add the salt later and not at the battery. On the other hand if the roasting continues until the sulphides are well oxidized, the iron sulphate decomposes and no chlorine is generated

and again we have a badly chloridized ore. The desirable time to add the salt is after continued roasting at a low heat that does not break up the iron sulphate. This is shown when the black color of the ore changes to brown, but shows still the presence of black particles. A distinct odor of chlorine is then to be noticed, due to the decomposition of the salt. The best results could be obtained by adding a mixture of green vitriol (ferrous sulphate) and salt; but the ore would hardly justify the expense. For moderate quantities of ore, the chloridizing roast is performed in reverberatory furnaces. For large quantities, roasting is cheaper when conducted in the mechanical roasters.

The salt is added to the dry ore at the time of charging, if the percentage of sulphur is suitable, or later if the excess of sulphur must be first removed by roasting. The temperature is increased only gradually to kindle or start the ore to burning and to begin oxidation. As the temperature rises oxidation and the formation of sulphates occur, and at the necessary high temperature these act upon and decompose the salt and chloridize the ore.

It is not considered necessary to continue the roasting to convert all possible silver into chloride, but to withdraw the charge while hot before this stage is reached. During the gradual cooling (12 to 30 hours) further chloridizing proceeds, due to the action of the free chlorine, with which the ore is saturated, acting on the undecomposed silver sulphide. This may increase the chloridization 10 to 40 per cent.

Upon completion of the operation of 'heap chlorination', as it is called, and with ores containing copper chloride, a wetting down or sprinkling causes an additional chlorination of 3 to 6%. Thus at the Lexington mill, Butte, Montana, the ore, after roasting in a Stetefeldt furnace was chloridized to 65% after two hours in the heap to 75 or 80%, and at the end of 36 hours to 92% of the silver content.

The loss in silver by volatilization, when the ore has been properly and carefully roasted, should not exceed 8% except in presence of volatile elements like arsenic, antimony, selenium, or tellurium. If, however, the roasting is completed at a high temperature the loss may rise to 18 per cent.

The most difficult, and at the same time the most important process for the treatment of silver ores by wet-methods, is undoubtedly chloridizing roasting. It is always the safest plan for the operator to roast as thoroughly as possible. If the ore is well chloridized sodium hyposulphite extracts all the silver chloride.

A high chloridization does not necessarily involve a high loss by volatilization.

58. DRY SILVER-MILLING (REESE RIVER PROCESS).

This process for the treatment of rebellious silver ores, in which the metal is so locked up as to require roasting before it can be amalgamated, was developed at Reese river, near the Comstock Lode at Virginia City, Nevada. The ore contains silver sulphide, particularly the antimonial sulphides, and the sulphide of the base metals such as copper, iron, zinc, and lead. Galena, however, if present exceeding 5 to 10%, renders the ore unsuitable for chloridization.

The treatment in brief consists in dry-crushing and roasting the ore, then amalgamating in pans to recover the silver and gold. The dry-crushing is done either with rolls or stamps. Crushing with rolls is described in the chapter on 'Crushing.' If dry stamping is employed the work is done in the dry-crushing silver mill, Fig. 110 and 111, here described.

Fig. 110 is a sectional elevation, and Fig. 111 a plan of a 20-stamp mill. The ore is dumped from the tram-car over the grizzly *b*, which separates the fine from the lumps which roll to the mouth of the crusher *c* and are crushed to $1\frac{1}{4}$ -in. size. The crushed product falls with the fine into the storage bin *d*. From this the ore is fed continuously throughout the 24 hours by means of an automatic feeder *e*, which supplies a revolving drier *f* that is 18 ft. long. The drier is provided with a fire-box *g*, the smoke passing through a flue to a separate stack. Flue-dust is retained in the flue.

The ore from the drier containing less than 1% moisture, slides by an inclined launder or feed-chute to the automatic feeders *i* of the stamps. The fine particles drive through the screens, while the coarse part drops back upon the die to be further crushed. Naturally the process produces dust, and to prevent escape into the mill, the mortar is housed or boxed. There is also an exhaust-fan connected with the housing by which the dust is drawn to a dust-chamber and settled. The finely ground ore passing through the screens, drops to the screw-conveyors, one at the front of the other at the back of the mortars, and is conveyed by them to the hopper or boot of the belt-elevator *k*.

It is customary to feed into the last battery the rock salt required by the ore. Being finely crushed it can be intimately mixed with the ore. The elevator raises the mixed ore and salt to the conveyor *m*. Thence the screw conveyor *n* delivers it into the

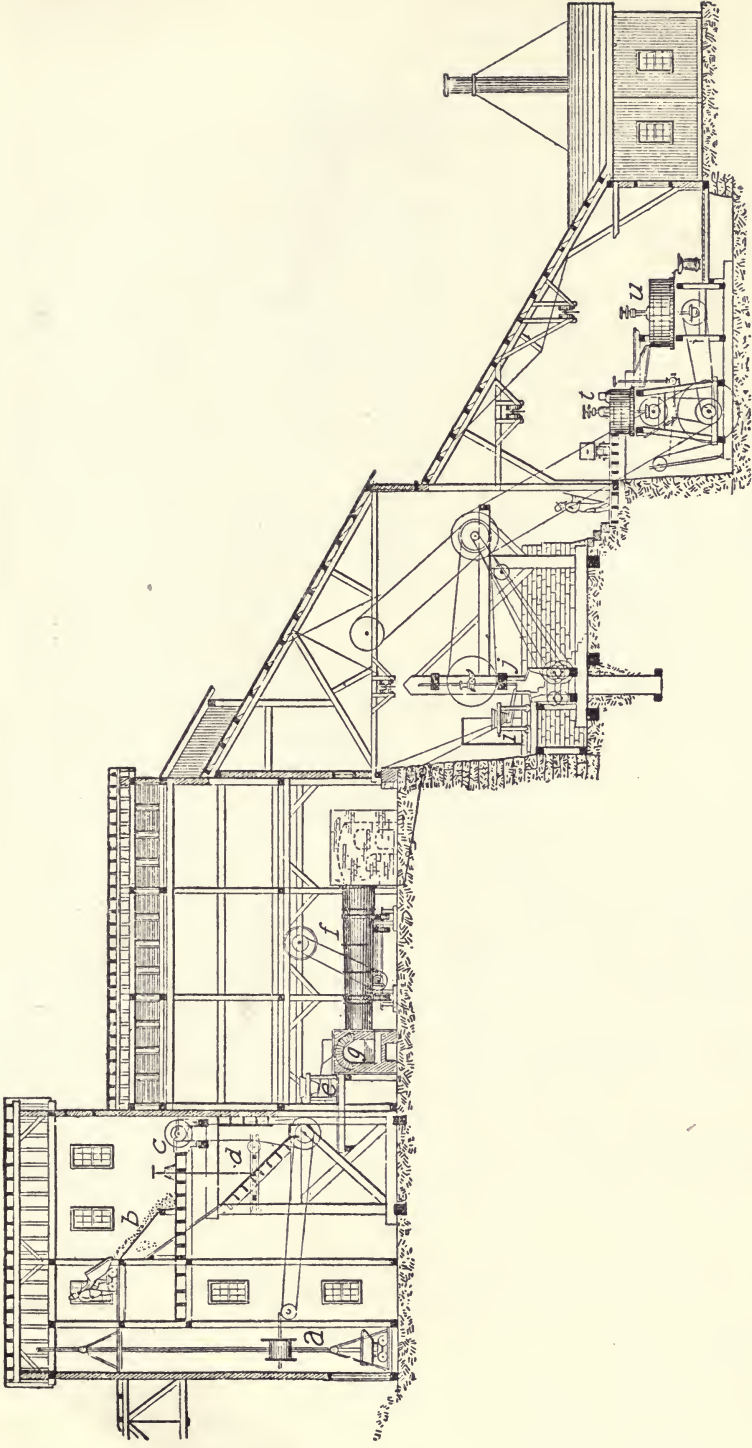

Fig. 110. DRY-CRUSHING SILVER MILL (ELEVATION).

hopper of the roaster. (In Fig. 194 is shown the manner in which the transfer from *m* to *n* is effected, the delivering conveyor being shown at the right, and the receiving one at the left.) From the feed-hopper the ore slides into the White-Howell roasting furnace *o* (See also Fig. 34), where it receives the chloridizing roast.

In the plan of the mill, Fig. 111, is to be seen the flue-chamber, and a stack like that for the ore-dryer. In the chamber the dust produced in roasting settles and is recovered. The roasted ore, discharged from the roaster, is received into one of the hoppers *r*. When either hopper is filled, the content is drawn off, moistened with a little water to prevent dusting, and stored on the cooling floor *s*. The level of the floor *s* is slightly above that of the pan-floor where the man in Fig. 110 is seen standing. The tracks on the pan-floor-level are arranged so that a tram-car can take the ore from the cooling floor to any of the ten amalgamating pans *t*.

The amalgamation of roasted ore is performed in pans having wooden sides (See Fig. 103.) as in the Washoe process. Water is run into the pan first, and while in motion, the 3000-lb. charge of ore is shoveled in until the pulp is of the consistence of honey. If the ore is imperfectly roasted, salt and bluestone are added to decompose the silver sulphide. The free chlorine in the ore would be consumed by contact with the iron surfaces of the pan, and hence the wooden sides are provided. After a time, the iron particles that have come from the stamps are thus removed and prevented from acting upon the mercury and converting it to mercury chloride in a way that would be detrimental to the process. When the ore has been ground two hours the shoes are raised about half an inch from the dies, and 300 lb. mercury is added. If mercury were added during the grinding it would flour seriously. The shoes and muller intimately mix the pulp and mercury. Amalgamation proceeds rapidly at first, but more slowly toward the last, the silver chloride being reduced to metal as in the Washoe process. The iron present reduces the higher chlorides of copper and iron, and precipitates mercury from the mercurous chloride. The mixing is of six hours duration. Water is added and the entire content of the pan is run into the settlers *u* Fig. 111. Here it is diluted with water and the mercury and amalgam settled. The tailing is decanted, and the amalgam is recovered and treated as described under the Washoe process.

The recovery of silver is thorough, being in some instances 97%. The loss of quicksilver is slight, being less than $\frac{1}{4}$ lb. per ton of ore. At the Lexington mine, ore containing 28.5 oz. Ag and

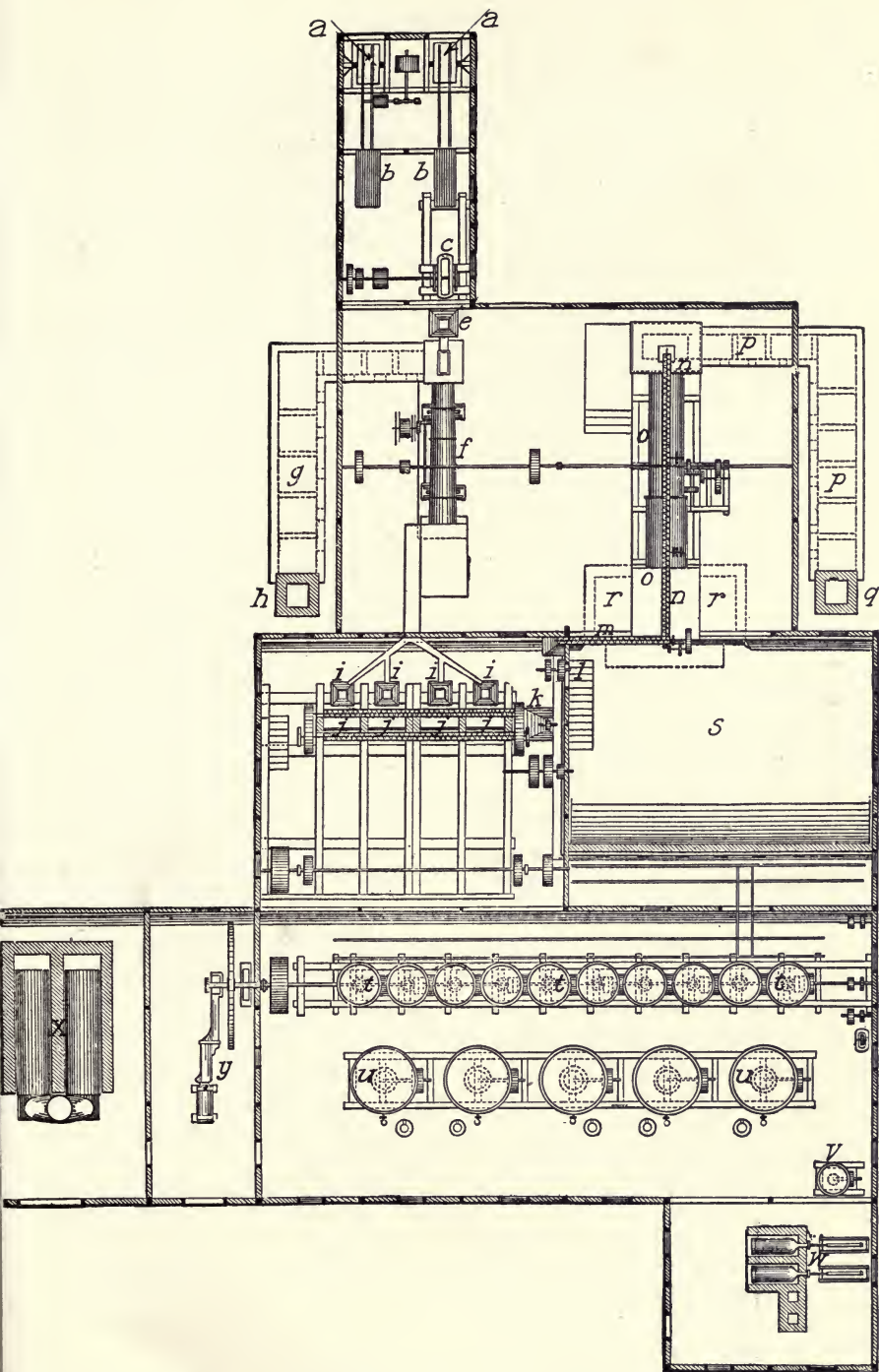

Fig. 111. DRY-CRUSHING SILVER MILL (PLAN).

0.58 oz. Au per ton yielded 93.3% of the silver and 60% of the gold after roasting. The loss of silver in roasting, however, was 7%, and that of gold 20%. This gives in actual recovery, 86.8% of the silver, but only 48% of the gold.

The cost of dry stamping followed by chloridizing roasting may be considered \$6.48 per ton of ore treated, this being an average of results in three mills that vary but little from one another, situated in different parts of the Rocky Mountain country.

Upon comparing the recovery at the Lexington mine with one of 60% of the silver and gold as obtains by direct amalgamation of the raw ore, we have, with the price of silver 60c. and of gold \$20.65 per ounce, the following result:

	Raw	Roasted
Treatment	\$2.46	\$6.48
Loss of silver	6.84	2.14
Loss of gold	4.79	4.79
	\$14.09	\$13.41

It is seen in the extraction represented, that there is but little advantage in roasting over the raw treatment of ore of this grade, to say nothing of the extra cost of installing a roasting plant, and the large mill needed for the tonnage. Of course, in case ore is so refractory that only a low extraction of metal is possible, a chloridizing roast may be the alternative.

While rebellious ores have been worked by dry silver-milling, it pays in many cases, where accessible to smelting-works, to ship ore rather than to mill it. If the heavy part of the ore carries most of the value, it is better to concentrate it and submit to the loss in the tailing to gain the advantages of treating a concentrated ore. Such problems are solved on a trial scale before undertaking the erection of a plant.

Comparing dry silver-milling with smelting, where the smelter pays for 95% of silver and for the gold at \$19.50 per ounce, and makes a freight rate of \$5 and a treatment rate of \$8 per ton we have the following condition:

	Smelting	Dry Silver-Milling
Treatment	\$8.00	\$6.48
Freight	5.00	
Loss in silver	0.86	2.14
Loss in gold	0.67	4.79
	\$14.53	\$13.41

This indicates a gain of \$1.12 in favor of roasting-amalgamation over smelting.

On the other hand the cost of erecting an expensive plant is saved by shipping the ore to the smelting-works as is today generally done.

59. SILVER MILLING AT BLACK PINE, NEVADA.

The ore of the Combination Mining & Milling Co., at Black Pine, Nevada, contains silver in malachite and tetrahedrite, with a quartz gangue, and no lead or zinc minerals. The process consists in milling and concentrating the ore to separate the refractory tetrahedrite from the free-milling malachite and roasting and pan-amalgamating the concentrate.

The ore is partly sorted underground, and upon hoisting, dumped over grizzlies in a rock-house, the fine falling into a hopper-bottom bin, to be thence hauled by team to a sloping bottom storage-bin near the mill in which a good supply can be carried. From this bin the ore is trammed to the mill, and dumped over a grizzly with one-inch openings to separate the fine. The coarse ore falls to the mouth of a 10 by 20-in. Blake crusher running 250 rev. per minute. The crushed product joins the fine in the mill storage-bin as described in connection with Fig. 102. All the foregoing operations occur in the day shift.

From the mill storage-bin the ore is fed by automatic feeder to a 20-stamp battery, having 1100-lb. stamps dropping 6 to 9 in. 100 times per minute. It is crushed through 30-mesh brass-wire screens at the rate of 3.75 tons per stamp in 24 hours. The battery-pulp is carried by launder to a belt elevator which raises it above the level of the Frue vanners. The pulp is discharged into a distributing box and thence to the twelve vanners of 6¼ tons daily capacity each of 75 tons total capacity. With a concentration of four into one, there is obtained nearly 20 tons of concentrate containing the refractory tetrahedrite needing chloridizing roasting, and 55 tons of free-milling tailing containing malachite. The tailing is settled as in the Washoe process (See Fig. 102 and 109) in a series of 18 tanks, each 9.25 ft. long, 6.5 ft. wide, and 2.75 ft. deep.

The settled pulp is shoveled from the tanks to the floor adjoining. It is fed as needed into 14 wooden-sided, 6-ft. amalgamating pans, the charge consisting of 3000 lb. tailing and 1000 lb. concentrate that has received a chloridizing roast to be described. To the charge is added 300 lb. mercury to amalgamate

the silver, 17 lb. salt to react with the copper salts present and decompose silver sulphide, 8 to 16 lb. iron filings to decompose chlorides, and 1 lb. lye to correct any acidity of the ore. The iron filings react as follows:

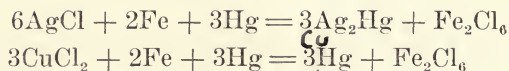

Without the iron, mercury chloride (HgCl_2) would be formed and lost in the pan-tailing. Silver and copper chloride are accordingly decomposed and the metals amalgamated.

The amalgamation is completed in eight hours, then the content of a pan is run into an 8-ft. settler 39 in. deep, of which there are seven. The settler is run at 20 rev. per min. and the charge, now diluted with water, is worked off in four hours, one settler treating the output of two pans. At the side of the settler near the top is a rectangular overflow notch 3 in. deep, and at distances of 8, 14, 21, and 25 in. down are 3-in. plugs. The pan, having been for an hour in motion, decanting separated pulp and water, the first plug-hole from the top is opened. After another hour the second plug is withdrawn and decantation continued two hours longer, the sand in the settler below the second plug remaining until the periodical cleaning out. The plug-holes are now closed, and the pan is ready for another charge. The exhausted tailing is conveyed to a settling pond and impounded behind a crib-dam thrown across the canyon below the mill.

The mercury.—From the mercury-well at the side of a settler (See Fig. 104), the mercury overflows to an amalgam safe (See Fig. 105). After straining through the canvas filter-sack inside the safe, it drains to the foot of a 4-in. belt elevator provided with cast-iron cup-buckets. This raises and delivers it to a mercury storage-tank where it is reserved until again used. This arrangement of settler, safe, elevator, and tank, is well shown in Fig. 102.

To remove mercury chloride which causes mercury to flour and fail to coalesce, one pound of sodium is stirred into 16 lb. mercury and added to the mercury supply every two days. The sodium reacts as follows:

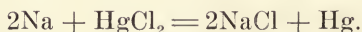

The NaCl then dissolves in the water. Eight pounds of potassium cyanide also is added weekly, the cyanide reacting upon the mercury chloride thus:

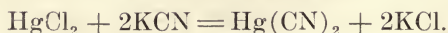

The KCl passes into solution. The mercury cyanide is soluble in the mercury and adds to its activity.

Treatment of amalgam.—The amalgam removed from the canvas strainers is often dirty and must be sent to a clean-up pan to remove the waste-matter before retorting. It is placed in the pan for cleaning, ground, settled, and the sand and dirty water decanted as from a settler. The amalgam thus formed is again put through a strainer, and the cleaned amalgam sent to the retorts.

Retorting.—From 75 tons of 25-oz. ore there comes 1600 oz. silver or 12,800 oz. coppery bullion 125 fine. This corresponds to 64,000 oz. or 4400 lb. amalgam of 20% Ag. There are four retorts, each capable of holding 1600 oz. amalgam. The amalgam is charged to the retorts, Fig. 106, the covers luted on, and the retorting conducted in 8 to 10 hours. A jacket (See Fig. 54) that surrounds the condensing tube, is supplied with cold water under pressure. The mercury-fumes thus condensed are caught in a tub containing water.

Melting the residue.—This is done in an efficient way in a small reverberatory furnace, which is first heated to a bright-red heat. The furnace is charged with 4400 lb. retort residue, upon which when melted is thrown in 20 lb. each of borax and nitre to act as a flux. The bath is then thoroughly stirred and two samples for assay taken with a long-handled spoon, and granulated by pouring into water. Brass molds, holding 100 lb. each, placed close together on a carriage, and painted with a mixture of lamp-black and benzine, are brought beneath the furnace spout and the bullion tapped into them, the carriage being moved along as the molds are successively filled.

Roasting the concentrate.—The concentrate amounts to 20 tons daily. It is trammed to the roaster-room and emptied on the floor above the Bruckner roaster. The charge is shoveled into the cylindrical roaster, which is revolved 15 minutes for the ore to dry. Then 10% salt is added, and if there is not sufficient sulphide in the ore sulphur is added to increase this to 5%. The charge is now fired and the temperature gradually raised, dense grayish-white arsenical and antimonial fumes being evolved. Next, with increasing heat, SO_3 escapes, while the presence of CuSO_4 is indicated by the blue copper flame. When this grows faint the chloridizing reactions begin, and a bright-red heat is maintained to the end. Both roasting and amalgamation are here simplified by

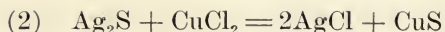

The above reaction is slow, and it is probable that the cupric chloride acts directly on the mercury as follows:

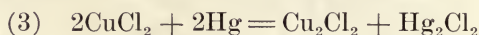

The mercurous chloride is lost.

While Cu_2Cl_2 is insoluble in water it is soluble in salt solution, and according to Laur can act directly on silver sulphide with the production of metallic silver:



61. THE HYDRO-METALLURGY OF SILVER.

A wet-process for the recovery from the ore consists in dissolving the metal by means of a solvent and precipitating from the solution in a convenient form. The silver compounds which can be obtained readily in solution are the sulphate and the chloride. In cyanide solution argentite is readily soluble, while ruby silver, freislebenite, and stephanite, are sparingly so, though readily soluble in mercurous potassic cyanide. Silver sulphate is soluble in hot water, while silver potassic chloride is dissolved by brine solution or by sodium hyposulphite (thiosulphate). From the aqueous solution of the sulphate silver is precipitated by metallic copper; from the brine solution of its chloride by copper, or when in dilute solution, by zinc iodide; from the hyposulphite solution by sodium sulphide; and from the cyanide solution by metallic zinc.

There are four well known wet-processes for the extraction of silver:

(1) The Augustin process, based upon the solubility of silver chloride in brine.

(2) The Ziervogel process dependent on the solubility of silver sulphate in hot water.

(3) The Patera process in which silver chloride dissolves in a solution of sodium hyposulphite.

(4) The cyanide process in which the silver minerals above enumerated dissolve in dilute potassium cyanide solution.

62. THE AUGUSTIN PROCESS.

This has been used for the extraction of silver from ore and from copper-bearing matte, obtained as a product of smelting. At Kosaka, Japan, ore consisting of one-half heavy spar and containing 10.5 oz. silver per ton is thus treated. The ore is crushed and roasted with salt in a furnace *b*, Fig. 112, and after drawing

from the furnace and moistening on the cooling floor, contains 80% of silver in the form of chloride. It is leached with a hot 18% salt solution in regular leaching vats *c*. The leaching is continued until a polished plate of copper shows no precipitate of silver when held in the flowing filtrate. It requires 0.66 tons of brine to leach a ton of the ore. The sand is washed with hot water, and the tailing rejected.

The brine solution from the vat *c* is received in a precipitating tank *d*. The tank, like a leaching-vat, has a false bottom. Upon the false bottom is spread a 2-in. bed of bean-copper, and on this rest plates of copper 6 by 8 in. by 1 in. thick. The silver,

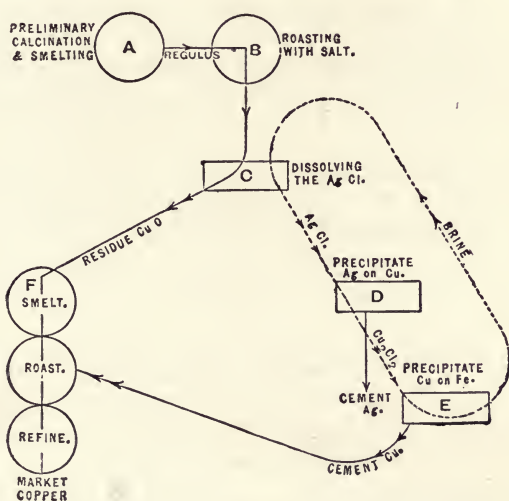
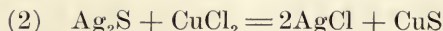

Fig. 112. FLOW-SHEET OF AUGUSTIN PROCESS.

precipitated in crystalline form upon the copper, is called 'cement-silver.' At a lower level is a tank *e* containing scrap-iron where the copper in solution is precipitated, while the barren brine goes to the brine-sump. It is there brought up to the full strength and pumped back to be again used. The cement-silver, 150 to 750 fine, is removed from the plates, squeezed in a screw-press into 'cheeses' 12 in. diam. by 3½ in. thick, dried, and refined in an English cupelling-furnace in charges of 150 lb. with 300 lb. of lead added to each charge. The refined silver, the result of the operation, is melted in crucibles and cast in bars of 1000 oz. each, 985 fine.

Treatment of matte by the Augustin process.—As indicated in the diagram (See Fig. 112) the matte after a preliminary roasting is smelted to a higher-grade matte in furnace *a*. It is then crushed,



The above reaction is slow, and it is probable that the cupric chloride acts directly on the mercury as follows:

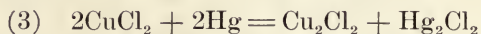

The mercurous chloride is lost.

While Cu_2Cl_2 is insoluble in water it is soluble in salt solution, and according to Laur can act directly on silver sulphide with the production of metallic silver:



61. THE HYDRO-METALLURGY OF SILVER.

A wet-process for the recovery from the ore consists in dissolving the metal by means of a solvent and precipitating from the solution in a convenient form. The silver compounds which can be obtained readily in solution are the sulphate and the chloride. In cyanide solution argentite is readily soluble, while ruby silver, freislebenite, and stephanite, are sparingly so, though readily soluble in mercurous potassic cyanide. Silver sulphate is soluble in hot water, while silver potassic chloride is dissolved by brine solution or by sodium hyposulphite (thiosulphate). From the aqueous solution of the sulphate silver is precipitated by metallic copper; from the brine solution of its chloride by copper, or when in dilute solution, by zinc iodide; from the hyposulphite solution by sodium sulphide; and from the cyanide solution by metallic zinc.

There are four well known wet-processes for the extraction of silver:

(1) The Augustin process, based upon the solubility of silver chloride in brine.

(2) The Ziervogel process dependent on the solubility of silver sulphate in hot water.

(3) The Patera process in which silver chloride dissolves in a solution of sodium hyposulphite.

(4) The cyanide process in which the silver minerals above enumerated dissolve in dilute potassium cyanide solution.

62. THE AUGUSTIN PROCESS.

This has been used for the extraction of silver from ore and from copper-bearing matte, obtained as a product of smelting. At Kosaka, Japan, ore consisting of one-half heavy spar and containing 10.5 oz. silver per ton is thus treated. The ore is crushed and roasted with salt in a furnace *b*, Fig. 112, and after drawing

from the furnace and moistening on the cooling floor, contains 80% of silver in the form of chloride. It is leached with a hot 18% salt solution in regular leaching vats *c*. The leaching is continued until a polished plate of copper shows no precipitate of silver when held in the flowing filtrate. It requires 0.66 tons of brine to leach a ton of the ore. The sand is washed with hot water, and the tailing rejected.

The brine solution from the vat *c* is received in a precipitating tank *d*. The tank, like a leaching-vat, has a false bottom. Upon the false bottom is spread a 2-in. bed of bean-copper, and on this rest plates of copper 6 by 8 in. by 1 in. thick. The silver,

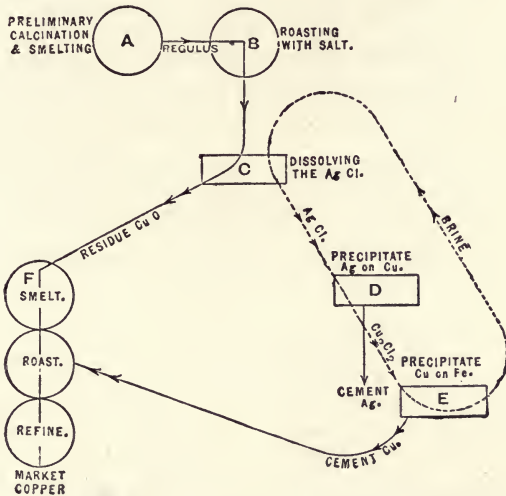

Fig. 112. FLOW-SHEET OF AUGUSTIN PROCESS.

precipitated in crystalline form upon the copper, is called 'cement-silver.' At a lower level is a tank *e* containing scrap-iron where the copper in solution is precipitated, while the barren brine goes to the brine-sump. It is there brought up to the full strength and pumped back to be again used. The cement-silver, 150 to 750 fine, is removed from the plates, squeezed in a screw-press into 'cheeses' 12 in. diam. by 3½ in. thick, dried, and refined in an English cupelling-furnace in charges of 150 lb. with 300 lb. of lead added to each charge. The refined silver, the result of the operation, is melted in crucibles and cast in bars of 1000 oz. each, 985 fine.

Treatment of matte by the Augustin process.—As indicated in the diagram (See Fig. 112) the matte after a preliminary roasting is smelted to a higher-grade matte in furnace *a*. It is then crushed,

and roasted with salt in the furnace *b*, and the roasted product leached in the tank *c*, as already described for ore. The residue from *c* cannot be rejected, as was the case with the ore, for it contains copper and iron oxides, and must be further treated by the Welsh method as described in the chapter on the metallurgy of copper. It is smelted in furnaces *f* with silicious ore and copper sulphates, producing a copper matte. The matte, in coarse pieces, is charged into another furnace from the vat *e*, and slowly melted by an oxidizing flame. The smelting is completed at a high temperature producing blister copper. This is cast in ingots or pigs, and refined in a furnace to produce market copper.

63. THE ZIERVOGEL PROCESS.

This process, practised at Mansfeldt, Germany, and at the Boston and Colorado smelting works at Argo, Colorado, is adopted to the treatment of rich copper matte containing little or no arsenic,

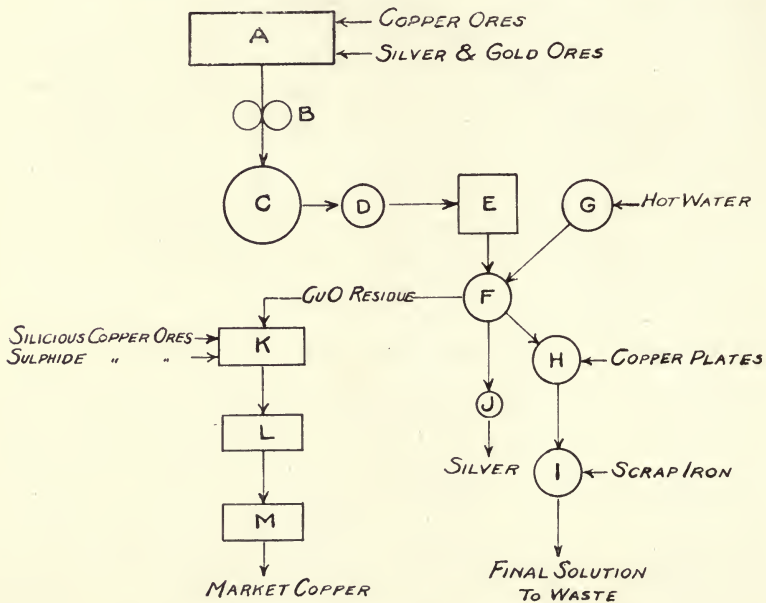

Fig. 113. FLOW-SHEET OF ZIERVOGEL PROCESS.

antimony, or bismuth, any of which would form insoluble compounds with silver. The method may be divided into three parts: the roasting for silver sulphate, the leaching, and the precipitation of the silver.

The process.—Referring to the flow-sheet of the process (See Fig. 113) we have in furnaces *a*, the operation of producing the matte or regulus from gold and silver-bearing copper ores. The details of the process are described in the chapter on the metallurgy of copper, under the head of 'Reverberatory Matte Smelting.' The composition of the matte is Cu, 47.3; Pb, 8.1; Zn, 2.7; Fe, 17.7; S, 21.6%, with 400 oz. silver and 15 oz. gold per ton.

Preparation of the matte.—The matte is crushed and passed through rolls at *b* to reduce it to 6-mesh size, and sent to a Peare-turret furnace *c* (See also Fig. 40 and 41), where it receives preliminary roasting. The roasting reduces the sulphur to 6.3%, and converts the iron and copper sulphides to the corresponding oxides and sulphates, as described in the chapter on the chemistry of oxidizing roasting. This partly roasted product then goes to a Chilian mill *d* (See also Fig. 100), where it is finely ground to 60-mesh.

Sulphatizing roasting.—The partly roasted matte is next treated in charges of 1600 lb. by a sulphatizing roast in small single-hearth reverberatory roasters at *e*. In the process the iron and copper remaining in the form of sulphides are converted into sulphates which react on the silver sulphide at a slightly higher temperature as follows:

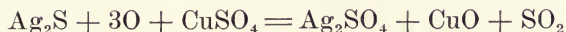

It has been found that the addition of 2% sodium sulphate (salt cake) facilitates the change. The roasting takes place in four stages as shown below.

During the first stage, of one and one-half hours, the draft is checked, the side doors kept open, and the charge held at a low temperature. The charge becomes evenly heated throughout, and glows from the oxidation of Cu_2S to Cu_2O .

During the second stage, of one and one-half hours, the heat is increased and the charge constantly rabbled. Iron sulphate is decomposed with the consequent formation of copper sulphate. The charge swells and becomes spongy by the formation of this salt.

In the third stage, of a like duration, the temperature is increased for an hour until tests show that the silver is 'out,' that is, in the form of sulphate. The following reaction occurs.

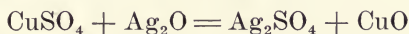

During the fourth stage the temperature is kept constant. The charge is gathered and pressed down with a heavy, long-handled, iron paddle to break the lumps, and then vigorously stirred to

oxidize the remaining Cu_2O to CuO , and decompose copper sulphate. The temperature is not further increased, since it would decompose silver sulphate forming silver oxide rendering the silver again insoluble.

The progress of the roast is tested by dropping small samples from time to time into hot water. Soluble sulphates dissolve in the hot water; and in the tests made early the solution becomes deep blue. Later, as the silver sulphate begins to form, it is immediately reduced to silver spangles by the cuprous oxide present. As the roasting advances during this stage, the copper sulphate decomposes, and the solution becomes less blue in the test and the silver spangles increase and afterward diminish. During the fourth stage the Cu_2O is changed to CuO and the spangles no longer show. A light blue color of the solution remains, due to the presence of a little copper sulphate, which indicates that the silver sulphate is not itself becoming decomposed. A sample thus roasted, showed by analysis 2.5% FeSO_4 and ZnSO_4 ; 0.6% CuSO_4 , and 1.73% Ag_2SO_4 (348 oz. silver per ton), so that there was left in the matte (there being no loss of weight in roasting matte) 52 oz. per ton or 13% of the silver in insoluble form.

Leaching.—This is performed in tanks having filter bottoms and holding 1000 lb. of matte. The roasted matte charged into the tanks *f* is leached with hot water to dissolve the sulphate above described. The filtrate goes to a series of boxes, *h*, containing copper plates upon which the silver precipitates in the form of white shining crystals. The silver-free solution, containing in addition to the original copper sulphate that which it has taken from the copper plates, goes to tanks *i* where the copper is precipitated upon scrap-iron employed to recover the copper. The final solution is rejected.

The cement-silver from the precipitating boxes is transferred to a tank and dilute sulphuric acid is added. It is boiled by forcing in a mixture of air and steam from an injector. The treatment oxidizes and dissolves the traces of copper still retained by the silver crystals, and keeps them in agitation at the boiling temperature of the acid mixture. The copper sulphate solution is run off and the residue repeatedly washed by decantation with hot water to free it entirely from copper. It is transferred to a long pan over a coal fire for drying and is then melted down in crucibles in a wind-furnace and obtained in ingots 999 to 999.5 fine.

Residue from the leaching tanks.—The extracted matte remaining

in the tanks *f*, still retaining 52 oz. silver per ton as above stated, freed from sulphates, and composed mainly of iron and copper oxides, is sent to a reverberatory furnace *k*, to form copper matte. The slag produced in the treatment goes back to the ore-smelting furnace *a*, while the matte tapped into sand molds, is sent to the reverberatory furnace *l* to be treated by the English process of making 'best-selected copper.' Here the matte, in large lumps, is piled up in the furnace near the bridge, and exposed to a flame made oxidizing by an excess of air admitted through the fire and through openings in the bridge and roof of the furnace. The effect is to 'roast' the matte as the lumps slowly melt and the drops of liquefying matte come in contact with the air. Finally the whole charge becomes melted, and the copper oxide which has been formed, acts on the unoxidized copper sulphide of the matte as follows:

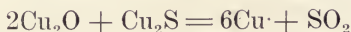

The aim is to extend the roasting only so far as to obtain in the form of metallic copper one-fifteenth of the total matte. When the charge is tapped from the furnace into the sand molds, the copper is found in the form of plates or bottoms in the first of the molds beneath the lighter matte. The bottoms absorb the impurities such as arsenic, antimony, lead, and bismuth, practically all the gold (100 to 200 oz. per ton), and some of the silver. On the other hand, the matte has risen to the grade of white-metal of 75% copper, and carries 90 to 100 oz. silver but not more than 0.2 oz. gold per ton.

To prepare it for the extraction of the silver, the matte is again given a sulphatizing roast, but in a different furnace from the one used for the first matte. The residue after this second treatment, principally a copper oxide containing 10 oz. silver per ton is sold to the oil refiners. At the Argo works the bottoms, formerly treated by a secret process for the extraction of the precious metals, is now more satisfactorily treated by the processes of electrolytic refining. (See 'The Electrolytic Refining of Copper'.)

64. THE HYPOSULPHITE LIXIVIATION OF SILVER ORE. (PATERA PROCESS.)

Hyposulphite lixiviation can be practised upon ore containing simple or compound sulphides of silver that have undergone a preliminary chloridizing roasting. The silver sulphides, in the roasting, become converted into silver chloride. The process also applies to silver ore already containing the silver as chloride. Free-

milling ore, such as oxidized ore containing the silver in the native state, or as chloride, or to some extent as argentite, are preferably treated by milling and amalgamation. Native silver and silver sulphide in a favorable form can be recovered by milling and amalgamation, whereas by hyposulphite extraction, they would remain insoluble. The process is not suited to the treatment of gold ore. The extraction of gold is slow; usually less than 50 to 70%. One of the most useful applications is to the treatment of

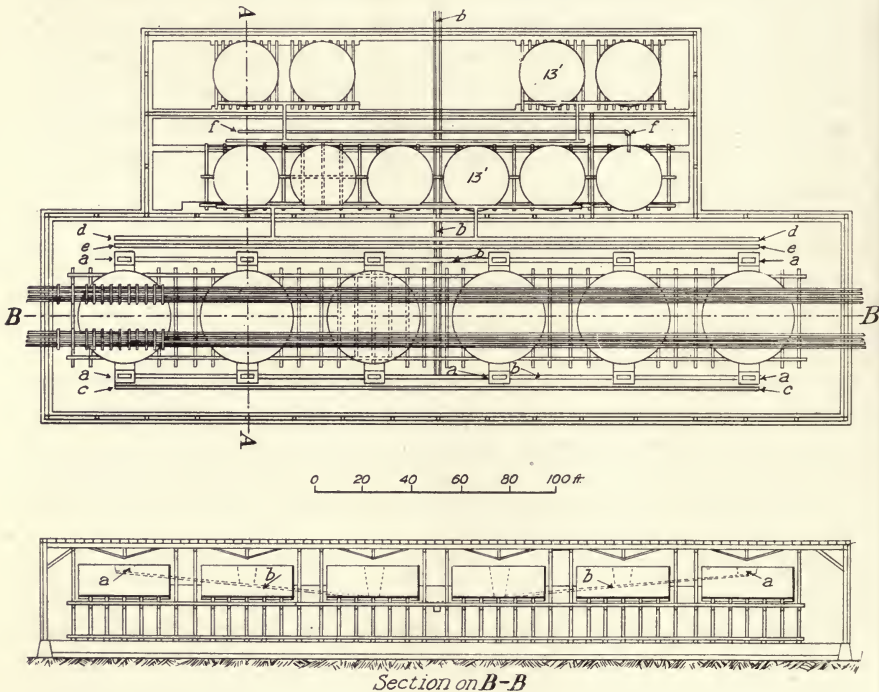

Fig. 114. PLAN AND ELEVATION OF LIXIVIATION PLANT FOR SILVER ORES.

argentiferous blende that has been hand-picked or concentrated from galena, and may still contain lead up to eight per cent.

The hyposulphite process is based upon the fact that silver chloride readily dissolves in dilute solutions of sodium hyposulphite. The chloridizing roasting is unquestionably the most important part of the process, and the chief attention and study is to be given it.

The process consists in crushing the ore, roasting it, and treating the roasted ore in filter-bottom vats, first with water to remove the soluble chlorides and sulphates of the heavy metals (base-metal

leaching), then leaching with a dilute solution of sodium hyposulphite to dissolve the silver chloride. Silver sulphide is precipitated from the filtrate with sodium sulphide, dried, and roasted to remove the sulphur, and the residue is sent to the smelting works, or treated in an English cupelling furnace.

The treatment of the ore to the point where it is stored on the cooling floor, has been described under dry silver-milling, which see.

Fig. 114 and 115 show the plan and elevation of a plant for the treatment of roasted ore by hyposulphite lixiviation. At the high level there are six leaching tanks, each 20 ft. diam. by 6 ft.

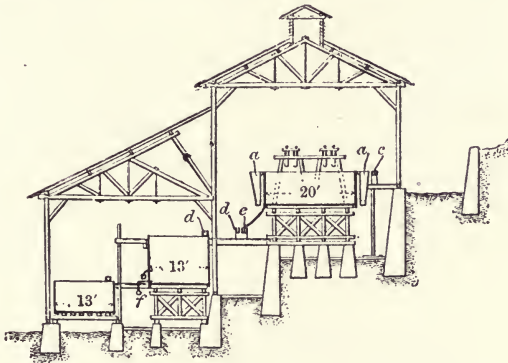

Fig. 115. SECTIONAL ELEVATION OF PLANT FOR THE LIXIVIATION OF SILVER ORES.

deep and each holding 60 tons. These are commanded by a double track over which the ore is brought to them. At the next lower level are the six precipitating tanks 13 ft. diam. by 10 ft. deep, and at a still lower level are four sump-tanks, serving also as storage tanks, whence the barren solution is returned by centrifugal pump to be again used. The tanks rest upon trestles, so as to be accessible for inspection and repair. The precipitate is treated in a building not shown.

Base-metal leaching.—The cooled roasted ore is sprinkled with water from a hose, and piled at the side of the track awaiting to be trammed to the leaching vats. Fig. 116 represents, in plan and sectional elevation, a leaching-vat having a false-bottom of wooden strips covered with cocoa matting and canvas. Into the vat is dumped the ore, which is leveled a foot below the top of the tank.

If the wash-water were admitted above and allowed to leach downward, it would dissolve the silver chloride, carrying it away

in the wash-water. To avoid this, water is admitted below the false-bottom and made to ascend through the charge until the vat is full. The wash-water is then allowed to flow out at the bottom

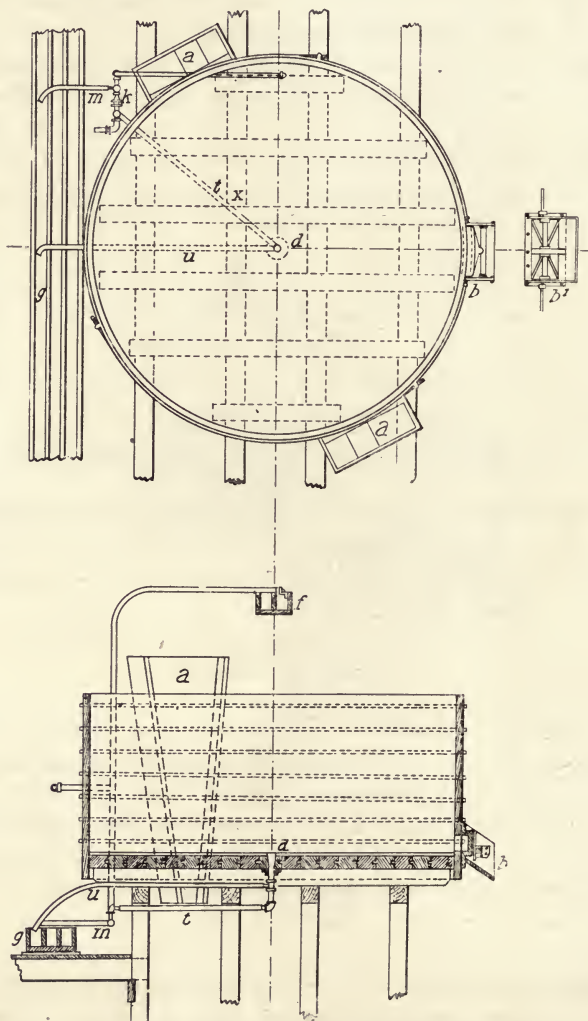

Fig. 116. VAT FOR HYPOSULPHITE LIXIVIATION.

of the vat, and fresh water is admitted on top. By this means concentration of the silver in the solution at the lower part of the vat is avoided, and that in the upper part is soon counteracted by the dilution. The precaution does not prevent the dissolution

of a small amount of silver chloride in the salty water, and the first of the discharge is run to a special precipitation-vat at the end of the row. The flow is through the outlet *d*, Fig. 116, and the hose *u*, opened for the purpose, and thence by launder *g* (marked *d* in the plan Fig. 114) to the vat. Here the silver is precipitated by sodium sulphide.

When the quantity of copper in the ore warrants, the clear solution, decanted from the silver precipitate, is passed through launders containing scrap-iron to recover the copper. In any case, the washing of the ore in the leaching vat continues two or three days, the hose being turned into the next compartment of the launder *g* (*e* of Fig. 114) and the last of the wash-water run to waste. The completion of the washing is so thorough as to entirely remove the soluble base-metal salts.

Silver leaching.—A cold dilute solution of sodium hyposulphite ('hypo solution') is admitted to the leaching vat above the ore. It enters from the main distributing launder *c*, by a short rubber-hose, the end of which can be raised to stop the flow. The leaching proceeds rapidly, the outlet *d* being kept open.

The hypo-solution dissolves silver chloride, reacting as follows:

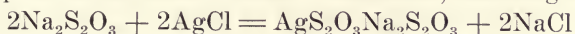

Not only the silver chloride, but also silver, silver oxide, silver arsenate, silver antimonate, and gold pass into solution. Copper chloride dissolves much like silver. Lead sulphate and calcium sulphate dissolve, but the solvent power of the hypo-solution is diminished by the presence of lead sulphate or sodium sulphate, and particularly of caustic alkalis and alkaline earths such as quicklime, presence of the latter being due to the roasting of the limestone in the ore.

The lower part of the ore in the roasting vat, after washing, contains 15 to 20% moisture, causing the first of the hypo-solution to be greatly diluted. To avoid weakening the whole stock of solvent the portion first traversing the ore is rejected. As soon as the effluent, tested with sodium sulphide, shows traces of precipitation, the hose is transferred to launder *g* and the solution admitted to the special precipitation-vat and treated as already described. When samples from the discharge yield distinct precipitate, the liquid is run to one of the regular precipitating vats.

Leaching proceeds until tests show that the silver is extracted. The flow of hypo is then stopped, and a water-wash run on. This removes the hypo-solution, and by changing the hose, the flow can be directed to one of the four sumps, or stock-tanks, at the lowest

level, until the solution becomes weak and does not pay to save. To avoid excessive solvent, and to provide adequate circulation the outlet *d*, Fig. 116, of the tank is connected through *t* with the Koerting injector *k*, which produces a partial vacuum below the filter-bottom, and forces the solution into the launder *g* (*c* in Fig. 114), whence it is admitted again to the charge. The final draining is through the hose *u* to the launder *g*. When lead or copper is contained in the ore it is advisable to use dilute hypo-solution (1.0 to 1.2%) circulating in large volume. The dilute solution acts upon the silver salts in preference to the lead salts (selective affinity) and the former can be extracted without serious dissolution of the latter. The greater part of the solution is extracted during the first 8 to 12 hours of the silver leaching, and is known as the sweet solution, because of the sweet taste of silver chloride dissolved in the hypo-sulphite. The metal precipitated from this solution will be 80% silver; on the other hand, the precipitate from solution flowing from base ore, during the remainder of the period, is poor in silver, hence the advantage of using dilute solutions, and of leaching rapidly. Under these conditions, with ores containing much lead and copper, we may expect to obtain a solution that will yield 1.5 to 2.4 oz. silver per ton when 30-oz. ore has been successfully chloridized.

Precipitation.—A strong solution of sodium sulphide is added to the silver-bearing solution in the precipitation tank and well stirred by hand or mechanically. The quantity of sodium sulphide should be such as to leave a slight excess of silver solution rather than an excess of sodium sulphide. The proportion is determined by testing a sample with a drop of sodium sulphidé.

The silver precipitates as sulphide as indicated in the following reaction:

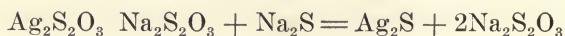

Sodium hyposulphite is regenerated: Gold, copper, zinc, and lead are thrown down.

When the proper time has arrived, the precipitate is allowed to settle, and the supernatant solution, drawn down to 1½ to 2 ft. above the bottom of the precipitating tank, is run to one of the sump or stock-tanks below, making use of the floating hose, see Fig. 76.

The effect of adding the sulphide is to regenerate the hyposulphite, making it again suitable for use. If necessary, it may be further strengthened by the addition of the dry salt. Sodium sulphide solution may be made at the works by dissolving caustic

soda in its own weight of water at 80° C. in a 3-ft. diam. iron kettle, adding gradually powdered sulphur to the solution. The addition of sulphur causes the liquid to increase to two or three times the original bulk, and in the beginning the pot should be only one quarter full. The sulphur, 60% the weight of the caustic soda, dissolves in a few minutes. The sodium sulphide solution resulting is poured into a mold in which it solidifies. For use it is dissolved in water. The sulphur needed varies from 4 to 9 lb. per ton of ore treated, and the sodium hyposulphite 2 to 4 lb. per ton.

Treatment of the precipitate.—The residue in the precipitating tank is discharged through the pipe *f*, Fig. 114 and 115, to a collecting tank in a building not shown. From the collecting tank it is pumped to a filter press, and after pressing, the damp precipitate is put in a reverberatory furnace 16 by 6½ ft. hearth dimensions having a small grate to give a moderate heat. It is heated gradually in the furnace until quite dry, after which the temperature is increased to burn the sulphur.

The dried precipitate is 14 to 35% silver and 15 to 27% copper. Where ore is comparatively free from copper and lead, the silver may rise to 45 or 55% in the precipitate. In the following table we give an analysis of sulphides from the Marsac mill, Park City, Utah.

	Per cent.
Ag (10.124 oz. per ton).....	34.78
Au (11.7 oz. per ton).....	0.04
Cu	21.60
Pb	0.50
Fe	0.75
Sb	0.18
Al ₂ O ₃	0.25
SiO ₂	0.25
S	20.74

The dried and roasted sulphides are generally sold, and go to smelting works where they are smelted directly, being fed into the blast-furnace in sacks, or treated in an English cupelling-furnace as follows:

Thrown upon the molten lead-bath in the hot furnace, a few shovelfuls at a time, the roasted precipitate melts. The silver enters the lead. The base metals, undergoing a scorifying action, enter the litharge. The slag continuously forming flows from the furnace, and being a litharge slag, and containing silver, is sent to the silver-

lead blast-furnace. When all the sulphide has been treated, the lead of the molten bath is cupelled. The silver is left behind and is tapped from the furnace into molds to form bars or ingots.

Cost of treatment.—At Sombrerete the ore contains 9 to 10% lead as galena, blende, chalcopyrite, silicious gangue, and silver sulphide. The ore assays 41.9 oz. silver per ton. It loses by roasting 4.8% of this. The extraction, figured on the raw ore, is 82.5%. The treatment cost is as follows:

Crushing	\$1.36
Roasting (including the use of 6% salt)....	2.68
Labor at the leaching plant.....	0.27
Chemicals	0.30
Superintendence	1.02
Heating, lighting, pumping, and repairs....	0.08

Cost per ton.....	\$5.71

Clemes has given the cost in Mexico, at works treating 40 to 50 tons per day, as being ₧8 to ₧9 in the coast districts, and ₧11 to ₧12 in the mountain districts. In small works the ratio of the cost of superintendence to the total cost is high. The small works are usually directed by the owners.

65. THE RUSSELL PROCESS.

This is a modification of the Patera process, principally by the use of another solution, in addition to the hypo-solution, for the extraction of the silver. By mixing in solution two parts of the hypo-salt with one of copper sulphate we obtain a double salt $2\text{Na}_2\text{S}_2\text{O}_3 \cdot 3\text{Cu}_2\text{O}_3$, called the extra-solution. It has a solvent power nine times as great as that of the ordinary hypo-solution for native silver, silver sulphides, silver arsenides, and silver antimonides. In the case of an imperfectly roasted ore the use of the extra-solution insures the extraction of more silver from the compounds mentioned than could be obtained by the use of ordinary hypo-solution.

The practice at the Marsac mill, Park City, Utah (See Fig. 117), is as follows: The silicious ore, containing 5.3% copper, 0.39% lead, 37.3 oz. silver, and 0.05 oz. gold per ton, is dried and dry-milled, using a 30-mesh screen, and obtaining an output of $2\frac{1}{3}$ tons per stamp in 24 hours. It is then mixed with 8.9% salt and roasted in a chloridizing furnace, then delivered to the point marked 'cooling floor', Fig. 117.

The ore, when cooled and chloridized, is charged to the ore-lixiviation vat 17 ft. diam. by 9 ft. deep, holding 72 tons: It is here treated by a water-wash for 19 hours, using 0.56 ton water per ton ore, the water percolating the charge at the rate of 4 in. per hour. Dissolving the base-metal salts and a part of the silver

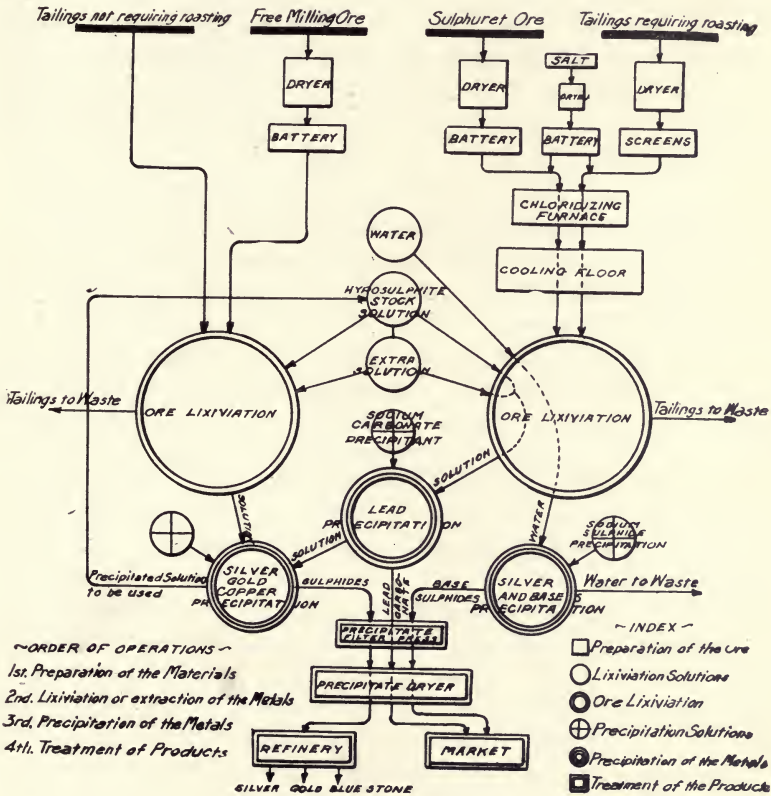

Fig. 117. FLOW-SHEET OF RUSSELL PROCESS.

chloride the percolating wash-water passes to the silver and base-metal precipitation tank. Here, by the addition of sodium sulphide, a precipitate is obtained containing on an average 4.2% lead, 3.9% copper, and 1238 oz. silver per ton. This is separated from the contained water in a Johnson filter-press, removed from the press, dried and shipped to smelting-works.

The ore is next treated with a 1.5% hyposulphite stock-solution by which the greater part of the silver is extracted. The first of the flow goes to the base-metal precipitation tank, but, as soon as

the hypo-solution begins to appear, the solution is diverted to the lead precipitation tank. The silver leaching lasts 81 hours.

Now the extra-solution containing 0.75% bluestone and 1.5% hypo is applied to the ore, and further silver extracted from undecomposed sulphides not attacked by the hypo-solution. This operation takes 27 hours, the filtrate being also run to the lead-precipitation tank. The cycle of leaching takes 130 to 150 hours.

In the lead precipitation tank lead carbonate, which is insoluble in hypo-solution, is precipitated by the addition of 5 lb. sodium carbonate per ton of solution, precipitation occurring in result of the following reaction:



The precipitate contains, on the average, 32% lead and 526 oz. silver per ton. After the settling, the supernatant solution is transferred to the tank marked 'silver-gold-copper-precipitation,' while the wet precipitate is filter-pressed, dried, and sold to be smelted.

The solution in the silver-precipitating tank is now treated as in the Patera process with just enough sodium sulphide to bring down the precipitate of silver sulphide containing 35% silver, 20% copper, and 20% sulphur. The clear solution is pumped back to the hypsulphite stock-solution tank to be again used, while the precipitate is pumped to the filter-press, the solution removed, and the resultant moist precipitate dried and roasted at a low heat to remove sulphur.

Thus the filter-press and dryer treat the base-metal precipitate, the precipitated lead carbonate, and the silver precipitate, one after another. The products are sacked, being sold to smelters, who either smelt them directly or treat them in an English cupelling furnace as described in the Patera process.

The extraction by the Russell process is as follows:

	Per cent.
In base-metal sulphides.....	6.2
In lead carbonates.....	2.6
In silver precipitates.....	75.7
In sweepings of the mill.....	0.5
Total recovery.....	85.0

The Russell process has proved successful in exceptional cases only. At Sombrerete and at Cusihiuriachic, Mexico, it has been displaced by the Patera process, while failures have occurred elsewhere. Compared with the Patera process, the cost of chemicals is greater (92c. against 42c.), the plant is more complicated, and

greater skill is needed to work it successfully. It can be applied to oxidized ores, or to those that have been subjected to an oxidizing roast, and though the yield of silver is greater where the extra solution is used, yet this is offset by the consumption of copper sulphate. In presence of much galena or blende the extra-solution extracts silver no better than the ordinary hypo-solution. In presence of much lime, silver is but slowly extracted and copper sulphate is consumed.

Cost.—The cost by the process, based upon an output of 100 tons daily, is as follows:

Crushing and roasting.....	\$4.62
Labor in leaching.....	0.83
Tools, lighting, pumping, and heating.....	0.12
Chemicals	0.92
Repairs and superintendence.....	0.18
Assaying	0.08
Treatment of products	0.10
	Total
	\$6.85

66. CYANIDATION OF SILVER ORES.

Silver ores carrying gold, and in which the silver occurs as chloride, argentite, or stephanite, have been successfully cyanided. Thus at Chloride Point, Utah, where silver occurs as the chloride, the extraction is 71%; at the Palmarejo mine, Chihuahua, Mexico, the extraction is 54% silver and 96% gold; at El Salvador, 85 to 90% silver and 90 to 92% gold; while at Guanajuato, a silver ore, containing silver sulphide and a little gold, is treated with an extraction of 87% of the total metal of value.

Of the silver minerals, native silver, in particles so large as to be visible, is insoluble in potassium cyanide in any reasonable time. Silver chloride, bromide, and argentite, are readily soluble. Ruby silver, stephanite, and frieslebenite are sparingly soluble in potassium cyanide but readily soluble in mercurous potassium cyanide solution.

Important matters in cyaniding silver ore are the following:

(a) A long time (10 to 25 days) in the case of sand treatment is needed for leaching. For slime treatment 96 hours would suffice for a complete cycle in which time a higher percentage of extraction would be obtained than by a 14-day treatment of the

corresponding sand. The silver compounds are more difficultly soluble than gold, and a larger amount must be dissolved.

(b) Thorough oxygenation is necessary, not only because of the large amount of silver present, but because silver compounds need at least initial oxidation to become properly soluble in cyanide solution. Hence an advantage is secured by the double treatment of sand, as described under the 'second method' for the treatment of gold ore. Also during leaching, if the solution be allowed to sink several inches below the top of the charge, before another wash-solution is run on, air is drawn and penetrates the ore, and the solution following forces the air downward through the ore. In the treatment of the slime the pulp may receive through aeration by agitating with air.

(c) Stronger solution is used than for the treatment of gold ore. Thus the first or strong solution may be 0.7%, the weak one 0.25%, while for gold ore, a 0.5% solution would be called strong and 0.05% weak.

(d) The consumption of potassium cyanide is higher than in the treatment of gold ores. It varies from 2.5 to 4 lb. per ton as compared with 0.4 to 0.8 lb. consumed in the treatment of gold ores.

(e) The precipitation of silver from cyanide solution by zinc shaving presents no difficulties, and is practically complete. Despite the fact that a relatively great amount of silver has to be precipitated, as compared with gold, no more zinc is consumed.

The separation and leaching of the sand should be discontinued in many cases, since leaching by cyanide solution only slowly dissolves the fine mineral particles that are enveloped in the quartz grains, and the time that economically can be allowed for extraction is inadequate. When the ore is tough and hard and the added expense of fine grinding offsets the additional extraction, the above practice would not apply. In most ores a part of the silver sulphide is so finely disseminated in the gangue that it becomes necessary to grind the ore to pass a 150-mesh screen before the sulphides are liberated sufficiently from the enclosing quartz to permit a satisfactory extraction of the silver by cyanidation.

While mechanical agitation of slime in tanks provided with stirring-arms is common, agitation can be more economically and effectively executed by the use of Brown's agitating-tank, Fig 118. This is provided with an air-lift consisting of a 12-in. pipe extending nearly to the bottom of a tall conical-bottom tank 13 ft. diam. by 55 ft. high. A central pipe *c* supplies air under pressure. The air

bubbling through the pulp causes a flow upward, and creates a circulation. By this method a large proportion of fine sand can be suspended in the slime pulp as would not be possible by the

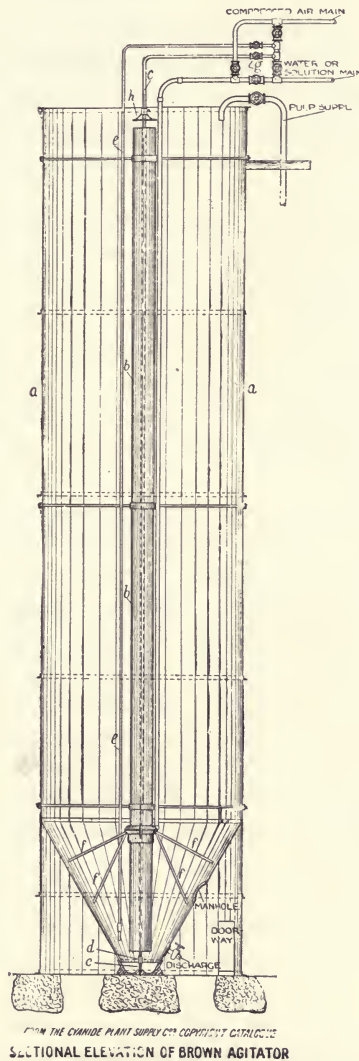

Fig. 118. SECTIONAL ELEVATION OF BROWN AGITATOR.

usual stirring and pumping method of agitation. Upon the dissolution of the gold, the slime is filter-pressed.

The tendency in advanced practice is to classify and finely grind the sand to pass a 150-mesh screen, to add this to the slime, and

to agitate and filter-press the united product. The fine sand thus present with the slime makes it more easily filtered.

67. CYANIDATION OF SILVER ORES AT GUANAJUATO.

The ore consists of pyrite associated with a quartz gangue with, disseminated, the silver sulphides argentite, stephanite, and pyrargyrite. It carries 14 oz. silver and 0.08 oz. gold per ton. The treatment is that described in outline in the 'second method' of cyaniding gold ores, except that here the ore is crushed in barren cyanide solution.

The ore is fed from storage bins to Blake breakers and is crushed to 2-in. size. It is elevated by a bucket elevator to the sorting-room, and passed over a grizzly to separate the fine while the lump-ore falls upon a sorting belt. From 10,000 tons of ore, the monthly output, ore sorters pick out the waste, leaving 8000 tons which is hauled in cars drawn by industrial locomotives to the storage-bins of the stamp-mill, the total cost being 8c. per ton. Thus the grade of the ore is increased at the start and the quantity for treatment diminished.

As the ore (260 tons daily) is dumped into the storage-bins, 1% quicklime is added to neutralize the free sulphuric acid in the ore and furnish protective alkalinity to the cyanide solution. The ore is fed automatically to the stamps, where 7.2 tons of barren solution (0.025% cyanide) per ton of ore is used. Thus the silver begins to dissolve even while the ore is being crushed. From the battery the ore passes through a 50-mesh screen at the rate of 3.3 tons per stamp daily. The smaller tonnage compared with the output elsewhere is due to the fine screen used. No portion of this pulp is subsequently re-ground and about 60% will pass 200-mesh. The rich parts of the ore are the more friable, and consequently enter the finer sizes.

The pulp from each five-stamp mortar flows through spitzkasten each having two compartments 22 in. square by 22 in. deep. The overflow of slime goes to the slime-tanks, while the spigot-discharge, or underflow, unites and passes to the Wilfley concentrating table. The concentrate from the table goes to storage-tanks in the concentrate room, the slime-overflow from the last five feet of the Wilfley table goes to the slime-tanks, and the remainder of the tailing to a Frue vanner for re-treatment. The vanner concentrate goes to the concentrate-room and is mixed with the Wilfley concentrate. The concentrate amounts to 2.5% ore and contains 50% total value. It carries 40% Fe and 6% SiO₂, and is sent to the smelter. Mean-

while the vanner tailing, containing all the sand, flows to classifying cones $3\frac{1}{2}$ ft. diam. provided with hydraulic water. The overflow goes to the slime-tanks.

The sandy spigot-discharge, containing slime, passes by a launder to the sand-elevator and discharges into the small cone-separators 18 in. diam. provided with hydraulic water. Here the overflow removes further slime which goes to the slime-vats. The underflow, or spigot-discharge, of the cone-separator is discharged into the collecting vat near the side. Here it accumulates, sloping away gradually to the opposite side of the tank. A grating, such as was described under the 'second method,' and shown in Fig. 86, permits the escape of slime-bearing water. The grating is covered as high as the level of the top of the sand with a canvas roll-curtain to retain the sand. Should the sand still contain slime, a boy with a hose can wash the slime from the surface of the depositing sand through the grating to the slime-tanks. The sand-vats, seven in number, have filter bottoms and bottom-discharge valves or doors. They are 26 ft. diam. by 5 ft. deep, and hold 90 tons of classified sand.

Preliminary treatment of sand.—The collected sand receives the first treatment in the vat in which it settles, thus making the vat one of preliminary treatment. To fill the vat requires 15 hours, and to drain 15 hours more. The sand retains 18% moisture. Upon the charge is now run 20 tons of solution containing 0.3% KCN to which has been added 20 grams of lead acetate per ton. This is allowed to soak 12 hours. While adding the solution, a basket, containing 50 lb. dry cyanide salt, is placed under the stream and the salt slowly dissolved and carried into the charge. The addition is sufficient to re-enforce the solution to the strength of 0.3% KCN in spite of the dilution by the moisture in the charge. Percolation and drainage now follow. Drainage causes aeration of the charge. The preliminary treatment is completed by a second saturation, percolation and drainage of the same tonnage and strength of solution of the first. The recovery of 35 to 40% of the original value of the ore is the result.

Second treatment of sand.—The first treatment being complete, four discharging-doors in the bottom of the tank are opened, and the sand containing 14% moisture is shoveled into double side-dumping tram-cars running on tracks below the tanks, and above the second treatment or sand-tanks. There are 15 sand-tanks, each 26 ft. diam. by 6 ft. deep, being made more capacious to provide for the sand which does not pack in them as in the collecting tanks.

While a tank is being charged, 1000 lb. quicklime is distributed uniformly through the charge. The sand is next saturated with 30 tons of strong solution to which is added 50 lb. dry cyanide, and allowed to remain in the tank one day. The outlet valve is opened, and the solution is allowed to drain through the charge. The sand is saturated a second time with the regular strong working-solution of the same strength and tonnage as before. The solution valve is opened again and the admission of strong solution, and the percolation simultaneously proceed $6\frac{1}{2}$ days. The sand is next washed with weak solution (0.15% KCN) two days, and then with water 18 hours. The two bottom doors of the tank are opened and the sand sluiced out and carried by launder to the dump. The total time of the double treatment is 16 days, during which 9 lb. lead acetate is added for a 90-ton charge. The progress of the double treatment of a charge of sand is shown in Fig. 119.

Slime treatment.—There are 24 masonry slime-tanks, each 8 by 9 ft., in two rows, beneath the concentration-mill floor. The stream of slime, separated from the pulp as already described, flows through one row of the tanks until filled. The stream is then diverted to the other row. The slime in the first row is permitted to settle quietly, and the clear supernatant water is decanted into sump-tanks and again used at the mill. The residual slime in the tank contains three parts water to one of dry slime, and amounts to one-half the original ore.

From the settling tanks the thickened slime goes to 14 slime-treatment tanks, each 30 ft. diam. by 10 ft. deep, provided with stirring arms for mechanical agitation. The charge weighs 140 tons and contains 35 tons of slime, dry weight. As the stream of slime enters the tank it flows upon a basket containing potassium cyanide to strengthen the solution to 0.1% KCN. Then 200 lb. quicklime and 18 lb. lead acetate are added. The lime corrects acidity, gives protective alkalinity, and assists settling; the lead acetate decomposes alkaline sulphides that would precipitate silver from the cyanide solution. The charge fills the tank to a depth of 8 ft., and the remaining 2 ft. is filled with 0.1% KCN solution from the stock-tanks. The solution dilutes the slime five to one, a proportion found necessary for the successful treatment of the charge.

Agitation now proceeds uninterruptedly 24 hours, after which the charge is allowed to settle six hours. By this time three feet of the clear solution can be decanted to the adjacent 'clarifying' or clear-solution tanks. The slime-treatment tank is again filled with 0.1% KCN solution, adding the same charge of lime and lead acetate as

before, and agitation is resumed and continued half an hour. The pulp is allowed to settle; the clear solution to the depth of 18 in. is decanted, and the tank filled with weak solution after the requisite addition of lime. Six washes like this follow, making eight in all, followed then by two water-washes. The settled slime is now pumped to one or two settling tanks set at a high level, where it mixes with weak solution previously pumped into the tank to the depth of 6 ft. The mixture is allowed to settle as long a time as the tank can be spared for the purpose. The clear solution is decanted into the clarifying tanks, each 6 ft. diam. by 12 ft. high, with the solution decanted from the slime-treatment tanks. The pulp remain-

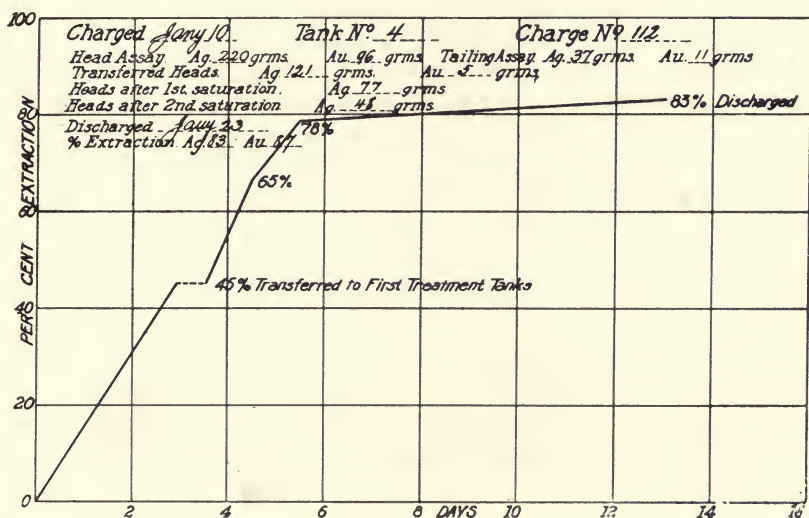

Fig. 119. SAND-TREATMENT CHART AND RECORD.

ing in the high-level settling-tank is then run to waste. The various decantations entering the first clarifying tank, flow across it to the second, passing through three curtain-screens of cocoa-matting covered with burlap which form partitions through which the solution is strained.

Treatment of the silver and gold-bearing solution.—The strong solution from the leaching tanks is received in the strong gold-solution tanks. The weak solution and water-wash of these tanks, as well as the solution from the clarifying tanks, goes to the weak gold-solution tank, and after passing through the zinc boxes to the strong-solution and weak-solution sump-tanks respectively. From the sumps the barren solution is pumped to the stock-tanks to be

re-enforced to working strength by the addition of dry cyanide and again used. Some of the weaker solution (0.025% KCN) is pumped to the reservoir storage-tanks for use in the batteries. The total weight of solution used is 15.5 tons per ton of ore, or for the daily tonnage of 260 tons, 30 to 40 tons of solution passes through the zinc-boxes.

The clean-up.—The zinc-boxes are cleaned up three times a month as described under the first method of cyaniding, the precipitate being run to a clean-up sump-tank, and without acid treatment, pumped through a filter-press. The cake of precipitate from the press contains 30% moisture, 52% silver, and 3% gold. The 15% remaining consists of zinc, lead, copper, sulphur, and silver. The precipitate is mixed with fluxes in a large tray, using 100 parts precipitate, 30 of borax, and 18 soda. The mixture is transferred to shallow sheet-iron trays, dried by steam, then charged into No. 300 graphite crucibles and melted. The molten metal is cast into bars weighing 1000 oz. each, 860 fine in silver and 5 fine in gold, the remaining 135 parts being zinc and lead. The total extraction is 87% of the contained gold and silver.

It will be noticed that, whatever the grade of the ore, the assay value of the tailing remains uniform (See Fig. 94). The recovery not only applies to ore, but to the concentrate, which yields 98% when treated by cyanidation. In the practice at the Guanajuato plant the low extraction is due to decantation of the slime and could be increased by filter-pressing. An increase also would result if the sand were more finely ground.

The itemized cost per ton of ore is as follows:

Cyaniding: Labor	\$0.205	
Supplies, including cyanide, etc...	1.030	
Electric power	0.130	
Assaying	0.060	
General office expense	0.070	
Plant expense, management, etc...	0.120	
		1.615
Crushing and sorting ore.....		0.082
Milling		0.550
		\$2.247

PART V. IRON

PART V. IRON.

68. IRON ORES.

The oxides of iron occur with earthy materials and never in a pure state. Only those are called iron ores that contain sufficient iron to make the recovery of the metal profitable. Iron ore is also used as a flux in the smelting of copper and lead ores, in which case the iron enters the slag and is wasted. The three kinds of iron ore used in making pig iron are: the hematites, the magnetites, and the carbonates.

Hematite (Fe_2O_3) is the best known of the iron ores. It contains, when pure, 70% iron. When the proportion of contained water is low it is called red or brown hematite, while the hydrous varieties are called soft hematites or limonites, although the name limonite is more properly applied to bog-iron ore, containing 20% water. The rich varieties (Lake Superior ores) contain 58 to 64% iron, while the limonites run as low as 50%. By roasting the ore the water can be mostly driven off and the ore improved in grade and made better for smelting. Oolite is a variety that exists in the form of grains or nodules and contains silica or lime. When silicious, as in places in Alabama, the ore is well-nigh worthless, but when limey, as in the Minette district of Germany, the ore is self-fluxing, that is, the lime will flux the silica that the ore contains. It then becomes unnecessary to add flux: The ore of these districts runs as low as 30 to 35% iron, yet it can be smelted at a profit because of the self-fluxing property. Red hematite iron ore is the most desirable. Most of the Lake Superior deposits are of this variety, and they are there divided into two classes: the hard or lumpy ore of the Michigan and Wisconsin ranges, and the soft ores of those ranges, but especially of the Mesabi range in Minnesota. Among the ores of the United States we should also mention the Alabama beds, and those of Colorado and Wyoming in the West.

Magnetite (Fe_3O_4) as a pure mineral contains 72.4% iron. It is so named because it is strongly attracted by the magnet, whereas other varieties of iron ore are but little affected. Magnetite occurs in large deposits in Sweden, and in various parts of the United

States. While some of the beds are rich, many contain no more than 40% iron and carry so much silica that the fluxing and smelting is not profitable. Much work has been done in the concentration of these ores, both in Sweden and the United States. In New Jersey extensive beds occur that have been utilized by Edison for the production of a high-grade ore on a commercial scale. He has mined the deposit, crushed and concentrated it, and made it into briquettes that contain as little as 3.3% silica and 0.04% phosphorus, and as high as 67% iron. The enterprise, however, could not continue at a profit in competition with foreign ores from Cuba and Spain. The extensive plant, so ingeniously devised and constructed by him, is not now in operation. Some of the New York beds near Lake Champlain have been considered valueless on account of the presence of titanium, it having been asserted that this element produces an infusible sticky slag. This, however, has been proved to be unfounded, and it should not prevent their use as a source of iron. It is to be noted that the famous Iron Mountain, Missouri, is a deposit containing 31% iron and 6% titanium oxide, but the deposit is not now worked. In Pennsylvania the Cornwall beds are the most important, and yield a pig-iron carrying not more than 0.04% phosphorus. The ore runs 2.5% sulphur, and about half of this is removed by kiln-roasting before smelting. It contains also copper, which will be found in the pig to the extent of 0.5 to 0.75%. This does not matter in the finished product, but, if the pig-iron is made into steel, the copper causes 'hot-shortness' or brittleness when hot, thus causing imperfections when rolled into shapes. The average of ore mined is 40 to 42% iron and 20% silica.

Carbonate ore, siderite (FeCO_3), as a pure mineral contains 48.3% iron. The varieties are spathic, black band, clay-band, or clay iron-stone. It is often roasted to expel the moisture and carbon dioxide before going to the blast-furnaces. In England it forms the well known clay iron-stone of the Cleveland district, but in the United States, though widely distributed, it is too low in grade to be used in competition with the abundant rich ores.

69. SMELTING FOR PIG-IRON.

Outline of the process.—The operation is conducted in a furnace, often 100 ft. high, filled with a mixture of coke, iron ore, and limestone. Superheated air is blown in at the bottom. The coke is burned to maintain a high temperature in the furnace and to reduce the iron in the ore to the metallic form as pig-iron. The pig-iron collects at the hearth or bottom of the furnace, and is removed from

time to time. The gangue, or silicious part of the ore, is fluxed with limestone, and produces a worthless slag, or cinder, which is also removed (tapped) as it accumulates in the furnace.

70. BLAST-FURNACE PLANT.

Fig. 120 is a view of an iron blast-furnace plant for the manufacture of pig-iron from iron ores. In the foreground is a cylindrical



Fig. 120. IRON BLAST-FURNACE.

furnace-stack 100 ft. high, immediately in front of which is the forked 'down-comer' (See 39, Fig. 122), a large pipe that conveys the smoke from the stack near the top downward to the flue-system:

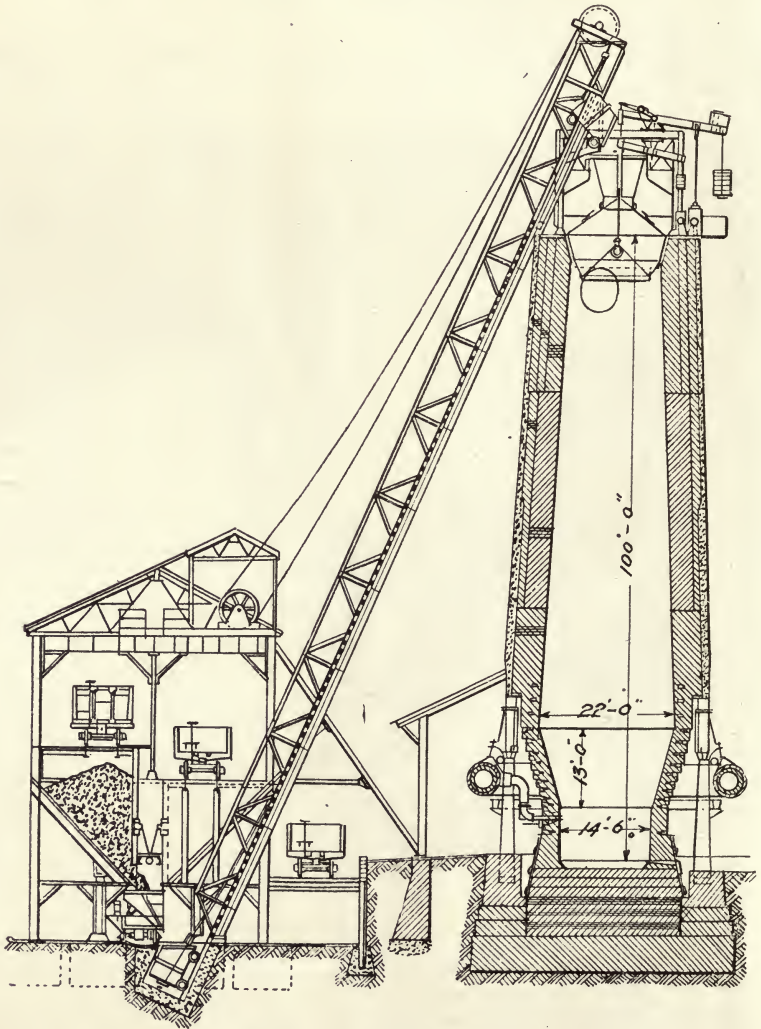

Fig. 121. IRON BLAST-FURNACE WITH AUTOMATIC CHARGING.

that carries it away. In front of the down-comer we see the inclined hoist for the 'stock' or the materials that are put into the furnace. At the middle of the illustration are the four cylindrical 'stoves', as high as the furnace, used for pre-heating the air blown into the furn-

ace, while the highest stack behind them draws away the gas from the stoves. In front of the four stoves is the blast-main, a pipe 5 ft. diam., by which the air is conducted to the furnace. At the left of the stoves is the building (not shown), that contains the vertical blowing engines by which air, under 15-lb. pressure, is delivered through the stoves to the blast-furnaces. Fig. 125 represents a vertical blowing engine.

The general arrangement about the furnace is understood from the sectional elevation Fig. 121. The blast-furnace 100 ft. high is at the right. It is served by an inclined hoist, one skip of which is in position in the pit ready for loading, the other in discharging position at the top. Within the stock-house, at the left, are three standard-gauge tracks on three levels. The upper one at the left is for the hopper-cars that deliver iron ore and fluxes to sloping-bottom bins beneath, shown in section.

The second one leads to similar bins (not shown in section), and the third to the floor on the ground-level. On this level is a charge-car, electrically driven, with a weighing attachment that can be brought to any bin to receive a weighed amount of stock. The load is then transferred to and discharged into the skip. In case of accident to the charge-car, or any trouble at bins, the furnace can be supplied by the use of hand-barrows or buggies, taking the stock from the piles that have been made beneath the third track. Hoisting is done by a hoisting engine set well out of the way at the top of the stock-house. Just beyond and at the right of the furnace is the cast-house where the molten iron is molded into pigs when a cast is made.

71. IRON BLAST-FURNACE.

Fig. 122 is a furnace, shown in part section, and part elevation. It is circular in cross-section.

Beginning at the bottom we have a heavy foundation of concrete and fire-brick upon which rests the hearth 15 and columns 4 which support the upper brick work that constitutes the shaft of the furnace. The hearth or crucible ($14\frac{1}{2}$ ft. diam. by $9\frac{1}{2}$ ft. deep), that contains the molten iron and slag, extends from the foundation to a height slightly above the tuyeres 22. The bottom and walls are of fire-brick, and near the bottom is the iron-tap 27 through which the molten pig-iron is withdrawn when a quantity has accumulated. At 24 is the cinder-notch or tap by which the slag or cinder is drawn off. The crucible is surrounded by a hearth-jacket of steel plates, cooled on the outside by sprays of water that play against

it, cooling and protecting it and the brick-work lining from the corrosive action of the molten slag inside. Air, under a pressure

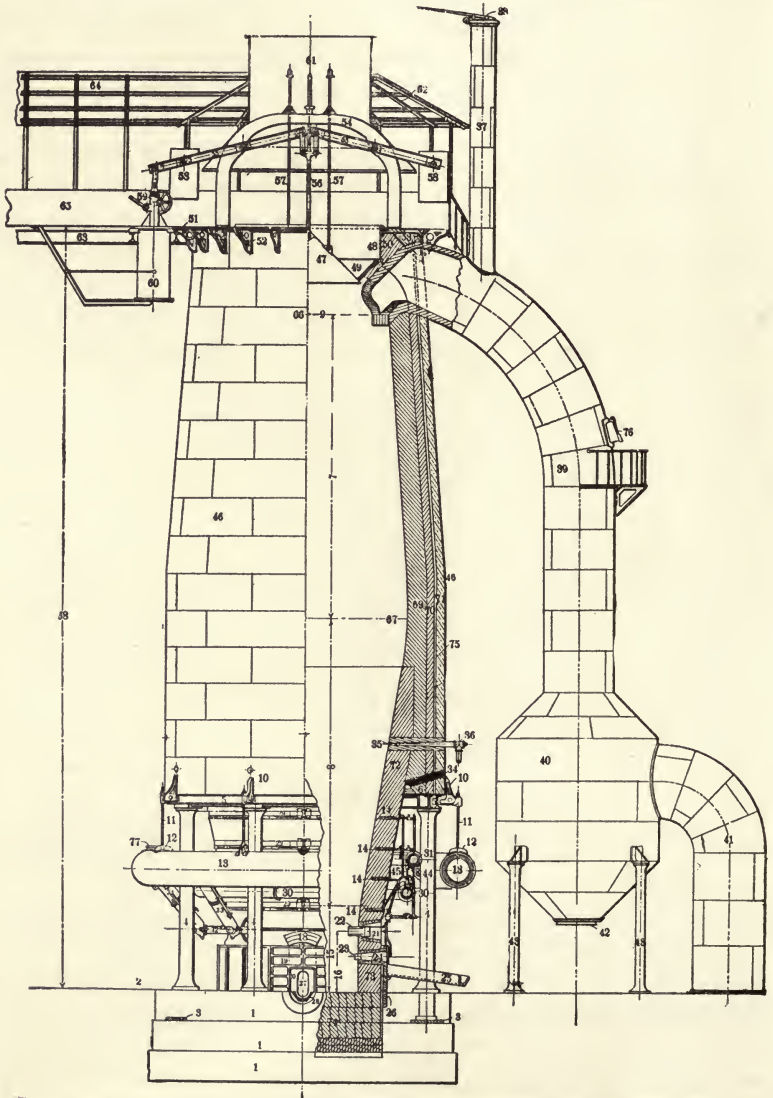

Fig. 122. IRON BLAST-FURNACE, DETAILED SECTION.

of 5 to 14 lb. to the square inch enters through the tuyeres 21, which have projecting nozzles 22. Care is taken to withdraw the slag before it reaches the level of the tuyeres, for it would enter the

openings and close them. Of these tuyeres there are six. The air is supplied through the tuyere-stocks 33 from the bustle-pipe 13, which encircles the furnace, and connects with the blast-main supplying air at the temperature of a red heat from the stoves. The bustle-pipe, tuyere, and tuyere-stock are shown in the section Fig. 121. The bosh, or that part of the furnace that widens from 14 ft. 6 in. at the hearth to 22 ft. in a vertical distance of 13 ft. is also shown. It is in the region of the bosh that the formation of the slag occurs, and the brick-work of the bosh is subject to a slagging and scouring action that tends to attack and destroy it. To prevent this, hollow water-cooled bosh-plates 14 are laid in the brick-work of the bosh, making rings around the furnace at nearly every two feet vertically. The slag cuts into the brick-work nearly as far as the inner ends of these plates, but the circulation of water within them protects the adjacent brick-work from deeper corrosive action.

The shaft, or main brick-work structure of the furnace, is carried by the cast-iron mantel 5 resting upon the columns 4. It extends from the top of the bosh to the throat at 9. The upper part of the furnace is closed by a bell 47 (Fig. 121 shows a double bell), and the gas escapes at the side through the down-comer 39. The in-wall 69 is of fire-brick, while the main portion is of common brick and is sheathed with a shell 46 of steel plates. When in operation the furnace is kept full to a level just below the outlet to the down-comer. This level is known as the stock-line, and the furnace at this point is 15 ft. diam. As the stock smelts and sinks, charges are introduced and the stock-line is maintained at this level.

Ordinarily the top of the furnace is kept closed by the conical bell 47 which is suspended from the ends of the counterweighted beams 55. The bell closes the bottom of a circular hopper 48, into which the charge in this particular furnace is supplied by buggies brought up by elevator to the upper or charge-floor of the furnace or 'tunnel-head,' as it is called. To drop a charge into the furnace, the outer end of the lever is raised by the piston-rod and piston of the air-cylinder 60. The bell thus lowered permits the charge to slide into the furnace, after which it is immediately raised to close the opening and stop the outward rush of smoke and gas that mainly escape through the hood 61. The gas, containing dust from the charge, passes off by the down-comer 39 to the dust-catcher 40 (where a part of the dust settles), and by the goose-neck pipe 41 to an underground flue that leads to the stoves and boilers where the gas is burned. Rising from the down-comer is the bleeder 37,

that is used when it is desired to relieve the top pressure of the gas rising from the charge. It is occasionally used. At many furnaces the stock is raised in hand-barrows or charge-buggies to the furnace-top or tunnel-head 51 by means of a platform hoist. In Fig. 120 is seen at the extreme right, the frame of the hoist.

In Fig. 121 is shown the more recent method of charging with the inclined hoist. A double bell is used to prevent the escape of the gas. The charge is dropped from the hoist into the upper hopper, where it is retained until the lower hopper is empty. The smaller upper bell is then lowered and the charge slides from the upper into the lower hopper, while the upper bell is closed. The hopper is then ready to take another charge. The charge in the lower hopper, when needed is dropped into the furnace by lowering the lower bell. It slides outwardly to the walls, forming a ring or ridge, the stock in the middle being a little lower than at the sides. Some coarse lumps roll toward the middle, so that part of the charge is more open than at the walls. Just beyond and below the lower bell is noticed the oval outlet to the down-comer. The stock-line must be kept below this.

The skips of the hoist run in balance and are charged as follows: The charge-car on the ground level is run to the chute of an iron-ore bin to receive the required weight of ore. It is moved to the limestone-bin beyond to get the needed quantity of limestone, and then to the skip standing below in the charge-pit where it is discharged. The skip is next hoisted and dumped, while the empty one is in position to take the load of coke. After elevating the fuel, a charge of ore and flux next goes. These charges alternate in the furnace and form layer upon layer.

The dimensions of a blast-furnace are limited. The considerations are as follows: The hearth should be not more than 15 ft. diam. lest the blast fail to properly penetrate to the center and maintain intense combustion there. The slope or angle of the bosh-wall must be such as to give proper support to the charge, which rests upon it, and yet allow the solid coke to slip down. The height is limited to the height of the smelting zone. These conditions limit the diameter of the bosh to 22 ft. From the top of the bosh the stack-wall must decrease in diameter to the throat to give room for the descending charge to swell by reactions that occur in the downward progress. This leaves, at the throat, a diameter suitable for the proper distribution of charge. Furnaces have been built higher than 100 ft., but such height has been found to be excessive,

especially for fine ores; and the best practice calls for 90 ft. or less.

72. THE STOVES.

The efficient operation of an iron blast-furnace requires that the air entering at the tuyeres be heated, generally to the temperature of a red heat (500 to 750°C). To do this the furnace is equipped with three or four (as in Fig. 120) regenerative fire-

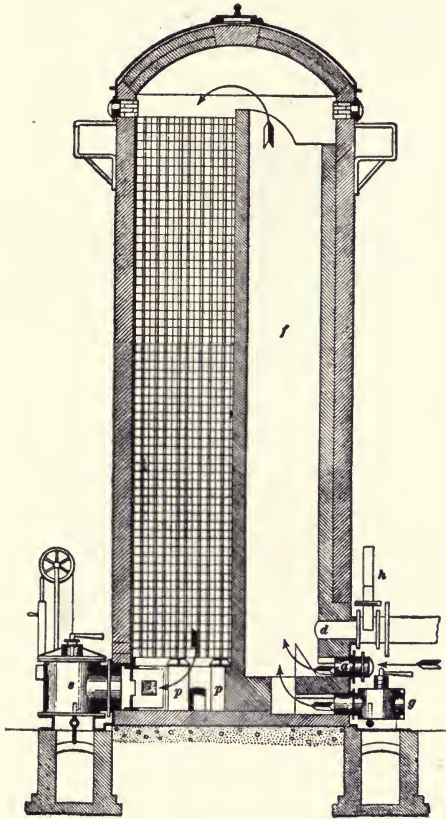

Fig. 123. COWPER HOT-BLAST STOVE (ELEVATION).

brick stoves 80 ft. high and 14 ft. diam. The Cowper stove (of Fig. 123 and 124), for example, consists of a tight shell, like a boiler shell of steel plates, lined with fire-brick, and containing a checkerwork of bricks of special shape laid in open order so as to have numerous openings or passages from the top to the bottom of the stove. The gas from the furnace, containing 24% CO, which in

burning supplies the heat, flowing along the underground flue from the goose-neck before mentioned, enters the stove at *g*, while air is admitted at *a*, the two gases mingling and burning in the vertical circular flue *f*, and heating the checker-work in their passage to the valve *s* as shown by the arrows. The gas thence passes by an underground flue to a tall stack, 200 ft. high, shown behind the stoves in Fig. 120. Gas having burned in this way a half hour, the stove becomes heated. The valves *g*, *a*, and *s* are closed, and the cold-air valve at *c* near the bottom of the stove is opened, admitting air under pressure from the blowing-engine, the hot-air valve *h*,

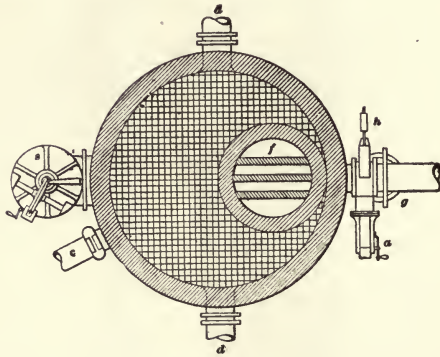

Fig. 124. COWPER HOT-BLAST STOVE (PLAN).

at the bottom of the flue *f*, being at the same time opened. The air rises through the hot checker-work, descends the flue *f* and passes out at *d* to the brick-lined hot-blast main, and to the furnace.

Meanwhile the gas has been turned into the other stoves, and is heating them in the same way. After the blast has been received in the first stove a half hour it is turned into the next heated stove, and so on. The extensive surface of the checker-work serves to absorb a large amount of heat from the burning gas, and to impart the heat subsequently to the blast-air. It will be noticed that the air enters at the coldest and leaves at the hottest part of the stove. It flows in a direction opposite to that which the burning gas does, thus insuring the maximum rise in temperature. In the course of half an hour, the hot air, leaving the stove, falls at least 100°C. in temperature.

Not all the gas from the furnace is needed for heating the stoves, and a portion is burned under the boilers of the plant for making steam for power. The amount of steam thus available is sufficient to run the blowing-engines, hoisting-mechanism, and

all machinery belonging to the furnace. At some plants the surplus gas, after the stoves have been supplied, has been cleaned from dust and used in gas-engines. Power can be gained in this way and is more available for the rolling mill or other purposes.

Formerly the air was heated in iron-pipe stoves, the air circulating through a nest of pipes inclosed in a furnace or brick heating-chamber. These are no longer used, but have been supplanted by the regenerative stove already described.

73. BLOWING ENGINES.

Fig. 125 gives a view of a vertical blowing-engine, having an air-cylinder at the top 7 ft. in diameter and of a 5-ft. stroke. The cylinder displaces 385 cu. ft. air per revolution, or 15,400 cu. ft. per minute, at 15-lb. pressure. The air-admission and discharge valves are arranged to operate positively, and to open and close exactly at the right moment. Enough of these engines are installed to supply the amount of air required by the furnace.

74. OPERATION OF THE FURNACE.

The ore is dumped into the furnace with 45 to 60% of the weight of coke, and the limestone needed to form the predetermined slag. The furnace should be at least 65 ft. high, and is now built 80 to 100 ft. high. It is kept full of stock, and the combustion of the coke is supported by the air introduced at high pressure at the tuyeres. As smelting progresses, the coke burns, the slag and iron produced from the charge is withdrawn, and the surface or stock-line sinks. Thus the removal of molten products below and the addition of fresh stock above, causes the greatest production of heat next the tuyeres, where the coke largely burns, the temperature decreasing toward the stock-line. The actual melting zone, or zone of fusion, extends upward through the bosh-region. The most intense combustion occurs within 4 ft. of the tuyeres, where an excess of air, driven in under high pressure, burns the coke to carbon dioxide. In the reaction, the CO_2 may be said to dissolve the carbon, it being as follows:

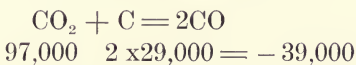

The reaction being endothermic, lessens the temperature in this second region. The temperature is so high, however, that the glowing coke reduces to iron any iron oxide that descends as far down in the furnace as this region. The rising gas consists of CO

and N. The carbon monoxide, in the ascent, reduces the iron oxide to iron. On reaching the lower part of the furnace the iron, with carbon taken from the CO, forms pig-iron. The iron takes up silica, phosphorus, and sulphur from the earthy constituents of the charge. The carbon amounts to 3 or 4%, and the other impurities to 2%, the weight of the product. It is the 5% of the metalloids present in the pig that makes it fusible.

We have, therefore, in the blast-furnace beginning from above, three zones:

(1) The **zone of preparation**, where CO_2 is driven from the limestone and moisture from the charge.

(2) The **zone of reduction**, where the CO of the rising gas reduces the iron ore, first to the ferrous form, then to iron, and where the iron in a spongy or open form absorbs carbon from the reducing gas.

(3) The **zone of fusion**, where the temperature of the furnace is high and the slag is formed, the iron at the same time absorbing silicon, phosphorus, and sulphur.

In the upper zone of the furnace, the carbon dioxide of the limestone is expelled, leaving quicklime (CaO) ready for fluxing the gangue or waste matter of the charge. The reaction is endothermic, lessening the heat of the escaping gases. The quantity of limestone needed to form a suitable slag is calculated in advance.

The gas varies in composition, but commonly contains 61% nitrogen, from 10 to 17% CO_2 , and 22 to 27% CO. The carbon monoxide is the combustible constituent of gas that produces the heat when the gas is burned in the stoves and boilers.

In the foregoing description it has been assumed that coke is the fuel employed as is true in most cases. Anthracite coal has been used when cheap enough to compete with coke, but even then a more satisfactory result is obtained when coke forms part of the charge. Furnaces in which a part of the fuel is anthracite, are called anthracite furnaces, but the name is somewhat misleading. Other furnaces use charcoal exclusively. Charcoal is supposed to give an iron of great toughness that is particularly valuable for cast-iron car-wheels, and other castings requiring toughness. Its superiority over other kinds having the same constitution has been widely disputed, but there is testimony in favor of charcoal-iron.

Thirty years ago, blast-furnace practice was regulated by rule-of-thumb methods. They were "born of a bigoted belief, on the part of ignorant furnace-men, that particular ores and fuel could

be worked in a furnace only on special lines, and that it was impious to drive a furnace faster than a certain rate established by time-worn tradition." In 1879, certain experiments made at the Edgar Thompson Steel Works, Pittsburg, Pa., showed that it was possible to increase the output of a furnace enormously by increasing the air-supply. It was also found that the amount of air, not the pressure, determined the rapidity. Under the new system it

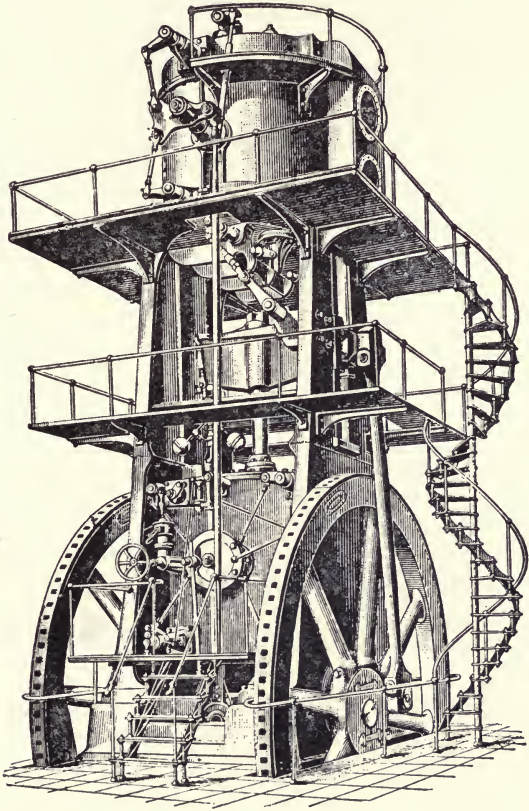

Fig. 125. BLOWING ENGINE.

was thought necessary to make a steep-angle bosh (80 degrees) resembling that in Fig. 122 more than that in Fig. 121. With the more rapid driving, reduction decreased, and the slag contained more iron. To secure the reduction, the fuel had to be kept high, using one ton of coke per ton of pig-iron produced, and where coke was expensive this was a serious matter. E. C. Potter at the Illinois Steel Works, South Chicago, showed that by reducing the

bosh-angle to 75% and using somewhat less blast, it was possible to cut the coke consumption from 2240 lb. to 1800, or even 1750, per ton of pig produced. Furnaces with large hearths were then built, which also increased capacity.

Blowing-in.—The furnace is first dried several days by a wood fire in the crucible. The lower part, halfway up the bosh, is filled with cord-wood. Upon this is placed a heavy bed of coke with limestone to flux the coke-ash, followed by successive layers of the normal charge of coke, with gradually increasing amounts of ore and limestone, and decreasing quantities of slag, until the normal charge of ore and flux is reached. The wood is ignited at the tuyeres, and a weak blast of air supplied. The pressure is gradually increased during 24 hours, and the furnace, becoming entirely filled during this time, the regular pressure is reached.

Regular operation.—The old way of charging the furnace, by hand, is as follows: Ores, flux, and fuel (the 'stock') is brought in buggies from the stock-house to the scales, weighed, hoisted to the top of the furnace, or tunnel-head, wheeled by top-fillers to the bell, and dumped evenly, the fuel separately, the ore and 'stone' (limestone) together. The furnace is kept full to a level just below the outlet of the down-comer. In automatic charging, as indicated in Fig. 121, the stock is charged to the skips, as has been described, and is hoisted to the furnace-top and dumped into the double hopper. No top-fillers are needed, and the bells are often operated from the ground-level, so that no attendant is needed at the tunnel-head.

75. DISPOSAL OF SLAG OR CINDER.

On account of the low specific gravity, slag floats upon the iron. The iron occupies the lower part of the crucible, and accumulates, until it reaches the tuyeres when it should be drawn off. Every 1½ to 2 hours, the plugged cinder-notch is pierced with a pointed steel rod, and the cinder above the level allowed to flow out. It flows along a cast-iron launder a distance of 15 to 30 ft. and falls into a 14-ton slag-car standing on a track below. When loaded the car is hauled by a locomotive to the dump that may be a mile away, and the contents of the ladle is poured out at the side of the track. The track is gradually raised and moved outward toward the edge of the dump as it grows.

A large coke furnace, yielding 500 tons of pig daily, when smelting ores of good grade, produces daily 300 tons of cinder. In smelting silicious ores, the quantity of slag may be twice as great.

76. DISPOSAL OF PIG-IRON.

Every four to six hours the metal is tapped from the furnace, 50 tons at a time. The flow is started by a pointed steel bar which is driven through the clay-plugged iron-notch or tap-hole. A clay-lined launder conducts the flow to ladles similar to the cinder car. Distant from the furnace 10 to 15 ft. is a cross-channel made in the sand. The slag that floats on the stream of iron is diverted into the cross-channel with a skimmer. An iron plate is placed across the flowing stream in such a way as to permit the heavy iron to flow beneath, while the light slag is diverted. A charcoal furnace, having an output of 100 tons per day, produces so little cinder that none is tapped at the cinder-notch, but flowing out with the metal it is skimmed as above described. It is run outside the cast-house upon the ground, is allowed to cool, and is then broken up, and carted away. The

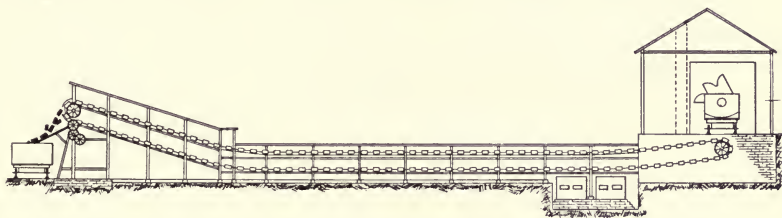

Fig. 126. HEYL AND PATTERSON PIG-CASTING MACHINE.

iron contained in the ladles is called 'direct metal' and is taken to the steel-works and used in molten form.

In practice elsewhere, the iron is cast in molds in the sand of the floor of the cast-house. The floor, 40 ft. wide and 80 to 150 ft. long, consists of the sand in which the depressions are molded and connected by a main-channel or runner, which receives the molten iron flowing from the furnace. The molds fill successively and form pigs of iron weighing 150 lb. each.

To reduce the cost of handling the pig metal, and to give a product smooth and free from adhering sand, casting machines have been introduced in modern plants. Fig. 126 is a Heyl & Patterson pig-casting machine, consisting of an endless-chain conveyor composed of a series of molds, each capable of holding 120 lb. iron. The iron, brought from the furnace in a large ladle shown at *d*, is poured into the molds as they travel slowly along. The pig-iron chills quickly, and by the time it reaches the discharge end, it consists of solid pigs of iron and drops into the railroad car that

is placed in position to receive it. The molds on their return, inverted, take at *c* a spray of whitewash, the water of which quickly dries by the heat of the mold. It leaves a coating of lime inside that prevents the iron from adhering. Mechanical casting has the advantage over casting in sand-molds that it does away with the hot and severe work of breaking and handling the pigs. In hot weather the work can hardly be borne, and there always is difficulty in getting or keeping the men.

Blowing-down.—When a furnace is to be put out of blast, charging is stopped, and a layer of coke is added for the last charge. With continued blast the stock-line descends and the operation progresses as long as iron and cinder can be tapped out, the blast being gradually diminished. Finally the blast is stopped, and the remainder of the content is withdrawn through a hole broken in the brick-work near the bottom.

77. CHEMICAL REACTIONS OF THE IRON BLAST-FURNACE.

A blast-furnace may be likened to an immense gas-producer in which there is a column, 70 ft. high, of alternate layers of coke, iron ore, and flux. The column ranges in temperature from a heat that shows no color at the throat, to a white heat at the tuyeres.

The hot air of the blast, entering at the tuyeres, strikes the white-hot coke with the immediate formation of CO_2 followed by an instantaneous reduction to CO . The air therefore need only burn the fuel to CO as indicated by the following reaction:

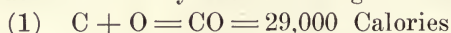

Per pound of carbon burned 2415 pound-calories are generated. Since 23% of air is oxygen, and at the sea-level one pound of air equals 12.38 cu ft., we have $\frac{16}{12} \times \frac{12.38}{0.23} = 72$ cu. ft. of air per pound of carbon, or 61 cu. ft. per pound of coke of 85% carbon.

Fig. 127 shows graphically the chemical reactions under a set of conditions assumed, while the temperature and places where the reactions take place are shown in the section of the furnace at the extreme left in the diagram. To produce a ton of pig-iron (2240 lb.) there is to be used 3520 lb. of 60% iron ore containing 3020 lb. Fe_2O_3 , 1888 lb. coke, and 1010 lb. limestone.

At the tunnel-head, the iron ore (Fe_2O_3) plunges into an atmosphere of 24% CO , 16% CO_2 , and 60% of N at a temperature of 260°C . Reduction of ferric oxide to Fe_3O_4 by the CO begins thus:

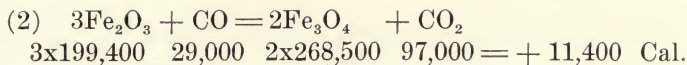

The reaction is completed at a temperature of 450°C. when the ore has reached a depth of 10 ft., shown at 2 of the diagram. During this period, the peculiar reaction resulting in carbon-deposition,

(1) (2) (3) (4) (5) (6) (7) (8) (9) (10) (11) (12) (13)

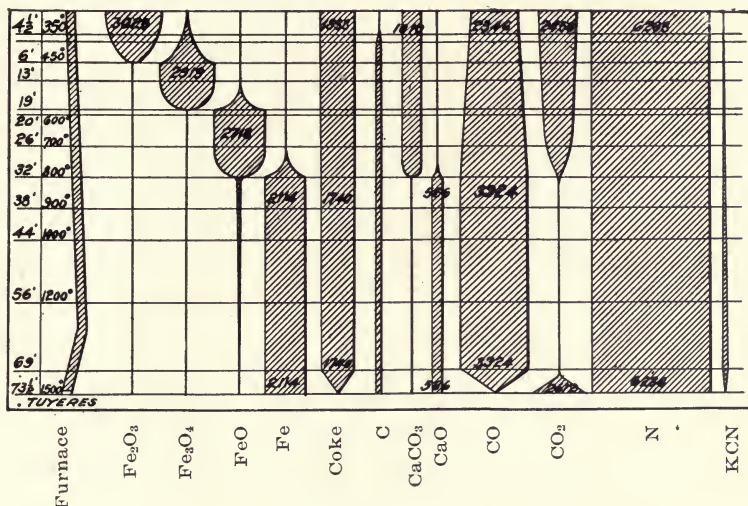
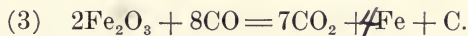
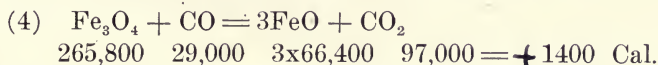

Fig. 127. CHEMICAL REACTIONS OF BLAST-FURNACE.

begins, caused by the reaction of the gas on the ore, forming a deposit of soot or carbon in the pores.



Continuing the descent the ore undergoes further reduction. At a depth of 19 ft. and a temperature of 850°C., the Fe₃O₄ formed, as shown above, has become further reduced to FeO, as indicated in column 4, the reaction being as follows:



The FeO thus formed, impregnated with carbon (See column 7) descends with little change, until at a depth of 26 ft. and at a temperature of 700°C., the CO of the gas reacts upon it, and spongy iron begins to form. The reaction is complete at 800°C., and at a depth of 32 ft., and is as follows:

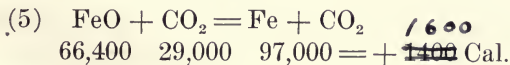

In the passage downward the limestone gradually loses its CO_2 , and at this point the expulsion is complete, as indicated at column 8. The quicklime, column 9, thus formed, unites at the zone of fusion and fluxes the silica of the charge. From the depth of 19 ft. to the depth at which all carbon dioxide is expelled, that is between the temperatures 550° and 880°C ., the CO_2 reacts upon coke, dissolving it according to the following reaction:

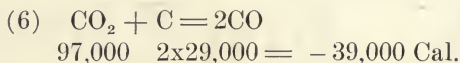

Thus heat is absorbed from the gas, and coke is consumed. The coke, however, as can be seen from column 6, remains but little changed until it reaches the region of the tuyeres.

Below the 32-ft. level at 800°C ., reactions practically cease, the chief action now being a reduction of a small amount of FeO , left undecomposed by the CO . This is gradually reduced (See column 4) by the glowing coke as follows:

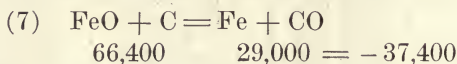

Silicon having less affinity for oxygen than carbon at a high temperature is formed from the reduction of the silica, and as a metalloid enters the pig-iron after the following reaction:



Below the 32-ft. level, the temperature rises gradually and uniformly until the intense combustion at the tuyeres produces 1500°C . as a maximum.

Of the air entering the furnace, 77% is nitrogen, and of the escaping gas 60%, thus showing nitrogen to be by far the largest constituent present. As is shown in column 12, nearly three tons of nitrogen pass through the furnace for each ton of pig-iron produced. At the high temperature of the lower part of the furnace, potassium cyanide is formed, the potash of the coke-ash uniting with carbon and nitrogen to form the salt. It decomposes before the top of the charge is reached.

Referring to columns 10 and 11, we note that the CO_2 formed so freely at the tuyeres, is at once (column 10) changed to CO . The carbon monoxide rises unchanged until it reaches the 32-ft. level, when it begins to act on the iron oxides with the formation of CO_2 . The carbon dioxide from this source united with that from the limestone is the total of the escaping CO_2 gas.

Sulphur occurring as FeS in the coke and as pyrite in the ore, is speedily driven off by the heat of the furnace, giving FeS . The

sulphur of the FeS is taken up by the quicklime, and enters the slag as calcium sulphide according to the following reaction:

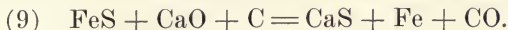

Thus it is separated from the iron upon which it would have an injurious effect.

78. CALCULATION OF AN IRON-FURNACE CHARGE.

To be able to calculate a blast-furnace charge is of prime importance to the young metallurgist. His superior has often not the time or disposition to impart the knowledge to him. The accompanying charge-sheet illustrates the method of estimating a charge for a furnace using coke with an assumed composition of pig-iron and slag. We wish to smelt Mesabi ore, which alone gives too compact a charge for smelting. We accordingly add to it lumpy ore. Since we are using coke that contains sulphur and since we can remove the sulphur from the pig-iron by producing a limey slag, we prescribe the addition of lumpy, silicious, Maxwell ore, with the silica of which we make a slag of the composition given on the charge-sheet, containing a high content of lime to insure the removal of the sulphur, as indicated in equation (9) above.

While the iron ores used in the large iron districts contain little sulphur, the coke may have 0.25 to 2% or an average of 1%. The sulphur must not enter the iron, and by using a slag containing plenty of lime, and hot furnace, the sulphur may be forced into the slag. Thus for a Lake Superior iron ore, using coke, a suitable slag had the composition SiO₂ 35.1%, Al₂O₃ 14.2%, CaO 22.5%, and MgO 22.4%. The iron contained Si 1.4% and S 0.05%. In another instance, in a fairly hot furnace, a slag of SiO₂, 36.1%, Al₂O₃ 12.9%, CaO 41.7%, and MgO 7.3%, took up, principally from the coke, 1.6% S, and produced an iron containing Si 2.15% with only 0.02% sulphur. The slag was quite clean, containing 0.54% Fe.

We will now enter the names of the two ores and the weights (1000 lb. each) as well as the percentage composition, in the two first lines of the charge-sheet, and fill out the corresponding weights of the silica and other constituents. On the next lines, in the same way, we enter the limestone and coke, and tabulate the percentage composition of the limestone.

In the column marked 'Fe' we find the total of iron to be ~~1100~~¹¹¹² lb., approximately equivalent to 1200 lb. of the 92.3% pig-iron given on the charge-sheet. From the experience in smelting such ore we assume that one ton of coke is sufficient for one ton of pig-

iron produced, so that for the 1200 lb. of pig we need 1200 lb. of coke, and we insert this in the table.

The coke carries 11% ash that by analysis is known to contain 40% SiO_2 , 9% Fe, 9% CaO, and 32% Al_2O_3 . The corresponding SiO_2 in the coke will be 11% of the 40% of the ash, or 4.4%, and the percentages in Fe, CaO, and Al_2O_3 will be respectively 1.0% (accurately 0.99%), 1.0%, and 3.5%. The percentage of sulphur as reported by the chemist is based upon the weight of the coke and is written directly with the other percentages. The problem is to determine how much limestone is to be added to obtain a slag of the composition prescribed. The amount can be learned most easily by the following arbitrary method.

CHARGE SHEET.

Name of Ore	Weight			SiO_2		Fe		Bases		Al_2O_3		S	
	H_2O	Wet	Dry	%	lb.	%	lb.	%	lb.	%	lb.	%	lb.
Masabi No. 1552...	12.0	1120	1000	4.0	40	60.0	600			1.0	10		
Maxwell No. 27...	6.0	1060	1000	18.0	180	50.0	500	1.0	10	2.0	20		
Limestone	0.0		700	3.0	21			53.0	371	0.8	6		
Coke.....	3.0	1236	1200	4.4	52	1.0	12	1.0	12	3.5	42	1.0	12
					293		1112		393		78		12
Slag	For Pig = 64					330					Pig		
$\text{SiO}_2 = 34\%$	For Slag = 229					63					$\text{SiO}_2 = 5.4, \text{Si} = 2.5$		
$\text{Al}_2\text{O}_3 = 14$											C = 3.4		
$\text{CaO} = 45$											P = 1.0		
$\text{MgO} = 4$											S = 1.5		
$\text{FeO} = 0.3$													
S = 1.4													

For an approximation, we take an amount (to the nearest hundred pounds) of limestone (700 lb.) equal to twice the silica and alumina of the ore. The weight of all the constituents are carried out, summing them up as shown. The 1200 lb. of pig is to contain 5.4% SiO_2 , or 64 lb., and this deducted from the total, leaves 229 lb. available for the slag. In the assumed slag the ratio of the silica to the bases ($\text{CaO} + \text{MgO}$) is as 34 to 49, or 1 to 1.44. For the 229 lb. of silica we therefore need $229 \times 1.44 = 330$ lb. of CaO. But we have 393 lb. of lime already, or an excess of 63 lb. Since limestone contains approximately half the weight CaO, this becomes 126 lb. limestone or, neglecting decimals less than 10 lb., it becomes 120 lb. Erase the 700 lb. replacing it by the new quantity 580 lb., and amend the calculated amounts in the same line and columns, within the limit of error (10 lb.) in weighing.

The actual percentage of alumina will be in the proportion 229:78::34.0%:12.2%. We can decrease the alumina by using less Maxwell ore; or we can choose from the following table of typical slags, the one nearest in alumina, which would be the one marked 'Lake ore' containing SiO_2 35.5%, bases 49.4%, and Al_2O_3 12.0%. Then a new calculation could be made, using the new slag in place of the one first proposed. Either slag should work well in the furnace.

TABLE OF TYPICAL IRON SLAGS.

	SiO_2 .	FeO .	CaO .	MgO .	Al_2O_3 .	CaS .
Middlesborough, England...	30.0	0.7	32.8	5.3	28.0	1.9
Saulines, France	31.6	0.6	47.2	1.4	17.0	...
Cuban ore	33.2	...	40.7	11.1	13.7	...
Lake ore	35.5	...	40.5	8.9	12.0	...
Lake ore	34.7	1.3	40.1	10.9	11.3	...
Cuban ore	34.5	...	46.5	7.9	10.5	...

79. PIG IRON.

The iron produced in the blast-furnace is not pure, but contains $3\frac{1}{2}$ to 4% carbon and $1\frac{1}{2}$ to 3% silicon. Some of the carbon is combined chemically, some separated by graphite. If a large proportion is combined, the metal is hard and the fracture of the iron looks white. If a large proportion is free, the fracture is a gray or black with scales of graphite, and the iron is soft and tough.

Under 'Chemical Reactions of the Iron Blast-Furnace,' equation 3 indicates the formation of carbon, and equation 8 the reduction of silica to silicon, both elements entering the pig-iron. A small amount of sulphur, seldom less than 0.2 and often 0.25% or more, is present. As the amount increases above 0.1% the iron becomes harder and more brittle.

The percentage of silicon and sulphur in the iron depends in large measure upon furnace-conditions; hence it can be controlled; but all the phosphorus present enters the pig-iron. In pig-iron for steel manufacture by the usual, or acid bessemer process, the phosphorus in the pig must not exceed 0.10%. Therefore, in the ore, it must not be higher than 0.05 or 0.06%. In the acid bessemer process the phosphorus is not eliminated, and it tends to make steel red-short (brittle when hot) a quality that interferes with the subsequent rolling. Phosphorus, on the other hand, imparts the quality of fluidity to cast-iron. Iron that contains 3% P is in demand where intricate castings are to be made, and can be used where brittleness is of minor importance.

Cast-iron as compared with steel and wrought iron has the following characteristics:

(1) It is brittle because of the presence of the metalloids, carbon, and silicon.

(2) Because of the presence of the metalloids it is fusible; and it derives thus the most valuable property. It runs freely from the blast-furnace and can be cast in intricate molds to form castings of any kind. Wrought iron at the same temperature would be pasty and would not run. Steel, which is intermediate between wrought-iron and cast-iron in the contained carbon, can be made into castings, however, but not readily like cast-iron. The making of steel-castings is becoming more common.

(3) It cannot be forged either hot or cold.

Pig-iron is graded according to the appearance or the fracture of a freshly broken piece, into several classes or grades ranging from a soft-gray to a white iron as below.

ALABAMA PIG IRON.

Grade.	Graphite carbon.	Combined carbon.	Silicon.
Silver gray	3.13	0.02	5.5
No. 1 soft.....	3.48	0.03	3.5
No. 2 soft.....	3.53	0.03	3.5 to 4.0
No. 1 foundry.....	3.49	0.07	2.8 to 3.5
No. 2 foundry.....	3.55	0.07	2.2 to 2.6
No. 3 foundry.....	3.48	0.10	2.0 to 2.4
Gray forge	3.00	0.57	1.3 to 1.7
Mottled	2.11	1.22	1.1 to 1.6
White	0.10	2.92	0.7 to 1.2

This table shows the increase of combined carbon, and the decrease of silicon, as the grade approaches white iron.

The first grades are more difficult to make, and command a higher price as shown by the following quotations on Southern or Alabama pig-iron, per long ton:

No. 1 soft	\$18.75
No. 2 "	18.25
No. 1 foundry	18.75
No. 2 "	18.25
No. 3 "	17.50
No. 4 "	17.00
Gray forge	16.50

PART VI. COPPER

PART VI. COPPER.

80. COPPER ORES.

We are to think of copper ores as mineral aggregates, carrying frequently 10 to 15% copper or less, with associated minerals and an earthy gangue. Treating the ore, is a problem not only of obtaining the copper, but of separating and eliminating the gangue and associated minerals. Though there are many kinds of copper ores, those of commercial importance are few in number. We may divide them into three classes (1) the sulphides; (2) the oxides, including the carbonate and silicate; (3) ores containing native copper.

Sulphides.—Chalcopyrite, CuFeS_2 , when pure contains ~~native~~ 34.4% copper. This is by far the most widely distributed and most abundant of the ores of copper, and furnishes the world's principal supply of the metal. It is frequently accompanied by iron pyrite, and has silicious gangue even when the sulphide is massive. In consequence, the ore often carries no more than 3 to 4% copper, but it is particularly suited to pyrite smelting. Silver and gold are found in the ore in small quantity. The deposits at Mt. Lyell, Tasmania, that have been so successfully worked by pyritic smelting, are chiefly of massive iron-pyrite, containing chalcopyrite, and carrying 4.5 to 5% copper with 0.15 oz. gold and 3 oz. silver per ton.

Chalcocite (copper-glance), Cu_2S , is computed to contain 79.7% copper, but it is seldom pure even in the crystalline form, the copper having been replaced by iron and other metals. The impure mineral shows the characteristics of the pure mineral when carrying as little as 55% copper. The pure crystals resemble the artificial product 'white metal,' a high-grade copper matte produced in the furnace.

Bornite (peacock ore), Cu_3FeS_3 , when pure contains 55.6% copper. It is found associated with chalcopyrite and chalcocite in proportions varying from 42 to 70% copper, without losing the characteristic varied colors.

Enargite ($4\text{CuS} + \text{Cu}_2\text{SAs}_2\text{S}_3$), 48.6% copper, an arsenide, occurs in Butte, Montana, ores.

Tetrahedrite (gray-copper, fahlerz), ($\text{Cu}_2\text{S,FeS,ZnS,Ag}_2\text{S,PbS}$), ($\text{Sb}_2\text{S}_3,\text{As}_2\text{S}_3$), may be computed as containing 30.4% copper, but it varies greatly in the copper and silver content. It has already been mentioned as a silver ore. Because of the contained arsenic and antimony, it is unfavorable as a copper ore, and it is only because of the richness in silver that it is treated.

Oxides, carbonates, and silicates.—These ores are the result of the decomposition of the copper sulphides, by air and water. We find them in the upper zones of mineral deposits accompanied by iron oxide which also is the result of the decomposition of iron sulphide. As we sink on the vein we find the oxidized ore of the upper levels giving place in depth to the unaltered sulphide.

Cuprite (red copper-oxide), Cu_2O , 88.8% copper, is a product of decomposition. It often permeates large masses of iron ore. Large lumps of the ore are sometimes found, the center of which contains unaltered metal. These evidently are the result of the oxidation of a mass of native copper.

Melaconite (black oxide of copper), CuO , contains when pure 79.8% copper. The ore, with the copper in part replaced by oxides of iron and manganese, is sometimes found in masses large enough to pay for extraction, and containing 20 to 50% copper. The so-called black oxide of the Blue Ridge region, on the border of Tennessee, North Carolina, and Virginia, seems to be an intimate mixture of copper glance, black copper-oxide, copper carbonate, and native copper with iron oxide and sulphide. The ore can be readily roasted in lump form.

Malachite, $\text{CuCO}_3, \text{CuOH}_2\text{O}$, 57.3% copper, occurs widely distributed, ordinarily in non-paying quantities as a decomposition product in surface deposits, but sometimes sufficiently rich to work. It is found mixed with limestone, dolomite, oxides of iron and manganese, and silica. It is difficult to judge the copper-content of the ore from the appearance, but the green color makes its presence readily recognizable.

Azurite, $2\text{CuCO}_3 + \text{Cu}_2\text{OH}_2\text{O}$, is computed to contain 55.2% copper. The ore is blue, as the name indicates, and the appearance is striking. It occurs in the same way as malachite, and often is associated with malachite, but it is less abundant, and often is only a coloring on other oxides.

Chrysocolla, a hydrated silicate of copper, containing when pure

40% copper, is a decomposition product of copper sulphide, and is often accompanied by malachite.

Native copper.—Native copper is found extensively in the copper region of Lake Superior. Elsewhere it occurs sparingly and is not commercially important though it often accompanies the oxidized ores. In the Lake Superior region it is found in wide lodes disseminated through the lode-matter 0.5% to 4% of the whole, and even when of the lowest grade mentioned, by concentrating can be recovered at a profit. The concentrate or 'mineral,' as it is locally named, is produced in different grades, ranging from 30 to 94% copper. Much of the native copper is pure; in other instances it carries a little arsenic.

81. THE EXTRACTION OF COPPER.

Copper may be extracted from the ore by dry or by wet methods. By the dry method the ore is smelted, the process being one of igneous fusion. By the wet or hydro-metallurgical methods the copper is leached from the ore. The striking point of difference between the two methods is that, in the first, we change the form of the entire mass by smelting into a fluid, effecting then a separation of the copper from the worthless part, while in the wet method we act upon the copper alone, leaving the greater part of the ore in the original condition.

The dry or igneous methods.—Probably more than 90% of the world's production of copper is by smelting. The methods of smelting vary with the nature of the ore. We may divide them into the following:

- (1) The smelting of the oxidized ores of copper in blast-furnaces.
- (2) The blast-furnace matte-smelting of the roasted sulphide of copper.
- (3) The blast-furnace matte-smelting of raw or unroasted copper sulphides (pyrite matte-smelting).
- (4) The reverberatory smelting of roasted sulphide with or without oxidized ore.

Of the above methods, the first gives the copper in metallic form, while the second and third are merely concentration processes by which the copper is concentrated into a small product from a large bulk of the original ore. The product, or matte, has to be further treated before the copper is recovered from it. The copper, or copper-matte, produced in the above operations carries with it

the gold and silver of the ore. It thus becomes a collector of the precious metal.

82. COPPER SMELTING OF OXIDIZED ORES.

This resembles the smelting of iron ores in that metal is obtained in metallic form in one operation. The ore, which does not contain sulphur, is charged into a blast-furnace and smelted with coke for fuel. The products are slag and blister-copper, the latter being metallic copper containing impurities that have been taken up in smelting, much as carbon and silicon are absorbed in iron smelting.

In the southwestern part of the United States (New Mexico and Arizona) and in Mexico, ores are found that contain copper in the form of malachite, cuprite, chrysocolla, and the native metal. Being nearly free from copper sulphide, they have been treated for the recovery of the copper by a single operation. As compared with matte smelting the process has the advantage in that it yields nearly pure copper (97 to 98%) while in matte-smelting the blast-furnace product is 40 to 50% copper. The objection to the method has been that separation of copper from the slag is not complete. The slag resulting from the operation is 1.5 to 2% copper, while in matte-smelting it is only 0.5%. The method therefore has fallen into disuse, and can be revived only where suitable oxidized ore is found, distant from railroads, and where no sulphides are present to mix with it and form matte.

Fig. 128 is a sectional elevation of a blast-furnace building suited to the smelting of oxidized copper ores. It has two floors or levels, the upper, called the charge-floor, and the lower, the slag-floor. The ground at the right drops away and furnishes a place for a dump. The ores are stored in bins at the charge-floor level, and are brought in weighed charges to the furnace door, the sill of which is flush with the charge-floor. This door is shown also in Fig. 129. The slag and blister copper are withdrawn near the bottom. Behind the furnace is seen the pipe or blast-main by which air is conducted to the wind-box at the tuyeres. The furnace stack extends above the roof, and removes the escaping gas.

Fig. 129 is a view of a blast-furnace for the production of blister copper from oxidized copper ores. At the bottom are seen the two half drop-doors which, when the furnace is running, are swung up into position to close the bottom of the furnace. On them is placed the bottom lining of brick. The wall within the curb is lined with fire-brick as high as the tuyeres forming the crucible. The water-jacket, including the tuyere-openings into the furnace, extends up

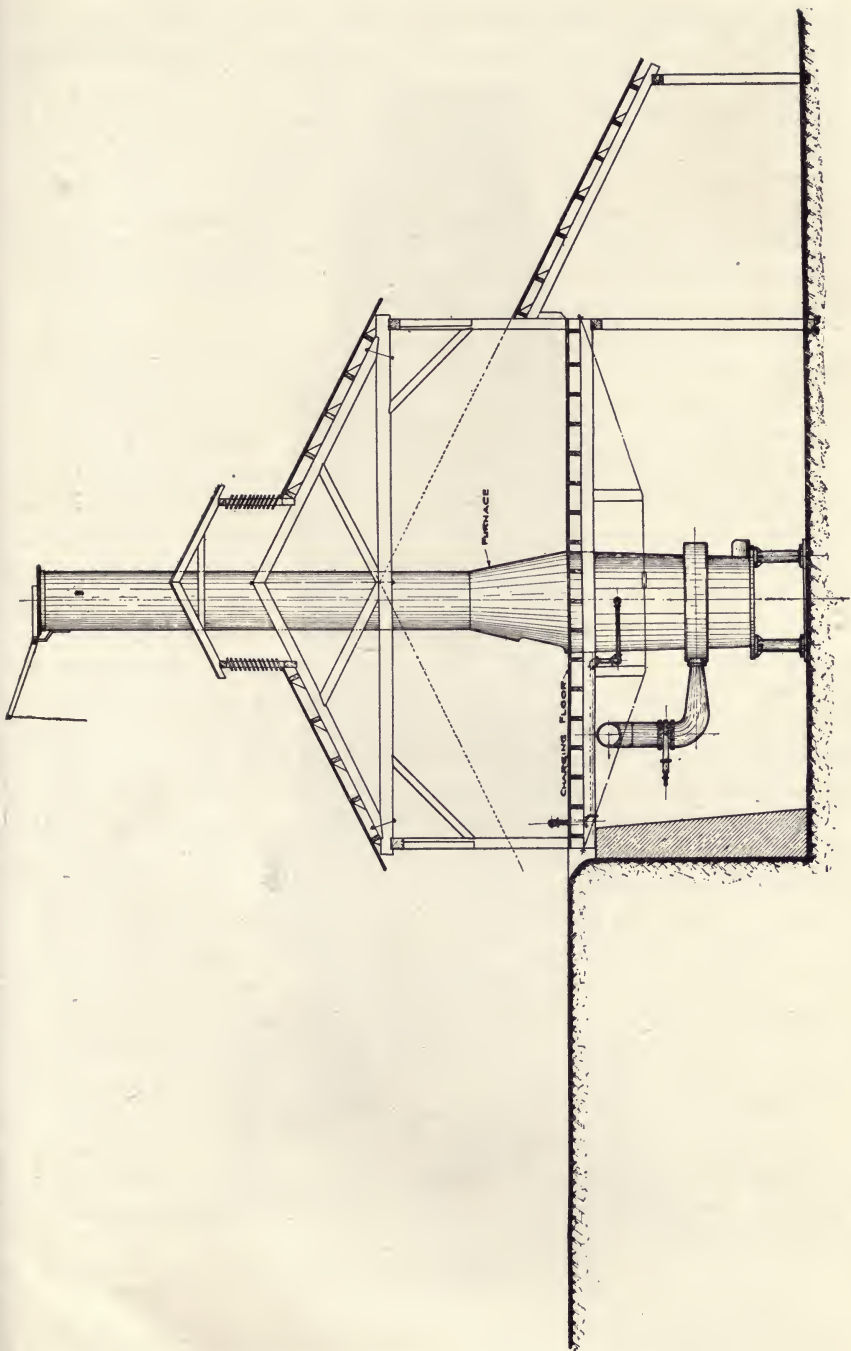

SECTION THROUGH SMELTING ROOM

FIG. 128. COPPER SMELTING PLANT.

to the feed floor. It consists of an inner and an outer plate with space between in which water flows, continually escaping through outlet pipes at the top of the jacket. Thus, while the inner plate is in contact with the highly heated content of the furnace, it is kept cool and is not melted or attacked by the slag. The water-jacket is surrounded by a wind-box as shown. There are six tuyere-openings, having covers with mica-covered peep-openings by means of which the condition of the tuyeres can be observed. The base-plate rests upon four iron columns that are supported by a solid-stone or concrete foundation.

The crucible contains the molten contents of the furnace, the copper below and the lighter slag floating upon it. There are two tap-holes and two spouts; the lower, close to the bottom, is to remove the molten copper, the upper, a few inches higher, is to withdraw the slag. From time to time, as slag or copper accumulates, it is withdrawn by piercing a hole through the clay-stopping of the tap-holes by means of a pointed steel tapping-bar. The flow is arrested by thrusting into the opening a plug of clay stuck on the end of a button-headed stopper-rod or dolly. The slag is received into a slag-pot, Fig. 135, mounted on wheels, which when filled, is pushed out and poured over the edge of the dump. The copper is received in a 'bullion mold,' which after filling, is set aside until the copper has solidified. The ingot is then dumped out and the mold again used. The furnace shown is a round one, 36 in. diam. inside, thus having a bosh or enlargement of six inches on the side.

In operation, the furnace is kept full to the feed-door with alternate layers of fuel and charge. The blast rises through the column of materials a distance of seven feet and passes off through the stack, which has sufficient draft to take away the gas and smoke and also the air that enters the feed-opening or door. The blast enters under a pressure of 12 oz. per sq. in. causing an intense combustion of the coke and the fusion of the charge. The copper, reduced by the glowing coke, collects in drops and finds its way to the bottom of the crucible, while the gangue of the ore, fluxed by the addition of iron ore and limestone, forms a fusible slag.

The cost of treatment of oxidized copper ore may be stated to be \$8 per ton. The slag contains 1.5 to 2.5% copper, so that, under the best circumstances, we rely on recovering 82% copper, while of the silver 91% is obtained.

83. MATTE-SMELTING.

If we smelt copper-bearing sulphide ore in the blast-furnace

described, with added fluxes to form a fusible slag, we form an artificial sulphide or matte of 23 to 25% sulphur. The copper that



Fig. 129. BLAST-FURNACE FOR OXIDIZED COPPER ORES.

was in the ore and the iron from the charge enter the matte, but the quantity of matte so formed is but little less than that of ore originally put into the furnace. If, however, we first roast the ore, the quantity of sulphur present, and consequently the amount of matte made, is less, and the ratio of the ore to the matte may be five or ten to one. In the matte will be the copper as a sulphide, and in forming, the matte will take up the silver and gold of the ore. By this operation we collect the precious metals in a product one-fifth to one-tenth the original ore, the matte being termed a 'collector.' It then can be further treated to convert it into metallic copper carrying the precious metals. By the process of electrolytic refining, the gold and silver are eventually separated from the copper. A charge, suited to matte-smelting methods, would therefore consist of roasted ore retaining 7% sulphur with oxidized copper and copper-free ores containing gold and silver added for the precious-metal content. It would also carry fluxes to make a fusible slag and supply iron for the matte.

The products of the furnaces are slag and matte. The former is the result of the union of the silica in the charge with the various bases, chiefly iron oxide and lime. The latter is the complex artificial sulphide produced by the sulphur in the charge combining with copper and iron. The affinity of sulphur for copper is greater than for iron, and it takes the former first; then if it needs iron it takes that also, until a compound of both has been formed that contains approximately 25% sulphur. Any further iron present enters the slag. As the ratio of the amount of the iron thus available, to the amount of other bases, varies, so will the slag vary in composition; but the principal requirement is that the quantity of silica be enough to form a fusible slag. Slags of 25 to 40% silica are common in copper-matting practice, and the lower limit is sometimes exceeded, when for economy in smelting, it is desired to use as little flux as possible.

84. THE COPPER-MATting BLAST-FURNACE.

For producing matte from copper-bearing ores, whether these are to be smelted after roasting or treated raw by the method of pyritic smelting, we use the furnace, Fig. 129, already described, or one of the rectangular type, Fig. 130 and 131.

Fig. 130, at the left, represents a transverse sectional elevation of a furnace of 42 by 120 in. interior hearth-dimensions, having 18 tuyeres, nine at each side, and a capacity of 150 tons of charge daily. Fig. 131 is a perspective view of a similar furnace, showing

the iron-work as high as the feed-floor, but differing from Fig. 130 in having a trapped slag-spout, more fully shown in Fig. 133.

The sole-plate of the furnace rests on jack-screws, and can be lowered and set aside when it is desired to make repairs or

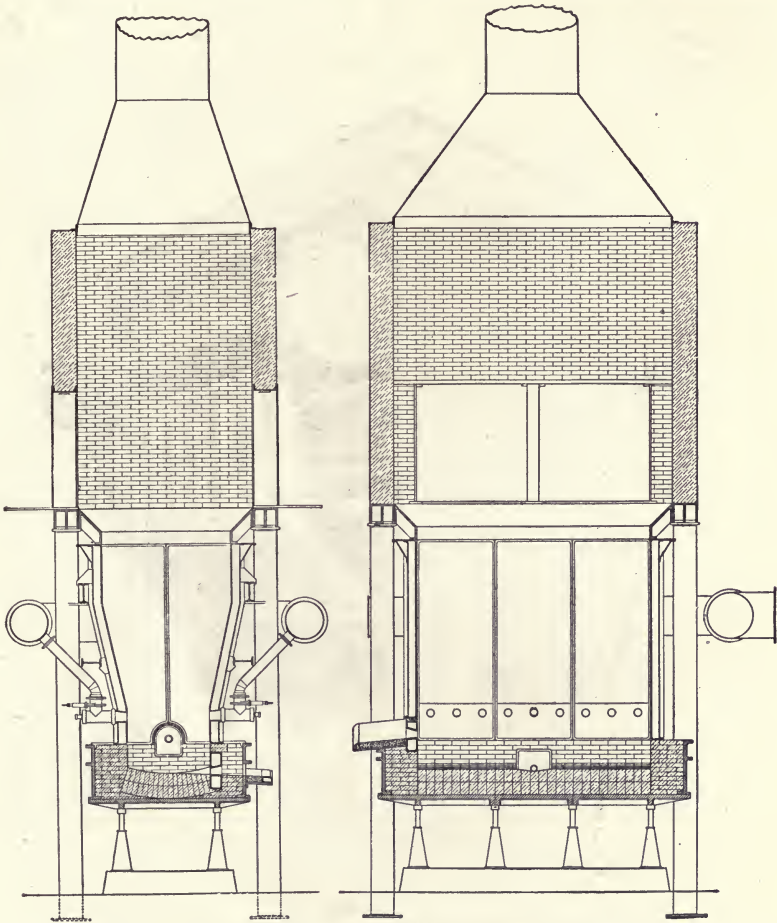

Fig. 130. COPPER MATTING BLAST-FURNACE.

to clean out the furnace. It is protected from the action of the molten matte and slag by a 9-in. layer of fire-brick. In Fig. 130 are seen crucible plates which rest upon the sole-plate. These are lined with 18 in. of brick. The jackets shown in Fig. 131 extend down to the sole-plate and the water-cooling is sufficient protection from the action of the molten materials. The sole-plate within the furnace, however, is covered by the brick lining. The

jackets, shown best in Fig. 132, are at least 9 ft. high, and in the furnace represented, there are two of them on each side, and one at each end. At one end the jacket is shorter, and the space below is filled with a water-cooled tap-jacket through which the slag is withdrawn. In Fig. 130, the longitudinal view shows the arrangement of a furnace with three jackets at each side, and two jackets at each end. The small jackets are easily handled and

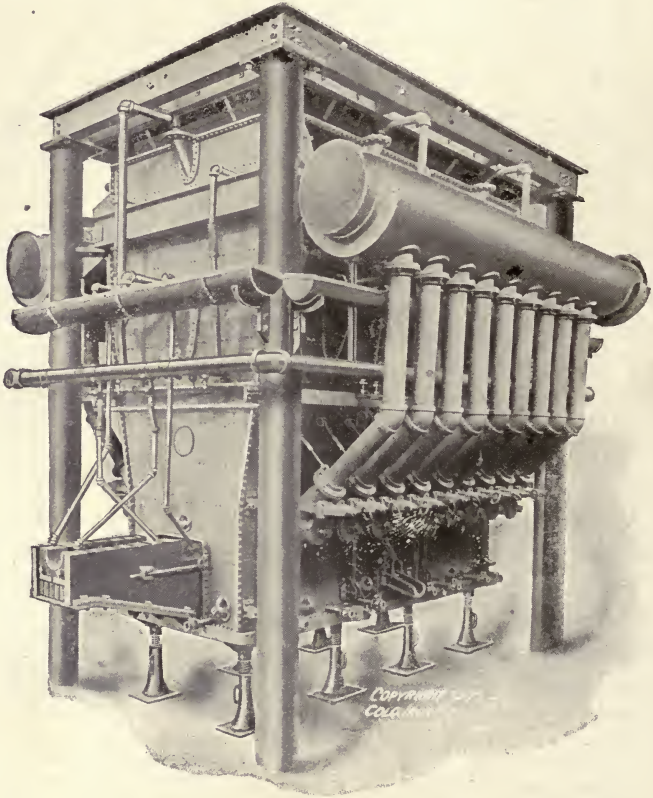

Fig. 131. VIEW OF COPPER MATTING BLAST-FURNACE.

replaced. In Fig. ¹³²~~130~~ the inlets for water are at half the height of the bosh, and the water outlets are at highest point to keep them full of water. They are tied or clamped together with heavy angles, but in the other figures, with I-beams.

Fig. 133 is a water-cooled trapped spout used in connection with the furnace as indicated in Fig. 131. Through it flow the slag and matte. Before the slag can overflow it must fill the spout

and cover the outlet or tap-hole through the jacket. It thus prevents the escape of the blast, and flows in a regular stream as fast as it forms within the furnace. The furnace shown in Fig. 130,

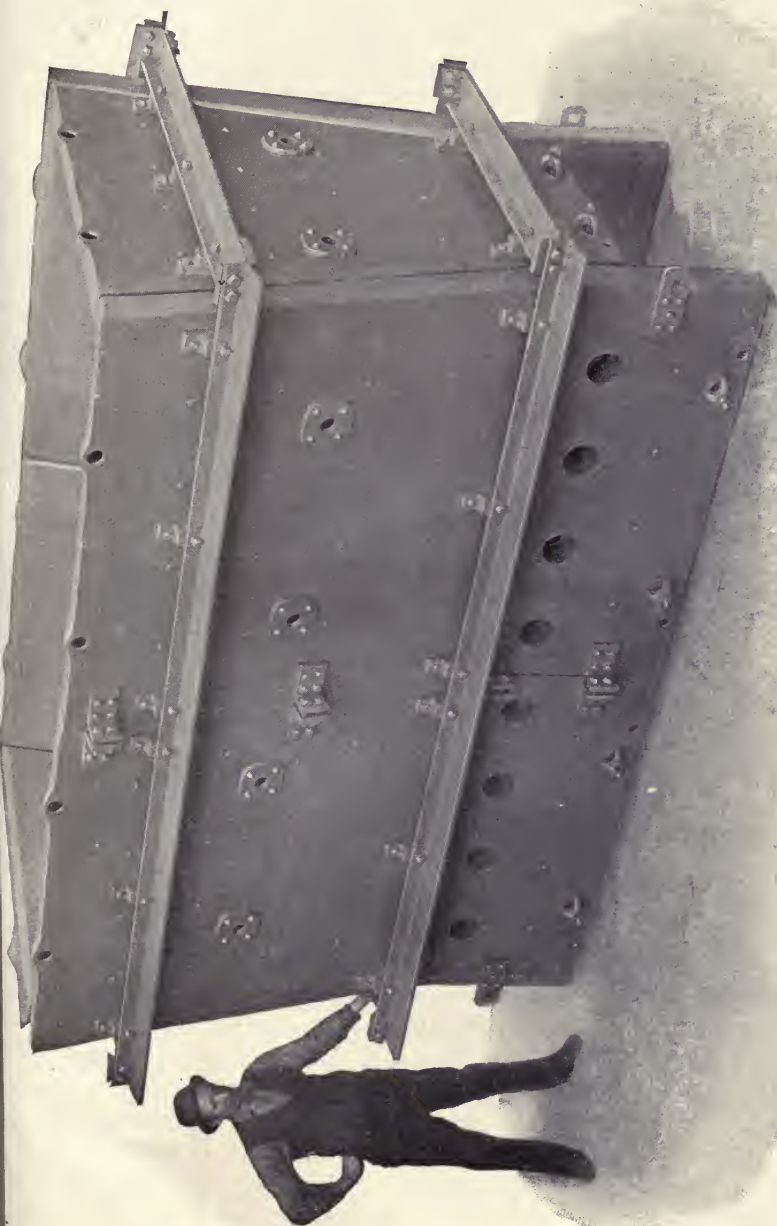

FIG. 132. STEEL WATER JACKETS.

is arranged differently. There is a spout and a water-cooled tap-jacket at the end of the furnace through which the slag is removed, while the matte, as it accumulates, is removed by a spout and a side tap-hole at the level of the crucible-bottom. In this case, the separation between the slag and matte is effected within the furnace; in the former case, where the trapped spout is used (since matte and slag issue together) they are separated outside the furnace in the fore-hearth or settler Fig. 134.

The fore-hearth, made of cast-iron plates, 4 by 6 ft. inside dimensions, is lined with a layer of brick, and is mounted on wheels

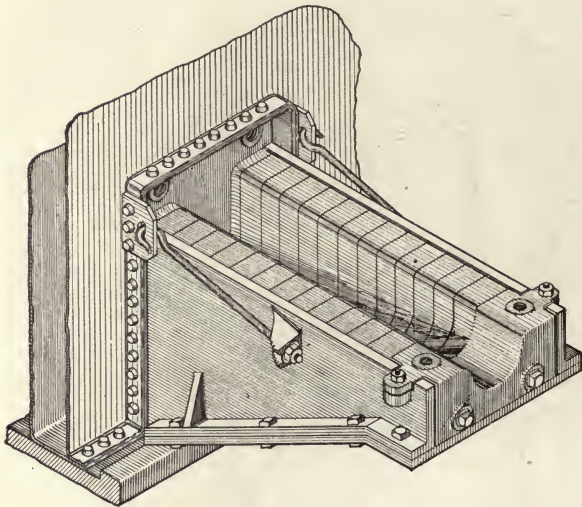

Fig. 133. TRAPPED SPOUT.

so that it can be quickly set aside and a new one put in the place when needed. The slag and matte flow into it at one end and keep it full of molten slag. At the other end, the slag flows out. The matte settles on the way and collects in the bottom of the fore-hearth, and, when accumulated, is tapped at the tap-hole and spout, seen at the side. Meanwhile the slag, flowing from the fore-hearth, is caught in slag-pots, Fig. 135, and taken to the edge of the dump and poured. The slag cools on the surface of the fore-hearth and forms a crust from beneath which the molten slag flows. Crust forms also at the sides and bottom, and becomes gradually thicker; and after several days becomes so thick that the molten part of the interior is too small to permit of a good

separation of the matte from slag. When this results, the fore-hearth is pried back on the wheels, and replaced by another. In the furnace, Fig. 131, at the middle side-jacket, another tap-hole furnished with a spout is seen. This is generally kept closed, but is opened when it is desired to empty the hearth of the matte and slag.

The transverse view, Fig. 130, shows the side-jackets. These

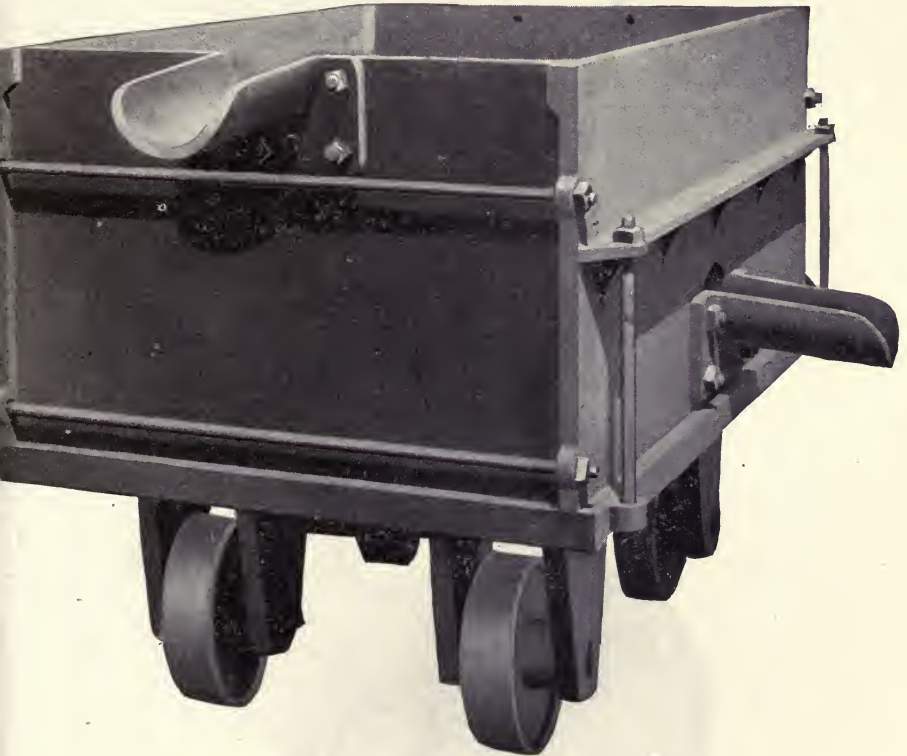

Fig. 134. FORE-HEARTH.

have brackets or knees riveted to them and rest on I-beams that are secured to the columns. Thus, when the sole-plate is removed, the jackets are not disturbed. The distance between the side jackets is 42 in. at the tuyeres, and 66 in. at the top. The bosh, or enlargement, is thus 12 in. on the side. Above the jackets are the cast-iron distributing plates, forming the sills of the feed-doors. The feed-doors in the opposite long sides of the furnace make it accessible from end to end, not only for feeding and trimming the

charge, but for cutting with chisel-bars the accretion or scaffolding that may form on the interior surface of the jackets.

The portion of the furnace above the feed-floor level, called



FIG. 135. SLAG POT.

the stack or top, is of brick supported by a deck-plate or mantel-plate of I-beams resting on the cast-iron columns that extend down into the foundation. The upper portion of the stack is a hood of sheet-steel terminating in a pipe that extends through the roof of the furnace building. Sometimes a branch pipe leads from the hood to a dust-chamber where the dust is collected.

The bustle-pipe, by which the blast at a pressure of $\frac{3}{4}$ to 2 lb. is brought to the furnace, extends around three sides and connects by the sheet-metal pipes to the tuyeres, shown in detail in Fig. 136. The tuyere is 6 in. diam. and has a 6-in. screw-cap into which is inserted a nipple with a cap having a mica-covered peep-hole,

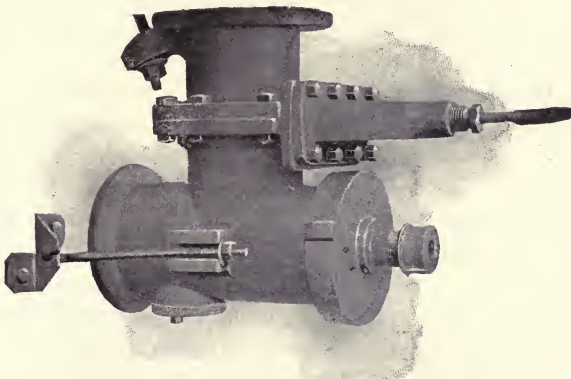

Fig. 136. TUYERE.

through which the condition of the furnace can be observed. At the branch above the tuyere is shown a slide-valve. In Fig. 131, just below the bustle-pipe, is a waste launder to receive the overflow from the jackets, and below it is a 3-in. water-supply pipe branching to each jacket, and to the water-cooled trapped spout at the front.

85. LARGE FURNACES AND FORE-HEARTHS.

The tendency of late years has been to increase the size of copper-matting blast-furnaces. Increase in width would require higher blast-pressure to drive the air to the center of the furnace; hence increased capacity had to be gained by increasing the length of the furnace. At the same time, to supply more air, the blast pressure has been increased in some cases to 40 oz. or $2\frac{1}{2}$ lb. per sq. in. A furnace 56 by 180 in. under these conditions smelts 400 tons of ore daily. For the matte to properly settle from the slag,

with so large a flow, a cylindrical fore-hearth has been used 16 ft. diam. by 5 ft. deep, exterior dimensions, lined with fire-brick. In the pool of molten material incrustated with slag, the separation is effected. The molten content of the furnace flows into it on one side and the slag flows out at the opposite side. From time to time the fore-hearth is tapped at the lower tap-hole, and five to ten tons of matte are drawn into a ladle, that takes the matte to a converter for further treatment to obtain the copper contained. The lengthening of the furnace has been carried so far that, at the Washoe plant, Anaconda, Montana, a furnace 51 ft. long, having 1600 tons daily capacity has been for some time in operation, and recently one 87 ft. long and 3000 tons daily capacity has been built and operated. The first furnace has two fore-hearths, each 16 ft. diam., and the second three of that size.

Ore for matte-smelting.—Ores suitable for matte smelting are the oxidized ones containing little or no sulphur; ores that have been roasted; and ores that are silicious and oxidized containing gold and silver. Ores that require to be first roasted are better roasted in lump form in heaps or stalls, for the reason that the blast-furnace, because of its strong air currents, is not suited to smelting fine ore. The amount of matte made (matte fall) depends upon the quantity of sulphur in the charge, and to get sufficient concentration (little matte from much ore) the sulphur is kept low. To the ore above described is added limestone and iron ore as flux, and a quantity of fuel equal to 10 to 15% of the charge.

Starting the furnace.—Since a blast-furnace is water-jacketed the operation of warming it is a simple one. The fire-brick lining of the crucible is dried and warmed by several hours heating with a wood fire. The end and side tap-jackets are removed to permit the air to enter to the fuel. When the hearth is hot the wood ashes are scraped out and a fresh fire of wood, filling the crucible a foot deep, is started, wood of uniform-sized pieces for uniform burning being selected. Upon the wood is placed charcoal, and upon the charcoal, coke, until the surface is $1\frac{1}{2}$ to 2 ft. above the tuyeres. The fire is increased uniformly and regulated by checking the draft at the front and admitting air at the rear as required. When the coke is thoroughly ignited the furnace is ready for charging.

The brick-lined fore-hearth is warmed while warming the furnace. The wood is placed carefully against the walls, leaving the center clear for the air to reach the fuel so that the burning may proceed actively. As the wood burns, charcoal and ashes

accumulate, and are shoveled out, since otherwise they form a layer through which the heat does not penetrate.

Suppose the charge of ore and flux to be 2000 lb., and that we intend, as in regular work, to use with it 12% coke or 240 lb. per charge. We put in a layer of 240 lb. coke, then one of 500 lb. slag. This is followed by a half dozen charges each of 240 lb. coke alternated with 1000 lb. slag. Next we put in a half dozen charges of 240 lb. fuel and 2000 lb. slag, so that the slag when melted shall entirely fill the fore-hearth. We now begin feeding the regularly calculated charges and required fuel. At this time the blast is admitted, gently at first, gradually increasing during a half hour, after which the furnace should be in full blast. Extra men should now assist in charging to rapidly fill the furnace. At the slag floor, before the blast is turned on, the tap-jackets and the trapped spout are put in place, and all openings closed with plugging mixture or 'adobe.' The adobe may be obtained from a neighboring bank, if of suitable quality, or may be made from coarsely ground fire-brick mixed with clay.

As the smelting proceeds, by looking into the tuyeres, we see that the slag is rising to their level. We then open the tap-hole and permit the slag to flow into and quickly fill the fore-hearth. The excess steadily overflows to the slag-pots set to catch it, or it may be granulated and removed by water.

When feeding the furnace care is taken to distribute the charge evenly, not feeding coarse ore in one place and fine in another. Unless we exercise care in this regard we have irregular operation, blast and flame coming up in one place and the charge looking dead in another. When this begins to occur we load the active places with charge, feed lightly, and use coarser material where there is little action.

We may adopt either the intermittent or the continuous method of removing the slag from the furnace. In the intermittent method, as arranged in Fig. 130, the slag is tapped from time to time as it accumulates as already described, taking care that it does not gather in such quantity as to rise to and run into the tuyeres, or to 'slag' them as it is called. By the continuous method, the slag and matte flow continuously from the furnace through the trapped spout, Fig. 131 and 133. The molten products enter a fore-hearth and the separation of slag from matte is there made.

86. REGULAR OPERATION OF THE FURNACE.

The furnace being filled to the feed-doors, we have a 7-ft. smelting column (distance from tuyeres to feed-door). As the

charge smelts and the molten materials are withdrawn, the surface gradually sinks, making room for further additions. The coke is first added in a layer over the surface, and upon it is spread the weighed charge. The air under pressure from the blowers, driven into the furnace at a pressure not less than $\frac{3}{4}$ lb. or 12 oz. per sq. in., burns the descending coke mostly at the tuyeres. The resulting gas with the sulphur dioxide from the burning sulphur in the charge appears as a whitish smoke mingled with dust mechanically carried. This passes from the furnace-top directly into the air, or to a dust-chamber and thence to the stack. The sulphur remaining unites with the copper and a part of the iron and forms a matte or copper-iron sulphide. The matte, in forming, comes into contact with the gold and silver contained in the ore of the charge and absorbs them. The coke reduces the iron not needed for the formation of the matte to ferrous form, and the ferrous iron, with the lime, alumina, and other bases, combines with the silica to form a slag, fluid at the high temperature prevailing at the tuyeres.

The molten slag and matte flow from the furnace to the fore-hearth where the separation is effected, and the supernatant slag, freed from the matte, escapes by an overflow spout, and is received into slag-pots and conveyed to the dump. Another means of disposing of the slag is to allow the stream of slag from the fore-hearth to fall into a launder and be caught by a horizontal jet of water to break it into drops and cool it in granules about wheat-size. The granules are carried away by the water, in a cast-iron-lined launder to the dump. The matte is tapped from the fore-hearth as it accumulates, through a tap-hole near the bottom, and flows over the matte spout shown at the right of the transverse section, Fig. 130.

87. MATTE.

Matte is an artificial sulphide formed in smelting in result of the union of sulphur with bases. Iron sulphide (FeS), such as is used in the making of hydrogen sulphide in the laboratory, is the simplest form. To produce it in small quantities, a covered assay crucible may be filled with shingle-nails and brought to a white heat in a wind-furnace and roll-sulphur added gradually until the content fuses. The sulphide is then poured, and broken for use. In smelting a charge containing sulphur, scrap-iron will take up the sulphur and form matte. If copper oxide or copper sulphide is present in the charge, the sulphur takes the copper to form the matte in preference to taking the iron. When the copper

is exhausted, the excess of sulphur expends any combining power that may remain by taking iron. We thus have a copper-iron sulphide, called copper matte. If lead or nickel are present in the charge, they partly enter the matte. Magnetic iron oxide, taken from the charge, also enters the matte. Thus we get, finally, a complex compound, as the following table shows:

COMPOSITION OF COPPER MATTE.

	Cu, %	S, %	Fe, %	Fe ₃ O ₄ , %	Sp. gr.
Anaconda reverberatory furnace.....	60.76	23.25	11.43	1.13	5.4
Reverberatory furnace (Butte, Mont.)....	29.41	23.70	25.35	12.60	4.8
Blast-furnace (Butte, Mont.).....	36.15	23.38	24.97	8.51	5.1
Blast-furnace (Jerome, Ariz.).....	55.00	23.96	13.85	2.58	5.3
Blast-furnace (Elizabeth, Vt.).....	21.36	22.95	41.03	10.44	4.7
Blast-furnace (Sudbury, Canada).....	24.54	23.24	28.65	7.32	5.1

The Sudbury matte contains also 15.56% nickel replacing copper. It will be noted that the percentage of sulphur (23 to 24) is approximately the same in all cases.

88. SLAG.

Variation in slag composition is permissible in copper-smelting; the requirement being that the slag be fluid to flow from the tap-hole of the furnace. Slags having the maximum content of silica and of bases, as shown below, are employed successfully in the blast-furnace.

In silver-lead smelting practice, such variations are not allowable. Slags varying from the composition found in practice to be satisfactory, even though they be fluid and run well, carry off both lead and silver. In copper practice such slags would be clean and free from copper.

THE COMPOSITION OF SLAGS.

	SiO ₂ , %	FeO, %	Al ₂ O ₃ , %	CaO, %	MgO, %	ZnO, %	BaO, %
Minimum	20	2	2	2	0	0	0
Maximum	57	70	18	40	8	20	42

A slag low in silica could not carry much of the alkaline-earth bases, and would be high in iron, and of a specific gravity over 3.7. A silicious slag would work well with a heavy limey base, and would have a specific gravity of 3.5. Since the separation of slag from matte results from the difference in specific gravity of the two substances, we expect a better separation the lighter and more silicious the slags. Matte takes up zinc sulphide, where much is present, and becomes lighter, so in this respect, zinc is detrimental to effective separation.

89. CALCULATION OF CHARGE FOR MATTE SMELTING.

A suitable charge may consist of roasted ore, oxidized copper-ore and silicious ores containing gold and silver. The requirement is that the charge contain copper-bearing ore, and enough sulphur to form with the copper a suitable matte that will take up the gold and silver that the charge contains. Enough flux is added to the charge to make a suitable slag, and 10 to 15% coke or charcoal to smelt the mixture.

The products from the furnace are slag and matte, the former being the result of the union of the silica of the charge and the fuel, with the bases that are present. A part of the sulphur in the charge is volatilized by the heat of the furnace, but a large part, still remaining, combines with the copper and a part of the iron, to form the complex sulphide called matte. The iron not needed for the matte, enters the slag. Since the copper-furnace slag may vary within wide limits we use a silicious ore where silica is abundant and a basic one where plenty of iron is present, or in treating basic ores.

CHARGE SHEET. REGULAR MATTE SMELTING.

Name of Ore	Weight		Cu		SiO ₂		Fe and Mn		CaO and MgO		S		
	H ₂ O	Wet	Dry	%	Wt.	%	Wt.	%	Wt.	%	Wt.	%	Wt.
Roasted Ore.....	3.0		1000	10.0	100	25.0	250	30.0	300			10.0	100
Limestone	0		300			4.2	12			52.0	156		
Coke (10%)	0		130			7.2	9	1.2	2	1.8	2		
					100		271		302		158		100
					Cu in Slag = 4		For Matte = 129						25
					Cu in Matte = 96		For Slag = 173		S in Matte =				75
					Cu & Fe " " = 225								3
					Fe " " = 129				Cu and Fe in Matte =				225

Slag.	In the slag.	Matte.
SiO ₂ = 35%	FeO = 173 × $\frac{9}{7}$ = 222	S = 23%
FeO + CaO = 55%	CaO = 158	Cu + Fe = 69%
Other bases = 10%	Actual FeO + CaO = 380	$\frac{Cu + Fe}{S} = \frac{69}{23} = 3$ (factor)
100%	Needed = 425	
	CaO too little = 45	
$\frac{FeO + CaO}{SiO_2} = \frac{55}{35} = 1.57$ (factor) and $271 \times 1.57 = 425$ of FeO + CaO.		

Above is given a charge calculation, in which the problem is to treat a single roasted ore producing a slag of a pre-determined

composition and a matte that will take up the copper that is present. Limestone is the only flux to be used. The charge is of a size to fill the charge-car or buggy in which it is brought to the furnace.

We will adopt 1000 lb. as a weight of the roasted ore, having the composition Cu 10%, SiO₂ 25%, Fe 30%, and roasted so that 10% sulphur remains. This is to be smelted with limestone containing SiO₂ 4% and CaO 52% to produce a slag of SiO₂ 35% and bases (FeO and CaO) 55%, together 90%, leaving 10% to allow for other elements. The slag has been chosen of this composition as one that has been found to work well. The coke has 12% ash that consists of SiO₂ 60%, Fe 10%, and CaO 15%. These figures, calculated to the coke, are SiO₂ 7.2%, Fe 1.2%, and CaO 1.8 per cent.

A metallurgist, accustomed to types of ore, knows with some degree of precision how much flux he needs. Suppose we decide upon 300 lb. flux. For the calculation we enter on the charge-sheet the 1000 lb. ore, the 300 lb. limestone, and 10% of these or 130 lb. coke in the column of dry weight. When the exact figures have been computed, the wet weights may be inserted in the adjoining column, using the figures for per cent given in the column marked H₂O. The percentage of ore, flux, and fuel are then written in the appropriate columns, and the corresponding weights, calculated to the nearest pound, are written in and the totals added.

Beneath, and at the left of the sheet, tabulate the slag composition. Find the ratio of base to silica, which in this case will be 1.57 to 1. On the right of the sheet write the matte composition. We know it will carry 23% sulphur, and roughly 69% copper and iron. Also find the ratio of sulphur to base, which here is 3 to 1, or the factor 3.

Let us first consider the sulphur. Experience shows that in regular matte smelting we can depend upon a loss by volatilization of 20 to 40% sulphur. We take 25% as an average, and thus 75% of the sulphur is left to form matte. This is 75 lb., and multiplied by the factor 3 indicates that 225 lb. Cu and Fe together are needed to satisfy the sulphur.

The slag produced is calculated by dividing the weight by the per cent, expressed decimally, or $271 \div 0.35 = 770$ lb. Allowing 0.5% copper for the slag (and in good work it should not exceed this) the weight so lost is 4 lb., leaving 96 lb. to enter the matte. Subtracting the weight of this copper from the total 225 lb. of copper and iron needed for the matte, we get 129 lb. iron entering the matte, out of the total 302 lb. in the charge. The remainder

(173 lb.) is available for the slag. But the iron existing in the charge as ferric iron is reduced to ferrous form, and we have, in the ratio of atomic weights, 56 parts Fe equal 72 of FeO, or 173 lb. Fe equal 222 lb. FeO. To this we add the 158 lb. CaO, making 380 lb. of the two bases. Multiplying the silica (271 lb.) by the factor 1.57 we find we need 425 lb. of the bases FeO and CaO, so that we have a deficit of 45 lb. Now, since the limestone consists approximately half of CaO, we need to add 90 lb. limestone to the charge, making in all 390 lb. as the required amount. Erase where needed, and re-calculate the charge throughout. This time we should come within a few pounds of the correct amount. As long as it is within 10 lb. it is close enough, since variations in the ores, imperfect weighing, and variation in the amount of sulphur volatilized easily exceeds such differences. When we have learned the actual percentage of volatilization by experience we substitute it for that above assumed. The actual percentage of copper and iron is taken in the same way.

The grade of the matte in copper is learned from the ratio of the sulphur (75 lb.) to the copper (96 lb.) or 23 to 29%. In the same way we compute from the respective weights the percentage of SiO₂, FeO, and CaO, their aggregate being 90 per cent.

The metallurgist seldom can count on the slag and matte coming from the furnace precisely as calculated. There is a little variation due to the causes already mentioned. When the slag from a newly calculated charge comes down, a sample should be taken and a determination made for Cu, SiO₂, FeO, and CaO. It should be possible to make these determinations in two hours and to correct the charge accordingly. As an approximate rule; to increase an ingredient of the charge a given percentage, add to it the fractional part expressed by its ratio to the remainder of the 100%. Thus if analysis gives 33% and we wish to increase it to 35%, then to the $\frac{2}{33}$ of 271 = 16.4 lb. add $\frac{33}{67}$ or $\frac{1}{2}$ of 16.4 lb., making the total silica to be added 25 pounds.

90. PYRITE MATTE SMELTING.

This consists in treating in a blast-furnace, such as that shown in Fig. 131, sulphide ore consisting largely of pyrite and chalcopyrite. The ore carries gold and silver, which are recovered in the copper-bearing matte produced. No preliminary roasting is given the ore, and the smelting is conducted in such a way that 70 to 80% of the sulphur is burned in the furnace while the remainder, uniting with iron and the copper, forms the matte which

acts as collector for the gold and silver. A slag is formed from the silica of the gangue and the bases of the ore and flux. At times when the quantity of base, especially iron, is large it is necessary, in order to make a suitable slag, to add silicious ore. The matte and slag flowing together from the furnace separate in the fore-hearth.

It will be noticed that the slow and expensive preliminary roasting of the sulphide ores is obviated, and that the amount of fuel needed is small ($1\frac{1}{2}$ to 6%) because of the heat developed by the burning of the sulphide. Pyrite or chalcopyrite contains iron that is available both for matte and slag, and when the matte can spare it for the slag the iron serves to flux the silica of iron-free ores on the charge. Iron ore or limestone acts in the same way, and either of them, though generally the latter, may be added for the purpose.

An iron matte alone does not entirely collect the gold and silver from the ore-charge, and it has been found that copper, to the extent of 0.5% or more, should be present to insure the collection of these metals in the matte. The slag then will be nearly free from the precious metals. Copper, therefore, acts as an efficient collector.

In result of burning 70 to 80% of the sulphur of the charge, there remains only 30 to 20% to form matte. The remaining sulphur first takes up copper, for which it has a greater affinity than for iron. It is the burning off of the large amount of sulphur that enables one to dispense with roasting and to diminish the amount of matte produced. The matte produced per ton of ore, or the matte-fall, may be expressed as a percentage, or as a concentration of so many tons into one of matte. Thus, with a production of 200 lb. matte per ton of ore, we have a 10% matte-fall, or a concentration of 10 into 1. It is desirable to concentrate the ore into a small bulk of matte. To show how such concentration is effected, both in regular matte smelting and in pyrite smelting, we enter upon the following considerations:

In regular smelting (with a charge containing 8% sulphur, the volatilization-loss being 25%, and the matte to contain 25% sulphur), we have from 100 lb. ore 75% of 8% = 6 lb. sulphur to form matte. This makes 24 lb. matte and results in a concentration of 4.2 into 1.

In pyrite smelting with a charge containing 30% sulphur, the volatilization loss being 80% and the matte still to contain 25% sulphur, we have from 100 lb of ore 20% of 30% = 6 lb. of sulphur

to form matte. This makes 24 lb. of matte, the same concentration as in the regular matte smelting just specified.

It will be noted that the percentage of volatilization, or the amount of sulphur burned, varies with the charge. It is low when only roasted or oxidized ores are used, and high for raw or inherent in pyrite smelting is the difficulty of regulating this loss. When the furnace, which is burning the right amount of sulphur, begins to run slow from any cause, the volatilization may increase to the point of burning the entire content of sulphur, so that no matte is produced. On the other hand, when the furnace begins to run fast, much matte, low in copper is produced. The principal difficulty in pyrite smelting is the regulation of the matte-fall.

91. REACTIONS IN PYRITE SMELTING.

Let us take the case of smelting with a 12-ft. smelting column. The charge is composed largely of pyrite, with chalcopyrite and a gangue of silica. To this limestone, for flux, has been added, and a small percentage of coke, which, however, does not interfere with the reactions.

At the temperature of the surface of the charge (250°C.) the FeS_2 reacts, and a part of the sulphur escapes. This encountering air entering the feed-door, burns with the characteristic blue flame to SO_2 , while Fe_3S_4 remains. As the temperature becomes higher, unroasted ones, especially those containing pyrite. A defect 5 ft. down from the top, sulphur is expelled, leaving FeS .

Seven feet down, dissociation continuing, we have $\text{Fe}_5\text{S}_4 = 4\text{FeS} + \text{Fe}$ or a condition in which FeS holds Fe in solution, so that, if a sample of the substance in a molten condition were withdrawn from the furnace, we would find Fe separating from the FeS on cooling. The pyrite at this zone (925 to 950°C.) begins to melt, and the descending drops meet the rising air of the blast, and the principal reaction of the furnace takes place as follows:

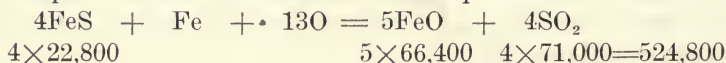

This is equivalent to 1874 pound-calories per pound of iron present.

Generally not all the FeS is oxidized, a part escaping the action of the blast and entering the crucible. Where for any reason the furnace slows down, as for example after the addition of a large amount of silicious material, the air has time to burn the FeS , and little or no matte is formed. In pyrite smelting the degree of concentration depends upon the amount of air blown into the furnace, and the more silica we have in the slag, the greater will

be the concentration. In a well-working furnace 300 lb. air is needed to 1 lb. sulphur, and the silica would approximate 32%. If the concentration is low, we may add silica or quartz, and if high, discontinue feeding it. Considered in another way, the pyrite furnace chooses its own slag.

Below the preparatory zone, FeO and CaO (if present) are transformed into slag, uniting with the silica. The unmelted material keeps the charge open and porous, and the ore column, instead of resting on a bed of burning coke in the crucible, as when coke is used, rests upon a net-work of quartz pieces that have thus far escaped being slagged. The net-work of unfused pieces extends from the crucible upward to the zone of fusion of the iron sulphide, 7 ft. above the tuyeres. At the sides the net-work is moving slowly downward and sustaining the portion that is descending regularly. At 5 to 6 ft. above the tuyeres is found the CO₂, the result of the combustion of the coke near the tuyere-zone.

We may consider that the chalcopyrite loses some sulphur, but is little changed, because of the superior affinity of copper for sulphur as compared with iron, and in consequence it melts, forms matte, falls in drops to the crucible, and at the same time seeks and collects the gold and silver of the charge.

92. PYRITE SMELTING IN TWO STAGES.

For low-grade ores, carrying 2% copper for example, a concentration of ten into one gives matte of 20% copper. By roasting the matte, or by smelting it pyritically, it is possible to increase the grade to 40% or more, and this product can be treated in the copper-converter and brought to the grade of blister copper. An ore containing 5% copper can be smelted to give a matte of 40% copper, so that the second smelting with the additional expense can be omitted. Now while it would not pay to smelt a copper ore of a grade as low as 2% copper, for the copper alone, if the ore contained gold and silver the recovery of these metals would justify the expense of smelting.

Two-stage smelting at Ducktown, Tennessee.—At the works of the Tennessee Copper Co., the process is a two-stage one, the ore being smelted to give matte of 10% Cu ('ore-smelting'), this matte being re-treated in another furnace to produce a 35 to 45% matte ('matte-smelting'). The slag from the second furnace, not yet sufficiently clean to throw away, is re-melted in the first furnace. The second matte is then converted to blister copper of 88 per cent.

The furnaces (of the type shown in Fig. 131), are 180 in. long

by 56 in. wide at the tuyere level, and have large circular fore-hearths, 16 ft. outside diameter by 5 ft. deep, lined with chromite brick to resist the corrosive action of the low-grade matte produced. The first, or ore-furnace, treats 400 tons of charge daily, with a coke-consumption of 2.1%. The second or concentration furnace smelts 280 to 300 tons of matte, using 3.5% coke. The following charge-sheet gives details regarding the charge and the matte produced in both the stages, and shows how such charges are computed in pyrite smelting.

93. CALCULATION OF CHARGE IN PYRITE SMELTING.

In these calculations the quantity of coke is so small that no computation is required for the ash. The quantity of base in the ore is so large, and the silica is so low that it has been necessary to add silicious material (in this case quartz-rock) to the charge in order to obtain a slag of 35% silica. The problem is to compute the amount of quartz to be added to give such a slag.

CHARGE SHEET I. ORE-SMELTING FURNACE.

Name of Ore	Weight		H ₂ O	Cu		SiO ₂		Fe + Mn		CaO + MgO		S	
	Wet	Dry		%	lb.	%	lb.	%	lb.	%	lb.	%	lb.
Polk Co.		1000		2.4	24	20.7	207	34.2	342	9.2	92	20.4	204
Burra-Burra		3000		2.1	63	9.4	282	38.0	1140	8.3	249	30.3	909
Quartz		700				97.0	679						
Coke	100				87		1168		1482		341		1113
		Cu in Slag			6					Volatilized=890			
		" " Matte			81					In Slag = 43 933			
										Matte = 180			

$$\begin{aligned}
 & \text{Slag.} \\
 & \text{FeO} + \text{SiO}_2 = 35.0\% \\
 & \text{CaO} = 55.0\% \\
 & \text{S} = 1.3\% \\
 & \text{Cu} = 0.2\% \\
 & \text{Slag} = 1168 \div 0.35 = 3300 \\
 & \text{Factor} = \frac{35}{55} = 0.636
 \end{aligned}$$

$$\begin{aligned}
 & \text{Matte.} \\
 & \text{Fe} + \text{Cu} = 65\% \\
 & \text{S} = 25\% \\
 & \frac{\text{Cu} + \text{Fe}}{\text{S}} = 2.6
 \end{aligned}$$

We represent on the charge-sheet the ores that are to be run, using amounts in accord with the rate at which the respective ores are supplied (1000 lb. Polk county ore and 3000 lb. Burra-Burra ore). Experience shows that for such a charge and for the quantity of ferrous iron and lime present, we may enter the quantity of silicious material as 700 lb. We use a slag of 35% SiO₂ and 55% FeO and CaO, making in all 90%. With this slag, experience shows

we may figure on 1.3% sulphur and 0.2% copper for this low-grade matte. A little zinc, when that element is present in the charge, also enters the slag. This is shown to be 0.3 per cent.

The matte is assumed to contain 25% sulphur, 65% copper and iron, and 1.7% zinc. We estimate that 80% of the zinc will be volatilized. It is understood that in smelting other ores than these, the actual quantities of the different elements in the matte and slag will be determined and those figures substituted for the ones above.

The percentage of ingredients of the charge is written and carried out in the respective columns, and the columns are added.

Beginning with the sulphur, of the 1113 lb. present, we have:

	Pounds.
Sulphur volatilized (80% of the total) =	890
“ in the slag (1.3% of 3300 lb.) =	43
“ left for the matte =	180
	1113

Of the copper, 0.2% of 3300 lb. or 6 lb. goes into the slag, leaving 81 lb. for the matte. Multiplying the sulphur for the matte, 180 lb., by the factor 2.6 we get the total Fe and Cu needed for matte, 468 lb.; subtracting Cu for matte, 81 lb.; leaves Fe for matte, 387 pounds.

But the total iron in the charge is 1482 lb., so that we have:

	Pounds.
Fe in matte.....	387
Fe left for slag.....	1095
	1482

The iron in the slag occurs as FeO, so that we must take 1408 lb. FeO, equivalent to the 1095 lb. Fe. Adding to this the CaO, 341 lb., we get FeO + CaO = 1749 lb., which multiplied by the factor 0.636, gives SiO₂ = 1112 lb.

	Pounds.
Actual silica in charge.....	1168
Silica needed.....	1112
	56

By erasing the trial amount 700 lb. of quartz, and substituting 650 lb., then re-calculating the charge, we get an approximation within 10 to 20 lb., which is accurate enough for practical purposes.

The percentage of copper in the matte is computed according to the proportions 195:81:25%:10.4 per cent.

94. CALCULATION OF MATTE CHARGE.

The matte charge is run with slag from the converting operation, and quartz ore in sufficient quantity to produce a slag of the same composition as that of the ore-charge, except that it has 1% sulphur and 0.7% copper.

CHARGE-SHEET II. MATTE-CONCENTRATING FURNACE.

Name of Ore	Weights		H ₂ O	Cu		SiO ₂		Fe + Mn		CaO + MnO		S	
	Wet	Dry		%	lb.	%	lb.	%	lb.	%	lb.	%	lb.
Matte.....		3000		10.0	300			55.0	1650			25.0	750
Quartz.....		1400				97.0	1358						
Limestone.....		200				4.0	8			53.0	106		
Convert. Slag.....		400		2.0	8	30.0	120	55.0	220	1.0	4	1.0	4
Coke.....	100												
					<u>308</u>		<u>1486</u>		<u>1870</u>		<u>110</u>		<u>754</u>
				Cu in Slag = <u>30</u>						Volatilized 530			
				" " Matte = <u>278</u>						In Slag		<u>43</u>	<u>573</u>
													181

Slag.
 SiO₂ = 35.0%
 FeO + CaO = 55.0%
 S = 1.0%
 Cu = 0.7%
 Slag = 1486 + 0.35 = 4300 lb.
 Factor $\frac{35}{55} = 0.636$

Matte.
 Fe + Cu = 65%
 S = 25%
 $\frac{Cu + Fe}{S} = 2.6$

The charge is estimated as in 'Charge-sheet I', with a volatilization of 70% of the sulphur, as experience has shown the result commonly to be. In the matte we have:

	Pounds.
S	181 = 25.0
Cu	278 = 38.4
(181 × 2.6) - 278 = Fe.....	193 = 26.6
	<u>652 = 90.0</u>

Proceeding with the calculation for the quartz we have:

	Pounds.
Total iron.....	1870
Iron in matte.....	193
Iron for slag.....	<u>1677</u>

or FeO = 2156, and the total base is 2266 lb.

This gives the silica needed, $2266 \times 0.636 = 1509$ lb. But we have already 1486 lb., and the difference may be made up by increasing the quartz 20 pounds.

95. MATTE CONCENTRATION.

In an example above, we obtained a matte 10% in copper, and with copper low in the charge, the percentage may be even less. The matte is of too low grade to ship away, or to bring to the grade of blister-copper in a converter. It must be concentrated to one of higher grade. If we were to heap-roast the matte and then smelt it with silicious ore in a blast-furnace, we should obtain a small quantity of matte of a high grade.

There is, however, the expense and delay of the roasting to consider, and it has been sought to smelt the matte raw, with silicious ore, with the idea of burning off the sulphur in the blast-furnace. In regular matte-smelting, were this attempted, the matte would run, though little diminished in quantity and little changed in grade, but by the new method, using little fuel, an abundant blast, and silicious slag, the concentration can be obtained.

If the matte is to be transported for treatment it should be at least 50% copper. If of 40%, however, it can be treated in the converter to bring it up to the grade of blister copper. Where it is difficult even with two-stage smelting to bring the matte to this concentration, a lower-grade matte may be made and shipped away for treatment elsewhere.

96. SLAG DISPOSAL.

The slag from a blast-furnace, being a waste material, is disposed of in the cheapest way possible. In the case of small furnaces, as it flows from the fore-hearth, it is caught in wheeled slag-pots (slag carts), Fig. 135, that are taken to the edge of the slag-dump when filled and poured. As the dump grows the expense increases, and large slag cars, Fig. 137, are used. The cars are moved either by horses, or an industrial locomotive, or by trolley.

Another cheap and favorite way is to granulate the slag. To do this a cast-iron launder is arranged to receive the slag as it falls from the spout of the fore-hearth. The launder has a grade of 1 in. to the foot, and through it water is made to flow constantly. In addition, a horizontal flattened jet of water strikes the falling slag, instantly cooling and breaking it into granules of various

sizes averaging one-sixteenth of an inch in diameter. The flow of water carries the slag to the dump.

97. REVERBERATORY MATTE-SMELTING.

While the blast-furnace in general is the cheapest means of smelting copper-bearing ores in coarse or lump form, one objection to it is that the strong blast necessarily used may carry away 5

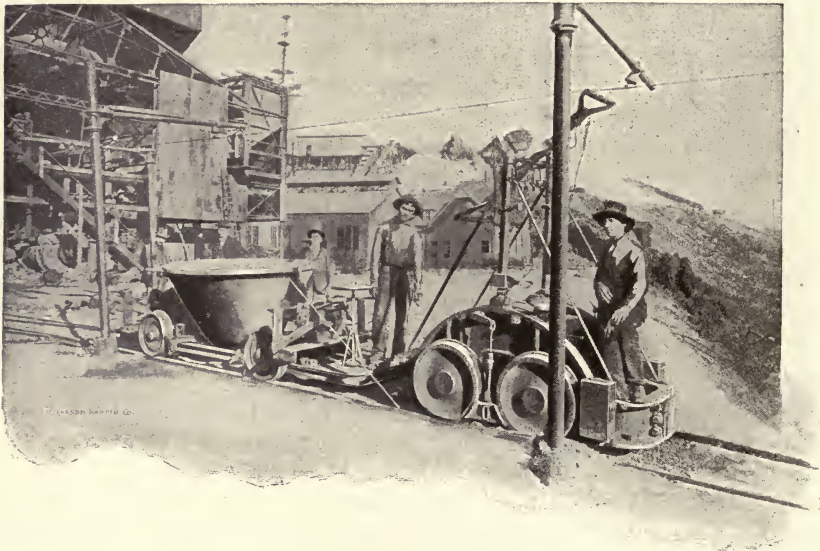

Fig. 137. ELECTRIC TROLLEY SYSTEM.

to 10% of the fine dusty ore. Such ore may be settled as flue-dust, in flues and dust-chambers, and made into briquettes and re-smelted, but this is an additional expense to be avoided if possible. In fact, ore or concentrate, in fine condition, is better treated in reverberatory furnaces. When putting the charge into the furnace the stack-damper is closed, and when the dust from the dropping ore had subsided it is again opened. The ore is not then disturbed. If raw sulphide were melted in such a furnace, no sulphur would be expelled; hence before such treatment, sulphide ore must be roasted, generally in one of the types of mechanical roasters. The output of a reverberatory is much less than that of a blast-furnace, and a larger proportion of fuel is needed, though it may be of a cheaper kind. Thus we use in reverberatory smelting, 30% of bituminous coal as against 10% of coke in regular blast-furnace smelting, or as little as 1.5 to 6% in pyrite smelting. We may

say, as far as fuel is concerned, that the 30% fuel at \$2.50 per ton would balance the 10% coke at \$7.50 per ton.

98. THE REVERBERATORY MATTING-FURNACE.

Fig. 138 represents an elevation and Fig. 139 a sectional plan of a large reverberatory matting-furnace, having a hearth 37.5 ft. long by 15 ft. wide with a fire-box 7 by 8 ft., or of 56 sq. ft. area. Over the furnace are six hoppers for charging the ore, and one double hopper from which coal is charged as needed, to the fire-box. The front of the furnace is the flue-end; the back is the fire-box end. The larger portion of the charge is fed near the latter, the hotter part of the furnace. The interior line of the furnace is shown by dotted lines in the elevation that shows also the fire-box, the bridge or wall separating the hearth from the fire-box; the hearth, and outlet-flue. As shown in the plan, the bridge is furnished with a double cast-iron plate, called 'conker plate.' This serves to support and strengthen the bridge. There are two doors at either side of the furnace by which access is had for repairs, but these commonly are kept tightly closed. At the side near the middle is noticed the side skimming-doors. Slag is skimmed also from the surface of the molten charge at the front-end, through a door 12 in. above the hearth-bottom.

At the back of the furnace, between the two doors, is noticed the matte tap-hole. It is set low to drain the furnace of the entire content when required. By means of it the matte is withdrawn after the supernatant slag has been skimmed from the charge.

At the height of the hearth-bottom are the grate-bars, and below them the ash-pit, 5 ft. deep. The fire is 'grated' or cleaned twice in 24 hours. The doors of the ash-pit are opened and men enter to remove the ashes and clinkers from the grate, using a long, stout, steel bar for the purpose. The material falls into a low car on a track shown in plan, Fig. 139. The fire having been grated, the car is removed, the ash-pit doors are closed and tightly luted with clay, and air from a fan-blower is admitted from a pipe (shown in the plan) to the ash-pit. This gives an under-grate pressure, burns the coal rapidly, and decreases the necessary stack-draft and the consequent sucking of cold air into the furnace. The stack is separate from the furnace, the smoke entering by a sloping flue.

Operation of the furnace.—While a blast-furnace is fed with successive charges, the reverberatory receives a charge of many tons at one time. The roasted ore for the reverberatory is stored in the hoppers above the furnace, and drops into the furnace when

65'
high

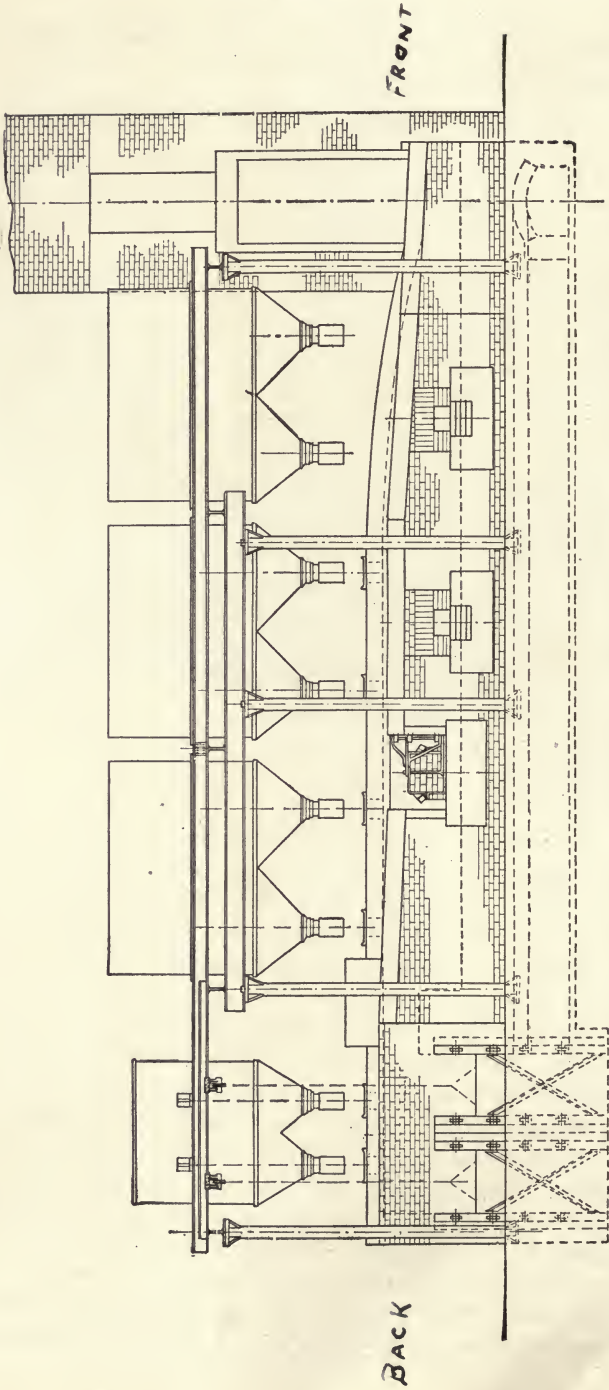

Fig. 138. REVERBERATORY SMELTING FURNACE (ELEVATION).

the charge-opening is uncovered and the hopper-slide withdrawn. If the ore were to drop directly upon the hearth the cold charge

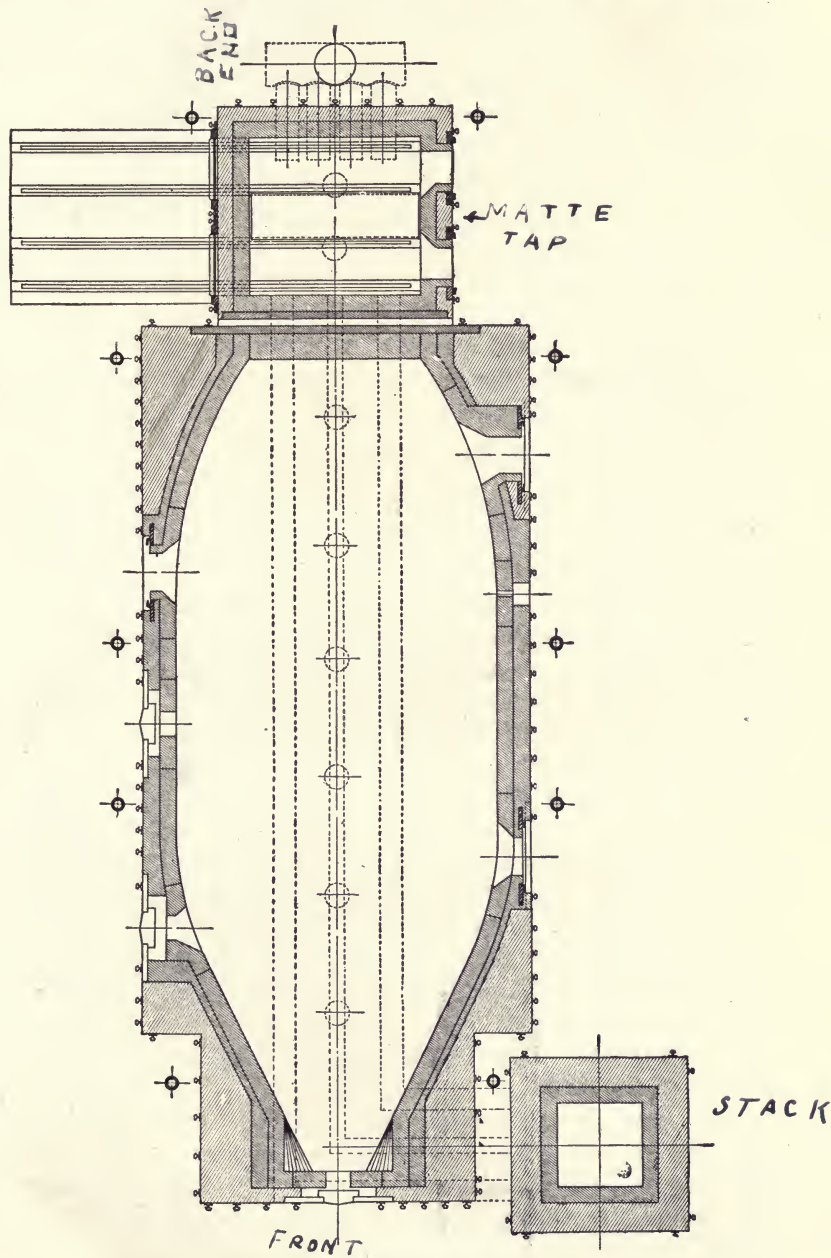

Fig. 139. REVERBERATORY SMELTING FURNACE (PLAN).

Note:— In order to correspond with the elevation

would adhere to it and would be slow to heat and melt. It is customary to retain a pool of matte in the furnace upon which the ore drops and floats out. At the time of charging, the fire is cleaned or grated. Firing now proceeds vigorously until the charge is melted. This work takes several hours.

The sulphur of the charge unites with the copper and iron until its needs are satisfied. The matte thus formed, separating in drops, absorbs the precious metals contained in the ore, and by the greater specific gravity than that of the slag, penetrates downward to the hearth. The silica of the gangue unites with base, such as FeO, CaO, and Al₂O₃, and forms a fusible slag that floats as a separate layer upon the matte.

When ore is roasted a part of the iron is oxidized to the ferric state, and when the charge is fused the ferric iron acts upon the unroasted ferrous sulphide according to the following equation:



When ferric iron is present in the ore, sulphur is eliminated often to the extent of 25 to 33%, and we find less matte than would be present if this reaction did not take place. The iron, thus reduced to ferrous form, enters the slag.

The skimming-doors, one or both, are opened, and the slag is skimmed off by means of long-handled rabbles. As the slag is removed it falls into slag-carts that are wheeled away to the dump. The side-doors of the furnace are now opened, and the interior walls repaired, especially at the bridge end of the furnace where they have been eaten out by the action of the molten slag. The repair-work or fettling is done by skilfully throwing sand from the side-door across the furnace so that it banks up against the opposite wall. The repair is also made by placing the sand upon the desired spot by means of a long-handled paddle or spoon. Balls of ganister are brought to the spot and pressed against the side by the same tool. The side-doors are now closed and luted tightly with a clay mortar, and the charge, already in the hopper, is put into the furnace. The operation cools the furnace as does also the grating of the fires.

The matte, when tapped, runs into sand-molds or depressions made in the sand-floor of the furnace-house. Another way of handling is to draw the matte into ladles that are operated by an overhead traveling crane, by means of which it is transferred to the converter.

99. REVERBERATORY SMELTING (WELSH PROCESS).

The process consists in treating copper ore (sulphide and oxide as well as silicious ore) by a series of roastings and fusions to raise the grade of the copper finally to blister copper, which subsequently is refined. It possesses the advantage that a variety of ores both coarse and fine can be treated in a few reverberatory furnaces without large investment in plant. For a small tonnage, it is possible to produce on the spot metallic copper.

We may divide the process into five operations:

(1) 'Calcining' the ore: Sulphide ore containing 5 to 15% copper is roasted in a hand-reverberatory roaster (See Fig. 31 and 32) until not more than 5% sulphur is left.

(2) Fusion of ore: The roasted ore is charged in a reverberatory furnace with such oxidized copper ore as is available, and melted. The sulphur contained in the roasted ore, with the copper and some of the iron, forms a matte of 35% copper, called 'coarse metal.' The silica, uniting with the ferrous-oxide not taken by the matte, and also with the alumina, and the alkaline-earth bases, forms a slag, fusible at the high temperature of the furnace. The molten bath boils from the escape of sulphur oxides resulting from the reaction of the ferric iron upon unroasted ferrous sulphide, or from the decomposition of barium, lead, or zinc sulphide by silica, thus:

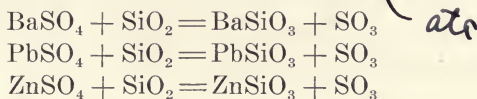

The sulphuric anhydride escapes as a gas, and upon meeting the moisture of the air at the top of the stack, changes to a white fume of H_2SO_4 .

(3) Calcining coarse-metal: The coarse metal or matte that is run from the reverberatory furnace in operation (2) into sand beds, is crushed to pass a 5-mesh screen and fed to another hand-roaster. Rich sulphide of 20 to 70% copper also is crushed and added to the charge. The whole is roasted until it contains not more than 5% sulphur.

(4) Second reverberatory fusion: The roasted material, now of 35 to 50% copper, is charged into a fusion-furnace with oxidized ores containing 20 to 70% copper. When the charge is melted there results a matte of 75% copper, called 'white metal,' composed chiefly of copper sulphide. As before, the silica contained in the ore added to the charge unites with the ferrous iron and other bases to form slag. This slag, however, having been made from such

rich material, contains much copper and is not to be thrown away but returned to another charge in the fusion furnace of operation (2).

(5) 'Roasting' and formation of blister copper: The white metal is charged in large pieces, as broken when removing from the sand molds, into a reverberatory fusion-furnace where it is piled in an open fashion particularly near the bridge. It is fired gradually several hours with an oxidizing flame. A small supply of air is admitted at a number of ports or openings 2.5 in. sq. in the roof over the fire-bridge, and at the sides of the furnace near the bridge. The operation is called 'roasting.' The oxidizing flame, acting at the surface of the lumps and upon the drops trickling down, converts a portion into cuprous oxide, so that we have present copper both as sulphide and as oxide. Finally the heat is raised and the whole charge is melted down. Now occurs the endothermic reaction:

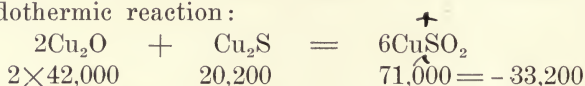

Copious fumes of SO_2 issue from the boiling surface of the molten charge. Slag rich in copper is produced, getting the silica partly from the interior walls of the furnace, partly from silicious but entirely oxidized ore that has been added to supply silica. The slag is returned to operation (4). Finally the blister-copper is tapped. The metal obtains this name from the fact that, upon cooling, occluded gas seeking to escape from the molten metal, forms blisters on the surface of the pigs of metal.

The blister-copper now contains 98% copper, but also impurities that must be removed to make it suitable for market. The refining process is described elsewhere. In case the copper contains gold and silver, taken from the ores that supplied the copper, it is customary to re-melt it, pole it to remove copper oxide, and to cast it into anodes for electrolytic refining.

100. BEST-SELECTED COPPER.

Where copper ores are impure, and at the same time where it is desired to obtain a superior grade of refined copper, the Welsh process is modified as follows:

A portion of the white-metal, produced in operation (4) is ground to 5-mesh and roasted or calcined so that part of the Cu_2S is oxidized to Cu_2O . This roasted matte is put into a fusion-furnace and melted down quickly with a large proportion of white-metal in lump form. A reaction occurs between the Cu_2O present and

some of the Cu_2S , and a small part of the charge (one-fifteenth of the whole) is reduced to metal. The metal takes the impurities of the charge such as arsenic, antimony, and tellurium, and also the gold if present, while the unreduced matte, freed from these impurities, is pure. After skimming the charge the content of the furnace is tapped into sand-molds. In the first few molds is found a layer of copper that has been produced. It lies beneath the matte that forms most of the pig and is called 'bottoms.' The pure matte thus obtained is treated as in process (5), and a blister-copper, comparatively free from impurities, is obtained.

Treatment of the bottoms.—The impure bottoms are re-melted and cast into anodes for electrolytic refining, in which the impurities and gold are separated from the copper; or they may be formed into an inferior grade of copper (casting copper) as follows: A charge is put into the blister-furnace as in operation (5), consisting of 14,000 lb. of 75% roasted white-metal, 21,000 lb. raw white-metal, 8000 lb. bottoms, and 1000 lb. silicious ore. This is melted down, and then is added 6000 lb. more roasted white-metal. The charge aggregates 50,000 lb. This is treated precisely like the regular blister charge, but it yields a higher percentage of copper.

101. THE DIRECT PROCESS.

This is a modification from the Welsh method of producing blister copper. Instead of 'roasting' the matte or white-metal in lump form in the blister-furnace or process (5), a portion is ground to 5-mesh size and calcined or roasted in a separate roasting-furnace, of either the hand or the mechanical type.

Into a melting furnace, called the 'blister-furnace,' is charged 14,000 lb. of the roasted white metal, still retaining 4 to 6% sulphur, 3500 lb. raw unroasted white metal, 4000 to 8000 lb. slag from a former charge, and 600 lb. silicious ore to unite with the FeO and other base present. When this has been melted, 6000 lb. more roasted matte is added, making a total of 23,500 lb. matte charged. When all is fused, the reaction begins. The surface of the charge is seen to be seething and boiling, and escaping bubbles of gas are set free according to the following reaction:

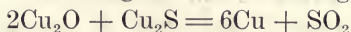

The bath is then skimmed to remove the slag, which contains copper oxide, reserved in part for the next charge and in part sent back to stage (4) of the Welsh process. From the charge here specified there is produced 75 pigs weighing 230 lb. each, or 17,250 lb. blister copper, and, also, 23 pots of slag weighing 400 lb. or 9200 lb. containing 12 to 15% copper.

102. REVERBERTORY MATTE-SMELTING AT ANACONDA, MONTANA.

There are eight reverberatory melting-furnaces at this plant, that are intended for the production of a matte of 40% copper from roasted concentrate. The matte is treated in converters. Fig. 140 and 141 represent, in elevation and plan respectively, one of the reverberatory melting-furnaces at the Washoe plant of the Anaconda Copper Mining Co. Two boilers are heated by the waste gas from the furnace, and develop, together, 600 hp. The furnace treats, on an average, 275 tons in 24 hours, producing a 40% matte with a concentration of 4 into 1.

The charge consists of hot roasted ore ('calcines') from the McDougall roasters, Fig. 43, and by analysis is shown to be composed as follows: Cu 9%, FeO 24.4%, CaO 2.9%, S 8%, SiO₂ 26%. Every 80 minutes a charge of 15 tons is dropped into the furnace from the two hoppers (shown by full lines in the elevation) near the fire-bridge. This falls upon the bath of molten matte and slag that the furnace contains. It spreads in all directions, and much of it floats gradually toward the front. It readily melts by contact with the molten slag and matte below and the flame above. In this great reservoir of heat there is but little variation in temperature, and the flame is transparent.

The fuel is soft coal, 21% of the charge or 56 tons daily, upon 110.7 sq. ft. of grate surface, or 40 lb. per sq. ft. per hour. Every four hours 45 to 50 tons of slag is removed in 15 minutes from the furnace and allowed to flow from the front door in a thick stream. It is granulated by a strong horizontal stream of water as it falls into the waste-laundry. The water sweeps it away to the dump several hundred yards from the furnace. The matte is kept at a nearly uniform level, ten tons being tapped out at a time, while the total amount in the furnace is 100 to 150 tons.

The action of the slag upon the furnace is to erode or scour it, but because of the width, the sides are less acted upon than would be the case in a narrow furnace. To repair the furnace, as is done monthly, both slag and matte are drawn off completely, then the side-doors are opened, and sand is thrown against the sides where eaten away by the slag. They thus are protected against the inroads of the slag. A furnace runs six or eight months and then has to be shut down for the thorough repair of the roof, walls, and bridge. These parts are of silica brick, the walls being 30 in. thick, the roof 15 in. Silica bricks are practically infusible but expand

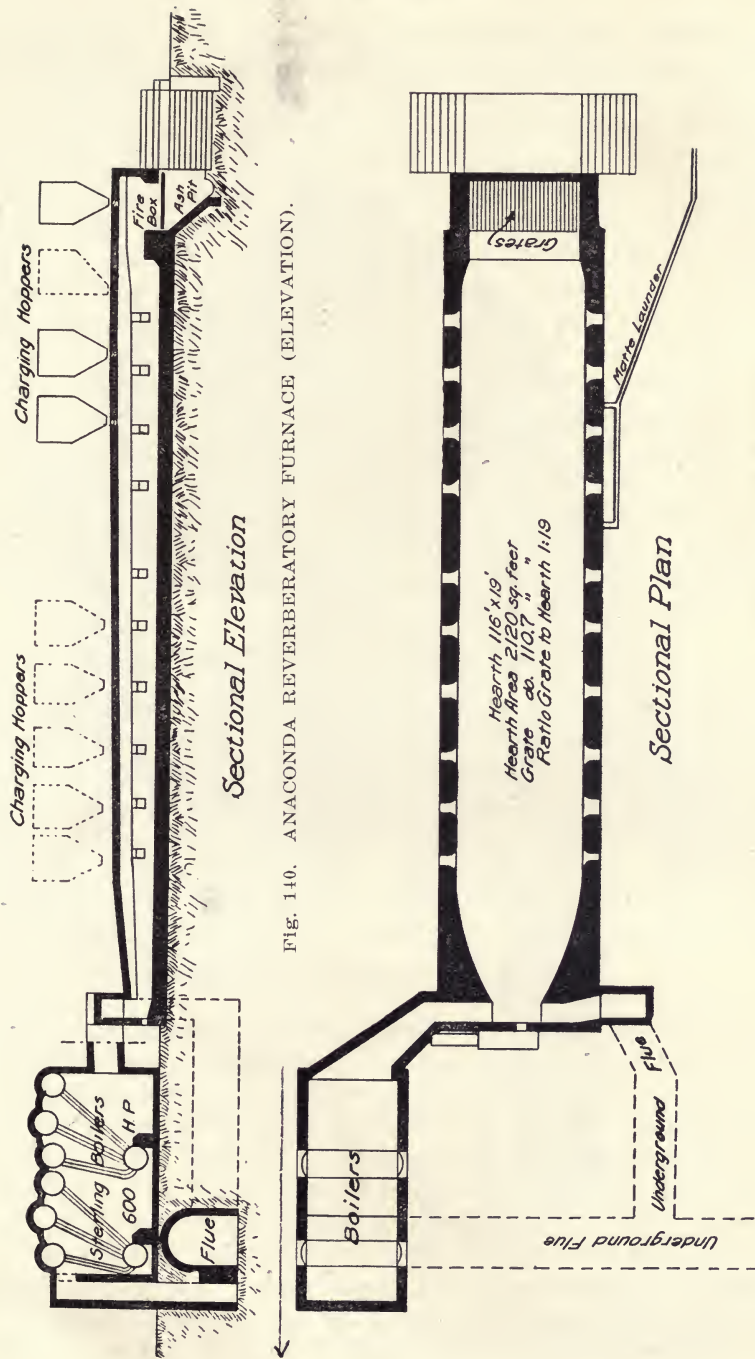

FIG. 140. ANACONDA REVERBERATORY FURNACE (ELEVATION).

FIG. 141. ANACONDA REVERBERATORY FURNACE (PLAN).

on heating, so that allowance is made by leaving transverse slits in the roof. These close when the furnace is at full heat. An important point in efficient working is to have the outlet-flue, or 'neck,' of the proper size. It must be large to insure good draft, and yet retain the flame in the furnace. In the furnace shown it is 60 by 38 in. or 16 sq. ft. area. The ash-pit slopes steeply at the back to the ash-laundry which carries a constant liberal stream of water. The ash and cinder fall into the laundry and are at once carried away. Hence the ash-pit is always cool and accessible, and the fire is kept constantly clean and effectually grated. About 10% of the fuel drops as unburned coke with the ashes, and is carried by the laundry to a concentrating room where the coke is removed, and, since it still retains heat-value, is ground with flue-dust and fine ore and made into briquettes that are fed to the blast-furnaces. When the Sterling boilers that utilize the waste-heat are to be repaired, they are shut off by damper, and the furnace gas is turned into a by-pass flue that leads directly to the main underground-flue to the main stack. The draft pressure equals $1\frac{1}{2}$ to 2 in. of water.

103. CONVERTING COPPER MATTE.

This consists in treating molten matte in a receptacle lined with refractory material, called a converter, by blowing through it compressed air which burns the sulphur of the matte leaving molten blister-copper that is poured from the converter into molds. In making steel from molten pig-iron the same process is used but the upright converter (See Fig. 184), is employed. In treating copper matte the barrel converter (Fig. 142), which revolves about a horizontal axis, is used.

104. THE COPPER CONVERTER.

Fig. 142 is a view of a converter. The arrangement and position of two of these upon the floor of the converter-house is shown in Fig. 143 and 144. In Fig. 142 we see the cylindrical shell and the mechanism by which it is rotated, the floor being broken away to show the hydraulic operating-cylinder. The shell, 84 in. diam. by 126 in. long, and $\frac{5}{8}$ to 1 in. thick, is made of the plate-steel in two sections, so that the top half, parting at the level of the top of the end spur-gear, can be lifted off, leaving the lower portion accessible for re-lining with ganister (refractory silicious lining-material). At the side (not shown in Fig. 142) is bolted the cast-iron wind-box which is of the length of the shell and is fitted with

14 tuyeres, each 1 in. diam. To one head of the shell is bolted a cast-steel open gear-wheel that engages the upright steel-toothed rack connected to the piston of the hydraulic cylinder operated under a pressure of 300 lb. per sq. in. By the movement of this

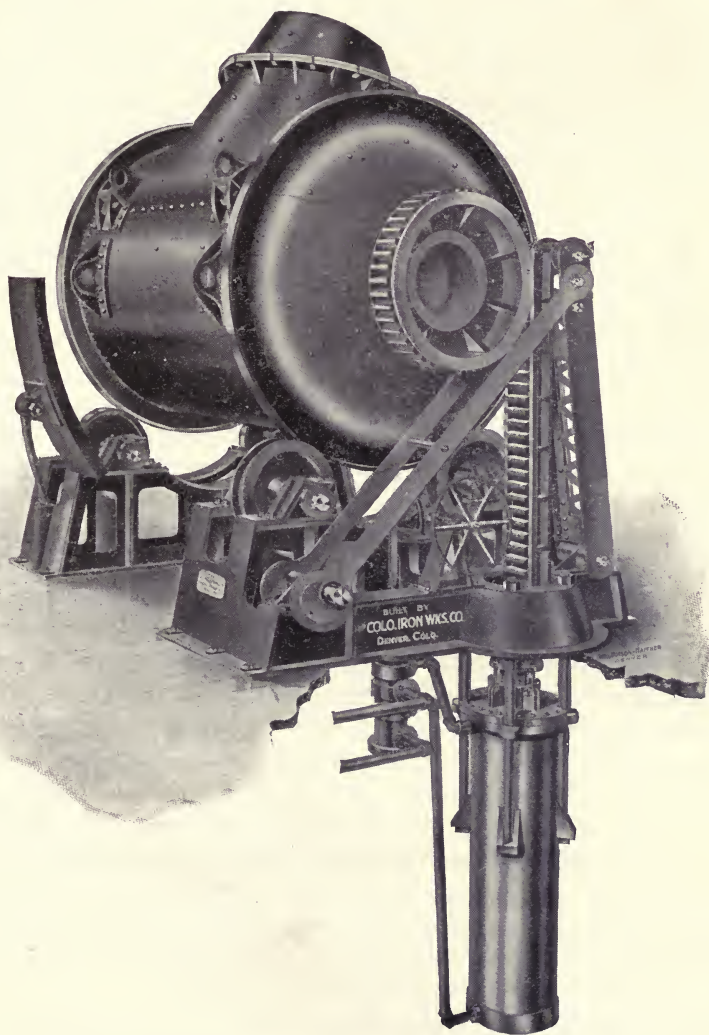

Fig. 142. COPPER CONVERTER.

piston and rack the shell is tilted into any desired position, for receiving the matte or for pouring out slag or copper. Riding rings made of heavy steel rails are bolted to the shell, so that the

weight is borne by the four friction rollers on which it revolves. The friction rollers are carried by heavy cast-iron base-frames. Two inclined tie-links will be noticed at the front of Fig. 142, which hold the rack meshed in gear. When the shell is to be removed for re-lining, the rack, which is joined at the head of the piston rod, is swung back by an eccentric at the foot of the tie-links so that the teeth will clear those of the spur-gear. The shell is lifted by means of a 40-ton traveling crane such as is in the converter building, Fig. 143. In Fig. 142, close to the top of the cylinder, is a four-way valve controlled by a hand-wheel which serves to tilt or revolve the converter. There are four eyes riveted to the converter top to which a four-fold lifting chain is attached, and by which the top can be removed from the main part of the shell. There are also four eyes riveted to the main part, by which the shell can be handled.

105. OPERATION OF CONVERTING.

A converter stand with the shell is constantly in use, and when the lining of one shell is consumed the converter is removed and replaced by a newly lined one. After lining, the converter is prepared as follows. Standing upon the lining-floor at the end of the converter building (See Fig. 144), it is dried. The interior then is brought to a low-red heat by means of a wood fire, followed by one of coke, urged by a blast admitted at the tuyeres. A converter of the barrel type of the size above specified lined at least 12 in. thick with ganister, takes as the initial double-charge 5 tons, and as a final double charge, just before it has to be re-lined, 12 tons of matte.

A charge for a converter is tapped from a reverberatory furnace, or from the fore-hearth or settler of a blast-furnace, into a steel ladle handled by an electric traveling crane (See Fig. 143). The converter is rotated to bring the spout from beneath the hood (shown above it in the illustration) into pouring position, the molten matte is tipped in from the ladle, and the converter is returned to the blowing position, in which it appears in the figure, the pressure of blast being meanwhile applied.

The first blow.—The first blow, or the slag-forming stage of the process, begins when the converter has received the charge of molten matte. A 50% matte would have a composition as follows; Cu 50%, Fe 20%, S 24%, corresponding to Cu_2S and FeS , with a little Fe_3O_4 . The Fe_3O_4 and the Cu_2S are but slightly affected during this blow, the first entering the slag, the second the matte. The

air acts with increasing energy upon the FeS, burning both the iron and sulphur as shown by the following reaction:

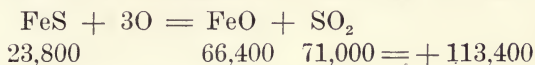

This is an energetic exothermic reaction which, in spite of the volume of air blown in, sustains and even raises the temperature of the molten matte. The SO₂ passes off in the escaping gas, and the FeO, with other bases, takes silica from the lining, which accordingly is rapidly eroded. The reaction is at first slow, but it rapidly increases so that at the end of about 45 minutes the iron sulphide is burned and the iron slagged. The end of the stage is determined by the appearance of the issuing flame, the first greenish border of which during the blow changes to a pale permanent blue as the iron oxidizes. Pieces of matte are thrown into the converter, and by their oxidation make the charge hotter. If too hot, sweepings from about the converter that are rich in copper are added and serve to cool it. The slag, formed in result of the addition, increases the total volume. The converter vessel is now turned into pouring position, the blast being shut off, and the slag is poured into a steel ladle on the floor placed to receive it. As the slag flows from the converter 'the skimmer' passes a rabble through it from time to time. He can tell when the matte begins to escape, and signals for the vessel to be returned to blowing position, whereupon the blast is turned on for the second blow. The slag from the first blow, containing 1.5 to 2% copper and about 0.5 to 1 oz. silver per ton, is sent back to the blast-furnace and smelted to extract the remaining silver and copper.

The second blow.—At the beginning of this blow there is little iron left, and the copper has been brought to the stage of white-metal of 75% copper. In this stage the oxidation of the sulphur retained by the copper proceeds, so that we have:

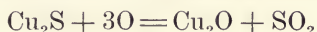

The Cu₂S thus formed, reacts on the CuS not then burned and produces copper with the escape of SO₂ gas as follows:

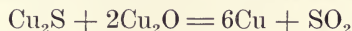

So far as the agitation by the blast permits, the molten content of the vessel separates in layers. An increasing layer of copper is at the bottom, a decreasing layer of matte is above it and slag is on the top. The blast, entering horizontally at the side, 6 to 12 in. above the bottom blows through the matte that is floating above the copper that has formed.

Under normal conditions the escaping flame is of white gradually changing to a rose-red and finally to a brownish red. It decreases in length and volume until, at the last, only a brick-red flickering is to be seen in the escaping gas. The determination of the completion of the operation requires care and experience. If carried too far, over-blown copper results.

As soon as the content of the vessel has been changed to copper, the converter is turned down into pouring position, the blast being at the same time shut off. The copper is poured into molds that are arranged on the carriage which runs on a bullion track beneath the converter. The molds hold 250 to 300 lb. of copper each, and there may be two carriages, each carrying 15 to 20 molds. The converter is turned back into receiving position and the next charge is promptly supplied.

The first charge of a newly lined converter is necessarily small, but, as the lining becomes eaten out, the capacity becomes greater for succeeding charges. In converting matte of 50% copper the process as above outlined is simple, but for low-grade matte of 35 to 40% copper, the method is modified by 'doubling', as it is called. Thus into a newly lined converter a charge of 2 tons of matte is introduced. This is blown to white-metal in the first stage. The converter is turned down, the slag is poured off, and, upon tilting the converter to the receiving position, 3 tons more matte is added, making a double charge of 5 tons in all. This is blown, the slag removed, and with another blow it is finished to blister copper. The advantage of the process lies in the fact that the output is increased, and that the white-metal and blister copper fill the converter and make a sufficient quantity of blister copper for pouring.

The final charge is 12 tons, and since large charges are most profitable, there is a temptation to press operations to the limit. Toward the last, the lining becomes dangerously thin, showing a red-hot area on the shell. Sometimes the place can be kept cool by a stream of water from a hose and the charge can be finished, but if not, it is poured into a ladle and transferred to another converter.

The time taken for converting copper matte averages 40 to 50 minutes for the first, and 50 minutes for the second blow. For charging, skimming, and poling 20 minutes are needed, so we may say that it takes 2 hours for the cycle of operations finishing a charge. A first charge takes little more than an hour, and a final charge more than two hours.

A converter lasts, before re-lining, from 5 to 9 charges, according

to the grade of the matte and the durability of the lining. Low-grade matte, which contains relatively much iron sulphide, corrodes the lining rapidly. The blast pressure varies from 10 to 15 lb. to the square inch.

106. RE-LINING CONVERTERS.

When a converter has become exhausted it is removed from the stand and taken by the crane to the lining floor. The top is unbolted and removed exposing the interior. In the old way, the interior of the vessel was cooled with a stream of water from a hose. The objection to the method is that the water, taking copper salts into solution, has a corrosive action on the rails beneath the converter that frequently have been wet by water spilled or escaping containing copper in solution. In the new way, a large supply of extra shells is provided, so that more time can be taken for cooling. The lower section or body, laid on the side by means of the crane, is cleaned from adhering matte and slag to give the new lining clean surface upon which to adhere. The body is then set upright and a bottom lining of ganister (85% quartz and 15% clay) is tamped in at a level 6 in. below the tuyeres. A sectional prismoidal form, or pattern, the shape of the intended cavity, is set in position, and between this and the shell the lining is firmly tamped with iron tampers or rammers to the level of the top of the form. The form is removed in sections, and the tuyere openings are made with a pointed rod. The top section is lined, and put on and bolted. The joint between the top and bottom sections is made with a softer mixture than the rest that is composed of 72% quartz and 28% clay. The lined shell is dried and heated with a wood followed by a coke fire as has been described. It is important to have abundant converter-shells, so that they may have time to dry thoroughly and become heated before using, since otherwise the life of the lining is shortened. When thoroughly hot the shell is ready to be put on the stand.

Necessity of silicious lining.—Ferrous oxide is produced in the first blowing, and by itself it would be infusible. To slag it, silica must be supplied with which it can combine. Without silica, an infusible mass of iron oxide would accumulate in the converter. It is not possible for example, to use a converter with a basic-lined or water-jacketed shell. It has been tried, and it would save the time and expense of putting in linings daily, but the experiments have failed. The life of the lining is shorter the lower the grade of the matte, because with much FeO coming from the matte, a large

quantity of slag of basic quality is formed. The lining also is liable to fall off in lumps after being undercut in converting. The slag produced in converting 60% copper matte may be as high as 40% silica, while with a 35% matte, the resultant slag may be as low as 25 per cent.

107. SMELTER AND CONVERTER-PLANT.

Fig. 143 and 144 represent respectively the elevations and plan of a blast-furnace plant with a two-stand converter-plant attached, the size of the latter being indicated by the number of stands or stalls in which copper matte can be blown. In the elevation the receiving track for coke is shown at the extreme right of the illustration. The ore-bins with the inclined bottoms are shown to be on the same level. In the furnace building there are two matting blast-furnaces, each 42 by 144 in. at the tuyere-level and each having a settler or fore-hearth 10 ft. diam. Blast is furnished to the furnaces from a power house, not shown.

In Fig. 143 is shown the semi-elliptical flue 3 ft. wide by 7 ft. high, leading from the blast-furnaces. This crosses the end of the furnace building, as indicated by the dotted lines in Fig. 144. It is connected to a dust-chamber which leads to a stack. The slag is taken away over an electric-trolley system (See Fig. 137) entering the building. The slag-cars are brought close to the settlers to receive the flowing slag, while the matte, as needed, is tapped from a lower tap-hole into the steel ladle for transferring to the converters. A platform elevator, at the end of the furnace building, elevates slag and other material from the floor of the converter building to the charge-floor for the blast-furnace.

The converter building has at one end the lining floor, and is commanded, from end to end, by a 40-ton electric traveling crane which serves to handle the converters, to supply them with matte to take away the slag, and to handle all materials for and from the converters. For each stand there should be at least two extra shells or six in all. The escaping gases from the converters are received in a hood attached to a dust-chamber (See Fig. 143) so that the particles of matte blown out by the blast are collected. From the hood a flue connects with a dust-chamber and this communicates with a stack.

At one end of the furnace building (See Fig. 144) is the mill where the lining material is prepared for the converter. It consists of a 10 by 16 in. Blake crusher and 27 by 14 in. rolls for coarsely crushed quartz needed for the lining. The quartz thus coarsely

crushed, is mixed in a 5-ft. mud mill or wet pan (Fig. 145) with clay, to form a coherent lining material or ganister. It may consist of a silicious gold or silver-bearing ore mixed with clay. The advantage in the use of ore is that the gold and silver are taken up by the copper as the lining is consumed. Compressed air from the

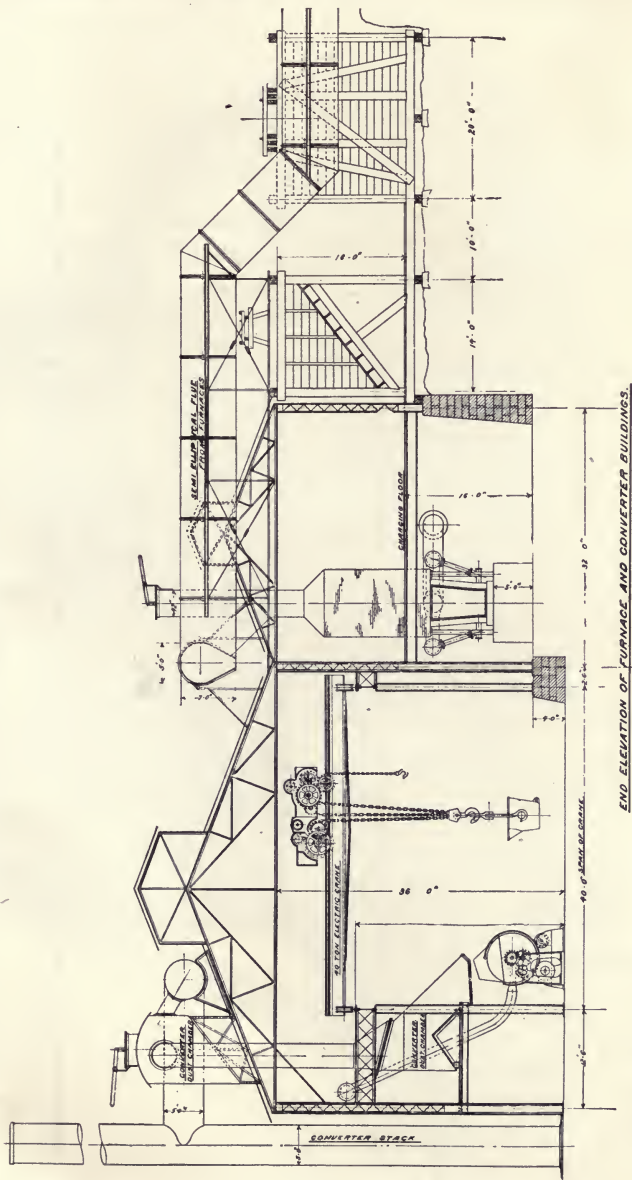

Fig. 143. ELEVATION OF SMELTING AND CONVERTING PLANT.

capable of delivering 300 cu. ft. of air per tuyere, or 2500 to 3000 cu. ft. per min. for each converter. This engine of the duplex compound type has steam cylinders 17 and 32 in. diam. respectively, and air cylinders 36 in. diam., all having a stroke of 30 in. and delivering 5600 cu. ft. of air per minute at a pressure of 10 lb.

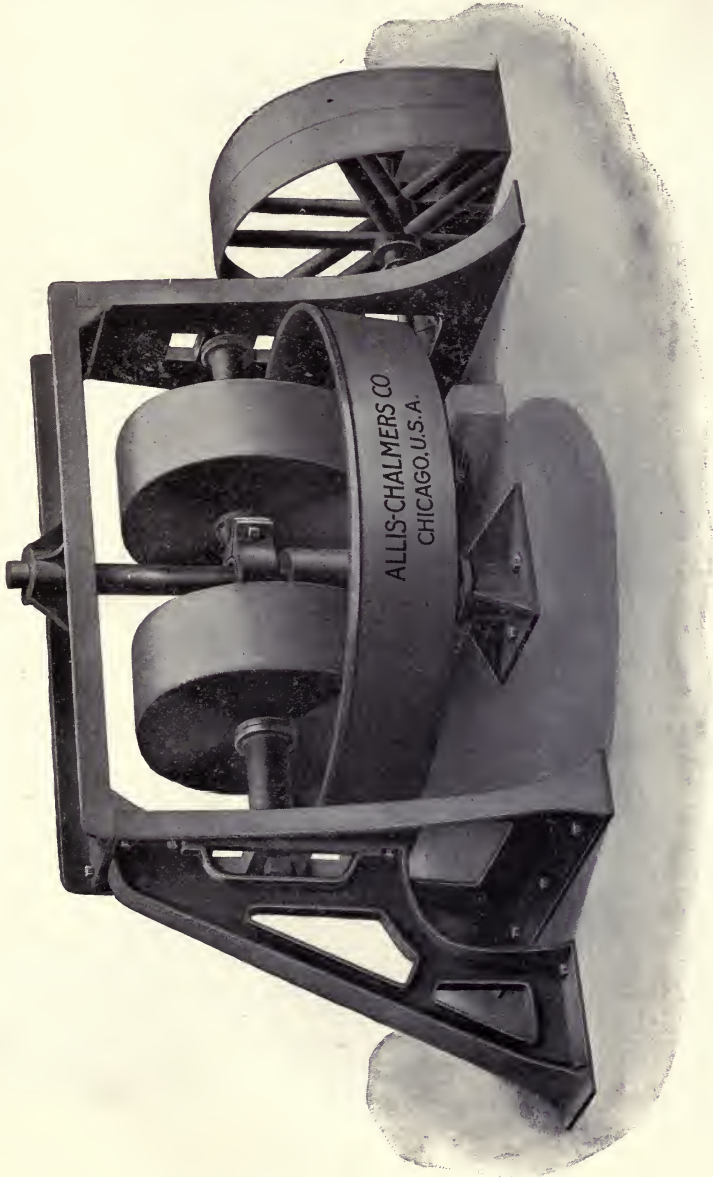

FIG. 145. WET PAN.

per sq. in. and capable of supplying the two converters. The converters are operated with a hydraulic cylinder having a pressure of 175 to 500 lb. per sq. in. from a pump. The demand for the water is irregular, and to regulate the supply the hydraulic accumulator (Fig. 147) is used. It consists of a fixed vertical cylinder in which a weighed plunger slides, the weight being a sheet-steel cylinder

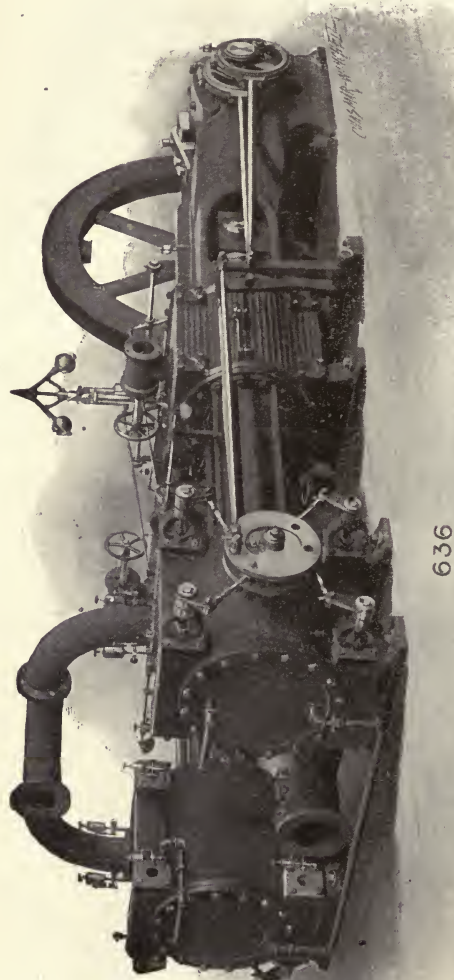
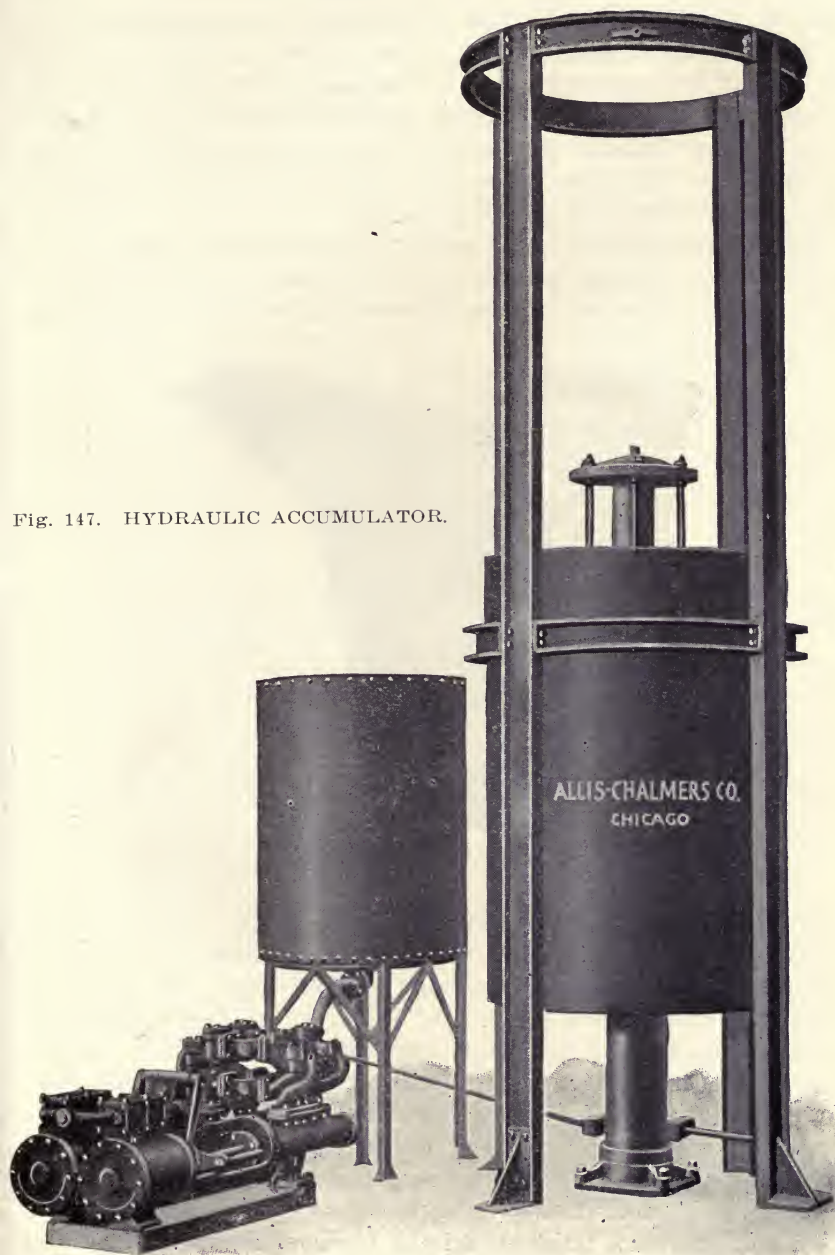

FIG. 146. HORIZONTAL BLOWING ENGINE.

Fig. 147. HYDRAULIC ACCUMULATOR.



filled with pig-iron weighing 15 to 20 tons. When water is used quickly, the plunger falls and maintains the full pressure, while in the intervals of rest, a duplex pump fills the accumulator. Slag is received from the converter in cast-steel ladles (Fig. 148), and matte is supplied from the settlers of the blast-furnace, or from the reverberatory furnace. The ladles have a capacity of 5000 to 12,000 lb. of matte. They are plastered on the inside with a coating of clayey loam which is dried before using.

The ingots or pigs of copper cast in the molds are rough on the upper surfaces, owing to the escape of occluded gas at the time of solidification. Blisters form on the surface, hence the term blister-



Fig. 148. CAST-STEEL LADLE.

copper. For electrolytic refining the pigs are smelted at the refinery, poled, and cast into anodes. The re-casting gives a smooth and even surface that is important in the electrolytic bath. To obtain smooth anodes at the United Verde works, Jerome, Arizona, a reverberatory melting furnace has been used. Into this the copper is poured from a ladle as the converters supply it, and every morning the molten copper accumulated is poled, to reduce the copper oxide present, and then molded into anodes. While the poling and casting is going on, no copper can be put into the melting furnace. It is cast into ingots, as in the older way, and when the casting of anodes is finished and the furnace is empty, the ingots cast during the interval are placed in the melting furnace for beginning the next charge.

108. LOSS IN CONVERTING.

The gas from the converter consists of nitrogen with sulphur dioxide, and traces of volatilized metals (As, Sb, Te, Pb, Zn, Cu, and Ag). The loss of gold, as in pyritic smelting, is small, but the loss of silver depends upon the amount of the volatile metals. A part of the copper and silver is recovered in the flues with the flue-dust caused by the blast. The silver in the flue-dust in one case was found to be 28 to 64 oz. at the branch from the converter hood, 22 to 65 oz. at the first part of the flue-chambers, 19 to 46 oz. farther along the flue, and 17.5 oz. per ton near the stack. Thus, the larger the chamber, the greater is the amount recovered.

The loss in treatment is 1 to 1.5 of the copper and 2 to 2.5% of the silver. In attempting to treat matte from silver-lead blast-furnaces of 40% copper and 10.2% lead, the silver loss was serious, amounting to 33 to 40%, due to the lead, which entirely volatilized, and carried silver as it does when present in a copper-matting charge in a blast-furnace.

109. COST OF CONVERTING.

Hixon, in his 'Notes on Lead and Copper Smelting and Refining,' gives the following as the cost per pound of copper of converting matte of 40 to 50% copper when the matte is re-melted in a cupola before converting.

	Cent.
Re-melting matte.....	0.20
Labor and materials for re-lining.....	0.25
Labor on converter.....	0.10
Re-smelting converter slag.....	0.05
Supplies	0.05
	<hr style="width: 50px; margin-left: auto; margin-right: 0;"/>
Total	0.65

For direct-matte, taken molten from the furnace, the cost is 0.40c. to 0.45c. or \$8 to \$9 per ton.

110. THE HYDRO-METALLURGY OF COPPER.

The wet methods of extracting copper from the ore consist in obtaining the copper in water-solution either with or without the aid of other solvents. The copper must be in combination with elements that cause it to be soluble in the solvents used. From the clear or filtered solution the dissolved copper is precipitated, and then melted and refined by igneous methods. In order to extract

metal, the ore is first rendered suitable in form for dissolution, by crushing, and if necessary, by roasting it.

Copper is extracted profitably from suitable ore of as low grade as 0.5 to 1.5% copper, when the conditions of abundant and easily exploited supply and cheap labor prevail. Ore containing the copper as oxide, carbonate, or sulphate is best suited to the work, but ore containing lime, magnesia, ferrous oxide, or manganese oxide, is less desirable. If the ore contains limestone, and can stand the expense of roasting in a kiln, then the caustic lime can be leached out with water and the ore treated for the extraction of the copper. Copper-bearing sulphide also is profitably treated for the extraction of the copper, the ore being oxidized until the copper is in the form of sulphate, soluble in water. Sulphide ores also have been roasted with salt, to bring the copper into the form of chloride, which then is extracted with a brine solution.

It would seem that extraction methods should be superior to others since the worthless gangue, which is the largest constituent of the ore, remains untouched, and the solvent acts on the relatively small quantity of valuable metal. Particularly does this seem true of silicious ore, which is expensive to smelt, and the silica of which in no way interferes with leaching. Experience, however, has taught that the wet-treatment of ore on a commercial scale is not generally profitable. In the United States, the ore, the capital, and the skill in handling have not thus far resulted in any high degree of success with wet-processes, though it is possible that it eventually may be brought about. In Mexico the labor conditions and climate are more favorable. With large and suitable bodies of ore it is possible that leaching can be made profitable. Such work, however, must be conducted under the direction of skilled and experienced metallurgists.

111. EXTRACTION OF COPPER FROM COPPER-BEARING SULPHIDE.

We may divide the sulphide process into the two following types:

(1) Conversion of the copper into soluble form (sulphate), leaching the copper salt, and precipitating the copper from the filtrate with scrap-iron (Rio Tinto process).

(2) Conversion of the copper into chloride, extraction with a salt-solution, and precipitation with scrap-iron or sulphur dioxide (the old and new Hunt and Douglas processes).

112. THE RIO TINTO PROCESS.

This well known method, practised so successfully at Rio Tinto in Spain, consists in preparing large heaps of copper-bearing pyrite, allowing it to oxidize by the use of a regulated quantity of air and water, and, when the copper has become sulphate, leaching with water to extract it. The clear solution is conducted to tanks filled with pig-iron where the copper precipitates.

When the copper in the ore occurs as chalcopyrite, CuFeS_2 , or as covellite CuS , oxidation proceeds slowly and imperfectly, and successful working requires chalcocite (copper glance), Cu_2S . It is because of the extent of the orebodies and the cheapness of labor that the method has been successful.

Method of working.—A site is chosen upon impervious sloping ground for suitably draining the solution. A clayey or rocky bottom is required, or one properly puddled and lined with clay to render it impenetrable.

The heaps contain 100,000 tons of ore and are constructed as follows: On the ground is first arranged a net-work of flues, 12 in. square, made of rough stones. Vertical flues or chimneys that connect with the ground-flues are built, 50 ft. apart, as the heap is made. The ore is broken to 3 to 4 in. diam., and the lumps are screened from the fine. The ore is dumped and spread on the pile in alternate layers, until the height of the level top of the pile is 30 ft. The top surface is formed into squares, by ridges of fine, so as to insure an even distribution of water through the heap. Launderers are provided to conduct water to all parts of this surface. As the heap is forming, water is supplied to extract any copper sulphate already existing. Oxidation starts as the result of the wetting. The completed and wetted heap begins to oxidize rapidly as shown by the heat evolved, the temperature of the air in the chimneys rising to 80°C . As the temperature rises, the lower ground-flues are closed to control oxidation and to distribute the action through the heap. The surface assumes a brown color, due to the dehydration of the basic ferric salt that forms, and heating is made apparent by this drying action. Great care is taken to prevent the heap from catching fire.

By the combined action of air and moisture, the following reactions occur:



The ferrus sulphate easily oxidizes to ferric sulphate thus:



The ferric sulphate acts on the chalcocite, and changes it to sulphate thus:

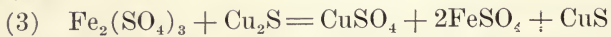

The cupric sulphide, hitherto unacted upon is further changed as follows:

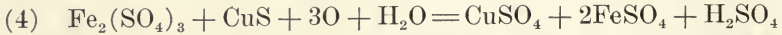

Reaction (3) is relatively rapid, and accordingly about half the copper goes into solution in a few months. Reaction (4) is slow but in two years, under favorable conditions yields 80% of the remaining half of the copper.

When oxidation has advanced as far as is safe, water is applied at the rate of 220 gal. per min. until the soluble copper salts are extracted. The flow is stopped and oxidation is resumed, and is followed by renewed washing. After a year the top surface needs 're-tilling'; the ridges are arranged where the squares formerly were, and the launders are shifted to conform. At the sides of the heap the ore to a depth of a few feet becomes cemented and holds copper salts. The sides are dug down in terraces to expose the copper salts and extract them by washing. When there remains unextracted but 0.3% copper in the ore, extraction is considered complete.

The copper sulphate solution that flows from the heap contains ferric sulphate, and to prevent it from consuming iron in the precipitation tanks, the ferric sulphate is reduced by running the solution through a filter-bed of fresh pyrite. The reaction is as follows:

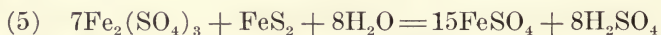

The bed is retained within a reservoir formed by a masonry dam across a small ravine. The liquor or solution, after percolating the bed, remains in contact until drawn into the precipitation-tanks. The solution entering the tanks contains Cu 0.4%, Fe_2O_3 0.1%, FeO 0.2%, H_2SO_4 1.0%, and As 0.03%. The large quantity of FeO and H_2SO_4 is due to the fact that a part of the waste liquor from the precipitation-tanks is pumped back and used for watering the heaps, so that the solution tends to concentrate.

The liquor drawn from the filter-bed is run through precipitation-tanks containing pig-iron piled in open order, and the copper is precipitated (replacing iron which dissolves) in the form of a 'cement copper' or 'copper precipitate.' The tanks are arranged on the slope of a hill, and the liquor passes back and forth, through the tanks, until it is discharged free from copper from the lowest series. Some of the tanks of the system are by-passed daily, the

liquor meanwhile going through the remaining ones. The tanks cut out are drained, and all the pig-iron is removed and piled beside them, the copper attached to the iron being meanwhile knocked off and thrown back into the tank. The muddy precipitate is now removed to the cleaning and concentrating plant, while the pig-iron is piled back into the tank and the liquor again directed through it. Under the best conditions there is needed 1.4 tons of pig-iron per ton of copper precipitated.

The crude precipitate containing 70% copper, at the cleaning plant, by means of a strong jet of water is gradually worked over and through a copper-plate screen placed at the head of a launder. The over-size of the screen, consisting of leaf-copper and small pieces of iron, is thrown into a heap and picked over by girls to remove the scrap-iron. The fine that passes through the screen is turned over under a stream of water that washes out the dirt and light particles, leaving the copper.

At the head of the launder for a few yards is found No. 1 precipitate, 94% Cu and 0.3% As. Farther along is No. 2 precipitate 92% Cu. Next comes No. 3 precipitate, which is fine and contains 50% Cu, 5% As, graphite (from the pig-iron), and the bismuth and antimony precipitated from the liquor. No. 1 and No. 2 precipitates are sacked for shipment, and No. 3 is added to a blast-furnace matting-charge, the copper forming matte, while the impurities mostly volatilize.

113. THE OLD HUNT AND DOUGLAS PROCESS.

In this process the copper-bearing sulphide is crushed and then roasted to convert the copper to oxide. The copper is extracted by a combined ferrous chloride and salt-solution as cuprous and cupric chloride. The solution is filtered and the copper finally is precipitated upon scrap-iron.

The copper-bearing pyrite ore is dry-crushed to a 4-mesh size for roasting. It is then thoroughly roasted until the copper sulphides are converted to oxide, the roasting being preferably done in one of the mechanical roasters provided with a fire-box to supply the extra heat needed to effect a complete roast. The cost of roasting is the principal expense of the process.

The roasted ore is transferred to a leaching vat, that has been carefully painted inside with asphalt paint to protect it from the action of the solution. The percolating solution is prepared by dissolving 120 parts ^{sodium} ~~ferrous~~ chloride, and ~~adding~~ 280 parts green vitriol ($\text{FeSO}_4 + 6\text{H}_2\text{O}$) to 1000 parts water. ~~The~~ the solution

In'

^{00 parts of} common salt is added. By standing, sodium sulphate crystallizes, leaving a strong briny solution containing ferrous chloride. When the solution meets the ore, the ^{and Cu₂O} CuO reacts as follows: ~~and dissolves.~~

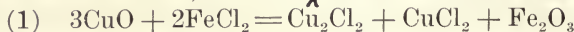

~~Insoluble ferric oxide and the soluble cupric chloride, if present in the ore and contained in the excess of cuprous chloride, reacts thus:~~

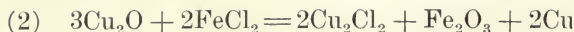

But the copper with cupric chloride reacts as follows:



The cuprous chloride is soluble in the salt-liquor.

The copper-containing filtrate from the filter-vats passes to precipitation tanks or to launders containing scrap or pig-iron, and the copper precipitates as follows:

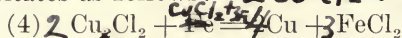

Ferrous chloride is regenerated, and the final liquor, after passing through the boxes, is used again.

The process has an advantage over the precipitation of copper sulphate by iron in that less iron is required. In reaction (4), ³ ~~one~~ equivalents of iron (¹⁶⁸ ~~56~~) precipitates ⁷ ~~4~~ of copper (³⁵² ~~128~~). The objection urged against the process is that the reaction of air upon the ferrous chloride solution is to decompose it, forming an oxychloride thus:

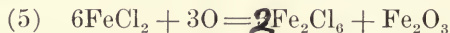

The ferric oxide formed in reaction (1) and (2) also tends to clog the filter. To avoid the difficulties the process was altered to the following one.

114. THE NEW HUNT AND DOUGLAS PROCESS.

The ore is crushed and roasted as described for the old process, then treated with a dilute solution of sulphuric acid to dissolve the copper oxide, and give a filtrate of copper sulphate containing ferrous and ferric sulphates. The solution is delivered into a precipitating-tank, and a solution of ferrous chloride is added which transforms a part of the copper sulphate into cupric chloride (CuCl_2).

Sulphur dioxide, obtained by the roasting of ore, is now forced into the liquid. It precipitates the copper as an insoluble cuprous chloride, as follows:

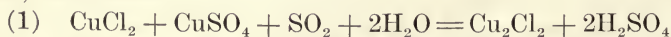

The cuprous chloride is filtered off and treated with milk-of-lime, or with iron according to the reaction (4) of the old process. The

consequent FeCl_2 is used in the treatment of the next charge, while the copper precipitate is shipped away. The sulphuric acid solution of reaction (1), filtered from the cuprous chloride, is freed from the excess of SO_2 by blowing into it hot air from an injector, and the recuperated solution is used again to dissolve ore.

The method has the advantage that no ferric hydrate is formed to clog the filter, and that but little iron is needed to precipitate the copper, and that precipitated copper is pure. It has been used for the extraction of copper from the matte rather than from the ore.

115. EXTRACTION OF COPPER FROM OXIDIZED ORES (NEILL PROCESS).

This process depends upon the use of a sulphur dioxide solution for dissolving the copper. The copper is subsequently precipitated by heating the filtered solution and expelling the SO_2 gas. It is used preferably upon oxidized ore, such as native carbonate and oxide, which is soluble in an aqueous solution of sulphur dioxide, but not in water. The process can be used also in the treatment of roasted copper-bearing ore. Lime and magnesia consume sulphur dioxide and are objectionable.

For oxidized ore, or carbonate, the crushing is done with rolls, which reduce the size to 20-mesh. The ore is then charged into a leaching barrel, like that used in chlorination, and water is added. A stream of sulphur dioxide is forced into the barrel by means of an air-compressor until the pulp is saturated with the gas. The saturation is maintained some hours, until the copper compounds have dissolved. The sulphur dioxide is produced by the roasting of iron sulphide in a pyrite-roaster.

From the barrel the ore passes to filter-presses where the solution is removed, the residual tailing being rejected. The solution passes to the precipitation tanks where it is heated by steam and boiled until the SO_2 gas is expelled.

The liquid, now freed from SO_2 , no longer retains the copper in solution. The copper comes down as a cupro-cupric sulphite ($\text{CuSO}_3, \text{Cu}_2\text{SO}_3 + \text{H}_2\text{O}$), a heavy crystalline compound of a dark-red color, containing 49.1% copper. The supernatant solution from the precipitating tank runs to waste through launders containing, as a precaution, scrap-iron to insure removing the last of the copper. The precipitated sulphite readily settles from the solution. It is washed by decantation, dried, and reduced and melted in a reverberatory furnace giving metallic copper.

The process has the advantage that a unit of copper, converted into cuprous sulphite, needs but half the sulphur that would be required to convert it to cupric sulphate. Cuprous sulphite is here precipitated from the solution without the use of scrap-iron. This is an advantage in remote districts where the cost of transportation is high. Sulphur dioxide has little action upon other metals, and thus a pure copper is furnished by this process..

116. THE HENDERSON PROCESS.

The well roasted residue, or cinder, resulting from the pyrite used in making sulphuric acid, contains 2 to 4% copper, with silver and gold. All these metals can be extracted by a chloridizing roast followed by leaching with weak liquor from a previous operation, and containing water and dilute hydrochloric acid. The copper in the clear filtrate is precipitated upon scrap-iron.

Operation of plant.—Fig. 149 shows the plan and a transverse sectional elevation of a 200-ton plant of the Pennsylvania Salt Manufacturing Co., Natrona, Pennsylvania.

The cinder (red-roasted or burned pyrite) that is brought from the various sulphuric acid plants throughout the country is ground dry to 20-mesh in a pan-mill, Fig. 145, and mixed during the grinding with 12% of the weight of salt.

The mixture is raised by a belt-elevator to storage bins (not shown) commanding the charge floor *k*. It is weighed in 5-ton charges and put into the charge-tubes of the muffle roasters shown in the longitudinal sectional elevation, Fig. 150. There are four charge-tubes, each 20 in. diam. for each furnace. The gases from the fire pass along the 14-in. space above the 8 by 35-ft. muffle-hearth containing the ore, thence by a flue downward to the space below the muffle, and finally by a main underground-flue to the stack. The gases from the roasting ore pass by an 18-in. pipe to condensing towers *a*, filled with lump coke that is wet by a spray of water above. The water, coming in contact with the ascending gas, absorbs the chlorine and hydrochloric acid.

Raw pyrite is charged with the ground cinder to make the sulphur content $1\frac{1}{2}$ times that of copper. The charge is heated to a visible red heat ($525^{\circ}\text{C}.$) and well stirred during 8 hours. When finished, it is drawn out upon the floor, allowed to cool, shoveled into charge-cars, raised by platform-elevator to the charge-floor level, and put into the leaching tanks *d*, each of which is 12 by 14 ft. in size.

The ore is first lixiviated with a weak liquor from a previous

operation to remove most of the copper. The solution becomes a strong solution. The ore is then treated with water, to remove the remaining copper and the solution becomes the weak solution of the succeeding operation. Finally, the weak solution of hydrochloric acid from the towers *a* is applied, dissolving the cupric oxide and cuprous chloride, hitherto insoluble. The residue, called 'purple

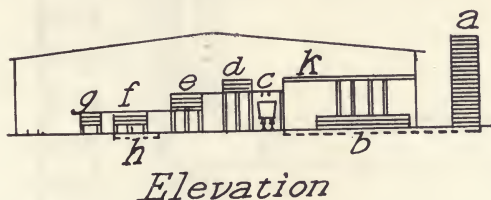

Elevation

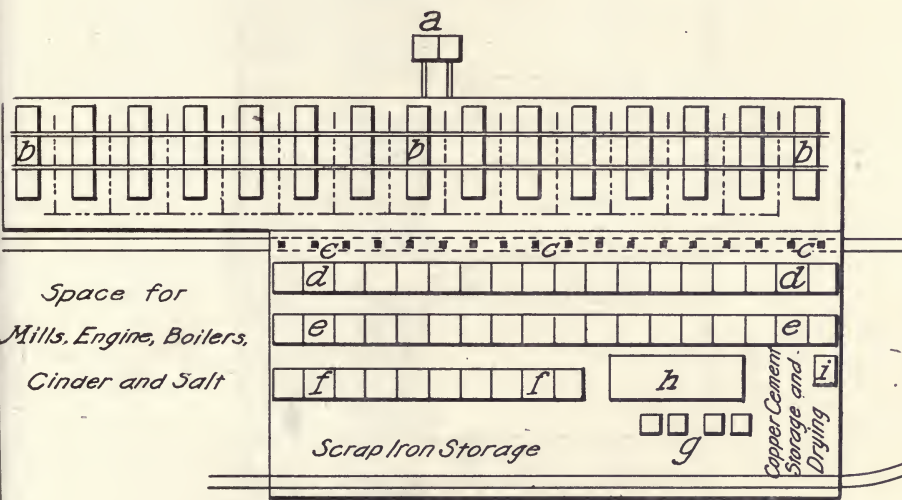

Plan

Fig. 149. HENDERSON-PROCESS PLANT.

ore' is shoveled from the vats to the floor *c* and thence discharged into the railroad cars below.

The weak solution is sent to the lixiviation tanks. The strong solution when the specific gravity reaches 18°B. is drawn to tanks 12 by 12 by 6 ft. where the copper is precipitated upon scrap-iron. The tanks have false bottoms of slats 2 ft. above the bottom. Live steam, directed into the solution, agitates it. The copper precipitating upon the iron works down between the slats to the bottom of the tanks and is removed to tanks *g*, 10 by 10 by 5 ft. The solution from this tank is drawn into launders containing scrap-iron as a guard, and to retain any remaining particles of

precipitate. The precipitate is 90% copper, 35 oz. silver, and 0.15 oz. gold per ton. It is sold to the blue-vitriol makers who pay

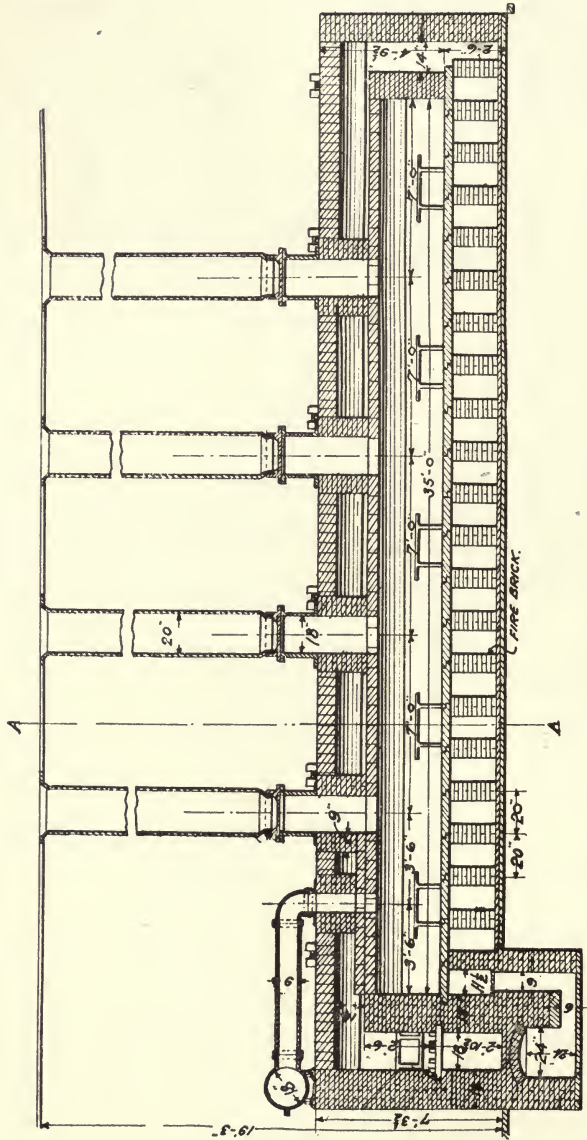

FIG. 150. MUFFLE ROASTING FURNACE.

95% of the silver and the full value of the copper and gold.

The cost of treatment by the process, with common labor at \$1.50 per day, is \$1.87 per ton of cinder treated.

PART VII. LEAD

PART VII. LEAD.

117. THE LEAD ORES.

The lead ores are those in which lead is the principal constituent. The term is applied also to mineral aggregates consisting of more than 10% lead. The lead ores may be divided into two classes: the sulphide and the oxidized. The terms are used only according to the constituent that is in excess, in many lead ores both sulphides and oxides are found. Ore containing no lead is called dry, and when carrying lead, leady. The latter term is the opposite of dry, but we do not term a leady ore a wet one.

Galena.—Pure galena contains 86.6% lead and 13.4% sulphur. In nature it occurs with gangue or vein-matter. When there is much of the latter it can readily be concentrated. The following table gives an idea of the lead-content of ore, before and after dressing:

GALENA ORES.

Locality.	Raw ore.	Concentrate.	
	Pb, %	Pb, %	Ag, oz. per ton.
Minnie Moore, Wood River, Idaho.....	...	62.0	80.0
Rockville, Wisconsin	0.3
St. Joseph, Missouri	7.0	70.0	...
Kellogg, Idaho	11.0	60.0	30.0
Col. Sellers, Leadville, Colorado.....	10.0	55.0	19.8

Galena from the Mississippi Valley contains little silver, but from the Rocky Mountain region it is not only argentiferous, but may contain gold. The precious metals as well as the lead determine the value. Metallic sulphides, such as pyrite and blende, are often associated with galena, and with the gangue may carry so much of the gold and silver that concentrating leads to a serious loss of the metals and is omitted. If by hand-picking ore can be brought to contain 30 to 40% lead, it is a desirable ore for the smelter. When of this tenor in lead, and free from other sulphides, it carries but 5% sulphur and needs no preliminary roasting, and is smelted directly.

Oxidized lead ores.—Little lead oxide is found in nature. The ores classed here under oxidized ores are the result of the alteration

of galena. They include the carbonate (cerussite) and the sulphate (anglesite) of lead. The minerals are mixed with metallic oxides and vein matter or gangue in nature, and when sandy or earthy, the ore is called sand or soft carbonate, and when hard and stony, hard carbonate. In many deposits we find ore, that originally was galena, profoundly altered to cerussite or anglesite. The subjoined table gives the composition of some of the so-called carbonates.

CARBONATE ORES.

Locality.	Pb, %	SiO ₂ , %	Fe, %	CaO, %	S, %	Ag. oz. per ton.
Southwest Missouri	72.0
Leadville, Colorado	38.0	25.0
Leadville, Colorado	21.0	22.5	18.2	2.4	0.9	65.0
Red Mountain, Colorado.....	18.4	41.6	11.4	1.7	1.8	128.0
Eureka, Nevada	33.2	3.0	24.1	1.1	2.0	27.5
Bingham, Utah	51.5	12.5	2.6	3.2	6.0	21.1
Horn Silver mine, Frisco, Utah...	50.0	15.2	3.4	0.5	8.3	78.3

Of the ores of the table, that from Eureka, Nevada, contains 4.2% of arsenic, which forms an arsenical speiss when smelted. The Horn Silver ore, apparently oxidized, has the lead in the form of anglesite (PbSO₄), and matte is formed from it in smelting. In oxidized ores the silver is apt to occur as a chloride, the gold probably is native.

There are many lead minerals but those not mentioned occur in small quantity and are not considered among the commercial lead ores.

118. RECEIVING, SAMPLING, AND BEDDING ORES.

Where ore is treated in a small way for the recovery of the lead, as in Missouri, no particular provision is made for storage. In various smelting works in the Rocky Mountain region, where lead ores are treated with others by methods of silver-lead smelting, and where ores are bought outright for treatment, the handling becomes complicated. Such plants are called custom works. A plant treating ore from a single mine is called a mine's works, and here less attention is given the sampling and storing of the ore. In customs works, therefore, ores of many kinds are received, some containing lead, some having little lead but carrying silver and gold.

The ore is received in lots of a few tons up to those of several carloads. Each lot is separately weighed, sampled as fully described in the chapter on sampling, assayed, and purchased. The company then is free to treat the ore as it pleases. If different kinds of ore were smelted separately the process would involve endless

change and labor, and so it has become the custom to 'bed' the ore in large bins holding several hundred tons. When so bedded the mixture is treated as a single ore. The different kinds of ore are unloaded separately into the bin and each kind is spread out in an even layer before the succeeding one is added. This is indicated in Fig. 151, and it is seen that we thus have a series of layers in a bin. When the ore is to be used, shoveling is done at the floor and all parts above fall down and mix, since a steep face of ore is constantly maintained. Thus a uniform mixture of the different ores is obtained for smelting, and so long as we are using

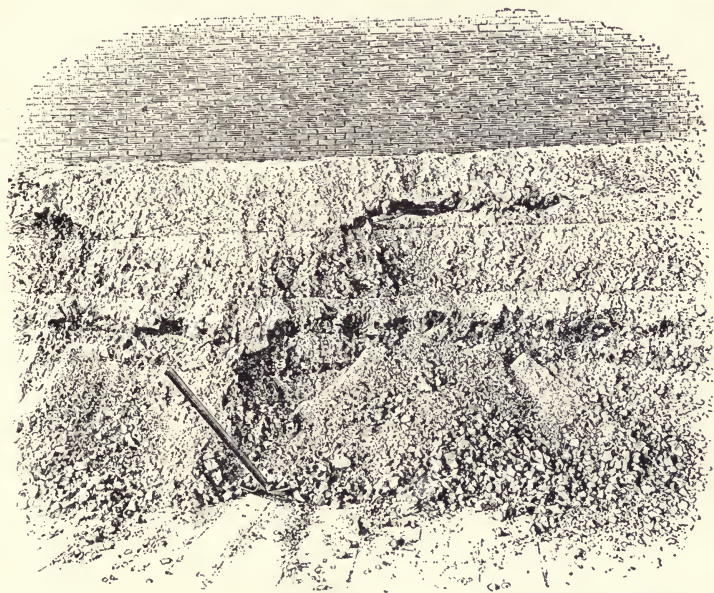

Fig. 151. ORE-BED.

ore from this bin, the quality remains constant. The supply remains practically unchanged in quality several days, and the content of the bed is treated in the books of the company as a single ore.

In the laboratory the aggregate analysis of the bed is obtained as follows: A list of the ores and the dry weights is prepared. The chemist weighs out, on his balance, from the reserved samples of each of the ores, an amount proportionate to the weight of ore in the bin. The total portion, amounting to one or two ounces, is thoroughly mixed, and from it portions are taken for the determination of SiO_2 , Fe, CaO, and S. The mixture may also be assayed for silver, gold, and lead, as a check on the calculated

content obtained from the weights and calculated assay of the individual ores. The determinations thus made are used in computing the charge.

Besides ore bedded in this way, lots that would fill a large bin remain unmixed, and the ore is treated as a separate item of the charge. Small lots, of which a moderate amount is to be used upon the charge, also may be kept separate, and such are called 'side ores.'

Crushing and bedding ores for roasting.—Sulphide ore that is to be roasted also may be bedded. When thus made uniform, it becomes known and is handled better at the roaster, and it makes a uniform product for the blast-furnace. Such beds are made to contain the proportions of pyrite, silica, and galena that work best in the roaster.

Crushing the sulphide is often performed in two stages. The coarse crushing of lumpy ore is done with rock-breakers, either of the jaw or the gyratory type, the ore being reduced to $\frac{3}{4}$ -in. size. It is then passed through rolls, 36 in. diam. by 14 in. face, where it is crushed to pass a 3 to 10-mesh screen according to the nature of the ore. A pyritiferous ore need be crushed no finer than 3-mesh, while ore carrying galena and blende roasts better when crushed to 10-mesh.

Sulphide ore is preferably bedded before roasting, because the men then soon learn how best to roast it, whereas with constant changes, they fail in this. Ores of different composition roast to advantage when judiciously mixed with a silicious pyrite ore. A pyrite ore, which readily starts to roast, assists the slow galena or blende. By combining different kinds we obtain a mixture that agglomerates only when the roasting is completed and the roasted material is ready to be withdrawn from the furnace. A bed formed of 10 to 15% SiO_2 , 20 to 28% Fe, and 20 to 28% Pb, roasts well. Mixtures containing less lead and more pyrite than this roast readily, but ore that is pulverulent, when roasted, tends to make more flue-dust in the blast-furnace, while with the proportion of lead above specified it tends to sinter and make a desirable lumpy product for the blast-furnace.

119. THE SMELTING OF LEAD ORES.

When lead-bearing ores are to be smelted only for the lead content, as is done in parts of the Mississippi Valley, a simple plant with a reverberatory furnace, or the American ore-hearth, is sufficient. In the Rocky Mountain region the lead ore is not smelted

to recover only the lead. The lead of the ore is employed as a collector of the gold and silver of other ores that are smelted at the same time. In the first case, a large part of the lead is recovered cheaply and simply, but a part is lost in the resultant slag. In silver-lead smelting it is essential that the slag be comparatively free from lead and the consequent silver.

120. REVERBERATORY LEAD SMELTING.

The treatment of lead ore in reverberatory furnaces has not made much headway in the United States. There are two reasons for this: In the silver-lead districts, the ore has not been of sufficient grade in lead to warrant the treatment, and lead ore has been in great demand as a collector to mix with other ores. Secondly, in the Mississippi Valley, where silver-free high-grade lead ores occur, the question of skilled labor for reverberatory-furnace work has had an influence.

The reverberatory lead furnace.—Fig. 152 and 153 represent one of the large recent furnaces, 16 by 9-ft. hearth dimensions,

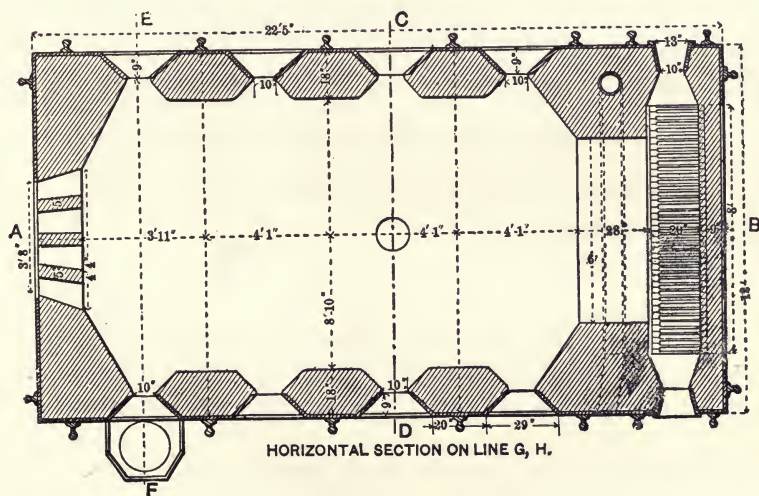

Fig. 152. LEAD-SMELTING REVERBERATORY FURNACE (PLAN).

having a fire-box 8 ft. by 20 in. or of 14 sq. ft. grate-area. The floor or bottom of the hearth slopes from the fire-bridge to the corner near the external well or basin *f* at the cool end of the furnace. The flame passes to the stack (not shown) by a flue at *a*. The charge is dropped into the furnace, as needed, through a 12-in. hole in the middle of the roof. There are four working-

doors on each side, so that the interior is easily reached to spread, rake, or withdraw the charge. The lead, as it forms, drains to the basin *f*, from which it is dipped from time to time as it accumulates, and molded into bars or ingots.

Operation of the furnace.—The operation is divided into two stages: the first that of roasting, or oxidation; the second, reduction.

Oxidation.—Four tons of ore, crushed to 5-mesh size, is dropped into the furnace from the hopper and spread over the hearth in a layer 3 in. deep. An oxidizing fire is maintained in the fire-box to raise the temperature of the charge to visible red (500 to 600°C.). The roasting is kept up three or four hours, and continued only until

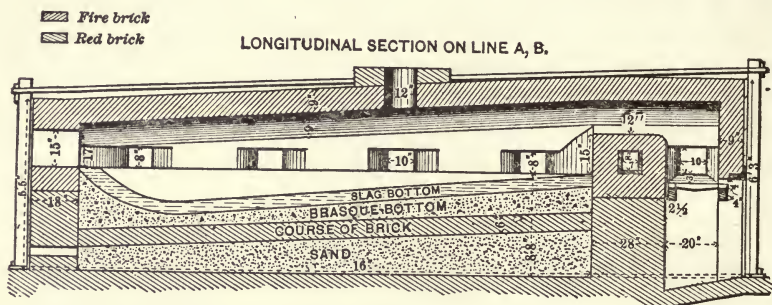
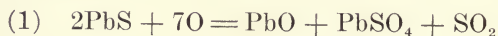

Fig. 153. LEAD-SMELTING REVERBERATORY FURNACE (ELEVATION).

an incomplete but definite degree of oxidation has resulted. The reaction is as follows:



The galena is converted in part into oxide, in part into sulphate. A part remains as sulphide. The temperature is kept at the required degree and the charge is frequently raked to expose new surface to the action of the air, and to prevent the agglomeration of the charge.

Reduction.—The fire-box is filled with a thick bed of coal to give a neutral flame, and the temperature is raised to the point at which the charge begins to soften, but not to melt. The oxide and sulphide of lead react upon the unchanged galena thus:



The metallic lead begins to flow. To stiffen the charge and make it less fusible and more open in texture, slaked lime is added and stirred in. The charge is rabbled at intervals to promote the

reactions. Finally the flow of lead ceases, but the pasty residue still retains half the original lead.

Further treatment.—To extract lead, a second roasting takes place, followed by a second period of reaction. It takes several of these operations to extract all the lead possible. Toward the end there remains no lead sulphide to react with the lead sulphate and oxide. To reduce these, slack coal or charcoal-breeze is mixed in, and a further portion is obtained. Each successive operation takes less time, and the temperature becomes a little higher as the charge becomes stiffer. The lead, as it drains away, is received in the basin *f*, and after skimming is molded into bars.

The residue, after extracting all the lead possible, is a gray slag still containing 12 to 30% lead, and having one-fourth the weight of the original charge. It may be sent to a blast-furnace where the lead can be recovered.

The process requires twelve hours for a four-ton charge and consumes 45% or 1.8 ton of coal. It is suited only to concentrate and to ores rich in lead, but not to those of more than 4 to 5% silica. Silica forms a silicate with the lead oxide and carries the lead into the slag. A small amount of metallic sulphide, such as pyrite or blende, is not harmful; indeed pyrite is beneficial at the roasting stage. Limestone, dolomite, blende, and iron oxide stiffen the charge and prevent premature melting.

121. THE ORE-HEARTH.

The ore-hearth cannot, as regards capacity, or cost per ton of ore treated, compete with the reverberatory furnace, nor can it be used in silver-lead smelting. As compared with the reverberatory it can be quickly started or stopped, and put in operation with little cost for fuel, so it well serves the purpose of extracting the lead from small amounts of low-silver ore, from time to time, by the men who themselves have mined the ore.

The hearth.—Fig. 154, represents a sectional elevation, a front elevation of the lower part, and a plan of an American ore-hearth. It consists of a cast-iron pan or crucible *a*, 2 by 2½ ft. by 1 ft. deep, to contain a bath of lead, and is built into the brick work *g*. The back *p* and the two sides *n, n*, above the crucible, are water-cooled castings. The blast from a fan-blower (not shown) enters by the tuyere-pipe *b* through the back at *o*. At *g* is a sloping cast-iron plate called the work-stone, and at *i*, a pot placed to recover the lead that flows down over the work-stone. The pot is kept

hot by a wood fire below. The structure is surmounted by a brick top to receive and carry off the fumes.

Operation.—By means of the blast, a glowing coal fire is made that fills the hearth. Residue from the previous run, containing metallic lead, and 15 to 20 lb. galena, not finer than pea-size, is spread over the fire. The charge soon becomes red-hot, and the lead, set free, finds its way to the crucible at the bottom.

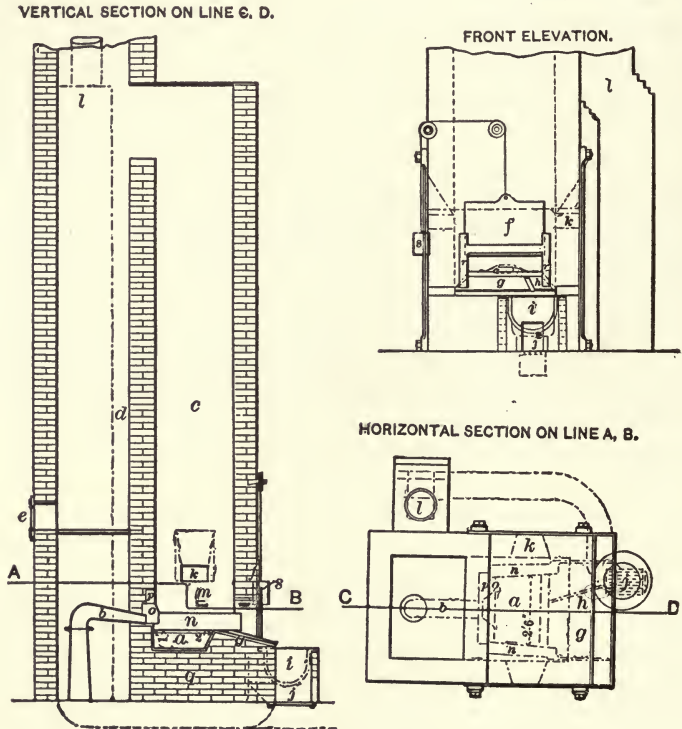

Fig. 154. AMERICAN ORE-HEARTH.

ore is then added, and the material in the hearth is pried up gently with a bar to keep the mass open and hot throughout. Lumps form, and are drawn out on the work-stone, and gray slag that forms at the same time is separated and the rich residue returned to the hearth. Ore and fuel are again added, 15 to 20 lb. at a time, and operations continue until lead fills the crucible, while on the top floats the fuel, unreduced ore, and half-fused material. One man with a bar at intervals loosens and stirs the charge, raising

it slowly, while another with a shovel draws upon the work-stone the half-fused mass floating on the lead. Here he separates and rejects the gray slag, and returns the rich residue to the charge. A fresh charge is then added, and the work progresses in the manner described. The lead overflows the crucible and runs down a groove made in the work-stone into the kettle. When the kettle fills, the lead is skimmed and ladled into molds.

The reactions in which the lead is reduced are like those of the reverberatory process. In the ore-hearth also, the glowing fuel, acting upon the lead oxide, reduces it to metallic lead.

To operate the ore-hearth, a blower and power to run it are needed. Much lead is volatilized, and so the treatment is not suited to argentiferous galena. The gray slag that is produced still consists of 35 to 40% lead, and is sold to smelting-works. The direct recovery of the lead is 75 to 85%, the higher figure having been obtained in recent practice.

122. SILVER-LEAD SMELTING.

This is a blast-furnace method of treatment, applicable to a great variety of ores containing lead, silver, gold, and even copper. By it, ore containing the precious metals with no lead, are treated with lead-bearing ores, thus using the lead of one ore as the collector of the gold and silver of another. The method is the most effective means of doing this. The precious metals are extracted from the ore by a blast-furnace treatment, using lead-bearing ores, carbonaceous fuel, and flux.

Oxidized ore can be directly smelted in the blast-furnace, but sulphide ore is first roasted. Methods of roasting are described in the chapter on roasting, and in the chapter under 'crushing and bedding of ores for roasting.' These have become important preliminary operations for the treatment of ore before it is smelted.

The ore to be treated is charged into the blast-furnace as in iron or copper smelting, with a calculated quantity of flux which for lead ore is iron ore and limestone. The precaution is taken to use lead-bearing ore to make the lead content of the charge at least 10%. It has been found that if a smaller proportion of lead than this is used, the precious metals are not so well collected in the base-bullion, or work-lead, produced in the smelting. To a charge as above constituted is added 15% or more of coke, not only to melt the charge but to reduce the lead oxide to metal and the ferric oxide to the ferrous form.

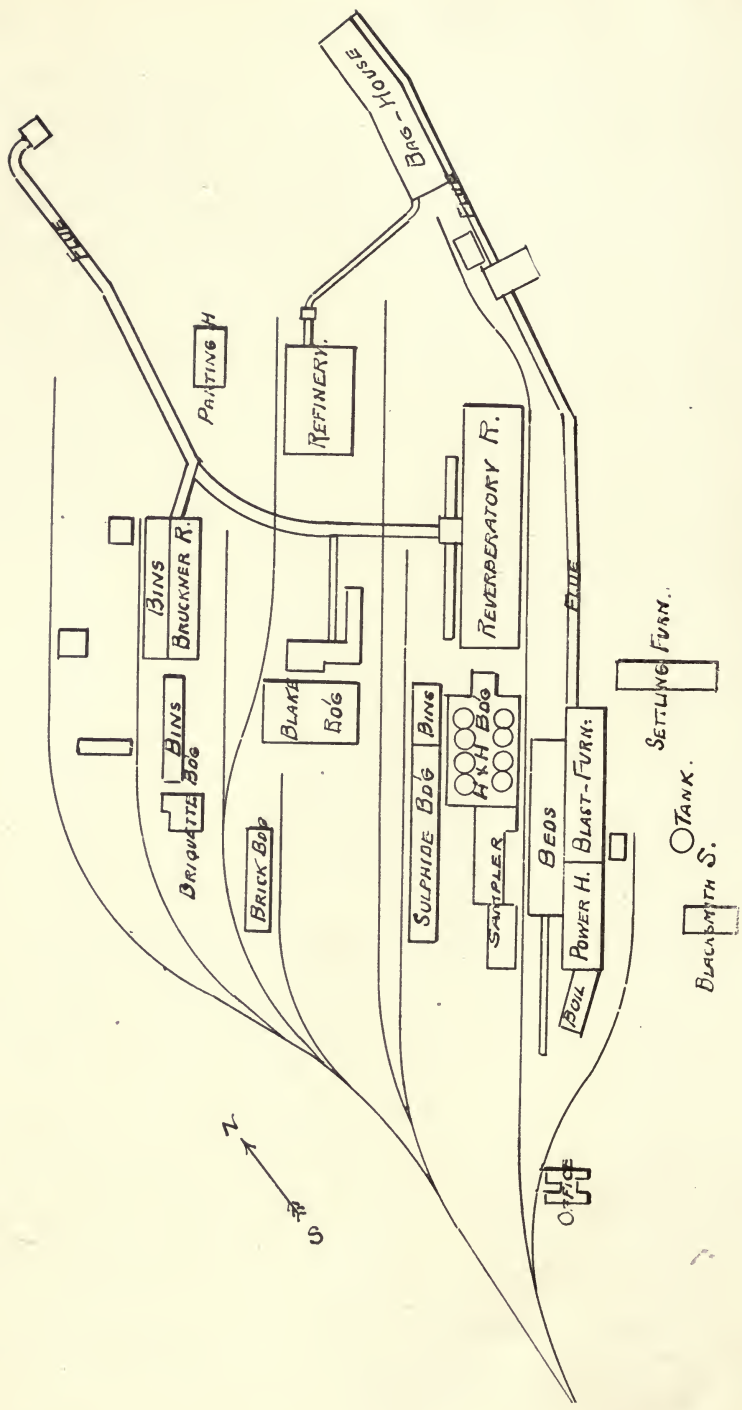

FIG. 155. GLOBE PLANT.

123. GENERAL ARRANGEMENT OF SMELTING WORKS.

Fig. 155 is the plan of a large and complete silver-lead works, the Globe plant of the American Smelting & Refining Co., near Denver, Colorado. On the feed-floor level are the blast-furnaces, the ore beds, the sampling building, the building for the pot-roasting or Huntington-Heberlein process, the building for the reverberatory-furnace, and the sulphide-mill where the sulphide ores are crushed preparatory to roasting. At the lower, or slag-floor, level, are the boilers, power-house, and settling-furnace building. The buildings of the two levels form a complete plant. At the northeast end of the works is situated the bag-house where the flue-dust is effectually separated. A long connecting flue leads from the blast-furnace to this. Back of the main buildings, and now not altogether in use, are the Blake and the Bruckner roaster buildings, a silver-lead refinery, and a parting-plant. A long flue leads from the reverberatory-roaster building and from the H.-H. building to the main stack. It would not be possible to turn the roaster fume into the bag-house because of the sulphuric acid it contains.

124. THE SILVER-LEAD BLAST-FURNACE.

Fig. 156 represents in section and side elevation, a water-jacketed silver-lead blast-furnace, rectangular in plan, 44 in. wide and 144 in. long inside the jackets at the tuyere level. Fig. 157 is a half section, and end elevation, and Fig. 158 is a view of the same furnace. The furnace comprises a crucible standing on the ground at the slag-floor level, the shaft, extending from the crucible to the feed-floor, and the stack or closed top, from the feed-floor through the roof of the furnace building.

The furnace foundation is made of rubble masonry, or of concrete. It extends from a solid footing to the slag-floor level in a solid mass over sufficient area to take in the corner posts. Where another furnace is in operation close by, the slag from it may, with little expense, be used for making a solid slag-block formation by filling the foundation-pit that is excavated for the purpose.

Upon the foundation rests the crucible shown in section in Fig. 156 and 157 and in perspective in Fig. 158, but in the latter the crucible is bound with steel-plates. The bottom of the crucible is a steel plate 8 by 16 ft. in area on which rests the inclosing crucible-plates of cast-iron securely bound with rods. Within is built the fire-brick crucible, 44 in. wide by 144 in. long inside by 2 ft. deep, the sides narrowing downward. At one side is a channel

8 in. square, extending from the sole of the crucible to the top level, and called the lead-well. In operation, the crucible and the

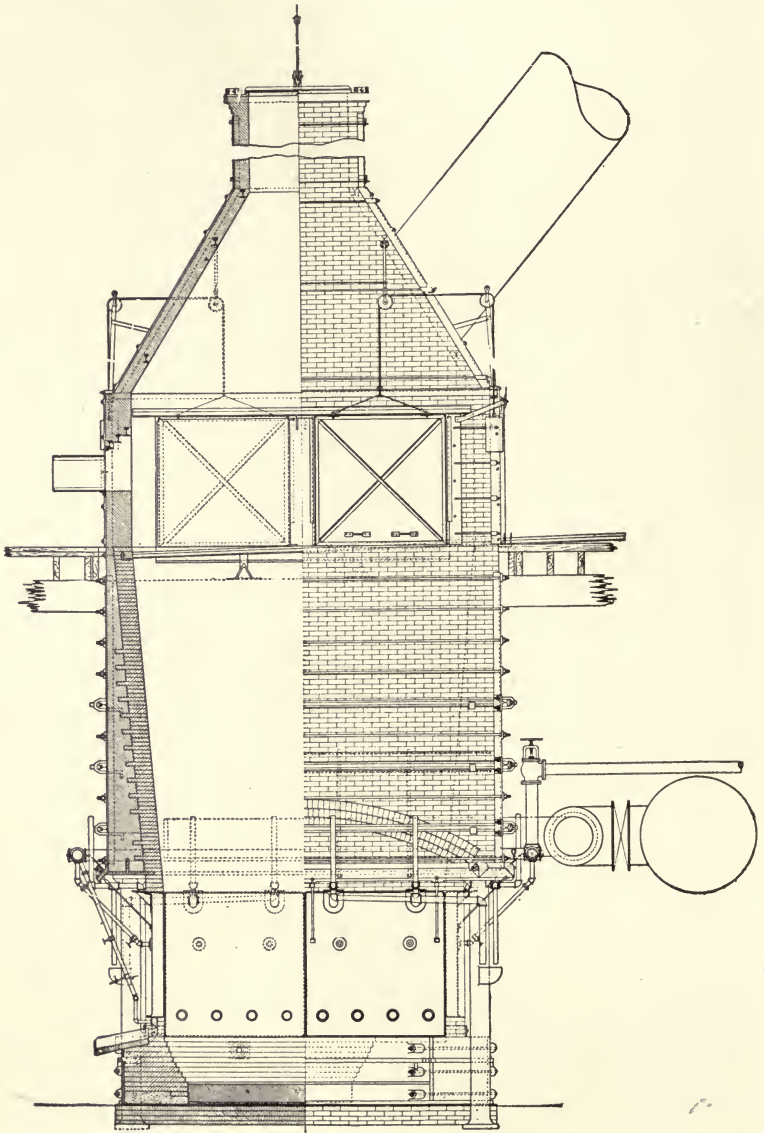

Fig. 156. SILVER-LEAD BLAST-FURNACE (LONGITUDINAL ELEVATION).

lead-well are full of molten lead. As lead accumulates in the crucible it rises in the lead-well, and can be removed. The circular

top-opening of the lead-well is shown at the front in Fig. 158. The jackets form the lower part or bosh of the shaft, and are made either

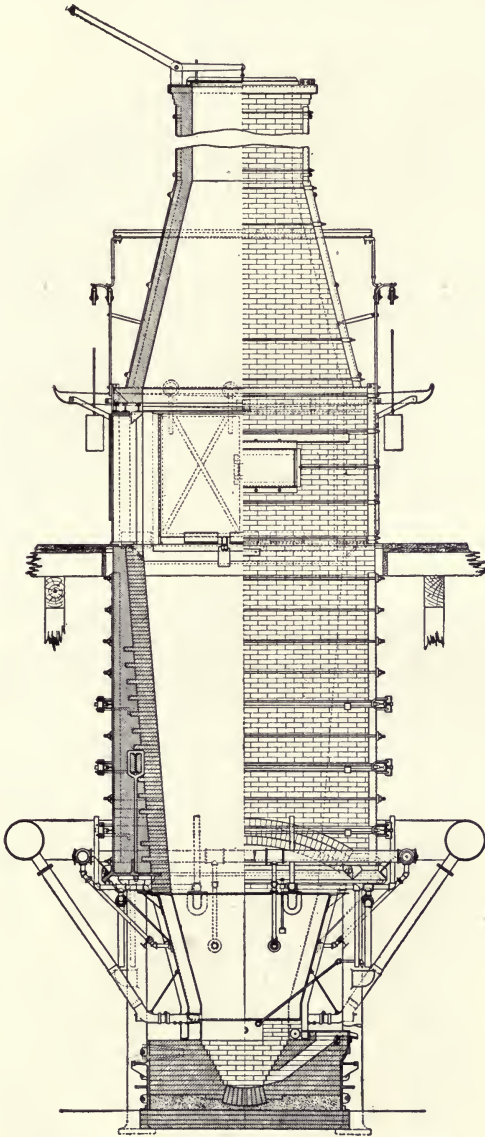

Fig. 157. SILVER-LEAD BLAST-FURNACE (TRANSVERSE ELEVATION).

of cast-iron or of steel. As seen in Fig. 156, 157, and 158, they are 6 ft. high. The side-jackets have tuyeres, making a bend, or knee,

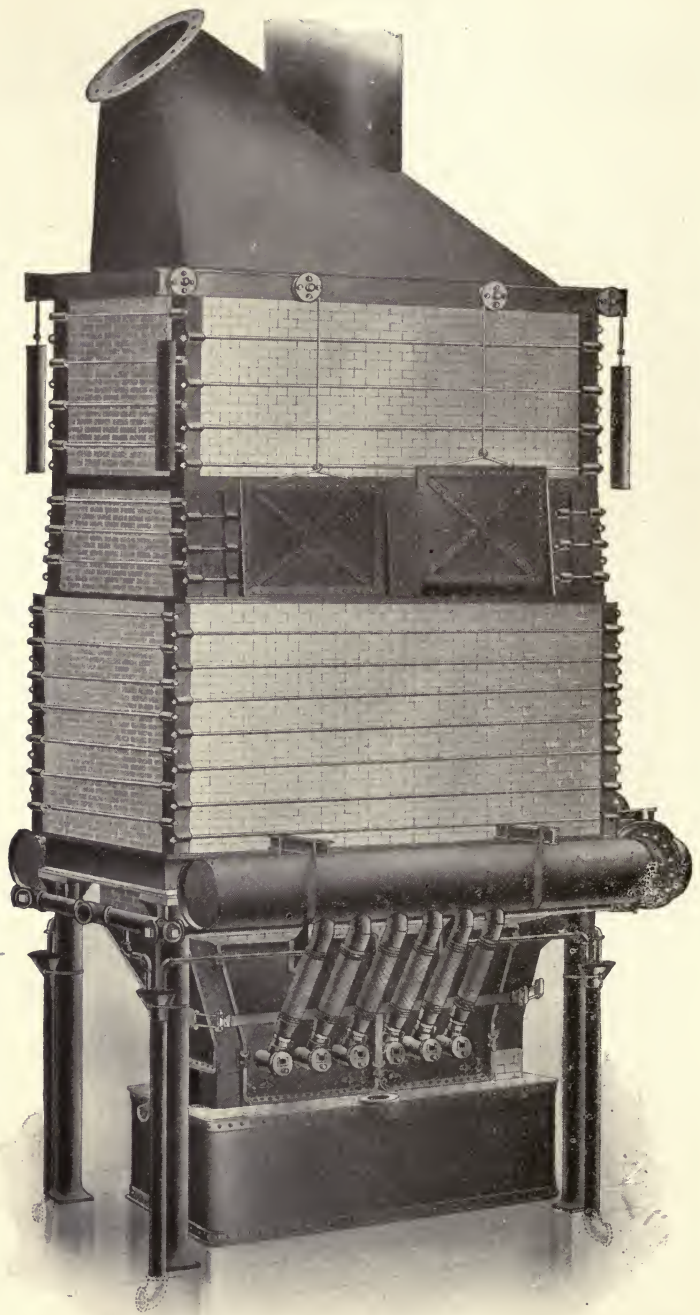

Fig. 158. PERSPECTIVE VIEW OF SILVER-LEAD BLAST-FURNACE.

in the jacket as shown in the illustration of the steel side-jacket Fig. 159, and in Fig. 157. At the top of the jacket is seen the spout into which the pipe enters that supplies the water, and at the front



Fig. 159. END WATER-JACKET, WITH KNEE-BOSH.



Fig. 160. END WATER-JACKET, STRAIGHT.

of the spout is seen the hole for the outlet water-pipe. Thus a circulation of water through the jacket is insured. Fig. 160 is a steel end-jacket without a bosh. The jacket is shown also in the

longitudinal view, Fig. 156. The end-jackets are made at least 12 in. shorter than the side-jackets so as to leave room below for the breast-opening. This space is generally filled with a tap-jacket. Jackets are also made of cast-iron, but are narrower than when of steel. A side-jacket, for example, taking in a single tuyere, is but 18 to 20 in. wide (See Fig. 161). Each jacket has a spout for receiving and discharging water as is the case with steel jackets. Hand-holes near the bottom are put in, so that accumulated scale, deposited from the jacket-water, can be removed. Fig. 162 is a left-

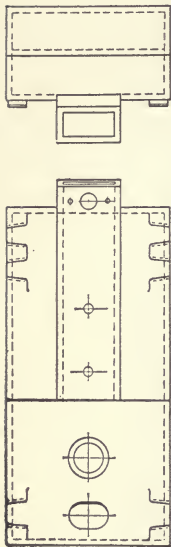

Fig. 161. CAST-IRON
SIDE-JACKET.

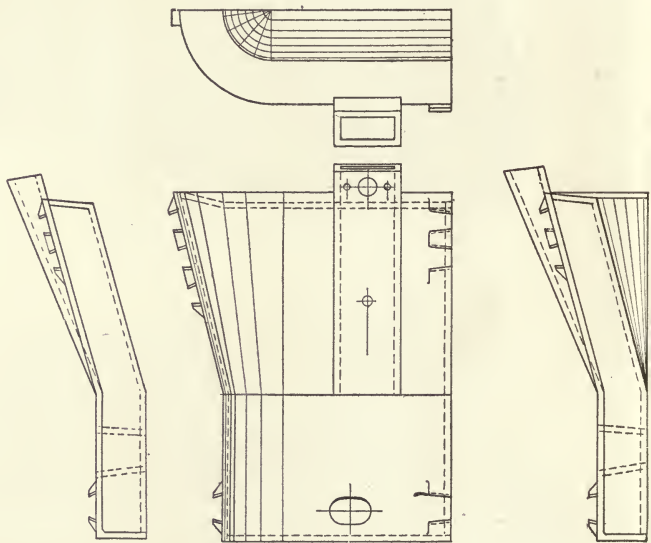

Fig. 162. CAST-IRON
END-JACKET.

hand end-jacket, the right-hand one, with it, forms the end of the furnace. In Fig. 156 is seen no bosh in the end-jacket. Often, as is indicated in Fig. 159, a bosh is provided. Fig. 162 shows a jacket having a bosh, and indicates the method by which it is connected with the side-bosh by a rounded corner. The object of the boshes is two-fold. They serve to support the charge, and they make the furnace larger above, so that the content descends slowly, and remains a long time in contact with the reducing gas. Also when accretions form in the shaft there is room thus left for the smelting operation.

Air is supplied to the tuyeres from the bustle-pipe shown in Fig. 156 and 157. Canvas sleeves are shown by which the connection

is made between the bustle-pipe and the tuyeres. The canvas makes a flexible connection, so that the tuyeres can be readily removed, as when the furnace has to be stopped for a short time. In fact, if the tuyeres were not removed, the canvas would be burned by the flame from the furnace.

A system of water pipes supplies the jackets, and another system takes the waste water from them to funnels at each corner post (See Fig. 158). The furnace shaft, extending from the top of the jackets to the feed-door, is lined with fire-brick, the whole being firmly tied with rods, and having angle-irons at the corners. The brick structure of the furnace is supported by a deck-plate or mantel resting on the cast-iron corner posts or columns.

Above the feed-floor is the closed top or stack, which collects the smoke and gas arising from the charge, and delivers it to the down-take, a 5-ft. pipe that rises from the furnace-top at an angle of 45° then descends at the same angle to the main flue. Thus no flue-dust can lodge in the pipe; it either slides back into the furnace or forward into the flue. When the furnace is run down the gas becomes too hot to send into the flue, and the damper at the top of the stack is opened to permit the escape. At the charge-floor level are large doors giving access to the furnace, for feeding and cleaning it when stopped for the purpose.

125. BLOWING-IN THE BLAST-FURNACE.

This operation may be divided into four parts, which are: warming the crucible, melting-in the lead, filling the furnace, and starting the smelting.

Warming the crucible.—This is done gradually. The breast of the furnace being open, a small fire with light wood is started in the crucible to expel the moisture from the brickwork. This takes 24 hours. The fire should be regular, the wood being placed at the walls of the crucible, and the middle left clear. When the fire has burned several hours, the charcoal and ash (both non-conductors of heat) accumulate. These are removed together with the glowing coals, with a long iron-handled shovel, and a new fire is built. When the brickwork seems dry, the fire is increased to warm it. To do this the tuyere sacks are tied up so that no air passes through them, and at the last tuyere a length of tuyere-sacking is attached to supply air to a 6-ft. piece of $2\frac{1}{2}$ -in. pipe. The blower being set in slow motion, supplies air vigorously through the blow-pipe to consume the wood. The lead-well, having a draft toward the crucible, is warmed at the same time with a fire of wood or charcoal.

Particular attention is given to warming the lead-well, and the heating is kept up until the outer brickwork of the crucible feels warm to the hand.

Melting-in the lead.—The hot crucible is cleaned out again and wood is put in which soon takes fire. Upon the wood is charged, with a paddle or 'peel,' a dozen bars of lead (base-bullion reserved from the last run of the furnace) which are speedily melted by using the temporary blow-pipe. More wood is added, followed by other bars, and so progressively wood is burned and lead is melted. When the crucible is half full, the fuel, charcoal, and ash are removed, a fresh fire is made, and the melting is completed. It takes 30,000 lb. of lead to fill a 44 by 144-in. furnace. The melting begun in the evening is completed, and the lead skimmed, when the day shift comes on at 6 a. m.

Filling the furnace.—Dry wood, preferably in long sticks and split 4 in. thick, is put on the lead bath. As much is used as can be inserted at the breast. The tap-jacket is next set in, and the breast is bricked up, while more wood is dropped from the charge-door to fill the space within the jacket to a level slightly above the tuyeres. A layer of charcoal, two feet deep, is added, followed by coke to a depth of 12 to 18 in. A number of charges of fusible slag follow, each with the regular quantity of coke, and a little iron ore and limestone to flux the ash of the coke. Ore charges next replace slag charges until charging is normal. Care is taken to fill the furnace evenly and quickly, needing the personal attention of the metallurgist or foreman with extra men.

Starting the smelting.—The furnace being filled half up to the charge floor and containing a few ore charges, fire is started at several of the tuyeres on each side by putting in a little greasy waste and lighting it. The tuyeres are at once put in place and the blast admitted at a pressure of 1 to 2 oz. per sq. in. The wood soon ignites and smoke rises through the charge. The blast is increased gradually during one to two hours, until the furnace is in full operation. As the slag accumulates it is tapped, while the lead, accumulating in the crucible and lead-well, is either dipped from the lead-well with ladles, or tapped through a lead tap-hole at the level of the top of the crucible. The amount of lead removed at one time is limited to 1000 to 1500 lb. to keep the crucible always full. The operation of filling and starting takes 7 hours.

Regular work on the charge-flood.—This consists in wheeling ore and fuel from the bins to the charge-scales, weighing the

required amounts into charge-barrows or charge-cars, then dumping the charge thus prepared upon the feed-plates in front of the furnace-doors. Every material except the fowl slag is weighed, and even the slag is added by shoveling in regular amounts. A charge is dumped on one charge-plate and the coke for it on the other. The coke is fed in an even layer, and the plate thus cleared receives an ore-charge. The ore-charge on the other charge-plate is then added, taking care to place the larger ore at the middle of the furnace and the fine at the walls and corners. Such a distribution should be made as to cause the smoke and gas to rise evenly throughout. The blast tends to ascend at the walls more than in the middle, but by the distribution it is compelled to rise evenly. The plate, now cleared of the ore-charge, receives the coke that is next to go in. The content of the furnace remains at the level of the charge-floor, new charges being supplied as the surface sinks.

Regular work at the ground or slag-floor.—This consists in regulating the water-supply at the jackets, seeing that the tuyeres are clean and open, tapping and stopping the slag, and when the slag and matte are separated in a fore-hearth, tapping the matte, placing the slag-pots (See Fig. 135), and removing them when full to the dump, tapping or dipping the lead (base-bullion) into molds, and removing and piling up the bars of lead that later are to be sampled.

The matte is tapped into pots or molds, and when solidified, is broken and sent to be crushed to 3-mesh size for roasting. The slag, as in copper practice, may be granulated and removed in a launder by means of running water. There is the objection to this, however, that, by reason of irregular working, matte may be carried away and never recovered from slag once granulated; hence removal in slag-pots is preferred.

When a pot of slag has been taken to the edge of the dump and has stood there a few minutes, a shell or 'skull' of solidified slag half-an-inch thick forms. A hole is broken through the top and the molten content is poured out. The shell is returned to the furnace for re-smelting. It is found to contain drops of matte that have settled from the molten slag and these are recovered only by smelting it. Slag is also conveniently removed by means of large slag-pots mounted on trucks and moved about by a horse or by an industrial locomotive, Fig. 137. At certain large silver-lead smelting-works the slag and matte together are taken to a reverberatory melting-furnace, called a settling-furnace, or settler, where the matte thoroughly settles from the slag, and is tapped just above the bottom of the furnace. The bath of slag is maintained 18 to 24 in. deep in

the furnace, and when accumulated, is tapped at a level a little below the surface, and delivered to a train of slag-cars operated by a locomotive. A fire with a smoky reducing flame is maintained in the settler. This gives a slag, cleaner by 0.3% lead and 0.3 oz. silver per ton than the ordinary method; but it needs the combined output of several furnaces to keep it hot and in good working condition. Where much zinc is in the charge the slag also may give trouble.

126. CHEMISTRY OF THE BLAST-FURNACE.

The surface of the charge should look dead, showing no visible heat or flame (over-fire). With much over-fire, there is a loss of lead due to volatilization. The moisture in the charge soon dries at the temperature of the rising gases (200°C.). The heat thus absorbed is small, and by calculation it is found to be but one-thirtieth of the total supplied by the fuel when 5% moisture is in the charge. As the materials of the charge descend in the furnace, carbon dioxide begins to be driven from the limestone, and the iron reduces from the ferric to the ferrous form. Half way down at a temperature of 800°C. the reactions are complete. The lead in oxidized form is reduced by the CO of the gas and by the red-hot coke. Galena reacts with the iron oxide and carbon as follows:

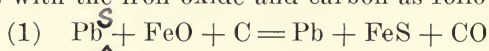

Sometimes scrap-iron is added to the charge, and acts with galena or other sulphides as in the nail assay for silver as follows:



As the lead, thus reduced, drops through the charge, it collects the gold and silver as well as a part of the arsenic and antimony and enters the crucible as base-bullion. When antimony is present it is reduced like lead and alloys with the latter. Anglesite is reduced by contact with the fuel and iron oxide according to the following reaction:

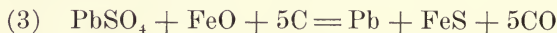

Where much anglesite is in the charge more than the usual quantity of fuel is demanded. Since the affinity of sulphur for copper is greater than for iron, copper sulphide remains unreduced, and copper as an oxide takes sulphur from the charge and with the iron forms matte. Lead to the extent of 10 to 20%, either as sulphide or in metallic form, is also taken up by the matte. To some extent zinc sulphide also enters the matte. The ferrous oxide, not needed to satisfy the matte, and the CaO and MgO in the charge, must be present in sufficient quantity to form a suitable fusible slag with the

silica. Oxidized arsenic compounds react with iron and carbon producing a speiss, often of the form Fe_4As , and requires extra fuel. The reaction is as follows:

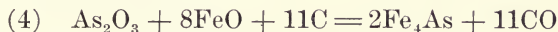

The molten products separate at the hearth according to the specific gravity, that of lead being 11.5, speiss 6.0, matte 5.2, and slag 3.6. The lead, collected in the crucible, is withdrawn at the lead-well. The slag, matte, and speiss are drawn off at the slag tap-hole on the level of the top of the crucible and of the lead. The separation of matte from slag is generally effected in a fore-hearth outside the furnace.

127. SLAGS IN SILVER-LEAD SMELTING.

The object of silver-lead smelting is to reduce the lead, and incidentally the gold and silver, from the ore. The sulphur present forms, with the copper, iron, and a part of the lead, a complex artificial sulphide (matte), while basic flux is added to form a slag of the composition that experience shows necessary.

Slags are silicates of extraordinary complexity; and not all merely fusible slags work well in a silver-lead blast-furnace. Type slags are those so proportioned in silica, iron oxide, and lime, as to work well in the blast-furnace. Slags that vary from the proportions become defective in operation. To fulfil the requirements of good slag, it should have, in the normal operation of the furnace, not more than 0.7% lead, or 0.5 oz. silver per ton, when producing base-bullion not higher than 300 oz. silver per ton. The density should not be greater than 3.6. It should not permit accretions to form at the hearth, nor the creeping-up or appearance of over-fire. If a slag varies from one of the types given, it is either poorly reduced or makes other trouble in the furnace. Thus a slag of the three-quarter type, in which the CaO falls to 20% (the other constituents as given in the table), is found to contain, for example, 1% lead, and more than 1 oz. silver per ton; that is, it is 'dirty.' It easily may happen that a dirty slag is fusible, but we know that the slag will work satisfactorily if correct according to the type, the other conditions of good running being in evidence. Indeed it is a common experience that a furnace, working poorly on an incorrect slag, begins to run well when a correct slag comes down. Following we give a table of type-slags that have been found to work well in practice.

TABLE OF TYPICAL SLAGS.

Type.		SiO ₂	Fe(Mn)O	Ca(Ba,Mg)O
		%	%	%
Quarter-slag	C	28	50	12
Silicious quarter-slag	H	32	47	11
Half-slag	E	30	40	20
Half-slag	J	31	38	21
Silicious half-slag	I	35	38	17
Three-quarter-slag	F	33	33	23
Silicious three-quarter-slag	M	36	31	23
Whole, or 1 to 1 slag.....	G	35	27	28

According to the ratio of FeO to CaO the slag is called a 'quarter,' a 'half,' or a 'one-to-one' slag, etc. Thus the slag E of the sub-joined table is called a half-slag, the CaO being but half of the FeO. The slag C is a quarter-slag, the CaO being quarter of the FeO. In this table of typical well-tested slags the three elements SiO₂, Fe(Mn)O, and Ca(Mg,Ba)O are calculated to comprise 90%. If the sum varies from this, the ratio is still to be preserved.

Since any of the slags of the table can be used, the question arises, which is to be chosen. In this we are guided by the economic conditions. If the ore of the district is silicious, and most profit is derived by treating the ore at hand, use a silicious slag that needs the smaller amount of flux. If irony or limey ores are plentiful and profitable to smelt we use them, substituting them for flux. It is found, however, that slags of the type M and G of the table drive more slowly, and require more fuel than the basic ones. Perhaps the most satisfactory of the slags, and the one that can be used where silicious ores are plentiful, is the three-quarter slag, F. When a slag of a certain type, for example a silicious one, is not working well and is forming accretions in the furnace, a radical change to a basic type is found beneficial, or from a basic slag to a silicious one.

128. ACTION OF VARIOUS BASES IN SLAGS.

Iron.—Iron ore is quickly reduced to ferrous form under the action of the CO in the furnace or of the highly heated fuel thus:



Iron oxide, being a stronger base than lead oxide, replaces it in the slag, and the latter is reduced by carbon to metallic lead.

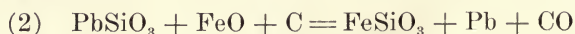

Manganese.—The equivalent for manganese is 55, and for iron 56, and they are reckoned as having equal values for fluxing.

Manganese is found in some of the Leadville iron ores to the extent of 10 to 15%, and since by introducing another element, it adds to the complexity of the slag, it also adds to the fusibility.

The alkaline earths.—Lime, magnesia, and baryta act in inverse ratio to the atomic weights in fluxing silica. Hence to obtain the equivalent in lime, the ~~amount of lime needed, expressed in per cent~~ is multiplied by 1.4 ~~for magnesia~~, and by 0.4 for baryta. A slag, high in lime and consequently low in iron like the last three in the table, is of low specific gravity. Its use thus results in a better separation of slag from the heavier matte. Lime being a stronger base by one half than iron, and generally a cheaper flux, the tendency is to choose the limey slags. It is noticed that the higher the silica content of the slags of the table the higher is the lime, and that high silica calls for high lime. Dolomite, having a high content in magnesia, generally is avoided in silver-lead smelting, for it tends to make slag pasty and streaky, and the unfavorable effect is aggravated when zinc also is present. Two analyses of limestone and of dolomite are given below to show conditions typical of actual practice.

Canyon City limestone: CaO, 49.8%; MgO, 3.0%; SiO₂, 3.1%; Fe, 0.8%.

Iron county, Missouri, dolomite: CaO, 26.6%; MgO, 17.6%; SiO₂, 5.1%; Fe, 3.3%.

Flourspar.—This has no unfavorable, but rather a favorable effect upon the quality of the slag. The fluorine, however, uses CaO, and hence the slag must analyse higher in CaO than the type requires, or it will not be clean.

Alumina.—It is uncertain whether alumina acts as an acid or a base. It is sufficient for the purpose of silver-lead smelting to regard it as a neutral constituent that dissolves in slag and acts in neither way.

Zinc.—Either blende or zinc oxide causes difficulties in the blast-furnace, the blende being the more objectionable. Blende is in part decomposed in the presence of iron to zinc oxide, but the zinc in any form tends to make a stiff, pasty, difficultly fusible slag. It may be regarded, like alumina, as being dissolved in the slag. It goes into both the slag and the matte, and diminishing the specific gravity of the latter it causes a less perfect separation of the two. Where much zinc is in the charge, it is customary to modify the type-slag by calculating the zinc oxide as replacing one half the percentage of lime. Take for example the half-slag J of the table.

	Without Zinc Per cent.	With Zinc Per cent.	Recalculated Zinc Per cent.
SiO ₂	31	31	29.5
FeO	38	38	36.0
CaO	21	17	16.0
ZnO	—	8	7.5
	90	94	90.0

In the first column we write the slag as the type requires. In the second column we add the 8% Zn and reduce the lime by 4% by which the total becomes 94. Since the constituents should amount to but 90%, all are reduced proportionally in the third column so as to give 90% as the sum.

Copper.—Copper present in the charge enters the matte when, as generally is the case, sulphur is present with which it can combine. In smelting carbonate or oxidized ores, which furnish no sulphur, the copper becomes reduced, and enters the base-bullion, giving a lead so drossy sometimes as to clog the lead-well, and accumulate and solidify in the crucible. The remedy is to supply sulphide to form matte into which the copper can enter.

Antimony.—Either as an oxide or a sulphide, antimony is reduced like lead. It alloys with the base-bullion, making it hard, and is removed and recovered later in refining the base-bullion.

Arsenic.—This frequently is encountered in silver-lead smelting. When present in small quantity it is volatilized, but in large quantity it forms a speiss. Where it is intended to produce a speiss, iron is provided with which the arsenic unites. In the fire-assay of arsenic-bearing lead ores, a bead of speiss is found attached to the lead button. From the percentage of this we can compute the weight of the speiss that will be formed; and we may assume that 70% of it is Fe. Where a direct determination of arsenic is made we can compute the weight, and multiply this by 2.3 to express the quantity of Fe to be provided on the charge for the purpose.

129. FUEL IN SILVER-LEAD SMELTING.

The fuels used in silver-lead smelting are coke, charcoal, or a mixture of the two. Wood and hard coal have been used experimentally, the former in certain cases of scarcity of fuel.

Coke.—Coke is the kind of fuel commonly used. The ash varies from 10 to 22%, and the fixed carbon from 89 to 77%. In coke of

high ash, not only is the ash to be smelted, but the carbon is correspondingly low, so that the coke is less efficient. A great difficulty with high-ash coke is that it is often friable, making accretions or scaffolds. Analyses of two typical samples of coke give the following results:

Connellsville coke contains fixed carbon 87.5%, ash 11.3%, and sulphur 0.7%. El Moro coke, fixed carbon 77.0%, ash 22.0%, and sulphur (when the coke is made from unwashed coal) 0.9 per cent.

In computing a charge the coke-ash is taken into account, analyses being as follows: Ash of Connellsville coke: SiO_2 , 44.6%; Fe, 15.9%; CaO, 7.0%; MgO, 1.9%; ash of El Moro coke: SiO_2 , 84.5%, and Fe, 5.0%.

Charcoal.—This fuel is used in districts far from railroads, where the cost of coke is high. It is a good fuel for oxidized ores, but is friable and makes undesirable fine which may form accretions or scaffolds in the furnace. It renders a charge more open than coke, and contains less than 2% ash. Coke weighs 25 lb. and charcoal 10 lb. per cu. ft. when loose, the weight of a bushel of charcoal being 14 to 16 lb. Even where charcoal is cheap it is desirable in operating the furnace to use part coke which, fed to the walls, burns more slowly than charcoal and makes the tuyere-zone hotter and gives a more liquid slag.

Quantity of fuel.—This varies according to the nature of the charge, and generally is from 12 to 15%. Charges that contain sulphur and make matte need less fuel than oxidized ores. Only sufficient is used to give adequate reduction and a hot slag; and the metallurgist is guided by these requirements in adding the fuel.

130. CALCULATION OF A CHARGE.

When sulphur-bearing, oxidized or silicious ore is used, we have to consider not only the sulphur, silica, and other constituents of the ore, but also the products of the furnace that remove the constituents.

Ore (galena for example) containing less than 10 to 12% sulphur generally is smelted without roasting. It is cheaper to do this, for by roasting, the sulphur of the ore is reduced to but 3 to 4%. Many ores within the above limit are leady ores, and difficult to roast because of the fusible nature, but the matte that they produce is easy to roast for the elimination of sulphur.

Ore intended for roasting may be simple, consisting of iron sulphide, or complex as shown by the following analysis of a roasted ore: SiO_2 , 10%; Fe and Mn, 27%; CaO, MgO, and BaO, 2%;

Zn, 8.8%; Cu, 0.4%, S, 6%; Pb, 35%, and Ag, 50 oz. per ton. The base in the roasted ore was present as sulphide in the raw ore.

The so-called oxidized ores consist of the carbonate of lead with a gangue of iron oxide, limestone, dolomite, and silica. Such ores though called oxidized, often contain a little sulphur, as sulphide (galena or pyrite) or as sulphate.

Silicious ores are added to charges, in spite of the large excess of silica, because the gold and silver are present in quantity to pay to recover. The lead of the charge takes the gold and silver contained in such ore, while the silicious gangue is fluxed into a barren slag and sent to waste.

Both iron ore and limestone are added to the charge for fluxing the silica, making a slag of a predetermined composition or type. If the fluxes contain gold or silver the metals can be recovered, since they go into the base-bullion or work-lead. Without gold or silver they are called barren or 'dead' fluxes. Ore carrying an excess of iron or lime over silica (called iron or lime excess) is in the same category, since the excess is useful for fluxing, and is credited in purchasing ores. Thus, ore containing 10% SiO_2 and 40% Fe is said to carry 30% iron excess.

Not all the slag that issues from the furnace is clean. At the spout where the matte flows, and in the shell lining the cavity of the fore-hearth, slag, containing drops of lead and matte, is found. When a slag-pot is emptied at the edge of the dump, there remains a shell or coating of solidified slag. This shell, half an inch thick, is found to contain drops of matte that did not entirely settle in the fore-hearth. This is particularly true when the fore-hearth has formed a thick lining and soon must be replaced by another. All this slag having value, and called 'foul slag,' is an acceptable addition to the charge because of the fusibility, and the coarse condition, permitting free passage of the air of the blast.

Computation of the charge.—To determine the amount of the fluxes (iron ore and limestone) to add to the charge, to give a slag of a desired composition, it is necessary to know the weight of the ores to be used, and the results of analysis of the ore, fluxes and fuel, and also the composition of the slag and matte that are to be produced.

First example.—Following is an example of a charge-sheet for the calculation of a charge containing no roasted ore. The charge is to weight approximately 1000 lb., a quantity sufficient to fill a charge-buggy.

CHARGE SHEET.

Name of Ore	Weight			Pb		SiO ₂			Fe and Mn		CaO and MgO		S		Ag	
	H ₂ O	Wet	Dry	%	Wt	%	Wt	%	Wt.	%	Wt.	%	Wt	Oz		
Chrysolite No. 28	3.0	515	500	21.0	105	32.0	160	15.0	75	10.0	50	4.4	22.0	75	18.7	
Ontario	5.0	52	50			60.0	30	2.0	1	2.0	1	0.5		75	1.9	
Iron Ore	2.0	204	200			4.0	1	57.0	114	3.0	6					
Limestone.....		200	200			3.0	6	3.5	7	54.0	108					
Coke		150				4.0	6	2.6	4	1.5	2	0.7	1.1			
			950		105		203		201		167		23.1		20.6	
						Fe for Matte =			33				11.0 \$ for Slag, etc.			
						Fe for Slag =			168				12.0 \$ for Matte			

½ Slag SiO₂ = 30.0 = 1.00 factor
 FeO = 40.0 = 31.1 Fe = 1.04 "
 CaO = 20.0 = 0.67 "
 90.0

Matte S = 20.0
 Fe = 55.0
 Cu = 5.0
 Pb = 15.0
 $\frac{\text{Fe}}{\text{S}} = \frac{55}{20} = 2.75$ factor

The items and the analyses of the charge are written in the proper columns. Lead ore, 'Chrysolite, lot No. 28' is used, to give approximately 10% or 100 lb. of lead. To this is added silicious 'Ontario ore' with the fluxes, to make up the remaining 500 lb. as experience shows necessary. If upon calculation we find that too little silicious ore, and hence too little flux has been taken to make up this 500 lb., we can increase it as needed.

Of the sulphur, we assume that 20% is volatilized, and that the slag retains 1% its weight of sulphur. From the silica we compute the slag to be equal to $\frac{203}{0.30}$ or 680 lb. Neglecting fractions we then have:

	Pounds.
Sulphur in slag ^{0.5%} 1% of 680 lb.....	6
" volatilized 20% of 23.1 lb.....	5
" remaining for matte.....	12
	—
	23

Multiplying the 12 lb. sulphur in the matte by the factor 2.75, which expresses the ratio of sulphur to iron, we find 33 lb. to be the amount of iron needed for matte. This leaves 168 lb. iron for the slag.

We have chosen a half-slag for this particular case, and find from it a factor of ($\frac{31.1}{30} = 1.04$) expressing the ratio of silica to

iron. Multiplying the weight of the silica by this factor gives 211 lb. iron needed. We have, however, but 171 lb., and the difference can be made up by increasing the iron by 40 lb., or the iron ore by 80 lb., since the iron ore is approximately one-half iron. Again, multiplying the factor expressing the ratio of silica to lime (0.67) by the weight of silica, we find 136 lb. needed, so that we have 31 lb. too much. Now, since the limestone is approximately one-half CaO, we diminish the limestone 60 lb. Erasing the old values and substituting the new ones we carry the calculation through again. The results should be correct within a few pounds, and may be corrected again if not so. Fractions of pounds are neglected, and the weight of the fluxes need not be written nearer than 10 pounds, since variation in the charge, due to variation in the ore and weighing, easily may be greater than fractions of 10 pounds.

The slag actually produced may vary from the desired composition. When a new charge has been put on, and after several hours the slag has come down, that is, has begun to flow from the furnace, it is analyzed and the result known in two or three hours. The charge is then altered to give a correct slag. Before making any changes we must be sure that the slag is hot and well reduced. The total weight of the charge can be varied conveniently by varying the amount of silicious ore, retaining unaltered the weight of the lead.

Second example.—For a charge that is to contain roasted ore or other sulphur-bearing material, the following sheet gives a good illustrative example.

We assume that 15% of fuel is to be used, and that the weight of the charge is to be 1000 lb. Let us say that we have ores coming in proportions to permit using them in the ratio indicated by the first two items of the charge-sheet (300 lb. roasted ore and 200 lb. lead ore). We can make up the remaining 500 lb. with silicious ore and flux, in the proportion that experience suggests, being assured that the lead-bearing ore furnishes about 100 lb. lead, or 10% of the charge. We find, including the lead in the silicious ore, that we have 104 lb. total lead which meets the requirement. Next enter the 150 lb. coke, estimating the percentage composition from the following data (for example of Connellsville coke) with 11% ash of SiO_2 , 44%; Fe_2O_3 , 22.7%; CaO, 7.3%; MgO, 1.9%. Since the iron has been reported in ferric form, we have to multiply the 22.7% Fe_2O_3 by 0.7 to obtain the equivalent iron. Magnesia being the stronger base, we multiply the percentage (1.9%) by 1.4 to obtain the lime-equivalent of the magnesia, adding

it then to the lime, making in all 11%. Estimating this for the coke, by the percent of the percent, we have SiO₂, 4.9%; Fe, 1.7%; Ca Oand MgO 1.1 per cent.

CHARGE SHEET.

Name of Ore	Weight		Pb		SiO ₂		Fe and Mn		CaO and MgO		S		
	H ₂ O	Wet	Dry	%	Wt	%	Wt	%	Wt.	%	Wt.	%	Wt
Roasted Ore.....			300	12.0	36	12.0	48	32.0	96	2.0	6	5.0	15
Lead Ore.....			200	25.8	52	22.6	45	18.1	36	5.4	11	2.0	4
Silicious Ore.....			200	8.0	16	63.3	127	16.0	32			3.0	6
Iron Ore.....			100			5.0	10	54.0	54				
Limestone			200			3.5	3			52.0	104		
Coke		50				4.9	7	1.7	3	1.1	2	0.7	1
			1000		104	240		221		123		26	
								Fe for Matte = 37		S volatilized = 5.0			
								Fe for Slag = 184		S in Slag = 6.0		11	
												15	For Matte

Slag.

SiO₂ = 33%
 FeO = 33%
 CaO = 24%
 Other bases = 10%

Fe = 25.7 = 0.77 × SiO₂
 = 0.73 × SiO₂

Matte.

20% S × 2.5 = S = 20%
 = Fe = 50%
 Cu = 5%
 Pb = 15%

100%

Slag = 730 lb.
 S in slag = (730 × 0.8%) = 6 lb.

Write in the constituents in percentage and pounds, footing up the columns to obtain the total for each constituent. All fractions are neglected. At the lower left corner of the charge-sheet write the type of slag chosen from the list of type-slags, section 127. The type chosen depends upon the kind found commercially to be the most profitable. This again depends upon the cost of flux and upon the ores that give the most profit in treatment. Where it pays best to treat silicious ore, one uses a silicious slag, but where there is more profit in an iron ore, then a basic slag is preferred. For the present calculation we choose the three-quarter slag, F, containing SiO₂, 33%; FeO and MnO, 33%, and CaO and MgO, 24%. The other bases such as ZnO, Al₂O₃, alkalis and sulphur make up the remaining 10 per cent.

The 33% FeO is calculated to Fe, making 25.7%. Finding the ratio of SiO₂ to Fe, we get the factor 0.77. For CaO we obtain, in the same way, the factor 0.73. On the other side of the sheet

tabulate a matte analysis, and calculate the factor expressing the ratio of S to Fe, or 2.5.

First consider the sulphur. Experience shows that, of the amount of sulphur present, we can estimate that 20% or 5 lb. will be volatilized, and also that the slag will contain 0.8% S. The weight of the slag is found by dividing the weight (240 lb.) by the percentage expressed decimally (0.33). This equals 730 lb. Hence there remains 15 lb. of sulphur to enter the matte, and this multiplied by the factor 2.5 gives 37 lb. Fe. This subtracted from the total Fe leaves 183 lb. for the slag. Multiplying the 240 lb. of silica by the factor 0.77, we find 185 lb. Fe, so that we are close to the calculated iron needed. Again, calculating the lime needed (240 multiplied by 0.73 or 175 lb.) we find we are short (175 minus 123) or 52 lb., equal to 100 lb. of limestone of 50% CaO. This increases the total of the charge 100 lb., and we may let it go at that, submitting to a little less than 10% lead on the charge; or we may decrease the silicious ore, which permits us to lessen the quantity of flux. Write the new figures 170 of silicious ore, and 270 of iron, and 260 of limestone, making in all 500 lb. for the three constituents, and, after neatly erasing the old figures, try again. The amended calculation will be nearly correct, or if not so, make a new correction with the figures erased and new ones inserted. The final sheet should be a fair copy. This second example is a simple one. Frequently the metallurgist adds other items to the charge, and methods, other than the trial one here given, are too complicated.

Since the atomic weights of Fe and Mn are nearly identical (56 to 55), we add the percentage of each metal to obtain the equivalent Fe. For MgO multiply by 1.4, and for BaO by 0.4 obtain the equivalent CaO.

131. SAMPLING AND HANDLING BASE-BULLION.

The practice at large silver-lead smelting-works is now to re-melt all base-bullion from the blast-furnace. Sometimes the lead is taken in molten condition to the re-melting kettle from the blast-furnace. When the lead is melted in the re-melting kettle it is carefully skimmed, and as in lead refining, the cleaned lead is molded into bars. The skimming or dross, containing copper and other impurity, is returned to the blast-furnace. The copper there enters the matte and the lead again goes to the base-bullion. While the lead is being molded samples are taken from the kettle at intervals, and from the samples the assay-results are obtained. The bars for a 40-ton car-load, 800 in number, are stamped with the number of

the lot, and are carefully weighed, 20 at a time. Careful assays are made of each lot, both by the shipper and by the refiner.

At smaller plants the punch sample is taken as described in the chapter on sampling. The results are exact.

132. FLUE-DUST.

A blast-furnace 42 by 120 in. takes 5000 cu. ft. of air per min. when in full operation. The escaping gas has an average temperature of 150°C ., and we calculate that the velocity of the gas rising through the charge is at least 5 ft. per sec. Additional air enters the feed-doors, especially at the time of charging, and particles of 20-mesh size may be carried into the down-take and to the flue that leads to the tall stack producing the draft. The flue, which is common to all the blast-furnaces, in some cases is made hundreds of feet long and of large cross-section, for the purpose of settling and collecting the particles called 'flue-dust.' Flue-dust, after suitable preparation, as for example by making it into briquettes, can be re-melted. It amounts to 0.8 to 15% the weight of the charge, but in good practice a near approach to the former figure is possible.

A little of the lead and silver, and much of the zinc and arsenic of the charge are volatilized. The volatilized substance in part adheres to the cool surface of the flue. Eventually it flakes off and falls to the bottom of the flue and is there recovered. Flue-dust, therefore, is composed of: (1) dust, carried along by the draft, and (2) lead fume, condensed on the cool surface of the flue.

All this material is not recovered; the finest part may escape. An analysis of flue-dust at Pueblo, Colorado, shows PbO , 37.6%; ZnO , 5.3%; Fe_2O_3 , 25%; Al_2O_3 , 1.3%; CaO (from the limestone) 5.3%; SiO_2 , 8.6%; S , 2.5%; SO_3 , 1.6%; H_2O , CO_2 , and C (from the coke) 11.2%. When arsenic is present in the charge a part condenses in the flue. Where in outlying regions, the lead has a low value, there is a point at which, in order to eliminate the arsenic, it is better to permit the loss of some of the lead.

There is a difference in the quantity of flue-dust made by a furnace according to the way it runs. A furnace having accretions or scaffolds in the shaft, or one driven with a large volume of blast, or one fed carelessly so that the gas fails to ascend evenly through the charge, increases the production of flue-dust.

The carrying power varies as the square of the velocity, or directly as the draft-pressure, therefore, to arrest as much flue-dust

as possible in the main dust-flue, it is made large in sectional area thus reducing the velocity of the gas.

Flues have been made of sheet-metal, but metal corrodes because of the sulphuric acid that is found in the gas or the sulphates that are in the flue-dust. Reinforced concrete has been used, but it also is somewhat attacked. Brick remains the favorite material for such construction. A flue built of reinforced concrete on the Monier system consists of an arched frame-work of angle-iron tied by longitudinal bars and covered by wire netting, or expanded-metal, the whole being plastered inside and out with a coating of cement-concrete. The bottom of brick flues is frequently made of sheet-steel hoppers. Since these are continually covered by the flue-dust, they are protected from corrosion and last a long time. A flue is rectangular in cross section and has brick walls, a low arched top, and a hopper-bottom, as above described, at such a height as to leave room beneath for a car running on a track at the ground level. The car can be set under any hopper and the content drawn into the car through a canvas sleeve fitted over the outlet spout to avoid dust.

Other methods, such as spraying water upon the dust-laden gas; the use of plates, called Freudenberg plates, hung in the flue parallel to the length; Rösing wires, a multitude of wires hung from rods parallel with the flue, all have been tried with a degree of success, but abandoned in favor of plain flues free from baffle-walls or other obstructions.

The two important considerations in the construction of flues are, first, a slow and general movement of the gas, in order to settle out the dust; and second, a large cooling surface for the condensation of the lead-fume.

133. BAG-HOUSE.

Fig. 163 is a transverse section of the bag-house which is coming much into use for the recovery of the flue-dust and lead fume by filtering the gas through bags that leave the resultant gas colorless.

It is a building 40 ft. wide, 200 ft. or more long and 45 ft. high, divided into two stories. The bags, of which there are several hundred, 20 in. diam. by 35 ft. long, are suspended from the beams of the roof by cords that, at the same time, tie the mouths of the upper ends. The second floor, 14 ft. from the ground, is pierced with openings 18 in. diam. with thimbles over which the lower ends of the bags are slipped and tied. The flue-gas is drawn in by a suction-fan and delivered into the lower story, beneath the second floor.

of it is carried down and smelted. The effective way is to make it into briquettes with milk of lime as a binder. Fig. 164 represents a plant containing a White briquetting-press for making briquettes composed of flue-dust and milk of lime to which is added fine roasted ore. At the right in the figure, shown to be on a high platform, is a pile of quicklime. This is fed, together with water, into the lime-mixer, a trough divided transversely by a partition. One compartment is shown as containing the lime being mixed to a thin paste, while the other is now empty. The paste is drawn from either compartment to a horizontal double-shaft pug-mill. Each

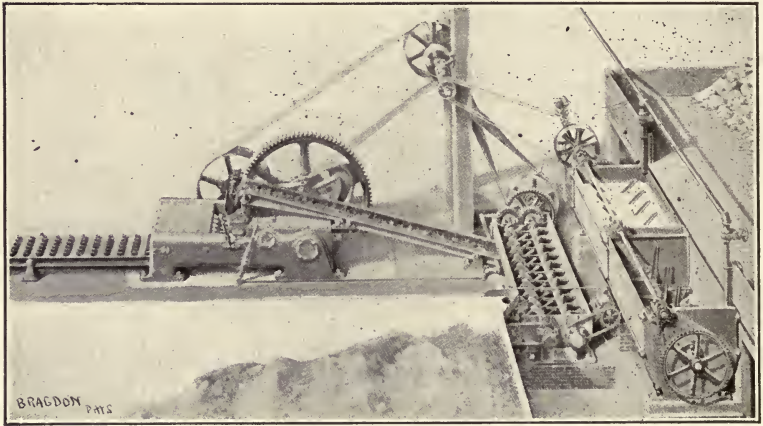

Fig. 164. WHITE BRIQUETTING PRESS.

shaft is provided with mixing blades. Flue-dust from the pile at the front of the lower platform is shoveled into the pug-mill and thoroughly mixed with the milk of lime by the revolving blades of the pug-mill which, being set at an angle, propel it to the discharge-opening immediately over a troughed conveying-belt. It drops into the hopper of a six-mold briquetting-press where it is made into briquettes that drop upon a flat conveying-belt, delivering them to a pile. The briquettes may be used at the blast-furnace freshly made, but the usual plan is to dry them, as clay-bricks are dried.

At times the briquetting is omitted, and the pug-mill mixture is wheeled to a drying-floor, or is distributed evenly upon one of the ore-beds. By the time the bed is used the mixture has set and become a hard mass capable of withstanding handling without being broken.

The lead-smelting charge generally contains copper, and the copper accumulates in the matte. Since matte is roasted and

135. LEAD-COPPER MATTE.

returned to the blast-furnace, the content in copper gradually increases. When increased to 12%, the copper matte is again roasted and treated in a separate blast-furnace, with silicious ore and oxidized copper ore, to produce a matte of 40% copper, called 'shipping matte' because it often is shipped to a copper works to be treated for the copper.

A satisfactory way of treating matte, where it is wished to produce a more finished product, is to crush it to a 4-mesh size and roast in a hand-roaster. It is next sent to a blast-furnace and again smelted with silicious and oxidized ores of high grade in copper. There results a matte 65% Cu and a proportion of bottoms, the result of the reduction of the copper from the matte. The bottoms are charged into a reverberatory furnace through the side-doors, and the coarse-broken matte is put on top. The doors are closed, and the charge is fired with an oxidizing flame, as in the Welsh process of 'roasting.' The charge having melted, a reaction of the cuprous oxide on the cuprous sulphide takes place, as described in the Welsh process of making blister copper; and the charge becomes reduced to an impure copper containing arsenic, bismuth, and antimony, as well as the gold and silver that were contained in the matte. The copper is then poled to reduce the cuprous oxide, and ladled into anode-molds. The anodes are sent to an electrolytic copper refinery for final treatment.

136. COST OF TREATMENT OF LEAD ORES.

To illustrate the method of calculating the actual cost of treating an ore, as in the Colorado or Utah silver-lead smelting practice, we take the case of a so-called neutral ore (SiO_2 equal to Fe). The ore is assumed to be oxidized, to contain less than 5% sulphur, and at least 10% lead. It is to be treated at a works having an output of 400 tons of charge daily.

The cost of treating a ton of charge, and of treating a ton of the ore including the flux, is as follows:

	Cost per ton	
	of charge.	of ore.
Labor	\$1.10	\$1.54
General expense, assaying, and management....	0.20	0.27
Fuel for power.....	0.07	0.10
Coke (15% of the charge) at \$6.50 per ton.....	0.97	1.36
Interest, improvement-fund, and repairs.....	0.26	0.36
Limestone (0.3 ton at \$1.25).....	0.37
Iron ore (0.1 ton at \$5).....	0.50
	<hr/>	<hr/>
	\$2.60	\$4.50

The figures in the second column are obtained by multiplying the total weight of the charge, 1.4 tons, by the cost of each item per ton of material, and then adding the cost of the flux. This corresponds to the figure above obtained, and may be stated again as follows:

1.4 tons of material (1 ton ore, 0.3 ton limestone, and 0.1 ton of iron ore) at \$2.60 per ton of charge for smelting.....	\$3.63
Cost of fluxes, 0.3 ton of limestone at \$1.25...	0.37
Cost of fluxes, 0.1 ton of iron ore at \$5.00...	0.50
	\$4.50

In case the ore contains sulphur in quantity to require roasting, \$2 should be added for the treatment. For sulphur over 5% and up to 10%, add 30c. per unit to cover the expense of iron ore for disposing of the extra sulphur, and roasting the matte made by it.

The application of this method of calculating costs may be illustrated with a silicious ore. We make a charge-calculation and find that for one ton of ore we need 1800 lb. iron ore and 1450 lb. limestone. Thus we have:

5,250 lb. or 2.625 tons of material of the charge at \$2.60 per ton.....	\$6.82
1,800 lb. or 0.9 ton ore at \$5 per ton.....	4.50
1,450 lb. or 0.725 ton of limestone at \$1.25	1.08
	\$12.40

This \$12.40 represents the actual cost of smelting a ton of silicious ore when the fluxes are paid for outright, and when run in a furnace also with suitable lead-bearing ores. In general, the lacking iron for the charge is made up in part by the excess of iron over that needed for the sulphur and silica contained in the roasted iron-sulphide, and in the other iron ores.

A ton of the above silicious ore makes 1.5 tons of slag which, containing 0.6% Pb and 0.6 oz. Ag per ton causes a loss in these metals of \$1.26 per ton. The self-fluxing ore above cited produces 1250 lb. slag and carries off only \$0.52. If we were treating this ore alone, of 100 tons treated daily but 38 tons would be ore; and from this all the profits of smelting would have to be obtained. In the case of the self-fluxing ore, 71 tons are metal bearing. Thus the room taken by the fluxes, called 'displacement,' is taken into account in figuring the profit of operation.

PART VIII. ZINC

PART VIII. ZINC.

137. PROPERTIES OF ZINC.

Zinc is a white, brittle metal of 7.1 to 7.2 specific gravity. Commercial zinc, called spelter, contains lead, iron, and cadmium as common impurities. Lead is found in spelter to the extent of 2 to 3%, but the amount can be reduced to 1% by refining. A small amount increases ductility, but it is injurious in the better grades of brass. Iron may be present up to 0.05%. Cadmium seldom occurs in spelter and has no deleterious effect, except when the metal is used for making zinc-white. It then discolors the product.

138. ZINC ORES.

The principal ores of zinc are blende and calamine. In New Jersey occur deposits of franklinite. The minerals seldom occur pure; besides the earthy gangue, and sulphides of iron, lead, and copper, ~~they are frequently contaminated with impurities,~~ combined, chemically, especially iron, which cannot be separated by ore-dressing methods.

Blende, or sphalerite, when of a yellow color as in the ore of the Joplin district in Missouri, is called rosin-blende. When dark in color, due to chemically-contained iron as in the ore of the Rocky Mountain States, it is called black-jack. It is from blende that most of the spelter of commerce is extracted. It needs roasting before it can be retorted or smelted for extracting the zinc.

Calamine is a term applied commercially to the carbonate (smithsonite) and to the hydrous-silicate of zinc. It is an oxidized or sulphur-free ore that needs no preliminary roasting before smelting. On being heated in the retort, the CO_2 of the carbonate is expelled, leaving zinc oxide. Willemite, the anhydrous silicate occurring with franklinite in New Jersey, mixed with coal is decomposed at the high temperature of the retort, yielding zinc. Nevertheless it is generally found advantageous to calcine calamine for the purpose of driving off CO_2 and water, which are undesirable in retorting because of their oxidizing action on zinc-vapor. However,

*Zinc-blende
the form
black jack
frequently
iron*

the preliminary calcination is often omitted, but when performed, it is done in kilns much like those in which lime is burned.

139. METALLURGY OF ZINC.

In outline, the metallurgy of zinc consists in grinding the ore (generally blende) and roasting to convert it into zinc oxide, then charging the roasted ore, intimately mixed with fine coal, into horizontal, cylindrical, clay retorts, heated to a white heat, where the zinc, reduced by the coal, volatilizes, and the vapor, entering the cool, tapering, clay extension of the retort (called the condenser), collects there. As it accumulates it is tapped into a ladle from time to time, skimmed, and cast in molds. When distillation is complete the condenser is removed and the content of the retort taken out and generally thrown away. The cycle of operations takes 24 hours.

140. ROASTING BLENDE.

The aim is to dead-roast the ore, generally to 1% sulphur or less. For every 1% sulphur remaining in the roasted ore, 2% zinc is held back in the retort-residue after distillation.

The ore is ground to 8-mesh size then slowly and carefully roasted with frequent stirring, finishing the roast at a high temperature to decompose the zinc sulphate formed at the lower temperature. The ore is generally in the form of concentrate, still containing a little gangue, galena, and pyrite. To remove the final 1% of sulphur would require a long time and would not be commercially profitable. The ore is accordingly considered to be finished when it contains no more than that amount of sulphur.

141. CHEMISTRY OF ROASTING ZINC ORES.

We have, in the roasting of blende, the following reactions:

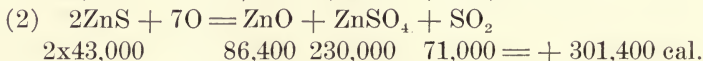
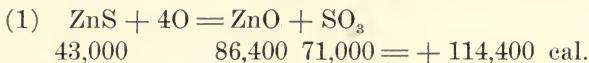

Thus in an oxidizing flame, blende is roasted to oxide and sulphate, both reactions being exothermic. As indicated in the reactions given in the chapter on roasting, pyrite or chalcopyrite assists in the reactions. At a cherry-red heat the zinc sulphate is decomposed into basic sulphate ($3\text{ZnO}, \text{ZnSO}_4$) thus:

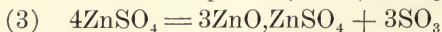

The basic sulphate, exposed to a bright-red heat for a time, reacts thus:

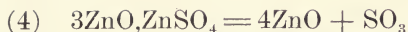

Finally zinc oxide is obtained and the sulphuric anhydride is eliminated. At a high temperature (900°C.) the latter in part decomposes into sulphurous anhydride and oxygen as follows:



When limestone or calcite is present it is converted in part to sulphate and in part to oxide. Galena also roasts to a sulphate, and tends to envelop particles of blende, and to prevent their roasting. Much of the blende from Leadville, Colorado, contains silver, and it consequently often pays to treat the retort-residues after the zinc has been removed.

There is a loss of silver in roasting that may be given at 10%, and also a loss of zinc as dust and volatilization at the final high temperature that may be reckoned at 2 per cent.

142. ROASTING FURNACES.

The roasting of blende has been performed in hand-rabbled reverberatory furnaces as well as in a great variety of mechanical furnaces. These are described in the chapter on roasting. The latter are gradually supplanting the former because of the saving of labor. It should be noted, however, that the wear is great on mechanical furnaces that have iron-work exposed to the heat because of the high final heat needed in blende-roasting, and consequently the types of furnace have been preferred where the rabble is exposed but a short time to the action of the fire, and where iron parts are not exposed or can be water-cooled.

Thus, the Brown horseshoe furnace, where the rabble is drawn through a circular hearth, then allowed to cool, or the Wethey furnace, where the rabble is exposed to the fire but half of the time and the moving iron parts are outside the furnace, have been successfully used in blende-roasting. Of the recent types, the Hegeler furnace as used by the Matthiessen & Hegeler Co., La Salle, Illinois, and by the U. S. Zinc Smelting Co., Pueblo, Colorado, has proved most successful for the above reasons. It is a multiple-hearth furnace closed by swinging sheet-iron doors at the ends, and stirred by rabbles drawn quickly through the furnace by means of rake rods, so that the parts are outside the furnace most of the time, and no iron parts, except the end swinging doors, are affected by the fire. The hearths being superimposed make a compact furnace, and the radiation is greatly lessened, so that there is economy of fuel. A 75-ft. hearth Hegeler furnace roasts 48 tons of blende in

24 hours, yielding 40 tons of roasted ore. The raw ore contains 30% sulphur, and the final roast 1.2%. The consumption of coal is approximately 20% of raw ore.

143. THE SMELTING OR DISTILLATION OF ROASTED ZINC ORES.

The recovery of zinc from the ore consists in distillation of the roasted ore in refractory clay retorts after intimately mixing it with 40 to 50% the weight of fine coal. The whole is brought to a white heat which is maintained during an entire day.

Before ore and coal are charged into the hot retort the mixture is moistened for convenience in charging, the water promptly being driven off by the heat. The light hydrocarbons of the coal come away next; then the iron oxide is reduced to protoxide and part of it to a porous iron or iron sponge. The final reaction is the reduction of the zinc oxide of the ore by the carbon to metallic zinc. The reaction commences at 1060°C., but practically a temperature of 1300°C. is reached.

In the United States the Belgian system of retorting is chiefly used. The retorts 4 ft. long by 8½ in. inside diameter are set horizontally in the hot furnace. The retort and charge being poor conductors of heat, 1.5 to 2 hours is necessary for the heat to pass from the hot exterior to the cold core. For ore high in iron, the furnace in that time becomes heated to a uniform temperature (1020°C.) and the iron oxide is reduced. If the heat rises above this point rapidly, the reduction of the oxides of iron and zinc occurs simultaneously and the CO and CO₂ gas resulting from the reduction of the iron oxide tends to sweep the zinc-vapor through the condenser, and cause it to burn at the mouth. There is a difference in the reductibility of iron-bearing blende, so that a hard ore, difficult to roast, is naturally more difficult to reduce than a porous one that has been roasted at a low temperature. If, as sometimes happens, a zinc ore is roasted at so high a temperature as to form an incipient slag, especially an iron silicate, the reduction of the ore is retarded. The iron silicate collecting at the bottom of the retort attacks other bases and quickly cuts a hole through the retort. The iron sponge, where formed, is not, however, detrimental, but where sulphur is still left in the ore, it may combine with it to form iron sulphide thus:

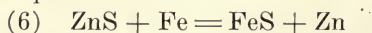

The zinc is released, it is true, but the iron sulphide formed at 1100° to 1200°C. is corrosive in action upon the retort.

When the content of the retort has been brought to the reduction temperature for zinc oxide we have:

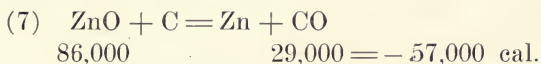

Thus the zinc oxide is reduced by carbon to zinc vapor with the formation of carbon monoxide. The carbon monoxide escaping from the mouth of the condenser, burns with a characteristic light blue flame, masked, however, by a small amount of zinc-vapor that escapes and burns at the same time.

Any undecomposed ZnS, left in the roasted ore, remains as such unless iron sponge is formed to reduce it as above described. Zinc sulphate is reduced to sulphide according to the following reaction:

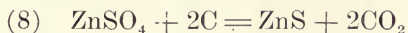

In the presence of an excess of carbon the carbon dioxide may be changed to carbon monoxide thus:



If, however, any dioxide remains unreduced, it tends to oxidize the zinc vapor back to zinc oxide, which then escapes from the mouth of the condenser and is lost.

Lead sulphate, or oxide in roasted ore is reduced to metallic form and remains in part in the residue of the retorts and in part is volatilized and condensed with the zinc, contaminating the spelter. Cadmium oxide is present to the extent of a few tenths of a per cent in certain zinc ores. It is more volatile and easily reduced than zinc oxide, and condenses with the first of the zinc. It has been known to be present in spelter to the extent of 0.5%, but usually there is but a trace. It has not been found injurious to spelter. Silver and gold remain in the residue after retorting. In Missouri, where there is little or no precious metal, the residue is thrown away, but Colorado ores, carrying silver and gold, yield residues suited to further treatment, in the blast-furnace, for the extraction of the metals.

To give an idea of the result to be expected from roasting and retorting an iron-bearing blende we take the following: A charge consisted of roasted ore containing Zn 44.8%, Pb 4.7%, Fe 18.0%, CaO 1.1%, MgO 0.7%, SiO₂ 6.0%, and S 2.9%. It was retorted in a charge of 60% ore and 40% fuel for 24 hours, and there resulted 35% of residue computed on the total charge. The residue contained 0.73% Zn, 24.2% Fe, and 4.07% S, and of the total zinc, ~~X~~95% was ~~retained~~ *recovered*. Where the same ore was imperfectly roasted and contained 7.7% S, it was found that 6.7% Zn was lost in the residue.

This shows that within commercially profitable limits, too much care cannot be exercised to effect a good roast. Now according to the rule stated in the chemistry of roasting, the loss should have been 15.4% Zn. We must accordingly infer that the greater extraction of zinc is due to the reducing effect of the iron present reacting on sulphates and sulphides containing zinc.

144. THE ZINC FURNACE.

Fig. 165 and 166 represent, in transverse section and in front elevation, a Western zinc-smelting furnace after the Belgian system,

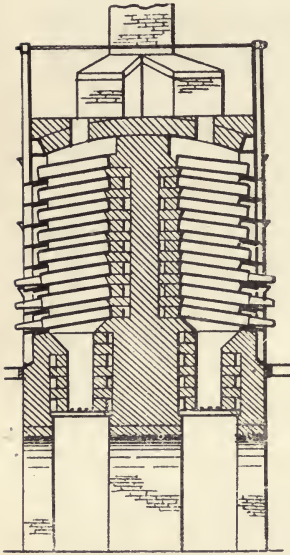

Fig. 165. ZINC-SMELTING FURNACE (SECTION).

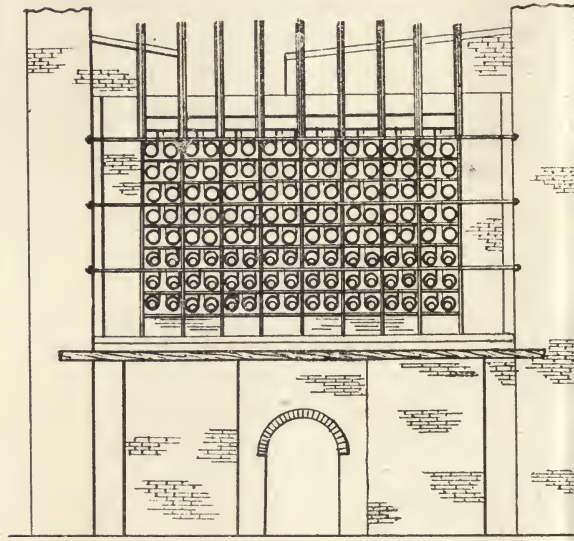

Fig. 166. ZINC-SMELTING FURNACE (ELEVATION).

for the distillation of roasted blende. It contains 265 retorts, or 128 on each side. As shown in the transverse section, there are 8 rows of retorts, the rear ends of which rest on the middle wall of the furnace. The front ends rest on the front walls. Beneath the retorts are the fire-places, each 18 in. wide by 8 ft. long, two under each bank of retorts. These are fired from the four end-doors. Bituminous coal is used, the fire-bed being 4 ft. deep, so that the coal is burned with a long flame that completely fills the interior of the furnace and surrounds the retorts. The products of combustion pass through outlet-ports in the roof to one of the two stacks, one at each end of the block or 'massive' of the furnace. Beneath

the grates ample room is left for a man to work, and with a long bar, to 'grate' or clean the fires, removing the clinker and ashes as they form. Two or three fire-bars, each 2 in. square, sustain the fire. This underground passage also serves for a tram-car in which the ashes are carried away, and the residue from the retorts removed. The end fire-doors have the sills at the ground level, 2 ft. below the lowest retorts. In Fig. 141 and 142 only the three lower rows of retorts shown are provided with condensers. In full action all are so provided. The block proper is 14 ft. high, 24 ft. long, and 12 ft. from face to face. The stacks or chimneys are 45 ft. high, one for each side of the block.

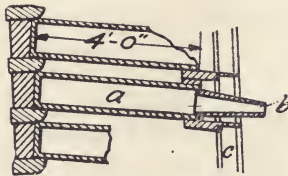

Fig. 167. ZINC-SMELTING RETORTS.

Fig. 167 shows in detail a zinc-retort in place in the furnace. It is made of fire-clay, 4 ft. long by 8.5 in. diam. and with walls 1.25 in. thick. In the figure *a* is the retort, which rests on a ledge on the rear wall of the furnace and extending just through the thin ($4\frac{1}{2}$ -in.) front wall. The wall is held by buck-staves *c* which carry the tiles upon which the retorts rest. The whole is firmly bound together with tie-rods. When the retort has been charged, the clay condenser *b* is set in place, in which the zinc vapor issuing from the retort is to condense. As seen in the front view, the space between two buck-staves is divided by shelves which form 'pigeon-holes,' each of which contains two retorts. The retorts having been set in place, the opening around them is bricked up with pieces of brick and with clay. When a retort becomes cracked or otherwise useless, it can be readily removed by breaking away the temporary wall and another retort set in the place without disturbing the adjacent retorts.

145. OPERATION OF THE FURNACE.

The roasted ore is thoroughly mixed with fine coal upon the floor of the retort-house with shovels, or better in a horizontal pug-mill, using water to dampen it. The charge for a retort consists of 60 lb. ore and 40 lb. coal, and is skilfully and rapidly

thrown into the retort, empty from the last charge and already red hot, using the special scoop shovel, Fig. 168, and filling it clear to the back. An iron rod is now run in along the top of the charge to form a channel for the escape of the gas, and the condenser *b*, Fig. 167, a conical clay tube 2 ft. long is adjusted with a piece of brick to sustain it in the exact position. The joint

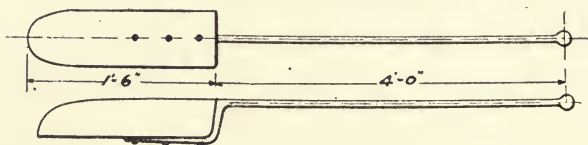

Fig. 168. CHARGE SCOOP.

between the condenser and the retort is luted with a loamy clay. To make the joint tight, a crescent-shaped 'stamper,' Fig. 169, is used, by which the loam is compressed and the joint made tight around the condenser. The tool, before using, is heated to dull redness in one of the lower rows of retorts, called 'cannons.' These cannons are not used in retorting, being left in place to modify the direct intense heat of the fire below.



Fig. 169. STAMPER.

The retorts are now charged and brought up to a white heat (1300°C.), the temperature in the retort being about 100° lower than that outside. As the charge becomes heated, the moisture and volatile gas come away, reduction of the iron takes place, and finally, the zinc oxide is reduced to zinc vapor, coming away together with the CO formed at the same time, and the reactions take place as already shown. The zinc vapor, escaping from the charge by its own tension, enters the cool ^{retort} and liquefies by being cooled below the boiling point. In practice the temperature in the condenser is 550°C. The end, or mouth, of the condenser, which is about 2¼ in. diam. is loosely plastered with a handful of the charge-mixture. From time to time (four times in

the 24 hours) the accumulated zinc is scraped into a ladle held below the mouth, with a button-headed scraper. The opening is at once loosely plastered up again. Toward the end of the distillation the firing is more vigorous to remove the last trace of metal. The charge is put into the retorts early each morning and is under the action of the fire nearly 24 hours. After this time, the final zinc is removed, and the men take down the condensers, breaking the joint formed between the retort and condenser, and remove each condenser to be carefully scraped out and again used.

The front layer of residue in the retort, which retains zinc, is again retorted. The rest of the content of the retort is scraped out with a suitable scraper or rabble. In Missouri it is often done by inserting a steam pipe to the back of the retort and blowing out the content. The residue is rejected if it contain no precious metal, otherwise it is smelted. The operation of charging, as already described, is at once begun, except when retorts are broken that have to be replaced.

Replacing retorts.—The average service of a retort, in good practice, is 40 charges. In the case of the block above described it would be necessary to replace six daily, though this will vary greatly from the average given. Some retorts break after a charge or two; others have a long life. Thus a retort may be corroded by iron that eventually perforates it. A retort may have a crack, or may become cracked, so that the zinc vapor escapes; and it must be replaced by a fresh one. Such an accident is indicated by the disappearance of the slight flame and smoke that generally issue from the condenser, there then being an inward current, due to the chimney-draft drawing the air through a crack of the broken retort. In such a case the charge may as well at once be removed from the retort.

Retorts are not set in place when cold, but are heated red-hot in a coal-fired annealing-furnace. A supply of them is ready in this furnace each morning for use. The old retort is first removed by breaking out the adjoining wall of the 'pigeon-hole.' The new one when needed is brought to the zinc-furnace by three men, and at once put in place. The work is hot and arduous. The fresh retort, having been set, is quickly bricked in, and is ready for charging.

A charge of 60 lb. of 60% zinc ore if well roasted contains 45 lb. zinc oxide or 36 lb. zinc, and yields but 85 to 90% of the zinc. The residue of a 100-lb. charge containing ZnO that

persistently remains in the residue, and ZnS that is completely reduced contains:

	Pounds.
Zinc sulphide and zinc oxide.....	2.5
Gangue and ash (from ore and burned coal) ..	25.0
Unburned coal (two-thirds having been used in reduction)	13.0
Total	40.5

The reduction in the total weight (100 lb.) is thus 59.5 per cent.

146. MANUFACTURE OF RETORTS AND CONDENSERS.

Retorts to withstand the high temperature and corrosive action of the charge are made of the most compact and durable material. The material consists of a mixture of 'chamotte' 'grog' or 'cement,' composed of burned fire-clay, or made from old broken retorts, fire-brick, or tile free from slag. It is ground to 3 or 4-mesh size and mixed with an equal amount of raw fire-clay. The mixing is done in a pug-mill using 10% water to form a stiff mud or 'adobe,' which is allowed to stand 2 to 4 weeks covered with wet sacking to season and to develop the plasticity. It is again put through the pug-mill, and finally made into retorts in a hydraulic retort-making machine under the pressure of 3000 lb. per sq. in. A machine of this kind makes 8 retorts per hour at a calculated cost of 50c. per retort.

The success of the retorting operation depends upon the durability of the retorts, and thus upon the composition and manufacture. Since the bases in the charge attack the retort, we either must exclude them by selection of ores, or use less silicious material in the retort mixture. A retort carrying an excess of silica is more corroded than one containing a large proportion of clay or aluminous material. On the other hand, if we increase the proportion of clay, the retort is liable to shrink and crack in making, and it is not so infusible nor as stiff as one made of a highly silicious mixture. Good air-dried clay for retorts consists of 30% Al_2O_3 , 50% SiO_2 , 15% combined water, and 5% bases.

The requirements for a good retort are: that it be made of refractory material to resist the intense heat, that it be not quickly corroded by impurities, that it be dense so as to prevent the zinc-vapor from penetrating it, that it be strong to keep the shape when loaded with the charge of ore and coal and heated to a

white heat (1300 to 1400°C.), and that it have thin walls, not to exceed $1\frac{1}{4}$ in., to permit the heat to be readily transmitted to the contents. It is evident that upon increasing the diameter of the retort the heat enters the charge more slowly, and hence we limit the diameter. The distance of 4 ft. between the supports is not exceeded because the retort would sag under the load at the high temperature.

Condensers.—Condensers are made of less refractory clay than retorts. They are not subjected to high temperature but must withstand much handling and severe treatment. They last 8 to 12 days, and cost 3 to 4c. each.

Drying the retorts.—The finished retorts are removed to a drying house and dried 6 to 25 weeks. Long drying gives better quality. They are first put into a room of ordinary temperature and kept 10 to 15 days until they can be safely handled. They then are taken to a hot-room and further dried at a temperature 30 to 35°C. until all the mechanically contained water is eliminated.

Annealing.—Before a retort can be put into the furnace it must be carefully annealed to remove the chemically combined water. Accordingly retorts are put into the annealing furnace and gradually heated, so as to be ready and at the required temperature on the morning of the day that they are to be used. As soon as they have been taken out others are put in.

147. LOSS IN DISTILLATION.

The loss varies from 10 to 25% of the contained zinc, and occurs in several ways. The residue or ashes discharged from the retorts retains 2 to 10% zinc in the form of undecomposed zinc sulphide and zinc oxide that escaped reduction. The residue is higher in zinc at the extreme front of the retort. The lower retorts in a direct-fired furnace are hotter, and hence the zinc is better expelled from them. Thus in a Belgian furnace, the residue from the upper row contains 9.15% zinc, from the middle row 4.67%, and from the lower row but 2.28%. On the other hand the retorts of the topmost row last 90 days, while those of the lowest row last only 6 days.

Since in good work the residue contains 3 to 5% zinc, it follows that the lower the grade of the ore, the greater is the percentage of loss figured on the original content. Thus, on a Joplin ore of 60% zinc, we expect a recovery of 90%, while in upper Silesia, where the ore carries 25%, but 75% is recovered. A new retort does not begin to give the maximum output of zinc until it has

been in use several days, due to the fact that the clay absorbs metal, forming zinc aluminate, an artificial zinc spinel. It imparts a deep purplish blue color to the retort, and an old retort may contain 6% or more of zinc. Zinc is lost by filtration through the walls of the retorts as a result of the porosity and chimney-draft in direct-fired furnaces. With gas-fired furnaces, in the combustion chamber there is a little pressure which is one of the advantages of gas-firing. Filtration loss is greatly diminished by using retorts made under high hydraulic pressure, and by the addition of coke-dust to the clay mixture, to make the walls of the retort dense and impermeable. The escape of zinc vapor through a cracked retort is an important cause of loss. In direct-fired furnaces the loss is indicated by the cessation of the small flame issuing from the condenser, and between firings by the white smoke of zinc oxide escaping at the top of the chimney. In a gas-fired furnace in such cases, the flame at the condenser is greater, and becomes brownish red instead of the usual bright bluish-green. The action of corrosive slags on retorts results in making small holes in them, and zinc may escape in this way before the defect is discovered. The action on the retorts is more destructive at nights when most of the zinc has come away, and the firing, especially on the lowest retorts, is severe. Retorts weakened by the action of the corrosive slag are apt to develop holes, and such retorts are said to have been 'butchered.'

When the condensers are removed, at the end of the distillation, there is a loss of the zinc-vapor still remaining, which escapes and burns to zinc oxide. The escape of zinc-vapor during the retorting is another loss, and the temperature of the condenser must be nicely regulated. If cold, a portion of blue-powder results, due to the condensation of the zinc-vapor in powder instead of in liquid form. If hot, then zinc escapes condensation and burns at the mouth of the condenser with the greenish-white flame that is characteristic of zinc. Thus the regulation of the temperature of the condenser is no easy matter. The endeavor is to maintain a temperature of 500°C. or 55°C above the ^{melting}boiling point of zinc. Escaping zinc may be partly saved by the use of prolongs or sheet-iron cones that fit over the end of the condenser. There is less advantage in using them than one would expect, since the material thus removed is in the form of blue-powder that must be re-distilled.

148. COST OF SMELTING.

We give herewith the cost in Kansas of smelting blende-

concentrate per ton of raw ore. The roasted ore is assumed to be 86% of the weight of the raw ore.

COST OF SMELTING PER TON OF DRY UNROASTED CONCENTRATE.

	Coal.		Natural gas.	
	Hand roast- ing.	Mech. roast- ing.	Hand roast- ing.	Mech. roast- ing.
Labor (except for repairs and renewals).....	\$6.62	\$5.82	\$4.70	\$4.25
Fuel (3 tons at 75c.).....	2.25	2.25
Reduction material (\$1 per ton).....	0.47	0.47	0.60	0.60
Clay for retorts, condensers, etc., at 0.1 ton, per ton of ore.....	0.26	0.26	0.26	0.26
Repairs, renewals, and sundry supplies (in- cluding starting furnace in operation)....	0.75	0.75	0.75	0.75
	<u>\$10.36</u>	<u>\$9.56</u>	<u>\$6.31</u>	<u>\$5.86</u>

In the above table the assumption is made that the gas (natural gas being used) costs nothing. Since we have to meet the cost of acquiring the land for natural gas and that of pipe line, etc., additional cost for gas must be allowed.

149. THE SADTLER PROCESS.

To counteract the corrosive action of the bases already referred to, Prof. Benjamin Sadtler patented a process that consists in lining the retort with basic material, preferably chromite, making a layer on the interior of the retort $\frac{1}{8}$ in. thick. The chromite is crushed to pass a 20-mesh screen and the dust is screened out, leaving a coarse granular powder. The interior of the retort is painted with a solution of water-glass, and while wet, sprinkled with the powder, in the same way that a house is painted and sanded to imitate stone. When the first coat is dry another is put on, the two coats giving the required thickness. The further drying and annealing is done as in making regular retorts. The lining fuses to the interior surface of the retort, and doubles the life (making 80 days), so that the retort fails by cracking, or by gradually accumulating residue rather than by corrosion. The retorts are especially adapted to treating ore containing iron and lead (such as the Leadville ores). The residue, still retaining the precious metals as well as lead and the excess of iron, is a desirable product for silver-lead smelting. The cost for putting in the lining is estimated to be 25c. per retort.

The retorts have been used at the works of the Cherokee-Lanyon Spelter Co., in eastern Kansas, where Colorado ores, containing iron and lead, are successfully treated.

PART IX. REFINING.

PART IX. REFINING.

150. PHENOMENA UNDERLYING THE REFINING OF METALS.

It is found in analysis that the separation of a metal from other metals or from contained impurities is seldom complete. It is difficult and commercially impracticable to obtain metals entirely pure, so that metals that come on the market still contain small amounts of impurity. Metals thus prepared are graded according to quality, and command prices according to the grade. Thus Lake copper commands the highest price of copper because of the purity and toughness, while casting-copper, which sells at $\frac{1}{2}$ c. less per pound, is used for making brass.

In silver-lead smelting practice the slag, no matter how thoroughly settled and separated from the matte, still contains 0.2 to 0.3 oz. silver per ton and 0.3 to 0.4% lead. In copper refining, in the reverberatory furnace arsenic, antimony, and bismuth, occurring in the crude or blister copper, are retained in traces after refining, and where the blister copper is impure, no high-grade product can be expected. In the separation and deposition of copper by electrolysis at low current-density, the copper is of high grade even though impurities are in solution in the electrolyte; nevertheless traces of impurity find their way into the cathode copper, though to less extent than by any other system of refining.

In the refining of pig-iron to make steel, in order to obtain satisfactory quality, impurities must be removed until not more than 0.10% phosphorus and 0.05% sulphur are present, otherwise the steel lacks toughness and tenacity.

151. REFINING LEAD BULLION.

Lead containing silver, commonly called base-bullion, is refined by the Pattinson or by the Parkes process. Commonly the Parkes process is used. The object in either process is to effect the separation of the silver and gold from the lead.

To get a clear idea of the principles of refining base-bullion (or work-lead as it is called in Europe) we first must know the

composition. An especially base quality is represented by the following analysis:

Lead		Per cent.
		96.59
Impurities: Cu		Per cent.
As		0.82
Sb		0.38
Fe		0.71
S		0.02
		0.14
		2.07
Precious metals: Ag (322 oz. per ton)		1.07
Au (0.20 oz. per ton)		0.0007
		1.07
		99.73

It is seen that base-bullion is principally lead. The problem is to soften the lead by removing the impurities, and then to separate the gold and silver from the purified or softened lead. In studying the process, the student should refer to Fig. 170.

152. SOFTENING.

The furnace.—Softening is performed in a water-jacketed reverberatory-furnace, Fig. 171. The rectangular hearth of the furnace, 7 by 14 ft. in size, is surrounded by a sheet-steel double water-jacket, shown in section at *a* in the sectional elevation, *c*. The jacket resists the action of the molten litharge formed from the lead in the operation. The furnace is heated by the fire-box, having a grate 4 by 5 ft. in dimensions, so that a high temperature can be attained in the furnace. The letters *c, c* indicate the rear working doors and *b, b, b* the front doors in which the base-bullion is charged. At the front of the furnace the tap-hole *e* is provided, through which the lead is tapped when the charge is finished. The furnace communicates to a stack 50 ft. high by a flue at the front end.

Operation.—The work is done in two stages. In the first stage at a low temperature, the copper is removed. In the second, at a high temperature, the arsenic and antimony are expelled, after which there is left only the softened lead containing the precious metals.

The base-bullion, in charges of 30 tons, is placed in the furnace by means of a long-handled paddle or 'peel' having a blade 2 ft. long by 6 in. wide. The bars are laid one at a time upon this and placed as desired in the furnace being piled in a heap on the hearth. The doors are closed and the bars are gradually melted down, the dross contained in the bullion rising to the top. When melted the heat is maintained slightly above the melting point,

(especially important) most of the copper of the base-bullion. The removal of these completes the first stage of the process. The liquated dross thus skimmed, which may amount to 5% of the charge or 1.5 tons, consists of Pb, 62.4%; Cu, 17.97%; Ag, 0.17% (49 oz. per ton); As, 2.32%; Sb, 0.98%; Fe, 0.43%; S, 4%; and O, 1.87%. Slag, ash, and hearth material also are contained and must be reckoned in.

The heat of the molten bath is now raised to a bright red; and

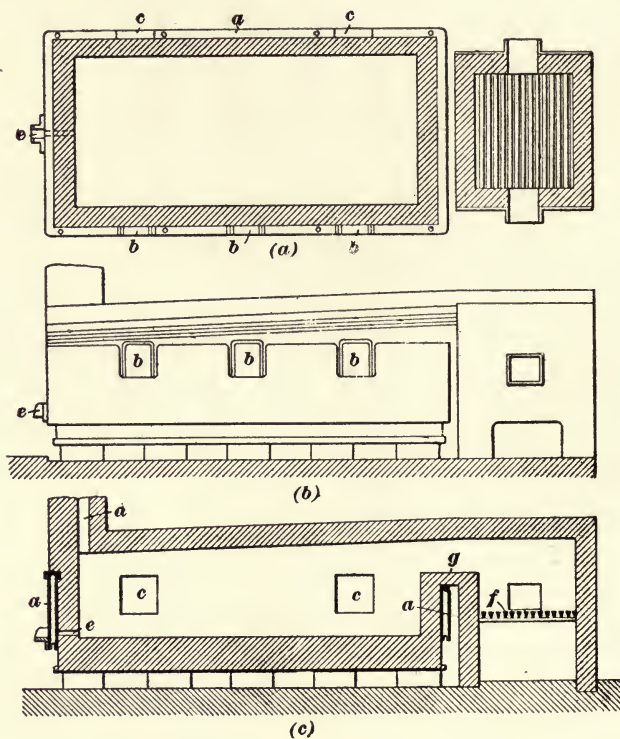

Fig. 171. SOFTENING FURNACE.

the flame, made oxidizing by the admission of an excess of air through the thin fire, sweeps over the surface. Litharge forms, and the antimony and arsenic oxidize and enter the litharge slag. The litharge at this temperature has a corrosive action upon the brick lining, hence the need of a water-jacketed furnace. This stage of the process lasts 12 hours, until a sample of the lead taken from the furnace and placed in a mold and skimmed, shows by the appearance that it is free from arsenic and antimony. Before

the antimony is removed the surface of the molten lead will 'work,' or show oily drops moving upon it. A similar phenomenon is seen in the first stage of cupelling base-bullion high in antimony and arsenic. As the softening proceeds the drops become fewer and smaller, and finally a coating is seen to dull the surface of the hot molten lead, indicating the completion of the softening. For impure base-bullion this stage is of more than 12 hours' duration, and the thick layer of litharge formed retards further oxidation. It is best then to draw the fire and to cool the charge, to allow the litharge slag on the top to solidify above the liquid lead beneath. The slag is skimmed with a long-handled perforated skimmer (compare with Fig. 175), and the charge is fired again if necessary until the impurities are removed. The 'antimony skim' consists of the antimonate and arsenate of the lead with a large proportion of litharge. It is in fact an impure litharge.

The softened lead to be treated either by the Pattinson or the Parkes process for the removal of the contained gold and silver, is now tapped into the desilverizing kettle, 8 ft. diam. and capable of holding 30 tons of lead.

153. THE PATTINSON PROCESS.

When a kettle containing molten lead is allowed to cool slowly, as it approaches solidification, crystals of lead low in silver separate. The metal that remains liquid contains the larger part of the precious metal. The crystals are removed with a perforated ladle, melted in another kettle, and allowed to cool. Once more, crystals separate that are low in silver, the mother liquor becoming high in silver. If the liquid portion first mentioned be transferred to a kettle and likewise heated and then allowed to cool, the same segregation of the silver into the liquid part continues. We can accordingly arrange a series of kettles containing, at one end, low-grade lead, and at the other high-grade, all from one product. A series of this kind, as illustrated by practice at Eureka, Nevada, gave the assays quoted in the table below.

Another crystallization would reduce the silver of the market lead to half the value given. The rich lead could be directly cupelled in an English cupelling furnace, or better, treated by the Parkes process to get rich silver-zinc crust for retorting and cupelling. The process has been modified recently by Tredennick who raises each kettle by hydraulic power above the adjoining one so that the mother liquor drains from one kettle to the next through

a strainer, the lead being cooled near the solidification temperature by introducing steam upon the surface. The cost of operating has been greatly decreased in this way. The chief advantage of the Pattinson process over the Parkes is that it gives a product free from bismuth. In the Parkes process the bismuth follows the lead. Bismuth is injurious in lead that is to be corroded to make white lead, and it may be necessary to employ the Pattinson process for making a corroding lead from bismuth-bearing ores.

Kettle	Market Lead oz. Ag per ton.
No. 1	1.25
No. 2	2.5
No. 3	5.0
No. 4	9.0
No. 5	18.0
No. 6	30.0
No. 7	50.0
No. 8	75.0
No. 9	100.0
No. 10	150.0
*No. 11	450.0

*Rich Lead.

154. THE PARKES PROCESS.

Operation.—The softened lead from the softening furnace is tapped into a hemispherical cast-iron kettle, shown in Fig. 172 and 173, which holds 30 tons or more of lead or the full charge from the softener. The kettle is set in brick-work, and is heated from a fire-box below. In modern practice kettles are made large and are 10 ft. diam. and 2-ft. 10 in. deep, holding 60 to 65 tons.

The principal of the separation of silver from lead depends on the affinity of silver for zinc which is greater than for lead. Upon adding and thoroughly mixing in a small amount of zinc (~~1% of the whole~~), the zinc takes up most of the silver. Zinc has a greater affinity than lead not only for silver but for gold and copper. When the molten bath is allowed to stand a while, the zinc being lighter separates and rises to the surface. At a temperature below the melting point of zinc but above that of lead, a crust forms that can be skimmed off. Thus the silver is concentrated in a small bulk of metal, and is later separated from the rich metal by further treatment.

The lead from the softening furnace flows along a cast-iron trough to the kettle. ~~Another crystallization could reduce the silver of the market~~ trough to the kettle. In so doing a litharge dross, called 'kettle dross' forms, and collects on the surface of the metal, and is skimmed off.

The molten bath is next heated to an incipient red heat, well above the melting point of zinc and cakes or ingots of spelter equal to about 1.2% of the weight, or 720 lb. are added. The quantity required varies with the richness of the base-bullion in silver. The added zinc quickly melts.

Desilverizing machinery is now much used. The most approved machine is the Howard, used both for mixing and skimming. Fig.

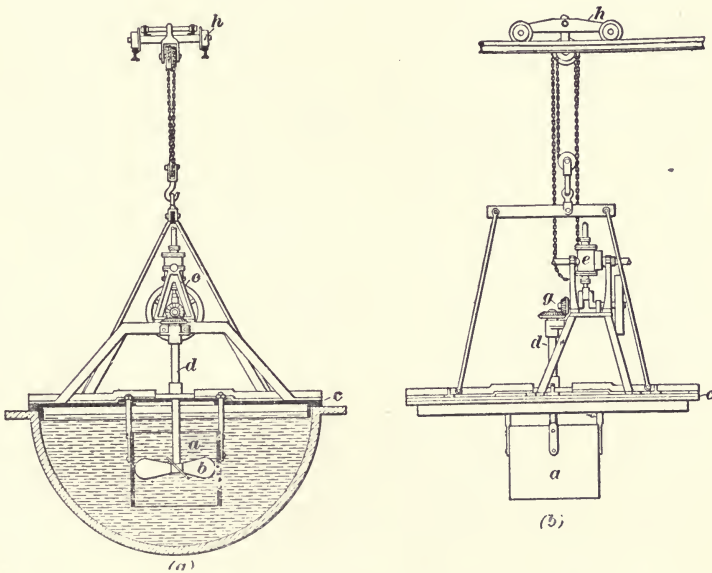

Fig. 172. HOWARD MIXER.

172 represents, in section and elevation, the kettle and the apparatus used for intimately mixing the molten zinc with the lead. The machine is brought to the kettle by an overhead crawl *h* and is lowered into it by a chain-block hoist. When lowered into position (shown in section Fig. 172) the screw propeller *b* is set in motion by a steam-driven mechanism to produce a downward flow of molten lead in the sheet-iron cylinder *a*. The cylinder has neither top nor bottom, and being submerged in the lead, a circulation is started, the lead flowing in over the top of the cylinder. Thus a

thorough mixing of the content of the kettle is assured. In a few minutes the engine is reversed, and the flow is made upward over the edge of the cylinder, then downward to the bottom. The mixing

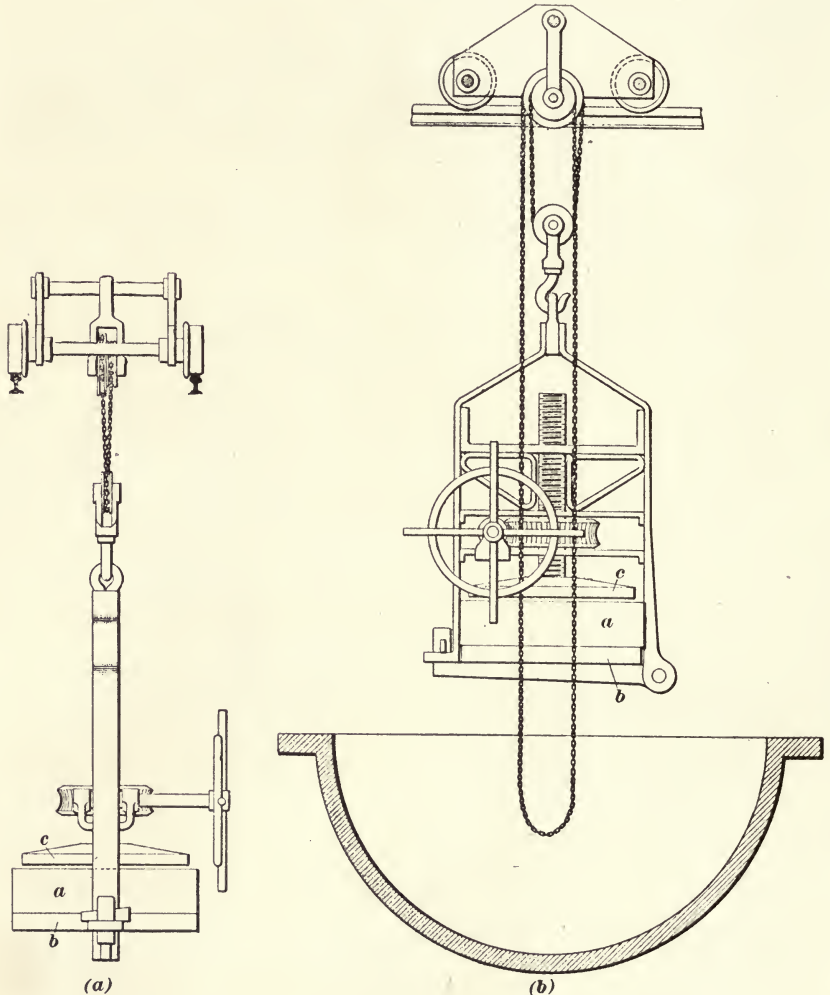

Fig. 173. HOWARD PRESS.

Fig. 174. HOWARD PRESS (SECTION).

is continued about 11 minutes, after which time the stirring apparatus is bodily hoisted and moved to one side. Several kettles can be thus served by one mixer.

The content of the kettle is now allowed to cool two hours or

more. The light zinc rises to the top and carries the silver, gold, and copper with it. Finally when the temperature falls below the melting point, a half-fused, mushy crust or layer forms upon the lead. The crust consists of 65% Pb, 10% Ag and Au, 3% Cu, and 22 to 24% Zn.

Fig. 173 is an elevation of the Howard press by which the zinc crust is removed from the lead. Fig. 174, another elevation, shows also a section of the cast-iron pot into which the press is about to be lowered. In principle the machine is like a cheese-press. The apparatus is lowered into the lead until the top edge of the cylinder *a* is but slightly above the surface. The plunger or follower *c* is raised, and the zinc-crust, as it is skimmed from the surface, is put in it by means of the perforated skimmer, Fig. 175.



Fig. 175. SKIMMER.

The press thus expedites the skimming. While one man is skimming and putting the skimming into the press, another assists by pushing the crust to one place with a wooden rabble. When full, the press is raised and the surplus lead begins to run out of the half-inch holes in the hinged bottom *b*. The plunger *c* is brought down, squeezing out more of the lead, and leaves the remaining, mushy half-fluid mass nearly free from lead, of the composition given above. The press is now run to one side over a floor paved with cast-iron plates, the hinged bottom *b* is dropped by releasing the catch, and the zinc-crust is pushed out by continuing the downward movement of the plunger. The crust falls upon the cast-iron floor-plate, and while soft is readily broken with hammers into lumps the size of the fist. Meanwhile the hinged bottom is closed, and the press returned to the kettle and is opened to receive more skimming. These operations continue until the surface of the lead is well skimmed. The crust amounts to 3000 lb. and contains 90% of the silver originally in the softened base-bullion, resulting in a concentration of twenty into one.

This first 'zinking' removes all the gold and copper for which zinc has a great affinity. It does not remove all the silver, and the operation must be repeated once or twice more before the silver

content is diminished to the fraction of an ounce per ton beyond which it does not pay to go. Of the 1.8% zinc needed, first is added $\frac{2}{3}$ of the zinc or 1.2%, then $\frac{1}{4}$, or 0.45%, and finally the remaining $\frac{1}{12}$, or 0.15%; or 900, 270, and 90 lb. respectively.

The desilverized lead remaining in the kettle after the last skimming retains 0.6 to 0.7% zinc and traces of arsenic and antimony, all of which must be removed before the lead is suitable for market. This is done by siphoning or tapping the metal from the kettle into a reverberatory furnace similar in construction to the softening furnace. Here the charge is brought up to a bright-

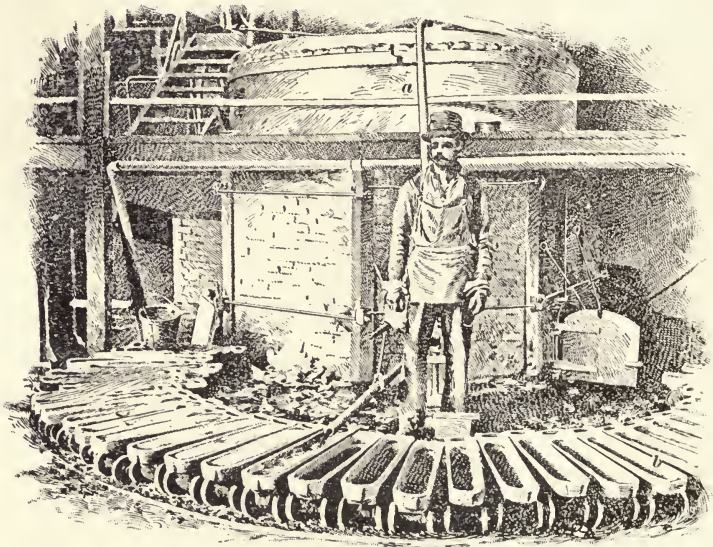

Fig. 176. MOLDING MARKET-LEAD.

red heat, the zinc is volatilized and burned off, and litharge forms as a slag upon the surface of the lead. The operation takes six hours, and the completion when the zinc has been expelled, is known by taking a sample of lead in a mold and observing the appearance of the surface as the metal solidifies. The furnace is allowed to cool until the litharge-slag is solid and can be skimmed.

Finally the lead is tapped into a market-kettle similar to the desilverizing kettle. This is the reservoir from which it is drawn to be cast into molds. The molds, 50 in number, standing in a semi-circle as shown in Fig. 176, hold 100 lb. of lead each, and are conveniently mounted on two wheels by which, when full and cool, they are transferred to the adjoining floor. There the lead is tilted

out and the molds at once returned to the semi-circle to be used again. The lead is withdrawn from the kettle by means of a siphon. It descends into a small cast-iron pot, into which is screwed the $2\frac{1}{2}$ -in. pipe that delivers it to the 50 molds, the pipe being quickly moved from mold to mold as filled, without interrupting the flow.

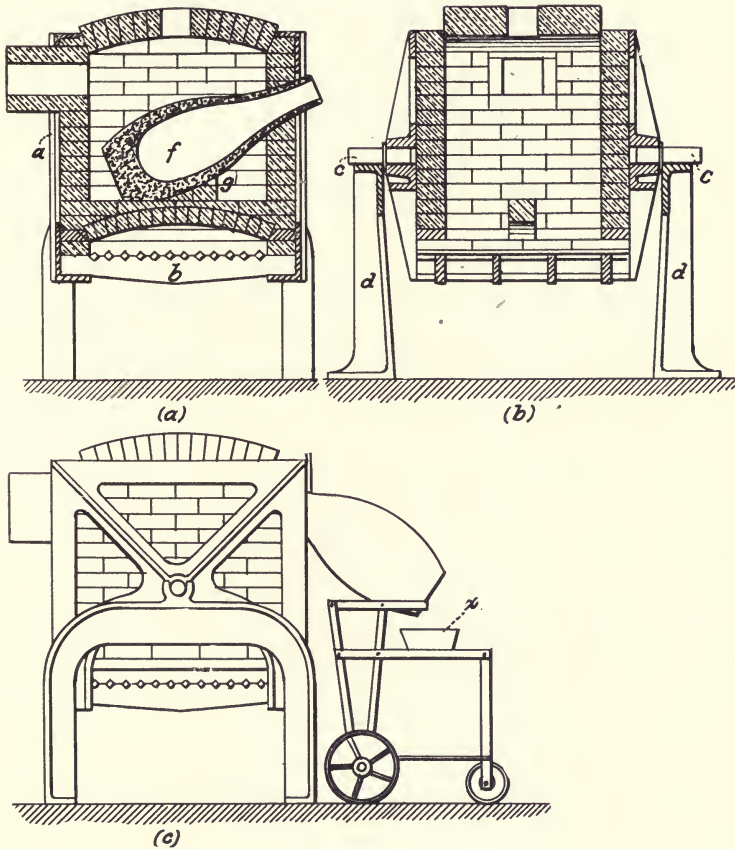

Fig. 177. FABER DU FAUR RETORT.

At the end of each round the flow is interrupted only to carry back the end of the pipe to the first mold of the series, which meanwhile has been emptied and replaced. The 100-lb. pigs, or bars, are the desilverized lead of commerce.

Dry steam may be blown into the molten lead in the kettle to refine it. It is introduced by means of a pipe inserted deep beneath the surface. The constant agitation produced by the steam brings

the metal in contact with the air and oxidizes it and the remaining impurity. It is softer than ordinary desilverized lead, and is easily corroded by the acetic acid used in making white lead. It is accordingly called 'corroding lead.'

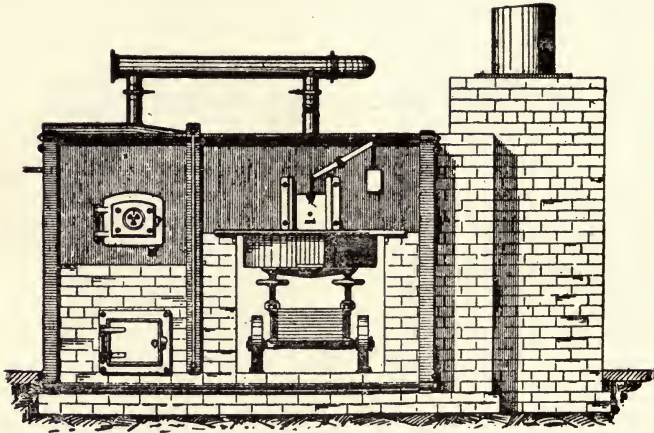

Fig. 178. ENGLISH CUPELLING FURNACE.

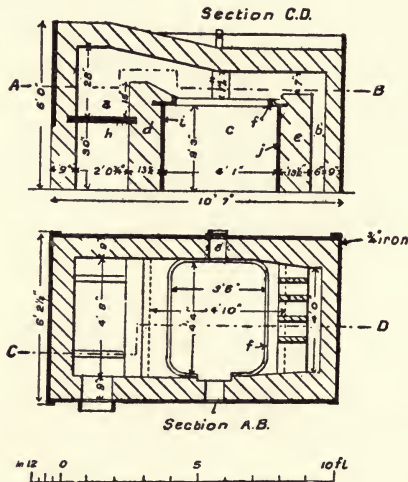

Fig. 179. ENGLISH CUPELLING FURNACE (DETAILED SECTIONS).

Retorting.—Referring to the flow-sheet (Fig. 170), we see what becomes of the crust or skimming that results from the first zincing. The material is in lumps, containing 22 to 24% zinc. It is charged with charcoal breeze, into bottle-shaped retorts *f*, Fig. 177,

each holding 1200 lb. zinc-crust. The figure represents at *a* a sectional elevation through the retort, at *b* a transverse section, and at *c* an elevation of a Faber du Faur tilting retort-furnace. The retort rests upon a narrow arch, and carries a grate upon which rests a coke fire that fills the furnace and covers the retort *f*. The products of combustion escape by an outlet-port at the back to a stack of good draft. The coke is fed through a hole in the roof of the furnace, and is poked down, and kept in vigorous combustion, so that a yellow heat ($1000^{\circ}\text{C}.$) is attained. A condenser, made by cutting off the end of an old retort (as shown at *c* Fig. 177), collects the zinc vapors distilling from the charge, the condensed zinc being drawn into molds *x* through a one-inch hole, bored through the bottom edge of the condenser. When distillation is complete, the condenser and the supporting truck is removed, the furnace is tilted or revolved by means of a lever on the trunnions, and the remaining 'rich-lead' is poured into molds like those used for molding market-lead. The rich lead still retains zinc, copper, and impurities, taken into the crust at the first zincking.

Cupelling.—To obtain the silver (and gold) from the alloy, the English cupelling-furnace, Fig. 178, 179, is used. The principle of the action is much like that of cupellation in assaying, except the litharge here not only saturates the cupel, but flows from it as fast as formed. Fig. 179 is a sectional elevation of the furnace, showing the fire-box *a* where a long-flaming coal is burned, the products of combustion passing to the chimney by the port *b* and an underground flue. The flame plays over the hearth called a 'test,' a large cupel, not shown in Fig. 179, but shown mounted on the carriage in Fig. 178. The test is lowered by the jack screws, removed on the carriage, and another is put in, when the first is consumed. The test is hollowed like a cupel, to hold a shallow bath of molten lead 3 in. deep. Fig. 180 shows two views of the test and the supporting truck including a view of an inverted truck and test. In the elevation of the furnace, Fig. 178, is seen the overhead pipe, branching to the ash-pit, to supply undergrate-blast, and to an opening at the back of the furnace where a tuyere is inserted, by which a stream of air is brought to play upon the surface of the molten red-hot bath of rich lead. The air oxidizes the lead to litharge. Other impurities are oxidized and enter the litharge-slag and are carried away with it. The molten litharge, as it forms, runs along a shallow groove or channel in the top of the front edge of the cupel or test. A door at the front can be lifted to inspect the operation, or to cut the channel as needed. At the rear are

provided two ports of a size to permit inserting two bars of rich lead that are pushed in as fast as the cupellation proceeds. The ends of the bars melt and supply the lead. The litharge stream is the size of a lead pencil, and falls into a small slag-pot beneath. The lead is fed at the rate of one to two tons daily until the bath has become rich in silver, when the feeding of the lead must be stopped. Oxidation then is continued, cutting the channel deep to allow the remaining litharge to flow out, and finally the mirror-like bath of silver appears. The fire must keep the temperature above the melting point of the silver. At the last, a shovelful of bone-ash is thrown on the bath to absorb the remaining trace of litharge as it forms on the surface. This is skimmed, and the silver is then ready to be ladled out or tapped, commonly into cast-iron molds each holding

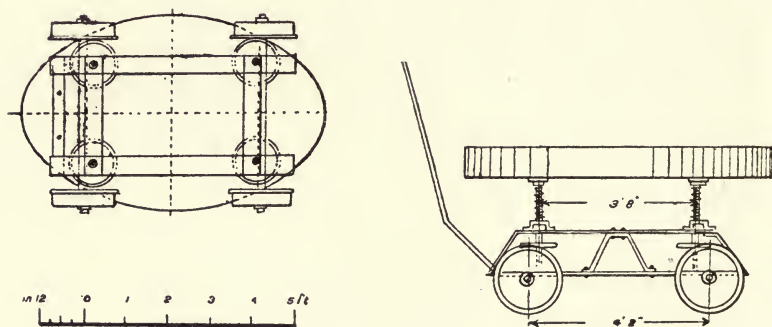

Fig. 180. TEST FOR ENGLISH CUPPELLING FURNACE.

1000 oz. silver. The silver is then subjected to the acid-parting operation to be described later.

The copper-skimming, which is the first obtained from the softening furnace, is returned to the blast-furnace where the sulphur of the charge combines with the copper and removes it as matte. The rest of the skimming, mostly lead, containing silver and gold, is reduced to base-bullion. The third skimming of the softening furnace, if any, is returned to the blast-furnace since it contains but little antimony.

The second softening skimming or antimony-skim, containing 15 to 25% antimony, goes to a small reverberatory furnace, 8 by 12 ft. hearth dimensions and 10 in. deep, built like a softening furnace and called a precipitating furnace. Here it is melted, with a reducing flame into a slag. Charcoal is added, and stirred, to reduce or precipitate part of the lead of the slag. The lead, falling

to the bottom of the bath, carries down the silver of the slag. When the reaction is complete the supernatant slag is tapped into slag-pots, and the lead is tapped into a kettle at a lower level and molded into bars. This precipitated lead-bullion is returned to the softening furnace to be softened and desilverized. The antimonial slag, containing about 6 oz. silver per ton, when accumulated, is smelted in a small blast-furnace to reduce it to antimonial lead of 20% Sb, which is sold to the type founders. The slag is rejected.

155. VARIATIONS IN METHODS OF REFINING BASE-BULLION.

Instead of removing the gold and silver together, in the first zinc-crust, it is possible to take the gold, copper, and a part of the silver by a separate zincking, in which a moderate amount of zinc (250 to 350 lb.) is used. The separation is due to the fact that zinc has a greater affinity for gold and copper than for silver. We thus obtain a zinc-crust containing all the copper, gold, and some of the silver. From this crust, upon retorting and cupelling, a doré bar (a silver bar containing the gold) is produced. The second zincking accordingly needs but 600 lb. zinc, and removes most of the remaining silver. A final zincking makes the lead practically clean.

The second zinc-crust yields a silver bar free from gold, on which the expense of parting is saved, and the full price of commercial bar-silver is obtained.

In the practice of early days, on clean base-bullion, made from clean ores, softening was performed in the kettle. The bars were melted at a low temperature, and the dross was made as dry (free from lead) as possible before skimming. The skimmed lead was brought to a red heat by vigorous firing, and stirred to furnish contact with the air. Arsenic and antimony were present in limited quantity and could be removed in this way. For ordinary base-bullion the method is inadequate, and the softening-furnace must be used.

When lead has been desilverized, the contained zinc can be removed in the desilverizing kettle without the use of a reverberatory calcining furnace. This is accomplished by heating the lead in the kettle to a high temperature and rabbling by means of dry steam or compressed air, admitted into the kettle through a pipe that leads to the bottom. As the steam rises it agitates the hot metal and brings it in contact with the air above the kettle. The zinc is thus in part volatilized, in part oxidized with a little

of the lead. A powdery litharge is formed that is skimmed off, leaving market lead.

In the old way of stirring the zinc into the charge of the desilverizing kettle, the work was done by means of paddles (shown in Fig. 181) having a handle 7 ft. long. Two men worked with the paddles, one on each side of the kettle. The paddle blades were

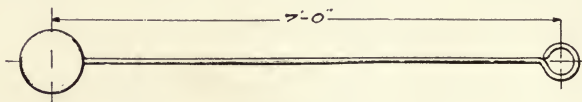

Fig. 181. STIRRING PADDLE.

moved as in the operation of rowing, thoroughly mixing the zinc into the lead in 15 minutes constant stirring.

Where the Howard press was not used, the first or silver-crust, from the desilverizing kettle, was transferred to another kettle and kept at a low-red heat. In consequence there was a separation of a liquid portion that was retained and sent to the next charge, the dry residue being the copper skimming. The bars were put into the softening furnace to complete the refining.

156. COST OF REFINING BASE-BULLION.

The actual cost of refining base-bullion is as follows:

Prime or flat-cost, of softening		
and refining	\$5.00 to	\$6.00
General expense	3.00 to	3.00
Loss in metals and incidental expenses	1.70 to	3.00
Total	\$9.70 to	\$12.00

157. COPPER REFINING.

Blister copper, or black copper, whether produced in the blast-furnace, the converter, or the reverberatory furnace, or by melting the concentrate from the native copper ore of the Lake Superior region, still contains impurity, principally arsenic with sulphur and iron, and all impurity must be removed by refining. If the copper contains gold and silver in quantity to warrant (20 to 40 oz. silver per ton), it is melted without attempting to refine, and cast into anodes that then are subjected to electrolytic refining. If there is but little precious metal in the copper it may be directly refined in the copper refining-furnace. Fig. 182 is a sectional

elevation, and Fig. 183 a sectional plan of a 40,000 to 50,000 lb. copper-refining furnace. It is 14 by 19 ft. hearth dimensions, and has a fire-box $5\frac{1}{2}$ by $6\frac{1}{2}$ ft., or 30 ft. area, and carries a fire-bed

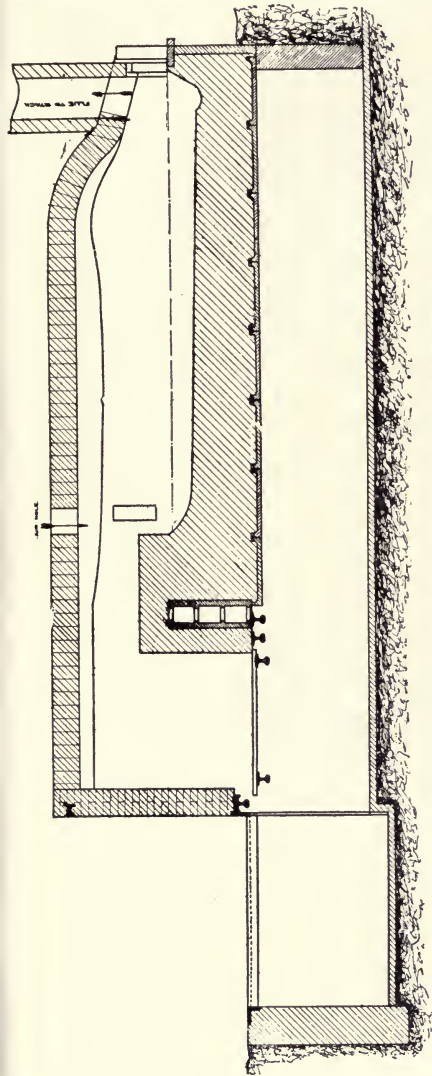

Fig. 182. SECTIONAL ELEVATION OF COPPER REFINING FURNACE.

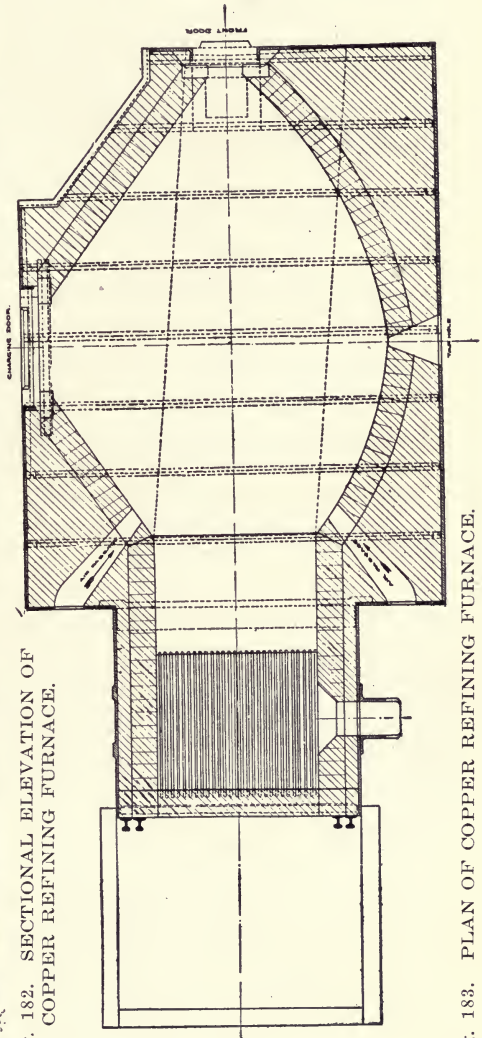

Fig. 183. PLAN OF COPPER REFINING FURNACE.

$4\frac{1}{2}$ ft. thick. The hearth, $2\frac{1}{2}$ ft. deep, has a brick or a sand bottom. If of sand, the bottom is carefully smelted in. Beneath, the hearth is vaulted for ventilation. The bridge, 5 ft. wide, is strengthened by a double conker-plate, and on either side and in the roof over the fire bridge, are ports that are opened when an oxidizing flame

is desired. In the elevation, at the front end, is to be seen the outlet-flue that leads to the stack or chimney. The chimney is close to the furnace but is not shown in the plan. The charge of ingots of blister-copper is put in at the side door. The door is then tightly closed, and vigorous firing follows. The charge melts after several hours. The front door is then opened, and whatever slag formed during the melting is skimmed.

Next follows the rabbling, the object of which is to oxidize a portion of the copper and the impurities with it. The operation years ago consisted in striking the surface of the bath with a rabble in such a way as to splash the metal and agitate it, thus exposing it to the action of the air. The present way is to insert a $\frac{3}{4}$ -in. pipe just beneath the surface of the metal and force compressed air through it to agitate, and at the same time to oxidize it. The air-ports of the furnace also are opened and the flame is made an oxidizing one. The action proceeds to the stage of 'set copper,' Cu_2O having been by this time formed, and in part dissolved in the copper. Iron, sulphur, and arsenic partly volatilize, and partly oxidize and enter the slag that is formed at the same time, this is skimmed off.

The copper oxide must be removed by poling. This is a reducing action in which the air-ports are closed to give a reducing flame, and spruce or poplar poles are inserted at the front door into the metal. The outer end of the pole is raised to force the butt-end beneath the surface of the metal. At the same time a wheelbarrow-load of charcoal is thrown in to cover the surface, to exclude air, and to reduce cuprous oxide. As the hydrocarbon of the wood is evolved and the moisture evaporates, that is as the wood burns, reduction takes place. The operation requires an hour or two. Additional poles are inserted to replace those consumed. Samples of a few ounces of the copper are removed in a small ladle from time to time and examined to note the progress of reduction. The 'tough pitch,' (the point at which the cuprous oxide is completely reduced to metallic copper) is the end in view.

The charge is now ready for dipping or ladling. Hand-ladles, holding 25 lb. or, large 'bull ladles,' holding 200 lb. and carried by an overhead trolley or crawl, are used. The dipping or molding consumes three hours. The copper is kept hot by occasional firing, and by keeping the surface of the metal covered with charcoal. The charcoal serves also to keep the copper in pitch, or in the condition of tough copper. The molds into which the copper is poured from the ladles are of the shape required by the trade. There are required; ingots or bars suited to re-melting for making

brass; wire bars of a form convenient for rolling into wire; and rectangular cakes, often 18 in. square and 4 in. thick, but also of dimensions giving 2000 to 4000 lb. weight. The size of the cake is suited to the size of the sheets of copper into which they are to be rolled.

158. MELTING AND REFINING LAKE SUPERIOR COPPER.

The product from which copper is made, in the Lake Superior region, is a concentrate (called locally 'mineral'), which averages 70% copper in native form, accompanied with a self-fluxing or fusible gangue. In addition there occur pieces of copper of different sizes, from that of the fist to several tons in weight, called mass-copper. The small pieces are handled easily, and are shipped to the smelting works in barrels. It is called barrel-work. The larger pieces called 'mass copper' or simply 'mass,' are 70% copper. For the large pieces that cannot be charged at the side doors, a hatch-opening with a clamped brick cover is provided. Large pieces are raised by a crane and charged through the hatch, also concentrate or mineral to make a charge of 36,000 to 40,000 lb. The charging takes place immediately after the dipping and the repairing or fettling the furnace.

The furnace is now closed, and firing proceeds for several hours. As the charge melts and slag forms, it is skimmed until the metal is completely melted and the surface is clear. The operation of refining then continues as has been described above. The slag contains 15 to 25% copper, partly as entrained prills and flakes, and partly as cuprous oxide. This slag is smelted in a blast-furnace with added limestone to make the resulting slag fusible, using anthracite coal and a portion of coke for fuel. The charge consists of slag 2000 lb., limestone 600 lb., and anthracite coal 400 lb., and the slag resulting contains 41% SiO_2 , 25% CaO , and 22% FeO . It is the practice at one works to add much small mass-copper and barrel-work to the charge, the idea being that as the copper melts and sinks into the crucible of the furnace in the form of drops, it carries down particles of reduced copper with it. The products of the furnace are slag, of less than 1% copper, and cupola blocks (impure blister-copper).

In recent practice in the Lake Superior country the operation of melting is performed in one furnace and refining in another. A furnace, 18 by 40-ft. hearth area melts 100 tons of mineral of 67% copper in 24 hours using 30 tons of coal. The charge is supplied in two portions, the second following as soon as the first is melted.

Slag is removed several times during the period, and the copper when free from slag is tapped into a refining furnace at a lower level. The refining is done in a 14 by 22-ft. furnace carrying a deep charge of copper. The charge is made from copper scrap, high-grade 'mineral' of over 80% copper, and mass-copper. It is melted, and when ready the charge from the melting furnace is added, so that the total charge consists of 275,000 to 300,000 lb. copper. The large quantity of copper is refined by rabbling or poling. To cast it in a reasonable time, a casting machine is employed which transforms the copper into commercial shapes at the rate of 50,000 lb. per hour.

The cupola-blocks, referred to above, which constitute the product of the blast-furnace smelting of the slag from the reverberatory refining-furnace are melted and refined to produce a low-grade copper called 'casting-copper.' The cupola-blocks are impure and contain so much arsenic that it is practically impossible to remove it all. Other impurities (iron and sulphur) are eliminated.

159. ELECTROLYTIC COPPER REFINING.

Blister-copper from reduction works in the Western States is profitably treated by electrolytic refining. Not only can a pure copper be produced from impure material, but the gold and silver in the blister-copper can be separated and recovered. The copper from the reduction works, in the form of rough ingots, is sampled to determine the content of precious metal and the copper. The electrolytic refining of copper is well illustrated in the practice of the Raritan Copper Co., Perth Amboy, N. J. Sampling is done by drilling each ingot or bar with a $\frac{5}{8}$ -in. drill, the drillings being then mixed for the sample of the lot.

The copper after being sampled is sent to the re-melting-furnace which holds 150,000 lb. copper. It is melted, poled, and cast into smooth anodes by means of a Walker casting-machine. The anodes, weighing 300 lb. each, coming from the machine, are trimmed to remove fins or projections of copper, and are loaded on trucks holding 22 anodes in a rack.

The trucks are moved to the tank-house where the anodes are picked up, and a group of 22 forms the charge for a tank. There are 420 tanks in all, each tank being in electrical connection with the adjacent ones. The current passes through each of the 22 plates or anodes to the cathodes placed between, and anodes and cathodes are 2 in. apart. Assuming that the anodes are 2 by 3 ft. in size, we have, in each tank, a total area of 264 sq. ft. through

which the current is passing with a density of 15 amp. per sq. ft. We thus have a total of 3960 amperes. The plates are immersed in a solution (electrolyte) of copper sulphate (blue-stone) in dilute sulphuric acid, the CuSO_4 being 15% (4% Cu) and the H_2SO_4 10% of the solution. The pressure in passing through this 2 in. of electrolyte to the cathode is 0.25 volt. The tanks in series would therefore give a pressure of 105 volts.

For the cathodes, so-called 'stripping plates' are prepared as follows: Certain tanks are reserved for this duty and are provided with insoluble anodes of lead plates. Opposite the anodes are inserted greased copper plates upon which a layer of copper precipitates. When the layer becomes $\frac{1}{32}$ in. thick the plates are taken out and the sheets of copper are stripped from the surface, the grease upon which prevents adhesion. Some of the sheets are cut into strips, and made into loops, and are riveted to the plates that are suspended in the regular tanks. There are 23 plates for each tank and these form the beginning of the cathodes.

One ampere deposits one ounce avoirdupois in 24 hours. Each cathode, 2 by 3 ft., increases in weight 11 lb., and all the plates of a tank 248 lb. in 24 hours. The anodes correspondingly decrease in weight and become thinner by the same amount. At the end of two weeks the cathode, now weighing 160 lb., is removed, and another starting-sheet is put in the place to receive all the remaining copper that can be taken from the anode. Not all the copper of the anode is dissolved. The part of the anode above the solution, and at least the skeleton of the plate, must remain to transmit the current. Shreds and pieces of copper drop to the bottom of the tank, and these with the fragmentary anode, still retaining 15% of the original weight, are removed, re-melted, and cast into new anodes.

Current density.—The greater the density (in amperes) of the electric current through the anodes, the more rapid is the deposition, and hence the smaller is the stock of metal that needs to be carried for a given output. At Great Falls, Montana, the current density is 40 amp. per sq. ft., while at Perth Amboy, N. J., the density is 15 to 17 amp. At high density there is a liability of short-circuiting, and the cathode-plates take on more impurity such as arsenic and antimony. It commonly takes a month to dissolve anodes. Hence in a large refinery, a half-million to a million dollars is tied up in copper and precious metals undergoing treatment.

Treatment of the slime or anode-mud.—Blister-copper, made into anodes, is commonly 97 to 98% copper. The remaining 2 to 3% is largely substance insoluble in the electrolyte. The insoluble

substance falls to the bottom of the tank, forming a thin mud, valuable for the gold and silver contained. To remove the mud the tank is by-passed. Being cut out of the system, the clear electrolyte is decanted, and the anode mud washed into a tight tram-car placed below the outlet-plug of the tank. The mud contains fragments of copper of all sizes that have dropped from the anodes when nearly dissolved. They are removed by passing the mud through a 40-mesh screen into a settling tank. From here it is drawn to a pressure-tank, then to a filter-press, and is dried by steam to 2% moisture and broken up. The broken material is then ready for treatment in an English cupelling-furnace. It is charged into the furnace on a molten lead-bath into which it melts, the lead taking up the silver and gold. The impurity in the dried material, such as copper, arsenic, antimony, and tellurium, are partly volatilized, partly absorbed by the litharge-slag that forms under the action of the air-blast used in this type of furnace. The lead having been finally cupelled, the doré silver is left and is cast into bars.

The scrap copper, screened from the anode mud as above described, is re-melted and re-cast with other anode-scrap into anodes, all amounting to 15 to 20% of the copper treated.

Another method of recovering the precious metals consists in digesting the anode mud in dilute sulphuric acid which dissolves and removes the copper.

Purifying the electrolyte.—The best proportion of acid and copper for the electrolyte is 10% H_2SO_4 and 15% CuSO_4 (equivalent to 4% Cu). When the copper exceeds this quantity, the resistance increases; hence copper is removed from the circulating electrolyte or solution if in excess, to bring the amount to the required proportion. The quantity of iron, arsenic, antimony, and tellurium gradually increases, and a time comes when the electrolyte becomes foul with them and the excess must be removed. Antimony can be kept low by the daily addition of a small amount of salt, which precipitates as an oxychloride.

To purify the electrolyte the following method is used. A portion of the electrolyte is diverted in a constant flow to tanks reserved for the purpose of purification. These have insoluble sheet-lead anodes and copper cathodes. A strong current is used so that not only is copper deposited but also the impurity. The deposit collects loosely upon the copper plates and falls to the bottom of the tanks. Every two months the accumulated mud, containing 40 to 60% copper, is cleaned out and reduced in a reverberatory refining

furnace to form impure bars of copper. The purified electrolyte is returned to the main system.

Circulation of the electrolyte.—To avoid short-circuiting, and to increase the activity and regularity of deposition, the electrolyte is made to flow or circulate through the tanks, entering the top of each tank near the end, passing downward between the plates, and finally rising and flowing away through an overflow pipe at the other end. After the solution has flowed through two tanks in this way, it enters a launder that returns it to the collecting or sump-tank. Thus every pair of tanks has an independent circulation. The sump tank receives all the electrolyte. Here the electrolyte is heated by means of a steam-coil to 40°C., the effect of the warming being to decrease the electrolyte resistance. It is then pumped up to a distributing or stock-tank, and thence once more enters the circulation.

Testing the current.—Besides the voltmeter and ammeter to be found at the switch-board in the power-house, it is customary to use a voltmeter for constantly testing the drop in potential between the anodes and cathodes. For this a forked rod is used, which touches the two plates and takes a small current through a portable voltmeter. A slight drop of pressure indicates short-circuiting.

160. COST OF ELECTROLYTIC REFINING.

In the early days of refining, costs were high (\$20 per ton), and refineries charged \$40 per ton of blister-copper treated. At present, the cost of refining 98% copper anodes has been reduced to \$4 to \$5 per ton, and contracts have been closed at \$7.50 per ton. To this cost is added the charge for re-melting, if the copper comes to the refinery in the form of ingots that need it. Anodes, wherever made, should be re-melted, since casting them directly from the converter leaves a rough and porous product that is undesirable for the electrolytic tank. The cost of re-melting is generally stated at \$5 per ton. The economy now possible is the result of cheaper power and the use of casting and handling machinery, as well as improved operation in other respects.

Capital in plant.—Not only is capital invested in the buildings and the equipment of the plant, but it is required for:

- (1) The stock of anodes in process of treatment.
- (2) The stock of anodes awaiting treatment.
- (3) The copper constantly contained in electrolyte.
- (4) The copper needed for the heavy conductors transmitting the current.

The result of this large demand upon capital is to restrict the operation of plants to places near financial centers, like New York, where cheap money is available, the copper near the market, and the labor abundant. These considerations outweigh the advantages of having the plant near cheap water-power.

161. REFINING IMPURE SPELTER.

In general the spelter, as made at the zinc furnace, is sufficiently pure and is used without refining. If, however, the ore contains lead, the spelter will also contain it, and this must be removed by refining. A small quantity of iron also remains in the spelter, and this must be removed. It is observed that the spelter first made and expelled by distillation is purer than the part obtained later, and often the first of the zinc is kept separate, molded into smaller plates, and is put on the market as a special brand.

The principle of the method consists in re-melting the spelter in a reverberatory furnace with a reducing flame, and letting the molten bath stand until the metal separates into layers according to the specific gravity of the different metals, the lower part of the bath consisting of a leady zinc and the upper part of spelter nearly free from lead. The lower layer is then tapped, or removed otherwise. The separation or refining must be done at a temperature near the melting point of zinc since the higher the temperature the more persistently does the zinc retain lead. Under the most favorable circumstances the lead-content of the spelter is reduced to 1 to 1.25 per cent.

To refine spelter, a furnace resembling that shown in Fig. 182 and 183 is used, but the fire box is in two parts and provision is made to charge the spelter close to the bridge. It holds 30 tons of spelter when full, and in it 10 tons can be refined in 24 hours. The metals separate into layers. At the bottom is the lead; the iron forms with the zinc and part of the lead a difficultly fusible alloy that floats on the lead, and uppermost is the stratum of pure zinc. By means of an iron rod inserted into the bath, layers are distinguished, the zinc being soft, the iron-lead-zinc alloy (called 'hard zinc') being mushy, and the molten lead at the bottom soft. The underlying lead is removed weekly. A cylinder or pipe closed at the lower end is sunk below the lead layer. The plug is then knocked out, and the lead, rising in the cylinder, is ladled into molds. The zinc of the top layer is ladled out daily into molds, and it retains 1 to 1.25% lead. The hard zinc layer is removed when opportunity offers. To do this the zinc is ladled out first, the lead

is next removed, and finally the mushy mass of ferruginous metal is removed with ladles perforated so that the lead drains off. This hard zinc is sold for the manufacture of Delta or Sterro-metal.

Spelter produced in the United States is generally pure and needs no refining. American high-grade spelter contains only 0.01 to 0.02% lead, and 0.01 to 0.02% iron. American Western spelter ranges from 0.4% lead and 0.02% iron in the better brands to 1% lead and 0.05% iron in the poorer.

162. PARTING GOLD-SILVER BARS.

The bars from reduction works contain gold and silver commonly alloyed with copper, but sometimes also zinc and lead. It is customary to re-melt the bars and assay them, buying them on the result of the assay.

The bars are parted in nitric or sulphuric acid. Sulphuric acid, being cheaper, is the acid commonly employed.

Bars containing a large proportion of gold are inquartated by melting them with silver in order to decrease the proportion of gold to silver ratio of at least 2.5 to 1, otherwise the acid fails to attack the silver. In parting with sulphuric acid the copper should be less than 10%, but in nitric-acid parting more than 10% is allowed. To adjust this percentage, bars low in copper are melted with those high in that metal.

Nitric-acid parting.—This method, still practised at the United States Mint, Philadelphia, is an efficient way of parting, especially on a small scale. The bars having been melted and proportioned as above described, the molten metal is granulated by pouring it into a tank of water. The granulated metal is transferred to porcelain, glass, or platinum vessels, and treated with nitric acid, 1.20 sp. gr., until action ceases. The solution is allowed to settle, then is decanted, and fresh acid is added for the purpose of dissolving the remaining traces of silver. This is again decanted, and the gold residue is washed thoroughly with hot water. It is then ladled out, drained, dried, and mixed with a little flux, and melted in a graphite crucible.

From the decanted silver solution the metal is precipitated by adding common salt. The silver chloride thus formed is washed, thoroughly granulated, zinc is added to reduce the silver to metal, and the zinc chloride resulting from the reaction is washed from the precipitated silver. The silver is pressed into cakes, melted, and cast into ingots for bar-silver.

Sulphuric-acid parting.—Since for this method of parting there

should be less than 10% copper present in the gold-silver alloy, and not less than 25 parts silver to one of gold, the bars to be parted that exceed the required limit, are so selected and melted with others as to afford the required proportion. The melted metal is cast into flat ingots and parted in this form.

The ingots are placed in a cast-iron kettle, covered with a sheet-iron hood that is connected with a chimney so that the acid fume from the kettle is carried away. Here they are treated with sulphuric acid of full strength (66°Bé). When action has ceased the solution is allowed to settle, after which the clear supernatant part is decanted, being drawn off by a lead-pipe siphon into a lead-lined precipitating tank. The residue in the kettle is treated six or seven times with fresh boiling acid. In this way the silver completely dissolves, the acid solution being removed after each treatment. The brown gold residue is finally boiled with water, being heated and agitated by live steam from a pipe inserted in the water. In this way the gold is 'sweetened.' The residue is removed from the kettle, dried, melted in crucible with a little borax for flux, and cast into a bar of gold of 999 fine.

The acid solution from the kettles, which flows to the precipitating tank, is diluted with water, and the silver is precipitated by hanging copper plates about one inch in thickness in the solution. The copper replaces the silver in the acid solution, which becomes blue in color. When precipitation is complete the clear solution is decanted, and the cement silver at the bottom of the tank is washed with hot water to remove the acid copper-solution. The 'cement' silver, or precipitated silver, is removed to a box, then pressed into cakes or cheeses in a hydraulic press. Thus compressed, it is ready for melting in plumbago crucibles after adding a little borax flux. In large establishments the silver is melted in a small reverberatory furnace where it can be conveniently fluxed, skimmed, and ladled into bars for the market. The bars weigh 35 lb. or 500 oz. each. On refining, each bar is marked with a number and the exact weight, and fineness, and the name of the refinery that produced it.

163. REFINING CAST-IRON TO MAKE WROUGHT-IRON AND STEEL.

Because of the large amount of carbon in cast-iron, it is too weak and brittle for many engineering purposes. Three-fourths of the pig-iron in the United States is made into steel or wrought-iron, about 3% being manufactured into wrought-iron. Wrought-iron is

used in preference to steel for certain purposes because of the welding quality, ductility, and toughness compared with bessemer or open-hearth steel, but for most engineering purposes steel, that now is as cheap as wrought-iron, is superior.

164. PUDDLING PIG-IRON TO MAKE WROUGHT-IRON.

In this process the pig-iron is melted in a reverberatory furnace lined with iron ore, using an oxidizing flame. During the melting there is an elimination of silicon and manganese which are oxidized in part by the flame and in part by the lining that with the silicon produces a slag. After melting, the heat is reduced and reaction starts between the iron oxide of the slag and the silicon, carbon, phosphorus, and sulphur, of the bath, whereby the impurities become oxidized and absorbed in the slag.

The removal of the impurities or metalloids leaves the metal in the state of wrought-iron, but it is so nearly infusible that the heat of the furnace fails to keep the charge molten, and the metal 'comes to nature' or becomes pasty. The puddler collects the iron in the furnace into several balls weighing 125 to 180 lb. each, that are removed, dripping with slag, and carried to the jaws of a squeezer by means of which the slag is squeezed out of them. The squeezed balls are sent to the rolls and are rolled into bars. The puddled bar, called the 'muck-bar' is cut into lengths, and the pieces are made into bundles, half the bars being piled cross-wise. They are wired together and heated in a re-heating furnace to a welding heat, then rolled into bars of a smaller size than the first. The re-rolled material is known as 'merchant bar,' and the effect of the further treatment is to eject more slag and cause a cross-fibre structure in result of the position of the cross-piled bars. A sample of hand-puddled bar has been found to contain carbon 0.296%, silicon 0.12%, sulphur 0.134%, and phosphorus 0.139 per cent.

165. STEEL-MAKING BY THE ACID BESSEMER PROCESS.

The pig-iron used in the bessemer process preferably contains 1% silicon and 0.5% manganese, but to make a salable steel, the phosphorus should be below 0.10% and the sulphur below 0.08%, since neither element is removed in the converter. If the silicon is above 1% the large quantity of slag produced carries away iron. If far below 1%, the charge does not blow hot. When manganese is high (1.5%), it makes the charge sloppy, the slag then being highly fluid and easily ejected during the blow.

The converters in a large plant are supplied from several blast-furnaces, and to insure a good average pig-metal, it is customary to collect the product of the several furnaces in a single tilting reverberatory furnace, called after the inventor the Jones mixer, capable of holding 300 tons of pig-metal. From the mixer it is drawn to the converters as needed, and a regular supply is thus insured.

166. THE ACID BESSEMER PROCESS.

The conversion is done in an upright converter, lined as shown in Fig. 184, with a lining of silicious material held together with

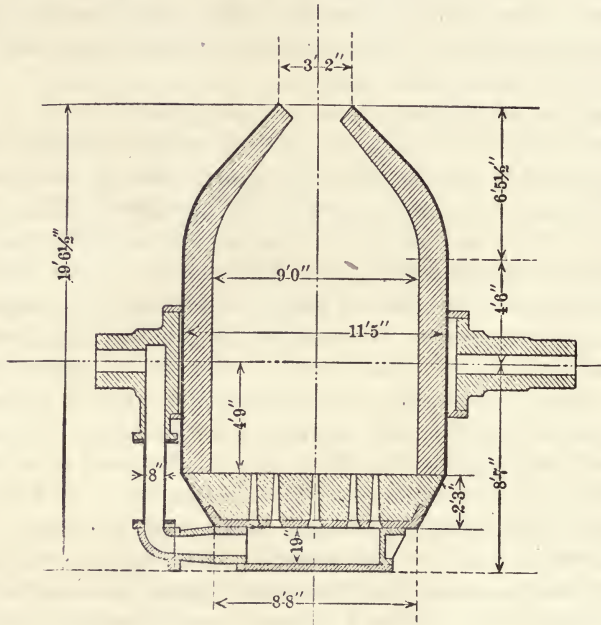

Fig. 184. SECTION OF BESSEMER CONVERTER IN UPRIGHT POSITION.

fire-clay. Fig. 184 represents a converter in vertical section. It is 9 ft. diam. by 15 ft. 6 in. high, and is capable of treating a charge of 15 tons of pig-metal. It is swung on trunnions, through one of which the compressed air needed in operation enters to the tuyeres at the bottom. The tuyeres are 19 in number and each is provided with 12 holes $\frac{3}{8}$ in. diam., or 228 holes in all. The slag made in a converter is high in silica, and has but little effect on the lining, so that the lining lasts several months. The mouth of the tuyere, however, comes in contact with the iron oxide formed during the

blow, and hence this part of the converter lasts only 20 to 25 hours. This bottom accordingly is made so that it can be replaced by another causing a delay of 20 minutes in changing.

Operation of the converter.—The hot converter, from which the metal of a blow has just been poured, is placed in a horizontal position and 15 tons pig-iron is poured into it by means of a ladle that is brought from the mixer. When the converter is in this position no metal can flow into the tuyeres and obstruct them. After the metal is poured in, the blast (or 'wind') is applied at the rate of 25,000 cu. ft. per min., the converter being at this time turned to the vertical position. The blast now blows in fine streams upward through 18 in. of molten metal. Active oxidation of the manganese and silicon results and in about four minutes they are oxidized by the oxygen of the air and have become slag. The carbon now begins to oxidize to CO, and this also streams upward through the metal and issues with the air from the mouth of the converter in a body of flame. After another six minutes the flame shortens or drops, and the operator, knowing that the carbon has been eliminated, turns the converter into horizontal position, the wind being at the same time shut off. In anticipation of this, a weighed quantity of spiegel iron or 'spiegel' has been tapped from the spiegel-cupola, where it is kept melted, into a ladle. The ladle is transferred by the traveling crane and poured into the converter. So great has been the heat evolved by the oxidization of the impurities of the pig during the ten minutes of the blow that the temperature is higher than at the start, and we have a white-hot liquid consisting of comparatively pure metal. Oxidation-products remain in the bath, and the carbon and manganese of the charge tend to reduce these, the unused carbon being in sufficient quantity to impart the desired strength to the steel. Silicon, which also is introduced, tends to dispose of gas contained in the metal. After the spiegel or 'recarburizer' has been added and the reactions have ended, the steel is poured from the converter into a ladle. The ladle, after a short interval, is carried to a position over the ingot molds into which the steel is to be teemed or poured. The teeming ladle is 'bottom-poured', that is, a tap-hole and plug are arranged in the bottom, so that when the ladle is brought over the ingot mold a stream of metal drops straight downward into it until it is filled; and so on, the molds are filled successively until the ladle has been emptied. The metal remains until solid, after which the molds are stripped, leaving the ingots standing. The ingot is picked up, and conveyed to a re-heating furnace, and finally sent to the rolls to

be formed into the shapes desired for market use. Fig. 185 illustrates graphically by curves the progress of the reactions, and the elimination of impurities during the blow. From it we see the rate at which the easily oxidized manganese and silicon are burned and also the carbon, which is but little acted upon until these disappear, but which after they are gone oxidizes rapidly. The pig contains at the beginning 3.5% C, 1.0% Si, and 0.5% Mn, all being removed. The recarburizer adds to it, as Fig. 185 indicates 1% Mn, 0.7% C, and 0.15% Si. The manganese is added to take from the metal the oxygen absorbed during the blow; the carbon is to give the steel

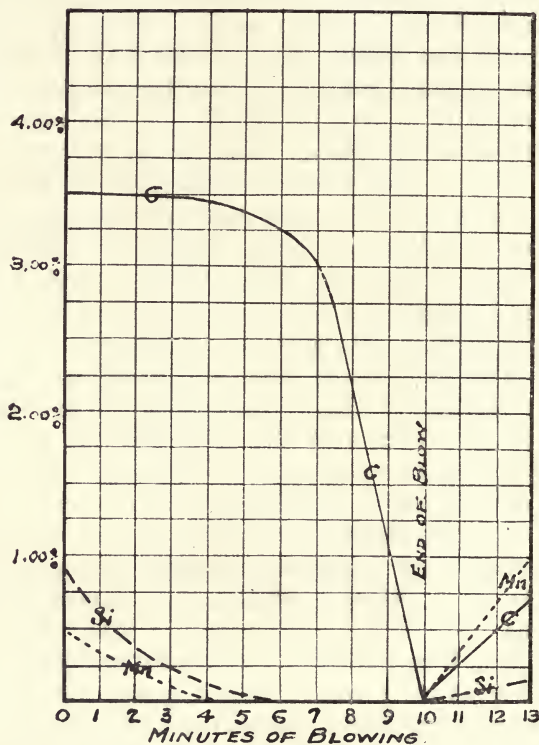

Fig. 185. ACID BESSEMER BLOW, AMERICAN PRACTICE.

the required strength and hardness, and the silicon to dispose of the gas contained in the bath.

167. THE BASIC OPEN-HEARTH PROCESS.

During the past fifteen years the bessemer process has been gradually giving way to the basic open-hearth process, due to the

fact that low phosphorus ore is being exhausted. Phosphorus imparts the quality of brittleness to steel if present in excess of 0.1%, and, since no phosphorus is eliminated in the bessemer process or in smelting, the iron ore supplied must be low in phosphorus. Suitable ore is called 'bessemer ore,' and ore having phosphorus above the desired limit is called non-bessemer ore. The limit may be considered 0.085 lb. phosphorus per 1000 lb. of iron in the ore. It is claimed that for most purposes open-hearth steel is better than bessemer, but the latter gives the most satisfactory product for tin-plates, and is well suited to the manufacture of rails. An important advantage in the basic open-hearth process is that it can be used for making steel from pig-iron and ore high in phosphorus. To make steel in this way, lime is added to produce a basic slag,

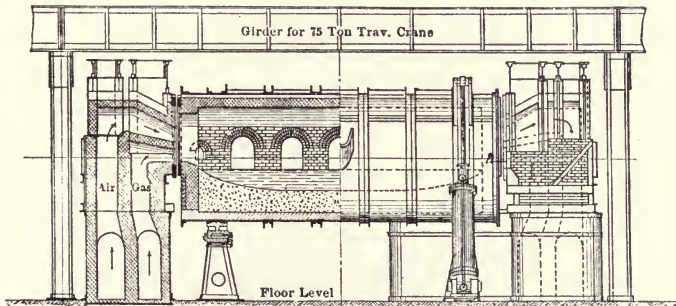

Fig. 186. LONGITUDINAL SECTION AND ELEVATION OF OPEN-HEARTH FURNACE.

the hearth is lined with basic material to withstand the action of the slag, and impure iron and scrap that contain phosphorus are used. To a limited extent, sulphur is removed by the operation.

Fig. 186 is a sectional elevation, and Fig. 187 a plan of a basic open-hearth furnace, having a hearth of 30 ft. 6 in. by 14 ft. wide. With the furnace two pairs of regenerating chambers are connected, one pair taking the heat from the product of combustion or waste gas after it leaves the furnace, and the other pair pre-heating the producer-gas and air entering the furnace. Every twenty minutes the current is reversed, the escaping gas going to the other pair of regenerators, while the air and gas go through the regenerators that have just been heated by the escaping product of combustion. In this way, not only is heat utilized for pre-heating, but the gas and air, thus pre-heated, naturally give a high temperature in the furnace. The heat in fact is so increased by successive reversals,

that it could be made to melt the roof of the furnace itself, and indeed care must be taken that it does not do this. As shown in the plan, a set of valves is provided. Certain valves are shown to be open, and others are closed, to adjust the currents as desired. Air and gas enter at the chambers at the left and the waste gas escapes

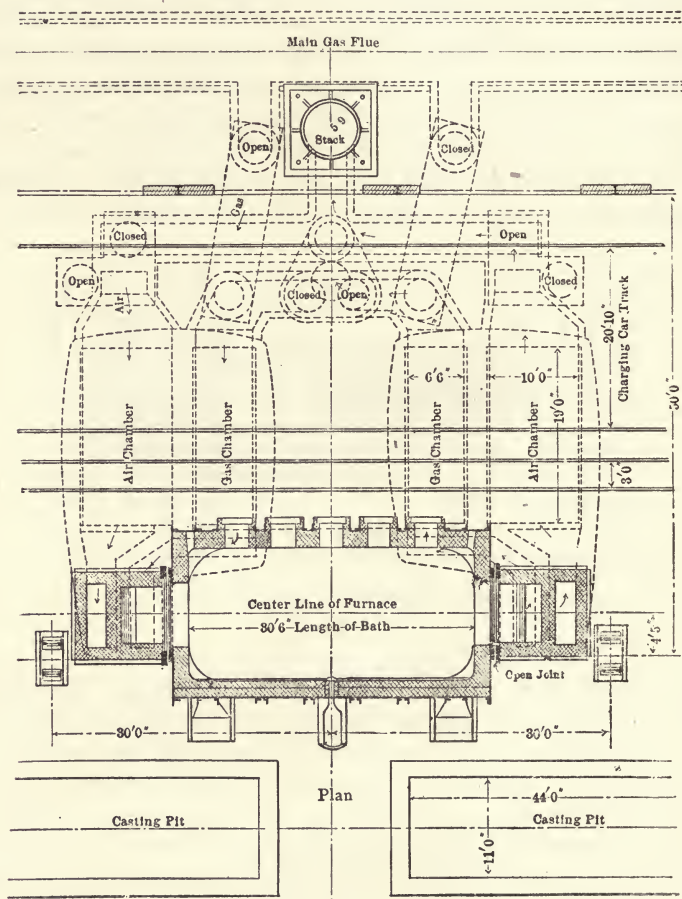

Fig. 187. SECTIONAL PLAN OF OPEN-HEARTH FURNACE.

through the other pair to the stack. The temperature of the checker work near the furnace becomes 1000°C ., and near the stack, 400°C .. Thus the air and gas entering the furnace become heated to 1000°C .. The highest temperature of the furnace is 1600 to 1700°C ..

The hearth of the furnace is lined to the depth of 24 in., and

carries a bath of molten metal of that depth, its surface being even with the level of the side door. The lining is of calcined dolomite (CaOMgO) held together with 10% its weight of anhydrous tar. The tar burns to a strong coke, that firmly unites the mass into a hard substance. Pure magnesite (MgO) is more expensive than dolomite, but it lasts longer and sometimes is used. It is the basic lining that gives the basic open-hearth furnace the name. The roof and side, above the slag level, are made of silica brick on account of the infusible nature of the material, and it is customary to put in a layer of neutral material, chromite brick (FeOCr_2O_3),

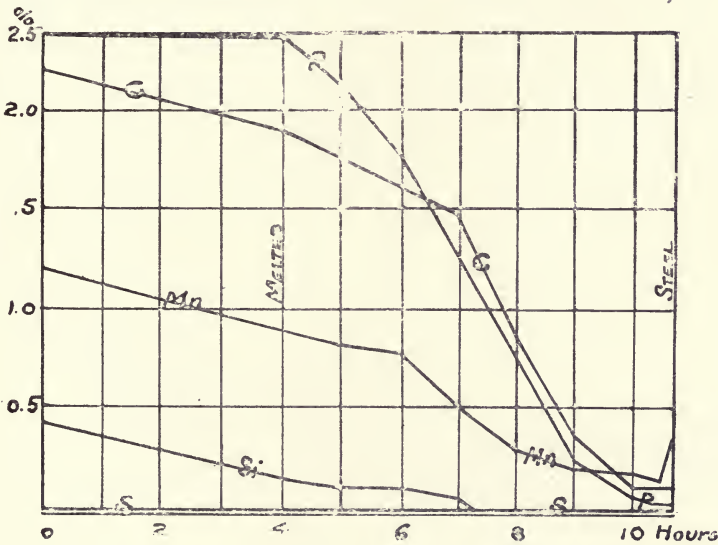

Fig. 188. CHEMICAL CHANGES IN BASIC OPEN-HEARTH PRESSES.

between the acid brick above and the basic lining below. A basic furnace lasts 350 hours (18 to 24 weeks) without radical repairs.

Operation.—In present practice the charge for a basic furnace consists of steel scrap (steel trimmed in the process of manufacture, old steel rails, and steel collected by junk dealers); of pig-iron containing less than 1% Si, more than 1% Mn, and up to 2% in P; of calcined limestone (quicklime) 8 to 30% of the charge; and of iron ore.

As shown in Fig. 188, it takes 4 hours to melt a charge, and 6 additional hours to complete the manipulation, so that in 10 hours the charge is ready to draw. During the 3 to 4-hour melting period, the carbon, manganese, and silicon we can see are reduced. The

reactions are controlled by the melter, who sees that the carbon is eliminated last, and if it is oxidizing too fast he must 'pig up' the charge by the addition of pig-iron to increase the carbon. On the other hand, if phosphorus is oxidizing too fast, the oxidation of the carbon can be hastened by 'oreing down' (adding iron ore) to produce the following reaction:

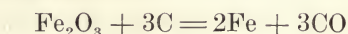

If carbon is eliminated too soon, much iron becomes oxidized. With the oxidation of silicon and phosphorus to silica and phosphoric acid, acids form with lime and iron oxide a basic slag containing 10 to 20% SiO_2 , 5 to 15% P, 45 to 55% CaO, and 10 to 25% Fe. The slag does not attack the basic-lined hearth, and retains the phosphorus and the sulphur, but the CaO must be as high as possible for this, and yet not so high as to render the slag infusible. After melting, active oxidation begins, and the bath boils by the escape of gas. Upon the completion of the operation the charge is ready for tapping into a 50-ton ladle, the metal filling the ladle and the light slag overflowing and being thus removed. If the slag remained, phosphorus would be reduced from it, upon addition of the recarburizer, and would again enter the steel.

The recarburizer is now added to the metal in the ladle. It consists of charcoal or coke contained in a dozen paper bags, each holding half a bushel. These are tossed into the ladle, then ferro-manganese is added, and then a pound of aluminum. Half the fuel is burned, half is absorbed by the steel; and the ferro-manganese supplies the necessary manganese and silicon and a part of the carbon. The aluminum absorbs oxidation products from the metal.

The ladle is now picked up by the 75-ton traveling crane, brought to the ingot molds, and turned into them. The further treatment of the steel has been described under the 'Bessemer Process.'

The furnace is patched or repaired where needed with a mixture of dolomite or magnesite and tar, and is ready for a new charge. As shown in the diagram Fig. 188, the resultant steel contains 0.35% manganese, 0.12% carbon, and still retains 0.050% phosphorus and 0.020% sulphur.

168. THE BETTS PROCESS FOR THE ELECTROLYTIC REFINING OF LEAD.

The principle of this process depends upon the solubility of lead in an acid solution of lead fluosilicate, which is used as an electrolyte. The solution is formed by diluting hydrofluoric acid con-

taining 35% HF with an equal volume of water and saturating with powdered quartz according to the reaction:

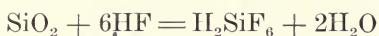

In the hydrofluosilicic ^{acid} lead is dissolved until the solution ^{contains} ~~is~~ 8% lead, after which there remains 11% H_2SiF_6 in excess.

The anodes are plates of the base-bullion to be refined, cast 2 in. thick, resembling ordinary copper anodes.

The cathode-sheets that receive the deposited lead are 'stripping plates,' obtained as in the case with copper cathodes. They are made by depositing lead upon steel cathode-plates, prepared for use by cleaning, coating with copper, lightly lead-plating them in the tanks, and greasing with paraffin. On them is deposited the lead, and when the coating is of the desired thickness the steel cathodes are removed from the bath, and the lead coating or sheets are stripped off for use as cathode. Another method consists in casting the cathodes in the form of thin sheets.

The anodes and cathodes are placed $1\frac{1}{2}$ to 2 in. apart in the tank. As in copper refining, the anodes are in multiple, and the tanks in series.

The fall of potential between anode and cathode is but 0.2 volt, and the current strength is 15 amp. per sq. ft. One ampere deposits $3\frac{1}{4}$ oz. lead per 24 hours following the ratio of the atomic weights of copper and lead which is 63 to 207.

In the process the impurities remain as an adherent coating on the anode, and consist of the copper, bismuth, arsenic, gold, and silver. The zinc, iron, cobalt, and nickel dissolve in the electrolyte.

As compared with ordinary refined lead, electrolytically-refined lead is pure, being practically free from bismuth, even when much is present in the base-bullion, and it is remembered that bismuth is harmful to 'corroding lead.'

The residue or anode-slime, averaging 8000 oz. or more of silver and gold per ton, is treated by boiling it with sulphuric acid, using a steam pipe inserted in the solution to boil and agitate it with free access of air. The washed residue is melted in a small basic-lined reverberatory-furnace, the copper is removed by using nitre as a flux, and the antimony by the addition of soda. The doré bars finally obtained are parted in the usual way with sulphuric acid.

PART X. PLANT AND EQUIPMENT

PART. X. PLANT AND EQUIPMENT.

169. PRIMARY PLANT AND EQUIPMENT.

A mine has a practical value only when it has been developed sufficiently to show what the future has to offer in erecting a reduction works. Where the value of the ore justifies, the beginning of metallurgical operations is kept simple, relying upon the skill of the workman, and not using a complicated plant. After knowledge is obtained in this way, the introduction of an efficient plant may be undertaken. This can be carried out to the best advantage, at times, by the erection of a single unit, adding other units when the first has been brought to a practical success.

170. LOCATION OF WORKS.

The location of a reduction works depends upon whether the ore of a single mine is to be treated or a custom-works is to be built. If a mining company builds a works to treat the ore of its own mine it is usual, in order to save the expense of transportation, to place the plant as near the mine as the securing of a suitable site and water-supply permits. In the case of a smelting works, where fuel and flux must be freighted, and where the product is to be shipped, then in addition to the above requirements, a site must be considered with reference to a railroad.

A custom-works, which buys ores from different mines and localities wherever it can, requires a place as convenient as possible to the chief source of supply and to the coke, flux, etc., that it must use. For such a plant, a point should be chosen where several railroads give rise to competition in freight rates. Such a center supports a large population, and this affords an abundant supply of labor.

The location of a works is also affected by the cost of freight on the ore and on the supplies such as fuel. It is also affected by the railroad and labor conditions, the local market, and the capital or credit for obtaining money at a low rate for operating.

Thus iron and steel manufacture has centered about Pittsburg, Pennsylvania, because coke, coal, and natural gas is abundant, and because a good market is found there for the products. On the other hand the iron smelter at Pittsburg must pay for freight from mine

to furnace, \$2.25 per ton, and must carry a large supply of ore to last through the winter months when navigation is closed. The United States Steel Corporation, the largest manufacturer of iron and steel in the world, is to erect a plant near the iron ranges at Duluth, Minnesota, for reasons shown below.

Vessels carrying iron ore to Lake Erie ports can return with cargoes of coke or coal to supply the Duluth furnaces. They then have a local market, and it is not necessary to 'stock up' with a winters supply of fuel. Figuring roughly that $2\frac{1}{2}$ tons coal, made into coke and into producer gas, is required to make a ton of steel, there is a slight advantage, as to fuel, in making coke in by-product ovens at Duluth, Minnesota, and using gas engines which utilize the blast-furnace gases to the best advantage. Nearly two tons of iron ore must be sent to Eastern furnaces to produce this one ton of steel.

It is seen from the cost of producing zinc, that 3.5 tons of coal are needed per ton of ore. Thus it is cheaper to convey ore to fuel, than coal to the mine where ore is produced. Near Joplin, Missouri, there is ore and also fuel, we expect, therefore, to find the zinc smelting works working there to the best advantage. The region is made more favorable by the fact that natural gas is to be had there.

With respect to silver-lead works using lead as a collector of other metals, the favored places have been found to be railroad centers, such as Denver, Pueblo, and Salt Lake. From 12 to 15% coke is used in the charge in such smelting, so that nearness to coal-fields is not the all-important condition. On the other hand, ores are available there in proportion favorable to combining profitably with one another. The lead of one ore and the iron of another being combined serve the requirements of smelting.

In treating ore by milling and cyaniding, the amount of fuel and other supplies required is small, and hence the natural place for the work is near the mine that produces the ore, provided the extraction, or recovery of the precious metals, is high. When, however, the ore is refractory and the recovery is low, it pays to ship the ore to smelting works that guarantee a high extraction.

The site.—The advantage in a side-hill (or terraced) site as related to the level or flat site has been much discussed. It has been claimed as an advantage, that the former permits the ore to advance by gravity from one operation to the next, and that, as it becomes reduced, there is no necessity to again elevate it.

On the other hand the flat site has the following advantages:

(1) The first cost of the works is small, since grading and retaining walls, that would be needed on a side-hill site, are reduced to a minimum.

(2) The arrangement can be more convenient, since there is no need, as in a side-hill plant, to place the different parts of the plant in definite order to obtain the required fall. When it is desired to expand the works, it is possible to extend in any direction.

(3) Every square foot of ground can be made the equivalent to a lower or an upper terrace or can be left level. Hence the parts of the plant that must be far apart, on a terrace site, can be side by side on a level one. Ventilation is good and the plant is accessible for supervision.

Of course on a level site one must use elevators or other hoisting appliances, but it is seldom that we find a terrace site where elevators are not used. Certain products often must be returned for re-treatment, and the cost of elevating is less than 0.5c. per ton.

Iron and steel plants, the largest in the world, are constructed on level ground. The ore is unloaded direct from vessels to the stock pile, using grab-buckets holding 5 to 10 tons each. If transported in cars, the cars are loaded in a similar manner. The custom is to use hopper-bottom cars, from which the ore drops into the charging bins, and thence by charge-cars is conveyed to the furnace-skip. By the skip it is hoisted 100 ft. to the furnace-top. Many recent silver-lead smelting plants occupy level sites, but the dumping-ground is at a lower level.

For iron works little attention is paid to the location of the dump. There is no hesitation in sending the slag, if necessary, a mile away by locomotive to be dumped.

Mill-sites.—On the unclaimed mineral lands of the Western United States, title is secured from the general government for a mill-site for reduction works, five acres in extent, either in connection with a mining claim (on a theory that each mining lode is entitled to a mill-site) or as a site for an independent or custom reduction plant. A reduction company, operating a mill, must dispose of the tailing it produces, and of the water discharged, not encroaching upon the property of other people, and it is responsible for all damages. A company must not let tailing flow into a stream that, at a reasonable cost, can be impounded, nor run into waters where liable to interfere with navigation. The right or custom of dumping on the valueless land of lower mining claims is general, except that the practice must do no damage to the property of owners below.

A reclamation company can take up lands for a ditch or flume from unappropriated public land, and the claim can not be interfered with by later locators; but the owner of such a ditch or flume is responsible for damage arising from breaks or overflows.

The same rule holds with respect to roads and trails. In Colorado, mining claims are subject to the right-of-way to parties hauling ore over them, but in other States the location gives exclusive control, except that a water, electric, or railroad company can take it under the law of eminent domain by giving a fair compensation for it.

The smoke from the smelting works, especially those treating sulphide ore in quantity, delivers into the atmosphere many tons of sulphur-fume daily, as well as fine flue-dust carried out of the stack by the draft. This diffuses through the atmosphere and is carried by the wind to trees and the crops of the land. If not diluted, it blights vegetation, and naturally the farmers organize to secure damage, or to close the works. The question of what to do to avoid the difficulties is a serious one, and today when pyrite smelting and extensive roasting of sulphide ores is in practice, the trouble can not be altogether overcome. Thus far the solution has consisted in locating the works in places where there is little vegetation to be damaged, or in discharging the fume into the atmosphere from high stacks. It may be said that the latter expedient lessens but does not altogether obviate the difficulties. The metallurgist must give serious consideration to the matter therefore, otherwise, after erecting and starting the operation of a plant, he may find that he is compelled to close it, to the ruin of the entire enterprise.

171. INSTALLATION OF PLANT AND EQUIPMENT.

Preliminary to building a plant and operating a works, an investigation is made of the process, the requirements of the plant, and all limiting conditions. It includes, besides the general matters outlined above, the questions of supplies, markets, railroad facilities, freight rates, sufficient and suitable labor not liable to strikes, and reliable civil conditions unaffected by revolutions or oppression by the government under which the plant must operate.

Next comes the organization of the operating company and financing of the enterprise, or obtaining capital to build and operate the plant until it pays the operating costs.

Often the promoters, besides owning the mine for which the reclamation works are built, have acquired the necessary real estate and

the rights that go with it. Provisions should be made for access by railroads, for the necessary trackage, and for the common roads to the plant. Not only must water and power be provided, but right-of-way for securing them. If fluxes are needed then the proper quarries or deposits must be found.

Construction.—Before beginning construction, plans should be fully worked out by competent engineers. Cost estimates are made in detail, good materials are accumulated, and the labor-force is properly organized. In the design of the plant provision for duplicate parts is made, so that in case of break-down no interruption of operation occurs.

On beginning construction the hydraulic works, where needed, are put in under skilled supervision. This includes the building of dams, reservoirs, the water-power plant, and transmission line. For a long-distance power-transmission line there may have to be sub-stations and a distributing system.

Money must be provided for the salaries of officers of the company that are to receive pay during the period of construction, and all money expended must be accounted for, and cost-records kept by a skilled accountant. The money needed for legal expenses, general expense, traveling expense, and all expenses incurred during construction must be included.

Equipment.—This includes the machinery, furnace-tools, and appliances used in operating, but excludes land, buildings, and trackage. Labor-saving machinery, when reliable, effects a saving in costs, but it is remembered that this saving must not sacrifice the efficiency of operation. The question 'how much' often arises, and we may even come to the conclusion that it is not desirable (considering the cost of installation) to put in the labor saving appliance.

172. HANDLING MATERIALS.

The application of machinery to the handling of materials has of late years received much attention. It has been rapidly developed because of the resulting economy in labor.

For handling on one level, 100 tons or less of material daily, especially where the ore is to be distributed to various places, one or two-wheeled buggies, or barrows, on a good floor, have been found to be economical, elastic, and low in first cost. For small quantities the metallurgist is not led into installing machinery, for he finds in practice that it effects no saving. For large quantities barrows or buggies may be used, or hand-propelled tram-cars, as in mining. For still larger quantities, power-propelled cars are

used, that can be handled also on up-grades and sent from level to level. The idea is well carried out at the Washoe plant of the Anaconda Copper Mining Co., where industrial locomotives move thousands of tons of material daily from level to level. Indeed the

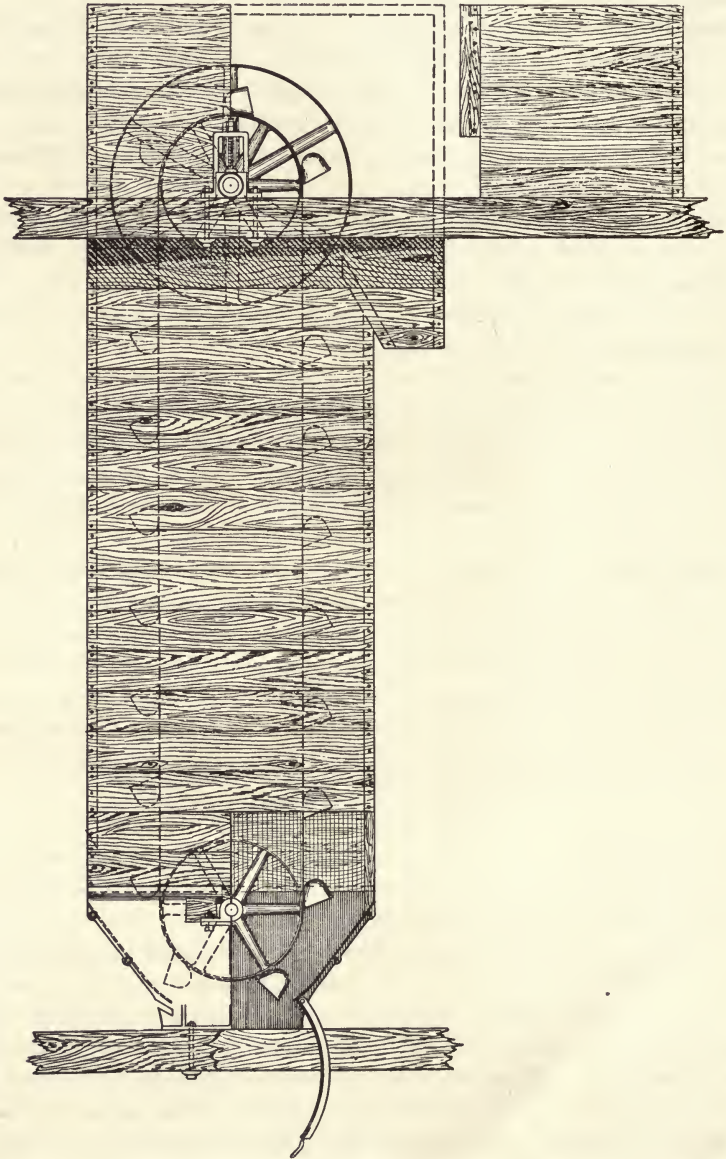

Fig. 189. VERTICAL BELT ELEVATOR.

plant is an admirable example of how a side-hill site becomes effective, where locomotives can be used.

Appliances for mechanical handling are divided into continuous machines, and appliances for intermittent handling, such as light railways and cranes.

Continuous machines.—These carry a distributed load, so that the sub-structure upon which they rest is light compared with one upon which the load is concentrated as in a car. They deliver material continuously, and no time is lost in loading and unloading. Intermittent conveying, on the contrary, if we increase the load of the skip or bucket, becomes slow and awkward, whereas in the continuous conveyor it is possible to increase the capacity by widening the conveyor and providing the correspondingly increased feed.

We divide continuous machines into elevators, conveyors, and conveyor-elevators.

Elevators are used for vertical or nearly vertical lifting. The belt elevator, Fig. 189, is of this type, and consists of an endless



Fig. 190. STEEL ELEVATOR BUCKET.

belt having sheet-steel buckets, Fig. 190, attached by flat-headed elevator-bolts at 18-in. intervals. To allow for the stretching of the belt, the upper pulley shaft is carried in take-up boxes, by which the shaft can be raised. It is generally preferable, however, to use the take-up boxes for the lower pulley-shaft. The lower pulley is enclosed in a boot, the ore delivering into the buckets at the rising side, shown at the left. Ore, not caught by the buckets, falls into the boot and is there scooped out by buckets. The boot has a hinged drop-bottom, so that it can be cleaned out when desired. The drop-bottom is of particular advantage for elevators used in a sampling mill in cleaning up between samples. The speed of the belt is 275 to 300 ft. per min. to insure that the material delivers to the discharge spout by centrifugal action, as the buckets pass over the top pulley. At this speed a belt-elevator, having buckets 8 in. wide, delivers 7 tons per hour, and a 10-in. bucket-elevator, 18 tons per hour. The head and boot-pulleys are 30 in. diam. and,

as well as the belt, are made 1 to 2 in. wider than the buckets. The whole is inclosed in a wooden housing to prevent the escape of dust.

Fig. 191 represents a single-strand endless-chain elevator. The chain is carried by head and foot sprocket-wheels with sprockets spaced to take links of the chain. In this case the 'take-ups' are



Fig. 191. SINGLE-STRAND ENDLESS-CHAIN ELEVATOR.

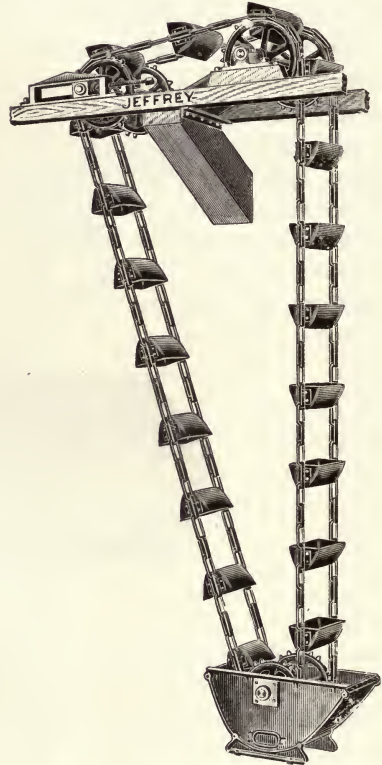

Fig. 191. SINGLE-STRAND ENDLESS-CHAIN ELEVATOR.

carried by the boot. As is the case with the belt-elevator, the velocity should be sufficient to insure an efficient discharge from the buckets; but chain elevators, because of the numerous joints, are not well suited to run at a high velocity.

Fig. 192 is a double-strand endless-chain elevator having two head-pulleys arranged so that the buckets discharge into a spout between them. In this way the elevator can be run at the low velocity suited to the type. To take up the slack, the shaft of the second head-pulley is carried by horizontally moving take-up boxes.

Either of the endless-chain elevators can be housed, in wood as in Fig. 189, or in a sheet-iron.

Conveyors are used for the horizontal transfer of materials, and can be modified easily to carry up an incline. Of all conveyors, the belt-conveyor is most widely used. To give it capacity it is troughed by running on pulleys that raise the edges of the belt forming a shallow trough (See Fig. 193). The simplest form is an endless belt running over end-pulleys, the load being fed at one end, delivering into a chute or into a bin at the other. The conveyor carries a load not only on a level, but on as steep as 24° incline.

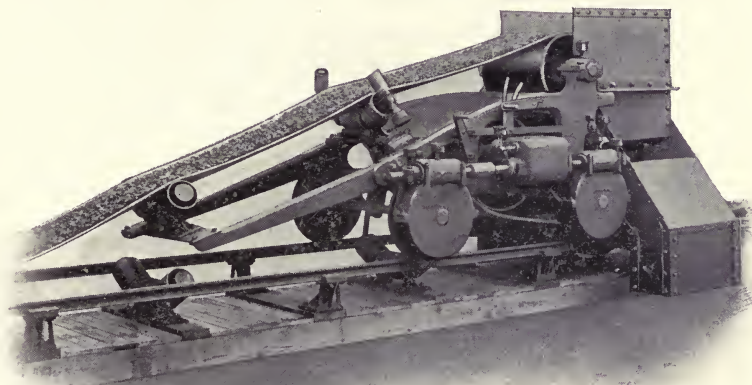

Fig. 193. CONVEYING BELT WITH TRIPPER.

The capacity is large and the conveyors are simple and durable. A 12-in. belt, traveling at the rate of 150 to 350 ft. per min., delivers 10 to 35 tons per hour. A 24-in. belt, traveling at the extreme velocity of 600 ft. per min., has a capacity of 250 tons per hour of crushed ore, and requires 6 hp. per 100-ft. length, the power needed varying with the length of the belt. When the ore ascends an incline we add the power for lifting the load. It is desired at times to deliver the ore into bins situated at different points along the belt. This is accomplished by using the movable tripper shown in Fig 193, which also shows the belt loaded with ore. To discharge the ore the belt goes around the upper pulley, as shown, then around a second one just below, and continues the course to the front end-pulley. The ore shoots from the belt into spouts, that deliver on either side of the track upon which the tripper moves. Indeed the tripper is sometimes made to travel continuously back and forth

from end to end of a long bin at the rate of 200 ft. per minute, evenly distributing the ore and bedding it. The bin when full supplies the furnace, and the ore is of an even constitution throughout.

The worm or screw-conveyor.—This is convenient for delivering crushed ore short distances, and it thoroughly mixes the ore conveyed. Fig. 194 represents a screw-conveyor delivering ore from the trough along which it has been conveyed, into another at right angles. The ore drops from the first to the second, and is conveyed by the screw in the second, shown at the left. The bottom of the trough is lined with smooth sheet-steel bent half round to conform to the worm or screw. A screw conveyor is shown in Fig. 111 illustrating a dry-crushing silver-mill. The disadvantages of this

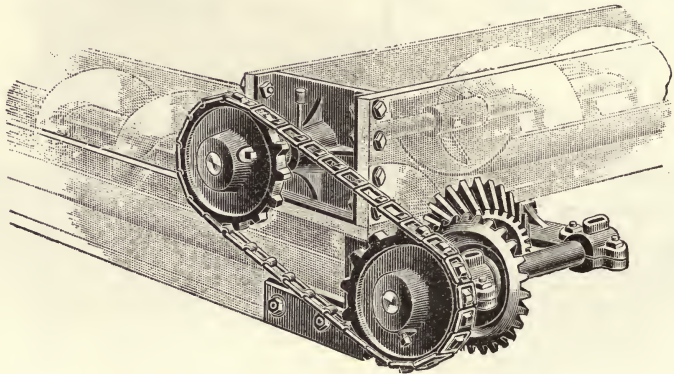

Fig. 194. SCREW CONVEYER (QUARTER TURN).

type of conveyor are, that much power is needed, and that the ore grinds on the conveyor resulting in wear. It is well adapted to carrying a moderate and continuous supply of ore short distances.

Endless-chain conveyors.—These are much used, since they convey ore not only on a level, but vertically if necessary. Being entirely of metal they successfully convey hot materials.

Fig. 195 represents an endless-chain push-conveyor, consisting of a series of plates or 'flights' attached to a double endless-chain carried at each end by sprocket-wheels like the double endless-chain elevator Fig. 192. The ore, drawn from any desired storage-bin as shown in the figure, is pushed up an incline by the moving flights in a fixed steel-lined trough, and is taken by a double-strand endless-chain elevator to a floor above. If desired, slides may be provided in the bottom of the trough. When the slide is opened, the ore drops into the desired bin beneath.

Sometimes in place of flights, a continuous series of buckets

or trays is used. These overlap so that the ore can not drop between them. They operate upon the principle of the Howden pig-casting machine, Fig. 126. Indeed the conveyors lend themselves to a great variety of applications, as the examination of a catalogue of elevating and conveying apparatus will show. The chief draw-back to them is that they have numerous joints to wear, and that the troughs, flights, or buckets are subjected to serious wear. They must run slower than the belt-conveyor.

In Fig. 38 and 39, the Edwards roasting-furnace, we have an example of a swinging push-conveyor. The flights are bladed and so hinged from the vibrating carrying-beam as to swing over the ore

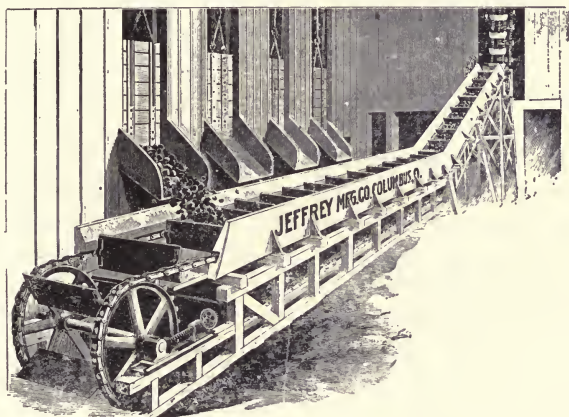

Fig. 195. ENDLESS-CHAIN PUSH CONVEYOR.

in the conveying trough on the backward motion, but to push the ore along when moving forward. As is seen, the bottom of the trough is provided with slides to deliver the ore where it is needed.

Vibrating-trough conveyors.—These are of a simple type, consisting of a sheet-steel flat-bottomed trough, 50 ft. long by 2 ft. wide, supported by spring legs, and receiving a throw of 1 in. from an eccentric making 300 rev. per min. The conveyors can be arranged to deliver into one another, in series, a distance of 500 ft. if desired. Owing to the inclination of the spring legs, the trough rises in the forward motion and drops in the backward motion, so that the material is propelled to the discharge end. The conveyors are simple, inexpensive, and need few repairs. A conveyor, having a trough 24 in. wide, has a capacity of 20 to 25 tons per hour. When provided with a double or false bottom, the upper one being a screen, the conveyor can be made an effective screening apparatus.

Hoists.—Of these, the commonest about reduction works is the platform elevator, which takes buggies, wheelbarrows, or tram-cars from floor to floor. It may have a platform of a size (6 by 6 ft.) to receive two cars or wheelbarrows at a time, and it raises a one-ton load 60 ft. per min. They are often run in balance, but it is better to have two independent counterweighted platforms. Necessarily, time is lost in loading and unloading, so that the estimate of the capacity is 25 tons hourly.

Fig. 122 shows an iron blast-furnace having a platform-hoist, and Fig. 121, one having a skip-hoist adapted to mechanical charging. The capacity of the skip is 2 to 5 tons of ore to half the quantity of coke, and they are run in balance. It takes 34 seconds actual time for raising, dumping, and returning the skip to pit; but the total time including the waits is 4 minutes, this furnishing the supply to a furnace producing 350 to 500 tons of pig-iron daily from a total burden of 1150 to 1650 tons.

Industrial railways and tram-tracks.—We already have referred to the use of these in industrial work. Where an industrial locomotive can be used it is possible to convey on up-grades, taking advantage of side-hill grades, or of trestles. Trestles are used about level sites, and by means of them ore can be conveyed in hopper-bottom cars and dumped into storage or charge-pockets. Fig. 137 shows an electric power system with a motor for handling a 31 cu. ft. or $3\frac{1}{2}$ -ton slag-car, as used at the United Verde Smelting works, Jerome, Arizona.

Grabs.—In large establishments hoisting rigs are used that are provided with large clam-shell buckets or grabs. They take 5 to 10 tons of ore at a time, and are used for unloading vessels, and for transferring ore to stock-piles for storage, or to the furnace storage bins as desired. It is noticed that the movable frames or bridges are made heavy to carry the large loads safely.

The traveling crane.—Fig. 143 gives in elevation a traveling crane as commonly used. It is for handling ladles and converters as described under copper-converting and for bessemer and open-hearth practice. For handling materials inside a building it is coming into general use. The cranes are operated by electricity, and move in any direction, horizontally or vertically, over the floor of the building commanded by them, and they avoid obstacles on the floor. Provided with large mushroom-shaped electro-magnets, they are now used to unload pig-iron or handle steel sheets weighing a ton or more, and by using them no time is lost as in older methods, in passing chains around objects to be lifted.

PART XI. COMMERCIAL

)

PART XI. COMMERCIAL.

173. KINDS OF WORKS.

There are two classes of metallurgical works; those constructed at mines, and custom-works.

A mine-works gets the ore-supply from the mine of the company. In such case, it does not pay for the ore it receives, and the operation-cost, being only that of reducing the ore, is low.

A custom-works, that includes the purchase of ores among the items of cost, has here a serious item of expense. This is especially applicable in the case of the treatment of precious-metal ores. The stock of ore that must be carried depends upon the distance from the mines, and upon the certainty of the supply. In the case of the Lake Superior iron-ore supply, for example, a stock must be accumulated by the beginning of the winter to supply the furnaces until the opening of navigation in the spring, a period of six months. The silver-lead and copper smelting-works of the Rocky Mountain States carry a supply to last two to six weeks. We have already alluded, under 'Electrolytic Refining,' to the capital locked up by the process. On the other hand, at a mine-works, the supply can be replenished as used, so that provision is needed only for one to two days' running, and often for but half-a-day's run.

174. ORGANIZATION OF A METALLURGICAL COMPANY.

Metallurgical operations on a commercial scale require, generally, the organization of a company, or if the company is already organized, the establishment of a department to provide the additional function.

Where a metallurgical company is to be organized, the promoters or organizers obtain a charter, or articles of incorporation, from the State in which they desire to incorporate. They next hold a meeting at which they receive the property that is to be taken over by the company, adopt a set of by-laws for the guidance of the company, and elect the directors that are to manage the affairs.

The directors proceed to the election of the corporate officers of the company from their number. The officers, of a small

company, are the president, the vice-president, the secretary, and the treasurer. The directors may appoint from their number a managing director, or they appoint a manager from the outside to have charge of the affairs of the company.

In outlining the organization of a company undertaking metallurgical works, the manager should be guided by the following rules:

(1) He should see that a supreme authority is provided over all action to be taken, and should carefully and fully outline the authority and responsibility of each position, making the duties of each conform to the capability of the party holding it. To do this he must avoid making any person subordinate to two or more; should place the authority and responsibility together; should distribute the work and the duties not to overburden nor to underload; and should arrange the positions so that promotion can come from them. While the manager gives his chief attention to the commercial or business affairs of the company, he generally appoints a superintendent to attend to the technical affairs of the plant.

The organization, under the charge of the manager, may include (1) the supply, (2) the operating, (3) the accounting, and (4) the selling department.

(1) The supply department attends to the purchase, and delivery of ore, fuel, and flux, and to the care and issuing of chemical and general supplies.

(2) The operating department has to do with all that pertains to the reduction or manufacture of the ore into metal (the winning of the metal from ore) or to refining metals to bring them into marketable form, and has control of the operating forces, consisting of the foremen (and men under them), the repair force (consisting of mechanics and their helpers who keep the plant in repair and put in the needed improvements), and the laboratory or assay-office force.

(3) The accounting department attends to the accounting, payroll, cost-keeping, and the distribution of costs.

(4) The selling department attends to the disposal and sale of the product of the works. By-products, in process of further treatment, are not here included.

175. THE PURCHASE OF ORES.

Smelting works purchase ores of every kind according to the requirements, provided the ores are sufficiently valuable to pay for

treatment. They are purchased according to the content and by a pre-arranged schedule.

176. IRON ORES.

These are purchased by guarantee on the part of the shipper that they will come up to a given standard that generally is based upon the percentage-content in natural condition, thus including the contained moisture. For Lake Superior ore the prices for 1908 at Lake Erie ports, per long ton (2240 lb.) were:

Old Range bessemer, 55% iron base.....	\$4.50
Old Range non-bessemer, 51.5% iron base....	3.70
Mesabi bessemer, 55% iron base.....	4.25
Mesabi non-bessemer, 51.5% iron base.....	3.50

The Old Range ores come from the iron ranges on the south side of Lake Superior, and command a higher price because of the better mechanical condition. The Mesabi ores are soft, friable, and carry much fine, which makes flue-dust. When smelting such ore, in ratio of 85% soft to 15% hard ore, as much as 6% flue-dust or dirt is made.

On a non-bessemer ore, as it varies from this, a premium of 8.349c. is paid for each per cent iron over the guarantee, and a penalty or deduction is made of 8.349c. down to 50% iron, of 12.523c. down to 49% iron, and a double penalty down to 48% iron. Below 48%, the penalty becomes 18c. per unit.

On bessemer ore, provision is made for a premium only in case the ore exceeds the guaranteed 55% iron.

177. ORES USED IN SILVER-LEAD SMELTING.

A schedule for the purchase of silver-lead ores in Clear Creek and Gilpin counties, Colorado, is here given, dated Feb. 1, 1905, f. o. b. cars at Denver, based on the dry-weight of the ore. The ton used is the short ton of 2000 pounds.

Dry tailing and concentrate.—Gold, \$19 per ounce, if 0.05 oz. or more per ton; silver, 95% of the New York quotation on the day of assay, if 1 oz. or more per ton.

Copper, dry-assay (wet less 1.5 units),

	Per Unit.
5% or less.....	\$1.25
Over 5% and including 10%.....	1.50
Over 10%.....	1.75

10% silica basis, 10c. up; 5% zinc basis 30c. up.

Gross value of ore.	Treatment per Ton.
Not over \$35 per ton.....	\$3.50
Over \$35 and including \$80 per ton.....	4.00
Over \$80 per ton.....	5.00
Upon lots containing less than 7 tons.....	5.00

Dry-silicious and copper-bearing ore.—Gold, silver, and copper are paid for as in the schedule for concentrate.

Treatment charge \$8 on a 40% silica basis, 5c. down and 10c. up to a maximum charge of \$11 on ores not exceeding \$25 gross value; 5% zinc limit 30c. up.

Lead ore.—Gold \$19.50 per oz., silver 95% of the New York quotation on the day of assay, copper \$1 per unit dry (wet less 1.5 units) when ore assays 2% or over wet; 10% zinc basis, 50c. up.

NEUTRAL SCHEDULE.

Lead Inclusive Per Cent.	Per Unit Cents.	Treatment Charge.
5 to 10	25	\$8.00
10 to 15	25	7.00
15 to 20	25	5.00
20 to 25	25	4.00
25 to 30	30	4.00
30 to 35	30	3.00
35 to 40	30	2.50
40 to 45	32	2.00
45 to 50	35	2.00
Over 50	40	2.00

NEUTRAL BASIS 10c UP or DOWN.
FLAT SCHEDULE.

Lead Inclusive Per Cent.	Per Unit Cents.	Treatment Charge.
5 to 10	25	\$12.00
10 to 15	25	10.50
15 to 20	25	8.50
20 to 25	25	6.50
25 to 30	30	6.00
30 to 35	30	4.50
35 to 40	30	3.00
40 to 45	32	2.00
45 to 50	35	2.00
Over 50	40	2.00

Neutral basis, 10c. up or down. The schedule most favorable for the shipper to be used.

Oxidized irony ores.—Gold and silver are valued as in the schedule for concentrate. Lead 25c. per unit for 5% or over. Treatment charge \$2 on a neutral basis, 10c. per unit up.

Lead concentrate.—Gold \$19 per oz. if 0.05 oz. or over per ton; silver and copper as in lead ores. Silica basis 10%, 10c. up; 5% zinc limit, 30c. up.

Lead Inclusive Per Cent.	Per Unit Cents.	Treatment Charge.
5 to 10	25	\$4.75
10 to 15	24	4.00
15 to 20	30	3.50
20 to 25	32	3.25
25 to 30	35	3.25

Upon concentrate assaying over 30% lead apply either the neutral schedule or the flat schedule as under 'Lead Ores,' whichever favors the shipper.

Copper ores were formerly purchased upon the result of the fire-assay, which experience shows to be about 1.5% low. It was considered that the fire-assay expressed what was to be obtained from the ore when treated on a full scale in the furnace. If analysis shows that the percentage of SiO_2 is equal to that of Fe, the iron present is considered able to flux the silica, and the ore is called self-fluxing and is said to be neutral, the base (iron) neutralizing the acid (silica). If more silica than iron is present then the difference in percentage is called the silica excess, and the reverse when iron is in excess. Zinc is detrimental to smelting, and if an ore has more than 5%, a charge is made against the ore or a penalty, as it is called, is exacted by the smelting company. Flat prices are paid for the lead, that is, they remain the same whether the price of lead rises or falls. Concentrate (the granular product made in dressing or concentrating ore) containing no lead but consisting of iron or copper sulphide, is called dry. The value is in the contained silver and gold. Lead concentrate is valued also for the contained lead.

As an example of the use of the above schedule, let us take an ore containing SiO_2 , 14%; Fe, 6%; Zn, 11%; Mn, 4%; S, 10%; Pb, 21%; with 60 oz. Ag and 0.2 oz. Au per ton. The ore is evidently a lead ore, and we will figure it on both the neutral and the flat schedule given under 'Lead Ore.'

We find a silica excess of 4% over the iron and manganese. The excess of zinc over 10% is one per cent.

On the neutral schedule we have:

Gold, 0.2 oz. at \$19.50.....	\$ 3.50
Silver, 60 oz. at 95% of 62c. (New York quotation).....	35.34
Lead 21% (21 units) at 25c.....	5.25

Total metal value.....	\$44.49
Deducting treatment, \$4 + (4% SiO ₂ excess at 10c.) + (1% Zn excess at 50c.)	4.90

Net returns to the shipper f. o. b. Denver.....\$39.59

On the flat schedule we have:

Total metal value as before.....	\$44.49
Deducting \$6.50 treatment + 50c. zinc penalty.....	7.00

Net returns to shipper f. o. b. Denver.....\$37.49

Therefore the neutral schedule is more favorable to the shipper and is the one used.

178. SCHEDULE FOR COPPER ORES.

Low-grade copper sulphide.—Ores figured f. o. b. Tacoma, Washington, 1907, per short ton dry-weight. Gold \$20 per ounce, silver 95% the New York quotation, day of assay, copper 3c. per pound less than New York quotation.

	Treatment Charge.
When net value is less than \$5 per ton.....	\$3.25
“ “ “ “ more than \$5 per ton.....	3.45

While the above schedules give an idea of prices on which to base estimates of the value of ores, most buying is done by special arrangement, and time-contracts are made for the delivery of ore. The skilled buyer, well informed in the details of the business, is apt to have an advantage over the shipper, and can make profitable contracts for his company. Often there is but one buyer, who has much his own way, but the seller, who can show to the buyer that he is well posted, makes better terms.

Other supplies.—With the exception of ores, fuel, and fluxes, supplies are kept in a store-room, and issued by the supply department only on a written order from the foreman or other responsible party that needs them. In this way is known where the supplies are to be distributed on the cost sheets. An account is kept of all

supplies received and issued, so that from it can be learned how much and when to order to keep properly stocked. It is detrimental to the business to so run out of supplies as to cause delays.

Much knowledge is required in the purchase of supplies, to buy when prices are low or on a rising market, but only in small quantity on a falling market, and to obtain the best discounts, but care is taken to avoid the purchase of inferior goods.

179. THE OPERATING DEPARTMENT.

The choice of men to operate a plant is often the important condition to the success of the enterprise.

The superintendent not only must be informed as to the actual technical operations, but he must know how to arrange and organize his forces. He should be able to handle men effectively, and must possess tact, discretion, and firmness. He must be strict and just, and able to encourage as well as to drive. He is often the metallurgist as well as the superintendent, and has direct management of the furnaces and the metallurgical machinery. When things go wrong it is he that is called upon to correct them, at whatever hour of the day or night. If a furnace is in bad condition or a machine out of order, he is responsible. If all is going smoothly his duty may be light, but when troubles occur, or when the company is losing money, his work is hard. If he fails in adjusting difficulties, no excuse is accepted. He must succeed or must resign. Much of his success depends upon his subordinates, and first in importance among them we must place the foremen.

In early times the success of the operation depended upon the skill of the workmen. Today, manual skill must be supplemented by intellectual skill to insure the certain and exact operation of the plant. At first, the puddler worked up his charge of iron by hard labor. Today he operates levers and watches the progress of the successive operations. In place of muscular effort the workman now must supply intelligent direction.

The payment for the work of supervision and control, as for the office force, superintendent, assayer, chemist, and foremen, is made monthly. In certain cases an additional premium is paid. In plants where the exhaustion of a mine or of a mining district may cause the closing of a works, premiums can hardly be assured. The premium method, however, has been found to give good results, especially where rated on tonnage, or in the case of the superintendent, on the lessening of costs. There is a decided difference between the incentive of a man who draws his salary in any case, and one who

knows that his compensation increases with his diligence and effort to practice economy.

Engineering is the art of doing with one dollar what ordinary man may, after a fashion, do with two; hence a competent man, who is a trained expert, is necessary to best results, and where the margin of profit is small, he is absolutely essential. When the price of the metal being produced is high, and the margin of profit is large, tonnage is more important than economy.

The capacity and efficiency of a plant depends on the intelligence and reliability of the men in charge of the different departments, and they are chosen with these qualities in view. The low-grade labor is used where hard routine work comes in, the high where judgment is essential. While low-grade labor may be faithful, it is stupid and liable to blunders; when trained, however, if faithful, it becomes reliable. The employment of cheap men for supervising costly machines is offset by the loss of time or by actual disaster.

Qualities of a foreman.—A foreman often is a man that has been advanced from a subordinate position in the works. He may be selected from among several applicants from the outside. In quizzing an applicant, note the names of his former employers, ask him if he 'gets on' well with his men, if he scolds them, if he has been threatened by them, or if he treats them with consideration. A foreman must not be thought to be a 'good fellow' (an 'easy fellow') by his men. He may, himself, sometimes lead off in the work and show his men how to do things, but in general he has enough to do in seeing that they are all busy.

The foreman not only must watch the progress of the work, but plan ahead, to be sure that everything is provided and ready at hand as needed. In such work the foreman need not be always so strict a disciplinarian. On routine work, and in order to drive, especially when he has many men to handle, he must be just, having reserve of manner, but looking to the welfare of the men while at work.

The chemist, or assayer.—The chemist or the assayer is called upon for results regarding the operation of the plant, and these he must furnish with promptness and accuracy. Besides, in his routine work, his skill and value is found in investigation under the director and advice of the metallurgist or superintendent.

The construction force.—The various mechanics (blacksmith, carpenter, engineer, and machinist) not only have repairs, but also new construction to attend to, under the personal direction of the superintendent, who may, where the work requires, employ a drafts-

man or constructing engineer to attend to construction. It is a rule, in case of a break-down or other emergency, when the general foreman in charge of operating needs aid, that this work has precedence, and other work must be dropped to expedite it.

Skilled and unskilled labor.—The ten-hour labor at the reduction works is largely unskilled or common labor. These laborers are called 'outside men' or 'roustabouts.' They do the work requiring the use of pick and shovel, such as unloading cars, handling the products of the works, and assisting in the construction or repairs.

Skilled laborers working in shifts of eight to twelve hours, called also 'inside labor' receive higher pay per hour than common laborers. The pay varies according to the skill needed. These men are responsible for the successful performance of the duties given them, and they are expected to work until they are relieved by their partners on the following shift, or until the foreman provides someone to fill their places.

For keeping discipline, and to prevent slackness in the work, certain rules, the result of long experience, have been laid down for the guidance of the men. These are:

The men must be promptly at work, and must work the full time, or (for inside hands) until relieved.

For ten-hour men the working-day is from 7 a. m. to 12 m. and from 1 p. m. to 6 p. m. in summer, while in winter the noon-hour is shortened to 30 minutes, and the day ended at 5:30 p. m.

Inside men must be on hand the entire time of their shift, and must eat their luncheon when there is time while watching their work. Charge wheelers must keep up the supply, even when the furnace is running fast, but may rest at intervals, and are not called upon to do other work than sweeping up at their own places before going off shift. The inside man can leave when relieved by his partner, but must wait for his partner if delayed in arriving. If the latter fails to appear the foreman provides another man, who then holds the place, the absent man losing it unless he has a good excuse, or if sick, he is required to notify the foreman by message, who then provides a man in his place. When the first man desires to return to work he must notify the foreman one shift in advance, so that the substitute is not put out of a shift for which he has come prepared.

When men are sick on shift, if not too seriously, they should be held if possible until the end of the shift. It is impressed upon them that it is detrimental to the work for them to leave, and that it is difficult at short notice to get someone to fill their place.

Men must obey orders, and flat disobedience is followed by discharge, irrespective of who the man may be. Otherwise discipline is weakened.

Be strict but just. It helps in discipline to discharge the poorest man occasionally, and if much time elapses without this you may be sure that you are becoming less strict.

Do not entrust men to do work without supervision and inspection. They do it wrong, or become careless when they realize that they are not watched.

In certain respects metallurgical work differs from that of other industries. The work is carried on by a crew who work together, each man having a part of the operation to depend on him alone. All are directed by the foreman who sees to the regular operation of the mill or furnace. Thus we have about a silver-lead blast-furnace, the feeder and his helper, the weigher, and the wheelers or trammers who bring in the stock, all being men that work on the feed-floor. At the slag or lower-floor there is the furnace-man, the tapper, and the pot-pushers. The men on both floors are called inside men. They work in shifts of 8 to 12 hours, and one crew replaces another. The men are by no means paid an equal wage. The furnace-man or feeder, for example, is paid more than the others, and the pay varies with the skill and knowledge required.

Provision is often made for the care of the men in case of sickness. A charge of one dollar per month holds against every man, and this entitles him to medical attendance and care at a hospital in case of accident. If a man has worked five days in any given month, the one dollar is deducted from his pay for hospital dues.

While accidents occur, especial care is taken by the foreman, for the safety of his men. Men are apt to grow careless and must be warned, or if disobedient, discharged. Any carelessness on the part of the foreman renders the company liable for damages.

The tendency at modern mills and metallurgical works is to reduce the amount of labor per ton of output, this being done by the use of mechanical appliances, so that the labor of the individual becomes less strenuous, less trying to the strength and endurance, and yet better paid. In result, the workman becomes more able and is more desirous of retaining his job, and his services are more reliable. A large mill is run with less labor, proportionally, than a small one. An easily-treated ore requires less labor, since there are few operations and the skill and care is less.

Eight-hour shifts need one-half more men than twelve-hour shifts.

Steam-power requires more labor than water-power, the latter

often requiring only an occasional adjustment of the supply-gate.

In dealing with Mexican employees the American engineer must be scrupulously honest. Honesty, there as elsewhere, is expected of him, and no training nor circumstances alters the restraint he expected to put upon himself. The mining and metallurgical engineer is intrusted with the control of large enterprises and the care of precious metals, and his success depends upon his responsibility.

In starting a new reduction-works, a list of the places and occupations of the men should be prepared, and the men that are engaged are quickly assigned. All men thus engaged should be questioned as to their qualifications, and given places that they can fill. When a new works is to be started, men skilled in the operation and duties apply at the plant and often are willing to accept common labor awaiting the starting of the works. In this way they may be retained until needed.

Quality and cost of labor.—American labor is characterized by intelligence, energy, and responsibility, as compared with Mexican and much foreign labor. Mexicans that have been trained to duties often make excellent inside-men. When well bossed or directed, they do well, though often, from being insufficiently fed, their physical endurance is low. They need watching to prevent them from idling their time, and they should be carefully directed, since they are apt to work at disadvantage on account of their lack of thought. Treat them like grown children, have patience with them, but be judicious and strict. An employer of Mexican labor may find a man that excels in his work. There is a danger that he may be spoiled, by raising his wages. In directing Mexican labor, the familiar style, not the formal or polite one of the books, is to be used. Mexican, and in a less degree, other labor is disposed to pilfer. To such an extent is this true that in Mexico a tool or other portable article can hardly be laid down, without danger of it being stolen.

Men must be held responsible for the tools that are served to them, returning them at night to be locked up. It is also well to brand tools. In the spring, when prospectors everywhere are starting into the hills for their summer occupation, the winter's job is left at the reduction-works, and tools needed in prospecting may be secretly taken.

In determining the rate of wages in a new mining district in Mexico, it is well to start with low pay, as the people have been accustomed to it. It is easy to raise wages later if advisable, but difficult to reduce them when a certain rate has been paid. Among

Mexicans, whose tastes are simple, and wants easily supplied, the result of paying high wages is to give more 'laying-off' time, and this results in inconvenience at the works. Monthly payments interfere with the steady operation of the works, because at the time of the monthly payment the men are disposed to 'lay-off' to spend their money. To overcome the difficulty two methods have been tried. One is that of daily payments, by which a man, who spends his money when he gets it, has only sufficient to supply his daily wants and those of his family, and none remaining for drunkenness or gambling. The other system is to pay a wage to which is added a premium that increases with the time worked. It is paid at the end of the month if the man works through the month, but otherwise not. This tends to keep him steadily at work.

180. DUTIES AT A LARGE GOLD STAMP-MILL.

The men needed will be: Foreman, night foreman, pipe-fitter, two engineers, mill-wright, two firemen, one head amalgamator, four amalgamators, two oilers, two feeders, two laborers.

The foreman has general supervision of the mill, and looks after the handling, cleaning, and retorting of all amalgam collected. The amalgamators dress the chuck-blocks and plates, and keep them in good condition. They set tappets, regulate the water supply, and make renewals. The feeders attend to the uniform feeding of the batteries, and assist the amalgamators in renewals and at the clean-up. A good feeder is a valuable man about a mill. The vanner-men attend to the vanners, or concentrating tables. They must be men with experience, and commonly should first serve at the vanner as 'sulphide-pullers.' The crusher-men feed the crushers with the mine-ore as it comes to the mill. Oilers oil the machinery. Sulphide-pullers remove the concentrate or sulphide from the vanner boxes, and store it for shipment. Engineers run the power-plant, and have charge of the firemen. Firemen fire the boilers and remove the ashes. Coal passers wheel in coal from the coal pile to the boilers.

On repairs there are carpenters, with laborers to help them. In repairs on the vanners there is a special vanner-man to assist.

181. THE ACCOUNTING DEPARTMENT.

This department takes charge of the accounts and transactions, makes up the pay-roll, and attends to the payment of the men. It has also to collect and collate costs.

The costs are prepared for three purposes, as follows:

(a) To enable the owner of the property to judge as to the value and the efficiency of management.

(b) To add to the economy of management by showing where economies can be practised and leaks stopped.

(c) To prevent dishonesty.

Costs are divided into flat, or prime-costs, and general expense, sometimes called fixed charges. The flat-cost varies directly almost with the tonnage, while general expense remains almost constant.

Cost may vary as follows: Flat-costs (per ton of ore put through) diminishes as the output increases. The percentage of labor-cost to general expense is at a minimum in years of average activity. It increases in prosperous times because tonnage is more important than close saving, per ton, and it increases in dull years because general expense must be divided by a smaller tonnage.

The flat-costs include labor, fuel, ^{power, repairs, materials,} ~~operating~~, and supplies.

General expense includes cost of management and superintendence, office force, insurance, indemnities and damages, hospital and medical expenses, taxes and rates, and costs of selling the product.

In connection with the matter of costs there are two further considerations which have a bearing on the returns of the capital invested. These are depreciation of plant, and interest on the invested capital. A plant will depreciate at the rate of 10 to 15% annually, so that even if kept in repair, it will have become obsolete and worn out at the end of ten years. If, however, a company sets aside from the earnings an amount sufficient to put in the needed improvements, and so keeps the plant up to date, then depreciation, except for the buildings, may be disregarded. In case this is not done, then dividends must be sufficient, not only to pay interest on the capital invested, and a profit besides because of the risk involved, but also to meet depreciation. Otherwise the investor is not recovering his capital and the compensation or interest due.

The following are costs often not considered: Expressage on gold or silver bars to the mint or market. Costs of selling, generally a percentage on the gross amount of the sale or the metal costs. Interest on bonds and a sinking fund to meet the payment of the principal when these mature—an expense that must first come out of the profits before the stock-holders are paid a dividend. Home-office expense due to the fact that the office may be in a large city where the stock-holders live, distant from the works. The object of such an office is that the corporate officers and stock-holders

may be in touch with the property in which they have invested. Royalty, when a percentage must be paid for the use of a process.

182. LABOR COSTS.

In a 40-stamp silver amalgamation mill having 24 pans and a capacity of 150 tons of ore per 24 hours the inside labor for that time was:

Four pan-men (12 hours) at \$4.....	\$16
Two helpers (12 hours) at \$3.....	6
Ten tank-men (12 hours) at \$3.....	30
	—————
	\$52

The quoted prices prevail in California and in other high-price camps in the Rocky Mountain region.

Men needed and the cost of labor for a single silver-lead blast-furnace plant for 24 hours, having two 12-hour shifts are as follows:

On feed floor:	Two feeders at \$2.50.....	\$ 5.00
	Two feeder's helpers at \$1.80.....	3.60
	Six charge-wheelers at \$2.40.....	10.80
	Two weighers at \$2.40.....	4.80
On slag floor:	Two furnace-men at \$2.50.....	5.00
	Two tappers at \$1.80.....	3.60
	Four pot-pushers at \$1.80.....	7.20
	Two engine-runners at \$3.50.....	7.00
	Two foremen at \$4.25.....	8.50
Ten-hour men:	Two dump-men at \$1.50.....	3.00
	Four sampling mill-men at \$1.50.....	6.00
	One sampling foreman.....	2.50
Mechanics:	One blacksmith.....	3.00
	One carpenter.....	3.50
		—————
		\$73.50

The above is based on a wage of \$1.50 per day for common labor, and for a minimum force, that must be increased when putting in improvements, or for emergencies. If they can be profitably employed, it is well to have men to supply vacancies caused by sickness, accidents, or men leaving.

The following is the labor cost at the Treadwell stamp-mill, (240 stamps) Douglas Island, Alaska.

Inside men :

One foreman at \$150 per month.....	\$ 5.00	
Four amalgamators (12 hr.) at \$90 per month....	12.00	
Eight feeders (12 hr.) at \$70 per month.....	18.64	
Four vanner-men (12 hr.) at \$65 per month.....	4.34	..
Two sulphide-pullers (10 hr.) at \$2.00.....	4.00	
Two sulphide-shovellers (10 hr.) at \$2.00.....	4.00	
Two engineers (12 hr.) at \$2.50.....	5.00	
Two foremen (12 hr.) at \$2.50.....	5.00	
Two coal passers (10 hr.) at \$2.00.....	4.00	
Four crusher-men (10 hr.) at \$2.25.....	9.00	\$79.66

Repairs:

One carpenter (10 hr.) at \$4.....	\$ 4.00	
One vanner-man (12 hr.) at \$1 per month.....	3.34	
One laborer (10 hr.) at \$2.....	2.00	
		\$ 9.34
		\$90.00

To these labor costs is added, for board and lodging furnished by the company, an actual cost of at least 50c. per man daily.

183. PROFITS.

Profits from the operation of a plant, whether independent or connected with a mine, may be defined as the difference between the total gross costs and the returns on the metal-product sales. The profits may be increased either by better extraction (recovery) from the ore, by economy of treatment due to methods permitting a saving in labor, supplies, or fuel, and by faster running, by which the output is increased.

The profit of a custom works, which buys ores outright, is the difference between the charge made for treatment and the actual cost of treatment. In the early days of smelting at Leadville, Colorado, charges of \$60 per ton were made, the actual cost being \$20, and the profit \$40. Today this margin is as low as \$1 to \$2 per ton because of competition. Another profit is made on extraction. The works makes a deduction for losses in extraction. If they extract more than this, the difference is a clear gain to them. Thus they pay for 95% of the silver in the ore, but if they recover as they generally do, 98%, then the 3% difference is a profit.

We will take, as an example, the profits that may be expected from the following ore:

A. S. K.

Treatment charge per ton.....	\$6.25	
Actual cost " "	4.50	
		\$1.75
Gain in extraction of silver.....	\$0.25	
" " " " gold.....	0.10	
" " " " lead	0.35	
		0.70

This shows a total profit per ton, from both resources. . \$2.45

In milling, this calculation remains the same whether the ore is highly silicious or not, but in smelting the silicious ore would make more slag that would contain more of the metal, and this would diminish the gain in extraction and perhaps convert it into loss.

The following figures represent the profits of a company owning a mine, the Robinson company, on the Rand, South Africa :

Gold recovered at the stamps.....	\$20.50
Gold recovered by cyaniding.....	5.70
	\$26.50
Total recovery.....	\$26.50
Cost of mining.....	\$6.55
Cost of milling.....	0.98
Cost of cyaniding.....	0.97
	\$8.50
Net profits per ton.....	\$17.70

184. THE SELLING DEPARTMENT.

Selling the product of the works is not difficult. There is a ready market for the commercial metal, but advantage can be taken of the market, and there are companies, aside from the producing company, that can be employed to perform this.

185. FUEL AND METAL MARKET.

In examining market quotations of metals we must understand clearly the kind of ton meant. The short ton (2000 lb.) is used in the Western United States for ore and metal. For coal, iron ore, pig iron, and steel the long ton (2240 lb.) is understood, particularly in the Eastern States in the wholesale trade. In England, copper, tin, and spelter are weighed and sold by this ton. On the continent of Europe, in Mexico, and, in fact, wherever the metric system is in use, the metric ton of 2204 lb. is taken, and this approximates to the long ton.

In the United States, New York is the chief market for metals,

and the sale of ore and of metal is based on the prices there. The quotations of other markets, as San Francisco, St. Louis, and London, are also often given. For coal, coke, iron, and steel other centers are understood. Referring to a technical publication, as for example the *Mining and Scientific Press*, of San Francisco, or *The Engineering & Mining Journal* of New York, we find the quotations published. Taking as an example the quotations of September 1908, the necessary explanations are as follows:

Anthracite coal, New York market.—Schedule prices are \$4.75 for broken and \$5 for egg, stove, and chestnut. Steam-size prices are unchanged, pea \$3.25@3.50, buckwheat No. 1, \$2.35@2.50, buckwheat No. 2 or rice, \$1.60@2, barley, \$1.35@1.50. All prices are per long ton f. o. b. (free on board) New York harbor points.

Run of mine anthracite coal is sent to breakers, large buildings containing the necessary crushing machines and revolving screens, to sort or screen the coal to the sizes above specified. The smaller sizes, called 'steam sizes', are cheaper, and are utilized in burning under steam boilers.

Bituminous coal, New York market.—Good grades of steam-coal are quoted at \$2.50@2.65, with the poorer qualities selling around \$2.40. At the mine, bituminous coal is quoted, f. o. b. cars, for run-of-mine, 85c., $\frac{3}{4}$ -in. gas-coal, 90c., and slack at 50c. The $\frac{3}{4}$ -in gas-coal is obtained by screening the slack through a bar-screen having $\frac{3}{4}$ -in. spaces. The coal that drops through the spaces is called slack. The difference between the prices at the mine and at New York represents chiefly the cost of freight to New York.

Coke, Pittsburg market.—At the coke ovens the prices f. o. b. are for furnace coke, \$1.65@1.85, and for foundry coke, \$2.10@2.25. To be well suited for cupola use coke should be firm and in larger pieces than otherwise is required.

Iron ore, market at Lake Erie ports, as Loraine, Cleveland, Conneaut, and Ashtabula.—Old Range bessemer, \$4.50, non-bessemer, \$3.75, Mesabi bessemer, \$4.25, non-bessemer, \$3.50. The difference in price between the Old Range and the Mesabi ore is because the latter is soft and contains much fine, and thus is less acceptable for blast-furnace work. Bessemer ore is low in phosphorus, not to exceed 0.045% phosphorus to 55% iron.

Pig-iron, Pittsburg market (Quotations for carload lots).—Standard bessemer, \$15; malleable bessemer, \$14.50; basic, \$14.25; No. 2 foundry, \$14.50; gray forge, \$13.50. Standard bessemer is used for making steel in the bessemer converter, malleable bessemer for malleable iron castings, basic for steel suited to the basic open-hearth furn-

ace, foundry for making foundry castings suited to machining, and gray forge for wrought-iron. In the Chicago markets, both Southern and Northern pig-iron are quoted. The first, from the great iron center at Birmingham, Alabama, though cheap, is high in phosphorus. The Northern iron from nearby points, is made from Lake Superior ores. Pig-iron, cast in sand, is weighed to 2260 lb. for a long ton, the 20 lb. excess being an allowance for the sand that sticks to the pigs.

Steel, Pittsburg market.—Bessemer and open-hearth billets are quoted at \$25. These are ingots 4 in. square by 6 ft. long that are re-heated and rolled into the required merchant-steel bars. Merchant-steel bars remain at 1.40 to 1.60c. per pound. This is equal to \$31.36 to \$35.84 per long ton. Structural steel includes angles, channels, and I-beams, and is quoted much as are merchant-steel bars. Steel sheets are quoted at 2.50c. for black and 3.35c. per pound galvanized, No. 28 gauge. The 'black' means that the sheets are rolled, but not galvanized. The gauge referred to is the No. 28 wire-gauge, and is the basis from which thickness is reckoned according to a fixed scale. Steel railroad rails are held at \$27. Scrap or old steel material, held at \$10 to \$12 per ton, is added to the charge in basic open-hearth work.

Silver.—At New York the quotations are on silver bars, per troy ounce of silver, 1000 fine. It takes 14.58 troy ounces to make 1 lb. avoirdupois. London prices are for sterling silver, 925 fine. The value of the pound sterling is also given, so that with the London quotation, we may compute the equivalent price in cents there. Let us say that sterling exchange is \$4.86, and that silver is selling at 25 $\bar{1}$ per sterling ounce, we have then:

$$\frac{5}{0} \times 4.86 \times \frac{1000}{925} = \frac{4.86}{240} \times \frac{27}{0.025} = 54.8c. \text{ per ounce of fine silver.}$$

Copper.—The New York price is expressed in cents per pound, quotations being given for Lake copper cast in the form of cakes for rolling into sheets, or ingots for re-melting to make castings, brass, and bronze, or wire-bars for drawing into wire. A sample-quotation is as follows: "The market closes steady at 13 $\frac{5}{8}$ c. for Lake, 13 $\frac{1}{4}$ @13 $\frac{3}{8}$ c. for electrolytic." (Here is noticed a difference of $\frac{1}{8}$ to $\frac{1}{4}$ c. per lb. in favor of Lake copper). "Casting-copper has averaged 13@13 $\frac{1}{8}$ c. during the week." Casting-copper is not as pure as that which is to be rolled into sheets or drawn into wire. Electrolytic copper is made by re-melting cathodes (the product of electrolytic refining) into ingots, cakes, or wire-bars. Cathodes are held at $\frac{1}{8}$ c. less than electrolytic copper, the difference paying for the

re-melting. In London copper is sold by the long ton in English money, and is of various brands. A sample set of prices is as follows:

English tough copper, £63 10s.

Best selected, £62 10s. @ £63 10s.

Standard, £59 17s. 6d. for spot; £60 13s. for 3 months.

The last quotation has reference to whether the copper is for immediate delivery, or whether the customer will take it at the expiration of three months, in which time the reduction-works will have produced it. The making of best-selected copper is mentioned under 'the refining of copper'. Standard copper, formerly called g. m. b. (good merchantable bars), is the grade upon which the others depend. Besides these brands we have:

Strong sheets (rolled copper).....	£72 10s.
India sheets (a rolled brass).....	£68 10s.
Yellow metal (a grade of brass).....	5½d. per lb.

It is the business of dealers, and others interested in copper, to keep statistics of the supply of available copper, which is called the 'visible supply'.

When the visible supply is small the price naturally rises, and the reverse is true when it is large. Manufactured copper is quoted at 19c. per lb. for cold-rolled, and 18c. for hot-rolled, while wire has a basis price of 15¼c. in carload lots at the mill.

Tin.—Like copper, tin is quoted for immediate or for future delivery at a specified time. A sample quotation would be 30¾c. for spot and 29¾ to 30c. for future (three months, for example). The price is the same whether the metal is from Burma, near the Straits of Malacca (Straits tin), from Bolivia, from Australia, or elsewhere. When sold, as in the London market, we quote £134 for spot, and £130 15s. for three months per long ton of 2240 pounds.

Zinc is commercially called spelter. Quotations in the United States are given in cents per pound, thus: 4.60c., St. Louis; 4.75 to 4.80c., New York. The London market is quoted at £19 15s. for good ordinaries (ordinary brands) and £20 for specials (the purer zinc). St. Louis is near the zinc-producing district of Kansas, Missouri, and Illinois, and hence has a lower price for spelter than New York.

Prices for zinc ore are given per short ton at Joplin, Missouri, on a basis for ore assaying 60% zinc, and the price varies with the zinc content above or below this figure. It once was the custom to obtain the basis price per ton in dollars, by multiplying the price of spelter per pound in cents by 7.5, but this is only an approximation, the

buyer often being willing to pay a high price to secure the ore when it is scarce. With zinc quoted at 5c. per pound, the price for zinc ore would be \$37.50.

Antimony.—Sample quotations per pound are, $8\frac{1}{4}$ to $8\frac{1}{2}$ c. for Cookson's, $7\frac{7}{8}$ to $8\frac{1}{8}$ c. for Hallett's, and $7\frac{1}{2}$ to $7\frac{3}{4}$ c. for ordinary brands. The brands named are those of well known smelters of antimony.

Quicksilver.—The New York price is \$42.50 per flask (75 lb. net) for large lots. San Francisco makes nominal prices per flask at \$42 for domestic orders, and \$40 for export. The London price is £8 5s. per flask. Formerly the weight of a flask was $86\frac{1}{4}$ lb., but this has been decreased to 75 pounds.

Precious metals.—Gold is sold to the mints at an unchanging price of \$20.67 per troy ounce, 1000 fine. From this the mint makes a deduction of 2c. per oz. to cover the cost of melting and assaying. Platinum is a commercial metal, at present more valuable than gold. We quote \$22.50 for hard platinum, \$20 for ordinary, and \$16 for scrap. Silver has already been discussed. *Jan 1916 - \$80 to \$90.*

Quicksilver 1916 - ranged from \$125 early in the month to \$300 on Jan 25.

INDEX

	Page.
Accounting department.....	478
Acid bessemer blow.....	444
Refractories	48
Agitation vats.....	211
Alkaline earths in slags.....	383
Amalgam safe.....	227
Amalgamating pan.....	222
Amalgamation	118
Breaking ore for.....	68
Of silver ores.....	218
American ore hearth.....	368
Analyses of coke.....	385
Of copper matte.....	315
Of dolomite.....	383
Of flue dust.....	391
Of fuels. 33, 34, 35, 36, 39, 43, 45	
Of gold ores.....	137
Of iron slags.....	293
Of lead ores.....	361, 362
Of limestone.....	383
Of matte.....	111, 315
Of pig-iron.....	294
Of refractories.. 50, 51, 54, 55	
Of slags.....	382
Of silver precipitate.....	259
Anaconda, Montana, matte smelting	334
Annealing zinc retorts.....	409
Anode-mud	435
Anodes, sampling of.....	65
Anthracite	35
Market	483
Antimony in base bullion....	384
Prices	486
Argentite	217
Arsenic in silver-lead smelting	384
Assayer, duties of.....	474
Augustin process.....	248
Automatic charging of blast- furnaces	276
Feeders	126
Sampling	59
Azurite	298

B.

Bag house.....	392
Barrel chlorination.....	143
Base bullion.....	390
Bullion, sampling of.....	64

	Page.
Metal leaching.....	255
Metal ores.....	18
Bases in slags.....	382
Basic open-hearth process....	444
Refractories	48
Bedding lead ores.....	362, 369
Beehive ovens.....	39
Belt elevators.....	458
Berthelot law.....	22
Bessemer converter.....	442
Iron ores.....	18
Process	441
Best-selected copper.....	332
Betts process.....	448
Black Pine, Nevada, treatment at	243
Blaisdell excavator.....	183
Blake crusher.....	69
Blast for copper.....	303
Roasting	112
Blast-furnace, breaking ore for	66
For silver-lead.....	371
Plant	275
Blende	399
Blister copper.....	332
Blowing engines.... 283, 285, 346	
Blowing-in	286, 377
Bodie, California, treatment at	209
Bone-ash	48, 54
Bornite	297
Bosqui, F. L., acknowledg- ments to	13
Boss process.....	229.
Bottoms, treatment of.....	333
Boulder county, Colorado, gold ores	137
Breaking ore.....	66
Brick kiln.....	49
Machine	53
Mold	52
Briquetting press.....	394
British thermal unit, definition	20
Bromo-cyanogen process.....	210
Brown agitator.....	265
Brown-horseshoe furnace....	97
Brown-O'Harra furnace.....	97
Bruckner furnaces.....	97
Butters distributor.....	182
Filter	186

	Page.		Page.
By-product charcoal.....	37	Chemist, duties of.....	474
Ovens	39, 40	Chemistry of blast-furnace...	381
C.			
Calamine	399	Of cyanide process.....	154
Calciners	92	Of roasting.....	79
Calcing	331	Of roasting zinc ores.....	400
Calculation for matte charge..	324	Chilean mill.....	207
Of charge in pyrite smelt-		Chimneys	28
ing	322	Chlorination	36, 135, 139
Of charge in silver-lead		Chloridizing ores.....	18
smelting	385, 389	Roasting of silver ores....	235
Of iron-furnace charge...	291	Chlorine generator.....	140
California gold ores.....	137	Chrome-iron	48, 51
Stamp-mills	133	Chrysocolla	298
Callow cones.....	178	Cinder from blast-furnace....	286
Calorie, definition.....	20	Classification of cyanidation	
Calorimeters	22	methods	156
Cams	124	Of gold ores.....	115
Cananea ores.....	137	Classifiers	177, 189, 201
Canda cam.....	124	Clean-up at Maitland mill....	203
Canyon City, Colorado, lime-		In Cyanidation.....	170
stone	383	In silver cyanidation....	270
Capacity of roasting furnaces	111	Pan	128
Of stamps.....	133	Coal	31, 34
Carbonates of copper.....	298	Market	483
Carbon-brick	48, 54	Coarse crushing.....	69
Cast-iron refining.....	439	Coke	31, 38
Cast-steel ladle.....	348	In silver-lead smelting....	384
Casting-lead	424	Market	483
Machine	287	Coking coal.....	34
Pig-iron	287	Combination M. & M. Co., treat-	
Centrifugal pump.....	173	ment at.....	243
Cerargyrite	217	Silver mill.....	234
Chalcocite	297	Combustion	24
Chalcopyrite	297	Commercial considerations....	467
Charcoal	36	Composition of matte..	315
In silver-lead smelting...	385	Comstock ores, treatment of...	219
Charge floor in lead smelting..	378	Concentrate, cyanidation of...	209
For zinc smelting.....	407	Definition	18
Scoop for zinc.....	406	Purchase of.....	469
Sheet for iron furnace....	292	Roasting of.....	244
Sheet for matte smelting		Sampling of.....	63
.....	315, 324	Condensers for zinc smelting..	408
Sheet for pyrite smelting.	322	Coning	58
Sheet for silver-lead smelt-		Construction of reverberatory	
ing	387, 389	furnaces	94
Charging cyanidation vats....	164	Work	457
Chemical reactions in blast-		Converter, bessemer.....	442
furnace	288	Plant for copper.....	342
		Converting copper matte.....	336

	Page.		Page.
Conveyor belts.....	461	Cyanide, Colorado, treatment at	205
Copper	295	Cyanidation of gold ores..	135, 151
Converter	336	Of silver ores.....	263
In cyanidation.....	208		
In lead smelting.....	384	D.	
Ingots, sampling of.....	65	Dale, California, process at...	208
Ores, purchase of 469, 471,	472	Dead fluxes.....	386
Quotations	484	Decantation	156, 180, 185
Refining	430	Diehl process.....	210
Sulphides, pot-roasting of.	113	Direct process.....	333
Sulphides, roasting of....	84	Discharging cyanidation vats.	165
Cost at Lexington mill.....	242	Discipline	475
Of chlorination.....	142, 150	Distillation, breaking ore for.	68
Of converting.....	349	Of zinc.....	402
Of cyanidation..	191, 193, 210	Dolomite	48, 54, 383
Of electrolytic refining....	437	Double-discharge mortars....	123
Of gold ore treatment.....	213	Treatment in cyanidation	
Of grinding.....	74	153, 181
Of heap roasting.....	90	Draft in chimneys.....	28
Of labor.....	477, 480	Dressing plates.....	127
Of lixiviation	260	Drop of stamps.....	133
Of mechanical roasting...	111	Dry-crushing, flow sheet for..	73
Of refining base bullion...	430	Silver mill.....	238
Of reverberatory furnaces.	93	Dry ores.....	18
Of roasting in reverbera-		Ores, purchase of.....	469
tories	96	Silver milling	238
Of roasting stalls.....	90	Drying cyanide precipitate...	173
Of Russell process.....	262	Ducktown, Tennessee, smelt-	
Of sampling.....	63	ing practice.....	321
Of silver cyanidation.....	270		
Of silver milling.....	229	E.	
Of smelting lead ores....	395	Edwards furnace.....	97, 101
Of stamp milling.....	134	Electric trolley slag pots....	326
Of zinc smelting.....	410	Electrolyte, circulation of....	437
Cowper stoves.....	281	Purifying	436
Cripple Creek ores.....	137	Electrolytic copper refining...	434
Ores, cyanidation of.....	205	Refining of lead.....	448
Ores, treatment of.....	143	El Oro cyanidation method...	193
Crushing	66	Elevator buckets.....	459
For cyanidation	151	Enargite	298
For patio process.....	246	Endless-chain conveyor.....	462
Lead ores.....	364	Endothermic reactions.....	21
Cupola furnace.....	26	English cupelling furnace....	426
Cupelling	427	Equipment of plant.....	453
Furnace	426	Extraction	19
Cuprite	298	And mesh in cyanidation.	194
Current density in refining...	435	By Russell process.....	262
Cusiuhuiriac, Mexico, treat-		In silver milling.....	235
ment at.....	262	Of copper.....	299

	Page.		Page.
Of copper from copper sulphides	350	Gold bars, sampling of.....	64
Of silver.....	218	Metallurgy of.....	115
Exothermic reactions.....	21	Native	115
F.		Silver, parting.....	439
Faber du Faur retort.....	425	Solution tank.....	168
Feeders	126	Tellurides	115
Filter presses.....	171	Golden Cycle mill.....	207
Pressing	172, 185	Grabs	464
Pressing in cyanidation	156, 188	Grab samples.....	57
Fine crushing.....	72	Grading ore.....	19
Fineness of gold.....	486	Pig-iron	294
Firebrick	51	Graphite	35, 48, 50
Fire-clay	48, 51	Grinding	66, 74
Flash roasting.....	137	H.	
Flow-sheet in Maitland mill...	200	Hand reverberatories.....	92
Of Augustin process.....	249	Sampling	57
Of barrell chlorination....	151	Handling materials.....	457
Of dry-crushing.....	73	Harrisburg, Arizona, treatment at	210
Of lead refining.....	417	Heap-roasting, breaking ore for	67, 84
Of Russell process.....	261	Heat evolved in reactions.....	21
Of Ziervogel process.....	250	Of formation of compounds	23
Flue dust.....	391	Reactions in roasting.....	81
Gases, temperatures.....	28	Hematite	273
Fluorspar in slags.....	383	Henderson process.....	356
Fore-hearth	309	Hersam, E. A., acknowledgments to	14
Foreman, qualities of.....	474	Heyl and Patterson casting-machine	287
Fractional selection of samples	59	Hoffman by-product oven....	41
Free-milling ores.....	18	Hoists	464
Fuel	31, 43	Holthoff furnace.....	97
In silver-lead smelting...	384	Homestake cyanidation methods	188
Market	482	Hot-blast stoves.....	282
Furnace, cupola.....	26	Howard mixer.....	421
English cupelling.....	426	Howard press.....	422
Reverberatory matting....	327	Hunt ammonium process....	208
Wind	26	Hunt and Douglas process	350, 353
Zinc	404	Huntington-Heberlein process.	112
Fuse box.....	93	Hydraulic accumulator.....	347
Fusion of copper ore.....	331	Hydro-metallurgy of copper..	349
G.		Of gold.....	134
Galena	361	Of silver.....	248
Roasting of.....	112	Hyposulphite treatment of silver ores.....	253
Gangue, definition.....	18		
Ganister	48, 49		
Gates tube-mill.....	196		
Genesis of fuels.....	32		
Globe bag house.....	393		
Plant	370		

	Page.		Page.
I.		Mahler calorimeter.....	22
Impurities in lead bullion....	416	Maitland cyanidation mill....	199
Industrial railways.....	464	Malachite	298
Ingots, sampling of.....	64	Manganese in slags.....	382
Installation of plants.....	455	Market lead.....	420
Iron in slags.....	382	Matte	314
Ore, market.....	483	Analyses of.....	111
Ores	273	Composition of.....	315
Ores, purchase of.....	469	Concentration	324
J.		Heap-roasting of.....	87
Jeffrey elevators.....	459	Lead copper.....	395
K.		Smelting	302, 304
Kiln, brick.....	49	Smelting at Anaconda.....	334
For making charcoal....	37	Smelting, charge sheet...	316
Krupp ball-mills.....	137	Treatment by Augustin	
L.		process	249
Labor costs.....	480	Treatment by Ziervogel,	
Lake copper, refining.....	433	process	250
Lathe for cutting zinc.....	169	Matting blast-furnace.....	303
Leaching base metals.....	255	McArthur-Forrest process	135, 152
Grinding ore for.....	68	McDougall furnace ...	91, 97, 108
In cyanidation.....	159, 165	Mechanical roasters.....	97
In Ziervogel process....	252	Melacnite	298
Ores	18	Melting furnace for silver...	228
Silver ores.....	257	In lead.....	378
Lead bullion, refining.....	415	Lake copper.....	433
Copper matte.....	395	Lead ores.....	364
Electrolytic refining....	448	Silver residues.....	245
Ores	361	Mercur, Utah, cyanidation	
Ores, purchase of.....	469	method	156
Leadville ores.....	361	Mercury, see quicksilver.....	
Lexington mine, treatment at.	241	Merton furnace.....	97
Lignite	33	Mesh and extraction in cyan-	
Limestone	383	idation	194
Lining converters.....	341	Metal market.....	482
Lixiviation of silver ore.....	253	Metallic Extraction Co., treat-	
Location of works.....	453	ment	205
Loomis-Pettibone gas-producer.	45	Metallics, sampling.....	63
Loss in converting copper....	349	Metallurgical treatment of ores	19
In distilling zinc.....	409	Metallurgy of zinc.....	400
Losses in roasting.....	111	Metals, sampling of.....	64
Lump, ore, roasting of.....	84, 89	Mill-sites	455
M.		Missouri dolomite.....	383
Machine sampling.....	59	Moisture sample.....	57
Magnesite	48, 54	Molding market lead.....	424
Magnetite	273	Monadnock mill.....	207
		Mount Morgan ores, treatment	
		of	137
		Muffle roasting furnace.....	358

	Page.		Page.
N.			
Native copper.....	298	Pig-iron, market.....	483
Silver	217	Sampling of.....	66
Natural gas.....	31, 36	Smelting	274
Solid fuels.....	33	Pipe sampler.....	60
Neill process.....	355	Pittsburg markets.....	483
New York metal market.....	483	Plant and equipment.....	453
Nitric-acid parting.....	439	Plattner process.....	135, 139
Non-bessemer iron ores.....	18	Plumbago	50
O.		Polybasite	217
Open-hearth process.....	444	Pot-roasting	112
Operating department.....	473	Pound-calorie, definition.....	20
Operation of bessemer conver- ter	443	Precipitation after chlorination	148
Of blast-furnace	283	After lixiviation.....	258
Of converters	338	At Maitland mill.....	203
Of copper furnace	86	In cyanidation.....	169, 191
Of lead smelting	368	Preparation of ores.....	19
Of reverberatories	94	Prices of pig-iron.....	294
Of stamp-battery	125	Producer gas.....	43
Ore-buying schedules.....	469	Profits	481
For matte furnace.....	312	Properties of zinc.....	399
Hearth	368	Puddling	441
Ores, classification of.....	17	Pulp, sampling of.....	63
Definition of.....	17	Pulverized ore, roasting of...	91
Mixed	17	Punch sampling.....	65
Of copper	297	Purchase of ores.....	468
Of gold	117	Push conveyor.....	463
Of iron	273	Pyrite matte smelting.....	318
Of lead	361	Roasting	79
Of silver	217	Smelting in two stages..	321
Of zinc	399	Q.	
Simple	17	Quality of labor.....	477
Organization of metallurgical company	467	Quartering	58
Oxidation of lead ores.....	366	Quicksilver fed to battery...	126
Oxides of copper.....	298	In silver milling.....	244
Oxidizing roasting.....	79	Prices	486
P.		Trap	127
Parkes process.....	420	Quotations of metals.....	482
Parting gold-silver.....	439	R.	
Patera process.....	253	Rabbles in Edwards furnace..	107
Patio process.....	246	Rand cyanide practice 153,	156, 180
Pattison process.....	419	Raymond furnace.....	97
Pearce-turret furnace 97, 104,	137	Reactions in basic open-hearth process	447
Peat	33	In bessemer converter...	444
Petroleum as fuel.....	31, 35	In blast-furnace	283, 288
		In bromo-cyanidation ...	213
		In chlorination	141

	Page.		Page.
Ores	18	Treadwell stamp-mill, costs at	480
Silver-lead ores.....	369	Trench sampling.....	58
Zinc ores.....	402	Tripper	461
Softening furnace.....	418	Trommel	74
Lead bullion.....	416	Tube-mills	75, 196
Sombrerete, Mexico, treatment		Tuyere	311
at	262		
Specific heat.....	30	U.	
Speiss	384	Unskilled labor.....	475
Spelter refining.....	437		
Sphalerite	399	V.	
Spitzkasten	177	Vacuum-filtration in cyanida-	
Split shovel.....	59	tion	156, 185
Stacks	28	Vats for cyanidation.....	160
Stall-roasting, breaking ore		For hyposulphite leaching	256
for	67, 84	Vezin sampler.....	60
Stamp-mills	118	Vibrating trough conveyor....	463
Men for.....	478		
Stamper	406	W.	
Standard plant, Bodie, Cali-		Washoe process.....	219
fornia	209	Water-jackets	307, 375
Starting blast-furnace.....	312	Weighing ore.....	56
Steel cyanidation vats.....	163	Weight of stamps	133
Making	441	Welsh process.....	330
Market	484	Western Australia ore treat-	
Stephanite	217	ment	210
Stetefeldt furnace	97	Wet pan.....	345
Stirring paddle.....	430	Silver mill	220
Suction filtration.....	185	Wethey furnace.....	97, 100
Sulphatizing roasting of matte	251	White briquetting press. 206,	394
Sulphide ores.....	18	White-Howell roaster. 97, 137,	239
Roasting	79	White metal.....	332
Sulphuric-acid parting.....	439	Wind furnace.....	26
Supplies, purchase of.....	472	Wood	32
		Wooden cyanidation vats....	161
T.		Wrought-iron manufacture... 440	
Tailing, leaching of.....	159		
Purchase of.....	469	Z.	
Sampling of.....	63	Zince boxes.....	167
Taylor gas-proucer.....	44	Furnace	404
Tellurides of gold.....	115	In slags.....	383
Temperature of combustion... 29		Lathe	169
Testing current for refining.. 437		Metallurgy of.....	400
Tetrahedrite	298	Ores	399
Thermo-chemistry	20	Quotations	485
Time in cyanidation.....	167	Zone of fusion in blast-furnace	284
Tin quotations.....	485	Of preparation in blast-	
Tram tracks.....	464	furnace	284
Traveling cranes.....	464	Of reduction in blast-fur-	
		nace	284



YC 68411

404258

TN
665
A8
1909

THE UNIVERSITY OF CALIFORNIA LIBRARY

