

DEPARTMENT OF THE INTERIOR, CANADA  
FORESTRY BRANCH

---

UC-NRLF



B 3 372 788

# METHODS OF COMMUNICATION

ADAPTED TO FOREST PROTECTION

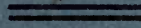

OTTAWA  
THOMAS MULVEY  
PRINTER TO THE KING'S MOST EXCELLENT MAJESTY  
1920

*Price, \$1.00.*

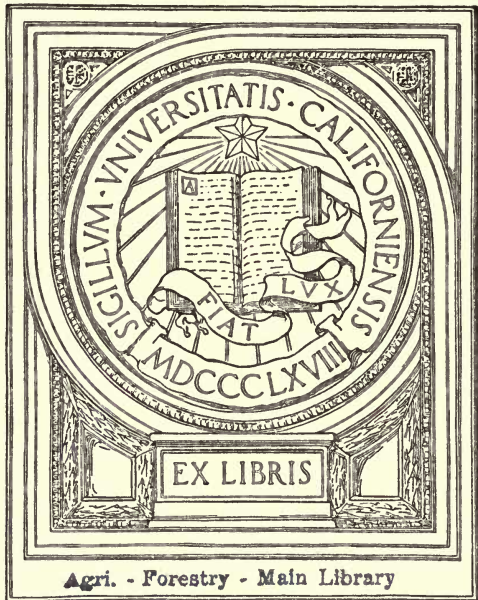

Agri. - Forestry - Main Library

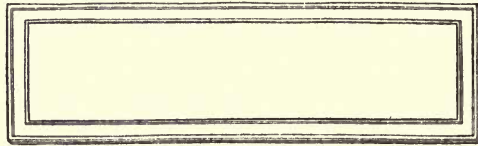





DEPARTMENT OF THE INTERIOR, CANADA  
FORESTRY BRANCH

---

UNIV. OF  
CALIFORNIA

# METHODS OF COMMUNICATION

ADAPTED TO FOREST PROTECTION

BY  
W. N. MILLAR, B.S, M.F.

---

OTTAWA  
THOMAS MULVEY  
PRINTER TO THE KING'S MOST EXCELLENT MAJESTY  
1920.

SD411  
MS

Library of  
Congress

Agri. - Forestry - Main Library

## ACKNOWLEDGMENT

The methods of forest telephone construction described in this manual have been adopted almost without change from the "Instructions for Forest Officers" as issued by the United States Forest Service, Department of Agriculture, in its publication entitled "Telephone Construction and Maintenance on the National Forests." With the permission of the Forest Service a considerable portion of these instructions has been reprinted herein and forms the bulk of Chapters VII, VIII, IX, XI, XII, and XVI, as well as parts of other chapters. Most of the diagrams illustrating telephone construction methods are also reproduced from the same publication. A few were adapted from a special circular of instructions prepared by the District Forester, District 5, United States Forest Service and certain material in the text was secured from the same circular.

Other important publications from which material has been derived are the following: "Systematic Fire Protection in the California Forests," Dubois; "Fire Protection in District 1," Silcox; "Manual of Visual Signalling," United States Signal Corps; "Training Manual—Signalling 1915," British War Office.

In only a few cases, however, has it been possible to quote. In addition, a large number of works on special phases of the subject have been consulted and these are for the most part included in Appendix B.

Personal assistance of the greatest value has also been received from Mr. E. H. Finlayson, District Inspector of Forest Reserves for Alberta, who has aided in the determination of the general plan of the manual and has particularly assisted by criticism of Chapter XIV; from Mr. R. B. Adams, Telephone Engineer, United States Forest Service, Missoula, Montana, who has offered many valuable suggestions and furnished much of the material contained in Chapters X and XIII; from Mr. J. B. Somers, United States Forest Service, in connection with the use of the heliograph and flag by the Service, and from many field officers of the United States Forest Service and the Dominion Forestry Branch with whom the author has been associated in forest administration.

982320

## ABBREVIATIONS

- A. W. G.=American Wire Gauge (Brown & Sharpe)
- B. B.=Best Best iron wire
- B. & S.=Brown & Sharpe wire gauge
- B. I. G.=British Imperial Gauge
- B. S. M. G.=Birmingham Sheet Metal Gauge
- B. W. G.=Birmingham Wire Gauge
- D. B.=Double-Bitted, as of an axe
- D. F. B.=Dominion Forestry Branch
- E. B. B.=Extra Best Best iron wire
- E. M. F.=Electro-Motive Force
- N. B. S. G.=New British Standard Gauge
- S. B.=Single-Bitted, as of an axe
- U. S. S. M. G.=United States Sheet Metal Gauge



# CONTENTS

Introduction . . . . .	Page XV
------------------------	------------

## Part I—Communication in Specialized Forest Protection

### CHAPTER I—SPECIALIZED FOREST PROTECTION.

Sec.		
1	Specialization Defined . . . . .	1
2	Communication Defined . . . . .	2
3	Present Protection Methods . . . . .	2
4	Analogy to Military Operations . . . . .	3
5	Functions of a Forest Protection Force . . . . .	3
6	Prevention of Forest Fires . . . . .	4
7	Detection of Forest Fires . . . . .	5
8	Suppression of Forest Fires . . . . .	7
9	Supervision of Protection Forces . . . . .	8
10	Duties of Supervising Officers . . . . .	8
11	Duties of Suppression Staff Officers . . . . .	10
12	Duties of Suppression Line Officers . . . . .	12
13	Value of Communication System in Field Operation . . . . .	13

### CHAPTER II—METHODS OF CONVEYING INFORMATION TO A DISTANCE.

14	Variety of Methods Available . . . . .	14
15	Types of Visual Signals . . . . .	14
16	Types of Audible Signals . . . . .	15

### CHAPTER III—ADAPTING COMMUNICATION METHODS TO SPECIALIZED FOREST PROTECTION

17	Speed and Certainty in Communication Essential . . . . .	17
18	Method Must be Adapted to Conditions of Use . . . . .	17
19	Control Units Requiring Intercommunication Facilities . . . . .	17
20	Communication Requirements of Control Units . . . . .	19
21	Superiority of the Telephone Evident . . . . .	20
22	Auxiliary Methods Often Required . . . . .	20

## Part II—Forest Protection Telephone Lines

### CHAPTER IV—PLANNING THE TELEPHONE SYSTEM

23	Importance of Preliminary Plans . . . . .	23
24	Plans Must Be Based on Definite Area . . . . .	23
25	Primary Stations Requiring Service . . . . .	23
26	External Versus Internal Systems . . . . .	24
27	Connections to Lookout Stations . . . . .	26
28	Test Stations . . . . .	26
29	Relay Stations . . . . .	26
30	Alternative Routes . . . . .	26
31	Secondary Strategic Points . . . . .	27

## CHAPTER V—SELECTING THE TYPE OF CONSTRUCTION

Sec.	Page
32 Pole-line Construction.. . . . .	27
33 Tree-line Construction.. . . . .	27
34 Construction Methods Contrasted.. . . . .	28
35 Relative Cost of Different Types.. . . . .	28
36 Sketch of the Development of Tree-line Methods.. . . . .	29
37 Influence of Timber Conditions on Choice of Construction Type.. . . . .	30
38 Grounded Versus Metallic Circuits.. . . . .	32

## CHAPTER VI—TELEPHONE CONSTRUCTION POLICY IN DOMINION FOREST RESERVES

39 Construction by the Forestry Branch.. . . . .	33
40 Co-operative and Private Lines.. . . . .	33
41 Use of Forestry Branch Lines.. . . . .	34
42 Telephone Improvement Plans.. . . . .	35
43 Standard Methods.. . . . .	35
44 Standard Materials.. . . . .	36

## CHAPTER VII—OPERATIONS PRELIMINARY TO CONSTRUCTION

45 Factors Influencing Location.. . . . .	42
46 Survey of Route.. . . . .	42
47 Securing Right of Way.. . . . .	42
48 Clearing Right of Way.. . . . .	41
49 Transportation and Distribution of Materials.. . . . .	45
50 Organization and Equipment of Construction Crews.. . . . .	46

## CHAPTER VIII—POLE-LINE CONSTRUCTION

51 Selection of Poles.. . . . .	47
52 Skidding and Seasoning.. . . . .	47
53 Preservative Treatment.. . . . .	47
54 Length of Poles.. . . . .	49
55 Erection of Poles.. . . . .	49
56 Bracing and Guying.. . . . .	54
57 Line Construction.. . . . .	59

## CHAPTER IX—TREE-LINE CONSTRUCTION

58 General Principles.. . . . .	68
59 Selecting Trees and Route.. . . . .	68
60 Line Construction.. . . . .	69

## CHAPTER X—EMERGENCY LINES, CONSTRUCTION AND USE

61 Use in Forest Protection.. . . . .	74
62 Line Construction.. . . . .	74
63 Maintenance.. . . . .	76
64 Taking up Wire .. . . . .	76

## CHAPTER XI—FOREIGN LINES, CROSSINGS, AND CONNECTIONS

65 Location on Poles of Foreign Lines.. . . . .	78
66 Crossings.. . . . .	78
67 Connecting Forestry Branch Lines with Private Lines or Exchanges.. . . . .	82
68 Branch Lines.. . . . .	82

CHAPTER XII—INSTALLATION OF FIXED EQUIPMENT

Sec.		Page
69	Wall Sets . . . . .	85
70	Condensers . . . . .	85
71	Dry Batteries . . . . .	85
72	Protectors . . . . .	88
73	" Grounds " . . . . .	90
74	Wiring . . . . .	92
75	Lookout Station Telephone Sets . . . . .	94
76	Howler and Condenser for Vibratory Signalling . . . . .	96
77	Coils . . . . .	98
78	Special Installations . . . . .	99

CHAPTER XIII—INSTALLATION OF TEMPORARY EQUIPMENT

79	Types of Portable Sets . . . . .	107
80	Forestry Branch Portable Telephone . . . . .	108
81	Adams Hand Set . . . . .	110
82	Emergency Communication Kits . . . . .	114
83	Temporary Connection to Permanent Lines . . . . .	115

CHAPTER XIV—MAGNETO TELEPHONE

84	Introduction . . . . .	117
85	Definition of Electrical Terms . . . . .	118
86	Parts of the Magneto Telephone . . . . .	121
87	Methods of Connecting Telephones to Line . . . . .	137

CHAPTER XV—OPERATION

88	Operating Rules . . . . .	140
89	Code Signalling . . . . .	140

CHAPTER XVI—MAINTENANCE

90	General Principles . . . . .	142
91	Line . . . . .	142
92	Apparatus . . . . .	145
93	" Trouble " . . . . .	152

CHAPTER XVII—TELEPHONE " DON'TS "

94	Construction . . . . .	157
95	Installation . . . . .	158
96	Operation . . . . .	158
97	Maintenance . . . . .	159

Part III—Forest Protection Heliographs and other Signalling Apparatus

CHAPTER XVIII—HELIOGRAPH

98	The Instrument . . . . .	160
99	Use in Forest Protection . . . . .	160
100	Range and Speed . . . . .	161
101	Types of Heliographs . . . . .	162
102	Heliographs at Lookout Stations . . . . .	165
103	Heliographs on Patrol Routes . . . . .	169

CHAPTER XIX—USE OF THE GODWIN HELIOGRAPH

Sec.	Page
104 Parts of the Instrument.. . . . .	169
105 Using the Godwin Heliograph.. . . . .	170

CHAPTER XX—SIGNALLING WITH THE HELIOGRAPH

106 Selecting a Station.. . . . .	173
107 Position of Operator.. . . . .	173
108 Maintenance of Adjustment.. . . . .	174
109 Opening Communication.. . . . .	174
110 Working at Short Ranges.. . . . .	175
111 Working Through Haze and Smoke.. . . . .	175
112 Heliograph Codes.. . . . .	175
113 Instructions to Operators.. . . . .	179
114 Care of Instruments.. . . . .	180
115 Training Operators .. . . . .	180
116 Heliographing by Moonlight and Artificial Light.. . . . .	181

CHAPTER XXI—NIGHT SIGNALLING

117 Signalling Lanterns.. . . . .	182
-----------------------------------	-----

CHAPTER XXII—FLAG

118 General Remarks.. . . . .	186
119 Equipment Required.. . . . .	186
120 Range and Speed.. . . . .	186
121 Use in Forest Protection.. . . . .	187

CHAPTER XXIII—USING THE FLAG

122 General Remarks.. . . . .	188
123 Selecting a Station.. . . . .	188
124 Wigwag Signalling.. . . . .	189
125 Rules for Operators and Conventional Signals.. . . . .	191
126 Wigwag Codes .. . . . .	191
127 Semaphore Signalling.. . . . .	191

CHAPTER XXIV—MESSAGE CODES

128 Purpose of Codes.. . . . .	194
129 Use in Forest Protection.. . . . .	194
130 Combinations Available.. . . . .	194

CHAPTER XXV—DANGER SIGNALS

131 Risk in Fire-fighting.. . . . .	195
132 Use of Danger Signals.. . . . .	195
133 Code of Danger Signals.. . . . .	195
134 Miscellaneous Uses of Shot and Whistle Signals.. . . . .	196

## Appendices

### APPENDIX A—OUTFIT FOR TELEPHONE CONSTRUCTION CREW

	Page
1 Ten-man Crew for Telephone Construction.. . . . .	196
2 List of Line Supplies.. . . . .	197
3 List of Station Supplies.. . . . .	197
4 List of Construction Tools.. . . . .	197
5 List of Tentage.. . . . .	198
6 List of Provisions.. . . . .	198
7 List of Kitchen Equipment.. . . . .	198

### APPENDIX B—USEFUL BOOKS OF REFERENCE

1 Science of Telephony.. . . . .	199
2 Line Construction.. . . . .	199
3 Preparation and Preservation of Poles.. . . . .	200
4 Military Signalling and Telephony.. . . . .	200
5 Telephone Troubles.. . . . .	200
6 Specialized Forest Protection.. . . . .	200
7 Periodicals.. . . . .	201
8 Trade Catalogues and Handbooks.. . . . .	201

### APPENDIX C—TELEPHONE COSTS

1 Factors Involved in the Estimation of Costs of Pole and Tree Telephone Lines.. . . . .	201
2 Approximate Costs of Supplies and Average Time Required for Various Operations in Telephone Line Construction.. . . . .	202

### APPENDIX D—RULES FOR WIRES CROSSING RAILWAYS AND TRANSMISSION LINES

Order No. 231 Board of Railway Commissioners of Canada.. . . . .	203
--	-----

### APPENDIX E—FORESTRY BRANCH STANDARD SPECIFICATIONS

1 Specifications for Galvanizing.. . . . .	209
2 Specifications for Galvanized-iron Telephone Wire.. . . . .	210
3 Specifications for Hard-drawn Copper Telephone Wire.. . . . .	211
4 Specifications for Emergency Wire.. . . . .	211
5 Specifications for Rubber-covered Wire.. . . . .	212
6 Specifications for Glass Insulators.. . . . .	213
7 Specifications for Split Tree Insulators.. . . . .	214
8 Specifications for Poles.. . . . .	215
9 Specifications for Wooden Spools for Emergency Wire.. . . . .	217
10 Specifications for Creosote.. . . . .	217
11 Specifications for Wooden Brackets.. . . . .	218
12 Specifications for Outdoor Protector Mounting-boxes.. . . . .	219

### APPENDIX F—SOLDERING

Methods and Materials.. . . . .	219
---------------------------------	-----

APPENDIX G—USEFUL TABLES.

	Page
1 Weight of Cedar Poles of Various Lengths and Top Diameters . . . . .	221
2 Number of Poles of Different Sizes Required to Make up a Carload Lot..	221
3 Comparison of Wire Gauges.. . . . .	222
4 Tensile Strength of Bare Copper Wire.. . . . .	223
5 Properties of Hard-drawn Copper Telephone and Telegraph Wire.. . . . .	223
6 Properties of Bimetallic Wire.. . . . .	224
7 Properties of Galvanized Telephone and Telegraph Wire.. . . . .	224
8 Properties of Galvanized Steel Wire.. . . . .	225
9 Properties of Rubber-covered, Lead-incased Copper Cables.. . . . .	225
10 Properties of Standard Wire for Telephone Construction on Dominion Forest Reserves.. . . . .	226
Index.. . . . .	227

## Illustrations

Fig.	Page
1 Lookout station on a Dominion forest reserve in British Columbia . . . . .	5
2 Steel lookout tower on a Dominion forest reserve in Saskatchewan. . . . .	6
3 External telephone system on a forest reserve. . . . .	24
4 Internal telephone system on a forest reserve. . . . .	25
5 Mobley wire-cradle as used with two coils. . . . .	43
6 Mobley wire-cradle as used with one coil. . . . .	43
7 Mobley wire-cradle. . . . .	44
8 Klondike pack-frame as used for packing wire. . . . .	45
9 Pole-steps. . . . .	51
10 Location of brackets on pole. . . . .	51
11 Definition of rake. . . . .	53
12 Definition of pull. . . . .	53
13 Setting a pole. . . . .	54
14 Method of bracing . . . . .	55
15 Method of guying. . . . .	56
16 Rock guy bolt. . . . .	57
17 Method of using guy stub. . . . .	58
18 Method of ground bracing. . . . .	58
19 Tripod line supports. . . . .	59
20 Home-made reel. . . . .	61
21 Transposition of wires, metallic circuit. . . . .	62
22 Method of making regular tie for iron wire. . . . .	64
23 Method of making "figure 8" tie for iron wire. . . . .	64
24 Method of dead-ending iron wire. . . . .	65
25 Method of dead-ending hard-drawn copper wire. . . . .	65
26 Method of making regular tie for hard-drawn copper wire. . . . .	66
27 Method of making "figure 8" tie for hard-drawn copper wire. . . . .	67
28 Method of splicing iron wire (Western Union joint). . . . .	67
29 Method of splicing hard-drawn copper wire. . . . .	67
30 Zigzag system of alignment. . . . .	69
31 Reverse curve system of alignment. . . . .	69
32 Split tree insulator attachment and crosstie. . . . .	71
33 Method of dead-ending on tree lines. . . . .	72
34 Method of tying up emergency wire. . . . .	75
35 Method of making temporary splice in emergency wire. . . . .	77
36 Emergency wire reel, open and folded. . . . .	77
37 Method of crossing transmission lines. . . . .	79
38 Method of connecting branch line to main line when both are galvanized-iron wire. . . . .	82
39 Method of connecting branch line to main line when both are hard-drawn copper wire. . . . .	83
40 Method of connecting branch line to main line in tree construction. . . . .	84
41 Wiring diagram of standard wall set. . . . .	86
42 Standard telephone installation. . . . .	87
43 Method of connecting dry cells for a telephone. . . . .	87
44 Method of installing line fuse when required. . . . .	88
45 Wiring diagram for telephone station. . . . .	90

Fig.	Page
46 Method of making entry to building from main line.. . . . .	93
47 Wiring diagram of lookout station telephone set.. . . . .	95
48 Lookout station telephone set installed in the field.. . . . .	96
49 Method of connecting lookout station telephone to line and ground.. . . . .	97
50 Method of connecting howler and condenser.. . . . .	98
51 Method of installing lavite coil to drain line of static electricity.. . . . .	99
52 Method of installing a repeating coil on a pole.. . . . .	100
53 Legend.. . . . .	101
54 Switching station, first method.. . . . .	102
55 Switching station, second method.. . . . .	102
56 Wiring and connections on 47-A repeating coil.. . . . .	103
57 Phantom circuit.. . . . .	104
58 Connecting grounded line to metallic line through a repeating coil without switches.. . . . .	105
59 Connecting grounded line to metallic line by use of switches and two telephones.. . . . .	105
60 Connecting grounded line to metallic line by use of switches and one telephone.. . . . .	106
61 Method of using one wire for simultaneous telegraphy and telephony.. . . . .	107
62 Forestry Branch portable telephone set (1375-A).. . . . .	109
63 Wiring diagram of Forestry Branch portable telephone.. . . . .	110
64 Adams hand set (1004-A) with carrying case.. . . . .	111
65 Wiring diagram of the Adams' hand set (1004-A).. . . . .	111
66 Forest officer preparing to use the Adams hand set with Cree knife for ground rod.. . . . .	113
67 Forestry Branch emergency communication kit No. 1-A.. . . . .	114
68 Wiring diagram of No. 1-A kit.. . . . .	115
69 Forest ranger using the No. 1-A emergency kit.. . . . .	116
70 Bipolar hand receiver.. . . . .	122
71 Longitudinal section of bipolar receiver.. . . . .	122
72 Diagram of telephone circuit, first stage.. . . . .	122
73 Solid-back transmitter and transmitter arm.. . . . .	124
74 Details of the solid-back transmitter.. . . . .	124
75 Diagram of telephone circuit, second stage.. . . . .	124
76 Telephone induction coil.. . . . .	126
77 Diagram of telephone circuit, third stage.. . . . .	126
78 Magneto generator, five-bar.. . . . .	127
79 Polarized ringer, unbiased type.. . . . .	128
80 Telephone switch-hook.. . . . .	130
81 Rolled condenser.. . . . .	131
82 Howler.. . . . .	132
83 Lightning protector for use where there are no power or light wires.. . . . .	133
84 Protector with fuses for use where there are power or light wires.. . . . .	134
85 Baby knife-switches: (a) Single pole, single throw (S.P.S.T.); (b) Double pole, double throw (D.P.D.T.).. . . . .	135
86 Method of inserting a metallic circuit section in a grounded line to overcome induction disturbances.. . . . .	136
87 Diagram of a phantom circuit.. . . . .	136
88 Telephones connected in series on a metallic line.. . . . .	138
89 Telephones connected in series on a grounded line.. . . . .	138
90 Connecting bridging telephone on a grounded line.. . . . .	139
91 Connecting bridging telephone on a metallic line.. . . . .	139
92 Method of installing test station indoors.. . . . .	143
93 Method of installing a test station on a tree.. . . . .	144
94 Stub reinforcement of poles.. . . . .	146



Fig.	Page
95 Receiver test . . . . .	148
96 Ringer of No. 127-F extension bell and Nos. 1317-P, 1317-S, 300-N, and 1336-J telephones . . . . .	151
97 Wiring of No. 1317 telephone set . . . . .	153
98 British Army type of heliograph, one-mirror . . . . .	162
99 British Army type of heliograph, two-mirror . . . . .	163
100 American Army type of heliograph, one-mirror . . . . .	164
101 American Army type of heliograph, two-mirror . . . . .	164
102 Forest Service type of heliograph, one-mirror . . . . .	166
103 Forest Service type of heliograph, two-mirror . . . . .	167
104 Map of California national forest showing heliograph system . . . . .	168
105 Forest ranger sending message by heliograph . . . . .	171
106 Acetylene signal lantern with tripod . . . . .	183
107 Fischer high-power electric signalling lamp . . . . .	184
108 Initial position in flag signalling . . . . .	189
109 "Dot" or motion "1" in flag signalling . . . . .	190
110 "Dash" or motion "2" in flag signalling . . . . .	190
111 Semaphore alphabet, numerals, and special signs . . . . .	192
112 Two-arm fixed semaphore code . . . . .	193
Design of Forestry Branch standard pony glass insulator . . . . .	214
Design of Forestry Branch standard split tree insulator . . . . .	215
Design of Forestry Branch standard emergency wire spool . . . . .	217
Design of Forestry Branch standard wooden bracket . . . . .	218
Design of outdoor protector mounting-box . . . . .	219

1. The first part of the report deals with the general situation of the country and the progress of the war. It is a very interesting and informative account of the events of the year.

2. The second part of the report deals with the military operations of the army. It is a very detailed and accurate account of the campaigns and battles of the year.

3. The third part of the report deals with the political and diplomatic situation of the country. It is a very clear and concise account of the events of the year.

4. The fourth part of the report deals with the economic and social situation of the country. It is a very thorough and well-researched account of the events of the year.

5. The fifth part of the report deals with the cultural and intellectual life of the country. It is a very interesting and well-written account of the events of the year.

6. The sixth part of the report deals with the foreign relations of the country. It is a very clear and concise account of the events of the year.

7. The seventh part of the report deals with the internal affairs of the country. It is a very thorough and well-researched account of the events of the year.

8. The eighth part of the report deals with the military operations of the army. It is a very detailed and accurate account of the campaigns and battles of the year.

9. The ninth part of the report deals with the political and diplomatic situation of the country. It is a very clear and concise account of the events of the year.

10. The tenth part of the report deals with the economic and social situation of the country. It is a very thorough and well-researched account of the events of the year.

11. The eleventh part of the report deals with the cultural and intellectual life of the country. It is a very interesting and well-written account of the events of the year.

12. The twelfth part of the report deals with the foreign relations of the country. It is a very clear and concise account of the events of the year.

13. The thirteenth part of the report deals with the internal affairs of the country. It is a very thorough and well-researched account of the events of the year.

14. The fourteenth part of the report deals with the military operations of the army. It is a very detailed and accurate account of the campaigns and battles of the year.

15. The fifteenth part of the report deals with the political and diplomatic situation of the country. It is a very clear and concise account of the events of the year.

16. The sixteenth part of the report deals with the economic and social situation of the country. It is a very thorough and well-researched account of the events of the year.

17. The seventeenth part of the report deals with the cultural and intellectual life of the country. It is a very interesting and well-written account of the events of the year.

18. The eighteenth part of the report deals with the foreign relations of the country. It is a very clear and concise account of the events of the year.

19. The nineteenth part of the report deals with the internal affairs of the country. It is a very thorough and well-researched account of the events of the year.

20. The twentieth part of the report deals with the military operations of the army. It is a very detailed and accurate account of the campaigns and battles of the year.

## INTRODUCTION

This manual has a twofold purpose. Primarily, it is intended for the instruction and guidance of those officers of the Dominion Forestry Branch who are charged with the protection of the forest reserves and other Dominion-owned timber and who find rapid and reliable means of communication an indispensable adjunct to their work. In order to fulfil this purpose, the various methods of communication which experience has demonstrated to be best adapted for use in forest protection are dealt with in detail, and the methods herein set forth are to be followed without deviation wherever permanent lines of communication are established.

Particular attention is given to instructions for the building of forest telephone lines. In some important respects these lines possess unique characteristics. The distinctive requirements of telephone communication for forest protection purposes have been the subject of much intensive study and experiment during the past decade both in Canada and the United States, and the equipment and methods of construction which have been adopted or developed have been standardized by the United States Forest Service and adopted by many state and private forest protection organizations in both countries. These standard methods with slight modification to fit Canadian conditions are set forth in detail in this manual and form the main body of the portion devoted to the telephone.

It is felt, however, that information with regard to the usefulness of the telephone and other means of rapid communication in forest protection is of timely interest to all owners of timber in Canada. Thus far, there has been relatively little specialization in the work of forest protection on Canadian timber-lands. The usual system followed by both government and private owners has been to send out each year a large number of fire rangers, each of whom works on a more or less independent basis. In many cases a new crew is raised each year and in most cases dependence is placed on chance and the native ability of the rangers for the prevention, detection, and suppression of fires in their districts, without aid from special training, organization, or equipment. There are a few notable exceptions to this practice but as a general rule forest protection in Canada is handled by forces wholly lacking the training, organization, or equipment necessary for the employment of modern specialized methods and is, therefore, of necessity, costly and inefficient.

One of the prime essentials in the organization of fire protection on a specialized basis, in contrast to the present non-specialized methods, is a reliable means of rapid communication linking up all strategic points within the forest with those outside of it and forming a network of lines of communication by which every unit of its protection staff is in constant touch with every other unit, and the whole is in direct communication with the chief ranger or other officer immediately responsible for the protection work on the area. In this manual, the principal means by which this inter-communication may be maintained in an unsettled timbered country are explained. Naturally, wherever adequate commercial telephone or telegraph services exist they will be employed, but these are of little importance in forest protection in Canada because settlement in timbered regions is extremely meagre.

Being intended for non-technical readers, it has been necessary in many instances to elaborate points that might otherwise have been passed over very briefly. For the same reason a certain amount of repetition has been thought desirable. The aim has been to bring together in one publication not only the details of telephone construction and operation practice as exemplified on the Dominion forest reserves, but also all available information on various communication methods that have proved to be useful in connection with forest protection activities. It is believed that only one subject of importance has been given very inadequate treatment and that is the question of pole preservation. This, it is planned to treat in a supplementary publication when certain investigations now being conducted are completed.

## PART I

# COMMUNICATION IN SPECIALIZED FOREST PROTECTION

## CHAPTER I

### SPECIALIZED FOREST PROTECTION

#### Section 1—Specialization Defined

As applied to forest protection, specialization involves two primary modifications of old style methods. These are, on the one hand, an extensive centralization of executive authority in the hands of certain field officers who are responsible for the protection of certain clearly defined forest tracts and, on the other hand, a classification of the duties of the field staff into certain well-defined functions and the assignment of special men to the performance of these special functions. This is best understood, perhaps, by comparing the actual organization of the old style forest protection staff with the modern specialized staff. In the more primitive of the former the staff consists of a number of district chiefs or inspectors each of whom is responsible for the general supervision of the patrol staff in a certain area. These inspectors are most likely permanent employees. Under each is a number of patrolmen or rangers, assigned either singly or in pairs, to a certain subdivision of the inspector's district, called as a rule a "beat." Each of these rangers is responsible for his own beat only and within that area he performs all the functions of the fire prevention staff. The district chief or inspector is required to keep moving from beat to beat principally for the purpose of ensuring that the rangers are in the areas assigned to them and are performing their duties. In addition, he, being a permanent employee and presumably more skilled in those duties than the temporary staff, can assist the latter by advice and instruction. This extremely simple form of organization has, however, only one point in its favour which is that it can be employed where the field staff is wholly untrained or unskilled in modern protection methods while no other form can be so employed. It is, therefore, particularly adapted to regions where the subordinate protection staff consists of extremely low-priced labour, as in India where natives are largely employed for this work. Where our own standards of wages prevail, such a system to be effective must be tremendously expensive. This is as inevitable in forest protection as it is in other forms of organized human activity such as manufacturing, transportation, or military affairs, from all of which in the modern world this system has long since disappeared.

Contrasted with this method of protection are the various more or less elaborated systems of specialization that have been developed by the leaders in forest protection. These developments differ in no material respect from those that have taken place in other large-scale activity but, owing to the nature of the work, they have followed more closely the methods of organization employed in military operations rather than those of most industrial activities. The most striking characteristic of a specialized staff is that instead of being a constantly moving patrol, each man confined to a limited area within which he performs all functions, it becomes very largely a stationary staff, each member of which performs only one function but may extend his activities over a large number of the old-time beats. Thus, instead of each man being individually responsible for detecting fires, certain men are specially assigned to this work and are located permanently on prominent lookout peaks or towers; instead of each man being responsible for putting out such fires as occur, special men, selected, equipped,

and located with this one end in view are placed at strategic points and are despatched only to such fires as are discovered by the lookout men; instead of each man getting in his own supplies for himself or a fire-fighting crew, a special man operating over a large area with suitable equipment and assistants takes care of all the supplies and transportation. In short, to establish a specialized forest protection staff means nothing more or less than the extension of division of labour on the modern basis of function to the work of protecting forests from fire.

### Section 2—Communication Defined

When we speak of communication in connection with forest protection we may have in mind one or the other of two rather distinct concepts. On the one hand, communication refers to the conveyance of materials or of men from one place to another. In this sense communication becomes a problem of transportation and lines of communication become roads, railways, trails, etc. With this type of communication, although it is of vast importance in forest protection, this manual is not concerned.

Communication in the other sense means the conveyance of information from one place to another. Obviously this does not necessarily involve any transfer of material substance, and lines of communication become telephone or telegraph wires, wireless installations, or signals of an almost endless variety. In this sense, communication is one of the prime essentials in specialized forest protection. Without well-developed means of transmitting information rapidly between all the numerous elements of a specialized force it is wholly impracticable to employ the distinctive features of specialized organization, and entire responsibility for all lines of work must necessarily be left in the hands of the patrolman, the least trained, and most poorly paid and equipped man in the whole force. This is obviously inevitable, however, in the absence of lines of rapid communication. At the same time it must be kept in mind that forest telephones and other modern devices for securing intercommunication do not of themselves produce specialization in a forest protection staff, but are merely a necessary mechanical device through the use of which functional organization and centralized control are rendered feasible.

### Section 3—Present Protection Methods

It is well recognized in Canada that forests if they are to be kept from burning up must have some kind of systematic protection during that portion of the year generally referred to as the "fire season." The extent of protection attempted largely depends upon the enlightenment of the owner of the timber, the value placed upon it and the fire danger or risk. This last is an extremely complex element made up of several factors which vary with the season, the character of the forest, the local causes of fire, and other local conditions which tend to favour or to obstruct the protection work. It is equally well recognized in the forested regions of Canada that the only kind of protection that has even a remote chance of success is patrol by a force of specially employed fire rangers. The patrol of timber-lands has been a feature of fire protection in certain parts of Canada for more than thirty years. In other parts it is only of recent origin, while very large areas in all parts of the country, bearing a young growth whose value and vital national importance are unrealized, are as yet wholly unprotected. A careful study of most of these patrol forces, however, reveals the fact that they are organized and operated on extremely individualistic lines. Some of the very largest operate almost without a directive staff and in no case has there as yet been developed a staff capable of making a close scientific study of this problem of fire protection, resolving it into its elements and building up on a basis of known facts a business-like organization and mode of procedure. In almost every case a

forest protection force in Canada consists simply of an indefinite number of more or less qualified men hired each year for the fire season only, and sent into the woods with only the most meagre instructions. In general they are told to prevent or to detect and suppress, so far as possible, forest fires in a specified district. Between rangers even in adjoining districts there is little or no relationship. There is practically no differentiation of duties and no guidance or supervision except a very occasional visit of inspection, primarily to determine that they are actually present in their district and are not employed at some other work. Even this is successful only to a very limited extent because of the inherent difficulties of maintaining close personal supervision over a force which of necessity is widely scattered over a vast area of undeveloped country.

The total annual expenditure for forest protection by all agencies in Canada is probably not less than \$1,500,000. Single agencies spend as much as \$350,000 per annum and employ 800 to 1,000 men annually. The value of the resource protected is of immense importance to the nation since fully 65 per cent of the country is capable of producing no other form of useful commodity. This resource is the raw material for the second largest industry of Canada. From this may be gained some idea of the relative importance of a scientific study of the business of protecting forests from fire.

#### Section 4—Analogy to Military Operations

It requires but little knowledge of the operations involved in forest protection under conditions existing in Canada to appreciate the striking resemblances which exist between this work and military operations on a large scale. It is noted at once that there exist the same problems of transportation, of commissary and supply, of scouting and reconnaissance, of intercommunication, of camp management, and the handling of men on the fire-line. Also there are frequently involved problems in field engineering, and in animal management. Further, it is readily possible to divide the actual process of placing a forest fire under control by frontal attack, flanking trenches, or back-fires into two main sets of operations, namely tactical and strategical. The present is perhaps an opportune time to point out the vital importance of organization and discipline, of special training for individual units, of perfect equipment, and of a skilled and scientific directive staff in military operations. Months, even years, are spent in training men for the least responsible of military positions and we know that an army without this highly perfected organization and equipment, no matter how individually excellent, is a pitiable thing before a modern military machine. It is little realized, however, that forest protection, which in all its essential operations bears such a striking resemblance to military operations, is susceptible of just as intensive study and development and that an unspecialized fire-ranger staff is, in its own sphere, just as pitiable an object when compared to a highly specialized staff as is an untrained ill-equipped army when compared to our modern troops.

As is well known, the extent and perfection of control maintained in modern military operations is largely the result on the one hand of the perfection of functional control secured through the General Staff and on the other of two elements of mechanical equipment, the gasolene engine as applied to transportation, and the telephone and telegraph as employed in intercommunication. It is one of the aims of this manual to indicate how these same highly developed means of intercommunication may be applied at small expense to the operation of directing forest protection forces.

#### Section 5—Functions of a Forest Protection Force

A careful analysis of the operations involved in the protection of forests from fire reveals the fact that a fire-control force exercises four principal functions. These may be called Prevention, Detection, Suppression, and Supervision. In an unspecial-

ized staff each member of the staff exercises all four functions. Naturally there is no organized staff so completely unspecialized that there is absolutely no differentiation of functions performed by different members, but nearly all of the forest protection forces of Canada are so little specialized that the overwhelming majority of the staff actually does have all these functions to perform. As in other industries so in forest protection, non-specialization means independence of action and lack of close co-operation. Thus we find that practically all fire rangers employed in Canadian forests are independent units, each supreme in his own district, performing individually all functions of fire control, and neither assisting nor receiving assistance from any other unit.

Where specialization has been adopted, however, the whole organization is radically different. Specialization is the basis of modern industry, and the gain in efficiency that resulted from the industrial revolution is no more striking than is the improvement that results from the adoption of similar specialization in forest protection. Obviously, no other result could reasonably be anticipated.

Specialization in forest protection is secured by employing separate units to perform each of the distinct functions revealed by the analysis of the operations of forest protection. It is neither possible, nor necessary, to differentiate functions absolutely in all cases, but instead of each member of the control force performing all functions each is given one as a primary function and exercises the others only to a very minor degree, if at all.

### Section 6—Prevention of Forest Fires

The function of Prevention, as the name would indicate, includes all those activities whose aim is to ensure that fires do not start in the forest. Statistics of the causes of forest fires, upon which all prevention plans must be based, show that for the eastern part of the country human agencies are responsible for at least 95 per cent of forest fires, while in the West about 80 per cent are thus caused. This difference is due to the lightning-caused fires which are relatively more numerous in the mountainous regions of the West. Fires due to human causes may be considered almost wholly preventable, and a forest protection staff must be prepared to make an exhaustive study of the causes of the fires with which it has to deal and to apply the necessary remedies. Prevention of forest fires involves a whole host of considerations mostly beyond the range of this discussion and even in actual application largely beyond the influence of the direct control forces in the woods. Certain preventive measures, however, belong primarily to the woods staff. Such, for instance, are advice and warning to forest travellers and tourists. This is of very great importance in many forested regions of Canada. A specialized forest protection force will have certain of its members specifically assigned to this duty wherever the directive staff determines, as a result of a careful study of fire records, that such preventive measures are needed. In maintaining this observation of tourists and other travellers a well-developed system of communication by which the patrol force is kept constantly informed of the entrance of parties into the forest and of their movements while there is of immense value. By means of it every person in the force is enabled to contribute indirectly to the prevention work and to assume this as a secondary function without in any way interfering with whatever happens to be his primary function.

Similarly, the supervision of "clearing" fires employed by settlers, an extremely frequent cause of disastrous forest fires, is preventive in nature, and many other activities of this kind must be provided for, according to local conditions. In all cases, however, it is necessary to emphasize that the fundamental basis for scientific and effective prevention work is an accurate knowledge of fire causes in any given region. This is best secured by rigid investigation of all fires that occur and the accumulation of statistics of causes over a period of years.



**Section 7—Detection of Forest Fires**

The method of performing the function of Detection has to some degree become a distinctive characteristic of a specialized staff. In the usual type of organization with little or no internal co-operation or interdependence of units, each ranger must depend upon himself alone to detect and locate all fires in his district. To accomplish this he adopts various methods according to the nature of the country and forest, the causes of fires, and his own energy, experience, and ingenuity. To some extent he relies upon reports received from various volunteer sources, supplementing this with patrol of routes of travel, and, if the region is favourable, with observations from commanding peaks, ridges, or even unusually tall trees. If he sights a smoke from a distance he can determine its location only by his knowledge of the country, aided by a map if he has one and knows how to use it. In most cases his determination is likely to be only a mere approximation and much time is lost in searching for the fire and making the exact location. This done, he must then undertake its suppres-



Fig. 1 Lookout station on a Dominion forest reserve in British Columbia

sion either alone or with such assistance, often inadequate, as he is able to summon to his aid. During the Suppression period, the protection of his district will most likely be left entirely to chance. The fatal weakness of this system is the slowness and uncertainty with which it operates. One of the most efficient fire-preventive organizations in the world has as its motto "Minutes Count" and nowhere in the course of a fire do they count more disastrously than in the first few hours. Practically all forest fires start as mere sparks. A neglected or half-extinguished campfire, a carelessly dropped match, the spark from a pipe or an engine, or some other similar insignificant source gives rise to the great bulk of disastrous fires. At the start and for some little time afterward, according to the weather, the season, and other local conditions, all such fires are easily within the power of one man to extinguish. But as they increase in size they increase even more rapidly in intensity. What was at first only a spark soon becomes a conflagration which only a very large crew of men can make headway against. The lesson, therefore, that every ranger

has learned is that the way to prevent large fires is to extinguish them when they are small—an obvious lesson—the accomplishment of which task is the primary purpose of specialization in forest protection.

There are in general but two ways to ensure that all fires will be extinguished in their incipiency. The one is to put in an overwhelming force and depend upon weight of numbers and extremely small districts to ensure success. The possibilities of this system are soon reached, owing to the prohibitive expense. The other system is to adopt specialization, to use fewer but more highly trained men, to co-ordinate their activities by organization and discipline and to assist them with every form of

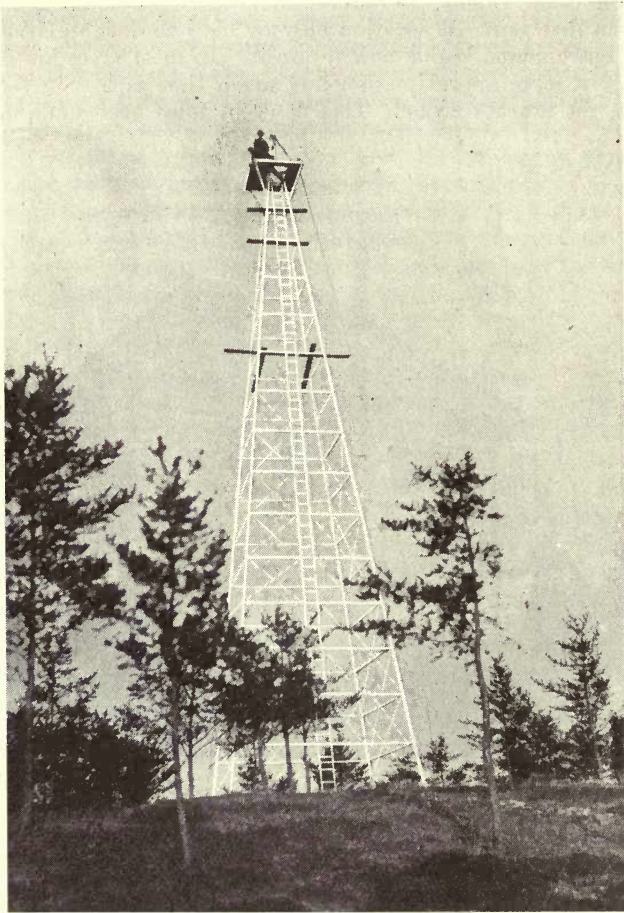

Fig. 2 Steel lookout tower on a Dominion forest reserve in Saskatchewan

mechanical appliance that will multiply their individual effectiveness. Among these appliances modern means of intercommunication are of basic importance, and in no respect is this more evident than in specialized means of Detection.

The function of Detection in a specialized staff is performed by units entirely distinct from the rest of the force. The nature of their duties is such that they can rarely perform any other duties even as a secondary function, and only in a very imperfect way can other units perform the function of Detection on a secondary basis. These units, charged specifically with the duty of detecting and locating fires, are known as "lookout men" and hundreds of them are employed in specialized forest

protection forces in the United States. They are a most picturesque unit, performing a little-known but valuable service under most unusual and often trying conditions.

For the most part lookout stations are established on the tops of prominent mountain peaks; mount Hood in the Cascades, mount Fairview in the Rockies, even the active volcano, Lassen peak, in northern California, and scores of other mountains throughout the Western States are used for lookout purposes. Several have also been established in British Columbia by both the Dominion and provincial forest services. In the Eastern States, notably in New England, a very extensive development of the lookout system has taken place. Practically the entire timbered area of these states, and large parts of many others as far west as Minnesota, are watched by permanent lookout men throughout the fire season. The location and character of the lookout stations is determined by the nature of the topography. If suitable sharp-topped peaks are not available towers must be erected. Lookout towers as high as 150 ft. have been built but ordinarily the standard steel towers which run from 30 to 80 ft. high are satisfactory.

Satisfactory lookout service in a specialized organization demands the continuous presence of the lookout man at his station throughout the daylight hours seven days in the week. This can be accomplished only by making the lookout station and dwelling-house one and the same. Accordingly a type of building has been especially designed for this work which is so arranged that no matter where the lookout may be while in the station he can always have a clear and unobstructed view of the entire area for which he is responsible. His duty, therefore, is easily defined. It is to remain at his station continuously throughout the day and maintain a constant watch over the area within his range of vision, noting all indications of fire, determining their location and reporting immediately to the proper unit of the control force. For the purpose of aiding him to fulfil his function he is provided with certain mechanical devices. These include tinted glasses to protect his eyes and aid him to distinguish faint smoke at long range, field-glasses with which to examine suspicious-looking smudges, a special form of lookout map correctly oriented, a fire locator (or alidade) for determining the bearing of a smoke, and finally a telephone or other means of communication by which he may report without delay. Rapid means of communication are fundamental to successful lookout service. For this purpose the forest telephone is universally preferred, but other means are sometimes used for reasons of expediency and are nearly always maintained in order to guard against temporary isolation of the station should the telephone line be broken.

Wherever a region is fully covered by lookout stations, the precise location of a fire within a distance of a fraction of a mile may be quickly secured by the simple process of intersecting from two or more stations. Where the fire is visible from only one station, other methods of location, slightly less exact, have been devised. Many difficulties in the establishment and maintenance of dwellings on the high peaks of the western mountains have been encountered and many ingenious devices resorted to in overcoming them which it is beyond the scope of this manual to discuss. Also, it is impossible to discuss the human factor in lookout service which is in itself an element of much importance.

### Section 8—Suppression of Forest Fires

A fire having been discovered and reported by the lookout man, the third element of the specialized staff is brought into action. This is the unit whose main function is Suppression. The title "smoke chaser" applied to this unit adequately indicates the nature of the service. The "smoke chaser" corresponds to the fireman of a city fire brigade. His duty is to remain within call of his telephone bell or other communicating apparatus and upon being advised of the location of a fire to proceed to it by the shortest route in the least possible time and to extinguish it. Here,

again, minutes count and every possible measure is taken to see that none are lost. If he travels on foot, his pack is ready to be instantly shouldered. After careful study and experiment a "smoke chaser's" pack, containing all essentials for three days and the tools needed for fighting a fire, has been devised to weigh only 21 pounds. If he can use a horse, it stands ready saddled and bridled; if he travels by power boat, it floats at his dock fully equipped. His only duty is to leave instantly, get to the fire in the least possible time, and do everything in his power to put it under control.

### Section 9—Supervision of Protection Forces

The "smoke chaser," however, is only the first or skirmish line of defence. Back of him stands the whole organized control force, the entire man-power of the community where this system has been most highly developed. This brings up the fourth function, that of Supervision. For the successful operation of a specialized protective force it is essential that the function of Supervision be performed by a permanent staff. In order to provide year-long employment economically this staff must necessarily be incorporated in the organization which is concerned with the woods operations. Private owners can incorporate it in their logging crews; governments, in the scaling or inspection staff. This is a particularly easy problem in Canada where logging is confined almost exclusively to the winter season and fire-ranging almost wholly to the season when logging ceases.

Keeping in mind the military analogy already alluded to, it will be evident that the supervising staff is nothing more or less than a skeleton organization composed wholly of officers, which organization can be rounded into a complete defensive unit by calling upon a large body of assistants of various degrees of training, according to the necessities of the season. In a region where anything in the nature of permanent settlement is found, this training may, indeed, be carried to considerable lengths and the efficiency of the force greatly enhanced.

It will be realized, however, in studying the details of forest protection work that it divides rather distinctly into two general classes. There is on the one hand the more strictly administrative duties which fall to the various supervising officers. These include the day-by-day supervision of the work of prevention and detection forces; the inspection of field conditions; study of fire conditions and labour supply; preparation and revision of mobilization schemes; the supply of provisions to field forces; direction of construction on improvement projects and various other activities not concerned with the actual process of fighting fires, but either preventive in character or in the nature of preparation for fighting fires that are anticipated.

On the other hand there is the actual forest fire-fighting, mostly on a small scale in a smoothly running organization but sometimes on a very large scale and with crews of considerable size. This, too, will as a rule be under the direction of the same supervisory officer, although in some cases the actual executive work on the fire-line is placed in the hands of a fire-line foreman while the supervisory officers devote their attention to co-ordinating the various auxiliary services and determining the general strategy of the fire-control operations. Here is seen a distinct development of staff and line functions as will be hereinafter explained.

### Section 10—Duties of Supervising Officers

It will be readily apparent that the duties and responsibilities of the supervisory officer in a specialized staff are much more extensive and call for a far more careful training than those of any grade of employee in a non-specialized force, or even in the other units of his own organization. He must be more carefully selected, more highly trained, and, naturally, better paid. His duties in connection with fire prevention are as follows:—

## 1—DIRECTOR OF PERMANENT FORCES

The maintenance of supervisory control over the entire prevention, detection, and suppression staff regularly employed in his district is of first importance to the supervisory officer.

To do this it is essential that he be able to maintain communication with all units of this staff. This is accomplished by the proper planning of the permanent lines of communication within the district and the skilful use of the portable and emergency equipment described in this manual.

## 2—MOBILIZATION OF SUPPRESSION FORCES

The supervising officer must organize and direct the mobilization of all the forces needed to form the main and supporting lines of defence in fire suppression. While the aim of specialized forest protection is always to handle all fires in the incipient stage this ideal cannot always be maintained, and through delays in detection or reporting, faulty location or other failures, some fires will prove too formidable for the "smoke chaser" alone. There are few forest regions even in the more remote parts of Canada's commercial timber-belt where there is not some form of local settlement. Where agricultural settlers are not found there are still logging camps, miners, construction crews, or perhaps surveyors, tourists, summer residents, hunters, etc. The communication system must be planned to put the supervising officer in direct touch with all these sources of labour and he must organize this labour so that in case of emergency it may be called upon for assistance with a reasonable certainty of an immediate and effective response. This has been accomplished in several ways but probably the most successful has been through the organization of volunteer fire companies, organized with all the necessary officers and bound by agreement to report on call at designated points. Many factors and local conditions necessarily cause wide variations in the possibilities of developing these forces for use in fire emergencies.

In the more highly perfected organizations it is possible to distinguish three lines of defence or classes of forces behind the "smoke chaser." These may be called:—

(a) *Main line forces*, which are as a rule made up of all the available employees of the timber-owner;

(b) *Supports*, which consist of local residents usually scattered through or on the immediate borders of the forest who are under definite contract to perform certain specified emergency fire duties; and

(c) *The Reserves*, which may consist of organized volunteer fire companies as outlined above or may be simply an available labour supply at some adjacent centre where arrangements for securing men have been made through labour agencies or other means.

Whatever is the form and composition of the Supports and Reserves, the mobilization, equipment, and transportation of these forces to the fire-line must be handled by the supervisory officer and his staff. Fire plans, which are an essential feature of specialized fire protection, detail the means for accomplishing this concentration, but the expeditious carrying out of the features of such a plan is largely dependent upon the system of communication.

## 3—MAINTENANCE AND DIRECTION OF SUPPRESSION FORCES

Finally, the supervisory officer must provide for the maintenance of his forces on the fire-line and the direction of the work of suppression by these forces. In this, his problems differ from that of the military officer in no material aspect except the merely rudimentary development of his medical service and the absence from his transportation columns of anything corresponding to the enormous quantity of ammunition required by modern troops. A complete discussion of this phase of the function of supervision

might constitute the subject matter of a manual of forest protection and is beyond the scope of a manual on communication alone, but the main divisions of it may be very briefly considered. In doing so, however, it is necessary to recollect that although the object of all fire-protection forces is principally to prevent fires, nevertheless the supreme test will come in the actual handling of a dangerous forest fire and all organization must be based upon preparation for this contingency. This, of necessity, involves a somewhat elaborate organization which must be provided though it may never in practice be utilized for the purpose intended. From this it does not necessarily follow that a staff is held idle merely awaiting emergencies that no effort is spared to avoid. On the contrary, the skill of the organizer is shown by the way the necessary staff is secured for emergency work without continuous maintenance. This force as already indicated is divided into line and staff according to the nature of its duties.

### Section 11—Duties of Suppression Staff Officers

These are five in number and give rise to five separate departments, but it is seldom, even in a very dangerous region, that all are separately organized.

#### 1—TRANSPORT

The transportation problem becomes important only when relatively large fires must be fought at a considerable distance from a base of supplies. Its difficulties arise more from the poor quality of the lines of communication over which transportation takes place than from any other factor. Crews seldom exceed 100 men though more than 1,000 have at times been engaged in one locality. Distances are sometimes considerable, frequently 25 miles beyond the railways, sometimes more than 100 miles. Wagons, boats, or pack-horses are the usual equipment employed. Sometimes motor-cars may be used but on the other hand it is sometimes necessary to pack supplies on men's backs. When, as is nearly always the case in the western forests, pack-horses are the only feasible means of transport, the maintenance of a hundred men on a fire-line is quite as difficult a transport problem as is the maintenance of 2,000 or 3,000 men in a country where modern motor-trucks may be employed.

The transport service in a specialized force is seldom under the direct charge of the supervisory officer having immediate charge of the smallest fire-protection district or unit of area. As a rule ten or more such districts are combined under an officer of higher rank and the transport service for the entire group is handled from a central headquarters. Where necessary a chief transport officer, generally called the "packmaster," is employed for this purpose.

A very important element of transportation is the condition of the lines of communication, such as roads and trails. It must be the constant aim of a forest-protection force to improve these lines at every possible opportunity. In the accomplishment of this an intercommunicating system is of the highest importance. Its value arises from the fact that in scarcely any forest region is the fire season continuous, but owing to rains there are periods of greater or less length when no fire is likely to occur. The efficient organization will plan to use the fire-protection staff during such periods for the extension or improvement of lines of communication. This is accomplished by preparing in advance careful plans for necessary improvements to roads, trails, or other permanent works, distributing the work as much as possible to all districts. Immediately on the occurrence of a heavy rain, the fire-control force is swung on to improvement work through the medium of the intercommunication system and is kept employed on this work at the discretion of the supervising officer until conditions again require a return to fire-control duties. The

amount of work that may be accomplished in this way depends on the seasonal conditions but it rarely happens that a fairly considerable total does not result from careful preliminary preparation and skilful use of opportunity and of the means of communication available.

## 2—COMMISSARY

The bulk of the material handled by the transport service to fire-fighting crews is food. This is supplied in the most successfully organized forest districts through a central depot which distributes to a group of fire-control districts, generally the same group as is handled by a single transport officer.

The officer in charge of the commissary is called the "quartermaster" and, in fact, very often combines the duties of quartermaster with those of packmaster. He arranges for the delivery of the necessary food, tools, and miscellaneous camp supplies, such as tobacco, socks, etc., from the main supply points in the nearest towns to one or more base stations from which they are distributed to the fire-fighting crews as required. The cooks at the various camps make requisition upon him for supplies either directly by telephone or other line of rapid communication, or indirectly by message to the nearest telephone station. The extreme uncertainty of the extent or duration of this class of work constitutes the principal element of difficulty for the quartermaster, and this he is enabled to minimize by being in constant direct communication with each camp.

## 3—FINANCE AND ACCOUNTING

The payment of fire-fighters must be handled promptly, especially where large crews of a floating class of labour are involved. Also, an efficient organization will want to maintain an accurate record of its expenditure and an adequate cost-accounting system. This is generally handled by a paymaster who disburses for a group of fire-control districts, often including two or more groups of the size handled by a single quartermaster or packmaster. The intercommunicating system expedites the work of the paymaster by enabling him to get advance information in regard to the men coming out and the amount of disbursement he must be prepared to make each day. This is often of great importance in regions where banking facilities are limited. On the fire-line he is represented by the timekeeper who, however, generally has other duties to perform as well.

## 4—INTERCOMMUNICATION AND RECONNAISSANCE

As has already been indicated it is of vital importance to the efficient operation of each of the several departments of the fire-control staff that constant communication be maintained between the fire-fighting crew and the various headquarters in the rear of the fire-line.

It is also of much importance on a large fire that the officer in charge be kept constantly informed of the progress of the fire in all its parts and of the success or failure of the various control measures undertaken by the forces combating it. This, of course, assumes that a relatively large fire is being subdued. Small fires may be readily observed by the officer in charge and no special organization for securing information is needed. On large fires, however, it is frequently found desirable to employ a scout or intelligence officer. The duty of this member of the force is to keep the chief of the fire-fighting force informed of all important features of the work of fire control and of the progress of the fire itself where not yet under control. He is also, as a rule, charged with establishing and maintaining communication with the headquarters in the rear. Now, it rarely happens that a fire camp is located on a permanent telephone line. If, therefore, it is considered necessary that the camp be equipped for direct communication it becomes the duty of this officer to provide telephone connection or

establish communication by some other direct means. The methods by which this may be done are explained in this manual in Chapter X of Part II and in Part III. It is desirable here only to indicate the organization by which it is effected. Naturally, such communication will be required only in exceptional cases. A camp that will be occupied for only a few days at the most and that would need to send only a very few messages would handle them by messenger. But where a large camp may be occupied for a period of weeks, perhaps, and is only one of several engaged in the control of a single large fire, then it may be extremely important to establish direct connection. It is the same problem that faces the military officer who must decide whether to send an order by messenger or have it transmitted by signal. The circumstances in each case and knowledge of the possibilities of all means available must be the guide in the action taken.

#### 5—FIRE SUPPRESSION STRATEGY

The strategy of fire-fighting as distinct from tactics has the same significance as in military operations, that is, it comprises all those broader elements of the problem such as existing conditions of fire, topography, season, forest, forces available, and other factors which taken together determine in a broad way the general method of attack. Unfortunately there is not available in fire-fighting records any body of detailed reports of fire-fighting operations with the reasons therefor and the results attained, such as exist in military history, and lacking this essential data fire-fighting strategy still remains in a condition of very rudimentary development as a practical art. In actual practice it is necessary to rely entirely upon the individual capacity of some member of the force who has himself only his own individual experience to depend upon. Non-specialized forces assume this knowledge of all their members. Specialized forces undertake to bring to bear on this important line of work a more extensive experience by making available for study by the permanent staff such detailed reports of fire-fighting strategical operations as can be secured and by relieving some of the staff officers of most of the usual details of forest protection work so that they may give special attention to this important phase.

### Section 12—Duties of Suppression Line Officers

#### 1—CAMP MANAGEMENT

Unlike military camps, fire camps are extremely simple. It is very seldom that such camps are large enough or remain in one place long enough to require special sanitary precautions or highly specialized organization. Provision for safety in location is necessary but usually is easily secured. The same is true of provision for medical service. Injuries, sometimes fatal, are not uncommon in fighting fires and yet, on the whole, they are not sufficiently numerous to require any special organization. There is, therefore, in a specialized fire-protection staff nothing that corresponds to the medical corps or sanitary corps of an army. All responsibilities of this nature as a rule fall upon one of the line officers, such as the camp foreman. The greatest advance has probably been made by those organizations which maintain at their base supply stations a number of special fire camp first-aid kits, which are distributed by the quartermaster as needed, and handled by the timekeeper or the camp foreman in the field.

#### 2—FIRE SUPPRESSION TACTICS

The tactics of fire-fighting include all those specific measures of control that are employed in the immediate vicinity of the fire. As a specific illustration, a decision to divide the crew and begin the attack on the fire on both flanks at once rather than to endeavour to combat the head is a strategical one, but a decision as to whether to cut a trench near the edge of the fire or to use a trail existing at some distance from the



edge or to make no guard-line at all but try to beat out the fire or to extinguish it with water, is a tactical one. Fire-fighting tactics have advanced much further in organized development than has strategy. A considerable number of methods are known and much has been done toward improving these methods. Particularly is this the case in methods for using water in fighting forest fires. Theoretically water is the ideal material to use for fire extinguishment but the practical difficulties of getting the material to the point of use are very great in all but a few very limited regions. As might be anticipated, it is only those highly perfected organizations which have solved the problems of preparedness and strategy that are able to advance with real success beyond the simple fire-fighting tactics to the employment of more elaborate methods involving the use of water, particularly the employment of gasoline pumps.

### Section 13—Value of Communication System in Field Operation

The value of a highly developed system of communication lies in making possible the rapid concentration of adequate control forces on the fire-line and in their successful maintenance. It has little direct bearing on the actual conduct of the fight. Indeed, an unspecialized force with no rapid means of communication may use just as efficient tactics as the most highly specialized force with the most improved system of intercommunication. Where it will fail, however, will be in the early discovery and in the rapid concentration of adequate forces in such fires as occur and in the ability to handle and maintain large forces in regions of difficult accessibility. The result is seen in comparing the records of specialized with non-specialized forces. Wherever conditions are at all comparable, a specialized staff will secure protection at a mere fraction of the cost of equal protection by an untrained non-specialized staff. Moreover, the specialized force will be able to secure adjustment of expenditure according to the character of the season from year to year, or even from period to period during any one season, which an unspecialized force cannot do with any real success. Finally, the specialized force will weather the periodical unfavourable seasons with success, both because it expands automatically according to the danger and because it strikes quickly and places fires under control without delay. It cannot be taken by surprise but detects and locates fires with certainty and precision while they are still in an easily controllable stage. Its record will show few or no large fires in a dangerous season and a low average of acreage per fire, while the record of the non-specialized force in a dangerous season will always show a break-down more or less complete and a high percentage of fires that get beyond all control and burn themselves out or until extinguished by rain. These periodic break-downs are of much greater importance in judging the efficiency of fire-protective organizations than is generally admitted, since it not infrequently happens that the destruction that occurs in a single disastrous season more than offsets the protection afforded during a very long series of favourable years. On the whole, in most timbered regions where advancing settlement, railways, lumbering operations, and various other developments have radically changed the forest fire situation for the worse, no organization for forest protection can be considered efficient unless it has made adequate provision for automatically expanding during exceptionally dangerous seasons, so that it can at all times keep the situation well in hand. *The real test of success is not control of fires during normal seasons but control during the periodic abnormal season without the necessity for keeping up at all times a large and expensive organization that serves no other useful purpose.*

## CHAPTER II

### METHODS OF CONVEYING INFORMATION TO A DISTANCE

#### Section 14—Variety of Methods Available

Perhaps the oldest and simplest means by which information may be conveyed from one point to another is by messenger. The most modern and technically complex is the wireless telegraph and telephone. Between these two extremes lies the whole knowledge and experience of man in the solution of this problem. This has always been a problem of paramount importance to military forces so that we find in military literature the most complete and exact records of the various methods by which it has been solved. These methods are of the most varied character but may all be divided into two principal classes: the Visual Signals which are received through the sense of sight and the Audible Signals received through the sense of hearing. In order to show the possibilities for selecting methods adapted to particular circumstances, it is of interest to note briefly the characteristics of the more important types of signals and other means of conveying intelligence to a distance.

The use of carrier pigeons, so extensively employed in military and naval operations, has, so far as the author is aware, never been attempted in forest protection. There seems to be no reason, however, why carrier pigeons could not be very successfully employed in this work.

#### Section 15—Types of Visual Signals

##### 1—WIGWAG SIGNALS

This system consists in forming the symbols of the telegraphic code by moving various objects in certain ways with reference to some fixed object. A flag swung to the left or to the right, for instance, the person swinging it acting as the point of reference is a common method of sending wigwag signals. Torches, lanterns, or in fact any object visible at a distance may be similarly employed. Over great distances the beam of an electric searchlight thrown vertically can be used to send messages by wigwag.

##### 2—SEMAPHORE SIGNALS

By varying the positions of objects of the same shape with reference to a fixed object, it is possible to form symbols that represent the letters of the alphabet. Thus, the two arms may be so held with reference to the body and to each other as to form all the different symbols needed to send the full alphabet. To extend the range of visibility small flags are held in the hands. Special semaphore machines with movable arms of large size are also used. Within a limited range this system has many advantages, particularly that of speed.

##### 3—CODE SIGNALS

Without attempting to send alphabetical symbols it is possible to send pre-arranged messages by the use of objects of different colours or shapes or by a combination of both, using one or more of them to represent each code message. Flags of different colours and designs are most commonly employed for this purpose and the system is used for communication by ships at sea and for such purposes as displaying storm warnings or other weather signals. Of course, similar flags of distinctive colour or design may also be used to represent the letters of the alphabet and words spelled out in full.

##### 4—CHRONOSEMIC SIGNALS

In all the foregoing systems the time of display of the signal does not form an essential part of the method. Several systems are in use, however, in which time is

an important element. In one of these, the chronosemic method, the basis is the time interval that elapses between two displays of the same object. To form the letters of the alphabet by the International Morse Code it is only necessary to be able to make two symbols, a dot and a dash. This may be done by allowing a short time interval between two displays of a flag, for instance, to stand for a dot and a longer interval to stand for a dash. It is a method that is valuable, however, only when using for display something that cannot be easily controlled as to the length of time it remains visible. Such, for instance, are rockets or bombs of only one colour. The interval between displays of these devices may be easily controlled and varied but the duration of the display itself cannot be controlled. Smoke puffs or flashes from a hand mirror are somewhat similar but any visible object may be used if desired.

#### 5—FLASH SIGNALS

Instead of forming the dot and dash of the code letters by the time interval *between displays of an object*, it is readily possible to form them by the time interval *during which the object is visible*. This, of course, pre-supposes that the duration of visibility is entirely under control. Although a great many different objects may be used for this purpose, the actual application of the method is mostly made through the medium of sun flashes from mirrors, or flashes from different forms of signal lamps. The apparatus used being provided with suitable devices for controlling the duration of the flash, it becomes readily possible to form the code letters by making a short flash for a dot and a long flash for a dash. Other objects less frequently used are flags and disks.

#### 6—ELECTRO-TELEGRAPHIC SIGNALS

The ordinary telegraph may be easily equipped so as to furnish a written or printed message. This might, perhaps, be included under visual signals though this term is generally confined to non-electrical means of communication only. Similarly, the mirror galvanometer used in submarine electric telegraphy is also a form of visual signal.

#### 7—SHAPE AND COLOUR SIGNALS

In addition to the foregoing there is a numerous and important class of signals in which the operator depends upon using two or three objects of easily distinguishable shape, or two or three lights of different colours, to form by their arrangement all the letters of the telegraphic code. For the two-symbol codes, such as the International Morse Code, only two shapes or colours are required. Each represents an element of the code letters and by displaying them simultaneously in the proper relation to each other, or separately in the proper sequence, the entire alphabet may be readily formed. Thus, for day signals a ball may represent a dot, a cone may stand for a dash, and with combinations of these two shapes displayed together all the letters of the code may be formed. At night several methods are employed using coloured lights, rockets, coloured balls, or bombs, and coloured lanterns. One method, known as the Ardois lantern system, employs an ingenious arrangement of electric lanterns which can be operated by a special switchboard from a distance and at considerable speed. The range over which such signals may be seen, however, is comparatively short.

### Section 16—Types of Audible Signals

Audible signals are not of such a varied character as are the visual signals. They are of two main classes: non-electrical and electrical, and may be tabulated as follows:—

Non-electrical, (1) Detonations—revolver or rifle shots, dynamite explosions, (2) whistle or trumpet blasts, (3) bells.

Electrical, (1) Electric telegraph or telephone with wires, (2) electric telegraph or telephone without wires.

The range of non-electrical audible signals is extremely limited, unless detonations or whistles of immense power are employed. Further, they are of limited application because relatively slow. Nevertheless, such signals are very widely used for the purpose of conveying code messages where only a few very simple messages need to be employed. Such, for instance, is the employment of whistles and bells on boats, trains, and steam-logging operations, of detonating torpedoes on railways, and of whistle and trumpet blasts in the directing of military manœuvres.

Electrical means of communication are the most modern and most efficient of all the methods employed. Thus far, of the wireless methods, only the wireless telegraph has been brought to a high state of perfection. Of the methods of transmitting intelligence electrically over wires, three principal types may be recognized as follows:—

- (1) Transmission of the telegraphic code by the common type of telegraph key, relay, and sounder.
- (2) Transmission of the telegraphic code by the buzzer system, using a telephone receiver as the sound-receiving apparatus.
- (3) Transmission of the human voice by the telephone.

The first has maximum range and reliability of equipment but requires a rather high degree of electrical insulation in the connecting lines and special training of the operators. Where a high degree of accuracy in the message transmitted is required, it is the most rapid of the electrical methods of communication, exceeding in this respect even the telephone. On the other hand, it offers little or no chance for secrecy of messages sent.

The second has a limited range but certain advantages in operating over lines of poor electrical insulation. The apparatus is comparatively simple but special training is still a requisite for operation.

The third employs a more complicated apparatus but one whose mechanical development has reached a very high degree of perfection. It has the immense advantage of requiring no training for its successful operation and of being under certain conditions the most rapid of all means by which information may be transmitted. It requires a higher degree of electrical insulation than the second method and has not the range of the first, but has been shown to have sufficient range for all necessary purposes of forest protection. Further, it is the only practicable apparatus by means of which the sender and receiver of the message can communicate directly with each other without the interposition of a third party.

All the foregoing methods involve the use of wires connecting the points with which communication is desired. Only at points where actual physical connection to these wires can be made is it possible to send or receive messages by these systems. A considerable investment in construction and a continuous charge for maintenance is, therefore, involved in the use of any one of the systems. On the other hand, the apparatus required for making connection to the wires when strung and for establishing communication with stations is extremely simple and easily portable in all cases.

The wireless systems of communication, while offering many theoretical advantages, particularly through dispensing with the use of wires, have not, however, been developed to the point where they are to be considered as serious competitors of the present system of telephones with wires. Although improvements are constantly being made in this field of communication, the requirements of extreme portability are, as yet, met more effectively by the equipment at present in use. The development of the wireless telephone during the war has been such that its employment as a supplementary equipment must be given serious consideration. To a certain extent the use of the wireless telegraph as a temporary or as a supplementary equipment may also be advantageous, but the necessity of having trained operators is a serious disadvantage of this system. The ultimate development of the wireless telephone is of the utmost interest to all who are interested in forest protection as it promises to overcome, when perfected, nearly all of the obstacles at present met with in the establishment of cheap, reliable, and quick communication in forested regions.

## CHAPTER III

### ADAPTING COMMUNICATION METHODS TO SPECIALIZED FOREST PROTECTION

#### Section 17—Speed and Certainty in Communication Essential

The units that compose a specialized force have already been described. Practically all of these units must be equipped to communicate with each other in order to operate efficiently. Some of them are wholly useless without rapid and reliable means of communication at all times; on the other hand the more nearly perfect the system of intercommunication between *all* the various units can be made, the more efficient will be the protection under given conditions. Centralization of direction is only workable when the central directing intelligence is in constant touch with the many scattered units of the field force. How far centralization can be carried advantageously will perhaps be a matter for discussion, but there can be no question that any change from a method that reposes all responsibility in the lowest member of the staff must be accompanied by development of means for keeping the field units in constant direct communication with the supervising staff. Also, any specialization of function as, for instance, the employment of permanent lookout men to detect fires, necessarily involves the provision of means whereby these men can quickly and surely transmit to the suppression forces information with regard to fires located. This must not necessitate the lookout man leaving his station and, to be more efficient than the old style patrol method, it is essential that the lookout men transmit the news of all fires located in less time, in all cases, than the average time for detection and location required by the patrol. Speed and certainty in the method employed are, therefore, fundamental necessities.

#### Section 18—Method must be Adapted to Conditions of Use

It will be apparent from the discussion of the methods of transmitting intelligence that there is a very wide range in the capabilities of the many forms of signals employed and that a choice of type for a given use must be governed by the requirements of that use and the characteristics of the signalling methods themselves. The latter are of the most varied description. Some can be used only in daylight, others only in full sunlight, while many can be employed only at night. Atmospheric conditions have a considerable influence on the range of all types of non-electrical visual signals, on some audible signals, and also to a less extent on electrical systems. Possible ranges, with different methods under given conditions, vary from a few hundred yards up to hundreds of miles. Possible speed of transmission of given messages under given conditions likewise shows a wide range. Various degrees of skill and training in the operation of different systems are required and the ease with which skill is acquired varies. The apparatus required shows great diversity in cost, complexity, portability, ease of manipulation, and ability to stand rough usage. The variations in cost and difficulties of installation and maintenance are equally wide.

On the other hand, there is to be considered the requirements of the service demanded by a forest-protection staff. In order that this may be understood it is well to have clearly in mind the principal units of a specialized staff.

#### Section 19—Control Units Requiring Intercommunication Facilities

From the location, function, and methods of operation of these various units it is possible to arrive at a general idea of their requirements in the way of means of communication. The principal units involved are:—

1—PATROLMEN.—Moving units, mainly preventive in function. They are employed only where fires of human origin are likely to occur in considerable numbers, such as around new settlements where they issue brush-burning permits and supervise burning operations. Along railways patrolmen combine detection with suppression, and through examination of spark arresters, etc., help with preventive measures.

2—LOOKOUT MEN.—Stationary units, whose only function of importance is detection. They are located on commanding peaks or other elevated stations from which a great scope of country can be observed.

3—"SMOKE CHASERS".—Largely stationary units whose principal duty is suppression. They may be stationed with the lookout men or at points near the bulk of the timber to be guarded, if the lookout station is not itself in a readily accessible and central location.

4—DISTRICT RANGER.—The supervisory officer who directs the work of the preceding units within a definite area or forest district and also has administrative control of the main line of defence when larger fires must be controlled, and of the supports and reserves. His chief executive assistants are:—

(a) *Intelligence Officer or Scout*.—His duties are to secure information in regard to the behaviour of fires and the progress of control work;

(b) *Packmaster and Quartermaster*.—As a rule these services will be directed from a central headquarters having control over a large number of ranger districts, but in cases where the system of communication is not fully developed it is sometimes necessary to establish separate supply departments for each of the smaller districts;

(c) *Fire Bosses*.—In the more complete organizations each individual large fire is handled by a special fire boss under whom are the various camp foremen in charge of line crews. In many cases, however, the district ranger is himself the fire boss.

5—SUPERVISOR.—The officer having administrative control of a group of adjacent forest districts. His chief executive officers are the district rangers in charge of fire control and the following chiefs of special services:—

(a) *Paymaster*.—The disbursing officer;

(b) *Packmasters*.—One or more officers in charge of transportation;

(c) *Quartermasters*.—One or more officers in charge of commissary.

## Section 20—Communication Requirements of Control Units

The normal communication requirements of these units are as follows:—

Unit	Communicates with	Distance		Class of Message
		Common range of distance	Average distance	
Supervisor.....	District Ranger.....	Miles 0 to 100	Miles 25	Long, intricate.
	Packmaster (not at headquarters).....	25 to 100	40	Generally brief.
	Quartermaster (not at headquarters).....	25 to 100	40	Generally brief but occasionally long and very intricate.
District Ranger.....	Lookout Man.....	5 to 100	30	Sometimes long and very intricate but generally short and precise.
	Lookout Man.....	1 to 30	10	Same as above.
	"Smoke Chaser".....	1 to 30	10	Same as above.
	Patrolman.....	5 to 30	10	Generally long but relatively infrequent.
	Supervisor.....	1 to 100	25	Long, intricate.
	Supports.....	1 to 50	10	Long and intricate or short and concise according to perfection of organization and discipline.
	Reserves.....	1 to 50	25	Same as above.
	Camp Foreman.....	2 to 15	5	Very long and intricate
Lookout Man.....	Scout.....	2 to 20	10	Very long and intricate.
	Supervisor or District Ranger.....	1 to 100	30 or 40	Sometimes long and intricate but generally short and precise.
	"Smoke Chaser".....	0 to 20	10	Same as above.
"Smoke Chaser".....	District Ranger or Lookout Man.....	1 to 30	10	Generally short and precise.
Scout.....	Lookout Man.....	2 to 30	10	Short and precise only when long intricate messages are not feasible.
	Camp Foreman.....	0 to 5	2	Short and precise.
Quartermaster and Packmaster.	District Assistant on a fire	5 to 100	30	Often long and intricate.
Camp Foreman.....	Scout.....	0 to 5	2	Generally short but may be very long on occasion.
	Fire-line Crew.....	0 to 1	$\frac{1}{2}$	Short, precise or long and very detailed.
	District Ranger.....	2 to 15	5	Long and intricate.
Patrolman.....	District Ranger.....	5 to 30	10	Short and precise or long and very detailed.

An analysis of these requirements reveals the following facts:—

(1) Most of the messages which it is necessary to transmit are long and involved in character.

(2) The longer and more intricate messages generally have to be transmitted over great distances but in a relatively few cases over very short distances.

(3) Where relatively short distances are involved there are generally two classes of messages to be transmitted.

(4) The longer distances vary on an average from 10 to 40 miles, with 100 miles as a usual maximum..

(5) The shorter distances vary on an average from one-eighth of a mile to 5 miles, with 15 miles as a maximum.

### Section 21—Superiority of the Telephone Evident

A study of the kind of messages that must be sent, the men who send them, and the ranges over which the communication system must operate leads inevitably to the conclusion that only the telephone comes near enough to meeting all requirements to form the basis of the system. It is among the most rapid of the methods of communication and, therefore, well adapted to long intricate messages; it requires no skill to operate, will give more service at less cost, considering installation, operation, and maintenance, than any other system, operates efficiently within the range limits desired, may be connected with at any place along the wires with easily portable equipment and, as will be shown, may be quickly and cheaply extended within adequate limits to new locations for temporary use during emergencies.

Its advantage over the telegraph is largely in requiring no training to operate. Over wireless methods it has the same advantage while additional objections to wireless are the relative non-portability of the equipment for sending purposes, the complexity of the apparatus, and the limitations on the establishment of sufficient stations due to cost. The telephone, therefore, must form the basis of our entire system of intercommunication, and as a result of this decision equipment and methods of construction particularly adapted to forest-protection purposes have been specially developed and employed until there are now more than 30,000 miles of such lines in successful operation in the United States and nearly 2,000 miles in Canada.

### Section 22—Auxiliary Methods often Required

The wide acceptance of the telephone for this class of work, however, does not entirely obviate the necessity for giving some consideration to other methods of communication. Several important conditions must be recognized wherein the telephone alone does not fully meet all requirements. In this we find another parallel to military communication for, in spite of the perfection of telephonic communication by army signal services, several other means of conveying information have been carefully developed. In forest-protection work various other systems are of considerable value under the circumstances that will now be explained.

#### 1—COMMUNICATION IN ADVANCE OF TELEPHONE CONSTRUCTION

In equipping a large area of timber-land with telephonic communication it will nearly always be impracticable to install a complete system in a single season. In fact for reasons of expediency a considerable period of years may elapse before such a forest is fully equipped. There arises then an immediate need for some temporary system of communication which will bridge over the period during which the permanent system is in process of development. This is a consideration of very great importance in Canada where specialization in fire protection, with its accompanying construction



of intercommunication systems in the forests, is just beginning. This temporary equipment must be as inexpensive as possible, because it is merely temporary. It must be capable of transmitting messages over long distances. Simplicity and ready portability of equipment are desirable. It must be fairly easy to operate and be reasonably certain and reliable.

Among all the various signalling apparatus previously described the heliograph alone meets these requirements. A heliograph costs, complete, from thirty to sixty-five dollars, about the cost of a single mile of telephone line. Its range is much greater than the ordinary maximum distance required in forest work. It is remarkably simple in construction and the new forest-protection type is easily carried by a horse patrolman. Experience has shown that with a few days expert instruction intelligent rangers can acquire sufficient skill in its use to form the basis for attaining speed by individual practice by themselves. In speed it cannot be compared with electrical systems and it has the further disadvantage of operating only in full sunlight. The lack of speed may to some extent be compensated by adopting a code of pre-arranged messages, as will be later described, and the necessity for full sunlight is also to a certain degree compensated for by the fact that periods of dull weather are very likely to be periods of low fire-danger and, therefore, lessened need for communication. Heliograph stations must, of course, be visible from each other. This requirement is the most serious limitation on the use of this instrument, but not when used on lookout stations where it is most frequently employed.

## 2—SUPPLEMENTARY EMERGENCY EQUIPMENT ON LOOKOUTS

A further need for a means of communication other than the telephone is found in the equipment of permanent lookout stations even after they are connected with the telephone system. Lookout stations are absolutely dependent upon communication for the maintenance of their successful operation. No form of electrical communication dependent upon aerial wires is wholly safe against interruption, and such interruptions are particularly likely to occur during heavy storms and thunder-showers. This introduces a dangerous element of uncertainty, especially in the West where a great many forest fires are started by lightning, and the chances of the lookout being isolated by the very storm that is causing fires to spring up is a hazard that cannot be ignored. The most effective way to guard against this is to take a leaf from the book of military experience and provide auxiliary means of communication for use when the usual means fail. For this purpose the heliograph is again the most suitable apparatus and a permanent use for some of the temporary installations may thus be secured.

## 3—PATROLMEN

Still another use for supplementary means of communication arises with the patrolmen. As previously explained, these units are usually assigned to sections of known fire-risk, such as railways or other important routes of travel. Railway patrolmen are usually adequately equipped if provided with a portable telephone for connection to the lines paralleling the right of way, but patrol in a region remote from railway lines may be isolated from telephone connection. Such patrolmen should, if possible, be enabled to maintain communication, but the messages they need to send are likely to be of considerable length. It is, therefore, necessary with each route to weigh the time required to signal the usual message against the average time needed to reach the nearest telephone line, and on this comparison make a decision in regard to the equipment to be furnished. In a region covered by lookout stations it should be quite easy for such patrolmen to establish communication with a portable heliograph in case the distance to the telephone line is too great.

## 4—SCOUTS

A still further use for auxiliary signals arises in the case of the scouting service on forest fires. It is particularly necessary that men employed on this work be well acquainted with various means of maintaining communication so that they may be equal to any emergency. While, normally, communication with large camps will be established with emergency telephone equipment, many cases will arise, especially while the telephone system is in course of development, where this will be impracticable. Two uses for some means of signalling are likely to arise under these circumstances:—

(a) When it is desired to open communication between the camp and the headquarters somewhere in the rear. The distance will necessarily be great, otherwise the telephone would likely be employed. For this use only the heliograph is suitable;

(b) When it is desired to communicate from the heliograph station to the camp or camps, or from one scout to another, or to a ranger on the fire-line, or across some impassable barrier. The distance is likely to be short and the message concise. The equipment must be of the simplest possible character. These requirements are most readily met by flag signals. Flags, as will be hereinafter explained, may be used to convey messages either by the wigwag or the semaphore method, the former being, perhaps, the simpler.

## 5—DANGER SIGNALS

Finally, conditions sometimes arise in fighting forest fires, especially in mountainous regions when it is desirable to convey instant warning of danger to the men on the fire-line. Many lives have been lost fighting fires and it is the duty of the fire-line foreman to keep a close watch on the behaviour of fires in dangerous localities and to be prepared to withdraw his men to a place of safety. Ordinarily this may be done by messenger, but on the chance that time may be lacking to employ this method it has been considered necessary by some organizations to adopt a set of danger signals. These are best made by revolver shots although whistle blasts may be similarly employed.

## 6—MISCELLANEOUS FOREST SIGNALS

The need for short distance signals arises very frequently in forest work not only in forest protection but in many other lines. Communication across impassable barriers, or between members of survey parties beyond calling distance from each other, or between members of hunting parties within sound but not sight of game are conditions under which some form of visual signal would often be extremely useful. Also in cruising, in some phases of telephone construction (such as pulling wire and slack) and in various other forest activities where members of crews are out of sight but within hearing distance, a simple code of audible signals often saves much time and energy.

# PART II

## FOREST PROTECTION TELEPHONE LINES

### CHAPTER IV

#### PLANNING THE TELEPHONE SYSTEM

##### Section 23—Importance of Preliminary Plans

Too much emphasis cannot be placed on the importance of making a carefully drawn plan of the entire system before starting the construction of any part of it. The longer the line and the greater the number of instruments attached to it, the greater must be the electrical conductivity of the wire used and the higher the resistance of the ringer coils in the instruments. An independent pole line 12 to 15 miles in length on which 6 to 8 instruments are to be placed may be constructed of No. 12 gauge galvanized-iron wire and 1,000-ohm ringers may be employed, while if the same line is to form part of a 100-mile circuit No. 9 gauge wire would be necessary and 2,500-ohm ringers would give the best results. Very long lines might require No. 6 iron wire or it might be necessary to resort to copper which has approximately six times the electrical conductivity of iron wire of the same gauge. This might radically alter construction methods. *It is of vital importance, therefore, that very careful consideration be given to all probable future extensions of the telephone system, so that no type of construction or equipment may be employed which will later prove unfitted to form part of a more extensive system than was at first contemplated.*

##### Section 24—Plans must be based on Definite Area

In planning a system for fire-protection purposes, the basis of all plans must necessarily be a certain area of timber-land of greater or less extent. This area we will assume to be contiguous for, although it is sometimes necessary to include non-contiguous areas in a single protection unit, the variations in condition that may arise in considering non-contiguous areas are so wide that it is difficult to generalize with regard to plans for telephone service for such tracts. Usually where government lands are involved contiguity in adequately sized areas is readily secured. Where private holdings are involved much success has resulted from the organization of co-operative timber-protective associations to include the owners of contiguous areas of timber-land in blocks of sufficient size to warrant the organization of a specialized fire-fighting staff and the construction of a telephone system. Whatever the ownership conditions, however, the basis of all fire-protection plans is necessarily a certain area of timber-land and the more nearly contiguous are all portions of the area, the less per unit of area is the expense incurred in equipping it with forest telephones.

##### Section 25—Primary Stations Requiring Service

Within or adjacent to the area under protection will be found a greater or less number of stations that must be joined together by the telephone system. The most important of these is the headquarters of the supervisor or chief ranger having general charge of the entire territory. Next come the headquarters of the district ranger and of his principal administrative assistants. After these the primary lookout stations, which in a normal season provide for the detection service over the whole tract, must be connected. When this much of the system is completed the main framework has

been provided and future extensions need be made only for the purpose of connecting points of special utility. As a rule, a system which joins all the district ranger headquarters and main lookout stations with the supervisor's office will, in addition, provide connection with a large proportion of all other points on the tract that it is desirable to reach. There may, however, be isolated camps or settlements, secondary lookout stations, or other strategic points that require short branches from the main circuits. It is particularly important, however, to note that the central point in any forest-protection telephone system is the supervisor's headquarters and, therefore, this must be definitely located at the start in the most suitable place, and the system planned accordingly.

Before a system can be intelligently planned the following data must be available in every case:—

- (1) Boundaries of tract.
  - (2) Boundaries of ranger districts.
  - (3) Location of supervisor's headquarters.
  - (4) Location of district ranger headquarters.
  - (5) Location of primary road and trail system.
  - (6) Location of primary lookout stations.
  - (7) Location of existing telephone lines on or near the tract.
- As many other strategic points as possible should also be determined.

### Section 26—External versus Internal Systems

It will be found in planning a system of telephone lines for large areas of timberland that two general cases may be recognized, and the arrangement of circuits must be governed by these general conditions.

#### EXTERNAL SYSTEM

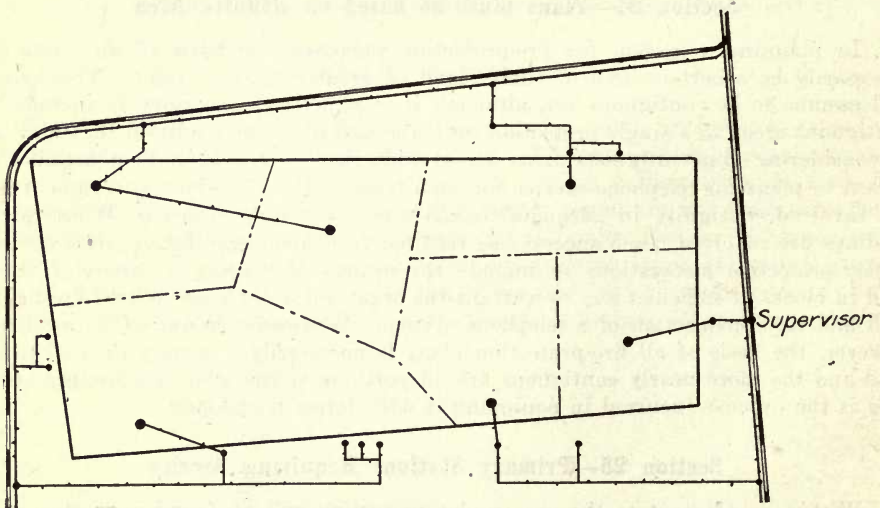

Fig. 3. External telephone system on a forest reserve

#### 1—EXTERNAL SYSTEMS

It not infrequently happens that the forest to be protected is wholly or in large part surrounded by settled lands. This is somewhat more common in the United States than in Canada, but throughout the Prairie Provinces and in parts of British Columbia as well as in some parts of the eastern provinces this condition exists. If

settlement comes well up to the border of the forest land and rural telephone lines are well developed in the settlements, the most efficient system of telephone communication can generally be secured by extending these rural lines into the timber to connect with the headquarters of the various district rangers. In deciding upon this plan it is necessary to weigh the cost of tolls on the commercial and rural lines, and the quality of service rendered, against the original cost of installation and the annual cost of maintenance of an independent forest-protection system. In doing this it must be remembered that only the main circuits can thus be provided for. It still remains necessary to connect the district headquarters with strategic points in the districts. A further disadvantage in having the main circuits outside the forest area lies in the fact that the interior mileage of line, to which connection can be made by portable telephone, is thereby considerably reduced and the average distance that it will be necessary for the patrol to go in order to establish connection by telephone is likely to be materially increased.

2—INTERNAL SYSTEMS

Whenever, as frequently happens in Canada and in some parts of the United States, there is little or no settlement along the greater part of the exterior border of the timbered area it becomes necessary to plan the system wholly within the forest. Certain general principles hold good for such plans regardless of the size of the area involved, providing it is not so large that circuits of impossible length would be needed to reach the more remote districts. For purposes of illustration we may assume an area of 4,000 square miles or approximately 2,500,000 acres. This would, perhaps, be divided into ten ranger districts, each with a main headquarters. Eight lookout stations and 20 to 28 patrolmen and "smoke chasers" would likely be required. This, of course, would vary with the many factors that determine the justifiable expenditure, and cannot be stated arbitrarily.

**INTERNAL SYSTEM**

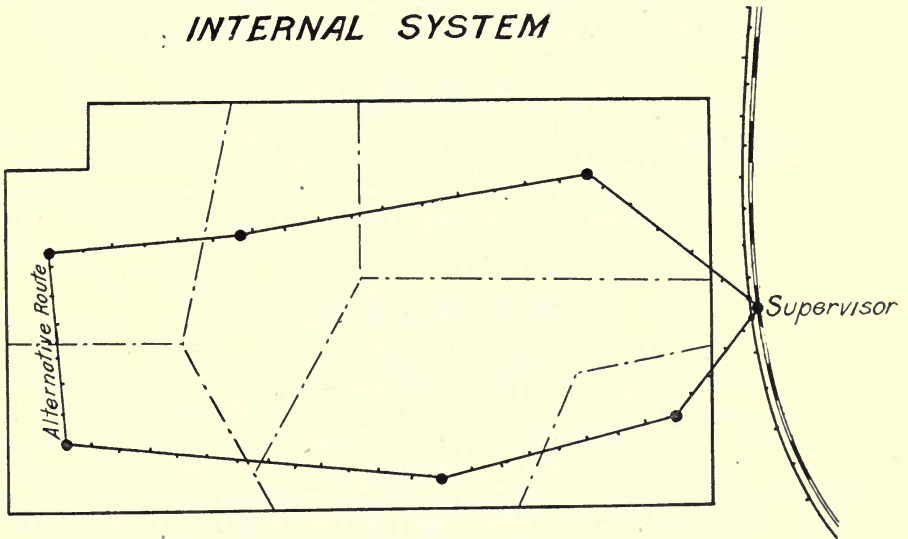

Fig. 4. Internal telephone system on a forest reserve

At some central point, preferably with good mail, telegraph, and railway service, and with large supplies of men and materials, the chief ranger or supervisor will be located. Obviously, a point as near as possible to the geographical centre of the tract should be selected for the main headquarters, unless topography or established lines of communication make some other choice more advantageous. The choice of this

main headquarters, however, is extremely important from every point of view, and it should not be decided upon except after very careful consideration of all factors.

The same is true of the selection of the district headquarters. District boundaries will usually be established on topographic lines; in a mountain or hill country generally along ridge tops, in a flat country along large rivers or lakes. The selection of main and district boundaries and headquarters must be completed as a fundamental preliminary before beginning the planning of the system of communication.

The main principle to be observed in planning an internal system is to have the lines radiate from the main headquarters by the most direct route to each district headquarters. The district headquarters are then used as centrals from which lines radiate to lookout stations and other important points in the district.

This plan has two important advantages. In the first place each of the several independent circuits from the main headquarters to the districts will be much shorter than single circuits connecting several district headquarters on one line. It is always desirable for the purpose of ensuring the maximum operating efficiency to keep circuits to the minimum length.

In the second place a break on any of the main lines under this system will isolate only one district, while under a system of through lines joining a number of districts all or several might be isolated by a single break.

### Section 27—Connections to Lookout Stations

It is important to note also that lookout stations should have direct connection with the main headquarters as well as with the district ranger. This makes it undesirable to introduce a switch between the main line and the lookout station when the line from the lookout station joins the main line at a district headquarters. Isolation of lookout stations must be carefully guarded against, and switches are too likely to be carelessly left open to be tolerated on such lines.

Other important points to consider in planning a telephone system are the location of test stations, of relay calling stations on extra long lines, and the provision of alternate routes.

### Section 28—Test Stations

Test stations are points at which, by means of suitable switches, the line may be broken into sections. Ordinarily they are used for the purpose of determining the location of line troubles within definite limits, but they may be very advantageously used for the relaying of calls over a long or a poorly insulated line. For this purpose it is desirable that they be located at stations where switching service can be relied upon.

### Section 29—Relay Stations.

Relay stations are points on very long lines where it is necessary to repeat long distance calls. With the equipment used on forest telephone lines it is nearly always possible to talk much farther than it is possible to signal with the call bells. Circuits must not be planned to operate regularly on this basis, however, but in very large contiguous areas conditions sometimes occur which make it desirable to consider the possibilities for relaying calls. Under such conditions relay stations may be employed and they must be located at points where continuous switching service is available.

### Section 30—Alternative Routes

Alternative routes are secured by building connecting lines across the relatively short gaps that sometimes occur between the ends of separate branches. They make it possible to reach each station on both lines from two different directions and, therefore, greatly reduce the chance of any one station being cut off from communication. Since

they are not usually depended upon for regular service they may be very cheaply constructed. Often emergency wire laid only during the fire season is employed for this purpose.

These lines should, if possible, be entirely isolated from the regular lines except when in use, unless they are of standard construction. They can generally be rather easily maintained because they are short and have occupied stations at each end. Whenever possible one such station should be a lookout, thus affording an alternative route to the lookout station and ensuring continuous switching service at one end, at least, of the closing line during the fire season.

### Section 31—Secondary Strategic Points

Needless to say, there are many points within or adjacent to a forest area other than headquarters of the protection staff which may advantageously be included in the system of communication. These are usually included in the general term, "strategic points," and include logging, mining, construction, and other similar camps, local settlements, stores, summer resorts, power stations, saw-mills, boat landings, stage stations, ranches, and, in fact, any point where either labour or supplies may be secured in an emergency, or from which reports of fires burning in or adjacent to the forest may be sent. As far as is practicable, the main system should reach these points. Those not so connected may subsequently be reached by spurs if desirable.

## CHAPTER V

### SELECTING THE TYPE OF CONSTRUCTION

For forest-protection purposes two principal types of construction have been employed. These are pole lines and tree lines. Pole-line construction, as used on forest lines, differs in no material aspect from ordinary rural-line methods. Several simple manuals of construction have been published setting forth these methods in detail but for the purpose of making this manual of communication complete a description of these methods will be included.

#### Section 32—Pole-line Construction

Briefly stated a pole line consists of poles of a specified length set firmly in the ground at specified, uniform intervals and bearing glass or porcelain insulators to which the line wire is rigidly attached by short tie wires. Pole lines are as straight as possible. On curves the wire is always placed on the convex side and the sag between poles is only sufficient to allow for the normal contraction of the wire with changes of temperature.

#### Section 33—Tree-line Construction

Tree-line construction is radically different from pole-line construction. As a matter of fact, in most important aspects tree lines are the exact opposite of pole lines. It is important that this be noted, especially when employing linemen who have had previous experience in the building of pole lines. Such experience always predisposes them to follow methods that produce very faulty tree lines, and such men must generally be more carefully supervised when first put on tree-line work than men who have had no previous experience whatever.

Briefly stated, tree lines consist of trees of varying sizes, at varying but as nearly as possible equal distances apart, trimmed of branches on one side to a specified

height above the ground, and serving as supports for a special two-piece porcelain insulator through which the line wire passes without being rigidly attached. Tree lines are never straight as are pole lines. On curves the line wire is always placed on the concave side and there is a very much greater allowance for sag than that required for normal contraction of the wire. Supports on tree lines are generally about 65 per cent greater in number than on pole lines, and sag allowance is from four to six times as great.

### Section 34—Construction Methods Contrasted

Pole lines are built only in open country and along cleared roads or, if they must be carried through timber, a sufficient right of way is cleared to ensure that trees will not fall across the line. They are built rigidly and the wires are expected to stay up unless the poles themselves give way.

Tree lines are designed to be built only through standing timber, where no attempt is made to clear a sufficient right of way to ensure against falling timber. Instead, special construction is used for the purpose of ensuring that when trees fall across the line, the wire *will be carried to the ground without breaking* or, in case a number of trees fall in a short distance, the tie wires will break and a considerable portion of the line wire be brought to the ground still *unbroken*.

A further danger that tree-line construction overcomes arises from the swaying of the supporting trees in the wind. This does not occur in pole lines but is quite obviously a matter of some importance in tree lines. *In short, tree lines are designed to give way and fall to the ground when subjected to unusual strain by falling timber but any breakage that occurs is designed to come in the tie wires and not in the line wire.* The underlying principle is that a broken line wire means a dead circuit but a line wire of a grounded circuit may still function as a telephone circuit when a large part of it is on the ground, or even when buried under dry snow. If the ground is damp it will function very imperfectly and if it lies in a stream or pool of water it is no better than a broken wire, but a considerable portion of a grounded circuit may lie on ordinary dry or frozen ground without entirely destroying the usefulness of the line for telephone purposes.

Tree lines, however, have certain very definite limitations. It is impracticable to use copper wire with this type of construction. This limits the length of tree lines to about 125 to 150 miles using No. 9 iron wire. If it is necessary to build a metallic circuit to ensure against induction it is not practicable to attach both wires to the same supports, as is done with pole lines, but two separate parallel lines must be built. Tree lines are never as perfectly insulated as are standard pole lines and, therefore, are more subject to losses of current and other difficulties in transmission. This is true no matter how well they are built and is inherent in the methods and line equipment employed.

### Section 35—Relative Cost of Different Types

It is a mistake to assume that a tree line is necessarily cheaper than a pole line even where there are sufficient trees available to furnish supports for the line. Particularly is this true when maintenance charges and operating efficiency are taken into consideration.

The only cost elements of pole-line construction that are greater than those of tree-line construction are the cost of the poles set on the line and the cost of right-of-way clearing. The cost of the former will vary with the accessibility and durability of poles, facilities for distribution, and character of the soil as regards cost of digging holes. The cost of the latter depends on the nature of the forest and underbrush.

On the other hand all other cost elements are likely to be higher for tree lines than for pole lines. It is never advisable to use smaller wire than No. 9 B.W.G. iron wire on a tree line. On a pole line, however, No. 12 B.W.G. iron wire may be used on



circuits up to 25 to 30 miles in length. This has only one-half the weight of No. 9, and both the first cost and cost of transportation are, therefore, reduced one-half. There are nearly twice as many ties on a tree line as on a pole line. The cost for insulators is, therefore, considerably increased. As split tree insulators generally cost more per thousand than pony glass insulators and brackets together, this cost is more than doubled on a tree line.

Stringing wire costs materially more on tree lines than on pole lines. This is true even with experienced labour. The most obvious cause of greater cost is the much greater number of ties to be made, as previously mentioned. Further, it is harder to reel out wire for a tree line, and care must be used to get the wire on the right side of each tree, which is less necessary with poles. Trees are also harder to climb than poles, especially where they are large or have a loose, scaly bark, and it is necessary for the linemen to spend much time trimming the trees as they ascend them. Finally, the wire cannot be stretched to give the proper sag allowance in half-mile spans as it can with poles, but the sag must be distributed from tree to tree by the linemen often with the constant assistance of a groundman.

The most difficult element in tree-line construction, however, is the problem of securing efficient labour and supervision. In pole-line work, methods are largely standardized and relatively simple for lines of only one or two wires, such as those used for forest telephone circuits. About the only problem requiring the exercise of judgment is the bracing and guying of poles on curves and at abrupt turns. In tree-line work, on the other hand, nearly every support presents a new problem. Experienced builders of tree lines are practically non-existent in Canada, and attempts to use linemen experienced in ordinary pole-line methods have usually been attended with very unsatisfactory results. Unless, therefore, a large enough mileage of tree line is to be built to justify the training of special line builders, or unless an experienced foreman is available, it will be found more satisfactory to employ the standard pole-line methods even in timbered regions. This will be quite generally true where the timber stand is relatively light, making the clearing of a right of way easy, and where suitable poles of durable species are readily secured along the line.

Where a large mileage of line is to be built in big timber, or where the line passes in large part through large fire-killed, dead, or overmature timber where windfalls are frequent and the cost of right-of-way clearing would be prohibitive, tree-line methods are often the only practicable construction that can be employed. These methods are described in detail in this manual, and if the purpose of the peculiar type of construction employed is understood and the methods prescribed are followed faithfully and intelligently entirely satisfactory lines may be built through the most unfavourable timber at very reasonable cost.

### Section 36—Sketch of the Development of Tree-line Methods

Although thousands of miles of so-called tree lines have been built by railway construction companies and others for temporary use, the credit for devising a method by which tree lines may be built to be of permanent utility belongs to the United States Forest Service. This service has approximately 25,000 miles of lines in use on the National Forests of the United States, a large part being tree lines, and is constantly extending these lines as funds become available. The experience on which its methods are based has been secured under the personal direction of expert telephone engineers on thousands of miles of line constructed over a period of fifteen years. Beginning with the makeshift methods of construction commonly employed for temporary low-priced lines by railway contractors, there has rapidly been developed under actual working conditions a low-priced method for building permanent lines specially adapted to forest conditions, and a large amount of equipment has been designed to meet the special conditions encountered on these lines. The first tree lines built followed rather closely pole-line methods. These rapidly became useless.

A less rigid type of construction being evidently required, the line wire was hung in loops from the insulators instead of being rigidly wired to them. This was quickly superseded by a porcelain knob which took the place of the wire loop, and these in turn were displaced by the split porcelain insulator. The latter has undergone several important modifications from the original style in order to meet field conditions more perfectly.

Meanwhile, there has been a steady improvement in the method of attaching the insulators to trees. Plain wire hangers fastened with fence-staples were first employed. These have given place to various other forms of hangers and fasteners until there are now a variety of improved methods of attachment suited to special conditions. The importance of abundant slack and of equalized spans was not at first fully perceived. Experience soon demonstrated that these features of tree-line construction were vital, and, however much the appearance of the resulting line might depart from previously accepted standards, the conditions had to be met.

Simultaneously there were developed several improved forms of instruments for field use. At first the only portable instruments available belonged to two very specialized classes—linemen's test sets and military field sets. The latter were not readily procurable, were expensive, and were not well adapted for use with the types of station equipment generally employed on forest lines. The former, although cheap and adapted to the station equipment, were heavy if sufficiently powerful, awkward to carry, and poorly designed for rough usage. By combining the good points of each class a portable telephone of less than 10 pounds weight was first designed. Subsequently, by adopting from military telephones the vibratory system of signalling, a field set of only 2 pounds weight was obtained.

While both the methods and equipment have been thoroughly tested in the field and are known to be reliable, nevertheless, the Forest Service engineers would be the last to claim that their methods are susceptible of no further improvement. In fact, new methods are constantly being devised and this is especially true where forest-protection lines are built in new regions. Several novel conditions have already been encountered in Canada that have called for special methods, but changes in methods by inexperienced builders where field conditions present no striking novelties are to be avoided. The author has seen this attempted with distinct lack of success on several occasions and wishes to strongly deprecate any attempts by *inexperienced* tree-line builders to improve on the methods of the Forest Service as reprinted in this manual.

### Section 37—Influence of Timber Conditions on Choice of Construction Type

A word about the types of Canadian timber to which one or the other of these methods is likely to be better adapted may be in order. In many Canadian forest regions untimbered areas of greater or less extent occur. These are more common in western than in eastern forests and are particularly abundant in the Rocky Mountain forests and in the drier portions of the British Columbia interior. Wherever it is possible to build forest lines in these open meadow lands it should be done. If durable poles are reasonably accessible the first cost will be only slightly increased, and the greatly reduced maintenance charges and superior transmission secured will amply justify any small extra expenditure for construction.

#### 1—MERCHANTABLE TIMBER

The types of timber most favourable for tree-line construction are those with little or no underbrush and only moderately dense stands of trees of small size (10 to 15 inches in diameter at breast-height), with trunks clear of branches to a height of 20 to 25 feet or with only small pin branches, and with thin, tough bark. To these belong the lodgepole pine stands of the West, which are the most favourable of all

stands for tree-line work, and the jack pine stands of the East. Somewhat less favourable are the stands of eastern red pine, of western larch, and western yellow pine in mixture, Douglas fir on the drier soils, and some of the larger-sized pure poplar stands both East and West.

Next to these species in ease and low cost of tree-line construction are such stands as western white pine (where relatively pure), eastern white pine, mixed hardwoods in the East, Engelmann spruce and amabilis fir at high elevations, and the larger-sized western yellow pine and Douglas fir on dry sites. In the first three the underbrush is likely to be heavy and the bark thick on old trees or the branches abundant on young trees. In large yellow pine and fir some difficulty is experienced in climbing trees because of their size and loose bark, and where trees stand in the way of the line they are very costly either to fell or to trim up. High-altitude stands are usually fairly clear of underbrush and the trees are a fair size if usable at all, but the branches are dense.

The most difficult types through which to build tree lines are Douglas fir on wet sites on the Pacific coast, white spruce or red spruce, Engelmann spruce at low elevations, cedar, and, above all, hemlock, especially western hemlock. The mixed coniferous forests of the moister regions of British Columbia come under this head, as well as a great deal of the northern forest belt and the eastern spruce forests. The difficulties encountered in these types arise from the large amount of underbrush that has to be cleared, the density of the timber, and the low-branching habits of these species. Hemlocks are particularly bad because the lower branches are excessively long and have a very pronounced downward sweep. Often large branches of hemlock have to be cut from trees standing 15 to 20 feet to one side of the line in order to free the wire.

## 2—YOUNG TIMBER

In building lines through very young timber or reproduction of any species there is often no choice as to type of construction that may be employed, since none of the young trees may be large enough to serve as supports. Very often, however, there are standing dead snags as remnants of the original forest, which may be so utilized. Unless the necessity for economy is very great or poles are extremely inaccessible, the use of such snags for long lines is not advisable. If used, care should be taken to see that as many as possible of the dead trees adjacent to the line are felled, that abundant slack is left in the line, and that it is made easily accessible for the purposes of repairs, as maintenance charges are likely to be high. The continued felling of nearby snags should be made a part of the regular work of the protection staff and a gradual replacement of the tree line by a pole line should be the object of the maintenance work.

If young timber, of such a size that trees large enough to furnish supports are available, is encountered very careful consideration should be given to the advisability of adopting pole-line construction. A decision will be based largely on the cost of right-of-way clearing which is determined by the size and especially by the density of the young stands. Where these are very open, pole lines will usually be preferred. A makeshift method of construction sometimes adopted under these and similar conditions consists in making the necessary right-of-way clearing, often in the form of a wagon road, but leaving at the required intervals suitable trees to serve as the supports for the telephone line. These trees should not be topped. The cost of making and setting poles is thus saved but it must be realized that a line thus located is likely to interfere with the use of the road and that provision for replacing these supports with poles must be made a part of the work of line maintenance.

A similar situation is often met by the builder of forest telephone lines, even in certain species of timbers of commercial size in the forests of the Prairie Provinces and of the East. This is most likely to be the case in poplar or jack pine stands. Both species frequently grow in rather open forests, and where they occur in such stands right-of-way clearing is comparatively inexpensive. Moreover, unless the

poplar is old and defective, windfall is light and the width of clearing need not be excessive—20 to 25 ft. in stands of sound green timber not over 40 to 50 ft. high being adequate. Care should be taken to cut all snags or defective trees, outside this right of way, that threaten to fall on the line.

### 3—DEAD TIMBER

There remains then only the question of dead standing timber. This is the most troublesome kind of stand through which to build and maintain a telephone line. Whenever possible, such timber should be carefully avoided, even at the expense of a material lengthening of the line. The foregoing applies not only to forests in which all the trees are dead but also to forests in which a considerable proportion of the trees are dead or badly decayed and where windfalls are consequently frequent and such forests are extremely undesirable along the line. Where, as sometimes happens, it is entirely impossible to avoid constructing through such stands and an adequate right of way cannot be cleared, then the most careful attention must be given to the details of tree-line construction and *the line must be constantly maintained in first-class condition*. This latter is of extreme importance because the accumulation of several fallen snags across the line in a short distance will take up all the slack and cause the intervening portions to be drawn up very tightly. If this tight wire should happen to be caught on a projecting branch, or even if the ties fail to break as quickly as designed, then any new windfalls coming on the line will very likely cause a break. Even if no break occurs the line is sure to be very seriously strained and a large number of ties pulled off or broken, insulators smashed, and general havoc created. Only by careful and conscientious maintenance may lines be kept operating through large dead standing timber where windfall is frequent.

### Section 38—Grounded versus Metallic Circuits

A grounded circuit is one in which only a single wire is employed for the transmission of the calling and talking currents and the earth is utilized as the other half, or return portion, of the circuit.

A metallic circuit employs two wires, the extra wire taking the place of the earth or return portion of the circuit in a grounded line.

Contrary to what appears to be popular opinion it is not necessarily possible to talk farther over a metallic than over a grounded circuit. On the contrary, since the earth for all practical purposes may be assumed to interpose no resistance to the return currents, provided the ground connections are well made and do not themselves offer a higher resistance, a grounded circuit will have only one-half the electrical resistance of a metallic circuit under similar conditions. From this it does not necessarily follow that it is possible to talk twice as far over a grounded circuit, because conditions other than the mere electrical resistance of the intervening wire have an important influence on the possibilities of long distance telephonic transmission. The usefulness of metallic circuits arises from the possibilities of eliminating from them, by suitable transpositions, all induced currents from other electrical circuits such as power, light, telegraph, or telephone lines that may exist in their vicinity. The extraneous noises or cross-talk on a grounded circuit of even short length which runs close to such currents often make distinct speech transmission impossible, regardless of the electrical resistance of the line itself. By using a two-wire, or metallic, circuit such interference from outside sources may be eliminated by transposition, and communication is thus rendered possible where a one-wire, or grounded, line cannot be used at all. Where, however, difficulties in transmission arise, not from interference by induced currents but from excessive length of lines, poor insulation, bad joints, poor "grounds," or other defects in construction, the installation of a metallic circuit will give no relief. Excessive line length can only be remedied by using a more efficient conductor. Thus,

the standard galvanized-iron wire used in ordinary forest lines would have to be replaced by a larger wire or preferably by copper wire, which is a much more satisfactory electrical conductor than iron wire. If the trouble arises from faulty construction it can only be remedied by removing these faults. The installation of a second wire would, otherwise, be more likely to increase than to decrease the difficulties.

For forest-protection purposes a grounded line is nearly always preferable to a metallic line. As previously stated, only grounded lines can be satisfactorily employed in tree-line construction. The employment of two wires not only magnifies the chance for interruptions due to breaks in the line but also renders a metallic line liable to interruption from short circuits in ways that do not occur with grounded lines. Thus, if the two wires became crossed, as would often happen when a tree fell across the line, or if a wet branch or a loose tie wire fell across both wires, the line would fail to work. Metallic circuits, therefore, should as a rule only be used on full pole lines and then only when needed to counteract interference from induced currents. Where disturbances due to induction are encountered in only a part of a line, it is not necessary to make the entire line a metallic circuit, but only that portion where the disturbance occurs. The means by which this is accomplished will be discussed in Chapters XII and XIV (See Figs. 56, 58, 59, 60 and 86).

## CHAPTER VI

### TELEPHONE CONSTRUCTION POLICY IN DOMINION FOREST RESERVES

#### Section 39—Construction by the Forestry Branch

The intention of the Forestry Branch is to secure efficiency of fire protection on the forest reserves by such specialization as the controlling factors seem to warrant. This will involve the establishment of rapid means of intercommunication. To accomplish this, telephone lines have been built and will be extended wherever their use will ensure more effective fire protection and more economical administration, and where the territory covered is not served, or probably will not be served, by commercial lines on account of inaccessibility and absence of subscribers. In general, telephone lines on the forest reserves will be located in accordance with the principles already discussed in Chapters IV and V.

For the most part, the commercial telephone lines near the forest reserves are owned and operated by the government of the various provinces, except in British Columbia where they are largely operated by the Dominion Department of Public Works. Wherever feasible, these lines should be utilized in order to lessen the necessary construction of Forestry Branch lines.

#### Section 40—Co-operative and Private Lines

Co-operation between the Forestry Branch and companies, individuals, provinces, or other government departments that would involve joint ownership, construction, or maintenance of telephone lines, introduces a division of responsibility which may affect communication and maintenance as well as future growth and extensions, and, therefore, should be avoided. Exceptions may be made in the case of the lines of the Department of Public Works in British Columbia and, in unusual instances, in the case of provincial telephone departments, but all such instances must be referred to the Director of Forestry for approval.

The construction of privately owned lines within the reserves should be encouraged. Permits for such lines, when they will be of material benefit to the forest reserve should be recommended for issuance under Regulation 65 ("Regulations for Dominion Forest Reserves," 1916) and the conditions varied so as to afford the necessary encouragement in each case. Regulation 21 authorizes the granting of free construction materials for structures on roads and trails on condition that they become the property of the Crown, and Regulations 18 and 19 provide for the furnishing of materials at special rates when the removal of the material will benefit the reserve. Supervisors, therefore, should accompany all recommendations for issuance of permits for the construction of private telephone lines within forest reserves by a report regarding the class of construction materials that it will be necessary to obtain from the forest reserve, if any, and a recommendation regarding the price that should be charged in case special consideration is believed justifiable. Free service for a specified number of connections made by the Forestry Branch on all such lines will be made a part of all such permits.

### Section 41—Use of Forestry Branch Lines

The connection of privately owned instruments with Forestry Branch lines will not be permitted. The conditions under which these lines are constructed and maintained necessarily reduces to a minimum the number of telephones that may be operated on them. Each telephone adds to the electrical load and lessens by this amount the reserve capacity for future growth and, more particularly, for emergencies. Under no circumstances can such a number of instruments be regularly connected to a Forestry Branch line that its entire capacity is employed, since the exigencies of forest administration may at any time require the establishment of one or more additional temporary connections with portable instruments or emergency lines. The possibilities of extensions are also extremely important in this connection. A line 10 miles long might easily carry ten to fifteen telephones, but if this line is extended to form part of a circuit 100 miles long the probability is that all but one or two of these telephones would have to be removed in order to get any use of the line. Now, it is found that where telephone service has once been granted in an isolated region it is relinquished only with the greatest reluctance and therefore forest officers should weigh all these points very carefully when considering any connections other than those at ranger stations.

All instruments connected with a Forestry Branch line will be provided, installed, and maintained by the Forestry Branch. Instruments may be installed by supervisors at logging camps, mines, or other private establishments, but only where such installations are necessary for the proper administration and protection of the forest, where suitable arrangements can be made for the protection of the instrument and the securing of access to it by forest officers at all times, and only after approval of the installations has been received from the district inspector. It will be the duty of supervisors contemplating such installation to report fully to the district inspector the conditions which warrant the placing of an instrument at that point, the character of the building in which it will be placed, and the service that may be secured, and to report annually as to the advisability of maintaining or discontinuing the installation. Such stations will, as a rule, be located only in buildings of a public or semi-public character such as stores, post offices, hotels, road-houses, logging-camps, etc., and only where the location is of material importance to the reserve work and the person owning the establishment is under agreement to perform some special service for the Forestry Branch.

The telephone lines of the Forestry Branch are not to be considered commercial in character. It is not the intention to enter into competition with any private or provincial telephone service. Hence no action such as the granting of telephone services to settlers along these lines, with an annual charge for the privilege, will be permitted. It is obvious that any such permits will inevitably raise the question of

discrimination, since it is wholly unreasonable to expect that such service can be granted to all that may apply, as would be done on commercial lines. These lines are built for the specific purpose of assisting in the administration and protection of the forest reserves, their capacity is extremely limited, the connections needed by the Forestry Branch are subject to sudden and unforeseeable increases, and accidents to which these lines are particularly liable may at any time very greatly impair their carrying capacity. For these reasons any attempt to render commercial service will inevitably fail, and no connections will be made which are not in the opinion of the supervisor and the district inspector essential to the proper administration and protection of the reserve.

Forestry Branch lines, however, are open for public use free of charge so far as the portion of the line owned by the Forestry Branch is concerned. Where provincial or other foreign lines are used in connection with a forest line the usual toll charges must be paid.

### Section 42—Telephone Improvement Plans

Within one year after the issuance of these instructions all supervisors and rangers in charge of Dominion forest reserves are required to prepare and submit to the district inspector and the Director of Forestry a complete plan for the equipment of the reserve with telephone lines. This plan will include a map and a report.

The map should show existing Forestry Branch and private lines and their character, and the location of exchanges and instruments, also the location and character of all new construction which will be necessary to meet the needs of Forestry Branch business during the next five years. In addition, the map should show high-tension electric transmission lines, roads, trails, ranger stations, lookout stations, and all other features which may influence the establishment of the system.

The report should discuss, in the order of their importance, the proposed new lines, their need, location, character, and cost. The telephone system should be grouped by natural divisions, each being designated by its two terminals. A branch line should be designated by its terminal and the division of which it is a branch.

The district inspector will prepare, from the information furnished by the supervisors, a map of the entire district showing the existing and proposed lines. This will ensure co-ordination of plans between the various reserves and with private systems. He will then issue instructions covering the general plan of the telephone system for each reserve.

### Section 43—Standard Methods

Since the Forestry Branch lines are primarily for fire protection purposes they should embody the best principles of construction, and every precaution should be taken to ensure continuity and dependability of communication over them at all times and especially during fire seasons.

#### 1—DESIRABILITY OF STANDARDS

To ensure that the best principles of construction shall be followed on all reserves it is essential that the direction of telephone development be centralized and this necessarily involves the issuance of uniform standard instructions. Such standard methods may be based on the experience, not alone of all the various Forestry Branch officers, but also on that of other protection services, and new discoveries or improvements can, therefore, be applied generally throughout the forest reserves. Moreover, it is only by employing standardized methods that the use of standard equipment is made possible.

#### 2—AMOUNT OF LINE WARRANTED BY PROTECTION STANDARDS

As yet, the determination of exact standards of protection on forest lands in Canada has progressed only a relatively short distance. It is possible to give only

very general statements in regard to the actual degree of immunity from fire damage that may be considered satisfactory in specific instances, consequently, it is possible to state only in a very general way the amount of line that may be considered essential in any given case. On the forest reserves, where continuous forest production must be aimed at in order to justify their existence, it is obvious that if the area annually burned over averages more than about 1 per cent this aim will be rendered wholly unattainable. It is doubtful, moreover, whether with an average annual fire loss exceeding one-tenth of 1 per cent (1 acre per 1,000) of the area protected satisfactory results are possible. Certainly an average annual loss of 2 acres per 1,000 in the reserves of the Prairie Provinces should be the outside limit. What expenditure may justifiably be made to attain this degree of protection depends on many factors, not all of which are as yet known in these forests. From a study of protective services in other regions, however, it may be said that present protection standards on Dominion forests demand the connection of all district ranger headquarters with the supervisor by telephone, and the equipment of primary lookout stations at least. Further construction can only be of real utility as the efficiency of the staff develops and as its further specialization becomes feasible. In a general way an internal system that will connect all district headquarters with the supervisor will be found to involve about 200 miles of line to each million acres of forest. Since this is a greater mileage than can be successfully operated on one circuit, it is necessary to divide it into two or more independent circuits in preparing the telephone plan.

**Section 44—Standard Materials**

**1—DESIRABILITY OF STANDARDS**

Several factors combine to render the adoption of equipment standards imperative.

Certain technical reasons require the use of uniform types of instruments on the one circuit.

Only by adopting a standard type for all circuits is it possible to connect up adjacent ones or to transfer equipment from one to another.

Some important special instruments are manufactured for use only with certain types of equipment. Unless these types are employed it is impossible to utilize all the available facilities.

Dealers will carry in stock only materials for which there is a reasonable demand. The adoption of uniform standard equipment for all the work of the Forestry Branch will make it possible for dealers to carry at local distributing centres a supply of this material, and thus greatly expedite deliveries.

For the purpose of providing uniform equipment throughout the Dominion forest reserves the following standard list has been adopted and must not be deviated from without the authority of the district inspector.

**2—LIST OF STANDARD EQUIPMENT**

NOTE.—For specifications of those items marked with an asterisk (\*) see Appendix E.

<i>Material and Uses</i>	<i>Description of Equipment</i>
--------------------------	---------------------------------

\*Wire :—

Standard

Line (pole and tree, grounded and metallic). No. 9.	B.W.G., B.B. galvanized-iron telephone wire.
---	--

Specials

Line (special long distance tree lines, grounded only) . . . . .	No. 6 B.W.G., B.B. galvanized-iron telephone wire.
--	--



*Material and Uses—Con.*

*Description of Equipment—Con.*

*Wire—Con.*

- Line (special short pole lines only) . . . . .Nos. 12 and 14 B.W.G., B.B. galvanized-iron telephone wire.
- Line (special extra long distance pole lines only, mostly metallic) . . . . .Nos. 8 and 12 and 14 B. & S. gauge hard-drawn copper as required.
- Line spans, 500 feet and over . . . . .Steel wire as required.
- Emergency lines . . . . .No. 20 stranded, consisting of 10 strands of No. 30 B. & S. gauge, hard-drawn copper wire, insulated.
- From line to fuse . . . . .No. 14 B. & S. gauge, rubber-covered, braided, weather-proofed copper wire. Single for grounded line, twisted-pair for metallic.
- From fuse to protector . . . . .No. 14 B. & S. gauge, rubber-covered, braided, weather-proofed copper wire. Single for grounded line, twisted-pair for metallic.
- From protector to all inside apparatus, including telephone . . . . .No. 19 B. & S. gauge, rubber-covered and braided copper wire. Single or twisted-pair.
- From protector to ground . . . . .No. 14 B. & S. gauge, rubber-covered, braided and weather-proofed copper wire. Single.
- From line wire to portable telephone . . . . .Special Forestry Branch portable connector.

*\*Poles:—*

- Line supports (standard) . . . . .22½ ft. long by 6 in. diameter at top. Green, or sound dead, peeled cedar, or other species, with open tank butt treatment.
- Line supports (special) . . . . .18-ft. to 45-ft. cedar poles for special construction. Species other than cedar with special treatment.

*Attachments, Wire to Poles:—*

- \*Brackets . . . . .12-in. oak bracket, painted or oiled.
- Nails . . . . .6-in. and 4-in. galvanized-iron wire nails.
- \*Insulators . . . . .Glass, regular pony long-distance 14-oz., deep groove for No. 9 iron wire. Glass No. 9 pony for copper and No. 12 iron wire.

- Tie Wires . . . . .No. 9 B.W.G. galvanized-iron wire on No. 9 wire lines. Nos. 8, 12, 14 B. & S. gauge, *soft* copper wire on same gauge copper lines.

*Attachments, Wire to Trees:—*

- Fastener . . . . .3-in. or 4-in. wrought-iron staples, according to bark thickness.
- Tie Wires . . . . .Nos. 9 or 12 B.W.G. galvanized-iron wire, according to tie employed.
- \*Insulator . . . . .No. 37 improved split tree insulator No. 6651.

*Linemen's Tools:—*

- Climbers . . . . .Eastern type (in ordering state length desired) straps and pads are supplied separately.
- Belts with rings and safety straps . . . . .2½-in. (in ordering state length desired).
- Pliers, for cutting wire and making ties and splices . . . . .8-in. linemen's side-cutting, with sleeve-twister, Klein make or equal.

- Combination wire and sleeve splicing-clamps, for making splices . . . . .Reversible for sleeves (Nos. 8 to 12) and wire (Nos. 6 to 14), Klein make or equal.

## Material and Uses—Con.

## Description of Equipment—Con.

*Linemen's Tools—Con.*

Hand-axe for trimming trees and driving

nails and staples. . . . . 26-oz. Hudson Bay hand-axe with 22-in. handle.

McIntyre sleeves, for splicing copper wire..Nos. 8, 12, and 14 copper McIntyre sleeves for copper wire only.

*Pole-setters' Tools:—*

Shovels, for digging holes for poles. . . . . 7-ft. handle, round point.

Digging spoons, for digging holes for poles..7-ft. handle, flat-toed, medium.

Combined digging spud and tamping bar, for digging holes and tamping poles in *soft* ground. . . . . 8-ft., steel.Digging and tamping bar, for digging holes in *gravel* or *hard* ground. . . . . 1-in. octagonal steel, 8 ft. long.

## Specials

Pike-poles, for raising and steadying poles

30 ft. and over in length. . . . . 12 ft., 14 ft. and 16 ft. long, according to length of poles.

Pole supports, for raising large poles. . . . Mule or jenny pattern, generally made on the job if required.

Post-hole auger, for digging holes in *soft*

ground. . . . . 10-in. auger, Iwan's type with 6-ft. handle.

*Guys and Braces:—*

Bolts, for holding top of brace to pole. . . . . ½-in. galvanized-iron bolt, square head, square washers, 2½ by 2½ by ⅜ in. and nut. Lengths according to size of poles.

Guy rods, for fastening guy wires to anchor

logs. . . . . ½-in. diameter by 5 ft. or 6 ft. long, galvanized-iron with washer and nut.

Guy wires, for guying poles at sharp turns,

long spans, etc. . . . . Nos. 9 or 12 B.W.G. galvanized-iron wire, 2 or 4 strands, twisted.

*Line-stringing Tools:—*

Pay-out reel, pole and tree lines. . . . . Horizontal type only. Made on job according to specifications.

Pay-out reel, emergency wire lines. . . . . Special Forestry Branch hand-reel made to order only.

Buffalo grips, for holding and stretching wire

on pole lines only. . . . . Buffalo grips with pulley for No. 9 wire and smaller.

Haven clamp, for holding and stretching guys

and line wire. . . . . Haven clamp with 2-in. to 3-in. double blocks and 36 ft. of ⅜-in. sash cord.

*Telephone Instruments:—*

For supervisors' offices. . . . . Desk set: type, Northern Electric No. 1300-A or equal. (Note.—When it is desired to equip a desk set with a head receiver the district inspector will advise as to the equipment to order).

For lookout stations, permanent. . . . . Same as for supervisors.

For ranger stations permanently occupied. . . . Wall set; type, Northern Electric No. 1317-S or equal, with 2,500-ohm unbiased ringer and condenser.

*Material and Uses—Con.**Description of Equipment—Con.**Telephone Instruments—Con.*

For ranger and patrol stations unoccupied during winter months, open lookout towers and any *outdoor* stations along patrol routes or elsewhere. . . . . Weather-proof iron box telephone; type, Northern Electric No. 1336-J or equal with 2,500-ohm unbiased ringer and condenser.

For speeder patrolmen, special crews, or fire-camps on lines not equipped for buzzer signalling. . . . . Special Forest Service portable telephone; Northern Electric No. 1375-A.

For patrolmen, special crews, "smoke chasers" and all field service units on lines equipped for buzzer signalling. . . . . Special Adams portable telephone; Northern Electric No. 1004-A.

*Emergency Telephone Kits:—*

For temporary camps on fires or special projects. . . . . Special Forestry Branch emergency communication kit No. 1-A.

*Protective Devices:—*

Lightning-arrester, for lightning only. . . . . Protector; type, Northern Electric No. 60-E or equal. Order separately protector blocks, Northern Electric Nos. 20 and 21 or equal, and No. 10 protector block mica.

Lightning-arrester, for lightning and high-tension currents. . . . . Protector; type, Northern Electric No. 58-F or equal. Same as above with addition of 2-ampere to 7-ampere No. 11-C tubular fuses.

Fuses, for outdoor installation. . . . . Type, Northern Electric No. 47-A or equal.

Protector blocks and micas for repairs. . . . . Protector blocks; type, Northern Electric Nos. 20 and 21 or equal. Protector micas; type, Northern Electric No. 10 or equal.

\*Switch and protector mounting-box, for all permanent outdoor telephones. . . . . Type, Northern Electric No. D-400 or equal.

Protector mats, to be placed under No. 58-F protector. . . . . Type, Northern Electric No. 48 or equal.

Lightning rods, for carrying lightning to ground, on pole lines only. . . . . No. 9 B.W.G., galvanized-iron wire, 2-in. galvanized-iron fence-staples.

*Dry Batteries:—*

For station telephones, desk and wall sets. . . . . Type, Northern Electric "3 in 1" battery Blue Label, or equal.

For weather-proof lookout telephones. . . . . Type, Northern Electric telephone battery or equal.

For Forest Service portable telephone No. 1375-A. . . . . Columbia O.V. No. 3 or Ever Ready Tungsten No. 703.

For Adams portable Telephone No. 1004-A. . . . . Ever Ready Tungsten No. 705.

*Special Signalling Devices:—*

## Extension bells

For stations indoors. . . . . Type, Northern Electric No. 127-F or equal, with 2,500-ohm unbiased ringer.

*Material and Uses—Con.**Description of Equipment—Con.**Special Signalling Devices—Con.*

- For statons outdoors. . . . . Type, Northern Electric No. 292-U or equal, with 6-in. galvanized gongs and 2,500-ohm unbiased ringers.
- Howlers, for signalling by means of vibratory currents as with 1004-A telephone. . . . . Type, Northern Electric No. 1-C or equal.
- Condenser, for use with howler to impede bell-signalling currents. . . . . Type, Northern Electric No. 21-F or equal.

*Repeating Coils:—*

- For connecting grounded to metallic line or taking out a phantom circuit. . . . . Repeating coil; type, Northern Electric, No. 47-A or equal.

*Station Installations:—*

- Fasteners for outside wiring. . . . . No. 4½ solid, or No. 5½ one-groove, split porcelain insulator; Nos. 14 or 16, 3-in. flat-head wood screws.
- Fasteners for inside wiring, single or double. . . ½-in. or ¾-in. Blake insulated staples.
- Fasteners for inside wiring, double only. . . ⅝-in. milonite nails.
- Insulation for wires through walls. . . . . Porcelain tubes, unglazed, diameter ⅝-in. by 1¼-in. Length according to wall thickness.
- Switches, for test stations, central switching stations, unoccupied stations, etc. . . . . Single or double pole 15-ampere baby knife-switches on porcelain bases.
- Screws, for attaching protectors, switches, howlers, etc., to walls. . . . . Blued, round-head screws, length and gauge according to size of each article.

*Installation and Repair Tools:—**Pliers*

- For cutting insulated wire. . . . . 5-in. oblique, side-cutting pliers, Klein or equal.
- For tightening binding-posts and small nuts. 5-in. or 6-in. long-nosed, oval, side-cutting pliers.

*Screw-drivers*

- For setting small wood screws. . . . . 4-in. machinists' style screw-driver.
- For setting large wood screws. . . . . 8-in. machinists' style screw-driver.
- For setting screws in instruments. . . . . 2½-in. machinists' style screw-driver.

Knives, for general insulated wire work. . . Electricians' knife; type, Northern Electric No. 402 or equal.

Soldering torch, for heating soldering irons. Clayton and Lambert gasolene blow torch No. 38.

*Soldering copper*

For soldering joints and other outside work. ½-pound standard soldering copper.

For interior work and repairs to instruments. . . . . Pony soldering copper. No. 2, 11½-in. handle, weight, 3 oz.

*Installation and Repair Supplies:—*

Solder. . . . . Resin-core flux solder, 1-pound or 5-pound spools, half-and-half bar solder.

Flux. . . . . Allen soldering stick, 1 by 5½-in.

Tape. . . . . Black friction tape, ¾-in. Northern Electric grade A or equal.

*Material and Uses—Con.*

*Description of Equipment—Con.*

*Grounding Devices:—*

- Ground rods, for all ordinary indoor and outdoor instrument installations on grounded lines. . . . . Galvanized-iron ground rod with copper wire attached;  $\frac{3}{4}$  in. diameter by 7 ft. long, Northern Electric or equal.
- Ground rods, for metallic circuits only. . . Galvanized or plain iron ground rod,  $\frac{1}{2}$  in. diameter by 6 ft. long, Northern Electric No. 388 or equal.
- Ground plates, for special ground installations. Copper plate No. 21 Birmingham sheet metal gauge or No. 21, U.S. sheet metal gauge; 12 by 18 in. or larger.
- Ground clamps, for grounding on water-pipes. . Northern Electric type A ground clamp or equal.
- Portable ground rod, for Forestry Branch emergency communication kit No. 1-A. . . Special Forest Service portable ground rod, Northern Electric No. 313-B.

*Miscellaneous Tools and Supplies:—*

- Brace and bits, for boring holes for brace bolts and guy rods and for carrying wires through walls. . . . . Brace, ratchet, ball-bearing head, 10-in. sweep. Bits, auger or car bits;  $\frac{1}{2}$ -in.,  $\frac{5}{8}$ -in.,  $1\frac{1}{16}$ -in., countersink. Other sizes as required.
- Claw-hammer, for interior installations. . . Ordinary style; light.
- Monkey-wrench, for setting up brace bolts and guy rods. . . . . Standard wrench, 12-in.
- Pole-steps, for poles over 30 ft. high, bearing test station or other special apparatus. . Galvanized-iron poles-steps,  $\frac{5}{8}$ -in. by 9-in.
- Tree-trimmers, for trimming small branches from ground. . . . . Type, Northern Electric Co., New Giant tree-trimmer or equal.
- Insulators, strain, for dead-ending line wire on trees and poles. . . . . Type, White Strain Insulator No. 500 or equal.
- Strand, standard galvanized steel, for attaching strain insulators. . . . . No. 18 double galvanized-steel seizing strand.

## CHAPTER VII

### OPERATIONS PRELIMINARY TO CONSTRUCTION

#### Section 45—Factors Influencing Location

The relation of the proposed line to the telephone system, present and proposed, should be kept constantly in mind. This will influence the type and character of construction. If the proposed line is a trunk line the possibility of connecting to it short branch lines from lookout points and ranger and fire stations should be considered.

The following additional points should be observed when locating telephone lines:—

(1) The location of the most logical switching centres for connection with other lines.

(2) Topographical location. By avoiding steep slopes, cliffs, high divides, riverbeds, coulees, and streams, and canyons more than 500 ft. in width, the danger from snowslides, landslides, floods, and high winds will be lessened. By following roads and main trails frequent inspection will be facilitated and maintenance simplified.

(3) Location of other electrical circuits. Electric-light, power, and high-tension transmission lines should be avoided whenever possible. A high-tension transmission line carrying over 5000 volts should not be paralleled at a distance of less than one-half mile, and all crossings and approaches between telephone and power transmission lines should be at right angles.

(4) The probabilities of future growth and extensions.

(5) The length of the line. Other costs being equal, the cost of construction and maintenance varies as the length of the line.

#### Section 46—Survey of Route

A preliminary survey or reconnaissance is necessary in order that the length of the line may be ascertained and its cost estimated. The thoroughness of the survey will depend upon local conditions. A transit line with chained distances may be necessary in some cases, while in others a walking or riding reconnaissance will be sufficient. The location determined by the survey, however, need not be taken as final; deviations from it should be made if it is found during the course of construction that greater reliability can thus be secured.

Whenever a pole line is to be constructed, either in whole or in part, marking stakes should be set in line at the proposed locations of the holes. Each stake should be marked to indicate the height of the pole for that particular position, the depth of the hole, the kind of hole to be dug (whether an anchor-hole or a stub-hole), whether the pole is to be guyed or braced, and the amount of the rake (Fig. 11) at curves and corners.

Each tree that is to be used as a tie tree should be prominently blazed fore and aft, and on the side to which the split insulator is to be attached. A cross made with blue crayon should be placed on the latter blaze.

#### Section 47—Securing Right of Way

If it is proposed to build any part of the line off the reserve, or over alienated land within the reserve boundary, right of way should first be obtained. The proper form, which will be furnished by the district inspector, should be used. Verbal permission is not sufficient.

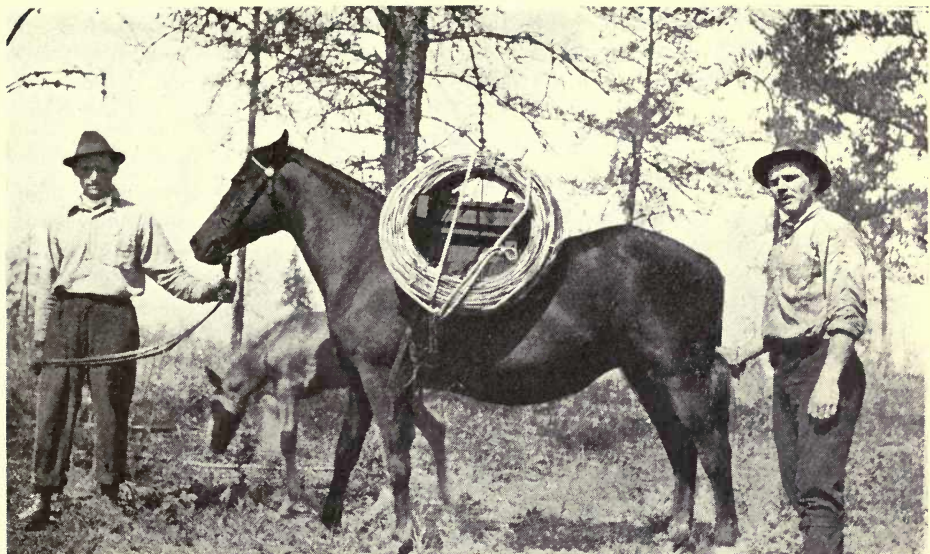

Fig. 5 Mobley wire-cradle as used with two coils

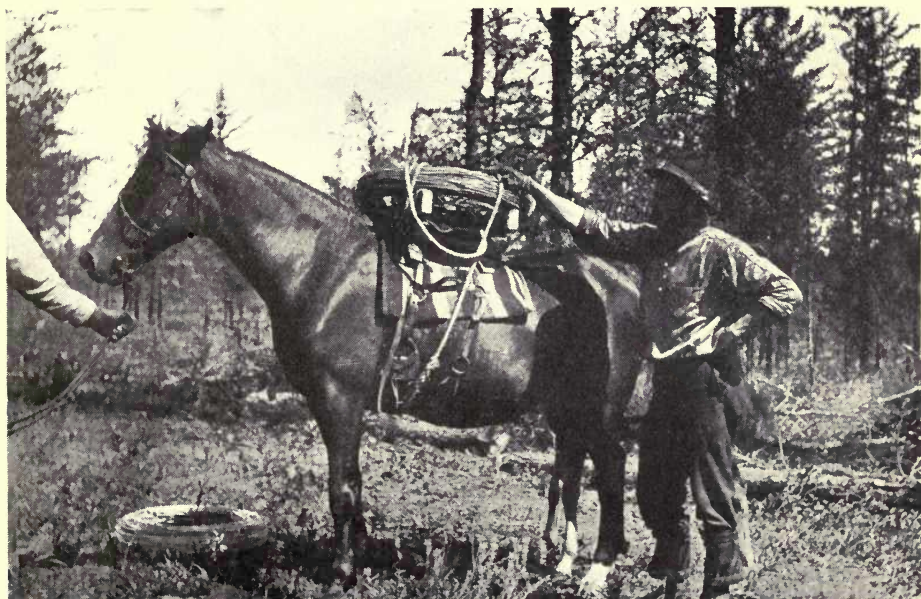

Fig. 6 Mobley wire-cradle as used with one coil

In nearly all the western provinces the use of the public roads as the right of way for telephone lines is controlled by the provincial government. Before any lines are placed on such roads permission must be secured from the proper government department. This must in all cases be taken up through the district inspector.

If it is desired to string wire on poles belonging to a private company written permission should be secured from the inspector before any construction is begun.

### Section 48—Clearing Right of Way

When a pole line is to be constructed, a right of way sufficiently wide to afford reasonable protection against damage to the line from falling trees must be cleared. It is especially necessary that dead or defective trees that lean toward the right of way and threaten to fall across it be removed. The effect of snow on adjacent trees and branches must always be considered, and all that might be borne down across the line should be cut. As a rule pole lines will not be built in the forest if a cleared right of way of greater than 25-ft. width is needed, unless the trees are exceptionally scattered.

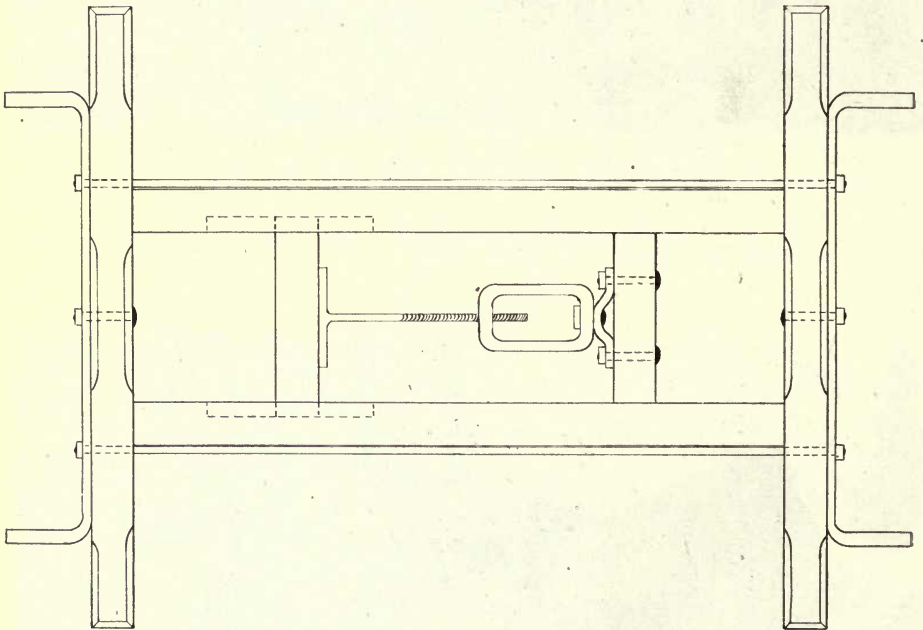

Fig. 7 Mobley wire-cradle.

When pole lines are carried through small timber or reproduction a right of way at least wide enough for a saddle trail should be cleared through any dense underbrush. Small trees directly under the wire, which by their future growth might touch the wire, should be cut down at the outset. Everything, in fact, that might at present or in the near future cause trouble on the line should be cleared before or at the time the wire is strung.

If the line is to be attached to trees it is not advisable or necessary to top the trees to which the split insulators are fastened, except where the line has to cross over a windy canyon or in other places exposed to a strong wind. Under such conditions the trees should either be topped or else poles used, preferably the latter. It is usually only necessary to trim the branches on the insulator side of the tree to a sufficient height for attaching the split insulator. Undergrowth and trees between spans should



be trimmed sufficiently to allow at least a 4-ft. clearance of the line wire. Any dangerous snags or rotten trees in the close vicinity of the line should be cut. A right-of-way clearing for a tree line must usually be at least 8 ft. wide at the height above the ground at which the wire will hang. This is quite different from an 8-ft. clearing on the ground, particularly in long-branching species such as spruce, hemlock, and cedar, but care must be taken to see that sufficient clearing is made before the wire is strung, as otherwise annoying and costly delays result.

In clearing lines through dense underbrush and reproduction, it will be found most satisfactory to scatter the clearing crew singly along the line and have all



Fig. 8 Klondike pack-frame as used for packing wire

material felled into the right of way. The débris resulting from such clearing adds to the fire-danger and should, if practicable, be burned on the right of way before the wire is strung. If not practicable, the brush should be piled off the right of way and left for burning at a time when conditions are favourable.

#### Section 49—Transportation and Distribution of Materials

The wire, brackets, insulators, and other equipment should be conveyed from the railway point or the place of purchase to the proposed line by automobiles, teams, or horses. *Time and money will be saved if construction work is not started until all necessary line equipment has been distributed to its proposed location or to some convenient point.* Wire and other metal should be kept off the ground. All line materials should be distributed along the right of way well in advance of wire-string-

ing crews. Much time will be saved if the  $\frac{1}{2}$ -mile points (or  $\frac{1}{3}$ -mile points) at which coils of wire are to be left are marked in advance of the teams or pack-horses. Use a blaze with a red cross or some other distinctive mark.

It will often be necessary to pack the wire on horses. The maximum load for one horse under best conditions is two  $\frac{1}{3}$ -mile coils of No. 9 wire (weight 104 pounds each) and under poor conditions, one  $\frac{1}{2}$ -mile coil (weight 157 pounds). Single coils may be packed on a horse in several ways, but the following method is suggested: Run a cross-stick lengthwise between the cross-trees on the pack-saddle, tying each end securely. Then split the coil of wire in half and place it over the top of the stick connecting the cross-trees, so that one-half of the coil is on each side of the saddle. Finally, throw a diamond hitch over the whole.

#### 1—MOBLEY WIRE-CRADLE.

A still better method adapted to packing either one or two coils is to use a packing-cradle such as the one designed by Ranger Mobley of the Forestry Branch. This cradle (Fig. 7) consists of a rectangular wooden frame built to fit snugly over the forks of the pack-saddle. The front and rear pieces project a few inches beyond the sides and two pieces of strap-iron with upturned ends are so placed as to hold the side coils in place. In packing two coils, one is hung on each side of the horse on the projecting ends of the cradle and then lashed on with a diamond hitch. When packing one coil it is laid flat on the top of the cradle and lashed in place. This cradle is particularly handy when distributing coils along the line, since it is equally convenient for packing either one or two coils (Figs. 5 and 6). For packing heavy coils of wire on men's backs the Klondike pack-frame shown in Fig. 8 is an unusually effective device.

### Section 50—Organization and Equipment of Construction Crews.

The foreman will be responsible for the work on the line in accordance with the instructions he receives. Whenever possible he should be a forest officer, carefully selected for his experience in telephone construction and in handling men. The size of the crew will depend upon the extent of the work, the qualifications of the individual members, and the time available for completion.

A crew may consist of a foreman, one ground assistant, two linemen, one utility man (swamper and lineman), and, if necessary, a cook. If more speed is desired, one or two additional linemen may be employed, provided arrangement is made to "swamp" the line and distribute materials with sufficient rapidity, to do which may require one or two additional groundmen. Which members of the crew will dig the holes, which distribute the material, and which erect the poles will be determined by local conditions.

Each man employed in digging holes for poles should be provided with:—

One 7-ft. shovel, Western Union pattern.

One medium weight, straight-handled, flat-toed, spoon, Western Union pattern, 7-ft. handle.

One 1-in. by 8-ft. octagon steel digging bar.

In sand or other easy digging a post-hole auger can often be used to advantage.

Each lineman on tree lines should be provided with the following equipment:—

One combination wire-and-sleeve splicing-clamp. This is of the reversible type, one side being used for McIntyre sleeves and the other for Western Union connection.

One pair 8-in. linemen's pliers.

One pair of Eastern climbers, with straps. These run from 14 to 19-in. in length by  $\frac{1}{2}$ -in. intervals.

One belt and safety strap.

One hand-axe.

One bag insulators and tie wires.

A construction crew on pole-line work should also be provided with:—

Two Buffalo grips.

One Haven's steel clamp.

One 3-in. double-pulley block (with one hook).

One 3-in. double-pulley block (with hook and eye).

Thirty-five ft.  $\frac{3}{8}$ -in. sash cord.

## CHAPTER VIII

### POLE-LINE CONSTRUCTION

#### Section 51—Selection of Poles

Poles should be cut as near the proposed line as practicable. The best and most durable timber, such as cedar, tamarack, and Douglas fir, should be used, if it can be obtained at a reasonable cost.

All poles should be cut from live or dead standing trees and should be free from heart-rot or butt-rot, or any other defect which might weaken them. As a means of reducing the cost of poles delivered at the hole it may in some cases be desirable to purchase poles from commercial companies.

Whenever possible poles and braces should be cut in winter to secure better seasoning. They should be peeled as soon as cut and all knots and branches trimmed close. *Unpeeled poles must not be used under any circumstances.* Poles should be reasonably straight and of the dimensions shown in the table below:—

TABLE A—LENGTH AND TOP DIAMETER OF STANDARD POLES

Length of pole ft.	Diameter of top in.	Length of pole ft.	Diameter of top in.
18	6	35	7
22½	6	40	8
25	6	45	10 to 11
30	6 to 7	....	....

When a line will be subjected to severe stresses from high winds or unusual strains, these diameters should be increased by from ½ inch to 1 inch. High poles should be very fine quality. The butts of poles should be cut off square; the tops should be cut slanting on both sides to form a right-angled "roof" as in Fig. 10.

#### Section 52—Skidding and Seasoning

It is sometimes possible to collect a number of poles or braces at one point as they are cut, and later to distribute them along the line without undue expense. In such cases the poles should be completely barked and piled in tiers, with a space of at least 6 inches between poles in the same tier and between tiers. The bottom tier should be of sufficient height from the ground to allow of the free circulation of air under the poles, which should be seasoned for at least two or three months. Seasoned poles are lighter and therefore easier to handle. Poles should not be held in storage too long as they are liable to start to decay.

When it is not feasible to collect poles or braces at one point, the individual pieces should be peeled and raised off the ground or leaned against trees or rocks in an open position to season. Sound dead timber need not be seasoned.

It is particularly necessary, when poles are to be treated with any form of preservative, that they be well seasoned and, so far as possible, be accumulated at a very few places along the line. In most cases it will be found desirable to prepare such poles a season before line construction is contemplated.

#### Section 53—Preservative Treatment

If durable woods cannot be obtained at a reasonable cost it may be necessary to give the poles preservative treatment. Before doing this, however, the district inspector should be consulted. The poles of branch lines less than 3 miles long need not be treated in any case, unless the branch is constructed at the same time as a main line of treated poles.

The experience of the Forestry Branch with untreated spruce and poplar poles in the Prairie Provinces has shown that they have a length of life of only 3 to 5 years. Eastern tamarack poles are somewhat better, lasting from 6 to 9 years. Experiments have just been begun with lodgepole pine on Dominion reserves, but experience with this species in the United States has shown that its dependable length of life, untreated, is not over 7 years. Jack pine will, probably, be about the same. It is considered that permanent trunk lines on the forest reserves should be built to last without pole renewals on a large scale for at least 15 years. This may be accomplished by using either well-seasoned, untreated cedar poles or well-treated native poles.

Special instructions with regard to the use of untreated and treated poles on Forestry Branch lines will be issued by the Director of Forestry. There are only two methods of pole preservation that may be applied with a reasonable degree of success under the conditions usually encountered on forest protection lines. These are the "open-tank" method and the "brush method." The latter gives only a very slight increase in durability and is only desirable under certain very special circumstances. The former is the most successful method yet devised for the type of line employed by the Forestry Branch. Treatment is applied only to the portion of the pole placed in the ground. In some cases it may be preferable to treat 8 ft. or 9 ft. stubs and set poles as explained in Section 91. Before any treatment is applied all adhering bark, including the inner fibrous bark, should be removed with a draw-knife from the portion of the pole to be treated.

As the details of the treating apparatus and the methods of treatment have not yet been standardized for Forestry Branch lines, only a brief reference to these methods can be made at present and complete instructions will later be issued in the form of a supplement to this manual. In the meantime, pole treatment will only be undertaken in accordance with specific instructions issued by the district inspectors.

### 1—OPEN-TANK METHOD

Wherever practicable, this method of treatment is the best that can be employed. Creosote, heated to a temperature not to exceed 200° F., is the preservative used. (See "Preservative Treatment of Poles," United States Forest Service Bulletin No. 84, and "Preservative Treatment of Fence-posts," Forestry Branch Circular No. 6.)

### 2—BRUSH TREATMENT

This process requires less equipment than any other, but the results are not nearly so good as the open-tank method. Brush treatment even when well done cannot be depended on to add more than 2 or 3 years to the life of a pole. A brief description follows: Hot creosote or hot carbolineum is applied to the poles with iron-bound brushes for a space of about 1 ft. above the ground line and 2 ft. below it, thus forming a band 3 ft. wide. All seasoning checks and knot holes should be carefully filled and the preservative applied as freely as possible without waste, putting on all that the poles will absorb. After an interval of at least 24 hours the poles should be treated with a second coat applied in the same manner.

In hot, dry weather the creosote should be heated to a temperature of from 120° to 150° F. and in cold weather to 180° F. These temperatures, however, should not be exceeded. In heating the creosote the utmost precaution should be taken to prevent accidents. If the heating vessel is allowed to boil over or if creosote is spilled and allowed to burn on the outside of the vessel, the contents are pretty sure to ignite and burn fiercely. If creosote becomes mixed with water the mixture boils violently several degrees below the boiling point of the latter.

The preservative should never be applied to green timber nor when the surface of the pole is wet from rain, snow or frost, or is frozen.

The tops of the poles and the places where the brackets and braces are to be attached should also be treated with two coats of hot creosote, and the same is true of the butts of braces and the slanting top which is to rest against the pole.

A convenient outfit for brush treatment consists of a 5-gal. or 10-gal. can or iron pot, a 3-gal. pail,  $\frac{1}{2}$ -gal. dipper, a 4-in. or 5-in. wire-bound brush, and a thermometer. A small-sized, galvanized-iron wash-tub has been used with success in some places as a vessel in which to heat creosote oil.

### Section 54—Length of Poles

The standard pole is 22 $\frac{1}{2}$  ft. long, and this dimension will be used in all but special cases. When for any reason non-durable poles must be used without preservative treatment, the standard length will be 25 ft. and no shorter poles may be used without specific authority from the district inspector.

Poles shorter than 22 $\frac{1}{2}$  ft. may be used, with the approval of the district inspector, provided the standard length is not available, or, for some reason, is undesirable. When a line crosses solid rock, and when it would be cheaper, the use of 2-in. or 2 $\frac{1}{2}$ -in. wrought-iron pipes for short-length poles should be considered, notwithstanding their liability to rust. Such poles may be fitted into drilled holes, thereby making blasting unnecessary. There are several forms of commercial brackets and pins which, by the use of a little ingenuity, may be set into the top of these poles or fastened to the side by carriage bolts.

Poles longer than 22 $\frac{1}{2}$  ft. may be used:—

(1) Where the spacing of the poles is such that the required sag in the line would bring the wire too close to the ground.

(2) Where the underbrush exceeds 10 ft. in height. Use poles that will keep the lowest wire at least 4 ft. above the highest brush at the middle of the span.

(3) Where snow is likely to drift to depths exceeding 10 ft. use poles that will keep the lowest wire at least 2 ft. above the maximum height of the drift at the middle of the span.

(4) Where it is necessary to grade the line to overcome abrupt changes in level. For example there should not be an abrupt change from a 22 $\frac{1}{2}$ -ft. pole to a 45-ft. pole. Instead after a 22 $\frac{1}{2}$ -ft. pole place a 30-ft. pole and then complete the change by using poles of gradually increasing length until the 45-ft. length is reached.

(5) Where the line crosses wagon roads or railways. Use poles that will allow a clearance between the lowest wire and the road-bed of at least 16 ft. above a road and 25 ft. above a railway, measured from the middle or highest point of the road or track. Greater heights must be maintained if required by provincial laws. (See "Crossings," Section 66.)

(6) Where necessary to cross over instead of under other poles. (See "Crossings," Section 66.)

(7) At the ends of long spans (more than 500 ft.) across rivers and canyons. Special poles or construction, approved by the district inspector, should be used.

Poles shorter than 22 $\frac{1}{2}$  ft. may be used:—

(1) On short lines where the standard length pole cannot be readily secured.

(2) When stubs of durable species or treated with creosote are employed.

Before using short poles the approval of the district inspector must be secured. No pole less than 18 ft. long or 5 in. in diameter at the top may be employed.

### Section 55—Erection of Poles

#### 1—DISTRIBUTION OF POLES

In distributing poles along a line the heaviest ones should be selected for use on curves, at corners, at the ends of long spans, and at terminals.

## 2—SPACING

On straight sections poles should be set 176 ft. apart, which is equivalent to 30 poles per mile. For a grounded line, carried on poles, the distance apart, under favourable conditions, may be 200 ft., or about 26 poles to the mile. Changes in the direction of a line should be made gradually by spreading the curve over as many poles as possible, raking each pole outward to offset the strain. On curves and corners where the pull is from 10 to 30 ft., the pole spacing should be reduced to 100 ft. Where the pull is more than 30 ft., the turn will be made on two poles, approximately 100 ft. apart, with equal spacings in the adjacent spans on either side. At right-angled corners the length of the section on either side next to the corner pole should not exceed 100 ft.

Where it is necessary to make a span of from 200 to 300 ft., the adjacent sections should be 100 ft. in length. Spans of from 300 to 500 ft. should have two sections of 100 ft. on each end. For spans of more than 500 ft. special construction is required.

Where the line crosses solid rock, the length of spans may be increased up to 300 ft. to avoid the expense of blasting holes. When it is necessary to blast many holes, special construction may be desirable, and the matter should be taken up with the district inspector.

Abrupt changes in the level of the wire should be avoided. Poles should be set on either side of a high or low point, using long poles, if necessary, to obtain the desired clearance in the span. In crossing a ridge or ravine, for example, it is better to space the poles so that one is set on each side of the ridge or ravine rather than to set a pole on the crest or in the bottom.

## 3—DIGGING HOLES

On straight sections holes should be vertical, uniform in size from top to bottom, and at least 6 inches larger in diameter than the butt of the pole. This will permit the earth to be evenly tamped around the pole for the total depth of the hole. In general, the depth of holes for various sizes of poles should be that shown in the following table. On curves or in soft soils, however, holes should be at least 6 inches deeper than the figures given.

TABLE B—SIZE OF HOLE FOR DIFFERENT LENGTHS OF POLE

Over-all length of pole	Depth of hole		Over-all length of pole	Depth of hole	
	In earth	In rock		In earth	In rock
	ft.	ft.	ft.	ft.	ft.
18.....	4	3	35.....	6	4½
22½.....	4	3	40.....	6½	5
25.....	4½	3½	45.....	6½	5
30.....	5	4			

On a hillside the depth of a hole should be measured from the lowest side of the opening. Where the hillside is so soft that the pole may possibly "kick out," the depth of the hole should be determined by the foreman.

Where it is not possible to dig the required depth, the hole should be blasted. If this is not feasible, the pole should be securely braced or guyed.

## 4—ATTACHMENTS TO POLES

Standard brackets with insulators and all other equipment which is to be attached to the pole should be put in place before the pole is erected.

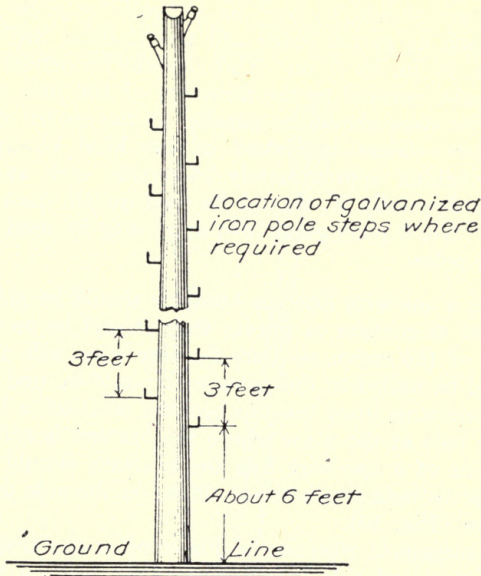

Fig. 9 Pole-steps

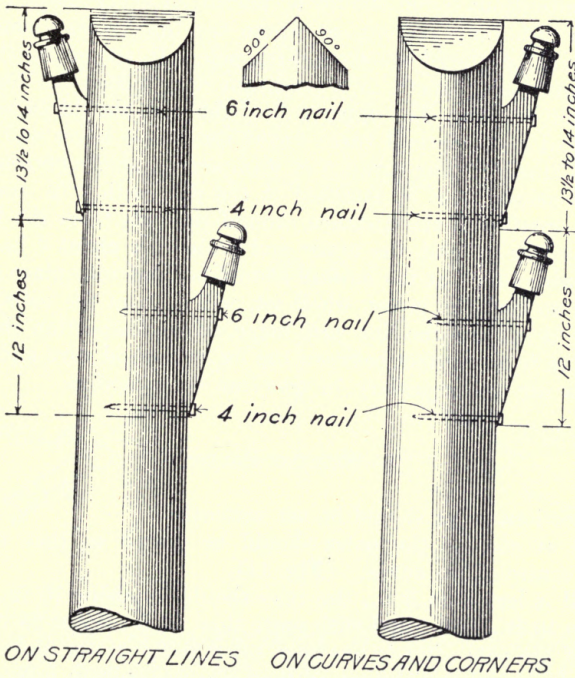

Fig. 10 Location of brackets on pole

(a) *Pole-steps*.—Steps should be used on all poles over 35 ft. high or to which telephone apparatus, such as switch-boxes and test-stations, are attached. The steps are of galvanized iron,  $\frac{1}{8}$  in. by 9 in. They should be driven alternately into the opposite sides of the pole, parallel to the direction of the line, and spaced 18 in. on centres. The line of the steps should be parallel to the centre of the poles.

(b) *Glass insulators*.—Glass insulators of the kind known as “regular pony long-distance type”, weighing approximately 14 ounces each and conforming to the specifications given in Appendix E, should be used on all lines built of No. 9 wire when strung on poles. No. 9 pony glass insulators may be used for all lines built of No. 12 wire strung on poles.

(c) *Brackets*.—On a one-wire line the brackets should be placed on the same side of all poles, except that at corners or curves they should be on the side of the poles away from the centre of the curve, so that the line wire will pull them against the poles. Brackets should be nailed to the poles with one 6-in. and one 4-in. galvanized-iron wire nail. For one-wire lines the top bracket position will be used. It is not necessary to shave the pole at the place where the bracket is attached.

On straight sections of a two-wire line the brackets should be on opposite sides of the poles, but on curves both brackets should be on the side of the pole away from the centre of the curve (Fig. 10).

As an additional safeguard whenever a line crosses the tracks of a railway, two brackets with insulators placed side by side should be used on the first pole on each side of the track. Where a line is attached to a large pole at a sharp corner two brackets slightly separated will be used, in order to keep the line wire clear from the pole.

(d) *Lightning-rods*.—Lightning-rods should be placed on poles before they are set. In ordinary situations a rod should be placed on every tenth pole.

In exposed, mountainous regions, or where the line crosses mountain ranges or divides, a rod should be placed on every fifth pole. It should be the same kind of wire as the line and long enough to reach from 6 in. above the top of the pole to about 3 ft. below the bottom. The upper end of the wire should be bent back about 3 in. from the end and given several turns about itself; the lower end should be made into a small coil of three or four turns, 5 or 6 in. across, at the bottom of (not round) the pole. The rod should then be attached to the pole with 2 in. staples at intervals of 3 ft. at a point one-fourth the distance around the pole from the bracket, running in a straight line to the ground, the upper end projecting about 3 in. above the ridge of the pole. The wire coiled at the bottom should be bent into place or stapled at the bottom of the pole so that the latter, when set, will rest on the coils.

After the pole is set and the line wire attached, an inspection should be made to make sure that there is no contact between the lightning-rod wire and the line wire.

Lightning-rods are not necessary in tree-line construction.

## 5—SETTING POLES

On straight sections poles should be set vertically.

On curves or at corners the poles should be placed so that they will incline outward from the centre of the curve. (Fig. 11).

When the pull is less than 5 ft., the rake should be about 10 in. (Fig. 11); with a pull of from 5 to 10 ft. 15 in.; and with more than 10 ft., about 25 in. These figures apply to the top of the pole after it has been set and before the line wire is attached. Warped or crooked poles should be set so that the crookedness will offset the pull of the line wire at the ends of long spans or on curves or corners. No attention need be paid to the possibility of the line wire changing the amount of rake. These specifications are approximate and may be exceeded without harm. Rake is sometimes necessary even though the pole is braced or guyed.



Poles should be set with the roof ridges at right angles to the line wire, except when cross-arms are used or when it is probable that they will later be used, in which case the ridge will parallel the line. The bracket should be exactly at right angles to the line and in the proper position to prevent the line wire from touching the pole.

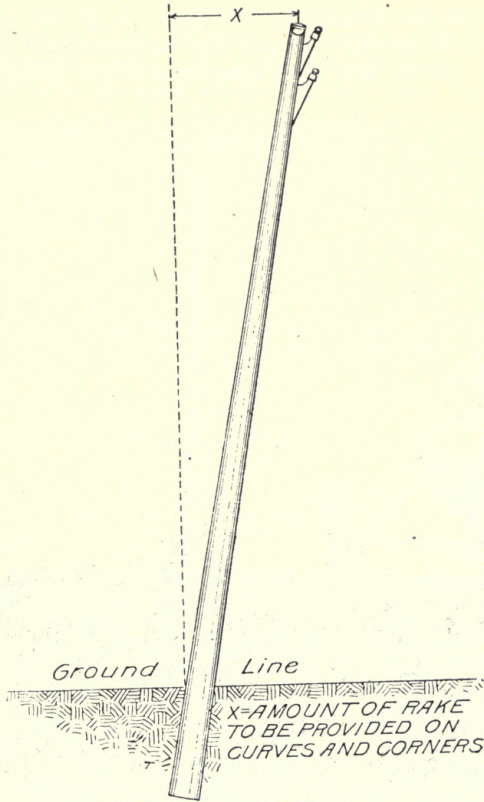
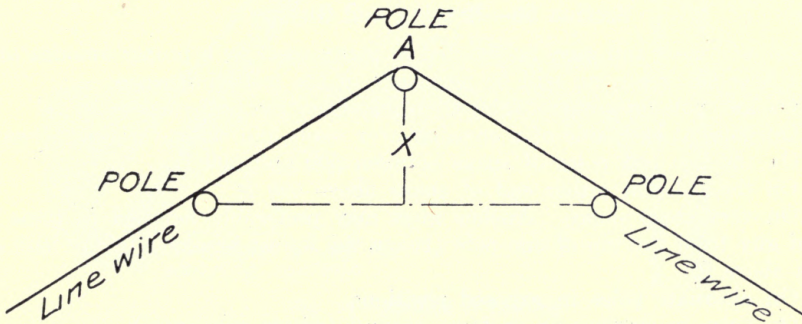

Fig. 11 Definition of rake



THE PULL ON CORNER POLE A EQUALS DIMENSION X MEASURED ON GROUND LINE USE SAME METHOD FOR DETERMINING PULL ON EACH POLE IN A CURVE

Fig. 12 Definition of pull

## 6—FILLING AND TAMPING

In setting a pole it should be "trued" and held in position with pike-poles until firm, the dirt being filled in evenly around it and thoroughly tamped as the filling progresses (Fig. 13). The coarse soil or gravel should be put in last. The filling can be done by one man, and the tamping by two men. After the pole is set and the hole filled, about 6 in. of earth should be closely packed around the pole above the ground. Poles set in solid rock should have rock fragments firmly wedged in around them.

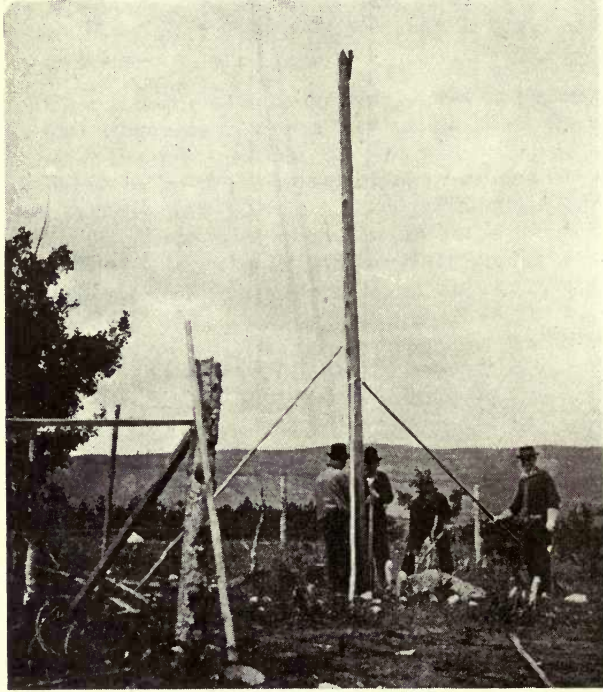

Fig. 13 Setting a pole

## Section 56—Bracing and Guying

The use of braces and guys is obviated in many cases by a proper amount of rake, but either bracing or guying will be necessary in the following cases:—

- (1) On any pole on a curve or at a corner where the pull exceeds 30 ft.
- (2) On poles at each side of a crossing over roads and railway rights of way.
- (3) On the two end poles of spans between 300 and 500 ft.
- (4) On the poles at either end of spans above 500 ft.
- (5) On very steep slopes. Anchor guys may preferably be used in these cases, or a head guy from the top of one pole (below the lowest bracket) to the base of the pole next above it.
- (6) On alternate poles in exposed positions.
- (7) On poles in swamps or on loose ground (where necessary.)
- (8) On poles on both ends of high-tension transmission line crossings.
- (9) On the first and last poles of a line.

## 1—BRACES

Braces (Fig. 14) should be at least 8 in. in diameter at the butt end, cut slanting at the top to fit close to the pole but the pole itself should not be cut. They should

be set at least  $2\frac{1}{2}$  ft. in the ground— $3\frac{1}{2}$  ft. would be better if too much difficulty is not encountered in digging. The distance between the brace and the pole, as measured on the ground, should be not less than one-half of the height of the pole above ground. The bottom end of the brace should rest on a flat stone or piece of log or plank. After boring a  $\frac{5}{8}$ -in. hole through both the brace and the pole just above the point where the bottom edge of the brace touches the latter, the brace should be bolted tightly to the pole with a  $\frac{5}{8}$ -in. galvanized-iron bolt, using galvanized-iron washer,  $2\frac{1}{4}$ -in. square and  $\frac{3}{8}$ -in. thick under both the head of the bolt and under the nut.

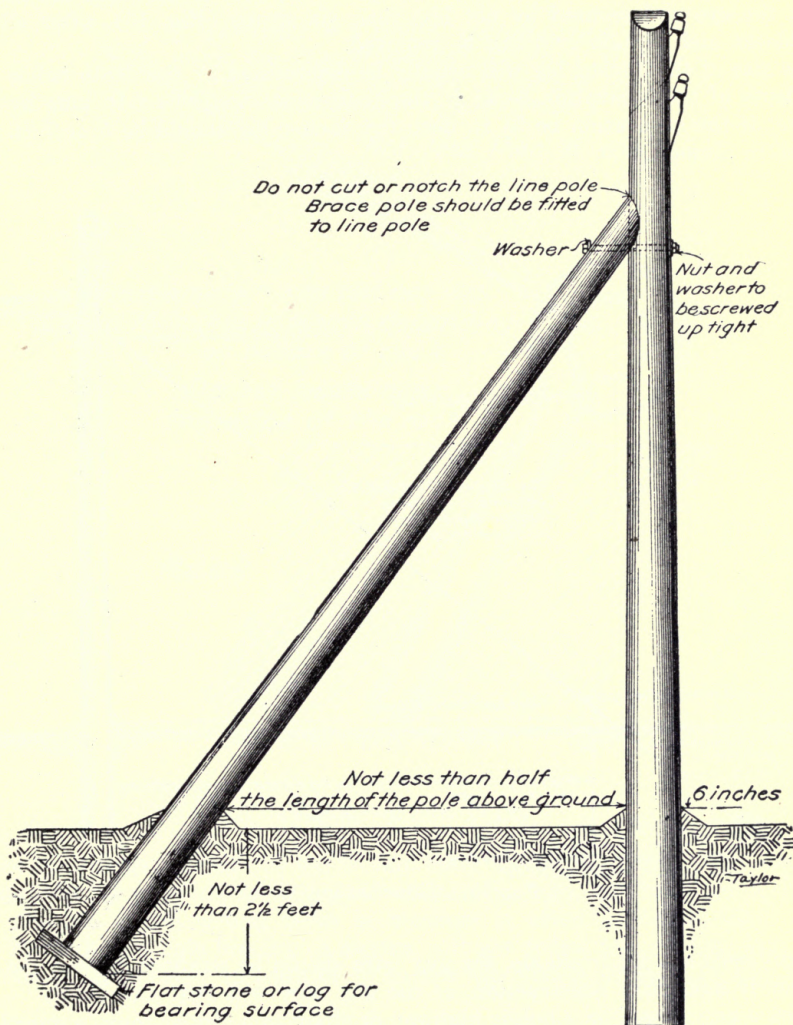

Fig. 14 Method of bracing

## 2—Guys

(a) *Anchor Guys*.—Anchor guys (Fig. 15) should be made of two pieces of line wire (No. 9 B.W.G.) twisted together, and, if possible, of sufficient length to reach from the bottom of the lowest bracket to a point on the ground at a distance from the bottom of the pole equal to the height of the bracket above the ground, but under no

condition less than 8 ft., with enough additional length to allow one end to be passed through the eye of a standard half-inch, galvanized-iron guy rod, the other to be wrapped twice around the pole, and both secured.

When a guy has been prepared, one end should be wrapped around the pole twice and stapled, the loose end being secured by wrapping not less than six times around the wire, using a pair of connectors or pliers. An anchor log should then be placed in the ground with a guy rod passing through it, the eye of the rod projecting above the ground. One of a pair of pulley blocks should then be hooked into the eye and the other fastened to a Buffalo grip or a medium-sized Haven clamp attached to the guy wire. The latter should then be pulled to the required tension and the end looped through the eye and secured by not less than six wraps (Fig. 15), after which the pulley blocks and Buffalo grip can be removed.

The size of the anchor log will usually be determined by the depth below ground. If the depth of the excavation be  $4\frac{1}{2}$  ft. the anchor log should be 4 ft. long by 5 in. in diameter; if the excavation be  $3\frac{1}{2}$  ft. deep the anchor log should be 5 or 7 ft. long by 8 or 6 in. in diameter.

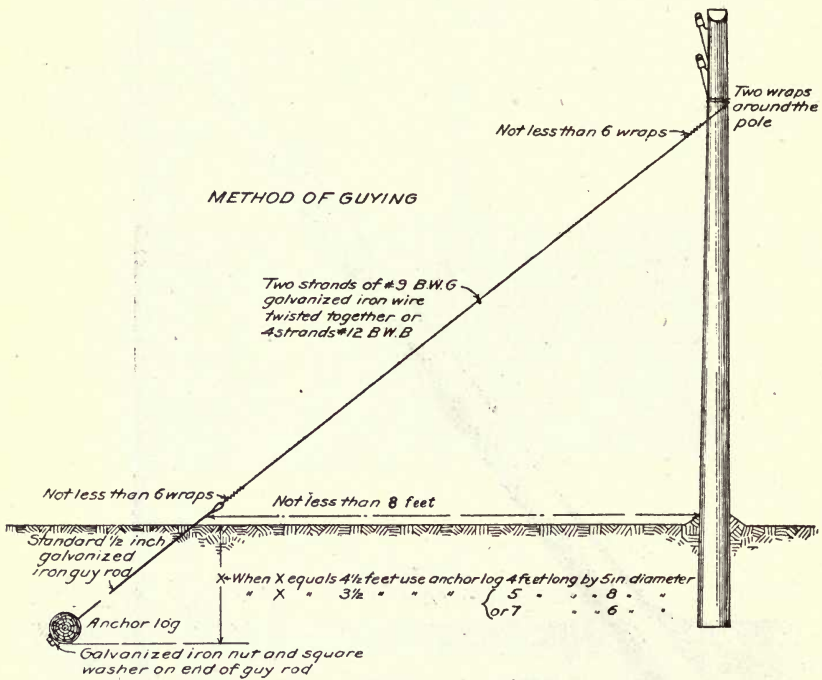

Fig. 15 Method of guying

If guy rods are not available, the guy wire should be wrapped around the anchor log. This is temporary construction, as the guy wire will rust and break.

When a guy is used on a public highway or street in a city or town, a guard should be used to make it readily visible. For this purpose it may be boxed up to a height of 6 ft. above the ground, or a sapling about 3 in. in diameter may be wired to it. This protection is also desirable where guy wires are necessary on open meadows, etc., frequented by men or stock.

(b) *Tree guys.*—If there is a live tree of large diameter nearby, the guy wire may be fastened to it instead of to a buried log. Hardwood slats should be used between the guy wire and the tree to prevent injury to the latter, as in Fig 33.

(c) *Rock guys.*—A home-made iron eye-bolt 1 inch in diameter and not less than 18 in. long may be used for anchoring a guy wire in rock. The angle formed by the guy wire and the shank of the bolt should not be more than a right angle (Fig. 16). The bolt should not be near the edge of the rock or ledge.

(d) *Guying across roads.*—If a guy wire, as ordinarily placed, would interfere with traffic on a road, a stub should be used (Fig. 17) to provide proper clearance. The stub should be stayed with the standard guy rod and anchor log; or if this is not possible, braced with anchor logs underground, as shown for the pole in Fig. 18.

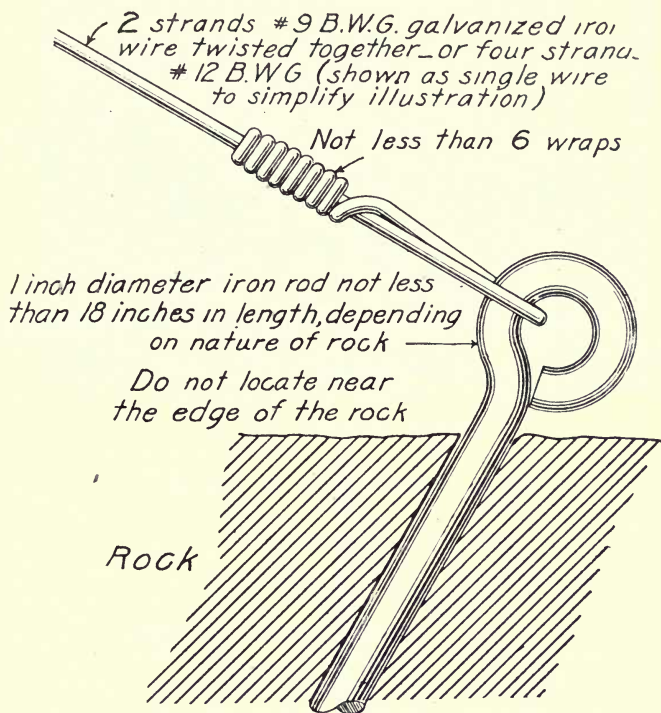

Fig. 16 Rock guy bolt

### 3—SELF-SUPPORTING POLES

Where conditions prevent the use of any other method of guying, and especially in swampy soil, the poles should be braced with anchor logs, as illustrated in Fig. 15.

The problem of supporting poles in muskegs is often a difficult one. Where ordinary methods of single bracing or guying will not suffice two or even four braces may sometimes be necessary in addition to anchor logs placed as shown in Fig. 18.

### 4—TRIPODS

The difficulties encountered in supporting poles in muskegs are often increased by unusual soil conditions which make the digging of holes very costly. Some success has been met in the employment of tripods instead of poles in crossing such muskegs. These tripods are constructed of peeled poles having a butt diameter of 5 in., top diameter of not less than 3 in., and a length of 22 to 24 ft. Lodgepole pine is the most suitable material, but spruce, tamarack, or jack pine may be used. Each tripod con-

sists of two 22-ft. and one 24-ft. pole and these poles are wired together through holes bored 21 ft. from the butt end so that they may be raised or lowered at will. The longer pole thus projects 2 ft. beyond the other two and from it the line wire is suspended in a split tree insulator. The butts of the poles are not set in holes

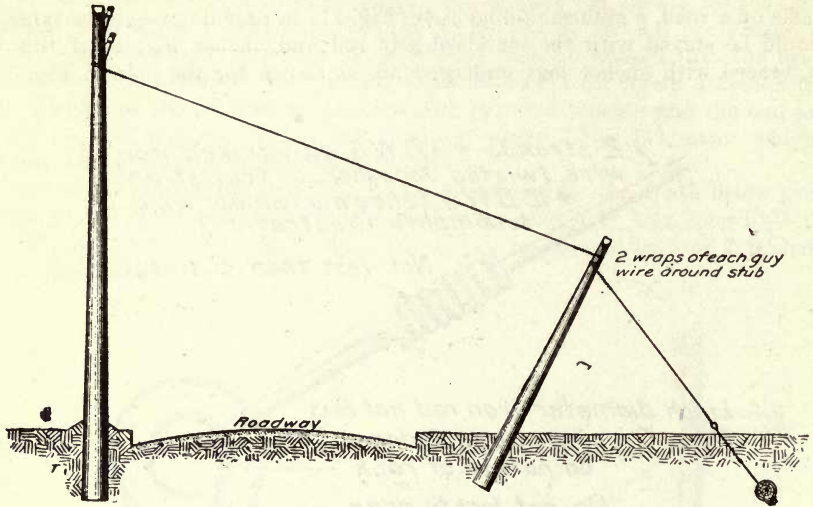
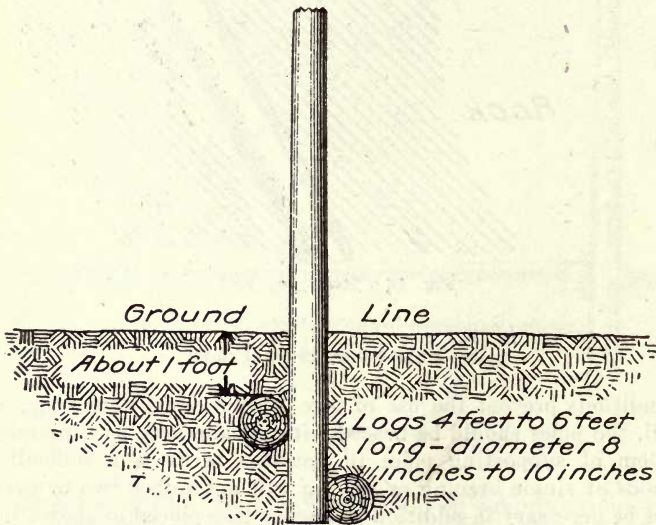

Fig. 17 Method of using guy stub



*This method of ground bracing may be used for poles in swampy soil. Also for poles or guy stubs when not possible to anchor them.*

Fig. 18 Method of ground bracing

but are set directly on the ground surface, and to prevent them sinking into soft soil a 5-ft. cross-log about 4 in. in diameter may be spiked or wired to the lower end of each leg.



Fig. 19 Tripod line supports

### Section 57—Line Construction

#### 1—LINE MATERIALS

Iron wire is divided into three grades: Extra Best Best, Best Best, and Steel. The Extra Best Best (E.B.B.) wire possesses the highest conductivity, but the lowest tensile strength. It is designed for use on the main lines of telegraph companies, and by telephone companies where a wire of high conductivity combined with strength and toughness is required. The steel wire is made from a special grade of material. It is the lowest in conductivity but highest in tensile strength. The Best Best (B.B.) wire, which possesses intermediate qualities, is more generally used than the others on medium distance circuits by telephone companies and for railway work.

The following table gives the physical characteristics of these three grades of wire:—

TABLE C—PROPERTIES OF DOUBLE GALVANIZED TELEGRAPH AND TELEPHONE WIRE<sup>1</sup>

No. B.W.G. Wire	Diameter in inches	Weight in pounds per mile	Put up in bundles of—	Approximate breaking strength in pounds			Average resistance in ohms at 68° F.		
				E. B. B.	B. B.	Steel	E. B. B.	B. B.	Steel
4.....	0.238	811	Mile	2,433	2,676	3,000	5.98	7.15	8.32
6.....	.203	590	$\frac{1}{4}$	1,770	1,947	2,183	8.14	9.83	11.44
8.....	.165	390	$\frac{1}{2}$	1,170	1,287	1,443	12.43	14.87	17.31
9.....	.148	314	$\frac{3}{4}$	942	1,036	1,162	15.44	18.47	21.62
10.....	.134	258	1	774	851	955	18.80	22.48	26.16
11.....	.120	206	$1\frac{1}{4}$	618	680	762	23.54	28.15	32.76
12.....	.109	170	$1\frac{1}{2}$	510	561	629	28.53	34.12	39.70
14.....	.083	99	$1\frac{3}{4}$	297	327	366	49.00	58.58	68.18

<sup>1</sup> Summary of tests by John A. Roebling's Sons Co.

All iron wire should be well galvanized to protect it from the corrosive action of the weather. (For specifications see Appendix E.) Its life is 15 to 30 years and it has little or no wrecking value when removed.

Hard-drawn copper wire possesses great conductivity and high tensile strength and does not deteriorate when exposed to the weather. It is therefore well adapted for telephone lines. More difficulty is encountered, however, in obtaining good electrical joints when splicing copper wire than when splicing iron wire. Copper wire is of particular value where unusual construction is required, such as on very important trunk lines over 125 miles in length, on metallic circuits, etc. It lasts almost indefinitely and has a wrecking value equal to 80 per cent of its first cost.

## 2—STANDARD CONSTRUCTION

A one-wire line (grounded circuit) of No. 9 B.W.G., Best Best galvanized-iron wire will be the standard construction on the forest reserves. No other method should be used unless the permission of the district inspector is first obtained. If the line is located outside of the reserve where there are no trees, No. 12 B.W.G. galvanized wire may be used, provided the length is short. Metallic circuit lines are used only where there is outside interference, such as cross-talk, induction, or trouble from power-transmission lines. It is not possible to talk any farther over a metallic circuit line than over a grounded circuit line provided the grounds of the latter are made properly. Where the length of a line exceeds 125 miles it will probably be necessary to use copper wire. This cannot be used with swinging insulators and will not be employed except on a strictly pole line. Where necessary, a two-wire line (metallic circuit) of copper wire may be used.

For spans up to 500 ft. the No. 9 galvanized-iron wire should be used, except when the circuit is of hard-drawn copper wire. For longer spans steel wire or other forms of special construction will be necessary. No. 12 New British Standard gauge (N.B.S.G.) hard-drawn copper wire should not be used on spans longer than 300 ft., nor No. 14 N.B.S.G. hard-drawn copper wire on spans longer than 200 ft. If the circuit is of No. 12 N.B.S.G. hard-drawn copper wire and it is necessary to make spans longer than 300 ft., No. 8 N.B.S.G. hard-drawn copper wire should be used for the spans from 301 to 500 ft. If the circuit is of No. 14 N.B.S.G. hard-drawn copper wire and it is necessary to make spans longer than 200 ft., No. 12 N.B.S.G. hard-drawn copper wire should be used on spans from 201 to 300 ft.

## 3—CAUTIONS

Great caution must be used during lightning storms. *While lightning is being discharged in the vicinity of the work, and as long as there is any danger from this source, no line wire or any wire electrically connected should be handled or touched.*

## 4—STRINGING WIRE

There are several satisfactory methods of removing the wire from the reel, and which one to use will be determined by the conditions in each particular case. A man familiar with the location of the line and with the transpositions should be in charge of the unreeling of the wire. In paying out the wire care should be taken to place it on the proper side of poles or trees, in order to avoid cutting it. Splices should be as few in number as possible.

When the conditions permit the use of a wagon, the reel may be placed in the back and the wire laid upon the brackets as fast as the wagon proceeds.

Another method is to have the wire pulled out by a horse, either with a rope that can be released instantly, between the ends of the wire and the traces of the horse, or by tying the end of the wire to the horn of the saddle, with a man watching the reel. Where the line is very crooked the reel should be placed at less than one-half mile from the starting point.



Instead of using a wagon or horse, the wire may be unreeled by three men, one of whom should be stationed at the reel to see that the wire is not paid out too fast and to signal in case it becomes kinked or tangled.

Another method in forest reserve work is for two men to carry the reel, paying out the wire as they go. This method only should be used in stringing copper wire, as this wire should never be dragged on the ground.

Wire should not be paid out from a coil held by one man, since it comes off badly twisted and is likely to kink. Always use a reel.

Hard-drawn copper wire must be handled much more carefully than galvanized-iron wire. The coil should not be thrown from a wagon to the ground. Before commencing to unreel it, the first 15 or 20 loops of the coil should be carefully lifted by hand to guarantee that there are no "crossovers." Hard-drawn copper wire should never be dragged on the ground while being strung. If a wagon cannot be used to carry the reel, it should be carried by several men.

Care must be exercised when starting to unreel a coil to see that the outer end of the wire is taken off. This end is generally indicated by having attached to it a small tin tag on which the weight of the coil is stamped. The pay-out reel handled by the supply houses is of hardwood bound with iron straps. Its weight often precludes its use on lines following trails and through timber. A home-made reel is much lighter and less expensive. This consists of two parts, a support and the reel proper (Fig. 20).

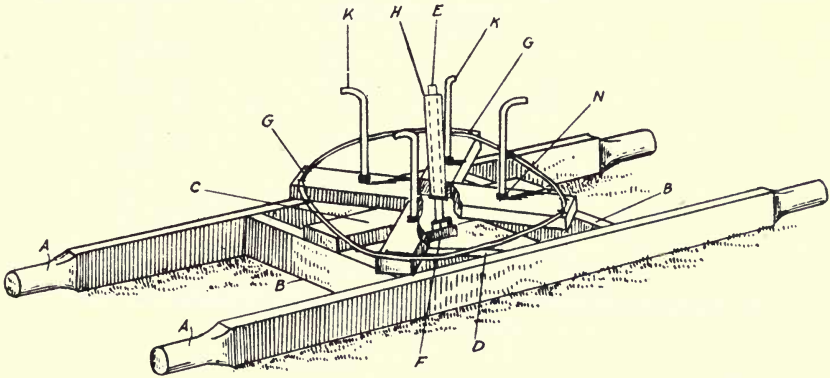

Fig. 20 Home-made reel

The support is made of two 2-by-4-in. pieces AA, each 5 ft. long and held 2 ft. apart by two cross-pieces BB of 2-by-4-in. stuff, nailed between and 1 ft. each side of the centre of the long pieces. Midway between the long pieces and fastened to the cross-pieces is a 2-by-6-in. stick C. To secure greater rigidity, a 2-by-4-in. stick D is mitred to fit from the centre of one side to the centre of one of the cross-pieces.

At the centre of stick C a block 6 in. square and 1 in. thick is attached, and through its centre and through stick C a  $\frac{3}{4}$ -in. hole is bored. Around this hole on top of the block a 2-in. iron washer is attached with screws, the heads of which are well countersunk. A bolt E, 14 in. by  $\frac{3}{4}$  in. with square head is then inserted in the hole in C from below, and held in place by countersinking the square head on the underside of C and nailing a small block F over it. The reel is made of two pieces of 2-by-4-in. stuff, preferably Douglas fir or some other strong wood, GG 2 ft. 9 in. long and mortised in the middle to form a cross. After these have been fitted together a 1-in. hole is bored through the centre and a piece of 1-in. iron pipe H, 9 in. long and threaded for 2 in. at the end is screwed firmly into this hole. On the underside around the hole a 2-in. iron washer is fastened to act as a bearing. Nine inches from the centre on each arm G a  $\frac{3}{8}$ -in. standard K, 18 in. long and shaped as illustrated, is

set upright and held in place by two nuts N, one on each side of the arm. Care must be taken to see that these standards do not project below the arms more than the thickness of the lower nut. The portion threaded should equal the thickness of the arm plus the thickness of the two nuts. The cost of the whole apparatus is so small that after the iron fittings are removed the rest may be discarded, if necessary, when the work is completed.

No more wire should be strung out than can be put up and tied in during one day. Special care should be taken not to allow the wire to lie across trails or roads where it might be run over by vehicles or trampled by animals. Kinks or nicks made in this way may weaken the wire sufficiently to cause it to break as soon as a little strain is put upon it, or when it contracts in cold weather. All kinks should be straightened before the wire is stretched. If the kinks or nicks are bad they should be cut out and a splice made.

#### 5—TRANSPOSING LINES

By transposition is meant changing the location of a wire from one side of the pole to the other (Fig. 21). This is done to overcome the effects of outside interference existing in lines which are close to or parallel with high-tension transmission lines, and wires which are on poles carrying other wires.

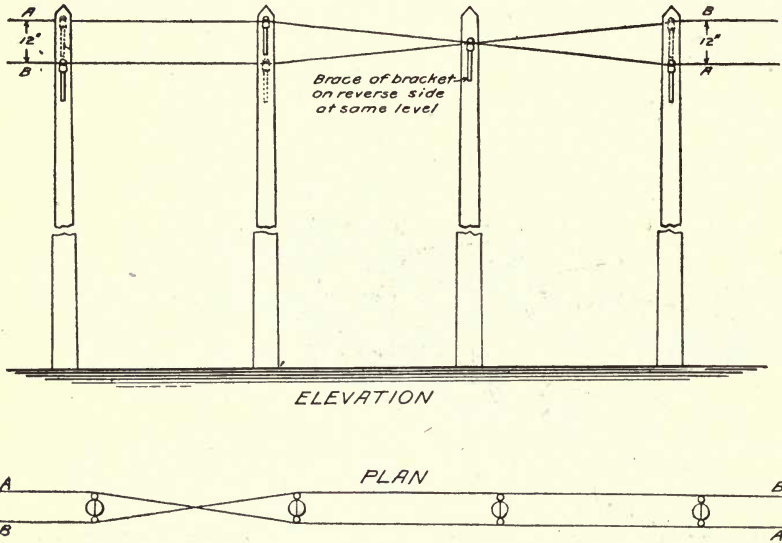

Fig. 21 Transposition of wires, metallic circuit

When building a metallic circuit, the wires should be transposed once every mile. Where the line is exposed to induction, cross-talk, power wires or electric-light wires, the line wires should be transposed at least every tenth pole. In transposing telephone lines, the wire on the left should always cross over, never under, the wire on the right, and without touching it. On a bracket line the transposition can be made very easily by changing the location of the brackets on the pole, as shown by the upper diagram in Fig. 21. When a cross-arm is used, transpositions can best be made by using a standard two-piece transposition insulator. Transpositions should be arranged for at the time the wire is unreeled, the left-hand wire crossing over on top of the right at the point where the line is to be transposed.

#### 6—SAG ALLOWANCE

The stresses in the telephone wire undergo changes with variations in temperature, thus making it necessary to provide for the extreme variations in wire length in each

span. The sag in the wire at the time it is made fast to the brackets should correspond to the temperature at that time.

TABLE D—SAG OF A No. 9 B. W. G. GALVANIZED-IRON WIRE IN A POLE LINE

Length of span in ft.	Sag at temperature indicated in degrees F.													
	+100°		+80°		+60°		+30°		+10°		-10°		-30°	
	ft.	in.	ft.	in.	ft.	in.	ft.	in.	ft.	in.	ft.	in.	ft.	in.
75.....		4½		3		2½		2		1½		1½		1
100.....		7		5½		4½		3½		3		2½		2
115.....		9		7		5½		4		3½		3		2½
130.....		11		8½		7		5½		4½		4		3½
150.....	1	2		11½		9		7		6		5		4½
176.....	1	6		1 3		1 0		9½		8		7		6
200.....	1	10½		1 7		1 4		1 0		10½		9		8
260.....	3	3½		2 10		2 5½		1 11		1 8		1 5½		1 3
300.....	4	7		4 1		3 6½		2 9		2 5½		2 1½		1 10
350.....	6	6		5 6		4 11		3 10		3 5		3 0		2 7
400.....	8	0		7 0		6 6		5 0		4 6½		4 ½		3 7
450.....	10	0		9 0		8 0		6 6		6 0		5 6		5 0
500.....	12	6		11 0		9 6		8 0		7 6		7 0		6 0

NOTE.—If a strong wind is blowing, the sag value should be increased. Interpolate for temperatures and spans not given. When any other size than a No. 9 B. W. G. wire is used, it will be necessary to compute the sag required. Instructions for doing this will be furnished by the district inspector.

Sag may be handled in the following manner: After a half-mile reel of wire has been pulled out, linemen, who follow, carry the wire up each pole on their shoulders and place it between the bracket and the pole. When this has been done over the entire half mile, the line is stretched by means of a Buffalo grip and stretcher-block until it is taut, or until the two or three linemen who are on the poles along the half-mile stretch pass along the signal to stop. About two minutes' rest is then required for the line wire to "creep" along the entire distance. It should then be loosened or stretched tighter, according to the signals of the men on the poles, who can sight from the bracket of one pole to the brackets of the adjacent poles and determine when the proper amount of slack has been provided.

#### 7—TYING IN WIRE

On straight lines the wire should be tied to the inside of the insulator, so as to bring it between the insulator and the pole. On curves and corners the wire should be tied to the insulator on the outside, so that the strain will be against the bracket and the pole.

On pole-line construction the tie wire (the wire used to fasten the main line to the insulator) should be of the same size as the line wire. The method of tying wire to a glass insulator is shown in Fig. 22.

In making the tie great care should be exercised to avoid twisting the wire so tightly that the main line will be burned.

Linemen should be cautioned against nicking the line wire in making ties, especially when this is hard-drawn copper. The latter should always be tied by hand. Pliers, connectors, or other tools should be used only with iron wire. Linemen should also be cautioned against leaving the ends of the tie wire protruding, lest through twisting of the pole a contact be made.

(a) *Tying galvanized-iron wire.*—There are two methods of tying galvanized-iron wire. The regular tie (Fig. 22) should be used on all poles except where there are sharp dips or changes in level in the line wire, or in crossing railway rights of way, or on spans from 250 to 500 ft. in which cases the "figure 8" should be used (Fig. 23).

When the work of stringing wire on a pole line is stopped for a short time, or at the end of the day, the last tie put on will be a figure 8 tie. The line wire will then be continued over the bracket of the next pole without being tied, and brought down and anchored to the butt of the next farther pole by means of a Buffalo grip and either stretcher-blocks or a snub.

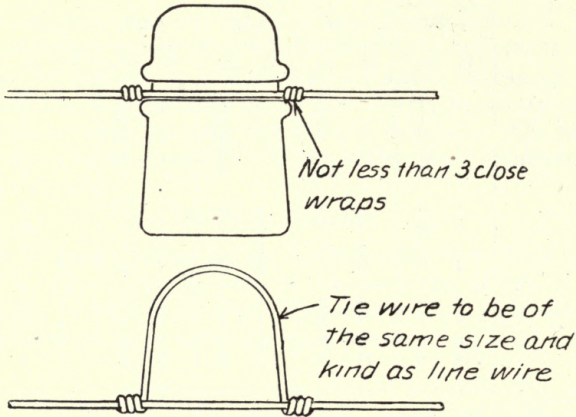

Fig. 22 Method of making regular tie for iron wire

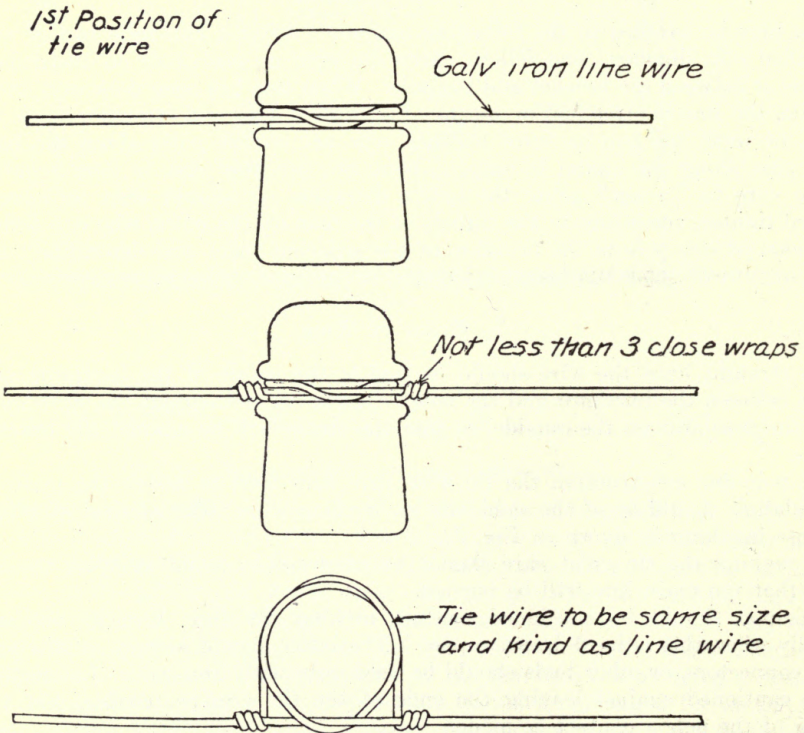

Fig. 23 Method of making "figure 8" tie for iron wire

The figure 8 tie is made by first bending the tie wire into a horseshoe shape just large enough to fit the insulator, putting it over the line wire (first position, Fig. 23), which has been placed in the groove of the insulator, and then bringing the two ends

of the tie wire around the insulator in opposite directions and wrapping them tightly around the line with not less than three wraps, as close together and as tight as possible, using pliers or connectors for the purpose.

The line should be dead-ended (Fig. 24) at such places as the first or the last pole on a main or branch line, or at a station.

(b) *Tying hard-drawn copper wire.*—All tie wires for hard-drawn copper wire should be of the same size as the line, but of annealed (soft) copper. Soft tie wires may be purchased in bundles or they can be made by cutting up the line wire and heating and then cooling it slowly to make it less brittle. Care should be taken not to heat the wire too hot, so that it pits, or to cool it too quickly. Hard-drawn copper wire is dead-ended by the use of a half-length, double-tube copper sleeve.

The regular tie for copper wire (Fig. 26) should be used in all cases except where a figure 8 tie is required (Fig. 27).

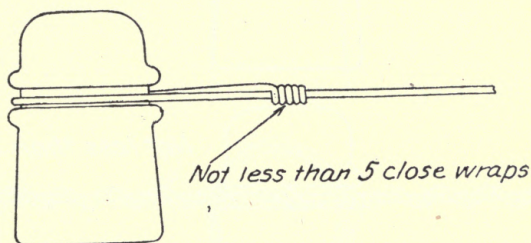

Fig. 24 Method of dead-ending iron wire

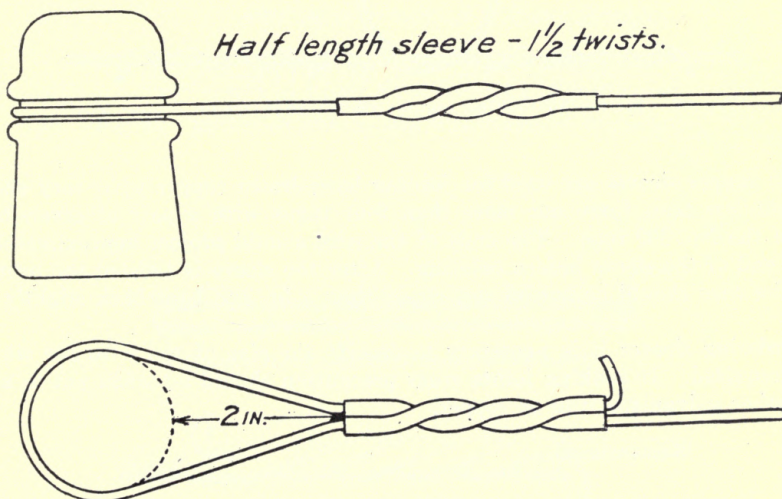

Fig. 25 Method of dead-ending hard-drawn copper wire

#### 8—SPlicing WIRE

The standard Western Union joint (Fig. 28) or the standard three-wire splice should be used for uniting galvanized-iron wire, and the standard double-tube copper

sleeve for hard-drawn copper wire (Fig. 29); galvanized-iron sleeves should not be used. Copper sleeves should not be used for splicing galvanized-iron wire, because the resulting corrosion of the latter results ultimately in a high-resistance joint which may become the equivalent, from an electrical standpoint, of several miles of extra line.

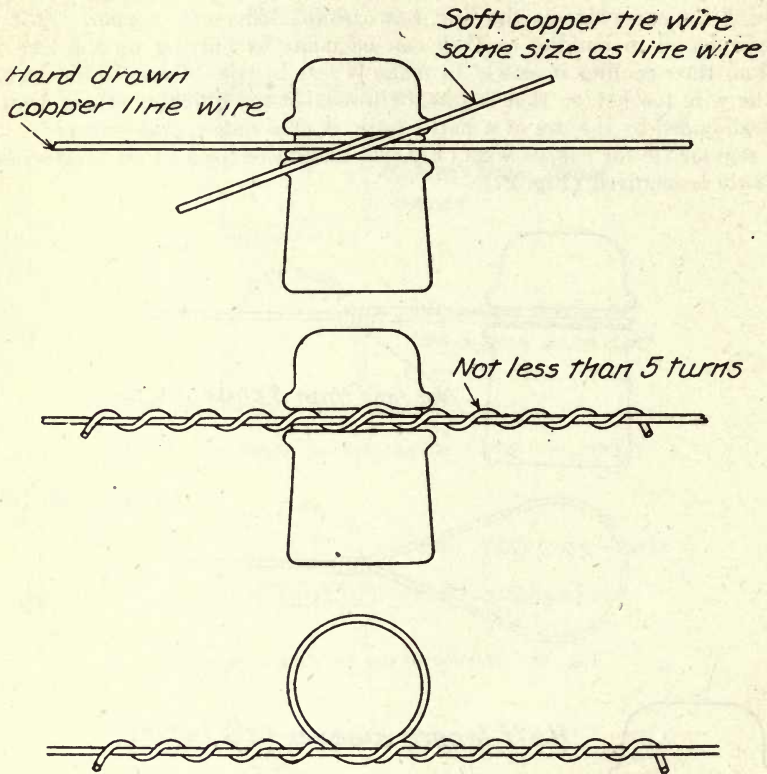

Fig. 26 Method of making regular tie for hard-drawn copper wire

When copper sleeves are used for joining hard-drawn copper wire, they should be twisted not less than three nor more than four turns with a pair of reversible connectors of the No. 309 type. The ends of the wire should project approximately 1 in. from the end of the sleeve before twisting. After the sleeve is twisted the protruding ends of the wire should be cut off not closer than  $\frac{1}{4}$  in. and bent back slightly on the sleeve.

In ordering sleeves it is necessary to specify the size of the wire for which the sleeve is required. In making joints every precaution should be taken not to nick the wire, whether galvanized iron or copper.

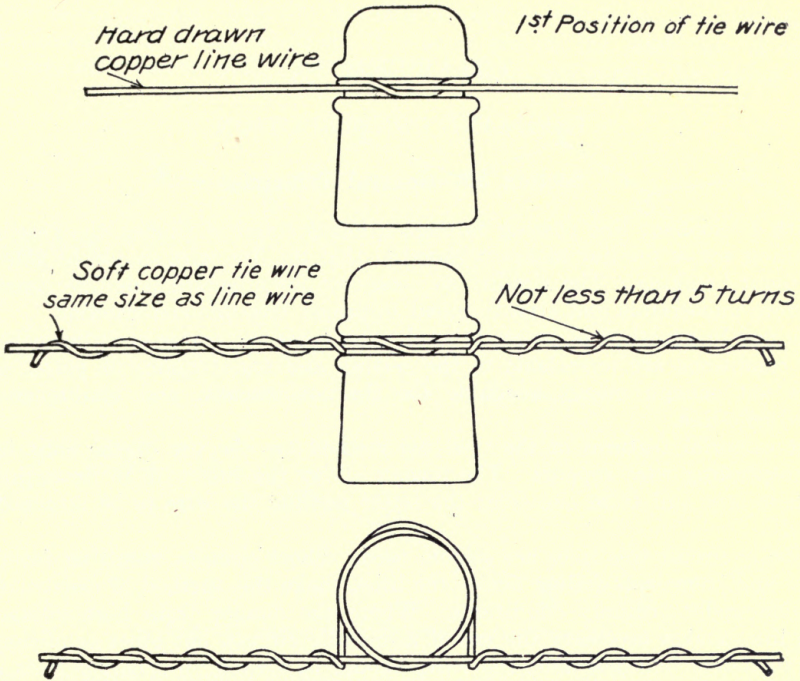

Fig. 27 Method of making "figure 8" tie for hard-drawn copper wire

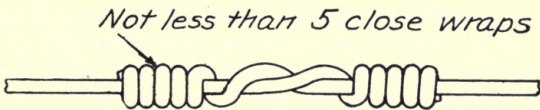

Fig. 28 Method of splicing iron wire (Western Union joint)

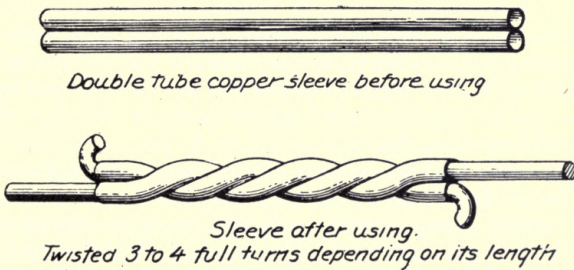

Fig. 29 Method of splicing hard-drawn copper wire

## CHAPTER IX

### TREE-LINE CONSTRUCTION

#### Section 58—General Principles

With a telephone line passing through a heavy stand of timber, the possibility of trees falling across the line makes it essential that the line wire should be able to give way without breaking. The rigidity so necessary for standard pole-line construction is therefore undesirable and even inimical to proper tree-line construction.

The tree-line method is generally used when poles are scarce or inaccessible, when ground conditions are unsuitable to the setting and maintenance of poles, or where there is not enough money available for the construction and maintenance of a standard pole-line.

The essential features of the tree-line method are the use of the split insulator and a suspending wire support. The former allows the line wire to draw through it when there is a pull from one side; the latter permits the wire to be attached to the tree itself.

Metallic-circuit tree lines are seldom used. Short circuits, resulting from broken wire ties and from trees falling across the lines, make this method of construction impracticable under ordinary conditions. Where the danger from high-voltage transmission lines makes necessary the use of a metallic circuit, but other conditions make the use of a tree line desirable, the wires should be strung on separate trees and the standard methods of transposition followed. Under no circumstances may a metallic tree line be undertaken without authorization by the inspector.

#### Section 59—Selecting Trees and Route

Judgment and care should be used in selecting the trees to support the line, and also in determining the tying place on each tree and the method of tying. Only sound trees should be selected, of sufficient diameter to minimize the swaying, but large and smooth trees that are difficult to climb should be avoided. The course of the line should be varied to take advantage of trees that will lessen the cost of construction; but if suitable trees are not available, poles should be used.

In tree lines the spans should not exceed 175 feet. If possible the average span should approximate 100 feet, and may be shorter if necessary. *The span should be equalized*, that is adjacent spans should be as nearly of equal length as possible and no abrupt changes in length of spans should be made. The crooks and turns of the trail should not be followed unless to do so would mean more economical and better construction. The line wire should never touch the trunk of a tree, and care should be taken when attaching the insulators to see that the pull of the wire is away from the tree and not against it. On side-hill slopes the line will be strung, if practicable, below the trail, so that in case the wire comes down it will not fall on the trail. Wherever possible avoid crossing the trail.

In selecting trees for ties two systems of alignment are followed both of which give good results. In the first system (Fig. 30) the effort is made to select the trees so that they follow a regular zigzag course, each tree being on the opposite side of the right of way from the two adjacent ones. The amount of pull between adjacent trees on the same side of the right of way should be 6 to 8 feet. The wire then forms a zigzag over the cleared right of way and pulls away evenly from each tie tree. The insulator, of course, is attached on the inner, or concave, side of each crook in the line.



In the second system (Fig. 31) the line is built in the form of a series of long reversed curves. On curves, while all insulators are on the same side of adjacent trees the wire nevertheless pulls away from all trees on the curve. By laying out the

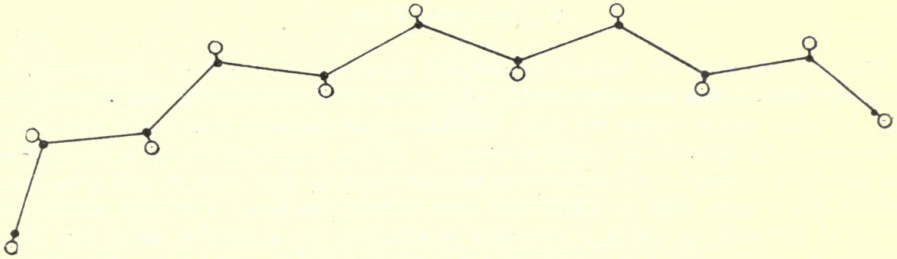

Fig. 30 Zigzag system of alignment

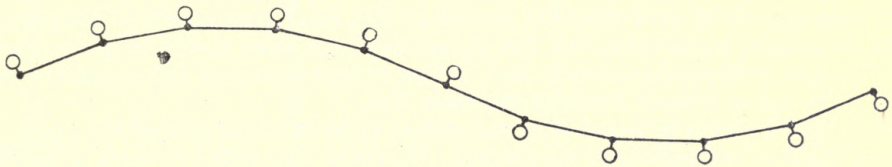

Fig. 31 Reverse curve system of alignment

entire line in a series of reverse curves, each of six or eight spans in length, the desired pull away from the tie trees is secured without the frequent crooks in the line encountered in the first method.

### Section 60—Line Construction

#### 1—THE "SIX RULES" FOR TREE-LINE WORK

For successful tree-line construction, the following six rules should be kept constantly in mind:—

- |                    |   |
|--------------------|---|
| 1 Slack wire.      | 4 Standard installations.                 |
| 2 Equalized spans. | 5 No sharp turns in line.                 |
| 3 Weak ties.       | 6 Avoid attaching wire too high on trees. |

#### 2—LINE MATERIALS

For tree-line work, only No. 9 B.W.G., B.B., galvanized-iron wire, or heavier, can be successfully employed. *This is true, regardless of the length of line.* The strains to which tree lines are exposed are much greater than with pole lines and no wire of lighter weight than No. 9 will resist them successfully. Copper wire cannot be employed at all with this method of construction. Although tree-line methods involve the building of a very crooked line with a great deal of slack, the actual length of wire is not thereby seriously increased. Only about 100 feet per mile of line wire need be allowed for the normal crooks and slack of a standard tree line.

For tie wire No. 12 B.W.G., galvanized-iron wire is employed. A mile of No. 12 wire will make about 2,700 tie wires or enough for approximately 60 miles of line, allowing 45 ties to the mile.

Split tree insulators and 4-in. staples, sufficient for 45 to 50 ties per mile of line, are the only other line materials required. The latest form of split tree insulator (See

Appendix E) which is elliptical in cross-section not only avoids several of the more serious defects of the original circular and hexagonal types but is much heavier and of better material, and therefore stronger. It will be standard on all Forestry Branch lines.

### 3—STRINGING WIRE

The methods given in Section 57 are also applicable to tree-line construction, although the latter offers less opportunity for the use of a wagon. The same precaution should be taken not to injure the wire. In most cases the only practicable way to pull out the wire is by hand from a stationary reel. Where very thick brush is encountered along the right of way it will sometimes require three or four men to pull a half-mile length of No. 9 wire, with an additional man to tend the reel. Two men should take the end of the wire to which a cross-bar is attached for a handle, while the others distribute themselves along the right of way as the strain becomes heavy. It is important to remember to remove the cross-bar from the end of the wire, and to straighten out the latter after having pulled out the coil.

A large amount of slack should be provided. The exact amount will be determined by the conditions, topography, etc., but, in general, each span should be given about 4 ft. The aim is to provide enough slack so that several trees may fall across the line within a few spans without breaking the main line.

This should always be tested after the wire is up by catching hold of the line wire between supports and pulling to the ground. It should have sufficient slack to permit this to be done in every span, and, where slack-holding ties are used, at least four times simultaneously between each pair.

Under ordinary conditions the use of brackets in tree-line construction should be avoided.

### 4—HEIGHT OF WIRE

The wire should not be hung at a greater height than on a pole line and in general should be hung about 18 ft. above the ground at the point of attachment, giving 14 ft. at centre of span.

### 5—SPLIT TREE INSULATOR ATTACHMENT

The method of making the split tree insulator attachment is shown in Fig. 32. C and D are the insulator attachments that have given the best results. The former uses No. 12 wire and comes loose from the staple whenever a tree falls across the line. In such cases neither the tie wire itself nor the split insulator breaks. To make repairs it is merely necessary to replace the attachment on the staple as illustrated in the figure.

The attachment D involves the same principle, but uses No. 9 wire. When this is employed it is necessary to keep only one kind of wire in stock, though the tie C is the least expensive and the easiest to make. E shows a little stronger attachment made of No. 12 wire which should be used in conjunction with the crosstie shown at A. All ties should be attached to the tree by means of a 3-in. or 4-in. staple, according to the thickness of the bark, about 1 in. of the staple being left protruding from the tree. A 2½-in. post staple may be used in hardwood timber. When there is a possibility that the tree to which the insulator is attached may be cut into sawlogs, a wire wrapped around the tree with a loop twisted in the middle should be used instead of the staple.

The staple should be set with its two points in a vertical plane. The split insulator is attached to the line wire by the lineman before climbing the tree. Particular care must be taken in forming the loop of the tie wire around the staple to see that it is snug and that the reversed ends are left about 2 in. long and closely parallel to the shank of the tie. A very great variation in the amount of pull required to detach this tie can be secured by altering the shape of the loop around the staple, and if not pro-

perly made it may be found that the ties pull loose under the weight of the line wire alone. This must, of course, be avoided and the ties so made that they will not only support the wire but also withstand the shock of falling trees up to the point where it threatens to break the line.

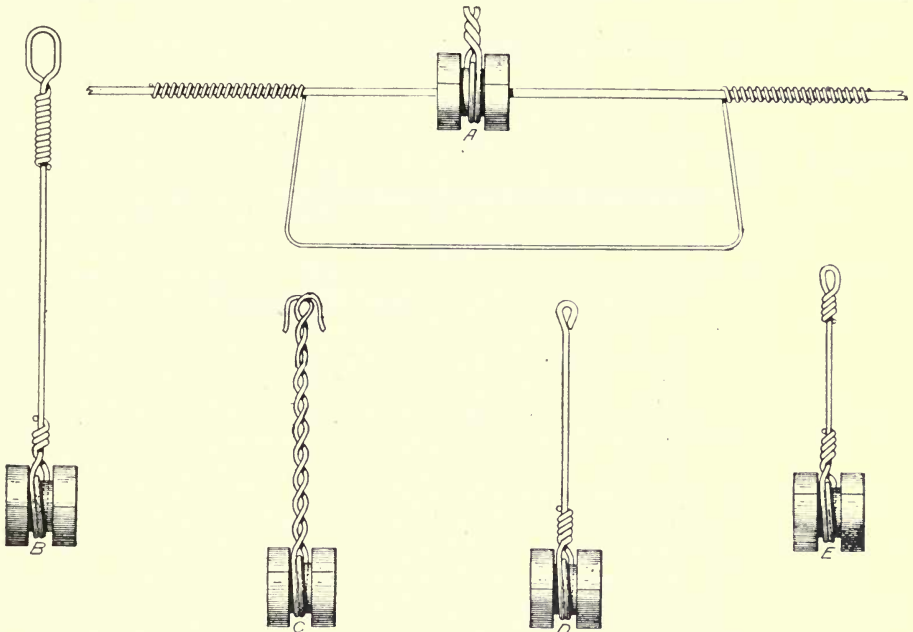

Fig. 32 Split tree insulator attachment and crosstie

6—CROSSTIE

Fig. 32 A illustrates a complete crosstie with a No. 9 wire running through the insulator. Such a tie should be used wherever it is desired to prevent the wire from running back after breakage of the main line. It should be made of No. 12 wire and be from 20 to 25 in. long. This tie is usually preferable to the insulator and bracket dead-end, in that it lessens the chance of the main line being jerked by heavy winds.

The line should be stayed at the top of hills or the beginning of steep slopes. It is not necessary to stay it on comparatively level ground if spans are properly equalized.

The use of crossties should be avoided as much as possible. Perfect equalization of spans will enable this to be accomplished in any but mountainous country.

7—DEAD-ENDING

So far as is practicable lines should be dead-ended and poles set and braced for that purpose. One or, if necessary, two brackets set close together may be used, the method of fastening wire being illustrated in Figs. 24 and 25. When dead-ending on trees the bracket-and-insulator method is not desirable, but instead the No. 500 white strain insulator attached to the tree by four to six wraps of standard galvanized strand should be used. The tree should be protected by four shims or cleats of wood. This method is illustrated in Fig 33.

Dead-ends should be used in the following situations:—

- (1) At terminals of lines
- (2) At the ends of all extra long spans
- (3) At the tops of all long stretches of line, or steep slopes where the standard crosstie is not adequate to stand the strain.

## 8—SPECIAL TYPES OF CONSTRUCTION

In regions where there is little timber and practically no danger from windfall a No. 3½ porcelain knob fastened to the tree with a 6-in. spike may be found satisfactory. It should not be used, however, without the permission of the district

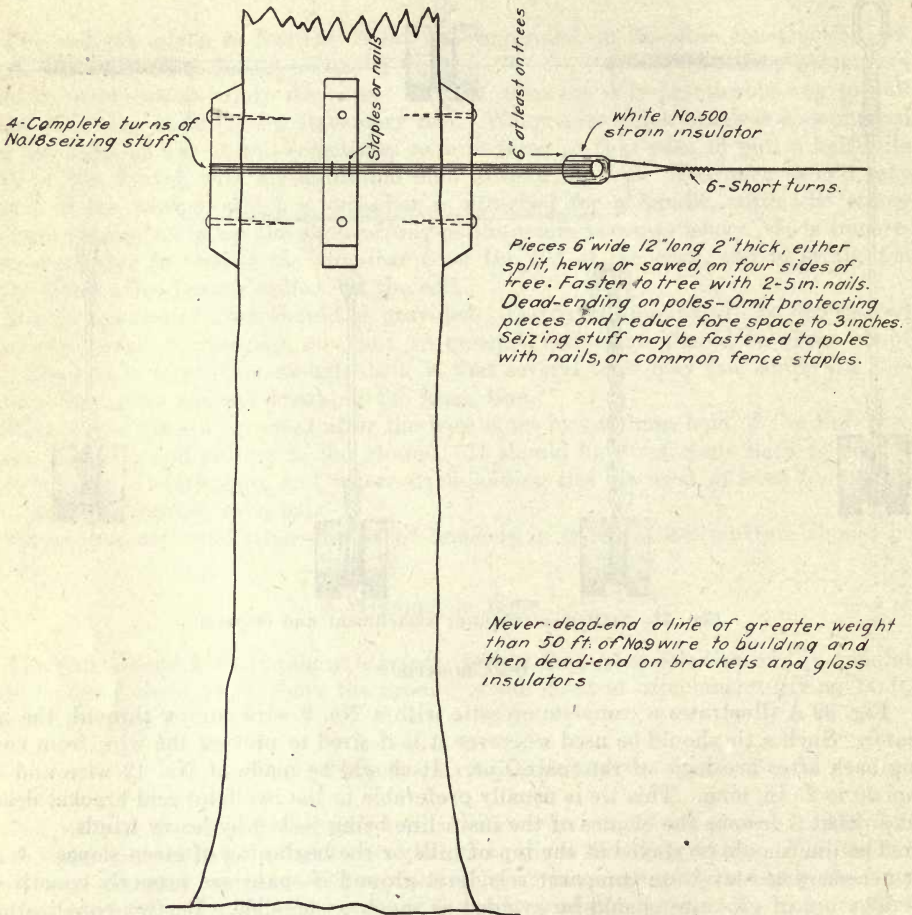

Fig. 33 Method of dead-ending on tree lines

inspector. In this type of construction the spans should average about 100 ft., with from 10 to 15 ft. of sag, according to the length of the span. A No. 12 wire should be used to tie the main line to the insulator, using the tie indicated in Fig. 26. This method will be found satisfactory only in large, open western yellow pine and similar types where there is little windfall and almost no sway of the trees at the point of attachment of the insulator. It should not be used for any but short branch lines or on short, alternative routes.

The spike should be driven into the tree for almost its entire length, leaving only about 1½ in. exposed. Since the weight of the wire falls on the top of the insulator, the strain on the tie wire is small. The lower branches of the tree should not be trimmed, since they tend to prevent the line from grounding when a tree falls on it.

In some regions of excessive winds where deciduous species, such as poplar, are used for tie trees, it has been found that the constant sway of the ties causes them

rapidly to wear thin at the staple. In these situations windfall is often not very great, and good results can be secured by tying the insulator down to a nail or staple set below it or by abandoning the use of the staple entirely and wiring the split insulator tight against the tree with a loop around the tree itself. Still another method that has proved satisfactory is to employ the tie shown in Fig. 32E, but instead of making a plain loop of wire around the staple, to use galvanized-iron wire-rope-thimbles around which to make this loop. Get the size used with  $\frac{1}{8}$ -in. wire rope.

A similar method can often be used to advantage in constructing pole lines through dense stands of small, dead spruce, so common in the northern forest. In this region it is sometimes impracticable to cut an adequate right of way at once, for lack of funds, but a pole line is necessary for lack of suitable tree supports. Under these circumstances poles should be set in straight lines as for a pole line but split insulators tied down to a spike below the wire should be employed. All large, dead snags should be cut, and when later a full right-of-way clearing is made the regular bracket and pony glass insulator may be substituted.

#### 9—CROSSING MEADOWS AND PARKS

It may sometimes be preferable to cross small meadows and parks instead of making the detour necessary to the continued use of trees. Poles should ordinarily be used to make crossings of this kind.

When not more than six or eight poles are necessary, they should be considered as trees, and the line wire attached to each by a split insulator, allowing as much slack as elsewhere in the line. In this way no injury to the portion of the line in the park or meadow will be caused by a tree falling on an adjoining span. If a large number of poles is required, the first eight poles on each side of the meadow should be equipped with split insulators. For the remaining distance the standard pole-line construction with the sag in the spans as indicated in Table D should be used. Do not "stagger" any of the poles unless they are properly raked and guyed to withstand the strain.

#### 10—CROSSING RIVERS AND CANYONS

Where it is necessary to cross a river or canyon less than 500 ft. in width, a pole should be set (do not use a topped tree) on each side of the canyon or river and securely anchored. Each pole should be equipped with double brackets and the wire tied to the insulators with the figure 8 tie.

Where the span exceeds 500 ft., specific instructions should be obtained from the district inspector before construction is begun.

#### 11—CROSSING DIVIDES AND BUILDING TO LOOKOUT POINTS

Two methods may be followed in constructing lines across divides and watersheds and to lookout points.

The usual tree-line construction should be used when the timber is heavy and such construction practicable. The line should follow a trail or road. Frequent switch-backs may be necessary in order to get over the divide.

The line should be hung in split tree insulators, using the regular attachment C, Fig. 32, except on trees at very abrupt changes in line direction. At such points a tie wire similar to B or E, Fig. 32, should be used, the tie being made of single No. 12 B.W.G., B.B., galvanized wire. This tie is lighter than the main line and a trifle stronger than the ordinary ties (C and D, Fig. 32), and will break as soon as more than one tree falls across the line, thereby providing all of the slack between the tree at the turn and the adjacent trees.

The second method will be followed when the trees are scarce or when the other method of construction is not practicable. The line should be run straight up the side of the mountain. Brackets and glass insulators should be used, and the wire tied to the outside of the insulator with No. 14 B.W.G., B.B., galvanized-iron wire, which is very light and will break easily. About 4 ft. of slack should usually be allowed for a 100-ft. span.

## CHAPTER X

### EMERGENCY LINES, CONSTRUCTION AND USE

#### Section 61—Use in Forest Protection

For the purpose of quickly establishing telephone communication at points not on a permanent line, the military system of laying light insulated wires on the ground has been adopted. The more thoroughly organized the protection staff becomes, the greater is the need for maintaining direct communication between all its parts. Emergency lines serve two main purposes in forest protection, but they are also extremely useful in general administration work on forest reserves. In protection work they have the following application:—

(1) To connect the ends of a permanent line across a break caused by forest fire, landslide, or other serious damage to the line. This is required where it is important that the use of the permanent line continue without interruption and where the repairs will require some time.

(2) To connect fire-camps, commissary camps, and other important points on the fire-line or line of communication with headquarters in the rear. This is usually accomplished by connecting the temporary camps with the nearest permanent telephone line. Heliograph stations may similarly be connected with the fire-camp nearby.

In general administration on forest reserves various kinds of temporary camps are established, all of which may require telephone connection to attain the greatest efficiency. Emergency lines will serve to provide such connection if a comprehensive system of permanent lines has been installed.

#### Section 62—Line Construction

##### 1—LINE MATERIALS

The wire adopted for emergency lines in forest protection is approximately a No. 20 B. & S. gauge consisting of 10 strands of No. 30 B. & S. gauge hard-drawn copper wire twisted together and insulated with a double-reverse, close serving of cotton, waterproofed with asphaltum compound. (For specifications see Appendix E.) It has a resistance of about 53 ohms per mile or approximately the same as No. 14 B.W.G., BB., galvanized-iron wire. Its weight is 20 pounds per mile, and its breaking strength 48 pounds. This wire is purchased in half-mile lengths wound on wooden spools conforming to the standard specifications. (See Appendix E.)

The only other line-construction materials required are some rolls of cotton tape (stationers' red tape is good) or some balls of cotton package twine, and some 3-in. wire nails.

##### 2—LINE TOOLS

The crew employed in laying an emergency line requires the following tools and material:—

1 2½-in. screw-driver	1 roll friction tape
1 pair 6-in. side-cutting pliers	1 forked pole or crook-stick
1 emergency wire reel	1 ball cotton twine
1 pocket-knife for each man	Supply of 3-in. wire nails.
1 hand-axe for each man	

If this equipment is not readily available the work may still be done with only the forked pole and a heavy hunting-knife such as is described under Section 83. (See Figs. 64 and 66).

### 3—WIRE CREW

A crew of two men will suffice, but more should be employed if available. One man is required to carry the reel. The rest of the crew follow behind and place the wire in position along the route. In some cases another portion of the crew must be sent ahead to cut and set poles or stakes to which the wire is attached.

### 4—CONNECTING TO PERMANENT LINES

A connection to an overhead permanent line with emergency wire should be made at a pole or tree. Make bare 8 to 10 in. of the copper conductor and wrap tightly around the line wire, after scraping the latter clean. Tape the joint to prevent slipping. If connection is made at a tree, place a crosstie around the split insulator in the usual manner and connect with the emergency wire outside this tie. Carry the wire down the side of the tree or pole, holding it by tape, to a point about 12 ft. from the ground, from which it is led off to the emergency station.

### 5—STRINGING WIRE

Insert a spool of wire in the reel and tighten up so that the wire will come off freely from the underside of the spool. The reel carrier must then go ahead with the reel strapped to his back, following the route the line is to take. Care must be taken to see that the reel does not overrun or the wire get into snarls. The wire must not be dragged over the ground. Under no circumstances should it be pulled from a stationary reel, as is iron wire.

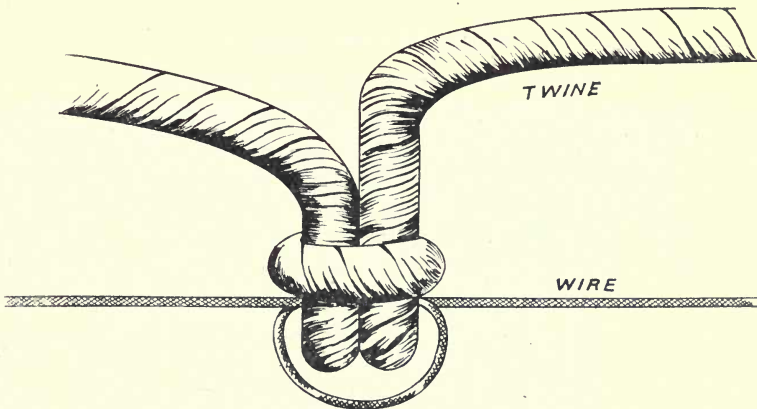

Fig. 34 Method of tying up emergency wire

One or more men must follow closely behind the reel to tend the wire. These men should carry light forked sticks about 7 ft. long with which they place the wire in a safe position. The only safe place for the wire is one in which it will not be run into by man or beast. So far as possible it should be elevated above the ground on the branches of trees high enough to be above pack animals, and where it crosses roads or trails it must be at least 12 ft. from the ground. Do not let the wire lie on damp ground as in crossing a muskeg, even if it is necessary to set light poles to raise it on. Along pack-trails and roads keep the wire at least 10 ft. from the line of traffic. *Keep the wire out of water.*

To tie up the wire to supports, use tape or cotton twine, making a barrel hitch as in Fig. 34. *Do not let the wire come in contact with nails.* Hang it from the nails by means of the twine. Make no spans greater than 75 ft. in length and do not allow the wire to be drawn tight, especially where fastened to the limbs of trees as the swaying is likely to break it.

Leave the empty spools along the line at the end of each coil. Always run the wire through the hole in the spool and place the latter well up in a tree where it will be out of sight of passers-by.

#### 6—SETTING POLES

Although for the most part emergency wire will be laid directly on the ground or looped among the lower tree branches and over underbrush, yet cases sometimes occur where a more careful placing is desirable. This can be very easily accomplished by using light poles for supports. These poles should be straight, trimmed clear of branches, about 10 to 14 ft. long and 2 to 3 in. in diameter at the butt. Any species will do. They need not be peeled and can generally be cut immediately adjacent to the line. Send the pole crew well ahead of the wire crew to cut, trim, and distribute poles at 75-ft. intervals along the route.

The pole-setting crew of three men follow the reel. This crew is provided with the following tools in addition to those furnished for wire stringing:—

- 1 pole-axe or sledge-hammer
- 1 4-ft. steel bar, or pointed pipe with drive cap

With the hammer and bar two men make the holes into which the poles can be thrust. The third man makes a deep, downward hack in the pole at the proper height, inserts the wire, ties it if desirable, and sets the pole in place in the hole prepared for it, tamping it with his heel. Several crews may work simultaneously, and with enough men cutting poles to keep well in advance of the reel the line can be erected at a fast walk.

#### Section 63—Maintenance

Maintenance is extremely important. As often as possible a man should be sent along the wire with the forked stick to see that it is kept well elevated above the ground among the trees or bushes. A line that is left out for some length of time may be very much improved in this way. If the line is broken, the break may be very difficult to find. The only safe way to locate a fault is to run the wire through the hand until the fault is reached.

Temporary joints are best made by tying a knot in the two wires as shown in Fig. 35. Peel off the insulation for about 2 in. on each wire and twist tightly together. Raise all joints above the ground and fasten to a pole or branch with tape.

After each season the emergency wire should be thoroughly overhauled. All temporary joints should be replaced by permanent joints, soldered, taped, and painted with insulating compound. Bare places in the wire should be similarly repaired, and pieces in which the copper conductor has been injured should be cut out. Reel the wire back on the spool evenly and tightly and store in a dry place.

#### Section 64—Taking Up Wire

The same reel is used as for paying out wire but is reversed and hung on the breast instead of the back. Insert an empty spool and tighten so that it will not slip on the crank. One or two men should go ahead of the reel and remove the wire from the limbs and bushes and place it in the road or trail so as to expedite reeling in. They should start some minutes ahead of the reel, and at each half-mile joint the wire should be cut and the ends made fast to a stake, tree, or some other solid support. *The men taking down wire must run the entire line through their hands so that there will be no ties left for the man with the reel to release.*



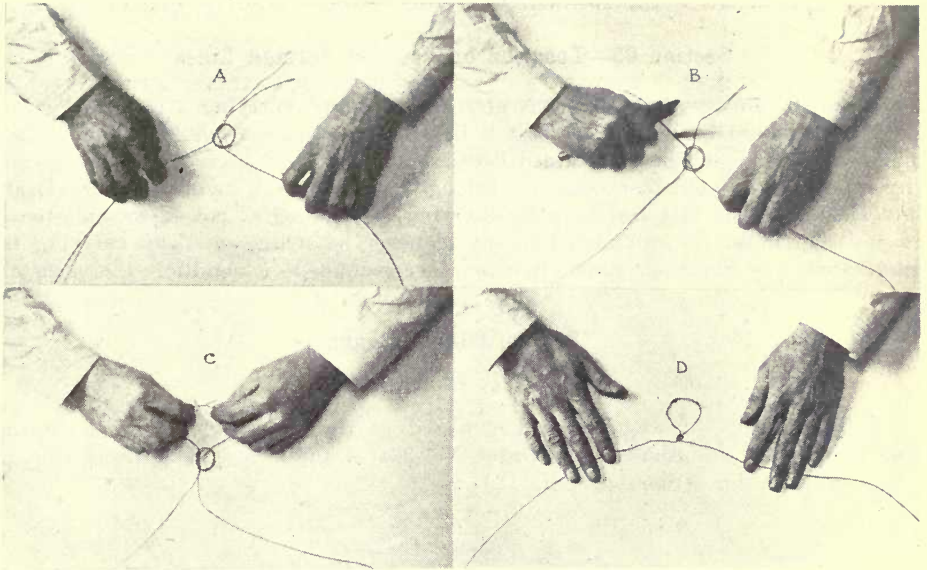

Fig. 35 Method of making temporary splice in emergency wire

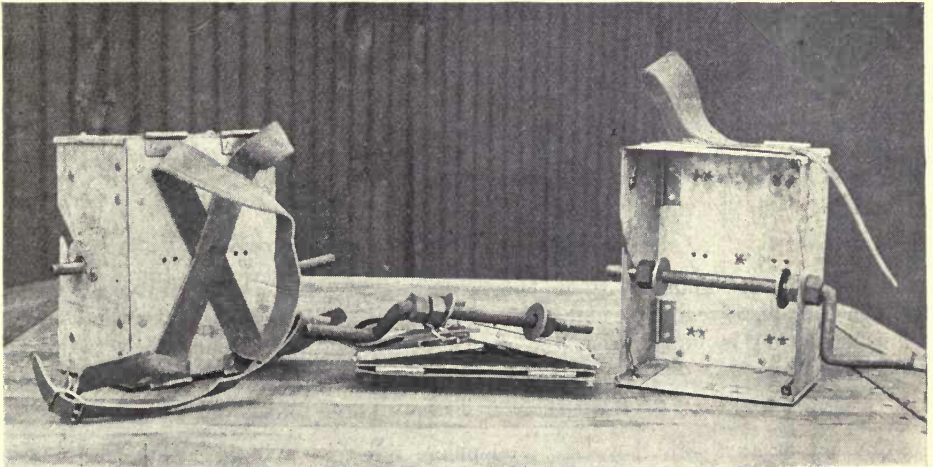

Fig. 36 Emergency wire reel, open and folded

## CHAPTER XI

### FOREIGN LINES, CROSSINGS, AND CONNECTIONS

#### Section 65—Location on Poles of Foreign Lines

When a Forestry Branch line is attached to a pole carrying a telegraph circuit, the former should be located at least 2 ft. from the nearest telegraph wire. This same clearance should be maintained between a Forestry Branch wire and any other wire on the same pole that does not belong to the same system. Forestry Branch lines should not be attached to poles carrying electric light, power, or high-tension transmission lines. A grounded line should never be strung on poles carrying telegraph circuits or other telephone circuits either grounded or metallic. Use a metallic line.

#### Section 66—Crossings

##### 1—RAILWAY RIGHTS OF WAY

Railway rights of way should be crossed at right angles. All such crossings must be made in accordance with Order No. 231 of the Board of Railway Commissioners for Canada. (See Appendix D.)

##### 2—FOREIGN LINES

Whether to cross over or under foreign lines will be determined by the character of their construction. If the foreign lines are well constructed and well maintained, they should be crossed underneath at a distance of not less than 4 ft. below their lowest wire, unless this would bring the Forestry Branch line too close to the ground. In that case a crossing should be made over the foreign line, with a distance of not less than 4 ft. between the lowest part of the telephone line and the highest wire of the foreign line. If the construction or maintenance of the foreign line is poor, the Forestry Branch line should in every case pass overhead.

##### 3—ROADS

If the line following a road, crosses from one side to the other, the crossing poles should be braced, or guyed, and a figure 8 tie used. The wire should be strung at least 16 ft. above the road, or even higher if required by provincial law

##### 4—CROSSINGS OVER 500 FT. IN LENGTH

Crossings more than 500 ft. in length may involve the use of steel-wire, special-strain insulators, towers, or bridge work, and special "A" or "H" construction. Before any construction is undertaken, the district inspector should be asked to prepare proper specifications.

##### 5—HIGH-TENSION TRANSMISSION LINES

Contact at any point between a telephone line and a high-tension transmission line endangers both the entire telephone system and the lives of those who use it. In all cases when a high-tension transmission line is to be crossed by a Forestry Branch telephone line, instructions should be obtained from the district inspector. Transmission lines should be given as wide a berth as possible. If it is necessary to run close to one, pole-line construction should be used.

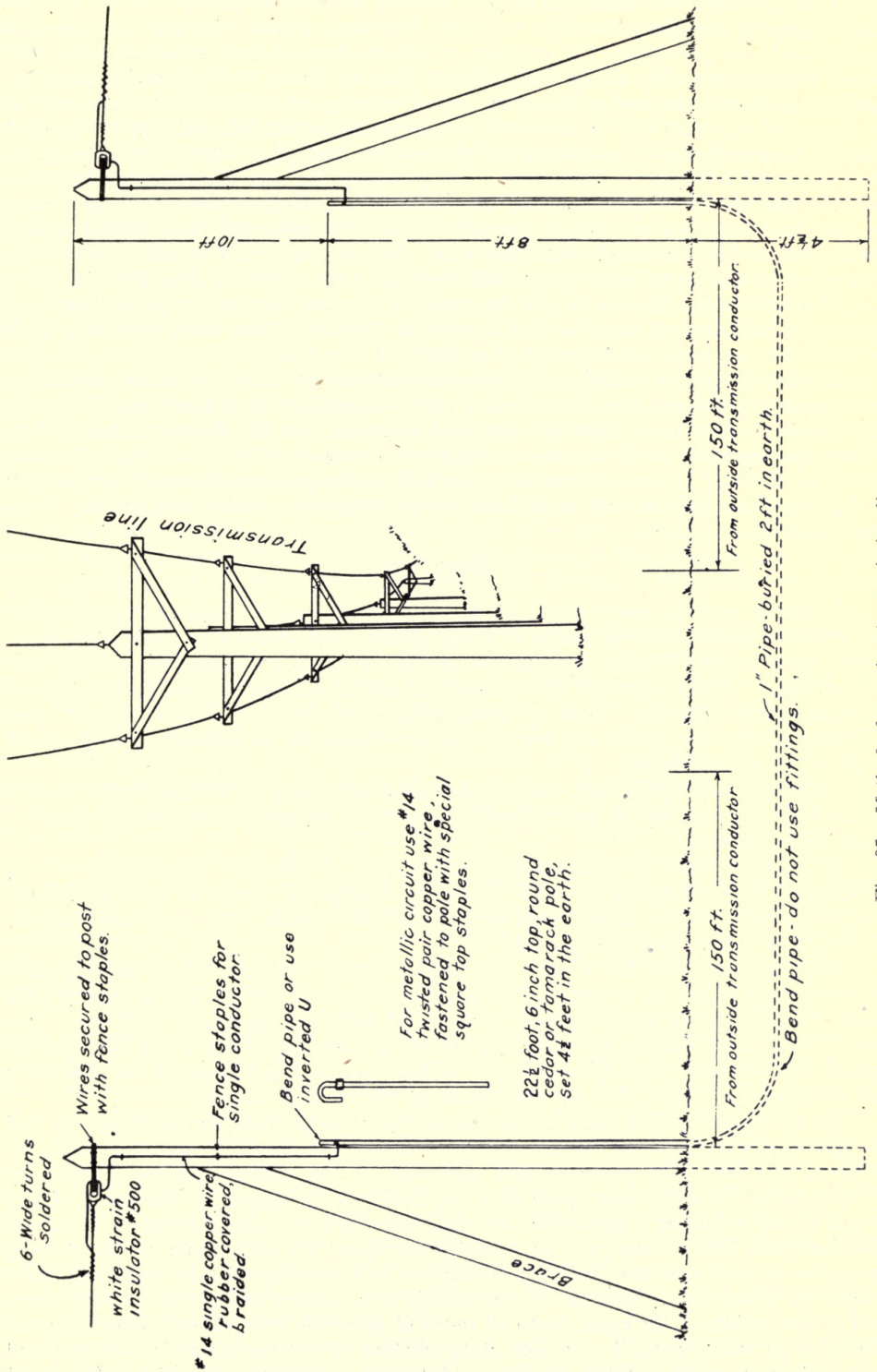

Fig. 37 Method of crossing transmission lines

Transmission lines should always be crossed at a right angle. Unless the district inspector specifies otherwise, or unless the transmission company has provided special and safe protection, the crossing will be made as follows: Dead-end the telephone line on each side of the transmission line, at least 150 ft. from the crossing, and brace or guy the last poles. The actual crossing should be made underground by means of an extra heavily insulated, rubber-covered, braided, and weather-proofed No. 14 B. and S. copper wire run through a 1-in. iron pipe, starting at a point on the pole about 8 ft. above the ground. The joints in the pipe should be made watertight by the use of red lead, and an inverted "U" attached to the top of each pipe, so that rain-water cannot follow the wire. The rubber-covered wire should extend up the pole and be connected to the line wire. In crossing with a metallic circuit both wires may be run in the same pipe. This method is illustrated in Fig. 37.

If considerable blasting would be required to put the iron pipe underground below the frost line, it may be laid across the surface of the rock, providing it is covered with an earth embankment to a depth of 2 or 3 ft.

If permission is requested for a high-tension transmission line to cross an existing forest reserve telephone line, the Director will require that the transmission line be so constructed as to provide safe and approved protection for the Forestry Branch line. Where the telephone line is exposed to voltage in excess of 5,000 volts Order 231 of the Board of Railway Commissioners for Canada for overhead crossings of electric-light and power lines will be used as a basis for determining suitable protection. (See Appendix D.)

#### 6—SUBMARINE

In many regions, particularly in the eastern forests of Canada, the necessity for crossing wide bodies of water with telephone lines arises with great frequency. Often many miles of aerial construction can be saved by a comparatively short submarine span. If properly laid with suitable material, submarine lines involve almost no maintenance charges. Cost of installation is usually very low. Against these advantages, however, there are certain serious objections to submarine lines which must be fully considered.

A suitable conductor, that may be depended upon to give uninterrupted service is likely to be very costly, particularly where there is any current in the body of water to be crossed.

A break or leak in a submarine cable causes a complete interruption of the service and it is impossible to make temporary emergency repairs as with land lines, but the cable must be raised, often at considerable expense, and permanent repairs made before service can be resumed.

A submarine cable has a very great electro-static capacity, many times greater than the same length of overhead wire, and the practical result is that a mile of such cable is equivalent to approximately 23 miles of well-built, standard land line. The use of even short submarine spans, therefore, in long land lines must be carefully considered, not only from the standpoint of first cost and maintenance but also from the standpoint of their effect on the operating efficiency of the line.

No submarine cables shall be purchased unless authorized by the Director, and on specifications furnished by him, and no such cable shall be installed until the proposed site has been inspected and approved by the district inspector. As submarine cables for still-water spans over one-half mile in length, or for spans of any length in water having a perceptible current, may have to be manufactured to special specifications, field officers will be expected to report all such cases to the district inspector at least one year before construction is contemplated. In reporting, state length of water-span, character of current, if any, nature of bottom at each shore and in the middle of the span, depth of water at intervals from shore to shore, annual variation in water level, if any; and state whether or not the water is contaminated with industrial acids or other corrosive substances or is salt or brackish. A map of

the proposed crossing site, showing the contour of the shore on each side for 500 ft. from the water-line, and a profile of the body of water along the proposed line of crossing should accompany each report.

Submarine telephone cables may be roughly divided into three classes:—

(1) Rubber-covered copper wire protected by two or more heavy servings of jute impregnated with waterproofing compound.

(2) Rubber-covered and taped copper conductor, inclosed in a heavy lead sheath, either bare or juted.

(3) Rubber-covered, taped, and juted copper conductor inclosed in an armouring sheath of galvanized-iron wires, left bare or juted.

There are no standard specifications for conductors of the third class for forest protection telephone lines and none are contemplated by the Forestry Branch, as the use of such lines on the reserves will be comparatively small. The cost of the heavy cables is so great that each case must be studied separately so that the lowest-priced cable that will give satisfactory service may be specified.

Of the cables above described, the first is the least expensive; the last, the most. Rubber-covered wires that will give satisfactory service under unusually favourable conditions may be secured as low as \$50 per mile. Heavily-armoured cables, proof against injury in all but the most adverse sites, will cost from \$500 per mile, up. Intermediate types will range between these figures in cost.

In waters having any perceptible current, either the ordinary current in a stream, or tidal or wind currents in other bodies of water, nothing but an armoured cable is likely to give satisfactory service. The nature of the currents, the contour of the crossing, and the character of the bottom will determine the weight of armour required.

In still waters, such as large lakes or ponds, either heavily insulated wire or lead-sheathed wire may be used. Insulated wire without a lead sheath should only be used in perfectly still water where there is a mud or sand bottom in which the wire will embed itself. Such waters will usually be shallow and have a fairly regular profile. If used for navigation or log-driving or rafting, the chances of the wire being disturbed by such operations must be fully considered. In nearly all cases, where the approach to the shore is on a gradual, shelving bottom, a heavy pile or tripod properly weighted should be set in the water at a sufficient distance from the shore to permit of the wire being brought to the surface in a water depth of 6 ft. to 8 ft. and carried to shore by an overhead span. The probable effect of ice on this construction must be considered. Such spans should not, as a rule, be over  $\frac{1}{4}$  mile to  $\frac{1}{2}$  mile in length and should always be tested for some months before permanent shore structures are erected. If they fail, replace with a lead-sheathed cable, making the shore connection as above, and use the insulated wire for station installations or for emergency or temporary land lines.

For spans of over  $\frac{1}{2}$  mile in still water with a mud, sand, gravel, or rock bottom, where excessive irregularities of profile do not occur, the most satisfactory cable will be a lead-sheathed one. On a gravel or rock bottom it should have an outer jute covering. The shore approach may be made as previously described, but in most cases it will be found more satisfactory to splice on to each end of the span a short length of armoured cable with which to make the shore approach from a depth of about 15 ft. Landings may be made with armoured cable where the rock slopes off very steeply into deep water; or the cable may be brought ashore on a sand or mud bottom sunk in a trench and, if possible, protected by a light covering of rocks or gravel and a few stakes or piles to warn off boats. However, if logs drift loose in the lake, or if the landing place is exposed to a heavy surf, an overhead landing is preferable.

Always set up at each end of a submarine cable crossing a large sign warning navigators against anchoring over the cable.

The actual laying of a submarine cable is very simple. The reel on which it comes wound should be mounted on the stern of a boat of suitable size, or, if none is

available, on a barge or raft. This is done by inserting a steel bar or pipe in the hole in the middle of the reel and supporting it at each end so that the reel will revolve easily on the bar. A brake by which it may be stopped should be improvised. The end of the cable should then be made fast to the shore and the boat run across to the other landing at a slow speed. Two men should tend the reel and see that the cable comes off evenly. Where any great irregularities in the profile of the bottom are known to exist special care should be taken to ensure that the cable lies on the bottom throughout its length and that there are no unsupported spans.

### Section 67—Connecting Forestry Branch Lines with Private Lines or Exchanges

Whenever it is desirable to connect a Forestry Branch line with a private line or exchange, the district inspector should first be fully advised by letter as to what arrangements can be made for the connection, including a statement of the ability to obtain night, Sunday, or holiday service, if needed in emergencies. There should also be stated the length of the Forestry Branch line, and, in cases where it is desired to connect directly to another line, the length of such line; the character of its construc-

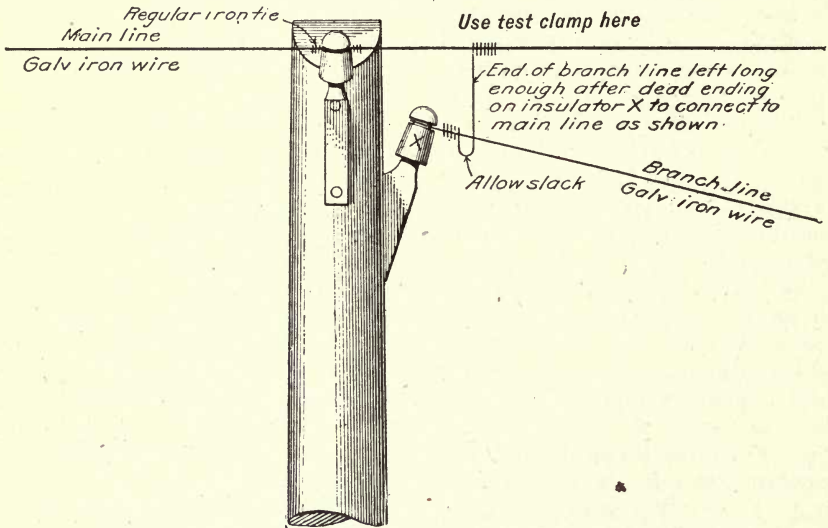

Fig. 38 Method of connecting branch line to main line when both are galvanized-iron wire

tion and maintenance; the sizes and kinds of wire used in the construction of both lines, and whether one or both are grounded or metallic circuits; the number of instruments on both lines and the ohm capacity of the instruments on the line with which connection is to be made. The district inspector will decide the best method of handling the matter and making the connections. Every precaution should be taken to make sure that trouble originating beyond the Forestry Branch line will not interfere with it.

### Section 68—Branch Lines

#### 1—METHOD OF CONNECTION

In attaching a branch to a main line, the former should be dead-ended on a separate bracket attached to the main line pole for that purpose, so that the strain of the branch line will not come on the connection (Fig. 38). A Fahnstock test-clamp may be used to connect the branch line to the main line instead of wrapping the end of the branch to the latter. The Fahnstock test-clamp is made in three grades: Entire clamp fully

tinned, clamp half-tinned, and untinned. The first type should be used for connecting two iron wires, the second for connecting a copper and an iron wire, and the third for connecting two copper wires.

When the main line is of hard-drawn copper wire, it should be cut in two and dead-ended on the same insulator from both directions, splicing in additional wire if necessary. The ends after dead-ending should be left long enough to be spliced together in a copper sleeve, so as to complete the circuit again. The branch line should then be dead-ended on a separate bracket and insulator, and the connection made as in Fig. 39.

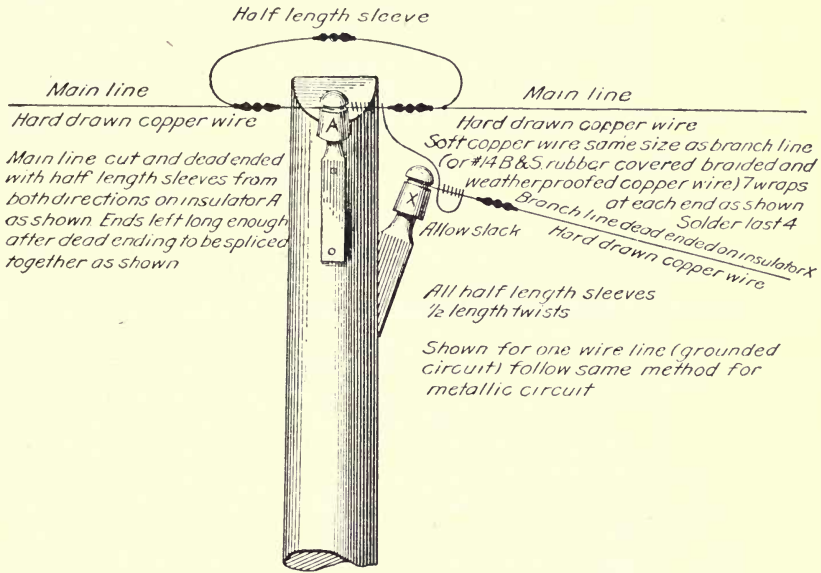

Fig. 39 Method of connecting branch line to main line when both are hard-drawn copper wire

Whenever any wire is connected to a hard-drawn copper line, the latter must always be dead-ended for that purpose, so that the wire may be soldered to a point on the dead-end loop between the sleeve and the insulator. When soldering is not feasible, the wire should be cleaned bright, and the wire to be connected should be closely wrapped around the line wire not less than seven times. A Fahnestock clamp may be used here also.

When connecting a branch line to a tree line the branch should be dead-ended on a tree by the method prescribed in Section 60 and shown in Fig. 33. The main line should be held by a crosstie and the connection between the branch and the main line made with a piece of No. 14 insulated copper wire attached as shown in Fig. 40. In order to facilitate separation of the branch from the main line, a method of installing a switch when making such a connection is illustrated in this figure.

## 2—TYPES OF INSTRUMENTS

Where a Forestry Branch line is to connect with another line, either directly or by switches, the resistance in ohms of the ringer coils in the instruments (and extension bells, if used) should be the same as the resistance of those on the connecting line. The standard resistance of all ringer coils on exclusive Forestry Branch lines will be 2500 ohms. However, in connecting with lines that use other resistance ringer coils, it will be necessary to use the same resistance coil in instruments on the Forestry Branch line. Where telephones of other resistance than that specified are needed for use, the district inspector should be consulted as to the proper set to purchase.

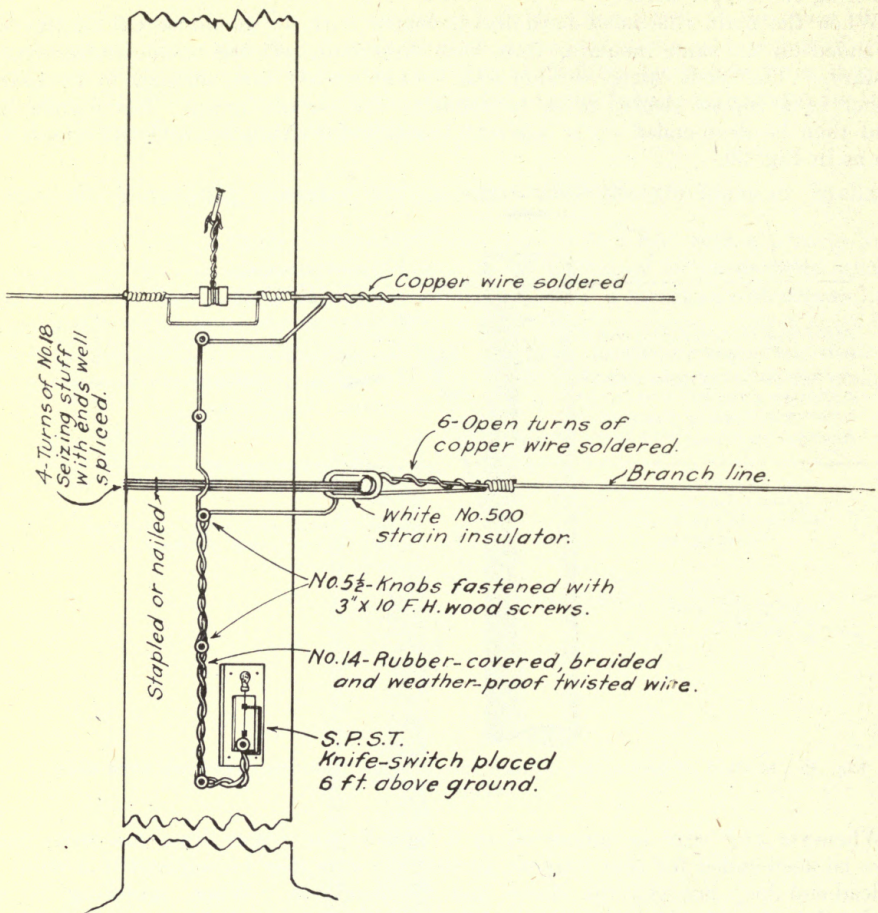

*Out of door method of attaching branch lines to main lines:*

*Where trees support the lines, dead-end as shown by Fig. 33 — Run the branch line to the main line, directly from the hanger. The main line should be fastened to a standard anchor.*

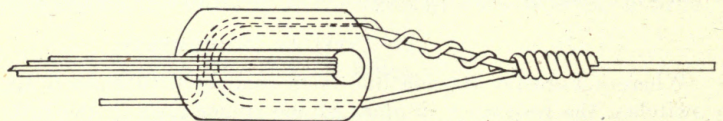

*Run copper wire through hole in strain insulator for support.*

Fig. 40 Method of connecting branch to main line in tree construction



## CHAPTER XII

### INSTALLATION OF FIXED EQUIPMENT

#### Section 69—Wall Sets

The standard wall telephone set will always be the most common type employed. It is used for nearly all permanent indoor installations, except at lookouts or main headquarters, where desk sets are desirable. The sets as received from the maker are in a partly "knockdown" condition and must be assembled. This consists of putting in place the receiver, transmitter, shelf, and generator crank. Suitable screws are provided, where needed, and holes bored for them. Directions for assembling accompany each set, as shown in Fig. 41.

The location of the instrument inside the building will always be determined largely by convenience in using it. This location should be decided upon, however, before the line wire is brought up to the building. It is customary to stand up when using a wall set, and the height of instrument must be determined accordingly. Instruments must not be attached to walls with nails. Use the four  $1\frac{3}{4}$ -in. No. 10, round-head, blued screws provided, and make certain that the screws get a sufficient hold on the wall to support the weight of the set and the extra weight of persons leaning on the shelf. Instruments installed in unlined log buildings should be attached to a suitable board and this in turn fastened securely to the wall. Always try to place the instrument so that it will be directly over the point of grounding.

Each standard instrument when received should have pasted to the inside of the door, a diagram of the internal wiring and complete directions for setting up and connecting to the line (see Fig. 41). It is to be noted that the wires from different parts of the set are variously coloured and these colours are indicated on the simplified diagram, making it easy to identify various circuits in the set itself.

The two terminals on the right-hand side of the instrument marked L1 and L2 are the ones to which the line wire and ground wire respectively must be connected. [In some older types of instruments on a few reserves these terminals are on the left side of the box. The diagram, however, will indicate connections.]

On a metallic circuit connect one of the wires to each of these terminals. *The terminal marked GND is not used at all in the set as employed on Forestry Branch lines.*

#### Section 70—Condensers

The condenser in a telephone is cut in circuit in series with the receiver. It makes possible "through" signalling when receivers at intermediate stations are off the hooks. Any telephone now in use, if not already provided, can be equipped with a condenser.

The condenser may also be cut in on one side of the ringers for testing purposes.

#### Section 71—Dry Batteries

##### 1—INSTALLATION

Three dry cells are required for all instruments except the lookout sets and the portables. Northern Electric, Blue Bell, Blue Label, or Columbia cells are recommended and those with Fahnestock clips are to be preferred to those with the common binding-post. Connect together as shown in Fig. 43, using insulated stranded wire rather than solid wire, since it is more pliable. Do not remove the paper cartons which are needed for proper insulation and take care that the adjacent zinc binding posts do not touch.

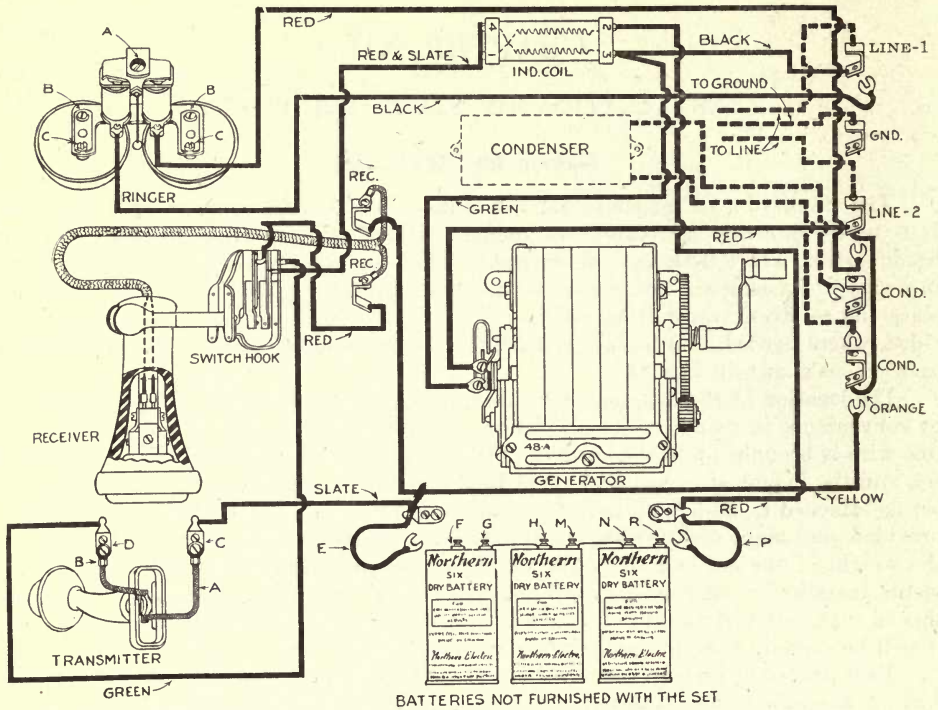

Fig. 41 Wiring diagram and directions for assembling standard wall telephone set

- Tools.**—An ordinary screw-driver is the only tool that is required for all adjustments and wire connections.
- This set is shipped connected for service on either metallic or grounded circuits with the red ringer lead to terminal "Line 2," the black ringer lead to terminal "Line 1," and when there is no condenser, the yellow receiver lead to lower "cond." terminal.
- When used on metallic line circuits, connect one line wire to terminal "Line 1" and the other line wire to terminal "Line 2."
- When used on grounded circuits, connect the line wire to terminal "Line 1" and the ground wire to terminal "Line 2."
- When used for divided ringing, that is ringing from either side of a metallic line to ground, connect the red ringer lead in one group of sets to terminal "Line 1" and in the other group to terminal "Line 2." In all sets connect the black ringer lead and the ground wire to terminal "gnd." The tip side of the central office line to terminal "Line 1" and the ring side to terminal "Line 2."
- To connect the condenser in series with the receiver.—If not already so equipped, connect the yellow receiver lead and one condenser lead to the upper "cond." terminal, and connect the other condenser lead to the lower "cond." terminal.
- To connect the condenser in series with the ringer (when the set is used in connection with common battery lines).—Connect the red ringer lead and one condenser lead to the upper "cond." terminal, the black ringer lead to terminal "Line 1" and the yellow receiver lead and the other condenser lead to the lower "cond." terminal.
- Ringer adjustment.**—The armature shall be so adjusted that the clapper ball has a movement of about  $\frac{1}{16}$  inch. To obtain this, turn the screw "A" to the right to shorten the stroke, or to the left to lengthen the stroke.
- The gongs should be so set that the clapper ball strikes but does not rest against them when thrown to either side. To change position of the gongs, loosen the clamping screws "B," turn the eccentric adjusting screws "C" until the correct position is obtained and then tighten the clamping screws "B."
- In mounting the transmitter, connect the cord "A" of the transmitter to terminal "C" inside of the door and connect the cord "B" to terminal "D" on the door.
- In connecting batteries, connect wire "E" to post "F" and connect post "G" to "H" and "M" to "N" and connect wire "P" to post "R." See that the binding-posts "G," "M" and "R," do not touch each other when the batteries are in place.
- Repair parts should be ordered by sample if possible, otherwise by accurate description, always mention, if possible, the code number of this set (it is stamped on the inside of the door near the bottom edge).

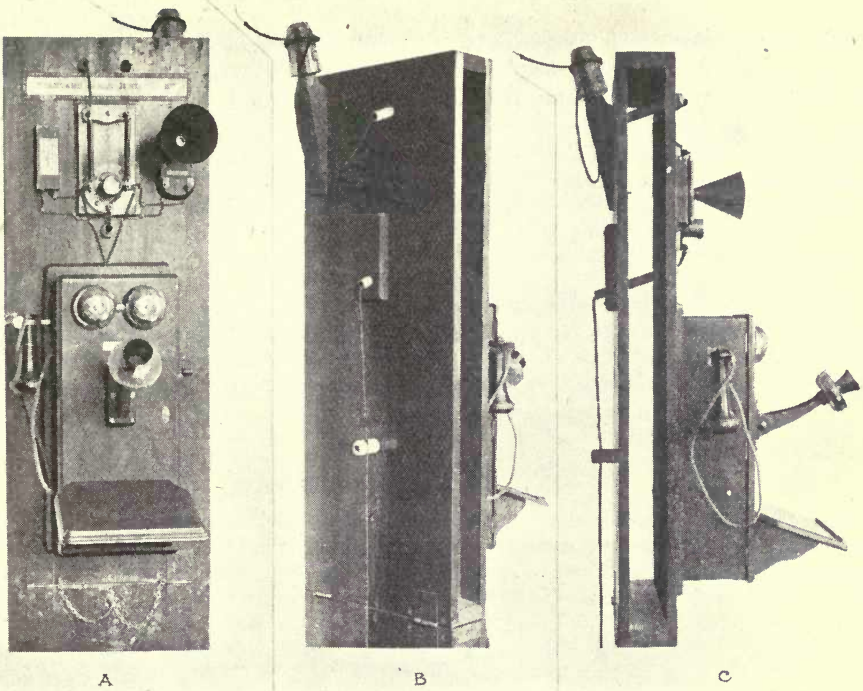

Fig. 42 Standard telephone installation  
(a) Front view, (b) Back view, (c) Side view

## 2—RENEWAL

Regular systematic renewal of all batteries at least once a year is necessary. In some cases more frequent renewals will be required. For such places the 3-in-1 battery, which consists of three cells inclosed in a waterproof casing with only two exposed connecting-posts, will often be found desirable as it has a somewhat longer life. Batteries deteriorate rapidly whether in use or not.

Two new batteries should never be installed with one old battery, nor one new battery with two old batteries, as one poor battery will spoil the efficiency of the good ones.

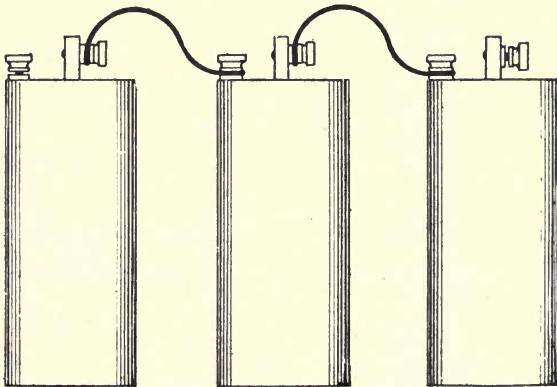

Fig. 43 Method of connecting dry batteries for a telephone

## 3—TESTING

For battery testing an Ever Ready, No. 1003 battery gauge is a cheap and fairly efficient instrument, and each forest reserve headquarters should be provided with one. Cells which test less than 10 amperes should not be accepted. Cells showing less than 4 amperes at the end of a one-minute test should be discarded. First-class Blue Bell, Blue Label, or Northern Electric cells when new may be expected to show 14 amperes on test; Columbia, 24 amperes.

## 4—REMOVAL FROM UNUSED STATIONS

Always remove the battery from the telephone in stations that are to be left unoccupied over winter, also from all outdoor sets. If left in the instrument considerable damage may result from leakage of chemicals. This is particularly true with the 1336-J set in which the battery is immediately adjacent to the generator.

## Section 72—Protectors

The question of protection is a very important matter and is divided into two classes in Forestry Branch work: (a) partially exposed substations and (b) fully exposed substations.

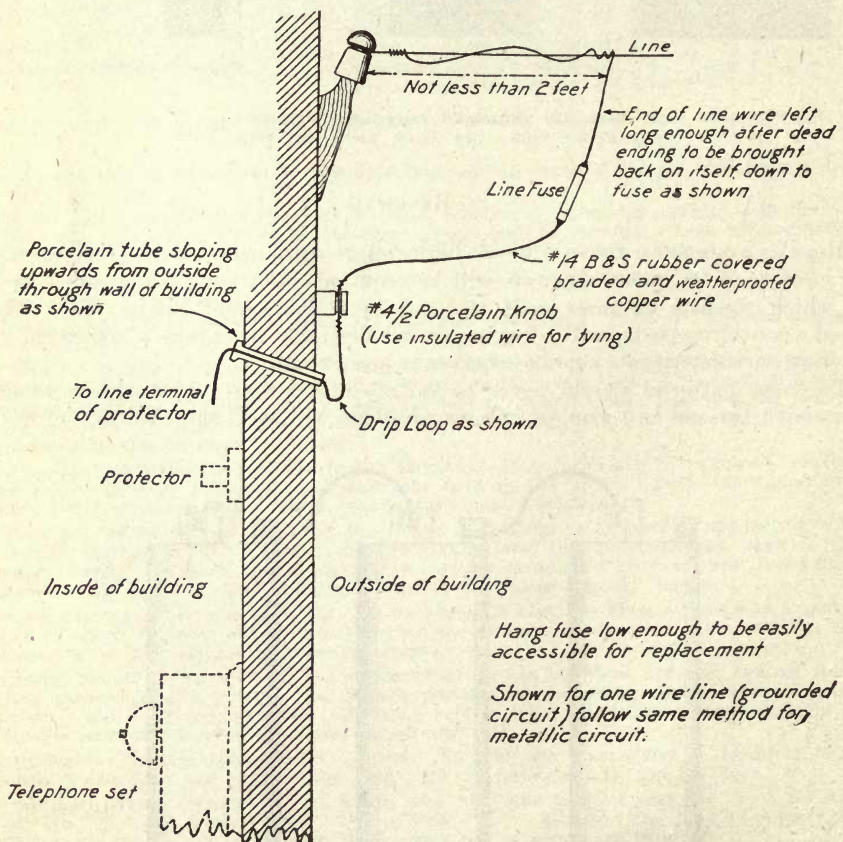

Fig. 44 Method of installing line fuse when required

## 1—PARTIALLY EXPOSED SUBSTATIONS

Where it is absolutely certain that the line is nowhere exposed to accidental contact with electric-light, power, or high-tension circuits (but only to lightning), each telephone station should be considered as partially exposed, and nothing beyond the No. 60-E protector used for protection. Where lightning is unusually severe, however, either a 47-A line fuse, in addition to the 60-E protector, or a 58-F lightning protector should be used. The former should be located immediately outside of the building and attached to the main line wire in such a way that, when blown, the wire on the side toward the line will fall away (Fig. 44). On a metallic line, where line fuses are used, a fuse should be attached to each wire. When the 58-F, which is a combination of the 60-E protector with fuses, is used, a No. 48 asbestos mat should be mounted back of all protectors and the slits in the fuses turned toward the mat. The appearance of the installation is much improved if the rough edges of all asbestos mats are bound with brass or aluminium oilcloth binding tape, as in Fig. 84.

Special provisions are required for the protection of the lookout sets (1336-J) and the portable telephones. These are discussed in Section 75, 80, and 81.

## 2—FULLY EXPOSED SUBSTATIONS

A fully exposed substation is one on a line which may be exposed to accidental contact with electric-light, power, or high-tension transmission lines. Even though only a portion of a line is subject to such exposure all stations on it will be considered as fully exposed. The 60-E protector with 47-A line fuse, or the 58-F protector, will be used at these stations. In all cases where the line is exposed to a high-tension voltage in excess of 1,800 volts the district inspector should be consulted in regard to the additional protection.

## 3—CONNECTIONS WITH FOREIGN LINES

In general, it is not necessary to consider the exposure along other telephone lines with which the Forestry Branch lines may connect, provided the connection is made through a switchboard. If made by any other means, however, one of the above-described protective methods will be used.

## 4—LOCATION OF PROTECTORS

It is dangerous to place protectors on or immediately adjacent to the telephone sets. Always install the protector at least 2 feet away from the instrument, generally at or very near the point of entrance to the building and as nearly over the ground rod as possible. The 58-F protector should be mounted upon the wall so that the fuses are vertical, and fastened in place by screws. It should not be exposed to water or dampness or be placed outdoors. When the leading-in wires enter the building above the door or window casing, the protector should be mounted so as to allow a space of 1 in. between the protector and the casing. Where the wires enter at the side of the door or casing, the protector should be mounted flush with the latter. It should always be placed at least 12 in. from curtains, shades, or similar combustible materials and should never be mounted directly above any such materials.

Ordinarily only one mica should be used between each pair of protector blocks, but in localities where lightning is excessive and the stations difficult of access two micas may be inserted, thus increasing the air gap. Paper or other material should never be substituted permanently.

The 58-F protector should be connected as follows: Connect the leading-in wire or wires to the fuse terminals marked L most distant from the protector blocks, and the inside line wires to the other end of the fuse terminals—that is, the end nearer

to the protector blocks. Connect the ground wire with the terminal marked G as in Fig. 45. In the case of a grounded line only one of the fuses is used but a short wire

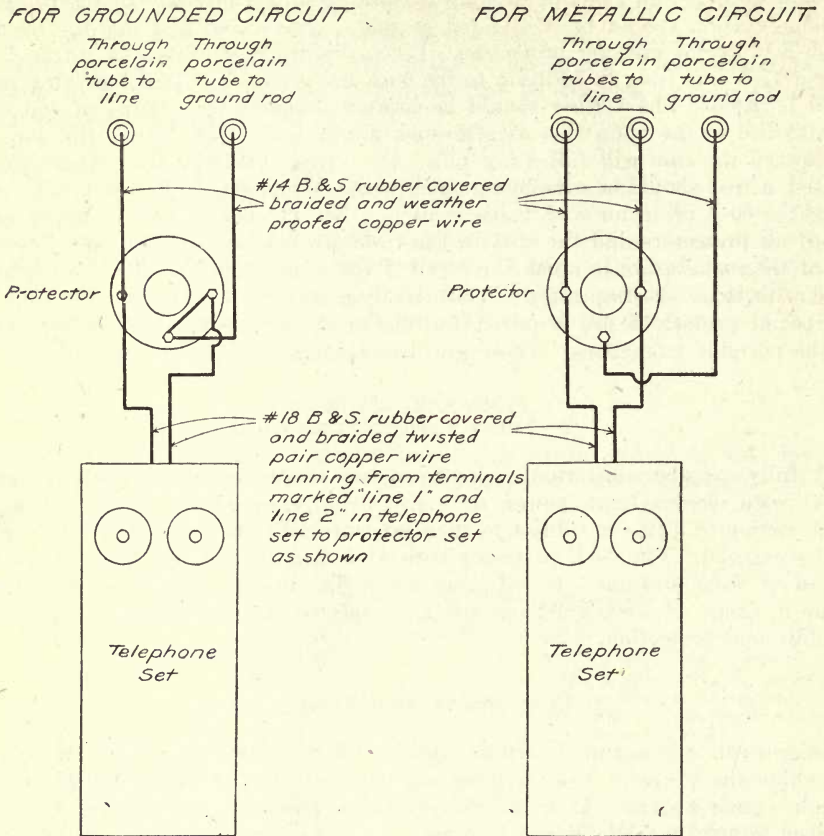

Fig. 45 Wiring diagram for telephone station

should be run on the end of the protector that contains the protector blocks, from the terminal marked G to the terminal at the side of the protector blocks that is not being used by the main line (Fig. 45).

## Section 73—"GROUNDS"

### 1—GENERAL PRINCIPLES

Telephones are grounded for two distinct purposes. In both one-wire and two-wire (grounded and metallic) lines the protective devices must always be grounded in order to function properly. One-wire (grounded) lines, however, require to be grounded in order that the return half of the circuit, the earth, may be made available. In grounded lines, therefore, the character of the ground connection not only affects the protection but also affects very seriously the operation of the telephone both for ringing and talking. Poor grounds constitute one of the most common and most annoying sources of trouble in this type of construction.

While permanently moist earth will generally afford a good ground, yet different soil materials and different geological formations do not always possess the same conducting power. This sometimes makes it necessary to test various places before

a fully satisfactory ground is secured. This is conveniently done by using standard emergency wire to make the test connections. Dry or frozen earth and rocks are non-conductors and will not give a satisfactory ground.

Nearly all grounding difficulties, however, arise from defective materials and details of installation. Even after a suitable place is located, failure to satisfy the primary requirements of good grounding, namely, *a sufficiently large, clean, metallic surface in intimate contact with permanently moist earth, will result in poor operation of the station.*

## 2—GROUNDING DEVICES

There are several first-class grounding methods. Wherever possible the standard ground rod should be used. This is a 7-ft. galvanized-iron rod,  $\frac{3}{4}$  in. in diameter. Drive the rod in so that only a length of about 8 in. remains above the ground surface. Place as near the instrument as practicable and close up to the side of the building, preferably where it will receive the drip from the eaves. If it is not possible to drive the rod vertically to its full depth it should be driven on a slant, for it is essential that the moist earth come in contact with the full length of the rod. Depth of freezing must be carefully considered, however, and if necessary to keep below frost line the rod may be driven at the bottom of a hole.

Wherever, for any reason, a standard ground rod is not available, a good ground can be made on a copper plate or coil of copper wire. The plate should be about No. 21 Birmingham sheet metal gauge or No. 21 U.S.S.M.G. in thickness and about 12 by 18 in. in size. A wire coil should be 12 in. in diameter and be composed of at least ten turns of No. 12 bare copper wire. In the former case, a piece of bare copper wire No. 12 or No. 14, must be soldered to the plate and should be sufficiently long to reach to the surface of the ground. In the latter case, one end of the wire coil is brought to the surface. The plate or the coil must be buried at a sufficient depth in permanently moist earth, and the wire leading to the surface joined to the ground wire of the instrument.

A well may be used for a grounding place, but is of doubtful value if in rock. Use a coil of copper wire as previously described and place flat on the bottom of the well, having the end at least 3 ft. above the high-water level to provide for connection to the wire from the instrument.

When it is impracticable to find permanently moist earth, a good ground may be obtained by placing a similar coil of wire or a copper plate at the bottom of a hole 6 to 10 feet deep, covering it with about 1 ft. of powdered charcoal and wetting the latter with a bucket or two of water. The hole should then be refilled and the earth tamped in securely. Charcoal is hygroscopic, and will absorb and retain moisture. *The connection of the ground wire with the coil must be soldered.* A bucket of water thrown on the ground at intervals during a dry period will add to its effectiveness.

In some buildings it is possible to use a water-pipe for a ground, in which case the ground wire should be attached to the pipe by a Blackburn ground clamp. Only pipes which always contain water should be used.

## 3—PRECAUTIONS

Under no circumstances should ground wires be attached to:—

- (1) Water-pipes of a town water supply if other lines are grounded on them.
- (2) Pipelines not carrying water.
- (3) Coils of iron wire or scraps of old iron thrown into a stream, lake or pond having a rocky bottom.
- (4) Black iron plates, horseshoes, gun-barrels, ungalvanized bars, or pipes, rain-spouts, old bolts, and similar articles. Ungalvanized iron placed in contact with the earth rusts quickly. Rust is a non-conductor and acts as an insulator. Ground trouble is sure to follow the use of the above articles.

## 4—MULTIPLE GROUNDS

The following instructions taken from the Telephone circular of District No. 5, United States Forest Service, apply to stations where several lines converge:—

“Where more than one line enters a station to telephones, extension bells, or a switchboard, all the instruments having the same ringer resistance may sometimes be grounded on the same ground rod or coil, provided the electrical contact to the earth is satisfactory.

“The efficiency of a common ground should first be tested before making permanent connections to it. Where the rod or coil is immediately adjacent to the instruments simply connect it to the instrument by a temporary wire. All points of connection should be clean and tight. If a satisfactory ground cannot be found nearby, the test may be made by stringing No. 9 wires to different places which appear to be satisfactory until good grounds are found. (Test by attaching one instrument to the wire, the wire leading to the experimental grounding-place, and if satisfactory results are obtained connect in turn lead wires from each additional instrument.) Cross-talk between the lines may be heard even if the ground is good, but it should not be pronounced. When a signal is rung over one of the lines the bells should not cross-ring; that is, two bells or more should not ring with the switches open between the respective lines. If the cross-talk is loud and the bells cross-ring, or if cross-talk is loud in the absence of cross-ringing, inadequate ground to carry the full number of instruments attached is indicated. Two or more wires leading to grounds should not closely parallel one another.

“Further experiments should be made by disconnecting one instrument at a time from the lead wire, followed by a test until the cross-ringing is eliminated and the cross-talk either eliminated or much weakened. Only in exceptional cases, if ever, can cross-talk be entirely eliminated where several grounded lines enter the same station. Seek additional ground or grounds for lines that were disconnected.

“It may be necessary in some cases, in order to get satisfactory service, that grounds be separated as much as half a mile. The expense, however, of locating efficient grounds and of installing connecting facilities is justified, because instrument installation is a failure unless good grounds are made.”

## Section 74—Wiring

To ensure good service, instruments on both grounded and metallic lines must be installed in the proper manner. Figs. 42, 44, 45, and 46 illustrate graphically the method of making the entire installation.

Before beginning work, means should be taken to determine the arrangement that will be the simplest, the most economical, and the easiest to maintain.

## 1—OUTSIDE OF BUILDING

(a) *Leading-in wires.*—If possible, the telephone should be located on the same side of the building as the pole from which the branch line originates. The wire from the line should be dead-ended on a bracket and insulator attached to the outside of the building. A line should never be attached to a building directly from a tree, and not more than 50 ft. of No. 9 iron wire should intervene between the building and the nearest pole. Set an extra pole or use insulated copper wire. Try to have the pull on the bracket attached to the side of the building parallel to the wall, and not at right angles, and always rake the bracket slightly against the pull.

The point where the wire enters the building should be as near as practicable to a permanent ground, and each ground wire should pass through the wall of the building in a separate porcelain tube, spaced at least  $2\frac{1}{2}$  ins. from the other tubes, and sloping upward from the outside. Under some conditions circular loom may be a satisfactory substitute for the porcelain tube, though it should not be used without permission from



the district inspector. Each wire as it enters the porcelain tube outside the building should have a small drip loop about 2 in. long to prevent water from following it into the building. The location of the protector in the building should be determined before the holes are made. It is often possible to locate the holes immediately above or below the fuse terminals on the protector, thus securing the shortest length for the leading-in wires.

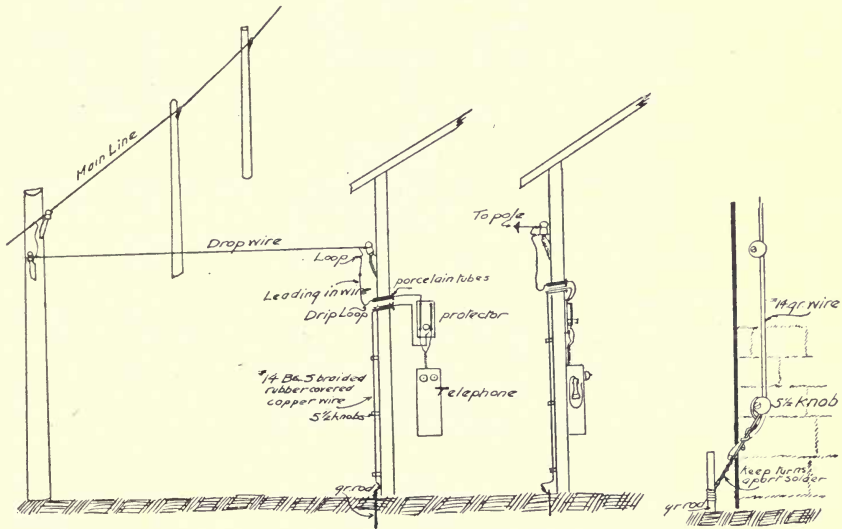

Fig. 46 Method of making entry to building from main line

The leading-in wires should not enter at the attic roof unless other ways are impracticable. In every case the holes should be started from the inside of the building.

The line terminals of the protector should be connected to the line wire by single No. 14 B. & S. gauge, braided and weather-proofed, rubber-covered, copper wire. The leading-in wire should be soldered to the loop just below the insulator where the line wire is terminated (Fig. 44), and should not come in contact with any part of the building.

(b) *Ground wires.*—Single No. 14 B. & S. gauge, rubber-covered, braided and weather-proofed, copper wire should be used to connect the protectors with the ground rod or ground wire.

Ground wire outside of the building should be supported on No. 4½ or No. 5½ porcelain knobs. The knob should always be attached with a flat-head screw, and not with a nail.

The wire from the protector to the ground should be laid as directly as possible, and should have no spirals, coils, knobs, or sharp bends. The ground wire should never be placed near sheet-iron roofing, drain-pipes, etc., on the house.

## 2—INSIDE OF BUILDING

All joints and splices of the wiring inside or outside of the building should be soldered and taped. This does not apply to the connections made at the terminals provided in the apparatus. Where a twisted pair is spliced, the joints should be soldered at least 3 in. apart. In soldering, resin should be used as a flux. Chloride of zinc, sal ammoniac, or other fluid fluxes are not satisfactory. The wires to be soldered should first be scraped thoroughly and cleaned.

All knob-and-cleat work should be done as neatly as possible. Wiring inside and outside of a building should be run in as nearly vertical and horizontal lines as

possible. This gives an appearance of neatness and simplifies tracing out the wires when hunting for trouble. There should be no knots or spirals in the wiring (this does not mean joints and splices) between the protector and the line or ground rod. The line should be kept at least 1 ft. away from the overhanging eaves if the roof is of sheet-iron. Wet and damp localities should be avoided for inside wires.

The telephone should be connected to the protector by means of No. 19 B. & S. rubber-covered and braided, single or twisted-pair copper wire. However, if this wire is not available, the heavier insulated outside wire may be used, although it is not so cheap. The wire inside the building should be fastened to the wall with insulated tacks, milonite nails, or approved cleats. Uninsulated tacks or staples should not be used. No joint in insulated wire should touch an adjacent joint in another insulated wire, even though both are taped.

(a) *Protection from pipes.*—Wherever practicable, wires should be placed *above* all pipes or other conducting material. When a crossing is necessary the wire should be protected by two wrappings of insulated tape, the latter extending at least 1 in. each side of the pipe or conducting material.

(b) *Separation from light and power lines.*—When it is necessary to cross an electric-light or power wire in the building there must be a separation of at least 6 in., unless the telephone wires are incased in a circular loom or porcelain conduit. When so incased the conduit should project at least 6 in. on each side of the electric-light or power wire and be firmly secured against slipping.

### Section 75—Lookout-station Telephone Sets

The 1336-J telephone, special forest protection type, contains a 2500-ohm unbiased ringer and condenser. The 1336-K telephone contains a 1690-ohm unbiased ringer and condenser.

An iron-box telephone set outdoors should be mounted on a post in preference to a tree or topped tree. The iron case of the box should be grounded by wrapping a wire under the head of one of the mounting bolts when the latter is screwed in and then running it to the ground rod (Fig. 49.) A switch and protector mounting-box should be attached to the post. The line wire should be properly dead-ended on a bracket and insulator located on top of the post and extended to the switch by means of No. 14 B. & S. gauge, rubber-covered, braided and weather-proofed, copper wire. This wire should then extend from the opposite side of the switch to the line terminal of the protector and from there to the proper terminal in the telephone set, through the hole in the latter provided for the purpose. The same kind of wire should extend from the ground rod to the ground terminal of the protector and to the proper terminal in the iron-box telephone, through the hole provided in the latter.

If this set is employed on a metallic circuit, a double-pole, single-throw switch should be used (Fig. 49). From each of the line wires an insulated copper wire should extend to a switch, and from the opposite terminal to its proper terminal on the protector, and thence into the iron-box set. The latter is grounded from the mounting bolt, while another wire runs from the ground terminal of the protector to the ground rod.

Installations of this character may be placed on lookout points where there is nothing but rock. The post may be bolted to the rocks and the ground rod located wherever a suitable place can be found, even though it is a considerable distance away. In this case the wire to the ground rod is run in the same manner as line wire is run. Metal brackets and fixtures may be used to support the line wire along the side of the rock, with extension bolts if required.

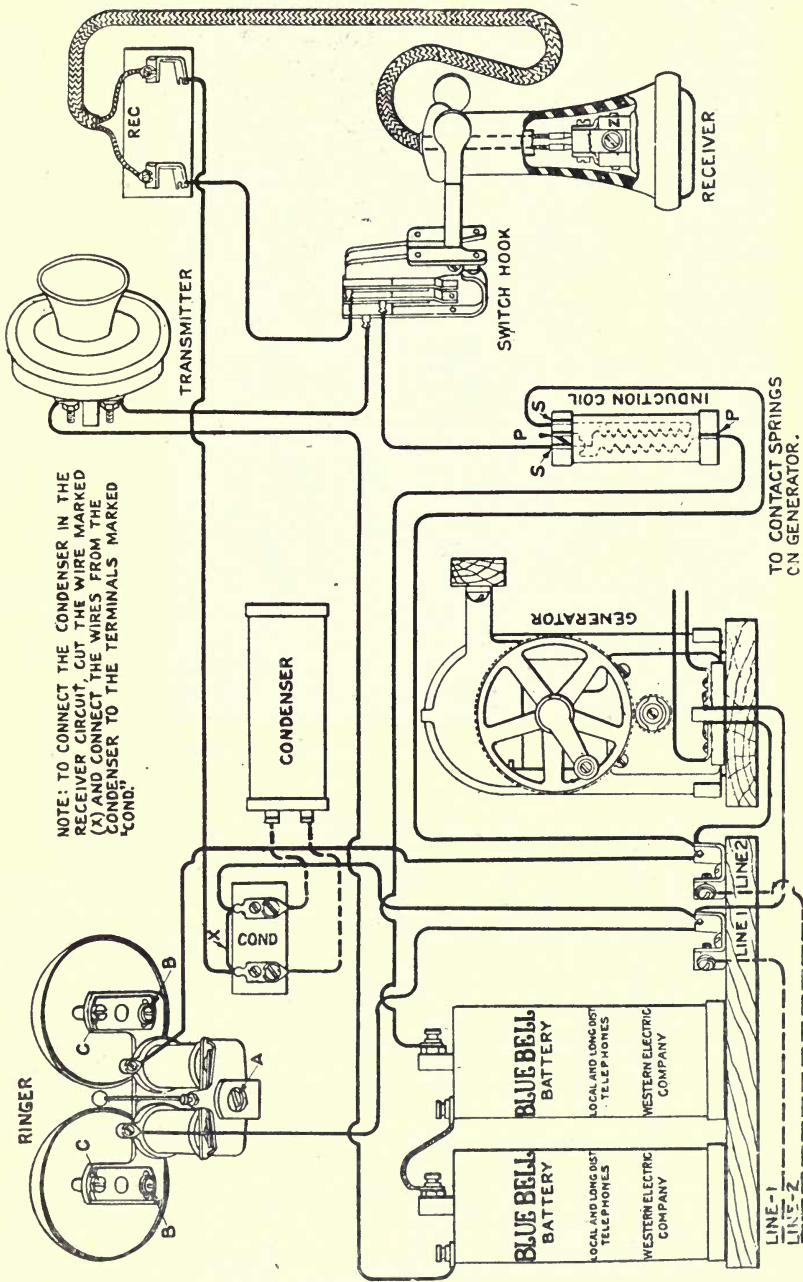

Fig. 47 Wiring diagram of lookout station telephone set

Ringer adjustment.—The armature shall be so adjusted that the clapper ball has a movement of about  $\frac{1}{16}$  inch. To obtain this turn the screw "A" to the right to shorten the stroke or to the left to lengthen the stroke. The gongs should be so set that the clapper ball strikes but does not rest against them when thrown to either side. To change the position of the gongs loosen the clamping screw "B," turn the eccentric adjusting screw "C" until the correct position is obtained and tighten up the clamping screw "B."



Fig. 48 Lookout station telephone set installed in the field

### Section 76—Howler and Condenser for Vibratory Signalling

The signals from the 1004-A portable telephone set are received at the stations by means of a howler (Fig. 82). Every station which it is desired to call directly with a portable set of this type must be equipped with a howler, but in most cases it will be found satisfactory to equip thus only the more important stations and call others by first signalling those with howlers and having them raise the desired station in the usual way by bell signals. The howler must be bridged between line and ground through a 1-microfarad condenser, except on very short lines with light loads when it may be bridged between line and ground direct. The most convenient method of wiring the howler connection is to bridge between the line and ground posts of the protector in the case of a grounded line (Fig. 50) and between the two line posts of a metallic line.

The two binding-posts on the howler will generally be found marked L and G. In making the installation run an insulated wire from the line side of the protector to one post of the condenser. From the other condenser terminal run a wire to the L post of the howler and then connect the G post of the latter to the ground or G terminal on the protector as shown in Fig 50. Do not reverse these connections on the howler as this will reduce the signalling capacity.

Howlers should all be adjusted after being permanently installed. They should never be touched, except for the purpose of adjustment, after they are once located and adjusted.

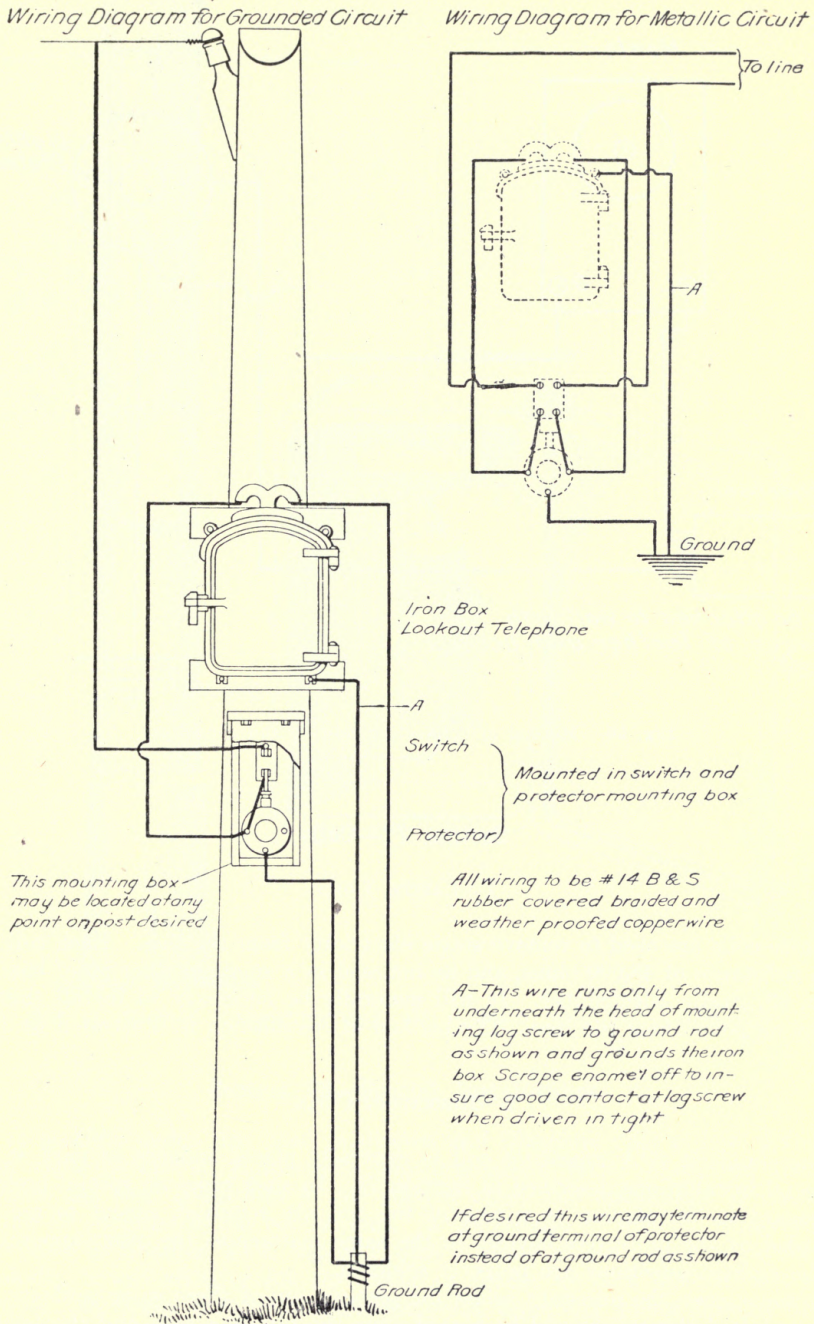

Fig. 49 Method of connecting lookout station telephone to line and ground

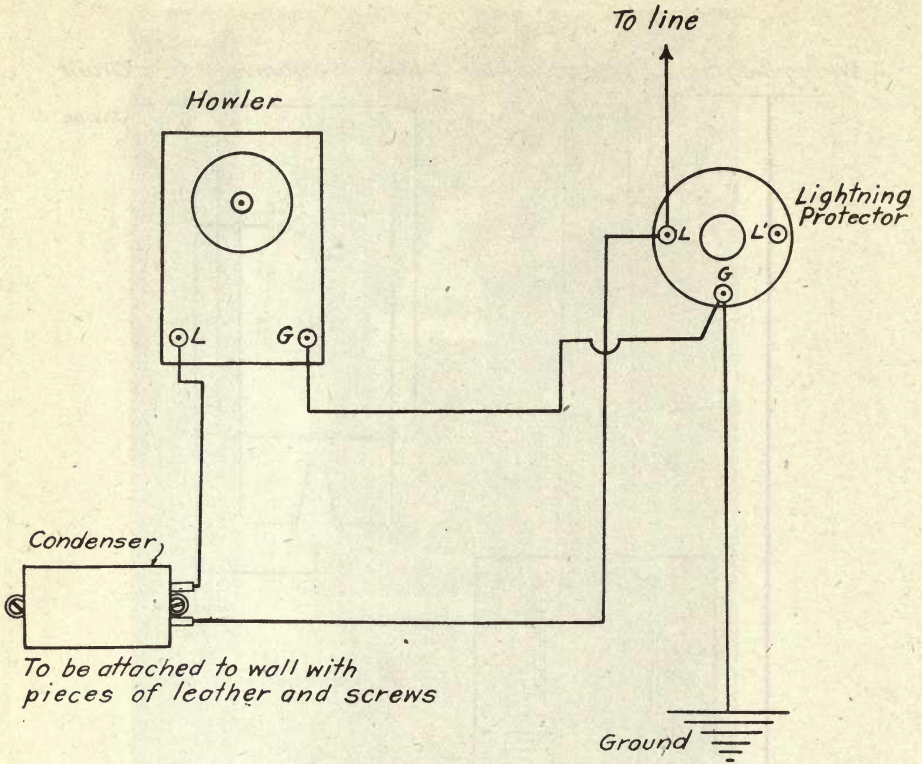

Fig. 50 Method of connecting howler and condenser

## Section 77—Coils

### 1—LAVITE COILS

These coils are used to remove static electricity from the line. Each coil should have a resistance of 48,000 ohms, and be inclosed in a small weather-proof box. (See Section 93, Static Electricity). It will generally be necessary to install these coils outdoors on poles along the line. The method of installation is illustrated by Fig. 51.

### 2—REPEATING COILS

The standard 47-A repeating coil is generally placed indoors as part of one of the special installations described in Section 78. In such cases no special precautions with regard to the placing or wiring of the coil are required, except to see that it is guarded by the protective devices in the same manner as the other apparatus and that the eight connections are properly soldered.

In some cases the necessity arises for placing one of these coils outdoors. When this is required the coil should be placed near the top of a pole and the latter may be provided with pole-steps if desired. Coils should not be installed on trees. Two protectors will usually have to be placed between the coils and the lines, and the whole inclosed in a waterproof box. The method of making such installations is fully illustrated in Fig. 52.

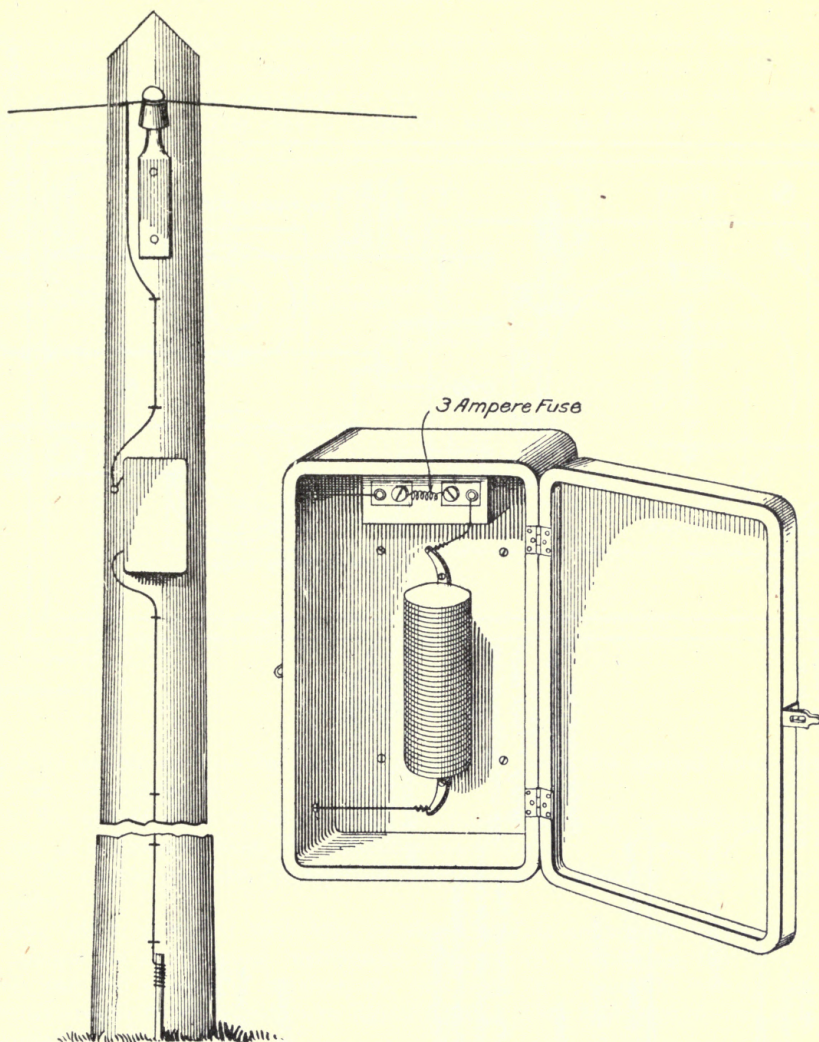

Fig. 51 Method of installing lavite coil to drain line of static electricity

### Section 78—Special Installations

It is possible under this head to discuss and illustrate only a few of the more common types of special connections encountered on forest protection lines. In many cases the local conditions at the station where the installation is made must determine the details of the connections. A knowledge of general principles such as are stated in Chapter XIV, together with a study of the reference works listed in Appendix B will often enable the officer in charge to work out the best type of connection. However, problems sometimes arise, especially where foreign lines are involved, that are highly technical in character. These should be referred to the district inspector with a full statement of all the material facts in each case.

In the following description of special installations reliance is placed largely on diagrams. Fig. 53 is the legend which shows how the various parts of the telephone equipment are graphically represented in these diagrams.

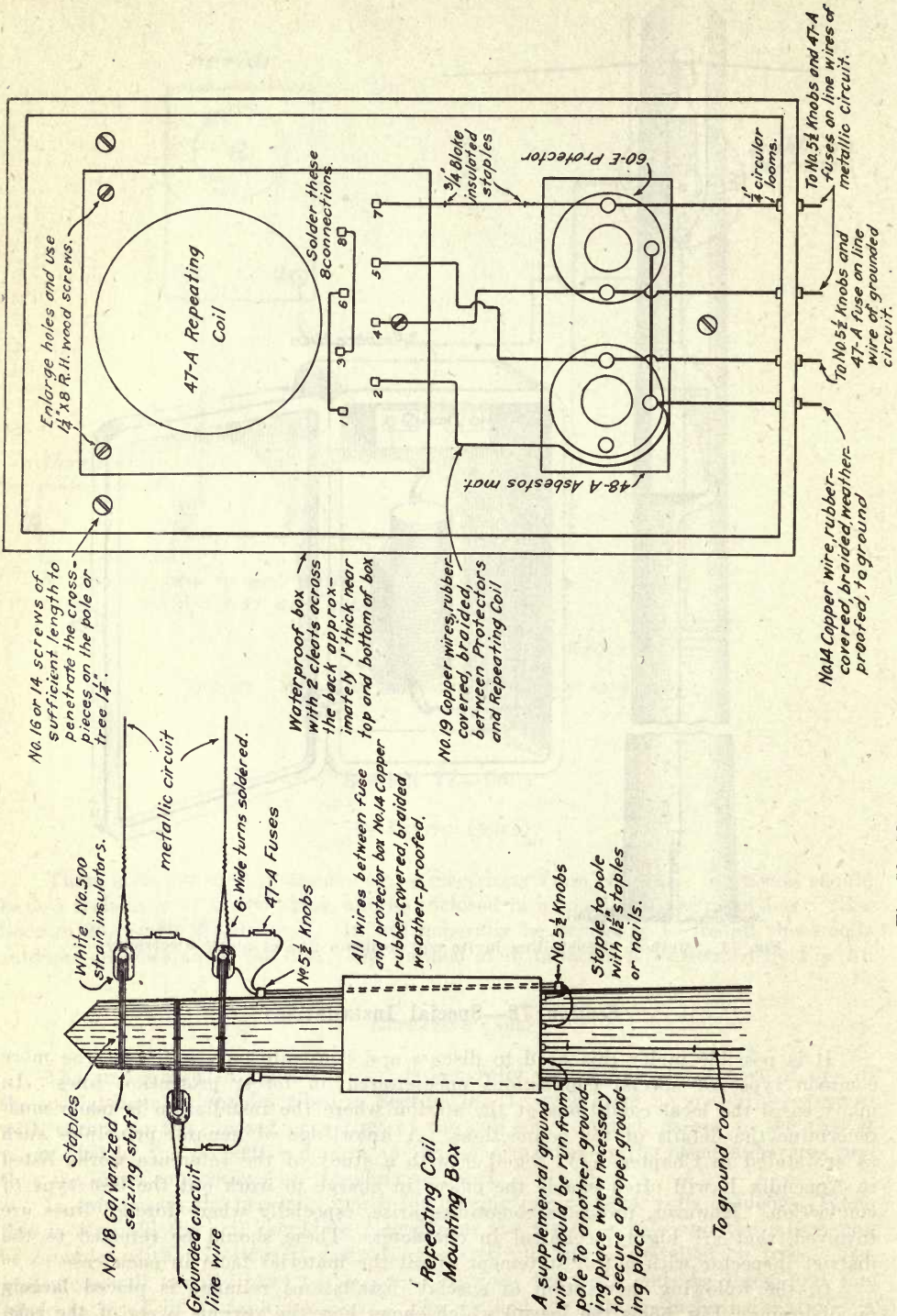

Fig. 52 Method of installing a repeating coil on a pole.



1—EXTENSION BELLS

Two types are listed as standard equipment by the Forestry Branch. These bells are simply an ordinary polarized ringer inclosed in a suitable box for mounting at any point where it is desirable to receive telephone calls but not necessary to install an instrument. The uses of extension bells are as follows:—

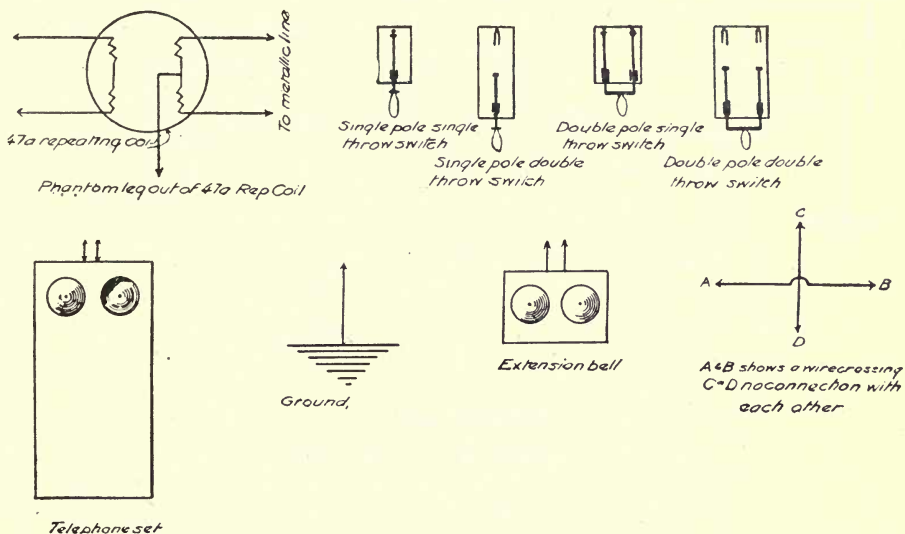

Fig. 53 Legend

(1) To enable calls to be received separately from the several lines which terminate on a switchboard.

(2) To enable calls to be received in remote parts of a building or in other buildings at a distance from the telephone instrument.

(3) To enable calls to be received outdoors at a distance from the telephone instrument.

Each bell is provided with two terminals and is connected to the line in the same manner as a telephone instrument, that is, on a bridging line it is bridged between line and ground or between the two wires of a metallic circuit. Extension bells must always be protected from lightning and other high-tension currents, as are telephones.

Extension bells with gongs of different shapes and tones may be secured and are used to make it possible to distinguish signals on different lines from each other. Where different tone bells cannot be secured, the tone may be altered by placing a wire across the gongs or by sawing a small notch in one or both gongs with a hacksaw.

2—MULTIPLE LINE SWITCHBOARDS

It is frequently necessary to install switching stations on long lines in order to keep circuits down to workable lengths. These will usually be placed where a branch makes possible the separation of three lines. The switching method shown in Fig. 54 should be used where the three lines are not connected most of the time. It requires the following equipment: Two extension bells, one telephone set, and three single-pole, single-throw, baby knife-switches. With the three lines connected, two extension bells and the telephone remain across the line.

The method shown in Fig. 55 should be used where the three lines are connected most of the time. It requires the following equipment: Three extension bells, one

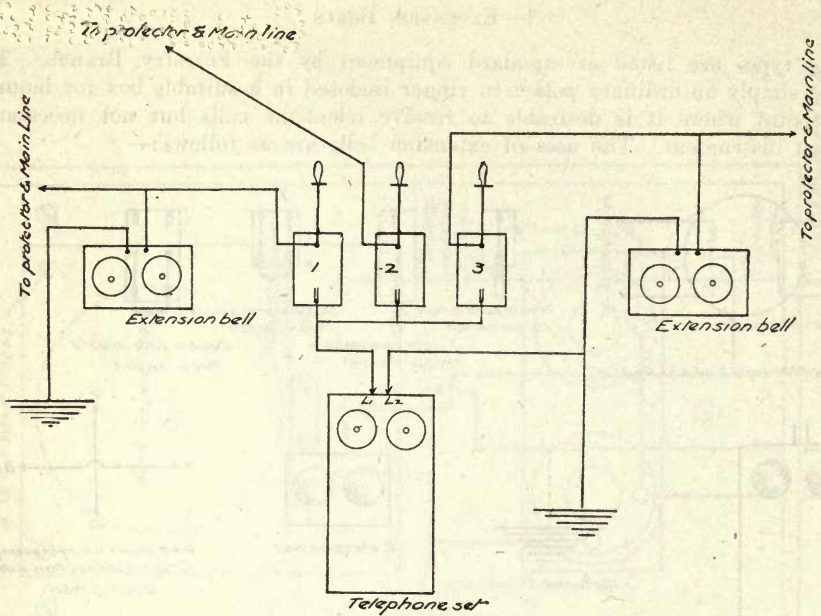

Fig. 54 Switching station, first method

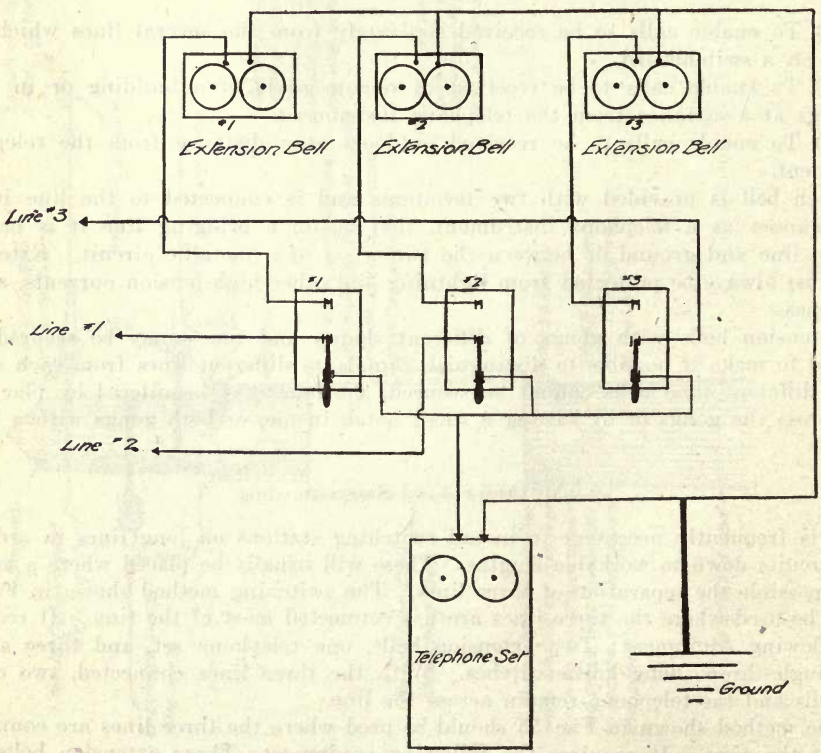

Fig. 55 Switching station, second method

telephone set, and three single-pole, double-throw, baby knife-switches. With all the three lines connected just the telephone remains across the line, the three extension bells being disconnected.

When it is desired to receive buzzer signals at a switching station, each line must be separately equipped with howler and condenser. Since it is impracticable to vary the tones of buzzers sufficiently to enable them to be distinguished readily one from another, it may be necessary to locate the various howlers in different parts of the room or building in order to be able to tell which line is calling.

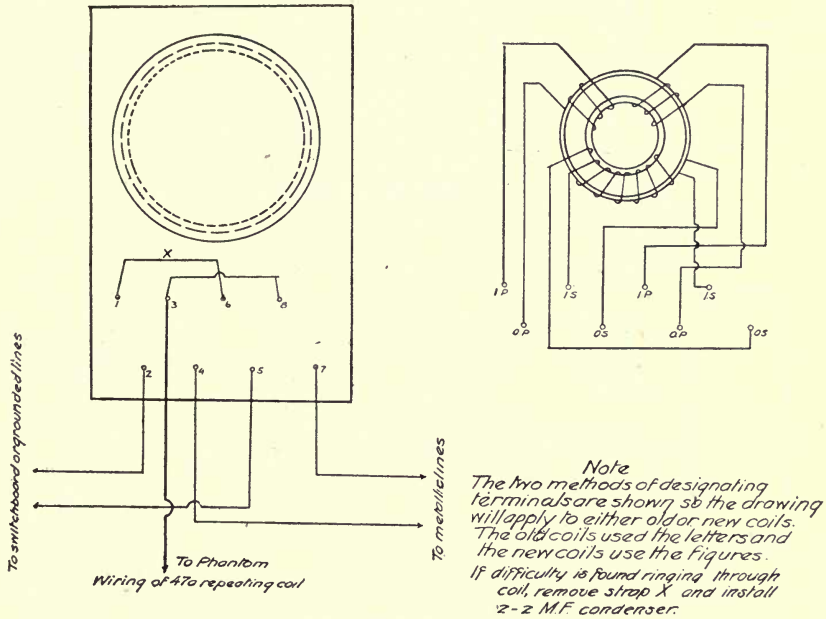

Fig. 56 Wiring and connections on 47-A repeating coil

### 3—STANDARD REPEATING COIL

The 47-A repeating coil is the most reliable and serviceable coil, both from a talking and signalling standpoint, and should be used wherever possible. This coil is also used for phantom work. By "phantom" is meant the utilizing of both sides of a metallic line as one wire. As illustrated in Figs. 57 and 87, an additional telephone circuit is thereby obtained. The repeating coil is also used whenever it becomes necessary to join a grounded to a metallic line. An 8-A repeating coil is cheaper than the above and may sometimes be used for the latter purpose.

The details of construction, and the arrangement and designation of terminals of the 47-A coil, are shown diagrammatically in Fig. 56.

### 4—PHANTOM CIRCUIT

It is possible under certain conditions to carry on two or more conversations simultaneously over the same telephone wire without interference. This is done by installing a phantom circuit, the most common type used in forest lines being a grounded phantom out of a metallic rural line.

The following equipment is necessary: Two 47-A repeating coils, one extension bell, and one double-pole, double-throw, baby knife-switch. By the method shown in Fig. 57, the Forestry Branch utilizes both wires for their line, the connection with the

Branch line being made at the end of the rural line circuit, thus eliminating the necessity of stringing an additional wire parallel to the rural line telephone circuit. By the use of the phantom circuit a direct line is obtained to the exchange or town where the rural line terminates without interfering with subscribers on the latter. The circuit is so arranged that the grounded Forestry Branch line may be cut on the metallic line direct through the 47-A repeating coil in an emergency. It is also

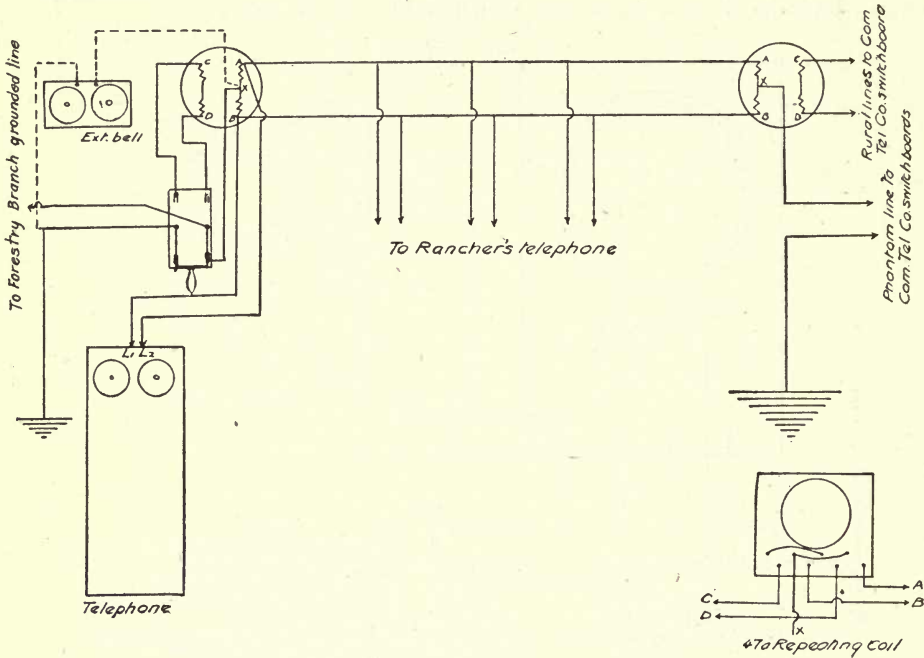

Fig. 57 Phantom circuit

arranged so that, should any of the ranchers desire to talk to one of the stations on the Forestry Branch grounded line beyond the point where the rural line terminates, by calling the station at the end of this line the switch at that point may be thrown and direct connection had. *This phantom circuit can only be built up where the metallic line does not parallel any electric-light, power, high-tension, or railway wires.*

### 5—CONNECTION OF GROUNDED TO METALLIC CIRCUIT

The necessity for making this type of connection frequently arises where the Forestry Branch lines are joined to private or provincial lines near forest reserve boundaries or at ranger stations, in order to give through service from points in the reserve to points outside. It sometimes arises, also, when Forestry Branch metallic circuits are constructed in order to eliminate inductive disturbances from power lines or other circuits in their vicinity.

A method of installing a switching station where a grounded line may be cut through to a metallic line with a 47-A repeating coil in circuit is shown in Fig. 59.

Equipment necessary: One 47-A repeating coil, two double-pole, double-throw, baby knife-switches, and one telephone set. This method is used where connection is necessary with some commercial toll line, one telephone being used on the commercial line and the other on the Forestry Branch line. If a subscriber of the commercial telephone company, or provincial line, is using the toll station, the call on the Forestry

Branch line may be answered at the same time, thus avoiding delay or interruption. When it is necessary to connect the grounded line to the metallic line, both switches should be closed, only one telephone being left across the line.

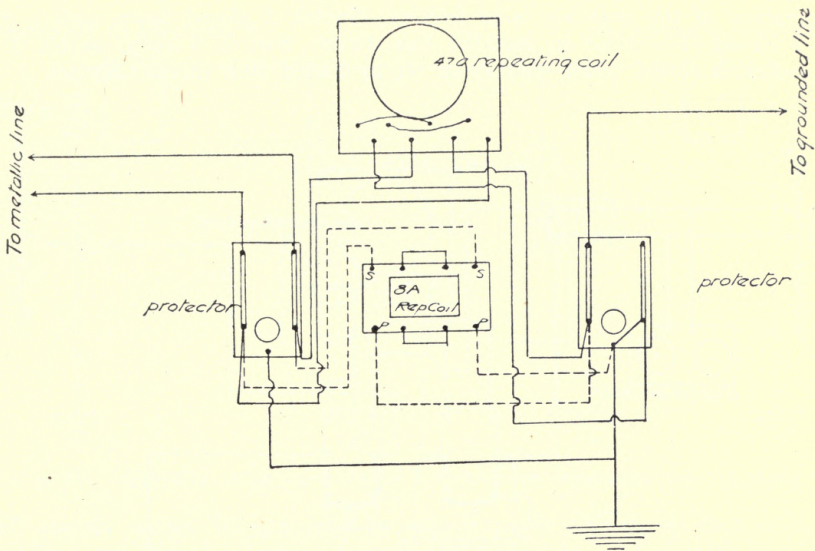

Fig. 58 Connecting grounded line to metallic line through a repeating coil without switches. Dotted lines indicate connections when an 8-A coil is used

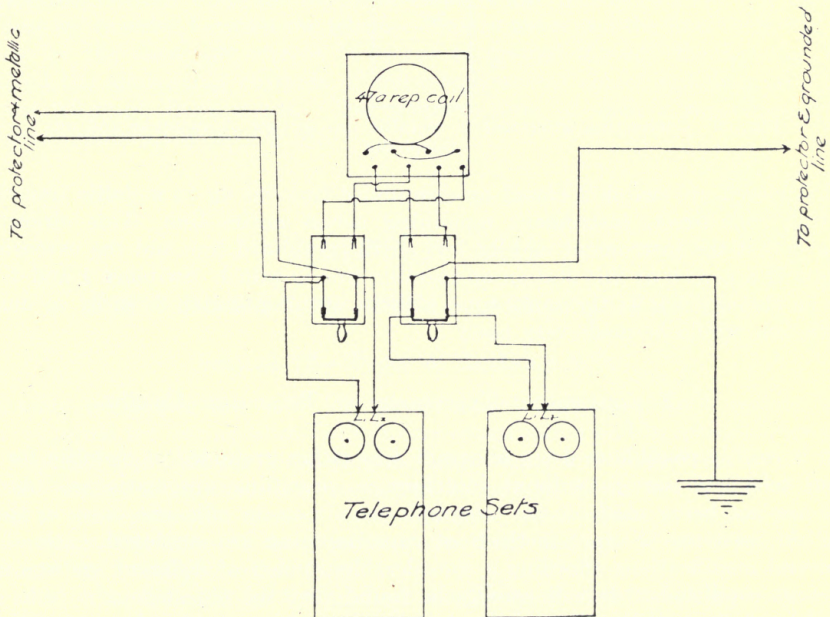

Fig. 59 Connecting grounded line to metallic line by use of switches and two telephones

A method of connecting a grounded line to a metallic line so that either can be used with the same telephone is shown in Fig. 60.

Equipment necessary: One 47-A repeating coil, two double-pole, double-throw, baby knife-switches, one double-pole, single-throw, baby knife-switch, one extension bell, and one telephone set. This circuit is arranged with one telephone and signal bell, so that a person at the station may talk on either line by using the same telephone. The operation of the switches is as follows: Switch 1 closed down, switch 2 open, switch 3 closed—telephone on metallic line direct. Switch 3 open, switch 1 closed down, switch 2 closed down—telephone on grounded line direct. Switch 3 closed,

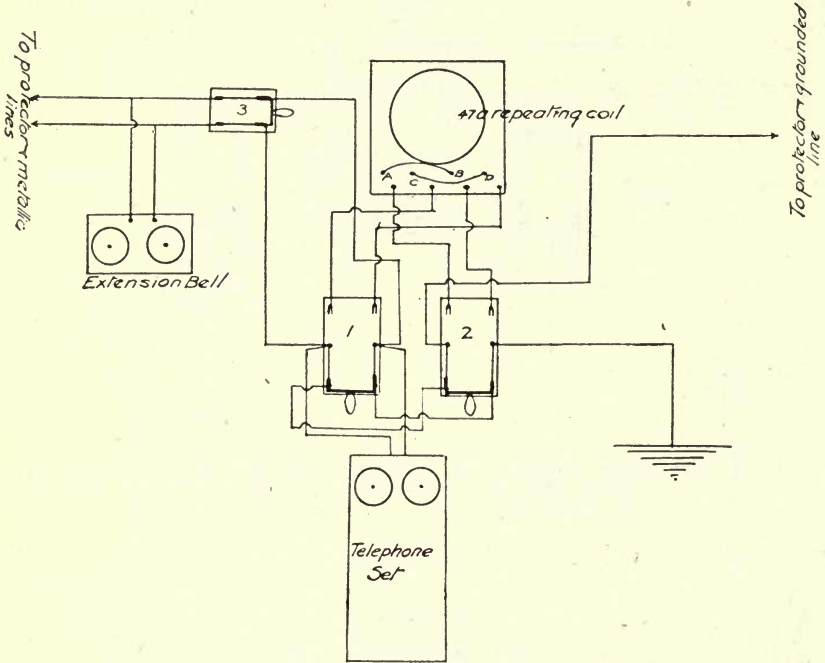

Fig. 60 Connecting grounded to metallic line by use of switches and one telephone

switch 1 closed up, switch 2 closed up—grounded line cut on to metallic line through repeating coil direct, instrument remaining across entire line. This circuit is so arranged that the instrument may be left on the grounded line and the extension bell will ring if a person at this station on metallic line is called. Switches 1 and 2 should never be closed down at the same time without opening switch 3, as by so doing the metallic line would be made very noisy.

#### 6—SUPERIMPOSING TELEPHONE ON TELEGRAPH CIRCUIT

It is readily possible to use a telegraph line either grounded or metallic for simultaneous telephone service without interference, providing automatic sending-instruments are not being used on the telegraph circuit or on adjacent ones on the same poles. At least two distinct methods of superimposing are employed, each of which has several modifications affording a considerable number of different systems adapted to various conditions. It will usually be found that the object sought is to employ an existing telegraph line for forest protection telephone service, but since the exact system that must be used will depend in each case on the arrangement and characteristics of the telegraph circuit it will be necessary that each case be referred separately to the district inspector for instructions. When reporting to the inspector state the number of telegraph wires available, whether they are operated as grounded or metallic

circuits, the number and position of all telegraph stations on the line it is proposed to use, the size and kind of wire and whether the telegraph operates by single or double current, simplex, duplex, quadruplex, or automatic.

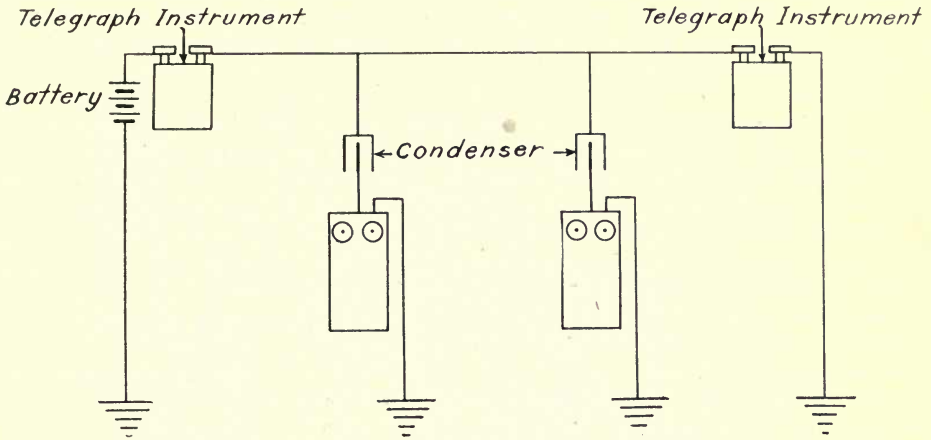

Fig. 61 Method of using one wire for simultaneous telegraphy and telephony

Bell signals cannot be employed on superimposed circuits so that most of the standard Forestry Branch telephone instruments cannot be used on such lines without modification. The 1004-A set which employs buzzer signals may be used, however.

In the majority of cases the object will probably be to superimpose a grounded telephone circuit on a grounded single-current telegraph circuit. The telegraph employs direct current while the telephone employs alternating current. If, therefore, condensers are inserted between the telephone instruments and the line, there will be no tendency for the telegraph current to escape to ground through them, while on the other hand the alternating currents of the telephone are not of sufficient strength to affect the telegraph instruments. The simplest form of such a superimposition is shown diagrammatically in Fig. 61.

## CHAPTER XIII

### INSTALLATION OF TEMPORARY EQUIPMENT

#### Section 79—Types of Portable Sets

Portable telephones are used for two principal purposes. To a certain extent they are required for testing lines, both during construction and in maintenance operations. Portable sets used for these purposes are usually known as "test sets." These are on the market in great variety, each type being adapted by the details of its construction to some particular class of work. Some of these sets are very low-priced and light in weight, but none of them meets successfully the special problems ordinarily encountered on forest protection lines.

In addition to their use for testing lines, portables are required in forest protection for establishing temporary emergency stations on or adjacent to the permanent lines of communication. The average conditions met with on forest telephone lines demand a portable set of considerable power, especially in the generator. This instrument must approximate the capabilities of the very powerful standard sets employed in the permanent stations and must be adapted for use on lines with them. Furthermore, since

it must be carried frequently on pack-horses and saddle-horses and be subjected to rough field usage it is essential that it be self-contained and well protected against external injury. Finally, light weight is important. To meet these requirements it was necessary to design an entirely new style of portable set. The 1375-A set of the Northern Electric Company was the result, and it has been adopted as standard by the Forestry Branch. No other type of test set may be purchased except with the approval of the district inspector.

The weight of the 1375-A set, however, was still found to be a handicap to its use by moving patrol, especially foot patrolmen, and a still lighter instrument was designed. This is the 1004-A set of the Northern Electric Company which weighs only 2½ pounds with battery and may be carried in the pocket. It uses the military method of vibratory signals and has been standardized for use by the Forestry Branch.

Finally, occasions sometimes arise when it becomes desirable to provide more complete telephone service at temporary stations than either of the above sets is capable of affording, but where extra light weight is not essential. As a rule this is accomplished by using a wall set, but obviously these are poorly adapted to rough methods of transportation. To meet this requirement a combination of certain standard equipment into a single set known as the Forestry Branch emergency set No. 1-A has been devised. These sets are not available for purchase but may be assembled locally or secured from the district inspector.

## Section 80—Forestry Branch Portable Telephone

### 1—USE IN FOREST PROTECTION

The special portable telephone (Northern Electric 1375-A, Fig. 62) being adapted for use on any line employing code signalling by polarized bells has a wide application in forest protection wherever its weight of 9 pounds is not a serious bar. It is more widely applicable than the Adams hand set herein described, although considerably more expensive, also. The particular advantages that this set possesses are as follows:—

(1) It is entirely self-contained in a stout leather case and capable of withstanding very rough usage.

(2) It will call by bell signals any permanent station or any temporary station provided with bells. It will also call any station equipped only with a howler.

(3) It is provided with a protector and, therefore, may be left connected to the line without fear of injury from lightning.

(4) It is provided with a buzzer and, therefore within limits, may receive a signal from a distant station.

(5) Although normally it uses only a small flash-light battery, it may, if desirable, be equipped with ordinary dry cells.

These advantages are offset only by the weight and cost of the set, and where the former is not very objectionable the set should be used.

In general, portable sets are a useful feature of the equipment of rather highly specialized forces only. They presuppose the existence of a fairly well developed system of lines of communication and of time standards, which make it imperative that these lines be available for use by the field staff regardless of the location of permanent stations. No telephone system can be provided with permanent stations so numerous that considerable time will not be required to reach them from the average point along the line. Both cost and electrical load requirements restrict the number of possible stations very materially. Wherever, therefore, the average time required to reach a permanent station in order to send an emergency message is greater than the protection standards will permit, portable sets must be made a feature of the equipment.



This set will be found particularly useful for railway-speeder patrol. It should be mounted on the speeder in a suitable box and may be connected by a switch to the ignition battery. By the exercise of a little ingenuity a speeder may be equipped for almost instant communication from any point along the line, and fire may be at once reported without the necessity of running to the nearest station.

The set is also well adapted to all sorts of repair and construction work and where travel is largely by team, as in many of the reserves of the Prairie Provinces,

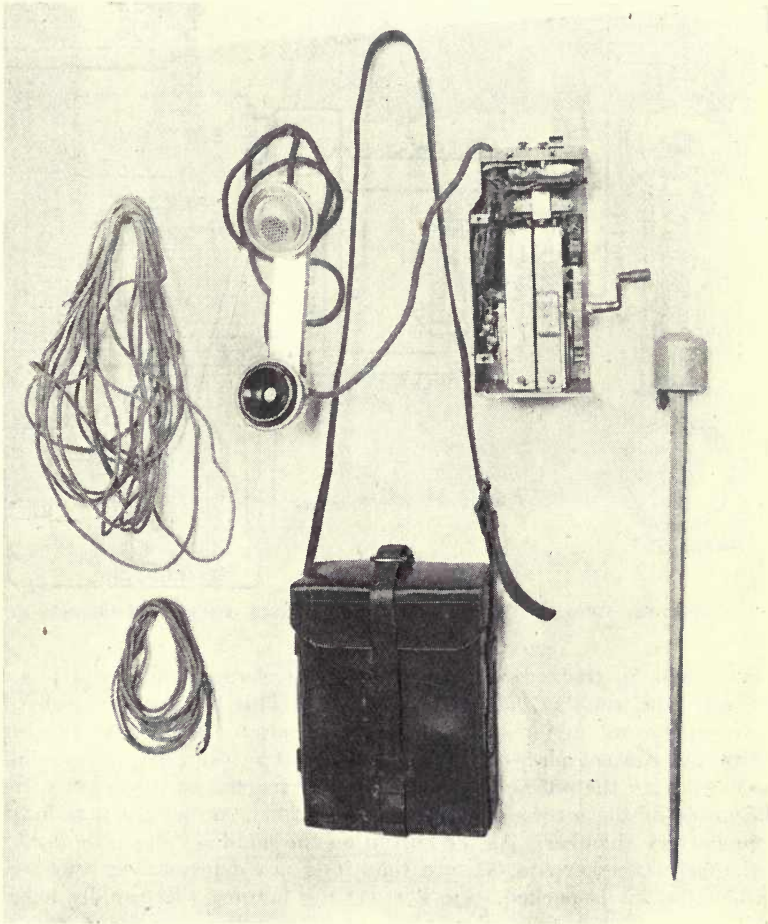

Fig. 62 Forestry Branch portable telephone set (1375-A) with ground rod and connector

it will be found superior to any other for general use by forest officers. It is not, however, well adapted to either foot, horse, or canoe patrol, but may be employed on motor boats.

## 2—CHARACTERISTICS OF 1375-A SET

The weight of the set is 9 pounds and the outside dimensions  $3\frac{1}{2}$  in. by  $6\frac{1}{2}$  in. by 9 in. It is contained in a sole-leather case and provided with an adjustable shoulder-strap. The interior contains an aluminium angle-plate to which is attached all the equipment except the receiver, transmitter, and switch. These are combined in a very light, compact, aluminium hand set. The angle-plate is itself fastened to the leather

case by screws. A wooden block on top bears the two binding-post connections and a spring clip in which the detachable generator crank is carried. Inside the lid of the leather case is a diagram of the connection (Fig. 63). The hand set is carried in a small compartment alongside the rest of the essential apparatus and is connected permanently to the set by a stout receiver cord. A small, black button at the receiver end must be pressed while using the set for talking or listening. This takes the place

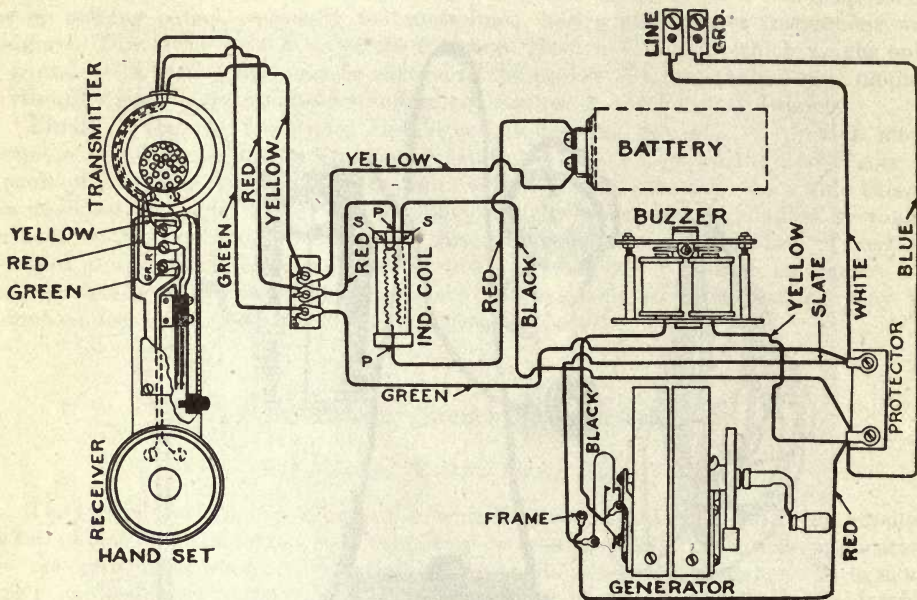

Fig. 63 Wiring diagram of Forestry Branch portable telephone

of the switch-hook in the ordinary telephone. The battery employed is a three-cell, flat, flash-light type, such as the 703 Ever Ready. This battery is inserted by removing the two top screws on the side bearing the generator crank and shoving the battery in with the contact plates foremost. When it is desirable to use the ordinary type of dry cell with the set, one or two may be connected by insulated wires attached under the heads of the screws that fasten the battery contact springs located in the back of the battery chamber. As the button on the hand set closes the battery circuit it is particularly necessary to be sure that it is not depressed by the receiver cord or case when the set is packed, as otherwise the battery will rapidly exhaust itself. The hand set is of very light aluminium and must be carefully protected against injury. Dents near the switch may make contacts that reduce or destroy the efficiency of the instrument.

## Section 81—Adams Hand Set

### 1—USE IN FOREST PROTECTION

The necessities of the more highly specialized forest protection forces demand a type of instrument that may be available to every member of the field staff, regardless of the transport facilities employed. Experience has demonstrated that only an instrument that may reasonably be described as a pocket type will meet these requirements. When it is remembered that some of the more perfectly organized forces require hourly

reports from the field force throughout the danger season, this need will be readily appreciated. It has been successfully met by the invention of the Adams hand set (Northern Electric 1004-A, Figs. 64 and 66).

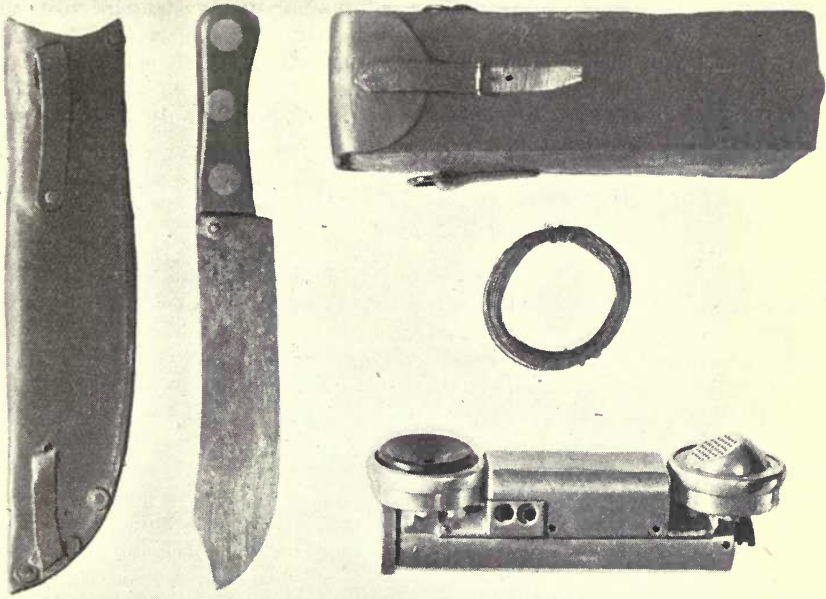

Fig. 64 Adams hand set (1004-A) with carrying case and connector and grounding knife

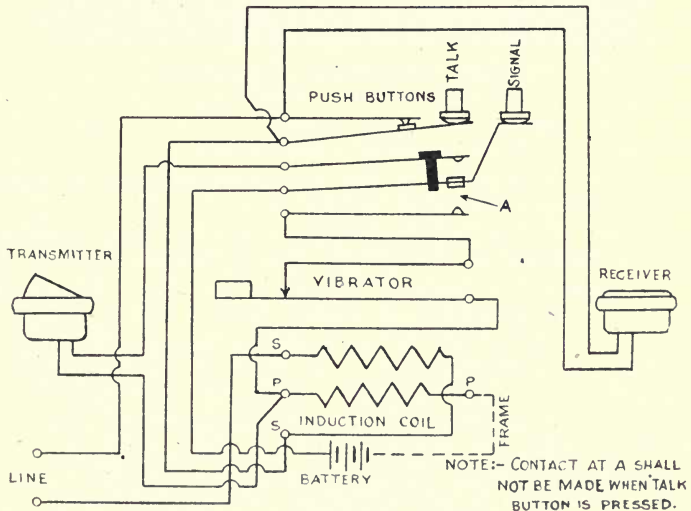

Fig. 65. Wiring diagram of the Adams hand set (1004-A)

This hand set is so small and light that it is as conveniently carried as a fair-sized field-glass. In addition it is considerably less costly than the Forestry Branch

portable telephone and compares favourably in this respect with the low-priced test sets. Its advantages, however, are almost wholly those of weight and price, but both are so considerably in its favour that it has a very wide application in specialized forest protection.

The disadvantages of this set are as follows:—

(1) It cannot be used to call a station equipped with the standard instruments, unless an auxiliary signalling device is installed.

(2) It has no protective equipment and cannot safely be left connected to a line when not in use.

(3) No means are provided by which a station equipped only with this set can receive a call. Auxiliary apparatus must be available.

## 2—CHARACTERISTICS OF THE 1004-A SET

The weight of the set is  $2\frac{1}{2}$  pounds and the length over all is  $9\frac{1}{2}$  in. This set eliminates entirely the heavy, alternating-current generator needed for ringing the ordinary type of polarized bell by substituting an entirely different system of signalling, and thereby greatly reduces the necessary weight. Transmitter and receiver are the same as with the portable telephone and a larger, three-cell, cylindrical, flash-light battery is employed. A switch with two push-buttons is provided. One of these is pressed for signalling, the other while talking and listening. The novel feature of this set is the induction coil, which, besides serving the usual purpose in speech transmission, also serves to produce a very rapidly alternating current, used in signalling in place of the generator and bells. This is accomplished by equipping the coil with a vibrator which makes and breaks a contact in the primary of the induction coil.

The whole apparatus is inclosed in a special aluminium case and equipped with two binding-posts at one end for connection to the line and ground. The proper connections are designated L and G, respectively, on the sides of the instrument near the binding-posts, and it is important that the line and ground wires be attached to the right posts, as otherwise the efficiency of signalling is reduced.

Calls are made by a system of long and short buzzes. These are produced by depressing the button marked "Signal." After signalling, the "Talk" button is depressed to use the instrument for conversation. Long conversations with the portable must be avoided as the longer the conversation, the greater the drain on the battery. The batteries should last with ordinary usage six or eight weeks and care should be taken to see that fresh ones are secured for renewals. The Ever Ready Tungsten No. 705 is the type employed. When inserting a new battery in the battery chamber it is necessary to put the top of the battery in first, so that the spring of the battery chamber cap has the broad surface of the bottom to bear on.

The signals from this set are received by a howler. The installation of this apparatus has been described in Section 76. The instrument itself is described in Section 86. The presence of a number of howlers on the line is objectionable for not only do they produce a disagreeable noise when a signal is sent in either by generator or vibrator, but all conversation on the line is audible in any room where a howler is placed. Howlers should be installed only at the principal switching centres or at such stations as are most continuously occupied. Ordinarily they should be at least 30 miles apart and may be at greater distances. Any station not equipped with a howler may be called with the usual bell signals through one of these switching centres.

In using the Adams hand set it is necessary to keep in mind that it is entirely unprovided with a protector and, also, that when it is connected to the line it acts as a direct ground. It should, therefore, not be left connected to any line when not in use, as it would not only be exposed to serious injury from lightning but would prevent other stations from ringing past it. It should also be noted that the sound of the vibrator when received in an ordinary receiver over lines of ordinary length is not

only painful but might be dangerous to the ear. Special precautions must always be taken to make sure that the line is not in use before attempting to call a station with this hand set.

The aluminium case is thin, and dents or other injuries which it might receive from rough handling can easily form contacts that may destroy the usefulness of the set. These must be carefully avoided and the sets must always be transported in the leather cases furnished with them. These cases are made large enough to hold the necessary connectors and a folding ground rod.



Fig. 66 Forest officer preparing to use the Adams hand set with Cree knife for ground rod

### 3—BUZZER SIGNALLING

The vibratory currents produced by the Adams hand set are of very high-tension and will traverse lines that are in such poor condition that bell signals will not pass over them. It is therefore feasible, when lines for any reason are in extremely poor condition, to call stations with this set at much greater distances than with the bells. It is even possible to signal across breaks in the wire providing the ends of the broken wire make a good ground contact, preferably with moist earth. In this case, however, signals cannot be heard in the howler but can only be heard in a receiver held to the ear, which restricts the practical utility of this capacity to those few forests that maintain permanent telephone operators with head receivers. Tests have shown that signals are plainly transmitted across a 65-ft. gap and may be distinguished very faintly across a 210-ft. gap. They will also traverse miles of bare iron wire lying on the ground, even in wet weather, and at a distance of one mile may be heard in the howler. The sound produced in an ordinary receiver at a distance of 50 miles over very poor lines can be heard several rods away. At a distance of 200 miles over lines too poor for transmission of speech, signals are plainly audible in the receiver when held to the ear, and weakly audible in the howler.

This capacity for very long distance transmission over poorly insulated or even broken lines makes it feasible to consider the set as a possible auxiliary communication device for sending telegraph messages, even when the lines will not carry telephone messages. This buzzer telegraphy is the most common method employed for military communication over field cable and other insulated-wire lines laid on the ground. The International Morse code is used and dots and dashes are represented by short and long buzzes. The Adams hand set would require some modification if used in this way to any considerable extent, but there are possibilities for utilizing it in emergencies wherever the protection forces have the requisite training and organization.

It is also to be noted that the buzzer signals of this set may be transmitted simultaneously with ordinary Morse signals over one wire (see Section 78).

## Section 82—Emergency Communication Kits

### 1—USE IN FOREST PROTECTION

It frequently happens that temporary telephone stations must be established in the field, as at fire-camps and other camps where messages must be received as well as sent. The Adams hand set alone cannot receive a call, while the sound of the

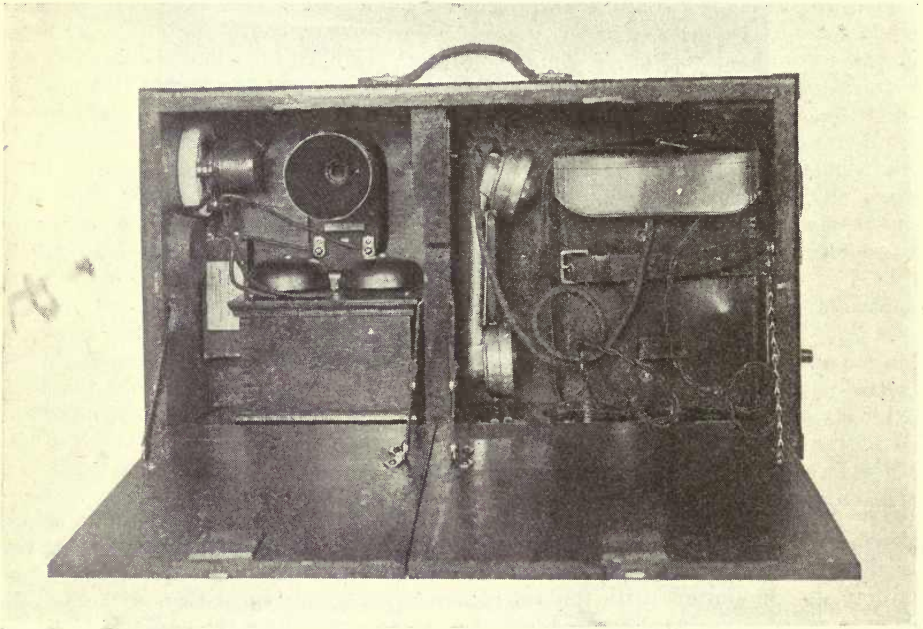

Fig. 67 Forestry Branch emergency communication kit No. 1-A

buzzer in the Forestry Branch portable telephone is inaudible at a few yards. Either a howler or an extension bell must be provided where signals are to be received. Communication kits comprising the necessary instruments for two stations with emergency wire and tools for stringing it, all packed into suitable cases for pack or wagon transport, are employed by certain protective organizations. A somewhat similar kit comprising the instruments above mentioned has been devised for Forestry Branch use. It is only necessary to add a case of emergency wire and a reel to this kit to have a full emergency outfit.

2—CHARACTERISTICS OF THE 1-A SET

The purpose of this set is to afford a field instrument that is self-contained, will stand rough usage, receive both buzzer and bell signals, and be available for use with either of the two standard portable telephones. In addition, space is secured for the grounding and connecting devices, extra battery, and some small installation tools.

The 1-A set is a shallow wooden box divided into two compartments of unequal size. In the smaller compartment is mounted the following standard equipment: 1 extension bell, 1 protector, 1 howler, 1 condenser.

The larger compartment is fitted with two binding-posts, from which wires lead to the external connections on the set as shown in Fig. 68.

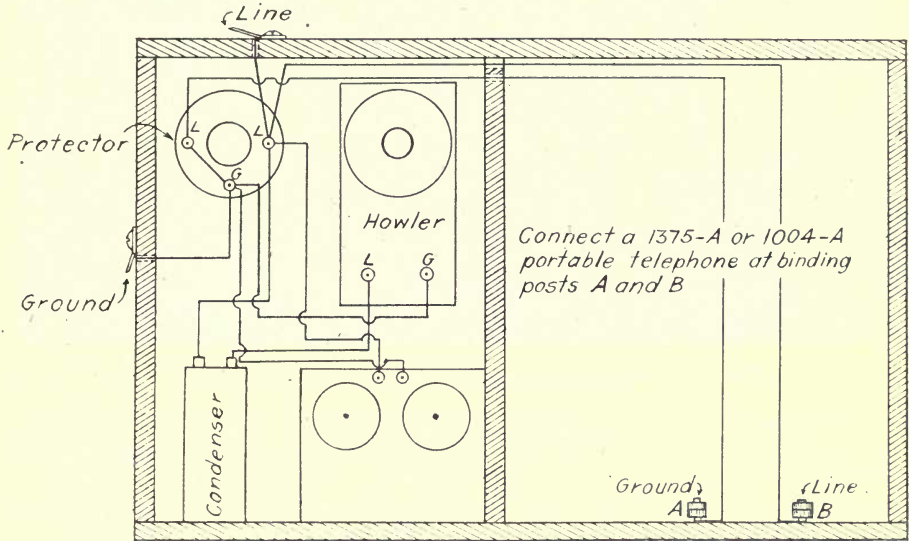

Fig. 68 Wiring diagram of the No. 1-A kit

It is arranged so that either the 1004-A or the 1375-A portable telephone may be placed in it, connection being made to the above-mentioned binding-posts. Plenty of space is left in this compartment for tools, connectors, etc., and a suitable holder provided for the ground rod. On the top and ends strong leather handles are attached by which it may be lashed to a tree or other support as shown in Fig. 69.

This set weighs 26 pounds complete with all equipment, including the 1375-A telephone. With the 1004-A set it weighs 19½ pounds. It may be placed on a table or other suitable support if used indoors. The doors open downward and serve as a writing shelf.

Section 83—Temporary Connections to Permanent Lines

The method of connecting emergency wire to permanent lines has been described in Section 62. It frequently becomes necessary to make rapid connection with overhead wires from the ground. Such connection must be made, for instance, when cutting in on the line with any of the portable telephones previously described, and it is essential that both connection and disconnection be made quickly without the necessity for climbing poles or trees. To accomplish this some special apparatus has been devised.

1—EMERGENCY CONNECTORS

The type adopted by the Forestry Branch consists of two pieces of No. 18 stranded, insulated wire, one of which is 25 ft. long and the other 8 ft. The former is provided 79211—8½

with a flat, brass hook at one end and a cord terminal at the other. The latter has a cord terminal at each end. The total weight is 10 ounces.

For use with the Adams hand set a similar connector may be made in the field of emergency wire. A brass hook is easily improvised from the contact plates of a worn-out 703 Ever Ready battery.



Fig. 69 Forest ranger using the No. 1-A emergency kit

The emergency connector, Northern Electric No. 311-D, used on some reserves, is not as suitable as the new type, and this connector is no longer a part of the standard equipment.

## 2—METHOD OF USE

The No. 311-D connector is joined to the overhead wire by throwing one end over and then pulling it along the wire until a contact is made at the bare place in the centre of the connector. The two ends are both joined to the line terminal of the set marked L. The short wire is then used to join the ground terminal marked G to the ground rod.

The standard connector is attached to the overhead wire by means of a short pole. Generally, any light pole about 10 or 12 ft. long, cut as needed, is sufficient. To the tip the end of the connector bearing the hook is attached, so that the hook projects a few inches above the pole and the rest of the connector is wound around the pole in a long spiral. It is then hooked over the wire and allowed to swing loose, the weight of the pole serving to ensure a good contact. The end bearing the cord terminal is joined to the line post of the instrument, the short wire connects the ground post to the ground rod. The whole operation is performed in a couple of minutes. With metallic circuits two connectors must be used, but the ground wire is unnecessary.

## 3—TEMPORARY GROUNDS

The importance of extreme care in locating permanent grounds has already been emphasized. Far less care is required for a temporary ground connection. Although it is true that except in very dry regions, or in the winter in the north, a workable ground for a temporary connection can be obtained almost anywhere, yet it is always



best to let the grounding facilities determine the place of connection if possible. The best place is the margin of a stream, pond, or slough, where the ground rod may be set in the wet soil or mud. Do not try to ground in water alone, or in a rocky bottom. If a natural wet place is not convenient, ground in loose, moist soil and after setting the ground rod pour a pail of water over it

The special portable ground rod, Northern Electric No. 313-B, usually known as the bayonet ground rod (Fig. 62), is useful with emergency kits, but for use by patrolmen with portable telephones it should be replaced by a large hunting-knife. The bayonet rod is a singularly useless instrument except for its one special purpose, and when weight is an important consideration, as with patrolmen or "smoke chasers," the hunting-knife is preferable. A fairly large blade is necessary in order to make a good ground. At the base of the blade close up against the handle a brass binding-post should be inserted and soldered to the blade. The Cree knife shown in Figs. 64 and 66 has a blade 9 in. long by 2 in. wide and serves admirably for grounding a portable telephone, but a smaller knife may be used. Very good ground rods can be made of heavy jointed brass rifle cleaning rods, and these may be carried in the case of either of the portable telephones. It is probable that the need for a satisfactory portable ground will result in development in this direction.

## CHAPTER XIV

### MAGNETO TELEPHONE

#### Section 84—Introduction

It is a matter of common knowledge that the purpose of the telephone is to enable conversation to be carried on between two persons who are beyond ordinary talking distance from each other, and that this is accomplished by converting the air vibrations of the voice into electrical vibrations which are carried to the distant person over a wire or electrical conductor and there converted into air vibrations or sounds of the same character. The modern commercial instruments have been brought to such a high state of perfection and are so nearly "foolproof" that it is possible for persons entirely without knowledge of the principles on which these instruments operate to install and use them with entire success by observing a few simple precautions, following directions, and using plain common sense. It is very desirable, however, that those who have charge of extended telephone systems, such as are now commonly used in specialized forest protection, should have some understanding of the fundamentals of the telephone. Unfortunately, to understand the operation of this instrument requires some knowledge of practically every branch of electrical science, because nearly every branch is to some extent utilized in the modern telephone. For the benefit of those desiring a full understanding of this instrument a comprehensive list of books of reference has been inserted in Appendix B.

The description of the telephone instrument contained in this manual is intended for those who have little or no knowledge of the science of telephony, and should be regarded only as an introduction to this science.

It is necessary, however, to assume the possession of a knowledge of the fundamental electrical phenomena. Those unacquainted with even the elementary facts of electrical science will first have to consult some standard text book on the subject. Certain definitions, however, of technical terms most frequently employed in the science of telephony may assist in an understanding of the text, and are therefore included in this manual.

## Section 85—Definition of Electrical Terms

(a) *Voltaic Cell*.—A voltaic cell is an arrangement of two electro-chemically different solids in a liquid which will attack one of them more actively than the other. This liquid is called the electrolyte and is generally an acid. One of the solids is nearly always zinc. Carbon is very commonly the other. Dry voltaic cells usually consist of a zinc cup containing a carbon plate and an absorbent porous substance saturated with the liquid electrolyte. This cup is sealed with wax or asphaltum. Dry cells are now commonly employed to furnish the current for the transmission of speech by telephone. Inert dry cells that contain all the necessary elements except water may be obtained. They are entirely inactive until water is added and keep indefinitely, while the ordinary type deteriorates rapidly even though not in use.

(b) *Conductor*.—Any substance through which electricity flows readily is called a conductor. Most metals are good conductors. In conductivity, copper is surpassed only by silver and is followed by aluminium, zinc, iron, tin, lead, and carbon in the order named. Iron has only about one-sixth the conductivity of copper.

(c) *Insulator*.—Any substance through which electricity will not flow readily is termed an insulator. "Non-conductor" or "dielectric" are other terms having the same meaning. Among common insulators are ebonite, glass, resins, paper, paraffin, porcelain, mica, rubber, and dry air. "Conductor" and "insulator" are, however, relative terms. No substance is an absolute insulator and all substances oppose some resistance to the flow of electricity, so that no substance is a perfect conductor.

(d) *Circuit and Grounded Circuit*.—The entire path along which electricity flows is called a circuit. It comprises the voltaic cell or cells called a battery or some other device, such as a generator, for producing electrical pressure, and the wire or other conductor connecting the battery plates or the ends of the generator coils. Bringing the two extremities of the wire in contact and separating them are called, respectively, *closing* and *opening*, or *making* and *breaking*, the circuit. A complete *metallic* circuit is unnecessary, it being possible to use the earth itself as a return path for the current. It acts more like a great reservoir of electricity than as a conductor. A circuit, part of which consists of the earth, instead of being a complete metallic path, is called a grounded circuit.

(e) *Magnet*.—A magnet is a piece of iron or steel (generally a bar) which has the property of attracting other pieces of iron or steel. If freely suspended at its centre it will point north and south. It can impart these properties to another piece of iron or steel without losing any of its own. These powers may also be imparted to a piece of iron or steel by passing an electric current through an insulated wire wound around the iron or steel. Steel will retain these magnetic properties; very soft iron will retain practically none. An iron magnet thus produced is called an electro-magnet.

(f) *Electro-motive Force—The Volt*.—That *force* which maintains or tends to maintain a current of electricity through a conductor is called electro-motive force. The abbreviation for this term is E.M.F. Electro-motive force is, in effect, electrical *pressure* and is analogous to the "head" or pressure which maintains a flow of water through a pipe from one vessel to another at a lower level. Electricity flows in a conductor only when there is a difference of such electrical pressure or difference of "potential" between its own ends. Such a difference may be maintained by a voltaic cell or by a generator. It is this difference of pressure which sets up a current in the conductor, and as long as it is maintained the current will continue to flow. The unit of E.M.F. is the *volt*, for practical purposes, about the E.M.F. of a Daniell's cell, i.e., it is *about* the difference of potential between the zinc and copper plates of this cell.

(g) *Resistance—The Ohm.*—The opposition offered by any substance to the flow of the electric current through it is known as *resistance*. Different substances oppose the flow of electricity in different degrees, copper being one that opposes a very low resistance (see Conductor). Insulators oppose an immensely powerful resistance. With any given conductor, increase in length causes increase in resistance; increase in cross sectional area causes decrease in resistance; and, for most conductors, rise in temperature causes increase in resistance. For any one conductor, resistance is, in a way, analogous to the frictional resistance offered to the flow of water through a pipe. Electro-motive force tends to maintain a flow of electricity against the electrical resistance of a conductor just as a “head” of water tends to maintain a flow of water against the frictional resistance of a pipe. The unit of electrical resistance is the *ohm*. Conductivity is the opposite of resistance.

(h) *Current Strength—The Ampere.*—The rate of flow of electricity is termed its current strength. It is the result of E.M.F. acting through a conductor and overcoming resistance, and is measured in *amperes*. The ampere, or unit of current strength, is analogous to the “miner’s inch” used in the measurement of the flow of water. Obviously the three factors, *E.M.F.*, *resistance*, and *current* are interdependent. Their relation to one another is stated in Ohm’s Law thus:—

The Current is equal to the Electro-motive force divided by the Resistance, or

$$C = \frac{E}{R}$$

(i) *Electro-magnetic Induction.*—Every magnet and every current-bearing wire is surrounded by a *magnetic field* having among other properties that of being able to induce magnetism in a piece of iron or steel placed within it, and of being able to produce a difference of potential between the ends of a wire moved across such a magnetic field in such a way as to cut its lines of force. If the ends of this wire are connected outside the magnetic field, a current will flow as long as motion is maintained. Such currents are called *induced currents* and the process by which they are produced is called *electro-magnetic induction*.

(j) *Induction Coil.*—An induction coil is a device consisting of two distinct coils of insulated wire, one placed around the other, but not electrically connected, by means of which, as a rule, currents of low potential and high amperage are changed to a high potential and low amperage, or vice versa. One of the coils, usually having an iron core, is used to produce the magnetic field by means of a current from a battery to which it is connected. This is called the *primary*. The other coil, generally above the primary or around it, is called the *secondary*. Currents may be produced in the secondary by means of any of the following methods:—

- (1) By moving either the primary or the secondary while a current is flowing in the primary, thereby altering the position of the coils with respect to each other.
- (2) By making or breaking the primary circuit.
- (3) By altering the current in the primary.
- (4) By reversing the direction of current in the primary.
- (5) By moving the iron core while current flows in the primary, thereby altering the magnetic field.

Any one of these operations causes a disturbance in the magnetic field as a result of which currents are induced in the secondary.

In the induction coil, as usually employed, either alternating or interrupted currents in the primary induce currents in the secondary whose E.M.F. bears the same relation to the E.M.F. of the primary current as the number of the turns of wire in the secondary coil bears to the number of turns in the primary. For example, if there

are 10 turns in the primary and 100 turns in the secondary and a current of 1 ampere at 10 volts pressure is passed through the primary, then the current induced in the secondary will have a pressure of 100 volts but a current strength of only 0.1 of an ampere. This principle is made use of in telephone transmission, in induction telegraphy, and in wireless.

(k) *Electro-magnetic Generator*.—The electro-magnetic generator is a device by which induced currents are produced continuously and made to flow through an exterior closed circuit. The dynamo generator consists of a magnet to produce a magnetic field, and a coil of wire wound on an iron core, which latter part is called the *armature*. The armature is that part of the circuit in which the induced current is generated. If moved in the magnetic field of the magnet in such a way as to cut its lines of force, a current is produced by induction, and if the motion of the armature is continuous the current that results is continuous also. Electro-magnets are usually employed to produce a magnetic field but in some small generators permanent steel magnets are used. Such generators are called *magnetos* and being extensively used in certain types of telephones have given rise to the term “magneto telephone.”

(l) *Direct Current and Alternating Current*.—The electric current among its other properties has *direction*. This has already been indicated in referring to the production of induced currents as in an induction coil. A current which moves continuously in one direction only is called a *direct current*. Such a current is that which flows from the carbon pole to the zinc pole of a voltaic cell when these are connected by means of a conducting material, such as a piece of copper wire. The current used in ordinary telegraphy is a direct current. As contrasted with this form of current we have that which is constantly changing in direction, flowing first in one direction and then reversing and flowing in the other. This is known as an *alternating current* and is produced by many forms of dynamo generators and in the secondary of an induction coil. Alternating currents are especially important in telephone work as both the talking currents and those which operate the common type of polarized bell are of this character. So also, is the current which actuates the howler used in vibratory signalling.

(m) *Frequency*.—This term is used to designate the rate of reversal of direction of alternating currents. *High-frequency* currents are alternating currents that reverse direction very rapidly, while *low-frequency* currents reverse comparatively slowly.

(n) *Tension*.—This term as applied to electricity has the same meaning as potential difference or E.M.F. High-tension currents are those of high voltage or E.M.F.

(o) *Electro-static Induction*.—An insulated conductor, such as a sheet of tin-foil, has the property of receiving a charge of static electricity when subjected to an E.M.F., as, for instance, if it is connected to one pole of a cell, the other pole being connected to the ground. The charge that it receives is of the same polarity as the terminal of the cell to which it is connected and the amount of electricity held depends upon the capacity of the conductor. At the same time it is always found that when a conductor is charged as above described, an equal charge of opposite polarity is induced on the bodies surrounding it. If two sheets of tin-foil, for instance, are insulated from each other by means of a sheet of mica and one of them is charged as above, the other will be found to have an equal charge of opposite polarity. This action by which bodies are charged through an insulating medium is called *electro-static induction*.

(p) *Condenser*.—A condenser is a device for storing static electricity. It consists of two insulated conducting bodies separated from each other by an insulating material. The common form of condenser used in telephone work consists of sheets of tin-foil separated by sheets of paraffin-paper. However, any two insulated bodies, as, for instance, two parallel wires or a single wire and the surface of the earth, or the

metallic conductor in a submarine cable and its protecting armour, act as condensers and have a certain *capacity* or ability to receive an electrical charge depending on their area, nearness together, and the character of the insulating medium between them. Condensers act as a complete bar to the passage of direct currents. Alternating currents, however, will produce through a condenser the same effects as would be produced were the condenser not in the circuit. This results from the inductive effect between the plates of the condenser, and while there is no actual passage of the current through the condenser the results produced where alternating currents are concerned are the same as though the condenser were not in the circuit. The effectiveness of this action, however, depends upon the frequency of the alternations and the capacity of the condenser. High frequency and large capacity produce better results than the opposite properties.

(q) *Wire Measure, the Mil.*—The mil is the unit of measurement for the cross-section area of wires. It equals one one-thousandth of an inch ( $\frac{1}{1000}$  or  $\cdot 001$  in.) The circular mil is used as the unit of area for circular wires and the square mil for rectangular conductors.

### Section 86—Parts of the Magneto Telephone.

A magneto telephone instrument such as is used on forest lines consists essentially of seven parts, as follows:—

1 Receiver	4 Induction coil	6 Ringer
2 Transmitter	5 Generator (magneto)	7 Switch-hook
3 Battery.		

To these are generally added a *condenser* wired in series in the receiver circuit, and the whole is inclosed in a *wooden case* and wired with insulated copper wires.

Various accessory equipment is also employed. The more important of these accessories are described in a following section of this chapter.

#### 1—RECEIVER

The first of the distinctive parts of the modern telephone to be invented was the receiver. This was the invention of Prof. Alexander Graham Bell. For a time it was the only one of the distinctive portions of the modern telephone employed, and served as both transmitter and receiver. It exists to-day essentially as first invented, though many minor modifications have been made in its construction, and it has ceased to be regularly employed as a transmitter.

The common bipolar receiver consists of a horseshoe-shaped permanent magnet, to each pole of which is attached a soft iron core, around which is placed a winding of fine insulated wire. Both coils are joined in series and the two ends of the wires are brought to binding-posts within or at the base of the shell to which the receiver cord is attached. A small, thin, circular iron plate or diaphragm is held at a distance of  $\cdot 015$  in. in front of cores of the magnet coils and the whole is inclosed in a hard-rubber case.

The receiver when used as a transmitter is essentially a miniature dynamo. The vibrations of the diaphragm, caused by the sound waves that impinge upon it, produce disturbances of the magnetic field surrounding the poles of the permanent magnets and thus generate minute currents in the coils which flow out over the line and cause similar disturbances in the magnetic field of the magnets at the other station. These, in turn, produce vibration of the diaphragm similar to those that produced the currents originally, and these vibrations cause sound waves which reproduce the sounds made in the first instance. The currents that may be produced in this way, however, are extremely minute and have not sufficient pressure to operate successfully over long lines of high resistance. The receiver, therefore, is not an efficient

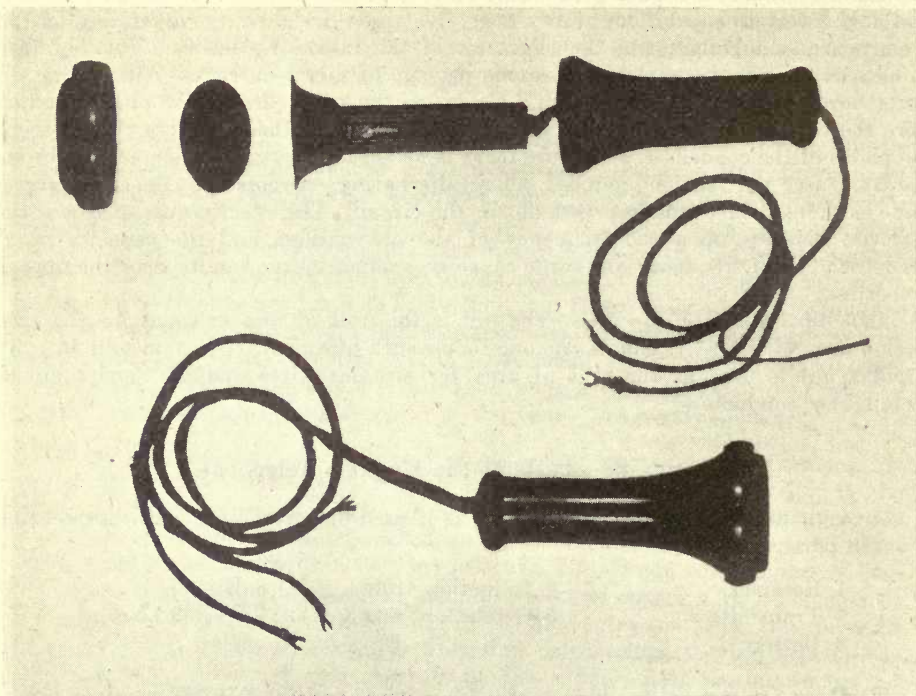

Fig. 70 Bipolar hand receiver

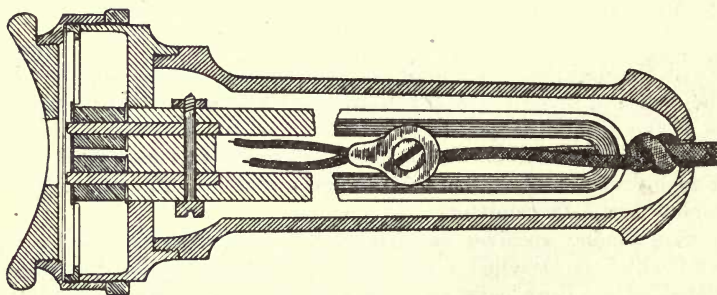

Fig. 71 Longitudinal section of bipolar receiver

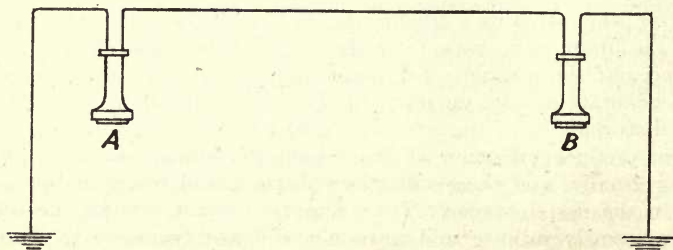

Fig. 72 Diagram of telephone circuit, first stage

transmitter. It is immensely sensitive to small currents, however, being in this respect one of the most amazing instruments that has ever been produced. As an instance, it may be stated that experiments have shown that the work performed by a weight of only one pound falling through a vertical distance of one foot would involve sufficient energy to maintain an audible sound in a receiver continuously for about 250,000 years.

In its most primitive form, therefore, a telephone consists simply of two receivers joined together by a wire of some conducting material, as in Fig. 72. This largely explains how, as most operators of telephone circuits have learned, speech may often be transmitted through the receiver of the ordinary instruments when the transmitter itself is out of order.

The modern receiver is an extremely simple instrument and almost immune from serious injury. Only gross carelessness can result in a broken shell or bent diaphragm, and this is generally the extent of any damage to a receiver. Only very rarely do the coils become burned out by lightning, or the permanent magnet become unduly weakened through loss of magnetism.

The receiver cord by which it is connected to the telephone may cause trouble. It must be extremely flexible, and is therefore made of insulated tinsel wires. These sometimes break, especially where they join the tips, thus introducing a fault into the circuit.

## 2—TRANSMITTER

The limitations of the magneto telephone as a transmitting instrument soon started investigators working on the production of a more efficient transmitting device. The need of a stronger current than can be generated by the magnetic field of the Bell instrument was apparent, and the solution was found in the modern carbon microphone or transmitter. This instrument is based on the principle early set forth by Du Moncel that, "if the pressure between two conducting bodies forming part of an electric circuit be increased the total resistance of the path between them will be diminished, and if the pressure be decreased there will be an increase in the resistance." Other investigators showed that a loose contact was an important feature in securing the necessary variations in resistance to cause variation in current, so that the problem became one of contriving some device by which a conducting material forming part of the telephone circuit might afford a loose contact, the pressure on which could be varied by the sound waves produced by the voice and thereby through the varying resistance resulting, vary the current through the conductor. This varying current passing out over the line to a distant receiver would cause corresponding variations in the magnetic field surrounding the cores of the receiver magnet coils, and these in turn acting on the receiver diaphragm would cause it to vibrate and thus produce sound waves similar to those originally produced by the voice.

It was further discovered that, of all conductors, carbon was the one in which slight variations of pressure produced the greatest effect on the current. Carbon was, therefore, adopted as the material out of which to make one or both of the electrodes which formed the loose contact in the circuit.

In the magnetic telephone no battery is required but, as previously explained, the currents produced are extremely minute. With the microphone in the circuit, a battery may be employed and a current of much greater strength obtained. This current, the microphone, through the loose contact of the carbon electrodes, varies according to the varying pressures produced by the sound waves, and as the strength of the current varies, so also varies the tension between the diaphragm and receiver magnet at the distant station whereby the diaphragm is caused to vibrate and reproduce sounds as previously explained. The transmitter most commonly employed in America and the one used on the Forestry Branch standard equipment is known as the White or "solid-back" transmitter and is shown in Figs. 73 and 74. In this

transmitter two carbon disks are employed between which is a quantity of carbon granules. To one of these disks a light metal diaphragm is attached. This diaphragm is caused to vibrate by the sound waves impinging upon it, thereby varying the pressure

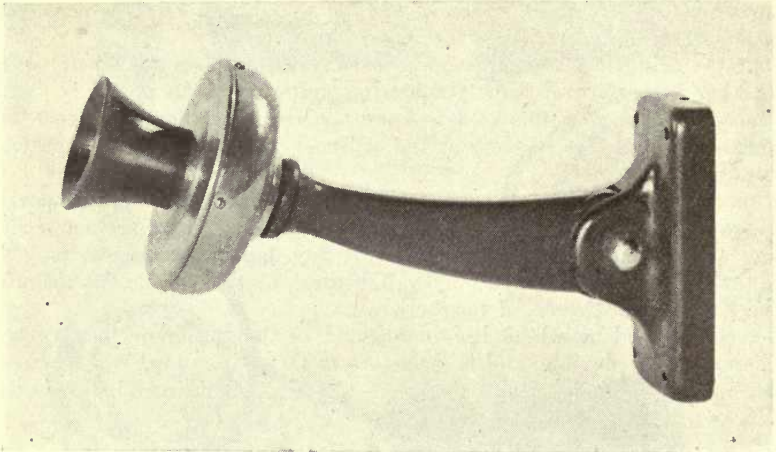

Fig. 73 Solid-back transmitter and transmitter arm

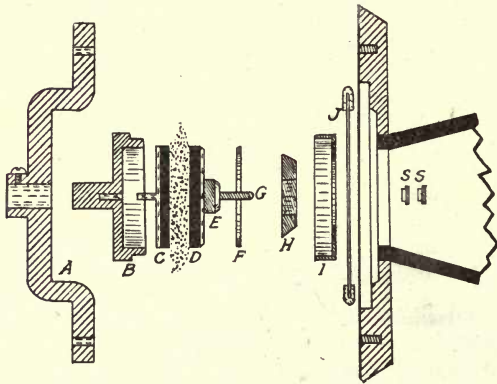

Fig. 74 Details of the solid-back transmitter

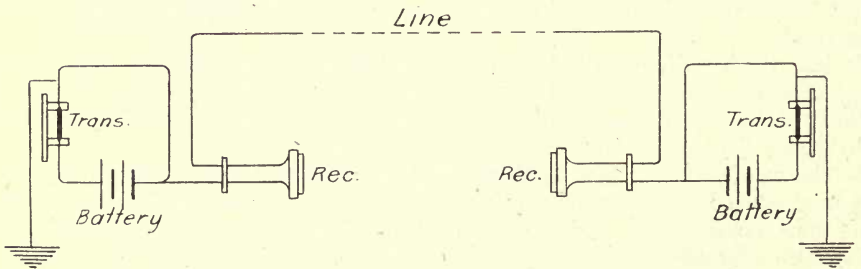

Fig. 75 Diagram of telephone circuit, second stage

on the carbon granules between the two carbon disks. The transmitter is so wired that these disks and the granules between them are in the battery circuit. The varying pressure, therefore, causes variations in the current which in passing through a receiver reproduces the sounds of the voice.



The next step, therefore, in the development of the telephone circuit consisted in the introduction into it of a voltaic battery and a carbon microphone or transmitter as shown in Fig. 75.

The back electrode B is a small metal case held to the support A by a lock screw. It carries in it the metal plate C, which bears a carbon face. Over this is a similar plate D and between the two is placed a quantity of carbon granules. The plate D carries the screw-threaded bars E and G. Over these fits the mica washer F, the nut H, and the screw-cap I. The bar G projects through the vibratory diaphragm J, which is held in place by the nuts S and S.

The transmitter is perhaps the most delicate portion of the modern telephone set. It is readily burned out by atmospheric electricity, and the carbon granules sometimes pack together, especially if they become damp, thus interfering with transmission. No one but an expert instrument man should ever undertake to repair an injured transmitter.

### 3—BATTERY

For telephone service what is known as an open-circuit cell is preferred as a source of electric current for talking purposes. As a rule a battery of two or three such cells is used. It might seem that transmission could be improved by the use of a very strong current, but the difficulty arises that such currents heat the carbon contact in the transmitter, and, in time, ruin it. For this reason low-resistance, low-voltage batteries are preferred.

Open-circuit cells are those which have the power of recuperating through depolarization whenever the circuit is left open. They are not suitable for prolonged continuous use, as are closed-circuit cells, which work best when in constant use. As will be later explained, the talking circuit of a telephone is always open except when the telephone is in use or the receiver off the hook and, therefore, open-circuit cells are the best for this service. The greater convenience of dry cells has led to their general adoption for telephone purposes. These are in all respects like ordinary cells except that the liquid solutions are mixed with some absorbent material and so rendered practically solid. There is thus little danger of liquids spilling or leaking out and causing damage. At the same time this danger is not entirely absent and batteries should never be carried in telephone sets, especially when lying on their sides. In this position, if there is any defect in the shell of the battery, some of the contents may leak out and corrode the wiring and other metal parts with which they come in contact. Dry cells, of course, become exhausted in time and must be renewed just as do other forms of primary cells.

### 4—INDUCTION COIL

The next important step in the development of the telephone after the invention of the transmitter was the introduction of an induction coil into the circuit by Edison. This, in fact, marked the beginning of practical telephone development, since, prior to the use of an induction coil, the range of transmission was extremely limited. Even after the transmitter was employed, it was found that the changes produced in the total line resistance by the varying pressure on the carbons were so small in comparison to the total line resistance as to produce variations in the current that were scarcely perceptible in a distant receiver. The problem, therefore, was to arrange some means by which the voltage of the current going out over the line could be increased, other than by increasing the voltage of the battery, which we have already seen had certain limitations.

It had further been noted that the telephone receiver was more sensitive to minute alternating currents than to the varying direct currents such as had up to this time been employed, but no means by which an alternating current might be employed had been devised.

The induction coil, as used in the telephone, accomplishes both of these objects. It is, of course, a fundamental fact of electrical induction that any change in a current in the primary winding of an induction coil, such as the opening or closing of the circuit, or the increasing or decreasing of its strength either by changing the voltage or the resistance, induces a momentary current in the secondary winding. These momentary induced currents are in the same direction as the current in the primary

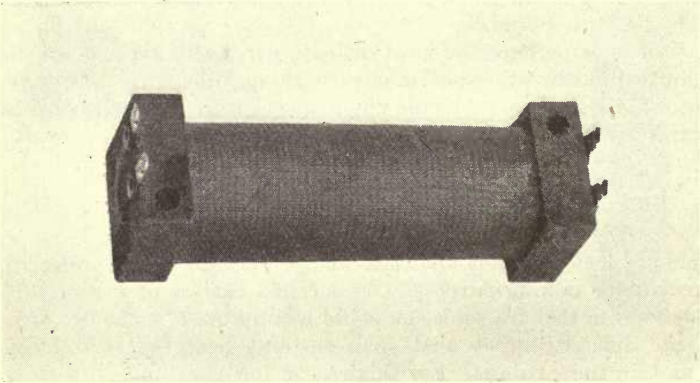

Fig. 76 Telephone induction coil

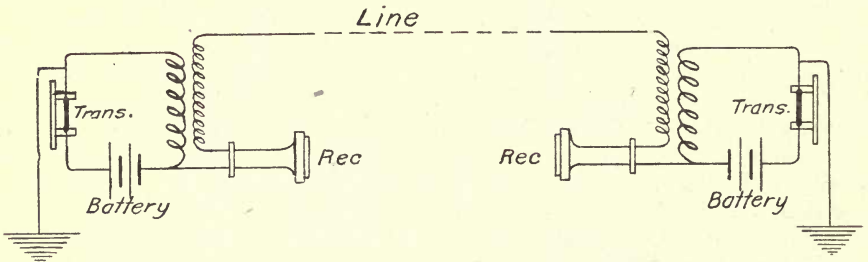

Fig. 77 Diagram of telephone circuit, third stage

when caused by a decreasing of the primary current, and in the opposite direction when caused by an increase in that current. Now the effect of the varying pressure on the carbon granules in the transmitter is to alternately increase and decrease their resistance, thereby alternately diminishing and increasing the strength of the current flowing through them; and if the primary of an induction coil is introduced into the circuit with a transmitter and a battery, the momentary currents induced in the secondary of this coil will alternate in a similar manner according to the law of induced currents. Thus, the desired alternating current is secured.

Moreover, the voltage of these induced currents is very greatly increased. This depends upon the construction of the induction coil itself, the rule being that the voltage of currents in the secondary bears the same relation to the voltage of the primary current as the number of turns in the secondary winding bears to the number in the primary. Thus, if the primary winding consists of 100 turns and the secondary of 2,500, the voltage of the secondary currents will be 25 times that of the primary. Since, as has already been explained, the receiver is sensitive to currents of quite minute amperage, a high voltage that will enable the current to overcome line resistance rather than a high amperage and low voltage is desirable.

The part played by the induction coil in the modern telephone is of immense importance since, as has been stated, its use marks the beginning of practical long-

distance transmission. In brief, it accomplishes three things, all important to successful telephone operation:—

(1) It produces true alternating currents in place of the direct current of varying intensity produced by the transmitter and battery alone.

(2) It produces currents of much higher voltage (E.M.F.) than it is practicable to secure from voltaic cells operating through carbon transmitters alone.

(3) By limiting the circuit over which the current from the battery flows, to the very short one including only the battery itself, the transmitter, and the primary of the induction coil, and by making the last of low resistance, the variations in resistance produced by the varying pressure in the transmitter under the influence of sound vibration are in comparison to the entire resistance quite large. These impulses are impressed upon the secondary current with an increase in strength and amplitude corresponding to the increased pressure of that current, and are successfully transmitted out on the line to the receiving stations over very great distances.

The telephone circuit as produced by including in it an induction coil is shown in Fig. 77. This shows diagrammatically the circuit of the speech-transmitting portion of the telephone substantially as it exists to-day. The rest of the telephone set is required for signalling and is only incidental to the portion employed in transmitting the sounds of the voice.

#### 5—MAGNETO GENERATOR

The generator is simply a small dynamo. It differs from the large dynamos used in generating power and light currents only in having permanent steel magnets

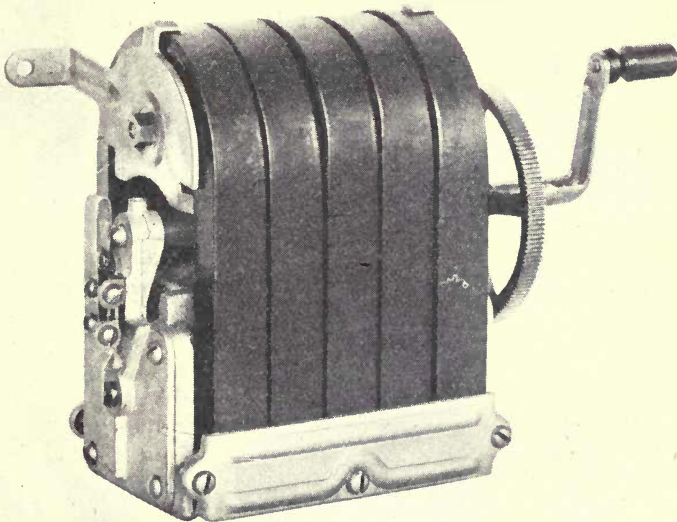

Fig. 78 Magneto generator, five bar

in place of the usual electro-magnets. Generators in modern telephones are of various sizes, depending on the kind of service for which they are intended. The largest and most powerful are built with five magnets (five-bar generators) and are the type used in the Forestry Branch standard instruments. They are intended to ring through very high resistances, such as are encountered on forest telephone lines,

and for the size of the machine are extremely powerful and efficient generators of electric currents. They produce true alternating currents at about 65 to 75 volts and a frequency of 15 cycles per second, are very compactly built, and are not very likely to give trouble.

The two principal parts of the generator are the magnets and the armature. The former are horseshoe-shaped and are made of a high quality of steel, and strongly magnetized. Between the poles of the magnets is placed the armature. It consists of an H-shaped laminated iron core around which is wound a coil of fine insulated wire. A small crank with gear wheels is used to rotate the armature at a high rate of speed between the poles of the magnets, thus producing the current. It will be apparent, however, that since the generator serves only to produce current for ringing purposes there is no reason why it should be permanently in the circuit. On the other hand, there are certain objections to such permanent connection. The armature winding if permanently bridged across the line would form an additional path to ground, thus reducing the current available for ringing other instruments. Also, injury from outside currents might occur which can be avoided if the armature is disconnected while it is at rest. For these reasons the magneto generators are usually arranged with an automatic circuit-breaking device, by which the winding of the armature is thrown out of the circuit whenever it is at rest and is thrown into the circuit by the act of turning the generator crank. It will be noted that as soon as the crank on the standard instrument is turned it slips inward a fraction of an inch. This slight movement serves to close the circuit and throw the coil of the generator armature on to the line, thus permitting the current from the generator to flow out over the line to ring the bells at the distant stations.

#### 6—RINGER

The low-frequency alternating current from the magneto generator operates a polarized bell or ringer (Fig. 79) at each station by means of which the attention of the

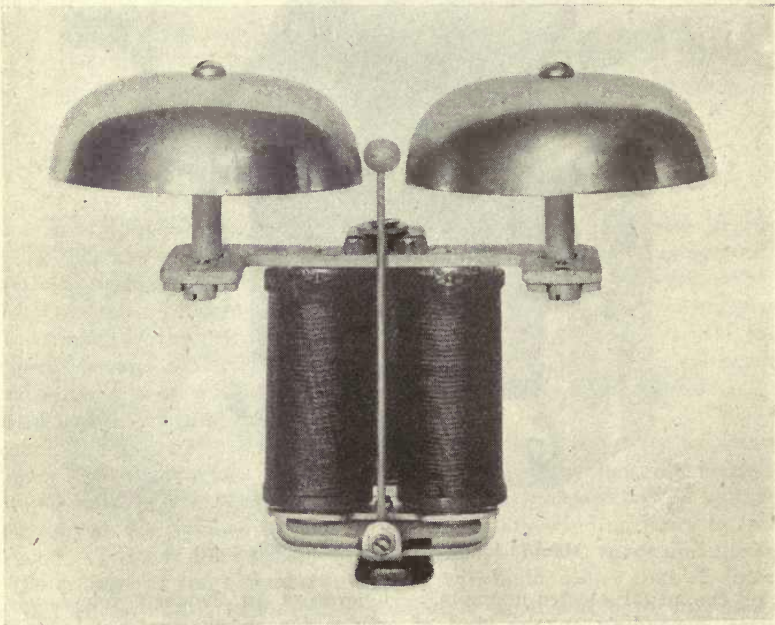

Fig. 79 Polarized ringer, unbiased type

distant station is secured. Code ringing is employed on forest lines exclusively; that is, each station has its own signal or call letter made by a combination of long and

short rings, and, although the bells at all stations on the line ring whenever the generator is turned at any one of them, yet, by employing a code, only that station responds whose code signal is sounded. The polarized bell consists of two coils of fine wire, (see L, L1 Fig. 96) with soft iron cores held between the poles of a U-shaped permanent magnet, NS by being attached to S. This has the effect of prolonging the S pole so that the opposite ends of the coil cores have S polarity. Across one end of this pair of coils is a soft iron armature F pivoted at its centre by the screw E. To its centre is attached a slender rod H ending in a small metal ball between the two bells K, K1. Armature F under the influence of the adjacent magnet acquires S polarity at the centre and N polarity at each end. The armature in this condition is attracted equally to both cores and rests against one or the other as it may happen to stop. The coils, however, are connected in series and wound in opposite directions. If, then, a current passes through them it will tend to increase the strength of one pole, and to decrease the strength of or change the polarity of the other. Thus, if L is strengthened, L1 will be weakened and the armature F will be attracted to L, causing the clapper H to strike the bell K1. However, the current being an alternating one, the changes in the strength of the poles will take place first on one side and then on the other alternately as the current moves, first in one direction and then in the other. As already stated this takes place fifteen or more times per second, according to the frequency of the alternations of the current from the generator. The clapper H therefore is caused to vibrate very rapidly, striking the bells at each vibration and causing an almost continuous ringing sound.

For bridging service as used on forest lines, ringer coils are wound to a resistance of 1,000, 1,600 or 2,500 ohms. The standard Forestry Branch instruments and extension bells have 2,500-ohm ringers. Such high-resistance ringers are employed on heavily loaded lines for the purpose of preventing the escape of current through the ringer circuit of the numerous instruments attached to the lines. These high-resistance coils, which are generally bridged permanently across the line, are wound so as to give a very high magnetic retardation, and, although readily operated by the low-frequency currents from magneto generators they are effectual blockades against the high-frequency current of the talking circuit. The higher resistance also is a considerable aid in signalling, since it operates to reduce the amount of current that is diverted to the ground at each instrument and therefore increases the number of instruments that may be rung on a given line. It must be noted in this connection, however, that all ringers on the same line must be wound to the same resistance, as otherwise the low-resistance ringers will tend to prevent the others from receiving the proper amount of current.

In some instruments the ringer is thrown out of the circuit while the telephone is being used for talking. This is not the case, however, in the standard Forestry Branch instruments. But, although the ringers in these instruments remain permanently bridged across the line at all times, their high resistance effectually bars out the talking current, so that this current passes through the receiver to the ground in the instruments in use and not through the other path offered through the ringer coils.

It will also be noted in the diagram of the wiring of the standard telephone (Fig. 97) that when the generator of any station is being used to ring another station, two paths are available to the current, one through the line wire to the distant station, thence to the ground, and back to the generator whence it came; the other through the ringer of the calling station itself. By this means a portion of the ringing current is shunted through its own bell and this bell is rung the same as are all other bells on the line. The advantage of this arises from the fact that the ringer is particularly liable to trouble due to several causes. It may, for instance, fail to ring owing to improperly adjusted bells or armature, or to coils being burned out by lightning, or to faulty connections in the ringer wiring, or to a short circuit on the line or in the protector. Such trouble is immediately noted as soon as an attempt is made to ring a distant station when the bells are permanently connected across the line.

## 7—SWITCH-HOOK

It has been previously indicated that there are two entirely different sources of electric current in a magneto telephone set. The one is the local battery; the other is the magneto generator. The current from the local battery traverses a very short circuit

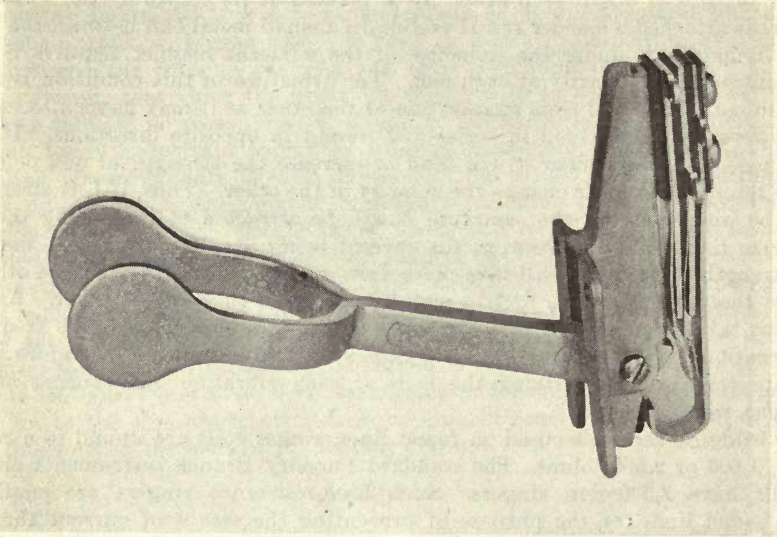

Fig. 80 Telephone switch-hook

through transmitter and primary of the induction coil only, but induces a secondary current in the induction coil which traverses the whole line, thus enabling conversation to be carried on. The current from the magneto generator flows out over the line, also, and actuates the bells at all other stations for signalling purposes. When the instrument is not being used it is obviously undesirable to have the parts used for talking connected to the line. If this continuous connection existed, conversation between any two stations would be heard at all other stations and as part of the talking current would pass through each receiver connected to the line the amount received by any one of them would be proportionately reduced. The leakage through the low resistance of the numerous receivers and induction coils, moreover, would make signalling impossible over long lines with numerous instruments. Furthermore, the continuous current that would flow through the transmitter circuit would quickly exhaust a battery of the open-circuit type such as is used in the telephone. Accordingly, in all telephones a device is installed by which the talking circuit is cut off from the line when not in use and the transmitter circuit is opened. This is accomplished by the switch-hook which is so arranged that when the receiver, which ordinarily is suspended from it, is removed, the talking circuit is automatically thrown into the line. Conversely, when the receiver is placed back on the hook, the depressing of this hook opens the circuit. A large number of devices for accomplishing this have been invented. The one shown in Fig. 80 is the type employed in the Forestry Branch standard instruments in wall sets and desk sets. In hand sets such as the 1375-A or the 1004-A portable instruments, push-button devices are used to accomplish the same result. It is well, perhaps, to note that in case one of these push-buttons is depressed for any long period, the small battery of the portable instrument is very likely to become exhausted. This sometimes happens with the 1375-A hand set where the push-button projects prominently from the side of the hand set and when packed for

transportation with the receiver cord wound around it, it sometimes is depressed for a long time. Most of the trouble with exhausted batteries in this set is probably due to failure to guard against this accident.

#### 8—ACCESSORY EQUIPMENT

In addition to the essential parts of the telephone previously described there are several pieces of apparatus generally used on forest lines about which it is desirable that some information be available to those in charge of such lines.

These include the following:—

- |                                     |                     |
|-------------------------------------|---------------------|
| (a) Condenser                       | (d) Switches        |
| (b) Howler                          | (e) Repeating coils |
| (c) Lightning-arrester or protector |                     |

(a) *Condensers*.—If two conductors, preferably in the form of thin plates such as layers of tin-foil, are placed close together with a non-conducting material or dielectric between them so that they are nowhere in direct contact and are then connected, one to each pole of a voltaic cell, it will be found that a certain amount of current will

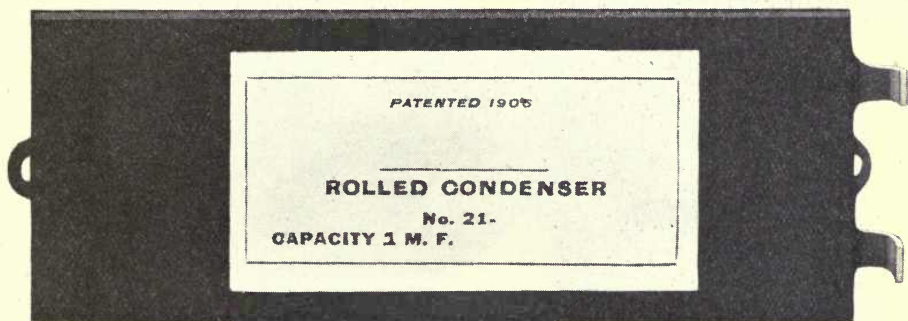

Fig. 81 Rolled condenser

flow from the cell to the plates until they become fully charged with static electricity. Such a device is called a condenser. The ability of an arrangement of this sort to receive an electric charge, generally termed its *capacity*, varies in direct proportion to the area of the plates, inversely as the square of the distance between the plates, and directly as the specific inductive capacity of the dielectric. It is not essential that the conductors be in the form of plates, however. Any two surfaces, such, for instance, as the surfaces of two telephone wires placed parallel to each other and insulated from each other as on a metallic pole line, will act in the same manner. So also will a single wire line, the earth's surface forming one plate, the wire the other, and the air between them acting as the dielectric. A great many of the difficulties encountered in securing good telephonic transmission are caused by this electrostatic capacity of the line. This, however, is aside from the subject of condensers as exemplified in the accessory equipment of the telephone.

It was previously stated that if the talking circuits of the various instruments on a line were left in the circuit continuously instead of being cut out by the switch-hook when the receiver is hung up, it would be impossible to ring up the stations on the line, owing to the leakage of the calling current through the receiver circuit. The same thing takes place when on party lines a number of receivers are taken off the hooks by persons "listening in." Signals could not be transmitted over such lines

when several persons are "listening in," were it not for the use of a condenser in the receiver circuit. All standard Forestry Branch instruments are thus equipped, the wiring being as shown in Figs. 41 and 97.

The condensers used for this purpose consist of alternate strips of tin-foil separated from each other by waxed paper. They have a capacity of half a microfarad. A condenser acts as a complete bar to the passage of direct currents, or, in other words, it constitutes an open circuit. To alternating currents, however, it offers a more or less perfect path depending on the character of the current, particularly its frequency and the capacity of the condenser. The condensers used in the standard instruments readily permit the passage of the high-frequency currents of the talking circuit but bar out the low-frequency currents of the calling circuit almost completely. It is thus made possible to ring through, even though a considerable number of receivers may be off the hooks.

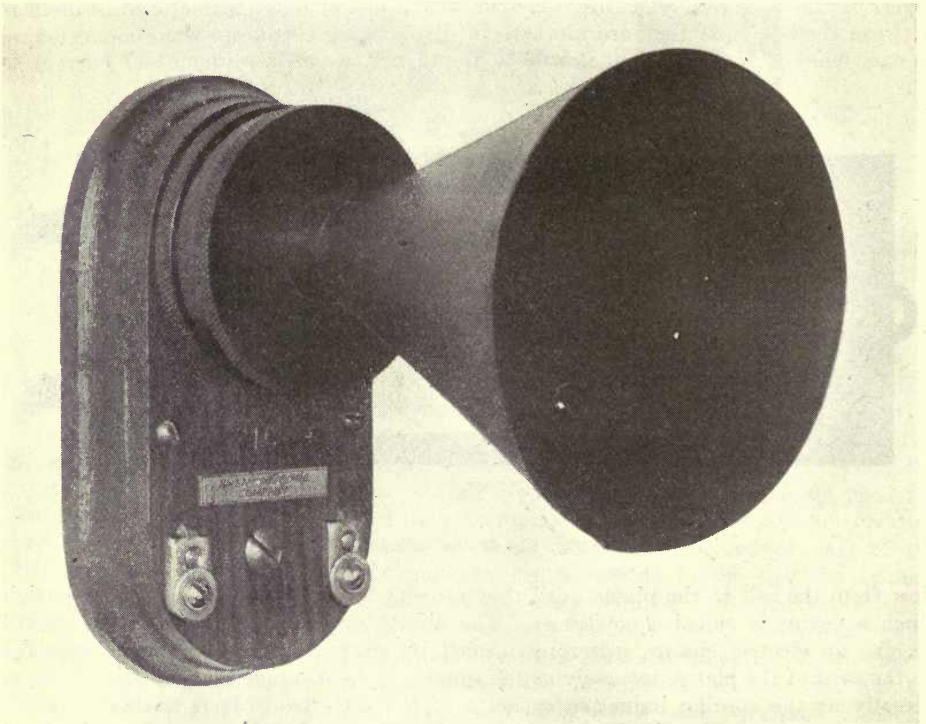

Fig. 82 Howler

Similarly, a condenser is used with the howler where vibratory currents are employed in signalling as with the 1004-A hand set. These vibratory currents are alternating currents of very high frequency which readily pass through the 1-microfarad condenser, wired in series with the howler. This condenser, however, effectively prevents the escape to the ground of the low-frequency alternating currents of the magneto generators, so that both types of signalling devices may be used on the one line without short circuiting or interference.

(b) *Howler*.—For the purpose of reducing the weight of the portable instruments as much as possible it was necessary to do away with the heavy magneto generator.



This was accomplished in the 1004-A hand set by using for signalling an induced current of high potential and high frequency acting upon a special type of telephone receiver at the distant station. The wonderful sensitiveness of the receiver to small currents of this kind has previously been explained. By this system, therefore, it is possible to work over very faulty lines where the ordinary generator currents are entirely lost through leakage or high resistance. The howler is the special form of receiver used to receive vibratory signals. It is the same as the ordinary receiver already described except that the pole pieces of the long, horseshoe magnet are attached to it at right angles. This is mounted in a wooden block for convenient attachment to the wall and is provided with a small megaphone which serves to concentrate the sound waves given off by the vibrating diaphragm. Howlers are connected between the telephone and the protector so that they are protected from injury by lightning or other high-tension currents and are not likely to get out of order. They must be carefully adjusted so as to produce the maximum sound, the adjustment being accomplished by tightening or loosening the screw-cap which holds the diaphragm in place. The type of howler used by the Forestry Branch is shown in Fig. 82.

(c) *Lightning-arrester.*—It is always necessary to protect telephone instruments against lightning. This is particularly true on many long-distance forest lines which cross through regions of high altitude where lightning is sometimes very prevalent. It is also necessary to provide special protection wherever telephone lines are liable

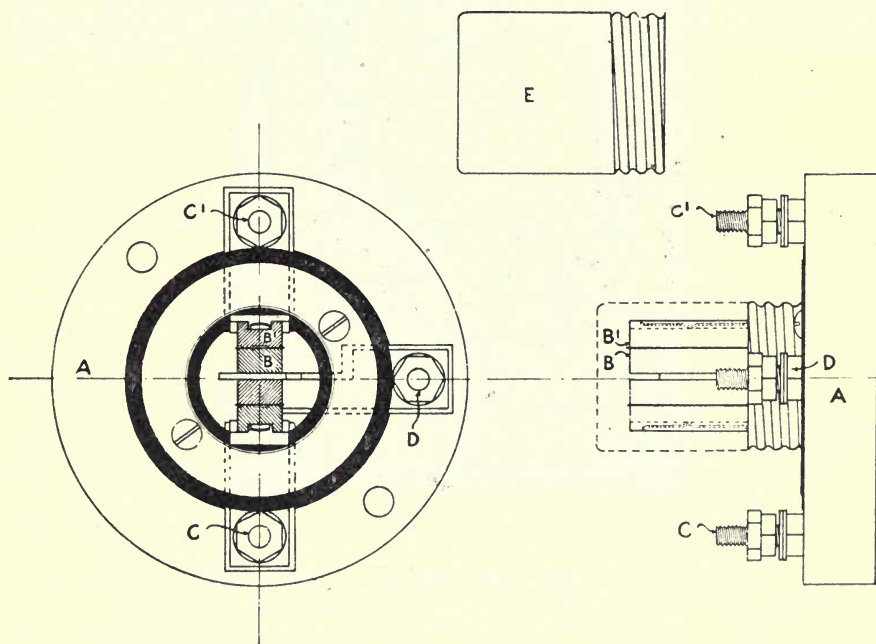

Fig. 83 Lightning protector for use where there are no power or light wires

to come in contact with wires bearing electric-light or power currents. Two types of protective devices are employed. In the lightning-arrester used by the Forestry Branch advantage is taken of the fact that a high-tension current such as lightning will jump a small air gap in seeking the shortest path to the ground rather than pass

through the long coils of the telephone ringer or other parts of the set. This arrester (Fig. 83) consists of a suitable insulating block A on which are placed two pairs of copper blocks B, B<sup>1</sup> held together by springs but not in direct contact with each other because of a thin sheet of mica placed between them. A brass bar extends from binding-posts C and C<sup>1</sup> to the copper blocks nearest them. A similar bar extends from the inner blocks to binding-post D. The line wire is connected to post C and the ground wire to post D. To all ordinary telephone currents the air gap between the copper blocks is an effectual bar. Dust collecting between the blocks causes a short circuit but is largely prevented from accumulating by the brass covering cap E. By

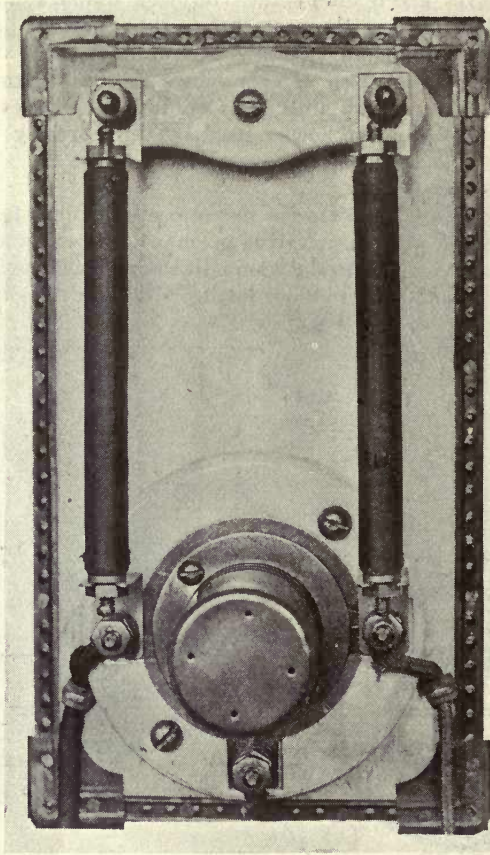

Fig. 84 Protector with fuses, for use where there are power and light wires. Note method of binding edge of asbestos mat with metal tape

a lightning current, however, the path to the ground across the air gap is taken in preference to that through the instrument, and in this way such currents are successfully prevented from damaging the telephones.

The effect of lightning-arresters on high-tension currents other than lightning is somewhat similar, but these currents are very likely to be continuous instead of merely momentary as are lightning currents. A "cross" with such a current would therefore result in a constant sparking across the air gap of the protector, which would almost certainly cause a fire if it did no other serious damage. To prevent

this a line fuse must be introduced in the line between the protector and the outside wires. This fuse contains a short length of easily fusible metal which melts whenever a current of greater strength than the fuse is designed to carry comes over the wire. The circuit is thus opened and damage by sparking is prevented, as the air gap through the fuse is entirely too large for any ordinary high-tension current to jump. Fig. 84 shows a protector designed to guard against both lightning, and power and light currents which has been adopted by the Forestry Branch for use wherever both kinds of dangerous currents are encountered.

This means that on many reserves all instruments must have the combined lightning and high-power protector, because no matter on what part of the circuit a power line is encountered it is necessary that all instruments on that circuit be fully protected.

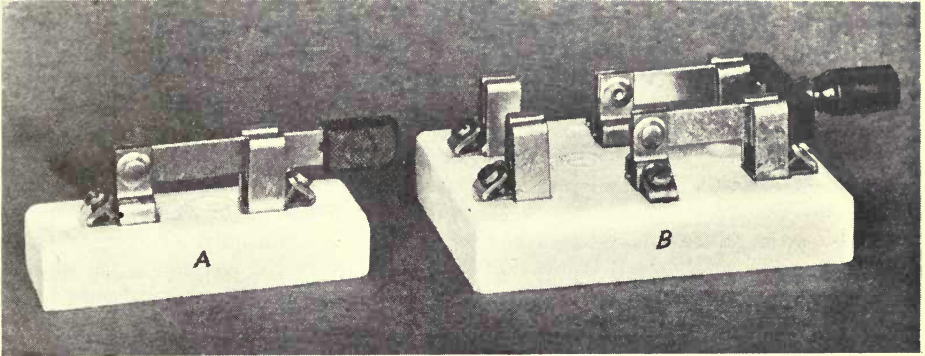

Fig. 85 Baby knife-switches. (A) Single pole, single throw (S.P.S.T.). (B) Double pole, double throw (D.P.D.T.)

(d) *Switches.*—For convenience in separating a branch line from a main line, for cutting off stations not in use, for dividing extra long lines into shorter sections, and for other similar purposes, it is frequently necessary to install switches in telephone circuits. As the currents carried are all comparatively weak, no very elaborate switching devices are needed, and a simple, inexpensive form of knife-switch is found to serve all purposes adequately. Those mounted on a porcelain base as shown in Fig. 85 will be found most satisfactory. They are fastened in place with round-head, blued screws of suitable gauge and length.

Switches of this kind are classified by the number of poles either as single, double, triple, etc. They are also further divided into two classes, depending on whether they make one contact or two. Those making but one contact are called “single-throw” (S.T.); those making two, “double-throw” (D.T.). For most purposes a single-pole, single-throw switch (S.P.S.T.) is sufficient (see Fig. 85). Where more complex connections are involved various multiple-pole switches of either the S.T. or D.T. type may be required. It is always to be remembered in placing switches that the more connections that can be made or broken by the movement of one switch, the less likelihood there is of confusion in operating the switchboard. Switchboards should always be designed, therefore, to simplify as much as possible the movements required by using multiple-pole switches wherever feasible.

(e) *Repeating coils.*—These are simply a special form of induction coil generally employed for the purpose of preventing the unbalancing of metallic lines when joining grounded lines to them. While it is possible to neutralize inductive disturbance on metallic lines by proper transposition, this effect is lost if a grounded line is joined directly to a metallic line without interposing a repeating coil. By inserting a repeating

coil in the circuit, direct metallic connection between the two lines is avoided, as each is joined to a separate winding of the coil. Transmission, therefore, through the coil is accomplished by induction and if desired it may be accompanied by a stepping-up or a stepping-down of the voltage in passing from one line to another. A great many repeating coils, however, do not alter the voltage, but have both windings of the coil alike.

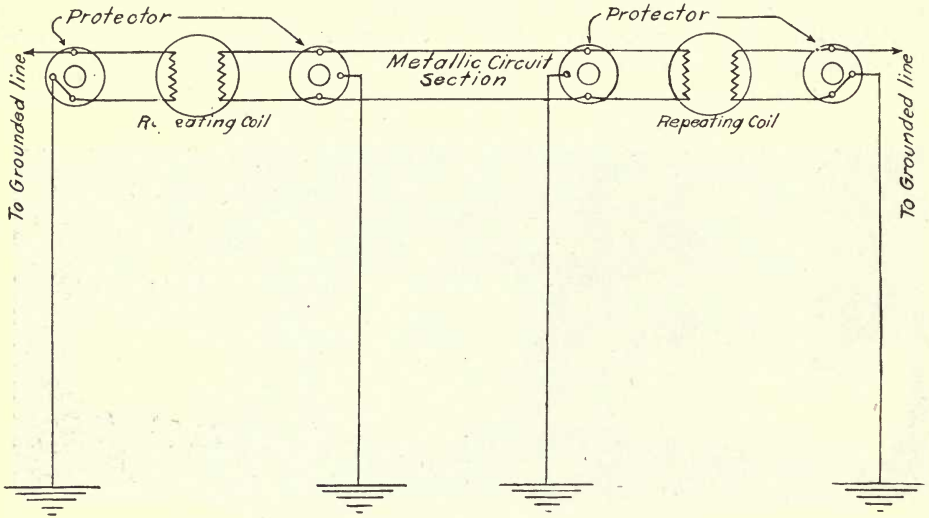

Fig. 86 Method of inserting a metallic circuit section in a grounded line to overcome induction disturbances

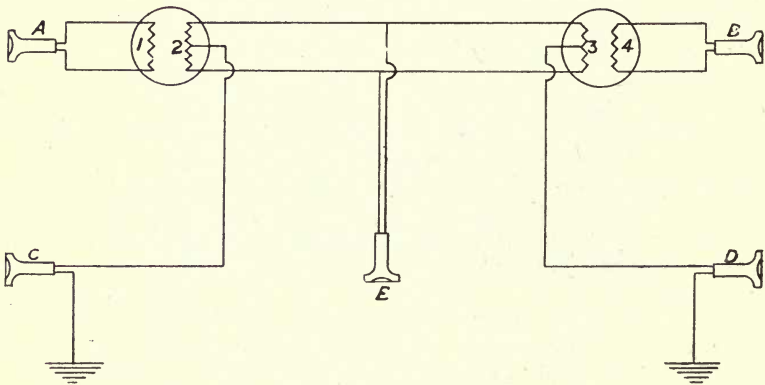

Fig. 87 Diagram of a phantom circuit

To connect a grounded and a metallic circuit through a repeating coil, both wires of the metallic line are joined to the ends of the same winding of the coil. The single wire of the grounded line is then joined to one end of the other windings, the second end being grounded. By using two such coils, a grounded line may be transformed into a metallic line through a noisy portion of the length, and all foreign noises perfectly eliminated. This method of connection is shown diagrammatically in Fig. 86.

The standard Forestry Branch repeating coil is a special type adapted so that it may be used for several purposes. In this coil there are four independent windings, each with a pair of outside terminals. By joining two pairs of these windings together by jumpers between the proper terminals, as shown in Fig. 56, a repeating coil of two independent windings is secured, which may be used for the purpose above described. This arrangement of coils, however, also makes possible the making of a connection to the exact centre of either one of the two windings, since each is composed of two separate but similar windings joined by an external jumper. Such a connection to the centre of one of the windings of the repeating coil is shown in Fig. 56 by the heavy line leading from the terminal marked 3 and labelled "To Phantom." The coil, therefore, may also be used to secure two distinct telephone circuits from a single metallic line as shown in Fig. 87. In this figure the circuit A B is metallic with a repeating coil at each end. Transmission between the through stations A and B over the metallic line takes place inductively through the two coils. Each coil consists of two windings. Winding 1 is similar to 4; winding 2, to 3. The second circuit C D is taken off from the centre of winding 2 and winding 3, thus assuring that the resistance in the coil on both sides of the point of connection is the same at each end. To work perfectly the ohmic resistance of the two line wires must also be equal. It will then be apparent that current entering at 2 from station C will divide evenly at 2 and pass over both wires to the coil at station B, where it will again unite and pass through D to the ground. At any intermediate station such as E, for instance, no effect will be noticeable, because since both wires carry an equal current with no difference of potential there is no tendency for current to pass from one to the other and therefore it cannot flow through the apparatus at station E. The circuit taken out of the centre of the coils at 2 and 3 is called a "phantom" circuit and by its use two distinct independent circuits, one grounded, the other metallic, may be secured from a single pair of wires. Similarly three distinct metallic circuits may be secured from two pairs of wires, and various other combinations whereby several independent telephone circuits may be superimposed on the same wires are possible.

### Section 87—Methods of Connecting Telephones to Line

Forest protection telephone systems are always party lines; that is, there are a greater or less number of instruments all connected to the same line at different stations between its terminals. There are two general systems employed for connecting up the instruments on a party line of this kind: the series system and the bridging-bell system. Of these, only the bridging-bell system is of any use on forest lines and, in fact, the series system is now little used for any purpose.

#### 1—SERIES SYSTEM

This is the oldest method of connecting the several instruments on a party line, but is now so little used and is so inapplicable to forest-protection telephone lines that only the briefest consideration is desirable. The method of connection is fully illustrated in Figs. 88 and 89, the first of which shows a series connection on a metallic circuit and the second a series connection on a grounded circuit. It will be easily seen from these diagrams that the talking current between any two telephones on the line has to traverse all the bell coils of the intermediate telephones. These, therefore, must be wound to very low resistance, generally about 80 ohms, and even then the current is so weakened by the combined effects of resistance, impedance, induction, and leakage that speech transmission is impracticable except over a short line with relatively few telephones connected to it.

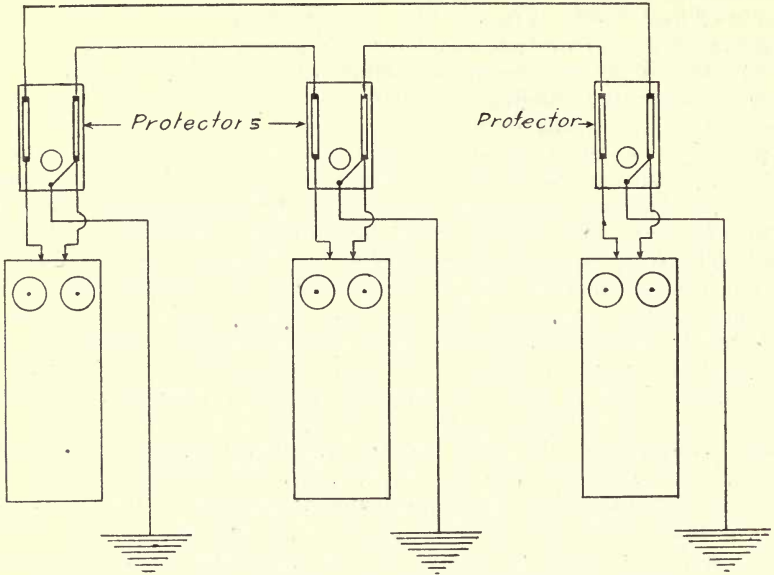

Fig. 88 Telephones connected in series on a metallic line

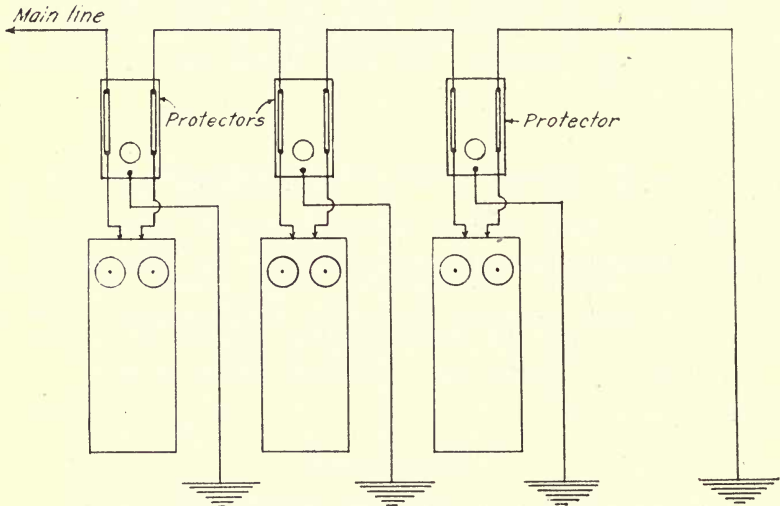

Fig. 89 Telephones connected in series on a grounded line

## 2—BRIDGING-BELL SYSTEM

For the purpose of overcoming the difficulties inherent in the series system the bridging or multiple method of connection was adopted and is now the standard method of connecting up party lines such as are employed in forest protection. All the standard instruments of the Forestry Branch are wired for this system only, and all lines installed are of the bridged type either grounded or metallic. The method of connecting the telephones to the line by this system is shown in Figs. 90 and 91, the

first being a bridged, grounded circuit and the second a bridged, metallic circuit. In this system, as will be seen from the figures, each instrument is on a separate leg from the line to the ground or on a "bridge" between the two wires of a metallic circuit.

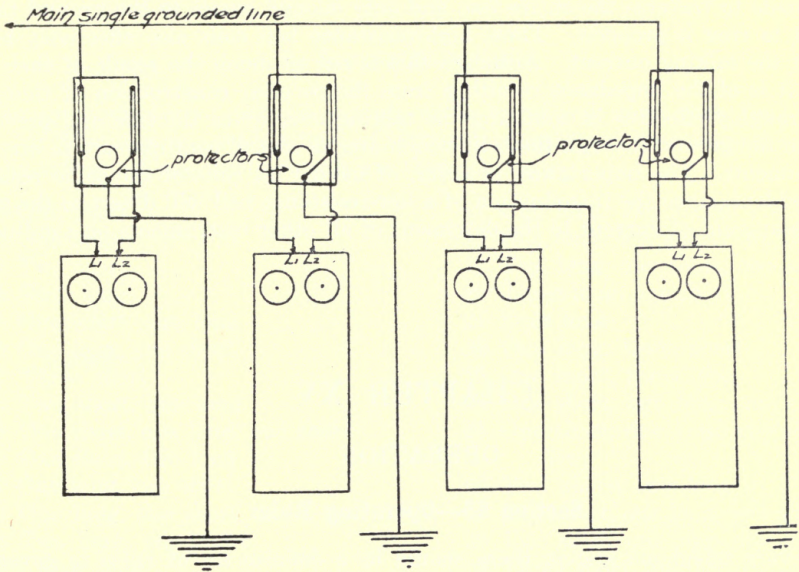

Fig. 90 Connecting bridging telephone on a grounded line

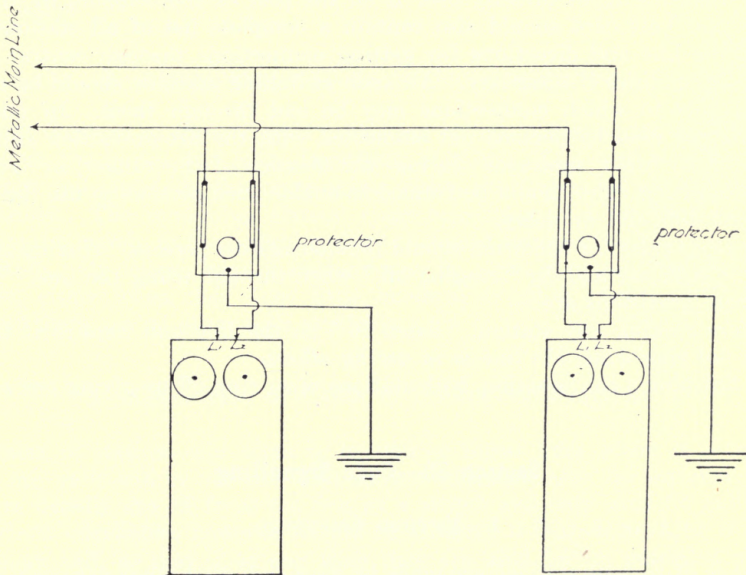

Fig. 91 Connecting bridging telephone on a metallic line

The bells of bridged telephones are constantly in circuit and each instrument, therefore, at all times forms a separate path for both talking and ringing currents to the ground or the return wire. It will, therefore, be evident that with low-resistance bell coils the line resistance between instruments, except on very short lines, might

easily be several times as great as the resistance of the coils, and the bulk of the current would, therefore, be shunted to the ground through the bells of the nearest instruments and would not reach the more distant instruments in sufficient amount to ring them. Bridging bells, therefore, are wound with coils of very high resistance—2,500 ohms in the Forestry Branch instruments—only by this means the ringing current is made to traverse the entire line and only enough passes to the ground through each bell to ring it properly. These high-resistance bell coils also effectively bar out escape of the talking current. Although this is not so much the result of their resistance as it is of the impedance resulting from the peculiar construction of these coils, it is thoroughly effective in confining the talking current to the line and preventing leakage to the ground through the bells which are, as stated, continuously in circuit on all instruments. The importance, however, of having all coils of the same resistance will be evident, since the introduction of a low-resistance bell will divert to the ground an excess amount of current to the detriment of all other instruments on the line.

## CHAPTER XV

### OPERATION

#### Section 88—Operating Rules

On every telephone system there should be a definite set of rules to govern the operation of the lines and stations. These are usually very simple and should be made up in the form of a printed or typewritten card and fastened to the wall close beside the instrument, or directly over it on the post or tree support in case of outdoor stations. This card should also contain a complete list of all stations and call signals on the line and directions for getting connections through central switching stations to other lines if necessary. All such switching stations should be mentioned with the points to which connections may be had through them. In many cases, instruments are used by persons not connected with the fire-protection staff to send news of fires or other messages during the absence of the ranger, or from a field station. Operating rules should be framed to enable such persons to use the telephone line without difficulty or delay.

In all cases rules for operation should provide against persons "ringing in" on the line when it is in use and for "ringing off" when through using the line. Two rules to cover these provisions are:—

- 1 Before ringing any station, "listen in" on the line and inquire if the line is busy. *Do not ring while the line is in use by others.*
- 2 On finishing a conversation, both stations must ring off by giving *one short ring.*

#### Section 89—Code Signalling

##### 1—METHOD EMPLOYED

The calls of various stations are made by long and short rings variously arranged. As a rule not more than four such rings need to be included in any one call or signal. Those stations which are called most often should have the most simple signals and those called least often, the most intricate. It must be noted, however, that "longs" transmit somewhat better than "shorts" over lines that are in poor condition, so that distant stations should, as a rule, have signals largely made up of long rings while the



nearby stations should have signals composed of "shorts." The assumption, of course, is that most of the calls originate at one end of the line as, for instance, at a supervisor's headquarters.

For the "ring off" signal, one short ring will be found most satisfactory.

For the main headquarters, one long ring is generally preferred.

## 2—LIST OF BELL CALLS

The total number of possible signals made up of not more than four rings is thirty. If five rings are used, a total of sixty-two signals may be employed but thirty generally suffice. These thirty signals are shown below:—

1 One short	17 One long, two short, one long
2 One long	18 One long, one short, two long
3 Two short	19 Two long, one short, one long
4 Two long	20 Three long, one short
5 One short, one long	21 Four long
6 One long, one short	22 One long, three short
7 Three short	23 One short, three long
8 Two short, one long	24 One short, two long, one short
9 One short, one long, one short	25 One short, one long, one short, one long
10 One short, two long	26 Two short, two long
11 One long, two short	27 One short, one long, two short
12 One long, one short, one long	28 Two short, one long, one short
13 Two long, one short	29 Three short, one long
14 Three long	30 Four short
15 Two long, two short	
16 One long, one short, one long, one short	

## 3—ASSIGNMENT OF CALLS TO OCCUPIED STATIONS

The first fourteen of these signals consisting of only three elements or less should be assigned to the busier and more important stations. The ones consisting largely of short rings and especially those beginning with a short ring, should be given to the nearby stations. The remaining sixteen rings consisting of four elements each are arranged approximately in the order in which they will transmit best over long lines in poor condition. Of course, nearby stations may be given a signal from near the end of this list, either when they have little business or when they have considerable business but there are no short calls available.

## 4—ASSIGNMENT OF CALLS TO UNOCCUPIED STATIONS

A number of stations will often be located on forest lines where it is not anticipated that any calls will be put in. The lookout telephone sets, for instance, mounted on posts are usually cut off from the line by a switch and only used for calling other stations. Such telephones, however, should be assigned a four-element, or if necessary a five-element, call, so that if at any time they are used for an extended period the various posted lists of calls will show the station signal. It is also advisable to reserve two or three of the better-transmitting three-element or four-element calls for the use of emergency stations.

## CHAPTER XVI

### MAINTENANCE

#### Section 90—General Principles

Inspection of telephone lines must be made regularly during the fire season, and special inspection made by the ranger or other officer in charge immediately after a severe wind, snow, sleet, or electrical storm, and after fires. Rangers and guards when on patrol duty must watch the telephone lines, cut any trees that may have fallen across them, and make any other necessary repairs. Tests must be made at a specified hour each morning during the fire season to see that no trouble exists. Each forest supervisor should establish a regular organization on his reserve for the proper inspection and maintenance of each Forestry Branch line. When instructed to do so by the district inspector daily service reports on Forestry Form 318 will be prepared and submitted for the lines covered by the instructions.

#### Section 91—Line

##### 1—GENERAL REPAIRS

The entire line must be gone over thoroughly at least once a year, preferably before the beginning of the fire season. Each pole should be inspected; brackets, insulators, and tie wires which are broken should be properly replaced; and all foliage and interfering timber cleared away. Poles should be examined for butt-rot and for twist. In the latter case it should be determined whether the pole has twisted to an extent to permit the line or tie to touch it. Loose guys or braces should be tightened and all loose or badly corroded joints renewed.

Line troubles will generally be traced to one or more of the causes given below. (Telephone Circular, April, 1916, United States Forest Service, District No. 5.)

- (1) Broken line wire.
- (2) Line wire resting on the ground.
- (3) Leaks through slight grounds by the line wire making contacts with foliage, trees, poles, or other similar objects.
- (4) Cross-talk and cross-ringing by contacts with other lines.
- (5) Short circuits and cross-contacts with other lines at switching stations.
- (6) Poor grounds.
- (7) Bad splices, and loose or corroded contacts at fuse and protector.
- (8) Circuits too long for the size of wire employed.
- (9) Decay of poles through butt-rot.

##### 2—TEST-STATIONS

On lines more than 15 miles long one or more test-stations should be established. These should be so arranged that the line may be looped into the house or building where the telephone is and through two switches placed near the latter. The instruments should be connected to these switches in a way to make it possible to cut off either end of the line, while the instrument remains on the end desired, and yet bridge to the line when both switches are closed. In this way the line may be cut by the switches for testing in either direction and line trouble may be more readily located between certain definite points.

By opening switch A, Fig. 92, the telephone is connected to one side of the line only. By closing switch A and opening switch B the telephone is connected to the other end of the line. By closing both switches A and B the line is in normal condition. Care should be taken after making tests that both of the switches are left closed, otherwise no calls can be sent through.

If desired, provision can be made at any point on the line for testing it in either direction with a portable telephone. In such cases the line wire should be cut and dead-ended from both directions on the same pole with a two-piece transposition insulator, or two brackets.

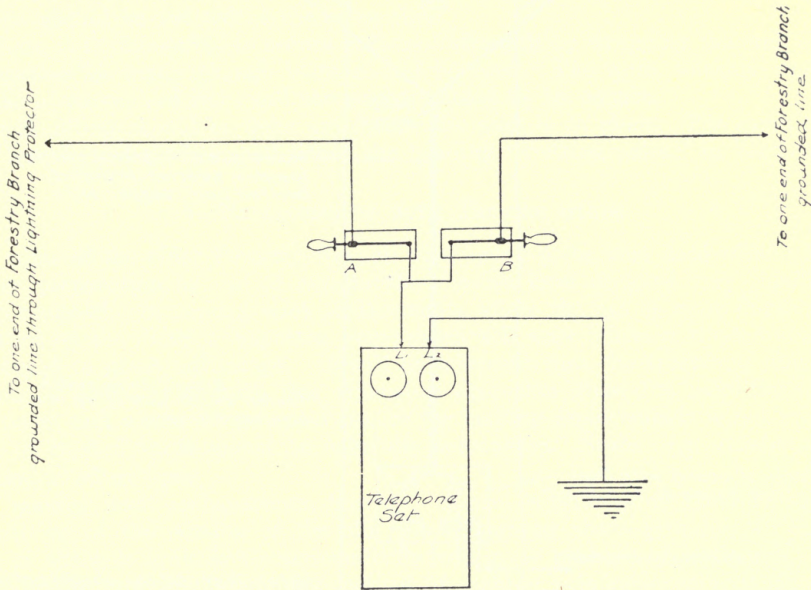

Fig. 92 Method of installing test-station indoors

The ends should be left long enough after dead-ending to be joined together with a test-connector, so as to complete the circuit, or a pair of switches may be installed as shown in Fig. 93 and joined to the line with insulated wire. Such stations, however, should not be placed where they are likely to be tampered with. In most cases it would be preferable to house the switches in a suitable box kept locked with a Forestry Branch standard padlock.

The voltmeter test-stations might be used at logical switching centres. The district inspector should be consulted, however, before equipment of this kind is purchased.

### 3—DISCONNECTING BRANCH LINES IN WINTER

Since any trouble occurring on branch lines to a lookout point or ranger station may injure the entire telephone system, such lines should be disconnected from the main line whenever they will be out of use for a considerable period, especially during the winter.

The disconnection from the main line may be made by a suitable pole-switch, properly mounted, as shown in Fig. 40. A Fahnestock test-clamp may also be used for this purpose as in Fig. 38.

### 4—STUB REINFORCEMENT FOR POLES

Poles that have become seriously weakened by butt-rot near the ground-line should be replaced, except where conditions are such as to warrant reinforcing them

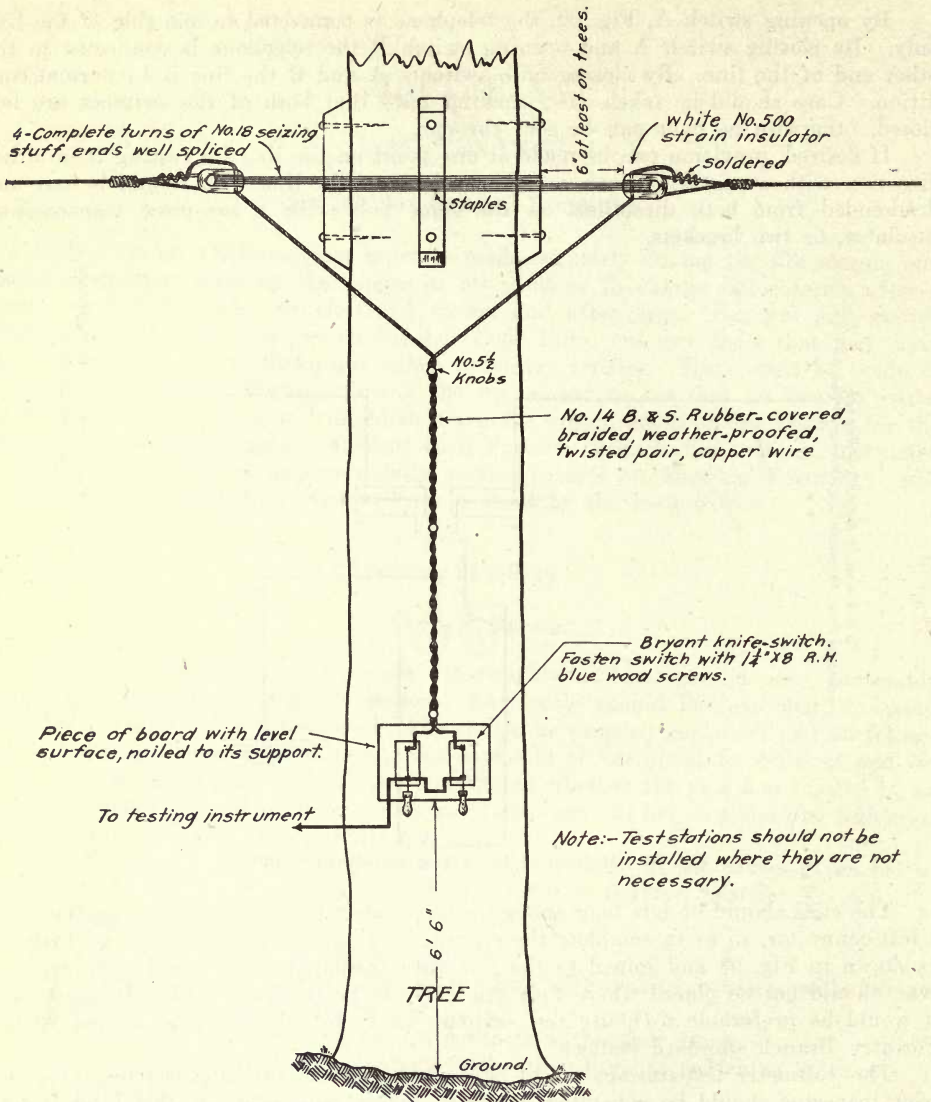

Fig. 93 Method of installing test-station on a tree

by means of a stub of long-lived or treated timber. A stub should ordinarily be used where suitable pole timber is not available and to reinforce poles that are sound above the ground, irrespective of their condition at the ground-line.

The stub or post should be peeled and shaved and roofed, as shown in Fig. 94.

The sides of the post and of the pole which come in contact should be faced above the ground-line to a width of 2 to 4 in., so as to give a greater bearing surface.

The diameter of the stub at the ground-line should be at least as great as would be required for a new pole. The weaker the pole to be reinforced the stouter should be the stub.

The stub should ordinarily be set to a depth of 4 ft. and should extend out of the ground about 5 ft., making the total length from 9 to 10 ft.

Strain on the weakened pole should cause it to bear against the stub. For this reason stubs in general should be set in line with the line wire. Where there are pre-

vailing strong winds from one direction, however, it should be set on the side opposite. On curves and at corners a stub should be set on each side of the pole in line with the line wire. Where any special strain exists, the largest post available should be used.

Wrappings consisting of No. 12 iron wire should be placed as indicated in Fig. 94. Each wrapping, consisting of eight turns around both pole and stub, should be made as tight as possible with pliers or other devices and the ends twisted together with not less than six turns and then stapled to the pole. The wires may be twisted very tight if an iron rod about  $\frac{1}{4}$ -in. in diameter or one arm of a pair of cutting pliers is inserted between an equal number of turns at a point opposite the line of contact. Both sets should be twisted at the same time.

Where it is impossible to secure sufficient strength by wrapping the stub and the pole together by wire, through bolts should be used. The nuts, washers, and bolts should be of galvanized iron, and the washers about  $2\frac{1}{4}$  in. square.

No back filling should be done until after the stub is in place. The same method should be followed as described under the heading "Setting poles," in Section 55.

#### 5—REPLACEMENTS WITH TREATED STUBS

In some of the older Forestry Branch lines many poles were used which through improper preparation or use of non-durable species have decayed very rapidly and must be replaced. In making such replacements where the use of more durable poles is specified by the district inspector, some cases will arise wherein treated stubs can be employed to great advantage. It will be apparent that the treatment and transportation of stubs is a much less expensive operation than the handling of full-length poles, and where durable pole timber for making replacements is not available, the use of treated stubs should be carefully considered. Stubs of a durable species have similar advantages.

In making such replacements, however, careful consideration must be given to the condition of the portion of the old pole remaining above ground. Unless this portion of the pole is in first-class condition and gives promise of lasting as long as the reinforcing stub employed, this method of making pole replacements should not be adopted.

#### 6—RESETTING OF SHORTENED POLES

The standard specifications for non-durable poles call for a 25-ft. length. Where such poles have decayed and it is desired to replace with durable poles, this object may frequently be attained economically by cutting off the decayed portion of the old poles, treating the sound portion remaining, and resetting the same in the line. This, of course, reduces the height of the lead and cannot be employed where such reduction is for any reason undesirable, but in most cases the reduction will still leave a 20-ft. pole and this will often be sufficient. Projects involving the treatment and resetting of shortened poles must always be reported to the district inspector and approved by him before being undertaken.

### Section 92—Apparatus

#### 1—GENERAL REPAIRS

All telephone apparatus at stations and elsewhere on the line should be carefully inspected for loose connections or other defects. The inspector should call up the terminal or intermediate stations from each instrument and note particularly how the generator of the instrument rings its own bell and how the bell rings at the station called.

The called station should ring back in order to test the bell at the calling station. In making tests it should not be taken for granted that something is wrong if an

answer is not immediately obtained. If unable to get the station after several attempts, call another station and try to get a test with it.

While the standard instruments and apparatus of the Forestry Branch are among the best made, and liability to trouble with their mechanism has been reduced to a minimum, nevertheless the conditions of use of forest lines are such that certain defects will develop from time to time and frequent, careful inspections are necessary to maintain the equipment at maximum efficiency.

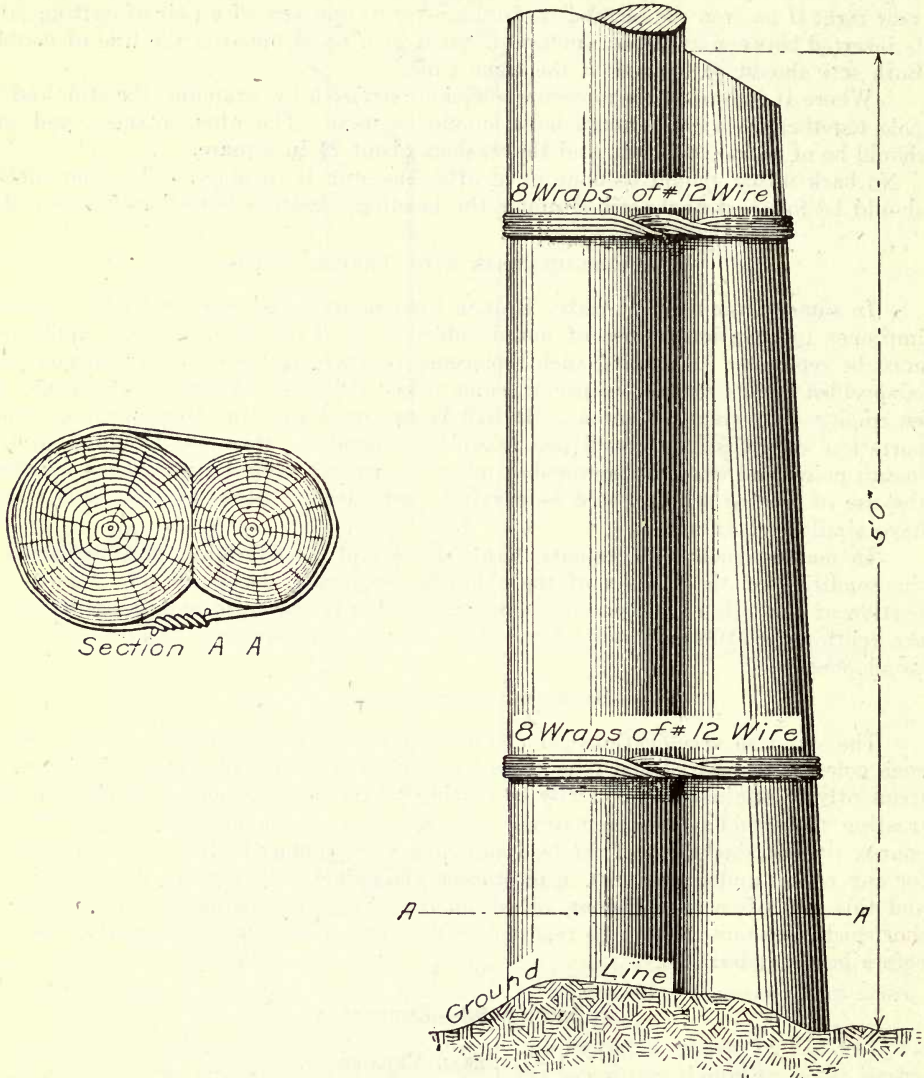

Fig. 94 Stub reinforcement of poles

The following list of faults taken from the circular of instructions issued by District No. 5 of the United States Forest Service will be of assistance to those who are not experienced in making thorough inspections of telephone apparatus:—

- All parts of receiver should be intact.
- Receiver cord should be intact.
- All nuts on receiver should be tight.

Receiver cap should be fairly tight.

Bent, dented, or rusted diaphragm of receiver should be replaced.

Dirt on or under diaphragm should be removed.

All wiring inside of instrument should be in good condition.

Generator should ring the bell clearly with switch open.

Generator crank should not bind when turned. When binding comes on gradually some operators do not know the difference. It is caused by grounds or lack of oil. Short circuits may cause either gradual or sudden binding of the generator.

Contacts of the switch-hook should be clean.

Generator should be fastened in the instrument securely.

Contact points of the generator (left side) should make good connection.

All screws inside the instrument should be tight.

Adjusting nuts on bell should be tight.

Resistance of all ringer coils should be the same.

Nuts on protector should be tight.

Protector blocks should be free from soot, smoke, or dust.

Protector blocks should be metal, not carbon.

Protector should be connected as shown in Fig. 45.

Protector should be screwed (not nailed) to wall.

Micas should not be cracked or otherwise injured.

Nuts on cut-off switch should be tight (if switches are installed).

Blades of cut-off switch should make good contact with springs.

Instrument should be screwed (not nailed) to wall.

Ground rod should be standard.

Ground wire should be soldered to ground rod.

Ground rod should be driven into ground within 8 in. of its full length.

Line wires and inside wires should be soldered where they connect with each other.

Splices in insulated wire should be taped.

Entering wires should run through circular loom or porcelain tubes.

All wiring outside should be insulated properly from buildings by being attached to knobs or insulators.

Insulation should be good on all inside wires.

All battery connections should be tight.

Transmitter arm should be screwed tightly to box.

Transmitter arm should be tight enough to hold it in proper position.

All nuts and screws on transmitter should be tight.

Metal parts of battery should not touch each other.

Are batteries good? Should be three.

The following instructions may be of value to officers who have occasion to test instruments and hunt for faults:—

(1) Test the batteries with the battery gauge to determine whether or not they are exhausted.

(2) Clean all battery connections, post terminals, and ends of all connecting wires that have become corroded. See to it that all battery terminals, nuts, or screws on the binding-posts are thoroughly tightened.

(3) Follow up the wires from the battery to the instrument. Repair them where damaged, and staple if they have become loosened.

(4) Tighten all loose connections in the telephone instrument.

(5) See to it that the switch-hooks work freely. Note carefully that a good connection between the contact springs of the receiver hook is made when the receiver is off the hook and the lever is up, and that the contact is broken when the receiver

is on the hook and lever is down. The operation of the switch-hook is sometimes subject to slight imperfections on account of improper working of the switch-arm. This is caused by the lifter spring of the switch-arm losing its tension.

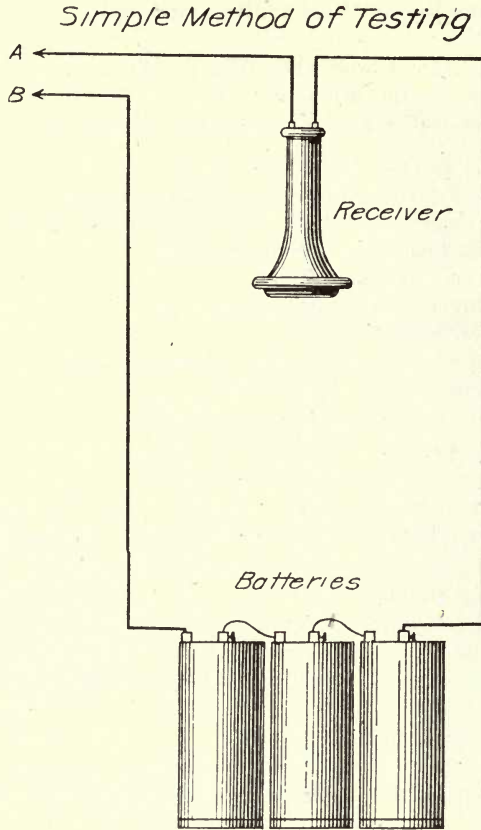

*Connect wire A to one side of coil to be tested and touch wire B to other side if click is heard coil is O.K.*

Fig. 95 Receiver test

(6) Inspect the ringer to determine whether or not the tapper and gongs are in proper adjustment. If not, proceed to adjust them as directed in Section 92. Also refer to Fig. 96.

(7) Gently tap the transmitter to be sure the carbon granules are not packed.

(8) The Receiver. The efficiency of the speaking service gradually declining is the most common fault in receivers. This is due to the accumulation of filings, dirt, and rust on the pole pieces which restricts the vibration of the diaphragm. To remedy this difficulty remove the cap, take off the diaphragm with the large end of the receiver down, and gently jar the receiver to remove the filings, etc. The pole piece should be carefully wiped with a clean rag to remove dust, and rust if it is corroded.

(9) Speaking service is also often restricted on account of the diaphragm touching the pole piece. This is generally caused by the magnet shifting, or by the diaphragm having become weakened by the continual pull of the magnet against it. Buckled or bent diaphragms are frequently found. This trouble is generally caused by inquisitive or careless persons tampering with the diaphragm. When this fault



is found, temporary relief may be provided by inverting the diaphragm when it is replaced. A new one should always be provided as soon as possible.

(10) The receiver casings are sometimes damaged by expansion and contraction due to changes of temperature. This sometimes causes receiver trouble, which can be remedied only by supplying new casings.

(11) Inspecting the receiver cord. If the ends are frayed a short circuit often results. If the receiver cord is suspected of being broken it should be removed and tested. It is often very difficult to detect a break in the receiver cord, since it appears intact at one movement, while at the next its continuity is broken. If such difficulty is suspected a new one should be provided.

(12) Receiver coils are occasionally fused or burned by electrical currents during lightning storms. When this happens new receivers must be provided.

(13) The wires of a telephone instrument frequently become damaged, and break. When this occurs it is sometimes possible to detect the trouble only by testing with a buzzer or by the "receiver test." If the wires are intact the buzzer will hum when the wires of the buzzer apparatus are attached to the respective ends of the suspected wire. If the receiver test is applied a click will be heard when the end of the wires leading from the receiver apparatus are applied to the respective ends of the suspected wire.

(14) Induction coils. Fortunately, faults in induction coils seldom occur. They are, however, not immune from damage and sometimes are burned by electrical currents during lightning storms, or if the line wire leading to the instrument comes in contact with transmission lines carrying high-voltage currents. When damaged, a new one must be supplied.

A word of caution, however, must be spoken in regard to the tampering with telephone apparatus of those who are entirely inexperienced and ignorant of the mechanism of the equipment. Hasty action may cause much more serious difficulty than that which it is undertaken to correct. Repairs should be undertaken cautiously. If the apparatus does not work well do not meddle with it until you have located the seat of the trouble and know just what to do to correct it. If the fault cannot be found, the instrument should be removed and placed in the hands of an expert for repairs.

In most cases it is advisable to send the instrument to the nearest office of the manufacturer. To enable this to be done without interruption of the service, one or two extra instruments should be kept on every forest reserve and installed temporarily in the place of any that are undergoing repairs.

## 2—BATTERIES

All dry batteries on the line should be replaced at least every twelve months, and more often if necessary. As far as practicable, all the batteries on a line should be renewed at the same time, preferably at the beginning of the fire season. A fresh battery should not be connected to an old one. The inspector should note whether or not battery connections have become loosened. In putting dry batteries back into a telephone, the inspector should see that the zinc binding-post on one cell does not touch the zinc binding-post on an adjacent cell (Fig. 43).

An emergency test to determine whether or not a dry cell is absolutely dead may be made by moistening the finger and gripping the zinc binding-post, and then touching the tip of the tongue to the carbon binding-post. If a very slight acidulous taste is noted the cell is not absolutely exhausted, although it may be sufficiently so to be incapable of giving good transmission. In extreme emergencies exhausted dry cells can sometimes be temporarily revived to give sufficient current for sending an important message over the line by driving holes with a nail through the zinc shell and allowing water to soak in through them.

Lightning-protectors should be inspected, and cleaned if necessary, after all electrical storms. No. 60-E protector is cleaned by unscrewing the brass cap from the porcelain base, removing the metal protector blocks, and removing from them any soot or smoke or pits which cause the blocks to touch each other. Both conditions are the result of lightning jumping across the air gap provided by the mica sheet. In localities where lightning is particularly bad and the stations are difficult of access two micas may be inserted between the blocks, thus increasing the width of the air gap.

### 3—OILING GENERATOR

Once every two or three years one drop of typewriter oil or "3 in 1" should be placed in each of the places provided with oil cups. Great care should be taken to see that no oil falls on any of the contacts or rubber bushings of the generator.

### 4—ADJUSTMENT OF RINGERS

(The following is from Telephone Circular, April, 1916, United States Forest Service, District No. 5.)

Ringers not in proper adjustment cause unsatisfactory signalling service. Not infrequently an extension bell or ringer in a telephone is condemned as worthless, when in fact it is merely in poor adjustment. When in proper adjustment either gong, upon one-eighth turn of the generator crank, will transmit a high, clear tone of the same sound.

All bells connected to the same line should be of the same ringer resistance. One ringer of different resistance on a line will seriously interfere with signalling. Resistance of each ringer coil is usually marked 800, 1000, 1250, etc. A ringer having two coils marked 1000 each has a resistance of 2000 ohms; two coils marked 1250 each indicate a resistance of 2500 ohms.

The ringers of a new instrument are often thrown out of adjustment in transit. When the telephone is installed the ringer should be tested and adjusted if necessary.

(a) *Adjustments.*—(1) If the ringer is loose on its base, remove the gongs and tighten the screw which secures the ringer mounting. Replace the gongs and securely tighten the gong screws.

(2) Before commencing the adjustment, the instrument should occupy the position in which it will be operated. If it is connected to a line, disconnect it.

(3) If a coil spring should be found attached to the ringer, remove and discard it.

(4) The base of the clapper rod (the armature) should have very little vertical play. It should not be tight but should not wobble. It should be adjusted to move freely on the pivots. In making this operation pay no attention to the side movement of the armature. To adjust, loosen the lock nut D (Fig. 96), then manipulate the screw E until the proper adjustment is accomplished. Tighten or loosen to provide just sufficient play in the armature pivots to be visible.

With the screw-driver hold the screw in place, and with a pair of long-nosed pliers tighten the lock nut. Care should be taken that the threads are not stripped in this operation and that the screw does not turn. *Only a slight pressure should be applied to the lock nut.*

The gongs should next be so set that the clapper ball strikes but does not rest against them when thrown from side to side. The space between the clapper ball and one gong should be about  $\frac{3}{16}$  in. when the clapper ball is held against the other gong. To change the positions of the gongs loosen the clamping screws B only enough to allow the gongs to be moved by the turning of the eccentric adjusting screws C until the correct position of the gongs is obtained. Let the clamping screws remain loose until the stroke of the clapper is adjusted. To make this adjustment turn the screw A to the right to shorten the stroke, and to the left to lengthen it. Turn the generator handle only enough to cause the clapper to move toward one

gong but not to strike back to the other gong at each movement of the handle. The clapper ball should strike the gongs and rebound just enough to clear the gong. It should lie as close as possible without touching the gong.

Sometimes the clapper ball tends to rest heavily to one side. If possible the difficulty should be overcome by moving the *gongs* or by changing the length of the stroke of the clapper. If the attempt is not successful, bend the clapper rod until the required space is obtained. Then move the gongs to their proper relative positions.

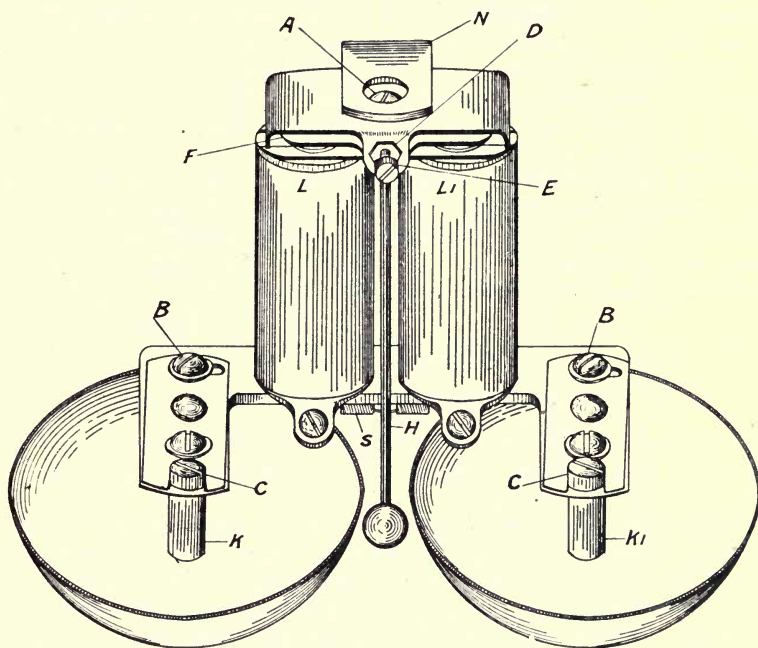

Fig. 96 Ringer of No. 127-F, extension bell, and Nos. 1317-P, 1317-S, 300-N and 1336-J telephones

(b) *Testing*.—When the gongs and clapper ball appear to rest in their proper positions, test the adjustment by turning the handle of the generator until the clapper ball strikes one gong without striking back to the other. If the tones are not satisfactory, continue the adjustment until a clear ring of the same tone is emitted by each gong, and at the same time the stated spaces between clapper ball and gongs must be maintained. The clamping screws B should be tightened when the adjustment is complete.

Adjustment of ringers in extension bells differs only in method of testing. The test is made by slowly and slightly tipping the ringer from side to side. It should not be jarred.

The 292-U loud-ringing extension bell can be more successfully adjusted when it is connected to a line. This allows the adjustment to be tested by signalling to it from some distant telephone. The bell should be installed in a true vertical position; with the clapper pointed either upward or downward.

The coil to which the clapper is fastened should move freely between the upper and lower pivot screws, but not loosely. This adjustment is made by manipulating the screws on either side of the armature. The space between the clapper ball and gong should be about  $\frac{1}{8}$  in. when the clapper ball is held against the other gong. The gongs are adjusted by loosening one at a time the square-headed screws on the face of the gong, turning the gongs to the proper position and then tightening this screw

before each test. The distance between the clapper ball and the gong after rebound of the clapper ball should be approximately  $\frac{1}{16}$  in. If in proper adjustment, each gong when struck by the clapper should emit a clear, ringing sound.

### 5—PORTABLE TELEPHONES

The two standard portable instruments, the 1375-A and the 1004-A, are so constructed that they are very unlikely to give trouble unless tampered with. Owing to the small size of the battery employed in both these telephones it is necessary to make more frequent renewals than in the permanent sets. No adjustments are required in the 1375-A set, but in order to get the best results from the buzzer of the 1004-A set it is sometimes necessary to alter the spark gap. This should not be attempted in the field, and any instruments not working satisfactorily should be returned to the district inspector for repairs.

The 1004-A hand set and the hand set of the 1375-A instrument being of rather thin sheet aluminium are very liable to serious injury through denting. Such dents may cause short circuits which interfere with the successful use of the instruments. When these occur they may often be removed by pressing out from the inside, using a smooth piece of hardwood with a rounded surface.

### Section 93—"Trouble"

#### 1—BROKEN CONNECTIONS AND OPEN COILS

In the instruments that the Forestry Branch has adopted as standard the chances for trouble have been reduced to a minimum. Lightning is the greatest source of trouble.

The ringer coils, which are constructed of fine insulated wire wrapped around an iron core, occasionally burn out. When this happens it is necessary to substitute a new coil. The armature in the generator may also burn out, necessitating replacement. (The armature is the part in the generator that revolves between the permanent magnets. This is composed of two windings around an iron base on opposite sides of the centre. The generators used on some sets are protected to a certain extent by means of a "shunt.")

In the receiver the small coil of insulated wire wrapped around the end of the permanent magnet is sometimes burned out by lightning or heavy outside currents. The induction coil is sometimes similarly damaged.

The following methods of testing may be used to locate trouble as just described: Connect one side of a receiver to one pole of the battery. If when the other side of the receiver is touched to the other pole of the battery no click is heard, the receiver is open.

By the use of a receiver, if in serviceable condition and the batteries as shown in Fig. 95, any of the wire coils may be tested.

A test of the generator may be made by disconnecting the instrument and placing the moistened tips of two fingers over the two screw binding-posts on the end of the generator. If the latter is in adjustment, current will be felt when the crank is turned. If no current is felt probably the armature of the generator is open, and a new armature must be obtained. The hard-rubber bushings sometimes carbonize, due to oil or grease getting on them, and cause generator trouble.

It is impossible to talk through the transmitter when the induction coil is open, when the batteries are weak, or when there is a loose connection somewhere in the instrument, as at one of the connections on the batteries or at the switch-hook.

#### 2—DETECTION AND REMEDY

Trouble in any place is likely to affect the entire system. Inexperienced persons should not be allowed to tamper with telephone instruments. It is usually well to

have a spare telephone on each reserve, which can be temporarily installed while a telephone or the part of it that is out of order is sent to some reliable telephone man for inspection, repair or readjustment.

In general, telephone trouble may be in connection with (1) signalling or (2) talking and hearing. The generator furnishes current for signalling or ringing the

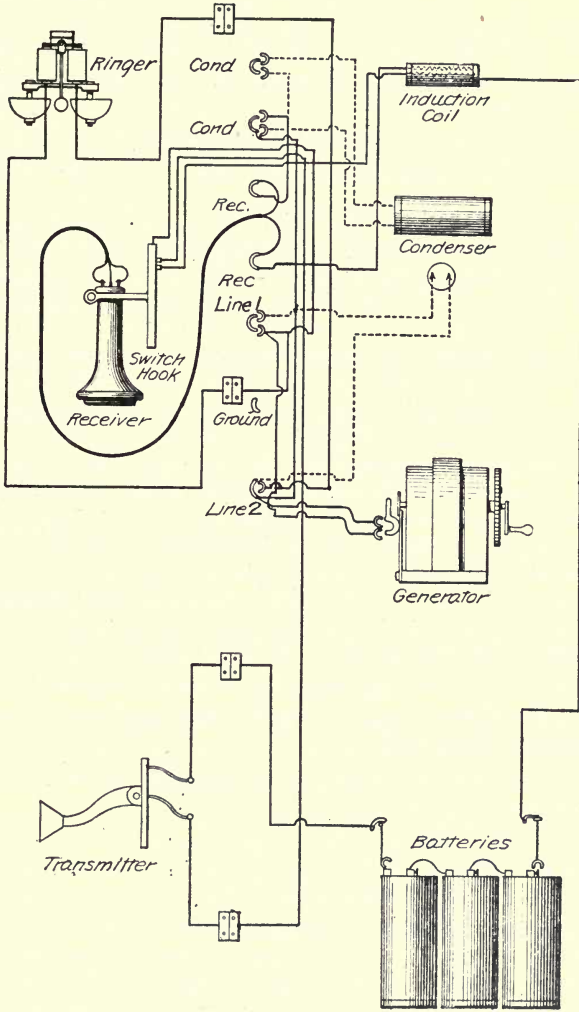

Fig. 97 Wiring of No. 1317 telephone set

bells, sending a current over the line to all bells on its way to the ground. The generated current is intermittent, and jumps to the ground or is greatly weakened by groundings instead of flowing along the line. The batteries furnish current for conversation only. It is possible to talk over a wire even when there are slight grounds through trees or through the line wire touching the ground in dry places, but it is not possible to signal.

### 3—GUIDE TO CLEARING TROUBLE

**Trouble No. 1, Bell—Cannot ring up anyone; generator handle turns hard; local bell does not ring when generator is turned.**

*Cause.*—Protector burned out or dirty. Line wire grounded or wires crossed (if metallic); improper wiring in set or bushings on generator carbonized.

*Remedy.*—When testing to discover the cause of this trouble the receiver should be left on the switch-hook. First disconnect the two wires which enter the telephone set from the terminals marked “Line 1” and “Line 2,” (see Fig. 97) and screw down the connections on the wires coming from the ringer. Now turn the generator. If it turns easily and the bell rings well, the trouble is not in the telephone set.

Then connect the line wires to “Line 1” and “Line 2” terminals and disconnect the line wires from the protector, leaving the inside wires to the telephone set attached to the protector. Now turn the generator handle. If it is difficult to turn, remove the protector blocks from the protector and try the generator again. If it turns easily, clean the protector blocks, replace the thin piece of mica between them, and put back into the protector. Now test the generator again, and if it turns properly connect the line wires to the protector and see if the telephone set works as it should.

If the generator turns properly when the line wires are disconnected at the protector, but is difficult to turn when the protector blocks have been cleaned and the line wire again attached, the trouble is either in the wiring between the protector and the pole, or out on the line, or in the wiring apparatus at one of the other stations. Carefully examine the wiring and the line for a place where one of the wires crosses another (if the line is metallic) or where the main line or drop wire touches some ground connection. If in a metallic line the wires are crossed, the generator crank will turn hard as above described. This is also true of a grounded line if the wire becomes crossed with some foreign ground. On a metallic line, if one side of the wire is touching a ground, a humming noise will be noticeable on the line.

If the generator turns hard even when the line wires are disconnected from the telephone, look for incorrect wiring or crossed wires in the set or for carbonized bushings on the generator. When this latter trouble exists the odour of burning rubber is noticeable when the door of the telephone is opened.

If every station on the line has the same trouble, call for an inspection of the protector at each station, or look for trouble along the pole line or in the terminal arrangements where the line is connected to a switchboard or to another line, and inquire on that line, if necessary, or disconnect from it temporarily.

**Trouble No. 2, Bell**—Cannot ring up anyone; generator handle turns easily; local bell rings when generator is turned.

*Cause.*—Loose connection or broken wire in set, to protector, line or ground; line wire broken, or poor ground.

*Remedy.*—If a metallic line, look for a loose connection at “Line 1” and “Line 2” of the telephone set. If a grounded line, look for a loose connection on the main line at “Line 1” or on the ground wire which is attached to “Line 2” in the instrument. Look for a loose connection at the protector or where the inside wiring is attached to the outside wires. Look for an open fuse. If the trouble is not found at these points look for a broken wire or a poor ground.

**Trouble No. 3, Bell**—Cannot ring up anyone; generator handle turns easily; local bell does not ring when generator is turned.

*Cause.*—Loose connection or broken wire in set, generator armature fails to make contact with spring.

*Remedy.*—Look for a loose connection or a broken wire in the telephone set. See that your ringers are in proper adjustment. It may be that one of the wires to the generator is disconnected from one of the line wires, or one of the ringer wires may have become loose or broken.

**Trouble No. 4, Bell**—Cannot ring other bells or only feebly; local bell rings all right when generator is turned.

*Cause.*—Loose connection between telephone and line or ground; poor joints on line or leaks; poor grounds.

*Remedy.*—Look for a loose connection where line connects with telephone set, where line connects to protector, or at the ground. It is possible that the trouble may be due to a poor or corroded splice in the line wire or to contact between the line wire and trees, poles, or other lines. In the case of grounded lines be sure that the ground at the telephone you are trying to call is in proper condition. Be sure that your own ground is in the same condition.

**Trouble No. 5, Bell—Local bell does not ring; can ring other bells all right.**

*Cause.*—Broken wire or loose connection to ringer, ringer adjustment bad, or coils open.

*Remedy.*—Look for a broken wire or loose connection in the wires coming from the ringer. If the connection and wire are all right, see that the ringer is properly adjusted. Make a test on your ringer coils to see that they have not been burned out as previously described. If only a feeble ring is received from other stations or when ringing your own bell, the trouble is most likely with the adjustment of the ringer which has probably been tampered with. Occasionally the ringer magnet becomes weakened and causes a similar result.

**Trouble No. 6, Bell—Can ring other bells only feebly; receives a strong ring from other stations.**

*Cause.*—Weak magnets or bad connection in generator.

*Remedy.*—This may result from weakness of the permanent magnets of the generator, but it is more likely due to a poor connection between the generator and the line. If not in the wiring there may be faulty connection between the shaft of the armature and the spring against which it presses when the generator is turned. This contact must not be oiled. Oil at this point offers a high resistance that greatly reduces the ringing current.

**Trouble No. 7, Bell—Rings frequently with no apparent cause.**

*Cause.*—Intermittent cross with foreign lines.

*Remedy.*—This trouble can only arise where the line is on the same poles as a foreign telephone or telegraph line. If it makes a contact with such other wires by swinging across them the bells will be rung but there will be no response.

**Trouble No. 8, Transmitter—Can hear others all right but others cannot hear you.**

*Cause.*—Loose connection or broken wire in primary circuit; carbon packed; battery weak; speaker standing too far from transmitter.

*Remedy.*—Look for a loose connection or broken wire coming from the transmitter battery, induction coil, or switch-hook. See if the connections to the induction coil are all right. If this examination does not show anything wrong, thump the underside of the transmitter lightly with the hand, as the carbon granules in the transmitter may have become packed. If this fails to improve matters the trouble may be due to an exhausted battery.

If speech transmitted is indistinct with a scratching or grating noise, look for a loose connection at the battery, induction coil, or in the fine wire connecting the carbon of transmitter to the cord terminal.

**Trouble No. 9, Receiver—Cannot hear others distinctly; others hear you all right.**

*Cause.*—Loose connection on receiver circuit; diaphragm bent or dirty.

*Remedy.*—Look for a loose connection or broken wire coming from the receiver, switch-hook, or induction coil. Unscrew the ear-piece from the receiver and brush out the inside and wipe off the diaphragm. Also brush off any particles that may have collected on the magnets underneath the diaphragm. If the diaphragm is bent in, turn it over and replace the ear-piece. Screw this on firmly, but not very tightly.

If this does not reveal the cause of trouble, unfasten the receiver cord from the terminals in the telephone set and, while holding the receiver to the ear, touch the two terminals of the receiver cord to the terminals of one of the dry batteries. If you can hear a click when the cord is connected thus, the receiver is all right and there must be some fault in the wiring. If you do not hear a click, it is probable that the receiver winding or the cord is broken.

If you cannot hear at all, the fault is due to a broken wire in receiver or cord.

**Trouble No. 10, Neither you nor others can hear distinctly.**

*Cause.*—Poor joints or connections, batteries or grounds.

*Remedy.*—The trouble is probably due to some loose connection or poor or corroded joint in the wiring at the telephone station or out on the line, exhausted batteries or poor grounds or a loose lightning-rod touching the line.

**Trouble No. 11, The stations at the terminals of the lines have increasing difficulty in ringing or hearing each other plainly.**

*Cause.*—Too many stations on line; too long a line for size of wire used; ground rods in too dry soil; corroded splices; poor joints; excessive line leakage through contact with trees, poles, or foliage.

*Remedy.*—Fix up the entire line. If this improves the talking but not the ringing, see that all the telephones on the line have 2,500-ohm ringers. See that the generator crank-shaft comes back into place after calling a station on the line. If this does not make the ringing satisfactory, cut off some of the stations or divide the line into sections, or rebuild the main line, using heavier wire. In extreme cases it may be necessary to build a copper, metallic circuit. The fault may be due to similar conditions or poor maintenance on a foreign telephone line or switchboard to which the Forestry Branch line is connected.

#### 4—CROSS-TALK

Cross-talk occurs when two grounded lines are strung on the same poles. This interference with conversation is reduced as far as possible on a grounded line by good grounds at all subscribers' stations. Separate ground rods should be used for separate lines. If it is desired to eliminate cross-talk, the circuit must be made metallic and the standard method of transposition followed. By making one of the two lines metallic, cross-talk is eliminated on the metallic line but may still cause trouble on the grounded line. Cross-talk will not generally arise unless the Forestry Branch line parallels a second grounded or metallic line, closer than 30 ft., for a distance of more than a quarter of a mile.

#### 5—STATIC ELECTRICITY

A great deal of inconvenience may be caused by static electricity. There may be no trouble in the morning, but toward noon a frying noise is apparent and in the evening it is impossible to carry on a conversation. Trouble from static electricity is usually greater at high altitudes than at low.

One method of removing static electricity from a line is by the use of a lavite coil with a resistance of 48,000 ohms. This coil should be installed along the line at intervals of from 3 to 10 miles, and attached to a grounded line as shown in Fig. 51. In a metallic line two coils should be attached, one to each wire. The same ground may be used for both coils. The coil should be inclosed in a small weather-proof box.

Another method of draining static electricity is by the installation of vacuum lightning-protectors. These protectors should be installed in the same manner as the lavite coil, except that the fuse may be omitted.

It is sometimes necessary to make a study of static conditions, as the distance between coils is not the same in all cases. Before doing so the district inspector should be asked for definite instructions.



## CHAPTER XVII

### TELEPHONE "DON'TS"

#### Section 94—Construction

Don't build telephone lines without a systematic plan based on a careful study of all the existing conditions and probable developments.

Don't fail to get a right of way over private lands before starting construction; also a permit to cross all railways and power-transmission lines.

Don't start to build a telephone line until you have all your supplies on the ground.

Don't use unseasoned poles. Prepare your poles a year in advance of construction, if possible.

Don't use short-lived poles of such species as poplar, spruce, or lodgepole pine, unless treated with a preservative, except where such use is specifically authorized by the Director.

Don't put creosote or other preservative on green poles nor on wet or frozen poles.

Don't use unpeeled poles or poles without a roof ridge.

Don't use iron wire smaller than No. 9 B.W.G. for tree lines in any case or for pole lines without special authority.

Don't try new methods of constructing tree lines until you have had experience both in building and maintaining lines in the way specified in this manual. These methods are the result of years of experience by hundreds of men, and the chances are your new scheme was tried and abandoned years ago.

Don't cross roads or trails with lines if you can possibly avoid it.

Don't put telephone wires on the same poles with electric-light or power-transmission lines.

Don't put grounded lines on poles with any other wires whatever.

Don't run a tree line nor a grounded line near a high-tension transmission line.

Don't use sleeve connectors to make splices on iron wire and don't make splices any other way on copper wire.

Don't string wire in a lightning storm.

Don't try to pay out wire from a coil without a reel.

Don't leave the cross-bar, used as a hand-hold in pulling wire, attached to the wire after the coil is pulled out.

Don't drag copper wire along the ground as you do iron wire nor throw the coils from cars or wagons.

Don't let any kind of wire lie out on the ground where horses or wagons may run over it.

Don't nick the line wire with your pliers nor burn it in making ties.

Don't guy to bushes or saplings or driven stakes. Use standard methods.

Don't attach any guy to the ground at a point nearer than 8 ft. from the base of the pole and preferably at a distance from the base of the pole equal to the distance from the ground to the lower bracket.

Don't put unguarded guy wires on a public road or street.

Don't put brackets on poles or curves so that the line wire pulls away from the pole.

Don't put split insulators on trees on curves so that the line wire pulls toward the tree. Always with split insulators have the pull away from the tree or other support.

Don't use brackets and glass insulators on trees.

Don't use tight ties on the occasional poles used in tree lines to cross meadows or other openings. Consider them as trees.

Don't pull a tree line tight. Leave at least 4 ft. of slack, more where possible.

Don't use Buffalo grips on tree lines. Pull all slack by hand.

### Section 95—Installation

Don't have any more inside wiring than is unavoidable. Determine the best permanent location for the telephone and bring the wires through the wall as near this point as possible.

Don't install telephones or extension bells of different resistance ringer coils on the same line. All coils must be alike.

Don't put the standard indoor telephone set in a damp place nor where it may be exposed to the weather. The metal-covered set has been adopted for such places.

Don't under any circumstances connect up an instrument without a protector. The first lightning storm may ruin it.

Don't fail to fasten the tension cords on both ends of the receiver cord when attaching the latter to receiver and interior binding-posts. This prevents strain on receiver-cord conductors and saves breakage.

Don't attach any of the equipment with nails. Use only wood screws of the proper size and type.

Don't expect a slipshod job of wiring to work satisfactorily. A good workman takes pride in the appearance of his work as well as in its working qualities. A poor-looking installation is practically always a poor-working one also.

Don't put two wires under one staple. Use insulated staples only and fasten each wire separately.

Don't run wires near metal pipes or drains.

Don't leave exposed joints in the wiring. Solder and tape properly.

Don't run unprotected wires through the chinking or between the logs of a log-house. Bore holes through a log and put in porcelain tubes.

Don't think you can make a good ground on any old iron rod or piece of wire or junk that may come handy. Any iron not galvanized will rust and this rust is practically a non-conductor. Use only *galvanized* iron, or copper, with as large a surface as possible, making a moist contact with the earth.

Don't expect to get a good ground except in *permanently* moist earth. This means earth, not rock, and it means earth that neither dries out nor freezes.

### Section 96—Operation

Don't try to ring with the receiver off the hook.

Don't ring in on a line until you have both "listened in" and also inquired if the line is busy. The line may be in use even though no one is talking when you "listen in".

Don't think because the station called fails to answer on the first ring that the line is broken or nobody at home. Have some nearer station try to raise the person wanted. Learn the habits of your man. He may be out after his horse or getting in a supply of water for the day. Be persistent.

Don't forget to ring off after talking. There may be others waiting for you to finish your conversation.

Don't be too ready to blame operating trouble on the instruments. Nine times out of ten trouble is due to the condition of the line, the ground, or the installation. Also nine times out of ten, if the instrument *does* get out of order, the fault lies with the person using it and is due to carelessness or ignorance.

Don't experiment with the interior mechanism of the instruments. Learn all about the telephone and you won't have to experiment.

Don't stand too far from the transmitter when talking. Talk from two to six inches only from the mouthpiece and directly into it.

Don't shout into the transmitter. Enunciate distinctly and directly into the transmitter. Clear enunciation, properly placed, transmits better than loud tones.

Don't hang the receiver with the diaphragm up. This simply serves to collect dust. If the switch-hook is too big to hold the base of the receiver make it smaller by bending the arms together.

Don't tap on the diaphragm of either transmitter or receiver with a pencil or other article. If the receiver diaphragm is bent, get a new one. It can be removed by unscrewing the hard-rubber cap of the receiver.

Don't drop the receiver. The shell is hard rubber and brittle.

Don't leave the receiver off the hook for long periods. This exhausts the local battery. With portable outfits having push-button on hand sets, be sure the push-button is not depressed when you pack the set for transportation.

Don't open the door of the telephone out of curiosity and then forget to fasten it again.

Don't allot signals to stations promiscuously. It saves time and patience to give the stations most frequently called the shortest signals.

Don't fail to post a copy of the "Operating Rules and Station Calls" at every station, close beside the instrument. This includes outdoor stations, also.

Don't expect a line through timber to maintain itself. If you *must* have a line with the minimum of maintenance, cut a 100-ft. right of way and build a standard pole line.

### Section 97—Maintenance

Don't try to maintain lines without systematic tests. Test daily to all stations and correct immediately all breaks or other line or station troubles.

Don't fail to make at least one general overhauling a year; two are better.

Don't let fallen trees accumulate across tree lines. Keep them cut out and make it the duty of every forest officer always to clear the line of trees encountered on patrol.

Don't fail to inspect and clean lightning-protectors after every electric storm.

Don't put paper between the protector blocks. Keep a few extra micas on hand for repairs at each station. Also a fuse or two.

Don't fail to put in new batteries at least annually; more often if necessary. With portables using small flash-light batteries, get fresh ones every two months.

Don't replace batteries one cell at a time. Put in an entirely new set.

Don't buy batteries locally unless you can get standard telephone batteries and can test them. Motor ignition batteries are the usual kind at local supply houses and are not so good for telephones as the special brands. Get your batteries regularly from telephone dealers.

Don't forget that dust is prevalent in many forest cabins and that its accumulation on the parts of the instrument and its accessories is injurious. Keep them clean.

Don't expect binding-posts and other non-soldered connections to remain tight and clean indefinitely. They all have a tendency to work loose, and often corrode, and should be fixed up occasionally.

Don't try to make repairs to delicate parts of the instrument unless you are an expert. Send it back to the factory and substitute a spare telephone in the meantime.

Don't oil the hinges of the box.

Don't oil any part of a telephone unless you have the proper equipment for doing so and know where to put the oil. Improper oiling will ruin the generator.

Don't climb old poles without testing to make sure they are not rotten at the butt.

Don't hesitate to pour water around your ground rod frequently.

## PART III

### FOREST PROTECTION HELIOGRAPHS AND OTHER SIGNALLING APPARATUS

#### CHAPTER XVIII

##### HELIOGRAPH

###### Section 98—The Instrument

The heliograph is a visual signalling device consisting essentially of a plane mirror and certain auxiliary equipment by which flashes of light reflected from the mirror may be directed toward any given point. For purposes of communication these flashes are generally made to form the symbols of the telegraphic code, a short flash representing a dot; a long flash, a dash.

The heliograph is almost exclusively used as a daylight signalling device only and requires full sunlight for its successful operation. Within certain limits, which will be hereinafter discussed, the heliograph is, next to the telephone, the most useful communication device that is at present available for forest-protection purposes.

Heliographs are of two main types:—(a) Moving flash; (b) Fixed flash.

The first type is represented by the British Army heliograph. The second type is represented by the United States Army and the United States Forest Service heliographs.

###### Section 99—Use in Forest Protection

Although the heliograph has been used by the army for the purposes of communication for a great many years, its use in forest protection is a recent development. So far as is known, this instrument was first employed in forest protection for communication between lookout stations under the direction of the author on the Kaniksu National Forest in Idaho in 1909. This successful demonstration of its utility has been followed by a slow but widespread adoption of the instrument for certain restricted uses on a large number of the National Forests of the United States, and at least one instance of its use in Eastern Canada has been noted. The recent invention by Supervisor D. P. Godwin, of the United States Forest Service, of an improved form of heliograph for forest protection purposes, promises to enlarge greatly the sphere of usefulness of this instrument. While realizing fully the limitations of the heliograph, especially for use in the East or in a flat country, the author believes that its capabilities for enabling the members of a specialized forest-protection staff to maintain intercommunication are very far from being fully utilized or even appreciated.

Heliograph stations as employed in forest protection are of three classes: permanent, semi-permanent, and temporary.

Permanent stations include mountain lookout stations or other fixed points in the forest improvement system where signals may be sent or received with a high degree of dependability during all or part of the fire season. Lookout stations are, from their location and use, heliograph stations of the very first importance, since they not only have a wide range of country constantly under observation but may themselves be picked up with little difficulty from most of the area within their range.

Semi-permanent stations are those established at or near temporary camps such as fire, survey, or construction camps or near ranger stations that are not connected to the telephone system. Stations of this class will likely be occupied for signalling

purposes during only a limited portion of the day. While their dependability for sending purposes may be high, they are not adapted for receiving messages except during the periods when they are actually occupied. Such periods may be regular or not, according to the facilities and organization in each case.

Temporary stations are those established by moving patrol or other moving units of the forest force merely for the purpose of communicating with some other station in the forest. As a rule they will be used for sending messages only and will have little or no value as receiving stations, since they will seldom be occupied regularly but will generally be established only as the moving unit finds it necessary to communicate with headquarters or some other station.

It is obvious that in the first two cases the element of easy portability is of much less importance than in the third. At the most, a heliograph outfit, even of the largest size, is quite easily carried by one man, so that where it is simply a question of setting up an instrument in a suitable location at a permanent or semi-permanent station, any of the usual types may be employed. No special heliograph equipment is therefore needed for lookout or headquarters use but, as rigidity is an element of some importance and as range is governed by the size of the mirror, one of the heavier models should be selected and the size determined by the ranges over which it is desired to work.

When, however, the heliograph is to form a part of the outfit carried by a foot or horse patrolman the question of size and weight becomes extremely important. Such patrolmen are usually loaded to their carrying capacity with tools and supplies requisite for their work, and every item of their equipment must be reduced to the lowest practicable weight. The ordinary military heliographs even of the smaller sizes are too heavy and too bulky to be made a part of the outfit of either a foot patrolman or horse patrolman, though they might be used by canoe patrol where few portages are necessary, and may be easily carried on any wheeled vehicle used in forest protection except a motor-cycle. This difficulty would seem to be successfully overcome by the new Godwin heliograph described herein.

In general the heliograph will find useful application to forest protection intercommunication in the following ways:—

- (1) Before the construction of the telephone system, to furnish communication facilities to all parts of the forest.
- (2) As a substitute for an emergency telephone line, operating from temporary camps to lookout or other permanent stations on the main telephone system.
- (3) As an emergency equipment at all permanent lookout stations to ensure against isolation of the station in the case of a break in the telephone line.
- (4) As a cheap substitute for a telephone on secondary lookout points occupied during a limited portion of the fire season or during an unusually dry season only.
- (5) As a cheap substitute for a telephone on lookout peaks which it has not yet been decided are entirely suited for permanent occupation.

### Section 100—Range and Speed

The range over which the heliograph can be operated depends on the size and perfection of the mirror, the brightness of the sun, the clearness of the atmosphere, and, to a much smaller degree, upon the angle at which the light is reflected from the mirror and the background against which the signals are seen. While the normal working range of the 4½-in. square or 5-in. round mirror heliograph is about 40 miles, either may be read by the naked eye under ordinary conditions at 50 miles without difficulty, and up to 90 miles with a glass. In the clear atmosphere of the West, ranges of 100 miles have been accomplished. For longer ranges a larger mirror is required. With an 8-in. square mirror signalling has been carried on in Arizona between stations 186 miles apart. Practically, signals may be exchanged between any two points which are inter-visible, regardless of their distance apart. Intervisibility will depend on their distance

apart, their height, and the height of the intervening ground. The curvature of the earth is the important controlling factor, although signals may be exchanged between points when the right line joining them passes through the intervening ground. On account of refraction of the beam of light its trajectory is an upward curve that passes above the right line joining the two points. (For a discussion of the mathematical determination of the intervisibility of any two points, see "Manual of Visual Signaling," United States Signal Corps, pp. 83-88.)

In actual practice, however, it is seldom necessary to operate over ranges of greater than 30 to 40 miles and at these distances any of the types of heliograph employed can be depended upon to give satisfactory service.

Speed is entirely dependent upon the skill of the operators. It is comparatively easy to attain the ability to send and receive at a slow rate but speed comes only with training and practice. Twelve words per minute may be sent by skilled operators. In forest-protection work, four to six words per minute may generally be depended upon.

### Section 101—Types of Heliograph

Although all heliographs operate on the same general principles, there are important differences in the manner in which they cause the revelation and obscuration of the flash. Among those which operate by the moving flash method the type employed in the British Army is most commonly seen in Canada.

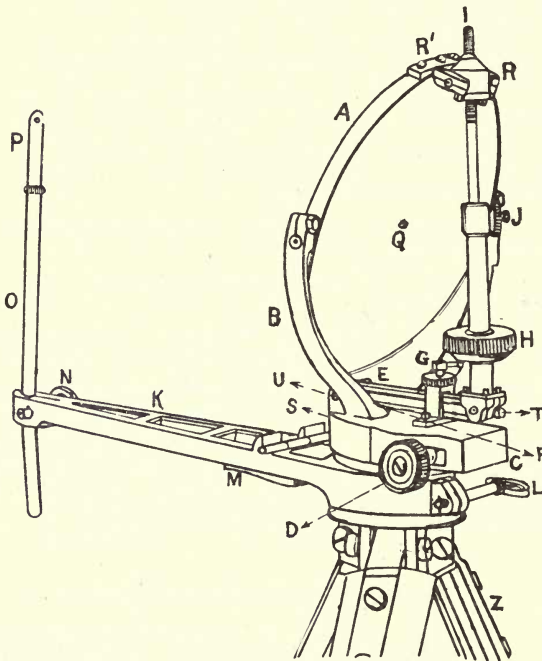

HELIOGRAPH WITH SIGHTING VANE.

Fig. 98 British Army type of heliograph, one-mirror

#### 1—BRITISH ARMY TYPE

The British Army heliograph consists essentially of a circular mirror mounted on a horizontal axis on which it is free to move. By means of an attached finger key, this mirror may be tipped so as to throw its flash on the distant station when properly adjusted. Between each revelation of the flash, the light is thrown below

or on the near side of the distant station and is not visible therefrom. This mirror is mounted directly over the head of the tripod on which the instrument is supported when in use, and various parts required for its proper alignment, adjustment, and operation are provided. For use when the sun is behind the operator, a second mirror is employed. The details of this instrument may be seen in Figs. 98 and 99, wherein it is shown as employed with one and with two mirrors.

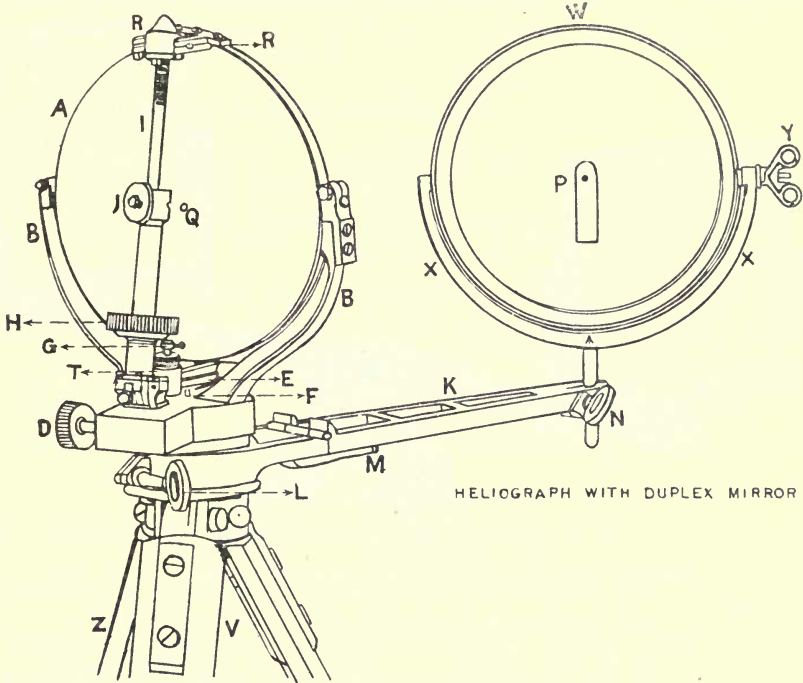

Fig. 99 British Army type of heliograph, two-mirror

List of Parts, Figs. 98 and 99: A, signalling mirror in metal frame; B, U arms for ditto; C, tangent box with lid below; D, tangent screw head; E, key; F, key spring; G, capstan screw; H, collar; I, vertical rod in vertical socket; J, clamping screw for ditto; K, jointed arm; L, clamping screw for ditto; M, gun clip; N, clamping screw at end of arm; O, sighting rod; P, sighting vane and mark; Q, unsilvered spot; R, German silver ball attached to claw R'; S, base plate; T, key bridge; U, key bearing; V, anchoring hook; W, duplex mirror; X, U arms for ditto; Y, butterfly or pivoting screw; Z, tripod.

This type of instrument has the following advantages:—

- (1) The sending key is also one of the adjusting screws and the operator can therefore have both hands on the adjusting screws even while sending.
- (2) Only one tripod is required and no screen is necessary.
- (3) The instrument is manufactured in Canada and more readily procurable than other types.
- (4) Operators skilled in the use of this type may be secured in Canada. Other types are practically unknown.

There are some disadvantages, however, as compared to other types, several of which are particularly objectionable for the uses to which the heliograph is mostly put in forest protection. These will be referred to in considering the advantages of the several other types available.

#### 2—AMERICAN ARMY TYPE

The heliograph adopted by the United States Army Signal Corps, which is the type that has been most extensively employed to date in forest-protection communi-

cation, operates on the fixed-flash system. In this system the revelation and obscuration of the flash is accomplished not by the motion of the mirror itself but by means of a separate screen placed between the mirror and the distant station in such a way as to entirely cut off the light when closed but permit it to pass freely when opened. Two tripods are required, one to carry the screen and the other the heliograph proper. The latter consists of two square plane mirrors, each  $4\frac{1}{2}$  in. to a side, and a mirror bar on which these are mounted when in use. As the mirrors when

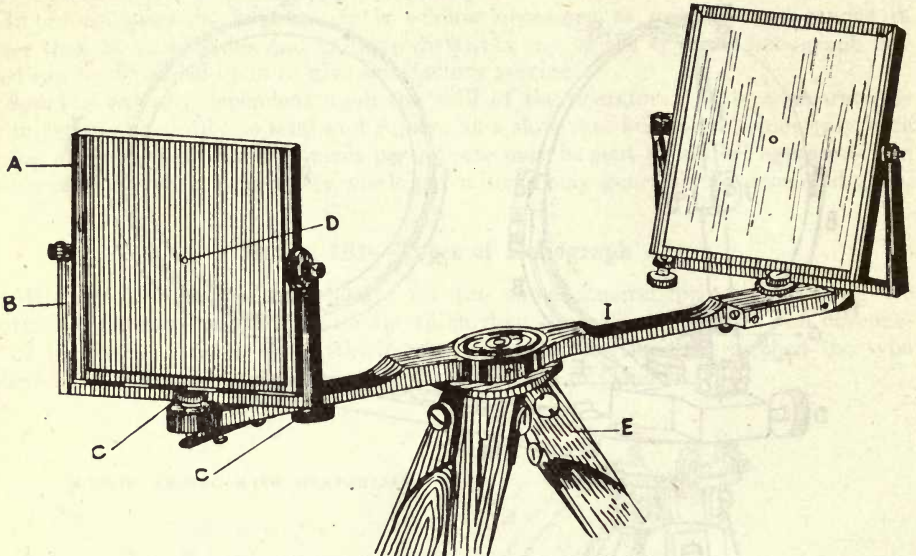

Fig. 100 American Army type of heliograph, one-mirror

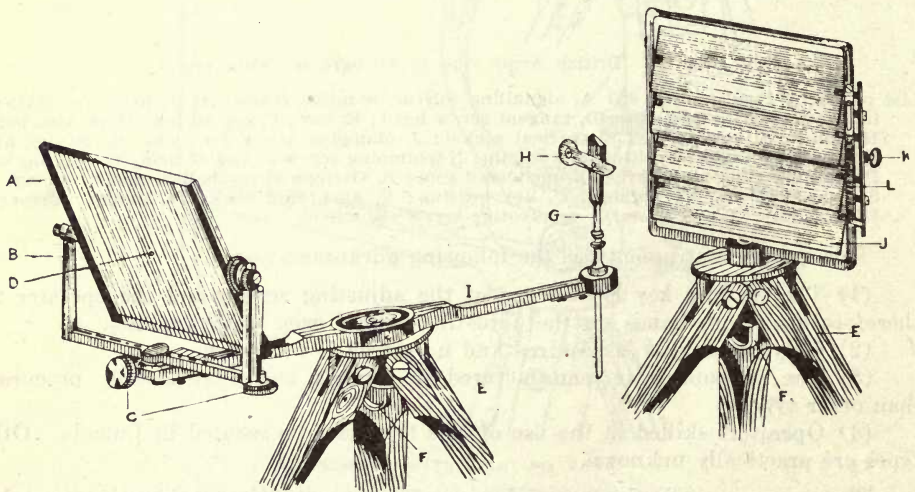

Fig. 101 American Army type of heliograph, two-mirror

A, square mirror; B, mirror yoke; C, mirror adjusting screw; D, unsilvered spot; E, tripod; F, hook for weight; G, sighting-rod; H, sighting-rod vane; I, mirror bar; J, screen; K, screen key; L, screen spring

once set and aligned do not need to be moved except to adjust them to follow the motion of the sun, the auxiliary parts are very simple, consisting merely of two



tangent screws by which each mirror may be turned on its horizontal and vertical axes. The details of this type are shown in Figs. 100 and 101 as used both with one mirror and with two.

The screen shown in Fig. 100 is  $6\frac{1}{2}$  in. square and is operated by a downward push on the key causing the thin vanes of which it is made to align themselves with their edges across the path of the beam of light, thus permitting it to pass through to the distant station. Once the flash is aligned with this type of instrument it remains fixed and all movements are confined to the screen by which the dots and dashes of the code letters are formed.

The advantages of this type of instrument are as follows:—

(1) It is very simple in design with few small parts and none that are subject to much wear in operation.

(2) The square mirror has a greater area, for practically the same packing space, than a round mirror of the same diameter.

(3) The movements in operation being confined to the screen, and there being no motion to the mirrors, make it much less likely that the latter will be thereby thrown out of adjustment.

(4) Vibration caused by high winds has less effect on the fixed flash as seen from the distant station than on the moving flash.

(5) There is no possibility of a double revelation of the flash caused by being focused too high, as there is with the moving flash.

(6) The "shadow spot" by which the adjustment of the mirror is regulated remains continuously on the guide disk and not intermittently as with the moving-flash type.

### 3—FOREST SERVICE TYPE

There has recently been invented by D. P. Godwin of the United States Forest Service, a type of fixed-flash heliograph which is to a certain degree a compromise between the British and American types of instruments and which promises to supersede the army types for many purposes in forest protection. This type, while retaining the screen and operating by the fixed-flash method, dispenses with the extra tripod by placing the screen on the tripod carrying the mirror and directly over its head where the operation of opening and closing the screen will be least likely to cause serious vibration of the mirror. Further, the construction throughout is designed to ensure the least practicable weight and bulk and the utmost simplicity of parts. As it weighs only  $4\frac{1}{2}$  pounds complete and has about the bulk of a common post-card size pocket kodak with tripod, it is a thoroughly practical patrol device and much superior for this purpose to the other forms. In all essential respects, however, this instrument is similar to the American Army type. Its general appearance is shown in Figs. 102 and 103.

### Section 102—Heliographs at Lookout Stations

Extreme light weight is not a feature of much importance for lookout or other permanent, or even semi-permanent, stations. The large types of army heliographs weigh from 15 to 20 pounds complete, which is no bar to their successful use at stations of this character. On the other hand, for lookout service the qualities required are fairly long range, dependability, and especially rigidity when exposed to high winds. These are secured to a greater degree with the two army types than with the Forest Service instrument.

Either the British Army form or the American Army form may be used for station instruments at lookouts. The  $4\frac{1}{2}$ -inch, square mirror of the latter has almost the same reflecting area as the 5-in., round mirror and therefore the same effective range.

In considering the relative merits of the two types of instrument it will be noted that the British type has the disadvantage that the manipulation of the key is liable to throw the mirror out of alignment. This is impossible with the American type

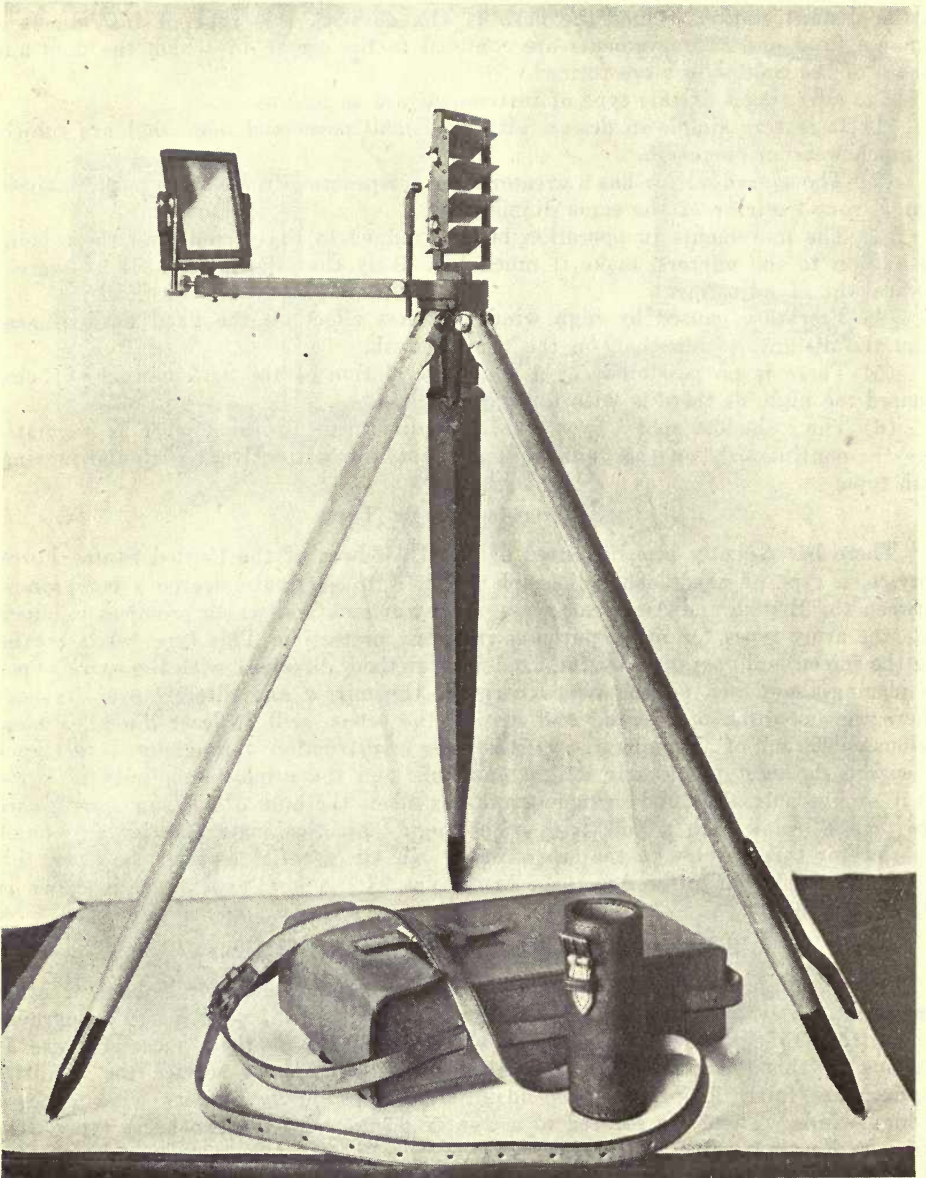

Fig. 102 Forest Service type of heliograph, one-mirror

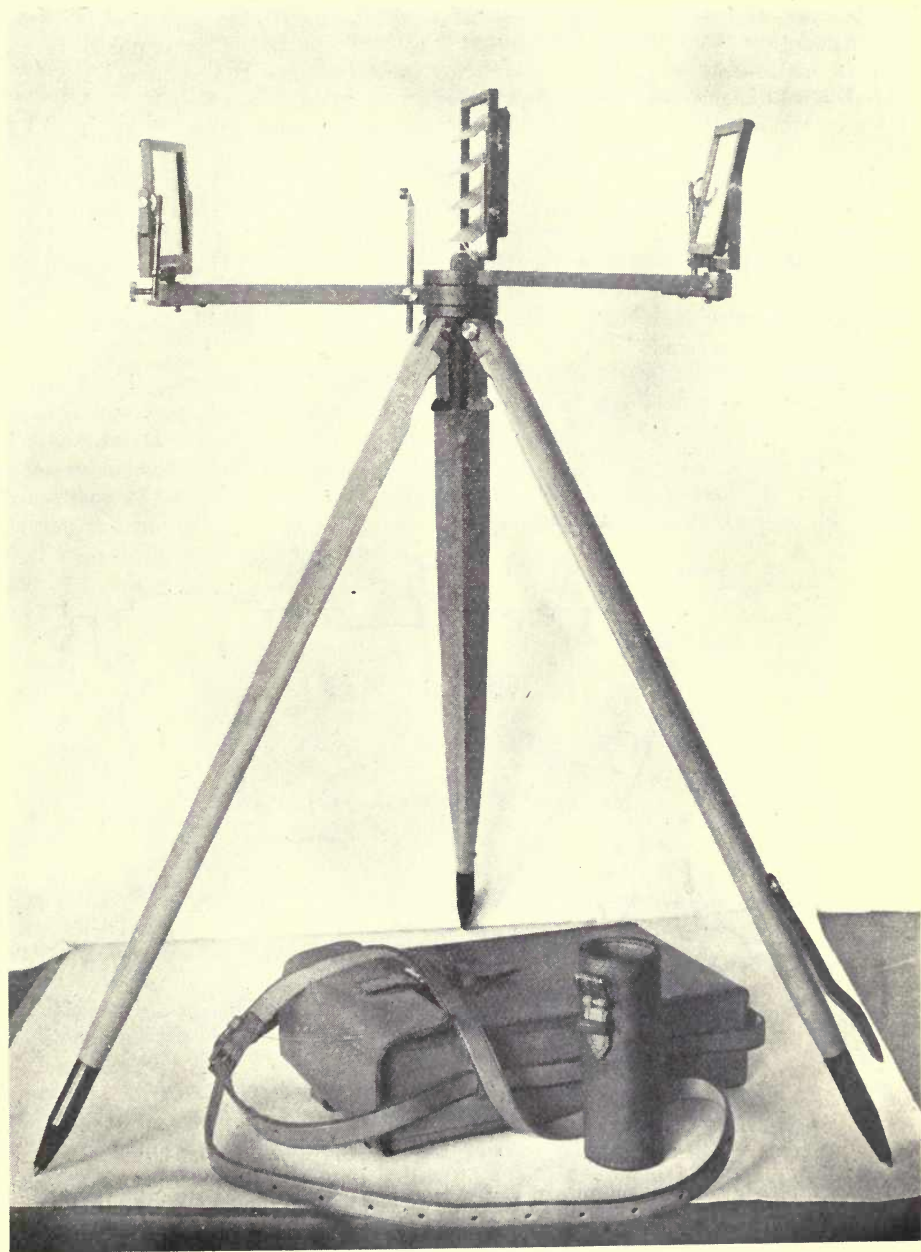

Fig. 103 Forest Service type of heliograph, two-mirror

as the screen is entirely separate. On the other hand a single operator is in a much better position to control the adjustment for sun motion during signalling when using the British type than when using the American. This is because he can have both hands on the two adjusting screws constantly, as one of them is used as the key to elevate the mirror. This is important as the adjustment for sun motion is needed at extremely short intervals and is often a serious handicap to one man when using the American Army heliograph. The fact that an extra screen and tripod is required for the American instrument is of little importance in station use and is more than offset by the disadvantage of the greater number of small parts in the British models. The latter also are more subject to difficulties in signalling caused by vibration in high winds. This is serious, because most lookout stations are located where winds of considerable violence blow more or less constantly. It is believed that for the best possible results under all conditions a combination of the British type of instrument with the American form of screen will give the greatest satisfaction. The screen should be used only when vibration or other troubles render it necessary. It is to be noted, however, that this is a rather expensive equipment and would cost about twice as much as the Forest Service instrument alone, this last being considerably the lowest-priced heliograph on the market.

Heliographs cannot be successfully employed on lookout towers. The reason is that nearly all such towers vibrate excessively both as a result of wind and from the movements of the operator on the platform. This vibration makes it impracticable to keep a heliograph in adjustment. A platform on top of a lookout cabin or ranger station if rigidly braced may be sufficiently free from vibration to be successfully occupied for heliograph communication.

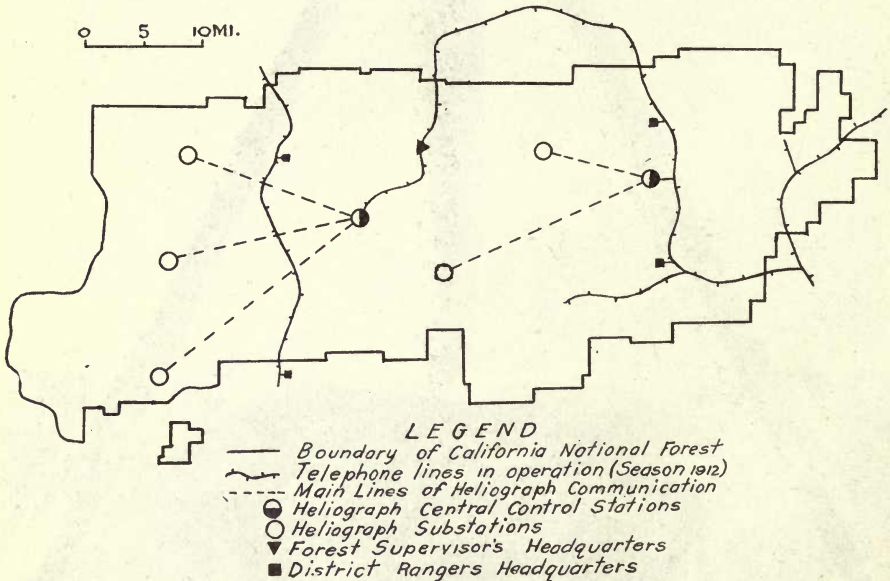

Fig. 104 Map of California National Forest, showing heliograph system.

Heliograph stations on mountain lookouts will generally be the most important in the forest, and this use of the station should always be considered when equipping a forest with a lookout fire-detection system. Direct communication between as many stations as possible should be aimed at, and in addition one or more such stations should be arranged to communicate with important headquarters on the lower levels which may be joined to the telephone system. An example of this kind is shown in Fig. 104.

## Section 103—Heliographs on Patrol Routes

The use of heliographs by patrolmen or other moving units of a forest-protection force brings up the question of light weight and ready portability, as previously mentioned. Such use is only practicable on a forest equipped with a permanent lookout system for fire detection, and then only under topographic conditions which make it readily possible for patrolmen to find points easily and quickly from which they can open communication with lookout stations. This is not often practicable in a heavily timbered region of little relief, but is easily accomplished in any rolling, hilly or mountainous country.

For patrol purposes, the Godwin or Forest Service heliograph is the only practical type. Its weight and size make it an entirely practicable equipment for any kind of patrol and its range is sufficient for most forests where it might be employed. A use for this instrument will exist wherever the standards of protection employed make it impossible to secure rapid enough communication by message carried to the nearest telephone station. Of course, the degree of development of the telephone system will exercise a very considerable influence on this time interval, but as long as it remains necessary to establish a physical connection with a telephone wire in order to use the line and as long as maintenance charges remain as they are, very large areas in all forest regions must necessarily remain without immediate telephone service. Conditions may vary all the way from a protection staff which depends entirely on the heliograph for intercommunication between all units to a staff which uses the heliograph merely as an emergency auxiliary, placing its dependence primarily on a telephone system. The difference will result from the protection standards employed, that is the maximum of average annual damage to which the protection system is designed to restrict the forest fire loss.

## CHAPTER XIX

## USE OF THE GODWIN HELIOGRAPH

## Section 104—Parts of the Instrument

## LIST OF PARTS

The complete instrument consists of a sole-leather case with shoulder-strap containing: (a) One sun mirror, (b) one station mirror, (c) one screen, (d) one sighting rod, (e) two mirror bars; the above in two padded wooden packing blocks; and (f) one tripod with leather cup for points.

The heliograph and case is  $10\frac{1}{2}$  by  $5\frac{1}{2}$  by  $2\frac{1}{2}$  in. outside dimensions and weighs 4 pounds 9 ounces. The tripod folded is 2 in. in diameter by  $23\frac{1}{2}$  in. long and weighs 7 pounds 3 ounces.

(a and b) *Mirrors.*—Two plane mirrors each  $2\frac{3}{4}$  in. square are employed. These are very carefully constructed so as to have both surfaces parallel, are backed with pure silver, and varnished. Each is mounted in a black metal frame and swings in a yoke on pivots at the sides. A slow-motion adjusting screw is provided by means of which the mirrors when set up may be rotated on the line between these pivots as an axis. This axis passes through the centre of the mirror. In the centre of each mirror there is an unsilvered spot  $\frac{1}{16}$  in. in diameter. On the lower side of the yoke there is a tapered stud which fits into a hole at the end of the mirror bar when the instrument is set up. Both mirrors are exactly alike and may be used interchangeably, except that when both are employed at one time it is necessary to paste a small white paper disk in the centre of one of the mirrors on which to hold the "shadow spot." The

mirror thus equipped is then known as the "station mirror" and reflects the light to the distant station. The other reflects the light from the sun to the station mirror and is known as the "sun mirror." All metal parts are brass or aluminium bronze and are finished in dull black.

(c) *Screen*.—The screen consists of a metal frame  $4\frac{3}{4}$  in. square. Within this frame, swung on pivots, the lines between which are horizontal, are four thin metal leaves or vanes. At one side of the screen is a movable bar connected by levers to the vanes in such a way that when it is pressed downward the vanes rotate on their horizontal axis through an angle of  $90^\circ$  and thus open the screen. On releasing the bar, a spring causes it to fly back to its original position and with it the vanes, thus closing the screen. On the bottom of the screen frame is an angle foot by which it is attached to the head of the tripod. Near the bottom of the sliding-bar is a small projecting lug with a hole in it through which is passed a string by which the screen or shutter is opened and closed while being used for signalling. An adjusting screw near the top of the retractile spring enables it to be tightened if it becomes weakened through use.

(d) *Sighting-rod*.—This is a round metal bar  $3\frac{3}{4}$  in. long, flattened and pointed at one end. To this flattened portion a small metal vane is pivoted which carries a white target at the top for use in adjusting. This sighting-rod fits in a round hole in one of the mirror bars in which it is held by a set-screw.

(e) *Mirror Bars*.—Two are required. They are similar in construction except that the one used with the sun mirror has a hole near the tripod attachment for the insertion of the sighting-bar, and a set-screw for holding it in place. This bar is also equipped with a tangent adjusting screw at the end, by means of which the mirror mounted on it may be rotated on its vertical axis. The bars are 9 in. long, rectangular in cross-section and enlarged at the end that fits on the tripod to a circle 2 in. in diameter. At the other end, both have a round, tapered hole in which the studs on the frames of the mirrors fit. A pivoted catch on the underside of each bar holds the mirrors when in place. The slow-motion adjusting screw provided on one of the bars together with the similar screw on the mirror enable the operator to rotate the sun mirror simultaneously on both its vertical and its horizontal axes. These axes intersect at the centre of the mirror at the point where the unsilvered spot is located, and by means of the two adjusting screws the mirrors may be made to follow the sun while the instrument is in use.

(f) *Tripod*.—A light but strong tripod with a flat, circular, brass head-plate is provided. The cross-section of the legs is one-third of a circle, so that when folded the tripod forms a neat cylindrical package. In the centre of the brass head is a round hole in which is fitted a bolt having a three-wing nut at the lower end. The upper end is provided with a lug. This lug fits in holes in the mirror bars and over the angle foot of the screen, and by tightening the winged nut the various parts may be attached firmly to the head of the tripod. A cylindrical sole-leather cup with strap and buckle fits over the points of the tripod legs when folded for transportation.

## Section 105—Using the Godwin Heliograph

### 1—SETTING UP

Set the tripod firmly on the ground with one leg toward the distant station and the metal head as level as possible. A station heliograph on hard ground, rock, or a wooden platform may have the legs set in pails, boxes, etc. filled with earth. To prevent vibration in heavy wind, suspend a bag filled with sand or earth beneath the tripod so that it touches the ground just enough to keep it from swaying (Fig. 105). In the Godwin type this cannot be done until setting up is completed as the weight must be attached to the tripod head-bolt. Other types are provided with special anchoring hooks for this purpose.

The position of the sun must be the guide for determining whether one or two mirrors should be used. When the sun is in front of the operator (that is, in front of a plane through his position at right angles to the line joining the stations) the sun mirror only is required; with the sun in the rear of this plane both mirrors should be used. When one mirror is used the rays of the sun are reflected from the sun mirror direct to the distant station; with two mirrors, the rays are reflected from the sun mirror to the station mirror, thence to the distant observer. Care should be taken to note in which direction the sun is moving so that it may not be necessary to change from one mirror to two while signalling.

## 2—EMPLOYMENT WITH ONE MIRROR

Run the winged nut down to the lower end of the threaded shank of the head-bolt. Push the bolt up through the tripod head and slip over the lug the main mirror bar (the one with hole for sighting-bar), taking care that the side of the bar bearing the maker's name is up and that the bar points directly away from the distant station and back toward the operator. Turn the lug on the head-bolt at right angles to the long axis of the mirror bar and slip under it the angle foot of the screen, so that as



Fig. 105 Forest ranger sending message by heliograph

you stand facing the instrument and the distant station the spring of the shutter is on the right. To accomplish this, the angle foot of the screen must, of course, be inserted from the side toward the distant station. The screen should be at right angles to the mirror bar. Clamp both bar and screen firmly in place by tightening up the winged nut.

Place the sighting-rod in the hole in the mirror bar and hold it temporarily in place with the set-screw provided for that purpose. The pivoted vane bearing the white target should face toward the operator. Turn this vane down to the left. Pull down the shutter key and wedge the shutter open by some simple catch. A weight suspended on the end of a string tied to the pin on the sliding-bar of the screen will do.

Place one of the mirrors in the hole at the end of the bar and clamp in place by the catch underneath the bar for that purpose. Turn the mirror so that it stands in a plane parallel to the plane of the screen at right angles to the mirror bar.

Now sight through the hole in the centre of the mirror and over the point of the sighting-bar in the same manner that the peep sight and the front sight of a rifle are used, aiming at the distant station. These three points must be brought accurately into line by adjusting the position of the sighting-bar and the mirror. To do this loosen the winged nut on the head-bolt slightly and turn the mirror bar to the left or right. At the same time raise or lower the point of the sighting-bar. It requires some practice to perform this operation quickly. Care must be taken not to loosen the head-bolt too much and disturb the attachment of the mirror bar and screen.

When these three points have been brought into perfect alignment, clamp head-bolt and sighting-bar firmly, close the screen, turn the white target of the sighting-bar to a vertical position and then, by means of the tangent adjusting screws on the mirror, turn it on both its vertical and its horizontal axes until the small shadow spot cast by the unsilvered spot in the mirror falls exactly in the centre of the white target. A sheet of paper, held so as to intercept the reflected beam of light from the mirror about 6 in. in front of it, will assist in locating the shadow spot and in bringing it on to the target in this operation. The heliograph is now aligned and adjusted for signalling to the distant station but it is extremely important to note that the shadow spot must not be allowed to move off the centre of the target on the sighting-rod during operation.

### 3—EMPLOYMENT WITH TWO MIRRORS

When the sun is in the rear of the operator the second mirror and supplemental mirror bar must be employed. Place the main mirror bar on the tripod head first, and follow it with the supplemental mirror bar and the screen. Turn the supplemental bar into the position occupied by the main bar when using one mirror only, and place the screen at right angles to its long axis. In placing the screen, it should be put on in the reverse position with the sliding-bar and key on the left side, as the operator stands facing the distant station. Turn the main mirror far out in front of the screen (toward the distant station) and slightly to one side. In this position the two bars should form a wide obtuse angle. Place the two mirrors in position at the ends of the bars, and clamp. The purpose of the front, or sun mirror is to reflect the sunlight on to the station mirror from which it is reflected to the distant station. The front mirror is preferably swung out to the left and the operator takes up a position behind it where he is in easy reach of the adjusting screws and can readily watch the shadow spot on the white disk in the centre of the station mirror. When operating from this position, however, care must be taken not to permit the hand to cut off the light reflected from the sun mirror to the station mirror. A string or wire about 3 in. long with a  $\frac{3}{4}$ -in. ring on the end, suspended from the lug on the sliding-bar of the screen will be found to be the best equipment for operating a screen of this type.

Alignment with two mirrors is accomplished as follows: After setting up and placing mirrors as indicated with the station mirror approximately facing the distant station, the sun mirror facing the sun, and the screen wedged open, stoop down with the head near and in the rear of the station mirror and look over its top into the sun mirror. Turn the sun mirror by means of its adjusting screws until the whole of the station mirror is seen reflected in the sun mirror and the unsilvered spot and reflection of the paper disk accurately cover each other. Still looking into the sun mirror, adjust the station mirror until the reflection of the distant station is brought exactly in line



with the top of the reflection of the disk and the top of the unsilvered spot of the sun mirror; after this the station mirror must not be touched. Now step behind the sun mirror and adjust it by means of the tangent screws so that the shadow spot falls on the centre of the paper disk on the station mirror. The flash will then be visible at the distant station.

An alternate method of alignment is as follows: Stoop down behind the sun mirror and while looking through the small hole in this mirror turn the station mirror on its vertical and horizontal axes until the paper disk on the station mirror accurately covers the distant station. Standing behind the sun mirror, turn it on its vertical and horizontal axes by means of the tangent adjusting screws until the shadow spot falls on the centre of the paper disk on the station mirror.

In operating the heliograph from a position behind the sun mirror the operator is not as favourably placed for watching the distant station as when standing behind the station mirror, but he is able to maintain his adjustment more perfectly and conveniently and on this account will generally secure more satisfactory results.

## CHAPTER XX

### SIGNALLING WITH THE HELIOGRAPH

#### Section 106—Selecting a Station

Permanent stations will nearly always be selected with objects in view that take precedence over the requirements of the signalling apparatus. Such stations may, however, be improved artificially, if not entirely suitable.

Semi-permanent and temporary stations are occupied for signalling purposes primarily and should be selected with this end in view. Stations should be selected so that they are in full view of the station or stations it is desired to communicate with. They should be located at as great an altitude as possible, especially when there is difficulty about haze, smoke, dust, or undulations of the atmosphere noticeable on hot summer days. A dark background is preferable for heliograph stations, so that it is not always desirable to locate on the top of a conical peak which would probably ensure a sky background. Select a station on the slope. Heliograph stations should be protected from the wind. This may be accomplished by setting up in the lee of a clump of trees, a rock, or a building, but care must be taken to ensure that by so doing the shadow will not fall on the instrument at any period during the day.

#### Section 107—Position of Operator

In operating the Godwin heliograph the operator stands directly behind the sun mirror with the right hand holding the string by which the screen is opened and the left on the tangent screws of the mirror. Both screws must be manipulated with one hand and the rate and direction of movement depends upon the locality and the time of day. By means of them the mirror must be made to follow the sun continuously; this being accomplished by keeping the shadow spot on the centre of the target of the sighting-rod or disk of the station mirror, as previously explained.

In using the British Army type of heliograph the position of the operator is the same, but with these instruments the key held in the right hand is also one of the adjusting screws. The left hand holds the other. The operator is thus able to use both hands for adjusting while signalling. The shadow spot, however, falls on the centre of the target only momentarily while a flash is directed at the distant station, and not continuously as in the Godwin type.

In using the American Army type, the screen must sometimes be placed so far from the mirror that it is difficult to reach both screen and adjusting screws at the

same time. This must be carefully guarded against in setting up the instrument, as otherwise it becomes nearly impossible for one man to maintain proper adjustment during operation.

When receiving a message the operator must be careful to remain in position at his instrument so that he may interrupt the sending station if necessary. He must also keep his heliograph in adjustment constantly both when sending and receiving.

### Section 108—Maintenance of Adjustment

The importance of careful attention to adjustment arises from the fact that the light from a heliograph mirror is projected in the form of a cone, the lateral range of which theoretically bears the same proportion to the distance between stations as the diameter of the sun bears to its distance from the earth; that is approximately 1:107. Thus with the mirror aligned correctly on the distant station, the light will be visible on either side of the station up to one-half of the distance between stations divided by 107; for example, if the stations are six miles apart, the flash theoretically will be visible about 50 yards on either side of the station. In practice, owing to imperfections of mirrors, the lateral range is somewhat greater and the intensity of the light is less at the outer edge of the cone than at its axis. This fact together with the very small lateral distance in which the light is visible, makes it essential that for the best results the alignment be made carefully so as to have the axis of the cone of light strike the distant station, and the adjustment maintained constantly. Perfect adjustment is secured only by keeping the shadow spot uninterruptedly in the centre of the paper disk, and, as this spot continually changes position with the apparent movement of the sun, when two men are at a station, one should be in constant attendance on the tangent adjusting screws. When working alone, operators must watch their adjustment very closely to ensure that the light reaches the distant station. A little practice will soon show how far the spot may move from the exact centre of the paper disk before the flash becomes invisible at the other station. Extra care bestowed upon preliminary adjustment is repaid by increased brilliancy of flash. Remember, the distant observer is unquestionably the better judge as to the character of the flash received; and if, therefore, adjustment is called for when the shadow spot is at the centre of the disk, the alignment is probably at fault and should be looked after at once.

### Section 109—Opening Communication

In forest protection the locations of all permanent heliograph stations will be known to all members of the force. To attract the attention of a station once the heliograph is aligned on it, send a succession of flashes until answered. The heliograph flash is strikingly noticeable, but attempts to attract attention, to be successful, must be persistent. They should never be abandoned until every device has been exhausted. When acknowledged, each station will then turn on a steady flash and adjust. When the adjustment is satisfactory to the station called, it will cut off its flash and the calling station will proceed with its message.

The exact location of semi-permanent stations, especially when placed at a low level, is sometimes difficult. The compass bearings of all such stations from the heliograph stand should always be taken by each permanent station operator. A still better method is to set two stakes about twenty yards apart with the tops directly in line with the distant station, marking on the far stake the name of the station that it indicates. Where stations are so located that smoke from forest fires is likely to obscure them, a whole series of such guide-line posts should be permanently erected showing the line to each station within the range of communication. With such stakes accurately aligned it is then possible to call any station within range even though the station may be temporarily obscured by smoke. To call under these circumstances, loosen the catch on the underside of the mirror bar and rotate one of the mirrors by hand until the flash is

seen to pass directly across the tops of the two range stakes. Move slowly back and forth in the azimuth in which the station is known to lie until the call is acknowledged. Then adjust on the flash from the distant station and proceed with the message.

### Section 110—Working at Short Ranges

At ranges up to about 10 miles, it will be found that the flash from the heliograph is extremely tiring to the eyes. For short ranges with 4-in. or larger mirrors, cover a part of the station mirror with a pasteboard disk having a hole in the centre 2-in. in diameter, or wear smoked glasses. Lookout men will generally be equipped with coloured glasses and should wear them when reading heliograph signals. The heliograph is more rapid and, at any but very short ranges, is more easily read than the flag, but it has various disadvantages that will not ordinarily cause it to be preferred to the flag at ranges under five miles unless it is necessary to signal through haze or smoke. For very short ranges, the flag described in chapter XXII will be found preferable to the heliograph and more generally available.

### Section 111—Working through Haze and Smoke

A remarkable and extremely valuable property of the heliograph flash in forest protection is its ability to penetrate smoke. This increases with increase in size of the mirror. With the standard American Army 4½-in. mirror the author has read signals with the naked eye at a distance of 15 miles, when even the outlines of the mountain peak on which the sending heliograph was located could not be distinguished because of smoke from forest fires. At the same time this station was in continuous communication with another, 30 miles distant, although neither was for days able to see the mountain on which the other was located. This property, of course, has its limitations and very dense smoke will make heliograph communication impossible but probably not till long after location of fires by lookout men has become fully as impracticable.

### Section 112—Heliograph Codes

Four different codes have been used for heliograph signalling. These are: (1) American Morse Code, (2) International Morse Code, (3) Myer Code, (4) Alphabetical Square Code.

#### 1—AMERICAN MORSE CODE

This code is only used for telegraphic communication in the United States and Canada. It is distinguished from the International Morse code by the "space" or "pause" used between the elements of certain letters. It is not now used for visual signalling although it may be so employed if desired, but has no advantages over other codes.

#### 2—INTERNATIONAL MORSE CODE

This is the telegraph code used generally throughout the world except in the United States and Canadian telegraph services. It is also called the Continental code and is the code most commonly employed for heliograph signals. All letters consist of combinations of dots and dashes. With the heliograph these are made by short and long flashes.

The dash is represented by a flash of about two seconds' duration.

The dot is represented by a flash one-third as long.

The interval between flashes should be one-half second.

The interval between letters, one second.

The interval between words, two seconds.

INTERNATIONAL MORSE ALPHABET

A	— — — — —	N	— — — — —
B	— — — — —	O	— — — — —
C	— — — — —	P	— — — — —
D	— — — — —	Q	— — — — —
E	— — — — —	R	— — — — —
F	— — — — —	S	— — — — —
G	— — — — —	T	— — — — —
H	— — — — —	U	— — — — —
I	— — — — —	V	— — — — —
J	— — — — —	W	— — — — —
K	— — — — —	X	— — — — —
L	— — — — —	Y	— — — — —
M	— — — — —	Z	— — — — —

NUMERALS

1	— — — — —	6	— — — — —
2	— — — — —	7	— — — — —
3	— — — — —	8	— — — — —
4	— — — — —	9	— — — — —
5	— — — — —	0	— — — — —

SHORT NUMERALS

1	— — — — —	6	— — — — —
2	— — — — —	7	— — — — —
3	— — — — —	8	— — — — —
4	— — — — —	9	— — — — —
5	— — — — —	0	— — — — —

The short numerals are only used in telegraphy in the repetition of figures.

PUNCTUATION

Period	— — — — —	Exclamation	— — — — —
Comma	— — — — —	Apostrophe	— — — — —
Interrogation	— — — — —	Semicolon	— — — — —
Hyphen or dash	— — — — —	Colon	— — — — —
Parenthesis	— — — — —	Cross	— — — — —
Quotation mark	— — — — —		

CONVENTIONAL SIGNALS

End of word . . . . .	Interval (2 seconds).
End of sentence . . . . .	Double interval (period).
End of message . . . . .	Triple interval (cross).
Acknowledgment, or I understand	R
Error . . . . .	— — — — —
Repeat after (word) . . . . .	Interrogatory. (word).
Send faster . . . . .	Q R Q
Send slower . . . . .	Q R S
Cease sending . . . . .	Q R T
Wait a moment . . . . .	— — — — —
Move to your right . . . . .	M R
Move to your left . . . . .	M L
Move up . . . . .	M U
Move down . . . . .	M D

It will often be found very advantageous to substitute for the conventional signals given above, the following:—

- End of word. . . . . 1 extra long flash (about three times the length of a dash).
- End of sentence. . . . . 2 extra long flashes.
- End of message . . . . . 3 extra long flashes.

Although this slows up the transmission it is a great help to poorly trained operators, and is particularly valuable when sending code messages where it is impossible to make out the proper spacing from the context.

This code is used for signalling with the heliograph by the British and Canadian military forces and will probably be the one best adapted for use in Canada in forest-protection communication. It is adapted not only to visual but also to electric telegraphic signalling and radio work.

3—MYER CODE

This code was formerly used by the United States Army for visual signalling and is still employed in certain districts by the United States Forest Service. In this code there are three elements, generally designated, 1, 2, and 3. All letters are made up of combinations of 1 and 2; 1 being a short flash; 2, two short flashes in quick succession. 3 is a long flash, like a dash of the International Morse code, and is used to indicate certain pauses and in conventional signals. This code has certain advantages for heliograph work, although it has now been pretty generally abandoned in favour of the more generally useful International Morse code.

MYER CODE ALPHABET

A . . . . .	22	O . . . . .	21
B . . . . .	2112	P . . . . .	1212
C . . . . .	121	Q . . . . .	1211
D . . . . .	222	R . . . . .	211
E . . . . .	12	S . . . . .	212
F . . . . .	2221	T . . . . .	2
G . . . . .	2211	U . . . . .	112
H . . . . .	122	V . . . . .	1222
I . . . . .	1	W . . . . .	1121
J . . . . .	1122	X . . . . .	2122
K . . . . .	2121	Y . . . . .	111
L . . . . .	221	Z . . . . .	2222
M . . . . .	1221	Question . . . . .	1112
N . . . . .	11		

NUMERALS

1 . . . . .	1111	6 . . . . .	2211
2 . . . . .	2222	7 . . . . .	1222
3 . . . . .	1112	8 . . . . .	2111
4 . . . . .	2221	9 . . . . .	1221
5 . . . . .	1122	0 . . . . .	2112

ABBREVIATIONS

A . . . . .	After	T . . . . .	The
B . . . . .	Before	U . . . . .	You
C . . . . .	Can	Ur . . . . .	Your
H . . . . .	Have	W . . . . .	Word
N . . . . .	Not	Wi . . . . .	With
R . . . . .	Are	Y . . . . .	Yes

CONVENTIONAL SIGNALS

- |                            |  |
|----------------------------|--|
| End of word. .3.           | Repeat last word. .121 121 33.         |
| End of a sentence. .33.    | Repeat last message. .121 121 121 333. |
| End of a message. .333.    | Wait a moment. .1111 3.                |
| Acknowledgment,            | Signal faster. .2212 3.                |
| or I understand. .22 22 3. | Cease signalling. .22 22 22 333.       |

4—ALPHABETICAL SQUARE CODE

This code is constructed according to a very simple rule which may be easily remembered, so that it is possible to improvise the entire code at any time. Aside from this it would not appear to have any marked advantage over other codes. The code is made by arranging the letters of the alphabet in five vertical columns of five letters each, K being omitted and C substituted for K wherever it occurs. Each letter is then represented by a number of two places, the first figure being the number of the column in which the letter occurs, counting from the left toward the right, and the second its place in this column counting from the top downward. This arrangement is as follows:—

	1	2	3	4	5
1	a	f	l	q	v
2	b	g	m	r	w
3	c	h	n	s	x
4	d	i	o	t	y
5	e	j	p	u	z

The alphabet follows:—

- |       |       |       |       |       |
|-------|-------|-------|-------|-------|
| a=1-1 | f=2-1 | l=3-1 | q=4-1 | v=5-1 |
| b=1-2 | g=2-2 | m=3-2 | r=4-2 | w=5-2 |
| c=1-3 | h=2-3 | n=3-3 | s=4-3 | x=5-3 |
| d=1-4 | i=2-4 | o=3-4 | t=4-4 | y=5-4 |
| e=1-5 | j=2-5 | p=3-5 | u=4-5 | z=5-5 |

Each letter is made by sending short flashes only, to the number of each of the two elements of the letter, with a short pause amounting to one beat of time between these elements. A pause of two beats of time is allowed between the letters, and between words there is either a pause of three beats or the long flash may be used, as with the Myer code. The latter is to be preferred with poorly trained operators. Thus the letter M (3-2) would be represented by three short flashes, a pause of one beat of time, and then two short flashes. Experiment has shown that a message may

be sent with this code quite as rapidly as with the Myer code and only a little less rapidly than with the International Morse code. The fact that each letter consists of only two symbols, and that only dots are sent and no dashes, makes it an easier code to send intelligibly and to read. The further fact that it is made according to a simple rule as already explained, is an advantage in forest-protection work, where the use of the heliograph is confined to a limited portion of the year and where operators will generally not be able to keep in practice. In the district where this code is employed for forest-protection communication the following numerals and conventional signals have been adopted:—

NUMERALS

B . . . . .	1	G . . . . .	6
C . . . . .	2	H . . . . .	7
D . . . . .	3	I . . . . .	8
E . . . . .	4	J . . . . .	9
F . . . . .	5	M . . . . .	0

CONVENTIONAL SIGNALS

End of word . . . . .	Interval (2 seconds)
End of sentence or message..	1-6      Wait a moment. . . . . 6-1
I understand. . . . .	2-6      Signal faster . . . . . 6-2
Repeat last word . . . . .	3-6      Cease signalling . . . . . 6-3
Repeat last message . . . . .	4-6      I wish to use message code . . 6-4

**Section 113—Instructions to Operators**

In sending with the heliograph it is of the utmost importance that uniformity in mechanical movements of the screen be cultivated, as lack of rhythm in the signals of the sender entails unnecessary and vexatious concentration of attention on the part of the receiver.

The first position is to turn a steady flash on the receiving station. The signals are made by long and short flashes. Use a short flash for dot and a long steady flash for a dash. The elements of a letter should be slightly longer than in sound signals.

*To call a station.*—Send a rapid succession of short flashes until acknowledged. Each station will then turn on a steady flash and adjust. When the adjustment is satisfactory to the called station it will cut off its flash and the calling station will proceed with its message.

*Adjustment.*—If the receiver sees that the sender's mirror needs adjustment, he will turn on a steady flash until answered by a steady flash. When the adjustment is satisfactory the receiver will cut off his flash and the sender will resume his message.

*To break or stop the signals from the sending station.*—Make a rapid succession of short flashes without pause until the sender stops sending.

*To start the sending station after breaking.*—Turn on a long flash and he will commence at the beginning of last word.

*To acknowledge receipt of a message.*—Signal - - - - followed by the name of the receiver.

If the sender discovers that he has made an error he should make a rapid succession of short flashes, after which he begins with the word in which the error occurred.

To lessen liability of error, numerals which occur in the body of a message should be spelled out in full.

A record of the time of receipt and transmission of every official message should be kept.

In receiving messages nothing should be taken for granted and nothing considered as seen until it has been positively and clearly in view. Do not anticipate what will follow from signals already given. Watch the communicating station until the last signals are made and be very certain that the signal for the end of a message has been given.

Attempts to attract the attention of a station to be successful must be persistent. They should never be abandoned until every device has been exhausted.

### Section 114—Care of Instruments

(1) When riding always carry the heliograph slung across the shoulders and not attached to the saddle. On a pack-horse it should be rolled in the bedding.

(2) Never leave the heliograph on its stand when the work with it is finished. Dismount and replace in its case.

(3) Avoid holding the instrument by the U arms or mirror frame.

(4) If the heliograph gets wet, rub the metal portions over with an oily rag before putting it away or at the first opportunity.

(5) Always keep the heliograph clean and free from rust and dust. Grit and dust in the tangent screws or sockets of the mirror bars will soon destroy the best instrument.

(6) Occasionally oil the working parts (screen, sliding-bar, vanes, tangent screws, bearings, etc.); but never leave superfluous oil on any part, as it collects dust. Never allow oil to drop on the mirror.

(7) Make adjustments of the bearings, etc., only when necessary. Be careful not to damage or burr the heads of screws, and see that the threads are not crossed or otherwise mutilated.

(8) Before commencing any minor repairs, consider by which means the fewest screws and parts need be removed. Avoid stripping the heliograph on ground where the parts would be easily lost, such as in long grass, etc. If possible spread a blanket or pack cover on which to work.

### Section 115—Training Operators

The following, taken from "Systematic Fire Protection in the California Forests", corresponds with the author's experience, and is quoted as a suggestion to those who may undertake to employ the heliograph in forest protection:—

"It has been proven by experience that the average mountain man selected for lookout service is quite capable of learning and becoming proficient in the use of the heliograph. The first step in installing this system on a forest should be to secure the services of an experienced instructor to train the new men.

"In heliograph work, practice is absolutely essential to fast and intelligible signalling. A common fault is the failure to keep the mirror in perfect adjustment while operating. This fault is extremely annoying to the receiving station and must be eliminated. The actual spelling out of words is not the difficult part; the trouble comes in at the ends of words, ends of sentences, ends of messages, getting started, failure to observe the conventional methods of calling, breaking signals, starting again, acknowledgment of messages, etc. It is only through constant drilling, as in the case of telegraph operating, that the heliograph man learns these tricks of the trade.

"The average speed attained by the best Forest Service operators has been found to be about four words a minute. The average fire message need not exceed twenty words, so it will be seen that after the discovery of a fire an expert heliograph man can get the news to his receiving station in five minutes. Twice this length of time should be a safe figure for an ordinary operator."



Heliographs have only once been employed in forest protection in Canada. There is no reason, however, why they would not be extremely useful. Suitable atmospheric conditions prevail throughout the western forest regions, especially in Alberta and the interior of British Columbia and during most of the summer throughout the east and north.

One ameliorating circumstance in connection with the impossibility of using the heliograph except in full sunlight lies in the fact that with rain or overcast sky the need for using it in connection with forest protection is likely to be very much reduced. Successful utilization of this instrument, of course, requires the employment of interested and intelligent men and a higher degree of organization and discipline in the protection staff than has heretofore been thought necessary.

The learning of the alphabet can be taken up indoors by using an inexpensive telegraph key and sounder installed with a telephone dry cell. Practice should be continued until the letters, numerals, and conventional signals are thoroughly mastered.

The operators should then be practised on the heliograph itself and taught to set up quickly and align accurately. Men can practise singly in maintaining alignment and also in cultivating rhythmic sending by directing the beam toward an ordinary mirror set up at a distance of about 100 ft. and placed so that the flash is reflected back to the sender.

When the alphabet has been thoroughly learned and a good sending-speed developed, a practice range equipped with telephones should be installed. The distance between said stations may be as long as conditions warrant but should, if possible, be at least half a mile. If an existing telephone line cannot be tapped, a temporary line may be built with emergency wire if available. On this range with two instruments a number of men may be taught to receive messages, to send messages, and, especially, they may be given practice in the various "tricks" of sending and receiving that generally prove most difficult for beginners. The telephone serves to keep the instructor in touch with both sets of men and enables him to correct mistakes of sending with the least difficulty.

For use at night or on dull days when the heliograph cannot be operated a couple of signal-lanterns will be found highly convenient for instructional and practice purposes.

### Section 116—Heliographing by Moonlight and Artificial Light

The heliograph has been used to send messages by moonlight but the range is extremely limited. It cannot be depended upon at any ordinary forest range.

Artificial light may also be employed, the range depending on the strength of the light. Only short ranges as a rule may be attained. When using an artificial light with the fixed-flash heliographs it will generally be found more satisfactory to employ the screen only, rather than attempt to reflect the light from the mirror.

# CHAPTER XXI

## NIGHT SIGNALLING

### Section 117—Signalling-lanterns

Although the variety of lanterns available for night signalling is very great, the actual use of such equipment in forest-protection communication has been extremely limited. Signal-lanterns are of two principal types, those which form code letters by the display of two colours in the proper sequence, and those which form code letters by flashes of one colour only, showing dots and dashes as with the heliograph. The range of the first class is entirely too short to be of any use in forest protection. The second class offers greater possibilities.

Flash lanterns for signalling purposes are available, using as the source of light acetylene gas, oil, gasolene, limelight, and both incandescent and electric arc lamps. Two principal types are employed; those which burn continuously and operate with a screen like a fixed-flash heliograph, and those which operate with a key and burn intermittently only. The oil, gasolene, limelight, and arc lamps are of the first type. The acetylene and incandescent lamps are of the second type.

#### 1—TYPES OF SIGNAL-LANTERNS

Signal-lanterns of various forms are employed principally for military and naval communication purposes. The ordinary electric searchlight makes an excellent signal-lantern and can be used either behind a screen for the sending of Morse signals, or the beam can be used to send wigwag signals even between stations that are not themselves intervisible. It is not, however, a practical lamp for forest communication because of the large amount of power required for its operation, not to mention its great weight and lack of portability.

Among readily portable signal-lanterns two principle types are available. These are the acetylene lantern, and the electric signal-lantern using dry cells as a source of power. Both have to a limited extent been employed in forest-protection communication.

(a) *Acetylene Lamps.*—The acetylene signal-lantern is used extensively by the American Army Signal Corps, and the most readily procurable lanterns of this type are those adopted by that Service. Two sizes, the field lantern and the station lantern, are employed. For lookout use the station lantern, which is the larger, is preferable as it is as readily portable as the requirements of this service demand and has by far the longer range.

This lantern is built in the form of a small searchlight with a 5-in., aplanatic lens mirror and 3-in. focus. It is mounted on a suitable tripod and equipped with a special gas-generator, a sighting-tube, and a small reading-lamp, the whole equipment weighing about 20 pounds. The generator is hung to the legs of the tripod beneath the lantern and is charged with 1 pound of calcium carbide and 1 gallon of water. This charge is sufficient for about 5 hours' signalling, and recharging requires only a few minutes.

The sighting-tube in the form of a small telescope is attached to one side of the lantern. It is provided with cross-hairs and is used to direct the beam of light on the distant station. Once the lantern is properly aligned, it requires no further adjustment, in which respect it is much superior to the heliograph.

The supplementary reading-lamp is required with all forms of signal-lanterns, as the intermittent flashes of the signals do not afford light enough for reading or recording messages. It is an acetylene lamp also, securing gas from the generator that supplies the signal-lantern.

This form of lantern may be used with a screen similar to the heliograph screen, but to do so the light must burn continuously during signalling. This more than doubles the consumption of carbide, since one charge of the generator will furnish gas for only 2 hours' continuous light. The speed of operation with a screen is eight to fourteen words per minute.

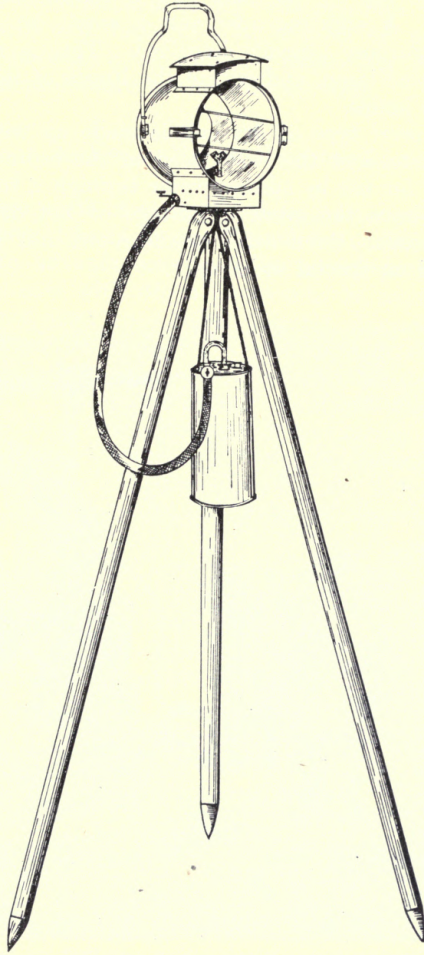

Fig. 106 Acetylene signal-lantern with tripod

As usually employed, the screen is dispensed with and a special form of key is used which controls the supply of gas to the burners. A small amount of gas is admitted continuously. Depressing the key causes a full flow of gas to be admitted to the burner, giving a bright flash lasting as long as the key is held down. The response to the key is instantaneous. Operated in this manner, less carbide is used but the speed is slightly reduced, being about five to ten words per minute. Smoke, fog, rain, and also bright moonlight are the principal impediments to the use of this lantern. The range under ordinary conditions does not exceed 30 miles when viewed with a telescope, and about half this when observed with the naked eye.

(b) *Electric Lamps.*—For comparatively short-distance work the electric signal-lamps, such as are used by the British Army, are very convenient. Such a lamp is the Stevens-Lyon lamp, manufactured in London. This lamp weighs  $10\frac{1}{2}$  pounds

complete and may be mounted on a heliograph tripod. It can be easily read without a telescope at 11 miles. The source of power in electric lamps such as this is the dry cell. In order to reduce battery consumption, all signal-lamps of this character operate with a key or switch, by means of which the circuit is made and broken in such a way as to form the letters of the Morse code. In the Stevens-Lyon lamp this key is placed on the top of the lamp and is shaped like the ordinary Morse key used in telegraphy. A sighting-tube and a small oil reading-lamp are also provided and serve the purpose already described. This is a very compact, easily portable and easily operated lamp, and within the limits of its range might often be preferred to the acetylene lamps.

For use with it the *inert* type of dry cell is made up with the excitant in the form of a dry powder instead of the paste used in the ordinary dry cell. Cells of this type are made ready for use by adding water through a tube placed in the cover for the purpose. They have the great advantage of not deteriorating even when kept stored for long periods. Such cells, however, are not readily procurable and as a rule can be obtained on special order only.

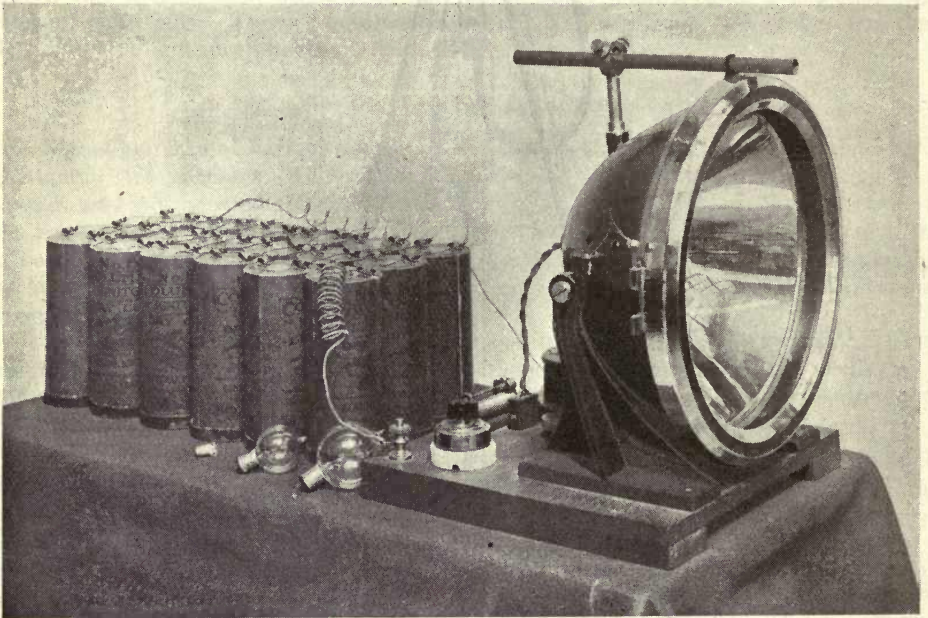

Fig. 107 Fischer high-power electric signalling lamp

(c) *Fischer High-power Lamp*.—The most promising signal-lamp thus far produced is the Fischer triangulation lamp used by the United States Coast and Geodetic Survey as a night signal on its triangulation stations. This lamp employs an 11-in. reflector and, although not as yet fully perfected as to details, it is believed it can be produced to weigh about 24 pounds and to cost under \$50, without the dry cells. Eighteen cells are employed to furnish the current and these will give about 9 hours' continuous service. As used intermittently in signalling they will last a considerably longer period, depending on the amount of such use.

This lamp has the usual sighting-tube, reading-lamp, and switch-key. Its distinguishing feature is a specially designed, gas-filled bulb having a highly concentrated filament which, with a 6-volt,  $2\frac{1}{2}$ -ampere current, gives 250,000 apparent candle-power at 100 ft. The range of this lamp under ordinary conditions is 50 to

75 miles, no telescope being employed, while under exceptionally favourable conditions of atmosphere it has been seen with the naked eye at 100 miles. On a dull day it can be used up to 10 or 15 miles. As with other electric lamps, the speed of sending is somewhat reduced because the filament requires an appreciable time to heat up and cool off. About five words per minute can be sent efficiently.

This lamp with the large number of dry cells required for its operation is not a readily portable equipment and would only be suitable for permanent stations. Difficult accessibility would indicate a necessity for employing either wet batteries or the inert type of dry cell, in preference to the ordinary type.

## 2—USE IN FOREST PROTECTION

Thus far the only use made of signal-lanterns for forest-communication purposes has been on an experimental basis by the United States Forest Service in the state of Washington. Certain advantageous uses for an efficient lamp for lookouts are, however, apparent. The ease with which lamps may be used by one man, requiring, as they do, no adjustment after once being properly aligned, makes them especially valuable for training operators to send and receive flash signals, and for assisting trained men to keep in practice. Of course, the signal-lantern as a means of lookout communication is subject to nearly the same general limitations as is the heliograph, and it cannot be considered as the principal communication equipment on important stations in preference to the telephone, nor can it be depended upon to replace the heliograph. Practically all fires are detected during the day and where visual signals are depended upon for communication the principal methods must be available for daylight operation.

Signal-lanterns, however, can be operated from towers, while heliographs cannot, and, owing to the more uniform conditions that prevail at night, they are the most reliable of all means of visual signalling.

Although, as stated, the use of signal-lanterns in forest protection is as yet very limited it would seem that a lantern with sufficient range would find the following application:—

1 To serve about the same purposes at night that the heliograph and flag serve during the day, that is, to afford communication on lookout stations before the installation of the telephone, during temporary interruptions of telephone service, or on intermediate temporary stations which are not of sufficient importance to justify the provision of telephone equipment, or stations being occupied experimentally.

2 To serve as a specially convenient instrument for training and practice in the sending and receiving of flash signals.

3 To make possible the speedy report of fires detected just before sunset. These are particularly numerous in regions where much land clearing is going on.

4 To make possible the speedy report of such fires as are detected at night. Night detection is, however, rare.

5 On a dull day when the heliograph cannot be employed the lantern may be used for short-range communication. With the Fischer lamp, daylight signals may be sent about 10 miles.

6 To report at night, fires that were detected during the day but could not be reported immediately because lack of sunlight prevented the operation of the heliograph. Also, messages not urgent in character, such as orders for supplies, personal messages, etc., may be sent at night.

The signal-lantern is inferior to the heliograph in the following respects:—

1 Its daylight operation is very uncertain and very limited in range.

2 It cannot be used for communication with a moving patrol because of the practical impossibility of picking up stations at night unless their position has been determined and sighted upon before nightfall.

3 It is slower in operation. This, however, is probably more than offset with poorly trained operators by the fact that once aligned the lantern needs no further adjustment.

4 At mountain lookouts and other stations difficult of access, the providing of sufficient electric cells or other source of light may be inconvenient.

The signal-lantern, therefore, can be successfully used only as an adjunct to the heliograph in situations where the latter is the principal or only means of communication, and only for the purpose of communication between lookout stations or from a lookout to a lowland headquarters on the telephone system. For this purpose a lamp with a great range, a moderate weight, and a reasonable first cost and power charge is essential. These requirements would seem to be met best by the Fischer triangulation lamp of the United States Coast and Geodetic Survey.

## CHAPTER XXII

### FLAG

#### Section 118—General Remarks

The flag as a means of communication is far less applicable to forest protection than to military operations. Its principal value lies in the extreme simplicity and cheapness of the equipment required, and in the fact that it may be readily improvised and can therefore always be available. It is, further, a convenient signalling device with which to instruct new men and keep trained men in practice. The range over which it may be used is so limited, however, that in most forest work the place it might occupy will be taken by either an emergency telephone line or a messenger service.

The flag is a day signalling device like the heliograph, but unlike the latter it can be employed on dull days as direct sunlight is not essential. Dust and smoke, however, very greatly limit the range of flag signals, and may act as a serious obstacle to their employment.

#### Section 119—Equipment Required

Flags should be of linen or cotton cloth or some similar smooth material. Galatea and near-silk serve admirably. The colours used depend on the background against which the signals are being made. Dark blue is best for a light background; white with a blue or red strip or square in the centre, for a dark background. Sizes used depend on the distance, and run from 2-ft. square to 6-ft. square, which latter is about the largest practicable size. For forest use, it is unnecessary to provide poles, but one edge of the flag should be provided with tapes at intervals of 12-in. by which the flag can be attached quickly to a light pole, cut as required. For temporary stations, flags are preferably made of some mercerized cotton cloth in order to reduce weight and bulk. Two 4-ft. flags of this material can be rolled into a package the size of an ordinary dry cell and will weigh 12 ounces.

#### Section 120—Range and Speed

In military operations, flags are generally read with field-glasses or telescopes. This is seldom practicable in the communication work required in forest protection. The distance at which flags of a given size can be read depends on the nature and colour of the background, the state of the atmosphere, and the power of the telescope employed. The greatest distances are possible on days with a clear atmosphere but the sky lightly overcast with clouds. Lack of sunlight does not prevent the use of flags as it does the heliograph. Smoke and fog, however, are more or less complete

obstructions, according to their density. On the average, wigwag signals with a 2-ft. flag may be read with the naked eye at a distance of  $2\frac{1}{2}$  miles, with a 4-ft. flag at 4 miles, with a 6-ft. flag at 7 miles, and with six-power binoculars at 4 miles, 7 miles, and 10 miles, respectively. More powerful glasses or exceptionally clear atmosphere will extend these distances somewhat, it being generally possible to read a 6-ft. flag at 10 miles with the naked eye in Western Canada. Semaphore signalling with the 2-ft. flags can be read only about 1 to 2 miles.

The speed of sending with flags is greatest with the small flags, using the semaphore alphabet, and least with the very large flag, using wigwag. The former method can be operated at ten to fourteen words per minute, the latter at only four to six words depending on the size of the flags employed.

### Section 121—Use in Forest Protection

Except for instructional and practice purposes, as already indicated, the employment of flags in forest signalling is likely to be limited. The conditions under which they are most likely to prove useful are the following:—

(a) *Across Impassable Barriers.*—Pack outfits on opposite sides of large rivers in flood, and parties unprovided with canoes on opposite sides of lakes, often find a means of communication very desirable.

(b) *Lookout Station to Headquarters.*—When the distance is short and no other means of communication is available, flags may sometimes be employed between permanent lookout stations and district ranger or "smoke chaser" stations at lower levels. This is seldom likely to occur as it assumes that neither the telephone nor heliograph is available.

(c) *Patrolmen to Lookout Stations.*—The extreme portability of the flag makes this use readily practicable and it may often be valuable. An urgent message can thus be sent from a point 5 to 10 miles from the lookout station which might otherwise have to be conveyed by messenger. In a mountain country with the lookout station on a high peak this might involve much time.

In case the attention of the lookout man cannot be attracted with the flag alone, smoke puffs or a small hand-mirror should be used for this purpose. Smoke puffs are made by kindling a small, hot fire and, after it gets a good start, covering it with green grass, leaves, or damp, rotten wood, or earth. A blanket or pack cover should be thrown over this and the smoke released in puffs.

A much better method is to carry in the outfit a good plane mirror about 3 or 4 in. square. Set two stakes so that their tops are accurately in line with the distant station and use these as sighting points in directing the flash on the lookout station. Keep the flag displayed meanwhile, and when the lookout man acknowledges the call by raising his flag or turning on his heliograph proceed with the message.

(d) *Heliograph Stations to Camps.*—Heliograph and other long-distance signalling stations are necessarily placed on elevated points while camps are as a rule in valleys, close to water. It quite frequently happens that the heliograph operator receives a message for the camp foreman to which a reply is expected. This ordinarily involves a trip to camp to deliver the message and a return trip to send the reply. Such distances are usually short, but may be a mile or more, and if the two points are intervisible this delay can be avoided by the use of the flag.

(e) *On Forest Surveys.*—A great deal of time is often lost in survey work because the members of a working party are too far apart to make themselves heard in giving instructions. It is true that much of this is due to poor organization or to poorly trained assistants, but some of it is unavoidable. This is especially true in open country where the members of a party may be a long distance apart. The small flag under these circumstances can be of great value in conveying simple instructions over very much greater distances than the voice will carry.

## CHAPTER XXIII

### USING THE FLAG

#### Section 122—General Remarks

Flag signals are made by either the semaphore or the wigwag system. The former is the more rapid but the latter has by far the greater range, and is the method best adapted to forest-protection uses. Several methods of wigwagging are employed but all agree in having at least two distinct movements of the flag, one representing a dot and the other a dash of the Morse code. A third motion is employed in certain conventional signals as is the long flash or "3" of the Myer code with the heliograph. The wigwag system which employes motions both to right and left is best adapted to the larger flags and therefore to the longer ranges, and should be employed for forest work, although other more rapid methods for short-range work can be easily acquired subsequently.

#### Section 123—Selecting a Station

The general principles stated in Section 106 for the selection of heliograph stations also apply to flag stations. With the latter, greater care must be exercised in determining the colour of the background, since this has a very great influence on the range at which signals may be read.

To determine the colour of the background, first ascertain whether the communicating station is higher or lower than, or on a level with, your own. If it be higher, the background for your signals, viewed thence, will be the colour of the field, woods, etc. behind, and lower than, your flagman. If it be lower, your background will be the colour of the ground, etc. behind, and higher than, your flagman. If the stations are of equal elevation, then the background for your signals will be that directly behind the flagman.

The colour of the flag must contrast as strongly as possible with that of the background. With green or drab, or with earth-covered background, the white flag should be used. The distant station is the best judge of background, and should it indicate the colour of flag wanted, that flag should be used.

The following table shows the extent of horizon for different heights above sea-level; that is, it shows how far an object at the sea-level can be seen.

DISTANCES AT WHICH AN OBJECT AT SEA-LEVEL CAN BE SEEN

Height of the eye above sea-level in feet	Distance in statute miles	Height of the eye above sea-level in feet	Distance in statute miles	Height of the eye above sea-level in feet	Distance in statute miles	Height of the eye above sea-level in feet	Distance in statute miles
10	4	50	9	115	14	300	23
15	5	60	10	130	15	350	25
20	6	70	11	150	16	500	30
30	7	85	12	200	18	700	35
40	8	100	13	230	20	900	40

According to the above figures, an observer whose eye is 30 ft. above sea-level can distinguish an object 7 miles distant, providing it is at the sea-level; but if the object is itself 15 ft. above the sea he can make it out 7 miles + 5 miles = 12 miles.



## Section 124—Wigwag Signalling

Flag, torch, hand lantern, or the beam of a searchlight may be employed.

## 1—MOTIONS

One position and three motions are used. The one position is with the flag or other appliance held vertically, the signalmen facing directly toward the station with which it is desired to communicate.

The first motion (the "dot" of the International Morse code or "1" of the Myer code) is to the right of the sender, will embrace an arc of  $90^\circ$  starting from the vertical and returning to it, and will be made in a plane at right angles to the line connecting the two stations.

The second motion (the "dash" of the International or "2" of the Myer code) is a similar motion to the left of the sender.

The third motion ("front" or "3" of the Myer code) is downward directly in front of the sender and instantly returned upward to the first position. This is used to indicate a pause or conclusion.

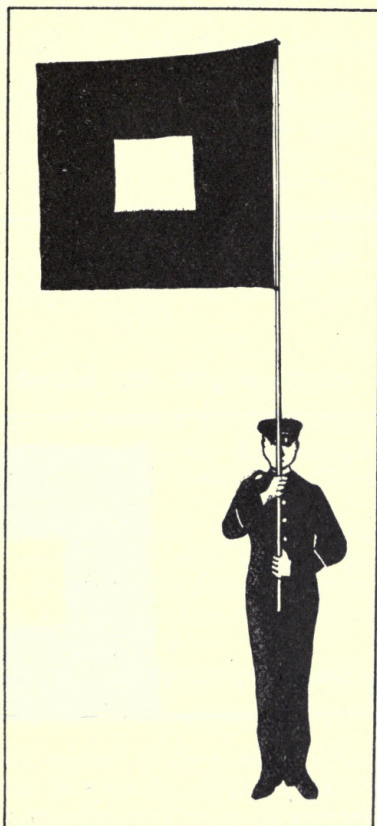

Fig 108. Initial position

## 2—HANDLING THE FLAG

Make all motions rapidly. To prevent entangling of the flag on its staff, skilful handling acquired by practice is necessary. It is accomplished by making a scoop of the flag against the wind, the movement describing an elongated figure 8, thus  $\infty$ . The motions should be made so as to display in the lateral waves the whole surface of the flag toward the point of observation.

Section 121—Wigway Signaling

The torch (and lantern) or the beam of a searchlight may be employed.

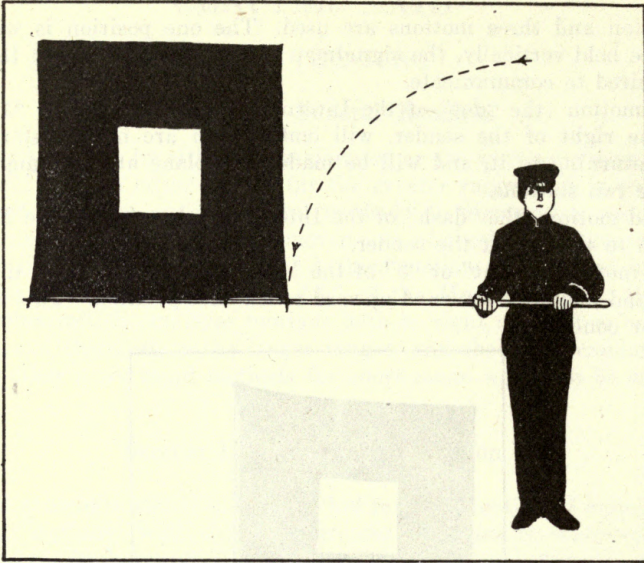

Fig. 109 "Dot" or motion "1"

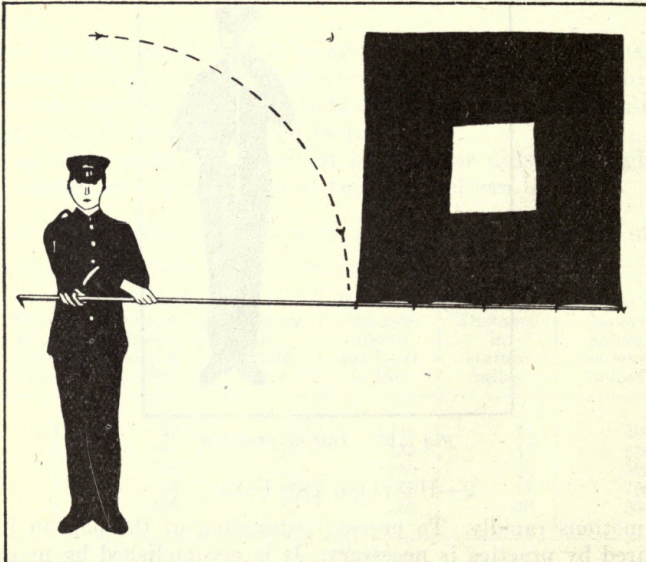

Fig. 110 "Dash" or motion "2"

**Section 125—Rules for Operators and Conventional Signals**

(a) *To call a Station.*—Wave the flag through an arc of 180° in a plane at right angles to the line connecting the two stations until acknowledged (or make the station's call letter, if known).

(b) *To break or stop the signals from the sending station.*—Make the signal QRT front.

(c) *To start the sending station after breaking.*—Make the interrogatory signal followed by the last word received correctly. The sender will then resume his message, beginning with the word indicated by the receiver.

(d) *To acknowledge the receipt of a message*—Signal R front followed by the name or call letter of the receiver.

Each word, abbreviation, or conventional sign is followed by front.

To lessen the liability of error, numerals which occur in the body of a message must be spelled out in full.

CONVENTIONAL SIGNALS.

End of word. . . . .	front.	Repeat last message. . . . .	Interrogatory
End of sentence. . . . .	front, front.		three times.
End of message. . . . .	front, front, front.	Move to your right. . . . .	MR front.
Error. . . . .	AA front.	Move to your left. . . . .	ML front.
Interrogatory. . . . .	---	Move up. . . . .	MU front.
Acknowledgment,		Move down. . . . .	MD front.
or I understand . . . . .	R front	Use your other flag. . . . .	UF front.
Cease signalling. . . . .	QRT front.	Signal faster. . . . .	QRQ front.
Wait a moment. . . . .	---	Signal slower. . . . .	QRS front.
Repeat after (word). . . . .	Interrogatory	Finished (end of work) . . . . .	---
	(word).		

**Section 126—Wigwag Codes**

Any of the codes previously described for the heliograph are equally applicable to flag or wigwag signalling. The "1" of the Myer code is made by a motion to the right, the dot of the International Morse code. The "2" is a similar motion to the left. The front is the "3."

In using the Alphabetical Square code, the number of motions to the right will indicate the first figure of each symbol while those to the left indicate the second figure of the symbols. The front may be used as with the other codes. This code is best adapted to small flags and short ranges, where the motions may be very rapid.

**Section 127—Semaphore Signalling**

1—WITH FLAGS

In this system the letters depend on the position of one or both arms in relation to the body. A point midway between the shoulders may be taken as the centre of a circle, where the arms may be considered as being pivoted so that a complete circle may be described by them. This method is rapid but useful only for distances of 2 miles or less, and requires two flags. It is, therefore, not so well adapted for forest communication as is the wigwag. The semaphore alphabet is shown in Fig. 111.

2—WITH FIXED SEMAPHORE

An interesting application of the semaphore method may be made with a large fixed-semaphore apparatus. This consists of a vertical staff or pole to which are pivoted the signal arms. The pole should be high enough so that it is not obscured

by nearby objects. It may be erected on the roof of a cabin and operated from inside if desired, or if placed on top of a tower it may be operated from the ground. The arms are flat boards which must be at least 3 ft. long, and these must increase 1 ft. in length for each mile over 3 miles at which the semaphore is to be read. As 10-ft

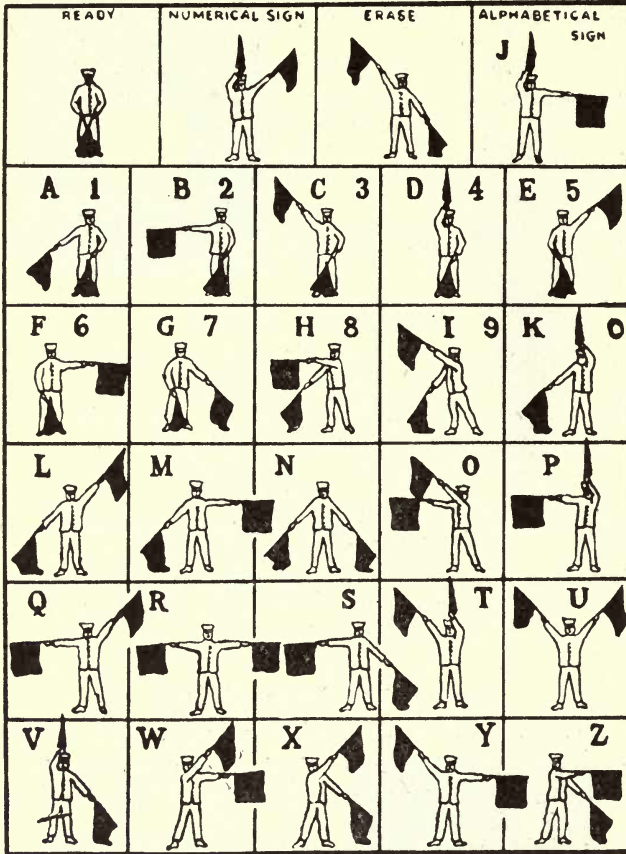

Fig. 111 The semaphore alphabet, numerals, and special signs

arms would probably be about the maximum size that could be erected and manipulated at a forest patrol or lookout station, the range would be limited to 10 miles. The width of the arms should be one-sixth of the length. The arms are moved by a system of levers, ropes, and pulleys. The levers are placed at or near the base of the pole bearing the arms and may reproduce the position of the arms themselves. If the semaphore is to be read from only one direction, the apparatus should be fixed so that the arms move in a plane at right angles to the line connecting the two stations. If it must be read from various directions, it is necessary to place the arms on a revolving shell or casing surrounding the fixed pole and provided with roller bearings at the base; or the supporting pole may be set on a ball-and-socket joint to permit of rotation. For signalling by the semaphore method, only two arms are required and these are fixed on the same pivot near the top of the upright pole. The letters are made by the position of these two arms just as when using flags held in the hands. In addition to the two movable arms it is necessary to have a third shorter fixed arm called the "indicator." This arm is placed on the right of the sender, the left as viewed by the receiver. The code is the same as used with hand flags and is illustrated in Fig. 112.

To signal with the Morse code four arms and the indicator are required. An arm placed at an angle of 45° to the upright post forms a dot of the code; one placed horizontally or at an angle of 90° forms a dash. The signals are read from the top down. The front or "3" of the Myer or Wigwag code is made by dropping all arms to the vertical position. Although limited in range and, except in the smaller sizes, slow to operate, this apparatus may sometimes be found useful on lookout stations, especially those equipped with towers and read from only one direction. The con-

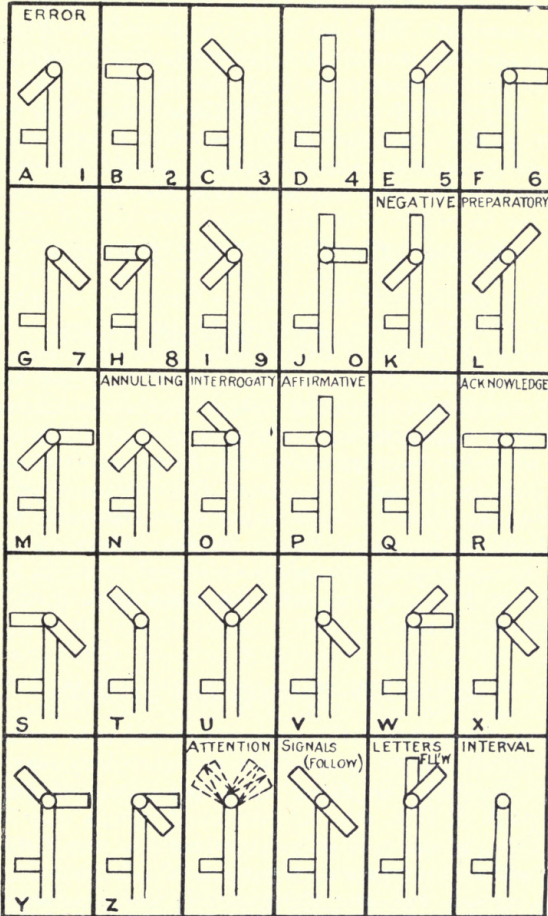

Fig. 112 Two-arm, fixed semaphore code

struction is simple and the signals more easily read than the flag at a similar distance. Code messages are readily set on a fixed semaphore and kept displayed for long periods. In fact, this is by far the most useful application of the fixed semaphore to forest protection, and, as about 650 code messages can be sent using one and two letters only, by building a semaphore with two sets of movable arms on a lookout peak any one of the 650 messages may be set on the semaphore and left displayed to the view of the entire protection staff within range of the station. The arms should be painted according to the colour of the background against which they are displayed. Yellow or orange with a red strip will generally be found most effective.

## CHAPTER XXIV

### MESSAGE CODES

#### Section 128—Purpose of Codes

Message codes are devised in order that preconcerted phrases or sentences may be expeditiously transmitted. They are widely employed in various lines of activity and can be made extremely useful in forest-protection communication, especially where methods of communication other than the telephone are relied upon and the operators have had only limited training. In these codes, one, two, or three letters of the alphabet are used to designate each prearranged sentence, and by having a well arranged copy of the code at each station it is possible to send and receive whole sentences or messages in the time needed to transmit only these one, two, or three letters.

#### Section 129—Use in Forest Protection

A message code is particularly adaptable to forest fire detection work. The first code used in forest protection was employed by the author, with lookout stations equipped with heliographs, in 1909. Others have since been devised, the latest being that of the United States Forest Service in District 1, issued in May, 1916. To a certain extent it is necessary to devise a code to fit the conditions of operation, and the main problem lies in anticipating the messages that it will be necessary for the operator to send. Thus far, message codes have been employed only for the sending of messages from lookout stations. A code of this sort is given in the "Dominion Forestry Branch Message Code" (see note below). This code will be employed for signal communication on Dominion forest reserves wherever signal equipment is installed. If it is found necessary to alter or extend it to fit local conditions this may readily be done by following the rules for preparation given in the "Dominion Forestry Branch Message Code."

#### Section 130—Combinations Available

With two letters of the alphabet in each signal and with no repetition of a letter in any display, 624 combinations are possible, and each may represent a prearranged phrase, sentence, or message. By using the single letters of the alphabet and also such combinations as A A, B B, etc. 52 additional signals may be obtained, making 676 in all. From these, however, it will be advisable to eliminate the various letters and combinations used as conventional signals in the International and other codes, but there will still remain well over 650 available combinations.

Six hundred and fifty phrases give a range of possibilities that covers rather fully the urgent messages that need to be sent by one lookout man to another, or to headquarters, and the saving in time is apparent when it is considered for instance that by sending simply two code letters the lookout man may be enabled to transmit such a message as: "I have sighted a fire, the azimuth bearing of which from my station is 24 degrees."

If 650 signals are not sufficient, by using combinations of three letters in addition to those composed of one and two, more than 16,000 different signals are made available.

*Note—The preceding sections deal with codes in general, their purpose and scope. The particular code prepared for the use of the officers of the Dominion Forestry Branch is, for convenience, published in the form of a small, separate book entitled "Dominion Forestry Branch Message Code."*

## CHAPTER XXV

### DANGER SIGNALS

#### Section 131—Risk in Fire-fighting

Fighting forest fires in heavy timber is a work attended with considerable hazard. Injuries caused by falling trees are frequent, but loss of life is generally due to crews being cut off by fires of the existence of which in their near vicinity they were unaware; or by the sudden development of dangerous conditions in the fire they are themselves fighting, due to high winds or other causes. Nearly 100 men were thus burned or suffocated in the National Forests of Northern Idaho in 1910. Loss of life among fire-fighters has occurred to a certain extent in nearly every region where an aggressive effort is being made to protect the forests from this enemy. This is, of course, in addition to the loss of lives among settlers and inhabitants of forest communities in regions where forest protection staffs either do not exist or have not the organization and efficiency required to protect the community and confine losses to the active field forces who must necessarily take certain risks.

#### Section 132—Use of Danger Signals

In order to guard fire-line crews as much as possible from the risk attendant upon the sudden development of dangerous conditions several protective organizations have considered it advisable to adopt a simple code of danger signals to be used only in case of great emergency on the fire-line. Such signals must be easily made with equipment that can be available at all times, and must be of such a character that they can be conveyed simultaneously to all the men working on a fire-line of the usual length. To avoid any chance of signals being given improperly or by unauthorized persons, it is preferable to have them made by some instrument not likely to be in the possession of such persons. The signals that best meet these requirements are revolver shots or whistle blasts. The distance over which shots may be heard in the woods varies with the wind direction, the size of the cartridge, the intervening topography, and the outside noises. In ordinary timber on level ground, with no wind or unusual noises, the report of a .38-calibre revolver may be heard at a distance of  $\frac{1}{2}$  to 1 mile. Whistle blasts vary with the kind of whistle employed and also with the wind, topography, and outside noises. The type known as a two-tone police whistle may be heard under the conditions described above at a distance of 200 yards.

Signals of this kind are useful, of course, only to the actual fire-fighting forces. Where, as is usually the case, the forest-protection staff also has the duty of providing for the safety of forest communities, the general forest intercommunication system and the discipline of the staff itself must be relied upon to safeguard these interests.

#### Section 133—Code of Danger Signals

The following code of danger signals has been adopted by the forest officers in the National Forests of the State of California and will also be employed by officers of the Dominion Forestry Branch. All men going on the fire-line should be instructed in these signals and the officer in charge of the fire will carry a revolver or automatic pistol or a suitable whistle.

— — — — — (A series of any number of single shots or short whistle blasts with intervals of not less than two seconds between each)—“The fire is in a dangerous condition. Escape by running *down hill*.”

--- (A series of any number of double shots or double whistle blasts with intervals of not less than two seconds between each pair)—"The fire is in a dangerous condition. Escape by running *up hill*."

----- (A series of more than two single shots, generally the gun-fall or discharges as close together as possible.)

or  
 \_\_\_\_\_ (A series of more than two long whistle blasts with intervals of not less than 4 seconds between each, repeated until a response is received)—"Assemble at this point."

**Section 134—Miscellaneous Uses of Shot and Whistle Signals**

The usefulness of shot and whistle-blast signals is not, however, confined to warnings on fire-lines, although in the vicinity of fires they should be used for no other purpose, in order to avoid any chance of confusion. Both, however, may be used to advantage by survey parties, cruisers, packers, and others. In hunting strayed horses, for instance, it often saves much inconvenience and loss of time if the man who first locates the stock conveys news of the fact to the others engaged in the hunt by shots or whistle blasts. Many other cases are constantly arising in forest work where such signals may be used to very great advantage and with much gain in efficiency. A striking example is in the work of "pulling wire" when building telephone lines, and in "pulling slack" on tree lines. A simple code of shot signals should always be arranged by wire-pulling crews so that the man watching the reel can signal the pulling crew to stop, start, or come back, as may be necessary.

It is in fact the duty of every leader of a party in the woods to study the conditions under which his men are working and to devise a simple code of audible signals by which they may communicate with each other, using as the signal-producing mechanism the handiest equipment in the outfit. Under most conditions this will be a six-shooter or an automatic pistol.

**APPENDIX A**

**OUTFIT FOR TELEPHONE CONSTRUCTION CREW**

The tools and supplies required for the construction of a telephone line will vary somewhat according to whether a tree line or a pole line is to be built. The size of the crew will probably vary also. In the following lists, however, a ten-man crew including foreman, cook, and teamster has been taken as the basis for the calculations. Provision is made for having all the tools that may reasonably be needed on the job. Makeshift substitutes or special trips for tools not provided at the proper time cost much more than the transportation of a few extra tools.

**1—TEN-MAN CREW FOR TELEPHONE CONSTRUCTION**

*Pole Line—*

- 1 foreman.
- 1 cook.
- 1 teamster or packer.
- 4 linemen (some of the linemen will have to assist in digging holes and setting poles part of the time).
- 2 groundmen.
- 1 utility man.

*Tree Line—*

- 1 foreman.
- 1 cook.
- 1 teamster or packer.
- 3 linemen (some of the linemen may have to be employed part of the time in clearing right of way).
- 3 groundmen.
- 1 utility man.



## 2—LIST OF LINE SUPPLIES

(Material per mile of Standard Grounded Circuit)

## (a) Pole Line—

- 30 poles, 22½ or 25 feet.
  - 320 pounds No. 9 B.W.G., B.B. galvanized-iron telephone wire.
  - 30 12-inch painted oak brackets.
  - 30 regular pony, long-distance, glass insulators.
  - 30 4-inch and 30 6-inch galvanized wire nails.
  - 30 2-inch fence-staples.
- Approximate total weight, 7,900 pounds.

## (b) Tree Line—

- 315 pounds No. 9 B.W.G., B.B. galvanized-iron telephone wire.
  - 55 standard, porcelain, split tree insulators.
  - 55 4-inch or 3-inch iron staples.
  - 5 pounds No. 12 B.W.G., B.B. galvanized-iron telephone wire.
- Approximate total weight, 350 pounds.

NOTE.—Additional materials must be provided for braces, guys, and special construction, if any, according to the conditions in each individual case.

## 3—LIST OF STATION SUPPLIES

(Material required per Station)

## (a) Standard Indoor Installation—

- (For trade description of supplies see List of Standard Equipment, Section 44.)
- 1 1317-S type telephone set.
  - 3 dry cells.
  - 40 ft. No. 14 B. & S. gauge, rubber-covered, weather-proof, copper wire.
  - 10 ft. No. 19 B. & S. gauge, rubber-covered weather-proof copper wire.
  - 1 standard protector.
  - 2 standard protector micas.
  - 4 standard protector blocks.
  - 1 7-ft. standard, galvanized-iron ground rod.
  - 1 12-inch oak bracket.
  - 1 standard glass insulator.
  - 6 No. 4½ porcelain knobs.
  - 6 3-inch flat-head wood screws.
  - 2 porcelain tubes, 6 by ¾ by 1¼ inches.
  - 5 1½-inch blued, round-head screws.
  - 20 ⅝-inch Blake insulated staples.
  - 2 7-ampere tubular line fuses (required only with 58-F type protector).
  - 1 asbestos protector mat (required only with 58-F type protector).

## 2 ft. brass oilcloth binding.

- 1 howler (required only for receiving vibratory signals).
  - 1 condenser (required only for receiving vibratory signals).
- Approximate total weight, 50 pounds.

## (b) Standard Outdoor Installation—

- 1 1336-J type telephone set.
  - 4 3-inch galvanized-iron lag screws.
  - 2 wooden cleats, 3 by 4 by 18 inches.
  - 8 6-inch wire nails.
  - 1 protector mounting-box.
  - 1 60-E type protector.
  - 4 standard protector blocks.
  - 2 standard protector micas.
  - 1 S.P.S.T. baby knife-switch.
  - 5 2-inch blued, round-head screws.
  - 30 feet No. 14 B. & S. gauge, rubber-covered, braided and weather-proofed, copper wire.
  - 1 7-ft. galvanized-iron ground rod.
  - 30 ⅝-inch Blake insulated staples.
  - 2 dry cells.
- Approximate total weight, 115 pounds.

## 4—LIST OF CONSTRUCTION TOOLS

## (a) Pole-line Construction—

- 1 long-handled, round-pointed shovels.
- 5 7-ft. digging spoons.
- 1 standard tree-trimmer.
- 5 combined digging and tamping bars.
- 1 standard post-hole auger.
- 3 double-bitted axes with handles.
- 1 brush-burning torch (where needed).
- 4 reversible splicing clamps.
- 5 8-inch linemen's pliers.
- 4 pairs eastern climbers with pads and straps.
- 4 linemen's belts with safety straps.
- 5 hand-axes, Hudson Bay pattern.
- 2 Buffalo grips with pulleys.
- 1 Haven clamp.
- 1 3-inch double pulley block (with one hook).
- 1 3-inch double pulley block (with hook and eye.)
- 35 ft. ⅝-inch sash cord.
- 35 ft. ¾-inch sash cord.
- 1 wire-reel.
- 1 pole support (for poles 35 feet and over, only).
- 4 pike-poles (for poles 30 feet and over, only).
- 1 12-inch monkey wrench.

## (a) Pole-line Construction—Con.

- 1 carborundum grinder.
  - 2 double-bitted axe-handles.
  - 1 brace and ⅝-inch bit (12-inch twist, 6-inch shank).
  - 3 carborundum whetstones, 4-inch.
  - 6 10-inch flat files.
  - 1-12-inch wood rasp.
- Approximate total weight, 380 pounds.

## (b) Tree-line Construction—

- (When an occasional pole will have to be set on a tree line, sufficient pole-setting tools to handle the work must be included in the outfit.)
- 8 double-bitted axes with handles.
  - 1 cross-cut saw (2-man).
  - 2 steel felling wedges.
  - 1 peavy.
  - 1 brush-burning torch.
  - 3 reversible splicing clamps.
  - 4 8-inch linemen's pliers.
  - 3 Eastern climbers with pads and straps.
  - 3 linemen's belts with safety straps.
  - 4 hand-axes, Hudson Bay pattern.
  - 3 standard tree-trimmers.

4—LIST OF CONSTRUCTION TOOLS.—*Continued.*(b) *Tree-line Construction—Con.*

- 1 wire-reel.
- 1 carborundum grinder.
- 6 carborundum whetstones, 4-inch.
- 12 10-inch flat files.
- 12 8-inch flat files.
- 1 saw-filing and saw-setting outfit.
- 1 12-inch wood rasp.
- 4 double-bitted axe-handles.
- Approximate total weight, 185 pounds.

(c) *Emergency-line Construction—*

(The requirements vary according to the type of construction attempted. This list is the maximum for a line hung on trees or bush, and in a pinch most of these tools can be omitted.)

- 1 pair 6-inch side-cutting pliers.
- 1 emergency wire-reel.
- 2 hand-axes.
- 1 crook-stick.
- 1 roll friction tape.

(c) *Emergency-line Construction—Con.*

- 1 ball cotton twine.
- 60 3-inch nails.
- 1 pair climbers.
- Approximate total weight, 17 pounds.

(d) *Station Installation—*

- 1 carpenter's hammer.
- 1 8-inch screw-driver.
- 1 4-inch screw-driver.
- 1 brace and  $1\frac{1}{16}$ -inch bit (12-inch twist, 6-inch shank).
- 1 gasoline blow-torch.
- 1 quart gasoline.
- 1 soldering copper.
- 1 pound resin-core solder.
- 1 roll friction tape.
- 1 pair 5-inch oblique, side-cutting pliers.
- 1 pair 6-inch long-nosed pliers.
- 1 monkey-wrench.
- 1 knife, electricians'.
- Approximate total weight, 16 pounds.

## 5—LIST OF TENTAGE

- 1 12-by-14-ft. wall tent with fly (cook tent).
- 1 12-by-14-ft. wall tent with fly (mess tent).
- 3 7-by-9-ft. wall tents (sleeping tents).
- Approximate total weight, 350 pounds.

## 6—LIST OF PROVISIONS

(Ten men for ten days—100 rations)

- |  |  |
|--|--|
| Flour, 100 pounds.   | Macaroni, 2 pounds.                          |
| Cured meats, 75 pounds (if fresh meat is available, use 50 pounds cured, 25 pounds fresh). | Corned-beef, 2-pound cans, 5 cans.           |
| Potatoes, 100 pounds.  | Tomatoes, 2½-pound cans, solid pack, 8 cans. |
| Beans, 20 pounds.  | Peas, 2-pound cans, solid pack, 5 cans.      |
| Sugar, 40 pounds (if syrup is preferred, reduce sugar accordingly).                        | Corn, 1-pound cans, solid pack, 10 cans.     |
| Lard, in 5-pound pails, 10 pounds (if fresh meat is used increase lard to 15 pounds).      | Sauerkraut, 3 pounds.                        |
| Graham flour, 5 pounds.  | Rolled oats, 10 pounds.                      |
| Pancake flour, 6 pounds.   | Cornmeal, 5 pounds.                          |
| Salt, 3 pounds.  | Eggs, 10 dozen.                              |
| Baking powder, 3 pounds.   | Ketchup, 2 bottles.                          |
| Soda, 1 pound.   | Pickles, sour, 1 kit (or 2 gallons).         |
| Yeast cake, 1 packet.  | Mustard, ground, 4-oz. can.                  |
| Butter, creamery, 1-pound cartons, 10 pounds.  | Pepper, ground, 8-oz. can.                   |
| Dried fruits, 20 pounds.   | Cinnamon, ground, 4-oz. can.                 |
| Rice, 5 pounds.  | Allspice, ground, 4-oz. can.                 |
| Coffee, ground, good grade, 1-pound sealed tins, 10 pounds.                                | Lemon extract, 4-oz. bottle.                 |
| Tea, 1 pound.  | Vanilla extract, 4-oz. bottle.               |
| Cocoa, ½-pound cans, 2 pounds.   | Vinegar, 1-quart bottle.                     |
| Cheese, 5 pounds.  | Soap, laundry, 5 pounds.                     |
| Milk, carnation grade, 48 cans.  | Matches, 3 small packages.                   |
|  | Candles, 2 pounds.                           |
|  | Coal oil, 1 gallon.                          |
|  | Chloride of lime, ½-pound cans, 4 cans.      |
|  | Onions, 10 pounds.                           |
|  | Approximate total weight, 550 pounds.        |

## 7—LIST OF KITCHEN EQUIPMENT

(Crew of 10 men, including foreman and cook)

- |   |                                       |
|---|---------------------------------------|
| 1 lantern.  | 1 granite coffee-pot, 8-quart.        |
| 2 single-bitted axes.                                   | 1 granite tea-pot, 3-quart.           |
| 1 sheet-steel cook-stove, No. 8, with 6 joints of pipe. | 2 dishpans, 14-quart.                 |
| 4 frying pans, assorted sizes.                          | 1 granite rice-boiler, 6-inch.        |
| 2 granite kettles, 12-quart, with covers.               | 2 dripping-pans to fit oven of stove. |
| 4 granite kettles, 6-quart, with covers.                | 1 can opener.                         |
| 2 granite stew-kettles, 6-quart, with covers.           | 1 rolling pin.                        |
|   | 4 tin wash basins.                    |

7—LIST OF KITCHEN EQUIPMENT.—*Continued.*

4 tin water-pails, 10-quart.	5 yards 12-ounce duck or light canvas, 36-
3 tin dippers, 1-quart.	inches wide (this item is intended to be
1½ dozen retinned plates.	used for tops for table frames built of
1½ dozen retinned cups and saucers.	light poles. Narrow strips of wood, like
½ dozen retinned dish-up basins, 2-quart.	lath, 36-inches long, should be tacked to
½ dozen retinned dish-up basins, 1-quart.	the canvas ½-inch apart. The cover thus
1 dozen porridge bowls.	made can be kept clean quite easily and
1 retinned syrup pitcher, 1-quart.	may be rolled up into a compact bundle
1 retinned cream pitcher, 1-quart.	and readily packed from one camp to an-
2 butcher knives, one 10-inch, one 12-inch.	other. Two covers are provided—for
1 butchers' steel.	mess table 9 feet long and for cook's
1 meat fork.	table 6 feet long).
2 retinned stirring spoons.	½ pound 10-ounce tacks.
1 meat saw.	10 pounds assorted nails.
4 tin milk pans, 5-quart.	1 carpenters' hammer.
1½ dozen wood-handled, steel knives and	1 carpenters' hand-saw.
forks.	1 alarm clock.
1½ dozen tea-spoons.	10 yards unbleached muslin.
1½ dozen table-spoons.	10 yards crash towelling.
1 5-gallon can, galvanized iron.	Approximate total weight, 325 pounds.

NOTE.—The lists of tents, provisions, and kitchen outfit are taken from "Trail Construction on the National Forests," issued by the United States Forest Service.

## APPENDIX B

## USEFUL BOOKS OF REFERENCE

## 1—SCIENCE OF TELEPHONY

"American Telephone Practice" by Kempster B. Miller, published by McGraw-Hill Book Co., 239 West Thirty-ninth St., New York City, U.S.A.—price, \$4.

"Practical Telephone and Guide to Telephone Exchange" by T. S. Baldwin, published by Frederick J. Drake & Co., 1323 South Michigan Boulevard, Chicago, Ill., U.S.A.—price, \$1.

"A.B.C. of the Telephone" by James E. Homans, published by Theo. Audel & Co., 72 Fifth Ave., New York City, U.S.A.—price \$1.

"Telephone Engineering" by James E. Homans, published by Theo. Audel & Co., 72 Fifth Ave., New York City, U.S.A.—price, \$1.

"Modern American Telephony" by A. B. Smith, published by Fred J. Drake & Co., Chicago, Ill., U.S.A.—price, \$2.

## 2—LINE CONSTRUCTION

"How to Build Rural Telephone Lines," issued by the Northern Electric Co., Montreal, Quebec—price, 50 cents.

"Telephone Construction and Maintenance on the National Forests," issued by the United States Forest Service, sold by the Superintendent of Documents, Washington, D.C., U.S.A.—price 15 cents.

"Telephone Construction Methods and Cost" by Clarence Mayer, published by Myron C. Clark Pub'g Co., 527 South Dearborn St., Chicago, Ill.—price, \$3.

"Electrical Instruments and Telephones of the Signal Corps," issued by the United States Army Signal Corps, sold by the Superintendent of Documents, Washington, D.C., U.S.A.—price, 65 cents.

"Instruction in Army Telegraphy and Telephony," Vol. II, issued by the General Staff, War Office, Great Britain, obtainable from the Department of Militia and Defence, Ottawa—price, 50 cents.

## 3—PREPARATION AND PRESERVATION OF POLES

The following books have been issued by the United States Forest Service, and may be procured from the Superintendent of Documents, Washington, D.C., U.S.A., at the prices indicated:—

“Prolonging the Life of Telephone Poles” (reprint from the Year Book of the United States Dept. of Agriculture, 1905)—price, 5 cents.

“Seasoning of Telephone and Telegraph Poles,” United States Forest Service Circular 103—price, 5 cents.

“Brush and Tank Pole Treatment,” United States Forest Service Circular 104—price, 10 cents.

“Test of Rocky Mountain Woods for Telephone Poles”—price, 5 cents.

“Preservative Treatment of Poles,” United States Forest Service Bulletin 84—price, 15 cents.

## 4—MILITARY SIGNALLING AND TELEPHONY

\*“Training Manual—Signalling” (provisional 1915), issued by the General Staff, War Office, Great Britain; obtainable from the Department of Militia and Defence, Ottawa—price, 25 cents.

“Signalling” by E. J. Solano, published by John Murray, Albemarle St., London, W., England—price, 25 cents.

\*“Manual of Visual Signalling, 1905,” issued by the Signal Corps, United States Army, sold by the Superintendent of Documents, Washington, D.C., U.S.A.—price, 35 cents.

\*“Electrical Instruments and Telephones of the United States Signal Corps,” sold by the Superintendent of Documents, Washington, D.C., U.S.A.—price, 65 cents.

“Instructions in Army Telegraphy and Telephony,” Vol. 1, by the General Staff, War Office, Great Britain, obtainable from the Department of Militia and Defence, Ottawa—price, 50 cents.

\*“Field Telephones for Army Use” by E. J. Stevens, published by Crosby, Lockwood & Sons, London, England—price, \$1.

\*“Field Equipment for Signal Troops,” issued by the Signal Corps, United States Army, obtainable from the Army Signal School, Fort Leavenworth, Kansas, U.S.A.—price, 25 cents.

“The Buzzer and Other Devices for Induction Telegraphy,” issued by and obtainable from the same authorities as the preceding—price, 25 cents.

\*“Signal Book, United States Army” 1916, sold by the Superintendent of Documents, Washington, D.C., U.S.A.—price, 20 cents.

## 5—TELEPHONE TROUBLES

\*Hyde’s “Telephone Troubles and How to Find Them,” published by W. H. Hyde & Co., Milwaukee, Wisconsin, U.S.A.—price, 25 cents.

NOTE.—Most of the books on Telephone Science and Line Construction listed herein contain chapters on the location and clearing of trouble.

## 6—SPECIALIZED FIRE PROTECTION

\*“Fire Protection in District No. 1—Misc. Pub. 0-7,” issued by the United States Forest Service, sold by the Superintendent of Documents, Washington, D.C., U.S.A.—price, 15 cents.

\*“National Forest Fire Protection Plans,” issued by the United States Forest Service, sold by the Superintendent of Documents, Washington, D.C., U.S.A.—price, 15 cents.

## 7—PERIODICALS

“Telephony” (weekly) published by Telephony Publishing Co., 341 Monadnock Block, Chicago, Ill., U.S.A.—price, \$3 per year.

“Western Electric News” (monthly) published by the Western Electric Co., (company organ).

## 8—TRADE CATALOGUES AND HANDBOOKS

“Handbook of Insulated Wires and Cables” issued by Phillips Insulated Wire Co., Pawtucket, R.I., U.S.A.

“The Simplex Manual” issued by the Simplex Wire and Cable Co., 201 Devonshire St., Boston, Mass., U.S.A.

\*“Wire in Electrical Construction” issued by John A. Roebling’s Sons Co., Trenton, N.J., U.S.A.

“Electrical Wires and Cables” issued by the American Steel & Wire Co., Montreal, Quebec.

“Northern Electric Telephone Apparatus and Supplies, Catalogue No. 3” issued by the Northern Electric Co., Montreal, Quebec.

(\*) The books and government documents marked with this symbol will be found particularly suited to those who have made no previous study of telephone science but desire to secure some elementary knowledge of the instruments and of signalling methods in general, with the use that may be made of rapid means of communication in forest protection.

A great deal of useful information may be secured from the trade catalogues issued by the various manufacturers of telephones and telephone supplies and also by the manufacturers of iron and copper wire. These will always be furnished gladly on application, are nearly always profusely illustrated, and often contain much valuable data that is available nowhere else.

## APPENDIX C

## TELEPHONE COSTS

## 1—FACTORS INVOLVED IN THE ESTIMATION OF COSTS OF POLE AND TREE TELEPHONE LINES

The cost of forest-protection telephone lines depends upon so many variable factors that general statements are of very little value. Particularly is this true since the beginning of the European War. Materials and equipment have increased enormously in price, some have even become unobtainable and great delays in delivery must be expected in nearly all supplies. Labour has also both increased in price and to a certain extent decreased in quality. As in other construction work, estimates of supplies must be based on quotations and freight rates to point of delivery. Estimates of transportation away from railways must be based on daily cost of transport equipment, average load, and average daily trip. Estimates of labour must be based on daily wage scale with proper allowance for board, and a knowledge of what constitutes a reasonable day’s task under the existing conditions that to a certain extent differ with each project. This can only be done properly by a study of conditions along the proposed route, coupled with an accurate knowledge of actual costs on similar projects. Classified project costs are being accumulated by the Forestry Branch but as yet are not available for the general information of the field staff.

In preparing an estimate for a telephone line, the costs should be classified under the heads shown in the following schedule:—

1—*Estimating Cost of Pole Lines—*

- (a) Survey of route.
- (b) Tools.
- (c) Line materials.
  - (1) Wire.
  - (2) Insulators, brackets, and nails.
  - (3) Poles.
  - (4) Guys, braces and miscellaneous.
- (d) Station materials.
- (e) Transportation.
  - (1) Wire and miscellaneous supplies.
  - (2) Poles.
  - (3) Camp moving.
- (f) Line clearing.
  - (1) Cutting.
  - (2) Burning.
- (g) Line construction.
  - (1) Digging holes.
  - (2) Setting poles.
  - (3) Pulling wire.
  - (4) Tying in.
  - (5) Miscellaneous adjustments, guys, etc.
- (h) Station installations.
  - (1) Outside work.
  - (2) Inside work.

2—*Estimating Costs of Tree Lines—*

- (a) Survey of route.
- (b) Spotting trees.
- (c) Tools.
- (d) Line materials.
  - (1) Wire.
  - (2) Insulators and staples.
  - (3) Miscellaneous and poles (if any).
- (e) Station materials.
- (f) Transportation.
  - (1) Wire and insulators.
  - (2) Camp moving.
- (g) Line clearing.
  - (1) Cutting.
  - (2) Burning.
- (h) Line construction.
  - (1) Pulling wire.
  - (2) Tying in.
  - (3) Pulling slack.
  - (4) Setting poles (if any).
- (i) Station installation.
  - (1) Outside work.
  - (2) Inside work.

## 2—APPROXIMATE COSTS OF SUPPLIES AND AVERAGE TIME REQUIRED FOR VARIOUS OPERATIONS IN TELEPHONE LINE CONSTRUCTION

(All figures based on quotations in Prairie Provinces prior to the European War)

1—*Supplies—*

- (a) Tools (per ten-man crew).
  - (1) For pole line, \$200.
  - (2) For tree line, \$120.
  - (3) For station work, \$25.
- (b) Line materials (per mile).
  - (1) Wire, No. 9 B.W.G., \$12.
  - (2) Insulators, etc., \$2.
  - (3) Poles, 25 feet, \$18 up.
  - (4) Miscellaneous, \$1 up.
- (c) Station materials each, \$15.

2—*Transportation—*

This is a cost that depends so much on local condition that no average figure has any value. The weight to be transported may be determined from the lists in Appendix A.

3—*Spotting Trees—*

- (a) Very open timber—2 men, 2 miles per hour.
- (b) Very dense timber—3 men,  $\frac{1}{2}$  mile per hour.

4—*Line Clearing—*

This is a cost that depends entirely on local conditions. In general, right of way for tree lines should seldom cost over \$25 per mile for clearing, with labour at 30 cents per hour, but under exceptionally unfavourable conditions may run to \$45 per mile. In fair-sized timber with little underbrush the cost may be as low as \$2 per mile. For pole lines the cost will be materially higher, depending on the width of clearing.

5—*Line Construction, Tree lines—*

- (a) Pulling wire.
  - (1) Best—2 men and 1 horse, 1 mile per hour.
  - (2) Worst—5 men,  $\frac{1}{2}$  mile per hour.
- (b) Tying in.
  - (1) Best— $1\frac{1}{2}$  miles per man, per day.
  - (2) Worst— $\frac{1}{2}$  mile per man, per day.
- (c) Pulling slack—2 men, 1 mile per hour.
 

On pole lines all these costs will be reduced from 15 to 50 per cent.

6—*Erecting Poles, 22½ or 25 feet—*

- (a) Digging holes.
  - (1) Soft ground—1 man, 3 holes per hour.
  - (2) Medium ground—1 man, 1 hole per hour.
  - (3) Hard ground—1 man,  $\frac{1}{3}$  hole per hour.
- (b) Setting poles—3 men,  $2\frac{1}{2}$  poles per hour.
- (c) Attaching lightning-rods—1 man, 4 rods per hour.
- (d) Guying and anchoring—2 men, 2 anchors per day.

7—*Station Installation—*

- (a) Best—1 man, 3 hours (indoor).  
2 men, 2 hours (outdoor).
- (b) Worst—1 man, 5 hours (indoor).  
2 men, 4 hours (outdoor).

## APPENDIX D

### REGULATIONS OF THE BOARD OF RAILWAY COMMISSIONERS FOR CANADA REGARDING WIRE CROSSINGS

#### No. 10—WIRES ERECTED ALONG OR ACROSS RAILWAYS

By section 7 of chapter 22, 1-2 George V (1911), section 4 of chapter 50 of the Statutes of 1910 was repealed, and the following was enacted as subsection 5 of section 246 of the Railway Act:—

“5 An order of the Board shall not be required in cases in which wires or other conductors for the transmission of electrical energy are to be erected or maintained over or under a railway, or over or under wires or other conductors for the transmission of electrical energy with the consent of the railway company or the company owning or controlling such last-mentioned wires or conductors in accordance with any general regulations, plans, or specifications adopted or approved by the Board for such purposes.”

NOTE.—The above applies to construction across the railway only. Where the wires or other conductors are to be erected along the railway, an order of the Board is necessary.

#### General Order No. 231 of the Board of Railway Commissioners

*In the matter of section 246 of the Railway Act, as amended by chapter 37 of the Acts 7-8 George V, section 4, for the carrying of wires and cables along or across the tracks of railway companies under the jurisdiction of the Board.*

Upon the report and recommendation of the Electrical Engineer of the Board,—

*It is ordered:—*

1 That the conditions and specifications set forth in the schedule hereto annexed, under the heading, “Rules for Wires erected along or across Railways,” be, and the same are hereby, adopted and confirmed as the conditions and specifications applicable to the erection, placing, or maintaining of electric lines, wires, or cables along or across all railways subject to the jurisdiction of the Board, part 1 being applicable where the line or lines, wire or wires, cable or cables, is or are carried along or over the railway; part 2 being applicable where the line or lines, wire or wires, cable or cables, is or are carried under the railway.

2 That any order of the Board granting leave to erect, place, or maintain any line or lines, wire or wires, cable or cables, along or across the railway and referring to “Rules for Wires erected along or across Railways,” shall be deemed as intended to be a reference to the conditions and specifications set out in that part of the said schedule which is applicable to the mode of crossing authorized.

3 That any order of the Board granting leave to erect, place, or maintain any line or lines, wire or wires, cable or cables, along or across any railway subject to the jurisdiction of the Board, shall, unless otherwise expressed, be deemed to be an order for leave to erect, place, and maintain the same according to the conditions and specifications set out in that part of the said schedule applicable thereto, which conditions and specifications shall be considered as embodied in any such order without specific reference thereto, subject, however, to such change or variation therein or thereof as shall be expressed in such order.

4 That the general order of the Board No. 113, dated November 5, 1913, approving of "Rules for wires crossing railways," and the conditions and specifications adopted thereby, be, and the same is hereby, rescinded.

May 6, 1918.

H. L. DRAYTON,  
Chief Commissioner.

### Schedule

#### NOTICE TO APPLICANTS

When the interested company's consent cannot be procured and an application to the Board becomes necessary, send to the Secretary of the Board (postage free) with the application, three copies of a sketch or drawing about 8 by 10 in. showing:—

(a) The location of the poles or towers, or the location of the underground conduit in relation to the track; the dimensions of the poles or towers; and the material or materials of which they are made.

(b) The proposed number of wires, or cables, the distance between them and the track and the method of attaching the conductors to the insulators.

(c) The location of all other wires adjacent or to be crossed, and their supports.

(d) The maximum potential, in volts, between wires, the potential between wires and the ground, and the maximum current, in amperes, to be transmitted.

(e) The kinds and sizes of the wires or conductors in question.

(f) On circuits of 10,000 volts, or over, the method of protecting the conductors from arcs at the insulators.

(g) The number of insulators supporting the conductors. (*See also "J" in Specifications.*)

N.B.—Place a distinguishing name, number, date, and signature upon the drawing. Mark the exact location of the lines or wires upon the drawing, by stating the distance in miles from the nearest railway station—N., E., S. or W.—so that this point can readily be identified.

#### STANDARD CONDITIONS AND SPECIFICATIONS FOR WIRE CROSSINGS

##### PART I—OVER-CROSSINGS

###### *Conditions*

1 The applicant shall, at its or his own expense, erect and place the lines, wires, cables, or conductors authorized to be placed along or across the said railway, and shall at all times, at its own expense, maintain the same in good order and condition and at the height shown on the drawing, and in accordance with the specifications hereinafter set forth, so that at no time shall any damage be caused to the company owning, operating or using the said railway, or to any person lawfully upon or using the same, and shall use all necessary and proper care and means to prevent any such lines, wires, cables, or conductors from sagging below the said height.

2 The applicant shall at all times wholly indemnify the company owning, operating, or using the said railway, of, from, and against all loss, cost, damage, and expense to which the said railway company may be put by reason of any damage or injury to persons or property caused by any of the said wires or cables or any works or appliances herein provided for not being erected in all respects in compliance with the terms and provisions of this order, as well as any damage or injury resulting from the imprudence, neglect, or want of skill of the employees or agents of the applicant.

3 No work shall at any time be done under the authority of this order in such a manner as to obstruct, delay or in any way interfere with the operation or safety of the trains or traffic of the said railway.

4 Where, in effecting any such line or wire construction, it is necessary to erect poles between the tracks of the railway, the applicant, before any work is begun, shall



give the railway company owning, operating, or using the said railway at least seventy-two hours' prior notice thereof in writing, and the said railway company shall be entitled to appoint an inspector, under whose supervision such work shall be done, and whose wages, at a rate not to exceed three dollars per day, shall be paid by the applicant. When the applicant is a municipality and the work is on a highway under its jurisdiction, the wages of the inspector shall be paid by the railway company.

4 (a) It shall not, however, be necessary for the applicant to give prior notice in writing to the railway company as above provided in regard to necessary work to be done in connection with the repair or maintenance of the lines or wires when such work becomes necessary through an unforeseen emergency.

5 Where the wires or cables are to be erected at the railway and carried above, below, or parallel with existing wires, either within the span or spans to be constructed at the railway or within the spans next thereto on either side, such additional precautions shall be taken by the applicant as the Engineer of the Board shall consider necessary.

6 Nothing in these conditions shall prejudice or detract from the right of the company owning, operating, or using the railway to adopt at any time the use of electric or other motive power, and to place and maintain along, over, upon, or under its right of way, such poles, lines, wires, cables, pipes, conduits, and other fixtures and appliances as may be necessary or proper for such purposes. Liability for the cost of any removal, change in location or construction of the poles, lines, wires, cables or other fixtures or appliances erected by the applicant along, over or under the tracks of the said railway company, rendered necessary by any of the matters referred to in this paragraph, shall be fixed by the Board on the application of any party interested.

7 Any disputes, arising between the applicant and the said railway company as to the manner in which the said wires or cables are to be erected, placed or maintained, used or repaired, shall be referred to the Engineer of the Board, whose decision shall be final.

8 The wires or cables of the applicant shall be erected, placed and maintained in accordance with the drawings approved by the Board and the specifications following. If the drawing and specifications differ the latter shall govern unless a specific statement to the contrary appears in the Order of the Board.

9 In every case in which the line of a railway company is to be constructed along or under the wires or cables of a telegraph or telephone company, the construction of the telegraph or telephone line or lines of the company shall be made to conform to the foregoing specifications, and any changes necessary to make it so conform shall be made by the telegraph or telephone company at the cost and expense of the railway company.

#### OVERHEAD LINES

##### *Specifications*

A *Labelling of poles.*—Poles, towers, or other wire-supporting structures on each side of and adjacent to railway crossings, to be equipped with durable labels showing (a) the name of the company or individual owning or maintaining them, and (b) the maximum voltage between conductors; the characters upon the labels to be easily distinguished from the ground.

B *Separate lines.*—Two or more separate lines for the transmission of electrical energy shall not be erected or maintained in the same vertical plane. The word "lines," as here used, to mean the combination of conductors and the latter's supporting poles, or towers and fittings.

C *Location of poles, etc.*—Poles, towers, or other wire-supporting structures to be located generally a distance from the rail not less than equal to the length of the poles or structures used. Poles, towers, or other wire-supporting structures must

under no consideration be placed less than 12 ft. from the rail of a main line, or less than 6 ft. from the rail of a siding. At loading sidings sufficient space to be left for driveway.

*D Setting and strength of poles.*—Poles less than 50 ft. in length to be set not less than 6 ft. and poles over 50 ft. not less than 7 ft. in solid ground. Poles with side strains to be reinforced with braces and guy wires. Poles to be at least 7 in. in diameter at the top—mountain cedar poles to be at least 8 in. at the top. In soft ground poles must be set so as to obtain the same amount of rigidity as would be obtained by the above specifications for setting poles in solid ground. When the line is located in a section of the country where grass or other fires might burn them, wooden poles to be covered with a layer of some satisfactory fire-resisting material, such as concrete at least two in. thick, extending from the butt of the pole for a distance of at least 5 ft. above the level of the ground. Wooden structures to have a safety factor of 5.

*E Setting and strength of other structures.*—Towers or other structures to be firmly set upon stone, metal, concrete or pile footings or foundations. Metal and concrete structures to have a safety factor of 4.

*F Length of Span.*—Span must be as short as possible consistent with the rules of setting and locating of poles and towers.

*G Fittings of wooden poles for telegraph, telephone, or similar low-tension lines.*—The poles at each side of a railway must be fitted with double cross-arms, dimensions not less than 3 in. by 4 in., each equipped with 1½-in. hardwood pins, nailed in arms, or some stronger support and with suitable insulators; cross-arms to be securely fastened to the pole in a girth by not less than a ½-in. bolt through the pole; arms carrying more than two wires or carrying cable must be braced by two stiff iron or substantial wood braces fastened to the arms by ¾-in. or larger bolts, and to the pole by a ¾-in. or. larger bolt.

*H Fittings of all poles, towers, or other structures.*—All wire-supporting structures to be equipped with fittings satisfactory to the Engineer of the Board.

*I Guards.*—Where cross-arms are used, an iron hook guard to be placed on the ends of and securely bolted to each. The hooks shall be so placed as to engage the wire in the event of the latter's detachment from the insulators.

*J Insulators.*—All wires or conductors for the transmission of electrical energy along or across a railway to be supported by and securely attached to suitable insulators.

Wires or conductors in 10,000-volt (or higher) circuits, to be supported by insulators capable of withstanding tests of two and one-half times the maximum voltage to be employed under operating conditions. An affidavit describing the tests to which the insulators have been subjected and the apparatus employed in the tests shall be supplied by the applicant. The tests upon which reports are required are as follows:—

*Ja Puncture or rupture test.*—The insulators having been immersed in water for a period of seven days, immediately preceding and ending at the time of the test, to be subject for a period of five minutes to a potential of two and one-half (2.5) times the maximum potential of the line upon which they are to be installed.

*Jb Flash-over test.*—State the potentials that were employed to cause arcing or flashing across the surface of the insulator between the conductor and the insulator's point of support when the surface was (1) dry, and (2) wet.

*K Height of wires (a) Low-tension conductors.*—The lowest conductor must not be less than 25 ft. from top of rail for spans up to 145 ft.; 2½ ft. additional clearance

of rails or other wires must be given for every 20 ft. or fraction thereof additional length of span. The words "low-tension," as here used, to mean conductors for telegraph, telephone, and kindred signal work, as well as conductors connected with grounded secondary circuits of transformers below 350 volts.

Kb All primary conductors, ungrounded secondaries, and railway feeders to be maintained at least 30 ft. above the top of rail—except where special provisions are made for trolley wires.

Kc High-tension conductors, those between which a potential of 10,000 volts or over is employed, to be maintained at least 35 ft. above the top of rail.

L *Clearances.*—Safe clearances between all conductors to be maintained at all times. The following distances to be provided wherever possible; at least 3 ft. clearance from low-tension wires; at least 5 ft. between low-tension wires, primaries, ungrounded secondaries, and railway feeders employing less than 10,000 volts; at least 10 ft. between high-tension wires and all other lines.

M *Guy wires.*—Guy wires at railway crossings to be at least as strong as 7-strand No. 16 Stub's or New British Standard gauge galvanized steel wire, and to be clearly indicated as guy wire on the drawing accompanying the application. One or more strain insulators to be placed in all guy wires; the lowest strain insulator to be not less than 8 ft. above the ground.

Na *Wires and other conductors.*—Where open telephone, telegraph, signal or kindred low-tension wires are strung across a railway this stretch to consist of copper wire, or copper-clad steel wire, not less than No. 13 New British Standard gauge, .092 in. in diameter. Wire is to be securely tied to insulators by a tie wire not less than 20 in. in length and of the same diameter as the line wire.

Nb Where No. 9 B.W.G., or larger, galvanized iron or steel wire is employed in a circuit, and where there is no danger of deterioration from smoke or other gases, the use of this wire may be continued at the crossing.

Nc Where a number of rubber-covered wires are strung across a railway they may be made up into a cable by being twisted on each other or otherwise held together and the whole securely fastened to the poles.

Nd Wires or other conductors for the transmission of electrical energy for purposes other than telegraph, telephone, or kindred low-tension signal work, to be composed of at least seven strands of material having a combined tensile strength equivalent to or greater than No. 4 B. & S. gauge hard-drawn copper wire. These conductors to be maintained above low-tension wires at the crossing, to be free from joints or splices, and to extend at least one full span of line beyond the poles or towers at each side of the railway.

Ne Wires or other conductors subject to potentials of 10,000 volts or over, to be reinforced by clamps, servings, wrappings, or other protection at the insulators to the satisfaction of the Engineer of the Board.

Nf Conductors for other than low-tension work to have a factor of safety of 2 when covered with ice or sleet to a depth of 1 in. and subjected to a wind pressure of 8 pounds per square ft. on the ice-covered diameter.

Ng All conductors to be dead-ended or so fastened to their supporting insulators at each side of the crossing that they cannot slip through their fastenings.

O *Positions of wires.*—Wires or conductors of low potential to be erected and maintained below those of higher potential which may be attached to the same poles or towers.

P *Trolley wires.*—Trolley wires at railway crossings to be provided with a trolley guard so arranged as to keep the trolley wheel or other rolling, sliding or scraping device in electrical contact. The trolley wire, trolley guard, and their supports to be maintained at least 22 ft. 6 in. above the top of the rails.

*Q Cable.*—Cable to be carried on a suspension wire at least equivalent to seven strands of No. 13 Stub's or New British Standard gauge galvanized steel wire. When cross-arms are used, suspension wires to be attached to a  $\frac{3}{4}$ -in. iron or stronger hook, or when fastened to poles to a malleable iron or stronger messenger hanger bolted through the poles, the cable to be attached to the suspension wire by cable clips not more than 20 in. apart. Rubber insulated cables of less than  $\frac{3}{4}$  in. in diameter may be carried on a suspension wire of not less than seven strands of No. 16 Stub's or New British Standard gauge galvanized steel wire. The word "cable" as here used, to mean a number of insulated conductors bound together.

## PART II—UNDERGROUND LINES

### *Conditions*

1 The line or lines, wire or wires, shall be carried along or across the railway in accordance with the approved drawing, and a pipe or pipes, conduit or conduits, cable or cables shall, for the whole width of the right of way adjoining the highway, be laid at the depth called for by, and shall be constructed and maintained in accordance with the specifications hereinafter set forth.

2 All work in connection with the laying and maintaining of each pipe, conduit or cable and the continued supervision of the same shall be performed by, and all costs and expenses thereby incurred be borne and paid by the applicant; but no work shall at any time be done in such a manner as to obstruct, delay or in any way interfere with the operation or safety of the trains, traffic or other work on the said railway.

3 The applicant shall at all times maintain each pipe, conduit or cable in good order and condition, so that at no time shall any damage be caused to the property of the railway company or any of its tracks be obstructed, or the usefulness or safety of the same for railway purposes be impaired, or the full use and enjoyment thereof by the said railway company be in any way interfered with.

4 Before any work of laying, removing, or repairing any pipe, conduit or cable is begun, the applicant shall give to the railway company at least seventy-two hours prior notice thereof, in writing, accompanied by a plan and profile of the part of the railway to be affected, showing the proposed location of such pipe or conduit and works contemplated in connection therewith, and the said railway company shall be entitled to appoint an inspector to see that the applicant, in performing said work, complies, in all respects, with the terms and conditions of this order, and whose wages, at a rate not exceeding \$3 per day, shall be paid by the applicant. When the applicant is a municipality and the crossing is on a highway under its jurisdiction the wages of the inspector shall be paid by the railway company.

4a It shall not, however, be necessary for the applicant to give prior notice in writing to the railway company, as above provided, in regard to necessary work to be done in connection with the repair or maintenance of the line when such work becomes necessary through an unforeseen emergency.

5 The applicant shall, at all times, wholly indemnify the company owning, operating, or using the said railway of, from, and against all loss, costs, damage, and expense to which the said railway company may be put by reason of any damage or injury to person or property caused by any pipe, conduit, or cable, any works or appliances herein, or in the order authorizing the work provided for, not being laid and constructed in all respects in compliance with the terms and provisions of these conditions, or if, when so constructed and laid, not being at all times maintained and kept in good order and condition and in accordance with the terms and provisions of said order, or any order or orders of the Board in relation thereto, as well as any damage or injury resulting from the imprudence, neglect, or want of skill of any of the employees or agents of the applicant.

6 Nothing in these conditions shall prejudice or detract from the right of any company owning or operating or using the said railway to adopt, at any time, the use of electric or other motive power, and to place and maintain upon, over, and under the said right of way such poles, wires, pipes, and other fixtures and appliances as may be necessary or proper for such purposes. Liability of the cost of any removal, change in location or construction of the pipes, conduits, wires, or cables constructed or laid by the applicant rendered necessary by any of the matters referred to in this paragraph, shall be fixed by the Board on the application of the party interested.

7 Any dispute arising between the applicant and the company owning, using or operating said railway as to the manner in which any pipe or conduit, or any works or appliances herein provided for, are being laid, maintained, renewed, or repaired, shall be referred to the Engineer of the Board, whose decision shall be final and binding on all parties.

#### UNDERGROUND LINES

##### *Specifications*

AA *Conduit*.—Vitrified clay, creosoted wood, metal pipe, armoured cable or fibre conduit may be used.

BB *Depth*.—The excavation to be of sufficient depth to allow the top of the duct to be at least three ft. below the bottom of the ties of the railway track.

CC *Laying*.—The conduit or duct to be laid on a base of 3 in. of concrete, mixed in proportion, 1 of cement, 3 of sand, and 5 of broken stone or gravel. Where stone is used, such stone is to be of a size that will permit of its passing through a 1-in. ring. After ducts are laid, the whole to be encased to a thickness of 3 in. on top and sides in concrete mixed in the same proportions as above.

Where the track is on an embankment a pipe may be driven through the latter.

DD *Filling in*.—The excavation must be filled in slowly and well tamped on top and side.

EE *Guard*.—The excavation must at all times be safely protected by the applicant.

## APPENDIX E

### FORESTRY BRANCH STANDARD SPECIFICATIONS

#### 1—Specifications for Galvanizing

(a) *General*.—All iron and steel materials requiring galvanizing shall be prepared according to the following requirements:—

The galvanizing shall consist of a deposition of zinc laid on by either the hot or electric process; this coating shall be evenly and uniformly applied over the entire surface; all holes, grooves, threads, or other irregularities of surface shall be thoroughly coated, and there shall be no excess deposit, rough places, or other imperfections. All galvanizing of parts intended to fit together shall be so performed that such parts can be readily and properly assembled.

(b) *Test*.—All galvanized equipment shall be required to pass the following test, a reasonable quantity of each shipment not to exceed 10 per cent being selected for test and the shipment passed or rejected on the basis of test:—

The sample shall be immersed in the standard solution of copper sulphate for one minute, removed, wiped dry, and cleaned. This process shall be repeated until

four (4) immersions in all have been made, and thereafter if any deposits of copper or any red spots appear on the sample, or if the galvanizing appears corroded or removed, the sample shall be considered defective and the shipment represented by the sample rejected.

(c) *Standard Solution.*—The standard solution of copper sulphate shall consist of a solution of commercial copper sulphate crystals in water having a specific gravity of 1.185 at 70° F. The temperature of the solution shall not exceed 70° F nor fall below 60° F. while the sample is being tested.

## 2—Specifications for Galvanized-iron Telephone Wire

*General description.*—The finished product desired under these specifications consists of galvanized B.B. wire as hereinafter specified.

*Finish.*—The wire shall be cylindrical in form and free from scales, inequalities, flaws, splints, and other imperfections. The finish of the wire shall be in accordance with the best commercial practice. Each coil shall be warranted not to contain any weld, joint, or splice in the rod before drawn.

*Galvanizing.*—The wire shall be well galvanized in accordance with the specifications for the galvanizing of iron and steel given in Specifications No. 1.

### ELECTRICAL REQUIREMENTS

*Electrical resistance.*—The resistance of the wire in ohms per mile—at a temperature of 68° F. shall not exceed the quotient arising from dividing the constant number, fifty-six hundred (5,600), by the weight of the wire in pounds per mile.

### MECHANICAL REQUIREMENTS

*Dimensions.*—The diameter of the galvanized wire shall be within the limits given in the following table:—

Gauge No., B.W.G.	Diameter of galvanized wire, in inches			Gauge No., B.W.G.	Diameter of galvanized wire, in inches		
	Maximum	Gauge	Minimum		Maximum	Gauge	Minimum
6.....	0.207	0.203	0.198	10.....	0.138	0.134	0.130
8.....	0.169	0.165	0.161	12.....	0.112	0.109	0.105
9.....	0.152	0.148	0.144	14.....	0.086	0.083	0.080

*Breaking weight.*—The breaking weight of the wire shall not be less than two and eight-tenths (2.8) times the weight of the wire in pounds per mile.

*Torsion.*—The wire shall be capable of withstanding at least fifteen twists in a length of 6 in.

*Coils.*—The length of the wire in each coil shall be as follows: No. 6 B.W.G., approximately  $\frac{1}{3}$  mile; Nos. 8, 9, 10, 12 and 14 B.W.G., approximately  $\frac{1}{2}$  mile.

In the case of wire less than 0.134 in. in diameter, one-third of the coils may have two pieces to a coil, joined by the ordinary twist joint carefully soldered and galvanized.

In the case of wire 0.134 in. in diameter, and larger, each coil may consist of two pieces only, joined by the ordinary twist joint carefully soldered and galvanized.

*Binding.*—Each coil of wire shall be securely bound in at least four places with galvanized iron wire. A tag shall be attached to each coil giving the size and grade of wire in the coil.

3—Specifications for Hard-drawn Copper Telephone Wire

*General.*—The material shall be copper of such quality and purity that when drawn hard it shall have the properties and characteristics herein required. The manufacture, workmanship, and finish must be in accordance with the best commercial practice.

*Manufacture.*—Each coil shall be drawn in one length and be exempt from joints or splices. All wire shall be truly cylindrical and shall conform to gauge within the limits of variation permitted by these specifications. It must not contain any scale, inequalities, flaws, cold shuts, seams, or other imperfections.

MECHANICAL AND ELECTRICAL REQUIREMENTS

Gauge Nos.	Diameter in mils			Weights per mile in pounds			Breaking wts. in pounds			Wts. of coils, pounds		Conductivity		Twists in six inches	Per cent elongation in five feet.
	Required	Maximum	Minimum	Required	Maximum	Minimum	Actual required	Actual minimum	Per square inch	Maximum	Minimum	Required	Minimum		
B.W.G. 8	128	130	127	260	264	258	818	800	63,100	219	151	$\frac{\%}{97}$	$\frac{\%}{96}$	40	1.05
B. & S.G. 10	101.9	102.8	101.0	165.0	168.0	162.0	540	519	64,800	218	152	97	96	40	0.99
12	80.0	81.2	79.3	102.6	105.7	100.8	334	327	66,500	72	52	97	96	44	0.94
14	64.0	65.0	63.0	65.0	67.5	63.0	220	212	68,200	.....	.....	97	96	47	0.91

*Shipping.*—The wire shall be made up into coils the eye of which shall have a maximum diameter of 22 in. and a minimum diameter of 18 in., and shall be securely tied by not less than four separate pieces of strong twine, and shall be protected by a sufficient wrapping of burlap so that the wire may not be injured during transportation. The wrappings shall be placed upon the wire bundles, after they have been coiled and secured by the twine. Each coil shall have its gauge, length, and weight plainly and indelibly marked upon two brass tags which shall be secured to the coil, one inside the wrapping and the other outside.

4—Specifications for Emergency Wire

*General.*—This wire will be used under all climatic and weather conditions and will be laid out on the ground, or on trees, in continuous lengths not exceeding 30 miles, and without the use of insulators. The quality of the material used and the method of manufacture shall be such as to ensure for the wire the properties herein specified.

*Conductor.*—This wire shall have a conductor consisting of ten strands of No. 30 B. & S. gauge hard-drawn copper wire twisted together, the twists per foot not to be less than eight and not more than ten.

*Hard-drawn Copper Wire.*—The hard-drawn copper wire shall be free from bends, cuts of any dimensions, nicks, splits or splinters, spills, grooves, scraped surface, wavy surface, flat-sided or oval wire, corrosion, or any irregularities. The diameter of No. 30 hard-drawn copper wire shall not be greater than .01013 in. nor less than .00993 in.

*Covering.*—A double reverse serving of cotton shall be applied to the twisted conductor so as to form a close, smooth covering.

*Weather-proofing.*—The cotton covering shall be thoroughly saturated with a permanent weather-proof compound of such a nature as to preserve the strength of the

cotton wrapping, shall not act injuriously thereupon, and shall be insoluble in water. The compound shall adhere firmly to the cotton covering and shall not drop or run when the finished wire is subjected to a temperature of 150° F. for thirty minutes, and shall not crack when the wire is subjected to a temperature of 10° F. for thirty minutes.

The diameter of the completed wire shall not be more than .048 in. and not less than .043 in.

*Spooling.*—The wire shall be evenly wound on wooden spools weighing approximately three-quarters of a pound.

The inner end of the wire shall be brought out through the spool head.

The length of the wire shall be 2,640 ft. plus 100 ft.

The exact length of the wire shall be marked on the spool.

The wire on each spool shall be one continuous length.

*Splices.*—Spliced joints shall be equal to or stronger than the wire itself and shall be so made as not to materially increase the diameter of the conductor at the point where the splice occurs.

*Weight per mile.*—The weight per mile of the finished wire shall not exceed nineteen and a half (19.5) pounds and shall not be less than seventeen and a half (17.5) pounds. This does not include the weight of the wooden spool.

*Tensile Strength.*—Tests shall be made on wire from the ends of which the insulation has been removed. The finished wire shall have a minimum breaking weight of forty-five (45) pounds and a minimum elongation of one-half of 1 per cent in a length of 2 feet.

*Resistance.*—The resistance of this wire shall not be more than 60 ohms per mile at a temperature of 68° F.

## 5—Specifications for Rubber-covered Copper Wire

*General.*—The quality of the material used must be of the best, and the manufacture, workmanship, and finish must be in accordance with the best commercial practice.

*Manufacture.*—The conductor shall be in one continuous length, cylindrical in section, and uniformly drawn, so that the variation over or under the specified diameter shall not exceed one (1) mil (one one-thousandth of an inch). It shall be uniform in quality, free from factory joints, scales, splints, flaws, and other imperfections. To ensure the removal of defects from the conductor the manufacturer shall cut off 25 ft., or as much more as may be necessary, from each end of every coil.

Each conductor before being insulated shall be thoroughly and uniformly tinned. The tin coating must conform to the following requirements: The tinned conductor shall be immersed in a current of pure hydrogen sulphide gas, saturated with water vapour at a temperature of not less than 75° F. and not more than 79° F. for four hours. At the end of this time the conductor must exhibit no signs of blackening.

*Insulation.*—The tinned conductor shall be evenly and smoothly covered with vulcanized rubber of the best quality, which is impervious to moisture, or some other approved weather-proof, insulating compound to such a thickness as hereinafter specified.

The dielectric shall adhere firmly to the conductor and shall not act injuriously upon it. The wire shall be well centred in the dielectric. The dielectric shall not soften sufficiently to allow decentralization at a lower temperature than 130° F.



The insulated conductor shall be sufficiently flexible to stand being twisted three times about itself, left for at least sixteen hours, and untwisted without the dielectric showing any signs of rupture.

*Electrical Requirements.*—The insulation test shall be made on the outside distributing conductor whilst in water, the conductor having been previously submerged in water for at least twelve hours prior to the test. All conductors, No. 16 B & S. gauge and over, shall show an insulation resistance of not less than 500 megohms per mile; and conductors under No. 16 B. & S. gauge shall have an insulation resistance of not less than 250 megohms per mile. The temperature at which test is to be made shall not be less than 60°F. nor more than 70°F.

The test for insulation resistance shall be made with an electro-motive force of not more than 550 volts, the insulation resistance to be figured from the deflection obtained with the negative pole of the source of potential connection to the conductor and after an electrification of one minute. If unequal deflections are obtained with the positive and negative poles connected to the wire, the insulation shall be considered defective.

*Mechanical Requirements.*—These include breaking weight, elongation, and braiding.

The breaking weight for No. 14 B. & S. gauge wire shall not be less than one hundred and ninety (190) pounds; for No. 16 B. & S. gauge wire, not less than one hundred and twenty-five (125) pounds; and for No. 19 B. & S. gauge wire not less than seventy (70) pounds.

The elongation in two feet shall not be less than 1 per cent for No. 14, No. 16, and No. 19 B. & S. gauge wires.

As to braiding, each insulated conductor shall be covered with a close, smooth braid, which shall be thoroughly impregnated with a permanent weather-proof compound. The impregnated braid shall then be uniformly covered with a continuous layer of the compound which shall adhere firmly to the braid.

The compound shall not act injuriously on the dielectric or the braid, and shall not melt when subjected to a temperature of 125° F., nor crack at a temperature of 30° F., and shall be insoluble in water.

*Packing for Shipment.*—The finished conductor shall be delivered in coils of one continuous piece, the eye of the coil to be about nine inches. Both ends of the coil shall be accessible.

Each coil shall be securely bound with strong tape or twine in at least four separate places, and shall then be wrapped with burlap or strong paper to prevent mechanical injury during transportation.

Each coil shall have its gauge and length plainly marked on two strong tags, one tag to be attached to the coil and the other to the outside of the wrapping.

## 6—Specifications for Glass Insulators

The material desired under these specifications consists of glass insulators of the style and dimensions hereinafter described.

*General.*—The specifications and drawings are intended to include all instructions necessary to guide the manufacturer in his work. They are intended to cooperate with and supplement each other so that any details indicated in one and not in the other shall be executed as if indicated in both.

*Workmanship.*—All workmanship shall be of the best commercial grade.

*Material.*—The insulators shall be made of transparent colourless or green glass.

*Dimensions.*—The insulators shall be of the style and dimensions shown in the drawing attached hereto and made part of these specifications.

Where maximum and minimum dimensions are shown the dimensions shall be within the limits specified. Where limits are not shown the dimensions shall be approximate.

The diameter of the thread shall be such that at least two revolutions of the insulator will be required to tighten it on the standard insulator gauge, and when in this position the end of the insulator gauge shall not be more than one-eighth of an inch from the crown of the insulator.

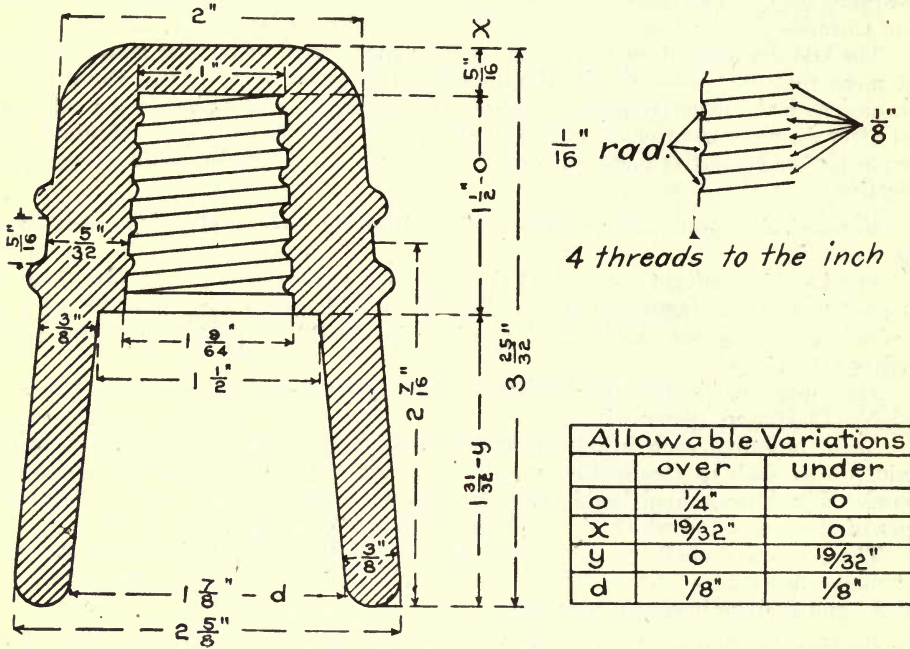

Specifications 6 Design of Forestry Branch standard pony glass insulator

The thread of all insulators shall be smooth and of uniform pitch. The thread shall be well centred in the insulator so that, when in place on the standard insulator gauge, the gauge will not touch the inner surface of the petticoat.

Insulators conforming in all other respects to the requirements of these specifications, but having on the lower edge of their petticoats a series of projecting points, may be accepted under these specifications.

*Finish.*—The insulators shall have a finish ensuring, so far as is consistent with the best commercial practice, smooth even surfaces and freedom from flaws, cracks, blow-holes, sharp edges, and other defects.

### 7—Specifications for Split Tree Insulators

*Material.*—Split tree insulators shall be made of the best grade of insulator porcelain.

*Finish.*—The surface shall be brown-glazed except the faces which are to be placed in contact in attaching the insulator around the line wire. These may be left white and unglazed. The glazed finish shall be smooth, without rough spots, cracks, sharp edges, or other defects.

*Workmanship.*—All workmanship shall be of the best commercial grade.

*Dimensions.*—The insulators shall be of the type and dimensions shown in the drawing attached hereto, and made a part of these specifications.

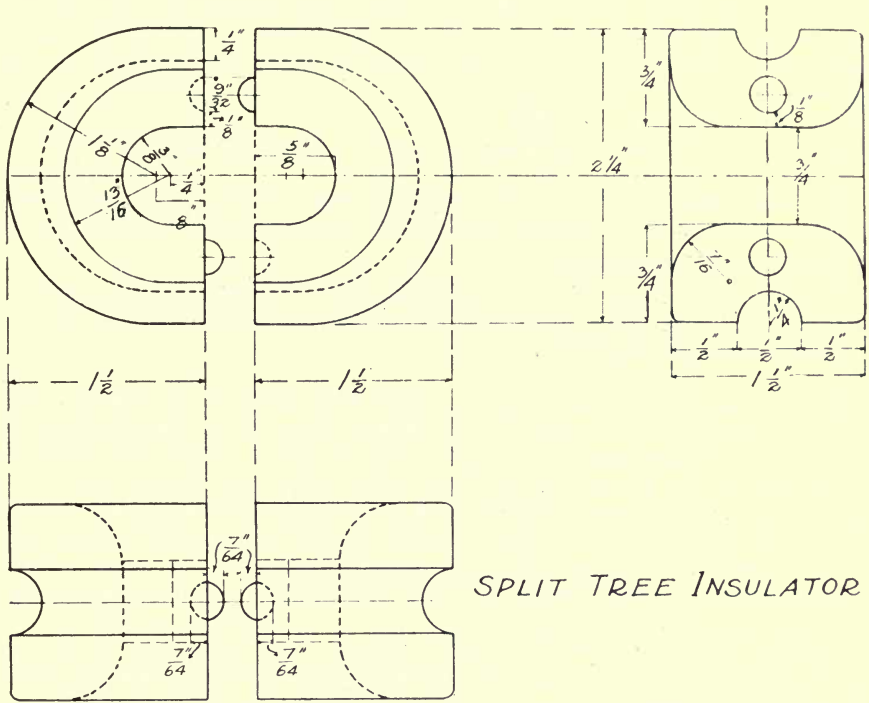

SPLIT TREE INSULATOR

Specifications 7 Design of Forestry Branch' standard split tree insulator

### 8—Specifications for Cedar Poles

Purchased poles not cut under the supervision of the Dominion Forestry Branch shall be required to conform to the specifications of the Northern White Cedar Association if secured east of the Rocky mountains, or to those of the Western Red Cedar Association if secured west of the Rocky mountains. For convenience and reference extracts from these specifications are reprinted below:—

#### *Northern White Cedar Association Specifications*

“Sizes, 4 in., 25 ft. and upwards. Above poles must be cut from live, growing cedar timber, peeled, and reasonably well proportioned for their length. Tops must be reasonably sound, must measure in circumference as follows: seasoned 4-in. poles, 12 in.; 5-in. poles, 15 in.; 6-in. poles, 18½ in.; 7-in. poles, 22 in. If poles are green, fresh cut, or water-soaked, then 4-in. poles must measure 12½ in.; 5-in. poles, 16 in.; 6-in. poles, 19½ in.; 7-in. poles, 22¾ in. in circumference at top end. Lengths may be one-half inch, scant for each 5 ft. in length, and six inches long for any length from 20 ft. up.

“One way sweep allowable not exceeding 1 in. for every 5 ft.; for example, in a 25-ft. pole, sweep not to exceed 5 in., and in a 40-ft. pole, 8 in. Measurement for sweep shall be taken as follows: That part of the pole when in the ground (6 ft.) not being taken into account in arriving at sweep, tightly stretch a tape-line on the side of the pole where the sweep is greatest from a point 6 ft., from the butt to the upper

surface at top, and having so done measure widest point from tape to surface of pole and if, for illustration, upon a 25-ft. pole said widest point does not exceed 5 in., said pole comes within the meaning of these specifications. Butt-rot in the centre including small ring-rot outside of the centre; total rot must not exceed 10 per cent of the area of the butt. Butt-rot of a character which plainly seriously impairs the strength of the pole above ground is a defect. Wind-twist is not a defect unless very unsightly and exaggerated. Rough, large knots, if sound and trimmed smooth, are not a defect."

*Western Red Cedar Association Specifications*

"All poles must be cut from live, growing cedar timber, peeled, knots trimmed close, butts and tops sawed square, tops must be sound and must measure as follows in circumference:—

4-in. top, 12-in. circ.	7-in. top, 22-in. circ.	9-in. top, 28-in. circ.
5-in. top, 15-in. circ.	8-in. top, 25-in. circ.	10-in. top, 31-in. circ.
6-in. top, 18½-in. circ.		

"No pole shall have more than one crook and this shall be one way only, the sweep not to exceed 1 in. to every 6 ft. in length. Same to be determined in the following manner:—Measurement for sweep shall be taken as follows: That part of the pole when in the ground (6 feet) not being taken into account in arriving at sweep, tightly stretch a tape-line on the side of the pole where sweep is greatest, from a point 6 ft. from butt to the upper surface at top, and, having so done, measure widest point from tape to surface of pole and if, for illustration, upon a 30-ft. pole said widest point does not exceed 5 in., said pole comes within the meaning of these specifications.

"Butt-rot in centre, including small ring-rot, shall not exceed 10 per cent of the area of the butt. Butt-rot of a character which impairs the strength of the pole above ground is a defect.

"Large knots, if sound and trimmed smooth, are not a defect.

"A perfectly sound, dead or dry streak shall not be considered a defect when it does not materially impair the strength of the pole."

### 9—Specifications for Wooden Spools for Emergency Wire

The spool on which the emergency wire is to be wound is to be made in accordance with the drawing attached hereto and made a part of these specifications. The material is to be clear, straight-grained, thoroughly seasoned pine; the manufacture

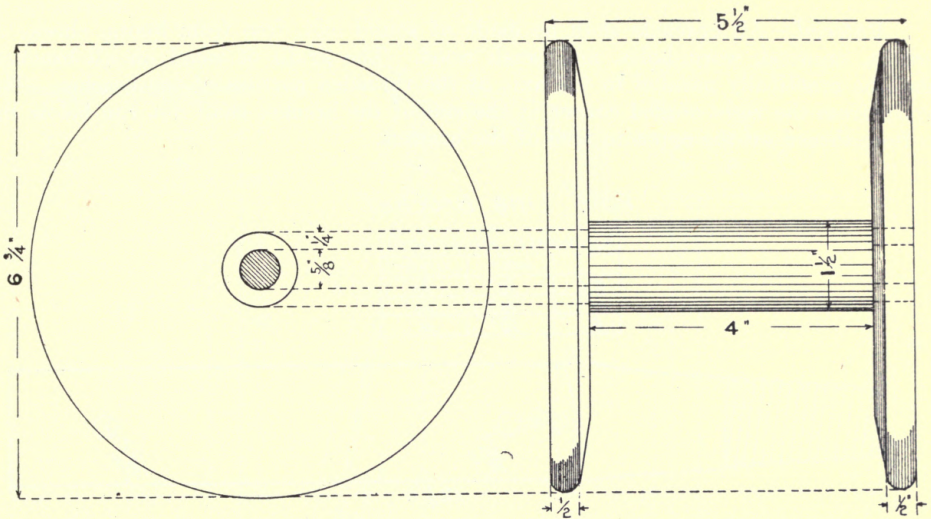

*Sketch of Emergency Wire Spool*

Specifications 9 Design of Forestry Branch standard emergency wire spool

is to be of the best grade and the spools are to be finished with two coats of shellac varnish. The weight of the finished spool should be approximately three-quarters of a pound.

### 10—Specifications for Creosote

The oil used shall be the best obtainable grade of coal-tar creosote, that is, it shall be a pure product obtained from coal-gas tar or coke-oven tar and shall be free from any tar, oil or residue obtained from petroleum or any other source, including coal-gas tar or coke-oven tar; it shall be completely liquid at 38°C. and shall be free from suspended matter; the specific gravity of the oil at 38°C. shall be at least 1.03. When distilled by the common method (that is, using an 8-ounce retort, asbestos-covered with standard thermometer, bulb  $\frac{1}{2}$  in. above the surface of the oil) the creosote, calculated on the basis of the dry oil, shall give no distillate below 200°C., not more than 5 per cent below 210°C., not more than 25 per cent below 235°C., and the residue above 355°C. if it exceeds 5 per cent in quantity, shall be soft. The oil shall not contain more than 3 per cent water.

## 11—Specifications for Wooden Brackets

The articles desired under these specifications consist of oak pole-brackets, fitted to take the standard insulator.

*Workmanship.*—All workmanship shall be of the best commercial grade.

*Material.*—All brackets shall be made of sound oak, free from knots, checks or cracks, sapwood, worm-holes, and brash wood. The grain of wood on all brackets shall be practically parallel to the axis of the threaded portion of the bracket. The grain from the right-angled corner at the end of the bracket shall not run below the bottom thread on the opposite face of the bracket.

## Pole Line Bracket

ALLOWABLE VARIATIONS		
	over	under
$dc$	$\frac{1}{8}$ "	$\frac{1}{16}$ "
$d$	$\frac{1}{8}$ "	$\frac{1}{8}$ "
$e$	$\frac{1}{4}$ "	$\frac{1}{4}$ "

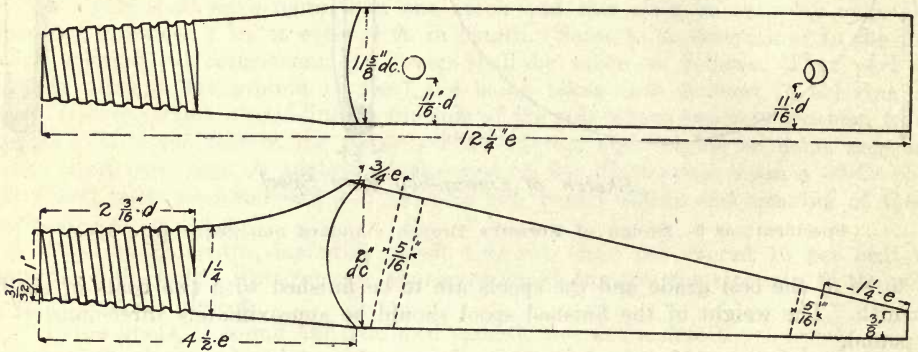

Specifications 11 Design of Forestry Branch standard wooden bracket

All brackets shall be thoroughly seasoned before being offered for inspection.

*Dimensions.*—The seasoned brackets shall be of the style and dimensions shown in the drawing attached hereto and made part of these specifications. Where maximum and minimum dimensions are shown, the dimensions shall be within the limits specified. Where limits are not shown, the dimensions shall be approximate. Figures upon the drawings shall be followed in preference to scale measurements.

*Thread.*—The threaded portion of the bracket shall be as nearly as possible of a circular cross-section. The thread shall be smooth and of a uniform pitch, and such that a standard insulator can be readily screwed on to the bracket until the end of the bracket touches the top of the insulator. When in this position there should be no perceptible rocking or play of the insulator on the bracket.

*Nail holes.*—Each bracket shall have two nail holes as shown in the drawing attached hereto. The nail holes shall be well centred and shall be perpendicular to that face of the bracket which makes an angle with the axis of the thread.

## 12—Specifications for Outdoor Protector Mounting-boxes

The box used for mounting protector and switch for installation outdoors with the 1336—J telephone set shall be made of clear, straight-grained, thoroughly seasoned pine, spruce, or Douglas fir, according to the drawing attached hereto, and made a part of these specifications. Hinges and hasp shall be of brass fastened by brass screws.

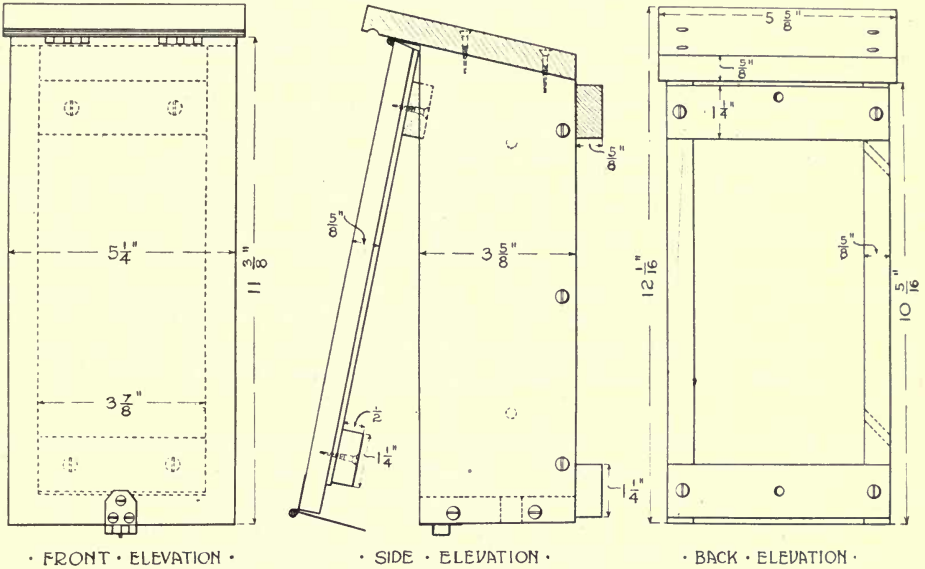

Specifications 12 Design of outdoor protector mounting-box

*Finish.*—The box shall be planed smooth inside and out and treated with a coat American Telephone and Telegraph Co. specifications, as follows: No. 3438 for 40-60 inside and out with two coats of best paint either grey, dark green, brown, or black.

## APPENDIX F

## SOLDERING—METHODS AND MATERIALS

*Approved Solders.*—Approved solders are those made in accordance with the American Telephone and Telegraph Co. specifications, as follows: No. 3438 for 40-60 solder; No. 3439 for 45-55 solder; No. 3440 for 50-50 solder; No. 3441 for resin flux wire solder.

*Approved Fluxes.*—Approved fluxes are: (1) plumbers' candles for plumbing and cable work; (2) resin; (3) the stick forms of flux made by the Northern Electric Co., and (4) that known as "Allen's" stick. No other form of flux (such as paste or liquid soldering salts) is to be used.

*Process.*—All parts to be soldered must first be thoroughly cleaned by scraping, filing, rubbing with emery paper, or some other method. In cleaning galvanized iron, take care not to scrape off all the galvanizing.

Heat the joint with the soldering-iron. Do not attempt to apply the solder with the iron. Heating should be just sufficient to melt the resin of resin-core solder or of the soldering stick, and the parts should then be thoroughly coated with the flux.

Copper rapidly oxidizes when heated in contact with the air, and solder will not adhere to oxidized copper. The purpose of the flux, therefore, is to cover the surface to be soldered while the temperature is still low, and prevent oxidation. Continue the application of the hot iron until the joint has become hot enough to melt the solder which will then flow readily. Do not try to apply resin-core solder with a hot iron and its own flux to a cold surface nor to an oxidized joint.

*45-55 Solder.*—This solder is to be used for joining split sleeves in cable work, and for large surfaces of metal which are to be soldered. It is also to be used in making joints in old galvanized-iron wire, and similar work. In joining old galvanized wire, clean the ends which are to be soldered with emery cloth and make a Western Union joint; then solder by means of a ladle, using as a flux one of the approved stick forms. Do not use more than is necessary to cause the solder to flow, and apply by rubbing before the first pouring of the solder over the joint. If necessary, apply again after the joint has been heated. A large well-tinned soldering iron may be used, if preferred, instead of pouring the solder over the joint. In such a case the iron must be pressed against the joint so as to warm it just enough to melt the flux when it is held against it. After a coating of this has adhered, apply the hot soldering-iron again and, at the same time, apply the 45-55 wire solder to the joint (do not put the solder on the soldering iron). When the solder melts, having derived its heat from the joint and not from the iron, it will flow readily. A slight tap on the wire will help it to run into the joint well. This solder is furnished in the form of  $\frac{1}{8}$ -in. wire in 10-pound coils, or in bars of  $1\frac{1}{2}$  pounds weight, and orders must state in which form it is required.

*Resin Flux Wire Solder.*—Resin flux wire solder is to be used in soldering all wire connections other than galvanized-iron wire, but it may also be used for this purpose in new work, when it is done with a soldering-iron. It is also to be used for all work where copper and brass are to be soldered. To use this solder for small work, such as wire joints and terminals, apply to the joint a well-tinned soldering-iron, of sufficient size for the work. In soldering terminals, first clean off all old solder and bits of wire by means of a hot iron and then give only one turn of the wire which is to be soldered around the terminals. In larger work, use any convenient means to heat the joint, remembering to get a coat of resin on before enough heat has been applied to the metal to oxidize it, and that the metal to be soldered must be hot enough to melt the solder and burn off the superfluous resin. This solder is furnished in 5- and 10-pound coils, and orders must state which size is required.

*To Solder to Black Iron Pipe.*—

- (1) First thoroughly clean a strip on the pipe about  $\frac{1}{2}$ -in. wide and  $2\frac{1}{2}$ -in long;
- (2) Heat the cleaned place, either with the flame of a gasolene torch or a heated iron, until it is hot enough to melt the soldering-stick;
- (3) Distribute a coat of flux over this point by rubbing it with a soldering-stick;
- (4) With a well heated soldering-iron distribute 45-55 solid-wire solder over the cleaned space;
- (5) Tightly wrap the wire, well cleaned, around the pipe, leaving at least  $\frac{3}{8}$  in. between each turn;
- (6) Fasten the end of the wire at the end of the coil by twisting it around the wire leading from the pipe;
- (7) Apply an additional coat of flux;
- (8) Apply the 45-55 solid-wire solder in the regular manner.

*Tinning Soldering-Iron.*—File the iron to the required shape and brightness, and heat until it is only just hot enough to melt the resin of resin-cored solder but not hot enough to change the colour of the bright copper by oxidation. When in this condition, coat the part to be tinned with resin and apply heat until the solder melts readily, when it will be found to flow freely on the iron. Do not let the flame come in contact with the tinned part of the iron.



# APPENDIX G

## USEFUL TABLES

TABLE 1—WEIGHTS OF CEDAR POLES OF VARIOUS LENGTHS AND TOP DIAMETERS

Length	Top diameter	Weight, seasoned	Weight, green	Length	Top diameter	Weight, seasoned	Weight, green
ft.	in.	pounds	pounds	ft.	in.	pounds	pounds
20	4	100	130	45	6	900	1,000
20	5	130	170	45	7	1,100	1,250
20	6	190	250	45	8	1,350	1,500
25	4	150	200	50	6	1,150	1,250
25	5	200	260	50	7	1,350	1,450
25	6	250	325	50	8	1,700	1,850
25	7	350	425				
				55	6	1,350	1,500
30	5	275	350	55	7	1,700	1,875
30	6	350	425	55	8	2,200	2,400
30	7	450	500				
30	8	575	630	60	6	1,700	1,800
				60	7	2,200	2,350
35	5	375	500	60	8	2,500	2,700
35	6	450	600				
35	7	600	750	65	6	2,200	2,450
35	8	850	990	65	7	2,500	2,800
				65	8	3,000	3,400
40	6	625	840				
40	7	850	1,075	70	6	2,500	2,900
40	8	1,100	1,325	70	7	3,000	3,500
				70	8	4,000	4,600

TABLE 2—NUMBER OF POLES OF DIFFERENT SIZES REQUIRED TO MAKE UP A CARLOAD LOT

SINGLE CARS				NUMBER PER LOAD			
Poles	4 in. in diameter	25 ft. long.		Not less than	175 and up to	225	
"	5 "	" 25 "		"	" 150 "	" 200	
"	6 "	" 25 "		"	" 100 "	" 125	
"	7 "	" 25 "		"	" 75 "	" 100	
"	6 "	" 30 "		"	" 75 "	" 100	
"	7 "	" 30 "		"	" 60 "	" 80	
"	7 "	" 35 "		"	" 55 "	" 75	
DOUBLE CARS				NUMBER PER LOAD			
Poles	7 in. in diameter	40 ft. long.		Not less than	60 and up to	75	
"	7 "	" 45 "		"	" 50 "	" 65	
"	7 "	" 50 "		"	" 40 "	" 55	
"	7 "	" 55 "		"	" 35 "	" 45	
"	7 "	" 60 "		"	" 25 "	" 35	
"	7 "	" 65 "		"	" 20 "	" 30	

25s and 30s should be loaded on cars taking a minimum of 24,000 pounds; 35s on cars taking a minimum of 30,000 pounds; double loads (40s and longer), on long cars 30,000 pounds each or 60,000 pounds minimum for the double load.

All poles up to and including 7 inches, 35 feet, are loaded on single cars. All poles over 35 feet in length are loaded on double cars.

TABLE 3—COMPARISON OF WIRE GAUGES

The sizes of wires are ordinarily expressed by an arbitrary series of numbers. Unfortunately there are several independent numbering methods, so that it is always necessary to specify the method or wire gauge used. The following table gives the numbers and diameters in decimal parts of an inch for the various wire gauges used in this country, Great Britain and the United States.

Number of wire gauge	Roebing or Washburn and Moens	Brown and Sharpe	Birmingham or Stubs	English legal standard	Old English or London
	inch	inch	inch	inch	inch
6-0	0.460			0.464	
5-0	0.430			0.432	
4-0	0.393	0.4600	0.454	0.400	0.4540
3-0	0.362	0.4096	0.425	0.372	0.4250
2-0	0.331	0.3648	0.380	0.348	0.3800
0	0.307	0.3249	0.340	0.324	0.3400
1	0.283	0.2893	0.300	0.300	0.3000
2	0.263	0.2576	0.284	0.276	0.2840
3	0.244	0.2294	0.259	0.252	0.2590
4	0.225	0.2043	0.238	0.232	0.2380
5	0.207	0.1819	0.220	0.212	0.2200
6	0.192	0.1620	0.203	0.192	0.2030
7	0.177	0.1443	0.180	0.176	0.1800
8	0.162	0.1285	0.165	0.160	0.1650
9	0.148	0.1144	0.148	0.144	0.1480
10	0.135	0.1019	0.134	0.128	0.1340
11	0.120	0.09074	0.120	0.116	0.1200
12	0.105	0.08081	0.109	0.104	0.1090
13	0.092	0.07196	0.095	0.092	0.0950
14	0.080	0.06408	0.083	0.080	0.0830
15	0.072	0.05706	0.072	0.072	0.0720
16	0.063	0.05082	0.065	0.064	0.0650
17	0.054	0.04525	0.058	0.056	0.0580
18	0.047	0.04030	0.049	0.048	0.0490
19	0.041	0.03589	0.042	0.040	0.0400
20	0.035	0.03196	0.035	0.036	0.0350
21	0.032	0.02846	0.032	0.032	0.0315
22	0.028	0.02534	0.028	0.028	0.0295
23	0.025	0.02257	0.025	0.024	0.0270
24	0.023	0.02010	0.022	0.022	0.0250
25	0.020	0.01790	0.020	0.020	0.0230
26	0.018	0.01594	0.018	0.018	0.0205
27	0.017	0.01419	0.016	0.0164	0.01875
28	0.016	0.01264	0.014	0.0148	0.01650
29	0.015	0.01125	0.013	0.0136	0.01550
30	0.014	0.01002	0.012	0.0124	0.01375
31	0.0135	0.00893	0.010	0.0116	0.01225
32	0.0130	0.00795	0.009	0.0108	0.01125
33	0.0110	0.00708	0.008	0.0100	0.01025
34	0.0100	0.00630	0.007	0.0092	0.0095
35	0.0095	0.00561	0.005	0.0084	0.0090
36	0.0090	0.00500	0.004	0.0076	0.0075
37	0.0085	0.00445	.....	0.0068	0.0065
38	0.0080	0.00397	.....	0.0060	0.0057
39	0.0075	0.00353	.....	0.0052	0.0050
40	0.0070	0.00314	.....	0.0048	0.0045

*English Legal Standard Gauge.*—Also called New British Standard Gauge, or British Imperial Standard, and very commonly used in Great Britain and this country.

*Birmingham Gauge.*—Used largely in Great Britain and some of the British Dominions for the measurement of wires of all kinds. In the United States it is applied mostly to the measurement of iron wire.

*Brown & Sharpe Gauge.*—The United States standard for wires for electrical purposes.

*Law of the Brown & Sharpe Gauge.*—The diameters of wires on the B. & S. gauge are obtained from the geometric series in which No. 0000=0.4600 inch and No. 36=0.05 inch, the nearest fourth significant figure being retained in the areas and diameters so deduced.

Let  $n$  = gauge number (0000 = — 3; 000 = — 2; 00 = — 1).

$d$  = diameter of wire in inches.

$$\text{Then } d = \frac{0.3249}{1.123^n}$$

*Sheathing core.*—The number ( $N$ ) of sheathing wires having a diameter ( $d$ ) which will cover a core having a diameter ( $D$ ) is

$$N = \pi \frac{D+d}{d}$$

TABLE 4—TENSILE STRENGTH OF BARE COPPER WIRE

Numbers, B. & S.G.	Breaking weight in pounds		Numbers, B. & S.G.	Breaking weight in pounds	
	Hard-drawn	Annealed		Hard-drawn	Annealed
0000.....	8,310	5,650	9.....	617	349
000.....	6,580	4,480	10.....	489	277
00.....	5,226	3,553	11.....	388	219
0.....	4,558	2,818	12.....	307	174
1.....	3,746	2,234	13.....	244	138
2.....	3,127	1,772	14.....	193	109
3.....	2,480	1,405	15.....	153	87
4.....	1,967	1,114	16.....	133	69
5.....	1,559	883	17.....	97	55
6.....	1,237	700	18.....	77	43
7.....	980	555	19.....	61	34
8.....	778	440	20.....	48	27

The strength of soft copper wire varies from 32,000 to 36,000 pounds per square inch, and of hard copper wire from 45,000 to 68,000 pounds per square inch, according to the degree of hardness.

The above table is calculated for 34,000 pounds for soft wire and 60,000 pounds for hard wire, except for some of the larger sizes, where the breaking weight per square inch is taken at 50,000 pounds for 0000, 000, and 00, 55,000 for 0, and 57,000 pounds for 1.

TABLE 5—PROPERTIES OF HARD-DRAWN COPPER TELEPHONE AND TELEGRAPH WIRE

Size B. & S.G.	Resistance per mile	Breaking strength	Weight per mile	Furnished in coils as follows	Approximate size E. B. B. iron wire equal to copper in conductivity.
	Ohms	Pounds	Pounds	Miles	
9.....	4.30	625	209	1.0	2
10.....	5.40	525	166	1.2	3
11.....	6.90	420	131	0.52	4
12.....	8.70	330	104	0.65	6
13.....	10.90	270	83	1.20	6½
14.....	13.70	213	66	1.50	8
15.....	17.40	170	52	2.00	9
16.....	22.10	130	41	1.20	10

Iron-wire gauge.  
(B.W.G.)

In handling this wire the greatest care should be observed to avoid kinks, bends, scratches, or cuts. Joints should be made only with copper splicing sleeves and connectors.

On account of its conductivity being about five times that of E. B. B. iron wire, and its breaking strength over three times its weight per mile, copper may be used of which the section is smaller and the weight less than an equivalent iron wire, allowing a greater number of wires to be strung on the poles.

Besides this advantage, the reduction of section materially decreases the electro-static capacity, while its non-magnetic character lessens the self-induction of the line, both of which features tend to increase the possible speed of signalling in telegraphing, and to give greater clearness of enunciation over telephone lines, especially those of great length.

TABLE 6—PROPERTIES OF BIMETALLIC WIRE<sup>1</sup>

Numbers, B. & S.G.	Diameters in mils	Weights per mile in pounds	Breaking weight in pounds	Numbers, B. & S. G.	Diameters in mils	Weights per mile in pounds	Breaking weight in pounds
0000.....	460	3,200	10,500	7.....	144	314	1 210
000.....	410	2,537	8,600	8.....	128	246	1 020
00.....	365	2,022	7,000	9.....	114	203	850
0.....	325	1,620	5,700	10.....	102	157	660
1.....	289	1,264	4,600	11.....	91	127	520
2.....	258	1 003	3,800	12.....	81	100	410
3.....	229	,797	3,200	14.....	64	63	260
4.....	204	629	2,600	16.....	51	40	160
5.....	182	490	1,790	18.....	40	25	100
6.....	162	398	1,500	.....	..	..	....

<sup>1</sup>Adapted from "Wire in Electrical Construction" by John A. Roebling's Sons Co.

This wire consists of a steel centre with a cover of copper. Its conductivity is about 65 per cent of that of pure copper. The percentage of copper and steel may vary a trifle, hence the strength and weight must be approximate.

TABLE 7—PROPERTIES OF GALVANIZED TELEPHONE AND TELEGRAPH WIRE.<sup>1</sup>

Size B. W. G.	Diameter in mils = $d$	Area in circular mils = $d^2$	Approximate weight in pounds		Approximate breaking strain in pounds			Resistance per mile (International ohms) at 68°F. or 20° C.		
			per 1000 feet	per mile	E. B. B.	B. B.	Steel	E. B. B.	B. B.	Steel
0	340	115,600	313	1,655	4,138	4,634	4,965	2.84	3.38	3.93
1	300	90,000	244	1,289	3,223	3,609	3,867	3.65	4.34	5.04
2	284	80,656	218	1,155	2,888	3,234	3,465	4.07	4.85	5.63
3	259	67,081	182	960	2,400	2,688	2,880	4.90	5.83	6.77
4	238	56,644	153	811	2,028	2,271	2,433	5.80	6.91	8.01
5	220	48,400	131	693	1,732	1,940	2,079	6.78	8.08	9.38
6	203	41,209	112	590	1,475	1,652	1,770	7.97	9.49	11.02
7	180	32,400	87	463	1,158	1,296	1,389	10.15	12.10	14.04
8	165	27,225	74	390	975	1,092	1,170	12.05	14.36	16.71
9	148	21,904	60	314	785	879	942	14.97	17.84	20.70
10	134	17,956	49	258	645	722	774	18.22	21.71	25.29
11	120	14,400	39	206	515	577	618	22.82	27.19	31.55
12	109	11,881	32	170	425	476	510	27.65	32.94	38.23
13	95	9,025	25	129	310	347	372	37.90	45.16	52.41
14	83	6,889	19	99	247	277	297	47.48	56.56	65.66
15	72	5,184	14	74	185	207	222	63.52	75.68	87.84
16	65	4,225	11	61	152	171	183	77.05	91.80	106.55

<sup>1</sup>From American Steel and Wire Co.

TABLE 8—PROPERTIES OF GALVANIZED STEEL WIRE<sup>1</sup>

Size B.W.G.	Diameter in mils	Approximate weight in pounds per 1,000 ft.	Approximate breaking strain in pounds, figured on the basis of 100,000 pounds per sq. in.	Resistance in ohms per 1,000 ft.	Size B.W.G.	Diameter in mils	Approximate weight in pounds per 1,000 ft.	Approximate breaking strain in pounds, figured on the basis of 100,000 pounds per sq. in.	Resistance in ohms per 1,000 ft.
0	340	313	9,079	0.74	9	148	60	1,720	3.92
1	300	244	7,068	0.95	10	134	49	1,410	4.79
2	284	218	6,335	1.07	11	120	39	1,131	5.98
3	259	182	5,268	1.28	12	109	32	933	7.24
4	238	153	4,449	1.52	13	95	25	709	9.93
5	220	131	3,801	1.78	14	83	19	541	12.44
6	203	112	3,237	2.09	15	72	14	407	16.64
7	180	87	2,545	2.66	16	65	11	332	20.18
8	165	74	2,138	3.16					

<sup>1</sup>From the Simplex Manual.

The strength of steel wire varies from 50,000 pounds per sq. in. to 300,000 pounds and over, depending on the kind and treatment of material.

By using the values of breaking strain shown in the above column the breaking strain figured on any other basis than 100,000 pounds per sq. in. may easily be computed. For example, with a wire with a breaking strain of 80,000 pounds per sq. in., take eight-tenths of the tabulated breaking strain for whatever size of wire the actual breaking strength is desired.

TABLE 9—PROPERTIES OF RUBBER-COVERED, LEAD-INCASED COPPER CABLES.<sup>1</sup>

Size B. & S.	Number of wires in conductor	Thickness of rubber in fractions of an inch	Thickness of lead in fractions of an inch	List number	Approx. diameter outside of lead in fractions of an inch	Approx. weight per 1000 ft., pounds
4.....	1	4-64	3-64	774	29-64	477
6.....	1	4-64	3-64	776	26-64	391
8.....	1	3-64	3-64	778	22-64	298
10.....	1	3-64	3-64	780	21-64	256
12.....	1	3-64	2-64	782	18-64	156
14.....	1	3-64	2-64	784	16-64	138
4.....	1	4-32	4-64	794	39-64	773
6.....	1	4-32	4-64	796	36-64	686
8.....	1	4-32	4-64	798	34-64	596
4.....	1	7-32	5-64	743	53-64	1,282
4.....	1	7-32	3-32	744	55-64	1,485
6.....	1	5-32	4-64	745	40-64	764
6.....	1	6-32	5-64	746	46-64	1,061
6.....	1	6-32	3-32	747	48-64	1,211
6.....	1	7-32	5-64	748	50-64	1,186
6.....	1	7-32	3-32	749	52-64	1,357
8.....	1	5-32	4-64	750	38-64	722
8.....	1	6-32	5-64	751	44-64	993
8.....	1	6-32	3-32	752	46-64	1,171
8.....	1	7-32	5-64	753	48-64	1,114
8.....	1	7-32	3-32	754	50-64	1,306

<sup>1</sup>Adapted from America Steel and Wire Co.

TABLE 10—PROPERTIES OF STANDARD WIRES FOR TELEPHONE CONSTRUCTION ON DOMINION FOREST RESERVES

Gauge Number	No. 6 B.W.G. B.B. iron	No. 9 B.W.G. B.B. iron	No. 12 B.W.G. B.B. iron	No. 14 B.W.G. B.B. iron	No. 8 B. & S.G. hard- drawn copper	No. 12 B. & S.G. hard- drawn copper	No. 14 B. & S.G. hard- drawn copper	No. 14 B. & S.G. rubber- covered copper	No. 19 B. & S.G. rubber- covered copper	No. 20 B. & S.G. stranded insulated emergency wire	No. 30 B. & S.G. hard- drawn copper
Diameter of conductor in mils..	203	148	109	83	128.490	80.808	64.084	64.084	35.390	31.961	10.025
Area in circular mils.....	41,209	21,904	11,881	6,889	16,512	6,528.6	4,108.8	4,108.8	1,288.8	1,000.00	100.00
Diameter outside insulation in inches.....									.156	.045	
Weight per mile in pounds.....	590	314	165	99	282.0	105.0	65.0	65.0	20.7	16.4	1.6
Weight per 1,000 ft. in pounds.. (Conductor with insulator).									15	3.504	
Weight per 1,000 ft. in pounds (Conductor only).	112	60	37	19	49.98	19.77	12.43	12.43	3.90	3.042	.3042
Feet per pound.....	8.9	16.6	32.2	52.6	20.040	50.659	80.580	80.580	264.136	331.13	3,311.258
Breaking stress (pounds).....	1,652	879	476	277	843	343	219	219	68.8	54.7	5.4
Resistance per mile in ohms at 68° F.....	9.49	17.84	32.94	56.56							
Resistance per 1,000 ft. in ohms at 68° F.....					.6271	1.586	2.521	2.521	8.038	10.14	103.0

## INDEX

- Acetylene lamps, 182  
Adams portable telephone, 39, 108, 110, 130, 132, 152  
Adjustment of heliograph, 174  
    of ringers, 150  
Alignment of tree lines, 68  
Alphabet, International Morse, 176  
Alternative routes, 26  
American Army heliograph, 163  
Ampere, definition of, 119  
Ardois lanterns, 15  
Armature, generator, 128  
Attachment, split tree insulator, 70  
Auger, post-hole, 38  
  
Bars, digging and tamping, 38  
Batteries, dry, types of, 39, 85, 108, 121, 125  
    inspection of, 149  
    installation of, 85  
    removal of, 88  
    renewal of, 87  
    testing of, 88  
Bell, Professor Alexander Graham, 121  
Bells, extension, altering tones of, 101  
    extension, types of, 39, 101  
    used as signals, 15  
Belts, linemen's, 37  
Books, reference, 199  
Braces, pole, 54  
Bracing of poles, 54  
Brackets, wood, 37, 50, 52, 70, 74  
    wood, attachment of, 52  
    wood, position of, 52  
    wood, specifications for, 218  
Branch lines, 82  
Bridging-bell system of telephone connection, 138.  
British Army heliograph, 162  
Brush method of treating poles, 48  
Buffalo grips, 38, 64, 158  
Butt-rot in poles, 142, 143.  
Buzzer telegraphy, 16, 113  
  
Cables, lead-encased, properties of, 225  
Calls, telephone, list of, 141  
Camp management, 3, 12  
Capacity, definition of, 131  
Carbolineum, 48  
Cell, inert, 184  
    voltaic, 127  
    voltaic, definition of, 118  
Cells, closed circuit, 125  
    open circuit, 125  
Circuit, definition of, 118  
    grounded, 28, 32, 60, 90  
    grounded, connection to metallic, 104, 106  
    grounded, definition of, 32  
    light, 32  
    metallic, 28, 32, 60, 68, 90  
    metallic, connection to grounded, 104, 136  
    metallic, definition of, 32  
    phantom, 103, 137  
    power, 32  
Clamp, Blackburn ground, 91  
    Fahnestock test, 82, 143  
Clamps, ground, types of, 41  
Climbers, linemen's, 37  
  
Code, Alphabetical Square, 178  
    American Morse, 175  
    International Morse, 15, 114, 175, 193  
    Myer, 177  
    ringing, 128, 140  
    signals, 22  
Codes, heliograph, 175  
    message, 194  
Coil, induction, definition of, 119  
    induction, use of in telephone, 125  
    telephone induction, inspection of, 149  
Coils, lavite, 98, 150  
    protection of, 98  
    repeating, 40, 98, 103, 135  
    use of, 98  
Commissary, 3, 11  
Condenser, definition of, 120  
    types of, 40  
    use of, 85, 96, 131, 132  
    use of, in vibratory signalling, 96, 132  
Conductor, definition of, 118  
Connectors, emergency, 115  
Construction materials, free grant of, 34  
Conventional signals, International Morse, 176  
Cooking outfit, list of, 198  
Co-operative telephone lines, 33  
Cord, receiver, 123, 149  
    receiver, inspection of, 149  
Costs, telephone construction, in different types, 28, 201  
    telephone construction, elements of, 201  
Cradle, Mobley wire, 46  
Creosote, specifications for, 217  
    use of, 48  
Crew, emergency line construction, 75, 76  
    telephone construction, 46, 196  
Crews, equipment of, 46  
Crossing divides, 73  
    meadows and parks, 73  
    rivers and canyons, 73  
Crossings, extra long, 78  
    foreign, 78  
    high-tension transmission lines, 78  
    Railway Board Regulations governing, 203  
    railway right of way, 78  
    road, 78  
    submarine, 80  
Cross-talk, 32, 62, 142  
    elimination of, 156  
Crossties, 71, 83  
Current, alternating, 127, 128  
    alternating, definition of, 120  
    direct, definition of, 120  
  
Dead-ending, 71, 82, 83  
Detection of forest fires, 3, 5  
Detonations, use of, as signals, 15  
"Dont's" in telephone construction, 157  
    in telephone installation, 158  
    in telephone maintenance, 159  
    in telephone operation, 158  
  
Edison, Thomas A., 125  
Electric lamps, use of, in signalling, 183  
Electro-motive force, definition of, 118  
Emergency communication equipment, use of, 9

- Emergency lines, connecting to permanent. 75  
 maintenance of, 76  
 pole setting on, 76  
 taking up wire on, 76  
 use of, 74
- Emergency telephone kits, types of, 39  
 telephone kits, use of, 108, 114
- Equipment of construction crews, 46  
 standard list of, 36
- Exchanges, private, 82
- External telephone systems, 24
- Fire boss, 18
- Fires, forest, detection of, 5  
 forest, prevention of, 3, 4  
 forest, suppression of, 7
- Fischer high-power lamp, 184
- Flags, range of, in signalling, 186  
 speed of, in signalling, 187  
 use of in forest protection, 22, 187
- Flux, 40, 219
- Forest protection force, functions of, 3
- Forest Service heliograph, 165
- Free service on Forestry Branch lines, 35
- Frequency, definition of, 120
- Fuses, types of, 39  
 use of, 88, 135
- Galvanizing, specifications for, 209
- Gauges, wire, names of, IV  
 wire, comparison of, 222
- Generator, electro-magnetic, 120  
 oiling of, 150  
 telephone magneto, 121, 127  
 telephone magneto, repairs of, 145, 147
- Ground rods, portable, 41  
 portable types of, 41
- Grounds, 32, 90  
 multiple, 92  
 precautions in locating, 91  
 temporary, 116
- Guy rods, 38
- Guys, anchor, 55  
 pole, 54  
 rock, 57  
 tree, 56
- Hammers, claw, 41
- Hand set, Adams, 39, 108, 110, 1130, 132, 152
- Haven clamps, 38
- Haze, effect on range of heliograph, 175
- Heliograph, 160  
 adjustment of, 174  
 American Army, 160, 163, 173  
 British Army, 160, 162, 173  
 Forest Service, 160  
 Godwin, 160, 165, 169  
 mirrors, 169  
 parts of, 169  
 range of, 161  
 screens, 170  
 sighting-rods, 170  
 speed of, 161  
 stations, 21, 160, 165  
 tripods, 170  
 use of in forest protection, 21, 160  
 use of at lookout stations, 165  
 use of on patrol, 169
- Heliographs on towers, 168
- Heliographing by artificial light, 181  
 by moonlight, 181  
 with one mirror, 171  
 with two mirrors, 172
- High-tension lines, interference from, 42, 60, 62, 78, 104  
 protection from, 89, 94, 134
- Hitch, barrel, use of, 76
- Holes for telephone poles, digging of, 50
- Howlers, 40, 96, 132  
 use of in vibratory signalling, 96
- Induction, electro-magnetic, definition of, 119  
 electro-static, definition of, 120
- Insulator, definition of, 118
- Insulators, glass, specifications for, 213  
 glass, types of, 37, 52  
 glass, use of, 27, 74  
 split tree, attachment of, 70, 73  
 split tree, specifications for, 214  
 split tree, types of, 37  
 split tree, use of, 29, 30, 42, 44  
 strain, 41, 71
- Internal telephone systems, 25, 36
- Joints, emergency wire, 76  
 insulated wire, 93  
 Western Union, 65
- Knives equipment, list of, 198
- Knives, electricians', 40
- Lanterns, acetylene, for signalling, 182  
 electric, for signalling, 183, 184  
 Fischer high-power, 184  
 signalling, 182
- Lightning arresters, types of, 39  
 arresters, use of 88, 133  
 danger of, in construction, 60
- Linemen, 29  
 "Listening in," 131, 132
- Location of telephone lines, factors influencing, 42
- Lookout men, permanent, in forest protection, 17, 18  
 stations, 7, 21, 26, 36, 73, 165, 185, 187  
 station telephones, 94  
 stations, heliograph at, 165
- Magnet, definition of, 118
- Magnets, use of, in generators, 128  
 use of, in ringers, 129
- Magneto telephone, description of, 117
- Materials, emergency line, 74  
 line, 59, 69  
 standard, list of, 36
- McIntyre sleeves, 38, 65
- Message codes, 194
- Microphone, carbon, 123
- Mil, definition of, 121
- Mobley wire-cradle, 43 46
- Monkey-wrench, 41
- Mounting-box, protector, specifications for, 219
- Nails, 37  
 milonite, 40, 94
- Numerals, International Morse, 176
- Ohm, definition of, 119
- Ohm's Law, 119
- Open-tank treatment of poles, 48
- Operators, heliograph, training of, 180
- Pack-frames, Klondike, 45, 46  
 Mobley, 43, 46
- Packmaster, 10, 18, 19
- Party lines, definition of, 137
- Patrol, railway speeder, portable telephone for, 109
- Patrolmen in forest protection, 18, 21, 25.
- Permanent forces, direction of, 9
- Pigeons, carrier, 14
- Pike-poles, 38
- Pipes, grounding on, 91
- Plans, fire, 9  
 telephone system, 23, 25
- Plates, ground, types of, 41, 91
- Pliers, linemen's, 37, 40



- Pole lines, definition of, 27
- Poles, cedar, specifications for, 215
- dimensions of, 47
  - lasting qualities of various species of, 47
  - number per carload, 221
  - preservative treatment of, 47
  - seasoning of, 47
  - self-supporting, 57
  - setting of, 52
  - shortened, re-setting of, 145
  - weights of various lengths and tops, 221.
- Pole-steps, 41, 52
- Preservative treatment of poles, 47
- Prevention of forest fires, 3, 4
- Private telephone lines, 33
- Protection standards in relation to telephone lines, 35
- Protectors, in fully exposed stations, 89
- in partially exposed stations, 89
  - location of, 89
  - repair of, 147
  - telephone, types of, 38
  - telephone, types of, 39
- Provisions, list of, 198
- Public roads, use of for telephone lines, 44
- Punctuation, International Morse, 176
- Quartermaster, 11, 12, 18
- Railways, crossing of, 78
- Rake, in pole-setting, 50, 52
- Receiver, head, 38
- telephone, 121, 131, 152
  - telephone, repairs of, 146, 149
- Reconnaissance in fire protection, 3, 11
- Reel, emergency wire, 38, 75
- pay-out, 38, 60
- Relay stations, 26
- Repeating coils, 40
- Reserves, in forest protection forces, 9
- Resistance, definition of, 119
- Right of way, clearing of, 44
- securing of, 42
- Ringers, telephone, 121, 128
- telephone, Ohm resistance of, 23, 129, 139
  - telephone, repairs of, 148, 150, 152
- Roads, crossing of, 78
- Rods, ground, 41, 91
- ground, inspection of, 147
  - ground, portable, 116
  - lightning, 39, 52
- Roof ridge of poles, position of, 53
- Rules, operating, 140
- Sag allowance, 29, 62, 70
- distribution of, on pole lines, 63
- Screw-drivers, 40
- Scouts and scouting in forest protection, 3, 18, 19
- Semaphore, fixed, 191
- signalling with flags, 188, 191
  - signalling with fixed, 191
  - signals, 14
- Series system of telephone connection, 137
- Shovels, types of, 38
- Signalling, buzzer or vibratory, 113
- Signals, audible, 14, 15, 22
- chronosemic, 14
  - code, 14
  - colour, 15
  - danger, 22, 195
  - electro-telegraphic, 15
  - flash, 15
  - shape, 15
  - shot, 196
  - visual, 14
  - whistle, 196
- Smoke, effect on range of heliograph, 175
- "Smoke chaser," 7, 9, 18, 19, 25
- Solder, 40
- Soldering copper, 40
- methods and materials, 219
- Spacing of poles, 50
- Splicing clamps, 37
- wire, 65
- Spools, emergency wire, 74, 75, 76
- emergency wire, specification for, 217
- Spoons, digging, 38
- Standards, D. F. B. construction, 60
- Staples, Blake insulated, 40
- Static electricity, 156
- Stations, heliograph, selection of, 173
- signalling, 173, 188
- Strand, galvanized steel, 41, 71
- Strategy, fire suppression, 3, 12
- Stubs, as pole reinforcements, 143
- Submarine telephone lines, 80
- Supervision, fire-fighting, 3, 8
- Supervisor, forest, 18, 19, 23, 34, 35
- Supplies, pole-line, 197
- station, 197
  - tree-line, 197
- Supports, in forest protection forces, 9
- Suppression, fire, 3, 7
- forces, maintenance and direction of, 9
  - forces, mobilization of, 9
  - staff officers, 10
- Survey of route for telephone line, 42
- Surveys, forest, use of signals on, 187
- Switchboards, 101, 135
- Switches, 131, 135, 142
- repair of, 147
- Switch-hook, 121, 130
- inspection of, 147
- Tactics, fire suppression, 12
- Tamping around poles, 50, 54
- Tape, electricians', 40
- Telegraph, 20
- lines, 32, 78
  - simultaneous operation with telephone, 106
  - wireless, 14, 16
- Telephone, desk set, 38
- instruments, types of, 38
  - lookout-station sets, 94
  - magneto, description of, 117
  - portable, 25, 30, 107, 108
  - portable, Adams, 39, 108, 110, 130, 132, 152
  - portable, Forest Service Special, 39, 108, 114, 130, 152
  - simultaneous operation with telegraph, 106
  - wall set, 38, 85
  - wireless, 14, 16
- Tension, definition of, 120
- Tentage for telephone crew, 198
- Test sets, 107
- stations, 26, 142
- Ties, regular, 63
- "figure 8," 63, 64, 73, 78
- Timber conditions, influence on telephone construction of, 30
- Tools, emergency line, 74, 198
- linemen's, 37, 46
  - line-stringing, 38, 46, 197
  - pole-setters, 38, 46, 197
- Torch, soldering, 40
- Tree lines contrasted with pole lines, 28
- cost of, 28, 201
  - definition of, 27
  - development of methods, 29
- Transmitter, telephone, 121, 123
- telephone, inspection of, 147
  - White (or solid back), 123

- Transportation in forest protection, 10
- Transposition, 32, 62, 68
- Trimmers, tree, 41
- Tripods, as line supports, 57
  - heliograph, 169, 170
- Trouble, telephone, guide to clearing, 153
- Trumpet blasts, used as signals, 15
- Tubes, porcelain, 40, 92
- Tying-in wire, 63
- Vibratory signalling, 96, 113
- Volt, definition of, 118
- Voltmeter test-stations, 142
- Whistle blasts, used as signals, 15
- Wigwag codes, 191
  - signalling with flags, 189
  - signals, 14
- Wire, bimetallic, properties of, 224
  - copper, 28, 33, 37, 60, 61, 81, 83, 92
  - copper, properties of, 223
  - copper, specifications for, 211
  - copper, tensile strength of, 223
  - D. F. B. standard, properties of, 226
  - emergency, 27, 37, 74
  - emergency, specifications for, 211.
  - galvanized-iron, 23, 28, 33, 36, 59, 69
  - galvanized-iron properties of, 224
  - galvanized-iron, specifications for, 210
  - galvanized steel, properties of, 225
  - ground, 93
  - man-packing of, 46
  - rubber-covered, specifications for, 212
  - stringing of, 29, 60, 70
- Wiring, inside building, 93
  - outside building, 92







**THIS BOOK IS DUE ON THE LAST DATE  
STAMPED BELOW**

**AN INITIAL FINE OF 25 CENTS**

**WILL BE ASSESSED FOR FAILURE TO RETURN  
THIS BOOK ON THE DATE DUE. THE PENALTY  
WILL INCREASE TO 50 CENTS ON THE FOURTH  
DAY AND TO \$1.00 ON THE SEVENTH DAY  
OVERDUE.**

SEP 9 1941 M

LD 21-100m-7,'40(6936s)

982320 SD411  
M5

THE UNIVERSITY OF CALIFORNIA LIBRARY

