

THE MICROSCOPE

SIMON HENRY GAGE

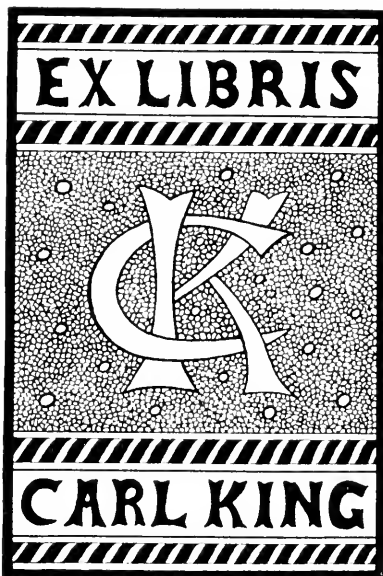

Marine Biological Laboratory Library
Woods Hole, Massachusetts



Gift of Bostwick H. Ketchum - 1976



The MICROSCOPE

AN INTRODUCTION TO MICROSCOPIC
METHODS AND TO HISTOLOGY

BY SIMON HENRY GAGE

PROFESSOR OF HISTOLOGY AND EMBRYOLOGY, EMERITUS
IN CORNELL UNIVERSITY

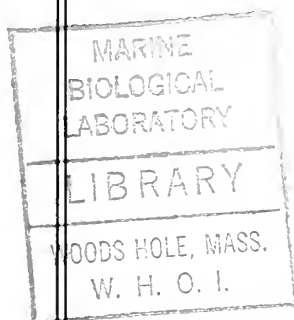
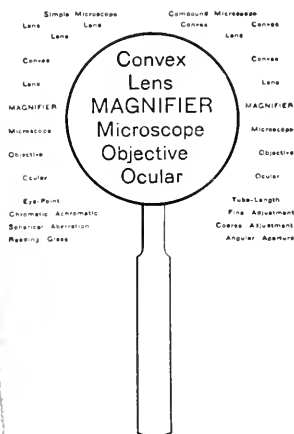

TWELFTH EDITION

Rewritten and Illustrated by over 250 Text Figures

THE COMSTOCK PUBLISHING COMPANY

1917

Copyright, 1908
BY SIMON HENRY GAGE
All Rights Reserved

Copyright, 1917
BY SIMON HENRY GAGE
All Rights Reserved



TO
SUSANNA PHELPS GAGE

WHO AS A STUDENT RECEIVED HELP AND INSPIRATION FROM THE EARLIEST EDITIONS OF THIS WORK, AND WHO AIDED IN EVERY WAY POSSIBLE BY DRAWING, INDEX-MAKING AND LITERARY CRITICISM IN IMPROVING THE LATER EDITIONS; AND WHO NOW HAS ENTERED INTO THE POSSIBILITIES OF ETERNITY

THIS TWELFTH EDITION IS DEDICATED

P R E F A C E

IN revising and rewriting this book now for the twelfth time, the aim has been as for all previous editions, to give the student the benefit of the fundamental things which have been worked out in microscopy. The opportunities given by the freedom from teaching have rendered it possible to make this revision more thorough than could be done in any previous edition.

Progress in all that pertains to microscopy has been marked during the last ten years. Any one can see this clearly by comparing the catalogues of manufacturers sent out ten years ago with those sent out at the present time.

Nothing fundamentally new has appeared, but there have been great advances in making practical and usable many processes and much apparatus for which the basic knowledge has existed for a considerable time. Of course there are some principles and manipulations which a person must become master of if he is to work successfully with the microscope. These have been treated mainly as in the past. Of the new things nothing has been considered in the book which has not been personally tested and found to be workable and helpful.

Among the most important means recently made available, especially for students of biology, are the following:

(1) The single objective binocular for all powers of the microscope from the lowest to the highest.

(2) The dark-field illuminator for all powers, especially the highest powers with which the finest details in living structures can be seen with marvelous clearness. This makes it possible to compare the living cell with the fixed and stained one.

(3) The perfection of apparatus with which the powerful electric lights recently produced have become available for demonstrations and for drawing with the projection microscope.

(4) The perfection of photographic light filters and the production of dry plates sensitive to the whole spectrum makes it possible to get good photographs of any microscopic specimen, and indeed of any specimen.

(5) From the numbers who are affected, and the extent of its application, perhaps the greatest improvement of all has been the production of a glass filter which, when used with a gas filled mazda lamp, gives a light of true daylight quality and of sufficient intensity for all powers of the microscope.

In preparing this edition some parts of the previous edition have been omitted. For example, the pages on micro-chemistry and metallography have been left

out because the *Micro-Chemistry* of Dr. E. M. Chamot, which has recently appeared treats these and indeed all matters pertaining to the chemico-physical side of microscopy in an adequate manner.

As a closing word it may be said that even an elementary book like this depends for its production upon many helps. The work of others must be looked for in a great library; special knowledge in allied departments must be utilized through the help of colleagues; apparatus and ideas can only be put in graphic form by the deft hand of the artist; and perhaps most important of all is the advice and criticism of the friend. All of these helps the author has had in abundance, and he feels grateful to each helper.

SIMON HENRY GAGE

CORNELL UNIVERSITY

February 22, 1917

CONTENTS

	PAGES	FIG.
Introduction	1- 5	1- 3
CHAPTER I	6-35	4-29
The Microscope and Its Parts: Simple and compound microscopes; Visual angle and apparent size of objects; Lenses; Construction of images; Experiments with the simple microscope; Compound microscope and objectives and oculars; Experiments with the compound microscope.		
CHAPTER II	36-76	30-50
Practical Work with the Parts of the Microscope: Focusing experiments; Working distance; Lighting with daylight; Lighting with artificial light; Artificial daylight with daylight glass; Condensers or illuminators, and experiments with them; Dark-ground illumination with low and with high powers.		
CHAPTER III	77-106	51-64
Adjustable and Immersion Objectives; Binocular Microscopes; Care of the Microscope and of the Eyes: Adjustable and immersion objectives and experiments; Refraction and color images; Binocular microscopes for low and for high powers; Care of the microscope and of the eyes; Testing the microscope; Laboratory and school microscopes; Markers and mechanical stages; Standard sizes of the Royal Microscopical Society.		
CHAPTER IV	107-126	65-74
Interpretation of Appearances Under the Microscope: Determination whether an object is under the microscope or the appearance is due to dust, etc., on the ocular, etc.; Relative position of objects; Air bubbles and oil globules; Velocity under the microscope; Pedesis or Brownian movement; Inversion of the microscopic image.		

	PAGES	FIG.
CHAPTER V	127-159	75-98
<p>Magnification and Micrometry with the Microscope: Need of magnification; Visual angle and the microscope; Magnification and virtual and real images; Distance at which to determine magnification; Ways to determine magnification; Camera lucida, ocular micrometers.</p>		
CHAPTER VI	160-205	99-125
<p>Drawing and Class Demonstrations with the Microscope and Projection Microscope: Drawing microscopic objects with the camera lucida or with the projection microscope; Determining the magnification at which the drawing is made; Avoidance of inversion; Use of photographic prints to aid in making drawings; drawings and their lettering for publication; Class demonstrations.</p>		
CHAPTER VII	206-245	126-143
<p>Photography with the Microscope and with Projection Apparatus: Photographs of embryos, etc., with a vertical camera; Photographing with a microscope; Lighting and experiments in photography; Scale at which photographs are made; Daylight glass for photographing with the microscope; Enlarging photographs; Color screens and color photography.</p>		
CHAPTER VIII	246-269	144-150
<p>The Spectroscope and Polariscopes and Their Use with the Microscope: Visible and invisible radiation; Kinds of spectra; Micro-spectroscope and its use; Absorption bands; Micro-polariscopes and its use.</p>		
CHAPTER IX	270-311	151-184
<p>Some Optical Principles Involved in the Construction and Use of the Microscope: Reflection, refraction, dispersion, diffraction; Lenses and images; Spherical and chromatic aberration and their correction; Angular and numerical aperture; Diffracted light in microscopy; Magnification of the individual parts of the microscope; Parfocal oculars and objectives.</p>		

	PAGES	FIG.
CHAPTER X	312-367	185-215

Materials of Microscopy; Mounting and Storing Microscopic Specimens: Slides and cover-glasses, their size and preparation; Mounting microscopic objects in the various ways; Isolation of tissue elements; Collection and study of microscopic animals and plants; Labeling, cataloguing and storing microscopic preparations; Cabinets, lockers and trays for specimens; Reagents for microscopic work, with formulae for their preparation.

CHAPTER XI	368-423	216-247
----------------------	---------	---------

Fixing, Imbedding, Sectioning, Staining; Serial Sections and Models: Fixation and preservation of organs, tissues, embryos and small animals for microscopic study; Microtomes and section knives for microscopic sections; Free-hand sectioning. Paraffin method of sectioning; Collodion method of sectioning; Staining and mounting; Serial sectioning and its advantages; Serial sections of embryos and small animals; Orientation for sectioning and mounting the series; Planes for sectioning, — transverse, saggital and frontal; Modeling with wax, and with blotting paper. Drawings for models.

CHAPTER XII	424-443	248-252
-----------------------	---------	---------

Brief History of Lenses and Microscopes: Lenses and their use for spectacles, for projection apparatus; Simple microscopes; Dutch compound microscope; Keplerian compound microscope; Binocular microscopes; Microscopes where two or more observers can look at the same object at the same time; Mirrors and condensers; Achromatization; Immersion and homogeneous immersion objectives; Projection microscope; Drawing magnified images by the aid of the camera lucida and projection apparatus.

Bibliography	445-452	
Index	453-472	

THE MICROSCOPE AND MICROSCOPICAL METHODS

INTRODUCTION

IN dealing with the possibilities and use of any method of investigation, any machine or piece of scientific apparatus, the writer or teacher will naturally proceed as seems to him best from his personal experience, from his general theory of education, and from his conception of the style and method of presentation which will render his book most acceptable to his possible readers.

As stated in the preface to the sixth edition, this book had its origin in the laboratory, and its purpose was, and still is, to give the guidance by which those unfamiliar with the microscope and the methods of work with it can gain an intelligent understanding of the instrument, its limitations, and its possibilities for aiding one to arrive at truth.

In working out the plan the following landmarks have been kept constantly in sight:

(1) To most minds, and certainly to those having any grade of originality, there is a great satisfaction in understanding principles; and it is only when the principles are firmly grasped that there is complete mastery of instruments, and full certainty and facility in using them. The same is true of the methods of preparing objects for microscopic study, and the interpretation of their appearances when seen under the microscope.

Much good work can be and has been done by the rule of thumb method, in which there is no real understanding of the underlying reason for any of the operations; the worker simply knows that good results follow a certain course of action. Probably most of the work of the world is done by rule of thumb. But the originators of the knowledge making rule of thumb possible must have some compre-

hension of principles, and the reasons for what is done. For creative work, then, knowledge of principles is indispensable.

(2) Need of abundant practical work to go with the theoretical part has been shown by all human experience. In all the crafts and in all the fine arts mastery comes only with almost endless effort and repetition, the most common example being the attainment of facility in music. Hence in this work there have been introduced many practical exercises so that the worker might gain the deftness needed. It is also a part of human experience that in successfully going through the manipulations necessary to demonstrate principles

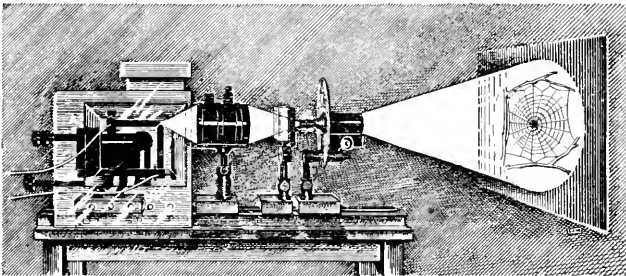

FIG. 1. PROJECTION MICROSCOPE WITH ENLARGED REAL IMAGE ON THE SCREEN.

and methods, the principles and methods themselves become more real. That is, comprehension of principles aids in the certainty with which work can be done, and conversely the doing of the work helps to increase the grasp on the principles.

After observing the work of students in my own and in other laboratories the conclusion was reached and expressed in the third edition of this book (1891) that "simply reading a work on the microscope, and looking a few times into an instrument completely adjusted by another, is of very little value in giving real knowledge. In order that the knowledge shall be made alive, it must be a part of the student's experience by actual experiments carried out by the student himself."

Beale, in his work on the microscope, expresses it thus: "The num-

ber of original workers emanating from our schools will vary as practical work is favored or discouraged. It is certain that they who are most fully conversant with elementary details, and most clever at demonstration, will be most successful in the consideration of the higher and more abstruse problems, and will feel a real love for their work which no mere superficial inquirer will experience. It is only by being thoroughly grounded in first principles, and well practised in mechanical operations, that any one can hope to achieve real success in the higher branches of scientific inquiry, or to detect the fallacy of certain so-called experiments."

And Hon. J. D. Cox, skilled alike in the arts of war, statesmanship, and science, in his notable address upon Systematic Instruction in the Microscope at the University, before the American Microscopical Society, in 1893, says: "I wish to urge the desirability of a somewhat extensive course of technical training in regard to the microscope. . . . Any one who desires to devote himself seriously to investigation with the microscope will find great advantage, as it seems to me, in devoting some time to the study of the instrument itself in all its parts, and the history of their development." The study of this whole address is urged upon the person interested in the just appreciation of the different parts of the microscope and their successful employment or improvement.

Sir A. E. Wright, in his book "Principles of Microscopy," says this: "Every one who has to use the microscope must decide for himself the question as to whether he will do so in accordance with a system of rule of thumb, or whether he will seek to supersede this by a system of reasoned action based upon a study of his instrument and a consideration of the scientific prin-

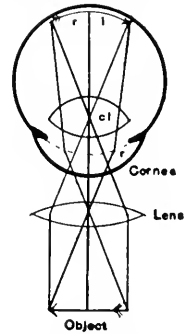

FIG. 2. A SIMPLE MICROSCOPE HELPING THE EYE TO FORM A RETINAL IMAGE OF A NEAR OBJECT.

Object The object to be seen by the eye.

Lens The double convex lens acting as a magnifier or simple microscope to aid the eye in seeing a near object.

Cornea The cornea of the eye.

r The single refracting surface in the schematic eye.

cl The crystalline lens of the eye, also the center of the refracting surfaces or the nodal point of the eye where the secondary axial rays cross.

ri Retinal image; it is inverted.

ciples of microscopical technique. The present text-book [his "Principles of Microscopy"] has no message to those who are content to follow a system of rule of thumb, and to eke this out by blind trial and error. It addresses itself to those who are dissatisfied with the results thus obtained and who desire to master the scientific principles of microscopy, even at the price of some intellectual effort."

From the observation of ten generations of students and their subsequent career I am confirmed in the belief that for attainment in study with the microscope, as in all other human endeavor, a person must pay for all he gets.

(3) In considering the microscope, it may be looked at as a machine composed of glass and brass complete in itself, or it may be considered as an artificial aid to the eye, like a spectacle. When complete in itself it is properly called a projection microscope,

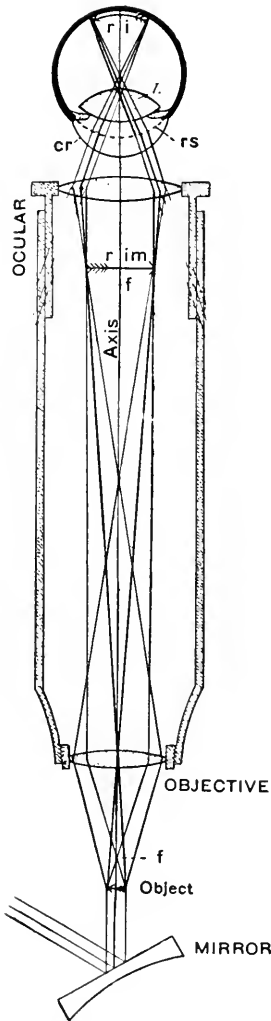

FIG. 3. A COMPOUND MICROSCOPE HELPING THE EYE TO FORM A RETINAL IMAGE OF A NEAR OBJECT.

Mirror The plane and concave mirror to reflect light through the object.

Object The small object to be seen by the eye.

Objective The objective of the compound microscope to form a real image of the small object.

Axis The principal optic axis of the microscope.

f Principal focus of the ocular and of the objective.

r im The real image formed by the objective.

Ocular The double convex lens enabling the eye to see the real image formed by the objective.

cr The cornea of the eye.

rs The refracting surface of the schematic eye.

L The crystalline lens of the eye.

r i The retinal image; it is erect with reference to the object, but inverted as compared with the real image.

for it produces an image wholly independent of the eye of the observer. This image may be fixed on a photographic plate or used as a basis for a drawing (fig. 1). On the other hand, when used as a microscope in the ordinary way, the eye of the observer is an integral part of the optical combination, just as integral a part as the objective or the ocular (fig. 2, 3). This being the case the optical perfection of the eye is as influencing on the final retinal image as the perfection of the other optical parts.

And finally, quoting again from the preface of the third edition, "In considering the real greatness of the microscope and the truly splendid service it has rendered, the fact has not been lost sight of that the microscope is, after all, only an aid to the eye of the observer, only a means of getting a larger image on the retina than would be possible without it, but the appreciation of this retinal image, whether it is made with or without the aid of a microscope, must always depend upon the character and training of the seeing and appreciating brain behind the eye. The microscope simply aids the eye in furnishing raw material, so to speak, for the brain to work upon."

CHAPTER I

THE MICROSCOPE AND ITS PARTS

§ 1. Apparatus and material for Chapter I.

1. A simple microscope (§ 3, 14, fig. 4, 6).
2. A compound microscope with nose-piece (§ 4, fig. 25-28).
3. Eye-shade (fig. 33).
4. Achromatic (§ 26), apochromatic (§ 28), dry (§ 22), immersion (§ 23-25), unadjustable (§ 30), adjustable objectives (§ 31).
5. Huygenian or negative (§ 38), positive (§ 39), compensation oculars (§ 40).
6. Stage micrometer (§ 48).
7. Homogeneous immersion liquid (§ 25).
8. Mounted letters or figures (§ 50).
9. Ground-glass and lens paper (§ 50).
10. Black card with pin-hole (§ 7, fig. 7).
11. Dissecting spectacles (§ 145).

§ 2. As the word itself indicates, a microscope is an instrument with which one can see small things (§ 2a).

The microscope makes small things or minute details of larger things visible in two distinct ways, both ways being dependent on an increase of the visual angle (§ 6, 226-227, fig. 75-76).

(1) The first way of increasing the visual angle and thus making small things or details visible is by means of one or more lenses used as a kind of spectacle by which the eye is enabled to form a sharp image on the retina when optically so close to the object that without the artificial aid a sharp image on the retina could not be produced (fig. 2, 3, 6).

(2) The second way of increasing the visual angle under which small things or details are viewed is by means of a projection microscope, which, wholly independent of the eye, produces a sharp, greatly enlarged image of the object upon a white surface. The eye then looks at this image as though it were the object itself and of that size (fig. 1, § 312).

The fundamental difference in the two forms of microscope is that

in the first only a retinal image is formed, while in the second, a screen image and from that a retinal image.

In this book the first form of microscope is mainly considered except in Ch. VI and VII, where the projection microscope is much used.

§ 2a. The word Microscope is from two Greek words: *μικρός* — mikros, small, and *σκοπεῖν* — skopein, to see. The word was compounded and given a Latin form by Giovanni Faber of the Academy of the Lincei, as shown by a letter of his to Cesi, President of the Lyceum, dated April 13, 1625. Faber says: "As I also mention his [Galileo's] new oghiale to look at small things and call it Microscopium." Jour. Royal Microscopical Society, 1889. p. 578; Carpenter-Dallinger, p. 125.

SIMPLE AND COMPOUND MICROSCOPES

§ 3. A simple microscope or magnifier is a lens or a combination of lenses to use with the eye, and with it an enlarged, erect image is seen, that is, the enlarged image has all its parts in the same position as in the object itself (fig. 4), and but one image is formed, and that is formed upon the retina.

§ 4. A compound microscope is one in which a lens, or combination of lenses, called an objective, forms a real image, and this real image is looked at, as if it were an object, by the eye and a magnifier or simple microscope known as an ocular. The image seen has the object and its parts inverted. In the compound microscope two images are formed, one by the objective independent of the eye, and the other on the retina by the action of the eye-lens of the ocular and the cornea and crystalline lens of the eye (fig. 3).

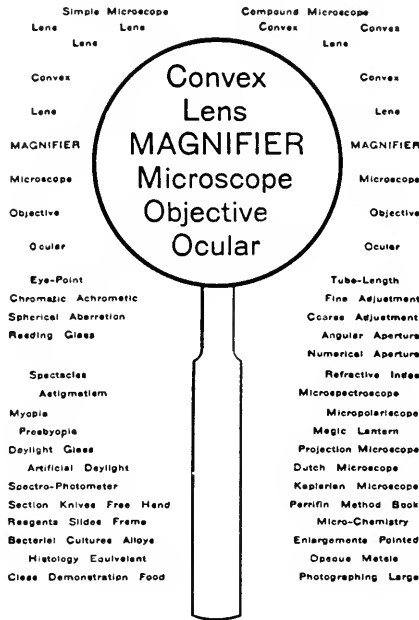

FIG. 4. FINE PRINT SEEN BY THE UNAIDED EYE AND THROUGH A MAGNIFIER.

§ 5. **Virtual images.**—In all diagrammatic drawings showing the microscope when looking directly into it, an enlarged, imaginary

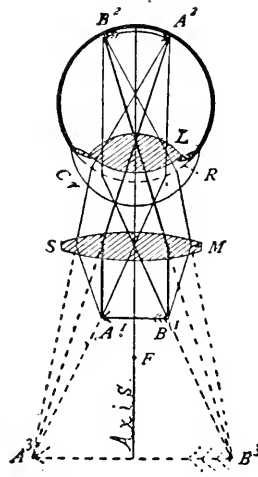
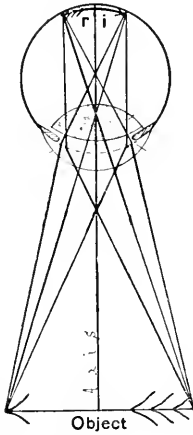

FIG. 5-6. VISION BY THE UNAIDED EYE AND BY THE AID OF A SIMPLE MICROSCOPE.

FIG. 5. UNAIDED EYE VISION. AXIS, THE PRINCIPAL OPTIC AXIS OF THE EYE EXTENDED TO THE OBJECT.

Object The object to be seen; it is at a distance of 250 millimeters from the eye.

r i The retinal image; it is inverted.

FIG. 6. VISION BY THE AID OF A SIMPLE MICROSCOPE. AXIS, PRINCIPAL OPTIC AXIS OF THE MICROSCOPE AND OF THE EYE.

A¹ B¹ The object within the principal focus (*F*) of the lens.

S M A double convex lens acting as a simple microscope.

Cr The cornea of the eye.

R Single refracting surface of the schematic eye.

L The crystalline lens of the eye.

B² A² The retinal image; it is inverted.

A³ B³ The virtual image projected into the field of vision at 250 millimeters; it is erect, and the appearance is exactly as if the virtual image were an object as in fig. 4, and no lens were present.

object is shown out in space. This is frequently called a virtual image. If there were no microscope and an object of that size were in front of the observer, he would get the same appearance, for a retinal image of the same size would be produced as is produced by the magnifying

glass helping the eye (fig. 5-6). In the projection microscope there is an actual or real enlarged image on a screen which the observer looks at as if it were a large object (fig. 1). If one keeps in mind that virtual images are purely imaginary, and that real images are produced by actual rays of light, it will help to avoid confusion and wrong interpretations. In every case where an object is seen, light rays must pass from the object to the eye, and these rays entering the eye must form an image on the retina. It is the retinal image which furnishes the brain the stimulus for vision.

APPARENT SIZE OF OBJECTS

Whether one is using a microscope or not, the apparent size of any object seen depends upon the visual angle. Practically the entire purpose subserved by the microscope is that it enables the eye to see objects under a greater visual angle than would be possible without the artificial aid.

§ 6. **Visual angle.** — This is the angle made by the border rays of light from the object to the retina, and crossing at the nodal point or optical center of the eye (fig. 75-76).

As the visual angle depends upon the distance the object is separated from the eye, any means by which the object can be brought closer to the eye will result in giving a larger apparent size to the object, or in magnifying it. The lenses of the microscope used with the eye enable it to get very close to the object and thus increase the visual angle, and depending on the closeness, finer and finer details of the object are separated, for they subtend an angle of one minute or more (see § 226), and the object as a whole has a much greater apparent size. (For further discussion see Ch. V.)

§ 7. **Pin-hole card.** — Use a piece of paper about the size of a library card. If the slip is black or of a dark color it makes the experiment a little easier than when white paper is used. Make a hole in this with a needle (fig. 7). If now one holds the slip up close to the eye and gets the hole in the optic axis, the eye can see brilliantly lighted objects very clearly. If, to start with, the object is off about 1 meter, quite an extent of it can be seen, and it will appear small. Now go up closer and closer, and still the object is clearly seen, and

constantly appearing larger. The closer one gets the smaller is the visible field, but the larger will the parts seem to be. If the hole is quite small, one can get the object within 4 or 5 cm. of the eye and still see the image clearly, and see details which could not be seen at a greater distance.

As shown in the figures of the visual angle (fig. 76), the closer the eye gets to the object the greater will be the visual angle, hence details



FIG. 7. PIN-HOLE CARD FOR VIEWING NEAR OBJECTS.

are shown which did not appear at a greater distance. One of the best methods of trying this experiment is to use for object a small mark made with ink or a glass pencil on a window or on a milky or transparent lamp shade. Then there will be plenty of light. The physiological explanation of the power to see clearly through the pinhole at a distance of 5 cm., when, if the eye looks directly at the object, it should be about 25 cm. from the eye, is, that with the pin-hole the beam is so narrow that it affects so narrow a circle on the retina that the appearance is like a good focus. If one takes away the card, the beam gets very wide and the eye has only a blurred impression, the diffusion circles are so large.

§ 7a. In case one loses his spectacles or has the accommodation paralyzed by atropin for testing the eyes, it is possible to read fairly well with the perforated card if the print is in a brilliant light. The field which can be seen at one time is very small, so one must move the print or the head almost constantly.

LENSES

The usual and most effective means for increasing the visual angle when examining small objects is by the use of lenses, singly or in combination.

§ 8. *Lens.* — A lens means a mass of transparent glass or other substance with one plane and one curved, or with two curved sur-

faces. Natural transparent minerals may also be given a lenticular form, e.g. fluorite, quartz, etc.

The lens is usually a segment of a sphere or of two spheres (fig. 8). In dealing with lenses mention must frequently be made of the optical center of the lens, the principal axis, secondary axis, and the principal focus. These are illustrated in fig. 8, 11-12, and are briefly:

(1) *Optical center.* — The point in or near a lens through which, if rays pass, they will suffer no angular deviation, and the emerging ray will be parallel to the incident ray (fig. 8 *c.l*).

(2) *Principal axis.* — The axis passing through the centers of curvature of the two spheres whose surfaces bound the lens (fig. 8).

(3) *Secondary axis.* — Any axis oblique to the principal axis, but passing through the optical center of the lens (fig. 11-12). A ray along a secondary axis undergoes no angular deviation, although it may suffer displacement as a ray in traversing a piece of plane glass (fig. 51).

(4) *Principal focus.* — The point where rays of light, parallel to the principal axis, cross after traversing the lens (fig. 10). Every lens has two principal foci, one on each side (fig. 10).

With concave lenses the foci are virtual (fig. 9).

§ 9. **Refraction.** — By this is meant the change in direction of light in passing from one transparent medium into another. The possibility of the production of images by lenses depends upon refraction.

The amount of refraction depends upon two things:

(1) The difference in density of the two media. The greater the difference, the greater the amount of bending of the light in passing from one medium to another.

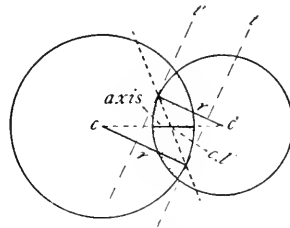

FIG. 8. LENS WITH OUTLINES OF THE TWO SPHERES OF WHICH IT IS SEGMENTS.

Axis The principal optic axis, the line joining the two centers of curvature (*c c'*).

c c' Centers of curvature, — centers of the two spheres from which the lens is derived.

r r' Parallel radii.

t t' Tangents at the terminal points of the radii.

c.l Center of the lens, — point where the line joining the radii at the tangential points crosses the principal axis.

(2) The obliquity with which the light strikes the second medium. The greater this obliquity the greater the bending of the light, in accordance with the law of sines. (For further discussion see Ch. IX.)

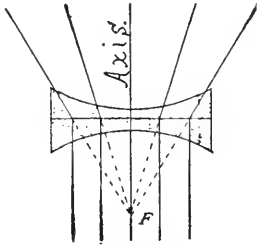

FIG. 9. CONCAVE LENS SHOWING VIRTUAL FOCUS (F).

angular deviation for rays but there will be a certain amount of displacement, although the emerging ray will remain parallel to the entering or incident ray (fig. 51).

For the construction of images it is necessary to know the position of the principal focus and the optical center of the lens.

§ 10a. Geometrical construction of images. — It should be remembered in making the drawings for the geometrical construction of images that there are two fundamental laws which must always be obeyed.

(1) Light rays extend in straight lines in a transparent medium of uniform density, and whenever the direction is to be changed the light must meet a

§ 10. Geometrical construction of images. — In this book the lenses shown are thick, but the course of the rays, for simplicity, is shown to be as if the lenses were infinitely thin, that is, they show all the bending at one plane (the refracting plane, fig. 11-12). In reality there is one refraction at the incident or entering surface and one at the emerging surface. With thick lenses like those figured, there will be no

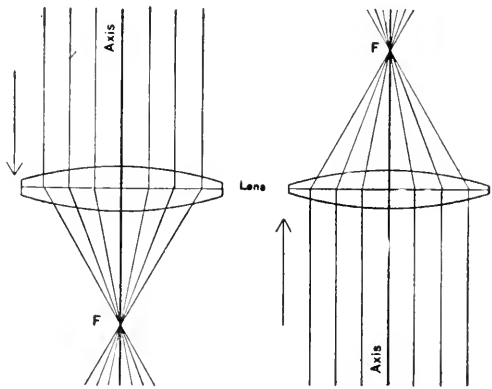

FIG. 10. LENS WITH A PRINCIPAL FOCUS ON EACH SIDE.

Axis The principal optic axis.

F The principal focus, — the point on the axis at which rays parallel with the principal axis cross.

The arrows indicate the direction of the light.

different refracting medium, or a reflecting surface. That is, the direction of a ray of light may be changed by using a mirror, or by putting in its path a transparent medium of greater or less refracting power.

(2) The second law is, that objects are always seen in the direction in which the light reaches the eye, regardless of the actual position of the object. This will be abundantly illustrated in the chapter on drawing; and every one knows that objects seen in a mirror are not where they appear to be in the mirror.

§ 11. Construction of real images.

—(1) The object must be situated at a greater or less distance beyond the principal focal point (fig. 11).

(2) From some point in the object, draw a line to the refracting plane of the lens (§ 10) parallel to the principal axis, and from this crossing point at the refracting plane of the lens to the focus of the lens, and continue the line indefinitely (fig. 11).

(3) From the same point of the object as in (2), draw a secondary axis through the optical center of the lens and extend it indefinitely (fig. 11).

The image of the point in the object from which the two lines were drawn will be located at the point where the two extended lines cross above the lens (fig. 11).

The image of all the other points of the object may be determined by drawing lines from them exactly as just described.

If the image is known one can find the object by reversing the process just described.

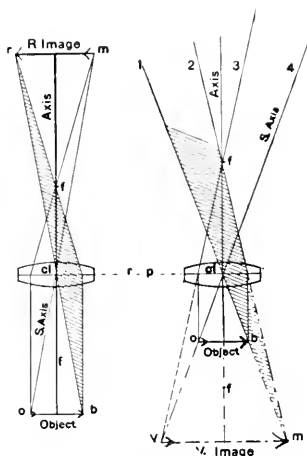

FIG. 11-12. GEOMETRICAL CONSTRUCTION OF REAL AND OF VIRTUAL IMAGES.

Object, Object The object of which an image is to be formed.

Axis, Axis The principal optic axis extended above and below the lens to the object and image.

S. Axis, S. Axis Secondary axis passing from the object through the center of the lens.

f, f, f, f The principal foci of the two lenses.

r-p The plane of refraction (the ideal plane at which all the refraction is made to occur in diagrams of thick lenses).

R. Image Real image.

V. Image Virtual image indicated by broken lines as it has no real existence.

o b, r m Rays of light indicated by lines passing from the extremities of the object to the extremities of the real image, which is inverted.

o b, v m Lines representing rays of light from the object passing in a diverging manner above the lens, and extended by broken lines below the lens to form a virtual image at their crossing points, *v m*.

§ 12. **Construction of virtual images.** — (1) For these the object must be somewhere between the principal focus and the lens.

(2) From some point in the object draw a line to the refracting plane of the lens, parallel to the principal axis, and from this point through the principal focus, and continue it indefinitely.

(3) From the same point of the object as in (2) draw a secondary axis through the optical center of the lens and extend it indefinitely.

The two lines will not cross above the lens, but if they are extended below the lens (fig. 12) they will cross, and the crossing point locates the image. But as there are no light rays extending in this direction the image is imaginary or virtual. That is, it looks as if the rays reaching the eye originated from the point where the rays would cross if extended backward.

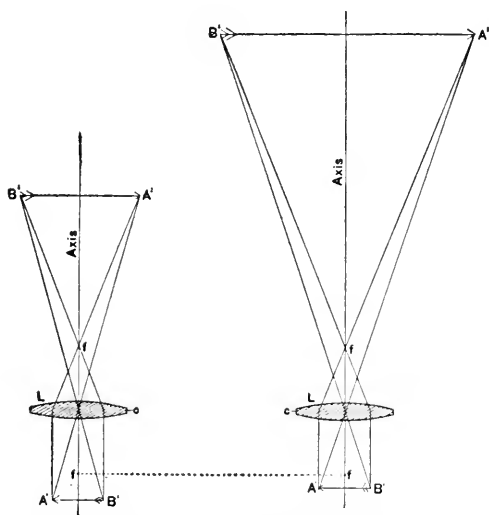

FIG. 13-14. REAL IMAGE WITH THE OBJECT FAR FROM AND NEAR TO THE PRINCIPAL FOCUS.

Axis, Axis The principal optic axis extended above and below the lenses.

f, f, f, f The principal foci of the lenses.

L c, L c The same lens with the object farther from and nearer to its principal focus.

A B, B' A' The object and its inverted image when the object is far from the principal focus.

A B, B' A' The object and larger inverted real image when the object is near the principal focus.

§ 13. **Relative position of object and image.** — The general law is that the nearer the object to the principal focus the farther away is the image; and conversely, the nearer the image is to the principal focus the farther from it must be the object. And from the law of similar triangles, the size of the image is to the size of the object as the distance of the image from the center of the lens is to the distance

of the object from that center. In a word, the nearer the object to the focus, the farther away the image from that point, and the greater the relative size of the image. This is equally true of real and of virtual images (fig. 13-16).

EXPERIMENTS WITH THE SIMPLE MICROSCOPE

§ 14. For a simple microscope use a reading glass, or any form of simple microscope such as the tripod magnifier (fig. 17, 18). Hold the magnifier over a printed page and look through the magnifier. The letters and words will appear as they do with the naked eye, but larger (fig. 4).

In order to get the sharpest image it will be necessary to raise and lower the magnifier until the best position is found. This mutual arrangement of magnifier and object is called focusing, or getting into focus.

§ 15. Size of the field. — With any given magnifier, the size of the field, that is the area which can be seen, is larger with the eye near the magnifier.

Demonstrate this by holding the eye 10 to 20 cm. above the tripod magnifier and noting the number of letters or words which can be seen. Then lower the head till the eye is only 2 to 5 cm. from the magnifier, and again note the number of letters or words which can be seen. It will be necessary to focus the magnifier for each position of the eye.

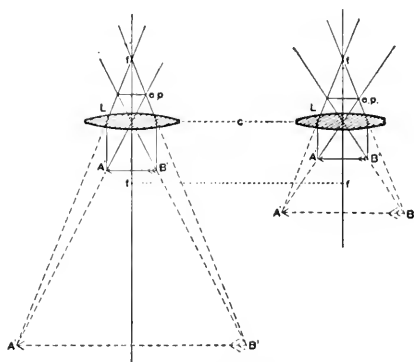

FIG. 15-16. VIRTUAL IMAGE WITH THE OBJECT NEAR TO AND FAR FROM THE PRINCIPAL FOCUS.

f, f, f The principal foci on the axis above and below the lens.

Lc, Lc The same lens to show the difference in size of the virtual image with the object near to and far from the principal focus.

ep The eye-point.

A B, A' B' The object and its erect virtual image.

§ 16. **Mounting of simple microscopes.** — Magnifiers are arranged in mountings to be held in the hand; for example, reading glasses

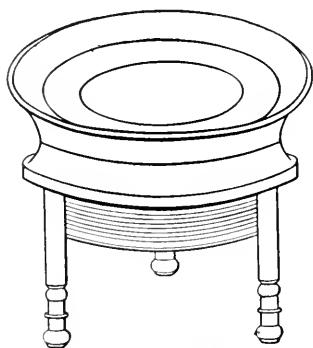

FIG. 17. TRIPOD MAGNIFIER.

and pocket magnifiers. The tripod magnifier (fig. 17) may be held in the hand or supported by its legs over the object to be seen. Sometimes there is a special support with arrangements for focusing as well as holding the magnifier in any desired position (fig. 19). This arrangement is especially desirable when magnifiers are used for dissection. For the purposes of dissection and examining objects under a small magnification, binocular arrangements like spectacles are very

convenient, as one can move the head and bring the object into view at will (§ 145).

COMPOUND MICROSCOPE

§ 17. This, as shown in fig. 3 and 20, and explained above, aids the eye in obtaining an enlarged retinal image by two steps, viz. the formation of a large real image by the objective and a retinal image of this real image by means of the microscope ocular, and the cornea and crystalline lens of the eye, the ocular acting in general like a simple microscope (§ 3).

For holding the objective and ocular and focusing the microscope, there are a number of mechanical arrangements necessary. For illuminating the object there is usually a mirror and often a condenser. It is customary and convenient to divide the parts of a compound microscope into two groups: (1) the optical parts, and (2) the mechanical parts (fig. 25).

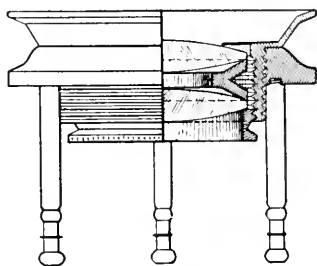

FIG. 18. TRIPOD MAGNIFIER WITH A SECTION REMOVED TO SHOW THE TWO COMPONENT, CONVEX LENSES AND INTERVENING DIAPHRAGM.

OPTICAL PARTS OF A COMPOUND MICROSCOPE

§ 18. **Objective.** — This is a lens, or combination of lenses, which, under the proper conditions, produces an enlarged, inverted image of some object (fig. 11, 20).

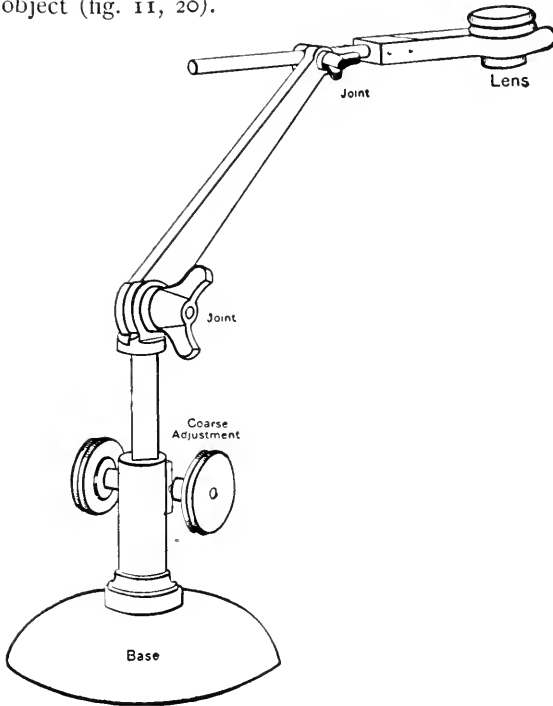

FIG. 19. ADJUSTABLE LENS HOLDER WITH JOINTS.

Base The heavy base supporting the lens holder.

Coarse Adjustment The rack and pinion for focusing the lens.

Joint, Joint The joints enabling one to put the lens in any desired position.

Lens This is held in a spring fork or in a socket.

Practically all microscopic objectives are composed of one or of several combinations of lenses. The purpose of combining the lenses is to produce an image as nearly as possible like the object itself, by doing away with certain defects or aberrations inherent in simple lenses (fig. 21).

Mirror The plane and concave mirror to reflect the light up through the object to the microscope and to the eye.

Object The object to be seen.

f The principal focus of the

Objective The lens serving to project.

Axis The principal optic axis of the eye.

rim The real image formed above the principal focus (*f*)

Ocular The convex lens real image.

cr The cornea of the

rs The refracting sur-

L The crystalline lens

ri The retinal image; with the real image formed as compared with the

Virtual Image The projected into the field of 250 millimeters.

This image is inverted as compared with the object, but the real image formed

The microscope enables small object as if it were enlarged to the size of the virtual image at a distance of 250 millimeters from the eye.

The microscope enables small object as if it were enlarged to the size of the virtual image at a distance of 250 millimeters from the eye.

The microscope enables small object as if it were enlarged to the size of the virtual image at a distance of 250 millimeters from the eye.

The microscope enables small object as if it were enlarged to the size of the virtual image at a distance of 250 millimeters from the eye.

The microscope enables small object as if it were enlarged to the size of the virtual image at a distance of 250 millimeters from the eye.

The microscope enables small object as if it were enlarged to the size of the virtual image at a distance of 250 millimeters from the eye.

The microscope enables small object as if it were enlarged to the size of the virtual image at a distance of 250 millimeters from the eye.

The microscope enables small object as if it were enlarged to the size of the virtual image at a distance of 250 millimeters from the eye.

The microscope enables small object as if it were enlarged to the size of the virtual image at a distance of 250 millimeters from the eye.

The microscope enables small object as if it were enlarged to the size of the virtual image at a distance of 250 millimeters from the eye.

The microscope enables small object as if it were enlarged to the size of the virtual image at a distance of 250 millimeters from the eye.

The microscope enables small object as if it were enlarged to the size of the virtual image at a distance of 250 millimeters from the eye.

The microscope enables small object as if it were enlarged to the size of the virtual image at a distance of 250 millimeters from the eye.

The microscope enables small object as if it were enlarged to the size of the virtual image at a distance of 250 millimeters from the eye.

The microscope enables small object as if it were enlarged to the size of the virtual image at a distance of 250 millimeters from the eye.

The microscope enables small object as if it were enlarged to the size of the virtual image at a distance of 250 millimeters from the eye.

The microscope enables small object as if it were enlarged to the size of the virtual image at a distance of 250 millimeters from the eye.

The microscope enables small object as if it were enlarged to the size of the virtual image at a distance of 250 millimeters from the eye.

The microscope enables small object as if it were enlarged to the size of the virtual image at a distance of 250 millimeters from the eye.

The microscope enables small object as if it were enlarged to the size of the virtual image at a distance of 250 millimeters from the eye.

The microscope enables small object as if it were enlarged to the size of the virtual image at a distance of 250 millimeters from the eye.

The microscope enables small object as if it were enlarged to the size of the virtual image at a distance of 250 millimeters from the eye.

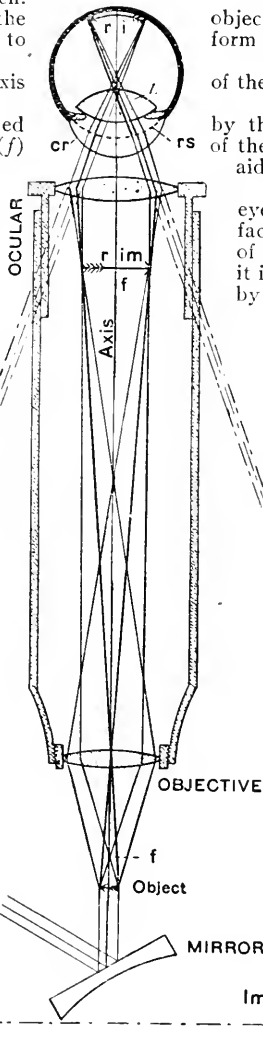

objective.

form a real image of the ob-

ject.

of the microscope and of the

by the objective; it is just

of the ocular.

aiding the eye to see the

eye.

face of the schematic eye.

of the eye.

it is inverted as compared

by the objective, but erect

object.

retinal image pro-

vision at a distance of

verted as compared

erect as compared with

by the objective (*rim*).

the eye to look at the

were enlarged to the

tual image and

of 250 millimeters

of 250 millimeters

of 250 millimeters

of 250 millimeters

of 250 millimeters

of 250 millimeters

of 250 millimeters

of 250 millimeters

of 250 millimeters

of 250 millimeters

of 250 millimeters

of 250 millimeters

of 250 millimeters

of 250 millimeters

of 250 millimeters

of 250 millimeters

of 250 millimeters

of 250 millimeters

of 250 millimeters

of 250 millimeters

of 250 millimeters

of 250 millimeters

of 250 millimeters

of 250 millimeters

of 250 millimeters

of 250 millimeters

of 250 millimeters

of 250 millimeters

of 250 millimeters

of 250 millimeters

of 250 millimeters

of 250 millimeters

of 250 millimeters

of 250 millimeters

of 250 millimeters

of 250 millimeters

of 250 millimeters

of 250 millimeters

of 250 millimeters

FIG. 20. COMPOUND MICROSCOPE WITH PROJECTED VIRTUAL IMAGE.

OBJECTIVES AND THEIR DESIGNATION

§ 19. **Equivalent focus.** — In America, England, and now also on the Continent, objectives are designated by their equivalent focal length. This length is given either in inches (usually contracted to in.) or in millimeters (mm.). Thus: An objective designated $\frac{1}{2}$ in. or 2 mm. indicates that the objective produces a real image of the same size as is produced by a simple converging lens whose principal focal distance is $\frac{1}{2}$ inch or 2 millimeters (fig. 10). An objective marked 3 in. or 75 mm. produces approximately the same sized real image as a simple converging lens of 3 inches or 75 millimeters focal length.

As in microscopic work the object is always very close to the principal focal plane, the magnification of the image is very approximately the number obtained by dividing the image distance (fig. 84) by the equivalent focus of the objective. It follows from this that the less the focal distance of the objective, the greater is the size of the real image, as the image distance remains constant. For example, if the image distance is 250 mm., the real image of a 2 mm. objective is $2\frac{5}{2}^0$, or 125 times longer than the object: of a 5 mm. objective it is $2\frac{5}{5}^0 = 50$ times longer, etc., i.e., in these examples the magnification is 125 and 50 respectively (§ 19a).

§ 19a. **Initial magnification.** — In addition to the equivalent focus, some modern objectives are marked with their so-called *initial magnification*. By this is meant the magnifying power of the objective alone at some standard image distance. For example, the initial magnification of the Zeiss 2 mm. apochromatic objective is given as 125. That is, the image distance is taken as 250 mm. ($2\frac{5}{2}^0 = 125$). With some opticians (Spencer Lens Co., Bausch & Lomb Optical Co.) the initial magnification is that number which multiplied by the power of the ocular gives the final magnification of the entire microscope (tube-length 160 mm., projection distance of the virtual image by the eye, 250 mm.). If one multiplies the initial magnification by the equivalent focus in a list of these objectives, the image distance of the real image of the objective will be found to vary from 160 to 180 mm. That is, the image distance divided by the equivalent focus would give the initial magnification listed, only by varying the image distance.

§ 20. **Numbering or lettering objectives.** — Instead of designating objectives by their equivalent focus, many Continental opticians use letters or figures for this purpose; in most cases, however, the equivalent focus is also given. With this method the smaller the

number, or the earlier in the alphabet the letter, the lower is the power of the objective. This method is entirely arbitrary and does

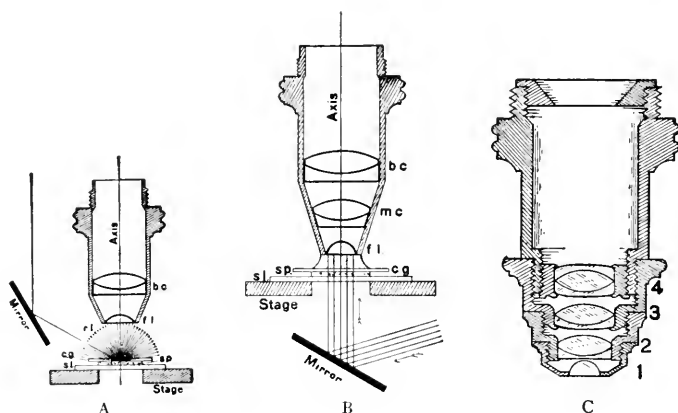

FIG. 21 A. LOW OBJECTIVE IN SECTION.

Axis The principal optic axis of the objective.

fl The front lens of the objective.

bc The back combination composed of a concave and a convex lens.

Stage The stage of the microscope in section.

Mirror The mirror is above the stage in this case and reflects light down upon the object.

rl Reflected light from the object.

sl The glass slide.

sp The specimen on the slide.

cg Cover-glass over the specimen.

FIG. 21 B. HIGH POWER OBJECTIVE IN SECTION.

Axis The principal optic axis of the objective.

bc Back combination of a double convex and a plano-concave lens.

mc Middle lens combination.

fl Front lens of the objective.

cg, sp, sl The cover-glass, specimen, and slide.

Stage The stage of the microscope in section.

Mirror The mirror reflecting parallel rays up through the specimen.

FIG. 21 C. HIGH-POWER OBJECTIVE OF FOUR COMBINATIONS.

1 The front lens.

2, 3, 4 The three combinations of lenses, the back combination (4) composed of three lenses.

not, like the one above, give direct information concerning the objective.

§ 21. **Names applied to parts of objectives.** — As objectives have usually two or more combinations of lenses (fig. 21 A-C) it is convenient to have a name for each combination.

(1) Front combination. This is the part of the objective nearest the object.

(2) Back combination. The combination of lenses farthest above the object, and, hence, nearest the ocular.

(3) Intermediate or middle combination. The lenses between the front and back lenses. Sometimes there are two or more intermediate combinations (fig. 21 C).

KINDS OF OBJECTIVES

Depending on their construction or manner of use, objectives have received special designations or names.

§ 22. **Dry objectives.** — These are objectives in which air is between the objective and the object or cover-glass (fig. 34).

§ 23. **Immersion objectives.** — With these there is some liquid between the front of the objective and the object or the cover-glass (fig. 21 B). Immersion objectives are usually designated by the name of the liquid used.

§ 24. **Water immersion objectives.** — With these there is water between the cover-glass or the object and the front lens.

§ 25. **Homogeneous or oil immersion objectives.** — The immersion liquid in such objectives has the same refractive index (see Ch. IX) as glass, hence the light suffers no refraction in passing from the glass slide and cover-glass into the immersing liquid, and from that into the objective. As the liquid used with these objectives is nearly always thickened cedar-wood oil, they are more frequently called oil immersion than homogeneous immersion objectives.

§ 26. **Achromatic objectives.** — These are objectives in which the image is practically free from rainbow colors. They are composed of one or more combinations of convex and of concave lenses (see Ch. IX, under chromatic aberration). All good microscope objectives are achromatic.

§ 27. **Aplanatic objectives, etc.** — These are objectives or other pieces of optical apparatus (oculars, illuminators, etc.) in which the

spherical distortion is wholly or nearly eliminated, and the curvatures are so made that the central and marginal parts of the objective focus rays at the same point or level. Such pieces of apparatus are usually achromatic also.

§ 28. **Apochromatic objectives.** — By this is meant objectives in which by means of special forms of glass and a natural mineral (Calcium fluorid, Fluorite, Fluor-spar) the color and the spherical corrections have been made especially perfect, that is, rays of three spectral colors are combined into one focus instead of rays of two colors as with the ordinary achromatic objectives.

§ 29. Semi-apochromatic, parachromatic, pantachromatic objectives are trade names for those containing one or more lenses of the new forms of glass and are said to approximate more closely with the apochromatic than with the older achromatic objectives.

§ 30. **Non-adjustable or unadjustable objectives.** — Objectives in which the lenses or lens systems are permanently fixed in their mounting so that their relative position always remains the same. Lower power objectives and those with homogeneous immersion are mostly non-adjustable. For beginners and those unskilled in manipulating adjustable objectives (§ 31), non-adjustable ones are more satisfactory, as the optician has put the lenses in such a position that the most satisfactory results may be obtained when the proper thickness of cover-glass and tube-length are employed (Ch. IX).

§ 31. **Adjustable objectives.** — An adjustable objective is one in which the distance between the systems of lenses (usually the front and the back systems) may be changed by the observer at pleasure. The object of this adjustment is to correct or compensate for the displacement of the rays of light produced by the mounting medium and the cover-glass after the rays have left the object. It is also to compensate for variations in tube-length (§ 134). As the displacement of the rays by the cover-glass is the most constant and important, these objectives are usually designated as having cover-glass adjustment or correction. (See also practical work with adjustable objectives, § 134).

§ 32. **Variable objective.** — This is a low power objective of 36 to 26 mm. equivalent focus, depending upon the position of the com-

binations. By means of a screw collar the combinations may be separated or brought closer together. If they are separated the power is diminished; and if brought closer together the power is increased.

§ 33. **Illuminating or vertical illuminating objectives.** — These are designed for the study of opaque objects with good reflecting surfaces, like the rulings on metal bars and broken or polished and etched surfaces of metals employed in micro-metallography. The light enters the side of the tube or objective and is reflected vertically downward through the objective and thereby is concentrated upon the object. The object reflects part of the light back into the microscope, thus enabling one to see a clear image.

§ 34. **Low and high objectives.** — A low objective is one that magnifies relatively little, and a high objective is one that magnifies the real image greatly (fig. 21 B,C). By looking at the equivalent focus of an objective one can, of course, tell very precisely concerning its magnification (§ 19, 19a), but it is also very convenient to judge something of the power by the general looks. As a rough statement it may be said that a high power usually appears more elaborate than a low power. The front lens is usually smaller, and the whole mounting is usually longer. Conversely, low objectives are usually shorter and the front lens larger than with high powers.

OCULARS AND THEIR DESIGNATION

§ 35. An ocular or eye-piece for the microscope consists of one or more converging lenses or lens systems next the eye. Its main purpose is to act with the eye as a magnifier of the real image formed by the objective (fig. 20). Incidentally the ocular also serves to correct some of the defects of the objective (see Ch. IX).

Oculars may be divided into groups according to their construction or action.

§ 36. **Positive oculars.** — These have the real image of the objective formed below all the lenses of the ocular (fig. 22 A,B).

§ 37. **Negative oculars.** — In these the real image formed by the objective is between the lenses (fig. 23, 24).

In a negative ocular the lower or field lens acts with the objective

to form the real image, while the upper or eye lens acts with the eye to form a retinal image of the real image (fig. 23, 24).

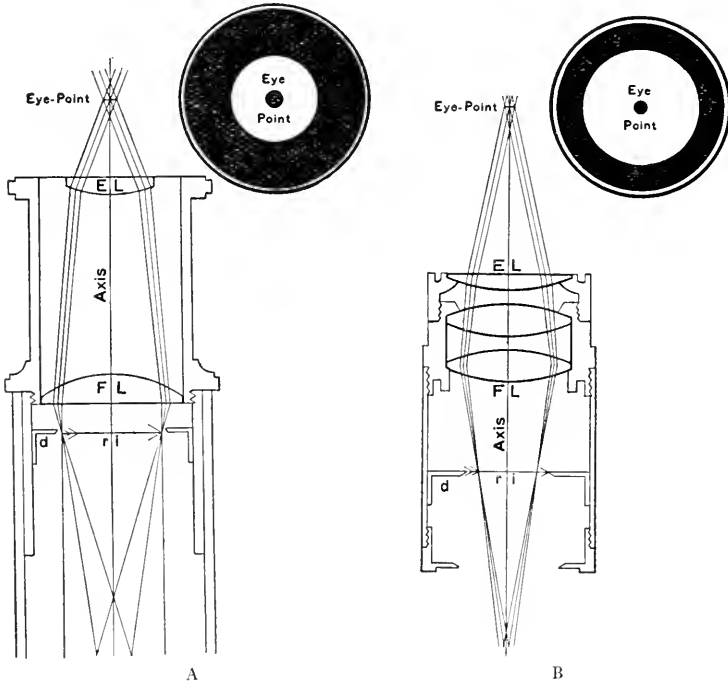

FIG. 22 A. RAMSDEN OCULAR WITH THE REAL IMAGE BELOW AND THE EYE-POINT ABOVE.

Axis The principal optic axis of the ocular.
d, ri The ocular diaphragm and the real image formed by the objective below the lenses.

FL The field-lens of the ocular.

EL The eye-lens.

Eye-point The eye-point in section and in face view, looking at the upper end of the ocular.

FIG. 22 B. POSITIVE COMPENSATION OCULAR.

Axis The principal optic axis of the ocular.

d, ri The ocular diaphragm and the real image.

FL The field combination composed of three lenses.

EL The eye-lens.

Eye-point The eye-point in section and as seen by looking down upon the end of the ocular.

Positive and negative oculars can be readily distinguished by inspection, as the ocular diaphragm, at the level where the real image of the objective is formed, is between the lenses of the negative type, and below all the ocular lenses of the positive type (fig. 22, 23).

§ 38. **Huygenian ocular.** — A negative ocular devised by the Dutch astronomer Huygens. This is the most common ocular used on the microscope, and consists of a plano-convex field-lens and a similar, but higher power, eye-lens, the convex surfaces of both facing downward (fig. 23, 24). Theoretically the focal length of the field-lens is about three times that of the eye-lens, but in practice the ratio varies with the power, being 1 to 1.5 or 1 to 2 with low powers and nearer 1 to 3 with the high powers. The ocular diaphragm is placed approximately at the focus of the eye-lens.

§ 39. **Ramsden ocular.** — This is a positive ocular composed of two plano-convex lenses with the convex faces turned toward each other, and so arranged that the real image is formed below both lenses (fig. 22 A), not between them, as with the Huygenian ocular. In the best modern forms of Ramsden ocular the simple lenses are not used, but achromatic combinations (see Ch. IX for further discussion). The Ramsden form is often used for ocular micrometers (§ 243).

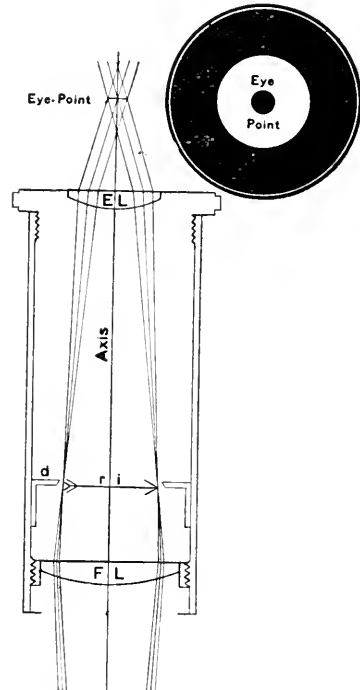

FIG. 23. LOW-POWER HUYGENIAN OCULAR IN SECTION.

Axis The principal optic axis of the ocular.

FL Field-lens of the ocular.

d, ri Diaphragm and real image between the ocular lenses.

EL Eye-lens of the ocular.

Eye-Point The eye-point seen in section and by looking down upon the end of the ocular.

§ 40. **Compensating oculars.** — These are either positive or negative oculars chromatically overcorrected to compensate for and correct the residual color defects in the extra-axial portion of the visual field due to the non-achromatic front lens of the objective (fig. 22 B). They are regularly used with apochromatic objectives, and may be used to advantage with high-angled objectives of the ordinary type (see further in Ch. IX).

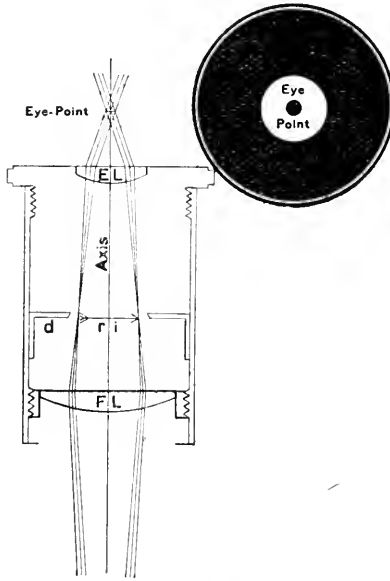

FIG. 24. HIGH-POWER HUYGENIAN OCULAR.

Axis The principal optic axis.

FL Field-lens.

d, ri The diaphragm and real image between the ocular lenses.

EL Eye-lens.

Eye-point The eye-point in section and face view, looking down upon the upper end of the ocular.

POWER OF OCULARS

As oculars of all kinds are made in different magnifying powers, there is needed some form of designation. Many different ways of designation have been used, as lettering, numbering, giving the equivalent focus, etc.

§ 41. **Lettering or numbering.** — This is a purely arbitrary form of designation, but practically all of the opticians adopted the rule that the lower power should be designated by the first letter of the alphabet, or No. 1, and that the succeeding letters or numerals should

indicate progressive increase in power, although there was no general agreement as to the exact amount of that increase. Occasionally one still meets with oculars lettered A, B, C, D, or numbered 1, 2, 3, 4, etc. In any given make of ocular one has simply to remember that the earlier the letter or the smaller the number, the lower is the power.

§ 42. **Equivalent focus.** — Some opticians give the equivalent focus of the ocular as with objectives (§ 19); then the user can select with the same certainty as with objectives.

§ 43. **Magnification of oculars.** — The most recent method is to mark upon the ocular the increase it gives in magnification to the objective (5x, 10x, etc.). If, for example, the real image formed by the objective is 10 times larger than the object, and this real image is magnified 5 times by the ocular, the total magnification of the microscope is 50. If the ocular magnified 10, then the final image would be 100 times the size of the object, etc. By this method the part done by the ocular can be seen by inspecting the ocular. (For the method of determining the magnification of the ocular, etc., see Ch. IX.)

The power of the ocular is also indicated by the appearance. A long ocular in which the space between the eye-lens and field-lens is considerable, and the eye-lens is relatively large is usually a low power (fig. 23). If the ocular is short and the eye-lens relatively small, the ocular has a relatively high power (fig. 24).

For the mechanical parts of the microscope see fig. 25, and § 164-166).

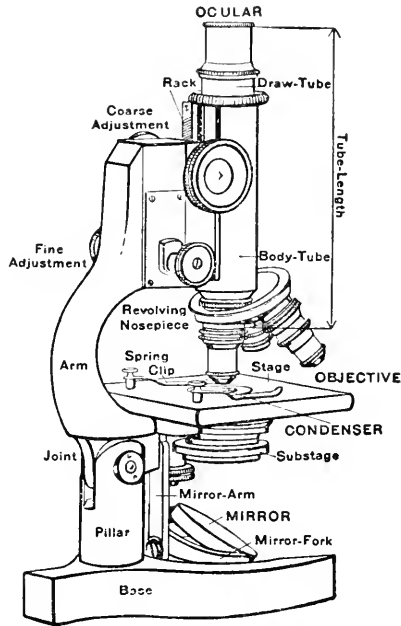

FIG. 25. LABORATORY COMPOUND MICROSCOPE WITH THE PARTS NAMED.

Mirror, Condenser, Objective, Ocular

Tube-length This is the space between the insertion of the objective below and that of the ocular above. It is most commonly 160 millimeters.

Mechanical parts These are named in order from the base.

EXPERIMENTS WITH THE COMPOUND MICROSCOPE

§ 44. **Putting an objective in position and removing it.** — Elevate the tube of the microscope by means of the coarse adjustment (fig.

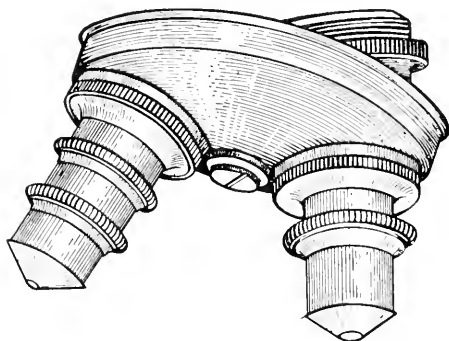

FIG. 26. DOUBLE NOSE-PIECE WITH THE OBJECTIVES IN PLACE.

25) so that there may be plenty of room between its front or lower end and the stage. Grasp the objective lightly near its lower end with two fingers of the left hand, and hold it against the nut at the lower end of the tube or the revolving nose-piece (fig. 26-28). With two fingers of the right hand take hold of the milled ring near the back or upper end of the objective and screw it into the tube of the microscope or nose-piece. Reverse this operation for removing the objective. By following this method the danger of dropping the objective will be avoided.

§ 45. **Putting an ocular in position and removing it.** — Elevate the body of the microscope with the coarse adjustment so that the objective will be 2 cm. or more from the object, grasp the ocular by the milled ring next the eyelens (fig. 25) and the coarse adjustment or the tube of the microscope and gently force the ocular into posi-

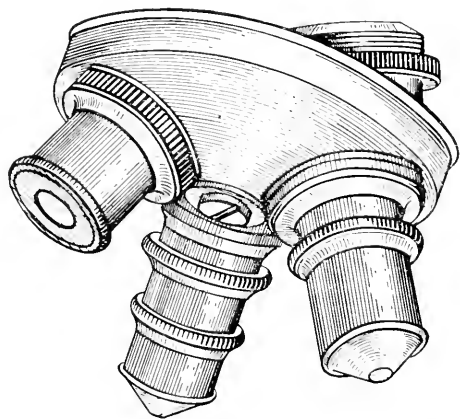

FIG. 27. TRIPLE NOSE-PIECE WITH THE THREE OBJECTIVES IN POSITION.

tion. In removing the ocular, reverse the operation. If the above precautions are not taken, and the oculars fit snugly, there is danger in inserting them of forcing the tube of the microscope downward and the objective upon the object.

§ 46. Putting an object under the microscope. — This is so placing an object under the simple microscope, or on the stage of the compound microscope, that it will be in the field of view when the microscope is in focus (§ 47, 69, fig. 63).

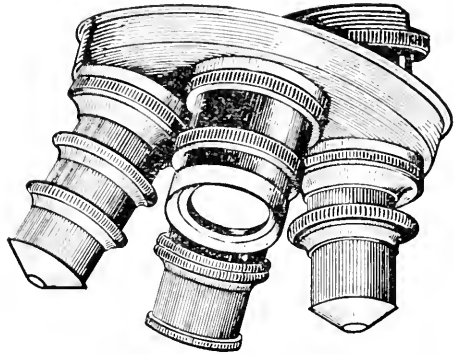

FIG. 28. QUADRUPLE NOSE-PIECE WITH THE FOUR OBJECTIVES IN PLACE.

With low powers, it is not difficult to get an object under the microscope. The difficulty increases, however, with the power of the microscope and the smallness of the object. It is usually necessary to move the object in various directions while looking into the microscope, in order to get it into the field. Time is usually saved by getting the object in the center of the field with a low objective before putting the high objective in position. This is greatly facilitated by using a nose-piece, or revolver (fig. 26-28).

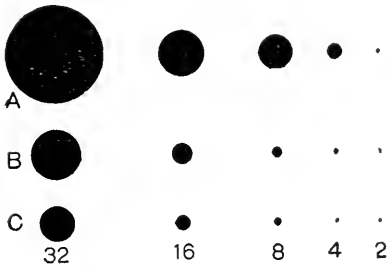

FIG. 29. MICROSCOPIC FIELD WITH AND WITHOUT OCULARS.

A The field of the 2, 4, 8, 16 and 32 mm. objectives without an ocular.

B Field of the same objectives with a 5x ocular.

C Field of the same objectives with a 10x ocular.

32, 16, 8, 4, 2 Equivalent focus of the different objectives whose fields are shown.

§ 47. Field or field of view of a microscope. — This is the area visible through a microscope when it is in focus. When properly lighted and there is no

object under the microscope, the field appears as a disc of light. When examining an object it appears within the light circle, and by moving the object, if it is of sufficient size, different parts are brought successively into the field of view.

In general, the greater the magnification of the entire microscope, whether the magnification is produced mainly by the objective, the ocular, or by increasing the tube-length, or by a combination of all three (§ 235), the smaller is the field.

The size of the field is also dependent, in part, without regard to magnification, upon the size of the opening in the ocular diaphragm. Some oculars, as the orthoscopic and periscopic, are so constructed as to eliminate the ocular diaphragm, and in consequence, although this is not the sole cause, the field is considerably increased.

§ 48, **Measuring the size of the field.** — Use a stage micrometer (fig. 80) as object, and read off the number of spaces required to measure the diameter of the light disc as seen in the microscope. Use first a low objective (16 mm.) and a low ocular (4x or 5x), then use the higher ocular (8x or 10x). Do the same with the 4 or 8 mm. objective and the two oculars. Make a table giving the diameter of the field in each case and compare with the accompanying table. The tube-length (fig. 25) should be 160 mm. when making the measurements. To see the effect of lengthening the tube, pull it out till the tube-length is 200 mm. and note the effect on the size of the field with one objective and the two oculars. (The longer the tube the smaller the field).

§ 49. Table showing the actual size of the field of view of various objectives and oculars with a tube-length of 160 mm.

Objective	5x Ocular	Diameter of Field in mm.	10x Ocular	Diameter of Field in mm.
40 mm.	"	7.3	"	4.85
32 mm.	"	5.3	"	3.7
25 mm.	"	3.5	"	2.55
16 mm.	"	2.15	"	1.55
12 mm.	"	1.2	"	0.85
8 mm.	"	0.97	"	0.69
4 mm.	"	0.44	"	0.31
3 mm.	"	0.31	"	0.225
2 mm.	"	0.21	"	0.155

FUNCTION OF AN OBJECTIVE

§ 50. Put a 50 mm. objective on the microscope, or screw off the front combination of a 16 mm., and put the back combination on the microscope for a low objective.

Place some printed letters or figures under the microscope, and light well. In place of an ocular put a screen of ground-glass, or a piece of lens paper, over the upper end of the tube of the microscope.

Lower the tube of the microscope by means of the coarse adjustment until the objective is within 2 to 3 cm. of the object on the stage. Look at the screen on the top of the tube, holding the head about as far from it as for ordinary reading, and slowly elevate the tube by means of the coarse adjustment until the image of the letters appears on the screen.

The image can be more clearly seen if the object is in a strong light and the screen in a moderate light, i.e., if the top of the microscope is shaded.

The letters will appear as if printed on the ground-glass or paper, but will be inverted.

If the objective is not raised sufficiently, and the head is held too near the microscope, the objective will act as a simple microscope. If the letters are erect, and appear to be down in the microscope and not on the screen, hold the head farther from it, shade the screen, and raise the tube of the microscope until the letters do appear on the ground-glass.

§ 50a. Ground-glass may be very easily prepared by placing some fine emery or carborundum between two pieces of glass, wetting it with water, and then rubbing the glasses together for a few minutes. If the glass becomes too opaque, it may be rendered more translucent by rubbing some oil upon it.

§ 51. **Aerial image.** — After seeing the real image on the ground-glass or paper, use the lens paper over about half of the opening of the tube of the microscope. Hold the eye about 250 mm. from the microscope as before and shade the top of the tube by holding the hand between it and the light, or in some other way. The real image can be seen in part as if on the paper and in part in the air. Move the paper so that the image of half a letter will be on the paper and half

in the air. Another striking experiment is to have a small hole in the paper placed over the center of the tube opening, then if a printed word extends entirely across the diameter of the tube, its central part may be seen in the air, the lateral parts on the paper. The advantage of the paper over part of the opening is to enable one to accommodate the eyes for the right distance. If the paper is absent the eyes adjust themselves for the light circle at the back of the objective, and the aerial image appears low in the tube. Furthermore it is more difficult to see the aerial image in space than to see the image on the ground-glass or paper, for the eye must be held in the right position to receive the rays projected from the real image, while the granular surface of the glass and the delicate fibers of the paper reflect the rays irregularly, so that the image may be seen at almost any angle, as if the letters were actually printed on the paper or glass.

§ 52. The function of an objective, as seen from these experiments, is to form an enlarged, inverted, real image of an object, this image being formed on the opposite side of the objective from the object (fig. 13, 20).

FUNCTION OF AN OCULAR

§ 53. Using the same objective as for § 50, get as clear an image of the letters as possible on the lens paper or ground-glass screen. Look at the image with a simple microscope (fig. 17), as if the image were an object.

Observe that the image seen through the simple microscope is merely an enlargement of the one on the screen, and that the letters remain inverted. Remove the screen and observe the aerial image with the tripod magnifier.

§ 54. Put a 4x or 5x ocular, i.e., an ocular of low magnification in position (§ 45). Hold the eye about 10 to 20 mm. from the eye-lens and look into the microscope. The letters will appear as when the simple microscope was used (see above); the image will become more distinct by slightly raising the tube of the microscope with the coarse adjustment.

§ 55. The function of the ocular, as seen from the above, is that of a simple microscope, viz. it magnifies the real image formed by

the objective as if that image were an object. Compare the image formed by the ocular (fig. 3, 20) and that formed by a simple microscope (fig. 2, 6).

It should be borne in mind, however, that the rays from an object as usually examined with a simple microscope extend from the object in all directions, and no matter at what angle the simple microscope is held, provided it is sufficiently near and points toward the object, an image may be seen. The rays from a real image, however, are continued in certain definite lines and not in all directions; hence, in order to see this aerial image with an ocular or simple microscope, or in order to see the aerial image with the unaided eye, the simple microscope, ocular, or eye must be in the path of the rays (fig. 2-3).

§ 56. The field-lens of a Huygenian ocular makes the real image smaller and consequently increases the size of the field; it also makes the image brighter by contracting the area of the real image (fig. 23, 24). Demonstrate this by screwing off the field-lens and using the eye-lens alone as an ocular, refocusing if necessary. Note that the image is bordered by a colored haze (Ch. IX).

When looking into the ocular with the field-lens removed, the eye should not be held so close to the ocular, as the eye-point (fig. 23) is considerably farther away than when the field-lens is in place.

§ 57. **Eye-point.** — This is in the plane above the ocular where the emerging rays cross (fig. 22-24). If the eye is placed at this point it will receive the greatest number of rays from the microscope and thus see the largest field. If the eye is too far from or too near the ocular, part of the rays cannot enter the pupil of the eye and the microscopic image is restricted.

Demonstrate the eye-point by using a 16 mm. objective and a 4x or 5x ocular. Light brightly and then focus the microscope on some transparent specimen. Open the diaphragm widely so that the entire aperture of the objective is filled with light (fig. 45). Shade the ocular with the hand or a screen and hold above the eye-lens a piece of ground-glass or of the lens paper. By raising and lowering the glass or paper one will find the level where the sharpest and brightest light circle is located. The height varies with different oculars. Now use the tripod or other magnifier and look at the eye-point. It is

really the image of the aperture of the objective, and, as shown later, the study of this image enables one to detect lint and other particles on the upper lens of the objective (§ 57a).

The eye-point is also known as the Pupil of the lens; Ramsden Disc or Circle; Lagrange Disc.

§ 57a. As pointed out by Wright (p. 93), a study of the eye-point with a magnifier gives very definite information and guidance on several important points:

- (1) The aperture of the light in the objective, and hence whether the diaphragm of the condenser is opened the right amount.
- (2) The centering of the condenser.
- (3) The presence of dust or other opacities on the back lens.
- (4) The partial unsealing of any of the objective combinations.
- (5) The presence of air bubbles in the immersion liquid.

§ 58. **Erect and inverted images with the microscope.** — By glancing at fig. 2, 6 it will be seen that with the simple microscope the retinal image is inverted; that is, the arrow is turned end for end. In like manner the retinal image of any object seen with the naked eye is also inverted (fig. 5).

On the other hand, with the compound microscope, the retinal image is erect (fig. 3, 20); that is, the arrow points in the same direction as the object. This is because the eye does not see the object directly, but the real image formed by the objective, and this is inverted. From the crossing of the rays on entering the eye, this inverted real image is reinverted, and thus gives an erect image on the retina. Now as objects or their images do not seem to be on the retinal screen, but out in space in the direction of the light rays entering the eye, it is very evident that if the light rays are traced from the retinal image to the object or to a virtual image, this will appear to be erect when the image on the retina is inverted, and it will appear inverted when the retinal image is erect, because of the crossing of the rays in passing the pupil of the eye (fig. 2, 3, 6, 20) on their way to the retinal image, or on their way from the retinal image to the apparent position of the object or the virtual image.

COLLATERAL READING

BEALE, L. S. — How to Work with the Microscope.

CARPENTER-DALLINGER. — The Microscope and its Revelations.

CHAMOT, E. M. — Elementary Chemical Microscopy.

HOWELL, W. H. — A Text-book of Physiology.

SPITTA, E. J. — Microscopy, the Construction, Theory and Use of the Microscope.

WINSLOW, C. E. A. — Elements of Applied Microscopy.

WRIGHT, SIR A. E. — Principles of Microscopy.

Journal of the Royal Microscopical Society. (See the Bibliography at the end.)

CHAPTER II

FOCUSING THE MICROSCOPE; WORKING DISTANCE; LIGHTING WITHOUT AND WITH A CONDENSER; ARTIFICIAL DAY-LIGHT; DARK GROUND ILLUMINATION

§ 68. Apparatus and material for Chapter II.

1. Microscope supplied with plane and concave mirror, achromatic and Abbe condensers, dry, adjustable and immersion objectives, oculars, triple nose-piece (fig. 25).
2. Lamp or lantern for microscopic work (fig. 37-38); opaque screen.
3. Homogeneous immersion liquid; xylene; alcohol; distilled water.
4. Mounted preparation of fly's wing; lint; samples of starch.
5. Simple microscope; steel scale ruled in $\frac{1}{2}$ mm.
6. Preparation of Pleurosigma (§ 98, 115); piece of black velvet.
7. Stage micrometer (fig. 80).
8. 10% solution salicylic acid in 95% alcohol; cedar oil.
9. Glass slides and cover-glasses (Ch. X).
10. Preparation of stained bacteria.
11. Vial of equal parts olive or cottonseed oil, or liquid vaseline and xylene.
12. Black and colored ink; pencils.
13. Gum arabic mucilage.
14. Dark ground condenser (§ 125).
15. Small arc lamp (fig. 49).

FOCUSING

§ 69. **Focusing is mutually** arranging an object and the microscope so that a clear image may be seen.

With a simple microscope either the object or the microscope or both may be moved in order to see the image clearly, but with the compound microscope the object more conveniently remains stationary on the stage, and the tube or body of the microscope is raised or lowered (fig. 25).

In general, the higher the power of the whole microscope, whether simple or compound, the nearer together must the object and the objective be brought. With the compound microscope, the higher the objective, and the longer the tube of the microscope, the nearer together must the object and the objective be brought. If the oculars are not parfocal, the higher the magnification of the ocular, the nearer must the object and objective be brought.

FOCUSING EXPERIMENTS

§ 70. **Focusing low objectives.** — Place a mounted fly's wing under the microscope; put the 16 mm. objective and the 4x or 5x ocular in position. Select the proper opening in the diaphragm and light the object well with transmitted light (§ 85).

Hold the head at about the level of the stage, look toward the window, and between the object and the front of the objective; with the coarse adjustment lower the tube until the objective is within about half a centimeter of the object. Then look into the microscope and slowly elevate the tube with the coarse adjustment. The image will appear dimly at first, but will become very distinct by raising the tube still higher. If the tube is raised too high the image will become indistinct, and finally disappear. It will again appear if the tube is lowered the proper distance.

When the microscope is well focused try both the concave and the plane mirrors in various positions and note the effect.

Pull out the draw-tube 4 to 6 cm., thus lengthening the body of the microscope; it will be found necessary to lower the tube of the microscope somewhat (for reason, see fig. 83).

§ 71. **Pushing in the draw-tube.** — To push in the draw-tube, grasp the large milled ring of the ocular with one hand, and the milled head of the coarse adjustment with the other, and gradually push the draw-tube into the tube. If this were done without these precautions the objective might be forced against the object and the ocular thrown out by the compressed air.

§ 72. **Focusing with high objectives.** — Employ the same object as before, elevate the tube of the microscope and, if no revolving nose-piece is present, remove the 16 mm. objective as indicated. Put a 4 mm. or higher objective in place, and use a 4x or 5x ocular.

Light well, and employ the proper opening in the diaphragm, etc. (§ 89). Look between the front of the objective and the object as before (§ 70), and lower the tube with the coarse adjustment till the objective almost touches the cover-glass over the object. Look into the microscope, and with the coarse adjustment, raise the tube very slowly until the image begins to appear, then turn the milled head of

the fine adjustment (fig. 25), first one way and then the other, until the image is sharply defined.

In practice it is found of great advantage to move the preparation slightly while focusing. This enables one to determine the approach to the focal point either from the shadow or the color, if the object is colored. With high powers and scattered objects there might be no object in the small field (§ 47, fig. 29 for size of field). By moving the preparation an object will be moved across the field and its shadow gives one the hint that the objective is approaching the focal point. It is sometimes desirable to focus on the edge of the cement ring or on the little ring made by the marker (fig. 61).

§ 73. **Always focus up, as directed above.** — If one lowers the tube only when looking at the end of the objective as directed above, there will be no danger of bringing the objective in contact with the object, as may be done if one looks into the microscope and focuses down.

When the instrument is well focused, move the object around in order to bring different parts into the field. It may be necessary to refocus with the fine adjustment every time a different part is brought into the field. In practical work one hand is kept on the fine adjustment constantly, and the focus is continually varied.

§ 74. **Parfocal oculars and focusing.** — On changing the oculars from a higher to a lower or the reverse it is necessary to refocus the microscope. Formerly the change in focus was very marked in changing from one power of ocular to another, but since Mr. Pennock introduced parfocal oculars (1881) and their almost universal adoption since, very little change in focus is necessary in passing from power to power of ocular (see Ch. IX).

§ 75. **Parfocal objectives.** — These are groups of objectives, of different power, so mounted that when screwed into the revolving nose-piece of the microscope very little change in focusing is necessary in passing from objective to objective. This arrangement of objectives was a natural outgrowth from the parfocalization of the oculars (§ 74).

In case the objectives are not nearly enough parfocal so that the object is visible in turning from one objective to another, the defect

can be easily corrected by getting one of the objectives in exact focus and then turning the others successively into place. If one notes whether it is necessary to focus up, then it will be known that the objective projects too far down toward the object; if, on the other hand, one must focus down, then the objective is too high up. To correct this lack of parfocalization use the objective which projects farthest toward the object as standard. Focus it sharply and then turn another in position. Unscrew this slowly until the image is also sharp. Now wind a thread or string around the lower end of the objective screw and then turn it in place and slowly screw it into the revolving nose-piece until it is in focus. Proceed with all until the entire number are in focus at the same level. With parfocal oculars and parfocal objectives much time and annoyance is saved, for one can see the specimen in turning from power to power, and it is only necessary to make a small focusing adjustment to get the best image.

§ 76. **Working distance.** — By this is meant the space between the simple microscope and the object, or between the front lens of the compound microscope and the object, when the microscope is in focus. This working distance is always considerably less than the equivalent focal length of the objective. For example, the front-lens of a 4 mm. objective would not be 4 millimeters from the object when the microscope is in focus, but considerably less than that distance, viz. less than half a millimeter. If now a cover-glass of half a millimeter or more in thickness were used it would be impossible to get the 4 mm. objective near enough the object to get it in focus. It is not uncommon for students to put their microscopic specimens on the stage of the microscope wrong side up. Then the thickness of the slide is over the object. With low powers the object can still be put in focus; but not with high powers, as the working distance is not great enough. See also aberrations produced by the cover-glass (fig. 51).

§ 77. **Free working distance.** — (1) Where no cover-glass is used this is the distance between the front of the magnifier or the front lens mount of the objective and the object (fig. 30).

(2) If a cover-glass is used, it is the distance between the upper surface of the cover-glass and the magnifier or objective when the

microscope is in focus (fig. 31, 34). Strictly speaking, it is the distance between the objective front and the upper surface of a cover-glass of the exact thickness for which the objective is corrected (see table of tube-length and cover-glass thickness, Ch. IX).

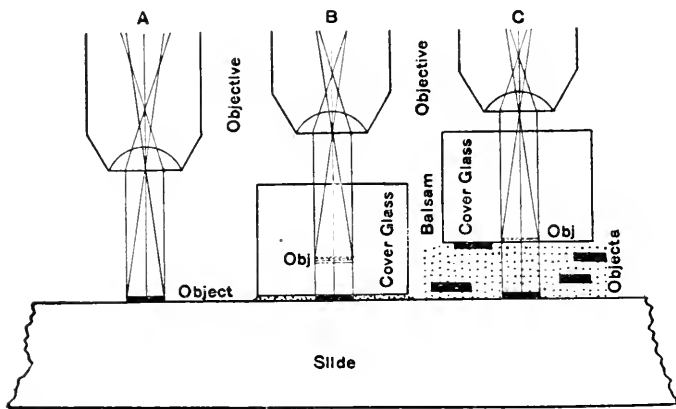

FIG. 30, 31, 32. WORKING DISTANCE AND THE COVER-GLASS.

Slide The glass slide upon which the object is mounted.

A Working distance with an uncovered object.

B Working distance when a cover-glass is used and the object is in contact with the cover-glass. The object represented by the solid black oblong appears to be elevated one third the thickness of the cover to the level *Obj.*, where it is represented by dots.

The objective is elevated corresponding to the apparent elevation of the object.

C Working distance when a cover-glass is used and the objects are distributed in a stratum of Canada balsam.

It is evident from this figure why the focus must be different for objects at different depths in the balsam.

As the working distance of an objective is practically always less than its equivalent focus, one must take care to use cover-glasses thin enough so that any suitable objective can be used for studying the specimen. Furthermore, as microscopic specimens have considerable thickness, the cover-glass should be thin enough so that the objective can be lowered sufficiently to enable one to bring the lower strata of the specimen in focus without bringing the objective front in contact with the upper surface of the cover-glass (fig. 32).

DETERMINATION OF WORKING DISTANCE

§ 78. **Working distance, no cover.** — As stated in § 77, this is the distance between the front lens or mounting of the front lens of the objective and the object when the objective is in focus. It is always less than the equivalent focal length of the objective.

Make a wooden wedge 10 cm. long which shall be exceedingly thin at one end and about 20 mm. thick at the other. Place a slide on the stage and some dust or an ink or pencil mark on the slide. Do not use a cover-glass. Use a 16 mm. objective and focus the dust or mark carefully, and when the objective is in focus push the wedge between the objective and slide until it touches the objective. Mark the place of contact with a pencil and then measure the thickness of the wedge with a rule opposite the point of contact. This thickness will represent very closely the working distance. For measuring the thickness of the wedge at the point of contact for the high objective use a steel scale ruled in $\frac{1}{2}$ mm. and the tripod magnifier to see the divisions. Or one may use a cover-glass measurer (Ch. X) for determining the thickness of the wedge.

For the higher powers, if one has a microscope in which the fine adjustment is graduated, the working distance may be readily determined as follows:

Use the marked slide as above. Get the dust or mark in focus, then lower the tube of the microscope until the front of the objective just touches the slide. Note the position of the micrometer screw and slowly focus up with the fine adjustment until the dust or mark is again in focus. By noting the total and partial revolutions of the graduated fine adjustment the working distance will be known. For example, suppose it required 5.5 revolutions of the micrometer screw to raise the objective from the surface of the slide where the object is located to a point where the microscope is in focus, and the micrometer screw raises the objective 0.1 mm. for each complete revolution, then the total elevation will be $0.1 \times 5.5 = 0.55$ mm., that is, the working distance in this case is 0.55 millimeter.

§ 79. **Free working distance in covered objects.** — Use a 4 mm. objective and the fly's wing or any covered object. Set the fine ad-

justment head at zero (o). Lower the objective carefully with the coarse adjustment until the objective just touches the cover-glass. Now focus up with the fine adjustment until the object is in sharp focus, noting the total and partial revolutions of the screw to accomplish this. The distance the objective was raised is the free space between the front of the objective and the cover-glass. Suppose it required 3.2 revolutions of the fine adjustment to focus the objective, then if each revolution represents 0.1 mm. the total elevation is $3.2 \times 0.1 = 0.32$ mm. for the free working distance in this case.

§ 80. **Effect of the cover-glass on the working distance.** — It is obvious that if an object is covered with a layer of glass that the free space between the front of the objective and the object will be lessened, and if the layer of glass is considerably thicker than the working distance of the objective, then it will be impossible to get the object in focus. If the layer of glass is relatively thin, then it will be possible to focus the microscope on the object, but from the law of refraction it necessarily follows that the focus of the microscope with and without a cover-glass will not be the same.

Now from the refraction of the rays in passing from one medium to another of different refractive power, it follows that, when an object is in or below a stratum of glass or water or other highly refractive body, the object will appear as if raised (fig. 31, 51), the amount of the apparent elevation depending on the refractive index of the covering body, — the greater its refraction, the more the apparent elevation. The general physical law is that the eye being in the air the apparent depth of an object below the surface when viewed perpendicularly is the actual depth multiplied by the reciprocal of the index of refraction of the covering body. The index of refraction of the cover-glass is 1.52 or approximately 1.50, and its reciprocal is $\frac{1}{1.5} = \frac{2}{3}$. That is, the apparent depth is only $\frac{2}{3}$ its actual depth, or in other words the object seems to be elevated $\frac{1}{3}$ of the actual depth.

Now if the object is apparently higher up, the microscope must be raised an amount equal to the apparent elevation of the object. This is illustrated in fig. 31-32. From this it follows that the free working distance of the objective on a covered object is not lessened the full thickness of the cover-glass, but only $\frac{2}{3}$ of that thickness.

§ 81. **Demonstration that the working distance is lessened $\frac{2}{3}$ the thickness of the cover-glass.** — Use a clean, flat glass slide. Put an ink or pencil mark on the upper face for object. Employ a 16 mm. objective and 8x or 10x ocular. Focus the microscope on the ink or pencil mark, then measure the free space between the slide and the end of the objective with the wooden wedge, as directed in § 78. This is the free working distance (§ 77) without a cover-glass.

Cut a glass slide up into two or three pieces for cover-glasses. Measure the thickness of one of the pieces with the cover-glass measurer or in some other good way. Place this over the mark on the slide which was in focus. If now one looks into the microscope the mark will not be in focus with the glass cover over it. Focus up carefully until the mark is again in focus. Measure the space between the top of the cover-glass and the objective with the work as before. This will represent the free working distance with this cover-glass.

Subtract the free working distance with this cover-glass from that with no cover-glass and the difference will be the amount the free working distance has been lessened by the addition of the cover. This amount compared with the thickness of the cover-glass will give the ratio of lessening of working distance by the addition of the cover-glass.

In an actual case the results were as follows:

Free working distance without cover	4.62 mm.
“ “ “ with cover	3.54 mm.
Lessening of the working distance by the cover-glass	1.08 mm.
The actual thickness of the cover-glass was	1.62 mm.

That is, the lessening of the free working distance was not so great as the thickness of the cover (1.62 mm.), but less; viz. 1.08 mm.; that is, in the proportion of $\frac{1.08}{1.62} = \frac{2}{3}$ of the actual thickness of the cover-glass.

§ 82. **Determining the thickness of the cover-glass with mounted objects.** — From what has been learned about the free working distance with covered objects, it is possible to determine the thickness of the cover-glass over an object if the object is in contact with the cover. If it is below, as shown in fig. 32, and the mounting medium is Canada balsam with approximately the same refractive index as

glass, then it is possible to determine how great is the combined thickness of the cover-glass and layer of Canada balsam over the object.

Demonstrate the method as follows: (1) Where the object is in contact with the lower surface of the cover-glass (fig. 31). Use a 4 mm. objective and a cover-glass $\frac{1.5}{100}$ mm. thick. Make a black ink mark on one side of the cover and a colored ink mark directly opposite on the other side of the cover, or use glass pencils of two colors. Set the graduations of the fine adjustment at zero (o). Place the marked cover on a glass slide, and put under the microscope. Focus with the coarse adjustment on the mark at the upper surface of the cover. Then focus down with the fine adjustment until the mark on the lower surface appears sharp. For verification, focus up until the upper mark is again sharp. The elevation will of course be the same as the lowering. If the total and partial revolutions of the fine adjustment screw are noted, they will show how much the objective was lowered to get the lower mark in focus. In the case here given it was lowered 1 revolution. Now as each revolution moves the objective up or down 0.1 mm. the objective was moved down 0.1 or $\frac{1.0}{100}$ of a millimeter. As this represents $\frac{2}{3}$ of the thickness of the cover from the effect of refraction, the whole thickness must be $0.10 \div \frac{2}{3} = 0.15$ mm. For a cover of unknown thickness with the object in contact with its under surface, put an ink mark on the upper surface of the cover and proceed exactly as above, focusing successively on the object and on the ink spot.

(2) Where the object is somewhere below the cover-glass (fig. 32). In this case the thickness of the cover-glass cannot be determined, but one can determine very approximately the combined thickness of the cover-glass and the mounting medium over the object as follows: Put an ink or glass pencil mark on the upper surface of the cover-glass. Focus the mark with the coarse adjustment after setting the graduations of the fine adjustment at zero (o). Then focus down with the fine adjustment until the object is sharp. Note the number of revolutions and the partial revolution of the fine adjustment drum. As this amount represents only $\frac{2}{3}$ of the actual thickness of the glass and mounting medium over the object, divide the observed

amount of movement by $\frac{2}{3}$ and the quotient will represent the total thickness over the object.

For example, in one case the microscope was focused on the ink mark at the top of the cover, and then it was necessary to focus down $1\frac{1}{2}$ revolutions of the fine adjustment screw to bring the object in focus. That is, it was necessary to focus down 0.15 mm. Now as this represents but $\frac{2}{3}$ of the actual thickness of the cover-glass and mounting medium over the object, the entire thickness was $0.15 \div \frac{2}{3} = 0.225$ mm. Probably in this case the cover-glass was 0.15 mm. thick and the object was in the mounting medium 0.075 mm. below the cover.

LIGHTING WITH DAYLIGHT

§ 83. **Unmodified sunlight** should not be employed except in special cases (§ 125). North light is best and most uniform. When the sky is covered with white clouds, the light is most favorable. To avoid the shadows produced by the hands in manipulating the mirror, etc., it is better to face the light; but to protect the eyes and to shade the stage of the microscope some kind of screen should be used. The one shown in fig. 33 is cheap and efficient. If one dislikes to face the window or lamp it is better to sit so that the light will come from the left, as in reading.

It is of the greatest importance and advantage for one who is to use the microscope for serious work that he should comprehend and appreciate thoroughly the various methods of illumination, and the special appearances due to different kinds of illumination.

§ 84. **Reflected, incident, or direct light.**

— By this is meant light reflected upon the object in some way and then irregularly reflected from the object to the microscope. By this kind of light objects are ordinarily seen by the unaided eye and the simple microscope (fig. 4-5). In Histology,

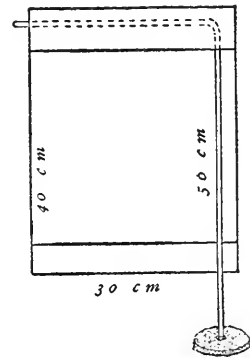

FIG. 33. SCREEN FOR SHADING THE MICROSCOPE AND THE OBSERVER.

It is composed of heavy paper hung over a bent wire, which in turn is anchored in a small tin dish filled with lead.

reflected light is but little used; but in the study of opaque objects, like whole insects, etc., it is used a great deal. For a simple microscope and low powers of the compound microscope, ordinary daylight that naturally falls upon the object, or is reflected or condensed

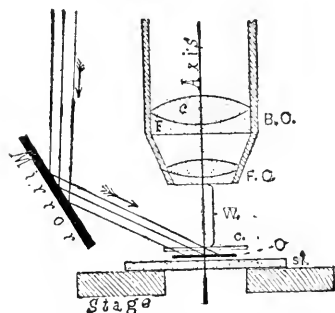

FIG. 34. LOW-POWER OBJECTIVE SHOWING WORKING DISTANCE AND REFLECTED LIGHT.

Axis The principal optic axis of the objective extended.

Sl The glass slide on which the object is mounted.

O Object.

c Cover-glass over the object.

W The working distance between the cover and the objective.

Mirror The mirror is represented as above the stage and reflecting parallel beams upon the object.

FC Front combination of the objective.

BC Back combination of the objective; it is composed of a plano-concave of flint (*F*) and a double convex lens of crown glass (*c*).

upon it with a mirror or condensing lens, answers very well (fig. 21 A, 34). For high powers and for special purposes, special illuminating apparatus has been devised (fig. 50).

§ 85. **Transmitted light.** — By this is meant light which passes through an object from the opposite side (fig. 21 B, 35). The details of a photographic negative are in many cases only seen or best seen by transmitted light, while the print made from it is best seen by reflected light (fig. 21 A, 34).

Almost all objects studied in animal and vegetable Histology are lighted by transmitted light, and they are in some way rendered transparent or semi-transparent. The light traversing and serving to illuminate the object in working with a compound microscope is usually reflected from a plane or concave mirror, or from a mirror to a condenser, and thence transmitted to the object from below (fig. 20, 41).

§ 86. **Axial or central light.** — By this is meant light reaching the object in such a way that it is symmetrically arranged around the optic axis of the microscope, then the object will be equally illuminated from all sides. If bundles of parallel rays are reflected upon the object from the mirror, they must be so disposed that the object will receive an equal quantity of light

from all sides. If the bundles of light are made up of diverging or of converging cones, then the axes of the cones should be coincident with or parallel with and symmetrically arranged around the optic axis of the microscope (fig. 41-42).

§ 87. **Oblique light.** — By this is meant light which reaches the object with its axial beam oblique to the optic axis of the microscope. With oblique light the object cannot be illuminated equally from all sides, but largely from one side, and consequently the light is said to be unsymmetrical.

If no condenser is used, oblique light is obtained by turning the mirror so that parallel rays strike the object obliquely to the optic axis of the microscope (fig. 35 *c*) or the axis of the converging or diverging beam from the concave mirror strikes the optic axis obliquely (fig. 35).

If a condenser is used, oblique illumination is produced by making the diaphragm opening eccentric, or most simply by putting the finger or other opaque body between the mirror and the condenser to cut off part of the light (fig. 46, 67). The end result in all cases is that the object is lighted unsymmetrically.

§ 88. **Use of a diaphragm.** — A diaphragm is an opaque disc with an opening, and is placed somewhere between the object and the source of light.

At the present time an iris diaphragm is almost universally employed. It, like the iris of the eye, can be expanded or contracted, and thus gives a large range of openings to meet different conditions.

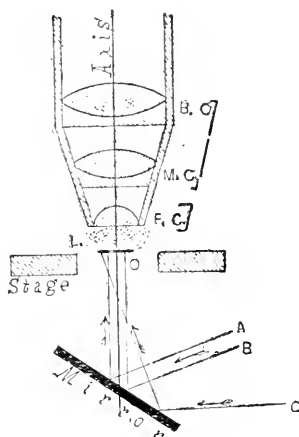

FIG. 35. HIGH-POWER IMMERSION OBJECTIVE WITH DIRECT AND OBLIQUE TRANSMITTED LIGHT.

- Axis* The principal optic axis.
Mirror This reflects the light up through the object.
A B Direct light.
C Oblique light.
Stage The microscope stage in section.
O The object.
I Immersion liquid between the objective and object.
F C The front lens of the objective.
M C The middle combination.
B C The back combination.

The object of a diaphragm is to cut off adventitious light and to vary the aperture to suit the object and the objective.

§ 89. **Size and position of the diaphragm with a mirror only.** — When no condenser is used in addition to the mirror, a diaphragm opening about the size of the front lens of the objective may be employed. Its position may be close to the object, in which case it admits the greatest aperture of light, and cuts off the most adventitious light; in this position it lights the smallest field, however.

If the diaphragm is far enough below the object the field may all be lighted, but the aperture will be smaller than when it is close to the object, as one may see by removing the ocular and looking down the tube into the back lens of a 16 mm. or 8 mm. objective. On the other hand, while the aperture of the objective may be filled even with a small diaphragm opening close to the object, the field of view (§ 47, fig. 65) may be but partly lighted. In that case the opening must be increased until the entire field is illuminated. One must learn by practice how to get the best effects.

§ 90. **Diaphragm with condenser.** — The diaphragm with a condenser serves to vary the aperture of the cone of light to adapt it to the objective, and to the object.

If the opening in the diaphragm is not in the axis of the condenser the object will be unsymmetrically illuminated; the object will also be unsymmetrically illuminated if the diaphragm is wide open but the light blocked from one side by placing an opaque body, like the finger, between the mirror and the diaphragm (fig. 46, 67).

The diaphragm is below the condenser in many forms, but between the lenses in some (fig. 39-42).

ARTIFICIAL ILLUMINATION

§ 91. **Artificial light.** — While daylight is to be preferred for most microscopic as for other exacting work, it is not always possible to work by daylight, and then sometimes one's work room or laboratory is so situated that, even in the daytime, artificial light must be employed. For some purposes, like photo-micrography, it is desirable to have a very uniform light, and this is gained most readily by using some form of artificial light.

All forms of artificial light have been used at some time for microscopic work. For photography and for drawing (Chs. VI-VII) the arc light has been found most satisfactory. For the usual observational work with the microscope the effort has been made for a long time to get an artificial light which should approximate daylight as closely as possible. This desire for artificial daylight is natural, as the eye has been created or developed for daylight, and any form of light differing in a marked degree from daylight does not give standard color values, and is liable to cause eye fatigue if some parts of the visible spectrum are markedly brighter than with daylight. In all of the ordinary forms of artificial light, the relative intensity toward the red end of the spectrum is very much greater than with daylight (fig. 36); hence color values are distorted, and with most people the excessive red intensity produces a glare and lack of contrast which is trying to the eyes.

§ 92. **Artificial daylight.** — For the production of artificial daylight it is obvious from the curve here shown that there are two possible means: (1) The selection of two kinds of artificial light in which the lack in one is made good by the excess in another, and by mixing these in the right proportions the resulting light will have the same relative intensity in different parts of the spectrum as is found in sunlight. This is the "additive" method and has been quite successfully realized by combining a mercury arc light with its deficiency in the red, but its richness in intensity in the blue end of the spectrum, with a mazda incandescent lamp with its excessive red intensity. If these two lights are enclosed in a glass globe, and the right amount of each used, very good daylight is produced.

(2) As there is excessive intensity in the red part of the spectrum it is evident that if this excess can be absorbed by a light filter of some kind, then also the relative intensity of the light will be like that of natural daylight. This is the "subtractive" method, and is the method employed wherever a light filter or colored liquid, colored gelatin, colored glass, or a combination is used. From time immemorial various colored liquids like solutions of copper salts and colored glasses have been used to whiten the artificial light.

During the last few years, however, the problem has been solved,

and now colored glass is made which gives to artificial light true daylight qualities. As each artificial light has its own special curve

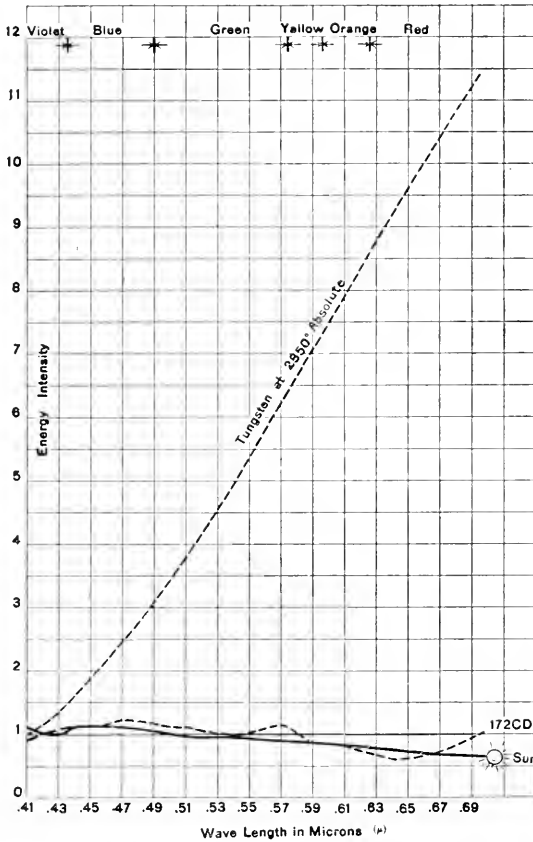

FIG. 36. CURVE OF ENERGY DISTRIBUTION IN MAZDA C LAMP, THE SUN AND THE LAMPLIGHT FILTERED THROUGH DAYLIGHT GLASS (172 CD).

(From the Sibley Journal and the Anatomical Record).

of intensity for the different parts of the spectrum, naturally a special light filter must be worked out for each light source. Up to the present, glass filters have been produced for the welsbach gas light,

and for the incandescent, nitrogen-filled, tungsten (mazda) lamp. It may be said in passing that these glass filters whiten any artificial light, but that true daylight color values are given only under the precise conditions for which the glass was worked out. It is also gratifying to note that this successful solution of a long vexing problem came only when the rigid training in physics and chemistry and the facilities of a great manufacturing plant were brought together.

In the practical use of these daylight filters it was found by me that the surface should be finely ground (frosted), or white frosted glass should be used with it. Then the light should be enclosed in some form of lantern to cut off all unfiltered light, and the daylight glass placed opposite the fil-

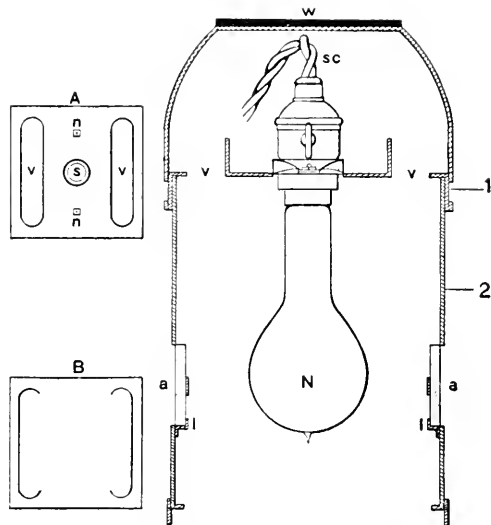

FIG. 37. LANTERN FOR DAYLIGHT GLASS IN SECTION $\times \frac{1}{4}$.

(From the *Anatomical Record*, June, 1916).

1 top of the lantern supporting the lamp. It sets down on the lower part like the cover of a pail. *v* Ventilating slits. The tin from these slits is turned up at right angles; *sc* the porcelain socket with key switch, and the asbestos insulated cable for the current; *N* the 100-watt nitrogen-filled mazda lamp; *w* The flat warming plate on the top of the cover. It is a brass plate about three millimeters thick. The temperature on this plate is about 40 to 45° C. and serves for spreading paraffin sections, etc. *2* The lower part of the lantern containing the daylight glass. It is square in cross-section, as shown by *A, B*.

a Daylight glass in the apertures of the lantern. The pieces of glass are about 5 cm. in diameter. *l* Lugs to hold the daylight glass in position; *1* the partition containing the lamp socket seen from below. *v* Ventilating slits. *n* Nuts at the ends of the bolts holding the metal clamp for the lamp socket; *B* Bottom of the lantern. It is about 15 mm. from the table, thus permitting an intake space for air. Paraffin infiltration can be done here if one is careful. (*A, B*, are only about $\frac{1}{3}$ natural size.)

ament of the lamp as shown in fig. 38, where the N represents the filament.

So used, the brightly illuminated frosted daylight glass becomes practically the source of light for the microscope, and resembles very closely that from a white cloud. There is no glare, the color values are correct, and if a 100-watt, nitrogen-filled, mazda lamp is used, the light is abundant for all powers of the microscope up to and including the 1.5 mm. oil immersion.

For objectives up to 8 mm. it is best to have the daylight glass ground on both sides. The diffusion will then be sufficient to give a uniformly lighted field. For powers of 4, 3, 2, and 1.5 mm, focus it is better to have one side of the daylight glass polished and one side ground. This gives sufficient diffusion of the light from the source to fully and evenly light the field, and as the diffusion is less the brilliancy of the light will be correspondingly greater from the smaller area. A good plan is to have one opening of the lantern (fig. 37-38) with a disc of glass ground on both sides for low power work and another with the daylight glass frosted on one side and polished on the other for high powers.

It may be said that the position of the ground-glass filter should be close to the source of light. Its brilliancy will vary inversely with the square of its distance from the lamp filament. If the daylight glass were polished, then it could be used anywhere between the source of light and the eye; for example, under the condenser in the usual place for polished colored glasses, or over the ocular. The advantage of having it ground and near the lamp filament is that one can get a uniform light and wholly avoid the image of the lamp filament. Furthermore, when using a lamp it should be enclosed to avoid the general flooding of the room with unfiltered light, to say nothing of the annoyance to the observer and his coworkers. The enclosure in a lantern (fig. 37-38) avoids all that (92a).

§ 92a. For a discussion of the requirements for the production of artificial daylight, and the means so far employed, and the uses of artificial daylight, see: Herbert E. Ives. *Artificial Daylight*. Journal of the Franklin Institute, vol. 177, May, 1914, pp. 471-499. 10 figures.

Simon H. Gage. *Artificial Daylight for the Microscope*. Science, N. S., vol. 42, October, 1915, pp. 534-536. One curve.

M. Luckiesh. Artificial Daylight. *Science*, N. S., vol. 42, November, 1915, pp. 764-765.

Henry Phelps Gage. "Daylite Glass," a color screen for producing daylight artificially. *The Sibley Journal of Engineering*, Ithaca, N. Y., Vol. XXX, No. 8, May, 1916. 4 quarto pages, 6 figures.

Simon H. Gage and Benjamin F. Kingsbury. Some apparatus for the microscopical laboratory. *Anatomical Record*, Vol. X, No. 8, June, 1916, pp. 527-536. 7 figures showing the use of the daylight glass for microscopic work.

Anthony J. Brown. Some uses of artificial daylight in the psychological laboratory. *American Journal of Psychology*. July, 1916, Vol. XXVII, pp. 427-429.

LIGHTING EXPERIMENTS WITH THE SIMPLE MICROSCOPE

§ 93. **Opaque objects.** — For these the light strikes the surface and is reflected, mostly in an irregular manner so that the object can be seen almost equally well illuminated from any angle. Ordinarily the daylight falling upon the object will sufficiently illuminate it, also the light of a lamp.

Place a printed page in bright daylight or near a lamp where the light can shine upon it and then look at it with the simple microscope held in the hand, on the legs of the tripod (fig. 4, 17-19) or held by a special stand. By varying the distance between the microscope and the object one can soon find the best focus, and by changing the position of the object, the best position for the light available.

Of course if one wishes to discriminate colors precisely, daylight, natural or artificial, must be available.

Take some object in the hand and hold it in a good light and then look at it through a simple microscope held in the other hand.

Remember in using the simple microscope that the eye should be near the microscope to see the largest field (§ 15, 47, 57), and, as will be more fully shown when dealing with magnification, the nearer the object is to the principal focus the greater will be the apparent increase in size (fig. 13-16).

LIGHTING EXPERIMENTS WITH THE COMPOUND MICROSCOPE

§ 94. **Daylight with a mirror.** — As the following experiments are for mirror lighting only, remove the substage condenser if one is present (see § 100, for condenser). Place a mounted fly's wing under the microscope, put the 16 mm. or other low objective in position, also

a 4x or 5x ocular. With the coarse adjustment lower the tube of the microscope to within about 1 cm. of the object. Use an opening in the diaphragm about as large as the front lens of the objective; then with the plane mirror try to reflect light up through the diaphragm upon the object. One can tell when the field (§ 47) is illuminated by looking at the object on the stage, but more satisfactorily by looking into the microscope. It sometimes requires considerable manipulation to light the field well. After using the plane side of the mirror turn the concave side into position and light the field with it. As the concave mirror condenses the light, the field will look brighter with it than with the plane mirror. It is especially desirable to remember that the excellence of lighting depends in part on the position of the diaphragm (§ 88). If the greatest illumination is to be obtained from the concave mirror, its position must be such that its focus will be at the level of the object. This distance can be very easily determined by finding the focal point of the mirror in full sunlight.

§ 95. **Use of the plane and of the concave mirror.** — The mirror should be freely movable, and have a plane and a concave face (fig. 20). The concave face is used when a large amount of light is needed, the plane face when a moderate amount is needed or when it is necessary to have parallel rays or to know the direction of the rays.

EXPERIMENTS WITH ARTIFICIAL LIGHT AND A MIRROR

§ 96. **Lighting with a kerosene lamp.** — For this a lamp with a flat wick from 3 to 5 cm. wide is best. It should be turned up well, but not enough to smoke. The face of the flame should be turned toward the microscope for low powers. For moderate powers the flame should be made oblique and for high powers the edge of the flame should be used. This is because the thicker source of light gives a greater brilliancy. Use the fly's wing or any well-stained preparation.

As the light is in diverging beams it is best to use the concave mirror to partly overcome the divergence. One must learn by experience and trial how far off to have the lamp. A distance of 15 to 20 cm. is usually satisfactory. There should be an opaque screen between the lamp and the microscope to protect the eyes of the observer and to screen the stage of the microscope (fig. 33).

This lamp illumination is brilliant, but the color values are quite unlike those given by daylight.

§ 97. **Lighting with artificial daylight.** — For the source of light use preferably a 75 or 100 watt nitrogen-filled mazda lamp enclosed

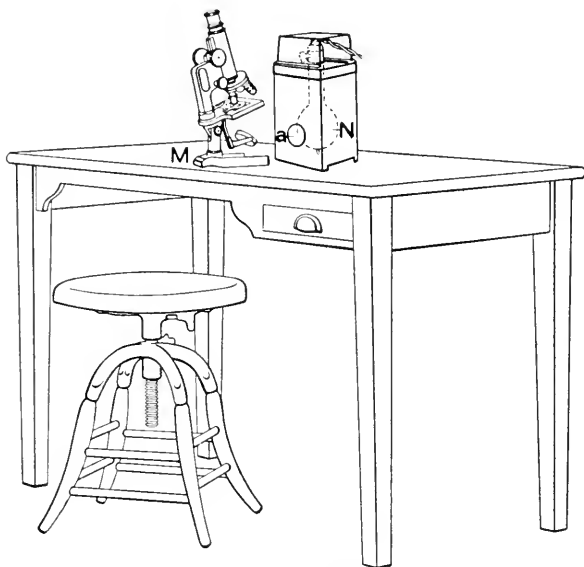

FIG. 38. LABORATORY TABLE, STOOL, MICROSCOPE, AND DAYLIGHT LANTERN, $\times 1/15$.

(From the *Anatomical Record*, June, 1916).

M Microscope; *N* Nitrogen-filled mazda lamp of 100 watts; *a* Aperture for the daylight glass. This is about 5 cm. in diameter. The arched covering at the top is open on one side only, at the right in this figure. It will be noted that the table rail is cut out in front to avoid interference with the legs of the observer, and the table drawer is at the right and can be pulled out without moving. The seat is a revolving, adjustable piano stool.

in a kind of lantern (fig. 37-38). Have the lamp filament at about the level of the center of the microscope mirror, and a frosted disc of daylight glass, before an aperture in the lantern. The aperture for the daylight glass should be from 5 to 10 cm. in diameter. For all high powers the small size is sufficient. For objectives of 50 to

100 mm. equivalent focus, the entire field might not be lighted with so small a disc of daylight glass.

For object, use a fly's wing or any good, well-stained specimen. It would be interesting to sit near a window, and to turn the mirror in such a way as to bring in daylight a part of the time. In this way one can get a good idea of the real similarity of the artificial and of the natural daylight. If one also had an electric lamp without any light filter one could pass in order from real daylight, through the artificial daylight and then on to the unmodified artificial light. Without seeing these in comparison, one is hardly able to appreciate the likeness between the natural and artificial daylight and the great unlikeness of unfiltered electric light and artificial daylight.

CENTRAL AND OBLIQUE LIGHT WITH A MIRROR

§ 98. **Axial or central light** (§ 86). — Remove the condenser or any diaphragm from the substage, then place a preparation containing minute air bubbles under the microscope. The preparation may be easily made by beating a drop of mucilage on the slide and covering it (see Chs. IX-X). Use a 4 mm. objective and a 4x or 5x ocular. Focus the microscope and select a very small bubble, one whose image appears about 1 mm. in diameter, then arrange the plane mirror so that the light spot in the bubble appears exactly in the center. Without changing the position of the mirror in the least, replace the air bubble preparation by one of *Pleurosigma angulatum* or some other finely marked diatom. Study the appearance very carefully.

§ 99. **Oblique light** (§ 87). — Swing the mirror far to one side so that the rays reaching the object may be very oblique to the optic axis of the microscope. Study carefully the appearance of the diatom with the oblique light. Compare the appearance with that where central light is used. The effect of oblique light is not so striking with histological preparations as with diatoms.

It should be especially noted in § 98-99, that one cannot determine the exact direction of the rays by the position of the mirror. This is especially true for axial light (§ 98). To be certain the light is axial some such test as that given in § 195 should be applied.

CONDENSERS OR ILLUMINATORS

§ 100. **Condensers.** — These are lenses or lens systems for the purpose of illuminating with transmitted light the object to be studied with the microscope (§ 100a).

For the highest kind of investigation their value cannot be overestimated. They may be used either with natural or artificial light, and should be of sufficient numerical aperture (N.A.) to satisfy the widest angle objectives to be used.

It is of great advantage to have the substage condenser mounted so that it may be moved up and down under the stage. An iris diaphragm is now almost universally employed, and with some there is a scale showing the numerical aperture (N.A.) of the cone of light given in each position of the iris. Finally it is an advantage to have a stop holder and diaphragms with central stops under the condenser for the production of dark-ground illumination (§ 122).

Condensers or illuminators fall into two great groups, the achromatic, giving a large aplanatic cone, and non-achromatic, giving much light, but a relatively small aplanatic cone of light.

§ 100a. No one has stated more clearly, or appreciated more truly the value of correct illumination and the methods of obtaining it than Sir David Brewster, 1820, 1831. He says of illumination in general: "The art of illuminating microscopic objects is not of less importance than that of preparing them for observation." "The eye should be protected from all extraneous light, and should not receive any of the light which proceeds from the illuminating center, excepting that portion of it which is transmitted through or reflected from the object." So likewise the value and character of the substage condenser was thoroughly understood and pointed out by him as follows: "I have no hesitation in saying that the apparatus for illumination requires to be as perfect as the apparatus for vision, and on this account I would recommend that the illuminating lens should be perfectly free of chromatic and spherical aberration, and the greatest care be taken to exclude all extraneous light both from the object and from the eye of the observer." See Sir David Brewster's treatise on the Microscope, 1837, pp. 136, 138, 146, and the Edinburgh Journal of Science, new series, No. 11 (1831) p. 83.

§ 101. **Achromatic condenser.** — It is still believed by all expert microscopists that the contention of Brewster was right, and the condenser to give the greatest aid in elucidating microscopic structure must approach in excellence the best objectives. That is, it should be as free as possible from spherical and chromatic aberration, and

therefore would transmit to the object a very large aplanatic cone of light. Such condensers are especially recommended for photo-micrography by all, and those who believe in getting the best possible image in every case are equally emphatic that achromatic condensers should be used for all work. Unfortunately good condensers like good objectives are expensive, and student microscopes as well as many others are usually supplied with the non-achromatic condensers or with none.

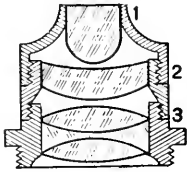

FIG. 39. ACHROMATIC SUBSTAGE CONDENSER.

(From Watson's Catalogue).

1, 2, 3 The lens elements making up the condenser. While the lenses are larger, the general construction of a substage condenser is like an objective, 1 representing the front, 2 the middle, and 3 the back combination of the objective.

Many excellent achromatic condensers have been made, but the most perfect of all seems to be the apochromatic of Powell and Lealand (Carpenter-Dallinger, p. 302). To attain the best that was possible many workers have adopted the plan of using objectives as condensers. A special substage fitting is provided with the proper screw and the objective is put into position, the front lens being next the object. As will be seen below (§ 106-107), the full aperture of an objective can rarely be used, and for histological preparations perhaps never, so that an objective of greater equivalent focus, i.e., lower power, is used for the condenser than the one on the microscope. It is much more convenient, however, to have a special condenser with iris diaphragm or special diaphragms so that one may use any aperture at will, and thus satisfy

the conditions necessary for lighting different objects for the same objective and for lighting objectives of different apertures.

§ 102. **Non-achromatic condensers.**—Of the non-achromatic condensers or illuminators, the Abbe condenser or illuminator is the one most generally used. From its cheapness it is also much more commonly used than the achromatic condenser. It consists of two or three very large lenses and transmits a cone of light of 1.2 N.A. to 1.40 N.A. (fig. 41, 46), but the aberrations, both spherical and chromatic, are very great in both forms. Indeed, so great are they that in the best form with three lenses and an illuminating cone of 1.40

N.A., the aplanatic cone transmitted is only 0.5, and it is the aplanatic cone which is of real use in microscopic illumination where details are to be studied. There is no doubt, however, that the results obtained with a non-achromatic condenser like the Abbe are much more satisfactory than with no condenser. The highest results cannot be attained with it, however.

§ 103. **Position of the condenser.** — The proper position of the illuminator for high objectives is one in which the beam of light traversing it is brought to a focus on the object. If parallel rays are reflected from the plane mirror to it, they will be focused only a few millimeters above the upper lens of the condenser; consequently the illuminator should be about on the level of the top of the stage and therefore almost in contact with the lower surface of the slide.

§ 104. **Determining whether the condenser is centered.** — For getting the best results the condenser should be centered to the optic axis

of the microscope; that is, the optic axis of the condenser and of the microscope should be along the same straight line. The simplest method of determining this point with any given objective is to get the microscope in focus on some very small or transparent object and then to look at the eye-point above the ocular with a magnifier. While looking at the eye-point close the iris diaphragm until the aperture of the objective is only partly filled. Now, if the circle of light appearing in the back lens is in the center, the condenser is centered. If it is not in the middle, then the condenser is not centered (fig. 43).

If the condenser has centering screws (fig. 40), it is very simple to adjust them until the circle of light appears in the center of the back lens. If centering screws are not provided and the condenser is badly decentered, the microscope should be sent to the makers for correction.

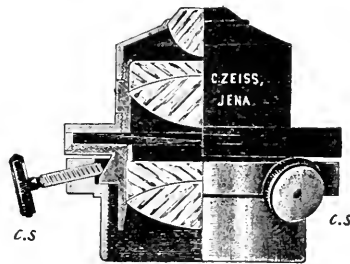

FIG. 40. ACHROMATIC SUBSTAGE CONDENSER WITH THE DIAPHRAGM BETWEEN THE COMBINATIONS.

(From the Catalogue of Zeiss).

c.s. Centering screws.

§ 105. **Testing the centering by slowly opening the diaphragm.** — After the condenser is centered as well as possible with the small diaphragm, one can test its centering rigidly by looking directly down the tube without the ocular or by looking at the eye-point with a magnifier and slowly opening the diaphragm. If it is accurately centered, the black ring will become narrower and disappear all around at the same time. If it is not accurately centered the black ring will open on one side. In case the condenser is not found centered, change its position slightly until the black ring disappears at the same time all around.

§ 106. **Numerical aperture of the condenser.** — As stated above, the aperture of the condenser should have a range to meet the requirements of all objectives from the lowest to those of the highest aperture. It is found in practice that for diatoms, etc., the best images are obtained when the object is lighted with a cone which fills about three-fourths of the diameter of the back lens of the objective with light, but for histological and other preparations of lower refractive power only one-half or one-third the aperture often gives the most satisfactory images.

To determine this in any case focus upon some very transparent object, take out the ocular, look down the tube at the back lens or look at the eye-point (fig. 22-24) with a magnifier. If less than three-fourths of the back lens is lighted, increase the opening in the diaphragm — if more than three-fourths, diminish it. For some objects it is advantageous to use less than three-fourths of the aperture. Experience will teach the best lighting for special cases.

§ 107. **Aperture and source of light.** — As shown by Brewster nearly a century ago, and as brought out in late years by Gordon and Wright, the amount of aperture giving the best results depends on the size of the source of light. In § 106 it was assumed that a large source was used like a window or door. If now a small source like the illuminated disc of daylight glass in the lantern for artificial daylight (fig. 37-38) is used, then considerably more of the aperture of the objective can be utilized without the fogging and loss of detail which results when using a large source like a window. It is also a fundamental fact that the larger the aperture utilized, the more details, and the more sharply are the details brought out in the specimen.

Use a 4 mm. or higher objective and demonstrate the truth of the above statements by looking at the same specimen, using the window as a source of light and note the aperture of the objective which gives the best effect. Then use one of the daylight lanterns, and increase the aperture by opening the diaphragm until the best image is obtained. Notice the detail sharply visible in the two cases.

107a. The remarks of Wright, *Principles of Microscopy*, p. 219, are so pertinent upon this point that they are here repeated:

"The necessity for the regulation of the source of illumination will appear when we consider the optical conditions which obtain where an extended radiant field such as is furnished by the sky or a broad lamp flame is employed as a source of light. There will be formed in such a case upon the stage of the microscope by the focused condenser an image of the light source which will extend beyond the limits of the field of view of any objective. From the radiant points included within this illuminated area beams will pass into the aperture of the objective. Those from the center of the field — always assuming that their numerical aperture does not exceed the numerical aperture of the objective — will pass through the aperture unmutated. It will be different with respect to the beams which proceed from the periphery of the field. These, taking the aperture obliquely, will, unless in the case where their numerical aperture is much less than that of the objective, be cut down in an unsymmetrical manner by the margin of the objective, exactly in the same way as would be the case if transmitted through an elliptical, or, in the extreme case, through a slit aperture.

"It follows that while the radiant points in the center of the field will be represented in the image by circular antipoints whose dimensions will be determined by the full numerical aperture of the objective, the radiant points on the periphery of the field will be represented in the image by elliptical or linear antipoints whose long axes will in each case be disposed radially to the aperture, overlapping the antipoints in the center of the field in such a manner as to fog the image."

EXPERIMENTS WITH THE CONDENSER AND ARTIFICIAL LIGHT

§ 108. **Kerosene lamp.** — Use a kerosene lamp with a flat wick. The wick should be from 3 to 5 cm. wide. For use, the flame is turned up well, but not high enough to smoke. Put the lamp 15 to 20 cm. from the microscope. Between the lamp and microscope should be a dark screen sufficiently high and broad to shade the microscope stage and to protect the eyes of the observer. The bottom of this screen should be high enough from the table to admit the light (fig. 33) or preferably it should have a hole from 5 to 10 cm. in diameter near its lower edge to admit the light from the lamp (fig. 58). The dark screen with the hole will serve also to hold the daylight glass (§ 92).

The greatest brilliancy comes by having the image of the lamp flame on the object and by having as great a thickness as possible of the flame toward the microscope.

With low powers the face of the flame must be toward the microscope in order to light the entire field, but with moderate powers it may be oblique, and with the highest powers the edge of the flame should face the microscope, as this utilizes the greatest thickness of the flame. Make sure that the flame is centered by moving the mirror or the lamp (fig. 44).

As the light is diverging from the lamp flame it is usually better to employ the concave mirror in order to overcome, in part, this divergence, and light a larger field. In some cases it may be necessary also to lower the condenser somewhat to get the entire field lighted. A gas lamp with an incandescent mantle gives good results, also an acetylene flame. Proceed in general as with the kerosene lamp.

§ 109. **Electric lamp.** — If an electric bulb is used it should be frosted for low powers; or what is better, a clear bulb should be used and a piece of ground-glass should be put over the hole in the screen between the lamp and the microscope (fig. 58). The lamp should be close to the ground-glass.

For moderate and high powers the ground-glass is excellent also. For lighting the entire field it may be necessary to use the concave mirror and also to lower the condenser.

For the highest powers a single filament of the incandescent lamp is focused on the object and carefully centered. For lighting the entire field lower the condenser slightly and thus spread the light (fig. 42).

Both mirrors should be tried alternately, also raising and lowering the condenser a small amount. One can thus find which arrangement gives the best possible results in difficult cases. While it may take some time to try the different things, in the long run it will pay in the satisfaction given by the more perfect image.

For the electric arc with the microscope see under drawing and photography (Chs. VI–VII).

§ 110. **Aperture and diaphragm.** — It is to be remarked that with a very small source of light the entire aperture of the objective may be

filled if a proper illuminator or condenser is used. This is because light rays go off from a light source in the form of a sphere, and even a point source would give light which would fill any aperture. The aperture in a given case depends on the diaphragm used with the condenser, and the size of the diaphragm must vary directly as the aperture of the objective. That is, it is just the reverse of the rule for diaphragms where no condenser is used (§ 89); for there the diaphragm is made large for low powers, and consequently low apertures, while with the condenser the diaphragm is made small for low and large for high powers, as the aperture is greater in the high powers of a given series of objectives. It is very instructive to demonstrate this by using a 16 mm. objective and opening the diaphragm of the condenser till the back lens is just filled with light. Then if one uses a 4 mm. objective it will be seen that the back lens of the higher objective is only partly filled with light and to fill it the diaphragm must be much more widely opened.

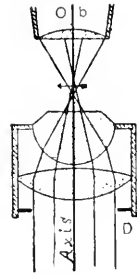

FIG. 41. SUBSTAGE CONDENSER OF ABBE WITH PARALLEL LIGHT.

Axis The principal optic axis of the condenser and objective (*Ob*).

The iris diaphragm (*D*) is below the condenser.

§ 111. **Mirror and light for the condenser.** —

It is best to use light with parallel rays. The rays of daylight are practically parallel; it is best, therefore, to employ the plane mirror for all but the lowest powers. If low powers are used the whole field is not illuminated with the plane mirror when the condenser is close to the object; furthermore, the image of the window frame, objects outside the building, as trees, etc., would appear with unpleasant distinctness in the field of the microscope. To overcome these defects one can lower the condenser and thus light the object with a diverging cone of light, or use the concave mirror and attain the same end when the condenser is close to the object (fig. 42).

§ 112. **Lighting the entire field with a condenser.** — With the condenser there are two conditions that must be fulfilled; the proper aperture must be used, and the whole field must be lighted. As seen in § 110 the diaphragm of the condenser regulates the aperture of the

illuminating cone, but has nothing to do with lighting a large or a small field. The size of field that is lighted by means of a condenser can be modified in two ways:

(1) Suppose that the image of the source of light is focused on the object, the size of that image will determine the size of field which is illuminated in a given case. If the illuminated field is not so large as the objective field, then the source of light is too small, or too far away. In that case use a larger source or bring the source closer to the microscope.

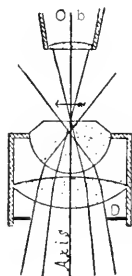

FIG. 42. SUB-STAGE CONDENSER WITH CONVERGING LIGHT.

Axis The principal optic axis of the condenser and the objective (*Ob*). The iris diaphragm (*D*) is below the condenser.

(2) By lowering the condenser or using the concave mirror a much larger object can be fully lighted, as it is in a diverging cone of light above the focal point of the condenser where the light is spread over a greater area (fig. 42).

For quite low objectives, 35 to 60 mm. focus, it is better to remove the condenser and use the mirror only. The whole field can be illuminated easily and sufficiently in this way.

§ 113. **Homogeneous immersion condenser** (Ch. IX). — For numerical apertures higher than 1.00 it is necessary to connect the under side of the microscopic slide with the top of the condenser with homogeneous immersion fluid. As the objectives used for high apertures are also

homogeneous immersion, there is no change in the direction of the light from the condenser until it reaches the objective, excepting diffraction effects, and the reflecting or refracting action of the specimen in the path of the rays. The special need of the homogeneous connection between the slide and the condenser comes from the laws of refraction. If there were not a homogeneous connection the most oblique rays, that is, those giving a numerical aperture above 1.00 with a solid cone of light, and the most oblique rays with a hollow cone of light, would meet the terminal surface of the condenser at an angle greater than the critical angle, $41^\circ+$, and would therefore be totally reflected as from the surface of a mirror, and the advantage

of the condenser be in part nullified (see Ch. IX for critical angle). By making the homogeneous connection between the slide and condenser, any light leaving the condenser passes on through the slide without change of direction, except any that may be given by the object.

The centering of the homogeneous immersion condenser is of prime importance, and practically all forms of them are supplied with centering screws for the purpose (fig. 40, § 104).

§ 114. **Use of artificial daylight.** — Place a piece of the daylight glass in the opening of the dark screen or lantern (fig. 37-38). If this daylight glass is lightly ground, it will diffuse the light without lowering its intensity too greatly.

If possible, use a 100 watt nitrogen-filled tungsten (mazda) concentrated filament lamp. Put the lamp within 5 to 10 cm. of the daylight glass. Use low and high powers and the various colored specimens that require daylight to bring out their color values. No matter how delicate the coloring or what the tint is, it will be as faithfully presented by the artificial daylight as by natural daylight. One can prove this by having the apparatus near a window, then the mirror can be turned toward the artificial or the natural daylight at will and the color effects can be compared.

By using the daylight glass with other artificial lights it will be seen that even those lights when filtered through this glass give remarkably good daylight effects.

§ 115. **Axial and oblique light with the condenser.** — To demonstrate the effect of the methods of illumination when a condenser is used, take any striking preparation like a diatom (*Pleurosigma angulatum*, for example); employ a 4 mm. objective. Being sure that

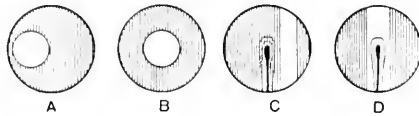

FIG. 43-44. CENTERING THE CONDENSER AND THE SOURCE OF LIGHT.

A The spot of light in the back combination of the objective at one side, showing that the condenser is not centered.

B The spot of light in the center, showing that the condenser is centered.

C The source of light is not in the middle.

D The source of light is centered and illuminates the object.

the condenser is centered, fill the aperture of the objective about $\frac{3}{4}$ full of light (§ 110). Study the preparation with the central light and note the appearance of the markings. Cover a part of the diaphragm opening by putting the finger or some other opaque object between it and the mirror (fig. 46). Note that the markings come out more strongly. Hold the finger in position and open the diaphragm widely and see if the markings can still be made out. Now remove the finger so that the object is lighted by the full aperture of central light. Probably the markings will not appear at all. Put the finger

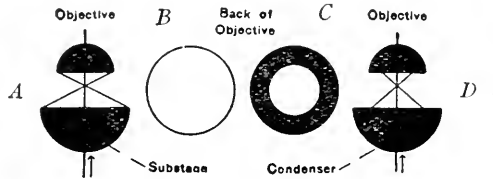

FIG. 45. APERTURE OF THE SUBSTAGE CONDENSER AND OF THE OBJECTIVE.
(From Nelson, Jour. Roy. Micr. Soc.).

A The cone of light from the condenser fills the aperture of the objective (*B*)
D The cone of light of the condenser only partly fills the aperture of the objective (*C*).

In *A* and *D* the condenser and objective are shown in section; in *B* and *C*, the back lens of the objective is shown in face view as when looking down upon it with the ocular removed.

back in position to give oblique light and the markings will again be seen. Remove the finger and slowly close up the diaphragm. When the proper aperture is reached the markings will again appear.

For histological preparations the oblique light is not a help in bringing out details of structure. There the end is reached by using the proper aperture, regulating the source of light, and by differential staining (Chs. X-XI).

§ 116. **Lateral swaying of the image.** — Frequently in studying an object, especially with a high power, it will appear to sway from side to side in focusing up or down. A glass stage micrometer or fly's wing is an excellent object. Make the light central or axial and focus up and down and notice that the lines simply disappear or grow dim.

Now make the light oblique, either by making the diaphragm opening eccentric or, if simply a mirror is used, by swinging the mirror sideways. On focusing up and down, the lines will sway from side to side. What is the direction of apparent movement in focusing down with reference to the illuminating ray? What in focusing up? If one understands the experiment it may sometimes save a great deal of confusion. (See under testing the microscope for swaying with central light, § 166.)

DARK-GROUND ILLUMINATION

§ 117. **Dark-ground illumination.** — By this is meant that form of illumination in which the object appears light and the background dark. The appearance is something like a series of bright objects in a dark night.

In order to be available for dark-ground illumination objects must be in a refracting medium different from themselves, and must have either strongly refracting or reflecting qualities.

The optical arrangements for this form of illumination must be such that the object is lighted by a beam of light which cannot get into the objective either because the rays are so oblique, or because they are cut out before reaching the eye. In either case the light on the background never reaches the eye. Only that which is reflected, refracted, or diffracted by the object reaches the eye. Consequently the appearance is of a bright object in a dark field.

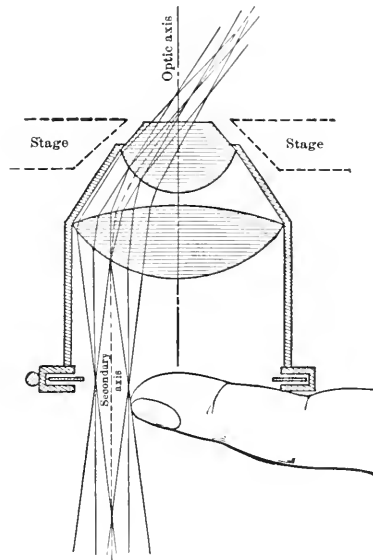

FIG. 46. OBLIQUE LIGHT WITH A CONDENSER.

(From Chamot).

The iris diaphragm is opened completely and the light from one side is blocked out by inserting the finger; this gives unsymmetrical light and all of it is oblique to the optic axis.

§ 118. **Dark-ground illumination by reflected light.** — This is the simplest method of getting the appearance of shining or white objects in a dark field. Use a 16 mm. or lower objective. For object use a glass slide with particles of lint, flour or starch, or other powder dusted on the slide. Put a piece of black velvet, or other dull black surface, over the opening in the stage and then put the slide in position. Place the microscope near a well-lighted window or use artificial light and let it shine on the slide. If now one looks into the microscope, the particles of dust on the slide will appear bright and the field will be dark. In the subsequent experiments (§ 119, 121) remember that the appearance may be due to light falling on top of the specimen, as here, and not that passing up from below. The top light can be eliminated by shading the stage with the hand or a black card.

§ 119. **Dark-ground illumination with transmitted light.** — Lower the condenser if one is present and swing it out to the side, or remove it and its mounting entirely, so that only the stage with its large opening remains.

Use a 16 mm. or lower objective. For object take a microscopic slide which has been standing face up for some time. It will be covered with fine dust. Or one can add a little dust, flour, starch, or other fine powder. Swing the mirror bar to the side away from the light, and then turn the mirror so that the light will strike the object very obliquely to the optic axis of the microscope (fig. 35). If the light is sufficiently oblique the dust particles will appear as shining specks on a dark background. Compare the appearance with that given by central light. Swing the mirror bar back in a vertical position, and reflect the light directly upward. Now the particles will appear black on a white field.

DARK-GROUND ILLUMINATION WITH THE CONDENSER

§ 120. Put the condenser back in place and close up under the stage. As with the mirror alone the light striking the object must be so oblique to the axis of the microscope that it will get into the objective only when reflected or refracted by the object. This may be accomplished in two ways.

§ 121. **By lighting from one side as with the mirror only.** — Use a 16 mm. or lower objective; for object, a glass slide with dust particles. Open the substage diaphragm to its full extent and reflect the light up through the condenser. The particles will now appear dark on a white field. Make the light unsymmetrical and very oblique by putting the finger in the path of the light on one side (fig. 46) and the field will be dark and the particles bright.

§ 122. **By lighting with a hollow cone.** — This lights the object with a ring of light, all the rays of which are very oblique (fig. 47).

For this use a 16 mm. objective and a slide with dust upon it as before. Open the substage diaphragm to its full extent, and turn the mirror so that the light is as brilliant as possible. Put a diaphragm with a ring opening in the holder under the substage. If now the object is looked at, the dust particles will shine in a dark field.

§ 123. **Dark-ground illumination by refraction.** — In the experiments already given for dark-ground effects the particles of dust have reflected the very oblique light into the microscope objective. The same effect may be produced by minute bodies refracting the very oblique light and thus turning part of it into the objective of the microscope. There are two cases:

(1) Objects whose refraction is less than the mounting medium: For this use air bubbles. Make a preparation by beating on a slide with a knife blade a small drop of gum arabic mucilage or other transparent viscid substance like saliva. This will include many air bubbles. Put the preparation under the microscope, using the 16 mm. or lower objective as before. Try an 8x or 10x ocular. Use the ring diaphragm and light as well as possible. The air bubbles will shine like globules of silver in a dark field. By focusing carefully the

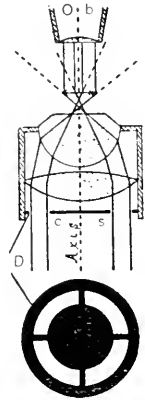

FIG. 47. DARK-GROUND ILLUMINATION BY A HOLLOW CONE OF LIGHT.

Axis The principal optic axis.

D The central stop (*cs*) or ring diaphragm cutting out all but the marginal rays of light, all of which are very oblique to the optic axis and will not enter the objective (*Ob*) unless deflected by the object.

image of the ring diaphragm will be seen in the air bubbles. The spherical air bubbles act like concave lenses in the surrounding medium of greater refractive power, and by changing the direction of the rays passing through them turn some of them into the objective, hence the appearance. If one uses saliva as liquid, the irregular gray bodies seen are epithelial cells from the mouth.

(2) Objects having a greater refractive power than the surrounding medium: Most objects studied belong to this group. For object use milk diluted four or five times with water or make an oil-globule preparation by beating in a large drop of water a small drop of oil. The oil globules are more refracting than the surrounding liquid, hence will act as convex lenses. But the difference in refraction is not so great as with air and water; hence the dark center will be wider and the bright ring narrower. One can also see the image of the ring diaphragm, but the central stop is relatively larger than with the air bubbles.

§ 124. **Infusoria with dark-ground illumination.** — A very striking and instructive preparation for dark-ground illumination may be made by taking water well supplied with living infusoria and other micro-organisms as object. These, under the microscope when properly lighted as indicated above (§ 123), appear like shining creatures swimming in black ink (§ 211).

DARK GROUND ILLUMINATION WITH HIGH POWERS

§ 125. For this a special condenser which gives a very oblique beam is required. The aperture of the objective must be rather low also; that is, less than 1.00. A numerical aperture not to exceed 0.95 will be found most satisfactory. For oil immersion objectives with their high numerical aperture (1.20-1.40) a diaphragm must be employed to reduce the aperture to less than 1.00 (fig. 48). The proper diaphragm is inserted by the manufacturers. With some objectives the diaphragm is easily inserted and removed by the observer, depending on his needs, but with some objectives only the manufacturer should insert and remove the reducing diaphragm. This involves either having a special oil immersion objective for dark-ground work, or being subjected to much inconvenience to have the

diaphragm inserted or removed. An alternative would be to use the objective for all work with the diaphragm in place, but the reduced aperture would make the resolution of fine details correspondingly less effective.

The principles involved in high power, dark-ground illumination and for the low-power work are the same, but for the high power work the light for the object must be more oblique or some of it would be at an angle which the large aperture of the objective would admit, and that would destroy the dark field, as the only light entering the objective should be sent to it by the reflecting, refracting, or dispersing action of the object. For all dark-ground work the light should be brilliant, and for high-power work it must be very brilliant. If sunlight is available, that is good. Of the artificial lights the small arc lamp (fig. 49) is most satisfactory. A concentrated filament nitrogen-filled mazda lamp of 100 or at most 250 watts is also good.

From the great obliquity of light required for high powers it is necessary to apply the immersion principle to the condenser, for if the light in the condenser is above 41° (the critical angle), it will not emerge from the terminal face of the condenser, but be totally reflected (Ch. IX). By adding the homogeneous immersion fluid between the condenser and the microscopic slide the light passes on directly without change to the object, and some of it is directed by the object to the objective. The slides should be 1 mm. or less in thickness so that the light can focus on the object. High powers with dark-ground illumination are much used at the present time in the study of living microbes; and in zoology, embryology, and histology it opens up a promising method of demonstrating minute granules in living things, the movement of cilia, amœboid movements of amœba, of leucocytes, and the Brownian movement of the granule, in leucocytes, salivary corpuscles, etc.

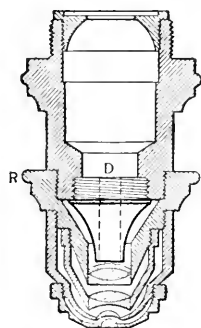

FIG. 48. HIGH-POWER OBJECTIVE WITH APERTURE REDUCING DIAPHRAGM FOR DARK-GROUND ILLUMINATION.

(From Chamot).

D Funnel-shaped reducing diaphragm screwed into the lower end of the "boot" opposite (*R*).

§ 126. Experiments with high powers and dark field. — Put the special dark-ground illuminator (fig. 50) in place of the condenser

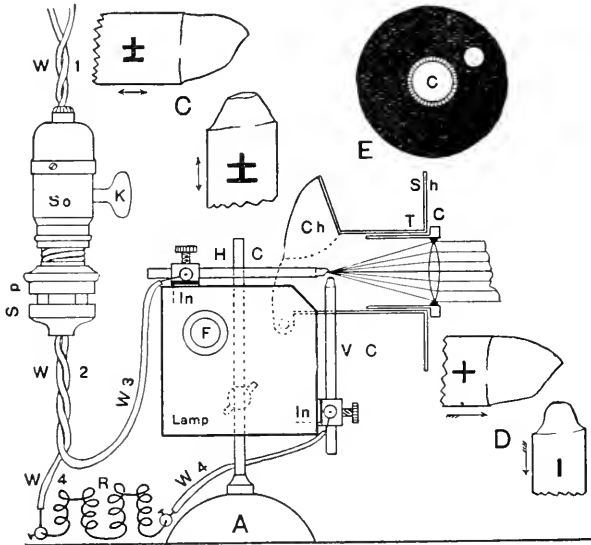

FIG. 49. SMALL ARC LAMP AND CONNECTIONS.
(From Optic Projection).

A Small arc lamp base with right-angle carbons (H C, V C) with insulation (In. In).

The arc and the condenser (C) are in position to give a parallel beam.

Ch Chimney over the arc, T, tube holding the condenser; sh, metal shield at the end of the condenser tube.

W₁ Wire cable to the lamp socket (So) with its key switch (K).

Sp Separable plug.

W₂, W₃ Wire to the upper or horizontal carbon (H C).

W₄ Wire to the rheostat (R) and to the lower or vertical carbon (V C).

C Tips of carbons for alternating current.

D Tips of carbons for direct current, the positive pole always being on the horizontal carbon (+), and the negative pole on the lower or vertical carbon (-).

E Shield at the end of the condenser tube; the face of the condenser is shown at (C).

ordinarily used. Push it upward in the sleeve so that it can be brought by the screw flush with the upper surface of the stage. Use a 16 mm.

objective and a 5x ocular for centering the condenser. For actual study the 10x ocular should be used also.

Focus down until the top of the condenser appears and one or two circles will be seen on the top of the condenser. If these circles are not in the center of the field, use the centering screws and get them in the center, that is, so that there will be an equal margin of the field all around.

§ 127. Slide, cover-glass, and specimen.

— Select a perfect and clean slide of the thickness required by the special condenser used. This varies with different makes from 1 to 1.5 mm. The thickness can be measured by a fine rule or by the cover-glass measurer (Ch. X). The reason for having the slide of a definite thickness that each condenser is designed to bring its very oblique light to a focus a definite distance above its face, and unless the slide is of the correct thickness the object will be too high or too low and thus be inadequately lighted.

It is best also to use a cover-glass of the correct thickness for the objective used (see Ch. IX). One 0.15 mm. thick will answer for almost all objectives.

For object use fresh unstained things like ciliated epithelium from the frog's mouth, fresh human or animal blood, saliva with some of the substance scraped from the teeth of some person, or some of the water and scrapings from the surface of the hay in a hay infusion (§ 211). The purpose in all of these preparations is to show fresh living things which move, and the structural details without staining, and in still living substance (see Ch. X for mounting).

Put on a cover-glass (fig. 70). Put a drop of homogeneous liquid on the top of the cover, and another drop on the slide immediately below or opposite the cover. Place the slide under the microscope.

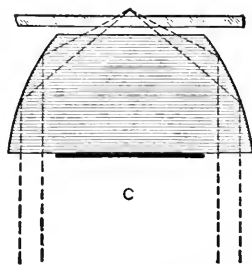

FIG. 50. CONDENSER FOR DARK-GROUND ILLUMINATION.

(Bausch & Lomb, from Chamot).

The illuminating beam is composed of parallel light, the central part being stopped out by the stop (C).

The slide must be of a thickness to admit of the focus on the objective just above it.

The condenser must be joined to the slide by water or homogeneous immersion fluid (see under Critical Angle).

This will bring the drop of homogeneous liquid on the lower side of the slide on the top of the condenser and will thus bring it in homogeneous contact. Now run the homogeneous immersion objective with aperture not above 1.00 down into the drop of liquid on the top of the cover.

§ 128. **Small arc lamp as radiant.** — If the small arc lamp is used, arrange its condenser (fig. 49) so that when the lamp is 25 to 50 cm. away the beam of light will almost cover the mirror. Use the plane mirror. Reflect the light up through the condenser. When the mirror is properly arranged the specimen will be brilliantly illuminated. Focus as usual with the fine adjustment. The objects should be of almost dazzling brilliancy in a dark field. Sometimes a slight readjustment of the mirror or of the centering will improve the appearance; and sometimes a slight elevation or depression of the condenser helps.

For continuous study it is less trying to the eyes if a piece of polished daylight glass is placed over the top of the ocular or held in some way in the path of the light on its way to the mirror. It renders the light bluish, however.

After using the dark-ground illuminator one will see the importance of using clean, perfect slides and cover-glasses. If any dirt or scratches are present they show with painful distinctness.

§ 129. **Mazda lamp as radiant.** — If the small arc lamp is not available, an incandescent, nitrogen-filled lamp of 100 or more watts makes a fairly good substitute. The best arrangement is to have the lamp in one of the lanterns for daylight glass (fig. 37-38). The frosted daylight glass should be removed and either no glass at all or polished daylight glass be used, as the ground-glass dims the light too much. Have the lantern close to the microscope, and reflect the light up through the condenser with the concave mirror as in ordinary observation (§ 96). This light serves very well for the homogeneous immersion objective and of course also for all the dry objectives.

§ 130. **Water immersion dark-ground condenser.** — For dry objectives and also for much of the work with the homogeneous immersion objective it suffices to use distilled water for connecting the slide with the condenser. This admits of an angle of $61^{\circ}+$ striking

the object (that is, in passing from the condenser to water the critical angle is $61^\circ + \text{Ch. IX}$), and this obliquity is sufficient for most purposes. Naturally it is easier to clean the water from the condenser and from the under side of the slide than to clean off the homogeneous liquid. For the most satisfactory work with the homogeneous objectives, however, it is better to use the homogeneous connection with the condenser and slide.

§ 131. **Ultramicroscopy.** — By this is meant the detection of very small particles by means of dark-ground illumination. The principle is exactly the same as for the dark-ground work already discussed, except that it is carried to the extreme limit by using the brightest light, — sunlight or the electric arc, — and the light rays are practically at right angles to the optic axis of the microscope. From this direction of the light it is evident that none of the rays can enter the microscope with even the widest apertured objectives unless the light is deflected by something in the field. The brilliant light so used renders minute particles luminous something as sunlight entering a small hole in a darkened room renders particles of dust luminous. The greater the angle between the optic axis of the microscope and the light reaching the object, the smaller can be the object which will be revealed. As this method of lighting rendered particles luminous and therefore visible that were invisible with the microscope as ordinarily used, the use of the microscope with this lighting has come to be called *Ultramicroscopy*.

Ultramicroscopy required very special apparatus to get successful results, and is not at present much used in ordinary biological study and investigations. The matter has been ably treated in Dr. Chamot's work on *Elementary Chemical Microscopy*, Ch. IV, and the reader is referred to that treatise for a full and satisfactory account.

§ 132. **Gordon's method for dark-ground illumination with high powers.** — This method as given by Wright has the advantage of utilizing the full aperture of the objective and of requiring a very small amount of inexpensive apparatus in addition to the regular microscopic outfit in the hands of every worker. The method is as follows:

The object is lighted by a solid cone of light from the condenser as usual, but the aperture of the condenser must only fill the middle

part of the aperture of the objective. In the first method the aperture of the condenser must be great and that of the objective moderate, while in this the reverse is the case, and the objective should have a large aperture and the condenser a moderate aperture. The solid cone of light used for illumination has some of its rays deflected by objects in the field so that they enter the marginal zones of the objective. To secure dark-ground illumination in this manner only these marginal rays are utilized for the image, and the central solid cone of light entering the objective must be eliminated. This is accomplished by placing a diaphragm or stop on the back lens of the objective of just the right size to cut out the central solid cone and allow the marginal rays to pass on to form the image. This gives fairly good results with all powers. The same may also be accomplished, as shown by Gordon, 1906, by using a stop in the eye-point or Ramsden circle (§ 57, fig. 22-24).

COLLATERAL READING FOR CHAPTER II

CARPENTER-DALLINGER. — *The Microscope and its Revelations.*

CHAMOT, E. M. — *Elementary Chemical Microscopy.*

SPITTA, F. J. — *Microscopy, the Construction, Theory and Use of the Microscope.*

WRIGHT, SIR A. E. — *Principles of Microscopy.*

CONRAD BECK'S Cantor Lectures of the Royal Society of Arts, 1907. (Dark-ground illumination.)

NELSON, E. M. — *The Substage Condenser, its History Construction and Management; and its Effect theoretically considered.* *Jour. Roy. Micr. Soc.*, vol. XI, 1891, pp. 90-105.

CHAPTER III

ADJUSTABLE AND IMMERSION OBJECTIVES; REFRACTION AND COLOR IMAGES; BINOCULAR MICROSCOPES; CARE OF THE MICROSCOPE; CARE OF THE EYES; WORK TABLES; TESTING THE MICROSCOPE; MARKERS AND MECHANICAL STAGES; ROYAL MICROSCOPICAL SOCIETY STANDARDS

§ 133. Apparatus and material for Chapter III.

1. Compound microscope with dry, water, and homogeneous immersion objectives.
2. Simple microscope.
3. Eye shade (fig. 56).
4. Shield for microscope and observer (fig. 33).
5. Slides and cover-glasses (Ch. X).
6. Pleurosigma (§ 115) and stained bacteria.
7. Histological specimens like muscle fibers, etc.
8. Cedar oil, xylene, chloroform, glycerin, and lens paper.
9. Binocular microscope.
10. Opaque objects like insects, feathers, etc.
11. Mounted fly's wing.
12. Markers, mechanical stages, colored shellac and camel's hair brush for pointers.

ADJUSTABLE, WATER AND HOMOGENEOUS IMMERSION OBJECTIVES

Experiments

§ 134. **Adjustment for objectives.** — As stated above (§ 31) the aberration produced by the cover-glass (fig. 51) is compensated for by giving the combinations in the objective a different relative position than they would have if the objective were to be used on uncovered objects. Although this relative position cannot be changed in unadjustable objectives, one can secure the best results of which the objective is capable by selecting covers of the thickness for which the objective was corrected. (See table, Ch. IX.) Adjustment may be made also by *increasing* the tube-length for covers *thinner* than the standard and by *shortening* the tube-length for covers *thicker* than the standard.

In learning to adjust objectives, it is best for the student to choose

some object, like Pleurosigma (§ 115), whose structure is well agreed upon, and then to practise lighting it, shading the stage and adjusting the objective, until the proper appearance is obtained. The adjustment is made by turning a ring or collar which acts on a screw and

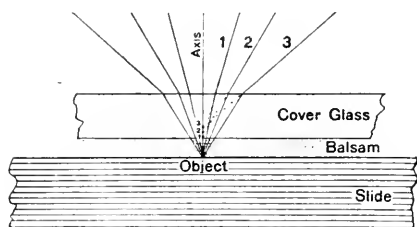

FIG. 51. ABERRATION PRODUCED BY THE COVER-GLASS.

Axis The extension of the principal optic axis.

Cover The cover-glass.

1, 2, 3 Three rays originating from the object mounted in balsam.

r, r, r Points of refraction as the three rays emerge from the upper surface of the cover into the air.

O Object from which the rays originate.

1, 2, 3 The three levels from which the rays seem to originate when traced backward from their points of emergence. This gives the effect of spherical aberration (Ch. IX).

increases the magnification of the objective (§ 235).

The following specific directions for making the cover-glass adjustment are given by Mr. Wenham (Carpenter, 7th Ed., p. 166): "Select any dark speck or opaque portion of the object, and bring the outline into perfect focus; then lay the finger on the milled-head of the fine motion and move it briskly backwards and forwards in both directions from the first position. Observe the expansion of the dark outline of the object, both when within and when without the focus. If the greater expansion or coma is when the object is without the focus, or farthest from the objective [i.e., in focusing up], the lenses must be placed further asunder, or toward the mark uncovered [the adjusting collar is turned toward the zero mark, as the cover-glass is too thin for the present adjustment]. If the greater expansion is when the

increases or diminishes the distance between the systems of lenses, usually the front and the back systems (fig. 35).

§ 135. Directions for adjustment. — (1) The thicker the cover-glass the closer together are the systems brought by turning the adjusting collar from the zero mark and conversely; (2) the thinner the cover-glass, the further must the systems be separated, i.e., the adjusting collar is turned nearer the zero or the mark "uncovered." This also in-

object is within the focus, or nearest the objective [i.e., in focusing down], the lenses must be brought closer together, or toward the mark covered [i.e., the adjusting collar should be turned away from the zero mark, the cover-glass being too thick for the present adjustment]." In most objectives the collar is graduated arbitrarily, the zero (o) mark representing the position for uncovered objects. Other objectives have the collar graduated to correspond to the various thickness of cover-glasses for which the objective may be adjusted. This seems to be an admirable plan; then if one knows the thickness of the cover-glass on the preparation (Chs. IX-X) the adjusting collar may be set at a corresponding mark, and one will feel confident that the adjustment will be approximately correct. It is then only necessary for the observer to make the slight adjustment to compensate for the mounting medium or any variation from the standard length of the tube of the microscope. In adjusting for variations of the length of the tube from the standard it should be remembered that: (1) If the tube of the microscope is longer than the standard for which the objective was corrected, the effect is approximately the same as thickening the cover-glass, and therefore the systems of the objective must be brought closer together, i.e., the adjusting collar must be turned away from the zero mark. (2) If the tube is shorter than the standard for which the objective is corrected, the effect is approximately the same as diminishing the thickness of the cover-glass, and the systems must therefore be separated (fig. 35), i.e., turned toward the zero mark.

In using the tube-length for cover correction shorten the tube for too thick covers, and lengthen the tube for too thin covers.

Furthermore, whatever the interpretation by different opticians of what should be included in tube-length, and the exact length in millimeters, its importance is very great, for each objective gives the most perfect image of which it is capable with the tube-length for which it is corrected, and the more perfect the objective the greater the ill-effects on the image of varying the tube-length from the standard. The plan of designating exactly what is meant by tube-length and engraving on each objective the tube-length for which it is corrected, is to be commended, for it is manifestly difficult for each worker

with the microscope to find out for himself for what tube-length each of his objectives was corrected (see Ch. IX).

§ 136. **Water immersion objectives.** — Put a water immersion objective in position (§ 44) and the fly's wing for object under the microscope. Place a drop of distilled water on the cover-glass, and with the coarse adjustment lower the tube till the objective dips into the water, then light the field well and turn the fine adjustment one way and another till the image is clear. Water immersions are exceedingly convenient in studying the circulation of the blood, and for many other purposes where aqueous liquids are liable to get on the cover-glass. If the objective is adjustable, follow the directions given in § 135.

When one is through using a water immersion objective, remove it from the microscope and with some lens paper wipe all the water from the front lens. Unless this is done dust collects and sooner or later the front lens will be clouded. It is better to use distilled water to avoid the gritty substances that are liable to be present in natural water, as these gritty particles might scratch the front lens.

REFRACTION AND COLOR IMAGES

§ 137. **Refraction images are those mostly seen in studying microscopic objects.** — They are the appearances produced by the refraction of the light on entering and on leaving an object. They therefore depend (a) upon the form of the object, (b) upon the relative refractive powers of object and mounting medium. With such images the diaphragm should not be too large (see § 106-107).

If the color and refractive index of the object were exactly like the mounting medium, it could not be seen. In most cases both refractive index and color differ somewhat; there is then a combination of color and refraction images which is a great advantage. This combination is generally taken advantage of in histology. The air bubble in § 194 is an example of a purely refractive image.

A purely refractive image like that given by an air bubble or a fat globule gives a dark border for central transmitted light, and a light border on a black field with very oblique light, such as is given by the mirror turned far to one side or by a central stop when the condenser

is used (§ 123, 201). In both cases the object is in outline. As pointed out by Wright (p. 5, 41) the visibility of the object shown in outline depends on the width of the outline and not on the diameter of the whole object. If the width of the outline is too narrow to include the necessary visual angle of 1 minute (§ 227) the whole object fades into the background and is no longer visible. On the other hand, if the object is colored, then it is visible so long as its entire diameter gives a visual angle of 1 minute or more.

One can see from the above what a tremendous advantage it is in studying the finest details of structure to have them brilliantly colored.

HOMOGENEOUS IMMERSION OBJECTIVES

Experiments

As stated above (§ 25), these are objectives (fig. 21B) in which a liquid of the same refractive index as the front lens of the objective is placed between the front lens and the cover-glass.

§ 138. **Refraction images.** — Put a 2 mm. homogeneous immersion objective in position; employ a condenser. Use some histological specimen like a muscular fiber as object; make the diaphragm opening about 9 mm. in diameter, add a drop of the homogeneous immersion liquid, and focus as directed in § 72. The object will be clearly seen in all its details by the unequal refraction of the light traversing it. The difference in color between it and the surrounding medium will also increase the sharpness of the outline. If an air bubble preparation (§ 195) were used, one would get pure refraction images.

§ 139. **Color images.** — Use some stained bacteria as *Bacillus tuberculosis* for object. Put a drop of the immersion liquid on the cover-glass or on the front lens of the homogeneous objective. Remove the diaphragms from the illuminator or in case the iris diaphragm is used, open it to its greatest extent. Focus the objective down so that the immersion fluid is in contact with both the front lens and the cover-glass; then with the fine adjustment get the bacteria in focus. They will stand out as clearly defined colored objects on a bright field.

If one closes the diaphragm until $\frac{1}{2}$ or $\frac{3}{4}$ of the aperture of the objective is used, the image will be a combined color and refraction image.

§ 140. **Shading the object.** — To get the clearest image of an object no light should reach the eye except from the object. A handkerchief or a dark cloth wound around the objective will serve the purpose. Often the proper effect may be obtained by simply shading the top of the stage with the hand or with a piece of card-board. Unless one has a very favorable light the shading of the object is of the greatest advantage, especially with the homogeneous immersion objectives. The shield (fig. 33) is the most satisfactory means for this purpose, as the entire microscope above the illuminating apparatus is shaded. This screen also shades the face of the observer.

§ 141. **Cleaning homogeneous objectives.** — After one is through with a homogeneous objective, it should be carefully cleaned as follows: Wipe off the homogeneous liquid with a piece of the lens paper (§ 158); then if the fluid is cedar oil, wet one corner of a fresh piece in xylene, or chloroform, and wipe the front lens with it. Immediately afterward wipe with a dry part of the paper. The cover-glass of the preparation can be cleaned in the same way. If the homogeneous liquid is a glycerin mixture proceed as above, but use water to remove the last traces of glycerin.

BINOCULAR MICROSCOPES

§ 142. For a binocular arrangement which shall be equally good for all powers up to and including the highest oil immersion, the following fundamental requirements must be met:

1. The light to each eye should be of equal intensity.
2. The optical path of the light to each eye should be of the same length, so that the magnification of the two images will be the same.
3. The numerical aperture should not be cut down or disturbed in any way.
4. The diffraction effects should be the same as for the monocular microscope.
5. The oculars must be laterally adjustable for the pupillary distance of different observers.

6. Pairs of oculars of different powers should be usable, for example a pair of 5x, a pair of 10x oculars, etc., that is, the oculars should not need to be special and should not be limited to one set.

7. It should be possible to focus one tube independently to compensate for difference in the two eyes of the observer.

8. It should be possible to focus the entire microscope with one coarse and one fine adjustment as for monocular instruments.

9. The tubes may converge so that the axes of the eyes will be directed to the near point of vision (250 mm.).

10. The tubes may be parallel, then the axes of the eyes will be parallel as for looking at distant objects.

§ 143. Very early in the history of the telescope and of the compound microscope, as nature has endowed us with two eyes, it was insisted upon that both eyes should be used in examining objects instead of using only one eye. This required two similar microscopes or telescopes side by side and the right distance apart for the two eyes. There still persists in the common opera-glasses the original binocular Dutch telescope-microscope.

The modern binocular dissecting microscope with two tubes and two objectives and two oculars is in principle like the original binocular microscope of Cherubin d'Orleans (1677), except, of course, the earlier one had no erecting arrangement.

The double microscope with two complete tubes, two objectives, and two oculars is not available for high powers, for the two objectives cannot be close enough together to bring the exceedingly small object into the field of both microscopes at the same time. Naturally, therefore, an effort was made to use a single objective and to divide the light passing through it so that half should go to the right and half to the left eye. The first successful binocular of this kind was invented by Riddell of New Orleans in America in 1851. In this, four prisms are used just above the objective and serve to divide the light equally and to pass it on to the two eyes through two parallel tubes, each with its own ocular. Later a satisfactory form was invented by Mr. Wenham of England in which there is but a single prism (fig. 52). Neither of these forms permitted of very high powers. Finally, in 1864, Mr. Robert B. Tolles invented a binocular, stereoscopic eye-

piece for use on any monocular microscope. The prisms divided the light equally and it was sent up through tubes parallel with the main

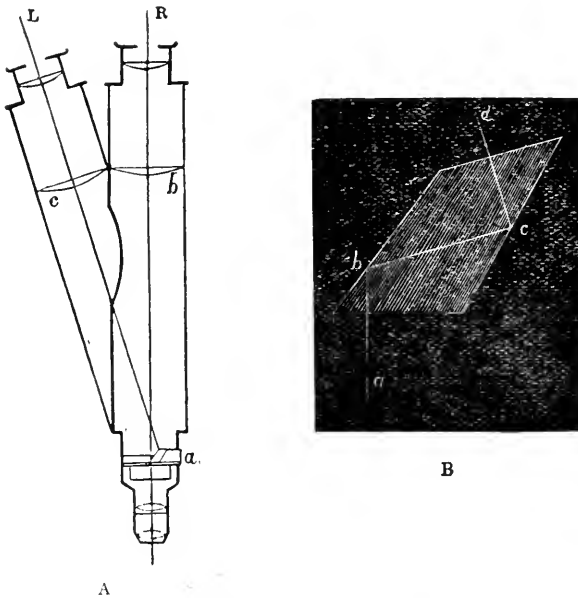

FIG. 52. WENHAM'S BINOCULAR MICROSCOPE.

(From Carpenter).

A Section of the microscope with the two converging tubes. By pulling out the draw-tubes the oculars are separated for the correct pupillary distance of each observer.

L R The axes of the left and right tubes.

a The prism which divides the light from the object.

c b The field lenses of the two oculars.

B Enlargement of the dividing prism.

a, b, c, d Path of the light in the prism for the left eye.

As shown, the light to the right eye extends straight upward. This arrangement is limited to rather low powers.

tube of the microscope, but, of course, separated the proper distance for the two eyes. In the words of President F. P. Barnard of Columbia College, New York, "This binocular eye-piece works with objectives of all powers with perfect equality of illumination in both fields."

While more or less successful efforts had long been made to produce binocular microscopes with a single objective, the optical requirements

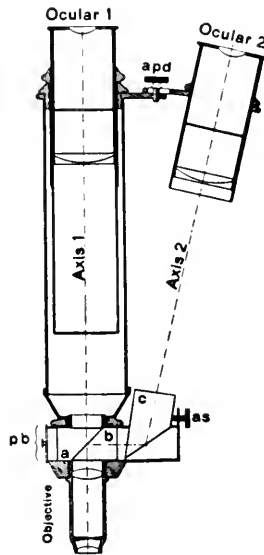

FIG. 53. IVES BINOCULAR ARRANGEMENT FOR ALL POWERS.

(Journal of the Franklin Institute, Dec. 1902).

Objective The single objective.

pb The prism box at the lower end of the tube.

a, b, c The prisms dividing the light equally from each point to the two eyes.

a, b The transparent silvered surface in the prism allowing half the light to pass through and half to be reflected to the right.

c Prism at the right reflecting the light upward to the right eye, *as*, adjusting screw to tilt the prism *c*, at the correct angle for the position of the right ocular.

apd Adjustment for the pupillary distance.

Ocular, 1, Ocular 2 The oculars for the right and the left eye.

Axis 1 The principal optic axis for the left eye.

Axis 2 The principal optic axis for the right eye.

Due to the length of the prism *c*, this axis is optically of the same length as *Axis 1* for the left eye.

were not fully grasped. Recently, however, Mr. Frederic E. Ives has stated the optical principles with great clearness, and shown how binocular microscopes using a single objective can be constructed.

(Ives, *Jour. Franklin Institute*, Dec. 1902, pp. 441-445, fig. 53.) See also the paper by Conrad Beck, with figures of the various forms of dividing prisms of binoculars, *Jour. Roy. Micr. Soc.*, 1914, pp. 17-23 (fig. 54, 55).

All single-objective binocular microscopes now on the market are made in accordance with the principles enunciated in Mr. Ives' original paper.

§ 144. **Parallel or converging tubes for binoculars.** — As mentioned above, the original telescope-microscope, persisting in the form of the opera-glass, had parallel tubes. Following the differentiation of the telescope and microscope in which the objective of the microscope gradually became of smaller diameter and shorter focus, and the eye-piece of the original, concave Dutch form was replaced by the convex, Keplerian form (see history at the end), the two objectives of the binocular could be placed closer together, and in this way smaller and smaller objects could be brought into the same field even with quite high objectives. As the oculars must be separated sufficiently to bring their axes in the middle of the pupil of the eye, the tubes must be made more or less converging (fig. 52).

The question is, which arrangement, parallel or converging tubes, is easiest on the eyes of the observer for continuous work. The argument of those advocating the parallel arrangement is that when the eyes are at rest, as in viewing distant objects, the rays entering the eyes are practically parallel, and the two eye axes are of course also parallel; and that with the most favorable focus of the microscope the rays of light leaving the oculars are practically parallel, hence the eyes should have their axes parallel as for viewing distant objects, and that there is no effort at accommodation for getting the sharpest image on the retina.

For those who advocate converging tubes it is pointed out that in observing small details the eye naturally uses the near point of distinct vision, viz. 250 mm. for adults, and not the far point, and therefore the most satisfactory microscopic work can be accomplished with the converging tubes to correspond with the natural convergence of the eyes. Much actual experience will doubtless be required for the settlement of the question. From the author's experience with the

monocular microscope, it seems that the argument that the eye should be in a condition of rest and not of accommodation when doing microscopic work, that is, the argument for the parallel tubes, seems convincing. Perhaps the Yankee spirit of compromise will be found most

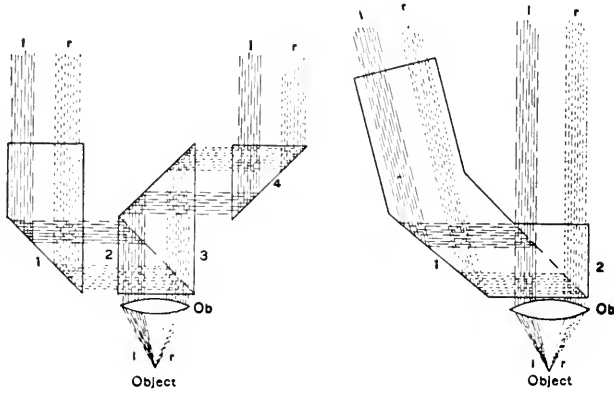

FIG. 54-55. PRISM ARRANGEMENT FOR TWO FORMS OF BINOCULARS FOR ALL POWERS.

(Conrad Beck, Jour. Roy. Micr. Soc. 1914).

In fig. 54 the arrangement is for parallel tubes, and in fig. 55 for converging tubes.

Object The object.

Ob The objective.

l, r; l, r The right and left beams of light emanating from the same point of the object.

As these beams extend through the objective and into the prisms they are equally divided so that half the right beam goes to the left and half to the right eye, and so with the left beam. This is indicated by the heavy and light broken lines by which the two beams are indicated.

1, 2, 3, 4; 1, 2 The four prisms in fig. 54, and the two prisms in fig. 55. The prisms are of the necessary length to make the optical path of the light equal for the two tubes, hence the magnification is equal for the two eyes.

truly practical in this matter and the binocular tubes of the future will be neither parallel nor too convergent.

§ 145. **Dissecting spectacles.** — Various devices have been produced from time to time to connect directly in some way with the eye. The long-used watchmaker's or jeweler's eye glass is the most familiar example, and answers fairly well, although for most dissecting work it

is more satisfactory to have the magnifier held by some mechanical means like the focusing holder shown in fig. 19.

The advantage of using both eyes has led to the production of binocular arrangements to be held in place by a band around the head. These are necessarily rather expensive.

The needs were stated to Dr. A. C. Durand in 1913, and at my request he devised a pair of spectacles which magnified approximately 1.5 diameters. In addition to the magnifying curve he added the correction for astigmatism, and combined these corrections and curves with a 4 degree prism, base in, to "relieve the excessive convergence which would otherwise be necessary with such short focus spheres." With these spectacles, which are much cheaper than any device on the market, and which have all the corrections needed for the eyes of the individual observer, it is very easy to carry on minute dissection. The prisms serve to prevent the weariness which comes so soon with great convergence. The eyes look nearly straight ahead, as in viewing distant objects, and are therefore in position of rest. These spectacles have also been found of much service in reading proof of fine print.

EXPERIMENTS WITH BINOCULAR MICROSCOPES

§ 146. **Erecting, double-objective binocular.** — Put a pair of objectives of 40 to 50 mm. focus, and a pair of oculars, 4x or 5x, in place. The oculars are put in place in the ordinary manner (§ 45), but the objectives are now often mounted in a sliding objective changer permanently. To put them in place one has simply to slide the pair in the mounting into the proper groove at the lower end of the microscope body.

Place the microscope where a good light can be had and put on the stage some transparent specimen like an organ with the blood vessels injected or with both the blood and the lymphatic vessels injected. Reflect the light up through the specimen, and focus.

§ 147. **Arranging the microscope for binocular vision.** — Until one has had some experience with binocular microscopes it is not easy to tell whether one is seeing with one eye or with both. In order to see with both eyes it is of course necessary that each eye should receive the beam of light from its own ocular at the same time, and this can

occur only when the oculars are spread the right amount to bring the eye-points the same distance apart as the pupils of the eyes of the observer, and the eyes are at the correct level.

Hold the head close to the oculars and look into the microscope. Focus as usual and the image will be satisfactory. Now to tell whether the image is seen with one eye or with both, hold the head still and shut the eyes alternately. If only one eye is being used no image at all will be seen when that eye is closed, but when the other is closed there will be no change in the appearance (§ 147 a).

If it is found that only one eye is being used, change the spread of the oculars by grasping the prism holder or drums or the tubes above these with the two hands and increase and diminish the distance between the tubes until both eyes are receiving the light, and there is an image in each eye. When this occurs and one once gets the stereoscopic effect there will never be any doubt in the future whether the vision is monocular or binocular.

§ 147a. In some makes of binocular microscopes (the Spencer Lens Co.'s, for example), there is a little shutter just above the objectives which can be turned to either side, covering the back of the corresponding objective. If the image is still apparent whichever objective is covered then of course both eyes are seeing the image, but if the image is wholly obliterated when the shutter is on one side, that is the only side giving an image, and the tubes must be changed in position to get the correct pupillary distance of the eye-points.

§ 148. **Focusing if the eyes are unlike.** — It occasionally happens that the eyes of the observer are markedly different. Provision is made for focusing one tube or one objective to compensate for this. If it is necessary to make this special adjustment, focus first with the rack and pinion and get the focus as sharp as possible for the tube having no special adjustment; then, without changing the general focus, turn the milled ring of the other tube until the image for the corresponding eye is also perfectly sharp. If now one uses both eyes the images should be equally sharp and the binocular vision good.

Of course the lower the objective the less need there is for special adjustment.

§ 149. **Opaque objects for the double-objective binocular.** — Put a piece of black paper or velvet on the stage, and upon that a piece

of white cloth, a light-colored insect, a feather, or any other object which it is desired to see. Place the microscope where there is a good light and look at the object. When seeing with both eyes the stereoscopic effect will be very striking, and one can see the different levels, etc., as with the naked eye.

For dissecting and for dark objects the lighting must be brilliant. Sunshine on the specimen is often none too strong, but as that is not stationary and not to be had at all times, it is usually more satisfactory to use a small arc lamp (fig. 49) or a projector with a concentrated or stereopticon type mazda lamp. If the light is concentrated upon the mirror for translucent specimens or directly upon the opaque specimens there will be sufficient light to give satisfactory images.

§ 149a. Correct movement of the specimen or instruments under an erecting microscope. — For one who has become thoroughly trained in using the ordinary inverting compound microscope it is very difficult to make the proper motions to move the specimen, or to move the dissecting instruments correctly under an erecting compound microscope. This illustrates the power of training. The beginner with the inverting microscope finds it hard to move his hands in the opposite way from what his eyes dictate, but when the correlation between the appearance and the motion necessary has become fixed, it is equally difficult to move the hands in the direction which the eyes indicate, although it is known that this is now correct. This difficulty is soon overcome by practice.

Under the simple microscope, however, in which there is no reversal or inversion, the eyes and hand work together automatically as with the naked eye.

SINGLE-OBJECTIVE BINOCULAR MICROSCOPES FOR ALL POWERS

§ 150. Single-objective binoculars. — This is to be used for looking at microscopic specimens exactly as a monocular compound microscope. That is, the lighting, numerical aperture of the condenser, and all the work done with it is the same. The only difference is that the two tubes are to be arranged at the right distance apart to give binocular vision as discussed in § 147.

If the two eyes differ, then one of the tubes must be focused to make the necessary compensation.

With the excellent binoculars now available, there is nothing done with the monocular microscope that cannot be done with the binocular, and for many workers the use of the two eyes, as has been so long contended by the English microscopists, gives much relief for long-

continued observation. The stereoscopic appearance, while desirable in some cases, is not of very much advantage in revealing structure when working with high powers.

§ 151. **Experiments with single objective binoculars.** — So far as the lighting is concerned it is exactly as for a monocular microscope (§ 83-130).

§ 152. Arrange the microscope in a convenient position, use any pair of oculars (5x or 10x) and any objective, but to begin with a low-power (16 mm.) objective is to be preferred. Use a preparation like the mounted fly's wing or a preparation showing injected blood vessels. Look into the microscope and arrange the light so that the object is well illuminated. The determination of binocular vision is exactly as with the double-objective binocular (§ 147).

§ 153. **Pupillary distance.** — To vary the distance of the eye-points for converging tubes rotate the oculars equally up from the lowest point until the binocular effect is secured, and then note the position of the oculars. If the tubes are parallel there is a screw between them by which they can be separated or approximated. Continue to adjust until the binocular vision is perfect and then note the position so that the tubes can be set in the right position instantly at some future time. Each individual must determine the pupillary distance of his own eyes. The chances are against any two persons being alike in that respect.

§ 154. **Unlikeness of the two eyes.** — With many persons the refraction of the two eyes is somewhat different, so that if the microscope is in focus for one eye it is necessary to refocus for the other. Now if this is the case it is necessary to focus the two tubes differently in a binocular. Focus first with the tube which is not adjustable for parallel tubes, or with either one where converging tubes are used. Then close the eye used for focusing first and focus the other tube for the other eye by rotating the tube up or down until the image is sharp, or by turning the milled ring in the adjusting tube of the parallel tube type. If one now looks into the microscope with both eyes there will be two sharp images fused.

CARE OF THE MICROSCOPE

§ 155. The microscope should be handled carefully and kept perfectly clean. The oculars and objectives should never be allowed to fall.

When not in use keep it in a place as free as possible from dust.

All parts of the microscope should be kept free from liquids, especially from acids, alkalis, alcohol, xylene, turpentine, and chloroform.

§ 156. **Care of the mechanical parts.** — To clean the sliding mechanical parts put a small quantity of some fine oil (olive oil or liquid vaselin and gasoline or xylene, equal parts) on a piece of gauze, chamois leather, or lens paper, and rub the parts well; then with a clean dry piece of the cloth chamois or paper wipe off most of the oil. If the mechanical parts are kept clean in this way a lubricator is rarely needed. When opposed brass surfaces "cut," i.e., when from the introduction of some gritty material, minute grooves are worn in the opposing surfaces, giving a harsh movement, the opposing parts should be separated, carefully cleaned as described above, and any ridges or prominences scraped down with a knife. Where the tendency to "cut" is marked, a very slight application of equal parts of beeswax and tallow, well melted together, serves a good purpose. The thick fibrous grease such as is used in the grease cups of automobiles is also good.

In cleaning lacquered parts, xylene alone answers well, but it should be quickly wiped off with a clean piece of the lens paper. Do not use alcohol, as it dissolves the lacquer.

§ 157. **Care of the optical parts.** — These must be kept scrupulously clean in order that the best results may be obtained.

Glass surfaces should never be touched with the fingers, for that will soil them.

Whenever an objective is left in position on a microscope, or when several are attached by means of a revolving nose-piece, an ocular should be left in the upper end of the tube to prevent dust from falling down upon the back lens of the objective (§ 157a).

§ 157a. As pointed out by Wright, p. 93, one of the surest ways to detect anything wrong with the objective is to examine the eye-point with a magnifier.

The field should be lighted well and the aperture of the objective filled about $\frac{2}{3}$ full of light. If there are any defects as smears of balsam or liquids on the front lens, unsealing of the combinations, or dust on the upper face of the back lens the defect can be seen in the eye-point.

Another and very certain method of detecting imperfections is to rotate the different elements while looking into the microscope. If the defect is in the mirror they will change in position when the mirror is moved, and so with all the other elements. Defects in the ocular are strikingly shown by rotating it.

§ 158. **Lens paper.** — The so-called Japanese filter paper, which, from its use with the microscope, I have designated lens paper, has been used in the author's laboratory since 1885 for cleaning the lenses of oculars and objectives, and especially for removing the fluid used with immersion objectives. Whenever a piece is used once it is thrown away. It has proved more satisfactory than cloth or chamois, because dust or sand is not present; and from its bibulous character it is very efficient in removing liquid or semi-liquid substances.

§ 159. **Removal of dust, etc.** — (1) Dust may be removed with a camel's hair brush, or by wiping with the lens paper.

(2) Cloudiness may be removed from the glass surfaces by breathing on them, then wiping quickly with a soft cloth or the lens paper.

Cloudiness on the inner surfaces of the ocular lenses may be removed by unscrewing them and wiping as directed above. A high objective should never be taken apart by an inexperienced person.

If the cloudiness cannot be removed as directed above, moisten one corner of the cloth or paper with 95% alcohol, wipe the glass first with this, then with the dry cloth or the paper.

(3) Water may be removed with soft cloth or the lens paper.

(4) Glycerin may be removed with cloth or lens paper saturated with distilled water; remove the water as above.

(5) Blood or other albuminous material may be removed while fresh, the same as glycerin. If the material has dried on the glass, it may be removed more readily by adding a small quantity of ammonia to the water in which the cloth is moistened (water 100 c.c., ammonia 1 c.c.).

(6) Canada Balsam, damar, paraffin, or any oily substance may be removed with a cloth or paper wet with chloroform, gasoline or xylene. The application of these liquids and their removal with a

soft dry cloth or lens paper should be as rapid as possible, so that none of the liquid will have time to soften the setting of the lenses.

(7) Shellac Cement may be removed by the paper or a cloth moistened in 95% alcohol.

(8) Brunswick Black, Gold Size, and all other substances soluble in chloroform, etc., may be removed as directed for balsam and damar.

In general, use a solvent of the substance on the glass and wipe it off quickly with a fresh piece of the cloth or lens paper.

It frequently happens that the upper surface of the back combination of the objective become dusty. This may be removed in part by a brush, but more satisfactorily by using a piece of the lens paper loosely twisted. When most of the dust is removed some of the paper may be put over the end of a pine stick (like a match stick) and the glass surfaces carefully wiped.

CARE OF THE EYES

§ 160. Keep both eyes open, using the eye-shade if necessary (fig. 56), and divide the labor between the two eyes, using one eye for a

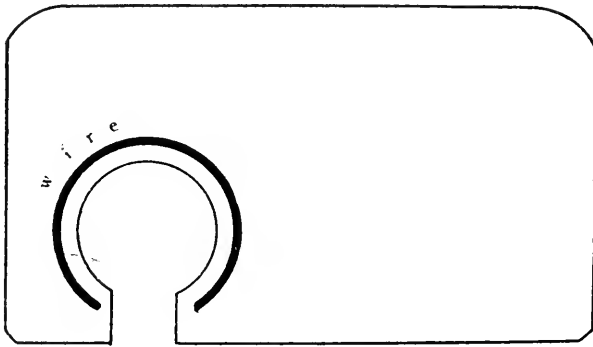

FIG. 56. EYE-SHADE FOR THE TOP OF THE MICROSCOPE TO ENABLE THE OBSERVER TO KEEP BOTH EYES OPEN.

while and then the other. It frequently happens that one eye is much more perfect than the other, then of course the more perfect eye is used all the time.

The binocular microscope has certain advantages in that one uses both eyes all the time as in naked-eye observation. If a binocular is used, however, one must adjust it accurately so that each eye sees an equally sharp image (§ 154).

§ 161. In the beginning it is not advisable to look into the microscope continuously for more than half an hour at a time. One never

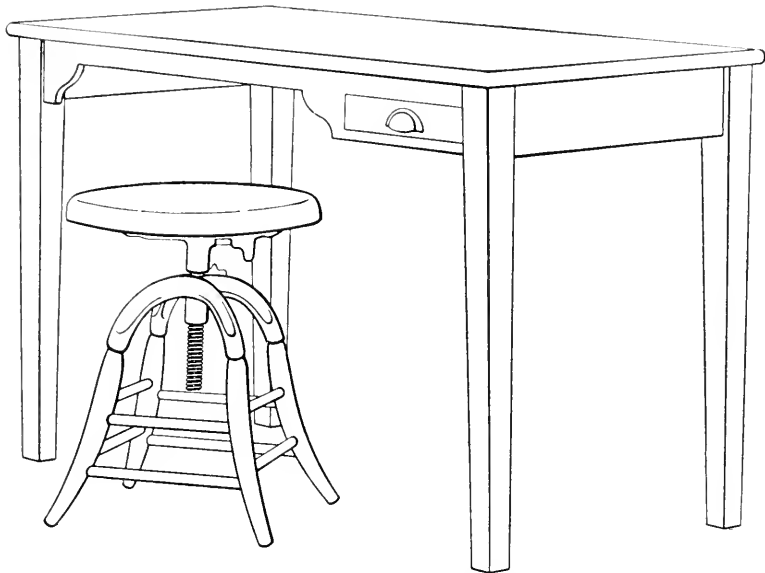

FIG. 57. LABORATORY TABLE AND ADJUSTABLE STOOL.

This table is 122 cm. long, 61 cm. wide, and 73 cm. high (2 × 4 feet on top, and 29 inches high).

The corners and edges are rounded and the top is stained with aniline black. The front of the rail is cut out, and the drawer is at the right so that it can be opened without moving the stool.

should work with the microscope after the eyes feel fatigued. After one becomes accustomed to microscopic observation he can work for several hours with the microscope without fatiguing the eyes. This is due to the fact that the eyes become inured to labor like the other organs of the body by judicious exercise. It is also due to the fact that but very slight accommodation is required of the eyes, the eyes

remaining nearly in a condition of rest as for distant objects. The fatigue incident upon using the microscope at first is due partly at least to the constant effort on the part of the observer to remedy the defects of focusing the microscope by accommodation of the eyes. This should be avoided and the fine adjustment of the microscope

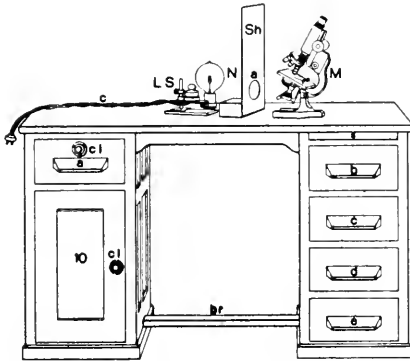

FIG. 58. MICROSCOPICAL LABORATORY DESK.

(Designed by Dr. V. A. Moore.)

The size of the top and the height are the same as for the laboratory table (fig. 57).

At the right there is a cabinet with combination lock (*10*, *cl*) for a microscope, and above a drawer with combination lock (*cl*).

At the right is a writing shelf (*s*) and four drawers.

Near the bottom is a brace (*br*) which also serves as a foot rest. (*M*), (*c LS*), (*Sh*), (*a*), a microscope, a lamp and a shield with daylight glass in the aperture.

used instead of the muscles of accommodation. With a microscope of the best quality, and suitable light — that is, light which is steady and not so bright as to dazzle the eyes nor so dim as to strain them in determining details — microscopic work should improve rather than injure the sight.

If artificial light must be used, give it daylight qualities by placing a piece of ground daylight glass between the source of light and the microscope. This will give one a very soft light like that from a white cloud (§ 92).

§ 162. Position and character of the work-table. —

The work-table should be very firm and large (61×122 cm.

on top, and 73 cm. high; $24 \times 48 \times 29$ in., fig. 57), so that the necessary apparatus and material for work may not be too crowded. The table should also be of the right height to make work by it comfortable. An adjustable stool, something like a piano stool, is convenient; then one may vary the height corresponding to the necessities of special cases. It is a great advantage to sit facing the window if daylight is used; then the hands do not constantly interfere with the il-

lumination. To avoid the discomfort of facing the light a shield (fig. 33) is very useful. For advanced students and private workers a desk like that shown in fig. 58 is very convenient.

TESTING THE MICROSCOPE

§ 163. **Testing the microscope.** — To be of real value this must be accomplished by a person with both theoretical and practical knowledge, and also with an unprejudiced mind. Such a person is not common, and when found does not show overanxiety to pass judgment. Those most ready to offer advice should as a rule be avoided, for in most cases they simply “have an ax to grind,” and are sure to commend only those instruments that conform to the “fad” of the day. From the writer’s experience it seems safe to say that the inexperienced can do no better than to state clearly what he wishes to do with a microscope and then trust to the judgment of one of the optical companies. The makers of microscopes and objectives guard with jealous care the excellence of both the mechanical and optical part of their work, and send out only instruments that have been carefully tested and found to conform to the standard. This would be done as a matter of business prudence on their part, but it is believed by the writer that microscope makers are artists first and take an artist’s pride in their work; they therefore have a stimulus to excellence greater than business prudence alone could give.

What has just been said does not by any means imply that the purchaser of a microscope should blindly accept anything which is offered him. It simply means that if one has no knowledge of a microscope one can hardly pass expert judgment upon it.

§ 164. **Mechanical parts.** — All of the parts should be firm, and not too easily shaken. Bearings should work smoothly. The mirror should remain in any position in which it is placed (fig. 25).

§ 165. **Focusing adjustments.** — The coarse or rapid adjustment should be by rack and pinion and work so smoothly that even the highest power can be easily focused with it by an experienced observer.

This coarse adjustment is liable to work too hard or too easily. If it works too hard, the bearings of the pinion are too tight or the gliding surfaces are sticky and not properly lubricated. If the bearings are

too tight, loosen the screws very slightly; if the bearings are not lubricated or the surfaces are covered with sticky oil, wet a cloth with a good lubricating oil and rub the gliding surfaces well. This will clean them and lubricate them at the same time.

If the tube runs down too easily the bearings of the pinion are too loose and the screws should be tightened a little.

§ 166. **The fine adjustment is more difficult to deal with.**—From the nature of its purpose, unless it is approximately perfect, it would be better off the microscope entirely. It has been much improved recently.

It should work smoothly and be so balanced that one cannot tell by the feeling when using it whether the screw is going up or down. Then there should be absolutely no motion except in the direction of the optic axis; otherwise the image will appear to sway even with central light. Compare the appearance when using the coarse and when using the fine adjustment. There should be no swaying of the image with either if the light is central (§ 116).

§ 167. **Testing the optical parts.**—As stated in the beginning, this can be done satisfactorily only by an expert judge. It would be of very great advantage to the student if he could have the help of such a person. In no case is a microscope to be condemned by an inexperienced person. If the beginner will bear in mind that his failures are due mostly to his own lack of knowledge and lack of skill, and will truly endeavor to learn and apply the principles laid down in this and in the standard works referred to, he will learn after a while to estimate at their true value all the parts of his microscope.

If one can compare a new or unfamiliar microscope with one with which there is entire familiarity, a very good estimate can be made. The first principle is to use some microscope with which one is familiar and to use microscopic preparations of which one knows the structure; then a fair judgment can be made of the excellence of the performance of the new instrument. If there seems to be any defect in the image, make sure

(1) that the lighting is good;

(2) that the proper aperture of the objective is being used and that the condenser is centered (§ 104);

- (3) that the stage is shaded;
- (4) that the tube-length of the microscope is that for which the objectives were corrected (Ch. IX).
- (5) that the preparation is clean and gives a good image with the microscope with which one is familiar. If all the precautions have been taken and still a good image cannot be obtained one should get some more expert friend or the makers to show wherein the trouble lies.

LABORATORY AND HIGH SCHOOL COMPOUND MICROSCOPES

§ 168. **Optical parts.** — A great deal of beginning work with the microscope in biological laboratories is done with simple and inexpensive apparatus. Indeed if one contemplates the large classes in the high schools, the universities, and medical schools, it can readily be understood that microscopes costing from \$25 to \$50 each, and magnifying from 25 to 500 diameters, are all that can be expected. But for the purpose of modern histological investigation and of advanced microscopical work in general, a microscope should have something like the following character: Its optical outfit should comprise dry objectives of 50 mm., 16–18 mm. and 4 mm. equivalent focus. There should be present also a 2 mm. or 1.5 mm. homogeneous immersion objective. Of oculars there should be several of different power.

Even in case all the optical parts cannot be obtained in the beginning, it is wise to secure a stand upon which all may be used when they are finally secured.

§ 169. **Objectives.** — Achromatic objectives will serve all ordinary purposes. For photo-micrography and the finest work where the color values are of essential importance, the apochromatic objectives and compensation oculars should be obtained, if possible, although even in photography and the most difficult fields of microscopy the modern achromatic objectives give excellent results.

§ 170. **Mechanical parts or stand.** — The stand should be low enough so that it can be used in a vertical position on an ordinary table without inconvenience (fig. 25, 38); it should have a jointed (flexible) pillar for inclination at any angle to the horizontal. The adjustments for focusing should be two, — a coarse adjustment or

rapid movement with rack and pinion, and a fine adjustment by means of a micrometer screw. Both adjustments should move the entire tube of the microscope. The body or tube should be short enough for objectives corrected for the short or 160 millimeter tube-length. It is an advantage to have the draw-tube graduated in centimeters and millimeters. The lower end of the draw-tube and of the tube should each possess a standard screw for objectives (fig. 64). The stage should be quite large for the examination of slides with serial sections and other large objects. The substage fittings should be so arranged as to enable one to use the condenser or to dispense entirely with it. The condenser mounting should allow up and down motion (fig. 25).

§ 171. **Quality and cost.** — Laboratory microscopes which will answer nearly all the requirements for work in Biology, including Histology, Embryology, Pathology, and Bacteriology, are listed in the makers' catalogues at about \$65-\$75. The less expensive microscopes are listed at \$25-\$45. Fortunately in the State of New York the State pays half for high school apparatus, so that there is no reason why each high school should not be properly equipped with microscopes of good grade. To avoid misunderstanding it should be added that the quality of the oculars and objectives on the cheaper microscopes is the same as for the best laboratory microscopes. The mechanical work also is of excellent quality.

During the last few years great vigor has been shown in the microscopical world. This has been stimulated largely by the activity in biological and chemico-physical science and the widespread appreciation of the microscope, not only as a desirable, but as a necessary instrument for study and research. The production of the new kinds of glass and the apochromatic objectives has been a no less potent factor in promoting progress.

MARKERS AND MECHANICAL STAGES

Markers are devices to facilitate the finding of some object or part which it is especially desired to refer to again or to demonstrate to a class. The mechanical stage makes it much easier to follow out a series of objects to move the slide when using high powers, and for

complete exploration of a preparation and for blood counting. Most of the mechanical stages have scales and verniers by which an object once recorded may be readily found again.

§ 172. **Marker for preparations** (fig. 59). — This instrument consists of an objective-like attachment which may be screwed into the nose-piece of the microscope. It bears on its lower end a small

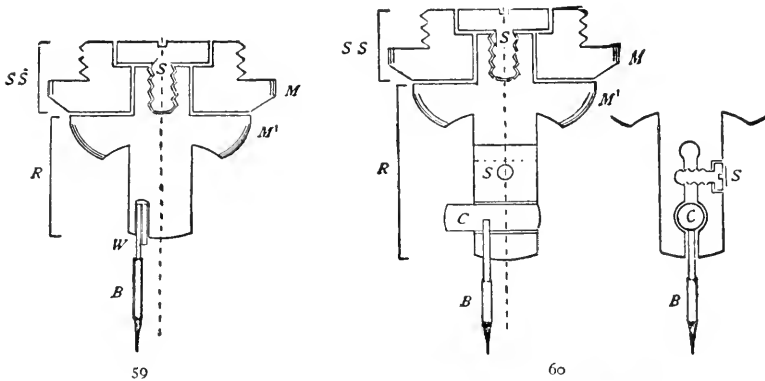

FIG. 59-60. MARKERS FOR MICROSCOPICAL SPECIMENS.

FIG. 59. The simplest form of marker. It consists of the part *SS* with the milled edge (*M*). This part bears the society or objective screw for attaching the marker to the microscope. *R* Rotating part of the marker. This bears the eccentric brush (*B*) at its lower end. The brush is on the wire (*W*). This wire is eccentric, and may be made more or less so by bending the wire. The central dotted line coincides with the axis of the microscope. The revolving part is connected with the "Society Screw" by the small screw (*S*).

FIG. 60. *SS*, *R*, and *B*. All parts same as with fig. 59, except that the brush is carried by a sliding cylinder, the end view being indicated in *B*.

brush and the brush can be made more or less eccentric and can be rotated, thus making a larger or smaller circle. In using the marker the brush is dipped in colored shellac or other cement and when the part of the preparation to be marked is found and put exactly in the middle of the field the objective is turned aside and the marker turned into position. The brush is brought carefully in contact with the cover-glass and rotated. This will make a delicate ring of the colored cement around the object (fig. 61). Within this very small

area the desired object can be easily found on any microscope. The brush of the marker should be cleaned with 95% alcohol after it is used. (Proc. Amer. Micro. Soc., 1894, pp. 112-118).

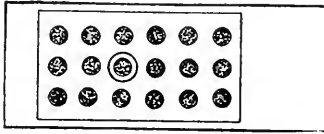

FIG. 61. A MICROSCOPICAL SPECIMEN WITH A SMALL RING ENCLOSING THE PART OF SPECIAL INTEREST.

§ 173. **Pointer in the ocular.** — This is a slender rod of some sort situated at the level of the real image in the microscope, and it appears with the specimen in the field of view. A pointer may be inserted in any ocular as follows: Remove the eye-lens and with a little mucilage or Canada Balsam fasten a hair from a camel's hair or other fine brush to the upper surface of the diaphragm (fig. 23-24) so that it will project about half-way across the opening. If one uses this ocular, the pointer will appear in the field and one can place the specimen so that the pointer indicates it exactly, as in using a pointer on a diagram or on the blackboard. It is not known to the author who devised this method. It is certainly of the greatest advantage in demonstrating objects like amœbas or white blood corpuscles to persons not familiar with them, as the field is liable to have in it many other objects which are more easily seen.

§ 174. **Mechanical stage.** — For high school and ordinary laboratory work a mechanical stage is not needed; but for much work, especially where high objectives are used, a mechanical stage is of great advantage. It is also advantageous if the mechanical stage can easily be removed.

The one found on the most expensive American and English microscopes for the last twenty years and the one now present on the larger

§ 173. **Pointer in the ocular.** — This is a slender rod of some sort situated at the level of the real image in the microscope, and it appears with the specimen in the field of view.

A pointer may be inserted in any ocular as follows:

Remove the eye-lens and with a little mucilage or Canada Balsam

fasten a hair from a camel's hair or other fine brush to the upper surface of the diaphragm (fig. 23-24) so that it will project about half-way across the opening. If one uses this ocular, the pointer will appear in the field and one can place the specimen so that the pointer indicates it exactly, as in using a pointer on a diagram or on the blackboard. It is not known to the author who devised this method. It is certainly of the greatest advantage in demonstrating objects like amœbas or white blood corpuscles to persons not familiar with them, as the field is liable to have in it many other objects which are more easily seen.

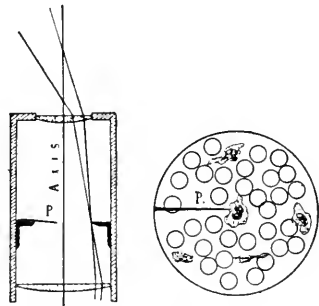

FIG. 62-63. POINTER OCULAR AND MICROSCOPIC FIELD.

PP The pointer attached to the diaphragm of the ocular and extending out into the free space in fig. 62. In fig. 63 the pointer is shown indicating the position of a leucocyte.

continental microscopes is excellent for high powers and preparations of moderate dimensions, but for the study of serial sections and large sections and preparations in general, a form of mechanical stage which gives great lateral, forward, and backward movement, and which is easily removable, is desirable. Such removable mechanical stages are now produced by all the microscope manufacturers. The latest and best forms enable one to explore the serial sections on slides from 25×75 to 50×75 mm.

ROYAL MICROSCOPICAL SOCIETY STANDARDS

§ 175. **Society screw.** — Owing to the lack of uniformity in screws for microscope objectives, the Royal Microscopical Society of London, in 1857, made an earnest effort to introduce a standard size.

In order to facilitate the introduction of this universal screw, or, as it soon came to be called, "The Society Screw," the Royal Microscopical Society undertook to supply standard taps. From the mechanical difficulty in making these taps perfect there soon came to be considerable difference in the "Society Screws," and the object of the society in providing a universal screw was partly defeated. (See Edward Bausch, *Trans. Amer. Micr. Soc.*, 1884, p. 153.)

In 1884 the American Microscopical Society appointed Mr. Edward Bausch and Prof. William A. Rogers upon a committee to correspond with the Royal Microscopical Society, with a view to perfecting the standard "Society Screw," or of adopting another standard and of perfecting methods by which the screws of all makers might be truly uniform. Although this matter was earnestly considered at the time by the Royal Microscopical Society, the mechanical difficulties were so great that the improvements were abandoned.

Fortunately, however, during the year 1896 that society again took hold of the matter in earnest and the "Society Screw" is now accurate, and facilities for obtaining the standard are so good that there

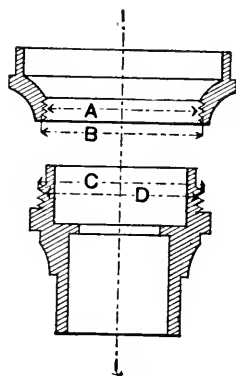

FIG. 64. ROYAL MICROSCOPICAL SOCIETY'S STANDARD SCREW FOR OBJECTIVES.

(From the *Jour. Roy. Micr. Soc.*, Aug. 1896).

is a reasonable certainty that the universal screw for microscopic objectives may be realized. It is astonishing to see how widely the "Society Screw" has been adopted. Indeed there is not a maker of first-class microscopes in the world who does not supply the objectives and stands with the "Society Screw," and an objective in England or America which does not have this screw should be looked upon with suspicion. That is, it is either old, cheap, or not the product of one of the great opticians. For the Standard, or "Society Screw," see: *Trans. Roy. Micr. Soc.*, 1857, pp. 39-41; 1859, pp. 92-97; 1860, pp. 103-104. (All to be found in *Quar. Jour. Micr. Sci.*, o. s., vols. VI, VII, VIII). *Proc. Amer. Micr. Soc.*, 1884, p. 274; 1886, p. 199; 1893, p. 38. *Journal of the Royal Microscopical Society*, August, 1896.

In this last paper of four pages the matter is very carefully gone over and full specifications of the new screw given. It conforms almost exactly with the original standard adopted by the society, but means have been devised by which it may be kept standard.

The following discussion and specifications are from the *Journal of the Royal Microscopical Society*, 1915, pp. 230-231.

"OBJECTIVE SCREW THREAD

"The question of standardization of the Objective Screw Thread was first discussed by the Microscopical Society in 1857, and the first sizing tools were issued in 1858.

"In 1896 the Council of the Royal Microscopical Society issued another Report, and drew up a specification defining the limits of variation allowable from the original standard screw thread.

"Difficulties having arisen in connexion with the testing and adjusting of the sizing tools supplied by the Society, the Council in 1911 appointed a Gauges Committee to look into the question of obtaining and testing further tools, and they now have pleasure in informing Fellows of the Society that an arrangement has been made with the Director of the National Physical Laboratory whereby the standard gauges of the Society have been deposited at the National Physical Laboratory. The Council has also arranged for the issue of new

objective screw sizing taps and dies, which have been tested and passed by the N.P.L. and are within the following limits:

“ *Tap* for sizing Nose-pieces: full diameter between 0.800 in. (= 20.3198 mm.) and 0.803 in. (= 20.3960 mm.).

“ *Die* for sizing Objective: core diameter of thread between 0.7596 in. (= 19.2937 mm.) and 0.7626 in. (= 19.3699 mm.).

“ A certificate of accuracy is issued with each tap and die. These sizing tools are now on sale, and may be obtained by application to the Secretaries of the Royal Microscopical Society.

“ The standard specification for the objective thread has not been altered, and is as follows:

“SPECIFICATION OF THE ROYAL MICROSCOPICAL SOCIETY
STANDARD SCREW THREAD FOR OBJECTIVES

“ *Metrical Measurements in Brackets*

“ *Diameter.* — 0.800 in. [20.3198 mm.].

“ *Pitch.* — 36 to the inch [14.17 to the cm.].

“ *Form.* — Whitworth screw, i.e. a V-shaped thread, sides of thread inclined at an angle of 55° to each other, one-sixth of the V depth being rounded off at the top and the bottom of the thread (fig. 64).

“ *Length of Thread on Objective,* 0.125 in. (= 3.1750 mm.).

“ *Plain Fitting above Thread of Objective,* 0.1 in. (= 2.5400 mm.) long, not to exceed 0.759 in. (= 19.2784 mm.) in diameter.

“ *Length of Screw of Nose-piece* to be not less than 0.125 in. (= 3.1750 mm.).

“ *Limits*

“ *Nose-piece:*

“ *Core Diameter of Thread (A)* not to exceed 0.7674 in. (= 19.4918 mm.), or be less than 0.7644 in. (= 19.4156 mm.).

“ *Full Diameter of Thread (B)* not to exceed 0.803 in. (= 20.3960 mm.), or be less than 0.800 in. (= 20.3198 mm.).

“ *Objective: —*

“ *Full Diameter of Thread (C)* at top of thread not to exceed 0.7982 in. (= 20.2741 mm.), or to be less than 0.7952 in. (20.1979 mm.).

“*Core Diameter of Thread (D)* at bottom of thread not to exceed 0.7626 in. (= 19.3699 mm.), or to be less than 0.7596 in. (= 19.2937 mm.).”

§ 176. **Royal Microscopical Society standards for eye-pieces and substage.** — The standards adopted in 1899 were four in number, but in actual practice only two are used:

Small or Continental size, 0.917 in. = 23.300 mm.

Large size, 1.27 in. = 32.258 mm.

The size here given is the internal diameter of the draw-tube; the tightness of the fit being left to the manufacturer.

Standard size for substage fitting, 1.527 in. = 38.786 mm.

The gauges for the above sizes have been deposited at the National Physical Laboratory, and maker's gauges may be compared with the standards on payment of a small fee.

For Collateral Reading, see the list at the end of Chs. I and II.

CHAPTER IV

INTERPRETATION OF APPEARANCES

§ 186. Apparatus and material for Chapter IV.

1. Laboratory compound microscope (fig. 25).
2. Preparation of fly's wing (§ 188).
3. 50% glycerin (§ 202).
4. Slides and covers (Ch. X).
5. Preparation of letters in stairs (fig. 66).
6. Gum arabic mucilage for air bubbles (§ 104).
7. Oil or milk for oil globules (§ 197).
8. Solid glass rod and glass tube (§ 202).
9. Collodion (§ 204).
10. Carmine, starch, chalk dust (§ 206).
11. Frog (§ 209).
12. Castor oil (§ 209).
13. Micro-polariscope (Ch. VIII).
14. Fine forceps (fig. 70).
15. Eosin (§ 202).

§ 187. Appearances which seem perfectly unmistakable with a low power may be found erroneous or very inadequate with high powers; for details of structure which cannot be seen with a low power may become perfectly evident with a higher power or a more perfect objective. On the other hand, the problems of microscopic structure become more and more complex with increased precision of investigation and more perfect optical appliances, for structures that appeared intelligible with a less perfect microscope may show complexities in their details of structure with the more perfect microscope which open up an entirely new field for interpretation.

One must always be on the lookout for errors in judgment induced by color effects due to purely optical means and to color in the specimen and also to avoid confusing refraction, reflection, and diffraction effects with pigments, or actual structures of any kind. It is not infrequent in searching for malarial pigment in the red blood corpuscles to mistake the dark-looking crenations on the corpuscles for the pigment sought (§ 187a).

The need of the most careful observation and constant watchfulness lest the appearances may be deceptive is thus admirably stated

by Dallinger (see Carpenter-Dallinger, p. 427): "The correctness of the conclusions which the microscopist will draw regarding the nature of any object from the visual appearances which it presents to him when examined in the various modes now specified will necessarily depend in a great degree upon his previous experience in microscopic observation and upon his knowledge of the class of bodies to which the particular specimen may belong. Not only are observations of *any* kind liable to certain fallacies arising out of the previous notions which the observer may entertain in regard to the constitution of the objects or the nature of the actions to which his attention is directed, but even the most practised observer is apt to take no note of such phenomena as his mind is not prepared to appreciate. Errors and imperfections of this kind can only be corrected, it is obvious, by general advance in scientific knowledge; but the history of them affords a useful warning against hasty conclusions drawn from a too cursory examination. If the history of almost any scientific investigation were fully made known, it would generally appear that the stability and completeness of the conclusions finally arrived at had been only attained after many modifications, or even entire alterations, of doctrine. And it is therefore of such great importance as to be almost essential to the correctness of our conclusions that they should not be finally formed and announced until they have been tested in every conceivable mode. It is due to science that it should be burdened with as few false facts [artifacts] and false doctrines as possible. It is due to other truth-seekers that they should not be misled, to the great waste of their time and pains, by our errors. And it is due to ourselves that we should not commit our reputation to the chance of impairment by the premature formation and publication of conclusions which may be at once reversed by other observers better informed than ourselves, or may be proved fallacious at some future time, perhaps even by our own more extended and careful researches. *The suspension of the judgment whenever there seems room for doubt* is a lesson inculcated by all those philosophers who have gained the highest repute for practical wisdom; and it is one which the microscopist cannot too soon learn or too constantly practise."

The general law for the whole matter is to study the object in every way possible (§ 218).

For the experiments, § 188-201, no condenser is to be used, except in a part of § 201.

§ 187a. "The distinction between a dark element which is referable to pigment and a dark element which is referable to the deflection of light can generally be made by watching the effect produced by the alteration of the focus. Where the dark element corresponds to a point from which light is deflected a change of the focus will be associated with a change from dark to bright. Where pigment is in question a change of focus will substitute only a more diffuse for a less diffuse dark element." (Wright, p. 44.)

§ 188. **Dust or Cloudiness on the Ocular.** — Employ the 16 mm. objective, 4x or 5x ocular, and fly's wing as object.

Unscrew the field-lens and put some particles of lint from dark cloth on its upper surface. Replace the field-lens and put the ocular in position (§ 45). Light the field well and focus sharply. The image will be clear, but part of the field will be obscured by the irregular outline of the particles of lint. Move the object to make sure this appearance is not due to it.

Grasp the ocular by the milled ring, just above the tube of the microscope and rotate it. The irregular objects will rotate with the ocular. Cloudiness or particles of dust on any part of the ocular may be detected in this way.

Unscrew the field-lens and remove the lint before proceeding.

§ 189. **A small bright field.** — With low objectives (25-50 mm.), if too small a diaphragm is used and put close to the object, only the central part of the field will be illuminated, and around the small light circle will be seen a dark ring (fig. 65). If the diaphragm is lowered or a sufficiently large one employed, the entire field will be lighted (see also § 90 for diaphragms with the condenser).

§ 190. **Relative position of objects or parts of the same object.** — The general rule is that objects highest up come into focus last in focusing up, first in focusing down.

§ 191. **Objects having plane or irregular outlines.** — As object use three printed letters in stairs mounted in Canada balsam (fig. 66). The first letter is placed directly upon the slide, and covered with a small piece of glass about as thick as a slide. The second letter is

placed upon this and covered in like manner. The third letter is placed upon the second thick cover and covered with an ordinary

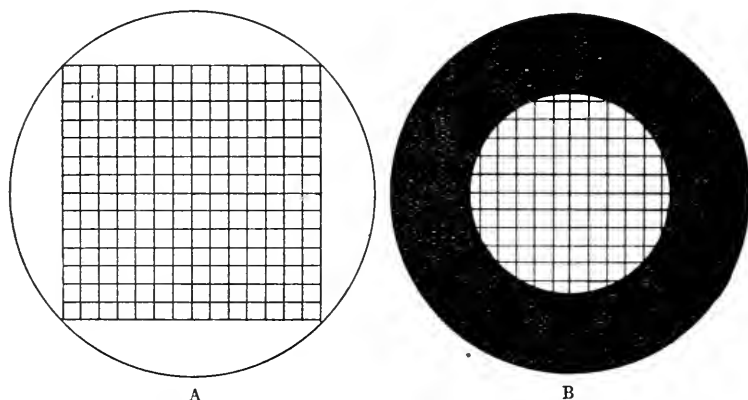

FIG. 65. THE MICROSCOPIC FIELD COMPLETELY AND ONLY PARTLY ILLUMINATED.

A The field completely illuminated; a net micrometer is used as object.

B The field is only partly illuminated; the same net micrometer is used as object, but not all of it appears in the partially lighted field.

cover-glass. The letters should be as near together as possible, but not overlapping. Employ the same ocular and objective as above (§ 188).

Lower the tube till the objective almost touches the top letter; then look into the microscope and slowly focus up. The lowest letter

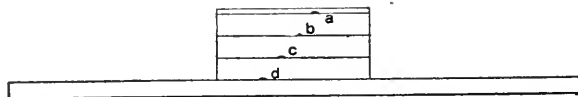

FIG. 66. LETTERS IN STAIRS TO DETERMINE RELATIVE POSITION BY FOCUSING UP AND DOWN.

will first appear and then, as it disappears, the middle one will appear and so on. Focus down, and the top letter will first appear, then the middle one, etc. The relative position of objects is determined exactly in this way in practical work.

For example, if one has a micrometer ruled on a cover-glass 0.15-0.25 mm. thick, it is not easy to determine with the naked eye which is the ruled surface. But if one puts the micrometer under a microscope and uses a 4 mm. objective, it is easily determined. The cover should be laid on a slide and focused till the lines are sharp. Now, without changing the focus in the least, turn the cover over. If it is necessary to focus up to get the lines of the micrometer sharp, the lines are on the upper side. If one must focus down, the lines are on the under surface. With a thin cover and delicate lines this method of determining the position of the rulings is of considerable practical importance.

§ 192. **Determination of the form of objects.** — The procedure is exactly as for the determination of the form of large objects. That is, one must examine the various aspects. For example, if one were placed in front of a wall of some kind, one could not tell whether it was a simple wall or whether it was one side of a building unless in some way one could see more than the face of the wall. In other words, in order to get a correct notion of any body, one must examine more than one dimension, — two for plane surfaces, three for solids. So for microscopic objects, one must in some way examine more than one face. To do this with small bodies in a liquid the bodies may be made to roll over by pressing on one edge of the cover-glass. And in rolling over the various aspects are presented to the observer. With solid bodies, like the various organs, correct notions of the form of the elements can be determined by studying sections cut at right angles to each other. The methods of getting the elements to roll over, and of sectioning in different planes, are in constant use in Histology, and the microscopist who neglects to see all sides of the tissue elements has a very inadequate and often a very erroneous conception of their true form.

§ 193. **Transparent objects having curved outlines.** — The success of these experiments will depend entirely upon the care and skill used in preparing the objects, in lighting, and in focusing.

Employ a 4 mm. or higher objective and an 8x or 10x ocular for all the experiments. It may be necessary to shade the object (§ 140) to get satisfactory results. When a diaphragm is used the opening should be small and it should be close to the object.

§ 194. **Air bubbles.** — Prepare these by placing a drop of thin gum arabic mucilage on the center of a slide and beating it with a scalpel blade until the mucilage looks milky from the inclusion of air bubbles. Put on a cover-glass but do not press it down.

§ 195. **Air bubbles with central illumination.** — Shade the object and with the plane mirror light the field with central light (fig. 21 B).

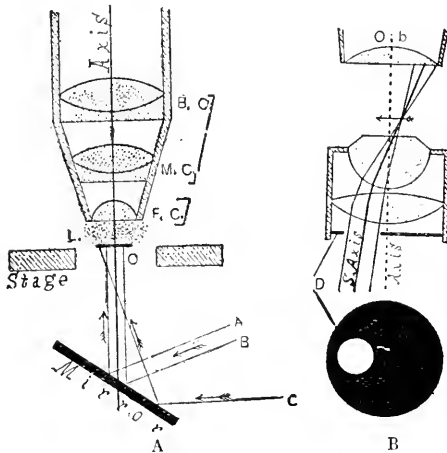

FIG. 67. OBLIQUE ILLUMINATION WITH A MIRROR AND WITH A CONDENSER.

A The light is shown to be oblique with ray *c*; rays *A B* are central. The arrows indicate the path of the rays. (For the objective see explanation of fig. 35.)

B Abbe condenser with an eccentric diaphragm (*D*) admitting light only on one side.

Axis The principal optic axis. *Ob* Objective.
S. *Axis* Secondary axis.

Search the preparation until an air bubble is found appearing about 1 mm. in diameter, get it into the center of the field, and if the light is central the air bubble will appear with a wide, dark, circular margin and a small bright center. If the bright spot is not in the center, adjust the mirror until it is.

This is one of the simplest and surest methods of telling when the light is central or axial when no condenser is used (§ 98).

Focus both up and down, noting that, in focusing up, the central spot becomes very clear and the black ring very sharp. On elevating the tube of the microscope still more the center becomes dim, and the whole bubble loses its sharpness of outline.

§ 196. **Air bubbles with oblique illumination.** — Remove the substage of the microscope and all the diaphragms. Swing the mirror so that the rays may be sent very obliquely upon the object (fig. 67). The bright spot will appear no longer in the center, but on the side away from the mirror (fig. 68 A).

§ 197. **Oil globules.** — Prepare these by beating a small drop of clove or other oil with gum arabic mucilage on a slide and covering as directed for air bubbles (§ 194), or use a drop of milk in a drop of water.

§ 198. **Oil globules with central illumination.** — Use the same diaphragm and light as above (§ 195). Find an oil globule appearing about 1 mm. in diameter. If the light is central a bright spot will appear in the center. Focus up and down and note that the dark ring is narrower than with air and that the bright center of the oil globule is clearest last in focusing up.

§ 199. **Oil globules with oblique illumination.** — Remove the substage, etc., as above, swing the mirror to one side and light, with oblique light. The bright spot will be eccentric, and will appear to be on the same side as the mirror (fig. 68).

§ 200. **Oil and air together.** — Make a preparation exactly as described for air bubbles (§ 194), and add at one edge a little of the mixture of oil and mucilage (§ 197); cover and examine.

The substage need not be used in this experiment. Search the preparation until an air bubble and an oil globule, each appearing about 1 mm. in diameter, are found in the same field of view. Light first with central light, and note that, in focusing up, the air bubble comes into focus first and that the central spot is smaller than that of the oil globule. Then, of course, the black ring will be wider in the air bubble than in the oil globule. Make the light oblique. The bright spot in the air bubble will move away from the mirror, while that in the oil globule will move toward it (fig. 68).

As the air bubble is of less refractive index than the mucilage it will act like a concave lens (fig. 69), while the oil globule, having a greater refractive index than the mucilage, will act as a convex lens (fig. 69, § 200a).

It is possible to distinguish oil and air optically, as described above, only when quite high powers are used and very small bubbles are

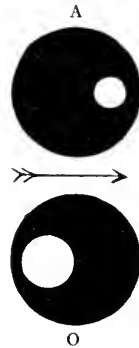

FIG. 68. SMALL AIR BUBBLE (A) AND OIL GLOBULE (O) WITH OBLIQUE LIGHT.

The arrow indicates the direction of the light.

selected for observation. If a 16 mm. objective is used instead of a 4 mm., the appearances will vary considerably from that given above for the higher power. It is well to use a low as well as a high power. Marked differences will also be seen in the appearances with objectives of small and of large aperture, as the larger aperture takes in more oblique rays and hence the black margin is narrowed (§ 202).

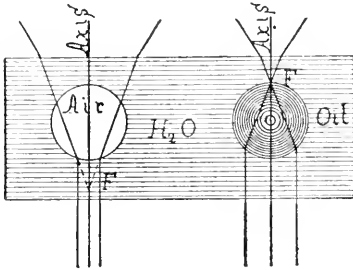

FIG. 69. AIR BUBBLE AND OIL GLOBULE IN WATER.

Axis The principal optic axis.

F, F The principal foci of the air and oil. As the air is less refractive than water its focus is virtual. The focus of the oil globule is real, as its refraction is greater than water.

will be lighted, and the bright central spot will be somewhat dark. Use also the condenser and dark-ground illumination (§ 123).

Experiments in which the substage condenser is used (§ 202-209).

§ 202. **Distinctness of outline.** — In refraction images this depends on the difference between the refractive power of a body and that of the medium which surrounds it. The oil and air were very distinct in outline, as both differ greatly in refractive power from the medium which surrounds them, the oil being more refractive than the mucilage and the air less (fig. 69).

Place a fragment of a cover-glass on a clean slide, and cover it (fig. 70). Use it as object and employ the 16 mm. objective and 8x or 10x ocular. The fragment will be outlined by a dark band. Put a drop of water at the edge of the cover-glass. It will run in and immerse the fragment. The outline will remain distinct, but the dark band will be somewhat narrower. Remove the cover-glass, wipe it

§ 200a. It should be remembered that the image in the compound microscope is inverted (fig. 20); hence the bright spot really moves toward the mirror for air, and away from it for oil.

§ 201. **Air and oil by reflected light.** — Use the same preparation as in § 200. Cover the diaphragm or mirror so that no transmitted light can reach the preparation. The oil and air will appear like globules of silver on a dark ground. The part that was darkest in each with transmitted light

dry, and wipe the fragment and slide dry also. Put a drop of 50% glycerin on the middle of the slide and mount the fragment of cover-glass in that. The dark contour will be much narrower than before.

Draw a solid glass rod out to a fine thread. Mount one piece in air, and the other in 50% glycerin. Put a cover-glass on each. Employ the same optical arrangement as before. Examine the one in air first. There will be seen a narrow, bright band, with a wide, dark band on each side (fig. 71a).

The one in glycerin will show a much wider bright central band, with the dark borders correspondingly narrow (fig. 71b). The dark contour depends also on the numerical aperture of the objective — being wider with low apertures. This can be readily understood when it is remembered that the greater the aperture the more oblique the rays of light that can be received, and the dark band simply represents an area in which the rays are so greatly bent or refracted (fig. 69) that they cannot enter the objective and contribute to the formation of the image; the edges are dark simply because no light from them reaches the observer.



FIG. 71. GLASS RODS IN AIR AND IN GLYCERIN.

a Glass rod in air and viewed by central transmitted light.

b Glass rod mounted in 50% glycerin; the dark border is narrower than when mounted in air.

is made of practical use in the determination of the refractive index of crystals. When the crystal and liquid are of the same index there will be no band, and the more they differ, the wider will be the band. As shown in § 194-201, lighting with oblique light, also focusing up and down, will indicate whether the crystal is of greater or less index



FIG. 70. FINE FORCEPS FOR PLACING COVER-GLASSES ON SPECIMENS.

If the glass rod or any other object were mounted in a medium of the same color and refractive power, it could not be distinguished from the medium.

The effect of the immersing liquid on the contour bands around any transparent object

than the liquid. For this method a series of liquids of known index of refraction must be at hand. For a complete discussion, see Chamot, Ch. IX.

A very striking and satisfactory demonstration may be made by painting a zone or band of eosin or other transparent color on a solid glass rod, and immersing the rod in a test tube or vial of cedar oil,

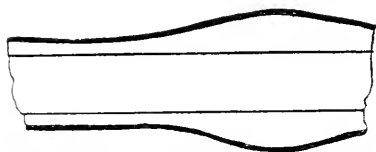

FIG. 72. SOLID GLASS ROD COATED WITH COLLODION TO SHOW DOUBLE CONTOUR.

clove oil, or turpentine. Above the liquid the glass rod is very evident, but under the liquid it can hardly be seen except where the red band is painted on it. This is a good example of a color image and of a refraction image to the naked eye (§ 137).

§ 202a. Some of the rods have air bubbles in them, and then there results a capillary tube when they are drawn out. It is well to draw out a glass tube into a fine thread and examine it as described. The central cavity makes the experiment much more complex.

§ 203. **Highly refractive.** — This expression is often used in describing microscopic objects (medullated nerve fibers, for example), and means that the object will appear to be bordered by a wide, dark margin when it is viewed by transmitted light. And from the above (§ 202), it would be known that the refractive power of the object and the medium in which it was mounted must differ considerably.

§ 204. **Doubly contoured.** — This means that the object is bounded by two usually parallel dark lines with a lighter band between them. In other words, the object is bordered by (1) a dark line, (2) a light band, and (3) a second dark line.

This may be demonstrated by coating a fine glass rod (§ 202) with one or more coats of collodion or celloidin and allowing it to dry, and then mounting in 50% glycerin as above (§ 202). Employ a 4 mm. or higher objective, light with transmitted light, and it will be seen that where the glycerin touches the collodion coating there is a dark line, next this is a light band, and finally there is a second dark line where the collodion is in contact with the glass rod (fig. 72).

§ 204a. The collodion used is a 6% solution of soluble cotton in equal parts of sulphuric ether and 95%, or, preferably, absolute alcohol. It is well to dip the rod two or three times in the collodion and to hold it vertically while drying. The collodion will gather in drops, and one will see the difference between a thick and a thin membranous covering (fig. 72).

§ 205. **Optical section.** — This is the appearance obtained in examining transparent or nearly transparent objects with a microscope when some plane below the upper surface of the object is in focus. The upper part of the object which is out of focus obscures the image but slightly. By changing the position of the objective or object, a different plane will be in focus and a different optical section obtained. The most satisfactory optical sections are obtained with high objectives having large aperture.

Nearly all the transparent objects studied may be viewed in optical section. A striking example will be found in studying Mammalian red blood corpuscles on edge. The experiments with the solid glass rods (fig. 71) furnish excellent and striking examples of optical sections.

§ 206. **Currents in liquids.** — Employ a 16 mm. objective, and as object put a few particles of carmine, starch, or chalk dust on the middle of a slide and add a drop of water. Grind the carmine or other substance well with a scalpel blade; leave the preparation uncovered. If the microscope is inclined, a current will be produced in the water, and the particles will be carried along by it. Note that the particles seem to flow up instead of down; why is this? How would it appear to flow with an erecting microscope (§ 146, 149a)?

§ 207. **Velocity under the microscope.** — In studying currents or the movement of living things under the microscope, one should not forget that the apparent velocity is as unlike the real velocity as the apparent size is unlike the real size. If one consults fig. 29 it will be seen that the actual size of the field of the microscope with the different objectives and oculars is inversely as the magnification. That is, with great magnification only a small area can be seen. The field appears to be large, however, and if any object moves across the field it may appear to move with great rapidity, whereas if one measures the actual distance passed and notes the time, it will be seen that the actual motion is quite slow. One should keep this in mind in studying

the circulation of the blood. The truth of what has just been said can be easily demonstrated in studying the circulation in the gills of *Necturus*, or in the frog's foot, by using first a low power in which the field is actually of considerable diameter (fig. 29; Table, § 49) and then using a high power. With the high power the apparent motion will appear much more rapid. For spiral, serpentine, and other forms of motion, see Carpenter-Dallinger, p. 433.

§ 208. **Pedesis or Brownian movement.** — Employ the same object as above, but a 4 mm. or higher objective in place of the 16 mm. Make the body of the microscope vertical so that there may be no currents produced. Use a small diaphragm and light the field well. Focus and there will be seen in the field large motionless masses, and between them small masses in constant motion. This is an indefinite, dancing, or oscillating motion.

This indefinite but continuous motion of small particles in a liquid is called Brownian movement or Pedesis; also, but improperly, molecular movement, from the smallness of the particles.

The motion is increased by adding a little gum arabic solution or a slight amount of silicate of soda or soap; sulphuric acid and various saline compounds retard or check the motion. One of the best objects is lamp-black ground up in water with a little gum arabic. Carmine prepared in the same way, or simply in water, is excellent; and very finely powdered pumice-stone in water has for many years been a favorite object. Pedesis is exhibited by all solid matter if it is finely enough divided.

Compare the pedetic motion with that of a current by slightly inclining the tube of the microscope. The small particles will continue their independent leaping movements while they are carried along by the current. The pedetic motion makes it difficult to obtain good photographs of milk globules and other small particles. The difficulty may be overcome by mixing the milk with a very weak solution of gelatin and allowing it to cool (10% gelatin is good).

Until recently no adequate explanation of this movement had been offered. At the present time it is believed to be due to the kinetic activity of matter, and in itself to be one of the best proofs of that activity. This is what is said by Rutherford: "The character of the

Brownian movement irresistibly impresses the observer with the idea that the particles are hurled hither and thither by the action of forces resident in the solution, and that these can only arise from the continuous and ceaseless movement of the invisible molecules of which the fluid is composed." "Whatever may be the exact explanation of this phenomenon, there can be but little doubt that it results from the movements of the molecules of the solution, and is thus a striking, if somewhat indirect, proof of the general correctness of the kinetic theory of matter." *Nature*, Vol. 81, 1909, pp. 257-263; *Science*, N. S., Vol. 30, 1909, pp. 289-303.

By the aid of the ultra-microscope it has been shown that the particles in smoke, etc., exhibit the pedetic movement even more strikingly than do those in liquids.

§ 209. **Demonstration of pedesis with the polarizing microscope (Ch. VIII).**— The following demonstration shows conclusively that the pedetic motion is real and not illusive (Ranvier, p. 173).

Open the abdomen of a dead frog (an alcoholic or formalin specimen is satisfactory). Turn the viscera to one side and observe the small whitish masses at the emergence of the spinal nerves. With fine forceps remove one of these and place it on the middle of a clean slide. Add a drop of water, or of water containing a little gum arabic. Rub the white mass around in the drop of liquid and soon the liquid will have a milky appearance. Remove the white mass, place a cover-glass on the milky liquid, and seal the cover by painting a ring of castor oil all around it, half the ring being on the slide and half on the cover-glass. This is to avoid the production of currents by evaporation.

Put the preparation under the microscope and examine with first a low power, then a high power (4 mm.). In the field will be seen multitudes of crystals of carbonate of lime; the larger crystals are motionless, but the smallest ones exhibit marked pedetic movement.

Use the micro-polariscope (Ch. VIII), light with great care, and exclude all adventitious light from the microscope by shading the object (§ 140) and also by shading the eye. Focus sharply and observe the pedetic motion of the small particles, then cross the polarizer and analyzer, that is, turn one or the other till the field is dark. Part

of the large motionless crystals will shine continuously and a part will remain dark, but small crystals between the large ones will shine for an instant, then disappear, only to appear again the next instant. This demonstration is believed to furnish absolute proof that the pedetic movement is real and not illusory.

For the help given by the micro-spectroscope see Ch. VIII.

§ 210. Use of dark-ground illumination for interpreting appearances.

— Dark-ground illumination is almost invaluable for bringing out details of structure and for showing movement in living things. The granules and different parts in living cells and minute organisms are so nearly the same refractive index that it is exceedingly difficult to differentiate them with the ordinary methods of illumination. On the other hand, with dark-ground illumination the different structures stand out with the greatest clearness.

§ 211. Specimens to use for dark-ground illumination. —

(1) Organisms from hay infusion. Use for the infusion a small fruit jar or other glass dish. Go to a stream or pond and from a shallow stagnant pool along the edge take some of the surface of the mud and put it into the jar with some of the water. Add some of the dead grass found along the edge of the pond, cut up into short pieces. Set in a warm dimly lighted or dark place for a day or longer. This should soon be alive with all sorts of minute living things.

If it is not easy to get the water, mud, and dead grass, fairly good results are obtained by putting some ordinary hay in water of any kind.

With fine forceps take a leaf or piece of stem of the dead grass and put it on a slide 1 mm. thick. Move it around and press it down so that a good drop of liquid and debris will be on the slide. Remove the grass and cover the liquid with a 0.15 mm. cover-glass. This should be studied fresh with a 4 mm. objective, 5x or 10x ocular, and transmitted light. Now put in place the dark-ground illuminator, center it (§ 126), and add some distilled water or some homogeneous liquid to the top of the condenser and run it up till the liquid is in contact with the under side of the slide.

Put a drop of homogeneous liquid on the cover-glass and use a homogeneous immersion objective in which the aperture has been cut down to 0.95 or less. Examine as directed in § 127-128.

(2) Saliva. Put a drop of saliva on a slide 1 mm. thick and cover it with a 0.15 mm. cover-glass. Examine as in (1).

Note the pedetic or Brownian movement of the granules in the rounded salivary corpuscles, the minute granules in the broad oval epithelium, etc.

(3) Fresh blood. Make a preparation of fresh human blood as follows: Use a clean slide 1 mm. thick and have ready and handy a cover-glass 0.15 mm. thick. Wash the middle finger well with soap and water and wipe it dry with a piece of gauze. Then wipe it again with a piece of gauze wet with 95% alcohol.

Sterilize a needle by heating it to redness. Make two or three good pricks in the clean finger with the sterile needle. Squeeze the finger well and a drop of blood will run out. Touch this blood to the middle of the slide and cover it immediately. Press the cover down so that there will be a very thin layer of blood. Examine with the dark-ground illumination, using the homogeneous objective with reduced aperture. Use homogeneous liquid to join the slide and top of the condenser.

The appearance of a fresh blood preparation with dark-ground illumination will be a revelation to one who has studied blood only with the usual transmitted light. The white corpuscles, or leucocytes are very striking objects, especially the polymorphonuclear ones with granules. These granules show the pedetic or Brownian movement well; and if the room is warm where the work is done the amœboid movement is very striking. For the blood of 2 individuals studied the leucocytes in one (male) moved 6.8μ per minute; in the other (female) the movement was 18μ per minute.

In addition to the corpuscles and minute granules of various kinds one is almost sure to see the fibrin filaments arranged something like a spider's web.

§ 212. **Difference of appearance due to difference of focus.** — If one takes a geometrical pattern like that shown in fig. 73 and looks at it in the ordinary way the appearance is that of white spots on a dark field. If now the head is held closer and closer to the picture an inversion will take place and the appearance is of dark spots in a white field. This illustrates how difficult it is to determine the real appear-

ance under the microscope of objects having geometrical patterns and especially if there are several of them superimposed, as with the wire gauze experiment (§ 216). The image is often just as satisfactory in one focus as in another, although the appearance changes very markedly in the two positions.

§ 213. **Comparing two microscopic fields side by side.** — It is so difficult to carry in the mind the exact appearance of any structure or complex pattern, that many efforts have been made to have the microscopic images side by side so that they can be looked at at the same time. This has been accomplished by using two microscopes and projecting two fields side by side, as can be done by having two microscopes like the one shown in fig. 113.

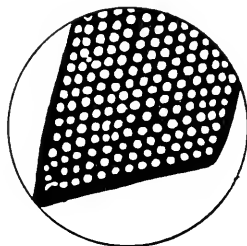

FIG. 73. GEOMETRICAL PATTERN TO SHOW DIFFERENCE OF APPEARANCE DEPENDING ON THE FOCUS. (From Sir A. R. Wright's *Microscopy*).

Another method is by means of a comparison ocular (fig. 74). Then two objects under two microscopes have the images side by side in the ocular, half the field being taken up by one object and half by the other; then the eye can compare two structures side by side.

§ 214. **Musæ volitantes.** — These specks or filaments in the eyes due to minute shreds or opacities of the vitreous humor sometimes appear as part of the object as they are projected into the field of vision. They may be seen by looking into the well-lighted microscope when there is no object under the microscope. They may also be seen by looking at brightly illuminated snow or other white surface. By studying them carefully it will be seen that they are somewhat movable and float across the field of vision, and thus do not remain in one position as do the objects under observation. Furthermore, one may, by taking a little pains, familiarize himself with the special forms in his own eyes so that the more conspicuous at least may be instantly recognized.

§ 215. **Miscellaneous observations.** — In addition to the above experiments it is very strongly recommended that the student follow

the advice of Beale, p. 248, and examine first with a low power then with a higher power; mounted dry, then in water; lighted with re-

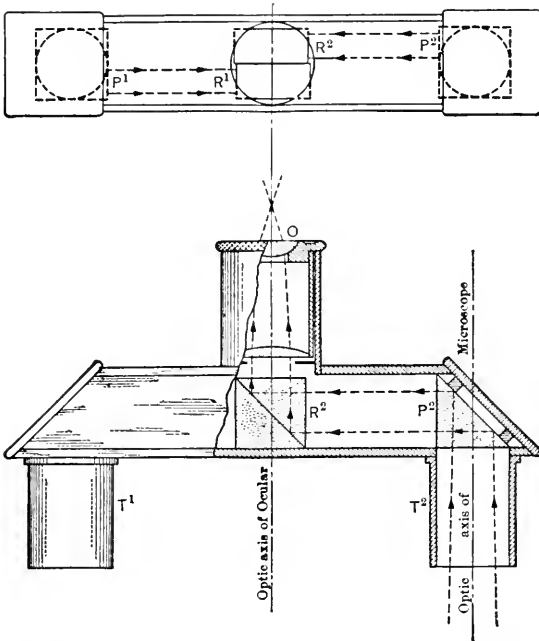

FIG. 74. COMPARISON OCULAR FOR PLACING HALF THE FIELDS OF TWO MICROSCOPES SIDE BY SIDE. ($R^1 R^2$).

(Bausch & Lomb Optical Co., from Chamot).

T^1 To fit into the tube of the left microscope.

T^2 To fit into the tube of the right microscope.

P^2 Prism to reflect the beam from the right microscope to the prism R^2 , whence it is reflected up through the ocular (O) into the right half of the field shown above in the face view.

$P^1 R^1$ The prism and left half of the field shown in face view in the diagram at the top.

flected light, then with transmitted light, the following: potato, wheat, rice, and corn starch (easily obtained by scraping the potato and the grains mentioned); bread crumbs; portions of feather (portions of feather accidentally present in histological preparations have been

mistaken for lymphatic vessels — Beale, 288); fibers of cotton, linen, and silk (textile fibers accidentally present have been considered nerve fibers, etc.); the scales of butterflies and moths, especially the common clothes moths; the dust swept from carpeted and wood floors; tea leaves and coffee grounds; dust found in living rooms and places not frequently dusted (in the last will be found a regular museum of objects).

§ 216. **Wire gauze experiment.** — For a very striking illustration of the need of care in interpretation with naked eye observation, take two pieces of wire gauze such as is used for milk strainers or some slightly coarser. Place these over each other and look through them toward the light. Where there is but a single layer the weave is evident, but where the two pieces overlap the appearance is very puzzling, and changes constantly as one piece is rotated, bringing the threads and meshes at an angle. One could hardly believe that the structure is so simple when looking through two layers of the gauze.

If it is necessary then to see all sides of an ordinary gross object, to observe it in various positions and with varying illumination and under various conditions of temperature, moisture, and in single as well as multiple layers to obtain a fairly accurate and satisfactory knowledge of it, so much the more is it necessary to be satisfied with the interpretation of appearances under the microscope only after applying every means of investigation at command. Even then only such details of the image will be noted and understood as the brain behind the eye has been trained to appreciate.

§ 216a. **Experiment with wire gauze.** — For this very striking, naked-eye experiment with the wire gauze the author is indebted to a suggestion from Dr. Chamot.

§ 217. **Inversion of the microscopic image.** — As all the images produced by the modern compound microscope are inverted unless they are erected by a special arrangement of prisms, one must learn to interpret the appearances in an inverted image with the same certainty as in erect images seen by the naked eye or through the simple microscope. It may be remarked in passing that with the compound microscope the image is actually erect on the retina of the eye (fig. 3, 20).

With the compound microscope it soon becomes as easy to move the slide in the right direction to see a desired part as it is to make the proper motions when examining an object with the naked eye, although the motions are directly opposite in the two cases. Indeed so natural does it become for the worker with the compound microscope to make the proper motions for the object giving the inverted image, that if he uses a compound microscope with an erecting prism he almost invariably moves the preparation in the wrong direction (§ 149a). With the simple microscope, however, it seems like naked-eye observation and there is never any difficulty.

This goes to show that by experience it is as easy to interpret inverted as erect images. This is further illustrated by the printer who learns to read type without difficulty, although it is a great puzzle to one who has only learned to read the appearances after the type has been printed on paper.

§ 218. **Summary for proper interpretation.** — To summarize this chapter and leave with the beginning student the result of the experience of many eminent workers:

(1) Get all the information possible with the unaided eye. See the whole object and all sides of it, so far as possible.

(2) Examine the preparation with a simple microscope in the same thorough way for additional detail.

(3) Use a low power of the compound microscope.

(4) Use a higher power.

(5) Make sure that the mirror is in the best position to give the most favorable light. Vary the aperture by opening and closing the iris diaphragm to find the aperture which gives the clearest image in each case.

(6) Shade the top of the stage of the microscope to cut off the light from above and thus avoid confusion from that source.

(7) Use the highest power available and applicable. In this way one sees the object as a whole and progressively more and more details.

(8) If one has the apparatus it is a good plan to examine specimens with a binocular microscope to gain the best notion possible of the relative position of parts of the specimen.

(9) Use the dark-ground illuminator (§ 210), the spectroscope, and polariscope (Ch. VIII).

(10) Try staining the preparations to be studied in various ways to bring out the structural details; remember also the advantage of a color picture over a pure refraction image (§ 137) and especially of a combined color and refraction image. Keep in mind also that the microscopic image cannot be expected to reveal structural details that are not in some way clearly differentiated in the specimen.

(11) If artificial light must be used, employ a screen of daylight glass (§ 92) between the source of illumination and the microscope; then one can obtain true color effects.

(12) The composite picture derived from all available means of observation is much more likely to be correct than that obtained by only one or two means of observation.

(13) According to Wright, p. 46, it is far more difficult to prepare and properly illuminate a specimen than to get a good image of it after it is thus prepared and lighted.

COLLATERAL READING FOR CHAPTER IV

For general discussions: Carpenter-Dallinger; A. E. Wright, *Principles of Microscopy*, Ch. V; Beale; Spitta, *Microscope*, Ch. XVIII; Chamot, *Chemical Microscopy*.

For pedesis see Jevons in *Quart. Jour. Science*, n.s., Vol. VIII (1878), p. 167; Rutherford, *Science*, N. S. Vol. XXX, 1909, pp. 289-302. For the original account of this see Robert Brown, "Botanical appendix to Captain King's voyage to Australia," Vol. II, p. 534 (1826).

For overcoming pedesis for photography see Gage, The use of a solution of gelatin to obviate pedesis in photographing milk globules and other minute objects in water, *Transactions Amer. Micr. Soc.*, Vol. XXIV, 1902, p. 21.

For figures (photo-micrographs, etc.) of the various forms of starch, see Bulletin No. 13 of the Chemical Division of the U. S. Department of Agriculture. For hair and wool, see Bulletin of the National Association of Wool Growers, 1875, p. 470; *Proc. Amer. Micro. Soc.*, 1884, pp. 65-68; Herzfeld, translated by Salter, *The technical testing of yarns and textile fabrics*, London, 1898.

For different appearances due to the illuminator, see Nelson, in *Jour. Roy. Micr. Soc.*, 1891, pp. 90-105; and for the illusory appearances due to diffraction phenomena, see Carpenter-Dallinger, p. 434; Mercer, *Trans. Amer. Micr. Soc.*, V. 18 p. 321-396; also, A. E. Wright's *Principles of Microscopy*, especially the first five chapters; and chapter IX and the appendix. Conrad Beck. *The Theory of the Microscope*. Cantor Lectures before the Royal Society of Arts, Nov. Dec., 1907. 59 pages, London, 1908.

CHAPTER V

MAGNIFICATION AND MICROMETRY

§ 225. Apparatus and material for Chapter V.

1. Simple and compound microscope (§ 228).
2. Block for magnifier and compound microscope (§ 230).
3. Steel scale or rule divided into millimeters and $\frac{1}{3}$ mm. (§ 231).
4. Dividers (§ 231).
5. Stage micrometer (§ 233).
6. Wollaston camera lucida (§ 234).
7. Ocular screw micrometers and fixed ocular micrometers (§ 238, 241).
8. Necturus red blood corpuscles (§ 248).
9. Eikonometer (§ 253).

WHY A MAGNIFIED IMAGE IS NECESSARY

§ 226. The fundamental reason for using a microscope lies in the structure of the eye and its possibilities of adjustment for objects at different distances.

The sensory receptors or neuro-epithelium (rods and cones) of the eye stand in general with their long axes parallel with the rays of light entering the eye, hence the image of any external object falls on the ends of the sensory receptors. Now it is believed that if any image falls wholly upon one of the receptors it will appear as a point, and if the image of two objects close together were to fall on one receptor the two objects would appear as one.

§ 227. Robert Hooke (1674), in dealing with the power of the human eye to distinguish double stars and to see two points or two details of an object as two, concluded that the two stars or the two points of any object must at be least far enough apart to make the visual angle one minute. A few people can distinguish double stars with a visual angle less than one minute, but for many people the visual angle must be greater. If the visual angle is too small, then the two stars or two points appear to fuse and form one. The visual angle of one minute then does not represent the limit of visibility, but the limit of resolution, that is, seeing two objects as two separate things.

Now as the visual angle under which any given object is seen depends upon its distance from the eye, and the power of accommodation for distance in the eye is limited, if very small objects are to be seen, or the parts of larger objects are to be distinguished as

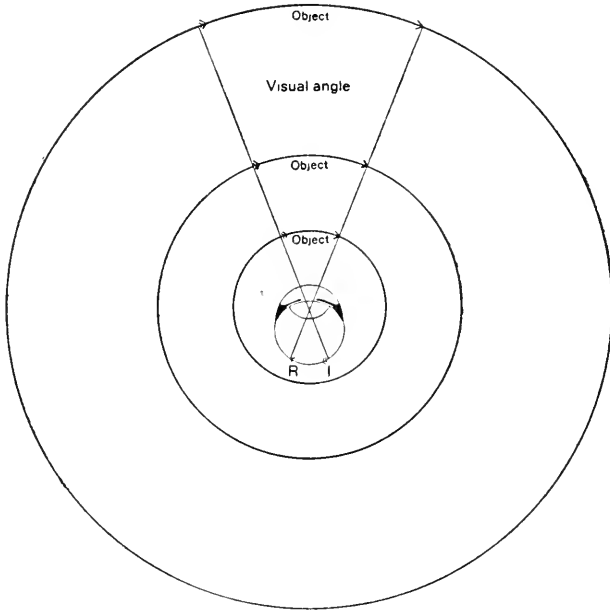

FIG. 75. CONSTANT RETINAL IMAGE (*R I*) AND CONSTANT VISUAL ANGLE WITH VARYING SIZE OF OBJECT AT DIFFERENT DISTANCES.

R I Retinal image. To keep this of constant size the visual angle must remain constant.

Object The object varying in size directly as the radius to keep the visual angle and the retinal image constant.

The radii in this figure are in the proportion of 1, 2, 4.

separate details, there must be some means of enabling the eye to get very close to the object.

The microscope serves to increase the visual angle under which an object is seen, thus virtually making it possible to get the eye very close to the object and still retain the sharpness of the retinal image.

Or to put it in another way, the microscope helps the eye to produce a larger retinal image, and makes the details large enough to fall on more than one of the retinal elements, thus making resolution possible.

The sensory receptors of the retina — the rods and cones — are quite close together and over the greater part of the retina are commingled, there being more rods than cones. In the region of greatest visual acuity (fovea centralis of macula lutea), only cones are present. In general the rods are $2\ \mu$ and the cones $6\ \mu$ in diameter. In the fovea, however, the cones are slender, being only about $2\ \mu$ or $3\ \mu$ in diameter. These sizes give a clue to the size the retinal image must have in order that there be resolution, that is, that two points appear as two or two lines appear as two.

If we assume that Hooke was correct in the assumption that for

two points to appear as two a visual angle of 1 minute is necessary, the diameter in millimeters or inches of the object, or the separation of the two points to render them visible as two, is easily determined as follows:

The nodal point or optic center of the eye is considered to be at the center of a circle (fig. 75), and the object at the circumference. No matter how great or how small the visual distance, the object must subtend one minute of the arc of the circle at whose circumference it

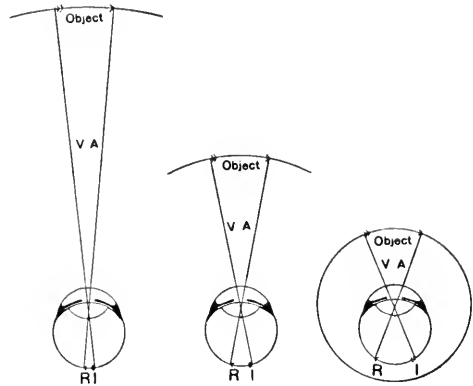

FIG. 76. CONSTANT SIZE OF OBJECT, THE VISUAL ANGLE AND THE RETINAL IMAGE VARYING WITH THE DISTANCE.

R I The retinal image varying inversely as the distance of the object.

V A The visual angle varying with the distance of the object from the eye.

Object The object of constant size but varying distance from the eye. The distance of the object is in the ratio of 1, 2, 4. The entire circle is shown at the right, but only a small arc in the other figures.

is situated, in order that its two extremities shall appear separate. And so with any two details; they must be far enough apart to make the visual angle one minute.

To determine the actual length in millimeters required to subtend one minute of arc in any case, it is only necessary to remember that the entire circumference is 6.2832 times its radius ($2\pi r$), and that this circumference is divided into 360° or 21,600 minutes.

If, now, the radius of the circle, or the distance of the eye from the object, is 1 meter, the circumference of the circle will be 6.2832 meters or 6283.2 millimeters. As there are 21,600 minutes in the entire circumference, the actual length of one minute with a circle having a radius of one meter is 6283.2 mm. divided by 21,600 equals 0.29088 mm. That is, the eye at one meter distance requires two points or two lines to be separated a distance of 0.29088 mm. in order that they may be seen as two and not appear to be fused together.

It is assumed by workers with the microscope that the distance of most distinct vision for adults when looking at objects for details of structure is 254 mm. or 10 inches. This is the standard distance selected for the determination of magnifying power in microscopy also.

The question now is, how large a retinal image will be formed by an object giving a visual angle of 1 minute at the standard distance of 254 mm.

First must be found the actual size of the object to give a visual angle of 1 minute at 254 mm. distance. It is known from the above calculation that for one meter or 1000 mm. the object must have a size of 0.29088 mm. Now for 254 mm. the length must be $\frac{2.54}{1000}$ of this number or 0.07388352 mm., that is, a little more than one-fourth the size at 1 meter.

Now to determine the size of the retinal image at 254 mm. image distance, the distance from the center or nodal point of the eye must be known as well as the image distance and the size of the object. The distance of the retinal image from the nodal point is assumed to be 15 mm. (Howell, p. 306); then the size of the retinal image will be: $0.07388352 : x :: 254 : 15 = 0.00436$ mm. or 4.36μ , and this size would

make the image fall on at least two of the cones of the fovea, and therefore there would be resolution and any two points would appear as two and not as one.

MAGNIFICATION

§ 228. The magnification, amplification, or magnifying power of a simple or compound microscope is the ratio between the apparent and real size of the object examined. The apparent size is obtained by measuring the virtual image (fig. 77-78). For determining magnification the object must be of known length and is designated a micrometer (§ 233). In practice a virtual image is measured by the aid of some form of camera lucida (fig. 81, 100), or by double vision (§ 230). As the length of the object is known, the magnification is easily determined by dividing the size of the image by the size of the object. For example, if the virtual image measures 40 mm. and the object magnified, 2 mm., the amplification is $40 \div 2 = 20$, that is, the apparent size is twentyfold greater than the real size.

Magnification is expressed in diameters or times linear; that is, but one dimension is considered. In giving a scale at which a microscopical or histological drawing is made, the word "magnification" is frequently indicated by the sign of multiplication: thus, $\times 450$ upon a drawing means that the figure

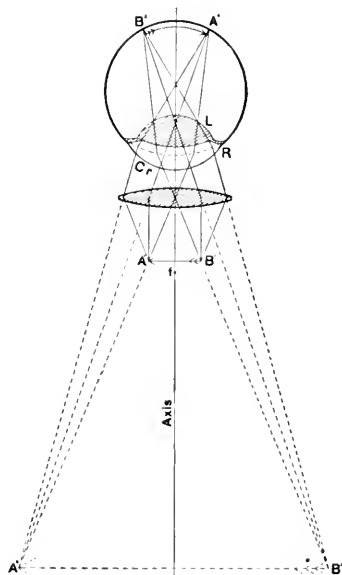

FIG. 77. SIMPLE MICROSCOPE WITH THE VIRTUAL IMAGE AT 250 MM. FROM THE EYE.

Axis The principal optic axis of the microscope and of the eye.

f The principal focus of the microscope.

A B The object just above the focus (*f*).

B² A² The retinal image; it is inverted.

A³ B³ The virtual image at 250 mm. from the eye; it is erect.

Cr Cornea of the eye.

R Single refracting surface of the schematic eye.

L The crystalline lens of the eye.

Axis The principal optic axis of the microscope and of the eye.
f, f Principal focus of the objective, and of the ocular, *r im*, the real image formed by the objective just above the principal focus of the ocular.
cr The cornea of the eye.
rs The single refracting
l The crystalline lens of
ri The retinal image; it
 The tube length of the microscope, and the image distance 250 millimeters. For more fig. 20.

surface of the schematic eye. the eye. is erect. microscope (fig. 25) is 160 millimeters of the virtual image, complete explanation see

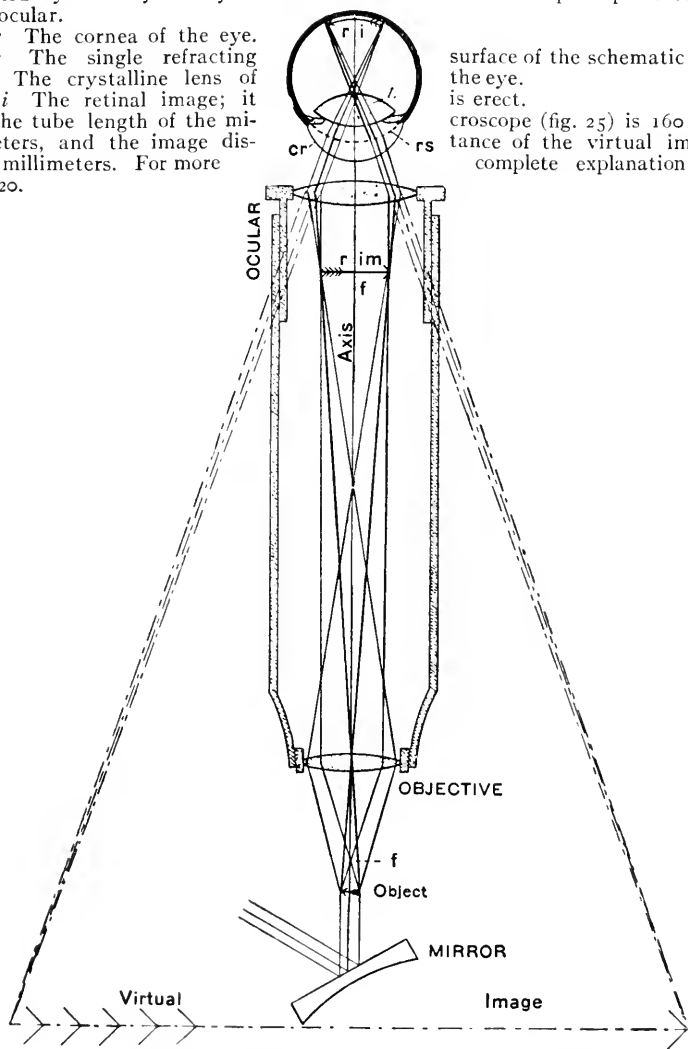

FIG. 78. COMPOUND MICROSCOPE SHOWING ALL THE IMAGES.

or drawing has the width or length of every detail 450 times as great as the object.

§ 229. **Magnification of real images.** — In this case the magnification is the ratio between the size of the real image and the size of the object, and the size of the real image can be measured directly. By recalling the work on the function of an objective, it will be remembered that it forms a real image on the ground-glass placed on the top of the tube, and that this real image could be looked at with the eye or measured as if it were an actual object. For example, suppose the object were three millimeters long and its image on the ground-glass measured 15 mm., then the magnification is $15 \div 3 = 5$, that is, the real image is 5 times as long as the object. The real images seen in photography are mostly smaller than the objects, but the magnification is designated in the same way by dividing the size of the real image measured on the ground-glass by the size of the object. For example, if the object is 400 millimeters long and its image on the ground-glass is 25 millimeters long, the ratio is $25 \div 400 = \frac{1}{16}$. That is, the image is $\frac{1}{16}$ as long as the object and is not magnified but reduced. In marking negatives, as with drawings, the sign of multiplication is put before the ratio, and in the example the designation is $\times \frac{1}{16}$. In photography (Ch. VII) and when using the magic lantern and the projection microscope the images are real, and may be measured on the screen as if real pictures (fig. 79).

§ 230. The magnification of a simple microscope is the ratio between the virtual image (fig. 6, 77, A^3B^3) and the object magnified (A^1B^1). To obtain the size of this virtual image, place the tripod magnifier near the edge of a support or block of such a height that the distance from the upper surface of the magnifier to the table is 250 millimeters.

As object, place a scale of some kind ruled in millimeters on the support under the magnifier. Put some white paper on the table at the base of the support and on the side facing the light.

Close one eye, and hold the head so that the other will be near the upper surface of the lens. Focus if necessary to make the image clear. Open the closed eye and the image of the rule will appear as if on the paper at the base of the support. Hold the head very still, and with

dividers get the distance between any two lines of the image. This is the so-called method of double vision in which the microscope image is seen with one eye and the dividers with the other, the two images appearing to be fused in a single visual field.

§ 231. **Measuring the spread of the dividers.** — This should be done on a steel scale divided to millimeters and $\frac{1}{5}$ mm.

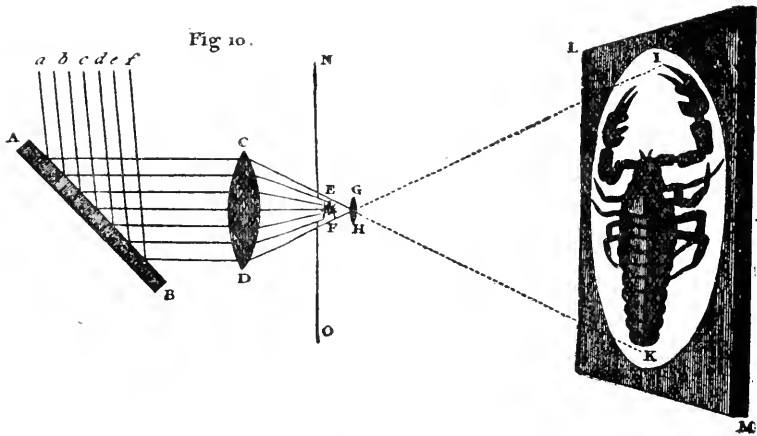

FIG. 79. REAL IMAGE FORMED BY A PROJECTION MICROSCOPE.

(From the Essays of George Adams).

- A B* Mirror reflecting the parallel rays of the sun upon the condenser (*C D*).
- a b c d e f* Parallel beams of light.
- C D* The condenser.
- N O* The stage of the projection apparatus.
- E F* The object.
- G H* The projection objective.
- L M* The screen upon which the real image is shown.
- I K* The real image of the object (*E F*).

As $\frac{1}{5}$ mm. cannot be seen plainly by the unaided eye, place one arm of the dividers at a centimeter line, and with the tripod magnifier count the number of spaces on the rule included between the points of the dividers. The magnifier simply makes it easy to count the space on the rule included between the points of the dividers — it does not, of course, increase the number of spaces or change their value.

As the distance between the points of the dividers gives the size of

the virtual image (fig. 77), and as the size of the object is known, the magnification is determined by dividing the size of the image by the size of the object. Thus, suppose the distance between the two lines at the limits of the image is measured by the dividers and found on the steel scale to be 15 millimeters, and the actual size of the space between the two lines of the object is 2 millimeters, then the magnification is $15 \div 2 = 7.5$; that is, the image is 7.5 times as long or wide as the object. In this case the image is said to be magnified 7.5 diameters, or 7.5 times linear.

The magnification of any simple magnifier may be determined experimentally in the way described for the tripod magnifier; but this

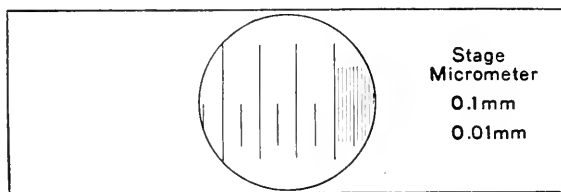

FIG. 80. STAGE MICROMETER RULED ON A COVER-GLASS.

The tenths millimeter (0.1 mm.) spaces are divided by short lines making the whole micrometer one with 0.1, 0.05, and 0.01 millimeters.

method is of course only possible when the observer has two good eyes. If he has but one eye, or his eyes are very unlike, then the magnification can be determined with one eye by using a camera lucida or the eikonometer (§ 234, 253).

§ 232. The magnification of a compound microscope is the ratio between the final or virtual image and the object magnified.

The determination of the magnification of a compound microscope may be made as with a simple microscope (§ 230), but this is fatiguing and unsatisfactory.

§ 233. **Stage, or object micrometer.** — For determining the magnification of a compound microscope and for the purposes of micrometry, it is necessary to have a finely divided scale or rule on glass or on metal. Such a finely divided scale is called a micrometer, and for ordinary work one mounted on a glass slide (1 × 3 in., 25 × 76 mm.) is most convenient.

The spaces between the lines should be 0.1 and 0.01 mm. (or in inches, 0.01 and 0.001 in.). Micrometers are sometimes ruled on the

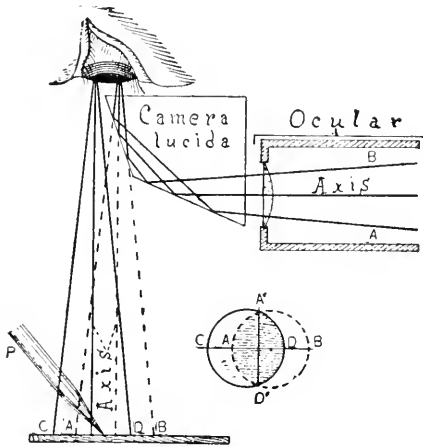

FIG. 81. WOLLASTON'S CAMERA LUCIDA.

slide, but more satisfactorily on a cover-glass of known thickness, preferably 0.15–0.18 mm. The covers should be perfectly clean before ruling, and afterwards simply dusted off with a camel's hair duster, and then mounted, lines downward over a shellac or other good cell (see Ch. X). If one rubs the lines the edges of the furrow made by the diamond are liable to be rounded and the sharpness of the micrometer is lost. If the lines are on the slide and uncovered one cannot use the micrometer with an oil immersion, as the oil obliterates the lines. Cleaning the slide makes the lines less sharp, as stated. If the lines are coarse, it is an advantage to fill them with plumbago or graphite. This may be done with some very fine plumbago on the end of a soft cork, or by using a soft lead pencil. Lines properly filled may be covered with balsam and a cover-glass as in ordinary balsam mounting (Ch. X).

§ 234. **Determination of magnification.**—This is most readily accomplished by the use of some form of camera lucida, that of Wollaston being most convenient, as it may be used for all powers, and the determination of the standard distance of 250 millimeters at which to measure the images is readily accomplished (fig. 81).

Employ the 16 mm. objective and a 4x or 5x ocular with a stage

slide, but more satisfactorily on a cover-glass of known thickness, preferably 0.15–0.18 mm. The covers should be perfectly clean before ruling, and afterwards simply dusted off with a camel's hair duster, and then mounted, lines downward over a shellac or other good cell (see Ch. X). If one rubs the lines the edges of the furrow made by the diamond are liable to be rounded and the sharpness of the micrometer is lost. If the lines are on the

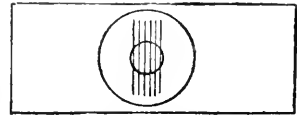

FIG. 82. STAGE MICROMETER WITH A RING ON THE LINES.

micrometer as object. For this power the 0.1 mm. spaces of the micrometer should be used as object. Focus sharply.

It is somewhat difficult to find the micrometer lines. To avoid this it is well to have a small ring enclosing some of the micrometer lines (fig. 82). The light must also be carefully regulated. If too much light is used, i.e., too large an aperture, the lines will be drowned in the light. In focusing with the high powers be very careful. Remember the micrometers are expensive and one cannot afford to break them. As suggested above, focus on the edge of the cement ring enclosing the lines; then, in focusing down to find the lines, move the preparation very slightly, back and forth. This will bring the lines into the field and the shadow made by them will indicate their presence, and one can then focus until they are sharp.

After the lines are sharply focused, and the slide clamped in position, make the tube of the microscope horizontal, by bending the flexible pillar, being careful not to bring any strain upon the fine adjustment (fig. 25).

Put a Wollaston camera lucida (fig. 81) in position, and turn the ocular around if necessary so that the broad flat surface may face directly upward, as shown in the figure. Elevate the microscope by putting a block under the base, so that the perpendicular distance from the upper surface of the camera lucida to the table is 250 mm. (§ 236). Place some white paper on the work-table beneath the camera lucida.

Close one eye, and hold the head so that the other may be very close to the camera lucida. Look directly down. The image will appear to be on the table. It may be necessary to readjust the focus after the camera lucida is in position. If there is difficulty in seeing both dividers and image, consult Ch. VI. Measure the image with dividers and obtain the power exactly as above (§ 231).

Thus: suppose two of the 0.1 mm. spaces were taken as object and the image is measured by the dividers, and the spread of the dividers is found on the steel rule to be 9.4 millimeters, the magnification (which is the ratio between size of image and object) is $9.4 \div 0.2 = 47$. That is, the magnification is 47 diameters, or 47 times linear.

Put the 8x or 10x ocular in place of the 4x or 5x, and then put the camera lucida in position. Measure the size of the image with dividers and a rule as before. The power will be considerably greater than when the low ocular was used. This is because the virtual image (fig. 78) seen with the high ocular is larger than the one seen with the low one.

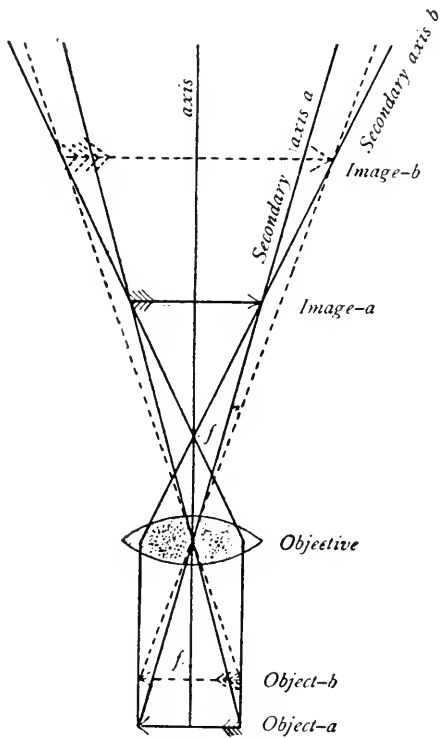

FIG. 83. TO SHOW THE RELATIVE POSITION OF THE OBJECT AND THE REAL IMAGE.

The farther from the lens the object, the nearer to it will be the real image (*Object-a*, *Image-a*; and *Object-b*, *Image-b*).

axis The principal optic axis extended above and below.

Secondary axis a and b The secondary axes at the limits of the respective images, and objects.

The law is: the magnification varies directly with the relative distance of the image and object from the center of the lens (fig. 84); thus, if the image is four times as far from the center of the lens as the object, then it will be four times as large as the object, and if it is one-fourth as far from the center of the lens as the object it will be only one-fourth as big as the object, and so on.

§ 235. **Varying the magnification of a microscope.** — There are five ways of varying the power of a compound microscope:

- (1) By using a higher or lower objective.
- (2) By using a higher or lower ocular.
- (3) By lengthening or shortening the tube of the microscope.
- (4) By increasing or diminishing the distance at which the virtual image is projected (fig. 85).

(5) By changing the relative position of the combinations in an adjustable objective (§ 31, 134) or by the use of an amplifier (§ 235a).

§ 235a. **Amplifier.** — In addition to the methods of varying the magnification given in § 235, the magnification is sometimes increased by the use of an amplifier, that is, a diverging lens or combination placed between the objective and ocular and serving to give the image-forming rays from the objective an increased divergence. An effective form of this accessory was made by Tolles, who made it as a small achromatic concavo-convex lens to be screwed into the lower end of the draw-tube (fig. 25) and thus but a short distance above the objective. The divergence given to the rays usually increases the size of the real image about twofold.

§ 236. **Standard distance at which the virtual image is measured.** — For obtaining the magnification of both the simple and the compound microscope the directions were to measure the virtual image at a distance of 250 millimeters. This is because some standard distance must be chosen so that different workers can compare their results. The magnification could be found at almost any distance, and in getting the magnification of drawings the image distance is rarely exactly 250 millimeters. Whenever the magnification of the microscope as a whole or of the objective or the ocular is mentioned, however, it is

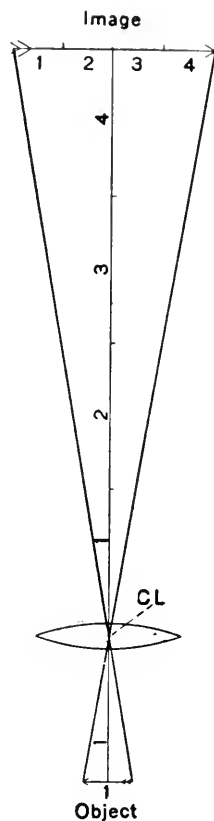

FIG. 84. TO SHOW THAT THE SIZE OF THE REAL IMAGE DEPENDS UPON ITS RELATIVE DISTANCE FROM THE CENTER OF THE OBJECTIVE.

Object 1 The object one unit of distance from the center of the lens (CL).

Image 1, 2, 3, 4 The image four units of distance from the lens and hence four times as long as the object.

always understood that this magnification is at the standard distance of 250 mm. The necessity for the adoption of some common standard will be seen at a glance in fig. 85, where is represented graphically the fact that the size of the virtual image depends directly on the distance at which it is projected, and this size is directly proportional to the vertical distance from the apex of the triangle, of which

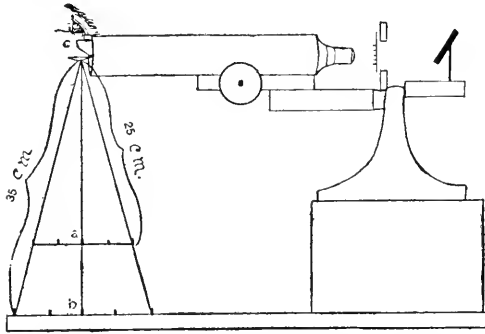

FIG. 85. DIAGRAM TO SHOW THAT THE SIZE OF THE VIRTUAL IMAGE DEPENDS UPON THE PROJECTION DISTANCE.

a Size of image at a projection distance of 25 cm.

b Image at 35 cm.

The sizes are directly as the projection distances.

C The camera lucida and under it a spectacle lens to aid the eye in focusing the pencil point; this is only needed by those with defective eyes.

it forms a base. The distance of 250 millimeters has been chosen on the supposition that it is the distance of most distinct vision for normal adults when examining details.

In preparing drawings it is often of great convenience to make them at a distance less or greater than the standard. In that case the magnification must be determined for the image distance actually used.

237. Magnification and relation of the object to the principal focus. — As shown by figures 86 and 87, independent of the equivalent focus of the simple microscope or the objective, the real image or the virtual image, as the case may be, will be larger the nearer the object is to the principal focal point.

In figures 88 and 89 it is shown also that if the object or the real image is in the plane of the principal focus, the rays emerging from the simple microscope or the ocular will be in parallel bundles, and when projected by the eye must also be in parallel bundles. It is further shown in such a case that the rays emanating from any point in the object or real image will not in that case form a virtual point

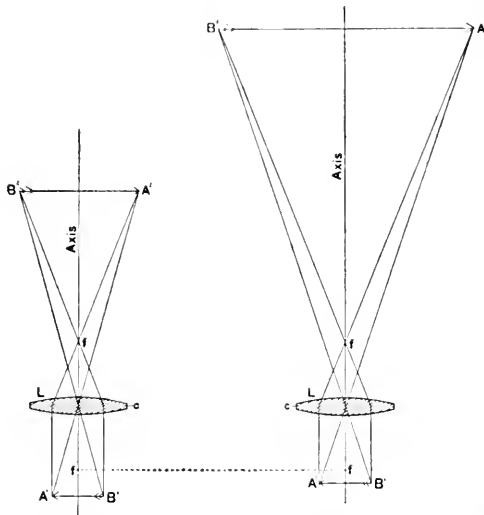

FIG. 86. DIAGRAMS TO SHOW THAT THE SIZE OF THE REAL IMAGE OF A LENS DEPENDS UPON THE DISTANCE OF THE OBJECT FROM THE PRINCIPAL FOCUS.

Axis The principal optic axis extended above and below. *AB, B'A'* The object and the inverted real image. *f, f* The principal focus above and below each lens. *Lc* The lens.

The object is the same size in the two cases, but the images differ, depending upon the distance of the object from the principal focus, being longer the nearer the object is to the focus.

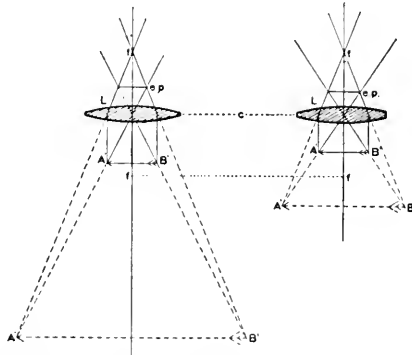

FIG. 87. DIAGRAM TO SHOW THAT THE SIZE OF THE VIRTUAL IMAGE OF A LENS DEPENDS UPON THE DISTANCE OF THE OBJECT FROM THE PRINCIPAL FOCUS.

AB, A'B' The object and the virtual image. *f, f* The principal focus. *L* The lens. *ep* The eye-point. *c* The single, ideal refracting plane.

As with real images, the size of virtual image in a given lens depends upon the nearness of the object to the principal focus.

focus at the standard distance of 250 mm., as shown in fig. 77, but will remain parallel. At that distance then the image on the retina would be a diffusion circle. In order that there be the appearance of a point focus the distance must be great enough so that the parallel rays from a point will be separated less than one minute (§ 226-227).

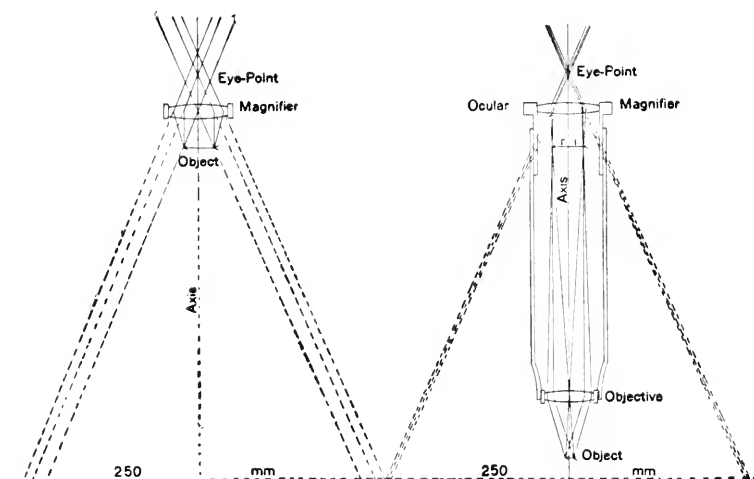

FIG. 88-89. DIAGRAMS OF SIMPLE AND COMPOUND MICROSCOPES WITH PARALLEL BEAMS EMERGING ABOVE AND PROJECTED BELOW.

Axis The principal optic axis.

Object The object.

Objective The objective of the compound microscope.

r i The real image formed by the objective.

Ocular-Magnifier The ocular and magnifier for the real image in the compound microscope, and for the object in the simple microscope.

Eye-point The most favorable position for the eye of the observer.

Below, at 250 mm., the usual position of the projected image, no image is formed with parallel rays. These only seem to come from a point at a distance where their separation is less than one minute (§ 226-227).

Table of magnification and of the valuations of the ocular micrometer. — The table should be filled out by each student. In using it for Micrometry and Drawing it is necessary to keep clearly in mind the exact conditions under which the determinations were made, and also the ways in which variations in magnification and the valuation of the ocular micrometer may be produced.

OBJECTIVE	OCULAR 4x or 5x		OCULAR 8x or 10x		OCULAR MICROMETER VALUATION	
	TUBE IN	TUBE OUT — MM.	TUBE IN	TUBE OUT — MM.	TUBE IN.	OUT—MM.
	×	×	×	×		
	×	×	×	×		
	×	×	×	×		
	×	×	×	×		
	×	×	×	×		
	×	×	×	×		
SIMPLE MICROSCOPE.		×				

OCULAR MICROMETER AND ITS VALUATION

§ 238. This, as the name implies, is a micrometer to be used in connection with an ocular. It consists of rulings on a cover-glass of fixed or of movable lines.

This form of micrometer is placed at the level where the real image is formed, i.e., at the level of the ocular diaphragm of all oculars. With positive oculars it would therefore be outside the ocular (fig. 22) and with negative or Huygenian oculars between the lenses (fig. 23-24). The image of the object under the microscope appears to be directly upon or immediately under the ocular micrometer, and hence the number of spaces on the ocular micrometer required to measure the real image may be read off directly. This, however, is measuring the size of the real image, and the actual size of the object can only

be determined by determining the ratio between the size of the real image and the object. In other words, it is necessary to get the valuation of the ocular micrometer in terms of a stage micrometer.

§ 239. **Valuation of the ocular micrometer.** — This is the value of the divisions of the ocular micrometer for the purposes of micrometry, and is entirely relative, depending on the magnification of the real image formed by the objective; consequently it changes with every change in the magnification of the real image, and must be especially determined for every change modifying the real image of the microscope (§ 235).

It will be seen when the ocular micrometer valuation is found for different objectives, that the greater the magnification of the objective the less will be the ocular micrometer valuation; and conversely, the less the magnification of the objective the greater will be the ocular micrometer valuation.

§ 240. **Obtaining the ocular micrometer valuation for an ocular micrometer with fixed lines.** — If the ocular micrometer is on a cover-glass, place it on the diaphragm of the 5x or 10x ocular after removing the eye-lens. Screw the eye-lens back in place, and put the ocular in the tube of the microscope. Put a 16 mm. objective in place. Use the stage micrometer as object. Light the field well and look into the microscope. The lines of the ocular micrometer should be very sharply defined. If they are not, raise or lower the eye-lens to make them so; that is, focus as with the simple magnifier.

When the lines of the ocular micrometer are distinct, focus the microscope (§ 234) for the stage micrometer. The image of the stage micrometer appears to be directly under or upon the ocular micrometer.

Make the lines of the two micrometers parallel by rotating the ocular or changing the position of the stage micrometer or both if necessary, and then make any two lines of the stage micrometer coincide with any two on the ocular micrometer (fig. 90). To do this it may be necessary to pull out the draw-tube a greater or less distance. See how many spaces are included in each of the micrometers (see fig. 90, 98).

Divide the value of the included space or spaces on the stage microm-

eter by the number of divisions on the ocular micrometer required to include them, and the quotient so obtained will give the valuation of the ocular micrometer. For example, suppose the millimeter is taken as the unit for the stage micrometer and this unit is divided into spaces of 0.1 and 0.01 millimeters. If with a given optical combination and tube-length it requires 10 spaces on the ocular micrometer to include the real image of 0.1 millimeter on the stage micrometer, obviously one space on the ocular micrometer includes only one-tenth as much, or 0.1 mm. $\div 10 = 0.01$ mm. That is, each space on the ocular micrometer includes 0.01 of a millimeter on the stage micrometer, or 0.01 millimeter of the length of any object under the microscope, the conditions remaining the same. Or, in other words, it requires 100 spaces on the ocular micrometer to include 1 millimeter on the stage micrometer; then, as before, 1 space of the ocular micrometer would have a valuation of 0.01 millimeter for the purposes of micrometry. The size of any minute object may be determined by multiplying this valuation of one space by the number of spaces required to include it. For example, suppose the fly's wing or some part of it covered 8 spaces on the ocular micrometer; it would be known that the real size of the part measured 0.01 mm. $\times 8 = 0.08$ mm. or 80μ (§ 246).

Proceed in exactly the same manner to get the ocular micrometer valuation when using any objective whether it is of higher or lower power than the one in this section.

Any Huygenian ocular may be used as a micrometer ocular by placing the ocular micrometer at the level of the ocular diaphragm where the real image is formed. If there is a slit in the side of the

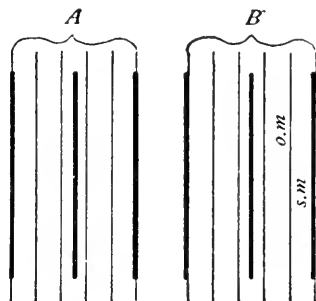

FIG. 90. THE IMAGES OF THE OCULAR AND OF THE STAGE MICROMETER, SHOWING HOW TO ARRANGE THE LINES.

o.m Ocular, *s.m* Stage micrometer lines.

A Lines of the ocular micrometer opposite the middle of the lines of the stage micrometer.

B Lines of the ocular micrometer at the right side of the lines of the stage micrometer (compare fig. 98).

ocular and the ocular micrometer is mounted properly it may be introduced through the opening in the side. This was a common method with the older microscopes. When there is no side opening the eye-lens may be unscrewed and the ocular micrometer on a cover-glass laid upon the ocular diaphragm.

OCULAR MICROMETER WITH MOVABLE SCALE

§ 241. This form is a Huygenian ocular with a five millimeter scale divided into twenty one-fourth millimeter intervals. The

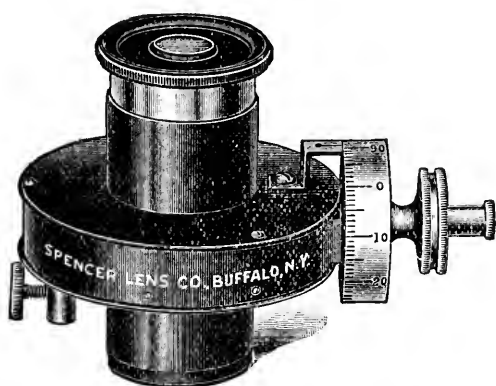

FIG. 91. OCULAR MICROMETER WITH MOVABLE SCALE AND RECORDING DRUM.

(From the Catalogue of the Spencer Lens Co.).

The recording drum is divided into 100 equal divisions.

This ocular micrometer combines the advantages of the ocular micrometer with a fixed scale and the filar micrometer. To complete the measurement of an object not exactly included between any two lines of the scale, the drum need be revolved only partly around.

§ 242. Valuation of the movable scale ocular micrometer (fig. 91). — Use a 4 mm. objective and proceed exactly as for the micrometer with fixed lines, except that a partial stage micrometer space can be measured by rotating the drum until the ocular micrometer exactly coincides with the stage micrometer. Make sure that the lines of the two micrometers are correctly related, as shown in fig. 90 and 98. One

pitch of the screw moving the scale is $\frac{1}{4}$ mm.; therefore one complete revolution of the drum moves the scale one-fourth of a millimeter, or one interval. The drum is divided into 100 equal divisions, thus enabling one to measure $\frac{1}{100}$ of an interval on the micrometer scale.

can then count up the number of spaces on the ocular micrometer required to measure one or more spaces of the stage micrometer. To this is then added the $\frac{1}{100}$ spaces on the drum. For example suppose that three 0.01 mm. spaces of the stage micrometer are taken as object, and that it requires seven complete spaces of the ocular micrometer and $\frac{50}{100}$ on the drum to include the three spaces on the stage micrometer; then each space on the ocular micrometer would be equal to 0.03 mm. divided by 7.50 = 0.004 mm. or 4 μ . One of the spaces on the drum which represents one-hundredth of an interval on the ocular micrometer would have a valuation under these conditions of 4 μ divided by 100 = 0.04 microns. This gives a notion of the minuteness of the object which can be measured, and of the smallness of the error in measuring large objects, even if the observation erred in getting the object one or more of the drum divisions too large or too small.

For an actual measurement with this ocular micrometer, see (§ 251).

One would proceed exactly as above for getting the valuation with any other objective.

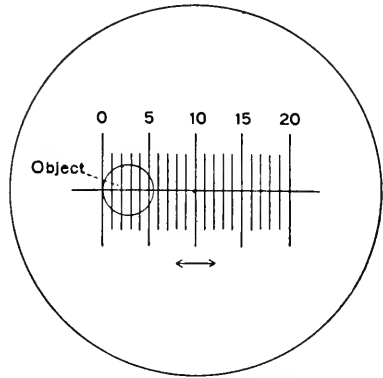

FIG. 92. FIELD OF THE MICROSCOPE SHOWING THE MOVABLE SCALE OF THE HUYGENIAN MICROMETER OCULAR (FIG. 91).

The arrow indicates that the scale may be moved in both directions.

0, 5, 10, 15, 20 These figures indicate the 20 spaces in groups of 5. Each space represents a total revolution of the screw (screw with $\frac{1}{4}$ mm. pitch). Each of the 100 divisions on the drum (fig. 91) represents then $\frac{1}{400}$ mm.

Object A circular object covering five of the micrometer spaces, and the drum shows 45 division to measure the partial space; the entire object then measures 5.45 divisions.

FILAR OCULAR MICROMETER

§ 243. This form of ocular micrometer usually consists of a Ramsden ocular with fixed cross lines and a movable line (fig. 94).

For obtaining the valuation of this ocular micrometer proceed as follows: Employ a 4 mm. objective. Carefully focus the $\frac{1}{100}$ mm. lines. The lines of the ocular micrometer should also be sharp; if they are not focus them by moving the ocular up or down in the sliding tube. Make the vertical lines of the ocular micrometer parallel with the lines of the stage micrometer (fig. 90, 98). Note the position of the graduated drum and the teeth of the recording comb, and then rotate the wheel until the movable line traverses one space on

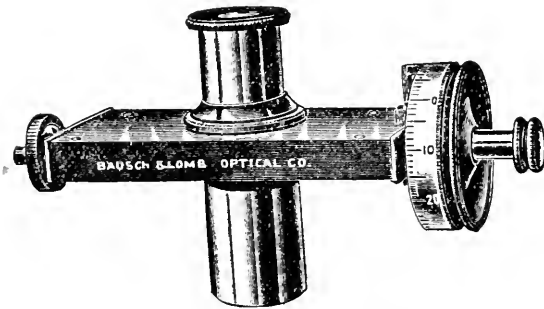

FIG. 93. FILAR MICROMETER OCULAR.

(From the 16th ed. of the Catalogue of the Bausch & Lomb Optical Co.).

This is a Ramsden ocular, and the recording drum is divided into 100 equal divisions, and as the pitch of the screw is 0.5 mm., each division on the drum represents an actual movement of 0.005 mm. of the movable line.

Measure in like manner 4 or 5 spaces and get the average. Suppose this average is $1\frac{1}{4}$ revolutions or 125 graduations on the wheel, to measure the 0.01 mm. or $10\ \mu$ (see § 246), then one of the graduations on the wheel would measure $10\ \mu$ divided by $125 = 0.08\ \mu$. In using this valuation for actual measurement, the tube of the microscope and the objective must be exactly as when obtaining the valuation (see § 235-242).

The valuation of the filar micrometer can be obtained for any objective by proceeding exactly as above (see § 252 for measurement).

the stage micrometer. Each tooth of the recording comb indicates a total revolution of the wheel, and by noting the number of teeth required and the graduations on the wheel, the revolutions and part of a revolution required to measure the 0.01 mm. of the stage micrometer can be easily noted.

MICROMETRY

§ 244. Micrometry is the determination of the size of objects by the aid of a microscope.

MICROMETRY WITH THE SIMPLE MICROSCOPE

§ 245. With a simple microscope (*i*), the easiest and best way is to use dividers and then with the simple microscope determine when the points of the dividers exactly include the object. The spread of the dividers is then obtained as above (§ 230-231). This amount will be the actual size of the object, as the microscope was only used in helping to see when the divider points exactly enclosed the object.

(2) One may put the object under the simple microscope and then, as in determining the power (§ 230), measure the image at the standard distance. If the size of the image so measured is divided by the magnification of the simple microscope, the quotient gives the actual size of the object. One might use the eikonometer also (§ 254).

Use a fly's wing or some other object of about that size and try to determine the width in the two ways described above. If all the work is accurately done the results will agree.

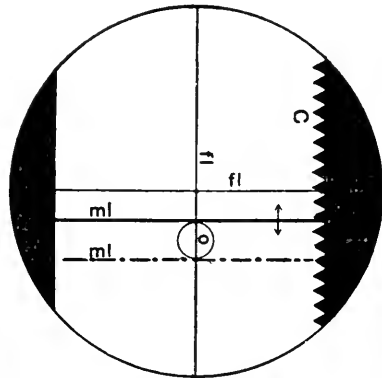

FIG. 94. FIELD OF THE MICROSCOPE SHOWING THE LINES AND THE RECORDING COMB OF THE FILAR MICROMETER (FIG. 93).

C The recording comb. Each tooth represents a complete revolution of the drum (fig. 93).

fl, fl The fixed cross lines.

ml, ml The movable line.

The arrow shows that the movable line can be moved in both directions.

O Object, the full movable line (*ml*) shows it at one edge of the object and the broken line shows it at the other edge of the object. The intervening teeth of the comb show that the screw was turned two whole revolutions and the recording drum showed 90 divisions, making two and nine tenths revolutions of the drum to carry the movable line from one edge of the object to the other.

MICROMETRY WITH THE COMPOUND MICROSCOPE

There are several ways of varying excellence for obtaining the size of objects with the compound microscope, the method with the ocular micrometer (§ 238) being most accurate.

§ 246. **Unit of measure in micrometry.** — As most of the objects measured with the compound microscope are smaller than any of the originally named divisions of the meter, and the common or decimal fractions necessary to express the size are liable to be unnecessarily cumbersome, Harting, in his work on the microscope (1859), proposed the one-thousandth of a millimeter (0.001 mm.) or one-millionth of a meter (0.000001 meter) as the unit. He named this unit micromillimeter and designated it mmm. In 1869, Listing (Carl's Repertorium für Experimental-Physik, Bd. X, p. 5) favored the thousandth of a millimeter as unit and introduced the name mikron or micrum. In English it is most often written Micron (plural micra or microns, pronunciation Mik'rōn or Mik'rōn). By universal consent the sign or abbreviation used to designate it is the Greek μ . Adopting this unit and sign, one would express five-thousandths of a millimeter (0.005 mm.) thus, 5μ .

§ 246a. The term "micromillimeter," abbreviation mmm., is very cumbersome, and besides is entirely inappropriate, since the adoption of the definite meanings for the prefixes micro and mega, meaning respectively one-millionth and one million times the unit before which it is placed. A micromillimeter would then mean one-millionth of a millimeter, not one-thousandth. The term "micron" has been adopted by the great microscopical societies, the international commission on weights and measures, and by original investigators, and is, in the opinion of the writer, the best term to employ. Jour. Roy. Micr. Soc., 1888, p. 502; Nature, Vol. XXXVII (1888), p. 388.

§ 247. **Micrometry by the use of a stage micrometer on which to mount the object.** — In this method the object is mounted on a micrometer and then put under the microscope, and the number of spaces covered by the object is read off directly. It is exactly like putting any large object on a rule and seeing how many spaces of the rule it covers. The defect in the method is that it is impossible to properly arrange objects on the micrometer. Unless the objects are circular in outline they are liable to be oblique in position, and in every case the end or edges of the object may be in the middle of a

space instead of against one of the lines, consequently the size must be estimated or guessed at rather than really measured.

§ 248. **Micrometry by dividing the size of the image by the magnification of the microscope.** — For example, employ the 4 mm. objective, and 8x or 10x ocular. For measurement use a preparation of the blood corpuscles of the frog, necturus, or other animal with large oval corpuscles. Obtain the size of the image of the long and short axes of three corpuscles with the camera lucida and dividers, exactly as in obtaining the magnification of the microscope (§ 234). Divide the size of the image in each case by the magnification, and the result gives the actual size of the blood corpuscles. Thus, suppose the image of the long axis of the corpuscle is 18 mm. and the magnification of the microscope 400 diameters (§ 228), then the actual length of this long axis of the corpuscle is $18 \text{ mm.} \div 400 = 0.045 \text{ mm.}$ or 45μ (§ 231).

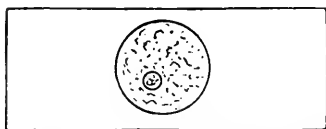

FIG. 95. BLOOD PREPARATION WITH A RING AROUND A GROUP OF CORPUSCLES.

As the same three blood corpuscles are to be measured in three ways, it is an advantage to put a delicate ring around a group of three or more corpuscles, and make a sketch of the whole enclosed group, marking on the sketch the corpuscles measured (fig. 95). The different corpuscles vary considerably in size, so that accurate comparison of different methods of measurement can only be made when the same corpuscles are measured in each of the ways.

§ 249. **Micrometry by the use of a stage micrometer and a camera lucida.** — Employ the same object, objective, and ocular as before. Put the camera lucida in position, and with a lead pencil make dots on the paper at the limits of the image of the blood corpuscles. Measure the same three that were measured in § 248.

Remove the object, place the stage micrometer under the microscope, focus well, and draw the lines of the stage micrometer so as to include the dots representing the limits of the part of the image to be measured. As the value of the spaces on the stage micrometer is known, the size of the object is determined by the number of spaces of the micrometer required to include it.

This simply enables one to put the image of a fine rule on the image of a microscopic object. It is theoretically an excellent method, and nearly the same as measuring the spread of the dividers with a simple microscope (§ 231).

§ 250. **Micrometry with the ocular micrometer with fixed lines.** — Use the 4 mm. objective, and the ocular with the ocular micrometer. For object use the same corpuscles as in § 248–249. Make sure that all the conditions are exactly as when the valuation was determined; then put the preparation under the microscope and find the same three red corpuscles that were measured in the other ways (§ 248).

Count the divisions on the ocular micrometer required to enclose or measure the long and the short axis of each of the corpuscles, multiply the number of spaces in both cases by the valuation of the ocular micrometer, and the results will represent the actual length of the axes of the corpuscles in each case.

The same corpuscle is, of course, of the same actual size, when measured in each of the three ways, so that if the methods are correct and the work carefully enough done, the same results should be obtained by each method.

§ 251. **Micrometry with the movable scale ocular micrometer.** — Use the same preparation and objective as before. Arrange the micrometer ocular so that the long axis of the corpuscle will coincide with the cross line in the micrometer scale (fig. 91–92). Get one end of the corpuscle exactly level with one division of the micrometer scale. Note the position of the drum, and then rotate it until the other end of the corpuscle is exactly against the nearest line of the micrometer. Count up the entire intervals required and the partial interval on the drum. Suppose it requires 5 entire and 0.60 intervals (see explanation of fig. 92); then the whole corpuscle must be 5.60 intervals multiplied by 4μ (§ 242) the value of one interval; $5.6 \times 4 = 22.4\mu$.

§ 252. **Micrometry with the filar micrometer.** — Use the same preparation and objective as before, but use a filar micrometer. Note how many graduations on the recording comb and drum (fig. 93) are required to measure each dimension of the corpuscle, and multiply by the valuation as in the other cases.

The advantage of the filar micrometer is that the valuation of one graduation is so small that even the smallest object to be measured would require several graduations to measure it. In ocular micrometers with fixed lines, small objects like bacteria might not fill even one space; therefore estimations, not measurements, must be made. For large objects, like most of the tissue elements, the ocular micrometers with fixed lines answer very well, for the part which must be estimated is relatively small and the chance of error is correspondingly small (§ 252a).

§ 252a. There are three ways of using the ocular micrometer, or of arriving at the size of the objects measured with it:

(1) By finding the value of a division of the ocular micrometer for each optical combination and tube-length used, and employing this valuation as a multiplier. This is the method given in the text, and the one most frequently employed. Thus, suppose with a given optical combination and tube-length it required five divisions on the ocular micrometer to include the image of 0.2 millimeter of the stage micrometer, then obviously one space on the ocular micrometer would include $\frac{1}{5}$ or 0.2 or 0.04 mm.; the size of any unknown object under the microscope would be obtained by multiplying the number of the divisions on the ocular micrometer required to include its image by the value of one space, or in this case 0.04 mm. Suppose some object, as the fly's wing, required 15 spaces of the ocular micrometer to include some part of it, then the actual size of this part of the wing would be $15 \times 0.04 = 0.6$ mm.

(2) By finding the number of divisions on the ocular micrometer required to include the image of an entire millimeter of the stage micrometer, and using this number as a divisor. This number is also sometimes called the ocular micrometer ratio. Taking the same case as in (1), suppose five divisions of the ocular micrometer are required to include the image of 0.2 mm., on the stage micrometer, then evidently it would require $5 \div 0.2 = 25$ divisions on the ocular micrometer to include a whole millimeter on the stage micrometer, and the number of divisions of the ocular micrometer required to measure an object divided by 25 would give the actual size of the object in millimeters or in a fraction of a millimeter. Thus, suppose it required 15 divisions of the ocular micrometer to include the image of some part of the fly's wing, the actual size of the part included would be $15 \div 25 = \frac{3}{5}$ or 0.6 mm. This method is really exactly like the one in (1), for dividing by 25 is the same as multiplying by $\frac{1}{25}$ or 0.04.

(3) By having the ocular micrometer ruled in millimeters and divisions of a millimeter, and then getting the size of the real image in millimeters. In employing this method a stage micrometer is used as object and the size of the image of one or more divisions is measured by the ocular micrometer, thus: Suppose the stage micrometer is ruled 0.1 and 0.01 mm. and the ocular micrometer is ruled in millimeters and 0.1 mm. Taking 0.2 mm. on the stage micrometer as object, as in the other cases, suppose it requires 10 of the 0.1 mm. spaces or 1 mm. to measure the real image, then the real image must be magnified $1.0 \div 0.2 = 5$ diameters, that is, the real image is five times as great in length as the object, and the size of an object may be determined by putting it under the microscope and getting the size of the real image in millimeters

with the ocular micrometer and dividing it by the magnification of the real image, which in this case is 5 diameters.

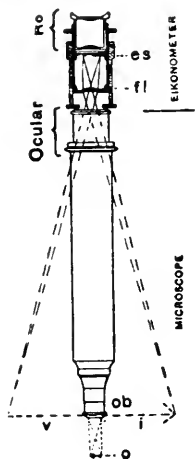

FIG. 96. WRIGHT'S EIKONOMETER.

(From Sir A. E. Wright's Principles of Microscopy).

o Object.

vi Virtual image.

ob Objective.

Microscope Ocular, the objective, tube and ocular of the microscope.

Eikonometer The Ramsden ocular (*Ro*) magnifying 10 diameters, and field lens (*fl*) above the ocular of the microscope.

es The real image formed at the diaphragm of the eikonometer.

Use the fly's wing as object, as in the other cases, and measure the image of the same part. Suppose that it required 30 of the 0.1 mm. divisions = 3 mm. to include the image of the part measured, then evidently the actual size of the part measured is 3 mm. \div 5 = $\frac{3}{5}$ mm., or 0.6 mm., the same result as in the other cases. See also § 253 on the eikonometer.

In comparing these methods it will be seen that in the first two (1 and 2) the ocular micrometer may be simply ruled with equidistant lines without regard to the absolute size in millimeters or inches of the spaces. In the last method the ocular micrometer must have its spaces some known division of a millimeter or inch. In the first two methods only one standard of measure is required, viz., the stage micrometer; in the last method two standards must be used, viz., a stage micrometer and an ocular micrometer.

§ 253. Eikonometer for magnification and micrometry.

— The eikonometer is something like an eye. It has a converging lens serving in place of the crystalline lens to focus the rays from the eye-piece of the compound microscope, or from the simple microscope upon a micrometer scale, the scale taking the place of the retina in the eye (fig. 77-78). This scale is ruled in 0.1 mm. Above the scale is a Ramsden ocular of 25 mm. equivalent focus, giving a magnification of 10. The eikonometer scale therefore is a millimeter scale when seen at the distance of 250 mm. in the visual field of the normal human eye, and it enables one to put a millimeter scale on the image of any object studied.

To use it for magnification a stage micrometer is put under the microscope and carefully focused. Then the eikonometer is put in place over the ocular. The microscopic image of the stage micrometer and the scale of the eikonometer will then appear in the same field as with the ordinary ocular micrometer (§ 240). The two sets of lines should be made parallel

(§ 239-241). See how many divisions of the eikonometer millimeter scale are required to measure one or more of the divisions of the image of the stage micrometer. Suppose it requires 6 intervals or millimeters of the eikonometer scale to measure the image of 0.03 mm. on the stage micrometer. The size of the object is then 0.03 mm. and of its image 6 mm. The magnification is therefore (§ 228) $6 \div 0.03 = 200$.

For determining the magnification of a simple microscope the eikonometer is placed over the simple microscope as it was over the ocular above. With this instrument, as with the camera lucida, only one eye is used (fig. 81, 100).

§ 254. Micrometry with the eikonometer. — In the first place the magnification of the microscope must be determined as described in the preceding section; and one must keep in mind the factors which will vary the magnification (§ 235). The object to be measured is put under the microscope and focused and the eikonometer put in position. The virtual image is then measured in millimeters by the scale of the instrument. The size of this virtual image is then divided by the magnification and the result will be the actual size of the object as in § 248.

For example suppose the long axis of a Necturus' red blood corpuscle measures 9 mm. on the eikonometer scale. If the magnification of the microscope is 200, as found above, then the actual length of the corpuscle is $9 \text{ mm.} \div 200 = 0.045 \text{ mm.}$, or 45μ .

§ 255. Micrometry by the aid of the condenser image of a scale. — Probably every one is all too familiar with the cross bars of the window in the field of the microscope. This is, as well known, a real image of the window produced by the condenser at the level of the object. The possibility of projecting a real image at the level of the object is taken advantage of for purposes of micrometry as follows: A lantern slide is made of net lines (fig. 97) or of any parallel, equidistant lines. The lantern slide is then set up exactly 10 cm. or some other exact distance in front of the microscope. A good light from the window or from one of the daylight lanterns (fig. 37-38) must traverse the lantern slide. This light is reflected up through the condenser by the plane mirror. The condenser will form a real image of the network or parallel lines at about the level where the object is placed on the slide.

If now one focuses a 16 mm. or other objective upon this real image, it will appear very clearly in the field of the microscope. In order to utilize the image for micrometry the valuation of the spaces must be determined by the use of a stage micrometer as with the ocular micrometer (§ 240). Place a stage micrometer under the microscope and focus the lines sharply. Then with the screw or rack of the substage condenser focus the condenser up and down until the image of the

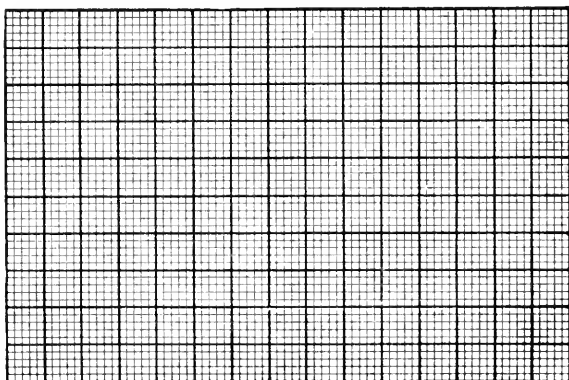

FIG. 97. NET SCALE FOR USE IN MICROMETRY WITH THE CONDENSER IMAGE.

lines or net on the lantern slide are also sharp. Arrange the stage micrometer so that the lines are parallel with the lines of the condenser image. Make any two of the lines coincide. Count the number of spaces in the condenser image included between any two of the lines of the stage micrometer, and divide the value of the space in the stage micrometer by the number of spaces of the condenser image included, and the quotient will represent the valuation of the spaces of the condenser image in millimeters. For example, suppose the stage micrometer is ruled in 0.1 mm. and that 12 spaces of the condenser image are included in 9 spaces of the stage micrometer; then each space of the condenser image has a valuation of $0.9 \text{ mm.} \div 12 = 0.075 \text{ mm.}$

As the size of the image varies with the distance of the object from

the center of the condenser (§ 229), if the object (lantern slide of the lines) is always placed exactly the same distance in front of the microscope the real image formed by the condenser will be of the same size, and hence have the same valuation for micrometry regardless of the power of the objective or the length of tube used. It is a very convenient method of micrometry for all coarser objects, but not exact enough for the finer objects. A movable scale or filar ocular micrometer should be used for the most exact work.

Example of an actual measurement by means of the condenser image: The long axis of a red corpuscle of *Necturus* measured 0.61 of a space of the condenser image. As each space represents 0.075 mm. the length of the corpuscle is: $0.061 \times 0.075 = 0.04575$ mm. or 45.75μ (see Chamot, pp. 155-157).

§ 256. **Remarks on micrometry.** — In using adjustable objectives (§ 31, 134) the magnification of the objective varies with the position of the adjusting collar, being greater when the adjustment is closed, as for thick cover-glasses, than when open, as for thin ones. This variation in the magnification of the objective produces a corresponding change in the magnification of the entire microscope and the ocular micrometer valuation; therefore it is necessary to determine the magnification and ocular micrometer valuation for each position of the adjusting collar.

While the principles of micrometry are simple, it is very difficult to get the exact size of microscopic objects. This is due to the lack of perfection and uniformity of micrometers and the difficulty of determining the exact limits of the object to be measured. Hence, all microscopic measurements are only approximately correct, the error lessening with the increasing perfection of the apparatus and the skill of the observer.

A difficulty when one is using high powers is the width of the lines of the micrometer. If the micrometer is perfectly accurate half the width of each line belongs to the contiguous spaces, hence one should measure the image of the space from the centers of the lines bordering the space, or, as this is somewhat difficult in using the ocular micrometer, one may measure from the inside of one bordering line and from the outside of the other, that is, from the right side of all the

lines, or from the left side of all. If the lines are of equal width this is as accurate as measuring from the center of the lines. Evidently it would not be right to measure from either the inside or the outside of both lines (fig. 90, 98).

It is also necessary in micrometry to use an objective of sufficient power to enable one to see all the details of an object with great distinctness. The necessity of using sufficient amplification in micrometry has been especially remarked upon by Richardson, *Monthly Micr. Jour.*, 1874, 1875; Rogers, *Proc. Amer. Soc. Microscopists*, 1882, p. 239; Ewell, *North Amer. Pract.*, 1890, pp. 97, 173.

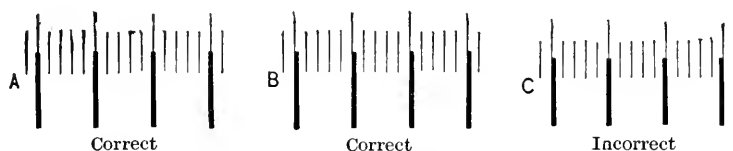

FIG. 98. CORRECT AND INCORRECT ARRANGEMENT OF THE OCULAR AND OF THE STAGE MICROMETER LINES.

(From Chamot).

The fine lines are those of the ocular micrometer and the coarse ones of the stage micrometer (compare fig. 90).

As to the limit of accuracy in micrometry, one who has justly earned the right to speak with authority expresses himself as follows: "I assume that 0.2μ is the limit of precision in microscopic measures beyond which it is impossible to go with certainty." W. A. Rogers, *Proc. Amer. Soc. Micrs.*, 1883, p. 198.

In comparing the methods of micrometry with the compound microscope given above (§ 247-253), the one given in § 247 is impracticable, that given in § 252-3 is open to the objection that two standards are required, — the stage micrometer and the steel rule; it is open to the further objection that several different operations are necessary, each operation adding to the probability of error. Theoretically the method given in § 249 is good, but it is open to the very serious objection in practice that it requires so many operations which are especially liable to introduce errors. The method that experience has found most safe and expeditious, and applicable to all objects,

is the method with the ocular micrometer. If the valuation of the ocular micrometer has been accurately determined, then the only difficulty is in deciding on the exact limits of the objects to be measured and so arranging the ocular micrometer that these limits are enclosed by some divisions of the micrometer. Where the object is not exactly included by whole spaces on the ocular micrometer, the chance of error comes in, in estimating just how far into a space the object reaches on the side not in contact with one of the micrometer lines. If the ocular micrometer has some quite narrow spaces, and others considerably larger, one can nearly always manage to exactly include the object by some two lines. The ocular screw micrometers (fig. 91, 94) obviate this entirely, as the cross hair or lines traverse the object or its real image, and whether this distance be great or small it can be read off on the graduated wheel, and no estimation or guess work is necessary.

The new method by means of Wright's eikonometer (§ 253-254) is spoken of very favorably by experts who have employed it.

COLLATERAL READING FOR CHAPTER V

Sir A. E. Wright's Principles of Microscopy. Chamot, Chemical Microscopy.

For those especially interested in micrometry in its relation to medical jurisprudence the following are recommended. They treat the subject in a practical as well as in a scientific spirit. The papers of Prof. Wm. A. Rogers on micrometers and micrometry, in the *Amer. Quar. Micr. Jour.*, Vol. I, pp. 97, 208; *Proceedings Amer. Soc. Microscopists*, 1882, 1883, 1887. Dr. M. D. Ewell, *Proc. Amer. Soc. Mics.*, 1890; *The Microscope*, 1889, pp. 43-45; *North Amer. Pract.* 1890, pp. 97, 173. Dr. J. J. Woodward, *Amer. Jour. of the Med. Sci.*, 1875. M. C. White, Article "Blood Stains," *Ref. Hand-Book Med. Sciences*, 1885. *Medico-Legal Journal*, Vol. XII. For the change in magnification due to a change in the adjustment of adjustable objectives, see *Jour. Roy. Micr. Soc.* 1880, p. 702; *Amer. Monthly Micr. Jour.*, 1880, p. 67. Carpenter-Dallinger, p. 270 and end of § 196.

If one consults the medico-legal Journals; the microscopical journals, the *Index Medicus*, and the *Index Catalog* of the library of the Surgeon General's Office, under *Micrometry*, *Blood*, and *Jurisprudence*, he can get on track of the main work which has been and is being done.

CHAPTER VI

DRAWING WITH THE MICROSCOPE AND WITH PROJECTION APPARATUS; CLASS DEMONSTRATIONS

§ 265. Apparatus and material for Chapter VI.

1. Microscope.
2. Abbe and Wollaston's camera lucidas (fig. 99-100).
3. Drawing board (fig. 101, 102, 109).
4. Thumb tacks and small tacks (§ 275).
5. Pencils (§ 275).
6. Microscope screen (fig. 33).
7. Microscopic preparations.
8. Small arc lamp with condenser (fig. 49).
9. Large projection apparatus (fig. 109-112).
10. 45° mirror or prism (fig. 109-114).
11. Mazda stereopticon lamp of 250 or 400 watts (§ 289, 362).
12. Micrometer, one-half millimeter, and one in one-tenth and one-hundredth millimeters (fig. 80).
13. Mounted letters.
14. Printed letters to put on drawings (§ 302).
15. Carbon drawing pencils (§ 290).
16. Graphite drawing pencils (§ 288-290).
17. Water-proof India ink (Higin's or Weber's) (§ 288-290).
18. Crow quill pens (§ 288).
19. Right line pen and other drawing instruments (§ 288).
20. Erasers.
21. Tracing paper (§ 286).
22. Whatman's hot-pressed drawing paper (§ 291).
23. Reynold's bristol-board (§ 291).
24. Developing photographic paper (§ 289-290).
25. Camera obscura or photographic camera and material for negatives (fig. 107, § 285-289).
26. Ruby glass (§ 288-291).
27. Gihon's opaque and fine brush (§ 291).
28. Metric scale (fig. 104).
29. T-square and triangles (§ 303).
30. Air-brush (§ 291).
31. Simple microscopes (§ 306).
32. Demonstration compound microscopes (§ 307).
33. Traveling microscope (§ 308).
34. Indicator ocular (§ 309).
35. Markers for ringing (§ 310).
36. Projection microscope (§ 311).
37. Masking paper (§ 312a).
38. Objectives, amplifiers, oculars (§ 313).
39. Prism or 45° mirror (§ 315).
40. Hay infusion (§ 211, 315).
41. Four-window daylight lantern (§ 316).
42. Demonstration table for 8 microscopes (§ 316).

DRAWING

§ 266. **Methods of drawing.** — There are five principal methods for obtaining drawings in general, and all the methods are applicable to the production of drawings of microscopic objects:

(1) Freehand drawings. This is the simplest method if one has natural ability and adequate training, for one only needs an object, pencil, pen and paper.

(2) Camera lucida drawings. By this method the outlines and proportions can be accurately traced (§ 268-275).

(3) Camera obscura drawings. By this method the real image obtained in a photographic camera can be traced (§ 285).

(4) Projection drawings. In this method real images like those of the magic lantern and projection microscope can be traced directly upon the drawing paper (§ 292).

(5) Line drawings on blue prints and on the back of photographs (§ 288-289).

In many laboratories all the methods are used, sometimes separately, but more often combined.

§ 267. **Free-hand drawings.** — Microscopic objects may be drawn free-hand directly from the microscope, but in this way a picture giving only the general appearance and relations of parts is obtained. For pictures which shall have all the parts of the object in true proportions and relations, it is necessary to obtain an exact outline of the image of the object, and to locate in this outline all the principal details of structure. It is then possible to complete the picture free-hand from the appearance of the object under the microscope.

§ 268. **Camera lucida.** — This is an optical apparatus for enabling one to see objects in greatly different situations as if in one field of vision, and with the same eye. In other words, it is an optical device for superimposing or combining two fields of view in one eye.

As applied to the microscope, it causes the magnified virtual image of the object under the microscope to appear as if projected upon the table or drawing board, where it is visible with the drawing paper, pencil, dividers, etc., by the same eye, and in the same field of vision. The microscopic image appears like a picture on the drawing paper (see § 271a). This is accomplished in two distinct ways:

(1) By a camera lucida reflecting the rays from the microscope so that their direction when they reach the eye coincides with that of the rays from the drawing paper, pencil, etc. In some of the camera lucidas from this group (Wollaston's, fig. 99), the rays are

reflected twice, and the image appears as when looking directly into the microscope. In others the rays are reflected but once, and the image has the inversion produced by a plane mirror. For drawing purposes this inversion is a great objection, as it is necessary to

similarly invert all the details added free-hand.

(2) By a camera lucida reflecting the rays of light from the drawing paper, etc. so that their direction when they reach the eye coincides with the direction of the rays from the microscope (fig. 100). In all of the camera lucidas of this group, the rays from the paper are twice reflected and no inversion appears.

The better forms of camera lucidas (Wollaston's, Grunow's, Abbe's, etc.) may be used for drawing both with low and with high powers. Some require the microscope to be inclined (fig. 99) while others are designed to be used on the microscope in a vertical position. As in biological work, it is often necessary to have the microscope vertical,

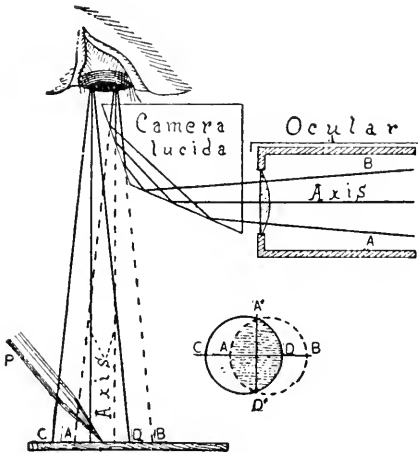

FIG. 99. WOLLASTON'S CAMERA LUCIDA.

Axis The optic axis of the microscope.

Ocular The upper end of the ocular.

A, B Two rays outside the axis to show that they cross twice and hence have the same relative position as when they emerge from the ocular.

Camera lucida The quadrangular piece of glass giving the double internal reflection to change the direction of the axial ray 90° .

CD, AB The virtual image, drawing paper and pencil partly overlapping. Where they overlap the appearance is that of one field.

the form for a vertical microscope is to be preferred (see fig. 100).

§ 269. **Avoidance of distortion.**—In order that the picture drawn by the aid of a camera lucida may not be distorted, it is necessary that the axial ray from the image on the drawing surface shall be at right angles to the drawing surface (fig. 99, 101).

§ 270. **Wollaston's camera lucida.**—This is a quadrangular prism of glass put in the path of the rays from the microscope, and

it serves to change the direction of the axial ray 90 degrees. In using it the microscope is made horizontal, and the rays from the microscope enter one-half of the pupil, while rays from the drawing surface enter the other half of the pupil. As seen in fig. 99, the fields partly overlap, and where they do so overlap, pencil or dividers and microscopic image can be seen together.

In drawing or using the dividers with the Wollaston camera lucida it is necessary to have the field of the microscope and the drawing surface about equally lighted. If the drawing surface is too brilliantly lighted the pencil or dividers may be seen very clearly, but the microscopic image will be obscure. On the other hand, if the field of the microscope has too much light the microscopic image will be very definite, but the pencil or dividers will not be clearly visible. It is necessary, as with the Abbe camera lucida (§ 271), to have the Wollaston prism properly arranged with reference to the axis of the microscope and the eye-point. If it is not, one will be unable to see the image well, and may be entirely unable to see the pencil and the image at the same time. Again, as rays from the microscope and from the drawing surface must enter independent parts of the pupil of the same eye, one must hold the eye so that the pupil is partly over the camera lucida and partly over the drawing surface. One can tell the proper position by trial. This is not a very satisfactory camera to draw with, but it is a very good form to measure the vertical distance of 250 mm. at which the drawing surface should be placed when determining magnification (fig. 85).

§ 271. **Abbe camera lucida.** — This consists of a cube of glass cut into two triangular prisms and silvered on the cut surface of the upper one. A small oval hole is then cut out of the center of the silvered surface and the two prisms are cemented together in the form of the original cube with a perforated 45 degree mirror within it (fig. 100-101). The upper surface of the cube is covered by a perforated metal plate. This cube is placed over the ocular in such a way that the light from the microscope passes through the hole in the silvered face and thence directly to the eye. Light from the drawing surface is reflected by the mirror to the silvered surface of the prism and reflected by this surface to the eye in company with

the rays from the microscope, so that the two fields appear as one, and the image is seen as if on the drawing surface (fig. 100-102, § 271a).

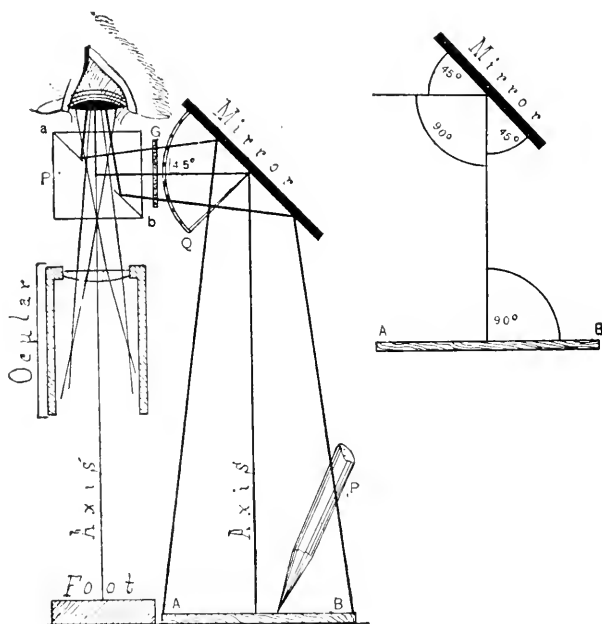

FIG. 100. DIAGRAM OF ABBE'S CAMERA LUCIDA WITH A VERTICAL MICROSCOPE.

Axis, Axis The axial ray of the microscope and from the field of the drawing surface.

Ocular The upper part of the microscope ocular.

Mirror The mirror of the camera lucida reflecting the rays from the drawing surface at right angles to the axis.

P, P The drawing pencil in the field, and the prism of the camera lucida.

Q The quadrant attached to the mirror to give the angle.

G Smoked glass.

a b The silvered surface in the prism with a hole made in the center for the light to pass upward from the microscope. The silvered part reflects the rays from the drawing surface.

The geometrical figure at the left gives the angles when a 45° mirror is used.

§ 271a. For some persons the image and the drawing surface, pencil, etc., do not appear on the drawing board as stated above, but under the microscope, according to the general principle that "objects appear in space where they could be touched along a perpendicular to the retinal surface stimulated," — that is, in

the line of rays entering the eye. This is always the case with the Wollaston camera lucida. The explanation of the apparent location of the image, etc., on the drawing board with the Abbe camera lucida is that the attention is concentrated upon the drawing surface rather than upon the object under the microscope. With some observers it is possible to make the image appear under the microscope or on the drawing surface at will by concentrating the attention on one position or the other. (Dr. W. B. Pillsbury).

§ 272. **Arrangement of the camera lucida prism.** — In placing this camera lucida over the ocular for drawing or the determination of magnification, the center of the hole in the silvered surface is placed in the optic axis of the microscope. This is done by properly arranging the centering screws that clamp the camera to the microscope tube or ocular. The prism must not only be centered to the axis of the microscope, but it must be at the right level or more or less of the field will be cut off. In all the good modern forms of this camera lucida it is fastened to the tube of the microscope by a clamp which enables one to raise or lower it so that it may be at the right position with reference to the eye-point of the ocular being used (§ 57).

One can determine when the camera is in a proper position by looking into the microscope through it. If the field of the microscope appears as a circle and of about the same size as without the camera lucida, then the prism is in a proper position. If one side of the field is dark, then the prism is to one side of the center; if the field is considerably smaller than when the prism is turned off the ocular, it indicates that it is not at the correct level, i.e., it is above or too far below the eye-point.

§ 273. **Arrangement of the mirror and the drawing surface.** — The Abbe camera lucida was designed for use with a vertical microscope (fig. 100). On a vertical microscope if the mirror is set at an angle of 45° , the axial ray is at right angles with the table top or drawing board which is horizontal, and a drawing made under these conditions is in true proportion and not distorted. The stage of most microscopes, however, extends out so far at the sides that with a 45° mirror the image appears in part on the stage of the microscope. In order to avoid this the mirror may be depressed to some point below 45° , say at 40° or 35° (fig. 101). But as the axial ray from

the mirror to the prism must still be reflected horizontally, it follows that the axial ray no longer forms an angle of 90° with the drawing

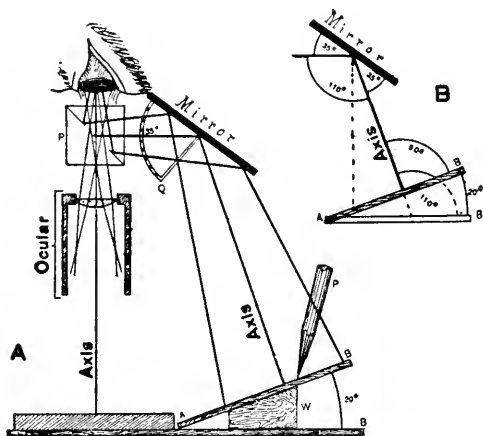

FIG. 101. DIAGRAM OF THE ABBE CAMERA LUCIDA WITH THE DRAWING SURFACE ELEVATED TO MAKE THE AXIS PERPENDICULAR WITH DEPRESSED MIRROR.

A, Axis, Axis The axial ray from the microscope and from the drawing surface.

Ocular The upper part of the microscopic ocular.

Mirror The mirror of the camera lucida; it is depressed from 45° to 35° to make the axis from the drawing surface perpendicular to the axis of the microscope.

A—B The drawing surface elevated 20° ; that is, twice as many as the mirror is depressed below 45° .

W Wedge under the drawing board.

P, P The drawing pencil and the prism of the camera lucida.

Q Quadrant of the mirror.

B Geometrical figure to show why the drawing board must be raised twice as many degrees as the mirror is depressed to keep the axial ray perpendicular to the drawing surface.

10° , and in the third case (35° mirror) the drawing board should be elevated 20° toward the microscope. Furthermore it is necessary in using an elevated drawing board to have the mirror bar of the

surface, but a greater angle. If the mirror is depressed to 35° , then the axial ray makes an angle of 110° with a horizontal drawing surface (fig. 101 B): To make the angle 90° again, so that there shall be no distortion, the drawing board must be raised toward the microscope 20° . The general rule is to raise the drawing board twice as many degrees toward the microscope as the mirror is depressed below 45° . Practically the field for drawing can always be made free of the stage of the microscope, at 45° , at 40° , or at 35° . In the first case (45° mirror) the drawing surface should be horizontal, in the second case (40° mirror) the drawing surface should be elevated

camera lucida project directly laterally so that the edges of the mirror are in planes parallel with the edges of the drawing board; otherwise there will be front to back distortion, although the elevation of the drawing board avoids right to left distortion. If one has a micrometer ruled in squares (net micrometer) (fig. 65, 97), the distortion produced by not having the axial ray at right angles with the drawing surface may be very strikingly shown. For example, set the mirror at 35° and use a horizontal drawing board. With a pencil make dots at the corners of some of the squares, and then with a straight edge connect the dots. The figures will be considerably longer from right to left than from front to back. Circles in the object appear as ellipses in the drawings, the major axis being from right to left.

The angle of the mirror may be determined with a protractor, but that is troublesome. It is much more satisfactory to have a quadrant attached to the mirror and an indicator on the projecting arm of the mirror. If the quadrant is graduated throughout its entire extent, or preferably at three points, 45° , 40° and 35° , one can set the mirror at a known angle in a moment; then the drawing board can be hinged and the elevation of 10° and 20° determined with a protractor. The drawing board is very conveniently held up by a broad wedge. By marking the position of the wedge for 10° and 20° the protractor need be used but once; then the wedge may be put into position at any time for the proper elevation.

§ 274. **Abbe camera and inclined microscope.** — It is very fatiguing to draw continuously with a vertical microscope, and many mounted objects admit of an inclination of the microscope, when one can sit and work in a more comfortable position. The Abbe camera is perfectly adapted to use with an inclined as with a vertical microscope. All that is requisite is to be sure that the fundamental law is observed regarding the axial ray of the image and the drawing surface, viz. that they should be at right angles. This is very easily accomplished as follows: The drawing board is raised toward the microscope twice as many degrees as the mirror is depressed below 45° (§ 273); then it is raised exactly as many degrees as the microscope is inclined, and in the same direction, that is, so that the end of the drawing board shall be in a plane parallel with the stage of

the microscope. The mirror must have its edges in planes parallel with the edges of the drawing board also (fig. 102).

§ 275. **Drawing with the Abbe camera lucida.** — (1) The light from the microscope and from the drawing surface should be of nearly equal intensity, so that the image and the drawing pencil can

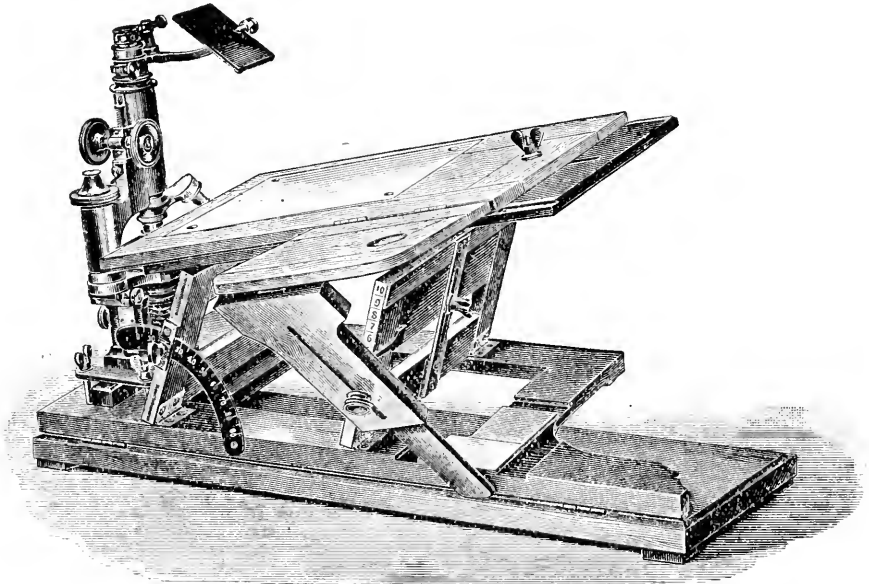

FIG. 102. BERNHARD'S DRAWING BOARD FOR THE ABBE CAMERA LUCIDA.

(From the Catalogue of Zeiss).

This drawing board can be elevated and tipped; it can also be inclined, carrying the microscope with it.

be seen with about equal distinctness. This may be accomplished with very low powers (16 mm. and lower objectives) by covering the mirror of the microscope with white paper when transparent objects are to be drawn. For high powers it is best to use a substage condenser. Often the light may be balanced by using a larger or smaller opening in the diaphragm. One can tell which field is excessively illuminated, for it is the one in which objects are most distinctly seen.

If it is the microscopic, then the image of the microscopic object is very distinct and the pencil is invisible or very indistinct. If the drawing surface is too brilliantly lighted the pencil can be seen clearly, but the microscopic image is obscure.

When opaque objects, that is, objects which must be lighted with reflected light (fig. 21, 34), like dark colored insects, etc., are to be drawn, the light must usually be concentrated upon the object in some way. The microscope may be placed in a very strong light and the drawing board shaded, or the light may be concentrated upon the object by means of a concave mirror, or a bull's eye condenser or the small arc lamp (fig. 49) may be used.

If the drawing surface is too brilliantly illuminated, it may be shaded by placing a book or a ground-glass screen between it and the window, also by putting one or more smoked glasses in the path of the rays from the mirror (fig. 100). If the light in the microscope is too intense, it may be lessened by using white paper over the mirror, or by a ground-glass screen between the microscope mirror and the source of light (Piersol, *American Monthly Microscopical Journal*, 1888, p. 103). It is also an excellent plan to blacken the end of the drawing pencil with carbon ink. Sometimes it is easier to draw on a black surface, using a white pencil or style. The carbon paper used in manifolding letters, etc., may be used, or ordinary black paper may be lightly rubbed on one side with a moderately soft lead pencil. Place the black paper over white paper and trace the outlines with a pointed style of ivory or bone. A corresponding dark line will appear on the white paper beneath (*Jour. Roy. Micr. Soc.*, 1883, p. 423).

(1) It is desirable to have the drawing paper fastened with thumb tacks, or in some other way. (2) The lines made while using the camera lucida should be very light, as they are liable to be irregular. (3) Only outlines are drawn and parts located with a camera lucida. Details are put in free-hand. (4) It is sometimes desirable to draw the outline of an object with a moderate power and add the details with a higher power. If this is done it should always be clearly stated. It is advisable to do this only with objects in which the same structure is many times duplicated, as a nerve or a muscle.

In such an object all the different structures can be shown, and by omitting some of the fibers the others may be made plainer without undesirable enlargement of the entire figure. (5) If a drawing of a given size is desired and it cannot be obtained by any combination of oculars, objectives, and lengths of the tube of the microscope, the distance between the camera lucida and the table may be increased or diminished until the image is of the desired size. This distance is easily changed by the use of a book or a block, but more conveniently if one has a drawing board with adjustable drawing surface like that shown in fig. 102. (6) It is of advantage to have the camera lucida hinged so that the prism may be turned off the ocular for a moment's glance at the preparation, and then returned in place without the necessity of loosening screws and readjusting the camera. This form is now made by several opticians, and many of them add graduations so that the angle of the mirror is readily seen.

§ 276. **Scale of drawings.** — The scale should be given for every drawing (fig. 103). Sometimes the drawing is larger than the object, as with microscopic specimens, and sometimes it is of the same size or much smaller, as in drawing large objects.

In getting the scale at which an object is drawn with the microscope or projection microscope, the object is removed and a micrometer in half millimeters (fig. 65) for low powers and one in tenths and hundredths of a millimeter (fig. 80) for high powers is put in place of the specimen. The image of the micrometer lines and spaces will be of the same enlargement as the drawing, provided nothing has been changed except the micrometer for the object. If now a few of the lines of the micrometer image (fig. 80, 103) are traced at one corner of the drawing paper and their actual value given, the enlargement can be determined accurately as follows: Suppose the micrometer spaces are tenth millimeters, and the image of the spaces measures 2 millimeters, the enlargement must be the size of the image divided by the size of the object or $2 \div 0.1 = 20$, that is, the image is 20 times the size of the object.

In using the photographic camera for negatives or for tracing, if the metric scale (fig. 104) is put with the object its image will

appear with the image in the negative or in the tracing and the enlargement or reduction can be found as above. Suppose the image of the 10 cm. scale on the negative or in the tracing is 2 cm. long, obviously the picture must be $2 \text{ cm.} \div 10 = \frac{2}{10}$ or $\frac{1}{5}$, that is, the picture is only one-fifth the size of the object.

For any form of projection apparatus (fig. 109-114), the magic lantern or projection microscope, after the image is traced, the object is removed and a micrometer in half millimeters for the magic lantern and low powers of the microscope is put in place of the object and the image of the scale projected upon the drawing paper. Suppose the image of one of the micrometer half millimeter spaces measures 15 millimeters, then the scale of the drawing must be 30 (i.e., $15 \div \frac{1}{2} = 30$).

If one is drawing from the projected image of a negative or lantern slide it is necessary to know the scale at which the negative or slide was made as well as the scale at which the drawing from the projected negative or slide is being made. For example, if the scale of the negative is 50 times the size of the object, and the drawing is 10 times the size of the negative, the final drawing must be $10 \times 50 = 500$ times the size of the original object.

If on the other hand the negative is $\frac{1}{10}$ the size of the original object and the drawing is 5 times the size of the negative, the final drawing will be the size of the negative ($\frac{1}{10}$ the original) multiplied by the magnification (in this case 5) which is $\frac{1}{10} \times 5 = \frac{5}{10}$ or $\frac{1}{2}$. That is, the drawing is one-half the size of the original object.

For the projection microscope with powers from 40 to 16 mm. a micrometer in $\frac{1}{2}$ mm. is good. For powers above 16 mm. it is better to use a micrometer in 0.1 mm. and 0.01 mm. (fig. 80).

After the drawing has been made, remove the specimen and put the micrometer under the microscope and draw a few spaces of the micrometer image (fig. 103) giving the actual value of the spaces; then one can compute the enlargement of the drawing by measuring the image spaces and dividing by the actual value. For example, suppose the image of one of the 0.1 mm. spaces measures on the

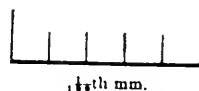

FIG. 103. MAGNIFIED MICROMETER SPACES TO SHOW THE METHOD OF INDICATING THE SCALE AT WHICH A DRAWING WAS MADE.

drawing 4 cm. or 40 mm., the scale of the drawing or its magnification is $40 \div 0.1 = 400$.

§ 276a. For diagrams and other large objects a very serviceable micrometer can be made by using the 10 cm. metric rule (fig. 104) as object and making a negative of it on a lantern slide exactly natural size or half natural size.



10 CENTIMETER RULE.

The upper edge is in millimeters, the lower in centimeters.

THE METRIC SYSTEM.

UNITS.

The most commonly used divisions and multiples.

THE METER FOR LENGTH	}	<i>Centimeter</i> (cm), 0.01 Meter; <i>Millimeter</i> (mm.), 0.001 Meter; <i>Micron</i> (μ), 0.001
		Millimeter; the Micron is the unit in Micrometry,
THE GRAM FOR WEIGHT	}	<i>Kilometer</i> , 1000 Meters; used in measuring roads and other long distances.
		<i>Milligram</i> (mg.), 0.001 Gram.
THE LITER FOR CAPACITY.	}	<i>Kilogram</i> , 1000 Grams, used for ordinary masses, like groceries, etc.
		<i>Cubic Centimeter</i> , (cc.), 0.001 Liter. This is more common than the correct form, Milliliter.

Divisions of the Units are indicated by the Latin prefixes; *deci*, 0.1; *centi*, 0.01; *milli*, 0.001; *micro*, one millionth (0.000001) of any unit.

Multiples are designated by the Greek prefixes; *deka*, 10 times; *hecto*, 100 times; *kilo*, 1000 times; *myria*, 10,000 times; *mega*, one million (1,000,000) times any unit.

FIG. 104. METRIC SCALE AND SUMMARY OF THE METRIC SYSTEM.

AVOIDANCE OF INVERSION

§ 277. It is desirable to make drawings like the object without any inversion whatsoever, provided the object has rights and lefts, etc. For structural detail like cells, etc., it makes no difference whether the image is erect or not, but with symmetrical organs and animals it is very confusing to have the parts inverted in the drawing. For example, it is unsatisfactory to have the liver shown as if on the left side and the heart on the right side.

In order to avoid inversions, it is necessary to know what inversions are produced by the different optical appliances used to assist in drawing. Then one can so arrange the object that the image

will be exactly like the object. It is believed that the following directions will enable the worker to so arrange his specimen and the apparatus that erect images may be produced without undue effort.

The simplest of all ways to get the image without inversion is to arrange the slide on a piece of white paper so that the object is erect and then to write with a very fine pen the letters a, k, on the cover-glass of the specimen to be drawn (fig. 105). Now with the low

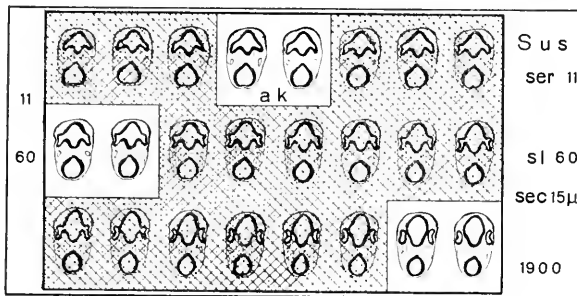

FIG. 105. SLIDE OF SERIAL SECTIONS, SHOWING THE DEVELOPMENT OF THE EYE WITH THE LETTERS a k, TO AID IN GETTING ERECT IMAGES IN DRAWING WITH PROJECTION APPARATUS.

(From Optic Projection).

This slide is also to show how to mask preparations which are to be used in class demonstration (Fig. 121).

power (16 to 60 mm.) objective project the image of the specimen and letters upon the drawing paper. One can then continue to rearrange the slide until the letters are erect; the specimen will then also be erect.

§ 278. **Images to be traced in the photographic camera.** — These images are wrong side up and the rights and lefts are reversed. This can be corrected by drawing the picture on the tracing paper in the inverted position and then inverting the tracing after it is finished; or the specimen can be put in the inverted position, then the image will be erect.

Demonstrate this by putting the metric card in position and tracing some of the larger letters or figures on the tracing paper. Then

turn the drawing paper around 180° and the letters or figures will appear erect.

Put the metric card wrong edge up to start with; then the letters or figures will appear right side up on the tracing paper.

§ 279. **The use of a negative for projection and tracing.** — Put the face of the negative that reads correctly next the source of light and wrong edge up: then it will appear erect in every way on the drawing paper. This is the way lantern slides are put in the holder.

§ 280. **The Wollaston or Abbe camera lucida.** — With these camera lucidas there are two reflections of the rays (fig. 99–100), consequently there is no inversion produced by the camera, but the microscope inverts the image the same as the photographic objective, and erect images are obtained either by inverting the drawing after it is made or by putting the object in an inverted position under the microscope, just as with the photographic camera.

Demonstrate that this will produce erect drawings by using the letters (fig. 105) and making sketches of their images by the camera lucida, having the letters right edge up on the stage in one case and wrong edge up in one.

ERECT IMAGES WITH THE PROJECTION MICROSCOPE

§ 281. **Erect images with an objective only or with an objective and amplifier.** — There are two cases: (1) When opaque drawing paper is used. In this case the object must be put on the stage with the cover-glass toward the light and the slide toward the objective, and it must be wrong edge up. Only low powers (16 mm. and lower objectives) should be used, for the thick slide introduces aberrations (fig. 51) and is liable to be too thick for the free working distance (fig. 31).

(2) When a translucent drawing paper is used and the drawing is made on the back. In this case the specimen is put on the stage wrong edge up, but with the cover-glass facing the objective. All powers can be used. This is similar to the conditions described for the photographic camera where the tracing paper is used on the clear glass (§ 278).

Test the correctness of the directions by using a preparation with the letters a, k, on the cover-glass (§ 277, fig. 105).

§ 282. Erect images with an objective or an objective and an amplifier and a prism or 45° mirror. — Place the specimen on the
10 CENTIMETER RULE

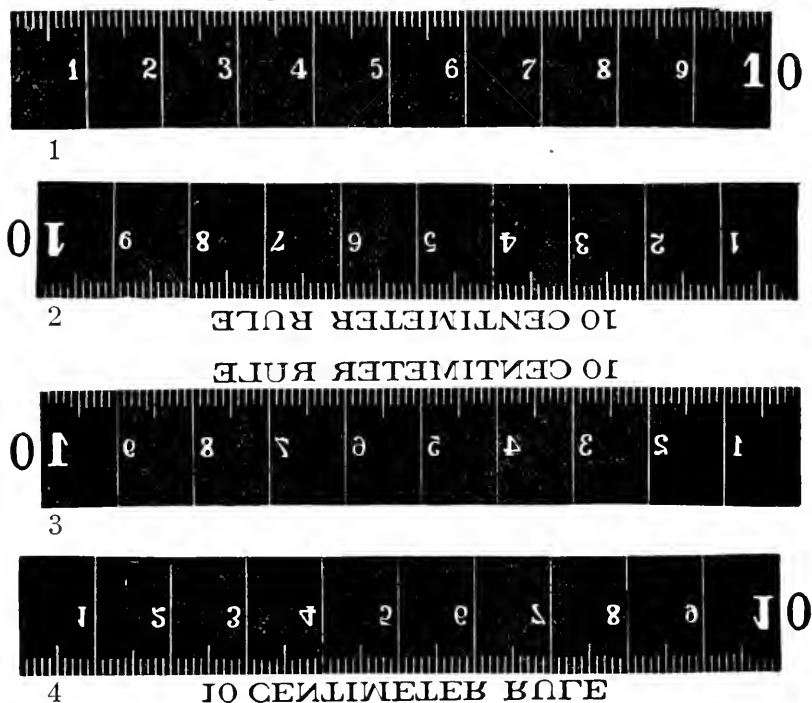

FIG. 106. 1, 2, 3, 4, ERECT AND INVERTED IMAGES OF THE METRIC SCALE.
 (From Optic Projection).

1. Erect image. 2. Inverted image. 3. Mirror image. 4. Inverted mirror image.

stage wrong edge up and with the cover-glass toward the objective. The image will be erect on the opaque drawing paper. Test with the lettered specimen (fig. 105).

§ 283. Erect images with an objective and an ocular. —

(1) Opaque drawing paper. Place the specimen on the stage

right edge up, but with the cover-glass facing the light, the slide toward the objective.

(2) Translucent drawing paper. If the drawing can be made on the back of translucent paper the specimen is placed on the stage right edge up and with the cover-glass facing the objective. Test with the lettered specimen (fig. 105).

§ 284. **Erect images with an objective and ocular and a 45° mirror or prism.** — Place the slide on the stage right edge up, and with the cover-glass facing the objective. The image will be erect on an opaque drawing surface. Test with the lettered preparation (fig. 105).

DRAWINGS BY THE AID OF THE PHOTOGRAPHIC CAMERA AND THE MAGIC LANTERN

§ 285. **Drawings by the aid of a photographic camera.** — The photographic camera (camera obscura) gives help for getting pictures of objects in three ways:

- (1) By producing real images which can be traced (§ 286).
- (2) By producing negatives which can be projected upon the drawing paper and traced, or the drawing can be done directly on the print, and all but the drawing removed from the print; or the drawing can be made on the back of the print (§ 288-289).
- (3) By producing large prints for retouching (§ 290).

§ 286. **Real images by the camera.** — For drawing with a photographic camera it is a great help to have a frame with a piece of clear glass to use instead of the ordinary ground-glass focusing screen. The tracing paper is stretched over the glass. The object is arranged as desired and placed in a strong light. The camera is then arranged to give the desired view, and the bellows pulled out and the whole camera moved toward or away from the object until the desired size is obtained. This tracing is transferred to the drawing paper in the usual manner and inked in. A camera like that shown in fig. 107 answers well; also a copying camera (fig. 108).

While inking in, and indeed whenever free-hand and optical methods of getting drawings are combined the object should be available for constant observation so that accuracy may be obtained.

§ 287. **Negatives by the camera.** — The object is arranged as desired and placed in a good light. A photographic camera is then

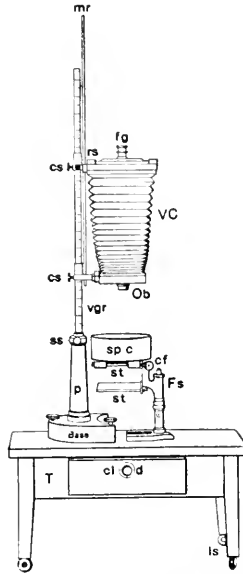

FIG. 107. VERTICAL PHOTOGRAPHIC CAMERA ON A LOW TABLE.

T Table about 50 cm. high and 50 cm. by 70 cm. on the top.

cl d Drawer with combination lock.

Base The heavy base of the vertical camera support.

p Pillar in which the graduated rod (*vgr*) rotates.

ss Set screw to fix the graduated rod in any position.

c s, c s Set screws to enable the operator to set the camera bellows at any desired extension.

mr Magnification rod with its set screw *rs*. When any desired magnification is arranged, the rod set screw is tightened; then by loosening the camera set screws (*cs*) the bellows can be moved up and down on the graduated rod to get the focus.

Fs Focusing stand; this is a microscope stand with coarse and fine adjustment (*cf*) and two stages (*st, st*) for supporting the object or the dish containing it (*sp c*).

Ob Photographic objective in the lower end of the camera.

VC Vertical camera bellows.

fg Focusing glass.

used and a negative on glass made in the usual manner. If the negative is to be used for prints on which to trace and draw with

ink or pencil, the negative is made the size of the desired finished picture. On the other hand if the negative is to be used for projection, it should be of about the size of a lantern slide (§ 290).

§ 288. **Drawings upon blue prints.** — This is especially available for objects with definite outlines and clear details like the wing veins of insects (Comstock) or apparatus, furniture, etc.

A negative of the object is made of the desired size and a blue print made. Then with waterproof India ink all the lines are gone

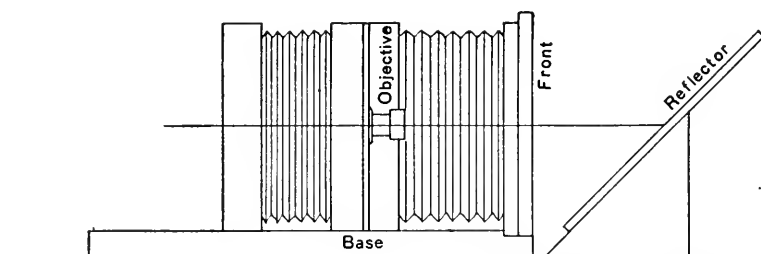

FIG. 108. CAMERA OBSCURA FOR DRAWING, AND LANTERN SLIDE MAKING.
(From Optic Projection).

over, and all the points indicated which are to be shown in the finished cut.

Bleach out the blue by soaking the print in a solution of 10% neutral oxalate of potash. Wash in water and dry on gauze. Only the ink lines will show in the finished print. This line drawing can then be lettered in any desired way, and the engraver can make a line cut for the printing press.

Ordinarily it is best to make the picture two or three times the size of the final engraving. Defects are minimized in the reduction. Always have the object in view in finishing the drawing.

§ 289. **Drawings on the back of photographic prints.** — Instead of making a blue print, a photographic print can be made of the negative of the object to be drawn in lines. Use double thick developing paper (Cyco, Velox, etc.).

For this the best method is to make a small negative of about the size of a lantern slide, using a rather long focus objective so that all

parts will be in focus and in proper perspective. Then with the projection apparatus using a photographic objective, print an enlarged

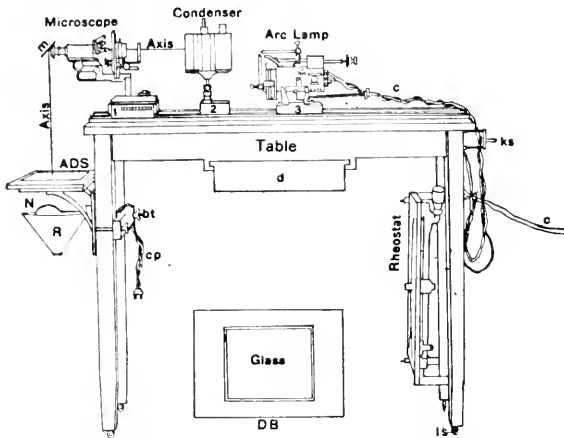

FIG. 109. PROJECTION MICROSCOPE, TABLE, AND ADJUSTABLE DRAWING SHELF. (Modified from Optic Projection).

DB Drawing board with a 25×30 cm. glass plate in the middle for tracing on the back of photographs. It is placed on the brackets to form the adjustable shelf (*ADS*).

ls Leveling screws in the bottom of the table legs.

Rheostat The balance for regulating the electric current of the arc lamp.

c c, ks Electric cable and knife switch.

Table The projection table with drawer (*d*). This table is 100 cm. high, and the top 125 cm. long and 50 cm. wide. It is stained by aniline black.

ADS Adjustable shelf with a drawing board having a glass center 25×30 cm.

bt Bolts with thumb nuts holding the shelf at any desired height on the legs.

N R Mazda lamp and reflector to throw the light up through the picture which is being traced.

c Cable with separable cap to attach to the lighting system.

Arc Lamp The right-angled carbon arc lamp for supplying light to the projection microscope.

Condenser The three lens condenser and water bath (fig. 110).

Microscope The compound microscope with substage condenser and ocular.

m 45° mirror or prism for reflecting the light directly downward upon the drawing shelf.

Axis, Axis The principal optic axis.

picture as follows: Work in a dark room or at night. Place the negative near the condenser as for lantern slide projection (fig. 110). Either the projection apparatus must be movable or a movable

screen must be used to get the desired size, which should be two, three, or four times the size of the final picture. Use a large printing frame, one 25×30 or 28×35 cm. (10×12 or 11×14 in.). Place the printing frame, in which are a clear glass and a white sheet of paper, against the wall or movable screen, and by moving the screen or the apparatus get the picture the desired size. Now focus very sharply. The diaphragm of the objective must be wide open. Turn off the light from the arc lamp and place in the printing frame a sheet of the photographic paper. Place a piece of ruby glass over the end of the projection objective, turn on the light, and then arrange the printing frame so that the picture is in the desired position. Remove the ruby glass and give an exposure of 2 to 5 seconds for the arc light or considerably more for a stereopticon mazda lamp. Replace the ruby glass over the objective, turn off the light, and develop the picture as usual. A good plan to follow is to put a small piece of paper in the printing frame and test the exposure before putting the large sheet in the frame. The paper is too expensive to use the large sheets for trial exposures.

When the prints are developed, fixed and dried, the drawing in lines is made as follows: Use a drawing board with a piece of plane glass in the middle (fig. 109) as the drawing shelf, and have under it an incandescent lamp and metal reflector (fig. 109). Fix the print face down on the drawing board and glass. The light from the lamp shines through the paper and one can see the picture almost as clearly as by looking at the face of the print. Now with the T-square, etc., put in the lines desired. For a beginner it is best to do this with pencil. Then the pencil sketch can be inked in at any time in the usual manner. While penciling in the lines the light should be turned off occasionally so that the pencil marks can be seen clearly; then one can see whether any essential parts have been omitted. The photographic paper is of excellent quality and takes the right line pen almost as well as the best drawing paper. The thick paper is used so that the photographic print will not show through, and because the thick paper holds its form better than the thinner paper. The thinner paper will also answer.

One can use this method with blue prints also. It has the ad-

vantage that the lines are perfectly distinct in every stage of the work. If drawn on the face of the print the blue obscures the pencil lines more or less while the drawing is being made.

For many objects it makes no great difference whether the picture is reversed or not, but in some cases there should be no reversal. One can easily make the picture so that the final picture will be erect as follows: Print the negative so that the photograph will be reversed; then when the line drawing is made on the back of the print the line drawing will be erect. Of course if the lines are made on the face of the print as with the blue print (§ 288) the print must be erect. To get erect prints turn the film side of the negative toward the sensitive paper as with contact printing. For reversed prints turn the glass side of the negative toward the paper.

This method of drawing is applicable for all sorts of objects, the photographic print serving to give all the outlines and proportions. No measurements need be made. Then by drawing the outlines on the back of the print, one can do all shading as if no picture were on the opposite side. It is of course not necessary for highly trained artists, but is of the greatest assistance for amateurs; and most biologists are amateurs.

In finishing the drawing, the object should be in view to make certain that the drawing is accurate.

§ 289a. Diaphragming the objective and the use of a concentrated filament lamp.— In the above directions a first-class photographic objective was assumed. If now one has not a first class objective or for any reason it is desirable to close the diaphragm more or less, the unobstructed cone of light cannot be used, but there must be a diffuser like ground-glass or milky glass put between the source of light and the negative to be projected. With such a diffuser one can close the diaphragm as desired. Of course the addition of the diffuser and the closing of the diaphragm will necessitate a longer exposure.

If instead of an arc lamp a concentrated filament stereopticon lamp is used one must also employ a diffuser or the shadows between the filaments of the lamp will give rise to inequalities in the print. The diffuser can be put between the condenser lenses or between the lamp and the condenser. It must be far enough from the negative so that the grain of the ground-glass will not show in the print (§ 362).

§ 290. Retouching photographs for halftone reproduction.— For pictures of animals, organs, and dissections to be reproduced by the halftone process, very successful drawings can be made as follows: Arrange the object as it is to appear in the finished drawing; light it

to bring out clearly the features desired; then use a long focus photographic objective and get a small, sharp picture. The negative should be about the size of a lantern slide, and it should be a good printing negative. Make a large print on thick developing paper exactly as described in the previous section (§ 289). This print should not be dark, but two or three shades lighter than the usual print to give opportunity for the added shading. The picture should be erect.

When the print is dry, put it on a drawing board and with a carbon drawing crayon, pen, India ink, and an air brush, if it is available, the picture can be made almost perfect with a minimum of labor.

In case the negative shows parts not needed or if the background is not as desired, the superfluous parts can be eliminated and the background made perfectly white by painting on the glass surface of the negative Gihon's or other opaquing medium. In the print there will be pure white where the opaque is painted on the glass. Use a fine brush and put on a layer which does not allow any light to pass. The opaque is put on the glass surface so that it can be easily removed if desired. In case some parts are not light enough or white points are to be added, use some of the white recommended by the photo-engravers (Blanc d'Argent etc.).

As in all drawing, the actual object should be before the artist when retouching the photograph, so that accuracy may be secured.

§ 291. Tracing pictures natural size on drawing paper.— It frequently happens in preparing the drawings for a book or for a scientific paper that figures from another book or from a scientific paper are needed. If there is to be no modification in the figure the simplest method is to borrow an electrotype. If this cannot be done and the picture is not available to put in the hands of the photo-engraver for a new cut, or if one wants to make minor changes, it is very easy to get a tracing on any good drawing paper as follows: Put the picture on the glass of the drawing shelf (fig. 109) and place over it some good drawing paper like Whatman's hot-pressed drawing paper or Reynolds bristol board. Turn on the light, and even through the thick drawing paper the outlines of the picture are so clear that the tracing can be made with ease. After the outlines have been

traced, the finishing can be done on a drawing board, having the original picture for reference.

§ 292. Drawings by a projection or a photographic objective. — For light use an arc lamp or a stereopticon mazda lamp; use a negative which is not too dense or a lantern slide. It is placed in the lantern-slide holder and by means of an ordinary projection objective, or better by a photographic objective, the image is projected upon the drawing paper (fig. 110). For the proper size either the

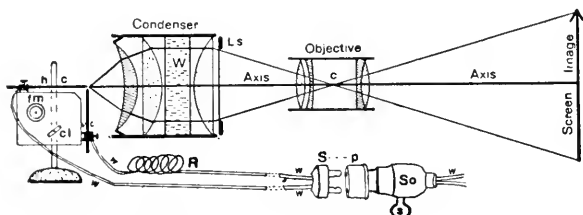

FIG. 110. MAGIC LANTERN WITH PROJECTED IMAGE.

(From Optic Projection).

A small arc lamp connected with the house lighting system is used for light in this case.

W, So, S — p Electric wires, lamp socket with key switch (*s*) and a separable attachment plug.

R Rheostat.

Condenser, W A three lens condenser with a water cell to absorb radiant heat.

LS Lantern slide.

Axis, Objective The principal optic axis of the condenser and of the objective in one line. The cone of light crosses within the objective at (*c*).

Screen Image The real image projected upon the screen.

projection apparatus or the drawing surface must be movable. For most artists it is better to make the drawing two or three times the size which it is to have after engraving. The reduction minimizes the little irregularities which are almost sure to be present.

When the size is correct, and the image sharply focused, one can trace directly on the drawing paper with a pencil all the lines and details which it is desired to represent. Then the drawing can be inked in at leisure, remembering always to have the object for constant reference and thus insure accuracy.

In making the negatives for projection it is very desirable that

the photographic objective should be of rather long focus and thus make it possible to have the camera at a considerable distance from the object; then there will be avoided the exaggerated perspective which comes from using a short focus objective.

All the different objects or parts of a large object at different levels will be in focus with the long focus objective at a considerable distance. In projection it is very easy to make the picture as large as desired provided the projection apparatus or the drawing surface is movable. The projection method has the advantage of being applicable to all forms of objects, gross and microscopic. The only precaution is to make the negative rather thin, not dense; then the details come out clearly in the projected image.

PROJECTION MICROSCOPE FOR DRAWING

§ 293. This is the most satisfactory method of drawing small objects. With it one can draw large diagrams or small figures directly from the objects; and if the apparatus is properly constructed one may make diagrams from objects 60 to 70 mm. in diameter down to those of half a millimeter or less. This method was much in vogue and highly commended by the older microscopists who used the solar microscope (Baker, Adams, and Goring). Since the general introduction of electric lighting, drawing with the projection microscope has become once more common and is the most satisfactory method known, especially for the numerous drawings necessary for the preparation of models in wax or blotting paper.

§ 294. **Drawings with low powers.** — For objectives of 30 to 100 mm. focus the best method is to use a projection outfit with a three lens condenser as shown in fig. 111. The whole should be on an optical bench so that each element and all together can be moved at will (fig. 131).

For a radiant a large or a small arc lamp is best (fig. 49, 111-112), but a 250 or 400 watt concentrated filament, stereopticon mazda lamp filled with nitrogen also works fairly well. It has the advantage that it can be attached to any lighting circuit, and when once centered and properly arranged requires no attention except to

turn the switch on and off. A dark room is desirable, but one can draw in any room at night.

Arrange the object, the lamp, and the condenser so that the object is fully lighted; then focus the objective and place the drawing surface and objective at a distance apart to give the desired size of drawing. Focus sharply and trace with a pencil the outlines and details which it is desired to show. Finally, with the object where it can be ex-

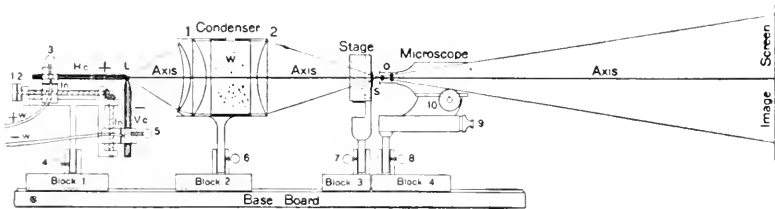

FIG. 111. PROJECTION MICROSCOPE.

(From Optic Projection).

+ w The positive wire going to the upper carbon (Hc), and - w , wire to the lower or vertical carbon (Vc) of the large arc lamp with direct current.

Axis, Axis, Axis The principal optic axis from the source of light (L) through the condenser, the microscope and to the screen.

W Water cell to absorb radiant heat.

Stage The separate stage of the microscope with its water cell for cooling the specimen by induction.

Microscope In this case the microscope has an objective only; compare fig. 100, where an ocular is present also.

Each element, lamp, condenser, stage, and microscope is on a separate movable block (block 1, 2, 3, 4) which slides independently along the optic bench or base board (fig. 131).

amined at any time, ink in the lines and details (for erect images see § 282).

§ 295. Use of a 45° mirror or a prism. — While one can draw on a vertical surface it is far easier to draw on a horizontal surface. This is available for all powers by using a plane mirror at 45° or a drawing prism. The mirror may be at a distance from the objective, when it must be large (fig. 112), or it may be close to the objective, when it may be small (fig. 109, 114). The drawing surface must be movable to vary the size of the drawing and the magnification. Figures 109, 111-112 show the two principal methods of

varying the distance between the objective and the drawing surface, and consequently the scale of the drawing (for erect images see § 277-284).

§ 296. **Drawing with objectives of 25 to 10 mm. focus.** — For this the best way is to use a three lens condenser, as shown in fig. 109, 111,

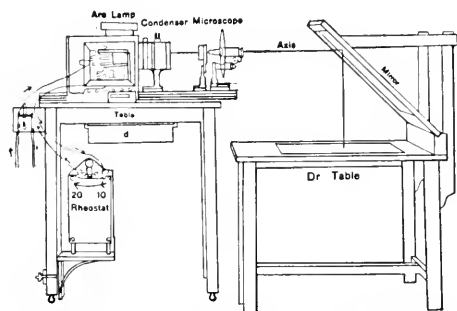

FIG. 112. PROJECTION MICROSCOPE WITH MOVABLE DRAWING TABLE AND 45° MIRROR.

(From Optic Projection).

The projection table has the dimensions given in fig. 109.

The arc lamp is automatic and the rheostat for current varying from 10 to 20 amperes.

The condenser is of the three lens water cell type, and the microscope with separate stage; the microscope has an amplifier in place.

The drawing table (Dr. Table) is of a convenient height for sitting beside. It is 76 cm. high and the top 100 cm. long and 75 cm. wide.

The 45° plate glass mirror is large (75 cm. long and 60 cm. wide).

After one has had sufficient practice, the drawing can be partly or wholly completed under the projection apparatus. For this one must light the drawing surface enough either by means of a portable lamp or by some means of letting in daylight. At the same time there must be a screen to cut off the image where one is doing the finishing. By removing the screen the image appears at any time and serves to check the work.

§ 297. **Drawing with high powers, 8 to 2 mm. focus.** — For this high power drawing one should use an ocular as well as an objective,

and for a microscope use either the special water-cell stage or the ordinary microscope with large tube. For radiant use a small or a large arc lamp. Remove the substage condenser or turn it aside and arrange on the optical bench so that the image of the light source from the large condenser falls directly on the specimen. Focus and arrange the drawing surface to give the right size and magnification, then trace the outlines and the details. Later, ink in, using the specimen to check up with (for erect images see § 277-284).

and a substage condenser in addition to the condenser of the lantern or small lamp (fig. 49, 114), or light of sufficient aperture will not be supplied to the microscope. In using the highest powers it is also well to connect the substage condenser to the slide by homogeneous liquid, as described in § 113. The large or small arc light is the only really satisfactory radiant (for erect images see § 283).

If one has a drawing room, a large or small arc lamp, and direct current, the arrangements shown in fig. 109 are best, but if direct current is not available, excellent results can be obtained by using the small arc lamp on the alternating current house electric lighting system and the microscope, as shown in fig. 113-114.

The light supplied to the substage condenser should be approximately parallel. This is attained with the small lamp by putting the arc at the focus of the condenser (fig. 49). With the large lamp

one should use a long focus lens for the condenser, as shown in fig. 115.

In all cases the substage condenser should be shifted up and down slightly until the best effect is produced. The substage condenser should of course be carefully centered before commencing to draw (§ 104).

§ 298. **Drawings for publication.** — The inexpensive photographic processes of making cuts for the printing press bring within the reach

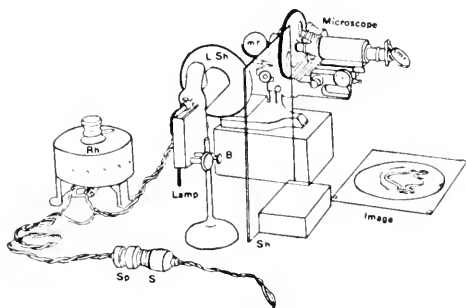

FIG. 113. DRAWING MICROSCOPE WITH SMALL ARC LAMP ON THE HOUSE LIGHTING SYSTEM.

(From Optic Projection).

S, Sp The lamp socket and separable attachment plug.

Rh The rheostat not allowing over 5 amperes of current to flow.

Lamp The small arc lamp (fig. 49), at right angles to the microscope.

Microscope The microscope on a block (*B*).

mr, mr The mirror of the microscope and the mirror over the ocular to reflect the light directly downward.

Image The picture of the microscopic object reflected down upon the drawing paper.

Sh Opaque shield to screen the light from the drawing surface.

of every writer the possibility of appealing to the eye by means of pictures and diagrams illustrating the facts which are presented in the text. Artistic ability is of course indispensable for a perfect representation, but any one willing to give the time and the pains

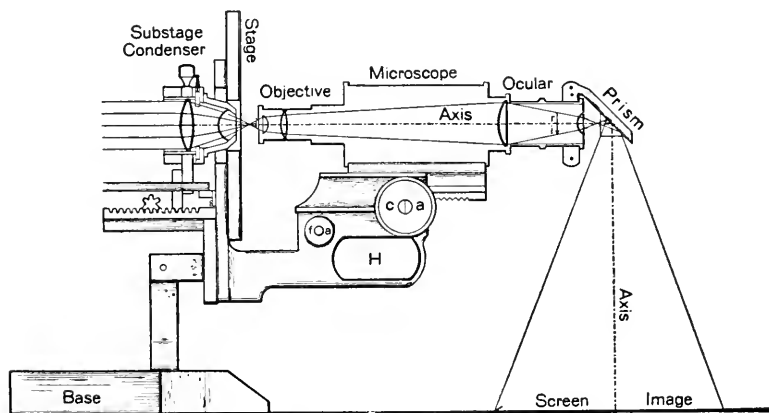

FIG. 114. THE MICROSCOPE ARRANGED FOR DRAWING ON A HORIZONTAL SURFACE.

(From Optic Projection).

The microscope is of the handle type (*H*) with the fine adjustment (*f a*) on the side below the coarse adjustment (*c a*).

The ocular is of the Huygenian form with the real image at (*r i*).

Prism, the right-angled prism beyond the ocular to reflect the light directly downward.

can make simple drawings, especially if one or more of the helps above described are available.

The various helps for making drawings described in this chapter will be found useful to the born artist as well as to the person who has not great artistic ability, for by means of the optical and mechanical helps the outlines and proportions can be secured with fidelity by any one. Then the born artist can use the time saved for making the pictures more artistic, and the plodder can feel confident that his efforts are correct even if not pretty.

Young authors are urged to get the Style Brief furnished by the Wistar Institute of Philadelphia. This is a guide for the preparation

of manuscript and drawings for publication in the scientific journals published by the Institute. The hints to contributors given on the second page of the cover in all the journals give in a nutshell the

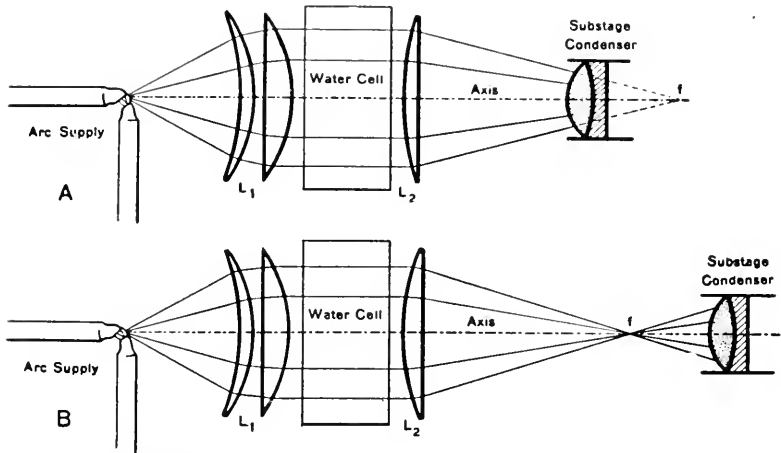

FIG. 115. DIAGRAMS TO SHOW THE POSITION OF THE SUBSTAGE CONDENSER WHEN NO PARALLELIZING LENS IS USED.

(From Optic Projection.)

A The substage condenser is within the focus (f) at a point where the long light cone is of about the same diameter as the substage condenser.

B The substage condenser is beyond the focus (f) of the long focus main condenser at a point where the diverging cone is of about the same diameter as the substage condenser. This is the better position for the substage condenser of the ordinary microscope.

Arc Supply The right-angled carbons of the arc lamp.

L₁ L₂ The first and the second elements of the main condenser.

Water Cell. This is to remove the radiant heat.

Axis The principal axis on which all the parts are centered.

f The principal focus of the second element of the main condenser. In both cases the focus is long.

Substage Condenser This is the first or lowest element of the substage condenser. It is of the achromatic type.

main points. These journals are: The American Journal of Anatomy; The Anatomical Record; The Journal of Morphology; The Journal of Comparative Neurology, and the Journal of Experimental Zoölogy.

A great many good hints can be found by studying the illustrations in well-printed books and in scientific journals, especially those dealing with the subject in which one is interested.

§ 299. **Outlining and inking in.** — In making drawings two steps are necessary for all but the most expert: (1) getting the outlines and main details in pencil, and (2) inking the outlines and details.

For the outlining one or more of the helps described above will be found almost indispensable. For the inking in the draughtsman should have the actual object for constant reference so that the representation may be accurate. The final work in inking is almost always done with a right line pen, free-hand, and of course in a good light and convenient position. If one would make colored pictures it is best to get the guidance and criticism of an expert.

One should keep in mind the way to make the picture erect when using any of the helps described (§ 277-284).

§ 300. **Size of drawings.** — For most draughtsmen it is wise to make the drawings two or three times the size of the final cut for publication. It is easier to make the details clear, and then little defects are minimized by the reduction. The photo-engraver can make the cut any desired reduction, but one should remember that the lines should be heavy enough for the reduction desired, otherwise the finest details are liable to be lost.

§ 301. **Reduction.** — There is some confusion as to the meaning of reduction in the minds of authors. For the engraver this term has a perfectly definite significance. It is linear measure, and never area or solid measure, that he considers. For example, if the engraver is directed to make the cut half the size of the drawing he will make every line half the length of the corresponding line in the drawing. The area will then be one-fourth that of the drawing. If the cut is to be reduced to one-fourth the drawing, each line will be only one-fourth the length of the original, and the area will be one-sixteenth that of the drawing (fig. 116).

§ 302. **Lettering drawings.** — After the drawings are finished the details must be indicated in some way. This may be by having the full name of the part, an easily intelligible abbreviation, or a letter or a numeral upon or near it (fig. 106).

The lettering should be done with discrimination in two ways:

(1) The letters, words, etc., should be artistically arranged and then put on straight. For this one may need to use a T-square and straight edge. Most persons cannot letter neatly enough to letter with a pen. Printed words and letters can be pasted upon the drawing. In the final cut the appearance is as if words, letters, or numerals were printed on the picture (fig. 25).

If the letters, abbreviations, etc., are not upon the parts they are meant to indicate, then "leaders," that is, full or broken lines should be drawn from the part to its designating letter, numeral, abbreviation, or word (fig. 20, 25).

(2) The size of type to be used should correspond to the size of the picture and the amount of reduction. The letters should not be the most prominent thing about a picture, neither should they be so small that one needs a microscope to read them. By consulting fig. 116 one can get a clear notion of the appearance of various sizes of letters when reduced. If one has a camera (fig. 107), it is a good plan to put letters of different sizes upon the drawing and then, having the bellows set to give the reduction desired, look at the image of the drawing and lettering and see how they will look in the final picture.

For photo-engraving, Gothic type gives the best results (fig. 116).

§ 303. **Fastening the letters to the drawing.** — The letters, etc., should be printed on thin, smooth, very white paper, and they should be black, not gray. Tissue paper is often used, but that is not so easy to handle as a paper about like the so-called "Bible paper."

The words, letters, and numerals for a drawing are cut out and arranged on the drawing to get the best effect. Then using a T-square and straight edge each letter or word is stuck to the drawing in the proper position as follows: Some fresh starch paste is made by placing in a small tin or aluminum dish 5 grams of laundry starch and adding 50 cc. of cold water. Stir with a spoon and then heat gradually with constant stirring on a stove or over a gas flame until the paste is formed. Mucilage and paste which has been made for some time are not good for pasting the letters. Mucilage turns the paper yellow and the old paste is lumpy.

Use a fine brush to put the paste on the letters, and then use fine forceps (fig. 70) to pick up the letters and transfer them to the proper position. Press down with the finger covered with tissue paper or very fine cloth or with fine blotting paper. Press directly downward or the letter is liable to be displaced or distorted by a lateral thrust.

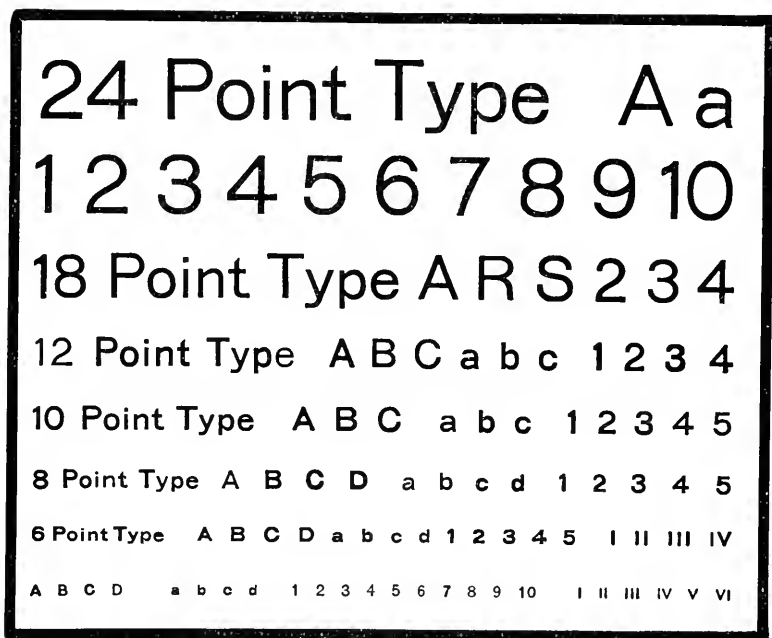

FIG. 116 A. GOTHIC TYPE FOR LETTERING DRAWINGS.

(From Optic Projection).

§ 304. **White letters for black background.** — The white letters, words, or numerals are most easily procured by photography. The letters, words, etc., are printed on tissue paper. This is used as a negative by placing it face down on a glass plate and in a printing frame. Use some developing paper like Cyco, Velox, etc., of the contrast variety. Print as for any negative and develop with a contrast developer so that the whites and blacks will be perfect. The white

letters, etc., are then cut out and pasted on the drawing as described above. This photographic paper is rather thick and will show a white edge where it is cut. Blacken the white edges of the letters or words with India ink after the letters are stuck in place (fig. 106).

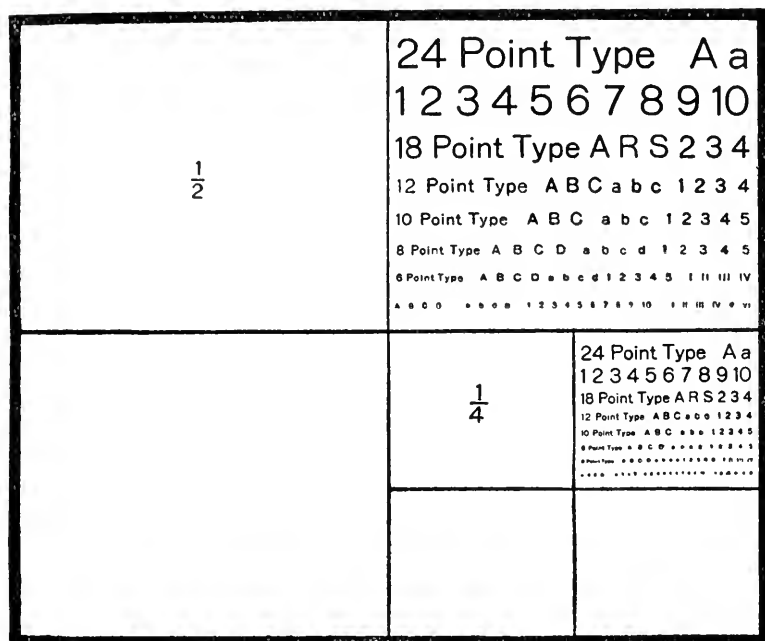

FIG. 116 B. THE GOTHIC TYPE IN FIG. 116 A, REDUCED TO ONE-HALF AND TO ONE-FOURTH NATURAL SIZE.

(From Optic Projection).

CLASS DEMONSTRATIONS

§ 305. **Demonstration microscopes.** — Ever since the microscope was invented physicians and naturalists have made the greatest use of it for demonstration purposes. It was a favorite expression of the older writers that the instrument had created a new world of the minute. Naturally in the beginning each person used the instrument for himself as with the simple microscopes of Roger Bacon.

However, soon after the invention of the compound microscope Kepler and Scheiner discovered the way to get projection pictures, and these have been much used for demonstrating to groups of people the enlarged screen pictures.

Recently the powerful lime and electric lights have made it possible to carry on these demonstrations to an extent beyond the hopes of the earlier workers; and have put facilities for helping students into the hands of the teacher which are beyond estimation in value. Still for many things and for many persons having charge of large classes the individual simple or compound microscope is still and always will be much used.

DEMONSTRATION MICROSCOPES AND INDICATORS

§ 306. **Simple Microscope.** — Holding the simple microscope in one hand and the specimen in the other has always been used for demonstration, but for class demonstration it is necessary to have microscope and specimen together or the part to be observed by the class is frequently missed. Originally blocks of various kinds to hold both microscope and specimen were devised, but within the last few years excellent pieces of apparatus have been devised by several opticians for the purpose. The accompanying figure shows one of the best forms.

The tripod magnifier and various pocket magnifiers are excellent for the purpose (fig. 17-18). Where the microscope and object should be held in a fixed position the focusing stand for the simple microscope is good (fig. 19).

§ 307. **Compound demonstration microscope.** — This was originally called a clinical or pocket microscope. It is thus described by Mayall in his Cantor Lectures on the history of the microscope: "A small microscope was devised by Tolles for clinical purposes which seems to me so good in every way that I must ask special attention for it. The objective is screwed into a sliding tube, and for roughly focusing the sliding motion suffices; for fine adjustment, the sheath is made to turn on a fine screw thread on a cylindrical tube, which serves also as a socket carrier for the stage. The compound microscope is here reduced to the simplest form I have met

with to be a really servicable instrument for the purpose in view; and the mechanism is of thoroughly substantial character. I commend this model to the notice of our opticians."

Since its introduction by Tolles many opticians have produced excellent demonstration microscopes of this type, but most of them have not preserved a special mechanism for fine adjustment. With it one can demonstrate with an objective of 6 mm. satisfactorily. It has a lock, so that once the specimen is in the right position and the instrument focused it may be passed around the class. For observation it is only necessary for each student to point the microscope toward a window or a lamp.

A modification of this clinical microscope was made by Zentmayer in which the microscope was mounted on a board, and a lamp for illuminating the object was placed at the right position.

§ 308. **Traveling Microscope.** — For many years the French opticians have produced most excellent traveling microscopes. The opticians of other countries have also brought out serviceable instruments. For the needs of the pathologist and sanitary inspector a microscope must possess compactness and also the qualities which render it usable for nearly all the purposes required in a laboratory. This instrument is a type of much apparatus which has grown up with the needs of advancing knowledge.

§ 309. **Indicator or pointer ocular.** — This is an ocular in which a delicate pointer of some kind is placed at the level where the real image of the microscope is produced. It is placed at the same level

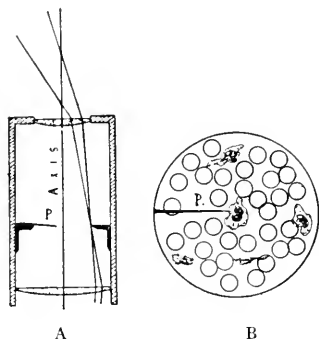

Fig. 117 A, B. POINTER OCULAR AND FIELD WITH POINTER.

FIG. 117 A. POINTER OR INDICATOR OCULAR WITH A CAMEL'S HAIR (*P*) STUCK TO THE OCULAR DIAPHRAGM AND EXTENDING OUT INTO THE OPEN SPACE WHERE THE REAL IMAGE IS FORMED.

FIG. 117 B. THE MICROSCOPIC FIELD OF A BLOOD PREPARATION WITH THE POINTER (*P*) DIRECTED TOWARD A LEUCOCYTE.

as the ocular micrometer, and the pointer like the micrometer is magnified with the real image and appears as a part of the projected image (fig. 117 B). By rotating the ocular or the pointer any part of the real image may be pointed out as one uses a pointer on a wall or blackboard diagram. By means of the indicator eye-piece one

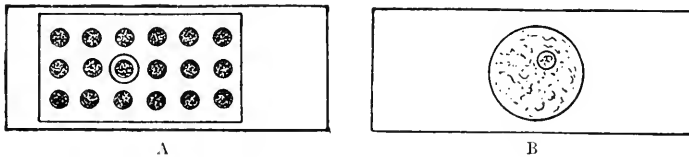

FIG. 118 A. RING AROUND ONE OF THE SECTIONS OF A SERIES FOR DEMONSTRATING SOME ORGAN ESPECIALLY WELL.

FIG. 118 B A MICROSCOPIC PREPARATION WITH A RING AROUND A SMALL PART TO SHOW THE POSITION OF SOME STRUCTURAL FEATURE.

can be certain that the student sees the desired object, and is not confused by the multitude of other things present in the field. This device has been invented many times. It illustrates well the adage: "Necessity is the mother of invention," for what teacher has not been in despair many times when trying to make a student see a definite object and neglect the numerous other objects in the field? So far as the writer has been able to learn, Quekett was the first to introduce an indicator ocular with a metal pointer which was adjustable and could be turned to any part of the field or wholly out of the field.

It is not known who adopted the simple device of putting a fine hair on the diaphragm of the ocular, as shown in fig. 117. This may be done with any ocular, positive or negative. One may use a little mucilage, Canada balsam, or any other cement to stick the hair on the upper face of the diaphragm so that it projects about halfway across the opening. When the eye-lens of the Huygenian ocular is screwed back in place the hair should be in focus. If it is not, screw the eye-lens out a little and look again. If it is not now sharp, the hair is a little too high and should be depressed a little. If it is less distinct on screwing out the ocular it is too low and should be

elevated. One can soon get it in exact focus. Of course it may be removed at any time.

§ 310. **Marking the position of objects.**—In order that one may prepare a demonstration easily and certainly in a short time the specimens to be shown must be marked in some way. An efficient and simple method is to put rings of black or colored shellac around the part to be demonstrated. For this the Marker (fig. 59-60) is employed. For temporary marking an ink line may be put on with a pen; or a glass pencil may be used.

THE PROJECTION MICROSCOPE

311. **Projection Microscope.**—One of the most useful and satisfactory means at the disposal of the teacher of Microscopic Anatomy and Embryology for class demonstrations is the Projection Microscope. With it he can show hundreds of students as well as one, the objects which come within the range of the instrument.

It is far more satisfactory than microscopic demonstrations, for with the projection microscope the teacher can point out on the screen the structural features and organs which he wishes to demonstrate, and he can thus be certain that the students know exactly what is to be studied. Unless one employs a pointer ocular (fig. 117), there is no certainty that the student selects from the multitude of things in the microscopic field the one which is meant by the teacher. Like all other means, however, the projection microscope is limited. With it one can show organs both adult and embryonic, and the general morphology. For the accurate demonstration of cells and cell structure the microscope itself must be used. As a general statement concerning the use of the projection microscope for demonstration purposes, it may be said that it is entirely satisfactory for objects and details which show under the microscope with objectives up to 16 mm. equivalent focus. For objects and details requiring objectives higher than 16 mm. focus in ordinary microscopic observations, the projection microscope is unsatisfactory with large classes.

With small classes (10 or 15) where the screen distance can be reduced to about one meter demonstrations with oil immersion objectives are satisfactory. However, when the finest details of

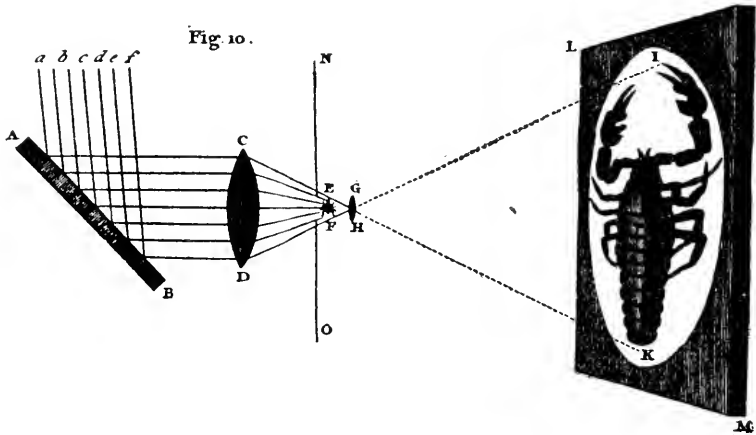

FIG. 119. DIAGRAM OF ADAMS' SOLAR MICROSCOPE. THIS ILLUSTRATES WELL THE ADVANTAGE OF SOME FORM OF PROJECTION MICROSCOPE FOR DEMONSTRATION PURPOSES.

structure are to be seen most successfully under high powers, each individual must look into a microscope for himself and attend to all the finer adjustment and lighting.

CONDUCT OF A DEMONSTRATION WITH THE PROJECTION MICROSCOPE

§ 312. **Preparedness.**—From the great difficulty in making really good projection demonstrations with the microscope the preparation should be thorough. The following are some of the most important things to look after:

(1) If any of the objectives used are of the photographic type and have an iris diaphragm, that should be opened to the fullest possible extent.

(2) The microscopic slides to be used should be in order so that they can be easily grasped.

(3) If the slides have many sections upon them, as in a series, then the slide should be masked by putting some orange paper over the cover glass with openings for the sections to be shown; then these can be found quickly and with certainty (fig. 120, § 312a).

(4) Indicate in some way which edge of the slide should be up. This will save time, and add to the respect for the exhibition.

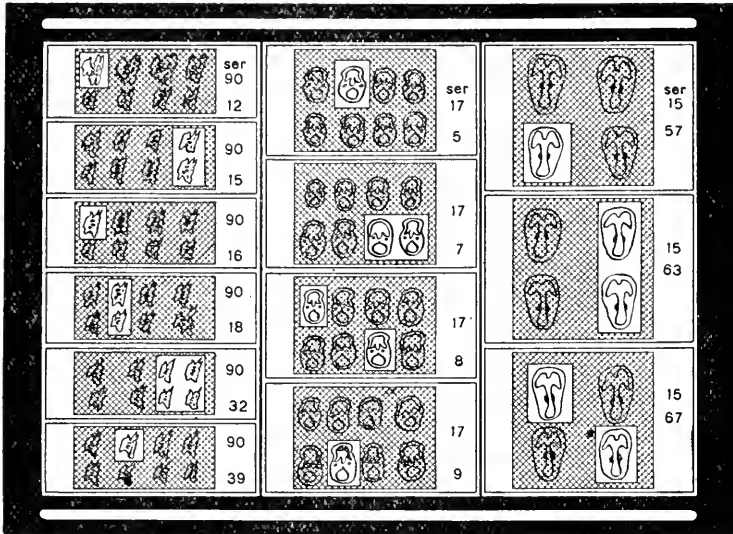

FIG. 120. SLIDE TRAY WITH MASKED PREPARATIONS TO BE USED IN A DEMONSTRATION.

(From Optic Projection).

(5) It is often a great help to have stated on the preparation the objectives best adapted to bring out the special feature desired.

(6) For holding the specimens, a slide tray may be used (fig. 120) or one of the slide boxes. In any case they must be so that the slides can be easily grasped.

(7) It is for many lecturers easier to manipulate the projection microscope themselves and to use a pointer held out in the cone of light. The pointer appears as sharply as when put on the screen.

(8) For all but the highest powers a substage condenser is not needed; and one can light objects up to 50 or 60 mm. in diameter if the object is placed in the right position in the cone of light (fig. 124).

(9) For objectives of higher power than 4 mm. a substage condenser should be used, and if an ocular is used as well as an objective then the substage condenser is advantageous for powers above 8 mm. equivalent focus. For lighting see § 104, 107, 352.

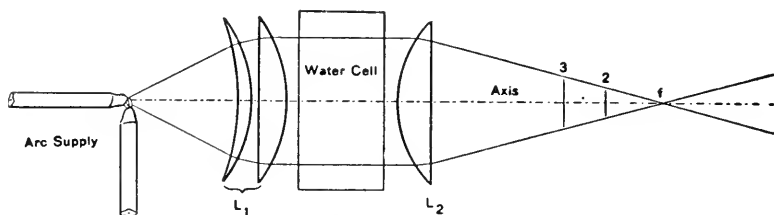

FIG. 121. ILLUMINATING OBJECTS OF VARIOUS SIZES IN MICRO-PROJECTION WITH THE MAIN CONDENSER ONLY.

(From Optic Projection).

The object must be put in the cone of light at a point where it will be fully illuminated.

For high powers it will be at or very near the focus (f). For larger objects and low powers at 2 or 3, or even closer to the condenser face.

Arc Supply The right-angled carbons of the arc lamp.

L_1 L_2 The first and second elements of the triple condenser.

Water Cell The water cell for absorbing radiant heat. It is in the parallel beam between the first and second elements of the condenser.

Axis The principal optic axis on which all the parts are centered.

(10) One of the most important points is to have a very white screen. A cloth or wall screen painted with Artist's Scenic White gives a very perfect screen which does not yellow with age, and its primitive whiteness is restored by an occasional coat of fresh white. Semi-mirror screens are successful only in narrow rooms.

For short screen distances (1 or 2 meter screen distances) white cardboard or a sheet of very white bristol board gives excellent results.

The apparatus, in contrast to the screen, should be dull black.

§ 312a. **Masks for demonstration slides.** — The paper to use should allow the red and orange to pass, but cut off the green-blue end of the spectrum. An

excellent masking paper can be prepared by soaking white paper in a saturated aqueous solution of Orange G for 10 to 15 minutes, and then hanging it up until dry. The paper is then cut into pieces the size of the cover-glass. Holes are made opposite the sections to be demonstrated (fig. 120), and the paper pasted to the cover-glass. It is put on the cover-glass and not on the under side of the slide because if on the slide it would prevent the conduction of the heat absorbed. If the slide rests against the metal or glass stage the absorbed heat is largely conducted away by the stage water cell or the metal stage.

If one wishes to remove the mask from the cover the safest way is to place a piece of wet blotting paper on the mask to soften it. It can then be easily removed and the cover-glass cleaned with a moist cloth.

§ 313. Objectives, oculars, and amplifiers to use in projection. —

Objectives of the photographic type from 100 to 16 mm. equivalent focus are unexcelled. They should not be used with oculars. Of ordinary objectives, all powers can be used, but for demonstrations before large classes a 4 mm. is the highest power found really satisfactory. The ones most used are of 16, 10, 8 mm. focus. Oculars of the projection or the ordinary type answer well. If the projection type is used one must rotate the eye-lens until there is a sharp image of the diaphragm on the screen to get the best image of the object.

If one is to use an amplifier with the objective, but no ocular, the increase in size should not be over 1.5 to 2.5 beyond that given by the objective. For example if the screen image with the objective alone were 500 diameters, the amplifier should not enlarge it beyond 750 or 1000.

The ones used by the author are for the large tube of the microscope (fig. 112) and are nearly 5 cm. in diameter to fit the microscope tube. Their virtual foci are 20 and 10 cm. (5 and 10 diopter concaves).

§ 314. Centering the optical parts on one axis. — This is one of the most important procedures of all and no good projection can be accomplished without it. The easiest way is to first arrange the crater of the arc lamp, the central point of the large condenser, and the microscope objective all at the same height from the base board (fig. 111). If then the lamp is turned on and the objective placed in the focus of the main condenser cone, the image of the crater of the arc lamp should be formed on the end of the objective, the brightest part on the front lens. If the image is to one side, above or below, then the microscope should be raised, or lowered. After being once

carefully centered, the centering will vary slightly with the burning of the carbons. To compensate for this there must be fine adjustments to raise and lower the carbons and to move them from side to

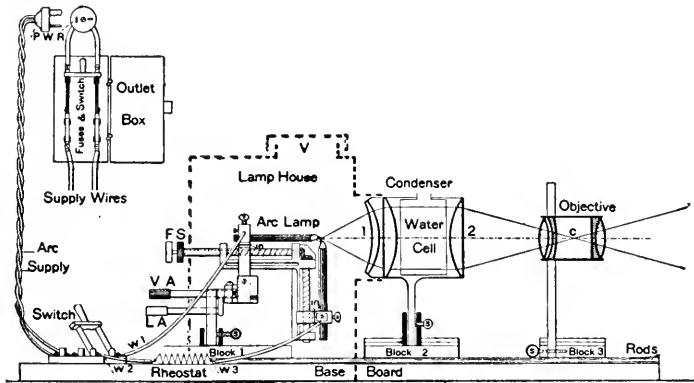

FIG. 122. PROJECTION APPARATUS SHOWING THE PARTS AND THE WIRING FOR AN ARC LAMP.

(From Optic Projection).

The *Objective*, *Condenser*, and *Arc Lamp* are on separate blocks which move independently along the optical bench (fig. 131).

c Center of the objectives where the rays from the condenser should cross.

1, 2 The first and second elements of the three condenser with a water cell for absorbing radiant heat between the lenses.

V The ventilating hood of the lamp house.

LA, VA The mechanism for fine adjustment of the arc lamp to the sides and vertically. These are a necessity for projecting with the microscope, otherwise the crater cannot be kept centered.

FS The fine adjustments for the two carbons.

PWR Separable attachment for the wires from the outlet box to the table switch.

W₁ Wire from the table switch to the upper carbon.

W₂ Wire from the table switch to the rheostat.

W₃ Wire from the rheostat to the lower carbon.

side. No good projection can take place unless the full cone of light shines upon the end of the objective.

To get the very best effect in the easiest way there should be a dull black shield over the end of the objective (fig. 123) so that the image of the crater can be seen without hurting the eyes. When the crater is focused on the end of the objective the specimen is moved up until

it is in focus, the objective not being moved. Of course this means that the stage must be separately movable (fig. 109). See also § 296.

§ 315. **Demonstrations with a vertical projection microscope.** — Many specimens must be mounted in liquids and cannot be set in a vertical position; therefore the microscope must be vertical and the object remain horizontal. In such a case project the light from

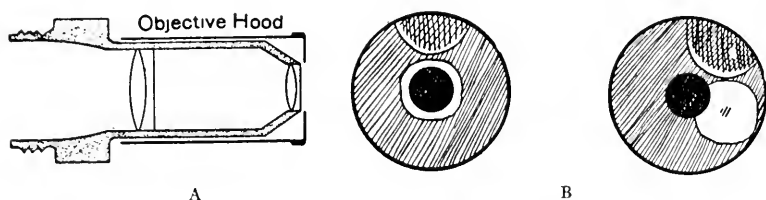

FIG. 123 A, B. METAL HOOD OVER THE OBJECTIVE TO AID IN CENTERING THE LIGHT.

(From Optic Projection).

A Longitudinal section of the objective to show the metal hood.

B End view of the objective with the crater of the arc lamp directly in the center at the left and to one side of the center at the right. The adjustments, *V*, *A*, *L*, *A* in fig. 122 are to enable one to center the light easily.

the large condenser (fig. 111) or from the small arc lamp (fig. 49) upon the mirror of the microscope and reflect it directly upward, and then use a mirror or prism to change the direction from vertical to horizontal. (See fig. 109, 114, to recall how the beam is changed in direction 90° .)

A most striking preparation is one of the hay infusion (§ 211) projected upon the screen. A water immersion objective of 2 to 3 mm. equivalent focus is excellent for projecting such preparations.

DEMONSTRATION LANTERN AND TABLE FOR ARTIFICIAL DAYLIGHT

§ 316. **Special microscopic demonstrations.** — As stated above, if one is to see the finest details of structure there is no satisfactory way but to look into the microscope direct. There is also in every laboratory for microscopic work considerable waste space if depen-

dence is put upon daylight. If artificial light is used regularly the method here given is also applicable.

The main points for this kind of demonstration were worked out by Dr. B. F. Kingsbury for his laboratory of Histology and Embryology.

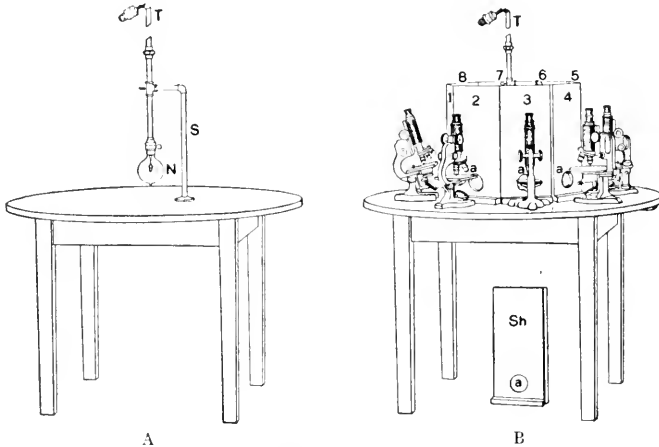

FIG. 124 A, B. KINGSBURY'S DEMONSTRATION TABLE WITH ARTIFICIAL DAYLIGHT. (ABOUT $\frac{1}{25}$ NATURAL SIZE).

(From the *Anatomical Record*, June, 1916).

T Top of the metal tube and the separable attachment plug. This tube reaches about 2 meters above the floor so that the supply cable will be out of the way.

N S The single 250 watt mazda lamp with its metal support.

1, 2, 3, 4, 5, 6, 7, 8 The shields (*Sh*) with a disc of daylight glass (*a*) in each at the level of the microscope mirror.

A round top demonstration table of a size for 8 microscopes is made and in the middle a single mazda lamp of 200 or 250 watts is installed (fig. 124 A). Around this lamp are 8 shields, each containing a piece of daylight glass.

With this arrangement 8 microscopes can be used at once (fig. 124 B) and the light is sufficient to enable the student to use all powers of the microscope up to the highest oil immersion. This method of demonstration has already been in use during the entire college year of 1915-1916 and has proved successful beyond expectation.

A simpler arrangement for four microscopes is furnished by the daylight glass lantern with a 100 watt lamp and four windows (fig. 125).

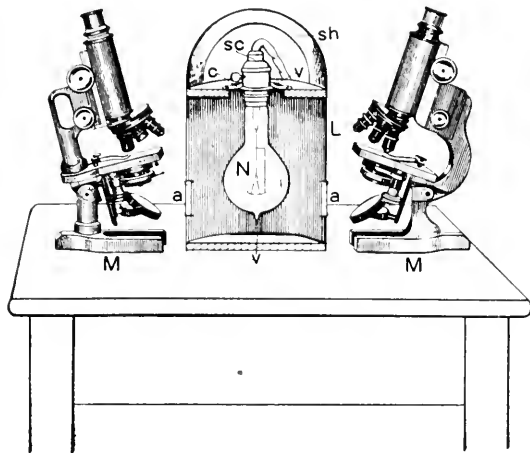

FIG. 125. LANTERN FOR DAYLIGHT GLASS TO USE WITH FOUR MICROSCOPES.

- MM* Two microscopes on opposite sides of the lantern.
aa Discs of daylight glass opposite the microscope mirrors.
N 100 Watt nitrogen-filled lamp. (See also fig. 37-38).

COLLATERAL READING FOR CH. VI.

GAGE, S. H. AND H. P., Optic Projection.
 HARDESTY, AND LEE. Laboratory drawing.

CHAPTER VII

PHOTOGRAPHING EMBRYOS AND SMALL ANIMALS; PHOTOGRAPHIC ENLARGEMENTS; PHOTOGRAPHING WITH THE MICROSCOPE

§ 325. Apparatus and material for Chapter VII. —

1. Photographic cameras, horizontal and vertical (§ 327-328).
2. Focusing stand for vertical camera (§ 333).
3. Focusing glass (§ 334).
4. Objectives for photographing embryos (§ 335).
5. Negative records (§ 337, 358).
6. Photo-micrographic camera (§ 338, 340).
7. Microscope oculars and objectives (§ 342, 343, 355).
8. Daylight lantern and other lights (§ 345, 373-374).
9. Stage micrometer (§ 350).
10. Projection apparatus (§ 359-363)
11. Photographic chemicals (§ 377).
12. Plates and printing paper (§ 362, 379-380).
13. Color screens (§ 366-368).
14. Microspectroscope (§ 371).
15. Dark-room light (§ 378).
16. Printing frames (§ 362-363).

PHOTOGRAPHY

§ 326. From the beginning of the art of photography scientific men have used it to paint for them the forms in nature and the complex structures found in the physical and the biological world; and it has been so good a servant that it is more and more called into requisition to delineate all the phenomena as well as the forms of nature and art. This is especially true now that successful methods of color photography have become available.

§ 327. **Photography with a horizontal camera.** — The most convenient position for the camera obscura is the horizontal one (fig. 108) and for most of the photography actually done it is very easy to arrange the objects to be photographed in a vertical position; but for much of the photography of science it is very convenient to use a vertical camera, leaving the objects in a horizontal position. With objects in liquids this is a practical necessity.

§ 328. **Photography with a vertical camera.** — The object can be left horizontal as well as the camera by the use of a mirror or totally reflecting prism, but this gives the inversion of a plane mirror, and as shown in § 282 it will render the image erect on the film side of the negative, but when the negative is printed the image will be inverted. To meet all the difficulties the object may be left in a horizontal position and the camera made vertical (fig. 126).

Since 1879 such a camera has been in use in the Anatomical Department of Cornell University for photographing all kinds of specimens; among these, fresh brains and hardened brains have been photographed without the slightest injury to them. Furthermore, as many specimens are so delicate that they will not support their own weight, they may be photographed under alcohol or water with a vertical camera and the result will be satisfactory as a photograph and harmless to the specimen (§ 328a).

A great field is also open for obtaining life-like portraits of water animals. Chloretoned or etherized animals are put into a vessel of water with a contrasting background and arranged as desired, then photographed. Fins have something of their natural appearance and gills of branchiate salamanders float out in the water in a natural way. In case the fish tends to float in the water a little mercury injected into the abdomen or intestine will serve as ballast. The photographs obtainable in water are almost if not quite as sharp as those made in air. Even the corrugations on the scales of such fishes as the sucker (*Catostomus teres*) show with great clearness.

While the use of photography diminishes the labor of artists about one-half, it increases that of the preparator; and herein lies one of its chief merits. The photographs being exact images of the preparations, the tendency will be to make them with greater care and delicacy, and the result will be less imagination and more reality in published scientific figures; and the objects prepared with such care will be preserved for future reference.

In the use of photography for figures several considerations arise: (1) The avoidance of distortion; (2) The adjustment of the camera to obtain an image of the desired size; (3) Focusing; (4) Lighting and arranging the object.

(1) While the camera delineates rapidly, the image is liable to distortion. I believe opticians are agreed that, in order to obtain correct photographic images, the objective must be properly made, and the plane of the object must be parallel to the plane of the ground-glass. Furthermore, as most of the objects in natural history have not plane surfaces, but are situated in several planes at different levels, the whole object may be made distinct by using a long focus objective and a small diaphragm.

§ 328a. Papers on this subject were given by the writer at the meeting of the American Association for the Advancement of Science in 1879, and at the meeting of the Society of Naturalists of the eastern United States in 1883; and in *Science* Vol. III, pp. 443, 444.

§ 329. **Scale of photographs.** — It is desirable to make all photographs at some definite scale. To do this without much waste of time the camera should be calibrated for each objective that is to be used. This is easily accomplished by using a metric scale like that shown in fig. 104. By lengthening and shortening the bellows of the camera so that the image distance is greater and less one can get the exact position for a group of magnifications and reductions. If the length of the bellows is noted for each size, and the distance, of the objective from the object when the focus is good is also noted one can arrange the camera very quickly for any special size which may be desired. The sizes found very useful by the author are: $\frac{1}{8}$; $\frac{1}{4}$; $\frac{1}{3}$; $\frac{1}{2}$; 1; 2; 2.5; 4; 5. For magnifications above 5 it is better to make a negative natural size ($x1$) and then make an enlargement of this, as explained in § 359.

The vertical camera shown in fig. 126 has the supporting rod graduated in centimeters and half centimeters. After the extension of the camera for any size has been once determined, it is easily made the same at some future time.

§ 330. **Magnification rod for the camera.** — Objects vary so much in thickness that the focusing range of the camera should be considerable. With the ordinary camera there is usually no provision for moving the camera as a whole for focusing. With the vertical camera shown in fig. 126, where both ends of the camera must be clamped, it is difficult to focus over a large range and keep the length of camera

needed for the desired magnification or reduction. For this reason the same device was applied to it as to the original vertical camera of 1879, viz., a rod passing from end to end of the camera, fixed at one end and clamped at the other. When the camera is extended the exact amount required for the size in a given case the clamp is fixed so that the length of the camera cannot be changed, then the whole camera may be moved for focusing without any danger of varying the magnification. This device saves a great deal of time and keeps one good-natured. In the original camera of 1879, the rod was graduated in centimeters. This of course helps to give the proper extension with the least outlay of trouble. In fig. 126 the vertical supporting rod is graduated in centimeters and half centimeters.

§ 331. **Lighting for the vertical camera.** — The object should be so arranged that all the details come out with the greatest distinctness. As the light must be largely from the side it is often necessary to put a piece of white blotting paper or cardboard on the side of the specimen opposite the window. Occasionally for lighting up deep cavities it is a great advantage to use a mirror and reflect sunlight into the cavities for a part of the exposure.

Great care must be taken in selecting a suitable background so that the specimen will stand out clearly and not be merged into the background.

When a white background is used, the shadow of the specimen is often very troublesome, and to distinguish the outline of the object W. E. Rumsey (Canadian Entomologist, 1896, p. 84) hit upon the plan of placing the object on a glass plate and putting the background on a stage below (fig. 126). A background on the lower stage does away with the confusion. If daylight is not available excellent photographs can be obtained with mazda lamps with metallic or white reflectors to direct the light. It is usually better to employ two portable lamps and arrange them so that the shadows will not be too prominent.

§ 332. — **Photographing embryos, small animals, and organs.** — The camera shown in fig. 126 is admirably adapted for this, as the objects, many of them, must be photographed under water, alcohol, or other liquids.

If one has a good place to do the work in, the light can usually be arranged satisfactorily with the object in a vessel with a proper background in the bottom. If not, a double stage must be used, as shown in fig. 126.

If white embryos or other light objects are to be photographed a black background is best. This is produced by using black glass on the bottom of the dish. Or if no black glass is available, some smooth paper is coated with waterproof India ink and allowed to dry. This gives good contrast.

With a proper background make sure that the lighting is such as to bring out the desired details. Turn the object in various positions till the desired one is found which shows clearly the points that are to be emphasized.

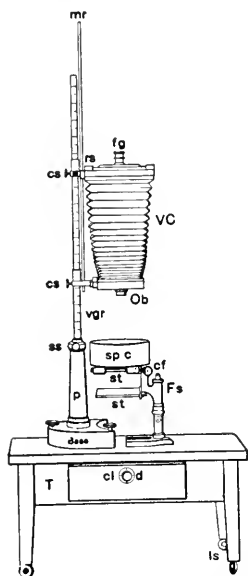

FIG. 126. VERTICAL PHOTOGRAPHIC CAMERA.

T Low table 50 cm. high, 50 cm. wide, and 70 cm. long.

Fs Focusing stand with vessel for holding embryos and small animals to be photographed under liquid.

VC Vertical camera with an objective (*ob.*) in the lower end and a focusing glass (*fg*) above. (See fig. 107 for fuller description.)

§ 333. **Focusing stand for the vertical camera.** — To hold the specimen and to provide for the finest focusing, and also some of the coarse focusing, a modified microscope stand is convenient. It has no tube, but two stages are attached to the support usually carrying the tube. This then can be raised and lowered by the coarse and by the fine adjustment, as in focusing the microscope, except here the stages move, the photographic objective remaining stationary (fig. 126). With the rod to hold the camera at a fixed extension, most of the focusing can be accomplished by sliding the whole camera up and down the vertical graduated support (fig. 126).

§ 334. — **Focusing glass.** — There are two ways of using this:

1. A clear screen is used instead of a ground-glass. On this is a diamond scratch in the middle. The focusing glass is carefully

focused on the central scratch, which must be in the exact plane where the sensitized photographic surface will be during the exposure. If now an object is brought to an accurate focus at this plane, it will also be in focus on the sensitized surface of the dry plate. Except for aid in arranging the object and for general focusing, the frosted glass can be entirely omitted, and a focusing glass giving about 8 to 10 diameters magnification is set in a board which takes the place of the ordinary frosted glass screen. This is put at the level to bring the focus exactly at the plane where the sensitive surface of the negative is to be.

The position of the focusing glass is determined as follows:

The plate holder with a clear glass plate or a thin negative is in the holder. And on the film side is a diamond scratch or an India ink mark near the middle of the face usually occupied by the sensitive film. It is very important that the mark should be on the side occupied by the film.

The scratch or ink mark is a guide for getting the focus at the right level. Now with a tripod or other magnifier, preferably with the magnifier to be used later, get the image focused of the metric scale and its explanation or other sharp print exactly on the surface where the diamond or ink mark is. To make sure that there is no better focus obtainable it is worth while to make a negative of the printed matter used for focusing. On the excellence of the focus determined depends the excellence of all future pictures which will be made. This method has the further advantage that the focus level is determined for the plate holder and not for a focusing screen. It is in fact an

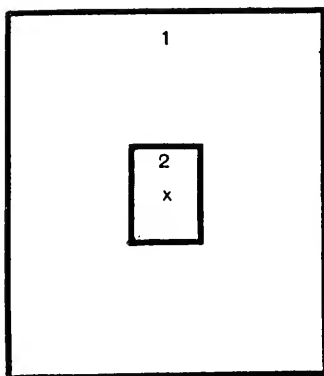

FIG. 127. GROUND-GLASS FOCUSING SCREEN WITH CLEAR CENTER FOR FINE FOCUSING.

1 The ground or frosted surface of the glass.

2 A cover-glass stuck to the frosted surface with *Canada Balsam*. This renders the frosted surface transparent.

x Pencil mark in the center of the focusing screen on the frosted surface to serve as guide when focusing with a magnifier.

excellent way to check up the similarity of level of the ordinary focusing screen and the plate holder. Frequently they do not agree closely enough for the more exacting work, especially in photo-micrography. If the focus is found to be exact proceed to set the focusing glass in a board as follows:

Have a board of about 15 mm. thickness in a frame like that used for the ordinary focusing screen. Bore a hole in the center in which the focusing glass holder will fit snugly. Now put the frame on the focused camera and slowly twist the focusing glass into the hole until the focus seen through it is perfect. If nothing has changed in the camera then this focus should give perfect results for any future setting of the camera, for the focus will be at the exact level occupied by the sensitive surface of the plate. If it is found perfect by trial, it is wise to put some shellac or other varnish around the mounting to fix it firmly in place in the wood so that there



FIG. 128. TRIPOD
MAGNIFIER TO SERVE
AS A FOCUSING GLASS.

will be no change in its position. Of course any change would result in imperfect, out-of-focus negatives.

This method of focusing has the great advantage of doing away with all obstructing glass. One focuses the position of the real image exactly as for a compound microscope when a positive ocular (fig. 22) is used. It is an invaluable way for focusing in photo-micrography.

§ 335. **Objectives and magnification for embryos.** — It is a good plan to have one picture of natural size in each case, and then if the embryos or other objects are very small, a picture of 5 or more times natural size. And a picture should go with the embryo or object throughout its entire career so that the exact appearance before sectioning or dissection will be available.

Objectives for making photographs of from x_1 to x_5 range from 50 to 100 mm. equivalent focus, and they are placed in the end of the camera as usual (fig. 126). The larger the object the longer should be the focus of the objective; then the exaggerated perspective of short focused lenses will be avoided.

§ 336. **Photographing bacterial cultures.**— For the successful photographing of these cultures dark-ground illumination is employed on the principle stated in § 117. That is, the preparation is illuminated with rays so oblique that none can enter the objective directly. These striking the culture are reflected into the objective. The clear gelatin around the growth or colonies does not reflect the light and therefore the space between the colonies is dark.

For supporting the Petri dishes a hole is made in a front board for the camera. This hole is slightly larger than the dish. Over it is then screwed or nailed a rubber ring slightly smaller than the Petri dish. This will stretch and receive the dish, and grasp it firmly, so that it is in no danger of falling out when put in a vertical position. If the camera has two divisions like the one shown, the board with the Petri dish is put in the front of the camera, and the objective in the middle division through the side door. Otherwise the board holding the Petri dish must be on a separate support (fig. 108).

The vertical camera and focusing stand (fig. 126) lend themselves admirably for this kind of photography. The black background can be put on the lower stage and the Petri dish or other bacterial culture can be set on a glass plate or in a perforated board on the upper stage. The lighting is very easily accomplished by two portable lamps so arranged that no light can get directly from them into the objective.

One may use daylight by putting the culture in a support just outside a window, leaving the camera in the room. The rays from the sky are so oblique that they do not enter the objective. One must use a black non-reflecting background some distance beyond the dish as in using artificial light (Atkinson).

In photographing bacterial cultures in test-tubes the lighting is as in the preceding section, but a great difficulty is found in getting good results from the refraction and reflections of the curved surfaces. To overcome this one applies the principles discussed in § 202, and the test-tubes are immersed in a bath of water or water and glycerin. The bath must have plane surfaces. Behind it is the black velvet screen, and the light is in front, as for the Petri dishes. As suggested by Spitta, it is well to employ a bath sufficiently thick in order that

streak cultures may be arranged so that the sloping surface will all be in focus at once by inclining the test-tube.

§ 337. **Recording and storing negatives.** — Each negative should have a record upon it written on the film side with India ink; then it will never get mixed up. For ease in finding them there should be a record on the containing envelope also. Finally, it is a good plan to have a card catalogue of one's negatives. For a form see § 358.

For storing negatives a good method, where one does not have too many, is to put them in envelopes and store in boxes or drawers like book catalogue cards.

PHOTOGRAPHING WITH THE MICROSCOPE

§ 338. The first pictures made on white paper and white leather, sensitized by silver nitrate, were made by the aid of a solar microscope (1802). The pictures were made by Wedgewood and Davy, and Davy says: "I have found that images of small objects produced by means of the solar microscope may be copied without difficulty on prepared paper" (§ 338a).

Thus among the very first of the experiments in photography the microscope was called into requisition. And naturally plants and motionless objects were photographed in the beginnings of the art when the time of exposure required was very great.

Although first in the field, photo-micrography has been least successful of the branches of photography. This is due to several causes. In the first place, microscope objectives have been naturally constructed to give the clearest image to the eye; that is, the visual image, as it is sometimes called, is for microscopic observation of prime importance. The actinic or photographic image, on the other hand, is of prime importance for photography. For the majority of microscopic objects transmitted light (§ 85) must be used, not reflected light as in ordinary vision. Finally, from the shortness of focus and the smallness of the lenses, the proper illumination of the object is accomplished with some difficulty, and the fact of the lack of sharpness over the whole field with any but the lower powers have combined to make photo-micrography less successful than ordinary macro-photography. So tireless, however, have been the efforts

of those who believed in the ultimate success of photo-micrography, that now the ordinary achromatic objectives with panchromatic or isochromatic plates and a color screen give good results, while the apochromatic objectives with projection oculars give excellent results, even in hands not especially skilled. The problem of illumination, has also been solved by the construction of achromatic and apochromatic condensers and by the electric and other powerful lights now available. There still remains the difficulty of transmitted light and of so preparing the object that structural details stand out with sufficient clearness to make a picture which approaches in definiteness the drawing of a skilled artist.

The writer would advise all who wish to undertake photo-micrography seriously to study samples of the best work that has been produced. Among those who showed the possibilities of photo-micrographs was Col. Woodward of the U. S. Army Medical Museum. The photo-micrographs made by him and exhibited at the Centennial Celebration at Philadelphia in 1876 serve still as models, and no one could do better than to study them and try to equal them in clearness and general excellence. According to the writer's observation no photo-micrographs of histologic objects have ever exceeded those made by Woodward, and most of them are vastly inferior. It is gratifying to state, however, that at the present time many original papers are partly or wholly illustrated by photo-micrographs, and no country has produced works with photo-micrographic illustrations superior to those in "Wilson's Atlas of Fertilization and Karyokinesis" and "Starr's Atlas of Nerve Cells," issued by the Columbia University Press.

Most excellent photo-micrographs appear at frequent intervals in all the great biological journals. These should be studied by the young photographer ambitious to equal and then to excel the best.

§ 338a. Considerable confusion exists as to the proper nomenclature of photography with the microscope. On the Continent the term micro-photography (micro-photographie) is very common, while in English photo-micrography and micro-photography mean different things. Thus: A *photo-micrograph* is a photograph of a small or microscopic object usually made with a microscope and of sufficient size for observation with the unaided eye; while a *micro-photograph* is a small or microscopic photograph of an object, usually a large object, like a man or woman, and is designed to be looked at with a microscope.

Dr. A. C. Mercer, in an article in the Proc. Amer. Micr. Soc., 1886, p. 131, says that Mr. George Shadbolt made this distinction. See the Liverpool and Manchester *Photographic Journal* (now *British Journal of Photography*), Aug. 15, 1858, p. 203; also Sutton's *Photographic Notes*, Vol. III, 1858, pp. 205-208. On p. 208 of the last, Shadbolt's word "Photo-micrography" appears. Dr. Mercer puts the case very neatly as follows: "A *Photo-Micrograph* is a *macroscopic* photograph of a *microscopic* object; a *micro-photograph* is a *microscopic* photograph of a *macroscopic* object." See also *Medical News*, Jan. 27, 1894, p. 108.

In a most interesting paper by A. C. Mercer on "The Indebtedness of Photography to Microscopy," *Photographic Times Almanac*, 1887, it is shown that: "To briefly recapitulate, photography is apparently somewhat indebted to microscopy for the first fleeting pictures of Wedgwood and Davy [1802], the first methods of producing permanent paper prints [Reede, 1837-1839], the first offering of prints for sale, the first plates engraved after photographs for the purpose of book illustration [Donne & Foucault, 1845], the photographic use of collodion [Archer & Diamond, 1851], and finally, wholly indebted for the origin of the gelatino-bromide process, greatest achievement of them all [Dr. R. L. Maddox, 1871]. See further for the history of Photo-micrography, Neuhauss, also Bousfield.

§ 339. As the difficulties of photo-micrography are so much greater than of ordinary photography, the advice is almost universal that no one should try to learn photography and photo-micrography at the same time, but that one should learn the processes of photography by making portraits, landscapes, copying drawings, etc., and then when the principles are learned one can take up the more difficult subject of photo-micrography with some hope of success.

The advice of Sternberg is so pertinent and judicious that it is reproduced: "Those who have had no experience in making photo-micrographs are apt to expect too much and to underestimate the technical difficulties. Objects which under the microscope give a beautiful picture which we desire to reproduce by photography may be entirely unsuited for the purpose. In photographing with high powers it is necessary that the objects to be photographed be in a single plane and not crowded together and overlying each other. For this reason photographing bacteria in sections presents special difficulties and satisfactory results can only be obtained when the sections are extremely thin and the bacteria well stained. Even with the best preparations of this kind much care must be taken in selecting a field for photography. It must be remembered that the expert microscopist, in examining a section with high powers, has his finger on the fine adjustment screw and focuses up and down to

bring different planes into view. He is in the habit of fixing his attention on the part of the field which is in focus and discarding the rest. But in a photograph the part of the field not in focus appears in a prominent way, which mars the beauty of the picture."

APPARATUS FOR PHOTO-MICROGRAPHY

§ 340. **Camera.** — For the best results with the least expenditure of time one of the cameras especially designed for photo-micrography is desirable, but is not by any means indispensable for doing good work. An ordinary photographic camera, especially the kind known as a copying camera, will enable one to get good results, but the trouble is increased, and the difficulties are so great at best that one would do well to avoid as many as possible and have as good an outfit as can be afforded (fig. 129).

The first thing to do is to test the camera for the coincidence of the plane occupied by the sensitive plate and the ground-glass or focusing screen. Cameras even from the best makers are not always correctly adjusted.

For the method of procedure see above, § 334.

The majority of photo-micrographs do not exceed 8 centimeters in diameter and are made on plates 8×11 , 10×13 , or 13×18 centimeters ($3\frac{1}{4} \times 4\frac{1}{4}$ in., 4×5 in., or 5×7 in.).

For pictures larger than these it is best to make small, very sharp negatives of moderate enlargement and then print these at any desired size by means of projection apparatus (see under enlargements, § 359).

§ 341. **Work Room.** — It is almost self-evident that the camera must be in some place free from vibration. A basement room where the camera table may rest directly on the cement floor or on a pier is excellent. Such a place is almost necessary for the best work with high powers. For those living in cities, a time must also be chosen when there are no heavy vehicles moving in the streets. For less difficult work an ordinary room in a quiet part of the house or laboratory building will suffice. It helps much to have rubber corks in the lower ends of the table legs. The legs may also be made to stand on four thick pads of rubber or of thick woolen cloth.

Finally the camera and microscope can be placed on a board platform and that put into a shallow box nearly filled with sawdust or dry sea sand.

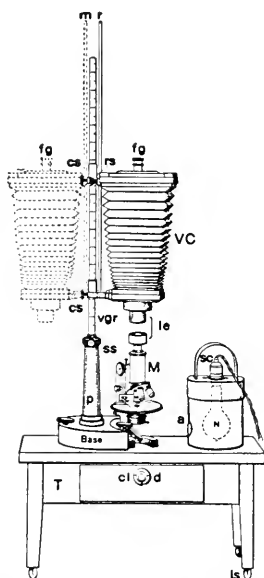

FIG. 129. VERTICAL MICROSCOPE AND CAMERA FOR PHOTO-MICROGRAPHY.
(About $\frac{1}{20}$ natural size).

T Low table 50 cm. high, 50 cm. wide, and 70 cm. long with leveling screws in the legs (*ls*) and a drawer with combination lock (*cl d*).

M Microscope.

N Nitrogen-filled mazda lamp of 100 watts in lantern for artificial daylight glass (*a*); (*sc*) lampsocket and supply cable.

VC Vertical camera supported by the revolving rod (*vgr*) which is graduated in centimeters and half centimeters. The camera may be turned aside as shown by the dotted lines.

Base The heavy iron base and pillar (*p*) supporting the revolving rod (*vgr*), which in turn supports the camera.

cs Clamping screws to fix the two ends of the camera in any desired position.

mr Magnification rod. This serves to hold the extension of the camera at the right point for any desired magnification, then the camera as a whole moves up and down on the graduated rod (*vgr*).

rs Clamp to fix the camera at any desired extension on the magnification rod (*mr*).

fg Focusing glass (§ 334).

le Light excluder (fig. 133-134).

The photo-engravers have overcome vibrations by suspending their cameras, or using spring coils as a part of the support. In case of real need this method would serve the photographer with the microscope. The whole apparatus must be suspended or supported on springs, so that any vibration will be equal for all parts. The small table and vertical camera lend themselves to either suspension or support on a platform with spiral springs, or the microscope and camera can stand directly on the platform (fig. 130).

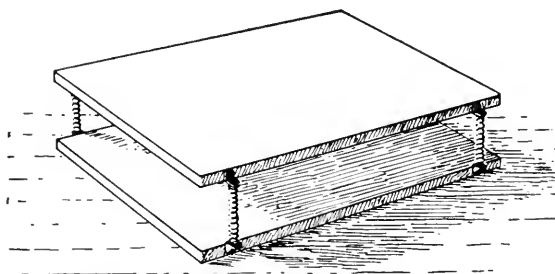

FIG. 130. PLATFORM WITH SPIRAL SPRINGS FOR THE CAMERA TO NULLIFY VIBRATIONS IN PHOTOGRAPHING.

§ 342. **Arrangement and position of the camera and the microscope.** — For much photo-micrography a vertical camera and microscope are to be preferred. Excellent arrangements were perfected long ago, especially by the French. (See Moitessier).

Vertical photo-micrographic cameras are now commonly made, and by some firms only vertical cameras are produced. They are exceedingly convenient, and do not require so great a disarrangement of the microscope to make the picture as do the horizontal ones. The variation in size of the picture in this case is mostly obtained by the objective and the projection ocular rather than by length of bellows. It must not be forgotten, however, that penetration varies inversely as the *square* of the power, and only inversely as the numerical aperture; consequently there is a real advantage in using a low power of great aperture and a long bellows rather than an objective of higher power with a short bellows. A horizontal camera is more convenient for use with the electric light also (fig. 131).

For convenience and rapidity of work a microscope with mechanical stage is necessary; and for sections where it is desirable to have the image in some regular position a revolving stage to the microscope helps greatly in orienting the image on the plate.

It is also an advantage to have a tube of large diameter so that the field will not be too greatly restricted (fig. 111). In some microscopes the tube is removable almost to the nose-piece to avoid interfering

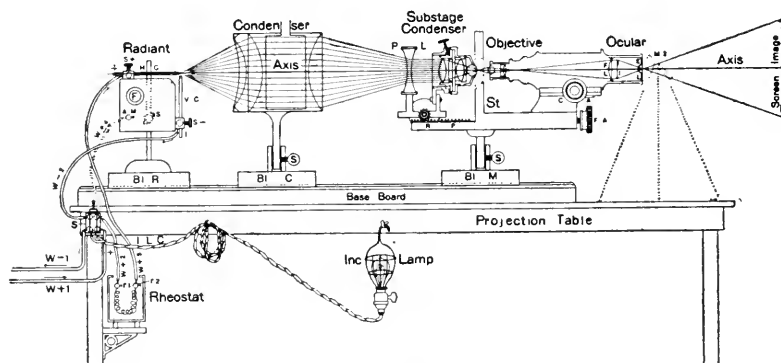

FIG. 131. HORIZONTAL PROJECTION MICROSCOPE FOR DRAWING AND FOR PHOTO-MICROGRAPHY.

(About $\frac{1}{10}$ natural size. From Optic Projection).

The wiring is for an arc lamp with right-angled carbons. The condenser has three lenses and a water cell between the two plano-convex ones.

P L Concave parallelizing lens to supply the substage condenser with parallel beams. (See also fig. 115).

M₂ 45° mirror in dotted lines beyond the ocular to reflect the image down upon the surface of the table for drawing.

with the size of the image. The substage condenser should be movable on a rack and pinion. The microscope should have a flexible pillar for work in a horizontal position. While it is desirable in all cases to have the best and most convenient apparatus that is made, it is not by any means necessary for the production of excellent work. A simple stand with flexible pillar and good fine adjustment will answer.

§ 343. Objectives and oculars for photo-micrography. — The belief is almost universal that the apochromatic objectives are most

satisfactory for photography. They are employed for this purpose with a special projection ocular. Two low powers are used without any ocular. Some of the best work that has ever been done, however, was done with achromatic objectives (work of Woodward and others). One need not desist from undertaking photo-micrography if he has good achromatic objectives. From a somewhat extended series of experiments with the objectives of many makers the good modern achromatic objectives were found to give excellent results when used without an ocular. Most of them also gave good results with pro-

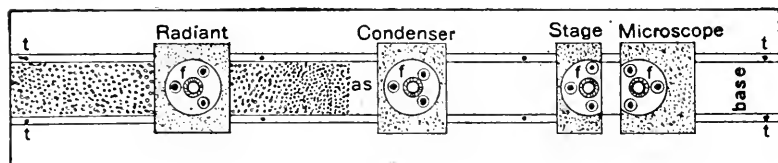

FIG. 132. HOME-MADE OPTICAL BENCH.

(About $\frac{1}{10}$ natural size. From Optic Projection).

This is composed of a baseboard on which are fastened two rods (*t t t t*) to serve as a track along which the different apparatus blocks can be moved.

The shaded part (*as*) is covered with asbestos paper to avoid any danger from fire.

ff The flanges holding the sockets for inserting the different pieces of apparatus. (Compare fig. 109-112, 131).

jection oculars. It must be said, however, that the best results were obtained with the apochromatic objectives and projection oculars. The compensation oculars also give good results. It does not seem to require so much skill to get good results with apochromatics as with achromatic objectives. The majority of photo-micrographers do not use the Huygenian oculars in photography, although excellent results have been obtained with them. An amplifier is sometimes used in place of an ocular. Considerable experience is necessary in getting the proper mutual position of objective and amplifier. The introduction of oculars especially designed for projection has led to the discarding of ordinary oculars and of amplifiers. Oculars restrict the field very greatly; hence the necessity of using the objective alone for large specimens.

§ 344. **Difference of visual and actinic foci.** — Formerly there was much difficulty experienced in photo-micrographing on account of the difference in actinic and visual foci. Modern objectives are less faulty in this respect and the apochromatics are practically free from it. Since the introduction of orthochromatic or isochromatic plates, and in many cases the use of color screens, but little trouble has arisen from differences in the foci. This is especially true when mono-chromatic light and even when petroleum light is used. In case an objective has its visual and actinic foci at markedly different levels it would be better to discard it for photography altogether, for the estimation of the proper position of the sensitive plate after focusing is only guesswork and the result is mere chance. If sharp pictures cannot be obtained with an objective when petroleum light and orthochromatic plates are used, the fault may not rest with the objective, but with the plate holder and focusing screen. They should be very carefully tested to see if there is coincidence in position of the focusing screen and the sensitive film as described in § 334.

LIGHTING FOR PHOTO-MICROGRAPHY

§ 345. **Light.** — The best light is sunlight. That has the defect of not always being available, and of differing greatly in intensity from hour to hour, day to day, and season to season. The sun does not shine in the evening when many workers find the only opportunity for work. Following the sunlight the electric light is the most intense of the available lights.

For many specimens daylight gives altogether the best results, and as natural daylight is not constantly available the photo-micrographer has now at his disposal the artificial daylight by the use of a nitrogen-filled mazda lamp and daylight glass. The lantern for this shown in fig. 129 was found to be excellent and the results obtained by its use in photographing with powers up to the 1.5 mm. homogeneous immersion were excellent. Of course any light filters which are adapted to natural daylight would serve perfectly with the artificial daylight.

For all preparations needing a yellow color screen for daylight, a petroleum or kerosene lamp gives good results for the majority of

low and moderate power work. And even for 2 mm. homogeneous immersion objectives, the time of exposure is not excessive for many specimens (40 seconds to 3 minutes). This light is cheap and easily obtained.

A lamp with flat wick about 40 mm. wide has been found most generally serviceable. For large objects and low powers the flame may be made large and the face turned toward the mirror. This will light a large field. For high powers the edge toward the mirror gives an intense light. The ordinary glass chimney answers well, especially where a shield is used (fig. 58).

In managing the light for photography with the microscope, follow the directions given in Ch. II, and under drawing in Ch. VI. See below for the use of color screens.

§ 346. **Objects suitable for photo-micrographs.** — While almost any large object may be photographed well with the ordinary camera and photographic objective, only a small part of the objects mounted for microscopic study can be photo-micrographed satisfactorily. Many objects that can be clearly seen by constant focusing with the fine adjustment appear almost without detail on the screen of the photo-micrographic camera and in the photo-micrograph.

If one examines a series of photo-micrographs the chances are that the greater number will be of diatoms, plant sections, or preparations of insects. That is, they are of objects having sharp details and definite outlines, so that contrast and definiteness may be readily obtained. Stained microbes also furnish favorable objects when mounted as cover-glass preparations, but these give color images and require a color screen.

For success with preparations of animal tissue they must approximate as nearly as possible to the conditions more easily obtained with vegetable preparations. That is, they must be made so thin and be so prepared that the cell outlines have something of the definiteness of vegetable tissue. It is useless to expect to get a clear photograph of a section in which the details are seen with difficulty when studying it under the microscope in the ordinary way.

Many sections which are unsatisfactory as wholes may nevertheless have parts in which the structural details show with satisfactory

clearness. In such a case the part of the section showing details satisfactorily should be surrounded by a delicate ring by means of a marker (fig. 59-61). If one's preparations have been carefully studied and the special points in them thus indicated, they will be found far more valuable both for ordinary demonstration and for photography. The amount of time saved by marking one's specimens can hardly be overestimated. The most satisfactory material for making the rings is shellac colored with lampblack.

Formerly many histologic preparations could not be satisfactorily photographed. Now with improved section cutters, better staining and mounting methods, and with the color screens and isochromatic and panchromatic plates (§ 380) almost any preparation which shows the elements clearly when looking into the microscope can be satisfactorily photographed. Good photographs cannot, however, be obtained from poor preparations.

In photo-micrography do not forget the three ways in which details of structure may be brought out clearly:

- (1) By difference of refraction of the object and the mounting medium (refraction images, § 137).
- (2) By differential staining (color images, § 139).
- (3) By means of dark-ground illumination (§ 117).

EXPERIMENTS IN PHOTO-MICROGRAPHY

§ 347. The following experiments are introduced to show practically just how one would proceed to make photo-micrographs with various powers, and be reasonably certain of fair success. If one consults prints or the published figures made directly from photo-micrographs it will be seen that, excepting diatoms and bacteria, the magnification ranges mostly between 10 and 150 diameters.

§ 348. **Focusing in photo-micrography.** — For rough focusing and as a guide for the proper arrangement of the object one uses a ground-glass screen, as in gross photography. With the ground-glass screen one can judge of the brilliancy and evenness of the illumination more accurately than in any other way. For final and exact focusing two principal methods are employed:

- (a). A focusing glass is used either with a clear screen or in a

board screen, as described above (§ 334). The latter method is like focusing with the compound microscope and a positive ocular. If the focusing glass is set properly the focus should be easily and accurately determined.

In whatever way one focuses for photo-micrography a difficulty often appears. No matter how perfect the focus of the microscope the picture may be out of focus. This may be due to either one of two things: (1) the focusing screen or focusing glass may not be in the right position to make the image sharp on the sensitive plate. (2) The microscope may get out of focus while the picture is being made. The reason for this change may be the gradual settling down of the tube of the microscope. This may be a fault of the fine or of the coarse adjustment. It is a good plan to focus the object carefully and after 10 or 15 minutes to see if the focus is still good. If the microscope will not stay in focus one cannot get a good picture. In that case it is necessary to study the apparatus and see which part of the mechanism is at fault.

§ 349. **Photo-micrographs of 20 to 50 diameters.** — For pictures under 15 to 20 diameters it is better to use the camera for embryos with the objective in the end of the camera, and the special microscope stand for focusing (fig. 126).

For pictures at 25 to 50 diameters one may use the microscope with a low objective, 20 to 35 mm. equivalent focus, and no ocular (fig. 111). The object is placed on the stage of the microscope and focused as in ordinary observation. If a vertical microscope is used the light from the petroleum lamp or other artificial light is reflected upward by the mirror. It may take some time to get the whole field lighted evenly. In some cases it may be advisable to discard the condenser and use the mirror only. For some purposes one will get a better light by placing the bull's eye or other condenser between the lamp and the mirror to make the rays parallel or even to make a sharp image of the lamp flame on the mirror. Remember also that in many cases it is necessary to have a color screen between the source of light and the object (§ 366).

For a horizontal camera it is frequently better to swing the mirror entirely out of the way and allow the light to enter the condenser

directly (fig. 131). When the light is satisfactory, as seen through an ordinary ocular, remove the ocular.

(a) *Photographing without an ocular.* — After the removal of the ocular put in the end of the tube a lining of black velvet to avoid

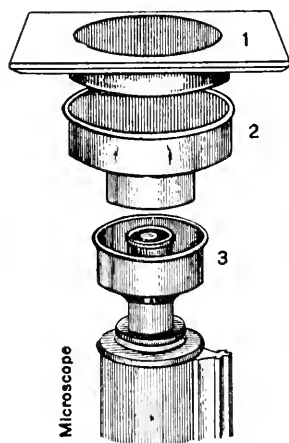

FIG. 133. LIGHT EXCLUDER FOR CONNECTING THE CAMERA AND MICROSCOPE.

(About $\frac{1}{4}$ natural size).

1 The front board of the camera.

2 Connecting piece to fit over 1 and extend down into 3.

3 Piece to fit over the upper end of the tube of the microscope and to receive the lower end of 2 (compare fig. 134 where the parts are together as in making an exposure).

reflections. Connect the microscope with the camera, making a light tight joint, and focus the image on the focusing screen. One may make a light-tight connection by the use of black velveteen or more conveniently by the double metal hood which slips over the end of the tube of the microscope, and into which fits a metal cylinder on the lower end of the camera (fig. 133-134). In figure 134 the connection has been made.

It will be necessary to focus down considerably to make the image clear. Lengthen or shorten the bellows to make the image of the desired size, then focus with the utmost care. In case the field is too much restricted on account of the tube of the microscope, remove the draw-tube. When all is in readiness it is well to wait for three to five minutes and then to see if the image is still sharply focused. If it has become out of focus simply by standing, a sharp picture could not be obtained. If it does not remain in focus, something is faulty. When the image remains sharp after focusing make the exposure. From 20 to 60 seconds

will usually be sufficient time with medium plates and light as described. If a color screen is used it will require 50-300 seconds, i. e., 2 to 5 times as long, for a proper exposure (§ 372).

(b) *Photographing with a projection ocular.* — If the object is small enough to be included in the field of a projection ocular (fig.

137), use that for making the negative as follows: Swing the camera around so that it will leave the microscope free (fig. 129). Use an ordinary ocular, focus and light the object, then insert a projection ocular in place of the ordinary one, and swing the camera back over the microscope. It is not necessary to use an ordinary ocular for the first focusing, but as its field is larger it is easier to find the part of be photographed. The first step is then to focus the diaphragm to the projection ocular sharply on the focusing screen. Bring the camera up close to the microscope and then screw out the eye-lens of the ocular a short distance. Observe the circle of light on the focusing screen to see if its edges are perfectly sharp. If not, continue to screw out the eye-lens until it is. If it cannot be made sharp by screwing it out, reverse the operation. Unless the edge of the light circle, i. e., the diaphragm of the ocular, is sharp, the resulting picture will not be satisfactory.

It should be stated that for the $\times 2$ projection ocular the bellows of the camera must be extended about 30 or 40 centimeters or the diaphragm cannot be satisfactorily focused on the screen. The $\times 4$ projection ocular can be focused with the bellows much shorter. For either projection ocular the screen distance can be extended almost indefinitely.

When the diaphragm is sharply focused on the screen, the microscope is focused, that is, first with the unaided eye then with the focusing glass. The exposure is made in the same way, as though no ocular were used (§ 349*a*), although one must have regard to the greater magnification produced by the projection ocular and increase the time accordingly; thus when the $\times 4$ ocular is used, the time should be at least doubled over that when no ocular is employed. The time will be still further increased if a color screen is used (§ 376).

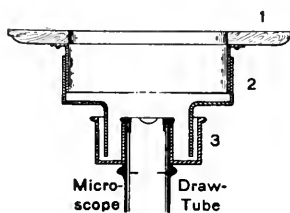

FIG. 134. LIGHT EXCLUDER FOR PHOTO-MICROGRAPHY.

(About $\frac{1}{4}$ natural size).

In this figure the different parts of the light excluder are in position for making an exposure.

1 The front board of the camera.

2 The intermediate part connecting the camera and the hollow cylinder on the upper end of the microscope draw-tube. (Compare fig. 133).

It is recommended that when the bellows have sufficient length the lower projection oculars be used, but with short bellows the higher ones.

§ 350. Determination of the magnification of the photo-micrograph. — After a successful negative has been made, it is desirable and important to know the magnification. This is easily determined by removing the object and putting in its place a stage micrometer. If the distance between two or more of the lines of the image on the focusing screen is obtained with dividers and the distance measured on one of the steel rules, the magnification is found by dividing the size of the image by the known size of the object (§ 234). If now the length of the bellows from the tube of the microscope is noted, say on a record table like that in § 358, one can get a close approximation to the power at some other time by using the same optical combination and length of bellows.

For obtaining the magnification at which negatives are made it is a great advantage to have one micrometer in half millimeters ruled with coarse lines for use with the lower powers, and one in 0.1 and 0.01 millimeters ruled with fine lines for the higher powers (fig. 80).

§ 351. Photo-micrographs at a magnification of 100 to 150 diameters. — For this, the simple arrangements given in the preceding section will answer, but the objectives must be of shorter focus, 8 to 3 mm.

§ 352. Lighting for photo-micrography with moderate and high powers. (100 to 2500 diameters). — No matter how good one's apparatus, successful photo-micrographs cannot be made unless the object to be photographed is properly illuminated. The beginner can do nothing better than to go over with the greatest care the directions for centering the condenser, for centering the source of illumination, and the discussion of the proper cone of light and lighting the whole field, as given in § 110-112. Then for each picture the photographer must take the necessary pains to light the object properly. An achromatic condenser is almost a necessity (§ 101). Whether a color screen should be used depends upon judgment and that can be attained only by experience. In the beginning one may try without a screen and with different screens and compare results.

A plan used by many skilled workers is to light the object and the field around it well and then to place a metal diaphragm of the proper size in the camera very close to the plate holder. This will insure a clean, sharp margin to the picture. This metal diaphragm must be removed while focusing the diaphragm of the projection ocular, as the diaphragm opening is smaller than the image of the ocular diaphragm.

If the young photo-micrographer will be careful to select for his first trials objects of which really good photo-micrographs have already been

made, and then persists with each one until fairly good results are attained, his progress will be far more rapid than as if poor pictures of many different things were made. He should, of course, begin with low magnifications.

§ 353. **Adjusting the objective for cover-glass.** — After the object is properly lighted, the objective, if adjustable, must be corrected for the thickness of cover. If one knows the exact thickness of the cover and the objective is marked for different thicknesses, it is easy to get the adjustment approximately correct mechanically; then the

final corrections depend on the skill and judgment of the worker. It is to be noted too that if the objective is to be used without a

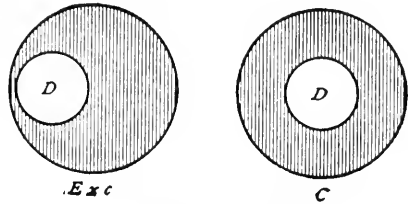

FIG. 135. VIEW OF THE BACK LENS OF THE OBJECTIVE, SHOWING THE CONDENSER OUT OF CENTER AND CENTERED.

Exc The spot of light (*D*) is to one side of the center, showing that the optic axis of the condenser is not in line with that of the microscope.

C The spot of light (*D*) is in the center, showing that the optic axis of the condenser and microscope are in line.

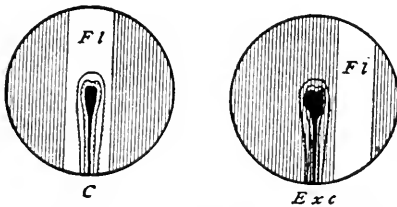

FIG. 136. FIELD OF THE MICROSCOPE SHOWING THE LIGHT IN THE CENTER AND TO ONE SIDE.

C Fl The light is in the center and illuminates the object.

Exc Fl The light is at one side of the center and does not illuminate the object. (The field is not fully lighted, as a low power is used to center the object and the light).

projection ocular the tube-length is practically extended to the focusing screen, and as the effect of lengthening the tube is the same as thickening the cover-glass, the adjusting collar must be turned to a higher number than the actual thickness of the cover calls for (see § 134).

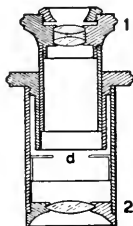

FIG. 137. PROJECTION OCULAR IN SECTION.

(About $\frac{1}{2}$ natural Size).

1 The upper or eye end of the ocular; it is composed of two convex and one concave lens and serves to project the real image formed by the objective and field lens at *d* upon the screen or photographic plate. It is movable to permit of focusing at different screen distances.

2 Field lens of the projection ocular.

d Diaphragm where the real image is formed.

§ 354. **Photographing without an ocular.**—

Proceed exactly as described for the lower power, but if the objective is adjustable make the proper adjustment for the increased tube-length (§ 134).

§ 355. **Photographing with a projection ocular.**

— Proceed as described in § 349 *b*, only in this case the objective is not to be adjusted for the extra length of bellows. If it is corrected for the ordinary ocular, the projection ocular then projects this correct image upon the focusing-screen.

§ 356. **Photo-micrographs at a magnification of 500 to 2000 diameters.**— For this the homogeneous immersion objective is employed, and as it requires a long bellows to get the higher magnification with the objective alone, it is best to use the projection oculars.

For this work the directions given in § 104-107 must be followed with great exactness. The edge of the petroleum lamp flame is sufficient to fill the field in most cases. With many objects the time required with good lamplight is not excessive; viz., 40 seconds to 3 minutes. The reason of this is that while the illumination diminishes directly as the square of the magnification, it increases with the increase in the numerical aperture, so that the illuminating power of the homogeneous immersion is great in spite of the great magnification.

For work with high powers a stronger light than the petroleum lamp is employed by those doing considerable photo-micrography. Good work may be done, however, with the petroleum lamp.

It may be well to recall the statement made in the beginning, that

the specimen to be photographed must be of special excellence for all powers. No one will doubt the truth of the statement who undertakes to make photo-micrographs at a magnification of 500 to 2000 diameters.

If one has a complete outfit with electric arc light the time required for photographing objects is much reduced, i.e., ranging from 1 to 20 seconds even with the color screen. As the light is so intense with the arc light it is necessary to soften it greatly for focusing. Several thicknesses of ground-glass placed between the lamp and the microscope will answer. These are removed before taking the negative. It is well also to have a water bath on the optical bench to absorb the radiant heat. This should be in position constantly (see fig. 111, 131).

§ 357. **Use of oculars in photo-micrography.**—There is much diversity of opinion whether or not the ordinary oculars used for observation should be used in photographing. Excellent results have been obtained with them and also without them.

When an ocular is used the eye-lens serves to project a real image of the objective, not to act as a magnifier with the eye as an ordinary observation; therefore for the best results in photography this eye-lens should be a combination which will give a correct image. For apochromatic objectives only the projection or the compensation oculars should be used, not ordinary Huygenian oculars. The projection and compensation oculars work well with the best high-angled achromatic objectives also.

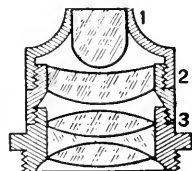

FIG. 138. ACHROMATIC SUBSTAGE CONDENSER FOR PHOTO-MICROGRAPHY.

(From Watson's Catalogue).

1, 2, 3 The three optical parts of the condenser. (Compare fig. 39 and 40, also the construction of objectives in fig. 21 *A B C* and note that the condenser is like an inverted objective.)

§ 358. Negative record in photography.

Name	No.	Location
Camera.....		Date.....
.....		Exposure.....
Objective.....		Developer.....
Ocular.....		Fixer.....
Condenser.....		Mag. \times
Diaphragm.....		Remarks.....
Object stained with.....	
Color screen.....	
Plate.....	
Light and hour.....	
.....	

PROJECTION APPARATUS FOR PHOTOGRAPHIC ENLARGEMENTS

§ 359. Enlarged prints of small negatives. — There is great advantage in making pictures of large objects at a considerable distance with a long-focus objective, so that the perspective will be correct and all levels of the object be in good focus. It is also advantageous to make pictures of microscopic objects without undue enlargement; then there is greater sharpness of the object as a whole.

If now one wishes a large print, any good negative can be used and a print obtained of almost any desired enlargement by using a photographic objective for projecting the image upon the photographic paper. This is done with projection apparatus in a dark room as follows: The management of the projection apparatus is as for drawing. The negative is placed in some kind of a holder and put in the cone of light of the main condenser where the part of it to be enlarged is fully illuminated. An erect image will be printed on the paper if the film side of the negative faces the paper exactly as for contact printing. Of course if it is desired to reverse the position it can be done by turning the film side toward the source of light.

§ 360. **Size of condenser required.** — The general law is that the diameter of the condenser must be equal to or somewhat greater than the diagonal of the negative or part of the negative to be enlarged. For example to enlarge the whole of a lantern slide negative (85×100 mm.), the condenser should have a diameter of 14 cm. For a negative 100×125 mm. the condenser should be 18 cm. in diameter; for one 125×175 mm. the condenser should be 23 cm. in diameter, and for a negative 200×250 mm. the condenser should be 35 cm. in diameter.

§ 361. **Objectives to use for enlarging.** — It is necessary to use an objective which has been corrected for photography. The ordinary projection objective gives a good visual image, but not a good photographic image. The iris diaphragm must be wide open (§ 289, 362).

In preparing for printing, which of course is done in a dark room, put some white paper in a printing frame with a clear glass in it. Hold it in the path of the beam from the projection apparatus, and either by moving a support near the apparatus, or by moving the projection apparatus, get the desired size of picture. One can determine the exact magnification by putting a lantern slide of the metric scale (fig. 104) in place of the negative and projecting its image upon the white paper in the printing frame.

§ 362. **Focusing and printing.** — Focus the image of the negative as sharply as possible. Then put over the end of the objective a cover of some kind with ruby glass in it. This will allow the light to pass in part, but it will not injure the photographic paper to be used.

Place in the printing frame some developing paper like cyco or velox. Place the printing frame in position. The image will show clearly on the paper by the red light. When the frame is in the exact position desired, remove the cap with ruby glass and make the exposure. With an arc light the time will vary from about 2 to 10 seconds, depending on the density of the negative. Cover the objective, turn off the arc lamp, and develop the print as for contact printed pictures. As shown in § 289, a mazda lamp may be used instead of an arc light for enlarging. If the rather large source of light in the 110 volt lamp is used, a diffuser of ground glass is needed

to avoid the shadows between the filaments. When a diffuser is used with the mazda or arc light the diaphragm of the objective can be closed as much as desired, but of course it then takes a much longer exposure. If now one uses a 6 volt mazda stereopticon lamp by inserting a transformer in the circuit for the alternating current or by using a storage battery for the direct current, the filament is so concentrated that the source may be treated like that of an arc light, and no diffuser used. This makes it possible to use the full opening of the objective. The candle power of the 6 volt mazda is much less than that of the arc light, but it has the advantage of requiring no attention after being once centered.

§ 363. Printing the image of an object directly on the paper. — With the apparatus set up exactly as for drawing or for printing enlargements, one can expose the developing photographic paper to the sharply focused image of the specimen. Of course this will give a negative image, all the lights and shades being reversed, but the outlines and proportions are perfect. Such pictures serve as useful a purpose as shade-correct pictures for model making and for keeping a record of one's specimens.

PHOTOGRAPHIC REPRESENTATION OF VISUAL APPEARANCES

PANCHROMATIC PHOTOGRAPHY WITH COLOR SCREENS

§ 364. Five methods of rendering objects visible. —

(1) The mounting medium and the object must have different refractive indices, then the outline of the object or of its details are margined by dark borders (§ 137, refraction images).

(2) The object or its details must have a different color from the surrounding medium or neighboring objects (color images, § 137).

(3) The object or its details must appear self-luminous, the surrounding field being dark (method of dark-ground illumination, § 117). For large objects, an illuminated clock face on a dark night is a good illustration.

(4) If reflected light is used some parts of the object must absorb the light and some parts reflect it; the different parts will then appear as light and dark.

(5) If transmitted light is used some parts of the object must be transparent or translucent and other parts opaque. The opaque parts will then appear dark and the transparent or translucent parts light.

Two, four, and five might properly be called absorption images.

§ 365. Photography is admirably adapted to represent the visual appearances of both naked eye and of microscopic objects. There is only one difficulty which is really serious, and that is in the proper representation in black and white of the various colors.

This difficulty is inherent in the sensitiveness of the eye to colors and the unlike sensitiveness of the photographic plate to the same colors. If both were equally and similarly sensitive, then the photographic representation of color in shades or tones of black and white would have the same brightness as the different colors to the eye. But the eye has its maximum sensitiveness in the green (fig. 139), while the photographic plate has almost all of its sensitiveness in the violet-blue end of the spectrum. Indeed it is sensitive to a part of the ultra violet which is wholly dark to the eye. Hence the photograph represents the brilliant red-orange-yellow-green image seen by the eye as dark, while the relatively dark violet-blue to the eye is rendered white by the photographic plate. The photographic image of colored objects is then a kind of negative of the same image to the eye. This has made the use of photography unsatisfactory where objects have color, and most objects in nature are colored more or less; and one of the greatest triumphs of microscopic science has been the differentiation of details of structure by selective staining.

From the earliest history of photography the inability to render the colors properly or in actual colors has been greatly deplored. To give the proper brightness in tones of black and white to colored objects two things had to be attained:

(1) The photographic plates which were originally sensitive only to the violet-blue end of the spectrum had to be rendered sensitive to the other colors. The first step was in getting plates sensitive to the spectrum as far as the yellow. These are the so-called Isochromatic or Orthochromatic plates. The final step was to get plates sensitive to all the colors of the spectrum, including the orange and red. These are known as Panchromatic or Spectrum plates.

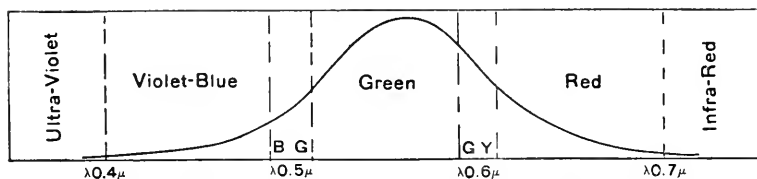

FIG. 139. SENSITIVENESS OF THE EYE TO THE SPECTRUM WITH MODERATE ILLUMINATION.

(Base Line = Wave lengths $\times 250,000$ times).

As shown in this curve the normal human eye with moderate illumination has its maximum sensitiveness at about wave length $\lambda 0.55\mu$, that is, in the green next the yellow. With very brilliant light the greatest sensitiveness is in the yellow, while with dim light it moves along well into the green. (See § 406 for designation of wave lengths in microns, etc.).

Ultra-violet Short radiation invisible to the eye. Compare the sensitiveness of the photographic plate to this radiation (fig. 140-142).

Violet-blue Radiation at the blue end of the spectrum.

Green Radiation in the middle of the spectrum.

Red Radiation at the red end of the spectrum.

Infra-red Long radiation invisible to the eye.

G Y Borderland between green and yellow.

B G Borderland between blue and green.

(2) But as all of these color-sensitive plates are more sensitive to the violet-blue than to the other colors, it is necessary to use some means

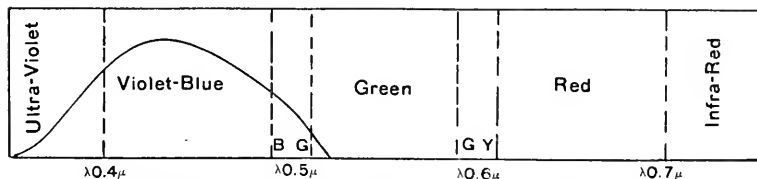

FIG. 140. NORMAL SPECTRUM SHOWING THE SENSITIVENESS OF ORDINARY PHOTOGRAPHIC PLATES.

(After Mees, and magnified as in fig. 139).

As shown in this curve, the ordinary photographic plate is sensitive only in the blue end of the spectrum including the ultra-violet, the maximum sensitiveness being at about wave length $\lambda 0.45\mu$. It is insensitive to all wave lengths longer than about $\lambda 0.52\mu$. (Compare with fig. 139, 141-142).

for reducing or blocking out part of the violet-blue light without interfering with the action of the other colors (§ 367). For gaining

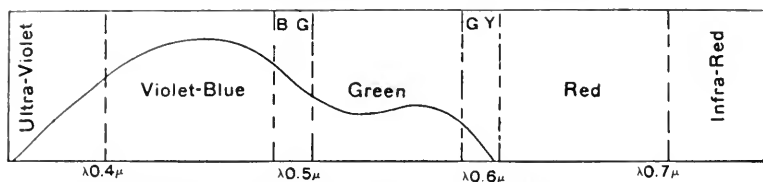

FIG. 141. NORMAL SPECTRUM SHOWING THE SENSITIVENESS OF ORTHOCHROMATIC OR ISOCHROMATIC PLATES.

(After Mees; magnification as in fig. 139).

These plates have practically the same sensitiveness as the ordinary plates except that the sensitiveness is continued through the green and yellow. (Compare fig. 139, 140 and 142.)

contrast effects it was necessary to devise means for blocking out special parts of the spectrum (§ 368). These selecting media are known as Color Screens or Ray Filters.

COLOR SCREENS OR RAY FILTERS

§ 366. **Color screens or ray filters.**—These are transparent, colored bodies which select the wave lengths of light which they transmit and absorb the other waves, or they diminish more or less some of the wave lengths and transmit the others with very slight loss. The color of such a screen to the eye will be determined by the

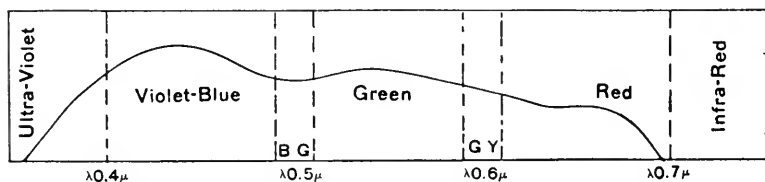

FIG. 142. NORMAL SPECTRUM SHOWING THE SENSITIVENESS OF PANCHROMATIC PLATES.

(After Mees; magnification as in fig. 139).

Panchromatic plates have the maximum sensitiveness still in the violet-blue, but it is extended to include the red. (Compare fig. 139-141).

light which it transmits in the greatest quantity. For example, if the violet-blue light is absorbed the remaining light will appear

yellow, while if green and red are absorbed the transmitted light will appear blue; if violet-blue and green are absorbed the light will appear red, and if violet-blue and red are largely absorbed the remaining light will appear green. .

§ 367. **Compensating ray filters.** — These are filters or screens which aid the panchromatic photographic plate in giving a black and white picture of colored objects which shall correspond in brightness to the different colors as seen by the eye.

As all photographic plates, even the panchromatic ones, are more sensitive to the violet-blue than to the other colors of the spectrum (fig. 142), the effect of the violet-blue must be reduced, hence yellow screens must be used to do this and compensate for the smaller sensitiveness of the plate for the other parts of the spectrum.

Fortunately the great photographic manufacturers have made a study of the principles of color screens as well as of their plates, and they supply workers with data showing what wave lengths of light their different plates are sensitive to, and the wave lengths absorbed wholly or in part by their ray filters. They also give advice from abundant experience as to the proper combination of plate and color screen to get the best effect in photographing a great variety of colored objects. By using this information, and profiting by experience, one can learn to photograph almost any object successfully.

§ 368. **Contrast ray filters.** — These are filters or screens by the aid of which strong contrasts in black and white are given to various colored objects or their details. As given in the general statement of the basis for visibility of objects and their details, refraction and opacity are of prime importance for securing sharp outlines. Color images are also of the greatest advantage in differentiating the details of microscopic structure, but as color does not appear in the ordinary photograph the differentiation of colored objects must be secured by producing shades of light and dark up to complete blackness in some cases. For example, in some microscopic specimens important details may be stained violet or blue. To the eye these violet or blue objects stand out with great clearness. In the photograph, on the other hand, without special help from a color screen, they are wholly lost or are so faint that they can hardly be seen. To make such details stand

out in shades of black, a yellow color screen absorbing violet-blue and allowing the other colors to pass is used with a plate sensitive to the other colors to be photographed. A picture is thus obtained which shows the violet-blue objects in black and the other details in various shades.

A contrast color screen does not of course give correct brightness, but the purpose in using it is to bring out in the most striking manner the form of certain structures. The general law is: For contrast effects, use a color screen which absorbs the light transmitted normally by the colored object, but allows the other colors to pass.

§ 369. **Refraction and opacity and color screens.** — It should not be forgotten in using color screens and color-sensitive plates that refraction and opacity exert their full effect in producing the final result. The color screen acts only to suppress or lessen certain definite wave lengths. Refraction and opacity tend to suppress all wave lengths in certain limited borders or definite areas. Hence any stain like hematoxylin which tends to make an object more opaque to all parts of the spectrum will increase the contrast even if no color screen is used.

§ 370. **Lessening contrast.** — With some specimens it is necessary to lessen contrast in order to bring out details of structure. One of the striking examples frequently referred to is whalebone. A microscopic section of this has a reddish appearance by transmitted light. If now a blue screen is used with a panchromatic plate the greatest possible contrast is obtained, and the object loses all detail in the photograph. If on the other hand a red screen is used the photograph shows good detail and the general appearance is like that seen by the eye in looking into the microscope.

The general law is: When the contrast is too great use a color screen of the same color as the object, and of course a plate must be used sensitive to that color.

§ 371. **Use of the microspectroscope in photo-micrography.** — If one studies his specimens with the microspectroscope and makes sure exactly what light is transmitted by them, it will be possible to judge with intelligence what plate and what color screen to use to bring out in the most satisfactory manner their structural appearances.

Fortunately the manufacturers furnish the information concerning their plates and the color filters, so that labor is spared the individual worker. It might be worth while for him to check up the color screens occasionally to make sure that they have not deteriorated.

§ 372. **Time of exposure for photo-micrographs.** — This varies from the fraction of a second to several minutes, depending on four factors:

(1) The nature and intensity of the light.

(2) The magnification of the microscope. The higher the magnification the longer must be the exposure.

(3) The transparency of the specimen. The more transparent the shorter the exposures.

(4) The thicker or deeper the color of the ray filter the longer must be the exposure.

LIGHT FOR PHOTO-MICROGRAPHY

§ 373. **Daylight.** — This has served for some of the best photographs which have ever been made. If it is not available, artificial daylight obtained by using daylight glass forms a very good substitute (§ 97).

§ 374. **Artificial lights.** — As compared with daylight all ordinary forms of artificial light have a great excess in the red end of the spectrum (see fig. 36, comparing the mazda and daylight). This excess in the red end has the advantage that it partly compensates for the excessive sensitiveness of the photographic plate for violet-blue light. For many objects a kerosene lamp is excellent for photographing by, as it serves for both light and color screen.

§ 375. **Mutual adaptation of color screen and light.** — As the color screen is for a very definite purpose in absorbing certain parts of the light it follows that the character of the light and that of the color screen must be mutually adapted. For example it is self-evident that the same color screen for a given preparation would not serve for both daylight and the light from a mazda lamp (see fig. 36). So also the same color screen would not be successful if used both for the mazda light and for the light of a kerosene flame.

For the most successful use of color screens and different light sources one should have curves of the intensity of the light in different parts of the visible spectrum like that for the mazda lamp and sunlight (fig. 36). Then one should know the absorption by each color filter for each kind of light. Knowing these facts and the absorbing and transmitting qualities of his specimens, and the sensitiveness of the photographic plates used one could make intelligent selections and reasonably expect good results.

§ 376. **Exposure with color screens.** — The color screen naturally increases the time of exposure. It depends on the color and density of the screen. In general the exposure is increased from 2 to 5 times. The increase necessary is usually given by the manufacturers, therefore each individual worker does not have to find out by experiment. There is plenty of opportunity for the use of his judgment with the different qualities of his specimens (see also § 372).

§ 377. **Developers.** — It is best to use the developers recommended by the manufacturers of the plates used. The experts employed by the manufacturers have found the best means for developing the plates, and it is safe to follow their advice. One usually has a choice of developers; and as a general statement it should be said that the beginner would be wise to prefer a slow developer, for it allows a greater latitude than a rapid developer. In general a developer containing much bromide works slowly and gives very strong contrasts. Sometimes this is desirable, but often it is better to get the soft effects that come with a small amount of bromide. If one studies the little manuals sent out by the manufacturers there will be found formulæ which give the various effects desired. (See collateral reading suggested at the end of the chapter).

§ 378. **Light to develop by.** — The light which can be used in the dark room depends upon the sensitiveness of the plates or the printing paper used. The more sensitive the plates or paper the less light. Furthermore the sensitiveness to the different wave lengths is also important to consider. If the plates are sensitive only to the violet-blue of the spectrum, the dark room can be quite brightly lighted with red light with entire safety. If isochromatic or orthochromatic plates are used they are sensitive to the spectrum up to and including

yellow, and hence the dark-room light must exclude those, or be red only.

For panchromatic plates which are sensitive to all wave lengths the only safe method is to develop in total darkness for any light will fog the plate if it acts sufficiently upon it. Sometimes very dark green is used, for the eye is most sensitive to green if the light is very dim, although for bright light the eye is most sensitive to yellow. But to be able to see clearly enough to determine the stage of development by the green light dim enough to be safe one must be in the

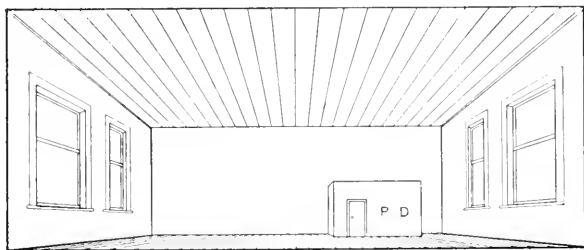

FIG. 143. DARK ROOM FOR PHOTOGRAPHY AND DRAWING IN A LARGE ROOM.
(From Optic Projection).

dark room for half an hour or more. The total darkness method is safest. One learns rather quickly to work in total darkness, and the time during which development goes on can be determined by counting seconds or a signal clock ringing minutes or an alarm clock which can be set at the beginning for the estimated time can be used. Or finally, one can develop in a tray which is covered so that no light can reach the plate; then the ordinary dark-room light can be turned on from time to time to see when the estimated period for development has been reached.

It is far safer to use too little light for developing rather than too much. For ordinary or for isochromatic plates only a brief glance occasionally is all that is needed. If one holds the plate in the dark-room light during the whole development or for a considerable time there is almost always a thin veil of fog which lessens the crispness of the picture.

The wisdom of the advice to develop isochromatic or ordinary plates with as small an exposure to the dark-room light as possible can be demonstrated by the beginner in the following experiment which he is advised to try.

Put an isochromatic or orthochromatic plate in the plate holder. Pull out the dark slide till one or two centimeters of the film is exposed, then leave this for half a minute, close to the developing-room light. Pull out the slide another centimeter or two and expose again to the dark-room light. Continue till the entire plate has been exposed. The last segment will have an exposure of half a minute, next to the last a whole minute, and so on. Now develop the picture in the ordinary way and the chances are that the plate will show very marked light effects, and the different segments in proportion to the time they were exposed to the dark-room light.

§ 379. **Time development.** — Assuming that the correct plate and color screen is used, careful experiments made in the scientific laboratories of the large plate manufacturers have shown that the best method of developing photographic negatives is that of developing a definite time at a definite temperature of the developer. The time and temperature must of course be determined for the special plate and composition of developer to be used. The variable then is the exposure of the plate. A perfectly timed plate will contain all the desired detail in the shadows and just sufficient density in the high lights so that the print will be sufficiently white. The deepest shadows in such a negative will be almost perfectly transparent.

A convenient and safe method of developing plates by the time method without having the room absolutely dark and without exposing the plate to any harmful light, is the following: The dark-room safelight is directed away from the developing tray and a shield put in position to further screen it. An alarm or other large-faced clock, with second hand, is put close to the safelight. This light may then be very dim and still illuminate the clock face sufficiently. If using isochromatic or orthochromatic plates the red safelight is good, but if panchromatic or spectrum plates are used the green safelight is better. The exceedingly minute amount of light reaching the

plate from the safelight as here recommended can cause no damage (Henry Phelps Gage, Optical Department, Corning Glass Works).

§ 380. **Choice of plates and color screens.** — The hints given in the little manuals sent out by the manufacturers on request by their patrons give excellent hints for the selection of plates and color screens for a wide variety of objects. The beginner cannot do better than to follow those suggestions faithfully, until his own experience enables him to supplement those suggestions. Finally, of course, one wishes to be able to use his own judgment.

In general, if any color is present in the object to be photographed one will have better success with isochromatic or orthochromatic plates, which are sensitive to violet-blue, green, and yellow, than with the ordinary plates, which are only sensitive to the violet-blue of the spectrum (fig. 140-141). If the colors involved contain orange and red the isochromatic plates are not adequate, and one must then use panchromatic or spectrum plates, sensitive to all wave lengths (fig. 142).

For the color screen to employ, remember that color screens are not of real use for ordinary plates sensitive only to violet and blue. For isochromatic plates yellow color screens are very helpful for reducing the excessive effect of the violet and blue (§ 367) or for cutting them out altogether in getting contrast effects (§ 368). The same is true for panchromatic plates, only here a wider range of color screens can be used to get any desired contrast or compensating effect.

COLOR PHOTOGRAPHY

§ 381. **Photographs in natural colors.** — This has been the aim of experts in photography ever since its first invention. Lately methods have been devised by which surprisingly true color photographs have been produced. These color pictures are better adapted to large objects than to those with fine details such as are observed with the microscope. Still, many objects are fairly well represented in photo-micrographs.

The author's experience in color photography has been limited to the "Autochrome Process" (colored starch grain process). The directions in the small manual sent out with the plates are very clear,

and any one familiar with the ordinary photographic processes can succeed in color photography. It may be said in passing that the pictures taken by this process are transparencies and must be looked at as such to bring out the colors. Furthermore, as colors are truly rendered only in daylight or by artificial daylight these transparencies must be illuminated by natural or artificial daylight for a true rendering of the color.

While these pictures cannot be used as negatives to give paper prints in colors, they can be used as colored pictures to get the proper negatives for printing by the three-color process, so that with a good autochrome transparency, colored pictures for books and magazines can be produced without any hand being taken in the process by an artist; and for many things the transparency gives a truth and delicacy in coloring not attainable by the artist's brush.

COLLATERAL READING FOR CHAPTER VII

Optic Projection, by S. H. & H. P. Gage.

The Wratten Booklets on Photographic Plates and Color Filters.

The Photography of Colored Objects, by C. E. Kenneth Mees.

Photo-micrography. Published by the Eastman Kodak Co.

Seed Plates, formulæ and directions. Eastman Kodak Co.

Furnished by the G. Cramer Dry Plate Company:

Cramer's Manual on Negative Making and Formulas.

Isochromatic Landscape Photography.

The Photographing of Color Contrasts.

Dry Plates and Filters for Trichromatic Work,

Photo-micrographic and Spectrographic Color Filters.

These brochures are naturally very recent and give the meat of the information at present available on the kind of photographic plates available and the proper color filters to use with them to produce the best effects with different colored objects in gross photography and in photo-micrography.

For the sensitiveness of the human eye to the different parts of the spectrum see: Herbert E. Ives, *Philosophical Magazine*, Vol. XXIV, 6th ser. Dec. 1912, pp. 853-863; P. G. Nutting, *Transactions of the Illuminating Engineering Society*, 1914, pp. 633-642.

CHAPTER VIII

MICRO-SPECTROSCOPE AND POLARISCOPE

§ 390. Apparatus and material for Chapter VIII.

1. Compound microscope.
2. Micro-spectroscope (§ 392, 400).
3. Watch-glasses and shell vials, slides, and covers (§ 410).
4. Various substances for examination (as blood and ammonium sulphide, permanganate of potash, chlorophyll, some colored fruits, etc. (§ 412-419)).
5. Micropolarizer (§ 421).
6. Selenite plate (§ 431).
7. Various doubly refracting objects, crystals, textile fibers, starch, section of bone (§ 430).

§ 391. **Visible and invisible radiation.** — From any primary source of light energy like the sun, the electric arc, etc., not only is the energy which to the eye is appreciated as light, but wave lengths of energy both longer and shorter than those affecting the eye are given off. As shown in fig. 144 the segment of the energy spectrum which is visible to the eye is exceedingly limited, being included between about $\lambda 0.4\mu$ and $\lambda 0.7\mu$. Under special illumination, waves shorter than $\lambda 0.4\mu$ and longer than $\lambda 0.7\mu$ can be seen, but the extension into the infra-red or the ultra-violet is very slight, and not used for ordinary visual purposes.

It is fortunate for optical instruments that the visible spectrum is so limited. Indeed, if the visible spectrum were even more limited it would be easier to obtain perfect images, for the aberrations arising from the different wave lengths would be so much the less.

The spectroscope has for its object the giving of information concerning the visible spectrum, and it has proved of very great help indeed. It should not be forgotten, however, that the color effects produced by the spectroscope are not the only ones and in some ways not the most important. What it really does is to divide up the wave lengths in groups, and in absorption phenomena the important thing is that some wave lengths are not present or are cut out by the absorbing medium and hence there are present dark bands in the

spectrum (absorption bands). These absorption bands could be seen and their significance appreciated by a person wholly color blind — and there is occasionally such a person.

§ 392. A **micro-spectroscope**, spectroscopic or spectral ocular, is a direct-vision spectroscope in connection with a microscope ocular. It consists of a direct-vision spectroscope prism of the Amici pattern, and of considerable dispersion, placed over the ocular of the microscope.

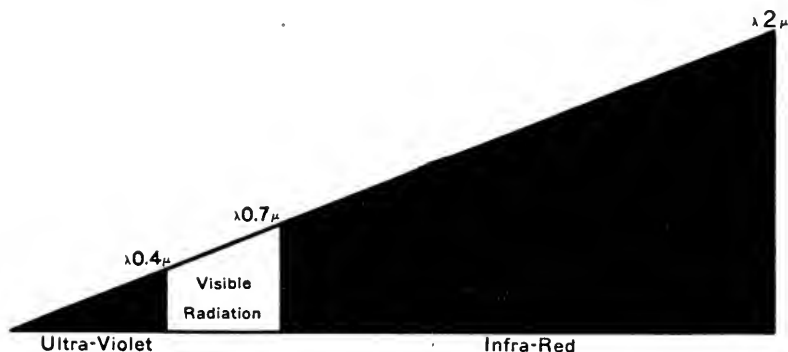

FIG. 144. NORMAL SPECTRUM SHOWING VISIBLE AND INVISIBLE RADIATION.
(Magnified 20,000 times vertically and 50,000 times horizontally).
(From Optic Projection).

As shown in white, the useful radiation for vision lies between $\lambda 0.4\mu$ and $\lambda 0.7\mu$. Under favorable conditions the eye can see shorter and longer radiations.

Ultra-violet Radiation having waves shorter than $\lambda 0.4\mu$; (Black).

Infra-red Radiation with waves longer than $\lambda 0.7\mu$. Radiation up to a wave length of $\lambda 2\mu$ is here shown in black.

This direct vision or Amici prism consists of a single triangular prism of heavy flint glass in the middle and one of crown glass on each side, the edges of the crown glass prisms pointing toward the base of the flint glass prism, i.e., the edges of the crown and flint glass prisms point in opposite directions. The flint glass prism serves to give the dispersion or separation into colors, while the crown-glass prisms serve to make the emergent rays approximately parallel with the incident rays, so that one looks directly into the prism along the axis of the microscope.

The Amici prism is in a special tube which is hinged to the ocular and held in position by a spring. It may be swung free of the ocular. In connection with the ocular is the slit mechanism and a prism for reflecting horizontal rays vertically for the purpose of obtaining a comparison spectrum (§ 404). Finally, near the top is a lateral tube with mirror for the purpose of projecting an Angström scale of wave lengths upon the spectrum (§ 405, fig. 145, 148).

In accordance with the above statements the dispersion or separation into colors is given by the flint-glass prism or prisms and following the general law that the waves of shortest length, blue, etc., will be bent most, the colors have the position indicated in fig. 139-142, 146, 149. But if one looks into the direct vision spectroscopy or holds the eye close to the single prism (fig. 145), the colors will appear reversed as if the red were more bent. The explanation of this is shown in fig. 145, 2, where it can be readily seen that if the eye is placed at E, close to the prism, the different colored rays appear in the direction from which they reach the eye and consequently are crossed in being projected into the field of vision and the real position is inverted. The same is true in looking into the micro-spectroscope. The actual position of the different colors may be determined by placing some ground-glass or some of the lens-paper near the prism and observing with the eye at the distance of distinct vision.

§ 392a. The author wishes to acknowledge the aid rendered by Professor E. L. Nichols in giving the explanation offered in § 392.

VARIOUS KINDS OF SPECTRA

By a spectrum is meant the colored bands appearing when the light traverses a dispersing prism or a diffraction grating, or is affected in any way to separate the different wave lengths of light into groups. When daylight or some good artificial light is thus dispersed one gets the appearance so familiar in the rainbow.

§ 393. **Continuous spectrum.**—In case a good artificial light, as the electric light, is used, the various rainbow or spectral colors merge gradually into one another in passing from end to end of the spectrum. There are no breaks or gaps.

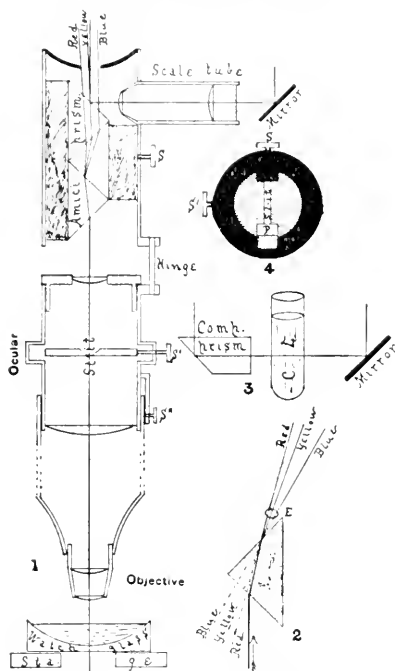

FIG. 145. DIAGRAM OF A DIRECT-VISION MICRO-SPECTROSCOPE.

1 The spectroscope is shown in position on the microscope, the tube of the microscope being much shortened to save space.

Stage, the stage of the microscope on which is a watch glass with sloping sides.

Objective The objective of the microscope.

S S' S'' Screws for clamping the apparatus and for changing the position of parts.

Slit The slit of the spectroscope between the ocular lenses in the position of the ocular diaphragm.

Hinge The hinge on which the prism can be turned off the ocular.

Amici prism The direct-vision prism composed of a middle flint and two crown-glass prisms.

Red Yellow Blue Arrangement of the colors as they emerge from the prism.

Scale tube and Mirror The mirror to throw light into the scale tube and project an image of the Angström scale into the field.

2 *Prism* showing that with the eye close to the prism the colors seem reversed from the position actually occupied.

3 *Comp. prism* The prism introduced under the slit and serving to reflect up into the microscope a spectrum for comparison with that extending along the axis of the microscope from below. *C.L.* Liquid in the tube whose spectrum is to be compared with that of the liquid in the watch glass on the stage of the microscope.

4 The slit mechanism and comparison prism (*p*).

S S' S'' Set screws for changing the width and length of the slit.

§ 394. **Line spectrum.** — If a gas is made incandescent, the spectrum it produces consists, not of the various rainbow colors, but of sharp, narrow, bright lines, the color depending on the substance.

All the rest of the spectrum is dark. These line spectra are very strikingly shown by metallic vapors heated to incandescence, e.g.

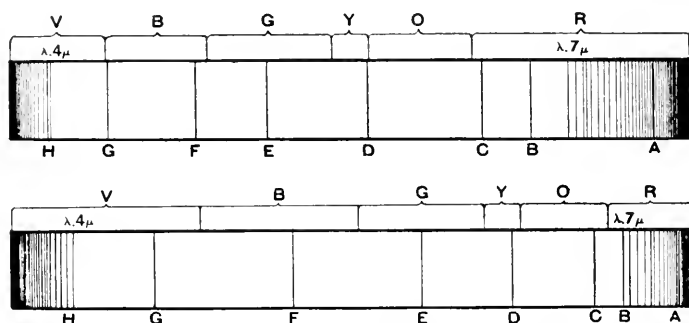

FIG. 146-147. A NORMAL AND A PRISMATIC SPECTRUM OF DAYLIGHT.

FIG. 146. NORMAL SPECTRUM OF DAYLIGHT SHOWING THE SEGMENTS OF COLOR, *V B G Y O R*, AND THE DARK LINES, *H G F E D C B A*.

In the normal spectrum produced by a grating the dispersion is directly proportional to the wave length of the light; hence the red is a broad band and the violet-blue narrow. (Compare the prismatic spectrum where the red is narrow and the blue broad.)

0.4μ 0.7μ , the wave lengths between which the radiation is visible (see fig. 144).

FIG. 147. PRISMATIC SPECTRUM OF DAYLIGHT.

As glass does not disperse the different wave lengths in direct proportion to their length, the width of the bands of color are strikingly unlike those in the normal spectrum, the blue-violet being wide and the red very narrow.

sodium. These spectra are usually obtained by heating some salt of the substance (see § 405).

§ 395. **Absorption spectrum.** — By this is meant a spectrum in which there are dark lines or bands in the spectrum. The most striking and interesting of the absorption spectra is the Solar Spectrum, or spectrum of sunlight. If this is examined by a good spectroscope it will be found to be crossed by dark lines, the appearance being as if one were to draw pen marks across a continuous spectrum

at various levels, sometimes apparently between the colors and sometimes in the midst of a color. These are the so-called Fraunhofer lines. Some of the principal ones have been lettered with Roman capitals, A, B, C, D, E, F, G, H, commencing at the red end. The meaning of these lines was for a long time unknown, but it is now known that they correspond with the bright lines of a line spectrum. For example, if sodium is put in the flame of a spirit or Bunsen lamp it will vaporize and become luminous. If this light is examined there will be seen one or two bright yellow bands corresponding in position with D of the solar spectrum (fig. 146, 148). If now the spirit-lamp flame, colored by the incandescent sodium, is placed in the path of the electric light, and it is examined as before, there will be a continuous spectrum, except for dark lines in place of the bright sodium lines. That is, the comparatively cool yellow light of the spirit-lamps cuts off or absorbs the intensely hot yellow light of the electric light; and although the spirit flame sends a yellow light to the spectroscope it is so faint in comparison with the electric light that the sodium lines appear dark. It is believed that in the sun's atmosphere there are incandescent metal vapors (sodium, iron, etc.), but that they are so cool in comparison with the rays of their wave length in the sun that the cooler light of the incandescent metallic vapors absorbs the light of corresponding wave length, and is, like the spirit-lamp flame, unable to make up the loss, and therefore the dark lines are present.

§ 396. **Absorption spectra from colored substances.** — While the solar spectrum is an absorption spectrum, the term is more commonly applied to the spectra obtained with light which has passed through or has been reflected from colored objects which are not self-luminous.

It is the special purpose of the micro-spectroscope to investigate the spectra of colored objects which are not self-luminous, i.e., blood and other liquids, various minerals, as monazite, etc. The spectra obtained by examining the light reflected from these colored bodies or transmitted through them possess, like the solar spectrum, dark lines or bands, but the bands are usually much wider and less sharply defined. Their number and position depend on the substance or its

constitution (fig. 148), and their width, in part, upon the thickness of the body. With some colored bodies, no definite bands are present. The spectrum is simply restricted at one or both ends and various of the other colors are considerably lessened in intensity. This is true of many colored fruits.

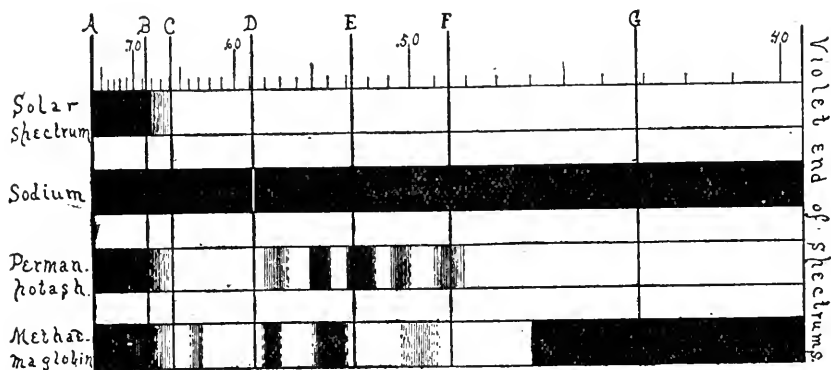

FIG. 148. SPECTRA TO SHOW DIFFERENT KINDS OF ABSORPTION BANDS.

Solar Spectrum The spectrum of daylight showing the dark, fixed lines (Fraunhofer lines) *A B C D E F G*, and the wave lengths in microns, .70, .60, .50, .40.

Sodium The spectrum of incandescent sodium. With this spectrocope it is a single bright yellow band (*D*) at about $\lambda 0.59\mu$, all the rest of the spectrum being dark.

Perman. potash The spectrum of a solution of permanganate of potash and has five absorption bands, two being especially dark and sharply outlined.

Methæmoglobin The spectrum of methæmoglobin with several absorption bands, the two in the yellow-green being darkest. The blue end of the spectrum is also greatly shortened.

These spectra have the blue end at the right instead of at the left (compare fig. 144, 146-147).

§ 397. **Angström and Stoke's law of absorption spectra.** — The waves of light absorbed by a body when light is transmitted through some of its substance are precisely the waves radiated from it when it becomes self-luminous. For example, a piece of glass that is yellow when cool gives out blue light when it is hot enough to be self-luminous. Sodium vapor absorbs two bands of yellow light (*D* lines); but when light is not sent through it, but itself is luminous

and examined as a source of light, its spectrum gives bright sodium lines, all the rest of the spectrum being dark (fig. 148).

§ 398. **Law of color.** — The light reaching the eye from a colored solid, liquid, or gaseous body lighted with white light will be that due to white light less the light waves that have been absorbed by the colored body. Or in other words, it will be due to the wave lengths of light that finally reach the eye from the object. For example, a thin layer of blood under the microscope will appear yellowish green, but a thick layer will appear pure red. If now these two layers are examined with a micro-spectroscope, the thin layer will show all colors, but the red end will be slightly, and the blue end considerably, restricted, and some of the colors will appear considerably lessened in intensity. Finally, there may appear two shadow-like bands, or, if the layer is thick enough, two well-defined dark bands in the green (§ 413).

If the thick layer is examined in the same way, the spectrum will show only red with a little orange light, all the rest being absorbed. Thus the spectroscope shows which colors remain, in part or wholly, and it is the mixture of this remaining or unabsorbed light that gives color to the object.

§ 399. **Complementary spectra.** — While it is believed that Angström's law (§ 398) is correct, there are many bodies on which it cannot be tested, as they change in chemical or molecular constitution before reaching a sufficiently high temperature to become luminous. There are compounds, however, like those of didymium, erbium, and terbium, which do not change with the heat necessary to render them luminous, and with them the incandescent and absorption spectra are mutually complementary, the one presenting bright lines where the other presents dark ones (Daniell).

ADJUSTING THE MICRO-SPECTROSCOPE

§ 400. **The micro-spectroscope,** or spectroscopic ocular, is put in the place of the ordinary ocular in the microscope, and clamped to the top of the tube by means of a side screw for the purpose.

§ 401. **Adjustment of the slit.** — In place of the ordinary diaphragm with circular opening, the spectral ocular has a diaphragm

composed of two movable knife edges by which a slit-like opening of greater or less width and length may be obtained at will by the use of screws for the purpose. To adjust the slit, depress the lever holding the prism-tube in position over the ocular, and swing the prism aside. One can then look into the ocular. The lateral screw should be used, and the knife edges approached till they appear about half a millimeter apart. If now the Amici prism is put back in place and the microscope well lighted, one will see a spectrum by looking into the upper end of the spectroscop. If the slit is too wide, the colors will overlap in the middle of the spectrum and be pure only at the red and blue ends; and the Fraunhofer or other bands in the spectrum will be faint or invisible. Dust on the edges of the slit gives the appearance of longitudinal streaks on the spectrum.

§ 402. **Mutual arrangement of slit and prism.** — In order that the spectrum may appear as if made up of colored bands going directly across the long axis of the spectrum, the slit must be parallel with the refracting edge of the prism. If the slit and prism are not thus mutually arranged, the colored bands will appear oblique, and the whole spectrum may be greatly narrowed. If the colored bands are oblique grasp the prism tube and slowly rotate it to the right or to the left until the various colored bands extend directly across the spectrum.

§ 403. **Focusing the slit.** — In order that the lines or bands in the spectrum shall be sharply defined, the eye-lens of the ocular should be accurately focused on the slit. The eye-lens is movable, and when the prism is swung aside it is very easy to focus the slit as one focused for the ocular micrometer (§ 240). If one now uses daylight there will be seen in the spectrum the dark Fraunhofer lines (fig. 146, 148).

To show the necessity of focusing the slit, move the eye-lens down or up as far as possible, and the Fraunhofer lines cannot be seen. While looking into the spectroscop move the ocular lens up or down, and when it is focused the Fraunhofer lines will reappear. As the different colors of the spectrum have different wave lengths, it is necessary to focus the slit for each color if the sharpest possible pictures are desired.

It will be found that the eye-lens of the ocular must be farther from

the slit for the sharpest focus of the red end than for the sharpest focus of the lines at the blue end. This is because the wave length of the red is markedly greater than for blue light (fig. 144).

Longitudinal dark lines on the spectrum may be due to irregularity of the slit or to the presence of dust. They are most troublesome with a very narrow slit.

§ 404. **Comparison or double spectrum.** — In order to compare the spectra of two different substances it is desirable to be able to examine their spectra side by side. This is provided for in the better forms of micro-spectroscopes by a prism just below the slit, so placed that the light entering it from a mirror at the side of the drum shall be totally reflected in a vertical direction, and thus parallel with the rays from the microscope. The two spectra will be side by side, with a narrow dark line separating them. If now the slit is well focused and daylight be sent through the microscope and into the side to the reflecting or comparison prism, the colored bands and the Fraunhofer dark lines will appear directly continuous across the two spectra. The prism for the comparison spectrum is movable and may be thrown entirely out of the field if desired. When it is to be used, it is moved about halfway across the field so that the two spectra shall have about the same width.

§ 405. **Scale of wave lengths.** — In the Abbe micro-spectroscope the scale is in a separate tube near the top of the prism and at right angles to the prism-tube. A special mirror serves to light the scale, which is projected upon the spectrum by a lens in the scale-tube. This scale is of the Angström form, and the wave lengths of any part of the spectrum may be read off directly, after the scale is once set in the proper position, that is, when it is set so that any given wave length on the scale is opposite the part of the spectrum known by previous investigation to have that particular wave length. The point most often selected for setting the scale is opposite the sodium line, where the wave length is, according to Angström, 0.5892μ . In adjusting the scale, one may focus very sharply the dark sodium line of the solar spectrum and set the scale so that the number 0.589 is opposite the sodium or D line, or a method that is frequently used and serves to illustrate § 394-395, is to sprinkle some salt of sodium

(carbonate of sodium is good) in a Bunsen or alcohol flame and to examine this flame. If this is done in a darkened place with a spectroscopic, a narrow bright band will be seen in the yellow part of the spectrum. If now ordinary daylight is sent through the comparison prism, the bright line of the sodium will be seen to be directly continuous with the dark line at D in the solar spectrum (fig. 148). By reflecting light into the scale-tube the image of the scale will appear on the spectrum, and by a screw just under the scale-tube, but within the prism-tube, the proper point on the scale (0.589μ) can be brought opposite the sodium band. All the scale will then give the wave lengths directly. Sometimes the scale is oblique to the spectrum. This may be remedied by turning the prism-tube slightly one way or the other. It may be due to the wrong position of the scale itself. If so, grasp the milled ring at the distal end of the scale-tube and, while looking into the spectroscopic, rotate the tube until the lines of the scale are parallel with the Fraunhofer lines. It is necessary in adjusting the scale to be sure that the larger number, 0.70, is at the red end of the spectrum.

The numbers on the scale should be very clearly defined. If they do not so appear, the scale-tube must be focused by grasping the outer tube of the scale-tube and moving it toward or from the prism-tube until the scale is distinct. In focusing the scale, grasp the outer scale-tube with one hand and the prism-tube with the other, and push or pull in opposite directions. In this way one will be less liable to injure the spectroscopic.

§ 406. **Designation of wave length.** — Wave lengths of light are designated by the Greek letter λ , followed by the number indicating the wave length in some fraction of a meter. In this work the micron is taken as the unit as with other microscopical measurements (§246). Various units are employed, as the one hundred thousandth of a millimeter, millionths or ten millionths of a millimeter. If these smaller units are taken, the wave lengths will be indicated either as a decimal fraction of a millimeter or as whole numbers. Thus, according to Angström, the wave length of sodium light is 5892 tenthmeters or Angström units, or 5892 ten millionths mm., or 589.2 millionths mm., or 58.92 one hundred thousandths, or 0.5892 one

thousandth mm., or 0.5892μ . The last would be indicated thus $\lambda D = 0.5892\mu$.

§ 407. **Lighting for the micro-spectroscope.** — For opaque objects a strong light should be thrown on them either with a concave mirror or condensing lens. For transparent objects, the amount of the substance and the depth of the color must be considered. As a general rule it is well to use plenty of light, as that from a substage condenser with a large opening in the diaphragm or with the diaphragm entirely open. For very small objects and thin layers of liquids it may be better to use less light. One must try both methods in a given case, and learn by experience.

The direct and the comparison spectra should be about equally illuminated. One can manage this by putting the object requiring the greater amount of illumination on the stage of the microscope. In lighting it is found in general that for red or yellow objects, lamp-light gives very satisfactory results. For the examination of blood and blood crystals, the light from a petroleum lamp is excellent. For objects with much blue or violet, daylight or artificial daylight is best (§ 92).

Furthermore, one should be on his guard against confusing the ordinary absorption bands with the Fraunhofer lines when daylight is used. With lamplight the Fraunhofer lines are absent and, therefore, not a source of possible confusion.

§ 408. **Objective to use with the micro-spectroscope.** — If the material is of considerable bulk, a low objective (16 to 50 mm.) is to be preferred. This depends on the nature of the object under examination, however. In case of individual crystals one should use sufficient magnification to make the real image of the crystal entirely fill the width of the slit. The length of the slit may then be regulated by the screw on the side of the drum, and also by the comparison prism. If the object does not fill the whole slit the white light entering the spectroscope with the light from the object might obscure the absorption bands.

In using high objectives with the micro-spectroscope one must very carefully regulate the light (Ch. II) and sometimes shade the object.

§ 409. **Focusing the objective.** — For focusing the objective the prism-tube is swung aside, and then the slit made wide by turning the adjustable screw at the side. If the slit is open one can see objects when the microscope is focused as with an ordinary ocular. After an object is focused, it may be put exactly in position to fill the slit of the spectroscope, then the knife edges are brought together till the slit is of the right width; if the slit is then too long it may be shortened by using one of the mechanism screws on the side, or if that is not sufficient, by bringing the comparison prism farther over the field. If one now replaces the Amici prism and looks into the microscope, the spectrum is liable to have longitudinal shimmering lines. To get rid of these focus up or down a little so that the microscope will be slightly out of focus.

§ 410. **Amount of material necessary for absorption spectra and its proper manipulation.** — The amount of material necessary to give an absorption spectrum varies greatly with different substances, and can be determined only by trial. If a transparent solid is under investigation it is well to have it in the form of a wedge, then successive thicknesses can be brought under the microscope. If a liquid substance is being examined, a watch glass with sloping sides forms an excellent vessel to contain it, then successive thicknesses of the liquid can be brought into the field, as with the wedge-shaped solid. Frequently only a very weak solution is obtainable; in this case it can be placed in a homœopathic vial, or in some glass tubing sealed at the end, then one can look lengthwise through the liquid and get the effect of a more concentrated solution. For minute bodies like crystals or blood corpuscles, one may proceed as described in the previous section. See also § 420.

MICRO-SPECTROSCOPE EXPERIMENTS

§ 411. Put the micro-spectroscope in position, arrange the slit and the Amici prism so that the spectrum will show the various spectral colors going directly across it (§ 402), and focus the slit. This may be done either by swinging the prism-tube aside and proceeding as for the ocular micrometer (§ 240), or by moving the eye lens of the ocular up and down while looking into the micro-spectroscope until

the dark lines of the solar spectrum are distinct. If they cannot be made distinct by focusing the slit, then the light is too feeble or the slit is too wide. With the lever move the comparison prism across half the field so that the two spectra shall be of equal width. For lighting, see § 407.

§ 411a. If one does not possess a micro-spectroscope, quite satisfactory results may be obtained by using a microscope with a 16 to 12 mm. objective and a pocket direct-vision spectroscop in place of the eye-piece. (Bleile, *Trans. Amer. Micr. Soc.*, 1900, p. 8.)

§ 412. **Absorption spectrum of permanganate of potash.** — Make a solution of permanganate of potash by putting a few crystals in a watch glass of water. The solution should be of a strength that a stratum of 3 to 4 mm. thickness will be transparent. Place the watch glass under the microscope. Use a 16 mm. or lower objective and open widely the condenser diaphragm; light strongly. Look into the spectroscop and slowly move the watch glass into the field. Note carefully the appearance with the thin stratum of liquid at the edge and then as it gradually thickens on moving the watch glass still farther along. Count the absorption bands and note particularly the red and blue ends. Compare with the comparison spectrum (fig. 148). For strength of solution see § 410.

§ 413. **Absorption spectrum of blood.** — Obtain blood from a recently killed animal, or flame a needle, and after it is cool prick the finger two or three times in a small area; then wind a handkerchief or a rubber tube around the base of the finger and squeeze the finger with the other hand. Some blood will ooze out of the pricks. Rinse this off into a watch glass partly filled with water. Continue to add the blood until the water is quite red. Place the watch glass of diluted blood under the microscope in place of the permanganate, using the same objective, etc. Note carefully the spectrum. It would be advantageous to determine the wave length opposite the center of the dark bands. This may easily be done by setting the scale properly, as described in § 405. Make another preparation, but use a homœopathic vial instead of a watch glass. Cork the vial and lay it down upon the stage of the microscope. Observe the spectrum. It will be like that in the watch-glass. Remove the cork

and look through the whole length of the vial. The bands will be much darker, and if the solution is thick enough only red and a little orange will appear. Re-insert the cork and incline the vial so that the light traverses a very thin layer, then gradually elevate the vial and the effect of a thicker and thicker layer may be seen. Note especially that the two characteristic bands unite and form one wide band as the stratum of liquid thickens. Compare with the following:

Add to the vial of diluted blood a drop or two of ammonium sulphide, such as is used for a reducing agent in chemical laboratories.

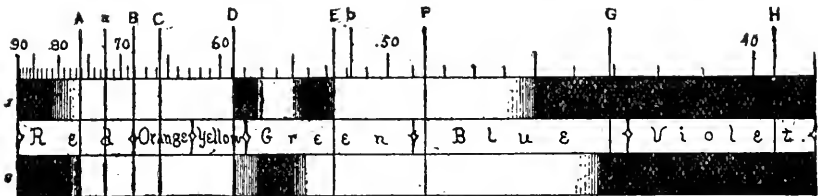

FIG. 140. ABSORPTION SPECTRUM OF ARTERIAL AND OF VENOUS BLOOD.
(From Gamgee and McMunn).

1 Absorption of arterial blood, oxy-hemoglobin. There are two definite bands between wave lengths 0.60μ and 0.50μ , that is, in the yellow-green, and the blue end of the spectrum is cut down markedly.

2 Single dark band of venous blood, hemoglobin, in the yellow-green. The blue end of the spectrum is less cut off than with arterial blood.

A B C D E F G H Fixed lines of the solar spectrum .90, .80, .70, .60, .50, .40; wave lengths in microns in the different regions. These spectra have the red end at the left instead of to the right, as is now more usual (fig. 144-147).

Shake the bottle gently and then allow it to stand for ten or fifteen minutes. Examine it and the two bands will have been replaced by a single, less clearly defined band in about the same position. The blood will also appear somewhat purple. Remove the cork to admit fresh air, then shake the vial vigorously, and the color will change to the bright red of fresh blood. Examine it again with the spectroscope and the two bands will be visible. After five or ten minutes another examination will show but a single band. Incline the bottle so that a thin stratum may be examined. Note that the stratum of liquid must be considerably thicker to show the absorption band than was necessary to show the two bands in the first

experiment. Furthermore, while the single band may be made quite black on thickening the stratum, it will not separate into two bands with a thinner stratum. In this experiment it is very instructive to have the watch glass of arterial blood under the microscope and the vial of blood to which has been added the ammonium sulphide in position for a comparison spectrum.

The two-banded spectrum is that of oxy-hemoglobin, or arterial blood; the single-banded spectrum of hemoglobin (sometimes called reduced hemoglobin) or venous blood, that is, the respiratory oxygen is present in the two-banded spectrum but absent from the single-banded spectrum. When the bottle was shaken the hemoglobin took up oxygen from the air and became oxy-hemoglobin, as occurs in the lungs, but soon the ammonium sulphide took away the respiratory oxygen, thus reducing the oxy-hemoglobin to hemoglobin. This may be repeated many times (fig. 149).

§ 414. **Met-hemoglobin.** — The absorption spectrum of met-hemoglobin is characterized by a considerable darkening of the blue end of the spectrum and of four absorption bands, one in the red near the line C and two between D and E, nearly in the place of the two bands of oxy-hemoglobin; finally there is a somewhat faint, wide band near F. Such a met-hemoglobin spectrum is best obtained by making the solution of blood in water of such a concentration that the two oxy-hemoglobin bands run together, and then adding three or four drops of a 0.1% aqueous solution of permanganate of potash. Soon the bright red will change to a brownish color, when it may be examined (fig. 148). Instead of the permanganate one may use hydrogen dioxide (H_2O_2).

§ 415. **Carbon monoxide hemoglobin (CO-hemoglobin).** — To obtain this, kill an animal in illuminating gas, or one may allow illuminating gas to bubble through some blood already taken from the body. The gas should bubble through a minute or two. The oxygen will be displaced by carbon monoxide. This forms quite a stable compound with hemoglobin, and is of a bright cherry-red color. Its spectrum is nearly like that of oxy-hemoglobin, but the bands are farther toward the blue. Add several drops of ammonium sulphide and allow the blood to stand some time. No reduction will take

place, thus forming a marked contrast to solutions of oxy-hemoglobin. By the addition of a few drops of glacial acetic acid a dark brownish red color is produced.

§ 416. **Carmine solution.** — Make a solution of carmine by putting 0.1 gram of carmine in 100 cc. of water and adding 10 drops of strong ammonia. Put some of this in a watch glass or in a small vial and compare the spectrum with that of oxyhemoglobin or carbon-monoxide hemoglobin. It has two bands in nearly the same position, thus giving the spectrum a striking similarity to blood. If now several drops, 15 or 20, of glacial acetic acid are added to the carmine, the bands remain and the color is not markedly changed, while with either oxy-hemoglobin or CO-hemoglobin the color is decidedly changed from the bright red to a dull reddish brown, and the spectrum, if any can be seen, is markedly different. Carmine and O-hemoglobin can be distinguished by the use of ammonium sulphide, the carmine remaining practically unchanged while the blood shows the single band of hemoglobin (§ 413). The acetic acid serves to differentiate the CO-hemoglobin as well as the O-hemoglobin.

§ 417. **Colored bodies not giving banded spectra.** — Some quite brilliantly colored objects, like the skin of a red apple, do not give a banded spectrum. Take the skin of a red apple, mount it on a slide, put on a cover-glass, and add a drop of water at the edge of the cover. Put the preparation under the microscope and observe the spectrum. Although no bands will appear, in some cases at least, yet the ends of the spectrum will be restricted and various regions of the spectrum will not be so bright as the comparison spectrum. Here the red color arises from the mixture of the unabsorbed waves, as occurs with other colored objects. In this case, however, not all the light of a given wave length is absorbed; consequently there are no clearly defined dark bands, the light is simply less brilliant in certain regions and the red rays so predominate that they give the prevailing color.

§ 418. **Nearly colorless bodies with clearly marked absorption spectra.** — In contradistinction to the brightly colored objects with no distinct absorption bands are those nearly colorless bodies and solutions which give as sharply defined absorption bands as could be desired. The best examples of this are afforded by solutions of the

rare earths, didymium, etc. These in solutions that give hardly a trace of color to the eye give absorption bands that almost rival the Fraunhofer lines in sharpness.

§ 419. **Absorption spectra of minerals.** — As example take some monazite sand on a slide and either mount it in balsam (see Ch. X), or cover and add a drop of water. The examination may be made also with the dry sand, but it is less satisfactory. Light well with transmitted light and move the preparation slowly around. Absorption bands will appear occasionally. Swing the prism tube off the ocular, open the slit, and focus the sand. Get the image of one or more grains directly in the slit, then narrow and shorten the slit so that no light can reach the spectroscope that has not traversed the grain of sand. The spectrum will be satisfactory under such conditions. It is frequently of great service in determining the character of unknown mineral sands to compare the spectra with known minerals. If the absorption bands are identical, it is strong evidence in favor of the identity of the minerals. For proper lighting see § 407.

§ 420. While the study of absorption spectra gives one a great deal of accurate information, great caution must be exercised in drawing conclusions as to the identity or even the close relationship of bodies giving approximately the same absorption spectra. The rule followed by the best workers is to have a known body as control and to treat the unknown body and known body with the same reagents, and to dissolve them in the same medium. If all the reactions are identical, then the presumption is strong that the bodies are identical or very closely related. For example, while one might be in doubt between a solution of oxy- or CO- hemoglobin and carmine, the addition of ammonium sulphide serves to change the double to a single band in the O-hemoglobin, and glacial acetic acid enables one to distinguish between the CO-blood and the carmine, although the ammonium sulphide would not enable one to make the distinction. Furthermore, it is unsafe to compare objects dissolved in different media. Different objects as "cyanine and aniline blue dissolved in alcohol give a very similar spectrum, but in water a totally different one." "Totally different bodies show absorption bands in exactly the same

position (solid nitrate of uranium and permanganate of potash in the blue)" (MacMunn). The rule given by MacMunn is a good one: "The recognition of a body becomes more certain if its spectrum consists of several absorption bands, but even the coincidence of these bands with those of another body is not sufficient to enable us to infer chemical identity, what enables us to do so with certainty is the fact, that the two solutions give bands of equal intensities in the same parts of the spectrum which undergo analogous changes on the addition of the same reagent. It should be borne in mind that the position of a band may be changed greatly through increased or diminished dissociation, and that the absorption bands given by a crystal may be quite different from those given by the same material in solution and furthermore that the absorption spectra are usually different in different directions through the crystal" (Chamot, p. 112).

MICRO-POLARISCOPE

§ 421. **The micro-polariscope**, or polarizer, is a polariscope used in connection with a microscope.

The most common and typical form consists of two Nicol prisms, that is, two somewhat elongated rhombs of Iceland spar cut diagonally and cemented together with Canada balsam. These Nicol prisms are then mounted in such a way that the light passes through them lengthwise, and in passing is divided into two rays of plane polarized light. The one of these rays obeying the ordinary law of refraction is called the ordinary ray, the one departing from the law is called the extraordinary rays. These two rays are polarized in planes at right angles to each other. The Nicol prism totally reflects the ordinary ray at the cemented surface as it meets that surface at an angle greater than the critical angle, and only the less refracted, extraordinary ray is transmitted.

§ 422. **Polarizer and analyzer.** — The polarizer is the Nicol prism placed beneath the object and by means of it the object is illuminated with polarized light. The analyzer is the Nicol placed at some level above the object, very conveniently above the ocular.

When the corresponding faces of the polarizer and analyzer are

parallel, i.e. when the faces through which the oblique section passes are parallel, light passes freely through the analyzer to the eye. If

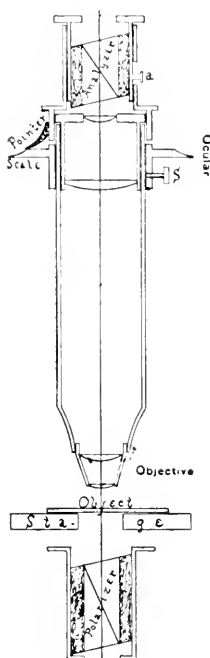

FIG. 150. MICRO-POLARISCOPE IN POSITION ON THE MICROSCOPE.

Polarizer The Nicol prism under the stage of the microscope.

Analyzer The Nicol prism over the ocular.

Stage The stage of the microscope.

Object The object on a slide.

Objective The microscopic objective.

S Set screw for clamping the analyzer to the tube of the microscope.

Ocular The microscopic ocular in position.

Pointer and Scale The graduated ring and pointer to show the amount of rotation.

A Handle for raising and lowering the analyzer to arrange it properly with reference to the eye-point.

these corresponding faces are at right angles, that is, if the Nicols are crossed, then the light is entirely cut off and the two transparent prisms become opaque to ordinary light. There are then, in the com-

plete revolution of the analyzer, two points 180° apart where the corresponding faces are parallel and where light freely traverses the analyzer. There are also two crossing points of the Nicols, midway between the parallel positions, where the light is extinguished. In the intermediate positions there is a sort of twilight.

§ 423. **Putting the polarizer and analyzer in position.** — Swing the diaphragm carrier of the condenser out from under the condenser, open widely the iris diaphragm, and place the polarizer in the diaphragm carrier; then swing it back under the condenser. Remove the ocular, put the graduated ring on the top of the tube, and then replace the ocular and put the analyzer over the ocular and ring. Arrange the graduated ring so that the indicator shall stand at 0° when the field is lightest, or darkest. This may be done by turning the tube down so that the objective is near the condenser, then shading the stage so that none but polarized light shall enter the microscope. Rotate the analyzer until the lightest possible point is found, then rotate the graduated ring until the index stands at 0° . The ring may then be clamped to the tube by the side screw for the purpose. Or, more easily, one may set the index at 0° , clamp the ring to the microscope, then rotate the draw-tube of the microscope till the field is lightest, or if the darkest point is made zero, rotate the draw-tube until the field is darkest.

§ 424. **Adjustment of the analyzer.** — The analyzer should be capable of moving up and down on its mounting, so that it can be adjusted to the eye-point of the ocular with which it is used. If on looking into the analyzer with parallel Nicols the edge of the field is not sharp, or if it is colored, the analyzer is not in the proper position with reference to the eye-point, and should be raised or lowered till the edge of the field is perfectly sharp and as free from color as the ocular itself is when the analyzer is removed.

§ 425. **Objectives to use with the polariscope.** — Objectives of all powers may be used, including the homogeneous immersion. In general, however, the lower powers are somewhat more satisfactory. A good rule to follow in this case is the general rule in all microscopic work, — use the power that most clearly and satisfactorily shows the object under investigation.

§ 426. **Lighting for micro-polariscope work.** — Follow the general directions given in Chapter II. It is especially necessary to shade the object so that no unpolarized light can enter the objective, otherwise the field cannot be sufficiently darkened. No diaphragm is used over the polarizer for most examinations. Direct sunlight may be used to advantage with some objects, and the object should be as transparent as possible.

§ 427. **Mounting objects for the polariscope.** — So far as possible objects should be mounted in balsam to render them transparent. In many cases objects mounted in water do not give satisfactory appearances with the polariscope. For example, if starch is mounted dry or in water, the appearances are not so striking as if mounted in balsam (Davis, p. 337).

§ 428. **Purpose of a micro-polariscope.** — (1) To determine whether a microscopic object is singly or doubly refractive, i.e., isotropic or anisotropic. (2) To determine whether or not a body shows pleochroism. (3) To show whether an object rotates the plane of polarization, as with sugar. (4) To give beautiful colors.

For petrological and mineralogical investigations the microscope should possess a graduated, rotating stage so that the object can be rotated and the exact angle of rotation determined. It is also found of advantage in investigating objects with polarized light where colors appear, to combine a polariscope and spectroscope (spectro-polariscope).

MICRO-POLARISCOPE EXPERIMENTS

§ 429. Arrange the polarizer and analyzer as directed above (§ 423) and use a 16 mm. objective except when otherwise directed.

(1) *Isotropic or singly refracting objects.* — Light the microscope well and cross the Nicols, shade the stage, and make the field as dark as possible. For an isotropic substance, put an ordinary glass slide under the microscope. The field will remain dark. As an example of crystals belonging to the cubical system and hence isotropic, make a strong solution of common salt (sodium chloride), put a drop on a slide, and allow it to crystallize; put it under the microscope, remove the analyzer, focus the crystals, and then replace the

analyzer and cross the Nicols. The field and the crystals will remain dark.

(2) *Anisotropic or doubly refracting objects.* — Make a fresh preparation of carbonate of lime crystals like that described for pedesis (§ 209), or use a preparation in which the crystals have dried to the slide; use a 5 or 3 mm. objective, shade the object well, remove the analyzer, and focus the crystals; then replace the analyzer. Cross the Nicols. In the dark field will be seen multitudes of shining crystals, and if the preparation is a fresh one in water, part of the smaller crystals will alternately flash and disappear. By observing carefully, some of the larger crystals will be found to remain dark with crossed Nicols, others will shine continuously. If the crystals are in such a position that the light passes through parallel with the optic axis (§ 429a), the crystals are isotropic like salt crystals and remain dark. If, however, the light traverses them in any other direction, the ray from the polarizer is divided into two constituents vibrating in planes at right angles to each other, and one of these will traverse the analyzer; hence such crystals will appear as if self-luminous in a dark field. The experiment with these crystals from the frog succeeds well with a 2 mm. homogeneous immersion.

As a further illustration of anisotropic objects, mount some cotton fibers in balsam (Ch. X), also some of the lens-paper (§ 158). These furnish excellent examples of vegetable fibers; striated muscle fibers are also very well adapted for polarizing objects.

(3) *Pleochroism.* — This is the exhibition of different tints as the analyzer is rotated. An excellent subject for this will be found in blood crystals.

§ 429a. The optic axis of doubly refracting crystals is the axis along which the crystal is not doubly refracting, but isotropic like glass. When there is but one such axis, the crystal is said to be uniaxial; if there are two such axes, the crystal is said to be bi-axial.

The crystals of carbonate of lime from the frog (see § 209) are uniaxial crystals. Borax crystals are bi-axial.

§ 430. *Starch.* — One of the most important uses of a polariscope is for the study of starch. Starch gives a characteristic black cross which rotates as the analyzer is rotated. Make a thin slice of fresh raw potato with a razor or other sharp knife and mount it in water.

Use first a 16 mm. and then a higher power. The starch grains, many of them, will be found in the potato cells. They have the general appearance of a clam or oyster shell. The black cross is strikingly exhibited by the polariscope. Starch grains of other plants show the same, but the grains are generally smaller and therefore do not bring out the structural features so clearly.

§ 431. **Production of colors.** — For the production of gorgeous colors, a selenite plate is placed anywhere between the polarizer and the analyzer. If properly mounted the selenite is very conveniently placed on the diaphragm carrier of the condenser, just above the polarizer; an unmounted selenite may be placed over the ocular. A thin plate or film of mica also answers well.

It is not necessary to use selenite or mica for the production of vivid colors in many objects. One of the most beautiful preparations and one of the most instructive also, may be prepared as follows: Heat some xylene balsam on a slide until the xylene is nearly evaporated. Add some crystals of the 'medicine' sulphonal and warm till the sulphonal is melted and mixes with the balsam. While the balsam is still melted put on a cover-glass. If one gets perfect crystals there will be shown beautiful colors and the black cross (Clark).

It is very instructive and interesting to examine many organic and inorganic substances with a micro-polarizer.

COLLATERAL READING

Chamot, *Chemical Microscopy*; Daniell, *Principles of Physics*; McMunn, *The Spectroscope in Medicine*.

CHAPTER IX

OPTICS OF THE MICROSCOPE

§ 440. Apparatus and material for Chapter IX.

- | | |
|--|---|
| 1. Microscope with oculars and objectives. | 4. Homogeneous immersion tester. |
| 2. Convex and concave lenses. | 5. Ocular micrometer; stage micrometer. |
| 3. Apertometer. | 6. Homogeneous immersion condenser. |

§ 441. **Optical facts of prime importance for the microscope.** — In considering the optics of the microscope six fundamental facts concerning light must be kept constantly in mind, for all of them are involved to a greater or less degree in every microscopic observation:

(1) Light is composed of radiation which for visual purposes consists of waves from $\lambda 0.4\mu$ to $\lambda 0.7\mu$ in length.

(2) Light in a uniform medium extends in straight lines.

(3) Light may be reflected.

(4) Light is refracted in passing from one medium to another of different density.

(5) Light may be dispersed or grouped into colored rays from the fact that rays of different wave length are differently bent (fig. 145, 2).

(6) Light may be diffracted.

Stated in briefest terms light exhibits the properties of:

(1) Wave motion; (2) Rectilinear motion; (3) Reflection; (4) Refraction; (5) Dispersion; (6) Diffraction.

§ 442. **Wave motion.** — From a body like the sun, the electric arc and other sources of energy, radiations are given off in waves. The radiation which is visible, forms but a very small segment of the total radiation. In fig. 151 the visible radiation is shown between wave lengths $\lambda 0.4\mu$ and $\lambda 0.7\mu$, measured in air or in a vacuum. Shorter waves are called ultra-violet, and longer waves infra-red.

The infra-red waves are only shown up to a length of 2μ , although many of much greater length exist.

In the ether of space the different visible waves move with equal velocity, but in the various transparent bodies on the earth, the velocity depends upon the wave length — the shorter the waves the slower the motion (§ 451).

§ 443. **Light moves in straight lines.** — In a uniform medium light moves in straight lines. Any body in which light can move

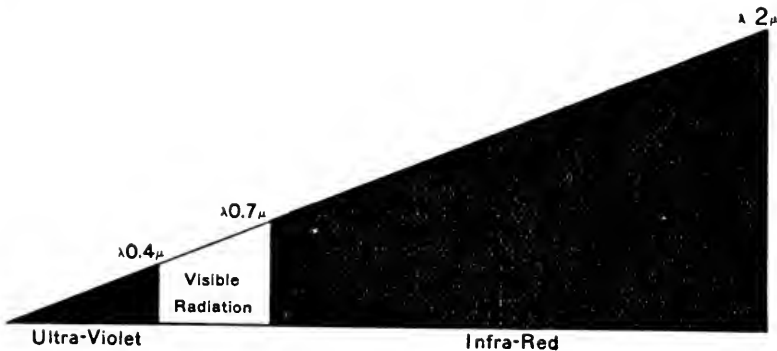

FIG. 151. VISIBLE AND INVISIBLE RADIATION.

The segment in white shows the visible radiation, which lies between $\lambda 0.4\mu$ and $\lambda 0.7\mu$. Radiation shorter than $\lambda 0.4\mu$ is known as ultra-violet, and longer than $\lambda 0.7\mu$ as infra-red. This is a normal spectrum magnified 20,000 vertically and 50,000 times horizontally (see also fig. 144).

freely is said to be transparent. If light meets a body in which it cannot move it is either reflected (§ 444) or absorbed; if absorbed it is changed to some other form of energy, usually heat.

§ 444. **Reflection.**— If light meets a surface which is opaque or only partly transparent, it is changed in its course or reflected; or it may be absorbed.

If the surface is smooth and the light is reflected, the incident and the reflected ray will be in the same plane and will make equal angles on opposite sides of a normal erected at the point of reflection (fig. 152). The eye can see the light only when in the path of the ray, or when light is deflected from the ray by dust, etc. (§ 117).

If the surface is irregular the reflection will also be irregular and the light will be reflected from the point of incidence in the form of a

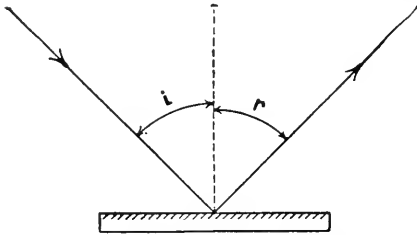

FIG. 152. REGULAR OR MIRROR REFLECTION.

(From Optic Projection).

The angle of incidence i , is equal to the angle of reflection r ; and the incident and reflected ray are in a plane perpendicular to the reflecting surface.

another is this: Refraction is the change in velocity of the waves of light in passing from one transparent medium into another.

§ 446. **Law of refraction.** — The amount of bending depends upon two factors, — the relative density of the two media and the obliquity of the incident light. The greater the obliquity of the incident ray, and the greater the difference in density, the greater will be the refraction. The precise law governing the course and relation of the ray in the two media is known as the sine law of Snell and Descartes. It is expressed thus:

$$\frac{\sin i}{\sin r} = \text{index of refraction.}$$

That is, the sine of the angle of the incident ray with the normal, divided by the sine of the angle of the refracted ray with its normal, gives the relative direction of the ray in the two media, i.e., the index of refraction. For

example in fig. 154, showing the passage of light to water, the ray being at 60° with the normal in air, and $40^\circ 38'$ in water, the real

hemisphere (fig. 153), hence light would reach the eye from any point in the hemisphere.

§ 445. **Refraction.** — As ordinarily considered, this is the change in direction which light undergoes when passing obliquely from one transparent medium into another (fig. 154-156).

A broader statement covering all the phenomena whether the ray passes obliquely or normally from one medium to

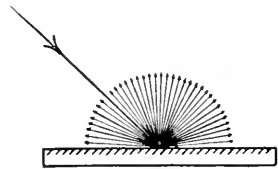

FIG. 153. IRREGULAR OR DIFFUSE REFLECTION.

(From Optic Projection).

A ray of light meeting a rough surface, like a piece of white paper, is scattered almost equally in all directions, making a hemisphere of light.

relationship in this and in all other cases is not the relative size of the two angles, but the sines of the angles, thus: $\frac{\sin i \text{ or } 0.86603}{\sin r \text{ or } 0.65115} = 1.33$.

That is, the sine of the angle in air is 1.33 times the sine of the angle in water; and this would hold true for any other pair of sines, so that the law is universal for the wave length of light giving this index of refraction.

The sine and corresponding angle are always greater in the rarer medium and consequently less in the denser medium. It follows from this that when the ray passes from a rarer to a denser medium and the angle is made less, the ray must bend *toward* the normal. Conversely in passing from a denser to a rarer medium where the angle is greater, the ray must bend *from*

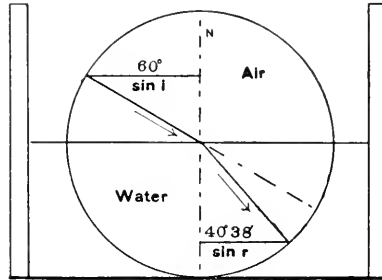

FIG. 154. REFRACTION OF LIGHT IN PASSING FROM AIR TO WATER.

N Normal at the point of refraction.
 $\frac{\sin i}{\sin r}$ In this example $\sin 60^\circ$ or 0.86603
 $\frac{\sin i}{\sin r}$ In this case $\sin 40^\circ 38'$ or 0.65115
 = 1.33, average index of refraction for air and water.

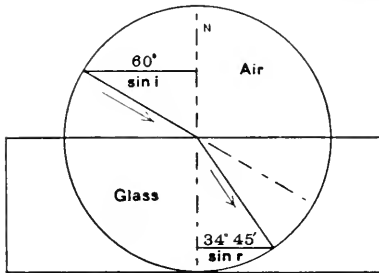

FIG. 155. REFRACTION OF LIGHT IN PASSING FROM AIR TO GLASS.

N Normal at the point of refraction.
 $\frac{\sin i}{\sin r}$ In this example $\sin 60^\circ$ or 0.86603
 $\frac{\sin i}{\sin r}$ In this example $\sin 34^\circ 45'$ or 0.59075
 = 1.52, average index of refraction for air and glass.

the normal. This is a general law (see fig. 155, 157).

§ 447. **Absolute index of refraction.** — This is the index of refraction obtained when the incident ray passes from a vacuum into a given medium. As the index of the vacuum is taken as unity, the absolute index of any substance is always greater than unity. For many purposes, as for the object of this book, air is treated as if it were a vacuum, and its index is called unity, but in reality the index of refraction of air is about 3 ten-thousandths

greater than unity. Whenever the refractive index of a substance is given, the absolute index is meant unless otherwise stated. For example, when the index of refraction of water is said to be 1.33, and of crown glass 1.52, etc., these figures represent the absolute index, and the incident ray is supposed to be in a vacuum.

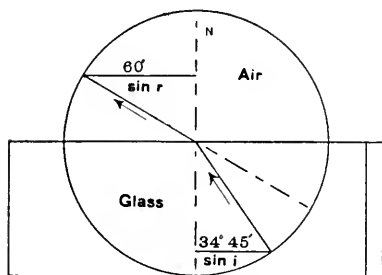

FIG. 156. REFRACTION OF LIGHT IN PASSING FROM GLASS TO AIR.

N Normal to the refracting surface.

$\frac{\sin i}{\sin r}$ In this case $\sin 34^\circ 45'$ or 0.56975

$\frac{\sin r}{\sin i}$ In this case $\sin 60^\circ$ or 0.86603

$$= \frac{1}{1.52}$$

If fig. 155 and 156 are compared it will be seen that the ray of light follows exactly the same path in leaving the denser medium that it took on entering it.

By a study of the figures showing refraction, it will be seen that the greater the refraction the less the angle and consequently the less the sine of the angle, and as the refraction between two media is the ratio of the sines of the angles of incidence and refraction $\left(\frac{\sin i}{\sin r}\right)$, it will

be seen that whenever the sine of the angle of refraction is increased by being in a less refractive medium, the index of refraction will show a corresponding decrease and *vice versa*. That is, the ratio of the sines of the angles of incidence and refraction of any two contiguous substances is inversely as the refractive indices of those substances. The formula is:

$$\left(\frac{\text{Sine of angle of incident ray}}{\text{Sine of angle of refracted ray}}\right) = \left(\frac{\text{Index of refraction of refracting medium}}{\text{Index of refraction of incident medium}}\right)$$

§ 448. **Relative index of refraction.** — This is the index of refraction between two contiguous media, as for example between glass and diamond, water and glass, etc. It is obtained by dividing the absolute index of refraction of the substance containing the refracted ray, by the absolute index of the substance transmitting the incident ray. For example, the relative index from water to glass is 1.52 divided by 1.33. If the light passed from glass to water it would be, 1.33 divided by 1.52.

By a study of the figures showing refraction, it will be seen that the greater the re-

Abbreviated $\left(\frac{\sin i}{\sin r}\right) = \left(\frac{\text{index } r}{\text{index } i}\right)$. By means of this general formula one

can solve any problem in refraction whenever three factors of the problem are known. The universality of the law may be illustrated by the following cases:

(A) Light incident in a vacuum or in air, and entering some denser medium, as water, glass, diamond, etc.

$$\left(\frac{\text{Sine of angle made by the ray in air}}{\text{Sine of angle made by ray in denser med.}}\right) = \left(\frac{\text{Index of ref. of denser med.}}{\text{Index of ref. of air (1)}}$$

If the dense substance were glass $\left(\frac{\sin i}{\sin r}\right) = \left(\frac{1.52}{1}\right)$. If the two media were

water and glass, the incident light being in water the formula would be:

$$\left(\frac{\sin i}{\sin r}\right) = \left(\frac{1.52}{1.33}\right)$$

If the incident ray were glass and the refracted ray in water: $\left(\frac{\sin i}{\sin r}\right) = \left(\frac{1.33}{1.52}\right)$. And similarly for any two media; and as stated

above if any three of the factors are given the fourth may be readily found.

§ 449. **Critical angle and total reflection.** — In order to understand the Wollaston camera lucida (fig. 99) and other totally reflecting apparatus, it is necessary briefly to consider the critical angle.

The *critical angle* is the greatest angle that a ray of light in the denser of two contiguous media can make with the normal and still emerge into the less refractive medium. On emerging it will form an angle of 90° with the normal, and if the substances are liquids, the refracted ray will be parallel with the surface of the denser medium.

Total Reflection. — In case the incident ray in the *denser* medium is at an angle with the normal greater than the *critical angle*, it will be *totally reflected* at the surface of the denser medium, that surface acting as a perfect mirror. By consulting the figures it will be seen that there is no such thing as a critical angle and total reflection in the *rarer* of two contiguous media.

To find the critical angle in the denser of two contiguous media: —

Make the angle of refraction (i. e., the angle in the rarer of the two media) 90° and solve the general equation: $\left(\frac{\sin i}{\sin r}\right) = \left(\frac{\text{index } r}{\text{index } i}\right)$.

(1) Critical angle of water and air: $\sin r$ (90°) is 1, index of water 1.33 whence $\left(\frac{\sin i}{1}\right) = \left(\frac{1}{1.33}\right)$ or $\sin i = 751+$. This is the sine of $48^\circ 45'$, and whenever the ray in

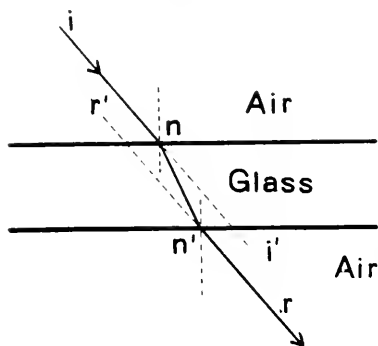

FIG. 157. DISPLACEMENT OF A RAY OF LIGHT IN TRAVERSING AN OBJECT WITH PLANE FACES.

This figure is to show that while there is no angular deviation of a ray of light in traversing a dense medium with plane faces, there is displacement; but the emerging ray (r) is parallel with the entering ray (i).

Air Glass The two media through which the ray is traveling.

i n Incident ray and normal at the point of entrance into the glass.

i' Incident ray continued by dotted lines to show the path which would have been followed if no glass had intervened.

$n'r$ Normal and refracted ray on emergence from the glass to the air again.

r' Path of the refracted ray traced backward.

The last shows the advantage of water immersion when a large angle of light is desired. With homogeneous immersion there would be no critical angle for the glass.

§ 449a. **Critical angle.** — As defined by some physicists the critical angle is the least angle at which light undergoes total internal reflection at the surface of the denser medium.

the water is at an angle of more than $48^\circ 45'$ it will not emerge into the air, but be totally reflected back into the water.

(2) Critical angle of glass and air: $\sin r$ (90°) is 1, index for glass is 1.52, whence $\frac{\sin i}{1} = \frac{1}{1.52} =$

$\sin 0.65789$, which is the sine of $41^\circ+$. Light having a greater angle in glass than 41° is internally reflected as from a mirror (fig. 152), and reflected back into the glass.

(3) Critical angle of glass covered with water.

$$\left(\frac{\sin i}{\sin r (\sin 90^\circ = 1)}\right) = \left(\frac{\text{index water (1.33)}}{\text{index glass (1.52)}}\right) \text{ or } \left(\frac{\sin i}{1}\right) = \left(\frac{1.33}{1.52}\right).$$

whence $\sin i = .875$ sine of critical angle in glass covered with water. The corresponding angle is approximately 61° .

I have followed the more common definition which makes it the greatest angle at which a ray can emerge into the rarer medium; the emerging angle will then be 90° and its sine 1.000.

§ 450. Table of refractive indices. (From Chamot).

(Temperature 20 to 22 C.)

Index of Refraction	Name of Substance	Approximate Boiling Point °C	Approximate Density
1.32	Methyl alcohol	66	0.79
1.36	Ethyl ether	35	0.71
1.37	Ethyl alcohol	78	0.79
1.46	Cajeput oil	174	0.92
1.44	Chloroform	61	1.48
1.47	Glycerine	290	1.61
1.47	Turpentine	155	0.86
1.48	Castor oil	...	0.96
1.49	Xylene	136	0.86
1.49	Benzene	80	0.88
1.50	Clove oil	...	1.05
1.51	Cedar Wood oil	...	0.98
1.57	Orthotoluidine	197	1.00
1.625	Carbon bisulphide	46	1.29
1.52±	Canada balsam
1.52-1.59	Glass
1.544-1.553	Quartz

§ 451. The sine law and the velocity of light in different media.—

In the ether of space all wave lengths of light move with equal velocity, but on the earth the velocity depends on the wave length. While all wave lengths are retarded by shortening the waves, the shorter the original wave the greater the retardation. As the refraction of the light is one of the phenomena of this retardation it follows that the shorter the wave the greater the bending. This is shown by the action of the prism (fig. 145, 2), in which the blue is more deviated than the red.

The retardation of any given wave length (i.e. the relative shortening of the waves) follows the sine law in passing from one transparent substance to another. For example, in passing from the ether to

water the speed in water would be represented by: $\frac{\sin i}{\sin r}$ or 1.334 for

waves at the D Fraunhofer line (Watson). This means that if the speed in the ether were v , that in water for this wave length the velocity would be $\frac{v}{1.334}$. In terms of the angle of the light, if the sine of the angle in the ether is v , the sine of the angle of this wave length in water would be $\frac{v}{1.334}$.

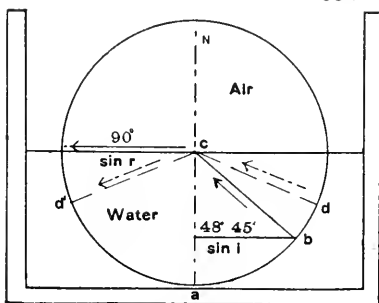

FIG. 158.

FIG. 158. CRITICAL ANGLE FOR LIGHT PASSING FROM WATER TO AIR, THE ANGLE IN AIR BEING 90° .

N Normal to the refracting surface.

$\frac{\sin i}{\sin r}$ In this case $\sin 48^\circ 45'$ or $0.7510 = \frac{v}{1.33}$, in accordance with the general

formula: $\frac{\sin i}{\sin r} = \frac{\text{index } r}{\text{index } i}$

b Light ray at the critical angle and emerging into the air parallel with the surface of the water.

$d d'$ Ray of light at an angle greater than the critical one and being internally reflected back into the water; the angle of incidence and reflection being equal (fig. 152).

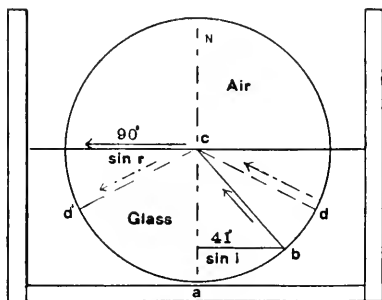

FIG. 159.

FIG. 159. CRITICAL ANGLE FOR LIGHT PASSING FROM GLASS TO AIR, THE ANGLE IN AIR BEING 90° .

N Normal to the refracting surface.

$\frac{\sin i}{\sin r}$ In this case $\sin 41^\circ$ or $0.65789 = \frac{v}{1.52}$, in accordance with the general

formula: $\frac{\sin i}{\sin r} = \frac{\text{index } r}{\text{index } i}$

b Light ray at the critical angle and emerging into the air parallel with the surface of the glass.

$d d'$ Ray of light at an angle greater than the critical angle and being reflected back into the glass, the angle of incidence and reflection being equal (fig. 152).

For crown glass the waves opposite the fixed line *B*, if possessed of a speed of 1 in the ether, would have a speed in the glass of $\frac{1}{1.531}$.

Opposite the *H* line, with the shorter waves, the speed would be $\frac{1}{1.551}$ in crown glass.

That is, then, just as in refraction (§ 445-446), if the velocity in one medium and the index of refraction of the two media are known the velocity in the second medium can be determined; and in general knowing any three factors the fourth can be determined.

While for the discussion of lenses the narrower view of refraction may suffice, for optical instruments generally it is of fundamental importance to realize that there is just as much effect on light waves striking the surface of the refracting body perpendicularly as obliquely. In one case, that of the oblique meeting, the ray is bent due to the shortening of the waves in passing from a rarer to a denser medium. If the waves meet the denser substance normally to its surface the ray will not be bent, but the shortening of the waves will be the same leading to an optical shortening of the path of the ray. This is of prime value when designing optical apparatus where two optical paths must be made equal, although the actual distance in millimeters may be unequal. The binocular microscope is a striking example (fig. 53-54). The

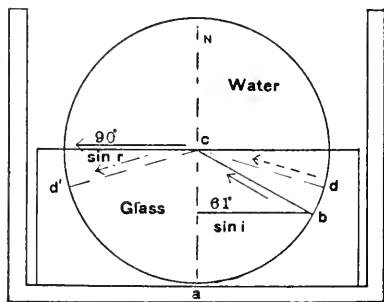

FIG. 160. CRITICAL ANGLE FOR LIGHT PASSING FROM GLASS TO WATER, THE ANGLE IN THE WATER BEING 90°.

N Normal to the refracting surface.
 $\frac{\sin i}{\sin r}$ In this case $\sin 61^\circ$ or $0.8750 = \frac{1.33}{1.52}$ in accordance with the general formula $\frac{\sin i}{\sin r} = \frac{\text{index } r}{\text{index } i}$.

b Light ray at the critical angle and emerging into the water at an angle of 90° from the normal.

d d' Ray of light at an angle greater than the critical angle and hence reflected back into the glass, the angle of incidence and reflection being equal.

The binocular microscope is a striking example (fig. 53-54). The

shortening of the path is also very strikingly illustrated by the cover-glass (fig. 31-32, § 80-81).

§ 452. **Dispersion.** — This is the separation of waves of composite light into groups which appear of different colors to the normal eye. If white light is dispersed there results the familiar rainbow, or spectrum.

As this dispersion is due to the different refrangibility of the different wave lengths, the shortest waves being most bent, one would expect that the amount of bending would be in exact proportion to the wave lengths. This is true if one uses a diffraction grating and forms a normal spectrum (fig. 146). When a prism is used to produce the dispersion (145, 2), the dispersion is not in exact relation to the wave length. In general the red end of the spectrum is condensed and the blue end expanded (fig. 147, 148-149). Different kinds of glass disperse differently and the same is true of transparent minerals, quartz, fluorite, etc. This makes achromatism possible. As pointed out by Newton, if the dispersion were in exact proportion to the wave length as with gratings, whenever dispersion is overcome, refraction would also be overcome and no achromatic combination of lenses would be possible.

§ 453. **Diffraction.** — This is the bending of light past the edge of objects. Instead of the light all going in a straight line beyond an object, especially a narrow strip, some of it extends as if split off from the main beam at the edge of the obstruction. These diffracted beams may give rise to independent or so-called spurious images. With low powers the diffracted light does not cause complications, but with high powers the diffraction fringes and diffraction disc may produce effects very difficult of interpretation. (See § 474 where there is a discussion of the part played by diffracted light in microscopic images.)

LENSES AND IMAGES

§ 454. **Lenses.** — A lens is a transparent body having one or both of its opposite sides curved. The curves are most frequently spherical, and may be either convex or concave. If both the surfaces are curved the lens may be considered as composed of segments of two spheres.

These spheres are of like radius if the surfaces are similarly curved, and of unlike radius if the surfaces are unlike. While a lens with one plane face may be considered a segment of a single sphere, optically it is better to consider two spheres, the curved surface from a sphere of finite, and the plane face from a sphere of infinite radius (fig. 167, 3, 6).

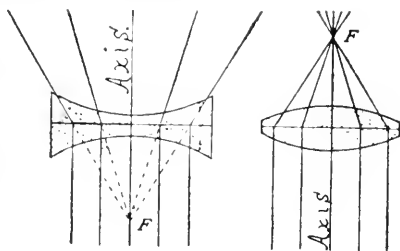

FIG. 161-162. A CONCAVE LENS SHOWING THE PRINCIPAL, VIRTUAL FOCUS; AND CONVEX LENS SHOWING THE REAL PRINCIPAL FOCUS (F F).

§ 455. Images formed by lenses. — As light entering a dense transparent body obliquely is bent toward the normal at the point of entrance, it follows that if the lens has convex faces the light rays will be made more convergent; if it has concave faces the light rays will be rendered more divergent (fig. 161-162). From the change in the direction of the rays on entering and on leaving a lens it is possible to form images of objects by means of lenses (fig. 163-166).

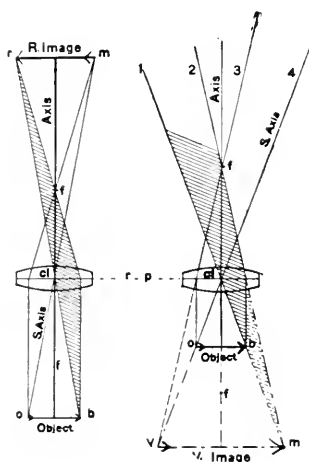

FIG. 163-164. TO SHOW THE FORMATION OF A REAL AND OF A VIRTUAL IMAGE BY A CONVEX LENS. (COMPARE FIG. 11-12).

The size of the image depends upon its relative distance from the center of the lens. If it is farther from the center than the object it will be larger than the object, but if nearer it will be smaller (fig. 84).

§ 456. Forms and principal features of spherical lenses. — As shown in fig. 167 lenses may be convex on both faces, or convex on one face and plane or concave on the other. Lenses may also be concave on both faces or concave on one face and plane or convex on the other.

If lenses are thick in the middle and thin on the edge, they make the rays of light entering them more convergent. On the other hand, if they are

thin in the middle and thick on the edge they make the light rays entering them more divergent. In a word, then, thin edge lenses are called convergent, and thick edge ones, divergent lenses. This follows inevitably from the rule that on entering a denser medium

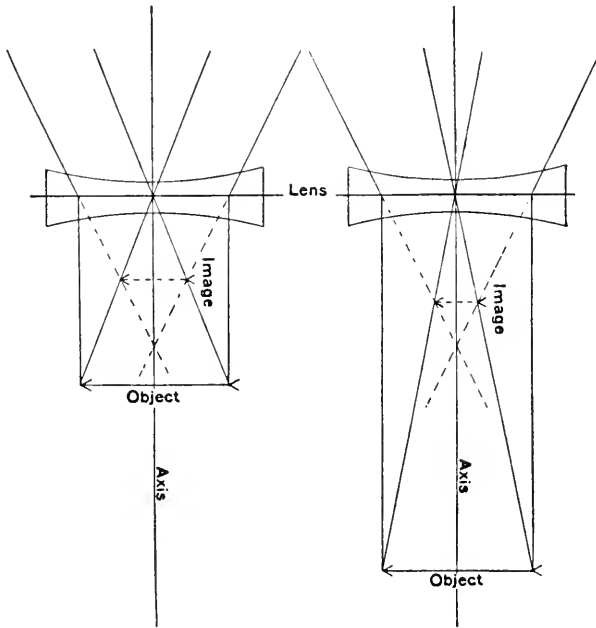

FIG. 165-166. TO SHOW THE FORMATION OF A REDUCED VIRTUAL IMAGE BY A CONCAVE LENS, AND THAT THE IMAGE IS LARGER THE NEARER THE OBJECT IS TO THE PRINCIPAL (VIRTUAL) FOCUS. (COMPARE FIG. 86-87).

any oblique ray of light is bent toward the normal, and on leaving it for a rarer medium, it is bent from the normal (§ 446.)

§ 457. **Principal features of spherical lenses**—(1) Principal axis. This is the straight line passing through the lens and joining the centers of the two spheres contributing to the formation of the lens (fig. 167, 4c c').

(2) Optic center. The point in a lens or near it through which light rays pass without angular deviation. That is, the ray

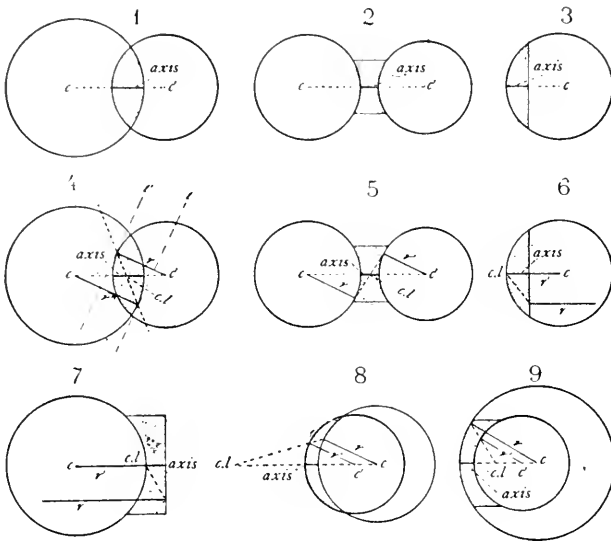

FIG. 167. SPHERICAL LENSES WITH THEIR FORMS AND PRINCIPAL FEATURES.

(1) Double convex lens showing the two spheres from which it was derived. $c-c'$ the centers of the two spheres with the principal axis of the lens on the line joining the centers.

(2) Double concave lens and the two spheres from which it was derived. $c-c'$ centers of the spheres and axis of the lens.

(3) Plano-convex lens with the sphere from which it was derived. In this case the axis is on the radius dividing the lens into two equal parts.

(4) Double convex lens showing the two spheres from which it was derived; r r' parallel radii; t t' tangents at the ends of the radii; c c' centers of the two spheres, on the connecting line of which is the principal axis of the lens, and the optic center (cl).

(5) Double concave lens showing the same features as in (4).

(6) Plano-convex lens showing the same as in (5). In this case the radius of the curved face is determined as usual, but that of the plane face may be considered infinity, so that any line perpendicular to the plane face is a part of that radius. As shown in the figure the center of the lens must be then at the convex surface of the lens.

(7) Plano-concave lens the parts are practically like (6).

(8) Thin edge or converging meniscus lens with the two spheres from which it was derived. The inner, concave face is from the greater sphere, and the optic center (cl) is wholly outside the lens.

(9) Thick edge or diverging meniscus lens. In this case the concave face is from the smaller sphere, and the center of the lens (cl) is on the concave side.

passing through the center of the lens continues in a line parallel to the original direction as it does in traversing a piece of plane glass (fig. 157).

As shown in the diagrams (fig. 167) the optic center is found by drawing parallel radii from the two curved surfaces, or from the curved and plane surface, and joining the ends of the radii. The center of the lens is at the point where a line connecting the ends of the radii crosses the principal axis (fig. 167, *c*). The reason why light rays traversing the optic center have no angular deviation is evident, for the radii are perpendicular to the surface of the lens, and the tangent plane perpendicular to the radius is tangent to the sphere at the end of the radius. As the tangents of two parallel radii must themselves be parallel, it follows that a ray of light passing from one tangential point to the other is traversing a body with parallel sides at the point of entrance and exit, and hence it will suffer no angular deviation. The ray may be displaced as in traversing any thick transparent body (fig. 157). With meniscus lenses the optic center (fig. 167, 8, 9) is on an extension of the line joining the centers of curvature, and wholly outside the lens.

(3) Secondary axis. This is any line which passes through the optic center of the lens and is oblique to the principal axis.

(4) Principal focal point. The principal focal point or focus of a lens or of a lens system like an objective, a simple microscope, etc., is the point on the principal axis where rays of light parallel to the principal axis before entering the lens or lens system, cross the principal axis after leaving the lens or objective (fig. 161-162). The focus is also called the burning point. With a concave mirror it is the point on the principal axis where rays parallel with the principal axis before meeting the mirror, cross the principal axis after reflection from the concave surface. This point is situated half-way between the face of the mirror and the center of curvature.

ABERRATION OF LENSES

§ 458. **Spherical aberration.** — This is a defect of spherical lenses shown in fig. 168. That is, the parallel ray at the edge crosses the principal axis or comes to a focus nearer the center of the lens than a

ray near the axis. If then the full aperture is filled, as shown in the figure, with rays parallel with the axis, there will be a series of foci, those of the border rays being nearer the lens than those near the middle of the lens (fig. 168, f_1 , f_2 , f_3).

§ 459. **Correction of spherical aberration.** — It is possible by selecting convex and concave lenses of different material and hence of different refractive power, to overcome the spherical aberration of the convex lens with an equal and opposite aberration in a concave lens without overcoming the converging action of the convex lens. Consequently rays will all come to one focus. Such a lens combination is said to be aplanatic or spherically corrected.

If the correction were not quite sufficient so that the border rays still came to a focus slightly nearer the lens than the middle rays, the combination would be *under-corrected*. If the concave lens were too strong, the border rays of the convex lens would come to a focus farther from the lens than the middle rays, and the combination would be said to be *over-*

corrected. Sometimes under-correction or over-correction is designed to compensate for parts of the optical apparatus which the rays will meet later, or for aberrations produced before the light reaches the objective. The common and almost universal example is the spherical aberration introduced by the cover-glass over the specimen (fig. 169).

§ 460. **Cover-glass correction.** — By referring to fig. 169 it will be seen that the effect of the cover-glass is precisely like the spherical aberration due to the unequal refraction of the different zones of a convex lens; that is, the border rays are more bent than those nearer the axis, as the obliquity of the rays is greater (§ 446).

Now to overcome this there must be introduced into the objective an under-correction just sufficient to balance the effect of the cover-

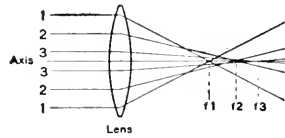

FIG. 168. SPHERICAL ABERRATION IN LENSES.

Axis The principal optic axis.

1 2 3 Ray 1 at the edge comes to a focus at f_1 ; ray 2 at f_2 , and ray 3 at f_3 , that is, the nearer the optic axis the longer the focus, and the nearer the edge of the lens the shorter the focus.

glass. If the lenses are fixed in position in the objective it will be evident that one must select a cover-glass which is of the exact thickness to satisfy the correction of the objective. The makers of objectives are now very precise in stating exactly how thick the covers should be for their objectives, and it is the part of wisdom to pay heed to their statements if one hopes to get the best results.

If one's objectives are adjustable (§ 134-135), it is possible to so arrange the combinations that quite a range of cover-glass thickness

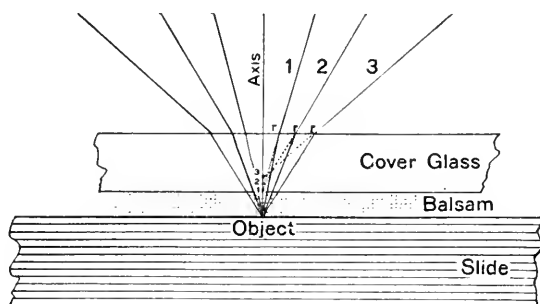

FIG. 169. SPHERICAL ABERRATION INTRODUCED BY THE COVER-GLASS.

Axis The principal optic axis extending through the condenser and up through the object and microscope.

Slide The glass slide on which the object is mounted.

Object The object to be studied; it is mounted on the slide.

Balsam The medium in which the object is mounted. It has practically the same refractive index as the cover.

Cover-glass The thin glass plate over the object.

1 2 3 The light rays extending obliquely upward from the object.

3 2 1 Light rays traced backward to their apparent origin, the most oblique ray (3) being most bent, thus rendering its origin apparently highest.

r r r Points of refraction of the three oblique rays.

or mounting medium thickness can be used and still get the best optical effect by balancing the aberrations (§ 462).

§ 461. **Tube-length.** — The length of the tube on the microscope must be made of the standard for which the objective used was corrected or aberrations will appear.

If the tube is shorter than the objective was corrected for, the

effect is the same as thinning the cover-glass. That is, it introduces under-correction. This makes it possible to compensate for too thick a cover by shortening the tube (§ 135, 462).

If the tube is made longer than the standard it has the same effect as using too thick a cover-glass. It therefore introduces over-correction, and if a cover too thin has been used it may be compensated for by lengthening the tube.

When homogeneous immersion liquid is used one does not have to trouble about the exact thickness, but care must be taken not to use so thick a cover that the working distance will be too short (§ 76).

By consulting the catalogues of microscope manufacturers one can find for what tube-length and thickness of cover-glass their unadjustable objectives are corrected. For example, in the 1914 editions of the catalogues of the Bausch & Lomb Optical Company of Rochester, and of the Spencer Lens Company of Buffalo, it is stated that the tube-length is 160 millimeters and as shown in the accompanying figure (fig. 170), it includes the parts from the upper end of the draw-tube to the nut into which the objective is screwed.

The cover-glass thickness is given as 0.18 millimeter, and the user is warned that for the higher powers a variation in thickness from this standard of 0.03 or 0.04 mm. would deteriorate markedly the perfection of the image. The statement is furthermore made that with the homogeneous immersions no harm would result, but on the other hand great care must be exercised there to use the correct tube-length or aberrations will be introduced.

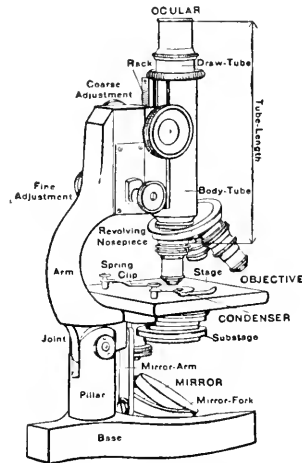

FIG. 170. THE MICROSCOPE SHOWING TUBE-LENGTH.

§ 462. Table showing cause of spherical aberration in the microscope and means of correction. —

Under-correction produced by:	Over-correction produced by:
1. Too weak a concave element in the objective.	1a. Too strong a concave element in the objective.
2. Too close an approximation of the lenses of the objective.	2a. Too great a separation of the lenses of the objective.
3. Too short a tube, that is the ocular and objective are too close together.	3a. Too long a tube, that is the ocular and objective are too far apart.
4. Use of too thin a cover-glass.	4a. Use of too thick a cover-glass.

Any defect can be neutralized by applying the right amount of what would produce the opposite condition. For example, the over-correction produced by too thick a cover-glass can be corrected by: (4) Using a thinner cover-glass; (3) Shortening the tube; (2) Putting the lenses of the objective closer together; (1) using a weaker concave element in the objective.

If there is under-correction from too short a tube it can be neutralized by: (3a) lengthening the tube; (4a) using a thicker cover-glass; (2a) separation of the lenses of the objective; (1a) using a stronger concave element in the objective. And similarly with under-correction or over-correction from any cause; opposites neutralize.

§ 463. **Chromatic aberration.** — Spherical aberration which has just been discussed is present in lenses even when the light is of one wave length; chromatic aberration, on the other hand, appears in addition when composite light traverses a lens. This is because every wave length of necessity is differently refracted; the shortest waves most, the longest waves least. If then a single beam of white light traverses a lens, the different wave lengths will be refracted differently and the blue-violet waves made to cross the axis first, the red waves last. There will be then a series of colored foci extending along the axis, as shown in fig. 171. Every simple lens, then, whose aperture is filled with composite light will show both spherical and chromatic aberration, and the greater the aperture and the shorter the focus the more pronounced will be both forms of aberration. In order that perfect images may be produced, both aberrations must be eliminated.

Fortunately the visible spectrum does not include a greater range of wave lengths (fig. 151), and if it were markedly less the optician would find his task greatly lightened. As shown in fig. 139, the brightest region of the spectrum to the eye is really limited, and the old opticians made good instruments for visual purposes by overcoming the aberrations in large part in this very limited region; but with the requirements of photography and for the most complete visual study of the phenomena and objects of nature by means of optical instruments greater and still greater demands were made for optical instruments including at least the whole visible spectrum, and for some purposes extending into the infra-red and the ultra-violet.

§ 464. **Correction of the aberrations of lenses.** — From the very law of refraction bound up with the different wave lengths of visible light it would seem impossible to obtain the refraction necessary to produce images (fig. 163-166) without at the same time dividing the light up into its colors. If the refraction of each wave length were in exact proportion to its length, as with a diffraction grating it would be impossible to produce achromatic images. Newton thought the refraction was always as with a grating, and he explained the satisfactory images produced by lenses on the ground that the narrow part of the spectrum most brilliant to the eye overwhelmed the dimmer parts so that the colored images on both sides of the visual image were ignored.

If one compares, however, the spectrum produced by the diffraction grating (fig. 146) with that produced by a glass prism (fig. 147) it will be seen that the refraction of the different wave lengths (disper-

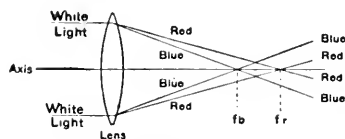

FIG. 171. CHROMATIC ABERRATION WITH COMPOSITE LIGHT.

White light A beam of white light composed of all the colors meeting a lens and the different wave lengths being differently refracted breaks the composite light up into its constituent colors.

Red Blue The long waved red light is less refracted than the shorter waved blue light. After crossing at the foci the blue light is on the outside of the diverging cone.

f_b , f_r The focus of the blue light (f_b) nearer the lens than the focus of the red light (f_r).

Axis The optic axis of the lens.

The dispersion or separation into colors differs with different transparent substances, and is not in proportion to the mean refraction.

sion) differs very markedly in the two cases, although the total length of the spectrum is the same in both.

The red is much contracted and the blue expanded with the glass prism. One can then have what might be called a mean refraction with the glass prism, the refraction of the individual groups of wave lengths not being in proportion to the lengths. Now it is from this irregularity of the refraction in different parts of the spectrum, and because the irregularity differs with different transparent substances,

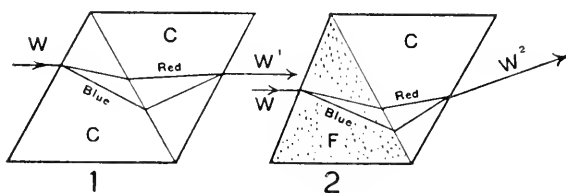

FIG. 172. ACHROMATISM BY COMBINING DIFFERENT KINDS OF GLASS.

(1) White light (W) traversing two equal crown glass (CC) prisms with their bases opposite. The dispersion into a spectrum by the first prism is overcome by the second prism and the light is recombined into a white beam (W^1), which is displaced as if it had traversed a piece of plane glass.

Red Blue The red and the blue edges of the spectrum. The blue is more refracted than the red.

(2) White light (W) traversing a flint glass prism (F) and being dispersed into the spectral colors. The spectrum formed by the flint prism is recombined by the crown glass prism (C), but the emerging ray of white light (W^2) is refracted markedly toward the base of the crown glass prism, showing the possibility of an achromatic image. The arrows show the direction in which the light is extending.

that it is possible to have the refraction necessary to produce images without having the light dispersed into colors at the same time. This is shown in fig. 172, 2, where a smaller prism of flint glass produces the same amount of dispersion as a larger prism of crown glass. If these prisms are with their edges opposite, the spectrum produced by the flint glass will be brought together by the crown glass and white light will result, but as the mean refraction of the larger crown glass prism is greater than that of the flint glass prism, the ray of white light will not extend parallel with the original direction, but be bent toward the base of the crown glass prism. As a lens may be considered an infinite number of prisms combined it becomes intelli-

gible from this how it is possible to produce colorless images by combining flint-glass concave and crown-glass convex lenses; or other pairs of lenses where the dispersion and refraction give comparable results.

In making the color corrections for the lenses, the spherical corrections were also made; the extent of both corrections attained up to the present is discussed below.

§ 465. Corrections in Achromatic and Apochromatic objectives. —

(1) Spherical aberration. In achromatic objectives the spherical

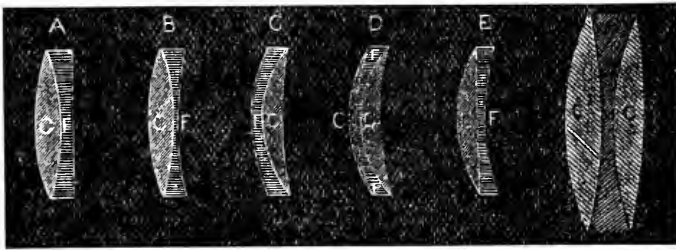

FIG. 173. ACHROMATIC COMBINATIONS OF CROWN AND FLINT GLASS LENSES.

(From Lewis Wright's Optical Projection).

C C C C C C Thin edge or converging crown glass lenses.

F F F F F F Thick edge or diverging flint glass lenses. The flint glass overcomes the dispersion without overcoming the mean refraction, hence all these combinations are converging.

aberration is corrected for one color only; in apochromatic objectives for two colors. (2) Chromatic aberration. In achromatic objectives correction is made for two colors; in apochromats for three colors.

In the apochromats it was found impossible to make the high corrections necessary even with all the new glasses made available by the Jena glass works; but with the new forms of glass and a natural mineral, fluorspar, fluorite, calcium fluoride, with its very low index of refraction and small dispersion, it was found possible to make the fundamental advance in microscope objectives represented by the apochromatic objectives.

The possibility of bringing three colors to one focus makes the apochromatic objectives especially valuable for photography. The

visual and actinic foci are coincident, and if the apparatus is well constructed there is never any difficulty in getting sharp pictures, for the photographic image is sharpest when it appears sharpest to the normal eye.

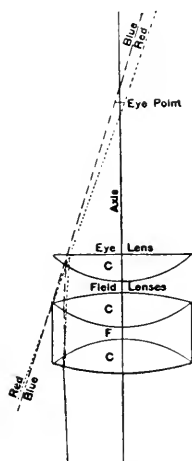

FIG. 174. POSITIVE COMPENSATION OCULAR.
(From Spitta, p. 110).

C F C The field-lens is composed of two double convex crown lenses and one double concave flint glass lens.

C The eye-lens is of crown glass, and is separated from the field combination the right distance to give the necessary excess magnification of the red image to make it balance the blue image which was over magnified by the objective.

Red Blue The red and blue rays limiting the image. It is seen here that the rays are not parallel but divergent, as they extend above the ocular. When projected by the eye to the virtual image the rays cross, throwing the red one to the outside, thus giving a larger image than is given by the blue ray, and the orange haze at the margin of the field when looking through the ocular toward the window or the sky.

§465a. It is interesting to note that the wonderful optical qualities of fluor-spar were known to Sir David Brewster, and recommended by him for aid in achromatization (Brewster's work on the microscope, 1837, p. 111); and before 1860 our own Charles A. Spencer used fluor-spar in one of the combinations of his objectives (Proc. Acad. Nat. Sci., Phila., Vol. LVI (1904), p. 475; Trans. Amer. Micr. Soc., 1901, p. 23)

§ 466. **Compensation oculars.** — As the front lens of objectives of high power (fig. 21, *B C*) is not a combination but a single lens,

aberrations are inevitably introduced which must be eliminated by a subsequent part of the optical train. The most striking and troublesome defect is the so-called difference of chromatic magnification;

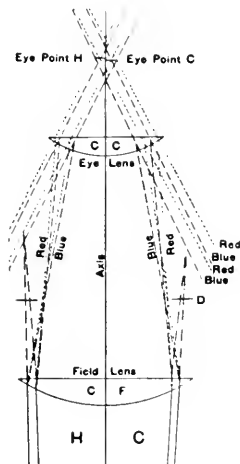

FIG. 175. HUYGENIAN OCULAR SHOWING THE ORDINARY AND THE COMPENSATING ACTION.

(From Spitta, p. 106).

Ordinary action. (H).

If the rays are traced on the left it will be seen that the field-lens (*C*) brings the rays to a focus at the diaphragm (*D*), and that they cross and pass on to the eye-lens slightly divergent, but in passing through the eye-lens (*C*), the red and blue constituents are made parallel to each other, and are projected into the field of vision in close parallel (virtual) bundles and hence appear achromatic.

Compensating action (C).

For this the field-lens is of flint glass (*F*), and the eye-lens of crown glass (*C*). Or the eye-lens may be an over-corrected combination. The end result is the same, viz., the red image is magnified more than the blue image by the ocular, and this balances the excess magnification of the blue image by the objective and in the projected (virtual) image the red is on the outside, producing the orange haze at the margin of the field when looking through the ocular, toward a window, or the sky.

that is, the differently colored constituent images forming the final image are of different magnitudes, the blue one being larger than the red one. This defect is more easily corrected in the ocular than in the subsequent combinations of the objective. The ocular is then

constructed to give a red image sufficiently large to bring its magnification up to that of the blue image, and hence the final image as seen by the eye is correct. The low power apochromats could be corrected for this, but for the sake of using the same oculars on all powers the defect is left or purposely introduced into all the apochromats. It will be seen from the above statement that for projection or for photography the apochromats cannot be used satisfactorily without the ocular to complete the corrections (see fig. 174-175).

The over-correction of the ocular necessary to give the greater magnification to the red constituent of the image leads to the position of the red on the outside of the projected (virtual) beam; hence in looking through a compensation ocular toward the window or the sky an orange haze appears around the margin. As the ordinary Huygenian ocular has an under-corrected eye-lens the blue constituent will be on the outside of the projected (virtual) image and there appears a blue haze around the edge of the field (Spitta, p. 112-113).

ANGULAR AND NUMERICAL APERTURE

§ 467. **Angular aperture.** — By this is meant the angle of light which passes from the object to the objective and becomes effective in producing the microscopic image (fig. 176). It has been known for a very long time that the clearness of the image, other things being equal, depends upon the width of the angle of light coming from the object; and that the resolution of details depended very largely upon the angular aperture of the objective. The difficulty of overcoming the aberrations also became greater as the angle was increased; and it was the triumph of the early American opticians, Spencer and Tolles, that they were able to make the corrections for high powers with very large angular aperture.

§ 468. **Numerical aperture.** — With the introduction of immersion systems into modern microscopy, it was seen and pointed out with great distinctness by Spencer and Tolles that the aperture of such immersion objectives might exceed 180° of light in air. For the average microscopist, however, this seemed an impossibility. By referring to fig. 158 to 160 the matter becomes very easily intelligible,

for it is seen that light in water in passing into air spreads out so that an angle in water of $48^{\circ} 45'$ on each side of the normal ($97^{\circ} 30'$) spreads out into an angle of 180° in air; therefore light at an angle of $97^{\circ} 30'$ in water is equal to 180° in air, and if the water immersion objective receives and transmits for the formation of the image an angle of light in the water greater than $97^{\circ} 30'$ its angle is greater than an air angle of 180° . In the same way with homogeneous immersion. The critical angle for glass to air is 41° on each side of the normal, and a total angle of 82° in the glass would spread out to form the whole 180° in the air. Therefore, if with homogeneous immersion objectives an angle above 82° is transmitted by the objective for the formation of the image, the angle is so much greater than 180° in air.

The confusion was reduced to order by Abbe, to whom makers and users of optical instruments owe so many debts. He applied the simple laws of trigonometry, using the sine function of the angle, and taking into consideration the medium of the lowest refractive index between the object and the objective. If it were air, unity was taken, if water the index of water — 1.33; if glass, 1.52; and if any other immersion fluid, the refractive index of that fluid. By thus considering the index of refraction of the medium immediately in front of the objective, it became possible to make comparisons which were rigidly exact, and expressed in terms which did not seem impossibilities like an angle in excess of 180° to enter a flat surface.

The nomenclature introduced by him and now universally employed is *Numerical Aperture*, and includes in its significance both the angle of the light and the index of refraction of the medium from which the light passes into the objective. The formula is $N.A. = n \sin u$, in which n is the index of refraction of the air for dry, the water for water immersion and the cedar oil for homogeneous im-

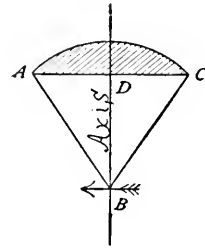

FIG. 176. ANGULAR APERTURE OF AN OBJECTIVE.

Axis, The principal optic axis of the objective.

B, The object just outside the principal focus.

ADC, Diameter of the front of the objective and base of the angle of aperture.

ADB, Half the angle of aperture (u); *AD* representing the sine of u (see § 468).

mersion; and u , is the sine of half the angle of the light entering the microscope objective, no matter what medium is between the object and objective.

As there are three factors in this formula, if one knows any two of them the third is readily found:

§ 469. *Table of a Group of Objectives with their Numerical Aperture with Method of Obtaining It. For a Table of Natural sines, see third page of cover.*

Objective	Angular Aperture ($2u$)	Natural Sine of half the angular aperture ($\sin u$).	Index of Refraction of the medium in front of the objective (n)	Numerical Aperture (N. A.) = $n \sin u$
25 mm. Dry.	20°	$\sin \frac{20^\circ}{2} = 0.1736$	$n = 1$	N.A. = $1 \times 0.1736 = 0.173$
25 mm. Dry.	40°	$\sin \frac{40^\circ}{2} = 0.3420$	$n = 1$	N.A. = $1 \times 0.3420 = 0.342$
$12\frac{1}{2}$ mm. Dry.	42°	$\sin \frac{42^\circ}{2} = 0.3584$	$n = 1$	N.A. = $1 \times 0.3583 = 0.358$
$12\frac{1}{2}$ mm. Dry.	100°	$\sin \frac{100^\circ}{2} = 0.7660$	$n = 1$	N.A. = $1 \times 0.7660 = 0.766$
6 mm. Dry.	75°	$\sin \frac{75^\circ}{2} = 0.6087$	$n = 1$	N.A. = $1 \times 0.6087 = 0.609$
6 mm. Dry.	136°	$\sin \frac{136^\circ}{2} = 0.9272$	$n = 1$	N.A. = $1 \times 0.9272 = 0.927$
3 mm. Dry.	115°	$\sin \frac{115^\circ}{2} = 0.8434$	$n = 1$	N.A. = $1 \times 0.8434 = 0.843$
3 mm. Dry.	163°	$\sin \frac{163^\circ}{2} = 0.9890$	$n = 1$	N.A. = $1 \times 0.9890 = 0.989$
2 mm. Water Immersion	$96^\circ 12'$	$\sin \frac{96^\circ 12'}{2} = 0.7443$	$n = 1.33$	N.A. = $1.33 \times 0.7443 = 0.99$
2 mm. Homogeneous Immersion	$110^\circ 38'$	$\sin \frac{110^\circ 38'}{2} = 0.8223$	$n = 1.52$	N.A. = $1.52 \times 0.8223 = 1.25$
2 mm. Homogeneous Immersion	$134^\circ 10'$	$\sin \frac{134^\circ 10'}{2} = 0.9211$	$n = 1.52$	N.A. = $1.52 \times 0.9210 = 1.40$

§ 470. **Significance of numerical aperture.** — It is now universally agreed that, the corrections in chromatic and spherical aberration being the same, the power to define minute details depends directly on the numerical aperture; the greater the numerical aperture the greater the resolution (see also § 475-476).

§ 471. **Why a homogeneous immersion condenser is required.** — If the definition of minute details requires adequate numerical aperture it is evident that it is of fundamental importance that the substage condenser be able to supply the light at the adequate aperture. Assuming that the substage condenser is properly constructed, the question is, can it illuminate the object with the proper numerical aperture?

By referring to § 468, and to figures 158-160, it is evident that an object mounted on a glass slide and separated from the condenser by a stratum of air can get light from the condenser only up to the critical angle, that is 41° , on each side of the normal, or a total of 82° , corresponding to a numerical aperture of 1. The objective may be capable, however, of receiving and utilizing a numerical aperture of 1.40.

If now the condenser also has a numerical aperture of 1.40 and it is connected to the slide by means of homogeneous immersion liquid the entire aperture will illuminate the object and can enter the homogeneous immersion objective.

If the substage condenser is connected with the slide by means of water, then, as shown in fig. 160, the object can be illuminated with an angle of $61^\circ + 61^\circ$ or 122° , or a numerical aperture of $n \sin u$; in this case $1.33 \times 0.875 = 1.1637$. If the greatest possible aperture is required, as in dark-ground illumination (§ 125), and for some of the most exacting work with photo-micrography and microscopic study, the condenser should be connected with the slide by homogeneous immersion liquid.

§ 472. **Determination of the aperture of objectives with an apertometer.** — Excellent directions for using the Abbe Apertometer may be found in the Jour. Roy. Micr. Soc., 1878, p. 19, and 1880, p. 20; in Dippel, Czapski and Spitta, Chapter XIV. The following directions are but slightly modified from Carpenter-Dallinger, pp. 394-396. The Abbe apertometer involves the same principle as that

of Tolles, but it is carried out in a simpler manner; it is shown in fig. 177. As seen by this figure it consists of a semicircular plate of glass. Along the straight edge or chord the glass is beveled at 45° , and near this straight edge is a small, perforated circle, the perforation being in the center of the circle. To use the apertometer the microscope is placed in a vertical position, and the perforated circle is put under the microscope and accurately focused. The circular edge of the apertometer is turned toward a window or plenty of artificial light so that the whole edge is lighted. When the objective

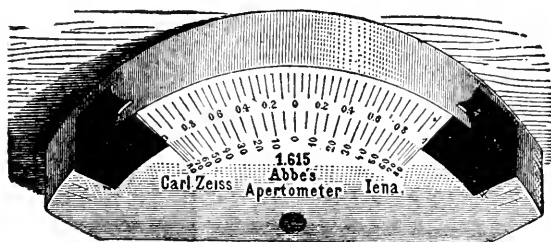

FIG. 177. ABBE APERTOMETER.

is carefully focused on the perforated circle the draw-tube is removed and in its lower end is inserted the special objective which accompanies the apertometer. This objective and the ocular form a low power compound microscope, and with it the back lens of the objective, whose aperture is to be measured, is observed. The draw-tube is inserted and lowered until the back lens of the objective is in focus, "In the image of the back lens will be seen stretched across, as it were, the image of the circular part of the apertometer. It will appear as a bright band, because the light which enters normally at the surface is reflected by the bevel part of the chord in a vertical direction so that in reality a fan of 180° in air is formed. There are two sliding screens seen on either side of the apertometer; they slide on the vertical circular portion of the instrument. The images of these screens can be seen in the image of the bright band. *These screens should now be moved so that their edges just touch the periphery of the back lens.* They act, as it were, as a diaphragm to cut the fan and reduce it, so that its angle just equals the aperture of the objective and no more."

“This angle is now determined by the arc of glass between the screens; thus we get an angle in *glass* the exact equivalent of the aperture of the objective. As the numerical apertures of these arcs are engraved on the apertometer they can be read off by inspection. Nevertheless a difficulty is experienced, from the fact that it is not easy to determine the exact point at which the edge of the screen touches the periphery of the back lens, or as we prefer to designate it, *the limit of aperture*, for curious as the expression may appear we have found at times that the back lens of the objective is *larger* than the *aperture* of the objective *requires*. In that case the edges of the screen refuse to touch the periphery.”

In determining the aperture of homogeneous immersion objectives the proper immersion fluid should be used as in ordinary observation. So, also, with glycerin or water immersion objectives.

§ 473. **Testing Homogeneous Immersion Liquid.** — In order that one may realize the full benefit of the homogeneous immersion principle it is necessary that the homogeneous immersion liquid shall be truly homogeneous. In order that the ordinary worker may be able to test the liquid used by him, Professor Hamilton L. Smith devised a tester composed of a slip of glass in which was ground accurately a small concavity and another perfectly plain slip to act as cover. (See Proc. Amer. Micr. Soc., 1885, p. 83.) It is readily seen that this concavity, if filled with air or any liquid of less refractive index than glass, acts as a concave or dispersing lens. If filled with a liquid of greater refractive index than glass, the concavity acts like a convex lens, but if filled with a liquid of the same refractive index as glass, that is, liquid optically homogeneous with glass, then there is no effect whatever.

In using this tester the liquid is placed in the concavity and the cover put on. This is best applied by sliding it over the glass with the concavity. A small amount of the liquid will run between the two slips, making optical contact on both surfaces. One should be careful not to include air bubbles in the concavity. The surfaces of the glass are carefully wiped so that the image will not be obscured. An adapter with society screw is put on the microscope and the objective is attached to its lower end. In this adapter a slot is cut out of the right width

and depth to receive the tester which is just above the objective. As object it is well to employ a stage micrometer and to measure carefully the diameter of the field without the tester, then with the tester far enough inserted to permit of the passage of rays through the glass but not through the concavity, and finally the concavity is brought directly over the back lens of the objective. This can be easily determined by removing the ocular and looking down the tube.

Following Professor Smith's directions it is a good plan to mark in some way the exact position of the tube of the microscope when the micrometer is in focus without the tester, then with the tester pushed in just far enough to allow the light to pass through the plane glass, and finally when the light traverses the concavity. The size of the field should be noted also in the three conditions (§ 47-49).

It is seen by glancing at the following table that whenever the liquid in the tester is of lower index than glass, the concavity with the liquid acts as a concave lens, or in other words like an amplifier (§ 236a), and the field is smaller than when no tester is used. It is also seen that as the liquid in the concavity approaches the glass in refractive index, the field approaches the size when no tester is present. It is also plainly shown by the table that the greater the difference in refractive index of the substance in the concavity and the glass, the more must the tube of the microscope be raised to restore the focus.

If a substance of greater refraction than glass is used in the tester the field is larger, *i. e.*, the magnification less, and one would have to turn the tube down instead of up to restore the focus.

The table given below indicates the changes when using a tester prepared by the Gundlach Optical Co., and used with a 16 mm. apochromatic objective of Zeiss, $\times 4$ compensation ocular, achromatic condenser, 1.00 N. A. (fig. 40):

§ 474. Diffracted light in microscopy. — As most microscopic observation depends upon directed light from some source like the sun or a lamp sent to and through the object by a mirror only or by the aid of a condenser or a mirror and condenser, the phenomena of diffraction are present. It is evident that if the objects observed were self-luminous the conditions would be different from those existing

Tester and Liquid in the Concavity	Size of the Field	Elevation of the Tube necessary to Restore the Focus
No tester used.....	1.825 mm....	Standard position
Whole thickness of the tester at one end, not over the cavity	1.85 mm.....	No change of focus.
Tester with water.....	1.075 mm....	Tube raised $3\frac{1}{2}$ mm.
Tester with 95% alcohol.....	1.15 mm.	3 mm.
Tester with kerosene.....	1.4 mm.....	2 mm.
Tester with Gundlach Opt. Co.'s hom. liquid.....	1.825 mm....	$\frac{1.0}{1.00}$ mm.
Bausch & Lomb Opt. Co.'s hom. liquid.....	1.825 mm....	$\frac{2.0}{1.00}$ mm.
Leitz' hom. liquid.....	1.825 mm....	$\frac{2.0}{1.00}$ mm.
Zeiss' hom. liquid.....	1.825 mm....	$\frac{2.0}{1.00}$ mm.

when the object must be viewed with direct light from some outside source.

In traversing small orifices or slits and objects with minute details the spreading out of diffracted light is a necessary accompaniment. The diffracted rays are shown by broken lines in the accompanying figures from Wright (fig. 178-179). As seen from these there may be two systems of diffracted rays, one from the object and another from the border of the objective, and these two systems of diffracted rays act differently.

The rôle played by the diffracted light has been variously interpreted by opticians. By Abbe and his adherents diffracted light is of supreme importance, and microscopic vision is a thing by itself (sui generis) and not to be interpreted by ordinary geometric optics. Certain very striking experiments have been devised to show the accuracy of this hypothesis, but as pointed out by many, the ordinary use of the microscope never involves the conditions realized in those experiments.

While the supreme importance ascribed by some to the diffracted light may not be accepted, no one will deny the presence of diffraction phenomena in microscopic vision. If, furthermore, the diffracted rays are brought by the microscope to the final focus with the undiffracted light passing from the object through the microscope, the image will be conceivably more perfect than as if the diffracted rays produce secondary images, or mere blur.

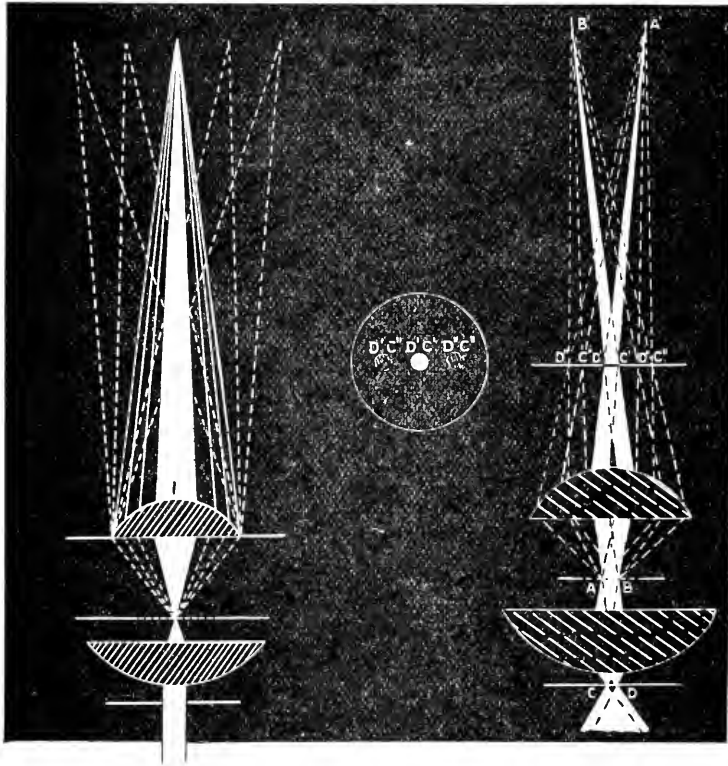

FIG. 178-179. DIFFRACTED LIGHT IN MICROSCOPY.

(From Wright's Principles).

Fig. 178. Object (grating) lighted with a narrow beam (*I*) from the condenser and giving off diffracted rays which are brought to a focus with the dioptric beam (*I*) above the objective in part (full lines); and in part forming diffracted beams on each side above the objective (broken lines). These diffracted beams not brought to the same focus as the dioptric beam cause imperfections or confusion in the image.

Fig. 179. Small diaphragm (*CD*) below the condenser focused on the grating, *AB*, and from this point the dioptric beam (solid white) and diffracted light (broken lines) extend through the objective and finally focus at *B'A'*. By looking at the eye-point with a magnifier the image of the back lens shows not only the diaphragm image (*D'C'*), but secondary images of the same (*D''C''* and *D'''C'''*). See small figure in the middle also.

§ 475. **Depth of focus and aperture.** — It is known to all workers with the microscope that with objectives of low aperture it is possible to change the focus rather markedly up or down without seeming to lose in sharpness, while with objectives of great aperture a sharp focus is almost immediately lost in focusing up or down beyond a point. The reason for this is made strikingly evident by fig. 180 (1, 2). Let f be the most perfect focus, if one turns to a or b the appearance is almost unchanged in the low apertured objective (2), but the diffusion circle is very marked in the high apertured objective (1). Furthermore, the brilliancy of the image must be markedly greater with the larger aperture (Wright, p. 77).

§ 476. **Aperture and the effect of opacities.** — Between the retina and the object there are many possibilities of opacities in the image-producing beam of light. For example, the eye lashes, particles of dirt in the tears over the cornea, besides particles on the glass surfaces. Figure 180 (3, 4, 5) show graphically the relative obscuration which must result with the same opacity in beams of different aperture. In (3) the shadow is so great that almost the entire aperture is obscured, and vision made difficult or impossible. In (4) with a larger aperture the shadow is not so overwhelming, and in (5) with the large aperture there is still possibility of fairly good vision in spite of the shadow.

It is believed that the inevitable narrowing of the beam in high power magnification and the presence of opacities in the eye form the bar to resolution, and that if the apparatus and the eye could, on the one hand, be free from opacities to throw shadows and thus obscure the image, or on the other hand the terminal beam could be opened up to make the aperture greater, the eye could discriminate beyond the limits heretofore ascribed to it (Wright, Ch. XVI).

As the higher the power of the ocular the smaller is the eye-point (fig. 23-24), it is evident that any obscurities have a greater effect with the high ocular. The rule to use as low an ocular as possible is a good one to follow from every standpoint (Wright, p. 227).

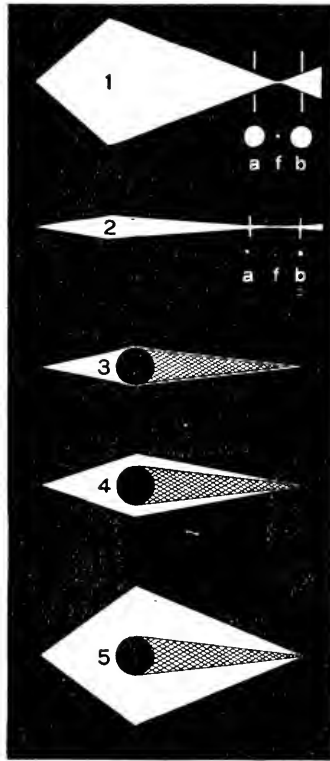

FIG. 180. EFFECT OF APERTURE ON DEFINITE FOCUS AND ON OVERCOMING OPACITIES.

(From Wright's Principles of Microscopy, p. 77).

(1) To show the definiteness of the focus (f) with a large aperture. Either above or below this is a large diffusion circle ($a\ b$) due to the size of the section of the aperture.

(2) Indefiniteness of the focus due to the fact that a cross section of the aperture considerably above or below the true focus (f), gives so small a diffusion circle (a or b), that it can hardly be distinguished from the true focus.

(3) Low aperture and an opacity in the path of the light. It is so large relatively here that a clear image would be impossible.

(4) The same opacity in a larger aperture.

(5) The same opacity in a still larger aperture. There is now enough of the beam outside the opacity to make the object visible.

INDEPENDENT MAGNIFICATION OF OBJECTIVES AND OCULARS

§ 477. Independent magnification of an objective. — The independent magnification of an objective is like that of a simple micro-

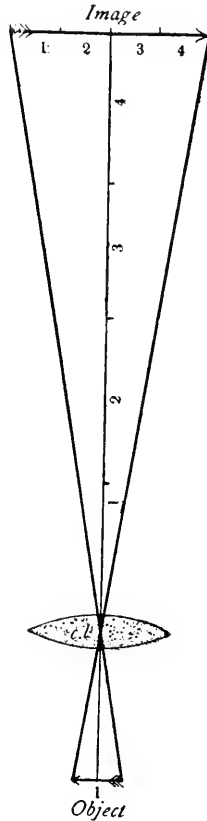

FIG. 181. REAL IMAGE SHOWING THAT THE SIZE DEPENDS UPON THE RELATIVE DISTANCE OF OBJECT AND IMAGE FROM THE CENTER OF THE LENS.

Object The object of which an image is to be formed.

c Center of the lens.

1 This shows that the object is 1 unit long and its distance from the center of the lens is also 1.

1 2 3 4 The image is 4 units distant from the center of the lens, and the image is consequently 4 units long.

scope or it is like that of a projection microscope when the objective alone is used (fig. 181, 182). As pointed out in § 236 it is necessary to select some standard distance for the projection of the real or of

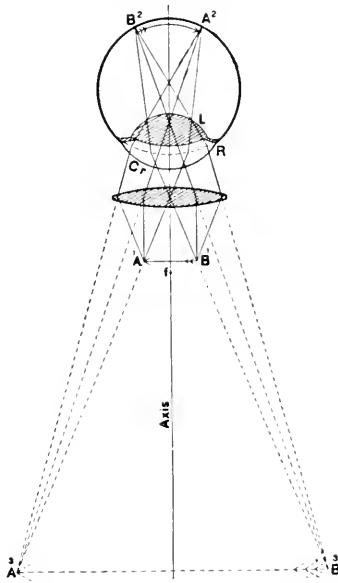

FIG. 182. PROJECTED VIRTUAL IMAGE OF A MAGNIFIER.
(Simple Microscope or Ocular).

The projection distance is 250 mm. from the nodal point in the crystalline lens of the eye.

Axis The optic axis of the magnifier and of the eye.

A¹ B¹ The object of the simple microscope or real image of the objective.

B² A² The retinal image (inverted).

A³ B³ The projected virtual image. It is erect as compared with the object, but inverted as compared with the retinal image.

Cr. Cornea of the eye.

R Single refractive surface of the schematic eye.

L Crystalline lens of the eye.

the virtual image, for the size of the image varies directly as its distance from the center of the lens (fig. 181 for real and 182 for virtual images; in the latter the projection distance is from the nodal point in the eye to the image). The image distance for magnification most commonly employed is 250 mm. (§ 236).

To find the magnification of any objective at this image distance one can proceed as for the simple microscope, but the better method is by the use of the ocular micrometer. Two micrometers of known value are needed, — a stage micrometer and an ocular micrometer in divisions of a millimeter.

(A) Determination of the magnification with a Huygenian ocular with fixed or movable scale (fig. 91). Remove the field-lens and focus the ocular micrometer lines by raising or lowering the eye-lens. Focus the stage micrometer lines, and make the lines of the two micrometers parallel. Make the lines of the two coincide. Suppose the image of 0.2 mm. on the stage micrometer covered 2mm. on the ocular micrometer, the magnification in this case would be 2mm. divided by 0.2 mm. = 10. One could also use the filar micrometer as directed in § 243. A positive ocular has the advantage that nothing needs to be changed in it.

(B) Effect of the field-lens. For getting the independent magnification of the objective the field-lens of the Huygenian ocular must be removed, but for determining the magnification of the objective when used with the field-lens in position as in ordinary observation, reinsert the field-lens and determine the magnification of the combined objective and the field-lens exactly as directed above. One can tell in this way also how much the magnification of the ocular is reduced by the field-lens. It is very marked (fig. 23-24, 183).

(C) Effect of tube-length. The effect of tube-length on the magnification of the objective is discussed in § 236. The general law is that with a given lens or combination the more distant from the lens the image is formed the greater is the magnification; therefore in every case the conditions must all be made exactly alike if the results are to be similar. This is easily proved by getting the magnification of the objective on the ocular micrometer with a tube-length of 160 mm. and then with 250 mm. If one has a projection microscope the difference is strikingly shown by using an objective alone and getting the magnification at a screen distance of 1 meter and then at 2 meters. The magnification will be almost exactly twice as great at 2 meters as at one meter. The same holds for the projected virtual image, as one can see by fig. 85 and 182.

§ 478. **Magnification due to the ocular.** — To find this experimentally use a positive ocular with an ocular micrometer or a filar micrometer, or remove the field-lens of the Huygenian ocular in which is present an ocular micrometer. Make the tube-length 160 or 250 mm. Focus the stage micrometer on the ocular micrometer and see what the objective magnification is. For example, suppose the objective real image of $\frac{1}{10}$ mm. covers 2 mm. on the ocular micrometer, the

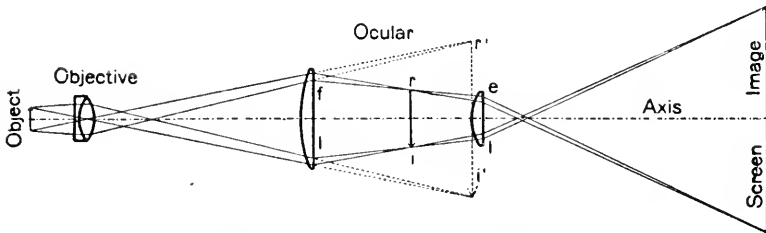

FIG. 183. DIAGRAM SHOWING THE RAYS AND IMAGES WHEN BOTH AN OBJECTIVE AND AN OCULAR ARE USED.

(From Optic Projection).

Object The object of which an image is desired.

Objective The optical combination forming the first image.

Ocular Huygenian ocular projecting the screen image.

f l Field-lens diminishing the real image of the objective from $r' i'$ to $r i$.

r i Real image produced by the objective and the field-lens.

$r' i'$ This would be the size of the real image if no field-lens were used.

e l Eye-lens serving to project the real image ($r i$) to the screen.

Screen Image The real image on the screen projected by the eye-lens.

Used in the ordinary way with the eye next the ocular a virtual image is projected (fig. 78, 182).

magnification in that case is 20. Now use the Wollaston camera lucida and project the virtual image 250 mm. and get the magnification of the entire microscope as directed in § 234. Suppose it is 200 diameters. It is known that the objective magnifies 20 diameters and to get 200 diameters there must be a second or ocular magnification of $200 \div 20 = 10$. That is, the ocular in this case magnifies the objective real images 10 diameters, making the magnification of the microscope as a whole $20 \times 10 = 200$.

This was without the field-lens. Put the field-lens in place and get the magnification of the entire microscope again. It will be markedly

less, as the field-lens makes the objective image smaller (fig. 23-24, 183). In the case in hand the reduction of the objective image was $\frac{1}{4}$, so that the real image of the objective with the field-lens in place was 15 diameters, and of the whole microscope then only 150 diameters, as the magnification of the eye-lens is unchanged. But as the objective is not changed in power by the field-lens, the effect of the entire ocular, field- and eye-lens, must be the entire magnification of the microscope divided by the power of the objective, which is 20 diameters. $150 \div 20 = 7.5$. In this case then the ocular as a whole magnifies the real image of the objective (20) 7.5 times. In all Huygenian oculars, then, the field-lens acts as a reducing lens, the eye-lens as a magnifier, and this is true whether the microscope is used as in ordinary observation (fig. 23-24) or for projection (fig. 183).

§ 479. **Magnification of drawings.** — In determining the magnification of a drawing made with a camera lucida or with projection-apparatus, by far the best method of determining it is to remove the specimen and put in its place a stage micrometer and project the image of the micrometer upon the drawing paper. Make a few lines of the micrometer image and indicate the value of the spaces (fig. 103), then at any time one can determine exactly what the magnification is (§ 276).

§ 480. **Par-focal Oculars.** — By this is meant oculars of different power in which the microscope remains in focus on changing the oculars.

As originally constructed the microscope had to be focused every time the oculars were changed. Mr. Edward Penneck, in seeking to overcome this inconvenience, wrote to Professor Abbe for advice in 1881. After successfully producing oculars of different powers for the Acme microscopes of James W. Queen & Co., according to the directions given by Professor Abbe, Mr. Penneck, as editor of the *Microscopical Bulletin and Science News*, published in Vol. III, 1886, pp. 9-10, the following, with Professor Abbe's letter: "Changing Eye-pieces without altering Focus," etc. "Some years ago the writer, in looking up certain questions in connection with eye-pieces, took occasion to write to Professor Abbe, and his reply, kindly given, is so clear and to the point, and of such interest and value, that we take the liberty of publishing it for the benefit of our readers."

"JENA, June 25th, 1881. Dear Sir: The question which you ask admits of a simple answer: In order to change the oculars of a microscope without changing the focus of the objective, neither the diaphragm nor the field-lens must come to the same place in the microscope tube, but the anterior (lower) focal points of the ocular systems must do this. In the case of a Huygenian eye-piece, the said anterior focus is a virtual one situated above the field-lens at a place D^x , which

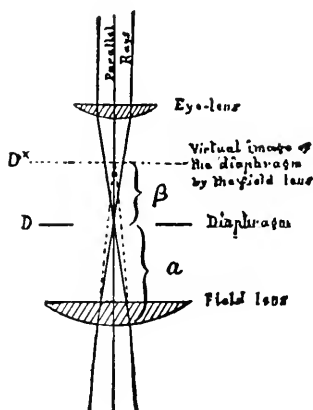

FIG. 184. PAR-FOCALIZATION OF OCULARS.

(From the Microscopical Bulletin, 1886).

is more distant from the field-lens than the diaphragm D . The level of D^x is the place where the virtual image of the diaphragm appears to an observer looking through the field-lens. Rays which are required to emerge from the eye-lens as parallel rays (or nearly parallel) must of course enter into the ocular converging to the point D^x . Consequently, if different oculars are inserted successively in such a way that the point D^x comes to the same place of the tube always, the conjugate foci of object and image in the objective remain unaltered.

"This arrangement and no other one fulfills at the same time the other request that the amplification of the microscope with different oculars should be in exact inverse proportion of the equivalent focal length of the oculars.

"The position of the point D^x may be easily calculated for every ocular. If a is the distance of the diaphragm from the field lens and X the focal length of that lens, the distance of the focus D^x above the diaphragm (*i.e.* the distance from D to D^x) will be: $\beta = \frac{a}{X-a}$.

Hoping that these explanations will be found satisfactory for your aim, I remain

Yours sincerely,

DR. E. ABBE."

On page 31 of the Bulletin is the following: "Par-focal Eye-pieces. Referring to the article in the April issue of the Bulletin, on changing eye-pieces without altering focus, etc., we announce that we are prepared to furnish eye-pieces as here described with our Acme microscopes at a slight additional expense.

"We have named these eye-pieces *Par-focal*, meaning of equal focus, from the Latin *par* (equal) and *focus*."

For the par-focalization of objectives, see § 74-75.

COLLATERAL READING FOR CHAPTER IX

Optic Projection, S. H. & H. P. Gage.

Principles of Microscopy, Sir. A. E. Wright.

Microscopy, E. J. Spitta.

The Microscope and its Revelations, Carpenter-Dallinger.

Journal of the Royal Microscopical Society.

Transactions of the American Microscopical Society, especially the address of Hon. J. D. Cox, 1884, pp. 5-39 on Aperture, and 1893, pp. 1-16, and A. C. Mercer, 1896, pp. 321-396.

C. W. Woodworth, A. New Fundamental Equation in Optics. *Science*, N. S. Vol. XLIII, pp. 824-825.

John C. Shedd, The Index of Refraction. *School Science and Mathematics*, Vol. VI., 1906, pp. 678-680.

(This article gives a brief history of the discovery of the law of refraction; it also discusses the ratio of velocities in different media, and shows that the coefficient of retardation of velocity in a transparent medium is the reciprocal of the index of refraction.)

CHAPTER X

SLIDES AND COVER-GLASSES; MOUNTING; ISOLATION; LABELING AND STORING MICROSCOPIC PREPARATIONS; REAGENTS

§ 485. Apparatus and material for Chapter X. —

1. Glass slides for mounting microscopic objects (fig. 185-187).
2. Cover-glasses for covering mounted objects (fig. 185-187).
3. Glass dishes for storing slides and covers (§ 492).
4. Cleaning mixtures for slides and covers (§ 488, 492, 497).
5. Micrometer calipers and measurer for slides and covers (fig. 188, 189).
6. Anatomical instruments, forceps, scissors, scalpels, needles.
7. Turn-table for sealing cover-glasses and making cells (fig. 191).
8. Centering card (fig. 192).
9. Moist chamber (fig. 199).
10. Balsam, glycerin jelly and shellac bottles (fig. 194-195).
11. Glass vials for preparations (fig. 196-197).
12. Block with holes for supporting vials (fig. 198).
13. Watch glasses.
14. Labels and catalogue card (§525-526).
15. Cabinets and trays for microscopic objects (fig. 204-208).
16. Lockers for specimens (fig. 208).
17. Measuring and weighing apparatus (fig. 209. § 536).
18. Bottles for containing the various reagents.
19. Pipettes and simple microscopes (fig. 200-202).
20. Fixing, imbedding, dissociating, mounting and staining agents (§ 534-592).
21. Mounting media (balsam, glycerin jelly, etc.) (543-547).

§ 486. Slides, glass slides or slips, microscopic slides or slips. —

These are strips of clear flat glass upon which microscopic specimens are usually mounted for preservation and ready examination. The size that has been almost universally adopted for ordinary preparations is 25×76 millimeters (1×3 inches). For rock sections, slides 25×45 mm. or 32×32 mm. are used; for serial sections, slides 25×76 mm., 38×76 mm. or 50×76 mm. are used. For special purposes, slides of the necessary size are employed without regard to any conventional standard.

Whatever size of slide is used, it should be made of clear glass and the edges should be ground. It is altogether false economy to mount permanent microscopic objects on slides with unground edges. It is unsafe also, as the unground edges are liable to wound the hands.

Thick slides are preferred by many to thin ones. For micro-chemical work Dr. Chamot recommends slides of half the length of

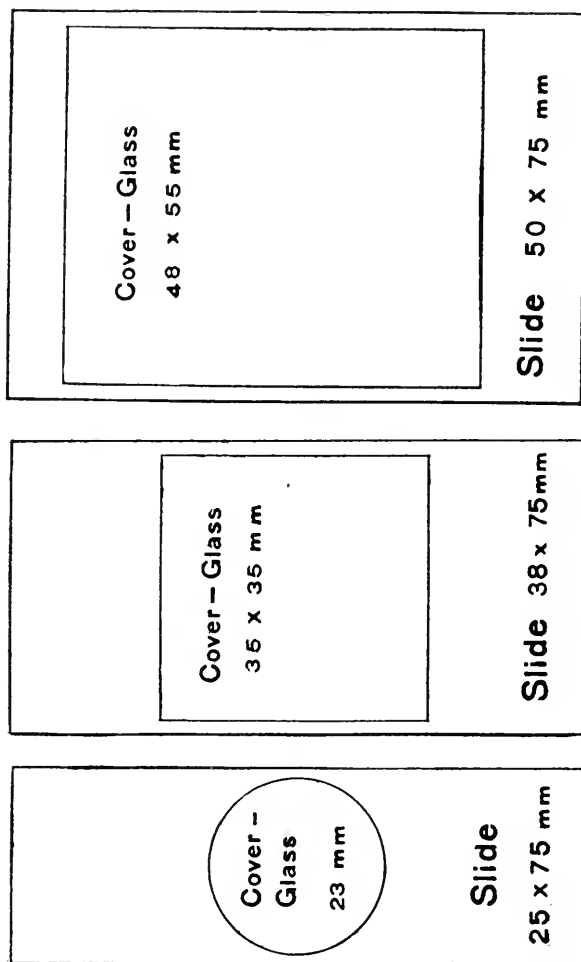

FIG. 185, 186, 187. STANDARD SIZES OF GLASS SLIDES FOR MOUNTING MICROSCOPIC PREPARATIONS.

those used in ordinary microscopic work. From the rapidity with which they are destroyed, he thinks the ground edges are unnecessarily expensive. He adds further: "It is a great misfortune that the

colorless glass slips used in America and so excellent for ordinary microscopic work should be easily attacked by all liquids; even water extracts a relatively enormous amount of alkalis and alkaline earths. The slips of greenish glass, while not as neat or desirable for general microscopy, seem to be decidedly more resistant, and are therefore preferable." Transparent celluloid slides are recommended by Behrens for work where hydrofluoric acid and its derivatives are to be examined. (Chamot, *Jour. Appl. Micr.*, vol. iii, p. 793. *Chemical Microscopy*, p. 123-124).

§ 487. **Thickness of slides for special purposes.** — It is very important to observe strictly the requirements for the thickness of slide for special purposes. As pointed out in discussing the dark-ground condenser (§ 125-127), the slide must be thin enough so that the focus of the condenser will be just above the upper surface where the object is mounted. If the slide is too thick the focus will be beneath the object and the best light cannot be obtained. So likewise with the best achromatic condensers, especially when used as homogeneous immersion condensers (§ 471), if the slide is too thick the focus of the condenser will fall below the object and the best and most critical images cannot be obtained.

It is better to use a slide thinner than the maximum permissible and plenty of homogeneous liquid between the slide and the condenser, then the condenser can be lowered until its focus is upon the object. This applies equally with the dark-ground condenser. For getting the thickness of the slides, use the micrometer calipers or the cover-glass measurer (fig. 188-189).

§ 488. **Cleaning slides for ordinary use.** — Place new slides that are to be wiped at once in a glass vessel of distilled water containing 5% ammonia. For wiping the slides use a lintless towel or a well-washed linen towel. One may avoid large wash bills by using absorbent gauze (§ 488a).

In handling the slides grasp them by the edges. Cover the fingers of the right hand with the wiping towel or the gauze and rub both faces with it. When wiped thoroughly dry, place the slide in a dry glass jar or for larger numbers use a museum jar (fig. 214). Soap and water are also recommended for new slides.

Alcohol of 50% to 82% is also excellent for cleaning new slides, and for slides which have been freed from mounting media by boiling (§ 489) after a thorough rinsing in clean water.

§ 488a. **Absorbent gauze and lintless towels.** — The gauze mentioned is No. 10, "*Sterilized absorbent gauze*," of the Griswoldville Mfg. Co. of New York. It is sometimes called bleached cheese cloth. In the author's laboratory it is cut into pieces, $\frac{1}{4}$, $\frac{1}{8}$, $\frac{1}{16}$ of a yard. When a piece is soiled it is thrown away. There has recently appeared specially prepared towels for wiping glass etc., which are called "lintless," as practically no lint is left on the wiped object. These are furnished by Johnson & Johnson of New York, and cost about 15 cents each in a size 42×90 cm.

§ 489. **Cleaning used slides.** — If only watery substances or glycerin or glycerin jelly have been used one may soak the slides overnight in ammonia water, then change the water for fresh and wipe as described in § 488.

When balsam or other resinous media (§ 543) have been used it is best to heat the slides over a Bunsen flame and remove the cover-glass. Place the covers in cleaning mixture (§ 497). The slide may also be placed in cleaning mixture or in some hot water containing 10% gold dust or other strong alkaline cleaner. When the metal basin — preferably an agateware basin — is two-thirds full of the slides, heat until the water comes to a boil. Then let it cool. Add fresh water and most of the slides may be wiped clean.

If dichromate cleaning mixture is used the best method is to have a museum jar of it and drop the slides in as they are rejected, or a large number at once, as is most convenient. It may require a week or more to clean the slides with cleaning mixture. As this is a very corrosive mixture for metals use only glass dishes in dipping into it. When the slides are freed from balsam, etc., pour off the cleaning mixture into another glass vessel and allow a stream of water to flow over the slides until all the cleaning mixture has been washed away. Then add distilled water and wipe the slides from that. Any slides still not freed from the balsam should be put back into the cleaning mixture. Apparently the slides are not injured by a prolonged stay in the mixture.

§ 490. **Cleaning slides for special uses.** — In making blood films, for micro-chemistry and whenever an even film is desired every particle

of oily substance must be removed. The slides should be placed in the dichromate cleaning mixture (§ 497) one day or more, thoroughly washed with clean water and then in distilled water, or in 50% to 75% alcohol. They are taken from the water or alcohol and wiped dry as needed. In wiping keep two or more layers of the absorbent gauze over the fingers. Only one slide is wiped with each piece of gauze. The surface to touch the slides should never have been touched by the hands, for a minute amount of oily substance leaves a stratum on the slide which causes the liquids used to heap up instead of flowing out perfectly flat. That is, the slide is wet with difficulty and the liquid instead of forming a film tends to assume the spheroidal state. Sometimes new gauze or other cloth used may not be wholly free from oily substance, or the soap was not wholly eliminated in washing. Such wiping cloths will not make the slides ready for good films. Some workers soak the gauze in sulphuric ether to remove the last traces of oily substance. This is done more especially in cleaning cover-glasses for films (see below). Burnett, p. 22, in speaking of blood smears, says: "The slides should be thoroughly clean. Unused slides may be cleaned in strong soap or 'gold dust' solution well rinsed in water, then placed in alcohol from which they are wiped and polished."

As intimated above, the best way to tell when slides or covers are free from a surface film is to drop some water on the surface and then hold the slide or cover nearly vertical. If the surface is clean the water will run over the slide, leaving a smooth wet track. If a film of oily substance is present the water will crawl and form ridges or droplets and not leave a smooth wet surface. Sometimes it is almost impossible to get a slide so that a smooth, even film of blood or other liquid can be made upon it. According to Chamot (p. 124), such slides may be rendered suitable for use, in many cases, by passing them slowly through the Bunsen flame. Cover-glasses are also rendered usable by the same method when they are refractory after wiping carefully.

§ 491. **Cover-glasses or covering glasses.**—These are circular or quadrangular pieces of thin glass used for covering and protecting microscopic objects. They should be very thin, 0.12 to 0.25 milli-

meter. It is better never to use a cover-glass over 0.20 mm. thick, then the preparation may be studied with a 2 mm. oil immersion as well as with lower objectives. Except for objects wholly unsuited for high powers, it is a great mistake to use cover-glasses thicker than the working distance of a homogeneous objective (§ 76). Indeed, if one wishes to employ high powers, the thicker the section the thinner should be the cover-glass.

The cover-glass should always be considerably larger than the object over which it is placed.

§ 492. **Cleaning cover-glasses for ordinary use.** — Covers may be cleaned well by placing them in 82% or 95% alcohol containing hydrochloric acid one per cent. They may be wiped almost immediately.

Remove a cover from the alcohol, grasping by the edge with the left thumb and index. Cover the right thumb and index with some clean gauze or other absorbent cloth; grasp the cover between the thumb and index and rub the surfaces, keeping the thumb and index well opposed on directly opposite faces of the cover so that no strain will come on it, otherwise the cover is liable to be broken.

When a cover is dry hold it up and look through it toward some dark object. The cover will be seen partly by transmitted and partly by reflected light, and any cloudiness will be easily detected. If the cover does not look clear, breathe on the faces and wipe again. If it is not possible to get a cover clean in this way it should be put again into the cleaning mixture.

As the covers are wiped put them in a clean shellvial (fig. 196), glass box or Petri dish. Handle them always by their edges, or use fine forceps. Do not put the fingers on the faces of the covers, for that will surely cloud them.

§ 493. **Cleaning cover-glasses for special uses.** — As with slides, covers intended for films or other purposes where the least particles of oily substance must be removed, are best put one by one into dichromate cleaning mixture (§ 497). After a day or more this is poured off and a stream of fresh water allowed to run on the covers until all the cleaning mixture is removed. Then distilled water is added and allowed to stand a few minutes. This is poured off and 82% or 95%

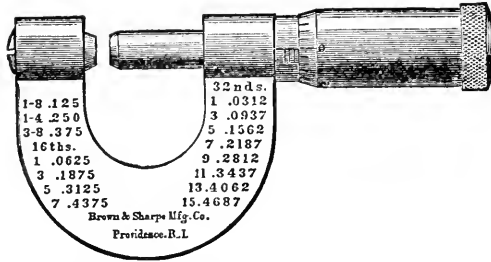

FIG. 188. MICROMETER CALIPERS FOR MEASURING THE THICKNESS OF SLIDES AND COVER-GLASSES.

(From the Catalogue of the Brown & Sharpe Manufacturing Company).

able of receiving a smooth and even film of blood or other aqueous liquid.

§ 494. **Cleaning large cover-glasses.** — For serial sections and especially large sections, large quadrangular covers are used. These are to be put one by one into a cleaning mixture as for the smaller covers and treated in every way the same. In wiping them one may proceed as for the small covers, but special care is necessary to avoid breaking them. It is desirable that these large covers should be thin — not over 0.15–0.20 mm., otherwise high objectives cannot be used in studying the preparations.

§ 495. **Measuring the thickness of cover-glasses.** — It is of great advantage to know the exact thickness of the cover-glass on an object; for, (a) in study-

alcohol added. The covers remain in this until needed. In wiping use the precautions given with slides (§ 490).

Test for the proper cleanliness as for slides (§ 490), and remember the advantage of heating the cover-glass in a Bunsen or alcohol flame to render it cap-

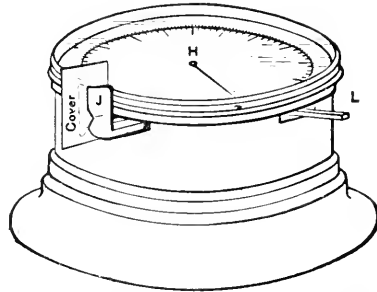

FIG. 189. MEASURER FOR SLIDES AND COVER-GLASSES.

(Modified from the figure in Zeiss Catalogue).

Cover A cover-glass between the jaws (*j*).
J Jaws between which the object to be measured is placed.

H Hand which points to the graduations on the face indicating the fractions of a millimeter or inch that represents the thickness of the object between the jaws.

L Lever by which the jaws are opened to receive the object.

ing the preparation one would not try to use objectives of a shorter working distance than the thickness of the cover (§ 76); (b) in using adjustable objectives with the collar graduated for different thicknesses of cover, the collar can be set at a favorable point without loss of time; (c) for unadjustable objectives the thickness of cover may be selected corresponding to that for which the objective was corrected (§ 460). Furthermore, if there is a variation from the standard, one may remedy it, in part at least, by lengthening the tube if the cover is thinner, and shortening it if the cover is thicker than the standard (§ 462).

Among the so-called No. 1 cover-glasses of the dealers in microscopical supplies, the writer has found covers varying from 0.10 mm. to 0.35 mm. To use cover-glasses of so wide a variation in thickness without knowing whether one has a thick or thin one is simply to ignore the fundamental principles by which correct microscopic images are obtained.

From information supplied by Mr. Edward Pennock the thickness of various cover-glasses should be within the following limits:

No. 1 cover-glasses....0.12 to 0.18 mm.

No. 2.....0.18 to 0.25 mm.

No. 3.....0.25 to 0.50 mm.

No. 0.....0.10 mm. slightly more or less.

In general cover-glasses thinner than the minimum (0.12 mm.) of No. 1, actual measurement, will, as stated above, usually show a much wider variation.

It is then strongly recommended that every preparation shall be covered with a cover-glass whose thickness is known, and that this thickness be indicated in some way on the preparation.

§ 496. Cover-glass measures, testers, or 'gauges. — For the purpose of measuring cover-glasses there are two very excellent pieces of apparatus. The micrometer calipers (fig. 188), used chiefly in the mechanic arts, are convenient and from their size are easily carried in the pocket. The cover-glass measurer specially designed for the purpose is shown in fig. 189, by which covers may be more rapidly measured than with the calipers.

With these measures or gauges one should be certain that the index stands at zero when at rest. If the index does not stand at zero it should be adjusted at that point, otherwise the readings will not be correct.

As the covers are measured, the different thicknesses should be put into different glass boxes and properly labeled. Unless one is striving for the most accurate possible results, cover-glasses not varying more than 0.06 mm. may be put in the same box. For example, if one takes 0.15 mm. as a standard, covers varying 0.03 mm. on each side may be put into the same box. In this case the box would contain covers of 0.12, 0.13, 0.14, 0.15, 0.16, 0.17, and 0.18 mm.

§ 497. **Dichromate cleaning mixture for glass.**—The cleaning mixture used for cleaning slides and cover-glasses is that commonly used in chemical laboratories: (Dr. G. C. Caldwell's Laboratory Guide in Chemistry).

Dichromate of potash ($K_2Cr_2O_7$).....	200 grams
Water, distilled or ordinary.....	800 cc.
Sulphuric acid (H_2SO_4).....	1200 cc.

As great heat is developed in the reaction on mixing the sulphuric acid with the watery solution of dichromate, it is necessary to use heat-resisting vessels. The best so far employed are those made of pyrex glass. Use ordinary tap water and the commercial dichromate and strong sulphuric acid. Chemically pure ingredients are not demanded.

Dissolve the dichromate in the water by the aid of heat. Use for this an agate dish. Now place the pyrex dish in the sink on some asbestos or a piece of board. Pour the warm solution of dichromate into the pyrex dish, and then add the sulphuric acid, stirring the liquid with a glass rod. The reaction is so great that the liquid will boil violently. An abundance of chromic acid crystals will form as the sulphuric acid is added. Let the pyrex dish remain in the sink until the cleaning mixture is cool and then pour it into a glass-stoppered bottle for storage.

If the dichromate is well pulverized it can be put directly into the pyrex dish with the requisite amount of water, and the sulphuric acid added as directed.

This is an excellent cleaning mixture and is practically odorless. It is exceedingly corrosive and must be kept in glass vessels. It may be used more than once, but when the color changes markedly from that seen in the fresh mixture it should be thrown away. An indefinite sojourn of the slides and covers in the cleaner does not seem to injure them.

MOUNTING, AND PERMANENT PREPARATION OF MICROSCOPIC OBJECTS

§ 498. **Mounting a microscopic object** is so arranging it upon some suitable support (glass slide) and in some suitable mounting medium that it may be satisfactorily studied with the microscope.

The cover-glass on a permanent preparation should always be considerably larger than the object; and where several objects are put under one cover-glass, as with serial sections, it is false economy to crowd them too closely together.

§ 499. **Temporary mounting; normal fluids.** — In a great many cases objects do not need to be preserved; they are then mounted in any way to enable one best to study them, and after the study the cover-glass is removed, and the slide cleaned for future use. In the study of living objects, of course only temporary preparations are possible. With amœbæ, white blood corpuscles, and many other objects, both animal and vegetable, the living phenomena can best be studied by mounting them in the natural medium. That is, for amœbæ, in the water in which they are found; for the white blood corpuscles, a drop of blood is used and, as the blood soon coagulates, they are in the serum. Sometimes it is not easy or convenient to get the natural medium; then some liquid that has been found to serve in place of the natural medium is used. For many things, water with a little common salt (water 1000 cc., common salt 7.5 grams) is employed. This is the so-called isotonic or normal salt or saline solution. For the ciliated cells from frogs and other amphibia, nothing has been found so good as human spittle. Whatever is used, the object is put on the middle of the slide and a drop of the mounting medium added, and then the cover-glass. The cover is best put on with fine forceps, as shown in fig. 190. After the cover is in place, if

the preparation is to be studied for some time, it is better to avoid currents and evaporation by painting a ring of castor oil around the cover in such a way that part of the ring will be on the slide and part on the cover (fig. 204).

It cannot be too strongly emphasized that if one is to study living or fresh tissues they must be mounted in a liquid which will not injure them. The liquid in which they are naturally found is of course the most nearly normal of any, and should be always used when possible. Water seems a very bland and harmless liquid, but it has a very decidedly injurious effect on living tissues which are normally bathed by

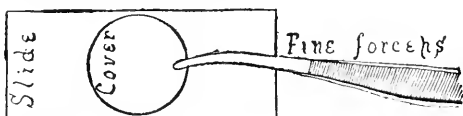

FIG. 100. FINE FORCEPS FOR HANDLING COVER-GLASSES AND OTHER DELICATE OBJECTS.

the fluids of the body, for they always contain salts and colloid material. Distilled water is more deleterious than tap water because it contains no

salts. It would be deleterious to water organisms, because all natural waters contain a greater or less quantity of organic and inorganic substances in solution. In examining water organisms use the water in which they are found. If the water supply of a city or town has a filtration plant the water is likely to be unsuitable for raising water forms like salamander embryos, and the embryos of the frogs and toads, besides many other water forms. One must take the trouble to get the water from the natural breeding places if the embryos are to be successfully raised in a laboratory. (See also § 520-521, 584.)

§ 500. **Permanent mounting.** — There are three great methods of making permanent microscopic preparations. Special methods of procedure are necessary to mount objects successfully in each of these ways. The best mounting medium and the best method of mounting in a given case can only be determined by experiment. In most cases some previous observer has already made the necessary experiments and furnished the desired information.

The three methods are the following:

- (1) Dry or in air (§ 501-504).
- (2) In some medium miscible with water, as glycerin or glycerin jelly (§ 505-509).

- (3) In some resinous medium like Canada balsam, damar, etc (§ 510-513).

§ 501. **Mounting dry or in air.** — The object should be thoroughly dry. If any moisture remains it is liable to cloud the cover-glass, and the specimen may deteriorate. As the specimen must be sealed, it is necessary to prepare a cell slightly deeper than the object is thick. This is to support the cover-glass, and also to prevent the running in by capillarity of the sealing mixture.

Order of procedure in mounting objects dry or in air.

1. A cell of some kind is prepared. It should be slightly deeper than the object is thick (§ 503).
2. The object is thoroughly dried (desiccated) either in dry air or by the aid of gentle heat.
3. If practicable the object is mounted on the cover-glass; if not it is placed in the bottom of the cell.
4. The slide is warmed till the cement forming the cell wall is somewhat sticky, or a very thin coat of fresh cement is added; the cover is warmed and put on the cell and pressed down all around till a shining ring indicates its adherence.
5. The cover-glass is sealed.
6. The slide is labeled.
7. The preparation is catalogued and safely stored.

§ 502. **Example of mounting dry, or in air.** — Prepare a shallow cell and dry it (§ 503). Select a clean cover-glass slightly larger than the cell. Pour upon the cover a drop of 10% solution of salicylic acid in 95% alcohol. Let it dry spontaneously. Warm the slide till the cement ring or cell is somewhat sticky; then warm the cover gently and put it on the cell, crystals down. Press on the cover all around the edge, seal, label, and catalogue.

A preparation of mammalian red blood corpuscles may be satisfactorily made by spreading a very thin layer of fresh blood on a cover with the end of a slide. After it is dry, warm gently to remove the last traces of moisture and mount blood side down, precisely as for the crystals. One can get the blood as directed for the Micro-spectroscopic work (§ 413).

§ 503. **Preparation of mounting cells.** — (A) *Thin cells.* These are most conveniently made of some of the cements used in microscopy. Shellac is one of the best and most generally applicable. To prepare a shellac cell place the slide on a turn-table (fig. 191) and center it, that is, get the center of the slide over the center of the turn-table. Select a guide ring on the turn-table which is a little smaller than the cover-glass to be used, take the brush from the shellac, being sure that there is not enough cement adhering to it to drop. Whirl

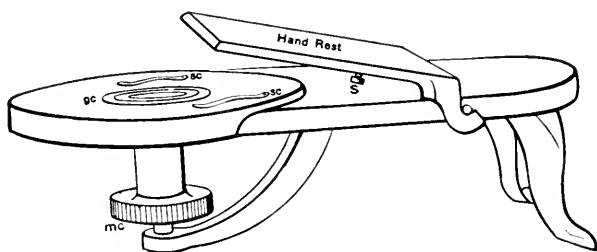

FIG. 191. TURN-TABLE FOR MAKING CELLS AND FOR SEALING COVER-GLASSES.

Hand Rest The metal plate supporting the hand that holds the brush. It can be raised or lowered by means of the screw underneath (*s*).

sc Spring clips for holding the slide in place.

gc Guide circles to aid in centering the slide or the mounted object.

mc Milled circular disc by which the turn-table is whirled when the ring of cement is being painted around the cover-glass or the mounting cell.

the turn-table and hold the brush lightly on the slide just over the guide ring selected. An even ring of cement should result. If it is uneven, the cement is too thick or too thin, or too much was on the brush. After a ring is thus prepared remove the slide and allow the cement to dry spontaneously, or heat the slide in some way. Before the slide is used for mounting, the cement should be so dry when it is cold that it does not dent when the finger nail is applied to it.

A cell of considerable depth may be made with the shellac by adding successive layers as the previous one dries.

(B) *Deep cells* are sometimes made by building up cement cells, but more frequently, paper, wax, glass, hard rubber, or some metal is used for the main part of the cell. Paper rings, block tin or lead

rings are easily cut out with gun punches. These rings are fastened to the slide by using some cement like the shellac.

§ 504. **Sealing the cover-glass for dry objects mounted in cells.** — When an object is mounted in a cell, the slide is warmed until the cement is slightly sticky or a very thin coat of fresh cement is put on. The cover-glass is warmed slightly also, both to make it stick to the cell more easily, and to expel any remaining moisture from the object. When the cover is put on, it is pressed down all around over the cell until a shining ring appears, showing that there is an intimate contact. In doing this use the convex part of the fine forceps or some other blunt, smooth object; it is also necessary to avoid pressing on the cover except immediately over the wall of the cell for fear of breaking the cover. When the cover is in contact with the wall of cement all around, the slide should be placed on the turn-table and carefully arranged so that the cover-glass and cell wall will be concentric with the guide rings of the turn-table. Then the turn-table is whirled and a ring of fresh cement is painted, half on the cover and half on the cell wall (fig. 204). If the cover-glass is not in contact with the cell wall at any point and the cell is shallow, there will be great danger of the fresh cement running into the cell and injuring or spoiling the preparation. When the cover-glass is properly sealed, the preparation is put in a safe place for the drying of the cement. It is advisable to add a fresh coat of cement occasionally.

§ 505. **Mounting objects in media miscible with water.** — Many objects are so greatly modified by drying that they must be mounted in some medium other than air. In some cases water with something in solution is used. Glycerin of various strengths and glycerin jelly are also much employed. All these media keep the object moist and therefore in a condition resembling the natural one. The object is usually and properly treated with gradually increasing strengths of glycerin or fixed by some fixing agent before being permanently mounted in strong glycerin or either of the other media.

In all of these different methods, unless glycerin of increasing strengths has been used to prepare the tissue, the fixing agent is washed away with water before the object is finally and permanently mounted in either of the media.

For glycerin jelly no cell is necessary unless the object has a considerable thickness.

§ 506. Order of procedure in mounting objects in glycerin —

1. A cell must be prepared on the slide if the object is of considerable thickness (§ 503).
2. A suitably prepared object is placed on the center of a clean slide, and if no cell is required a centering card is used to facilitate the centering (fig. 192).

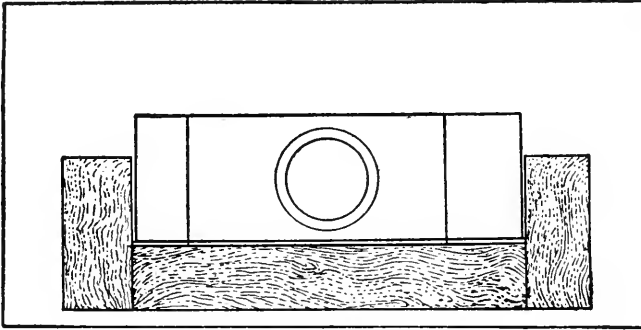

FIG. 192. GUIDE CARD TO AID IN MOUNTING OBJECTS NEATLY.

3. A drop of pure glycerin is poured upon the object, or if a cell is used, enough to fill the cell and a little more.

4. In putting on the cover-glass it is grasped with fine forceps and the underside breathed on to slightly moisten it so that the glycerin will adhere; then one edge of the cover is put on the cell or slide and the cover gradually lowered upon the object. The cover is then gently pressed down. If a cell is used, a fresh coat of cement is added before mounting.

5. The cover-glass is sealed.
6. The slide is labeled.
7. The preparation is catalogued and safely stored.

§ 507. Order of procedure in mounting objects in glycerin jelly.

1. Unless the object is quite thick no cell is necessary with glycerin jelly.

2. A slide is gently warmed and placed on the centering card (fig. 192) and a drop of warmed glycerin jelly is put on its center. The suitably prepared object is then arranged in the center of the slide.

3. A drop of the warm glycerin jelly is then put on the object, or if a cell is used it is filled with the medium.

4. The cover-glass is grasped with fine forceps, the lower side breathed on and then gradually lowered upon the object and gently pressed down.

5. After mounting, the preparation is left flat in some cool place till the glycerin jelly sets; then the superfluous amount is scraped and wiped away and the cover-glass sealed with shellac (§ 508).

6. The slide is labeled.

7. The preparation is catalogued and safely stored.

§ 508. **Sealing the cover-glass when no cell is used.**—(A) *For glycerin-mounted specimens.* The superfluous glycerin is wiped away as carefully as possible with a moist cloth; then four minute drops of cement are placed at the edge of the cover (fig. 193) and allowed to harden for half an hour or more. These will anchor the cover-glass; then the preparation may be put on the turn-table and ringed with cement while whirling the turn-table.

(B) *For objects in glycerin jelly, Farrants' solution or a resinous medium.* The mounting medium is first allowed to harden; then the superfluous medium is scraped away as much as possible with a knife, and then removed with a cloth moistened with water for the glycerin jelly and Farrants' solution or with alcohol, chloroform or turpentine, etc., if a resinous medium is used. Then the slide is put on a turn-table and a ring of the shellac cement added.

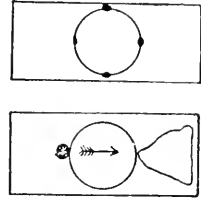

FIG. 193. ANCHORING THE COVER-GLASS AND IRRIGATION.

A This is to show the method of anchoring a cover-glass by means of four drops of cement so that it may be sealed on the turn-table without danger of displacing the cover.

B Method of irrigation. A drop of the irrigating liquid is put on one side of the cover-glass and a piece of absorbent paper on the other. As shown by the arrow the liquid is drawn through. As it spreads more or less on both sides all degrees of the reaction produced by the liquid can be found in the same preparation.

(C) *Balsam preparations* may be sealed with shellac as soon as they are prepared, but it is better to allow them to dry for a few days. One should never use a cement for sealing preparations in balsam or other resinous media if the solvent of the cement is also a solvent of the balsam, etc. Otherwise the cement will soften the balsam and finally run in and mix with it, and partly or wholly ruin the preparation. Shellac is an excellent cement for sealing balsam preparations, as it never runs in. Balsam preparations are rarely sealed.

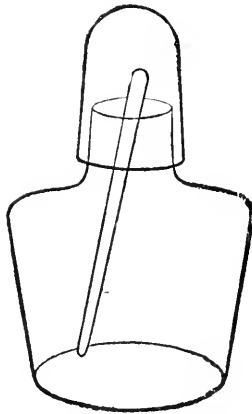

FIG. 194. SMALL SPIRIT LAMP USED AS A CONTAINER FOR GLYCERIN, BALSAM, ETC.

§ 509. **Example of mounting in glycerin jelly.** — For this select some stained and isolated muscular fibers or other suitably prepared objects (§ 514-519). Arrange them on the middle of a slide, using the centering card, and mount in glycerin jelly as directed in § 507. Air bubbles are not easily removed from glycerin jelly preparations, so care should be taken to avoid them.

§ 510. **Mounting objects in resinous media.** — While the media miscible with water offer many advantages for mounting animal and vegetable tissues, the preparations so made are liable to deteriorate. In many cases, also, they do not produce sufficient transparency to enable one to use high enough powers for the demonstration of minute details.

By using sufficient care almost any tissue may be mounted in a resinous medium and retain all its details of structure.

For the successful mounting of an object in a resinous medium it must in some way be deprived of all water and all liquids not miscible with the resinous mounting medium. There are two methods of bringing this about: (A) By drying or desiccation (§ 511), and (B) by successive displacements (§ 513).

§ 511. **Order of procedure in mounting objects in resinous media by desiccation:**

1. The object suitable for the purpose (fly's wings, etc.) is thoroughly dried in dry air or by gentle heat.

2. The object is arranged as desired in the center of a clean slide on the centering card (fig. 192).

3. A drop of the mounting medium is put directly upon the object or spread on a cover-glass.

4. The cover-glass is put on the specimen with fine forceps (fig. 190), but in no case does one breathe on the cover as when media miscible with water are used.

5. The cover-glass is pressed down gently.

6. The slide is labeled.

7. The preparation is catalogued and safely stored (§ 526).

§ 512. **Example of mounting in balsam by desiccation.** — Find a fresh fly, or, if in winter, procure a dead one from a window sill or a spider's web. Remove the fly's wings, being especially careful to keep them the dorsal side up. With a camel's hair brush remove any dirt that may be clinging to them. Place a clean slide on the centering card, then with fine forceps put the two wings within one of the guide rings. Leave one dorsal side up, turn the other ventral side up. Spread some Canada balsam on the face of the cover-glass and with the fine forceps place the cover upon the wings (fig. 190). Probably some air-bubbles will appear in the preparation, but if the slide is put in a warm place these will soon disappear. Label, catalogue, etc.

§ 513. **Mounting in resinous media by a series of displacements.** — For examples of this see the procedure in the paraffin and in the collodion methods, Ch. XI. The first step in the series is *dehydration*; that is, the water is displaced by some liquid which is miscible both with the water and the next liquid to be used. Strong alcohol (95% or stronger) is usually employed for this. Plenty of it must be used to displace the last trace of water. The tissue may be soaked in a dish of the alcohol, or alcohol from a pipette may be poured upon it.

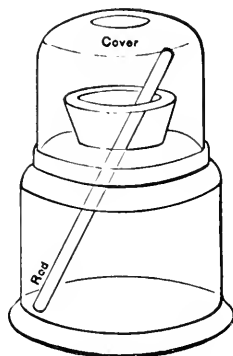

FIG. 195. CONTAINER FOR CANADA BALSAM, GLYCERIN JELLY, ETC.

Cover The glass cover to keep out dust and prevent evaporation.

Rod The glass rod for transferring the contents of the container to the slide.

Dehydration usually occurs in the thin objects to be mounted in balsam in 5 to 15 minutes. If a dish of alcohol is used it must not be used too many times, as it loses in strength.

The second step is clearing. That is, some liquid which is miscible with the alcohol and also with the resinous medium is used. This liquid is highly refractive in most cases, and consequently this step is called *clearing* and the liquid a *clearer*. The clearer displaces the alcohol, and renders the object more or less translucent. In case the water was not all removed, a cloudiness will appear in parts or over the whole of the preparation. In this case the preparation must be returned to alcohol to complete the dehydration.

One can tell when a specimen is properly cleared by holding it over some dark object. If it is cleared it can be seen only with difficulty, as but little light is reflected from it. If it is held toward the window, however, it will appear translucent.

The third and final step is the displacement of the clearer by the resinous mounting medium.

The specimen is drained of clearer and allowed to stand for a short time till there appears the first sign of dullness from evaporation of the clearer from the surface. Then a drop of the resinous medium is put on the object, and finally a cover-glass is placed over it, or a drop of the mounting medium is spread on the cover and it is then put on the object. For abundant examples see the next chapter.

ISOLATION OF HISTOLOGIC ELEMENTS

§ 514. *Isolation, general.* — For a correct conception of the forms of the cells and fibers of the various organs of the body, one must see these elements isolated and thus be able to inspect them from all sides. It frequently occurs also that the isolation is not quite complete, and one can see in the clearest manner the relations of the cells or fibers to one another.

The chemical agents or solutions for isolating are, in general, the same as those used for hardening and fixing. But the solutions are only about one-tenth as strong as for fixing, and the action is very much shorter, that is, from one or two hours to as many days. In the weak solution the cell cement or connective tissue is softened so

that the cells and fibers may be separated from one another, and at the same time the cells are preserved. In fixing and hardening, on the other hand, the cell cement, like the other parts of the tissue, is made firmer. In preparing the isolating solutions it is better to

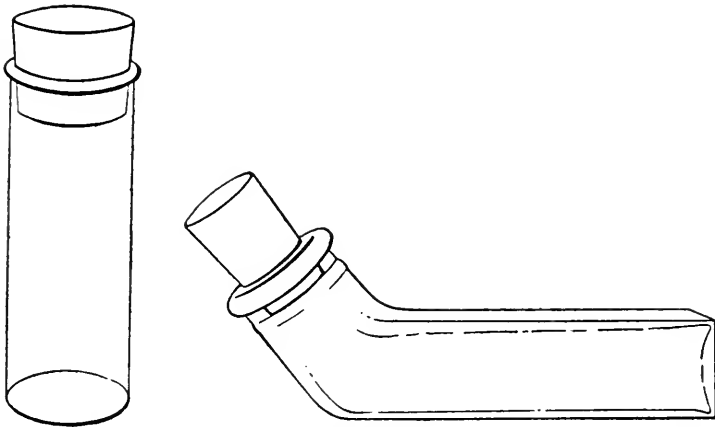

FIG. 196, 197. SHELLVIAL AND COMSTOCK, BENT-NECK SPECIMEN BOTTLE.

FIG. 196. Shellvial with turned lip. One can have almost any size and length desired. Those of 22×65 mm. and 30×90 mm. have been found most useful. The larger ones are excellent for staining single slides or pairs.

FIG. 197. The Comstock, bent-neck specimen bottle is very useful for keeping small animals straight.

dilute the fixing agents with normal salt solution than merely with water (§ 584).

§ 515. **Example of isolation.** — Place a piece of the trachea of a very recently killed animal, or the roof of a frog's mouth, in formaldehyde dissociator in a shell vial or glass box. After half an hour, up to two or three days, excellent preparations of ciliated cells may be obtained by scraping the trachea or roof of the mouth and mounting the scrapings on a slide. If one proceeds after one hour, probably most of the cells will cling together, and in the various clumps will appear cells on end showing the cilia or the bases of the cells, and other clumps will show the cells in profile. By tapping the cover

gently with a needle holder or other light object the cells will separate from one another, and many fully isolated cells will be seen.

§ 516. **Isolation by means of formaldehyde.** — Formaldehyde in normal salt solution is one of the very best dissociating agents for brain tissue and all the forms of epithelium. It is prepared as follows: 2 cc. of formal (that is, a 40% solution of formaldehyde) are mixed with 1000 cc. of normal salt solution. This acts quickly and preserves delicate structures like the cilia of ordinary epithelia and also of the endymal cells of the brain. It is satisfactory for isolating the nerve cells of the brain. For the epithelium of the trachea, intestines, etc., the action is sufficient in half an hour; good preparations may also be obtained any time within two days or more. The action on nerve tissue of the brain and myel or spinal cord is about as rapid.

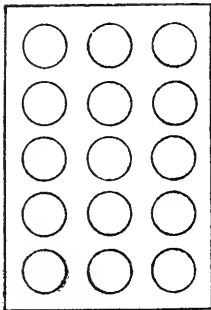

FIG. 198. BLOCK WITH HOLES FOR SHELL-VIALS.

The blocks are about 33 mm. thick and the holes are bored clear through, then a board about 5 mm. thick is nailed on the bottom.

§ 517. **Staining the cells.** — Almost any stain may be used for the formalin dissociated cells. For example, one may use eosin. This may be drawn under the cover of the already mounted preparation (fig. 193), or a new preparation may be made and the scrapings mixed with a drop of eosin before putting on the cover-glass. It is an advantage to study unstained preparations, otherwise one might obtain the erroneous opinion that the structure cannot be seen unless

it is stained. The stain makes the structural features somewhat plainer; it also accentuates some features and does not affect others so markedly. Congo red is excellent for most isolated cells.

§ 518. **Permanent preparations of isolated cells.** — If one desires to make a permanent preparation of isolated cells it may be done by placing a drop of glycerin at the edge of the cover and allowing it to diffuse under the cover, or the diffusion may be hurried by using a piece of blotting paper, as shown in fig. 193. One may also make a new preparation by mixing thoroughly some of the isolated material with congo-glycerin. After a few minutes the cover-glass may be

put on and sealed (§ 508). If one adds congo-glycerin to a considerable amount of the isolated material it may be kept and used at any time.

§ 519. **Isolation of muscular fibers.** — For this the formal dissociator may be used (§ 516), but the nitric acid method is more successful (§ 560). The fresh muscle is placed in this in a glass vessel. At the ordinary temperature of a sitting room (20 degrees centigrade)

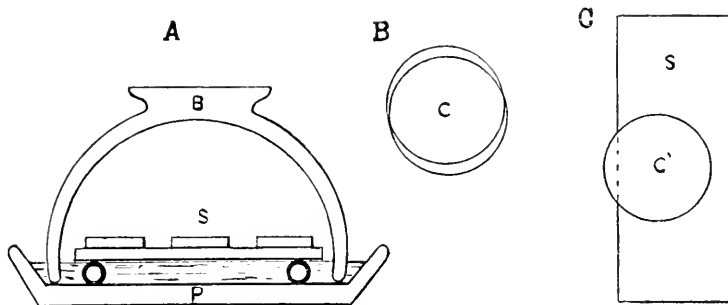

FIG. 199. MOIST CHAMBER AND MOIST PREPARATIONS.

A Bowl (B) inverted over a plate (P) containing water and a glass shelf supported on glass rods. The slides (S) are supported on the glass shelf. This makes a very efficient and cheap moist chamber.

B Cover-glasses (C) made slightly eccentric and containing between them the object to be kept moist. By using cover-glasses the specimen can be examined from both sides, and as part usually remains with each cover-glass, two permanent preparations can be made.

C Slide (S) with a cover-glass (C) extending slightly over one edge so that it can be lifted up without danger of sliding it along and thus disarranging the specimen.

the connective tissue will be so far gelatinized in from one to three days that it is easy to separate the fascicles and fibers either with needles or by shaking in a test tube or shell vial with water. It takes longer for some muscles to dissociate than others, even at the same temperature, so one must try occasionally to see if the action is sufficient. When it is, the acid is poured off and the muscles washed gently with water to remove the acid. If one is ready to make the preparations at once they may be isolated and mounted in water. If it is desired to keep the specimen indefinitely or several days, the water should be poured off and 2% formaldehyde added. The speci-

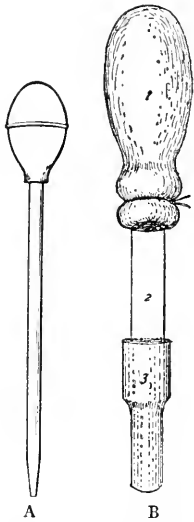

FIG. 200. PIPETTES FOR LIQUIDS AND FOR SPECIMENS.

A Pipette for liquids. This is about one-third size.

B Pipette for handling ova and other delicate specimens.

1 The rubber bulb tied to the glass part. It is about natural size.

2 Glass rod. The upper end is fluted so that the rubber bulb will not come off, and the lower end is carefully smoothed by heating. To prevent small ova and other objects getting into the bulb, some fine gauze may be tied over the upper end.

3 Soft rubber tube over the lower end. This is not absolutely necessary, but the soft rubber is less liable to injure delicate objects than the hard glass.

mens may be mounted in glycerin, glycerin jelly, or balsam. Glycerin jelly is the most satisfactory, however.

COLLECTION AND STUDY OF MICROSCOPIC ANIMALS AND PLANTS

§ 520. Collection of material. — There are many microscopic forms in nature that need no other preparation than mounting on a glass slide. If low powers are used a cover-glass may be omitted, but if high powers are to be used a cover-glass must be put over the object to protect the objective as well as the object, and to make the optical corrections of the objective perfect (§ 460).

The easiest places to find things most interesting and beautiful is in the water of pools and along the shores of streams where the water is quiet. Go to some pond or stream and along the shore where it is shallow; take some of the vegetation and the mud, put in a pail or dish, and take to the home or laboratory. Put the water and vegetation in a plate or other shallow vessel and put it in about the same light that it had in nature. In a few hours, when the mud has settled the conditions will be nearly as in nature, and by the use of fine forceps or one of the pipettes (fig. 190, 200), gather some of the water with scrapings from some of the vegetation, or some of the water and mud. Put it on a slide, cover and examine. There may be much to see or very little. One must persevere and finally there will come a kind of instinctive knowledge where to find things. It is also a good plan to use the tripod or other magnifier and examine the dish. Often much can be seen in that way, and one will get a hint where to col-

lect the bits to put on the slide for examination. Do not use distilled water for these organisms, but water from the source of supply. (For food see § 521).

§ 521. **Infusoria and bacteria; Infusions.** — One of the best ways to get a large variety of living forms, animal and vegetable, is to make such a gathering as described above and to put it into a small fruit jar or other wide open vessel, and to put with it some of the stems of the grass along the stream. If in a moderately warm place for a day or more this collection will be found swarming with living things. Soon, however, the

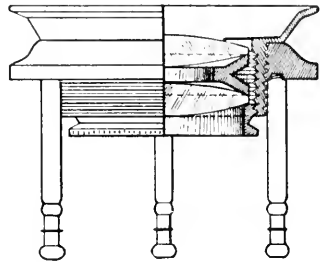

FIG. 201. TRIPOD MAGNIFIER.

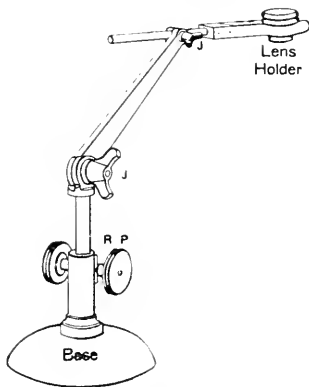

FIG. 202. MAGNIFIER SUPPORTED BY A FOCUSING, JOINTED HOLDER.

Base The heavy iron base to keep the apparatus steady.

R P Rack and pinion for focusing the magnifier.

J J Joints to make it possible to put the lens in any desired position.

numbers will lessen and finally there will be very few left. These living things need food. One of the good foods for them is the soup made from boiling up some of the grass and hay found near the natural habitat. Any good hay may be used, however. When the soup is cool add some of it to the vessel containing the organisms, or what is better take another dish, add the soup and a fair amount of the liquid from the first gathering. Usually this new supply will be as rich in life as was the original gathering. (See under Neutral Red (§ 582) for experiment in staining live forms.)

§ 522. **Diatoms.** — These are plants with silicious shells, and are found in natural waters both salt and fresh. If one goes to a pond or stream in May or June or July especially, the diatoms are very abundant. They may be found at any time, but in the spring most abundantly, as with most living things. The brownish

or rusty looking substance on plants, rocks, etc., practically always contain diatoms, and sometimes is made up mostly of them. It is most interesting to study the diatoms alive and watch them glide around in the water. The shells of the diatoms have been favorite objects of study for a long time. They are often beautifully marked. Being silicious, they resist acids, and the living substance in and around them can be destroyed without hurting the shells. This may be done by placing the material containing a large number of diatoms in a test tube and when the diatoms have settled pour off a part of the liquid or draw it out with the pipette (fig. 200 A), and add an equal amount of nitric acid. Boil for a few minutes, let the diatoms settle, pour off or draw off most of the liquid, and add more nitric acid and boil again. Finally, add water and gradually wash the diatom shells by drawing off the water and adding fresh. The shells should be clean and almost colorless and show their markings well. One can take a sample and see if the cleaning is sufficient. (For full and elaborate directions see Boyer's *Diatomaceæ of Philadelphia and Vicinity*, p. 122-123).

§ 523. **Arranging minute objects.** — Minute objects like diatoms or the scales of insects may be arranged in geometrical figures or in some fanciful way, either for ornament or more satisfactory study. To do this the cover-glass is placed over the guide. This guide for geometrical figures may be a net-micrometer or a series of concentric circles. In order that the objects may remain in place, however, they must be fastened to the cover-glass. As an adhesive substance, mucilage or liquid gelatin (§ 578), thinned with an equal volume of 50% acetic acid, answers well. A very thin coating of this is spread on the cover with a needle, or in some other way, and allowed to dry. The objects are then placed on the gelatinized side of the cover and carefully got into position with a mechanical finger, made by fastening a cat's whisker in a needle holder. For most of these objects a simple microscope with stand (fig. 201-202) will be found of great advantage. After the objects are arranged, one breathes very gently on the cover-glass to soften the mucilage or gelatin. It is then allowed to dry, and if a suitable amount of gelatin has been used and it has been properly moistened, the objects will be found firmly anchored. In

mounting one may use Canada balsam or mount dry on a cell (§ 504, 511). See Newcomer, *Amer. Micr. Soc.'s Proc.*, 1886, p. 128; see also E. H. Griffith and H. L. Smith, *Amer. Jour. of Micros.*, iv, 102, v, 87; *Amer. Monthly Micr. Jour.*, i, 66, 107, 113; Cunningham, *The Microscope*, viii, 1888, p. 237.

LABELING, CATALOGUING AND STORING MICROSCOPIC PREPARATIONS

§ 524. Every person possessing a microscopic preparation is interested in its proper management; but it is especially to the teacher and investigator that the labeling, cataloguing, and storing of microscopic preparations are of importance. "To the investigator, his specimens are the most precious of his possessions, for they contain the facts which he tries to interpret, and they remain the same while his knowledge, and hence his power of interpretation, increase. They thus form the basis of further or more correct knowledge; but in order to be safe guides for the student, teacher, or investigator, it seems to the writer that every preparation should possess two things: viz. a label and a catalogue or history. This catalogue should indicate all that is known of a specimen at the time of its preparation, and all of the processes by which it is treated. It is only by the possession of such a complete knowledge of the entire history of a preparation that one is able to judge with certainty of the comparative excellence of methods, and thus to discard or improve those which are defective. The teacher, as well as the investigator, should have this information in an accessible form, so that not only he, but his students, can obtain at any time all necessary information concerning the preparations which serve him as illustrations and them as examples."

§ 525. **Labeling ordinary microscopic preparations.** — The label should possess at least the following information.

The number of the preparation, its name and date and the thickness of the sections and of the cover-glass.

§ 526. **Cataloguing preparations.** — It is believed from personal experience, and from the experience of others, that each preparation (each slide or each series) should be accompanied by a catalogue containing at least the information suggested in the following formula. This formula is very flexible, so that the order may be changed, and

numbers not applicable in a given case may be omitted. With many objects, especially embryos and small animals, the time of fixing and hardening may be months and even years earlier than the time of imbedding. So, too, an object may be sectioned a long time after it was imbedded, and finally the sections may not be mounted at the time they are cut. It would be well in such cases to give the date of fixing under 2, and under 5, 6 and 8 the dates at which the operations, were performed if they differ from the original date and from one

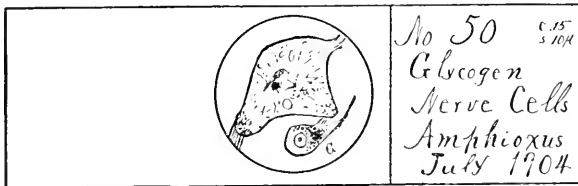

FIG. 203. LABEL FOR A MICROSCOPIC PREPARATION.

The specimen is the myel (spinal cord) of an *Amphioxus* showing the dorsal and ventral nerve roots, and some nerve cells near the middle.

G A nerve-cell with glycogen.

In the label *c. 15* means that the cover-glass is 0.15 mm. in thickness; and *s 10 μ* means that the section is ten microns thick. The date at the bottom shows when the specimen was made.

another. In brief, the more that is known about a preparation the greater its value.

§ 527. General formula for cataloguing microscopic preparations:

1. The general name and source. Thickness of cover-glass and of section.
2. The number of the preparation and the date of obtaining and fixing the specimen; the name of the preparator.
3. The special name of the preparation and the common and scientific name of the object from which it is derived. Purpose of the preparation.
4. The age and condition of the object from which the preparation is derived. Condition of rest or activity; fasting or full fed at the time of death.
5. The chemical treatment, — the method of fixing, hardening, dissociating, etc., and the time required.

6. The mechanical treatment, — imbedded, sectioned, dissected with needles, etc. Date at which done.

7. The staining agent or agents and the time required for staining.

8. Dehydrating and clearing agent, mounting medium, cement used for sealing.

9. The objectives and other accessories (micro-spectroscope, polarizer, etc.), for studying the preparation.

10. Remarks, including references to original papers, or to good figures and descriptions in books.

§ 528. A catalogue card written according to this formula:

1. Muscular Fibers of Cat; Cover 0.15 mm.; Fibers 20μ to 40μ thick.

2. No. 475. (Drr. IX) Oct. 1, 1891. S. H. G., Preparator.

3. Tendinous and intra-muscular terminations of striated muscular fibers from the *Sartorius* of the cat (*Felis domestica*).

4. Cat eight months old, healthy and well nourished. Fasting and quiet for 12 hours.

5. Muscle pinned on cork with vaselined pins and placed in 20 per cent nitric acid immediately after death by chloroform. Left 36 hours in the acid; temperature 20° C. In alum water ($\frac{1}{2}$ sat. aq. sol.) 1 day.

6. Fibers separated on the slide with needles, Oct. 3.

7. Stained 5 minutes with Delafield's hematoxylin.

8. Dehydrated with 95% alcohol 5 minutes, cleared 5 minutes with carbol-turpentine, mounted in xylene balsam; sealed with shellac.

9. Use a 16 mm. for the general appearance of the fibers, then a 2 or 3 mm. objective for the details of structure. Try the micro-polariscope (§ 421).

10. The nuclei or muscle corpuscles are very large and numerous; many of the intra-muscular ends are branched. See S. P. Gage, Proc. Amer. Micr. Soc., 1890, p. 132; Ref. Hand-book Med. Sci., Vol. V, p. 59.

§ 529. General remarks on catalogues and labels. — It is especially desirable that labels and catalogues shall be written with some imperishable ink. Some form of water-proof carbon ink is the most available and satisfactory. The water-proof India ink, of Higgins or

Weber, answers well. For ordinary writing it should be diluted with one-third its volume of water and a few drops of strong ammonia added.

If one has a writing diamond it is a good plan to write a label with it on one end of the slide. It is best to have the paper label also, as it can be more easily read.

The author has found stiff cards, $12\frac{1}{2} \times 7\frac{1}{2}$ cm., like those used for cataloguing books in public libraries, the most desirable form of catalogue. A specimen that is for any cause discarded has its catalogue card destroyed or stored apart from the regular catalogue. New cards may then be added in alphabetical order as the preparations are made. In fact a catalogue on cards has all the flexibility and advantage of the slip system of notes.

Some workers prefer a book catalogue. Very excellent book catalogues have been devised by Alling and by Ward (Jour. Roy. Micr. Soc., 1887, pp. 173, 348; Amer. Monthly Micr. Jour., 1890, p. 91; Amer. Micr. Soc. Proc., 1887, p. 233).

The fourth division has been added, as there is coming to be a strong belief, practically amounting to a certainty, that there is a different structural appearance in many if not all of the tissue elements, depending upon the age of the animal, upon its condition of rest or fatigue; and for the cells of the digestive organs, whether the animal is fasting or full fed. Indeed as *physiological histology* is recognized as the only true histology, there will be an effort to determine exact data concerning the animal from which the tissues are derived. (See Minot, Proc. Amer. Assoc. Adv. Science, 1890, pp. 271-289; Hodge, on nerve cells in rest and fatigue, Jour. Morph., vol. VII (1892), pp. 95-168; Jour. Physiol., vol. XVII, pp. 129-134; Gage, The Processes of Life revealed by the Microscope; a Plea for Physiological Histology, Proc. Amer. Micr. Soc., vol. XVII (1895), pp. 3-29; Science, vol. II, Aug. 23, 1895, pp. 209-218. Smithsonian Institution, Report for 1896, pp. 381-396.

CABINET FOR MICROSCOPIC PREPARATIONS

§ 530. While it is desirable that microscopic preparations should be properly labeled and catalogued, it is equally important that they

should be protected from injury. During the last few years several forms of cabinets or slide holders have been devised. Some are very cheap and convenient where one has but a few slides. For a laboratory or for a private collection where the slides are numerous the following characters seem to the writer essential:

(1) The cabinet should allow the slides to lie flat, and exclude dust and light.

(2) Each slide or pair of slides should be in a separate compartment. At each end of the compartment should be a groove or bevel, so that upon depressing either end of the slide the other may be easily grasped (fig. 204). It is also desirable to have the floor of the compartment grooved so that the slide rests only on two edges, thus preventing soiling the slide opposite the object.

(3) Each compartment or each space sufficient to contain one slide of the standard size should be numbered, preferably at each end. If the compartments are made of sufficient width to receive two slides, then the double slides so frequently used in mounting serial sections may be put into the cabinet in any place desired.

(4) The drawers of the cabinet should be entirely independent, so that any drawer may be partly or wholly removed without disturbing any of the others.

(5) On the front of each drawer should be the number of the drawer

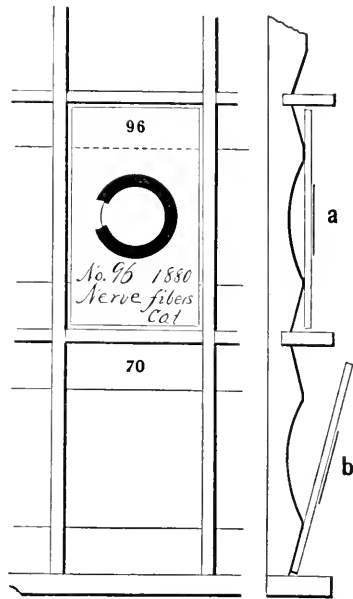

FIG. 204. FACE AND EDGE VIEW OF A CABINET DRAWER FOR MICROSCOPIC SLIDES.

96, 70 The number of the compartment.

a b In the compartment a, the slide is resting in place to show that the container touches the slide only in two places.

In b, the slide is depressed into the groove at one end of the compartment. It is then easy to grasp the slide.

in Roman numerals, and the number of the first and last compartment in the drawer in Arabic numerals (fig. 205).

§ 531. **Trays for slides and ribbons of sections.** — Early in 1897 the writer devised the simple tray shown in fig. 206. It was designed especially for the ribbons of sections in preparing embryologic series

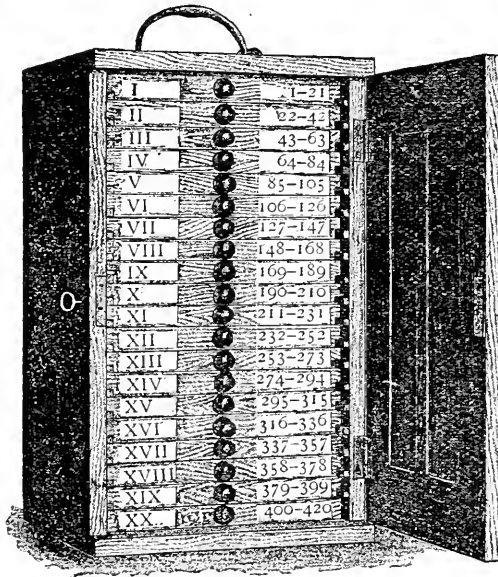

FIG. 205. CABINET FOR MICROSCOPE SLIDES.

This cabinet contains 20 drawers like that shown in fig. 204, and as indicated at the right there are 420 compartments for slides.

lockers (fig. 208) and naturally came to be used for storage instead of the expensive slide cabinets. For this purpose five could be put in a single compartment of the locker or thirty-five in an entire locker. As each tray holds fifty slides 25×75 mm.; thirty-five 38×75 mm., and twenty-five slides 50×75 mm., the saving of space was very great.

§ 532. **Slide trays with tongue, groove, and compartments.** — In the first trays the edges were square and sharp. These were rounded

and for material for class work. As will be seen by the figure the two slides are alike and the tray is very shallow. It was soon found that the wood forming the bottom of the tray was too rough for ribbons of sections and smooth white paper was put in the tray before the ribbons were laid upon it.

These trays were soon used for the mounted preparations as well as for the ribbons of sections. They were made of a proper size to fit the laboratory

in later trays, but there still remained a defect, for if one wished to pile up five to twenty trays on the table, they would not stay in an even stack. To remedy this defect the long way of the frame was tongued on one side and grooved on the other, as shown in fig. 207. This is a great improvement, as one can make even stacks of 25 or 50 trays, and they will stay in position. Furthermore it renders the groups of five trays stored in the locker compartments much easier

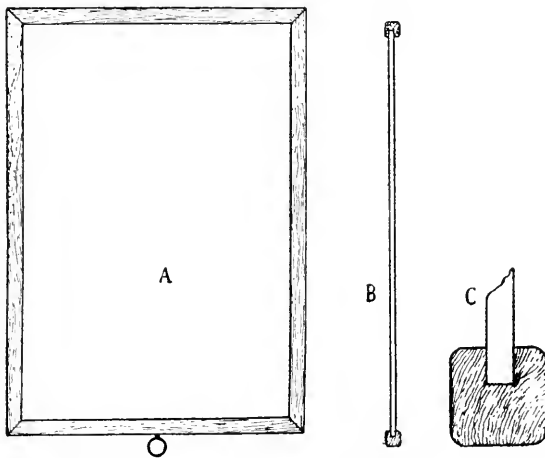

FIG. 206. SIMPLEST FORM OF SLIDE TRAY.

A Face view of the slide tray. The screw eye at the lower end is convenient for pulling out a single tray.

B Sectional view of the tray showing the thin board of which it is made and the wooden frame.

C Sectional view showing how the frame is fastened to the board.

to manage, as one can remove any of the five trays without getting the others disarranged, as so often occurred with the old form, lacking tongue and groove.

A defect of the trays for storage is the ease with which the slides get disarranged unless the tray is entirely full. To overcome this defect Mrs. Gage divided one face of the tray into columns (fig. 207) by means of stout cord held in place by using melted paraffin as a cement. Later Dr. Greenman of the Wistar Institute divided one

face of the tray into columns by wooden strips. This is the best way. With the tray face in columns the slides in a single column may become disarranged, but there is no mixing of the slides of different

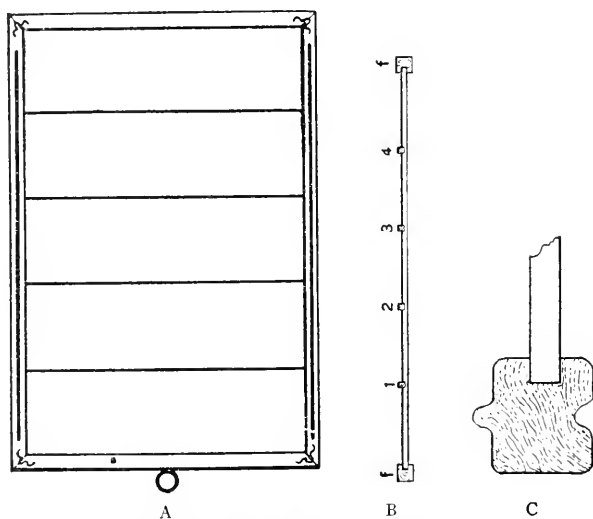

FIG. 207. SLIDE TRAY WITH COMPARTMENTS, AND WITH TONGUE AND GROOVE IN THE SIDE PIECES OF THE FRAME.

A Face view of the newest form of slide tray showing the five compartments and the tongue on the side pieces.

B Longitudinal section of the tray showing the frame (*f*) and the partitions, 1, 2, 3, 4.

C Sectional view showing the side piece with tongue and groove and the method of connecting the frame to the board. In these new forms the board is not wood, but pulp, called beaver-board. The partitions are of wood, and are nailed in place, not glued.

columns. One side of the tray remains smooth and can be used for ribbons of sections or for any other purpose like the original tray (fig. 206).

§ 532a. — In Ithaca, these trays are made and furnished by the H. J. Bool Furniture Co. The cost per 100 of the original form is \$17.50 (§ 531); for the form with tongue and groove, it is \$22.50; and for the form with tongue and groove and one side divided into rows (§ 532), the cost is \$30 per hundred.

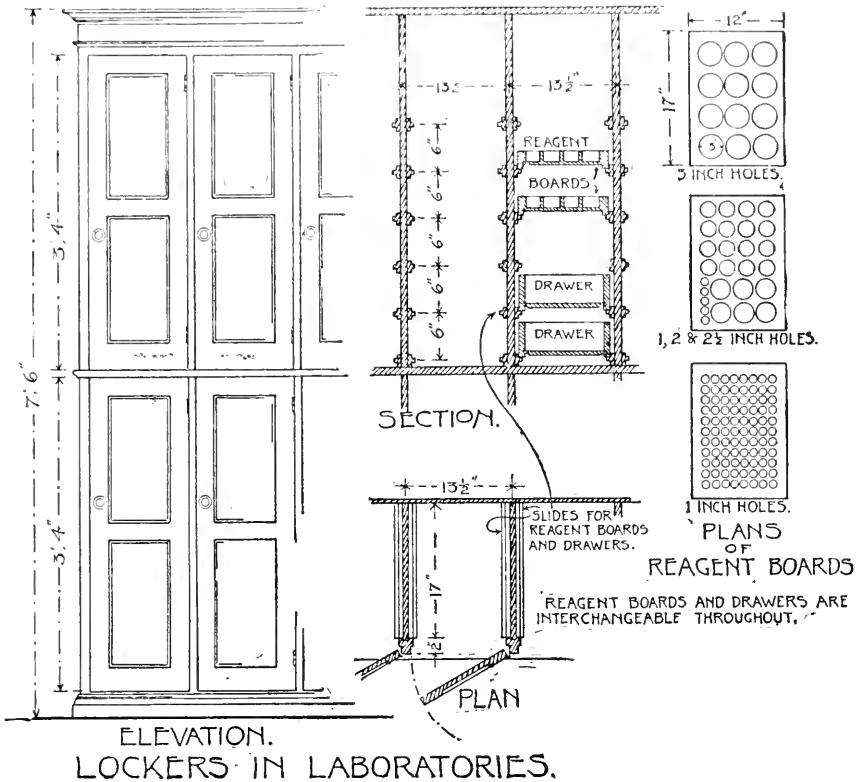

FIG. 208. LABORATORY LOCKERS REAGENT BOARDS AND DRAWERS DESIGNED IN 1895.

(From the Journal of Applied Microscopy, 1898, p. 127).

The lockers designed in 1899 for Stimson Hall are in banks of 12 or 9, with three vertical tiers, not two as shown in this figure. Everything is of standard size and hence completely interchangeable.

Measured over all, the locker banks are 329 cm. high, and 139.5 cm. wide for the large banks and 105 wide for the smaller banks. Each individual locker, inside measure, is 32 cm. wide, 70.5 cm. high, and 48 cm. deep. It is divided by 7 runs into 8 compartments. As indicated in the sectional view, the entire space may be left free in the locker or partly filled or it may be wholly filled.

Each bank of lockers is lettered, and then the individual lockers numbered from 1-12 or 1-9, the numbering is in the order of words in a book, i.e., from left to right. Of course vertical numbering is equally feasible. With this form of numbering each bank is practically independent and can be changed in position without confusion.

REAGENTS FOR MICROSCOPIC WORK

§ 533. — For much of the work done with a microscope the reagents needed are few and inexpensive, but for a large laboratory with the diversity of investigations carried on the reagents are numerous, and some of them expensive. Below are given some of the principal ones with the method of their preparation.

§ 534. **General on preparation of reagents.** — In preparing reagents both weights and measures are used. As a rule the amounts given are those which experience has shown to give good results. Variations in the proportions of the mixtures are sometimes advantageous, and in almost every case a slight change in the proportions makes no difference. Most laboratory reagents are like food, good even under quite diverse proportions and methods of preparation. With a few, however, it is necessary to have definite strengths.

By a *saturated solution* is meant one in which the liquid has dissolved all that it can of the substance added. This varies with the temperature. It is well to have an excess of the substance present; then the liquid will be saturated at all temperatures usually found in the laboratory.

§ 535. **Solutions less than 10 per cent.** — In making solutions where dry substance is added to a liquid, if the percentage is not over 10%, the custom is to take 100 cc. of the liquid and add to it the number of grams indicated by the per cent. That is, for a 5% solution one would take 100 cc. of the liquid and 5 grams of the dry substance. This does not make a strictly 5% solution. For that one should take 95 cc. of liquid and 5 grams of the dry substance; or, if the percentage must be exact, then one should weigh out 95 grams of the liquid and add 5 grams of the dry substance.

§ 536. **Solutions of 10 per cent and more.** — When the percentage is 10% or over it is better to weigh out the number of grams representing the percentage and add to it the right amount of liquid in cubic centimeters. For example, if one were to make a 35% aqueous solution of caustic potash in water then one would add 35 grams of caustic potash to 65 cc. of water. If one wished to make a 10% alcoholic solution of caustic potash he would add 10 grams of caustic

potash to 90 cc. of alcohol. But here is a case where the alcohol being of less specific gravity than water the mixture would not weigh 100 grams; and to make the mixture weigh 100 grams, giving therefore an exact percentage, one should take 90 grams of alcohol and add to it 10 grams of caustic potash. In practice in making solutions of colodion or parlodion one usually mixes ether and 95% or absolute alcohol in equal volumes and then for a 10% solution 10 grams of the dry soluble cotton or parlodion are added to 90 cc. of the ether-alcohol mixture. But ether is much lighter than water and the alcohol somewhat lighter, so that the percentage in this case would be more than 10%, because the 90 cc. of alcohol and ether would weigh considerably less than 90 grams.

§ 537. **Mixtures of liquids to obtain a desired percentage.** — It frequently happens that it is desired to obtain a lower percentage or strength of a liquid than the one in stock. This is very readily done according to the general formula: Divide the percentage of the strong solution by the percentage of the desired solution and the quotient will show how many times too strong the stock solution is.

To get the desired strength, use 1 volume of the strong stock solution, and add to it enough of the diluting liquid to make a volume corresponding to the amount indicated by the quotient obtained by dividing the percentage of the stock solution by that of the desired solution. For example, if it is desired to obtain a 5% solution of formaldehyde from a stock solution of 40% strength, the stock solution being 8 times too strong, to get the 5% solution 1 volume of the strong solution must be used and 7 volumes of the diluting liquid (water). The solution so obtained will be $\frac{1}{8}$ of the original strength, or 5%.

If a 2% solution were desired then 1 volume of the strong solution would be taken and 19 volumes of water, etc.

§ 538. **Mixtures of alcohol.** — For alcohol if one desires a 50% solution it is usually near enough correct to add equal parts of 95% alcohol and water, but this does not actually give a 50% solution. To find the real proportions according to the general formula: $95\% \div 50\% = 1.9$, i.e., for every 1 cc. of 95% alcohol should be added 0.9 cc. of water or for each 100 cc. of 95% alcohol, 99 cc. of water. This

even will not give an exact mixture of alcohol, for a mixture of alcohol and water diminishes somewhat in volume. To get true percentages an alcoholometer for testing the specific gravity is used.

A simple method of getting approximately correct mixtures of alcohol is the following: Pour the strong alcohol into a graduate glass (fig. 209AB) until the volume is the same as the desired percentage;

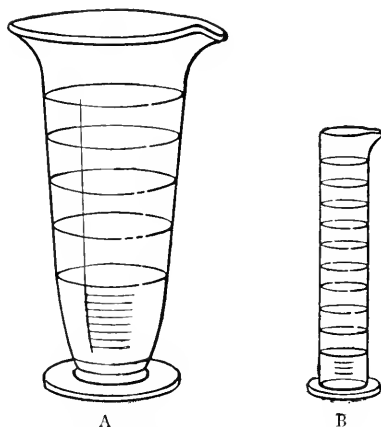

FIG. 200. GLASS GRADUATES FOR MEASURING LIQUIDS.

A Graduate with sloping sides for large quantities.

B Graduate with straight sides for smaller quantities and more accurate determination.

then add water until the volume is the same as the original percentage of the alcohol. Example: To get 50% from 95% alcohol put 50 cc. of 95% into a graduate and fill the graduate to 95 cc. with water, and the resulting mixture will be 50% alcohol, and so with all other strengths. Here the shrinkage is eliminated from consideration, because the water and alcohol are not measured separately and then mixed, but one is added to the other until a given volume is attained.

PREPARATION OF REAGENTS

§ 539. Albumen fixative (Mayer's). — This consists of

equal parts of well-beaten white of egg and glycerin. To each 50 cc. of this 1 gram of salicylate of soda is added to prevent putrefactive changes. This must be carefully filtered. For method of use see Ch. XI.

§ 540. Alcohol (ethyl), C_2H_5OH . — Ethyl or grain alcohol is mostly used for histologic purposes. (A) Absolute alcohol (i.e., alcohol of 99%) is recommended for many purposes, but if plenty of 95% alcohol is used it answers every purpose in histology, in a dry climate or in a warm, dry room. When it is damp, dehydration is greatly facilitated by the use of absolute alcohol.

(B) 82% alcohol made by mixing 5 parts of 95% alcohol with 1 part of water.

(C) 67% alcohol made by mixing 2 parts of 95% alcohol with 1 part of water. See also § 537-538.

§ 541. **Alcohol (methyl), CH_3OH .** — Methyl alcohol or wood alcohol is much cheaper than ethyl or grain alcohol on account of the revenue tax on ethyl alcohol. It answers well for many microscopic



FIG. 210. GLASS-STOPPERED BOTTLES FOR THE MORE USUAL GRADES OF ALCOHOL USED IN MICROSCOPY.

purposes. It has been refined so carefully in recent years that the disagreeable odor is not very noticeable.

§ 542. **Denatured alcohol.** — This is ethyl or grain alcohol rendered undrinkable by the addition of wood alcohol and benzine (grain alcohol, 89½%; methyl alcohol 10%, and benzine ½%). In some cases the denaturing substances are somewhat different, but all render the alcohol unusable for drinking. It is then free from internal revenue tax.

In Great Britain "*Methylated Spirits*" consists of grain alcohol with 10% methyl alcohol. This is used very largely in microscopic work. In America the addition of the benzine renders denatured alcohol also unfit for histological purposes if it is to be diluted. The addition of water makes it milky. If methyl alcohol alone or combined with pyridin or some other substance wholly soluble in water were used as the denaturing substance, denatured alcohol could be used in microscopic work for all the grades. That denatured as indicated above can be used only in full strength or very slightly diluted.

For educational and other public institutions the U. S. government grants the privilege of using ethyl alcohol without paying the revenue tax, but for private institutions and for individuals it would be a great relief if the denatured alcohol could be mixed in all proportions with water without the formation of precipitates.

§ 543. **Balsam, Canada balsam, balsam of fir.** — This is one of the oldest and most satisfactory of the resinous media used for mounting microscopic preparations.

The natural balsam is most often used; it has the advantage of being able to take up a small amount of water so that if sections are not quite dehydrated they will clear up after a time.

§ 544. **Xylene balsam.** — This is Canada balsam diluted or thinned with xylene. It is recommended by many to evaporate the natural balsam to dryness and then to dissolve it in xylene. For some purposes, e.g. for mounting glycogen preparations, this is advantageous; but it is unnecessary for most purposes. Xylene balsam requires a very complete desiccation or dehydration of objects to be mounted in it, for the xylene is immiscible with water.

The hydrocarbon, xylene (C_8H_{10}) is called xylol in German. In English, members of the hydrocarbon series have the termination "ene," while members of the alcohol series terminate in "ol."

§ 545. **Filtering balsam.** — Balsam is now furnished already filtered through filter paper. If xylene balsam is used it may be made thin and filtered without heat. For filtering balsam and all resinous and gummy materials, the writer has found a paper funnel the most satisfactory. It can be used once and then thrown away. Such a funnel may be easily made by rolling a sheet of thick writing paper in the form of a cone and cementing the paper where it overlaps, or winding a string several times around the lower part. Such a funnel is best used in one of the rings for holding funnels, so common in chemical laboratories. The filtering is most successfully done in a very warm place, like an incubator or an incubator room.

§ 546. **Neutral balsam.** — All the samples of balsam tested by the author have been found slightly acid. This is an advantage for carmine and acid fuchsin stain or any other acid stain. Also for preparations injected with carmine or Berlin blue. In these cases

the color would fade or diffuse if the medium were not slightly acid. For hematoxylin and many other stains the acid is detrimental. For example, the slight amount of acid in the balsam causes the delicate stain in the finest fibers of Weigert preparations to fade. To neutralize the balsam add some pure sodium carbonate, set the balsam in a warm place, and shake it occasionally. After a month or so the soda will settle and the clear supernatant balsam will be found very slightly alkaline. Use this whenever an acid medium would fade the stain in the specimen.

§ 547. **Acid balsam.** — As stated above all balsam is naturally somewhat acid, but for various stains it is desirable to increase the acidity. For example, specimens stained with picro-fuchsin, or injected with carmine or Berlin blue are more satisfactory and last longer with full brilliancy if the balsam is made more acid than it naturally is. For this use 10 to 20 drops of glacial acetic or formic acid to 100 cc. of balsam.

§ 548. **Borax carmine for *in toto* staining.** — Borax 4 grams; carmine 3 grams; water 100 cc. Shake frequently for several days and then filter and add 100 cc. of 67% alcohol. After 3 to 4 days it may be necessary to filter again. Good for *in toto* staining after almost any fixer. Put the object to be stained from alcohol into a vial with plenty of stain. After a day or two change the stain. Stain 4 to 5 days. Remove to 67% alcohol, adding 4 drops of HCl to each 100 cc. of alcohol. After one day remove to 82% alcohol. Change the alcohol till no more color comes away, then proceed to section. Remember that objects stained *in toto* may be mounted directly in balsam from deparaffining xylene.

§ 549. **Carmine for mucus (mucicarmin).** — One can buy the dry powder or preferably prepare the stain. To prepare it take 1 gram of Carmine No. 40 and $\frac{1}{2}$ gram of pure dry ammonium chlorid. If the latter is slightly moist, dry it in an evaporating dish in a sand bath. Mix the ammonium chlorid and the carmine and add 2 cc. of water. Mix well and heat over a sand bath, constantly mixing with a glass rod. Continue the heating until the carmine colored mass becomes very dark red. It will take 3 to 10 minutes for this. The heat should not be too great.

Dissolve the dark red mixture in 100 cc. of 50% alcohol. For use, dilute five or tenfold with tap water. This stains best after mercuric fixers. One must not collodionize sections to be stained with this, as the carmine stains the collodion very deeply. Stain the sections first with hematoxylin as usual; then stain 1 to 5 hours or longer with the dilute mucicarmin. The mucus in goblet cells, in the mucous part of the salivary glands, etc., will be red. Nuclei will be stained with hematoxylin. Mount in balsam (§ 513).

§ 550. **Cedar-wood oil.** — For penetrating tissues and preparing them for infiltration with paraffin, thick oil is recommended by Lee. For tissues fixed with osmic acid for fat the thick oil is necessary, but for most histologic and embryologic work, that known as Cedar-wood Oil (Florida) is excellent, also that known as Cedar-wood Oil (true Lebanon). These forms are far less expensive than the thick oil. The tissues should be thoroughly dehydrated before putting them into cedar-wood oil, and they should remain until they are translucent.

The thickened cedar-wood oil used for homogeneous immersion should be obtained of the manufacturers of microscopes; they naturally would supply the kind suitable for the purpose.

§ 551. **Chloroform (CHCl₃).** — This is used as an anæsthetic and for clearing and imbedding where fats fixed with osmic acid are to be preserved in the tissues. It is also used for hardening collodion, in collodion imbedding. It is an excellent solvent of cedar-wood oil and is used for cleaning homogeneous immersion fluid (cedar-oil) from objectives, condensers and microscopic preparations.

§ 552. **Carbol-xylene clearer.** — Vasale recommends as a clearer, xylene 75 cc., carbolic acid (melted crystals), 25 cc.

§ 552a. — Carbol-xylene and eosin. In order to counterstain with eosin during the clearing process, the carbol-xylene is charged with eosin as follows: A saturated aqueous solution of eosin is prepared, and to it is added with constant stirring, hydrochloric acid until there is a good precipitate. Filter through filter paper. Wash the precipitate with distilled water until the water goes through pink. This indicates that the acid is washed out. Dry the washed precipitate. This is soluble in the carbol-xylene and enough should be added to make that pink. More or less can be used depending on the depth of the eosin stain desired. That can be regulated also by the time the sections are left in the eosined clearer. (Freeborn, Jour. Ap. Microscopy, Vol. III, p. 1058).

§ 553. **Carbol-turpentine clearer.** — A satisfactory and generally applicable clearer is carbol turpentine, made by mixing carbolic acid

crystals (*Acidum carbolicum. A. phenicum crystallizatum*) 40 cc. with rectified oil of turpentine (*Oleum terebinthinae rectificatum*) 60 cc. If the carbolic acid does not dissolve in the turpentine, increase the turpentine, thus: carbolic acid 30 cc., turpentine 70 cc.

This clearer is not so good as the preceding for mounting objects which have been stained with osmic acid, as the hydrogen dioxide (H_2O_2) present fades the blackened osmic acid.

§ 554. **Clarifier, castor-xylene clarifier.** — This is composed of castor oil 1 part and xylene 3 parts. (Trans. Amer. Micr. Soc., 1895, p. 361.) For the use of this clarifier, see under the collodion method, (§ 635).

§ 555. **Collodion.** — This is a solution of soluble cotton or other form of pyroxylin in equal parts of sulphuric ether in 95% or absolute alcohol. In using soluble cotton for infiltrating and imbedding tissues several different strengths are used, commencing with weak and proceeding to strong mixtures. The last in which the tissue is imbedded is as thick a solution as can be made. All collodion solutions should be kept well corked, for the ether and alcohol are very volatile.

§ 555a. — The substance used in preparing collodion goes by various names, soluble cotton or collodion cotton is perhaps best. This is cellulose nitrate, and consists of a mixture of cellulose tetranitrate $C_{12}H_{16}(NO_2)_4O_6$ and cellulose pentanitrate, $C_{12}H_{15}(NO_2)_5O_5$. Besides the names soluble and collodion cotton, it is called gun cotton and pyroxylin. Pyroxylin is the more general term and includes several of the cellulose nitrates. Celloidin is a patent preparation of pyroxylin, more expensive than soluble cotton.

An American product known as "parlodion" has recently (1915) appeared to take the place of the celloidin not now obtainable. It is non-explosive, and said to be a very pure, concentrated form of collodion especially adapted to the needs of histology and embryology. (Advertising pages, Anatomical Record, Dec., 1915.)

Soluble cotton should be kept in the dark to avoid decomposition. After it is in solution this decomposition is not so liable to occur. The decomposition of the dry cotton gives rise to nitrous acid, and hence it is best to keep it in a box loosely covered, so that the nitrous acid may escape.

Cellulose nitrate is explosive under concussion and when heated to 150° centigrade. In the air, the loose soluble cotton burns without explosion. It is said not to injure the hand if held upon it during ignition and that it does not fire gunpowder if burned upon it. So far as known to the writer, no accident has ever occurred from the use of soluble cotton for microscopic purposes. I wish to express my thanks to Professor W. R. Orndorff, organic chemist in Cornell University, for the above information. (Proc. Amer. Micr. Soc., vol. XVII (1895), pp. 361-370.)

§ 556. **Collodion for cementing sections to the slide.** — This is a $\frac{3}{4}\%$ solution made by adding $\frac{3}{4}$ gram of soluble cotton to 50 cc. of

95% or absolute alcohol and 50 cc. of sulphuric ether. This may be used before deparaffining or preferably afterward. See § 622.

§ 557. **Congo red.** — Water 100 cc., Congo red $\frac{1}{2}$ gram. This is a good counter stain for hematoxylin.

§ 558. **Congo-glycerin.** — For mixing with and staining isolation preparations (§ 517) and for a mounting medium this is an excellent combination. It is particularly good for nerve cells.

§ 559. **Decalcifier.** — For removing the salts of lime from bone, etc., one must first fix and harden the tissue by some approved method. 67% alcohol 100 cc.; strong nitric acid 3 cc. Change two or three times. It takes from 3 to 10 days, depending on the object. One can tell when the decalcification is complete by inserting a needle. If there is no gritty feeling the work is done. Then wash a few minutes in water and transfer to 67% alcohol. Then after 24 hours use 82% alcohol. It is usually better to section by the collodion method. Tissue is liable to deteriorate after being decalcified, so section it soon.

§ 560. **Dissociating Liquids.** — These liquids are for preserving the tissue elements or cells and for dissolving or softening the intercellular substance so that the cells may be readily separated from their neighbors. The separation is accomplished by (a) teasing with needles; (b) shaking in a liquid in a test tube; (c) scraping with a scalpel and crushing with the flat of the blade; (d) by tapping sharply on the cover-glass after the object is mounted. One may find it desirable to use (d) with all the methods.

(1) Formaldehyde dissociator. — Strong formalin (40% formaldehyde gas in water) 2 cc. Normal salt solution 1000 cc. One can begin work within $\frac{1}{2}$ hour and good results may be obtained after 2 to 3 days immersion. Excellent for epithelia and for nerve cells.

(2) Müller's fluid dissociator. — Müller's fluid 1 cc. Normal salt solution 9 cc. It usually requires from 1 to 5 days for epithelia to dissociate in this. The action is more rapid in a warm place.

(3) Nitric acid dissociator. — Nitric acid 20 cc. Water 80 cc. This is used especially for muscular tissue. It takes from 1 to 3 days, depending on the temperature. The nitric acid gelatinizes the connective tissue. Wash out the acid with water for a few minutes. Preserve in 2% formaldehyde.

§ 561. **Elastic stain.** — For staining elastic substance the resorcin-basic-fuchsin-iron-chlorid of Weigert is available. The stain is prepared as follows.

Basic fuchsin 2 grams. Resorcin 4 grams. Water 200 cc. Boil for several minutes (5 to 10). Add to the boiling mixture 25 cc. of a 30% aqueous solution of chlorid of iron (FeCl_6). Boil for 3 to 10 minutes; then add a saturated solution of the iron chlorid until the color is all precipitated. Try the liquid occasionally by letting a few drops run down the side of the glass beaker used for the boiling. If the color is precipitated it appears as fine granules and the liquid is almost uncolored or slightly yellow.

Allow the liquid to cool. If there is plenty of time let it stand over night. Then either pour off the supernatant liquid or if the precipitate has not settled filter through filter paper. Then either scrape off the precipitate from the filter paper or cut off the lower end of the filter containing the precipitate and put it in the beaker. Add 200 cc. of 95% alcohol and heat over a water bath till the alcohol boils. Continue the boiling 5 minutes or more and stir up the filter paper so that all the precipitate may be dissolved. After boiling 5 minutes or more filter the hot alcoholic solution into a warmed bottle. After this alcoholic solution is cool add 5 cc. of strong hydrochloric acid.

Stain sections in this solution 1 hour, sometimes less. Wash off the stain with 95% alcohol.

This works well on sections by the paraffin or the collodion method and for tissues hardened in any manner.

§ 562. **Eosin.** — This is used mostly as a contrast stain with hematoxylin, which is almost a purely nuclear stain. It serves to stain the cell-body, ground substance, etc., which would be too transparent and invisible with hematoxylin alone. If eosin is used alone it gives a decided color to the tissue and thus aids in its study. Eosin is used in alcoholic and in aqueous solutions. A very satisfactory stain is made as follows: 50 cc. of water and 50 cc. of 95% alcohol are mixed and $\frac{1}{10}$ of a gram of dry eosin added. $\frac{1}{2}$ % aqueous eosin is also good.

§ 563. **Eosin in 95 per cent alcohol.** — For staining embryos and tissues so that the tissue in the ribbons of sections may be easily seen

a saturated solution of alcoholic eosin is made. This is also used for staining with methylene blue (§ 564).

§ 564. **Eosin-Methylene blue.** — Alcohol-soluble eosin, 3 grams; 95% alcohol, 500 cc. Methylene blue, pure, 2 grams; 95% alcohol 50 cc.; distilled water 450 cc. 1% aqueous solution of caustic potash, 5 cc.

For staining with this, material hardened in a mercuric mixture is best. Stain sections or smears 1 to 5 minutes in the eosin. Rinse well in water. Stain 1 to 5 minutes in the methylene blue solution. Rinse well in tap water. Dehydrate quickly with absolute alcohol. Clear in pure xylene and mount in neutral balsam (§ 546).

§ 565. **Ether, ether-alcohol.** — Sulphuric ether ($C_2H_5)_2O$ is meant when ether is mentioned in this book. Wherever ether-alcohol is mentioned it means a mixture of equal volumes of sulphuric ether and 95% or absolute alcohol, unless otherwise stated.

§ 566. **Farrant's solution.** — Take 25 grams of clean, dry gum arabic, 25 cc. of a saturated aqueous solution of arsenious acid, 25 cc. of glycerin. The gum arabic is soaked for several days in the arsenic water, then the glycerin is added and carefully mixed with the dissolved or softened gum arabic.

This medium retains air bubbles with great tenacity. It is much easier to avoid than to get rid of them in mounting.

§ 567. **Flemming's Fluid.** — Water 19 cc.; 1% osmic acid 10 cc.; 10% chromic acid 3 cc.; glacial acetic acid 2 cc. This osmic fixer is good for very small pieces — 1 to 5 millimeter pieces, thickness not over 2 to 3 mm. Wash out with water 10 to 24 hours. Then 67% alcohol. Also 82% and 95%.

§ 568. **Formaldehyde ($HCHO$ or OCH_2).** — This is found in the market under the name of "formalin," etc., and consists of a 40% solution of formaldehyde gas in water.

For fixing tissues and embryos a 5% solution is good (formalin 1 cc., water 7 cc., § 537). A common fixer is 10 cc. formalin, 90 cc. water. This is frequently called 10% formalin; it is, however, only 4% formaldehyde.

Tissues may stay in this indefinitely. Small pieces are fixed within an hour. Before hardening in alcohol and imbedding, wash

out the formalin in running water half an hour, then harden a day or more in 67% and 82% alcohol.

For preserving nitric acid dissociated muscle a 2% formaldehyde solution is good. (Formalin 1 cc., water 19 cc. § 537.) See also § 516 (1) for the formaldehyde dissociator.

§ 569. **Glycerin.** — (A) One should have pure glycerin for a mounting medium. It needs no preparation, unless it contains dust, when it should be filtered through filter paper or absorbent cotton.

To prepare objects for final mounting, glycerin 50 cc., water 50 cc., forms a good mixture. For many purposes the final mounting in glycerin is made in an acid medium, viz., glycerin 99 cc., glacial acetic or formic acid, 1 cc.

By extreme care in mounting and by occasionally adding a fresh coat to the sealing of the cover-glass, glycerin preparations last a long time. They are liable to be disappointing, however. In mounting in glycerin care should be taken to avoid air-bubbles, as they are difficult to get rid of. A specimen need not be discarded, however, unless the air-bubbles are large and numerous. See also Congo glycerin § 517-518.

§ 570. **Glycerin jelly for microscopic specimens.** — Soak 25 grams of the best dry gelatin in cold water in a pyrex or agateware dish. Allow the water to remain until the gelatin is softened. It usually takes about half an hour. When softened, as may be readily determined by taking a little in the fingers, pour off the superfluous water and drain well to get rid of all the water that has not been imbibed by the gelatin. Warm the softened gelatin over a water bath and it will melt in the water it has absorbed. Add about 5 cc. of egg albumen, white of egg; stir it well and then heat the gelatin in the water bath for about half an hour. Do not heat above 75° or 80° C., for if the gelatin is heated too hot it will be transformed into meta-gelatin and will not set when cold. Heat coagulates the albumen and it forms a kind of flocculent precipitate which seems to gather all fine particles of dust, etc., leaving the gelatin perfectly clear. After the gelatin is clarified, filter through a hot flannel filter and mix with an equal volume of glycerin and 5 grams of chloral hydrate and shake thor-

oughly. If it is allowed to remain in a warm place (i.e., in a place where the gelatin remains melted) the air-bubbles will rise and disappear.

In case the glycerin jelly remains fluid or semi-fluid at the ordinary temperature (18° – 20° C.), the gelatin has either been transformed into meta-gelatin by too high a temperature or it contains too much water. The amount of water may be lessened by heating at a moderate temperature over a water bath in an open vessel. This is an excellent mounting medium. Air-bubbles should be avoided in mounting as they do not disappear.

§ 571. **Glycerin jelly for anatomic preparations.** — Specimens prepared by the Kaiserling method or other satisfactory way may be permanently preserved in glycerin jelly prepared as follows: Best clear gelatin, 200 grams. Kaiserling's No. 4 solution, 3000 cc. (Potassium acetate, 100 grams; glycerin, 200 cc.; water, 1000 cc). Put the gelatin in the potassium-acetate-glycerin-water mixture in an agate pail and heat over a gas or other stove. Stir. When the temperature is about 55° centigrade add the whites of three eggs well beaten, and stir them in vigorously. Make markedly acid by acetic acid. Continue the heating until the mixture just boils, and then filter through filter paper into fruit jars. It is best to put over the filter paper two thicknesses of gauze. A piece of thymol in the top of each jar will prevent the growth of fungi, or one can add 5% chloral hydrate. Specimens are mounted in this jelly directly from the No. 4 Kaiserlings, or alcoholic specimens can be soaked in water an hour or more and then kept in some of the melted jelly until well soaked; then mount permanently in the glycerin jelly. At the time of mounting the gelatin is liquefied over a water bath, and for every 20 cc. of the gelatin used one drop of strong formalin is added. This is to prevent the liquification of the gelatin after the specimen is mounted. Let the gelatin cool gradually after the specimen is in place, then add some melted gelatin to make the vessel over full and slide a glass cover on it. This excludes all air. The cover may then be sealed with the clear gelatin or glue used for gluing wood, or the cement used in mending crockery. Finally, one can seal with rubber cement if desired. (See W. H. Watters, N.Y. Med. Record, Dec. 22, 1906.)

§ 572. **Chloral hematoxylin.** — Potash alum, 4 grams; distilled water 125 cc.; hematoxylin crystals $\frac{1}{10}$ gram. Boil 5 to 10 minutes in an agate or pyrex dish. After cooling, add 3 grams of chloral hydrate and put into a bottle. This will stain more rapidly after a week or two if the bottle is left uncorked. It takes from 1 to 5 minutes to stain sections, — sometimes a long time. Use after any method of fixation.

It may be prepared for work at once by the addition of a small amount of hydrogen dioxide (H_2O_2).

If the stain is too concentrated it may be diluted with freshly distilled water or with a mixture of water, alum and chloral. If the stain is not sufficiently concentrated, more hematoxylin may be added. (Proc. Amer. Micr. Soc., 1892, pp. 125-127.)

§ 573. **Iron hematoxylin.** — For this stain there are three solutions: (a) the mordant composed of a 2% aqueous solution of ferric alum (iron-ammonium-persulphate); (b) a 0.5% solution of hematoxylin (10% alcoholic hematoxylin 5 cc., distilled water 95 cc.); (c) the differentiating fluid is composed of the ferric alum diluted several times.

The stain can be used after any fixer, and the steps are as follows: (1) mordant with the ferric alum 1 to 24 hours; (2) rinse the specimen 10 to 30 minutes in water; (3) stain for 3 to 24 hours in the hematoxylin; (4) differentiate slowly, watching the effect under the microscope. For this dip the slide into the ferric alum in the differentiator for a few seconds and then rinse with tap water. When satisfactory wash in running water 15 to 60 minutes. The mordant and stain may be used several times.

§ 574. **Hematein.** — This is used instead of hematoxylin, as it is believed to give more satisfactory results. Prepare as follows: Put a 5% solution of potash alum in distilled water and boil or leave in a steam sterilizer an hour or two. While warm add 1 per cent of hematein dissolved in a small quantity of alcohol. After the fluid has cooled add 2 grams of chloral for each 100 cc. of solution. (Freeborn, Jour. Ap. Micr. 1900, p. 1056.)

§ 575. **Iodin stain for glycogen.** — Iodin $1\frac{1}{2}$ gram; iodid of potassium 3 grams; sodium chlorid $1\frac{1}{2}$ grams; water 300 cc. For very

soluble glycogen one can use 50% alcohol 300 cc. instead of water. The iodine stain is the most precise and differential for glycogen. Tissues or embryos for glycogen are fixed and hardened in 95% or absolute alcohol, and sectioned by the paraffin or by the collodion method. For permanent preparations the paraffin method is best

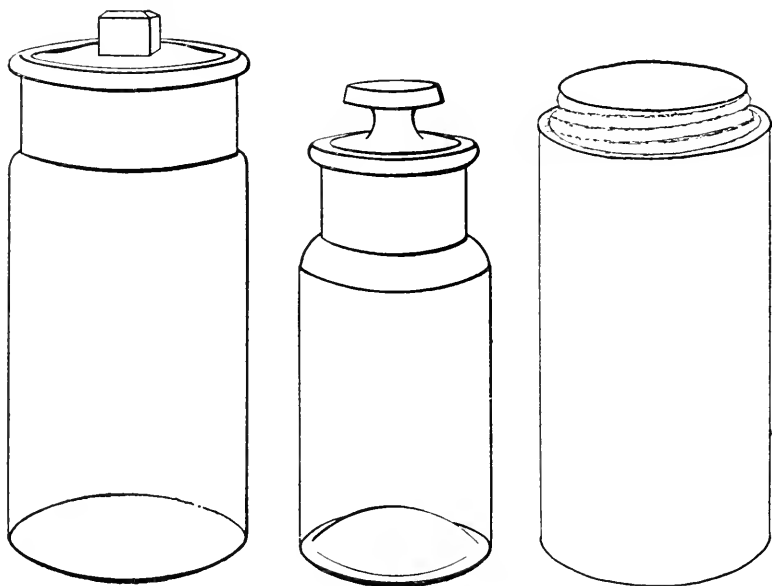

FIG. 211-213. BOTTLES FOR FIXING AND PRESERVING TISSUES.

Fig. 211. Wide mouth specimen bottle with glass stopper.

Fig. 212. Salt mouth bottle with glass stopper.

Fig. 213. Glass jar with screw top.

(§ 623). In spreading the sections use this iodine stain instead of water. Glycogen in the sections stains a mahogany red, and the stain remains for ten or more years in the spread paraffin sections. Spread sections may be stained or restained by immersing the slide in iodine stain.

Before mounting permanently, deparaffin with xylene, and mount in melted yellow vaseline. Press the cover down gently. Seal with shellac or balsam. (Gage, *Trans Amer. Micr. Soc.*, 1906, pp. 203-205.)

§ 576. **Iodin in alcohol.** — Iodin 10 grams; 95% alcohol 90 cc. This is the strong stock solution.

For removing the pin-like or granular mercuric crystals from sections of objects fixed in any fixer containing mercury, e.g. Zenker's fluid, etc., take 95% alcohol 500 cc. and the 10% iodine solution 5 cc. In some cases, where the amount of mercury in the tissue is great, one may use 10 or even 15 cc. of the strong stock solution. Rinse the slide well in pure 95% alcohol to remove the iodine after all the crystals have dissolved ($\frac{1}{2}$ an hour or more).

For embryos and tissues fixed in a mercuric fixer one can add several drops of the stock solution to the alcohol containing the tissue and then by changing the alcohol occasionally the mercury will be mostly removed before sectioning. It is readily removed from the sections as just described.

§ 577. **Lamp-black for ingestion by leucocytes.** — Lamp-black, 2 grams; sodium chlorid, 1 gram; gum acacia (gum Arabic), 1 gram; distilled water, 100 cc. Mix all thoroughly in a mortar. The gum arabic is to aid in getting an emulsion of the lamp-black. Filter through one thickness of gauze and one of lens paper. If for a mammal sterilize by boiling. If some of this mixture is injected into an animal, the leucocytes will ingest the carbon particles. Carmine may be used instead of lamp-black, but it is not as good because not so enduring as lamp-black.

§ 578. **Liquid gelatin.** — Gelatin or clear glue, 75 to 100 grams; glacial acetic acid 40 cc. and water 160 cc.; 95% alcohol 100 cc.; glycerin 15 to 30 cc. Crush the glue and put it into a bottle with the acid, set in a warm place, and shake occasionally. After three or more days add the other ingredients. This solution is excellent for fastening paper to glass, wood, or paper. The brush must be mounted in a quill or wooden handle. For labels, it is best to use linen paper of moderate thickness. This should be coated with liquid gelatin and allowed to dry. The labels may be cut of any desired size and attached by simply moistening them, as in using postage stamps.

Very excellent blank labels are now furnished by dealers in microscopic supplies, so that it is unnecessary to prepare them one's self,

except for special purposes. Those like that shown in fig. 203 may be had for about \$3 for 10,000.

§ 579. **Mercuric chlorid** (HgCl_2). — Mercuric chlorid $7\frac{1}{2}$ grams; sodium chlorid 1 gram; water 100 cc. The solution is facilitated by heating in an agate dish. Fix fresh tissue in this 2 to 24 hours. Then transfer to 67% alcohol a day or more and then to 82% alcohol. Tissues fixed in mercuric chlorid deteriorate; hence it is better to imbed them soon after they are fixed. Crystals of mercury are removed from the sections by the use of iodized alcohol (§576).

§ 580. **Methylene blue, alkaline.** — Methylene blue 2 grams; 95% or absolute alcohol 50 cc.; distilled water 450 cc.; 1% aqueous caustic potash 5 cc. This stain works best after a fixer containing mercuric chlorid, like Zenker's fluid (see § 563 for eosin in alcohol).

§ 581. **Müller's fluid.** — Potassium dichromate $2\frac{1}{2}$ grams; sodium sulphate, 1 gram; water 100 cc. This is one of the oldest fixers. It must act a long time, two weeks to 10 or 12 weeks. This longer time is for nervous tissue to be stained for the myelin. Lately this fixer has been combined with mercury (see Zenker's fluid § 592). Before putting the tissue into 67% alcohol it is washed out in running water for 24 hours.

Müller's fluid 10 cc.; normal salt solution 90 cc. forms an excellent dissociator for epithelia, etc. (§ 514).

§ 582. **Neutral red.** — This is used especially for staining living animals. It is used in very weak solutions: $\frac{1}{10}$ gram red; 1000 cc. of water. Put a few cubic centimeters of this solution into the vessel containing the live animal, or animals. Infusoria stain quickly, 10 to 20 minutes or less. Vertebrates may require a few days. Try it on infusoria by adding a drop of the red to several drops of the infusion containing the infusoria. Be sure that there are many animals present. Watch them under the microscope and the color will be seen appearing in the granules of the infusoria. Then one may cover and study with a high power (see § 521).

§ 583. **Nitric acid, HNO_3 .** — This is employed for dissociation (nitric acid dissociator: water 80 cc., nitric acid 20 cc.); as a fixer, especially for chick embryos in the early stages (water 90 cc.; nitric acid, 10 cc.), and as a delcacier (nitric acid 3cc.; 67% alcohol 100 cc.).

§ 584. **Normal liquids.** — A normal liquid or fluid is one which does not injure or change a fresh tissue put into it. The perfect normal fluids for the tissues of any animal are the fluids of the body (lymph and plasma) of the animal from which the tissue is taken. The lymph or serum of one species of animal may be far from normal for the tissues of another animal (see also § 499).

The commonly used artificial normal fluid is a solution of common salt (sodium chlorid) in water, the strength varying from $\frac{6}{100}$ to $\frac{9}{100}$ per cent. As indicated above, this normal salt or saline solution is employed in diluting dissociating liquids (§ 499).

§ 585. **Paraffin wax.** — A histologic laboratory requires two grades of paraffin for ordinary work. These are hard paraffin, melting at about 54° centigrade, and a softer paraffin melting at about 43° centigrade. Usually a mixture of equal parts answers very well. It is economical for a laboratory to buy the paraffin wax in cases of about 100 kilograms.

All paraffin for imbedding and sectioning should be filtered through two thicknesses of filter paper. For this, use a metal funnel, heat the paraffin very hot in a water bath, and then heat the funnel occasionally with a Bunsen flame. The warmer the room the easier it is to filter the paraffin.

Filter the paraffin into small porcelain pitchers. If the paraffin oven has a compartment large enough, it is well to keep one of the pitchers in the oven; then the paraffin remains melted and is ready for use at any time.

§ 586. **Picric-alcohol.** — This is an excellent hardener and fixer for almost all tissues and organs. It is composed of 500 cc. of water and 500 cc. of 95% alcohol, to which 2 grams of picric acid have been added. (It is a $\frac{1}{2}\%$ solution of picric acid in 50% alcohol.) It acts

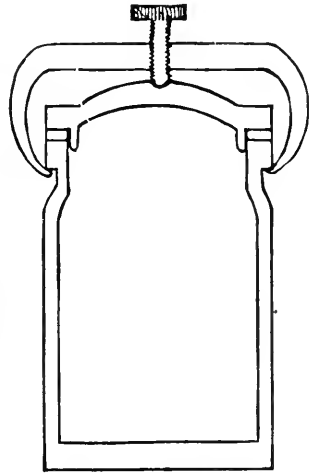

FIG. 214. SPECIMEN JAR WITH CLAMP.

quickly, in from one to three days. (Proc. Amer. Micr. Soc., Vol. XII (1890), pp. 120-122.)

§ 587. **Picro-fuchsin.** — 10 cc. of a 1% aqueous solution of acid fuchsin; 75 cc. of a saturated aqueous solution of picric acid. Stain deeply with hematoxylin first; then use the picro-fuchsin. Wash off the picro-fuchsin with distilled water. Mount in non-neutralized balsam, or better in acid balsam (balsam 50 cc., glacial acetic acid 5 drops). If the white connective tissue is not red enough, increase the amount of acid fuchsin.

§ 588. **Shellac cement.** — Shellac cement for sealing preparations and for making shallow cells is prepared by adding scale or bleached shellac to 95% alcohol. The bottle should be filled about half full of dry shellac; then enough 95% alcohol added to fill the bottle nearly full. The bottle is shaken occasionally and then allowed to stand until a clear stratum of liquid appears on the top. This clear, supernatant liquid is then filtered through filter paper or absorbent cotton, using a paper funnel (§ 545), into an open dish or a wide mouth bottle. To every 100 cc. of filtered shellac 2 cc. of castor oil may be added to render it less brittle. The filtered shellac will be too thin, and must be allowed to evaporate till it is of the consistency of thin syrup. It is then put into a capped bottle, and for use into a small spirit lamp (fig. 194). In case the cement gets too thick add a small amount of 95% alcohol or some thin shellac. The solution of shellac almost always remains muddy, and in most cases it takes a long time for the flocculent substance to settle. One can quickly obtain a clear solution as follows: when the shellac has had time to thoroughly dissolve, i.e., in a week or two in a warm place, or in less time if the bottle is frequently shaken, a part of the dissolved shellac is poured into a bottle and about one-fourth as much gasoline added and the two well shaken. After twenty-four hours or so the flocculent, undissolved substance will separate from the shellac solution and rise with the gasoline to the top. The clear solution may then be siphoned off or drawn off from the bottom if one has an aspirating bottle. (R. Hitchcock, Amer. Monthly Micr. Jour., July, 1884, p. 131.)

If one desires to color the shellac, the addition of a strong alcoholic solution of some of the coal tar colors is good, but is liable to dissolve

in the mounting medium when shellac is used for sealing. A small amount of lamp-black well rubbed up in very thin shellac and filtered is good to darken the shellac.

§ 589. **Silvering.** — Intercellular substance stains brown or black with nitrate of silver. Use $\frac{1}{4}$ or $\frac{1}{2}$ % aqueous solution on fresh tissue. Stain in the silver for 1 or 2 minutes; then expose to light in water till brown. Fix in 82 % alcohol or 5 % formaldehyde. One may stain afterward with hematoxylin for the nuclei; mount in glycerin, glycerin jelly, or in balsam.

§ 590. **Sudan III for fat.** — Sudan III, or azo-benzene-azo- β -naphthol, was introduced by Daddi into histology in 1896 (*Arch. Ital. de Biologie*, t. 26, p. 142), as a specific stain for fat. As it is soluble in all forms of fat and oils and in xylene, alcohol, etc., it is impossible to mount specimens in balsam after staining. As the fat of tissues is removed by the reagents used in the paraffin and collodion methods (see Ch. XI), only teased, free-hand, or frozen sectioned material fresh or fixed in some non-fat dissolving fixer can be used (Müller's fluid and 5 % formaldehyde are excellent). The tissues cut free-hand or with the freezing microtome or teased can then be stained with a saturated alcoholic solution of the Sudan. It stains all fat a brilliant red. Preparations can be preserved in glycerin or glycerin jelly. This stain is largely used in pathology.

Daddi used the substance to feed animals and thus to stain the fat which was laid down in the body while the Sudan was fed.

The fat in the body already deposited remains unstained. This substance then serves to record the deposit of fat in a given period. In 1907 Dr. Oscar Riddle fed Sudan to laying hens, and the fat in the layers of yolk laid down during the feeding was stained red (*Science*, XXVII, 1908, p. 495). For staining the yolks of hen's eggs the hen may be fed doses of 20 to 25 milligrams of the Sudan. Eggs so colored hatch as usual, and the chick in utilizing the colored yolk stains its body-fat pink (Susanna P. Gage).

§ 591. **Table Black.** — During the last few years an excellent method of dying wood with anilin black has been devised. This black is lusterless, and it is indestructible. It can be removed only by scraping off the wood to a point deeper than the stain has penetrated.

It must be applied to unwaxed or unvarnished wood. If wax paint or varnish has been used on the tables, that must be first removed by the use of caustic potash or soda or by scraping or planing. Two solutions are needed:

Solution A

Copper sulphate.....	125 grams
Potassium chlorate or permanganate.....	125 grams
Water	1000 cc.

Boil these ingredients in an iron kettle until they are dissolved. Apply two coats of the hot solution. Let the first coat dry before applying the second.

Solution B

Anilin oil.....	120 cc.
Hydrochloric acid.....	180 cc.
Water	1000 cc.

Mix these in a glass vessel, putting in the water first. Apply two coats without heating, but allow the first coat to dry before adding the second.

When the second coat is dry, sandpaper the wood and dust off the excess chemicals. Then wash the wood well with water. When dry, sandpaper the surface and then rub thoroughly with a mixture of equal parts turpentine and linseed oil. The wood may appear a dirty green at first, but it will soon become ebony black. If the excess chemicals are not removed the table will crock.

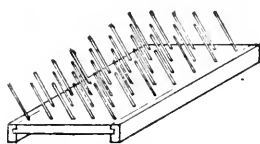

FIG. 215. DRYING RACK WITH INCLINED PEGS FOR BOTTLES.

An occasional rubbing with linseed oil and turpentine or with turpentine alone will clean the surface. This is sometimes called the Danish method, Denmark black or finish. See Jour. Ap. Micr., Vol. I, p. 145; Bot. Zeit., Vol. 54, p. 326; Bot. Gazette, Vol. 24, p. 66; Dr. P. A. Fish, Jour. Ap. Micr., Vol. VI, pp. 211-212.

§ 592. **Zenker's fluid.** — Müller's fluid (§ 581) 100 cc.; mercuric chlorid 5 grams. Just before using add 5 cc. of glacial acetic acid to each 100 cc. of the above. Fix fresh tissue 5 to 24 hours. Wash

out with running water 24 hours. Then place in 67% alcohol 1 day or more and finally preserve in 82% alcohol. Tissue fixed in Zenker's has mercuric crystals. They may be removed from the tissue by long treatment with iodine, or by putting the slide bearing the sections in iodized alcohol for half an hour or more.

This is an excellent fixer, combining the good qualities of mercuric chlorid and of the chromium compounds. Tissues fixed with this show well the red blood corpuscles. This is called Helly's fluid if the acetic acid is replaced by 5% formalin.

COLLATERAL READING FOR CHAPTER X

- LEE, A. B. — The Microtometist's Vade Mecum, 7th ed., 1913.
 KINGSBURY, B. F. — Histological Technique, 1915.
 MANN, G. — Physiological Histology, 1903.
 EHRLICH, P., ET AL. — Enzyklopaedie der Mikroskopischen Technik, 1910.
 WRIGHT, SIR A. E. — Principles of Microscopy, 1907.
 CARPENTER-DALLINGER. — The Microscope and Its Revelations, 1901.
 SPITTA, E. J. — Microscopy, 1907.
 Anatomical Record.
 Journal of the Royal Microscopical Society.
 Transactions of the American Microscopical Society.
 Journal of Experimental Zoology.
 Botanical Gazette.
 BOYER, C. S. — The Diatomaceae of Philadelphia and Vicinity, 1916.
 DUDLEY AND THOMAS. — Manual of Plant Histology, 1894.
 CHAMBERLAIN, C. J. — Methods in Plant Histology, 1916.
 STEVENS, W. C. — Plant Anatomy, 1915.
 EWART, A. J. — Protoplasmic Streaming in Plants, 1903.
 BERNARD, CLAUDE. — Leçons sur les Phénomènes de la Vie communs aux Animaux et aux Végétaux. Two vols. 1878-1879.
 NEEDHAM & LLOYD. — The Life of Inland Waters, 1916. This is a most important work for all interested in water forms.

CHAPTER XI

FIXING AND THE PRESERVATION OF TISSUES, ORGANS, AND ENTIRE ORGANISMS. IMBEDDING, SECTIONING, STAINING, AND MOUNTING FOR THE MICROSCOPE. SERIAL SECTIONS. MODELS

§ 600. Apparatus and material for Chapter XI.

1. Bottles and vials for specimens and tissues (fig. 196-197, 211-214).
2. Dissecting instruments.
3. Fixing agents and alcohol.
4. Washing apparatus (fig. 216-217).
5. Clearing agents and imbedding material.
6. Infiltrating oven and spreading plate (fig. 219-220, 226-230).
7. Section razors and knives (fig. 218, 223).
8. Microtomes.
9. Hones and strops for sharpening knives.
10. Slide trays or cylinders for ribbons of sections (fig. 206-207).
11. Slides and cover-glasses.
12. Slide baskets and glass-stoppered jars (fig. 231-232).
13. Staining liquids and mounting media.
14. Modeling material, — wax and blotting paper.
15. Apparatus for drawing sections for models (§ 671-681).

§ 601. **Fixation and preservation of organs and tissues.** — By fixing or fixation in histology is meant the preparation of fresh tissues, organs, embryos or small adult animals usually by means of some chemical mixture, called a “fixer,” so that the organ, etc., as a whole and the elements or cells composing it shall retain as nearly as possible the morphologic characters present during life. The more perfect the fixer the nearer will be the preservation of all structural details.

Unfortunately no single “fixer” preserves with equal excellence all the structural details, and therefore it is necessary to prepare the fresh tissue in several different ways and to make a composite of the structural appearances found, thereby approximating the actual structure present in the living body. Changes are so rapid after death that the fixation should begin as soon as possible. For the most perfect fixation the living tissue must be put into the fixer.

With one of the larger animals where the whole animal is to be

used for microscopic study it is a great advantage to bring the fixer in contact with all parts of the body quickly, and that is done by

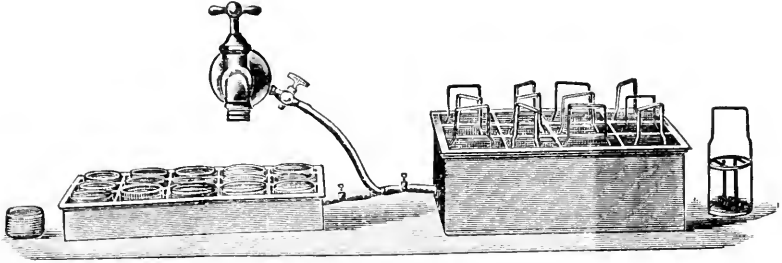

FIG. 216. WASHING BOXES FOR TISSUES FIXED IN A LIQUID CONTAINING MERCURIC CHLORID.

(From the Journal of Applied Microscopy).

T Small stop cock or pet cock in the usual water faucet so that a small stream may be drawn without interfering with the large faucet.

Only the larger trays are now used, the perforated inner tray being deep or shallow as needed.

washing out the vascular system with normal salt solution and then filling the vascular system with the fixer. This method of "*fixation*

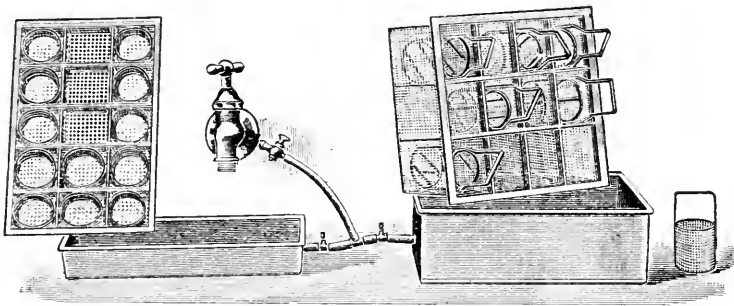

FIG. 217. METAL WASHING BOXES FOR TISSUES FIXED IN A LIQUID CONTAINING MERCURIC CHLORID.

(From the Journal of Applied Microscopy).

The deeper box is now used only and depending on the size of the pieces to be washed the shallow or the deep perforated trays and tissue baskets are used. The deep tray serves for washing slides with Weigert and other stains which must be in water a long time.

by injection" is of great importance in the histology of animals which are large enough to inject.

If the animal is too small for injection or one wishes only a small part of a larger animal, then the pieces for fixation should be small, say one to three cubic centimeters. Often as for Flemming's fluid (§ 567) and for several others it is better to use pieces 2 to 5 cubic millimeters in volume.

Large, solid organs must be cut into several pieces if the whole is needed. For hollow organs the cavity may be filled with the fixer and the organ placed in a vessel of the same.

The amount of fixer should be 10 to 50 times that of the piece of tissue.

Of the fixers given under "Preparation of Reagents," picric alcohol, formaldehyde, and Zenker's fluid are suitable for almost every tissue and organ. Formalin has the advantage of having strong penetration; hence it preserves whole animals fairly by immersing after filling the abdominal and thoracic cavities. Formaldehyde is excellent where a study of fat is in question, and it is much used as a fixer where frozen sections are desired (§ 609). Remember the necessity of removing mercury from sections of tissues fixed with a mercuric fixer (fig. 216-217).

§ 602. Mechanical preparation of tissues, etc., for microscopic study. — A limited number of objects in nature are small enough and transparent enough, and a limited number of the parts of higher animals are suitable for microscopic study without mechanical preparation except merely mounting them on a microscopic slide. Usually the parts of animals are so large and so opaque that the histologic elements or cells and their arrangement in organs can only be satisfactorily studied with a microscope after the tissue, organ, etc., have been teased apart with needles, or sectioned into thin layers.

MICROTOMES AND SECTION KNIVES

§ 603. The older histologists, those who laid the foundations and whose understanding of the finer structure of the body was in many ways superior to the knowledge possessed by workers at the present time, did their mechanical preparation with needles and with sharp

knives held in the hand. They dealt also with fresh tissue more largely than we do at the present day, and learned also to distinguish tissues by their structure rather than by their artificial coloration.

It was not, however, on account of the lack of elaborate mechanical devices for sectioning and complicated staining methods of the present day, but because they put intelligence and zeal into their work that made them so successful.

If the reader is interested in the mechanical means for sectioning he is referred to Dr. C. S. Minot's papers on the history of the microtome in the *Journal of Applied Microscopy*, Vol. VI, and to Gilbert Morgan Smith's article in the *Transactions of the American Microscopical Society*, Vol. XXXIV, 1915, on the Development of Botanical Microtechnique, pp. 71-129, 16 pages of bibliography; 18 figures, showing early microscopes and microtomes.

§ 604. **Types of microtomes.** — There are two great types: (1) The early type in which the preparation to be sectioned is held mechanically and moved up by a screw, the section knife being held in the hand and moved across the object, usually with a drawing motion as in whittling.

(2) The mechanical type, in which both specimen and knife are mechanically held and guided, and the operator simply supplies power to the machine, or when an electric motor is used the operator starts and stops the machine and uses his hands in taking off the ribbon as it is cut. The ribbon is wound on a cylinder or cut into the proper lengths for the slide trays (fig. 206-207).

In the highest types of the second class — *automatic microtomes* — the operator only needs to put the knife and specimen in position and sections of any thickness and any number may be produced in a short time. A skilled and experienced person can get better results here as well as with free-hand sectioning or the hand microtome. Even automatic machines work better for skilled workmen.

In some forms the knife of these automatic microtomes is fixed in position and the object to be sectioned moves, while in other forms the object to be sectioned remains fixed and the knife moves. Furthermore, for sectioning paraffin, the knife meets the object like a plane (straight cut), while for collodion sectioning the knife

is set obliquely and there results an oblique or drawing cut, as in whittling.

§ 605. **Section knives.** — A section knife should have the following characters. (1) The steel should be good. (2) The blade should be slightly hollow ground on both sides. Why some makers persist in grinding one side flat is a mystery. (3) The edge of the knife should be straight, not curved as in a shaving razor. (4) The back should be parallel with the edge. (5) The blade should be long, 12 to 15 centimeters, as it takes no more time or skill to sharpen a large than a small knife. (6) The blade should be heavy. There was formerly a fashion of making very thin-bladed section knives, but that is a

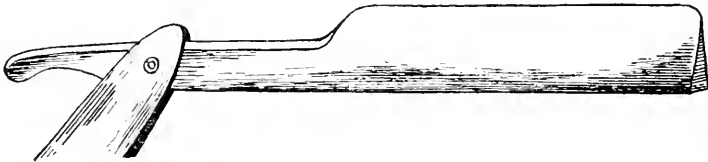

FIG. 218. SECTION RAZOR WITH HEAVY BLADE HAVING STRAIGHT BACK AND EDGE.

great mistake, for the thin blade bends and vibrates in cutting firm tissue and large pieces. There is no possible advantage in a thin-bladed section knife for microtome work, but much disadvantage from the lack of rigidity. (See the catalogues of microtomes and section knives by the Bausch & Lomb Optical Co. and the Spencer Lens Co.)

§ 606. **Sharpening section knives; hones and strops.** — Perhaps it should be taken for granted that any one would appreciate the impossibility of making good sections with a dull section knife, but experience teaches the contrary. Students are prone to believe that with one of the elaborate automatic microtomes, good sections may be made with any kind of an edge on the knife. It is forgotten that *the knife is the most important part*; all the other mechanism is simply its servant.

For sharpening, select a fine yellow Belgian hone, and a very fine Arkansas hone. As a rule hones from the factory are not sufficiently

plane. They may be flattened by rubbing them on a piece of plate glass covered with moderately fine emery or carborundum wet with water. Round the corners and edges of the hones on the plate glass or on a grindstone. In using the Belgian hone for sharpening knives, wet the surface well with a moderately thick solution of soap. With the Arkansas stone use some thin oil — xylene or kerosene mixed with a little olive oil or machine oil.

Honing. Before honing a section knife, make sure that the edge is smooth; that is, that it is free from nicks. Test this by shaving off the surface of a block of paraffin. If nicks are present the cut surface will show scratches. It is advisable also to look at the edge of the knife with a magnifier and with a low power (50 mm.) objective. If nicks are present remove them by drawing the edge along a very fine Arkansas hone.

A saw edge may be all right for rough cutting and for shaving razors, but if one wishes to get perfect sections 1μ to 10μ in thickness a saw edge will not do. In removing the nicks one should of course bear on very lightly. The weight of the knife is usually enough.

In honing use both hands; draw the knife, edge foremost, along the hone with a broad curved motion. In turning the knife for the return stroke, turn the edge up, not down. Continue the honing until the hairs on the arm, wrist, or hand can be cut easily or until a hair from the head can be cut within 5 mm. from the point where it is held. The sharper the knife becomes the lighter must one bear on. One should also use the finest stone for finishing. If one bears on too hard toward the end of sharpening, the edge will be filled with nicks.

In honing and stropping large section knives, there has come into use during the last few years the so-called "honing backs." These elevate the razor slightly, so that the wedge is blunter and one does not have to grind away so much steel.

Strop. A good strop may be made from a piece of leather (horsehide) about 50 cm. long and 5 to 6 cm. wide, fastened to a board of about the same size.

The strop is prepared for use by rubbing into the smooth surface

some carborundum powder, i.e., 60-minute carborundum, that which is so fine that it remains in suspension in water for 60 minutes, or one may use diamantine or jewelers' rouge.

Stropping. With the back foremost draw the knife lengthwise of the strop with a broad sweep. For the return stroke turn the edge up as in honing. Continue the stropping until a hair can be cut 1 to 2 centimeters from where it is held. (See also the hones and strops and the methods of procedure recommended in the catalogues of microscopical manufacturers.)

§ 607. **Free-hand sectioning.** — To do this one grasps the section knife in the right hand and the object in the left. Let the end to be cut project up between the thumb and index finger. One can let the knife rest on the thumb or index finger nail and with a drawing cut make the section across the end of the piece of tissue. By practice one learns to make excellent sections this way. If the whole section is not sufficiently thin, very often a part will be and one can get the information needed.

§ 608. **Sectioning with a hand or table microtome.** — The tissue is held by the microtome and moved up by means of a screw. The knife rests on the top of the microtome and is moved across the tissue by the hand. Microtomes of this kind are excellent. No one need wait for expensive automatic microtomes to do good sectioning. With a good table microtome, the knife being guided by the hand or hands of the operator, he can make straight cuts as for paraffin sectioning, or drawing cuts as for collodion work.

§ 609. **Sectioning with a freezing microtome.** — In this method of sectioning the tissue is rendered firm by freezing and the sections are cut rapidly by a planing motion as with paraffin. Now the most usual freezing microtome is one in which the freezing is done with escaping liquid carbon dioxid. The knife should be very rigid. A carpenter's plane blade is often made use of. The tissue may be either fresh or fixed. If alcohol has been used it must be soaked out of the tissue by placing it in water. Sometimes tissues are infiltrated a day or two in thick gum arabic mucilage before freezing. Drop a little thick mucilage on the top of the freezer, put the tissue in the mucilage, and turn on a small amount of carbon dioxid. It will

soon freeze the mucilage and the tissue, as shown by the white appearance. When frozen, cut the tissue rapidly. It is well to have an assistant turn the feed screw up while the sections are cut. When 20 or 30 sections are cut place them in water or normal salt solution. This is a rapid method of getting sections much used in pathology where quick diagnoses are demanded. In normal histology the freezing microtome is used mostly for organs or parts of greatly varying density. For example, if one wishes sections of the finger and finger nail, this apparatus offers about the only means of getting good sections. In that case the bone is decalcified before trying to make the sections (§ 559).

Frozen sections are also very useful for demonstrating the presence of fat by staining with Sudan III.

THE PARAFFIN METHOD OF SECTIONING

§ 610. **Object of the paraffin.** — In the early periods in histology great difficulty was encountered in making good sections of organs and parts of organs, because the different tissues were very unlike in density. At first tallow and beeswax, elder pith, liver, and various other substances were used to enclose or surround the object to be cut. This gave support on all sides, but did not render the object homogeneous. In the early sectioning, a great effort was made to keep all imbedding material from becoming entangled in the meshes of the tissue. This was guarded against by coating the object with mucilage, and hardening it in alcohol. This mucilage jacket kept the tissue free from infiltration by the imbedding mass and itself was easily gotten rid of by soaking the sections in water.

A great advance was made when it was found that the imbedding mass could be made to fill all the spaces between the tissue elements and surround every part, the tissue assuming a nearly homogeneous consistency, and cutting almost like the clear imbedding mass. Cocoa butter was one of the first substances to be used for thus "infiltrating" the tissues. The imbedding mass must usually be removed before the staining and mounting processes; but in staining for glycogen by the iodine method, the stain is applied before the paraffin is removed (§ 575).

§ 611. **Infiltration of the tissue with imbedding mass.** — The tissue to be cut in this way is first fixed by one of the fixers used for histology. Several good ones are given in sections 568, 586, 592, 601.

(A) The tissue is then thoroughly dehydrated by means of 95% and absolute alcohol. For most objects, especially embryos and other

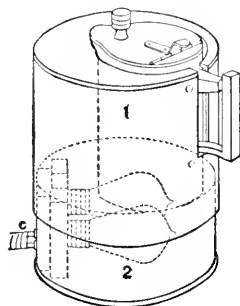

FIG. 210. KINGSBURY'S PARAFFIN MELTING OVEN.

(From the Anatomical Record).

1 Upper part of the oven containing the covered pitcher for the paraffin.

2 Lower part containing the incandescent lamps and supply cable (c). The oven is well insulated by asbestos. Depending on the temperature of the room, one or both lamps can be used to keep the paraffin melted.

colorless objects, it is best, during the dehydration, first to use dilute alcoholic eosin (§ 562), as the most delicate part shows when one cuts the sections. Leave the piece of tissue to be cut overnight in alcoholic eosin, and a few hours in uncolored 95% alcohol, using 20 times as much alcohol as tissue. For the final dehydration it should be left in absolute alcohol four or five hours or overnight, depending on the size of the object.

(B) Remove the alcohol by a solvent of the imbedding mass; that is, by some substance which is miscible with both alcohol and the imbedding mass. Cedar-wood oil is most generally used, but pure xylene, chloroform, and carbol-xylene are also used, — the chloroform and carbol-xylene when osmic acid fat is to be retained in the tissue.

Leave the tissue in cedar oil or other clearer until the tissue sinks and the thin parts of the specimen become translucent. If the tissue does not sink after a time it means that the tissue was not dehydrated.

Of course this does not apply to lung or other spongy tissue containing much air. It is well to change the cedar oil or other clearer once. The used cedar oil may be left in an open bottle for the evaporation of alcohol and used over and over again.

(C) Displace the cedar oil or other clearer by melted paraffin wax. When the tissue is saturated with the oil transfer it to an infiltrating dish (fig. 220) containing melted paraffin. Place in a paraffin oven (fig. 220) and keep the paraffin melted for from two hours to three

days, depending on the size and character of the piece to be imbedded. If the tissue was thoroughly dehydrated and well saturated with cedar oil, the melted paraffin permeates the whole piece.

§ 612. **Imbedding in paraffin wax.** — When the object is thoroughly infiltrated imbed as follows: Make of strong writing paper a box considerably larger than the piece to be imbedded. Nearly fill the box with paraffin wax, place on a copper heater (fig. 226), and allow to remain until bubbles appear in it.

Put the box on cold water until a thin stratum of paraffin solidifies on the bottom. Take the piece of tissue from the infiltrating dish (fig. 220) and arrange in the box for making sections in a definite direction. Add hot paraffin, if necessary, and then place the box on cold water. The more rapid the cooling, the more homogeneous will be the block containing the tissue to be cut. For the best imbedding it is well to drop 95% alcohol on the surface as soon as a film has formed in cooling. In warm climates where cold water is not easy to procure for cooling the blocks, one may float the paper box on 95% alcohol and with a pipette (fig. 234) drop strong alcohol on the sides of the box and on the top of the paraffin as soon as a surface film has formed.

It is very desirable to mark on the box the name of the imbedded object and to indicate which end or face is to be cut (see also § 657).

§ 613. **Fastening the block to a holder.** — Use one of the block holders or object discs furnished with the microtome, or a short stove bolt (fig. 222). Heat the larger end and press the paraffin block against the hot metal until it melts the paraffin. Hold the two together while cold water flows over them. When cold the block is firmly cemented to the holder. Pains should be taken to have the axis of the block parallel with the long axis of the holder; and one

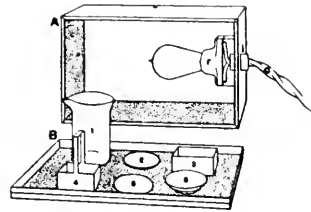

FIG. 220. ELECTRIC INFILTRATING BOX AND SPREADING PLATE.

(From the Anatomical Record).

A The box with a metal spreading plate on top.

r Porcelain receptacle, *i* porcelain insulation where the cable (*c*) traverses the wall of the box.

B Base or tray holding the infiltrating dishes and the beaker for melted paraffin.

should not cut the block so short that the holder comes in contact with the tissue when the paraffin and holder are cemented together.

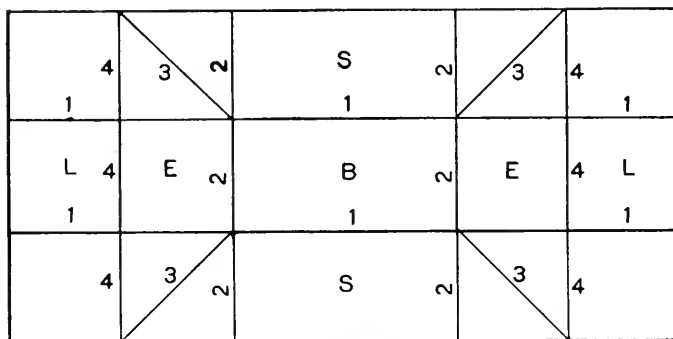

FIG. 221. DIAGRAM SHOWING HOW TO MAKE A PAPER BOX FOR IMBEDDING.

- 1, 1, 1, Lines for the first folds; these make three longitudinal strips.
 2, 2, 2, Lines for the second folds; these make three transverse strips.
 3, 3, 3, Lines showing where the corner folds are made.
 4, 4, 4, The folds for the projecting end or label.
B Bottom, *S* Side, *E* Ends and *L* Label of the box. The bottom occupies $\frac{1}{3}$ of the area.

A clamp is sometimes used for holding the paraffin block.

§ 614. **Trimming the end of the block for sectioning.** — Sharpen the end to be cut in a pyramidal form, being sure to leave 2 milli-

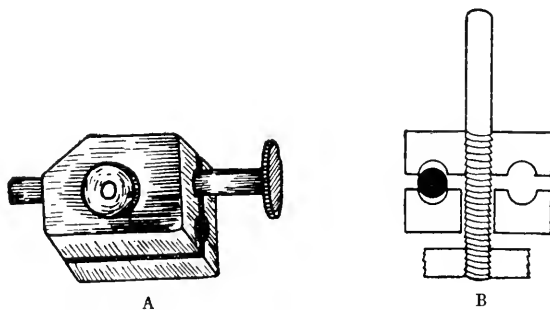

FIG. 222. CLAMP FOR STOVE BOLTS TO BE USED AS HOLDERS FOR PARAFFIN BLOCKS.

A Face and *B* Sectional view with a stove bolt in position.

meters or more of paraffin over the tissue at the end as well as on the sides. The block is trimmed in a pyramidal form, so that it will be rigid. Take particular pains that the opposite faces at the end of the block are parallel and all the corners right angles.

In some laboratories, Dr. McClung's for example, a cubical block of metal attached to a rod is placed in the knife holder of the microtome and the four sides of the imbedding mass trimmed with great exactness by the use of a straight-edged scalpel, or better by a small chisel, the cube of metal serving as a guide. As the metal cube can be slid along in the knife holder, and the imbedded tissue can be raised and lowered by turning the wheel of the microtome, imbedding masses of large and small sizes can be trimmed by the same metal guide. This guide for trimming is a great help in getting straight ribbons, and consequently good series.

§ 615. **Making paraffin sections.** — Put the paraffin block or the metal holder in the clamp of the microtome. Arrange the block so that one side of the pyramidal end is parallel with the edge of the knife; then tighten the clamp; and if an automatic microtome is used, make sure that the section knife is also tightly clamped by the proper set screws. It is well to have the knife lean slightly toward the paraffin blocks.

The knife edge meets the paraffin squarely, as in planing. The thickness of section is provided for in the automatic microtome by the indicator, which may be set for any desired thickness, or one can turn up the screw by hand in the table microtome. The paraffin and its contained tissue are cut in a thin shaving. If the tissue was stained *in toto* with eosin, as suggested in § 611 A, it is



FIG. 223. SCALPEL BLADES.

1, 2 with curved edges for cutting ribbons; 3, with straight edge for trimming paraffin blocks.

marked out with great clearness in the containing paraffin (see also § 657).

As succeeding sections are cut they push along the previous sections, and if the hardness of the paraffin is adapted to the temperature where the sectioning is done, the edges of the successive sections will be soldered as they strike. This produces a ribbon, as it is called,

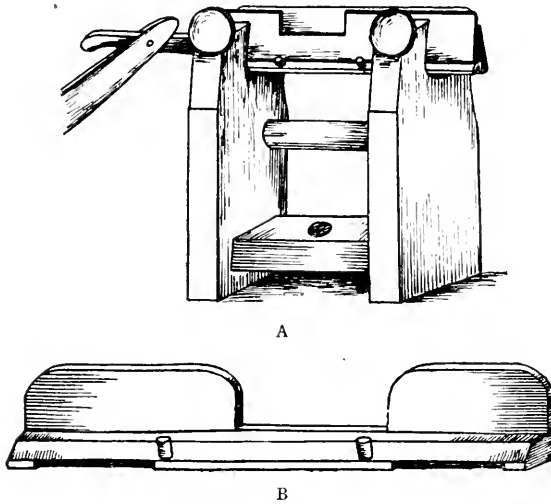

FIG: 224. SUPPORT OF THE MICROTOME KNIFE SO THAT THE MOST OF THE EDGE CAN BE USED.

and if the paraffin block has been properly trimmed at the end the ribbon will be straight and even. If the ribbon is curved sideways it indicates that one side of the block is thicker than the other and the sections are slightly wedge shaped.

If the paraffin is too hard for the room temperature and for a given thickness of section, the sections will curl; if it is too soft, the sections will crumple.

The thinner the sections the harder should be the paraffin or the cooler the sectioning room; and the thicker the sections and the larger the object to be cut, the softer can be the paraffin and the higher the temperature. If, then, the sections do not ribbon, make thinner

sections or work in a warmer place. If the sections crumple, make thicker sections or work in a cooler room. Of course one can reimbed in a more suitable hardness of paraffin.

In the season when steam radiators are used one can get almost any desired temperature by sectioning nearer or farther from the radiator.

In the winter it is a good plan to warm the microtome and section knife before sectioning. This can be very easily done by putting a cloth over the radiator and the microtome something like a tent.

§ 616. **Electrification of the paraffin ribbons.**—

Some days there is such an accumulation of static electricity in cutting the ribbons that they jump toward anything brought

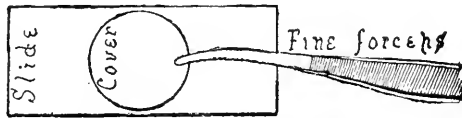

FIG. 225. FINE FORCEPS FOR HANDLING COVERGLASSES, RIBBON SECTIONS, ETC.

near them. This is very annoying and liable to be so destructive to many of the sections that serial work cannot be done with safety.

Many devices have been tried to overcome this difficulty, like burning a gas jet near the microtome, boiling water near the apparatus, etc., but the safest way is to wait for more favorable conditions.

To overcome this electrification, Dixon (Jour. Roy. Micr. Soc., 1904, p. 590) recommends fastening a 5-milligram tube of radium bromide on the knife near where the sectioning is done. The radium ionizes the air and renders it a good conductor, and then the static electricity cannot accumulate. I have not been able to try this method.

§ 617. **Storing paraffin ribbons.**— The most convenient method for caring for the ribbons as they are cut is to place them on a tray (fig. 206-207) lined with a sheet of white paper. It is important to write on the paper full data, giving the name of the tissue, the thickness of the sections, the date, etc. It is well also to number the ribbons and to indicate clearly the position of the first section or the beginning of the ribbon.

Ribbons of sections on a tray should be covered by another tray if one wishes to carry them to another room. The slightest gust of air sends them flying.

Ribbons on trays may be kept a long time, three or four years at least, if they are stored in a cool place. The sections do not flatten out quite as well after standing a long time as they do soon after they are made.

§ 618. **Paraffin ribbon winder.** — As most embryos and many organs which are to be cut entire make ribbons much longer than the slide tray, it is necessary to cut the ribbons into segments usually as they are made. If one grasps the ribbon with fine forceps and carries it out from the microtome it is liable to break from its weight when it gets long. The spread of the arms prevents a very long section also. If one has to stop in making a series there is liable to be a section too thin or too thick when one begins again, and frequently a section is lost.

To overcome this very radical defect McClung and Hance have devised what they call a "Paraffin Ribbon Winder." This consists of a cylinder (mailing box on an axle) on which the ribbon is wound as cut, just as thread is wound on a spool. (For figures and descriptions, see *Anatomical Record*, June 20, 1916, pp. 523-526; *Trans. Amer. Micr. Soc.*, Vol. XXXII, 1913, pp. 297-299.)

§ 619. **Spreading the sections on water.** — Paraffin sections are almost invariably slightly wrinkled or folded in cutting. To remove the wrinkles one takes advantage of the expansion of paraffin when it is warmed. The sections may be floated on warm water, when they will straighten out and become smooth, or the usual method is to stretch them on the slide upon which they are to be finally mounted.

By spreading sections on a wet slide a double operation is per-

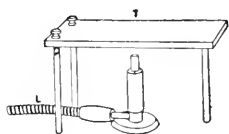

FIG. 226. LEVELING METAL TABLE FOR SPREADING SECTIONS AND FOR IMBEDDING IN PARAFFIN.

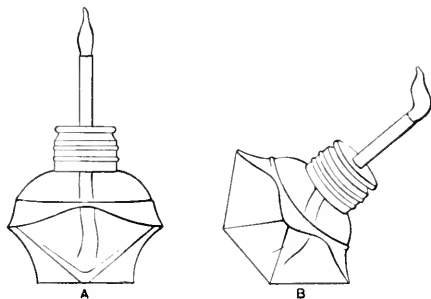

FIG. 227. ALCOHOL LAMP IN A VERTICAL AND AN INCLINED POSITION.

formed, viz.: the sections are made smooth and they are also fastened to the slide. Put a minute drop of albumen fixative on the middle of a slide and with the ball of one finger spread it over the slide, making a thin even layer. It cannot be too thin. It is liable to stain if it is too thick.

With a pipette (fig. 234) put several drops of water on the slide and then place a piece of ribbon on the water; or put the sections on the albumenized slide and add the water afterward. Heat the slide carefully over a spirit lamp or gas flame, being sure not to melt the paraffin. As the water warms the paraffin expands and stretches the sections out smooth. A copper heating plate is good for spreading sections; but the electric spreaders are best (fig. 226-230).

§ 620. **Drying the sections.** — After the sections are spread, drain off most of the water, arrange the sections with

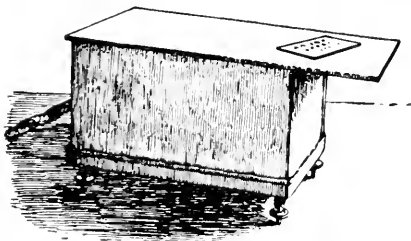

FIG. 229. KINGSBURY'S ELECTRIC SPREADING PLATE AND INFILTRATING BOX.

The top projects and any temperature is obtainable. If need be the projecting end can be heated with a Bunsen burner or an alcohol lamp. The wiring is as shown in Fig. 220.

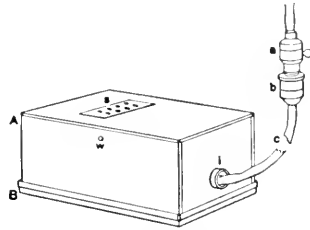

FIG. 228. ELECTRIC SPREADING PLATE AND INFILTRATING BOX. (From the Anatomical Record).

A The upper part of the box on which is the spreading plate.

B Base, or tray in which the infiltrating dishes are placed (see Fig. 220).

S A slide with sections being spread.

a, b The lamp socket and separable plug and the supply cable.

i Insulation where the cable passes into the box.

a needle or scalpel, and place the slide in one of the trays (fig. 206-207). Allow it to remain overnight or preferably longer. The longer the drying in air the more surely do the sections adhere to the glass slide; or use the drying oven (fig. 244).

If one is in haste to take the succeeding steps in the preparation, the slide may be dried by putting it into a drying oven at 38° to 40° C. for

half an hour or more. The slower drying in air is better if one has plenty of time.

Some tissues are very difficult to get perfectly smooth, as just described. If fine wrinkles persist, one can sometimes overcome the difficulty by letting the slide cool and then covering with a piece of fine tissue paper slightly moistened; press down firmly with the ball

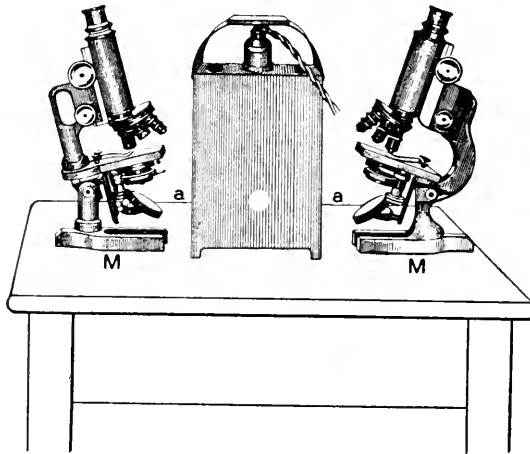

FIG. 230. LANTERN WITH DAYLIGHT GLASS. THE TOP IS FLAT AND SERVES WELL FOR SPREADING SECTIONS.

(From the Anatomical Record).

of the finger on the sections. Then take hold of the edge of the paper and roll it off the sections. Unless one is careful the sections are liable to come away with the paper instead of adhering to the slide.

As the water dries out the spread sections come in very close contact with the glass and adhere quite firmly to it. The thinner the sections the more tightly do they stick. This makes it possible to perform the rest of the operations on the slide. One has to be careful not to let strong currents strike the sections.

§ 621. **Deparaffining in xylene.**—This is accomplished by using a solvent of paraffin. The best and safest one to use in a laboratory

is xylene. Benzine, gasoline, and even kerosene are used, but xylene is a powerful solvent of paraffin, does not injure the tissue, and is not very inflammable, due to the large amount of carbon in its

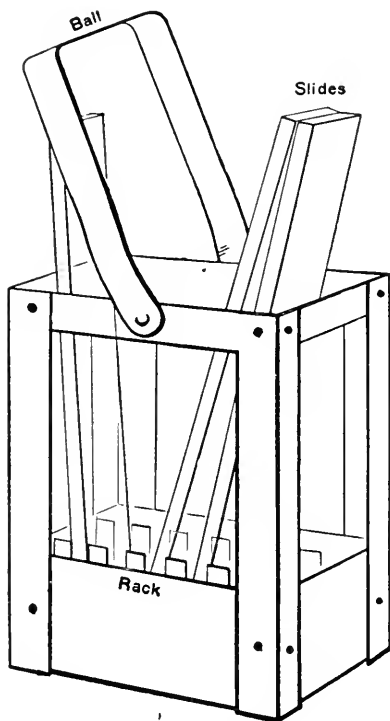

Fig. 231.

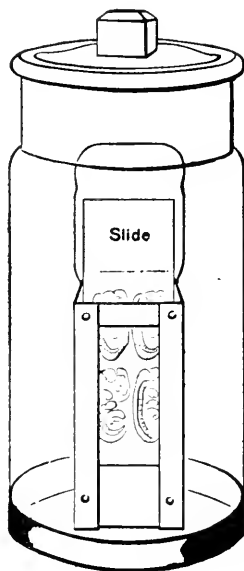

Fig. 232.

FIG. 231. SLIDE BASKET OR RACK FOR HANDLING SERIAL SECTIONS.

FIG. 232. GLASS STOPPERED SPECIMEN JAR WITH A SLIDE BASKET OR RACK WITH A SPECIMEN IN PLACE.

molecule (see § 552) and the consequent high boiling point, 136° C. (§ 450).

It requires only a few minutes to dissolve paraffin from the sections, but a day or more in the xylene does no harm.

When the paraffin is removed the staining and other operations necessary for a completed preparation may be undertaken (see for these § 630).

§ 622. **Collodionizing the sections.** — Except for carmine stains and perhaps some others, collodion remains practically colorless. While the sections remain quite firmly attached to the slide after they have been spread and dried, thick sections are liable to come off in the many processes of staining, and if one has many sections on a slide some of them may become loosened. To avoid this, the sections are covered with a delicate layer of collodion, which holds them down to the slide. The early method was to use a soft brush and paint a thin film over the dried sections before they were deparaffined. Now the sections are deparaffined, and then, after draining the xylene from the slide, 10-15 seconds, it is put into a bottle containing $\frac{3}{4}$ % collodion (§ 556). In a minute or more the collodion displaces the xylene and penetrates the sections and forms a delicate veil over their free surface. No harm is done by leaving the sections in the collodion a considerable time, but a minute or two is sufficient. The slide is removed, allowed to drain for half a minute, and then put into a jar of 67% alcohol (fig. 232). The alcohol fixes the collodion and removes the ether. As the 67% alcohol does not hurt the tissue, it may stay in the jar a day or more, if desired, but half an hour suffices.

The sections are now ready for the subsequent staining and other operations to make a finished slide. One has to remember that if mucicarmine (§ 549) is to be used in staining, the preparation must not be collodionized, as carmine stains collodion.

§623. **Steps in order for the paraffin method.** —

Name	No.
Animal.....	Absl. alc..... Cedar oil.....
Date.....	Infilt.....
Fixer.....	Temp. bath..... Imbed. in.....
Time of fix.....	Sections cut..... μ 's.....
Washed in water.....	Temp. room.....
67% alc..... 82% alc.....	Stains.....
Decalc. § 398..... 67, 82% alc.....
<i>In toto</i> stain.....	Mtd. in.....
Washed in.....	Remarks.....
67% alc..... 82% alc.....
95% alc. and cosin.....

THE COLLODION OR PARLODION METHOD OF SECTIONING

§ 624. **Collodion method.** — In this method the tissue is thoroughly permeated with a solution of collodion, which is afterward hardened. Unlike the paraffin of the paraffin method, the collodion (§ 555a) is not subsequently removed from the tissue, but always stays in the sections. It is transparent and does no harm.

The fixing and dehydration with 95% alcohol is the same as for the paraffin method.

The paraffin method gives thinner sections than the collodion method and for series and large numbers of sections is superior.

The collodion method requires no heat for infiltration, and it does not render the firmer forms of connective tissue so hard and difficult to cut. It is especially adapted for making sections of large pieces of tissue or organs and when thick sections are desired. It is not easy to cut sections less than 10μ with collodion, while with paraffin it is possible to make good ribbons of small objects of delicate texture 2μ to 3μ in thickness. With a very sharp knife and small delicate object, and one of the better forms of microtomes, one can cut short paraffin series in 1μ sections and get perfect ribbons.

In plant histology paraffin is used for cytologic work, and by many whenever possible. Collodion must be used for the hard tissues and is used by preference in some laboratories. (See references in the collateral reading at the end.)

Collodion sectioning is sometimes denominated the *wet method*, as the tissue and sections must always be wet with some liquid, while the paraffin method is called the *dry method*, as the tissue once infiltrated with paraffin keeps in the air indefinitely and in cutting the sections no liquid is used.

§ 625. **Infiltration with ether alcohol.** — Transfer the piece of tissue to be cut from 95% alcohol to a mixture of equal parts of sulphuric ether and 95% or absolute alcohol, and leave in this for a few hours or a day or more, as is most convenient. This is to soak the tissue full of a solvent of the collodion.

§ 626. **Infiltration with $1\frac{1}{2}\%$ collodion.** — Pour off the ether alcohol from the tissue and add $1\frac{1}{2}\%$ collodion. Leave in this overnight or longer if the piece of tissue is large.

§ 627. **Infiltration with 3% collodion.** — Pour off the 1½% collodion and put in its place 3% collodion. Leave the tissue in this half a day or longer.

§ 628. **Infiltration with 6% collodion.** — Pour off the 3% and add 6% collodion to the piece of tissue. For complete infiltration with this thick collodion leave the tissue in it for one day at least. If the object is large it is advantageous to leave it in for a week or two.

§ 629. **Infiltration in strong collodion.** — Many workers recommend as thick a solution as can be made for the final infiltration, and a long stay (2-3 weeks) in the infiltrating liquid.

Many also recommend a great many steps in the process, commencing with 1% and gradually passing up through increasing strengths till the thickest is reached.

§ 630. **Imbedding on a cork or block.** — For imbedding small pieces use a piece of wood (deck plug), vitrified fiber, glass, or a good cork for a holder and cover the end with 6% collodion and let it get well set in the air; then put the piece of tissue on the holder and drop 8% collodion upon it at intervals until it is well covered all around. If one takes considerable time for this the collodion thickens greatly in the air. This is an advantage, for it gives a denser block for sectioning. After the collodion is pretty well set, place holder and tissue in a vessel with chloroform to harden. One can put the preparation into the chloroform, or, if the vessel is tight, it may be above the chloroform, the vapor then acting as the hardener.

§ 631. **Imbedding in a paper box.** — If the object is of considerable size it is best to use a paper box for imbedding, as with paraffin. If a very small amount of vaseline is rubbed on the inside of the box, it prevents the collodion from sticking to the paper (fig. 221, § 657).

Put first some of the thick collodion in the box and let it remain in the air until nearly solid, 2 to 3 minutes. Then arrange the specimen to be cut as for imbedding in paraffin, and gradually add thick collodion until the object is well covered. Let the box stand for a few minutes in air; then place it in a dish like a Stender dish and pour some chloroform on the bottom of the dish. Cover and the collodion will harden, partly by the chloroform vapor and partly by that which soaks through the paper. It is well to change the chloroform at

least once. The used chloroform will contain some ether alcohol, but is good for killing animals.

After 24 or 48 hours the collodion should be firm all through. Then it is placed in 67% alcohol where it may be left a day or more. If it is to be left an indefinite time the 67% alcohol should be changed for 82%.

§ 632. **Sectioning by the collodion method.** — For this one can use a table microtome or one of the sliding microtomes. The sections are made with a knife set obliquely and hence with a drawing cut.

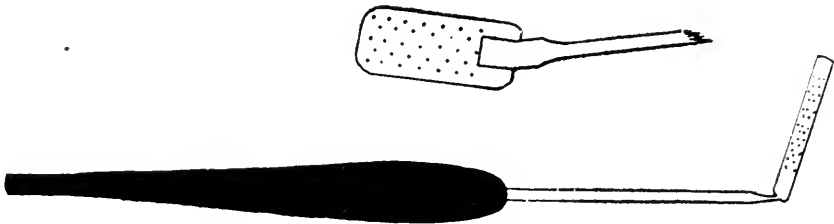

FIG. 233. PERFORATED SECTION LIFTER FOR HANDLING SINGLE COLLODION OR FROZEN SECTIONS.

The holder with the small piece of tissue is clamped in the microtome and arranged as desired; then the sections are made with an oblique knife which is kept wet with 82% alcohol. The best way to keep the knife wet is to have a dropping bottle over the object, the drops falling about every two seconds. As the sections are cut they are drawn up towards the back of the section knife with a soft brush. They can be kept in order in this way and not interfere with succeeding sections.

Some operators in drawing the knife across the tissue use a slight sawing motion. However one proceeds, the knife is drawn rather slowly, not rapidly as with paraffin work.

If the imbedding was done in a paper box, remove the box and trim the collodion block suitably. Dry the end away from the tissue, wet it with 3% collodion. Use a piece of wood, a cork, or other holder of suitable size. Put some 6% collodion on the holder and let it dry for a minute or so; then press the collodion block down on the holder. Leave in the air for a minute or two and then put into 67% alcohol

to harden the cementing collodion. After 15 minutes, or longer if convenient, put the mounted specimen into the clamp of the microtome and cut as above.

Sometimes when the imbedded object is of sufficient size and the collodion block is firm, the block itself is put into the microtome clamp, no wood or cork holder being used.

§ 633. **Transferring sections from the knife to the slide.** — When one has cut the number of sections for one slide, they should be transferred to the slide as follows: Take a piece of white tissue paper about 3×6 centimeters in size and lay it on the knife over the sections. Press down slightly so the paper is in contact with all the sections. Take hold of the paper beyond the edge of the knife and gradually pull it down off the knife.

If there is the right amount of alcohol on the knife, the sections adhere to the paper and move with it. This transfers the sections from the knife to a piece of tissue paper. Place the tissue paper with the sections down on the middle of an albumenized slide. Cover with another piece of paper and press down gently. This presses the sections against the slide and absorbs a part of the alcohol. Take hold of one edge of the paper and lift it with a rolling motion from the slide. The sections should stay on the slide (§ 633a).

§ 633a. — Various forms of paper have been used to handle the collodion sections. It should be moderately strong, fine-meshed, not liable to shed lint, and fairly absorbent. One of the first and most successful papers recommended is "closet or toilet paper." Cigarette paper is also excellent. In my own work the heavy white tissue paper has been found almost perfect for the purpose. Ordinary lens paper or thin blotting paper for absorbing the alcohol or oil may be used with it.

§ 634. **Fastening the sections to the slide.** — With a pipette, drop 95% alcohol on the slide of sections, then use a pipette full of absolute alcohol if it is at hand. Drain most of the alcohol away and add a few drops of ether alcohol. The collodion should melt and settle down closely on the slide. If the collodion does not melt the dehydration was not sufficient and more alcohol must be used. After the collodion has melted down upon the slide let the slide remain a minute or two in the air, and then transfer the slide to a jar of 67% alcohol (fig. 232).

After half an hour or longer the preparation is ready to stain.

§ 635. **The castor-xylene method of sectioning.** — The preparation of the tissue is the same as described in § 625-629, except that when the collodion is hardened in chloroform it is transferred, not to alcohol, but the block is placed in castor-xylene (§ 554). In a few days the collodion gets as transparent as glass and one can see the tissue within with great clearness. It can remain in the castor-xylene indefinitely.

In cutting one proceeds exactly as in § 632, except that the block is kept wet with castor-xylene and not with alcohol. The sections are arranged on the knife and transferred to the slide in the same way as for alcohol sectioning (§ 633-634).

For fastening the sections to the slide, as no water is present, one can add the ether alcohol at once. It is advantageous here to have a mixture of ether two parts and absolute alcohol one part for melting the collodion in these oil sections.

Allow the slide to remain in the air till the collodion begins to look dull; then the slide may be transferred to a jar of xylene to remove the oil. From the xylene it is transferred to 95% alcohol and then the slide is ready to be stained, etc., as described below (§ 638).

§ 636. **Steps in order for the collodion method.**—

Name	No.
Animal.....	95% alc.....
Date.....	Ether-alc.....
Fixer.....	1½% col..... 3% col.....
Time of fix.....	6% col..... 8% col.....
Washed in water.....	Imbedded.....
67% alc..... 82% alc.....	Chloroform..... 67% alc.....
Decalc. § 398.....	Or castor-xylene.....
67% alc..... 82% alc.....	Sections cut..... μ's.....
<i>In toto</i> stain.....	Stains.....
Washed in.....	Mounted in.....
67% alc..... 82% alc.....	Remarks.....

DOUBLE IMBEDDING IN COLLODION AND PARAFFIN

§ 637. **Need of double imbedding.** — Some objects like ova with considerable yolk and other objects in which the different parts are of unequal density or very loosely bound together are advantageously

imbedded first in collodion so that there will be a tough matrix to hold the parts in place, and then for ease and rapidity of sectioning paraffin imbedding is added.

Steps in double imbedding:

1. Fix in any desired way.
2. Dehydrate with absolute alcohol half a day or more.
3. Put into ether alcohol half a day or more.
4. Put into $\frac{3}{4}\%$ collodion half a day or more.
5. Put into $2\frac{1}{2}\%$ collodion 1 to 2 days.
6. Put into 5% collodion for one day or longer.
7. Imbed in the 5% collodion, using a paper box (fig. 221). Take the precaution to lightly vaseline the inside of the paper box (§ 631, 657).
8. Float the imbedded tissue on chloroform in a glass dish.
9. When the collodion is hardened by the chloroform, remove the paper box and transfer to the castor-xylene (§ 554) clarifier to finish hardening and clarifying the collodion mass.
10. Put into melted paraffin for infiltration. Leave in the infiltrating oven (fig. 220) a day or two. There is some advantage, according to some, in transferring to pure xylene or to cedar-wood oil for half a day before putting into the imbedding paraffin. Section in ribbons as with paraffin (§ 615).

The sections are spread and stained exactly as for the paraffin method, except that carmine cannot be used without staining the collodion.

STAINING AND PERMANENT MOUNTING

§ 638. **Generalities on stains.** — From the standpoint of the object to be stained, dyes may be divided into two great groups:

(1) (a) Those which select out or differentiate certain parts of the tissue and make them prominent. Such dyes are called then *differential* or *selective*. If the nucleus is the part selected, the dye is frequently called a *nuclear dye*.

(b) *General or counter stains*. These stain all parts of the tissue, and are usually contrasting in color; blue or purple and bright red are frequent combinations, e.g. hematoxylin and eosin. There is an

appearance of differentiation even with a general stain, as the denser portions of the tissue seem more deeply stained; that is, there is more substance and more stain is taken up and hence the color is deeper.

(2) From the standpoint of the solvent used in preparing the stains they are called (a) *aqueous*, and (b) *alcoholic*.

If one uses an aqueous stain the object must be well wet with water before the stain is applied, and afterward well washed with water before put again into alcohol. If an alcoholic stain is used the object to be stained should be from alcohol of the same strength as that used in making the dye. The dye is also washed away from the tissue with the same strength of alcohol; it may then be put into the stronger alcohols for dehydration.

With reference to the now much used anilin dyes, Wright, Principles of Microscopy, p. 34, gives this excellent general statement: "Anilin dyes may be regarded as salts containing a coloring element or chromophor, united to a base or acid, according as the chromophor in question possesses, in the particular case, acid or basic properties. In the case where the chromophor functions as an acid, the dye is denoted an *acid dye* (e.g. eosin). In the case where the chromophor functions as a base, the dye is designated a *basic dye*." Eosin is used as an example where the chromophor functions as an acid and methylene blue where the chromophor functions as a base.

The tissue elements, and their parts are named from their affinity for acid or basic dyes. For example, in the blood, the red corpuscles and the granules of some of the leucocytes have an affinity for acid chromophores and hence stain strongly with eosin. They are accordingly said to be acidophil or oxyphil, sometimes also eosinophil. The nuclei of all the leucocytes, and of the red corpuscles when nucleated, and the granules of some of the leucocytes, have an affinity for basic dyes and hence stain with methylene blue, and are designated basophil.

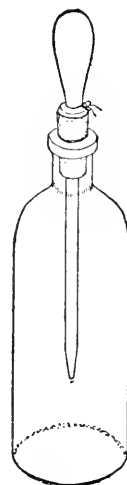

FIG. 234. REAGENT BOTTLE WITH PIPETTE.

§ 639. **Staining with hematoxylin.** — Take a slide of sections prepared by the paraffin or the collodion method from the jar of alcohol and plunge it into a vessel of water to remove the alcohol. For staining put the slide of sections into a jar or shell vial of the hematoxylin solution or one can lay the slide flat on the staining rack or some other support and add the stain to the sections (fig. 235-236). It usually takes from 2 to 10 minutes to stain sufficiently with hematoxylin.



FIG. 235. BOWL WITH DRAINING RACK AND FUNNEL FOR STAINING SECTIONS.

A good plan when one is learning the process is to wash off the stain after one minute, either with a pipette or by putting the slide in a dish of water. Wipe off the bottom of the slide and put it under the microscope. Light well, use a low power, and one can see the nuclei stained a bluish or purple color, as hematoxylin is a nuclear dye. If the color is faint, continue the staining

until the nuclei stand out boldly. Sometimes it takes a long time to stain well with hematoxylin. In such a case the jar of stain may be put into the paraffin oven and the heat will accelerate the staining. One may also heat the individual slides as for spreading sections, but one must be careful not to let the stain dry on the sections. As the stain evaporates add fresh stain with a pipette.

When the sections are well stained with hematoxylin, wash off the hematoxylin with water. If the slide is allowed to stand some time in ordinary water the color is likely to be brighter. This is due to the action of the alkali (ammonia, etc.) usually present in natu-

ral waters. One could use distilled water, adding a few drops of a saturated solution of lithium carbonate.

Dehydrate in 95% alcohol and absolute if necessary; clear and mount in balsam as described in § 513.

Hematoxylin is so nearly a pure nuclear stain for most tissues and organs that the cell bodies are not very evident with this alone; hence some counterstain is generally used also.

§ 640. Counterstaining with eosin. — One of the solutions of eosin (§ 562) is dropped upon the sections after the hematoxylin has been washed away with water. This stains almost instantly. One rarely needs to stain with eosin over 10 or 30 seconds. The excess stain is then washed away with pipette or by dipping the slide into water.

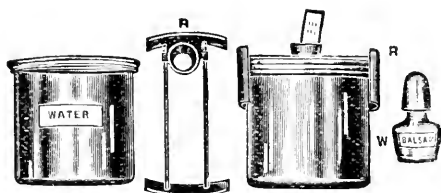

FIG. 236. SMALL AQUARIUM JARS FOR STAINING SERIAL SECTIONS.

R Rack for the top of the jar and containing a small draining funnel.

At the left is a spirit lamp used as a balsam bottle.

§ 641. Dehydrating and clearing. — Put the slide directly into 95% alcohol after it is rinsed with water. Leave it in the alcohol a short time and transfer to fresh 95% alcohol or to absolute alcohol a few seconds, 10–20. One must not leave the sections too long in the alcohol or the eosin will dissolve out.

Remove the slide from the alcohol and put it into a jar of clearer (§ 552) or put it on the rack (fig. 235–236) and add enough clearer to cover the sections. Soon the clearer will displace the alcohol and make the sections translucent. It usually requires only half a minute or so. The clearer is drained off and balsam put on the sections, and then a clean cover-glass is added. One soon learns to use the right amount of balsam. It is better to use too much than too little (§ 513).

§ 641a. — In the past the plan for changing sections from 95% alcohol to water, for example, has been to run them down gradually, using 75, 50 and 35% alcohol, successively. Each percentage may vary, but the principle of a gradual passing from strong alcohol to water was advocated. On the other hand I have found that the safest method is to plunge the slide directly into

water from the 95% alcohol. The diffusion currents are almost or quite avoided in this way. There is no time for the alcohol and water to mix; the alcohol is washed away almost instantly by the flood of water. So in dehydrating after the use of watery stains, the slide is plunged quickly into a jar of 95% alcohol. The diffusion currents are avoided in the same way, for the water is removed by the flood of the alcohol. This plan has been submitted to the severe test of laboratory work, and has proved itself perfectly satisfactory (1895-1908).

§ 642. **Counterstaining with the eosin in the clearer.** — With this method the eosin is dissolved in the carbol-xylene clearer (§ 552a), and the hematoxylin stained sections are dehydrated with 95% alcohol and absolute alcohol if necessary and then placed in the clearer. The sections are cleared and stained in eosin at the same time. It usually takes half a minute or more for the double process. When the sections are clear and sufficiently red, the slide is removed and the clearer drained off by holding in the forceps or in the draining funnel (fig. 235-236). Then the balsam is added, and covered as described above.

It is a good plan to rinse off the stained clearer by pure xylene before adding the balsam. This is not absolutely necessary, however.

§ 643. **Hematoxylin and picro-fuchsin.** — Picro-fuchsin is so selective in its general staining that it is frequently used after hematoxylin. The hematoxylin staining should be intense and after the hematoxylin is washed away add the picro-fuchsin (§ 587). It takes only a few seconds for it to act, 10 to 30 seconds. Wash with distilled water, or natural water very faintly acidulated. The acid fuchsin is very sensitive to alkalis and fades easily.

Dehydrate in 95% and absolute alcohol, clear and mount in acid balsam. Acid balsam injures hematoxylin, but is necessary for the red in the picro-fuchsin.

Look out for mercuric chlorid crystals in the sections (§ 654).

§ 644. **Hematoxylin and mucicarmine.** — Tissues and organs are best fixed in Zenker's or mercuric chlorid. Small intestine is one of the most striking and instructive organs for this double stain. Make the sections by the paraffin method, but do not fasten them to the slide with collodion, for collodion stains with mucicarmine (§ 549).

Stain 1 to 24 hours in mucicarmine. Wash off the stain with water

and then stain with hematoxylin. Do not stain too deeply. Wash with water, dehydrate, clear and mount in natural balsam. Nuclei will be bluish or purple and the cells containing mucus will be rose red. The goblet cells of the villi stand out like small red goblets, and if any mucus is streaming out of them it will be red.

§ 645. **Elastic tissue stain.** — Take a slide of sections made either by the paraffin or the collodion method from alcohol and put the slide into a jar or a shellvial of the stain. This is an alcoholic stain, hence the sections should not be washed in water. Allow the stain to act from a half hour to an hour. Wash off the superfluous stain with 95% alcohol from a pipette or by rinsing in a jar of 95% alcohol. It is better in either case to use the pipette and clean alcohol for the final washing.

This stain alone gives a bluish tone to the entire tissue, the elastic tissue being stained a very deep blue. For greater contrast and to bring out the white fibrous tissue, muscle, etc., counterstain with picro-fuchsin of one-fourth the strength given in the regular stain (i.e., picro-fuchsin 1 part, distilled water 3 parts).

Dip the slide of sections into distilled water, and then into a shellvial of the stain. Stain 15 to 30 seconds on the average. Wash in distilled water and dehydrate in 95% alcohol and absolute if necessary, then clear in carbol-xylene and mount in acid balsam (§ 547). The elastic tissue should be almost black; white fibrous tissue, red; muscle, blood, and epithelia yellow or yellowish. Arteries are excellent for this combination.

§ 646. **Combined elastic mucicarmine and picro-fuchsin stain.** — For this, one should take some object that is known to contain elastic tissue, mucus, white fibrous tissue, and muscle. (The non-cartilaginous part of the trachea is excellent). The organ should have been fixed in mercuric chlorid or Zenker's fluid (§ 579, 592), for this preparation. The sections should be made by the paraffin method and no collodion should be used for fastening the sections to the slide (§ 622), for collodion is stained by mucicarmine.

(1) Stain first in the elastic stain 1 hour. Wash well with 95% alcohol and then with water.

(2) Stain in a shellvial or jar of mucicarmine (§ 549) from 1 to 24

hours. Wash well with water, but one must be careful in treating these sections, as they have no collodion mantle to protect them.

(3) Stain 15 to 30 seconds with picro-fuchsin of one-fourth strength (§ 645). Dehydrate with 95% and if necessary absolute alcohol. Clear in carbol-xylene and mount in acid balsam (§ 547). The elastic tissue will be black or blue black. Mucus will be carmine or rose red; white fibrous tissue will be magenta red; muscle, epithelium, and blood will be yellow.

§ 647. **Eosin methylene blue.** — One of the best objects for this stain is a hemolymph gland. Such a gland is easily and surely found by a beginner if he takes the heart and lungs of a veal. In the fat around the heart and behind the pleura will be found red bodies looking almost like blood clots. Remove carefully; fix in Zenker's fluid or mercuric chlorid (§ 579, 592). Section by the paraffin method, make the sections 5μ and 10μ thick. Use collodion for insuring the fixation to the slide (§ 622). Stain the sections 5 minutes in alcoholic eosin (§ 563). Wash off the eosin stain with water. (This is an exception to the generalization in § 638.)

Stain in methylene blue (§ 580) one-half to 5 minutes. Rinse well in tap water. Dehydrate with neutral 95% alcohol and with absolute alcohol. Work rapidly with only one slide at once. Clear with pure xylene, mount in neutral balsam (§ 546). All nuclei should be blue, and all red blood corpuscles bright eosin red. If one is successful this is a most striking and instructive preparation. Spleen is also very instructive.

Eosin-methylene blue staining is also excellent for demonstrating mucus.

Do not forget that mercury is liable to be present in sections of tissue fixed with any mercuric fixer. Remove it with iodized alcohol (§ 576). This should be done before the staining. One can tell whether the tissues contain mercury by looking at the unstained sections. The mercury looks black by transmitted light, white by reflected light. Seen by transmitted light, the substance is often in the form of delicate black pins.

§ 648. **Iodin stain for glycogen.** — Use tissue fixed in 95% or absolute alcohol. Cut by the paraffin method. Mount the sections in

serial order. Do not use water for spreading the sections, but one of the iodine stains for glycogen (§ 575). The glycogen will be stained at the same time that the sections are spread.

Let the sections dry thoroughly after spreading. Deparaffin with xylene and mount in yellow vaseline or use thin xylene balsam, but do not put a cover-glass over the balsam preparations.

The iodine stain remains in the spread sections for ten years or longer. One can restrain any time by putting the slide with the spread, but not deparaffined sections, in a shellvial of the iodine stain. It is possible also to stain the nuclei with hematoxylin in the same way. If this is done the hematoxylin should be used first and washed off with water and the iodine stain be used last, but not washed off with water.

ADVANTAGES OF HISTOLOGICAL SERIAL SECTIONS

§ 649. **General on series.** — It is coming to be appreciated more and more that in histology as well as in embryology one can only get a complete knowledge of structure by having the entire organ cut in microscopic sections and each section mounted in order. Furthermore, it is necessary to have the organ cut in three different planes. In this way one can see every aspect of the structural elements and their arrangement in the organs.

In single sections one gets only a partial view. For example, how many students have any other idea of a ciliated cell than that it is a cell with triangular outline with a brush of cilia at the broad end. Probably many would be puzzled if they had a top view of the ciliated end; and the attached end would be even more puzzling.

It may not be possible for every worker to make serial sections of all the organs in all the three planes, but every one who is working seriously in histology can make all his preparations serial; that is, the sections which are mounted can be in serial order; then a puzzling appearance in one section may be perfectly intelligible in one a little farther along.

To get the greatest benefit from serial as indeed also from single sections, the sections should be made in a definite manner; that is, they should be exactly across the long axis of an organ or parallel with the long axis (*Transsections* and *Longisections*).

Or with such an organ as the liver, the skin, etc., the sections may be parallel with the surface (*Surface Sections*) or at right angles to the surface (*Vertical Sections*).

§ 650. **Order of serial sections.** — Some plan must be adopted in arranging the series or only confusion will result. An excellent plan is to arrange the short pieces of ribbons for a given slide as the words on a page are arranged. That is, section No. 1 is at the upper left-hand corner. The next row of sections begins where the first row left off, etc. (fig. 237).

As the paraffin stretches considerably one must cut the ribbons into pieces considerably shorter than the cover-glass to be used.

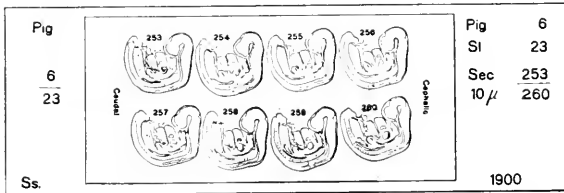

FIG. 237. A SLIDE OF SERIAL SECTIONS SHOWING THE ARRANGEMENT AND ORDER OF THE SECTIONS; ALSO THE LABELING OF THE SLIDE.

Both the paraffin and collodion methods are adapted to the preparation of series. The paraffin ribbons are easier to manage and easier to make than the serial sections in collodion.

By arranging the collodion sections as they are cut on the knife in collodion sectioning (§ 632), one can put them on the slide in perfect series by the tissue paper method (§ 633).

If the sections are large, as in cutting serial sections of the central nervous system, the series can be kept in order in a small dish by putting a piece of tissue paper over each section and piling them up. If the vessel is small enough the papers and sections will not shift and get out of order. Or one might put a single section in a Syracuse watch glass or a Petri dish. Then in mounting the sections can be taken in order.

§ 651. **Numbering the serial slides.** — For temporary numbering a fine pen with Higgins' or Weber's waterproof carbon ink serves

well. If the end of the slide is varnished, one can write on it as well as on paper. When the ink is dry it should be coated with thin xylene balsam or with any good varnish like valspar 1 part, xylene 9 parts. It is also important to write the number of the slide with a writing diamond. The double marking is desirable because with wet slides the diamond number is hard to see, while the ink marks are clearly visible. One is not so liable to wipe off the sections if the ink mark is present.

FIXING AND STAINING FOR SERIES

§ 652. **Fixing.** — The two most used fixers for embryos are Zenker's fluid and formaldehyde (§ 568, 592). For those unskilled in microscopic technic, or for one who is exceedingly busy, the best results are obtained by putting the embryos in formaldehyde (10 parts of formalin, the formalin of the pharmacy, and 90 parts water answers well). If there is plenty of this the embryos are likely to be well preserved even though they are left in the membranes, and that is far the best way for small embryos.

§ 653. **Fastening the sections to the slide.** — For all serial work it is especially desirable to fasten the sections to the slide with collodion (§ 622). This should always be done unless some stain like carmine is to be used on the slide after the sections are fastened. With thin sections, if one is careful enough, an entire series can be carried through without losing a section, but with thick sections (15μ and thicker) some are almost sure to separate from the slide if not fastened by collodion.

§ 654. **Removal of mercuric chlorid from sections.** — It should be remembered that if a fixer containing mercuric chlorid is used the sections are almost sure to contain mercury. By transmitted light the mercury appears dark. Often the appearance is as if a multitude of delicate black pins were in the section. Sometimes the mercury is in rounded masses. This should be removed by putting the slides of sections into alcoholic iodine (§ 576). After half an hour or an hour wash off the iodized alcohol with pure 95% alcohol and the sections are ready for staining.

If the embryo was stained *in toto* and contains mercury, the sec-

tions should be passed from the deparaffining xylene to the iodized alcohol (§ 576). After half an hour or more the slides are passed through pure 95% alcohol, and back to the xylene or to carbol-xylene. Then they can be mounted in balsam.

§ 655. **Staining for series.** — There is a great advantage in point of time and safety in staining the entire embryo in some good stain like borax carmine (§ 548). Carmine is a very permanent stain also. For bringing out special structural details the sections are stained on the slide as described in § 639-640. The slide baskets are almost a necessity for serial work (fig. 231-232), as the slides are handled individually only twice, (1) when they are spread and dried and put into the baskets, and (2) after all the processes are complete and the sections are to be mounted in balsam.

The sections are mounted in balsam directly from the deparaffining xylene. No alcohol is used unless it is necessary to remove crystals of mercuric chlorid (§ 576, 654).

COMPLETE SERIES OF EMBRYOS AND SMALL ANIMALS IN THE THREE
CARDINAL PLANES, — TRANSECTIONS; SAGITTAL SECTIONS;
FRONTAL SECTIONS

§ 656. **Serial sections of entire animals.** — With improvement in means for making thin sections of objects, the long desired ability to see the entire organism in complete series is now easily realized. What was formerly determined with so much difficulty in dissecting embryos can now be attained with ease in a complete series. It is almost too easy, and with a lively imagination structural arrangements are described and depicted which never actually existed in the animals or embryos themselves. It is so difficult for most people to add the third dimension accurately when working with flat specimens that it is now appreciated that the older workers had a great advantage in dissecting the entire animal or embryo because they were there dealing with an obviously three-dimensional object and true relations in space were seen. There is now a wholesome tendency toward the retention of the advantages of dissection of entire forms with the advantages of serial sections. Hence embryos are now dissected entire almost as much as in the old days, and enlarged models of the

series are made so that the object can be seen in three dimensions, the models also serving to make it easy to follow out the relations of parts with the naked eye. But one should not forget that a model, like a drawing, is after all only the interpretation of the artist and the thing itself must be referred to whenever there is to be real advancement in knowledge. Furthermore, as it is not possible to both dissect and serial section the same object, and sometimes very few are available, anatomists have decided on the three planes which give the greatest information, — transections or cross sections, sagittal sections, and frontal sections. With sections in these three spatial planes it is possible to gain some just conception of the actual relation of parts and structures in the object.

§ 657. **Orientation of imbedded objects.** — In order that sections may be made in any desired plane the object must be so arranged or *oriented* in the imbedding mass that one can attach the imbedding block to the microtome holder, and then arrange for sectioning in a definite manner. With translucent or transparent collodion where the position of the object can be seen after it is imbedded, this is not particularly difficult, but with paraffin, which is nearly opaque, one cannot see distinctly enough the position of the object to give the exact arrangement necessary to make precise sectioning possible. The embryo or animal or other object must therefore be arranged in the imbedding box in a very definite manner.

To overcome the difficulties Dr. Kingsbury, ten to fifteen years ago, devised the method of making a diagram of the object to show its exact shape and position. (*Anat. Record*, Vol. XI, 1916, p. 294). The method is as follows: A natural-size diagram of the object is made on the inside of the bottom of the imbedding box before any paraffin is put into it. This is most easily done before the box is folded, or the folded box can be unfolded and made flat again. For making the diagram a soft lead pencil can be used or one of the ordinary colored crayons or a colored glass pencil. In any case enough of the lead pencil or the crayon mark adheres to the paraffin to make a clear diagram on it of the object.

In imbedding, the object should be arranged exactly over the diagram. The solidified layer of paraffin formed before the object is

placed in the box (§ 612) is no hindrance, as the diagram shows through it clearly.

For embryos and small animals, of which serial sections are to be made, there should always be a photograph natural size.

The diagram for orientation is easily made from such a photograph by the use of the drawing shelf (fig. 247, A.D.S., § 289, 291). As the embryo or animal is always imbedded with the right side down, left side up, one must be sure to have the diagram in the same position. This is easily accomplished, as one can draw equally well with the photographic print whichever side is up. That is, if the embryo was photographed left side down, the print should be face down on the drawing shelf to bring the diagram in the imbedding box with the left side up. On the other hand, if the photograph was made with the embryo right side down, then the print should be face up when making the diagram on the bottom of the imbedding box.

With the definite outline of the embryo or animal on the bottom of the imbedding mass one has a good guide for arranging the object for sectioning any desired plane.

§ 658. **Thickness of serial sections.** — The thickness of the sections of a series should be known in all cases; and for modeling it is absolutely necessary (§ 665, 669). The thickness usually depends somewhat upon the size of the object to be made into series. If the object is small the sections can be thin without having an unmanageable number of slides. With larger objects the sections are naturally made thicker to keep the length of the series within bounds.

One of the following thicknesses will be found to meet nearly all requirements and make modeling easier than as if some odd number of microns were used: 5μ , 10μ , 15μ , 20μ , 25μ , 30μ , 40μ , 50μ , 75μ , 100μ . Of course every investigator decides for himself the thickness of section which will serve his purposes best.

§ 659. **Arrangement of sections on the slide.** — (1) A satisfactory and widely adopted method is to arrange the the sections like the printed words in a book. This brings the first section at the upper left-hand corner of the series, and the last section at the lower right-hand corner (fig. 239).

(2) It is a great advantage to have the sections so arranged on

the slide that under the compound microscope the aspects will be as in the observer's body; then it will be easy to locate objects at the right or left, dorsal or ventral.

(3) Remember that in the ribbons the surfaces are somewhat unlike in appearance. The lower surface, that is the surface facing the section knife, is shiny, while the opposite surface is dull. This knowledge is important, for sometimes sections get turned over accidentally. It is unfortunate to have part of the sections of a series wrong side up.

(4) The aspect cut first will face upward on the slide, that is, if the head is cut first the cephalic aspect will face up; if the left side is cut first the sinistral aspect will face up, and if the dorsal side, the dorsal face will be up.

(5) The aspect of the embryo which first meets the edge of the knife will be at the beginning of the series. If arranged and cut as here directed, transections would have the right side of each section toward the left on the slide (fig. 239). Under the compound microscope it would appear on the right.

For sagittal sections where the caudal end meets the knife, the caudal end of the section would be toward the left on the slide (fig. 242).

For frontal sections (fig. 240) where the right side meets the knife edge first, the right side of each section will be toward the left end of the slide.

§ 660. **Mounting.** — Cut the ribbons into segments of equal length, using preferably a curved knife (fig. 223). Transfer to albumenized slides with fine forceps (fig. 225). Make parallel with the long axis of the slide, and put the first section at the upper left-hand corner (fig. 237).

In a word, decide on some good plan for mounting series and follow the plan consistently.

§ 661. **Size of slides and cover-glasses for series.** — (1) If the object is small, the standard slide 25×75 mm. (fig. 185) is good and the cover-glass can be either 22 or 23 mm. wide and 50 or 60 mm. long. The smaller sizes are to be preferred when convenient, for more space is left to the label, and the cover-glass is not too near the edge as with wide covers.

(2) If the embryo or animal is of moderate size, that is, not over 30 to 35 mm. long, one can use advantageously the intermediate size of slides (fig. 186), that is, those 38×75 mm. A suitable cover-glass is 35×50 or 35×60 mm.

(3) For objects of considerable size, i.e., over 35 mm. in length, if sagittal or frontal sections are to be made, and if they are to be mounted crosswise, the slide must be of sufficient width. Ordinarily the large standard, 50×75 mm., will answer (fig. 187). For the large slides the covers can be 48×60 or 48×65 mm. For special large sizes of object, special slides can be made of lantern slide covers or old negative glass, etc., and for cover-glasses one can go back to the earlier workers and use mica.

Do not use too thick cover-glasses or high powers cannot be employed in studying the sections (§ 76-81).

TRANSECTIONS OR CROSS SECTIONS

§ 662. **Transections** are those made by dividing the body into sections made across the long axis of the body. This divides the embryo

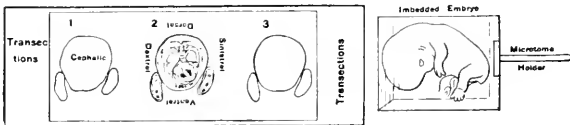

FIG. 238. SERIAL TRANSECTIONS.

At the left is the embryo in the imbedding mass and attached to the microtome holder.

At the right is a glass slide showing how the sections are to be mounted.

Imbedded embryo—It is in the proper position for transections.

In section 1, the word cephalic shows that the section is cephalic face up; the caudal face rests on the slide. In the middle section the words indicate the edges of the section. Under the microscope the words will be erect. Invert the book and the appearance will be the same as under the microscope.

or animal into equal or unequal cephalic and caudal segments. With microscopic sections of course the segments of the entire body are very unequal, although each section may be of equal thickness.

(1) Imbed the embryo or animal with the right side down, taking the precaution to have a layer of partly solidified paraffin at the

bottom of the box (§ 612); and arrange the object exactly over the orientation diagram in the bottom of the imbedding box (§ 657).

(2) Mount the block of paraffin containing the embryo so that the caudal end is next the microtome holder. The head is then cut first, and the caudal surface of the sections will rest upon the slide, bringing the cephalic face up (fig. 238).

(3) Place in the microtome so that the right side of the embryo or animal meets the edge of the knife.

(4) Mount the sections like the words in a printed line. This will bring the first or most cephalic section at the upper left-hand corner.

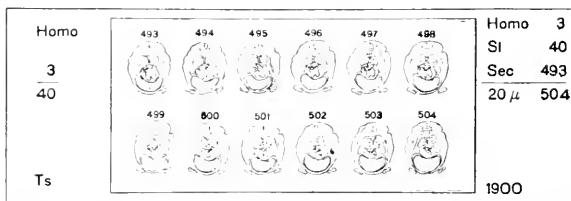

FIG. 239. A SLIDE OF SERIAL TRANSECTIONS SHOWING THE ARRANGEMENT AND THE LABELING OF THE SLIDE.

The cephalic face will be up, and the dorsal aspect next the upper edge of the slide.

Under the compound microscope the rights and lefts will appear as in the observer's own body, as will also the dorsal and ventral parts.

FRONTAL SECTIONS

§ 663. **Frontal sections.** — These are sections made by dividing the body into equal or unequal dorsal and ventral parts.

(1) Imbed the animal or embryo with the right side down in the imbedding mass (§ 612); and arrange the object exactly over the orientation diagram in the bottom of the imbedding box (§ 657).

(2) Mount the block of paraffin containing the embryo so that the ventral aspect of the embryo or animal is next the disc of the microtome holder (fig. 240). The dorsal part is then cut first, and the ventral surface of the sections will rest upon the slide, bringing the dorsal face up.

(3) Place in the microtome so that the right side of the object meets the edge of the knife first.

(4) Mount the sections like the words in a printed book. This will bring the first or dorsalmost section in the upper left-hand corner

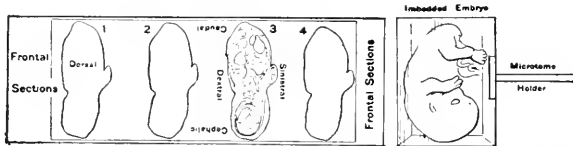

FIG. 240. FRONTAL SERIAL SECTIONS SHOWING THE ARRANGEMENT OF THE EMBRYO IN THE IMBEDDING MASS, THE CONNECTION WITH THE MICROTOME HOLDER, AND THE POSITION OF THE SECTIONS ON THE GLASS SLIDE.

Microtome Holder The metal disc and stem for holding the imbedded embryo in the microtome while sectioning.

Imbedded Embryo The embryo in the proper position for frontal sections.

Frontal Sections A slide showing the proper arrangement of frontal sections.

1, 2, 3, 4 Serial order in which the sections are arranged like the words in a printed book.

In section 1 the word dorsal indicates that the section has its dorsal face upward away from the slide while the ventral face is down in contact with the slide.

In section 3, the words cephalic, caudal, dextral, sinistral are wrong side up so that they will appear erect under the compound microscope.

of the series. The dorsal face will be up, the right side to the left, and the cephalic end toward the lower edge of the slide (fig. 240-241).

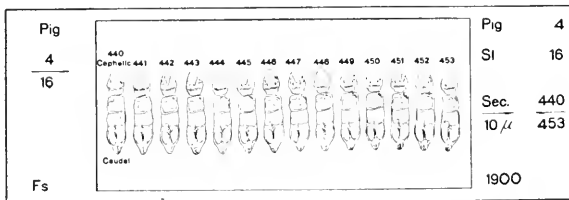

FIG. 241. FRONTAL SERIAL SECTIONS SHOWING THE ARRANGEMENT AND THE NUMBERS OF THE SECTIONS ON THIS SLIDE. THE SLIDE IS PROPERLY LABELED.

Under the compound microscope the cephalic end will be away from the observer or in front, and the rights and lefts will be as in his own body.

If the sections are too long to mount crosswise they can be cut apart and mounted lengthwise of the slide, the order being like that of the words in a line of print as with all serial sections.

SAGITTAL SECTIONS

§ 664. **Sagittal sections** are those made parallel with the long axis of the body and from the dorsal to the ventral surface, thus dividing the object into equal or unequal right and left (dextral and sinistral) parts.

(1) Imbed the animal or embryo with the right side down in the imbedding mass (§ 612); and arrange the object exactly over the orientation diagram in the bottom of the imbedding box (§ 657).

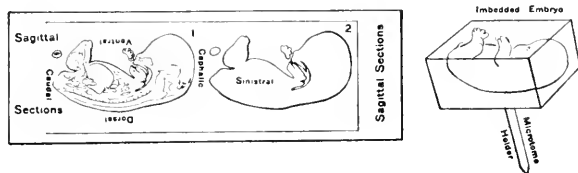

FIG. 242. SERIAL SAGITTAL SECTIONS SHOWING THE POSITION OF THE EMBRYO IN THE IMBEDDING MASS, THE CONNECTION WITH THE MICROTOME HOLDER AND THE ARRANGEMENT OF THE SECTIONS ON THE GLASS SLIDE.

Microtome Holder The metal disc and stem for holding the embryo in position while it is being cut.

Imbedded Embryo The imbedded embryo in the proper position for sagittal Sections.

Sagittal Sections A slide of sagittal sections in the proper position on the slide.

1, 2 Serial order in which serial sections are arranged on the slide.

In section 2, the word sinistral indicates that the left surface of the section faces directly upward. The right side rests upon the glass.

The words cephalic, caudal, dextral and sinistral are inverted under the compound microscope, the sections are reinverted, and will appear like this picture, if the book is turned upside down.

(2) Mount the block of paraffin containing the embryo so that the right side will be next the disc of the microtome holder. The left side will then be cut first, and look up when mounted (fig. 242).

(3) Place in the microtome so that the caudal end will first meet the edge of the knife.

(4) Mount the sections in the order of the print on a page. This will bring the caudal end to the left, the cephalic at the right, ventral aspect up and dorsal down toward the lower edge of the slide. The dextral face of the section will rest on the slide, and the sinistral face will look up.

Under the microscope the head will be at the left and the dorsal side will appear toward the upper edge of the slide — away from the observer. It will appear like the figure when the the book is turned upside down.

If the embryo is large it may be better to turn it around so that the ventral side meets the edge of the section knife. If this is done the sections will have to be cut apart and mounted one by one on the

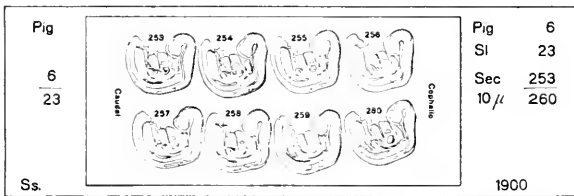

FIG. 243. SLIDE OF SERIAL SAGITTAL SECTIONS SHOWING THE ARRANGEMENT AND LABELING.

slide, otherwise they would be crosswise of the slide like the frontal sections (fig. 240).

§ 665. **Labeling serial sections.** — The label of a slide on which serial sections are mounted should contain at least the following:

The name of the embryo and the number of the series; the number of the slide of that series; the thickness of the sections, and the number of the first and last section on the slide; the date. It is also a convenience to have the information repeated in part on the left end (fig. 237–243).

MODELS FROM SERIAL SECTIONS

§ 666. **General considerations on modeling.** — Anatomists have for a long time produced models of gross anatomic specimens, and enlarged models for minute details.

Naturally, after serial sections of embryos and organs came to be made with considerable accuracy and of known thickness, there was a desire to make enlarged models which should be exact representations of the original rather than the generalized approximations built up as an artist produces a statue.

Further, the difficulty of getting a true conception of the object by studying only two dimensions in the sections is very great; hence a model giving all three dimensions becomes almost a necessity for the beginner in embryology, and is of enormous advantage to an investigator in working out the true form and relation of complex structures. For modeling a series it is of great advantage to have

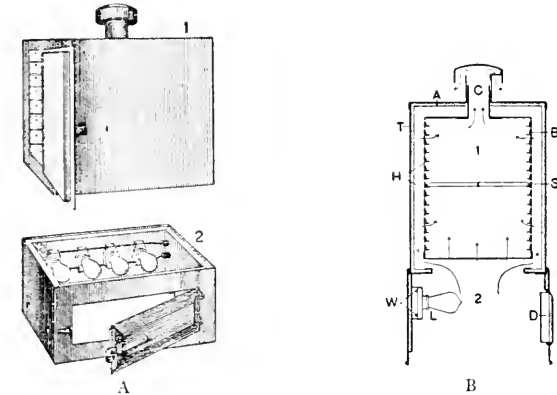

FIG. 244. DRYING OVEN FOR SLIDE TRAYS.

(From the Anatomical Record).

A The oven showing all the parts, the oven proper (*1*) is lifted up to show the electric lamps in the base (*2*).

B Sectional view of the oven (*1*) and base (*2*) showing the construction and the air currents. One tray (*S*) is in position.

A The asbestos lining of the outer shell. *B* One of the numerous ventilating holes. *C* Flue for the escape of air. *H* Runs for the slide trays.

D Door of the support or base (*2*). *W-L* Wiring for the lamps. One can vary the heat by turning out one or more of the incandescent bulbs.

photographs of the object to be modeled. If possible the object should be photographed in the fresh state and after fixation. The more aspects photographed the better.

The principles involved in the construction of a model are exceedingly simple: —

1. It is necessary that the embryo or other object to be modeled should be cut into a series of sections of definite thickness.

2. The sheets of modeling material must be as much thicker than the sections as the model is to be larger than the original.

3. The sections must be drawn as much larger than the actual specimen as the model is to be larger than the object.

4. The drawings with the desired outlines must be made directly upon or transferred to the sheets of modeling material which are then cut out, following the lines of the drawing.

5. The different plates of modeling material representing all the sections are then piled up, in order, thus giving an enlarged model of the object with all its parts in proper position and in true proportions.

MODELS OF WAX

§ 667. **Wax models.** — For making wax models, beeswax 820 grams, paraffin 270 grams, and resin 25 grams are melted together and thoroughly mixed.

To get the sheets of wax of the proper thickness two methods are available: —

(1) The hot wax is poured into a vessel containing hot water. The wax spreads out into an even layer over the hot water and is allowed to cool. While it is solidifying it should be cut free from the edges of the vessel. Of course by calculation and experiment one can put in the right amount of wax to get a plate of a given thickness.

(2) One must have a wax-plate machine consisting of a flat surface — planed cast iron is good — with some means of obtaining raised edges. If these are adjustable by a micrometer screw it is simple to set them properly for the desired thickness of plate. Then there must be a hot roller. The hot wax is poured on the plate, and with the hot roller resting on the raised edges the wax is rolled out into a plate. It cools quickly and may be removed for another plate. This is the most rapid and satisfactory method of preparing the plates. By using a brush with turpentine the paper with the drawing can be wet and then with the hot roller cemented to the plate before that has been removed from the machine.

The wax plate is cut with a sharp instrument, following the outlines of the object which has been traced upon it by the aid of a camera lucida or the projection microscope. The sections are piled together, some line or lines obtained from a drawing or photograph of the

specimen before it was imbedded and sectioned being used as a guide by which the correct form of the pile of sections can be tested. Finally the whole is welded into one by the use of hot wax or a hot instrument. Models which illustrate complex internal structures are difficult to prepare, but numerous devices will occur to the worker, as the representation of blood vessels and nerves by strings or wires. A large model will need much support which can be given by wire gauze, wires, pins, or paper, according to the special needs.

A practical method for wax modeling was first published by G. Born, Arch. f. Mikr. Anat., Bd. xxii, 1883, p. 584. The most detailed statements of improvements of the method have been published by Born (Böhn u. Oppel), 1904, and by Dr. F. P. Mall and his assistants. See contributions to the Science of Medicine, pp. 926-1045. Proceedings of the Amer. Assoc. Anatomists, 1901, 14th session (1900), p. 193. A. G. Pohlman, Zeit. wiss. Mikroskopie, Bd. xxiii, 1906, p. 41.

To overcome the difficulty of cutting out the wax plates, Dr. E. L. Mark of Harvard University uses an electrically heated wire moved rapidly by a modified sewing machine (Amer. Acad. Arts and Sciences, March, 1907; Science, vol. xxv, 1907; Anat. Record, April, 1907).

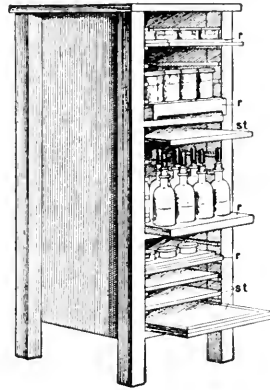

FIG. 245. KINGSBURY'S MOVABLE STAND FOR SLIDE TRAYS AND REAGENTS.

(From the Anatomical Record).

r, r, r Reagent boards with bottles and jars.

st, st Slide trays.

The stand has furniture slides on the legs and is easily moved on the floor.

SUSANNA PHELPS GAGE BLOTTING-PAPER MODELS

§ 668. **Comparison of wax and paper models.** — Wax has certain inherent defects for models: It is expensive, heavy, and fragile. It is easily deformed by the temperature of summer, and the amount of time necessary for the preparation of the plates is great. A wax-plate machine is expensive and bulky.

It therefore seemed worth while to see if there was not some other

material obtainable in the open market which would be more suitable and more generally available.

Blotting paper seemed promising, and an actual trial showed it to be admirably adapted for the purpose. Since making the first model in 1905 it has been constantly used in the laboratory of embryology in Cornell University. Models made from it were demonstrated before the Association of American Anatomists in 1905 and before the International Congress of Zoology in 1907.

“The advantages of blotting-paper models are the ease and cleanliness of their production and the lightness and durability of the product. The models are broken with difficulty, are easily packed or transported, and when they cleave apart are easily repaired, thus contrasting with the weight and fragility of wax models and their deformation by heat.”

“By this process are secured for the original model reconstructed from microscopic sections the same qualities which have made the Auzoux models molded from papier-maché such useful and lasting additions to laboratory equipment; and, in the hands of Dr. Dwight and Mr. Emerton, of Harvard University, have aided so much in the demonstration of structure and form of special anatomic preparations.”

§ 669. **Thickness of blotting paper.** — Blotting paper of a uniform thickness of 1 mm., $\frac{9}{16}$ mm., and $\frac{1}{2}$ mm. was found in the market. The 1 mm. is known as 140 lb. A. and costs about two cents for a sheet 61×48 centimeters (24×19 in.).

The thickness is easily tested by cutting out 50 small pieces, piling them, dipping one end in melted paraffin, and pressing them together. The whole pile should of course measure 50 mm. if the paper is millimeter paper (§ 669a).

§ 669a. — Book-stores, paper dealers and job printers are supplied by the paper manufacturers with samples of blotting paper. One can look these samples over, select and order the kinds desired. The millimeter blotting paper mentioned in the text is one of the cheaper grades, costing by the package of 500 sheets about two cents a sheet (sheets 61×48 centimeters, 24×19 inches).

§ 670. **Size of the model.** — In deciding upon the size of the model to be made from a given series of sections one should select the largest

section and with the projection microscope throw the image on the table (fig. 246). By using different objectives and different distances from the microscope one can find a size which seems suitable. The magnification may be found by § 276. Then by multiplying the whole number of sections by the thickness of the sections and this by the magnification, one can get the length or height of the model. One must take these preliminary steps and decide upon the magnification to be used or the model is liable to be too large to be manageable or too small to show well the necessary detail.

(1) Suppose the model is to be 100 times the size of the original object, and the object has been cut into a series of sections 10μ thick. Then each section must be represented by a plate or sheet 100 times as long, broad, and thick as the object. As the sheets of blotting paper are so large (61×48 cm.), one need be solicitous only about the thickness.

As each section is actually 10μ thick and the model is to be 100 times enlarged, the thickness representing each section must be $10\mu \times 100 = 1000\mu$ or 1 millimeter. 1 millimeter blotting paper is used and every section of the series is drawn.

(2) If the blotting paper were only $\frac{9}{10}$ mm. thick it would be simpler to make the model 90 times the size of the original. If, however, one wished the magnification to be 100, it could be accomplished thus: Each section in the series should be represented by 1 mm. or 1000μ in thickness. But if one uses blotting paper of $\frac{9}{10}$ mm. thickness or 900μ , there is a loss of 100μ for each section and for 9 sections there would be a loss of 900μ or the thickness of a sheet of the blotting paper. To remedy this one uses 10 sheets of blotting paper for 9 sections. This keeps the model in true proportion. In practice each of the sections is drawn upon one sheet except one of them and for that two sheets of the blotting paper are united and the sections drawn upon the double sheet.

§ 671. **General rule for the use of blotting paper.** — Divide the thickness by which each section is to be represented in the model by the thickness of one sheet of the blotting paper available. The quotient shows the number of sheets or the fraction of a sheet required for each section.

If a quotient is a mixed number reduce it to a fraction. The numerator represents the number of sheets required and the denominator the number of sections to go with the sheets.

Examples: (a) With a series of 10μ sections to be modeled at 100 enlargement each section of the series must be represented in the model by a thickness of $10\mu \times 100 = 1000\mu$ or 1 millimeter. If one uses millimeter or 1000μ paper, then $1000\mu \div 1000\mu = \frac{1}{1}$, and one must use 1 sheet for 1 section.

(b) With a series of 10μ sections to be made into a model 100 times enlarged, and with blotting paper of $\frac{9}{10}$ mm. or 900μ thickness, each section must be represented by $10\mu \times 100 = 1000\mu$. If the blotting paper is 900μ thick, then it requires for each section: $1000 \div 900 = 1\frac{1}{9}$ sheets of paper or $\frac{10}{9}$ sheets for one section or 10 sheets for 9 sections, that is a double sheet for one of the nine sections.

(c) With a series cut 15μ , for a 50 fold model, each section is represented by a thickness of $15\mu \times 50 = 750\mu$. If one uses 1 mm. or 1000μ blotting paper, then each section requires $750 \div 1000\mu = \frac{3}{4}$ of a sheet for one or 3 sheets for four sections. In this case one omits every fourth section in drawing, thus: 1st, 2d, and 3d sections would be drawn; then the 5th, 6th and 7th; 9th, 10th, 11th, etc., every fourth being omitted.

(d) If for the model just considered one had $\frac{9}{10}$ mm. or 900μ paper then $750 \div 900 = \frac{5}{6}$. That is there must be 5 sheets of the paper for each 6 sections. In that case every sixth section would be omitted in the drawing, as every fourth section was omitted in (c).

It is of course best to use sheets of exactly the right thickness to represent the necessary thickness in the model (a), but one can produce models with accuracy by duplicating one or more sheets for a group of sections (b) or by omitting certain sections of the series in drawing (c, d).

DRAWINGS FOR MODELS

§ 672. — The methods given for drawing microscopic preparations in Ch. VI are all applicable except the freehand method. This is not applicable, because it is not possible to draw at a uniform and accurate enlargement in that way. But the camera lucida method (§ 275)

or the projection apparatus method (§ 293) is good. With the perfecting of projection apparatus that method is far the best because one can sit in a comfortable position and use both eyes. It is indeed as simple as tracing the outline of actual pictures.

By making negative prints directly on one of the developing papers (§ 363), drawing for models may be wholly avoided.

§ 673. **Avoidance of distortion and of inversion.** — In the drawings for models one must of course avoid all distortion (§269) and the inversion of the image (§ 277). Both these defects are easily avoided if one keeps in mind the optical principles involved, and follows the directions given in Ch. VI.

§ 674. **Use of the 6-volt, concentrated filament lamp as a source of light.** — From the experience of the author nothing equals the direct-current arc light for all exacting work in drawing and projection, and for the dark-ground illuminator, but the care required to keep the arc lamp going and to keep the crater centered is so great that the less brilliant light from the 6-volt lamp which requires absolutely no adjustment after being once properly arranged is very acceptable (§ 362). The 6-volt lamp with a transformer is used only on an alternating circuit. As most lighting circuits are now alternating it is a great advantage; and as this lamp with its transformer can be used anywhere wherever there is an ordinary electric light socket, it is exceedingly convenient. If it is to be used on a direct current circuit no transformer is used, but the current must be drawn from a storage battery, not from a 110 or a 220 volt circuit from a dynamo.

§ 675. **Connections of the transformer.** — If alternating current and a transformer are used, the transformer must be connected to the supply by means of the small connecting wires. The connection with the lamp is by the large terminal wires. Ordinarily the terminals of the transformer are marked so that no mistake need be made. Theoretically the transformer does not modify the energy; it either raises or lowers the voltage or pressure. For the purposes here used the transformer lowers the voltage, and is called a "step down transformer." As the activity or wattage of which the current is capable is not changed by the transformer, and as the wattage is the voltage

multiplied by the amperage used, if the voltage is lowered the amperage is raised proportionally; hence the need of the large wire on the side toward the lamp beyond the transformer where the amperage is increased.

§ 676. **Lamp for 6-volt current.** — There are in common use two lamps, one of 72 watts and one of 108 watts. Now as the wattage is the voltage times the amperage, for the 72-watt lamp the amperage

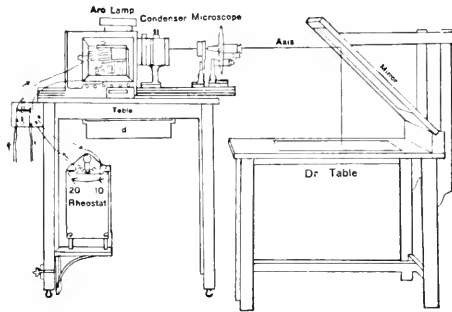

FIG. 246. DRAWING AND PROJECTION OUTFIT WITH LARGE MIRROR ON SEPARATE DRAWING TABLE.

For full explanation see Fig. 112. Instead of the arc lamp here shown the 6-volt incandescent lamp can be used for most purposes (§676).

wires instead of in heating the filament to supply the light.

It is also a good plan to have the wires between the transformer and the lamp as short as possible and not be inconvenient.

§ 677. **Arrangement of the lamp for the large projection outfit.** — If the lamp is to be used in the lamp-house instead of an arc lamp for the large projection outfit, it must be centered carefully and put the right distance from the large condenser. The filament takes the place of the crater of the arc lamp and hence should be in the focus of the first element of the condenser, so that the beam between the first and second elements of the condenser will be approximately parallel.

If a two-lens condenser is used the lamp filament is slightly within the focus, making the light slightly diverging between the two lenses of the condenser.

with a 6-volt current must be 72 divided by 6 or 12 amperes. For the 108-watt lamp in like manner the amperage is the wattage divided by the voltage, — 108 divided by 6 = 18 amperes. This shows at once why the large wires must be used between the lamp and the transformer. If the usual small wires are used the resistance is too great and part of the energy is used up in heating the

A concave mirror or reflector behind the lamp is of considerable advantage, for the light which extends backward is reflected forward to the condenser and is thus available for illuminating the object.

§ 678. **Large condenser for drawing.** — If the three-lens condenser is used (fig. 111), and it is much to be preferred, the second element which converges the parallel beam should be of long focus. One of 38 cm. (15 in.) focus has been found very satisfactory. The reason for using the long focus lens is discussed in Ch. VI, § 297, fig. 115.

If a two-lens condenser is used the second element should also be of longer focus than for ordinary magic lantern work, for the same reason as for the three-lens condenser.

§ 679. **Drawing with the small projection outfit.** — If one has no large projection outfit, drawings for models and for publication can be made very satisfactorily with the 6-volt lamp as follows: It is a great advantage to have the lamp in one of the metal lanterns like those used for daylight glass (fig. 37-38), then scattered light will be avoided. There should be a condenser like that used for the small arc lamp (fig. 49). It should be over one of the daylight glass openings and of course centered with the lamp filament. If it were in a tube which permitted of a limited amount of movement, as with the condenser of the small arc lamp, it would be of much advantage. As the microscope must be horizontal and is ordinarily raised to make the drawing distance 250 mm., the lantern containing the 6-volt lamp must be supported on a box or block to bring the filament of the lamp in the optic axis of the microscope.

When horizontal the microscope is unstable; hence a weight or better a clamp is put over the feet to hold the microscope firmly so that when once centered it will not move easily. A table with the drawing shelf on the legs is very convenient for getting the desired magnification (fig. 247).

§ 680. **Relative position of the lamp and microscope.** — This can be as with the small drawing outfit and arc lamp (fig. 113), or it can be put in line, as with the large outfit. If in line (fig. 111) the mirror is not used, and care must be taken to get all parts lined up to one axis. With the mirror slight deviations from centering can be overcome by inclining the mirror accordingly.

§ 681. **Condensers to use with the small outfit.** — For low powers, 50 to 16 mm., the substage condenser of the microscope can be turned aside and the small condenser with the lamp alone employed. In many cases no ocular is used for the sake of the large field. For powers of 8 to 2 mm. when the ocular is used it is necessary to use the substage condenser to light with the proper aperture. And if the oil immersion is used it is a great advantage to make the substage con-

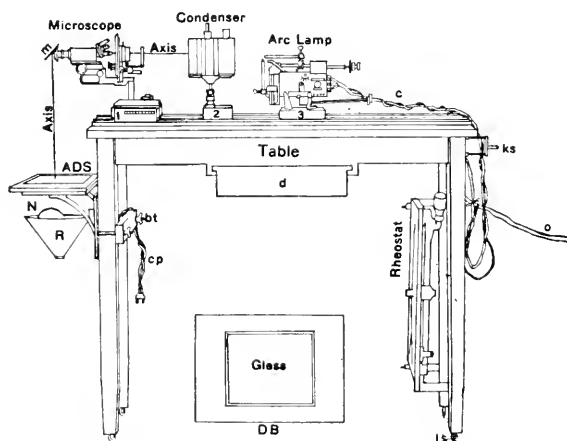

FIG. 247. DRAWING AND PROJECTION OUTFIT.

For full explanation see Fig. 109. For drawing the 6-volt lamp can well take the place of the arc lamp here shown (§676).

denser homogeneous immersion also; that is, to have some of the homogeneous immersion fluid between the lower side of the slide and the condenser as well as between the objective and the cover-glass (§ 471).

§ 682. **Making the drawings.** — One can draw directly upon blotting paper, but it is so important to have a drawing to refer back to that one or more duplicates should be made. This is easily accomplished by putting a sheet of carbon manifolding paper on the blotting paper and a sheet of thin paper over the carbon paper, using thumb-tacks to hold the blotting paper and the duplicating sheets in position.

One should take the precaution to number each drawing as it is made; then confusion in the later processes will be avoided.

§ 683. **Cutting out the sheets for the model.** — “With the blotting paper, if the drawings are small the cutting is easily done with scissors or a knife. When the drawings are large and especially when the model is to be made by representing each section by two or more thicknesses of blotting paper, it has been found that an ordinary sewing machine can be used to do the cutting. By setting the regulator for the shortest stitch, an almost continuous cut is made and the parts are easily separated. If a large sewing-machine needle is sharpened in the form of a chisel, the cut becomes considerably smoother. It has been found advantageous when long continued or heavy work is to be done to attach to the machine an electric sewing-machine motor. Skill in guiding the work is soon acquired. There are some details of a complicated drawing which are more easily cut by the scissors or a knife after the main lines have been cut by the machine.”

§ 684. **Contrasting colors for marking groups of sections.** — “It is a great advantage in any working model to have sections at regular intervals in marked contrast with the body of the material. Blotting paper of a large variety of colors (black, red, blue, pink) is easily obtained in the market. In the models made every tenth plate was a bright or light color and every one-hundredth was black, rendering rapid numeration easy.”

§ 685. **Putting the sheets together to make the model.** — “When the paper sections are thus prepared they are piled and repiled as is usual until the shape conforms to an outline predetermined from photographs, drawings, or measurements made before the specimen was cut.”

“It has been found that an easily prepared support and guide for the model in process of setting up is made by cutting the outline to be followed from a block of four or five sheets of blotting paper, marking upon it the lines of direction of every tenth or twentieth section. The colored numerating plates must of course conform to the spacing and direction of these lines.”

"The preliminary shaping having been accomplished, more exact modeling is undertaken. The paper sections slide very easily upon one another. The most satisfactory means of fastening them together is by the use of ribbon pins, ordinary pins, or wire nails of various sizes, depending on the size of the model. No kind of paste or glue was found suitable for this purpose."

§ 686. **Finishing the model.** — "When the model is well formed, inequalities are best removed by rubbing with the edge of a dull knife and smoothing with sandpaper. Any dissections of the model for showing internal structures should be planned for at this stage, for it is now more easily separated than later. It is also at this time that superfluous 'bridges,' which have been left in place to support detached parts, would better be removed."

"To finish the model it is held together firmly and coated with hot paraffin either by a camel's hair brush or by dipping in paraffin and removing the superfluous coating by a hot instrument. One might use a thermo-cautery for this purpose."

"The paraffin renders the model almost of the toughness of wood without destroying the lightness of the paper."

§ 687. **Coloring the surface; dissecting the model.** — "For coloring the surface of the model, it was found most desirable to use Japanese bibulous paper, lens paper (§ 158) which had been dipped in water color and dried. Any of the laboratory dyes or inks can be used, such as eosin, picric acid, methylene green, black ink, etc. The colored lens paper molds over the surface with ease and is held in place by painting with hot paraffin. All color and enumeration lines and fine modeling show through the transparent paper."

"When the model ceases to be a working model it can be covered with oil paints mixed with hot paraffin and rubbed to any degree of finish desired."

"One can dissect a model by a hot knife run along the planes of cleavage or cut across them by a saw."

For the literature of blotting models see: Susanna Phelps Gage, *Amer. Jour. Anat.*, vol. v, 1906, p. xxiii; *Proceedings of the International Zoological Congress for 1907*; *Anatomical Record*, Nov.

1907. (From this paper the above quotations were made.) *Zeit. wiss. Mikroskopie*, Bd. xxv, 1908, pp. 73-75.

Blotting-paper models have also been made and demonstrated by Dr. J. H. Hathaway and by Dr. J. B. Johnston at the Association of American Anatomists, 1906 (*Proc. Assoc. Amer. Anatomists*, *Anat. Record*, April 1, 1907); in 1909 by Dr. J. Parsons Schaeffer (*Anat. Record*, 1910); and in 1916 by Dr. Charles Brookover and Dr. H. Saxon Burr (*Anat. Record*, 1917).

CHAPTER XII

BRIEF HISTORY OF LENSES AND MICROSCOPES

IN works and papers dealing with the history of the microscope, it seems to the writer that undue prominence is given to the mere mechanical supports and arrangements for focusing the optical parts. These were legion, and they are being improved year by year even faster than the optical parts. The mechanical parts are not to be belittled, but after all it is the optical parts that make a microscope, and some of the most fundamental work of the world in the microscopical field has been accomplished with instruments which now seem very unattractive mechanically.

The mechanical parts of the microscope have been figured and described fully in the *Journal of the Royal Microscopical Society*; in Harting's work on the microscope, and in the histories of Mayall and Petri.¹

It is hoped that by dealing with the optical parts only the reader will gain a connected and comprehensive view of the main steps which have been taken in bringing about the optical instruments of the present day.

§ 690. **Lenses.** — It is difficult to think of a world without lenses. All apparatus like the moving picture machine, magic lantern, photographic camera, the microscope and telescope and spectacles, would be no more. But it is not to be forgotten that the most splendid creations in the world of art, as that of the Greeks; and in the world of literature, as that of the Hebrews, the Greeks, and the Romans; the architecture of the Orient, of Egypt, Greece and Rome; and the feats of engineering of the ancient world were all independent of

¹ The author wishes to express his appreciation of the help given by Dr. A. C. White, of the Cornell University Library, in translating passages from the Greek and Latin works bearing upon optics and vision.

lenses and the optical instruments which they make possible. But what immeasurably greater insight into the real world has come with these "optic glasses"! What revelations as to the cause of disease, of the structure of the universe in its smallest details by the microscope, and in its larger ranges by the telescope; and greatest of all for the common man, has come the power, by means of spectacles, to make good use of the years that hygiene has added to the average human life.

That nature made lenses during every rain-storm and every heavy dew and in the tears of every gum and balsam tree, we know now; and for the almost infinite years which man has been upon the earth, the learned and the ignorant were equally unmindful of the marvel before their very eyes; as unmindful as are the vast majority of men and women at the present day.

All who have made a study of the question are unanimous in the opinion that optical instruments, other than mirrors, were unknown to the ancient world; and that lenses were wholly unknown. Some, however, find in the disc of quartz in the British Museum and known as the Assyrian "lens," and dating from about 700 B.C., evidence that lenses were made before the Christian era. How one who actually sees this disc of quartz can think of it as a lens is inconceivable to me. Mayall, who had an opportunity to study it, decides wholly against the lens theory. In his work on the history of the microscope, p. 5, he gives a face and an edge view of it.

In the first and second centuries of the Christian era there was an abundance of knowledge of mathematics and of optics to make possible the invention of the simple microscope and of appreciating it as such. In works of literature there are hints that men were on the track. For example, Seneca, in his *Questiones Naturales* (L. I, q. 6), says that "Letters however small and dim are comparatively large and distinct when seen through a glass globe filled with water," and that apples in a vase of water are far more beautiful. He is trying to account for the size of the rainbow and sums it all up by saying that, "anything, in fact, that is seen through moisture appears far larger than in reality it is." To Seneca the magnification was the effect of the water and not the effect of the refraction at curved surfaces.

Turning now from the literature of this period to the work of Claudius Ptolemæus (70-147 A.D.) on optics, one is filled with admiration for the exactness of knowledge displayed. He stated with a clearness never since excelled the laws of refraction of light in passing from transparent media of different density, and dealt with curved as well as with plane surfaces (*Sermo Quintus*). It is almost inconceivable that he should not have discovered the magnifying power of curved bodies from their refractive action. A part of this discussion is lost, but so far as known he did not make that discovery.

In works dealing with the history of optics frequent reference is made to Alhazen "On Appearances." This work is supposed to date from about 1100 A.D. It was translated from the Arabic by Risner in 1572. Almost all of its sound teaching in optics conforms very closely with that of Ptolemæus whom Alhazen mentions. The structure and action of the eye is founded almost entirely on the work of Galen. In using Alhazen one should note carefully what is said by Risner in the preface, for it seems quite possible from his statement that he might unconsciously have read into his translation knowledge of optics which was a later acquisition; in a word in trying to make clear the work of Alhazen, possibly a certain amount of later knowledge was added to it.

In passing it may be said in reading almost any of the ancient writers and indeed all large publications of a single author, that they are in the nature of cyclopedias, detailing the knowledge most in favor at the time and often containing a certain amount of original matter. The older the work the greater the proportion of original matter if the author is of first rate ability, because until recently there have not been the periodicals and transactions of learned societies in which to publish one's original contributions.

The first clear and unmistakable statements from which dates modern knowledge of lenses and their action are found in the works of Roger Bacon; especially his *Opus Majus*, 1266-1267. Roger Bacon's work is encyclopedic in many ways, and in many it is like a modern monograph, giving full recognition of the opinions and work of others. In his works (*Opus Majus*; *Opus Tertium*, etc.) lenses are figured and discussed in detail. Bacon nowhere claims to be the

inventor of lenses. He expounds the principles on which they act, referring back to Ptolemaeus for the laws of refraction so clearly set forth by him. And he discusses over and over again the marvelous things which lenses enable one to do. Nearly all of the things mentioned by Bacon we know are possible from our own experience. He tells us that much of his private fortune was spent in obtaining apparatus of all kinds, for he insisted that the final test in science is experiment.

He pointed out that convex lenses made it possible for old men to read the smallest letters, and within thirty-two years from that time, i.e., in 1299, we have in a manuscript this notable sentence: "I am so affected by years that I cannot read or write without the glasses they call spectacles, lately found out for the benefit of old men when their eyesight gets weak" (Carpenter-Dallinger, p. 118, Harting, III, p. 16).

§ 691. **Spectacles.** — It is rather surprising that the use of spectacles became so general in so short a time after Bacon had sent his manuscript to Pope Clement IV. The part on optics (*Perspectiva*) was copied many times and widely distributed among the libraries. It is referred to by many writers, e.g. Porta, Maurolycus, Kepler, Scheiner, etc. Apparently, then, it was available for any one who was interested greatly in optics. For over 300 years from the time of Roger Bacon practically all of the work in optics was in the hands of the spectacle makers, and to them we owe both the telescope and the microscope and the lenses for the camera obscura and the magic lantern (§ 701-704).

§ 692. **Concave spectacles.** — Roger Bacon knew concave as well as convex lenses, but he did not refer to the use of concave lenses for people with short sight (*myopia*) so far as I have been able to find out. Just who made this discovery has never been shown. However, within 200 years from the first statements in the *Opus Majus* concerning the use of convex glasses for old men, mention becomes more and more common of concave glasses for the myopes, and from 1568 onward convex and concave spectacles have a fixed place as aids to vision. See Barbaro, § 705a, and the works of Pansier, p. 29-31, and Bock, p. 44.

§ 693. **Cylindrical spectacles — astigmatism.** — The use of spectacles for defective vision was, until quite recently, confined to those with long sight or short sight, and spherical convex or concave lenses were used. Two English astronomers and physicists (Thomas Young, 1800, and George B. Airy, 1825) found that the curvature in their eyes were not equal and consequently lines in one plane focused at one level and in another plane at a different level. To correct this defect Young pointed out that the spectacles might be tilted, and Airy that the best way was to use cylindrical glasses which would just neutralize the unequal curvature. Probably this discovery of astigmatism and the means for its correction has and is destined to accomplish greater good to the human race than any other optical device of the 19th century.

Some little space has been devoted to spectacles because the eyes are a fundamental part of any optical combination like the microscope or telescope and is the judge of the real images produced by any optical train like the photographic camera, the magic lantern and the moving picture machine, therefore whatever pertains to the eye and its natural perfection or artificial means of making it more perfect, is germane to the subject.

§ 694. **Simple microscope.** — Every convex lens is or may be used as a microscope, as it aids the eye in seeing an object under an increased visual angle, and hence makes it appear larger than it would if viewed by the naked eye. Hence, when considering the history of the simple microscope it is evident that that history is the same as the history of convex lenses. The date of the invention is some time before the date of the *Opus Majus* of Roger Bacon. He speaks of them, not as a wholly new invention of his own time, but as one of the means by which wonderful things can be done. His whole purpose in the discussion was to induce the church to make the fullest use of all the products of science to give the superiority which he felt was the right and the privilege of the Christian world to possess in its efforts for advancing civilization.

The simple lens or the combination of lenses making up a simple microscope may be held in the hand, but ordinarily there is some metal binding and support for the protection of the lens or lenses, and

their easier handling or focusing. The common reading glass with its convenient handle (fig. 4) and the tripod (fig. 201) and focusing lens holder (fig. 202) are good examples.

In reading the older literature one often meets with the expression "single microscope." This means a simple microscope, composed of one lens (fig. 182), and is in contrast with the "double microscope," or compound microscope of two lenses or two combinations (objective and ocular, fig. 248-249).

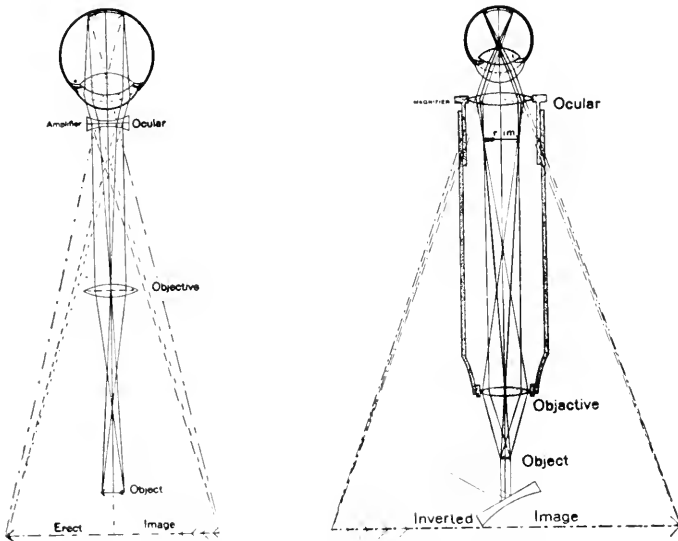

FIG. 248, 249. DUTCH AND KEPLERIAN COMPOUND MICROSCOPES FOR COMPARISON.

Each has a convex lens for objective. For ocular the Dutch form has a concave and the Keplerian form a convex lens. The ocular for the Keplerian form is properly a magnifier of the real image, while the concave-lens ocular of the Dutch microscope acts as an amplifier for the objective.

The virtual image is erect with the Dutch, but inverted with the Keplerian microscope.

§ 695. **The Dutch compound microscope.** — So far as known at present the first compound microscope invented was composed of two lenses, a convex lens for the objective and a concave lens for the

ocular (fig. 248). The convex lens is placed to give a real image of the object, that is, the object is outside the principal focus of the objective (fig. 248). But before the real image is formed a concave lens (the ocular) is placed in the path of the beam. This makes the rays less convergent and therefore acts as an amplifier to increase the size of the real image of the objective. The eye is placed close to the ocular and focuses the real image on the retina. This retinal image is inverted (fig. 5-6) and therefore when projected out into space it seems erect (fig. 248), as with the simple microscope (fig. 182).

From the testimony of eye-witnesses this form of compound microscope was devised by a spectacle maker in Middleburg, Holland, about the year 1590, the name of the inventor being Zacharias Jansen. (See Borellus.)

Very early the two lenses were put into tubes and made capable of being brought together or separated, depending upon the distance of the object to be examined. The nearer the object the farther apart must be the ocular and objective. There still remains in the ordinary opera glass the original Dutch telescope. If one has an opera glass it is easily demonstrated that it can be used as a microscope by unscrewing the ocular so that it may be separated a considerable distance from the objective. If now the objective is held within 10 to 20 centimeters of an object and the ocular moved back and forth along the axis, the place will be soon found where the image is distinct and it will be seen much enlarged.

The name telescope was given sometime before 1618, and the designation microscope in 1825 (§ 2a). As every one who used the instrument found that it could be used as a microscope or as a telescope it soon came to be called a telescope-microscope, or a microscope-telescope.

§ 696. **The Keplerian compound microscope.** — When the Dutch telescope came to the attention of the astronomer and optician, Kepler, he very quickly saw that the same effect could be brought about by using a convex ocular as well as a convex objective, but that the image would be inverted, the objective serving to produce an enlarged real image and the ocular to magnify that image.

The demonstration of the principles on which such a microscope or telescope could be constructed is to be found in the *Dioptrica* of Kepler, Proposition LXXXVI. The proposition is: With two convex lenses to show objects larger and inverted.

In Prop. LXXXIX, it is stated that with three convex lenses can be shown objects enlarged and erect. This is the principle of the terrestrial or erecting telescope.

Kepler first showed the real action of the eye as an optical instrument, and that the retinal image must be inverted, and that unless inverted, objects would appear wrong side up. Now we know that is true, for it is an easy demonstration to show, as did Scheiner in 1619-1625, that the retinal image is actually inverted in the eye of an animal or man.

As Kepler showed the actual dioptrics of the eye, he was the first to explain the real action of spectacles in correcting the defects of long sight and short sight, viz. to aid the refracting surfaces of the eye to make a sharp image of the object upon the retina.

While Kepler gave the optical demonstration for a microscope or telescope with convex lenses, he, so far as known, did not actually construct such a microscope or telescope. Christopher Scheiner, while he lacked the original genius of Kepler for discovering and expounding principles, had greater mechanical ability. He actually constructed the Keplerian telescope and microscope and used them both for observation and for projecting real images. On page 130 of the *Rosa Ursinae* (1626-1630) occurs this remarkable passage: "In the same way [i.e. by two convex lenses] was produced that *wonderful microscope* by which a fly was made as large as an elephant and a flea to the size of a camel."

§ 697. **Binocular microscopes.** — From the first invention of the telescope-microscope there was dissatisfaction that it was for but one eye, and before 1610 there were made those for both eyes by putting two equal instruments side by side the right distance apart for the eyes of the observer. That arrangement of the Dutch telescope still holds in opera glasses.

One of the first examples shown in pictured form is that of the

Cherubin d'Orleans in 1677 (fig. 250). This, as seen from the picture, is a binocular Keplerian microscope, or rather two of them, as both objectives and oculars are of convex lenses. The objectives needing to be close together makes a divergence of the tubes necessary to get the right pupillary distance for the oculars. In general this form of binocular has been recently revived for dissection, only in the modern form achromatic objectives are used and Huygenian oculars, and by means of prisms the image is made erect.

Only rather large objects can be studied with such binoculars, and the effort to divide the light from a single objective reached success only as late as 1851, when it was worked out by J. L. Riddell of New Orleans. His description and a figure were published in the Quarterly Journal of Microscopical Science in 1854. From that time on success-

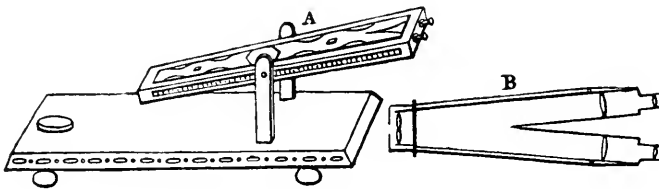

FIG. 250. BINOCULAR MICROSCOPE OF CHERUBIN D'ORLEANS.

ful binocular microscopes have been made. The one of Wenham (fig. 52) in England (1860) enjoyed the greatest favor. Tolles in 1864-1865 produced his binocular eye-piece, and Nacet, in France, and Zeiss, in Germany, produced binocular instruments, but there were defects inherent in the construction of all forms, especially the defect that they could not be used very satisfactorily with high powers, and they were expensive. Finally, in 1902, Mr. F. E. Ives figured and described a form of binocular suitable for all powers including the highest oil immersions (§ 142, 150). Several recent models have been produced in which the principles he enunciated so clearly have been incorporated (fig. 53, 54, 55).

In the first binoculars of the Dutch form the tubes were parallel, as with the opera glass, but in many of the later forms (fig. 52, 250) and many others the tubes were made divergent. With others, as

the binoculars of Nachet (1853) and Harting (1858), the tubes are parallel (§ 144).

§ 698. **Microscopes for two or more observers.** — The projection microscope with its real images on a screen has been commended from the first invention of projection apparatus because many can see the image at the same time, and the teacher or exhibitor can be sure that the observers are seeing the special things he wishes to show. But in looking into the microscope in the ordinary way only one person can look at a time, even with the ordinary binocular. Therefore there arose the effort to divide the light from the object so that two or more could see the same image at the same time. The use of prisms for dividing the light in the binocular gave the hint, and in 1853 Nachet constructed a microscope for two observers, and another for three observers (see figures of these in Harting and in Robin's work on the microscope, also in the original paper). Harting, 1858, also produced a microscope for two observers. For this the tubes were parallel. By putting them closer together they served for a binocular for one person.

Finally, in his enthusiasm for demonstration, he constructed a microscope in which the beam was divided among four diverging tubes so that four persons could see the same specimen at once.

Within recent years the demand for a way by which two observers could look at once has given rise to two very practical double oculars which are far enough apart so that two can look into the oculars conveniently. One was devised (1910) by Dr. Edinger of Frankfurt and produced by Ernst Leitz in Germany, and the other in 1916, by the Spencer Lens Company of Buffalo, New York. In both these double oculars there is an adjustable pointer so that the exact structure which is to be studied can be indicated; then both teacher and student can be sure that they are talking about the same thing.

§ 699. **Oculars.** — As shown above the first oculars were of single lenses, — for the Dutch telescope-microscope a concave lens, and for the Keplerian microscope a convex lens.

For the Keplerian microscope, which soon became the only one used for microscopic work, all sorts of experiments were tried both for oculars and for objectives. Finally, about 1660, Huygens, the great Dutch astronomer and physicist, designed for the telescope

the ocular (fig. 23-24) which now bears his name. It was soon adopted for the microscope and is to this day the most used of any.

The Ramsden ocular was devised by J. Ramsden (1782) for the telescope and like the Huygenian was adapted to the microscope. It has been used especially for the ocular micrometer (fig. 22 A, 93).

The Compensation oculars were invented by Abbe (1885-1886) to go with the apochromatic objectives and to correct the residual defects in the objectives (fig. 22 B, 174-175).

§ 700. **Mirrors and condensers for illuminating objects.** — The first objects looked at through the microscope, whether simple or

compound, were opaque and must be illuminated by light falling upon their surface. For this were used condensing lenses, plane and concave mirrors. The origin of the mirror is prehistoric. The first were of polished metal and of dark minerals. Those with a metal backing have been known only since about the 12th or 13th century, and those with silver only since about 100 years ago. It is not to be forgotten that still water and other smooth objects in nature serve as mirrors, and have always existed.

In Descartes' picture of the Dutch compound microscope (fig. 251) there is a parabolic mirror for lighting the object if opaque, and a condensing lens for transparent objects. Descartes also gives a picture of a

simple microscope with a similar concave mirror for illuminating the opaque object (fig. 252). In 1668 Hooke speaks of looking-glasses

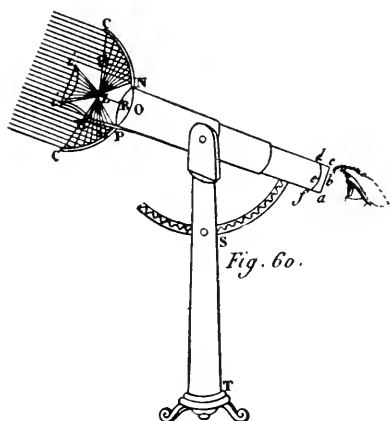

FIG. 251. DESCARTES' DUTCH COMPOUND MICROSCOPE WITH A PARABOLIC MIRROR AND A CONDENSING LENS.

abc, def. Concave ocular (amplifier).

S T Stand and circle holding the microscope and pointing it toward the sun or other light source.

N O P Convex objective.

C C Parabolic mirror for illuminating opaque objects.

i i Condenser for illuminating transparent objects.

for illuminating transparent objects for projection. The first pictures of compound microscopes with the mirror, as at present under the stage, are by Hertzell (1712) and Marshall (1718).

A condenser of a single lens or of a combination of lenses for transparent objects dates from the earliest use of the compound microscope, as shown by Descartes' figure. Its importance for adequate lighting has never been lost sight of, as indicated by Brewster (§ 100a) and by Nelson (see in collateral reading); and never so thoroughly appreciated as at the present day. The form most common on microscopes is the uncorrected one of Abbe which was first described in the *Archiv für Mikr. Anat.* Vol. 9, 1873, p. 469.

§ 701. **Achromatization.** — As pointed out in § 463-464, white light, being composed of different wave lengths (fig. 144-146), must be differently refracted when passed through a prism or lens. To the normal human eye the different waves when separated or dispersed out into groups appear of different colors. Although the nomenclature used by Newton was somewhat different from that now used, he supposed that the refraction of the different waves was in exact accordance with their wave lengths, as is the case with a diffraction grating, and hence there could be no achromatization of dioptric instruments, for when the dispersion was overcome the refraction must also be eliminated. The mistaken belief that the human eye was achromatic, however, kept alive the hope of producing achromatic microscopes and telescopes. Experiments on a large number of transparent substances showed that while all dispersed the light, the dispersion was not the same in all, some affecting one group out of proportion to another. This irregularity gave the clue to the way to

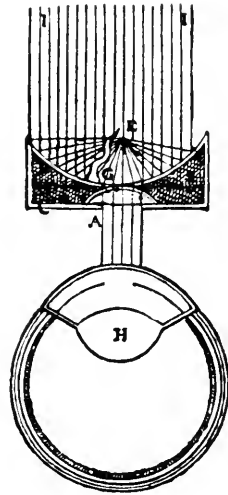

FIG. 252. DESCARTES' SIMPLE MICROSCOPE.

II Rays of light passing to the reflector.

C The parabolic reflector for illuminating the opaque object.

A The plano-convex lens serving as a magnifier.

G E Pin for holding the opaque object.

H. Crystalline lens of the eye.

accomplish achromatism, for if two or more transparent bodies could be combined and neutralize their dispersive effect without overcoming the mean refraction it would be possible to make achromatic combinations. This is shown by the course of the beam of white light traversing the two prisms (fig. 172). The first to accomplish the feat in a way to make achromatic telescopes possible was John Dollond (1757). Naturally the telescope took the lead in the improvement, as it at that time was by far the most important optical instrument. Furthermore, the lenses were relatively large; for in the differentiation of the telescope and microscope the objective of the telescope became progressively larger and that for the microscope progressively smaller. The smaller the lenses the more perfect must be the grinding and polishing, for slight imperfections in their small area introduce obscurations which in the larger surface of the telescope lenses would be negligible (§ 476, fig. 180). But the microscope makers undertook the task in several different countries, — England, France, Russia, Holland, Germany, and Italy — and from 1759 to 1824 were tireless in their efforts. Finally Selligie laid before the French Academy the result of his efforts with the help of the practical opticians, Vincent and Charles Chevalier. From that time on achromatic objectives became more and more common for microscopes, although from their small aperture they were not liked by some workers so well as the more brilliant, uncorrected lenses.

In our own country, Charles A. Spencer took the lead in trying to overcome the lack of brilliancy in achromatic objectives. He too, early realized and grasped the importance of aperture for the microscopic objective. He realized also that for the balancing of the dispersions and refractions to make true achromatic combinations, it was necessary to have materials for lenses with special properties. He worked in two directions. One was the use of the natural mineral fluorite whose properties had been pointed out by Brewster (§ 465a) and the other was the production of new forms of glass with specially desired optical qualities.

It fills one with admiration to think of this genius with small means working alone in his cramped quarters trying to make new forms of glass, which with the old forms and with natural minerals would enable

him to produce the objectives of his dream with large aperture and perfect color and spherical correction. While his success, and that of his pupil Tolles, were certainly great in producing the highest type of objective for the telescope and microscope with the materials already to be had, his glass making did not bring him all that he wanted. It was reserved for the optical works of Zeiss and the genius of Abbe, with the help of the practical glass maker Schott, and the liberality of the German government to finally overcome the difficulties in making new forms of glass with specially desired qualities of dispersion and refraction; and even then it was necessary to go back to the natural mineral fluorite to make possible the apochromatic objectives. Those interested are recommended to read the work of Hovestadt on the new Jena glass.

§ 702. **Immersion objectives.** — In the development of any art the science needed almost always lags behind, and is developed in most cases to explain what has already been discovered by the hard and roundabout method of "trial and error." This was the case with immersion objectives. Amici in Italy and David Brewster in Great Britain were busy in trying to improve microscope objectives by any feasible method. They used all sorts of liquids for immersion. Water was one of the most successful and still holds its own.

§ 703. **Homogeneous immersion objectives.** — The advantage of the immersion principle gradually became understood to be the possibility of increasing the aperture under which the object could be viewed. The final step by which the aperture could be pushed to the limit of human skill in figuring the lenses came when Mr. Tolles (1871-1874) showed in the clearest manner the possibility of making such objectives and increasing the aperture by means of homogeneous contact between the condenser and the slide or object and between the object or cover-glass and the front lens of the objective. The matter is well stated by Hon. J. D. Cox in his presidential address before the American Microscopical Society for 1884 (pp. 5-39), and in Mr. Mayall's Cantor Lectures on the History of the Microscope (1885). On p. 96 Mayall says: "If priority of publication of the formula on which homogeneous immersion objectives could be produced carries with it the title of inventor, then Mr. R. B. Tolles stands alone as

inventor; but he not only published the formula, he constructed objectives on it." The formula was submitted with the objective in 1874. The homogeneous immersion objectives of Zeiss came out in 1878.

Many substances have been tried for the homogeneous fluid. Thickened cedar-wood oil has proved most satisfactory. Mr. Tolles used Canada balsam; if one gets out of cedar-wood oil and has Canada balsam of moderate thickness, good results can be obtained by using the balsam as an immersion liquid.

§ 704. **Projection microscope.** — The production of real images by means of a naked aperture and by means of a lens were the beginnings of the magic lantern, the photographic camera, the *projection microscope*, and the drawing camera.

As shown elsewhere (Optic Projection, p. 673), the production of real images in dark places by means of an aperture or hole in the wall is a purely natural phenomenon. The systematic utilization of this phenomenon by man had its beginnings in the sixteenth and seventeenth centuries. The first certain statement of the use of a lens in the aperture to make the picture clear and vivid occurs in the work of Daniel Barbaro on perspective (§ 705a).

From this time on a lens is always used for projection. At first the images were smaller than the object, as naturally only the brightly lighted objects in the exterior world were projected, but as artificial and natural light were used to illuminate smaller and smaller objects, many of which were transparent, and the projection lenses were made of shorter focus, the images became larger than the object. Finally (1665), when the apparatus became small, and only the object and lens and light were enclosed and the image was on a screen outside, the magnifying action seemed like that of a microscope, and Milliet de Chales, in speaking of the magic lantern of Walgensten, says (Vol. II, p. 667): "In this machine you have a kind of microscope," and Zahn, p. 255, in discussing the magic lantern, says: "It is a kind of a microscope." Both authors point out the great advantage this kind of a microscope has over the ordinary one in that many persons can see the image at the same time. Kepler (1611) showed that the Dutch telescope-microscope could be used for projecting images

and also his own combination of convex lenses. Scheiner (1626-1630) used them for projecting images of the sun so that he could draw the spots. See also Hooke, *Trans. Roy. Soc.*, 1668, p. 741.

Naturally, with the perfecting of objectives (1824 and onward), and the finding of more powerful artificial lights (lime light, 1824, electric light, especially since 1880), the projection microscope is coming to be used more and more.

§ 705. **Drawing magnified images.** — The first drawings made by the aid of the microscope were free-hand. Examples of the drawings may be seen in the work of Borellus, and in facsimiles shown in the *Journal of the Royal Microscopical Society*, 1915, pp. 317-340. The desire for accuracy and ease in tracing outlines of microscopic images comparable with those so easily attained with the real images of the projection microscope led to the invention of the *camera lucida*, by which the microscopic field and the drawing field, pencil, etc., can be superposed. The first one invented is still used. It is the Wollaston form (fig. 99), and was described by Wollaston in *Nicholson's Journal*, 1807, pp. 1-5. The other form shown in fig. 100 was described in principle by G. Burch, *Jour. Quek Micr. Club*, 1878, p. 47; and by Dippel in the *Bot. Centrbl.* 1882, pp. 242-3.

Drawing with the projection apparatus has been practised from its first invention. Indeed, in all those who described such apparatus, the great help that was to be gained in drawing was emphasized. Both eyes can be used, and perfect freedom of the artist is enjoyed, which is in marked contrast with *camera lucida* drawing. For the early appreciation of projection apparatus and the *camera obscura* for drawing see: Barbaro, 1568 (§ 705a); Kepler, 1611 (§ 705b); Scheiner, 1626-1630; Robert Hooke, 1668; Baker, 1742 (§ 705c); Adams, 1746; Goring and Pritchard, 1837; Chevalier, 1839.

705a. **Daniel Barbaro.** — In his work, *La pratica della prospettiva*, Venice, 1568, Ch. V, p. 192, Barbaro says: "Take an old man's glass, convex on both sides, not concave like the glasses of youths of short sight, fix the convex glass in a hole, close all the windows so that no light may enter except through the lens. Now take a sheet of white paper and bring it toward the lens until all outside the house is clearly seen. When the proper position is found you will see the images on the paper as they are, and the gradations in colors, shadows, movements, clouds, the rippling of waters, birds flying, and everything that can be seen. For this experiment the sun must be clear and bright, for the sunlight has great power in

bringing out the images. You can draw on the paper with a pencil all the perspective, and the shading and coloring according to nature."

705b. Johannes Kepler.— In *Reliquiae Wottonianae*, edited by Izaak Walton, London, 1672 pp. 298-300. In a letter to his kinsman, Francis Bacon: "I have your Lordship's letters dated the 20th of October (1620). I lay a night at Lintz . . . there I found Kepler, a man famous in the sciences, as your Lordship knows, to whom I purpose to convey from hence one of your books [*Novum Organum*], that he may see we have some of our own that can honor our king as well as he has done with his *Harmonica*."

In this man's study I was much taken with a draught of a landskip on a piece of paper, me thought masterly done; whereof enquiring of the author, he bewrayed with a smile, it was himself; adding he had done it, non tanquam pictor, sed tanquam mathematicus [not as an artist but as a mathematician]. This set me on fire: At last he told me how. He hath a little black tent (of which stuff it is not much importing) which he can suddenly set up where he will in a field; and it is convertible (like a windmill) to all quarters at pleasure, capable of not much more than one man, as I conceive, and perhaps at no great ease; exactly close and dark, save at one hole, about an inch and a half in diameter, to which he applies a long perspective trunk [*Dutch Telescope*] with the convex glass fitted to the said hole and the concave taken out at the other end, which extendeth to about the middle of this erected tent; through which the visible radiations of all the objects without are intromitted, falling upon a paper which is accommodated to receive them; and so he traceth them with his pen in their natural appearance, turning his little tent around by degrees till he hath designed the whole aspect of the field. This I have described to your Lordship because I think there might be good use made of it for chorography; for otherwise to make landskips by it were illiberal, though surely no painter could do them so precisely."

§ 705c. Henry Baker.— *The Microscope Made Easy*, 1742. On page 25 occurs this: "Such too as have no skill in drawing may, by this contrivance, [*projection microscope*], easily sketch out the exact figure of an object they have a mind to preserve a picture of; since they need only fasten a paper upon a screen and trace it out thereon either with a pen or pencil as it appears before them."

In glancing backward over the long road which has been traversed in arriving at the present stage with optical instruments, there are two causes for astonishment: First, that mankind was so late in discovering the laws of refraction, and then their application for the production of lenses and their combination into optical instruments; and secondly, the almost fabulous progress that has taken place since the first possibilities of lenses were discovered some six hundred and fifty years ago, and especially during the last three hundred and fifty years since the combination of lenses to make the compound microscope and the telescope was found out.

If the progress in the utilization of lenses for optical instruments of all kinds is as great during the twentieth as it was during the nineteenth century — and there is every reason to believe that it will be even greater — a contemplation of the outcome is enough to fire the imagination, and fill the heart with enthusiasm.

COLLATERAL READING FOR CHAPTER XII

(For the full titles, when not given, see the general bibliography.)

- ABBE, E. — Substage condenser, Apochromatic objectives, etc., Hovestadt and Zeiss catalogues.
- ADAMS, G. — *Micrographia*, 1720-1773. Essays, 1750-1795.
- AIRY, G. B. — On a peculiar defect in the eye and a mode of correcting it. Cambridge Philos. Trans., Vol. II, 1827, pp. 267-271. Here is discussed astigmatism and its correction by cylindrical glasses.
- ALHAZEN. — *The Opticæ Thesaurus*, translated by Risner, 1572.
- BACON, ROGER. — *Opus Majus*, 1266-1267. Combach's edition, 1614. On p. 159 occurs the description of a convex glass to aid old men in reading. Bridges edition, 1897-1900. Vol. II, p. 157, spectacle for old men. *Opus tertium, opus minus*. Brewer, in *Compendium studii philosophiæ*, 1859. Part of the *Opus tertium*, including a fragment now printed for the first time. Edited by A. G. Little, 1912. On p. 40 is repeated the statement about the convex lens for old men, and much other optics.
- BAKER, H. — *Microscopes*, 1742, p. 25.
- BARBARO, DANIEL. — *La pratica della prospettiva*, Venice, 1568.
- BAUSCH & LOMB OPTICAL COMPANY. — *Lenses, their History, theory and manufacture*. Published in honor of the ninth annual convention of the American Association of Opticians. Rochester, 1906. 47 pages, many figures.
- BOCK, E. — *Die Brille (spectacles) und ihre Geschichte*, 1903.
- BORELLUS, PETRUS. — *De vero telescopii inventore*, 1655. Dutch compound microscope by eye-witnesses.
- BREWSTER, SIR DAVID. — *The Edinburgh encyclopædia*, 1832; treatise on the microscope, 1837.
- CARPENTER-DALLINGER. — *Revelations of the Microscope*, 1901.
- COX, HON. J. D. — Robert B. Tolles and the angular aperture question. Deals with the origin of the homogeneous immersion objective also. *Transactions of the Amer. Micr. Soc.*, 1884, pp. 5-39.
- CHEVALIER, CH. — *Des microscopes*, 1839.
- DESCARTES, R. — *Dioptrique*. 1637.
- DOLLOND, J. — *Philos. Trans. Roy. Soc., London*, 1758, pp. 733-743. An account of some experiments concerning the different refrangibility of light. Every one interested in optical instruments ought to read this paper.
- EDINGER. — See for description of the double ocular, *Jour. Roy. Micr. Soc.*, 1911, p. 252.
- GAGE, S. H. & H. P. — *Optic Projection*, 1914.
- Γαλήνος, Κλαύδιος. — *Περὶ χρείας τῶν ἐν ἀνθρώπῳ σώματι μορίων* (Galenus, Claudius. — *De usu partium corporis humani*, 131-201 A.D.).
- GORING & PRITCHARD. — *Micrographia*, 1837.
- HARTING, P. — *Het Mikroskoop*, 1858; *Das Mikroskop*, 2d ed., 1866.

HOOPER, R. — *Philos. Trans. Roy. Soc.*, 1668, p. 741.

HOVESTADT, H. — *Jena Glass*, 1902.

HUYGENS. — For HUYGENS'S ocular see Nelson, *Jour. Roy. Micr. Soc.*, 1900, pp. 162-169.

JOURNAL OF THE ROYAL MICROSCOPICAL SOCIETY. — In nearly every number is the announcement of some new thing pertaining to the microscope. For the special purposes of this chapter attention is called especially to the volume of 1886, pp. 849-856, for the apochromatic objectives; to that of 1889, in which, on pp. 574-598 is a translation of a paper by the eminent Italian physicist, G. Govi, on the invention of the compound microscope. He contends that it was Galileo who first found that the Dutch telescope could also be used as a microscope. This paper may well be read in connection with the book of Borellus.

In 1891, pp. 90-105, Mr. Nelson deals with the substage condenser, and in 1900, pp. 162-169, with the history of the Huygenian ocular. In 1902, pp. 20-23 Mr. Nelson gives a bibliography of works (dated not later than 1700) dealing with the microscope and other optical matters. In 1914 Dr. Jentsch, pp. 1-16, and Conrad Beck, pp. 17-23, 205-210, deal with binocular microscopes, past and present.

In 1915 Charles Singer, pp. 317-340, deals especially with early drawings made by the aid of the microscope; and in 1916, Mr. Heron-Allen and Ch. F. Rousselet give a summary of the progress of knowledge of vision and the microscope from 1673-1848.

KEPLER, J. — *Opera omnia*, Vol. II. See in *Paralipomena*, Caput V, for the action of the eye and of spectacles, especially pages 255-262. And in the *Dioptrica*, pp. 529-556, for the eyes and for combinations of lenses.

MAYALL, J. — *History of the microscope*, 1885.

MILLIET DE CHALES. — *Mundus mathematicus*, 1674. Figure of Walgensten's magic lantern, Vol. II, p. 666.

MOLYNEUX, WM. — *Dioptrica nova*, 1692. Excellent on history.

NACHET. — *Sur un nouveau microscope approprié aux besoins des démonstrations anatomique, et permettant a plusieurs personnes d'observer ensemble*. *Compte rendu des séances de la Société de Biologie*, Oct. 1853. pp. 141-145. In this article is described and illustrated forms of microscopes with two tubes for two observers, and with three tubes for three observers. See also Harting, Vol. III, pp. 243-248. See also plates I-II in the Dutch edition of 1858.

NEWTON, SIR ISAAC. — *Optics*, 1704.

PANSIER, P. — *Histoire des lunettes (spectacles)*, 1901.

PETRI, R. J. — *Das Mikroskop (History)*.

PRIESTLEY, J. — *History. Vision, light, and colors*. 1772.

PTOLEMÆUS, C. — *Optics (70-147 A.D.)*.

POGGENDORFF, J. C. — *Geschichte der Physik*, 1879. *History*.

RAMSDEN, J. — *Philos. Trans. Roy. Soc.*, 1782. A description of a new construc-

tion of eye-glasses (oculars) for such telescopes as may be applied to mathematical instruments. (Pp. 94-98, 1 plate. In Vol. LXXIII, 1783.)

RISNER, J. — See Alhazen.

SCHNEIDER, C. — *Rosa Ursinae*, 1826-1830. Action of the eye, p. 108; The telescope and microscope and projection therewith, p. 130.

SPENCER & TOLLES. — See Krauss, *Trans. Amer. Micr. Soc.*, 1901, pp. 19-29. History of their contributions to microscopy.

TOLLES-SPENCER. — See Cox, *Trans. Amer. Micr. Soc.* 1884, pp. 5-39; Krauss, *Trans. Amer. Micr. Soc.* 1901, pp. 19-29; Mayall, *Hist. Micr.* pp. 95-96.

WALGENSTEN'S magic lantern. Milliet de Chales, *q.v.*

YOUNG, THOMAS. — On the mechanism of the eye, 1800, in *Philos. Trans. Roy. Soc. London*, 1801, pp. 23-88. On pp. 39-40 he describes astigmatism, and shows that it can be corrected by tilting the spectacles. See Airy.

ZAHN, J. — *Oculus artificialis teledioptricus*, etc., 1702. Many figures of optic apparatus at that time.

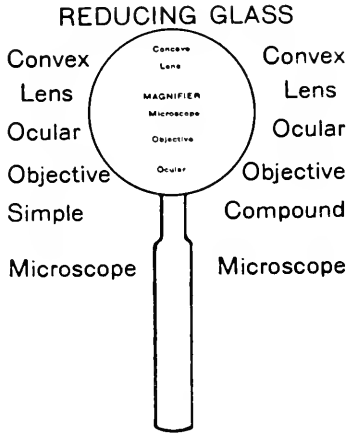

BIBLIOGRAPHY

IN the following list of books and periodicals are mentioned those which have furnished the most helpful information. Those which are still in print usually have the price given.

For new information the reader is advised to consult the *Journal of the Royal Microscopical Society*; the *Index Medicus* and the *Wistar Institute Journals*,—*American Journal of Anatomy*, *Anatomical Record*, *Journal of Morphology*, *Comparative Neurology* and *Journal of Experimental Zoölogy*. For information concerning the development of the science consult the *Index Catalogue of the Surgeon General's Office*, the *Catalogue of Scientific Papers* published by the *Royal Society of London*, the larger works on the microscope, and the microscopical journals, as these furnish a good record.

- ADAMS, GEORGE, 1720-1773. — *Micrographia illustrata*; or, the microscope explained, in several new inventions; likewise a natural history of aerial, terrestrial, and aquatic animals, etc., considered as microscopic objects. lix + 325 pp. 72 plates. Published for the author, London, 1771.
- ADAMS, GEORGE, 1750-1795. — *Essays on the microscope, containing a description of the most improved microscopes, a history of insects, their transformations, peculiar habits, and œconomy, with a catalogue of interesting objects.* xxiii + 724 pp. 31 plates. Published for the author, London, 1787.
- ALHAZEN. — *Opticæ thesaurus Alhazeni Arabis, libri septem, nunc primum editi, ejusdem liber de crepusculis et nubium ascensionibus, item Vitellionis Thuringopoloni, libri X. omnes instaurati, figuris illustrati et aucti, adjectis etiam in Alhazenum commentariis.* A Frederico Risnero. Folio, many figures, Basileæ, per Episcopios. 1572.
- BACON, ROGER. — *Opus Majus*, edited with introduction and analytical table by John Henry Bridges. 2 vols. and supplementary vol. Vol. I, clxxxvii + 440 pp. 23 fig. Vol. II, 568 pp. 187 fig. Supplement, xv + 187 pp. Williams & Norgate, London, 1897-1900. 31s. 6d. For modern optics the part designated *De Scientia Perspectiva* is most important. For use of convex lenses to aid the sight of old men, see vol. ii, p. 157, and for burning flasks, p. 471.
- BACON, ROGER. — *Essays contributed by various writers on the occasion of the commemoration of the seventh centenary of his birth.* Collected and edited by A. G. Little. 426 pp. Clarendon Press, Oxford, England, 1914. Price, \$5.25. *Biography of Bacon and essays upon his work in various fields. List of Bacon's writings.*

- BAKER, HENRY, F. R. S. — *Of Microscopes and Observations made thereby.* 2 vols. New edition. Vol. I, *The Microscope made easy.* Projection microscope. Vol. II, *Employment for the Microscope.* London, 1785.
- BARBARO, DANIEL. — *La pratica della prospettiva di Monsignor Daniel Barbaro, eletto patriarca d'Aquileia.* Opera molto utile a pittori, a scultori & ad architetti. Con privilegio. 208 pp. Many figures. In *Venetia, appresso Camillo & Rutilio Borgomineri fratelli, al segno di S. Giorgio MDLXVIII (1568).* First known user of a lens in the camera. Cap. V, p. 192.
- BAUSCH, E. — *Manipulation of the Microscope.* A manual for the work table and a text-book for beginners in the use of the microscope. 200 pp. Illust. New edition. Rochester, N.Y., 1906. Price \$1.00.
- BEALE, L. S. — *How to Work with the Microscope.* 5th edition, 1880, 518 pages, 99 plates with 500 figures. Harrison, London. Cost 21s.
- BECK, CONRAD. — *The Theory of the Microscope.* Cantor Lectures delivered before the Royal Society of Arts, Nov.–Dec., 1907. 59 pp. Illust. London, 1908.
- BECK, CONRAD, and ANDREWS, HERBERT. — *Photographic Lenses.* 7th edition, completely revised. 287 pp., 163 fig., 44 plates. R. & J. Beck, Limited. 68 Cornhill, London, England. Price 1 shilling. Full discussion of modern objectives for photography and for projection.
- BOCK, DR. EMIL. — *Die Brille und ihre Geschichte.* 62 pages, frontispiece, and 32 text figures. Wien, 1903. Verlag von Josef Safar. Price 4.20 marks.
- BORELLUS, PETRUS. — *De vero Telescopii inventore, cum brevi omnium Conspicilliorum historia.* Ubi de eorum confectione, ac usu, seu de effectibus agitur, novaque quædam circa ea proponuntur. Accessit etiam centuria observationum microscopiarum. Authore Petro Borello, regis christianissimi consiliario, et medico ordinario. Hagæ-Comitum, ex typographia Adriani Vlacq, MDCLV (1655). Important for the history of optic instruments.
- BOYER, CHARLES S. — *The Diatomacæ of Philadelphia and Vicinity.* Quarto, 143 pages, 40 plates (700 drawings by the author at a scale of 800 diameters). Philadelphia, 1916. Press of J. B. Lippincott Company, East Washington Square. Cost \$5.
- BREWSTER, SIR DAVID. — *A Treatise on the Mikroscope.* From the 7th edition of the *Encyclopædia Britannica*, with additions. Illust. 1837.
- BREWSTER, SIR DAVID. — *The Edinburgh Encyclopædia.* Optics, Vol. 14. Joseph and Edward Parker, Philadelphia, 1832. On page 764, 2d column, near middle, is described the use of the amalgam on the back of looking-glasses as a screen. I have tried this and found it wonderfully efficient.
- BURNETT, SAMUEL HOWARD. — *The Clinical Pathology of the Blood of Domesticated Animals.* 156 pp. Ithaca, 1908. 24 figures, 4 colored plates.
- CARPENTER-DALLINGER. — *The Microscope and its Revelations*, by the late William B. Carpenter. 8th edition, in which the 1st seven and the 23d chapters have been entirely rewritten, and the text throughout reconstructed, enlarged, and

- revised by the Rev. W. H. Dallinger. 22 plates and nearly 900 wood engravings. 1181 pp. London and Philadelphia, 1901. P. Blakiston's Son & Co. Price \$8.00.
- CHAMBERLAIN, C. J. — *Methods in Plant Histology*. 3d edition 314 pages, 107 figures. The University of Chicago Press, 1916. Cost \$2.25.
- CHAMOT, ÉMILE MONNIN. — *Elementary Chemical Microscopy*. 410 pages, 1 plate, 139 text figures. John Wiley & Sons, N.Y., 1915. Price \$3.00.
- CHEVALIER, CHARLES. — *Des Microscopes et de leur usage*. Illust. Paris, 1839.
- CLARK, C. H. — *Practical methods in microscopy*. 2d ed. Illust. Boston, 1896.
- COMSTOCK, ANNA BOTSFORD. — *Handbook of Nature Study*. 900 pages, 1000 illustrations. Comstock Publishing Co. Ithaca, N.Y., 6th edition, 1916. Price \$3.25 + 40 cents postage.
- COMSTOCK, JOHN HENRY. — *A Manual for the Study of Insects*. 701 pages. 798 figures, colored frontispiece. Comstock Publishing Company, Ithaca, N.Y. 15th edition, 1917. Price \$3.75 + 32 cents postage.
- CZAPSKI, S. — *Grundzüge der Theorie der optischen Instrumente nach Abbe*. 2 Aufl., unter Mitwirkung des Verfassers und mit Beiträgen von M. v. Rohr. 490 pp. Illust. Leipzig, 1904.
- DANIELL, A. — *A Text-book of the Principles of Physics*. New edition, 1911. The MacMillan Co., London and New York. Cost \$4.00.
- DESCARTES (Lat. Cartesius) RENÉ. — *Œuvres, Publiées par C. Adam et P. Tannery sous les auspices ministere de l'instruction publique*, Vols. i-xii. *Dioptrique*, Vol. 6, pp. 87-228, 73 fig. Leopold Cerf, 12 Rue Sainte Anne, Paris, 1902.
- DESCARTES (Lat. Cartesius), RENÉ. — *Œuvres; publiées par V. Cousin*. Paris, 1824-26. 11 vols. *Dioptrique*, Vol. 5. pp. 1-153, 5 plates, including 66 fig.
- DIPPEL, L. — *Das Mikroskop und seine Anwendung*. Illust. Braunschweig, 1898.
- EHRlich. — *Enzyklopädie der Mikroskopischen Technik*. Herausgegeben von: Ehrlich, Krause, Moose, Rosin und Weigert. 2d edition, 2 Vol., 800 + 680 pages, 56 + 111 figures. Urban & Schwarzenberg, Berlin and Vienna, 1910. Cost 27.50 marks.
- GAGE, S. H. and H. P. — *Optic Projection*. Principles, installation and use of the magic lantern, projection microscope, reflecting lantern and moving picture machine. 731 pages, 413 figures. Comstock Publishing Co. Ithaca, N.Y. 1914. Price \$3.00.
- GORING and PRITCHARD. — *Micrographia*, containing practical essays on reflecting, solar, oxy-hydrogen gas microscopes, micrometers, eye-pieces, etc., etc. 231 pp. Many figures in the text, one plate. Whittaker & Co., Ave-Maria Lane, London, England, 1837.
- GOVI, GILBERTO. — Galileo, the inventor of the compound microscope, — *Journal of the Royal Microscopical Society*, 1889, pp. 574-598. Discussion of the earliest discoveries and inventions in optics. The compound microscope here

- referred to as the invention of Galileo is the Dutch telescope used as a microscope, i.e. an instrument like the ordinary opera glass with a longer tube for the convex objective and concave ocular.
- GUYER, MICHAEL F. — *Animal Micrology*. Practical exercises in Zoölogical micro-technique. 289 pages, 74 figures. The university of Chicago Press, 1917. Price \$2.00.
- HARDESTY, IRVING. — *A Laboratory Guide for Histology*, with a chapter on laboratory drawing, by A. W. Lee. 193 pages, 30 figures. P. Blakiston's Son & Co. Philadelphia, 1908. Cost \$1.50.
- HARTING, P. — *De Nieuwste Verbeteringen van het Mikroskoop en Zijn Gebruik*, Sedert 1850. 176 pages, two triple plates. Te Tiel. bij H. C. A. Campagne, 1858.
- HARTING, P. — *Das Mikroskop*. Theorie, Gebrauch, Geschichte und gegenwärtiger Zustand desselben. Deutsche Originalausgabe, von Verfasser revidirt und vervollständigt. Herausgegeben von Dr. Fr. Wilh. Theile. In drei Bänden. Bd. I, Theorie; Bd. II, Gebrauch; Bd. III, Geschichte. Bd. I, pp. 346, 134 text figures, 1 plate. Bd. II, pp. 310; 104 text figures. Bd. III, pp. 452, 231 text figures. Druck und Verlag von Friedrich Vieweg und Sohn, Braunschweig, Zweite wesentlich verbesserte und vermehrte Auflage, 1866. Price about \$3.50.
- HOGG, J. — *The Microscope, its History, Construction and Application*. 15th ed. 704 pp. 900 Illust. Rutledge, London and New York, 1898. Much attention paid to the polariscope. Cost 10s. 6d.
- HOOKE, ROBERT. — *Animadversions on the Machina Cœlestis of Hevelius*. p. 8. Published in 1674. It is in this place that Hooke states that for two points to be seen as two the visual angle must be one minute.
- HOVESTADT, H. — Translated by J. D. and A. Everett. *Jena Glass and its scientific and industrial applications*. London, MacMillan & Co. Limited. N.Y. The MacMillan Company. 1902. 419 pages, 29 figures. Cost \$4.50.
- HOWELL, WILLIAM H. — *A Text-book of Physiology for Medical Students and Physicians*. 6th edition, 1020 pages, 306 figures. W. B. Saunders Co., Philadelphia, Pa. 1916. Price \$4.00.
- INDEX Catalogue of the Library of the Surgeon General's Office of the United States Army. Government Printing Office, Washington, D.C. First series, vols. i-xvi, 1880-1895. Second series, vols. i-xxi, 1896-1916. Book and periodical literature; subjects and authors in one continuous alphabetical list. Full lists of current literature.
- INDEX MEDICUS. — Carnegie Institute, Washington, D.C. \$8.00 per year.
- JOURNAL OF THE FRANKLIN INSTITUTE, devoted to science and the mechanic arts. 1826 + Philadelphia, Pa. Annual subscription, \$5.00.
- JOURNAL OF THE ROYAL MICROSCOPICAL SOCIETY. 1878 +. Published by the Society at 20 Hanover Square, London W., England. 6 numbers per year; subscription price, 37 shillings 6d.

- JOURNAL OF THE ROYAL SOCIETY OF ARTS. London, England. The 65th volume of the JOURNAL is now being published (1917).
- KEPLER, JOHANNES. — Opera Omnia, Vol. II. Ad Vitellionem Paralipomena. (De modo visionis et humorum oculi usu.) 1604. pp. 226–269. 11 fig. Correct dioptrics of the eye here given, and also the explanation of the effect of convex and concave spectacles. Dioptrica. Demonstratio eorum quæ visui et visibilibus propter conspicilla non ita pridem inventa accidunt. pp. 519–567. 35 fig. 1611. The amplifier, real images, and erect images. The Keplerian microscope (modern microscope).
- KINGSBURY, B. F. — Laboratory Directions in Histology and Histological Technique. pp. 1–60 and 1–95. The MacMillan Co., N.Y. 1916. Price \$1.25.
- LANGERON, M. — Précis de Microscopie; technique, experimentation — diagnostic. 821 pages, 292 figures in the text. Masson et Cie., Paris. 2d edition, 1916. Price 12 francs.
- LEE, A. B. — The Microtome's Vade-mecum. A hand-book of the methods of microscopic anatomy. 7th ed. 526 pp. 1913. P. Blakiston's Son & Co., Philadelphia, Penn. Price, \$4.00.
- LEEUWENHOEK, ANTONY VAN. — Opera omnia, seu arcana nature; ope exactissimorum microscopiorum detecta, experimentes variis comprobata, epistolis ad varios illustres viros. Lugduni Batavorum, 1722, 4 vols. (Delphis Apud Adrianum Beman, 1719.) 1514 + pages, 124 figs.
- LENSES, their History, Theory and Manufacture. Bausch & Lomb Optical Co., Rochester, N.Y., 1906. 47 pp., 34 figs.
- LEWIS and STÖHR. — Textbook of Histology, arranged upon an embryological basis. 2d edition, 1915. 539 pages, 495 illustrations. P. Blakiston's Son & Co., Philadelphia, Penn. Price \$3.00.
- MACMUNX, C. A. — The Spectroscope in Medicine. 325 pp. Illust. London, 1885.
- MALLORY, FRANK BURR and WRIGHT, JAMES HOMER. — Pathological Technique. A practical manual for work in pathological histology and bacteriology. 6th edition, 536 pages, 174 figures. W. B. Saunders Co., Philadelphia, Pa. 1915. Price \$3.00.
- MAYALL, JOHN, JR. — Cantor Lectures on the Microscope, delivered before the Royal Society for the encouragement of arts, manufactures, and commerce. Five lectures, Nov.–Dec. 1885; 97 pp. 103 figs. and two additional lectures in 1888; 18 pp., 26 figs. Published by the Society at John Street, Adelphi, London, W. C., England. Price, 2 shillings 6d, and 1 shilling.
- MILLIET DE CHALES, CLAUDE FRANÇOIS. — Cursus seu mundus mathematicus; nunc primum in lucem prodit. Ex officina Anissoniana, Lugduni [Lyons]. 1674. 3 vols. Folio. The second edition is dated 1690 and has four folio volumes.
- MOLYNEUX, WILLIAM. — Dioptrica nova, a treatise of Dioptricks, in two parts, wherein the various effects and appearances of spheric glasses, both convex

- and concave, single and combined, in telescopes and microscopes, together with the usefulness in many concerns of human life are explained. By William Molyneux of Dublin, Esq. Fellow of the Royal Society. Presented to the R. S. 1690, printed 1692. Much history and translations of Latin extracts. The first figure of a magic lantern with condenser lens.
- MOORE, V. A. — Principles of micro-biology; a treatise on bacteria, fungi, and protozoa pathogenic for domesticated animals, 1912. 506 pages. 101 figures. The MacMillan Co., N.Y. Cost \$3.50.
- MOORE, V. A. and FITCH, C. P. — Exercises in bacteriology and diagnosis for veterinary students. New edition. 154 pages and 10 illustrations. Ginn & Co., Boston, 1914. Price \$1.00
- NEDHAM, J. G. and LLOYD, J. T. — The Life of Inland Waters; an elementary text-book of fresh-water biology for American students. 438 pages, 2 plates and 244 text figures. Comstock Publishing Company. Ithaca, N.Y., 1916. Price \$3.00.
- NEWTON, SIR ISAAC. — Optics, or a treatise of the reflections, refractions inflections and colours of light. 3d edition, 1721. 382 pages, many diagrams. London, England.
- NICHOLS, E. L. — The Outlines of Physics. 452 pp., 414 fig. The Macmillan Co., New York, 1897. Price \$1.40.
- NICHOLS, E. L. and FRANKLIN, W. S. — The Elements of Physics; Light and Sound. 201 pages, 182 figures. The MacMillan Company, New York, 1897.
- PANSIER, P. — Histoire des Lunettes par le Docteur P. Pansier, d'Avignon. 137 pages, 19 figures 6 plates. 1901. Paris, A. Maloine, Éditeur. Price 3 f. 50 c.
- PETRI, R. J. — Das Mikroskop von seinen Anfängen bis zur jetzigen Vervollkommung für alle Freunde dieses Instruments. 248 pp., 191 fig., 2 plates. R. Schoetz, Berlin, Germany, 1896. Price, 10 marks.
- PIERSOL, GEORGE A. — Normal Histology, with special reference to the structure of the human body. 8th edition, 418 pages, 438 illustrations, colored frontispiece. J. B. Lippincott Co., Philadelphia, Pa., 1910. Price \$3.50.
- PRIESTLEY, JOSEPH. — The History and Present State of Discoveries relating to Vision, Light and Colours. 812 pages, 24 plates. Five pages of references to 288 other works. London, 1772.
- PTOLEMEUS, CLAUDIUS. — L'Ottica di Claudio Tolomeo da Eugenio Ammiraglio di Sicilia-Scrittore del Secolo XII. Ridotta in Latino sopra la traduzione Araba di un testo Greco imperfetto. Edited by Gilberto Govi. Torino, 1885. 171 pages, 9 double plates.
- RANVIER, L. — *Traité Technique D'Histologie*. 1109 pages, 379 text figures, and one colored plate. Librairie F. Savy, Paris, France. 1875-1888. Price 30 francs.
- REFERENCE HAND-BOOK OF THE MEDICAL SCIENCES. Albert H. Buck, editor. 8 quarto vols. Illustrated with many plates and figures in the text. New York, 1885-1889. Supplement, 1893. References are to this edition.

- RILEY, WM. A. and JOHANNSEN, O. A. — Hand-book of Medical Entomology. 348 pages, 174 figures. Comstock Publishing Co., Ithaca, N.Y., 1915. Price \$2.00.
- ROBIN, CH. — *Traité du microscope et des injections*. 1101 pages, 336 figures. Bailliere, Paris. 2d edition, 1877. Price, 20 francs.
- ROSENHAIN, DR. WALTER. — *Cantor Lectures on optical glass*. 1916. Royal Society of Arts, London, England.
- RUSBY, H. H. and JELLIFFE, S. E. — *Morphology and Histology of Plants designed especially as a guide to plant analysis and classification, and an introduction to pharmacognosy and vegetable physiol.* 378 pp. 693 figures. New York, 1899.
- SCHIEINER, CHRISTOPHORUS. — *Rosa Ursina sive Sol, ex admirando facularum et macularum suarum phoenomena varius*. A Christophoro Scheiner, Germano sucuo e societate Jesu. Ad Paulum Jordanum II, ursinum Bracciani ducem. 784 folio pages, many plates. Apud Andream Phaeum Typographum Ducalem. Bracciani, 1626-1630.
- SCIENCE, a weekly journal devoted to the advancement of science. N. S., 1895 +. Science Press, Garrison, N.Y. Subscription price \$5.00 per annum.
- SCIENTIFIC AMERICAN, 1845 + and Scientific American Supplement, 1876 +. Published by Munn & Co., 361 Broadway, New York. Weekly Subscription \$3.00, and for the supplement \$5.00.
- SEDGWICK, W. T. and TYLER, H. W. — *A Short History of Science*. The Mac-Millan Co., 1917. Price \$2.50.
- SMITH, ROBERT (LL.D.). — *A Compleat system of opticks*. pp. 458 + 171 of remarks. 63 plates in the text, 20 plates in the remarks. Cambridge, England, 1738.
- SPIITA, E. J. — *Microscopy, the construction, theory and use of the microscope*. 468 pages, 241 text figures and 47 half-tone reproductions of original negatives. John Murray, London, 1907. Price 12s. 6d.
- STEVENS, WM. C. — *Plant Anatomy — and hand-book of micro-technic*. 399 pages, 155 illustrations. P. Blakiston's Son & Co., Philadelphia, Pa. 3d edition, 1916. Price \$2.50.
- STITT, E. R. — *Practical Bacteriology — blood work, animal parasitology*. (Full details for the technique.) Plates and text figures. P. Blakiston's Son & Co. Philadelphia, Pa. 4th edition, 1916. Price \$2.00.
- THOMAS, MASON B. and DUDLEY, WM. R. — *A Laboratory Manual of Plant Histology*. 115 pages, 7 text figures, and 15 plates. Crawfordsville, Ind., 1894.
- TRANSACTIONS OF THE AMERICAN MICROSCOPICAL SOCIETY. 1878 + \$3.00 per year. Published by the Secretary of the Society, and hence the place of publication varies.
- WATERHOUSE, J. — *Notes on the Early History of the Camera Obscura*. The Photographic Journal, including the transactions of the Royal Photographic Society of Great Britain, Vol. XXV, May 31, 1901, pp. 270-290. This is the

- best statement of the case found. Many extracts from original sources are given. See also the last edition of the *Encyclopædia Britannica* under *Camera Obscura*, written by General Waterhouse.
- WATERHOUSE, J. — Notes on Early Tele-dioptric Lens-systems, and the Genesis of Telephotography. *The Photographic Journal*, including the transactions of the Royal Photographic Society of Great Britain. Vol. XLII., Jan. 31, 1902, pp. 4-21, one pl. This paper gives a good account of the introduction of the combination of a convex and a concave lense for projection, i.e. the use of an amplifier.
- WATSON, WM. — *A Text-book of Physics*. 4th edition, 927 pages, 579 figures. Longmans, London, 1907.
- WHIPPLE, G. C. — *The Microscopy of Drinking Water*. 3d ed. 409 pages, 20 colored plates. John Wiley & Sons, New York, 1914. Price \$3.50.
- WHITE, ANDREW DICKSON. — *The Warfare of Science with Theology*. 2 vols. D. Appleton & Co., N.Y., 1910. Price \$5.00.
- WINSLOW, CHARLES-EDWARD AMORY. — *Elements of Applied Microscopy*. A text-book for beginners. 183 pages, 60 figures. John Wiley & Sons, New York, 1905. Price, \$1.50.
- WINTON, ANDREW L., in collaboration with DR. J. MOELLER. — *The Microscopy of Vegetable Foods*. 2d edition. 701 pp. Illust. John Wiley & Sons, New York, 1916. Price \$6.50.
- WISTAR INSTITUTE of ANATOMY and BIOLOGY, Woodland Ave. and 36th St., Philadelphia, Penn.: Style Brief giving methods of preparing manuscript for publication; Publishers of scientific journals: *Journal of Morphology*; *Journal of Comparative Neurology*; *American Journal of Anatomy*; *Anatomical Record*; *Journal of Experimental Zoölogy*.
- WRIGHT, SIR A. E. — *Principles of Microscopy*, being a hand-book to The Microscope. 250 pages, 97 text figures, and 18 plates. The MacMillan Company, New York, 1907. Price \$6.50.
- ZAHN, JOANNES. — *Oculus artificialis teledioptricus, sive telescopium nova methodo explicatum ac comprimis è triplici fundamento physico seu naturali, mathematica dioptrico et mechanico, seu practico stabilitum; opus curiosum theoricopracticum magna rerum varietate adornatum*. 2d edition. 50 + 645 + 15 pp. Over 600 fig. *Johannis Christophorilochneri, Norimberga e, 1702*.
- ZEITSCHRIFT FÜR WISSENSCHAFTLICHE MIKROSKOPIE UND FÜR MIKROSKOPISCHE TECHNIK. Illust. Methods, bibliography and original papers. 1884 +. Verlag von S. Hirzel, Leipzig, Germany. Published quarterly. Subscription to foreign countries, 21.60 marks.

INDEX

A

- Aberration, chromatic, 288
correction of, 285, 289, 294
cover-glass and fig. of, 78, 285-286
spherical, 284-285, 288
- Absolute alcohol, 348
index of refraction, 273
- Absorption spectra, 251, 259, 264
- Achromatic condenser, 57-59
objective, 21, 291
- Achromatism, 290, 435
- Achromatization, 290, 435
- Actinic focus, 222
- Adjustable objective, 22, 77, 229
in photo-micrography, 229
- Adjustment of analyzer, 267-269
coarse or rapid; fine, 27, 97
of objective for cover-glass, 77, 229
- Aërial image, 31, 33
- Air bubbles, 80, 112
- Albumen fixative, 348
- Alcohol absolute, 348
ethyl, 348-349
denatured, 349
methyl, 349
mixtures, how to make, 347-348
picric, 363
- Alcoholic dye, 393
- Amici prism, 247
- Amplifier, 139
for projection, 201
- Amplification of microscope, 131
- Analyzer, 264-266
- Angle of aperture, 294
critical, 275
visual and fig., 6, 127, 128-129
- Angström and Stokes law, 252-253
- Angular aperture, 294-296
- Anisotropic objects, 268
- Apertometer, 298
- Aperture, angular and numerical determination of, 297
numerical, 294-297
and diaphragm, 62-63
and opacities, 303-304
table of, 296
- Aplanatic objectives, 21
- Apochromatic condenser, 58
objectives, 291, 437
- Apparatus and material for chapters, 36, 77, 107, 127, 160, 206, 246, 270, 312, 368
- Apparent size of objects, 9
- Appearances, interpretation, 107, 126
- Arc lamp and fig., 72
- Arrangement of minute objects, 336
of serial sections, 404
- Artificial illumination, 48-49
- Autochrome photographic plates, 244-245
- Avoidance of inversion in drawings, 172-176
vibrations in photography, 217-218
- Axial light, 65
experiments with, 65
- Axis, optic, 282-284
of projection microscope, 200-201
secondary, 11, 284

B

- Back combination, 20
- Bacteria, 334-335
- Bacterial cultures, photographing, 213
- Balsam, 339, 350
acid, 351
alkaline or neutral, 350
bottle, 328-329
filtering, 350
mounting in, 329-330

- Balsam, natural, 350
 neutral or alkaline, 350-351
 removal from lenses, 93
 removal from slides, 315
 xylene, 350
- Base of microscope (fig.), 27
- Basket for slides (fig.), 385
- Bench, optical, 221
- Bent-neck bottle or vial, 331
- Bibliography, 35, 76, 126, 159, 205, 245, 269, 311, 367, 422-423, 440, 443
- Binoculars, 82-91, 431-432
 figures of, 84-85, 87, 432
 parallel or diverging tubes, 86
- Black aniline for tables, 365-366
- Blocks for shellvials, 332
- Blood, absorption spectrum of, 259
- Blotting paper for models, 413-422
- Board, reagent, 332, 345
- Borax carmine, 351
- Bottle for balsam, glycerin, or shellac, 328-329
- Box, imbedding and fig., 378
 washing for tissues (fig.), 369
- Brownian movement or pedesis, 118
- Burning point or focus, 284
- C
- Cabinet for microscopic preparations, 340-345
- Calipers, micrometer, 318-319
- Camera, 206
 drawing, 176
 photographic, 206
 photo-micrographic, 217-218
 testing, 212
 vertical, 207-218
 vibrations, avoidance of, 217-218
- Camera lucida, 136-137, 161
 Abbe (fig.), 163-170
 Wollaston's fig. of, 136, 162
- Canada balsam, 329, 350-351
 mounting in, 329-330
 removal from lenses, 93
 removal from slides, 315
- Carbol-turpentine, 352
- Carbol-xylene, 352
- Carbon-monoxide hæmoglobin spectrum, 261
- Card, black-pinhole (fig.), 6, 9, 10
 catalogue, 337
 centering, 326
- Care, of eyes, 94-96
 microscope, mechanical parts, 92
 optical parts, 92-94
 of negatives, 214
 of oil immersions, 82
 of water immersion objectives, 80
- Carmine, borax, 351
 mucic-, 351
 spectrum of, 262
- Castor-xylene clarifier, 391
- Cataloguing formula, 338-339
 preparations, 337
- Cedar-wood oil, 352
 clearing with, 352
 for oil immersion objectives, 438
- Cells for mounting, 324
 staining isolated, 332
- Cement, shellac, 364
- Cementing collodion, 353
- Center, optic or optical, 11, 282
- Centering condensers, 65
 projection apparatus, 201
 source of illumination, 65
- Centering-card, 326
- Central light, 46
- Chamber, moist, 333
- Chloral hæmatoxylin, 359
- Chloroform, 352
- Chromatic aberration, 288
 correction, 290, 435
- Circle, Ramsden's circle, 34, 76
- Clamp for microtome, 378
- Clarifier, castor-xylene, 353
- Class demonstrations, 193, 195
- Cleaning, back lens of objective, 94
 homogeneous immersion objectives, 82
 mixture for glass, 320
 optical parts, 92
 slides and cover-glasses, 315-317
 water immersion objectives, 80
- Clearer, 330, 352
- Clearing mixtures, 352

- Cloudiness of objective and ocular, 109
 removal of cloudiness, 93, 109
- Coarse adjustment of microscope, 27, 97
- Cobweb micrometer, 148
- Collection of microscopic material, 334
- Collodion, 353
 castor-xylene method with, 391
 coating glass rod, 116
 cementing, 353
 clarifying of, 391
 fastening sections to slide, 386
 handling sections with paper, 390
 hardening, 388
 method, 387-392
 method with paraffin, 391-392
 transferring sections from knife to slide, 390
- Collodionizing sections, 353
- Color photography, 244-245
- Color-correct photography, 234-240
- Color images, 80
 law of, 253
 production of by polariscope, 267
 screens, 234-240
 spectral, 248
- Combinations in objectives, 20-21
- Comparing two microscopic fields, 122
- Comparison ocular (fig.), 123
 prism, 249
 spectrum, 253
- Compensation ocular (fig.), 24, 292-294
 434
- Complementary spectra, 253
- Concave lenses, 281, 427
 mirror, use of, 54
- Condensers, 57-76, 297, 434
 Abbe, 59
 achromatic, 57, 59
 apochromatic, 58
 centering, 59-60
 homogeneous immersion, 64, 297
 image of scale for micrometry, 155
 in drawing for models, 419-420
 lighting the field with, 63
 mirror with, 63
 non-achromatic, 58-59
 numerical aperture of, 60
 photo-micrography with, 228-231
 source of light with, 60-61
 standard size, 106
 substage, 57
- Condensing lens for projection, size of,
 233, 420
- Congo glycerin, 354
- Congo red, 354
- Construction of images, 12
 real and virtual images, 13-14
- Continuous spectrum, 248
- Contour, double, 116
- Converging lens, 281, 427
- Convex lens, 281
- Correction, chromatic or color, 288-294
 of the aberration of lenses, 284-294
 cover-glass, 285
 over and under correction, 285-288
- Cotton, collodion, 353
 soluble, 353
- Counterstaining, 395-396
- Cover-glass or covering glass, 313
 aberration, (fig.) 78, 285-286
 adjustment, directions, 78-79, 229
 adjustment for in photo-micrography, 229
 adjustment and tube length, 286-288
 anchoring, 327
 cleaning, 316-318
 correction, 286-288
 effect on rays from object, 40-43, 286
 focusing with and without, 42-43
 for unadjustable objectives, 285-287
 gauges or measures (fig.), 318-320
 measuring the thickness of, 43-45, 318-320
 sealing, 326-327
 thickness, 318-319
 tube-length and cover-thickness, 286-288
 variation in thickness, 319
 wiping, 317-318
 working distance with and fig., 40-43
- Critical angle, 64, 275-276
- Crystals for pedesis, 119
- Currents, diffusion, avoidance, 117, 396

- Cutting sections, free-hand, paraffin, collodion, 374-375, 387
 Cyco photographic paper, 178
 Cylindrical spectacles, 427-428
- D
- Dark-ground condenser or illuminator, 71-73
 illumination, 67-76, 120, 297
 Dark room for drawing and photography, 217, 242
 Daylight, 45
 artificial with curve, 49-53, 203-205
 glass, 50-53
 lantern with, 203-205
 table with, 203-205
 Decalcifier, 354
 Dehydration, 395
 Demonstration, class, 193-205
 lantern and table, 203-205
 projection microscope, 197-203
 Denatured alcohol, 349
 Deparaffining, 384
 Designation of oculars, 23-26
 of wave lengths of light, 256
 Determination of field, 29-30
 magnification, 136, 307
 working distance, 41
 Developing and light for, 241-242, 243
 Diamond for writing, 401
 Diaphragms and their use, 47, 48, 62, 181
 Diatoms, 335-336
 Dichromate cleaning mixture, 320
 Diffraction of light, 280, 300-302
 Diffuser, ground-glass for, 50-53, 181
 Diffusion currents, avoidance, 396
 Direct light, 45
 vision spectroscopie, 249
 Disc, Ramsden's, 34
 Dispersion of light, 280
 Dissecting microscope, 88-90
 spectacles, 87
 Dissociating liquids, 354
 Dissociator, 332, 354
 Formaldehyde, 354
 Müller's fluid, 354
 nitric acid, 354
- Distance, standard for microscopy, 139
 working, 39-40
 Distinct vision, near point, for adults, 130
 Distinctness of outline, 114
 Distortion in drawing, 162
 Diverging lens, 281
 Dividers, measuring spread of, 134
 Double-objective binocular, 83-88
 ocular, 433
 Double vision, 134
 Doubly contoured, 116
 refracting, 268
 Draw-tube, 27, 37
 Drawing, 160-193
 board for camera lucida, 166, 169
 camera lucida, 161-170
 distortion, avoidance of, 162
 erect images in, 172-176
 free-hand, 161
 inversion in, 172-176
 magnification of, 309
 microscopic, 162-174
 models, 416-420
 photographic camera for, 161, 173, 176-178
 projection apparatus for, 161, 183-188
 room for, 242
 scale and enlargement, 170-172
 table and shelf for and fig., 179, 186
 with low and high powers, 186, 187
 with the simple microscope, 188, 190
 Drawings, lettering, 190-191
 on back of photographic prints, 178
 on blue prints, 178
 on a vertical or horizontal drawing board, 185
 reduction for publication, 190
 Dry mounting, 323
 objectives, and aperture, 21, 296-297
 plates, 244
 Drying rack for bottles (fig.), 366
 Dust of living rooms, examination, 123-124
 on objectives and oculars, 34, 109

- Dutch compound microscope (fig.), 420
 Dyes in microscopy, 392-393
- E
- Eikonometer (fig.), 154-155
 micrometry and magnification with,
 154-155
- Elastic stain, 355, 397
- Electric arc lamp, 417-419
 incandescent for projection, 417-420
- Electrification of paraffin ribbons, 381
- Embryos, camera for, 210
 photographing, 209
 serial sections of, 402
- Enlargements of photographs, 232-234
 focusing and printing for, 233
- Eosin, 355-356
 counterstaining with, 395-396
- Eosin-methylene blue, 356, 398
- Equivalent focus, oculars and objectives, 19
- Erect images, 174-176
- Erecting binocular, 88
- Ether-alcohol, 356
 sulphuric, 356
- Ethyl alcohol, 348
- Examination of dust, etc., in rooms, 123-124
- Excluder of light (fig.), 226-227
- Experiments, 15, 28-34, 37-40, 53-56,
 61-70, 77-82, 88-91, 109-125,
 224-231, 258-264, 267-269
 adjustable and immersion objectives, 77-82
 binocular microscopes, 88-91
 compound microscope, 28-34
 dark-ground or field, 67-75
 focusing, 37-40
 interpretation of appearances, 109-125
 lighting, 53-70
 micro-polariscope, 267-269
 micro-spectroscope, 258-264
 mounting, 321
 photo-micrography, 224-231
 simple microscope, 15
- Exposure for photographs, 240-241
 with color screen, 241
- Eye and microscope, 5
 visual acuity, 127
 visual angle, 128
- Eyes, care of, 94-96
 muscæ volitantes in, 122
 unlikeness of the two, 91
- Eye-lens of the ocular, 25, 308-309
- Eye-piece or ocular, 23
 demonstration, 433
 micrometer, 143, 153
 parfocal, 38-39, 309
- Eye-point, 15, 33
 demonstration of, 33
- F
- Farrant's solution, 356
- Field and fig. of, 29, 110
 camera lucida, 161-162
 illumination of, 48, 63, 109-110
 view with microscope, 29
- Field-lens of ocular, 33, 308-309
 dust on, 109
- Filar micrometer ocular, 147-149
- Filtering balsam, 350
- Fine adjustment, 27, 97-98
- Fir, balsam of, 350
- Fixation, 368
- Fixative, albumen, 348
- Fixer, 368
- Flemming's fluid, 356
- Fluid, Müller's, 362
 Zenker's, 366
- Fluorite lens, 11, 292, 436-437
- Focus, 11, 284
 actinic and visual, 222
 appearances with different, 121
 equivalent of objectives and oculars, 19, 27
 depth of and aperture, 303-304
 principal, 11-12, 284
- Focus, real, 12-14
 virtual, 12
 visual and actinic, 222
- Focusing, 15, 36
 adjustments, testing, 97-98
 binocular microscope for the two eyes, 89
 compound microscope, 37-38

- Focusing, effect of cover-glass on, 42-43
 experiments, 36-38
 for printing enlargements, 233-234
 glass, 210-212
 high objectives and low, 37
 in photo-micrography, 224
 screen for photography, 210-211
 simple microscope, 15, 36
 slit of micro-spectroscope, 254
 stand, 210
- Form of objects, determination of, 111
- Formaldehyde, formalin, 356
 dissociator, 354
 isolation with, 332
 percentages, 347
- Formula for aperture, 295
 for cataloguing specimens, 338-339
 for desired percentages, 346
- Fraunhofer lines, 251
- Free-hand sections, 374
- Free working distance, 39-40
- Front combination or lens of objective, 21
- Frontal sections, 407
- Fuchsin, acid, 364
 basic, 355
 picro, 364
- Function of objective, 31, 32
 of ocular, 32
- G
- Gauge for cover-glasses, 318-319
- Gauze absorbent, 315
- Gelatin, 361
- Geometrical construction of images, 12, 281
- Glass cleaning mixture, 320
 ground, 31
 rod, appearance under microscope, 115
 slides or slips, 312-317
 varnish for writing on, 401
- Glasses, graduate, 348
 watch, 249, 259
- Glycerin, 357
 Congo, 354
 mounting objects in, 325
- Glycerin jelly, 357
 for anatomic preparations, 358
 for microscopic preparations, 326-327, 357
- Glycogen, iodine stain for, 359, 398
- Graduate glasses, 348
- Ground-glass focusing screen, 31, 210-211
 preparation of, 31
- Gun cotton, 353
- H
- Hardening collodion, 388
 tissue, 368-369
- Hematin, 359
- Hematoxylin, chloral, 359
 iron, 359
 staining with, 394
- Hemoglobin spectrum, 260
- High School microscope, 99
- Highly refractive, 116
- Histology, physiologic, 340
- History of lenses and microscopes, 424-442
 of photo-micrography, 216
- Holder for magnifier, 17
 for sectioning paraffin, 378
- Homogeneous immersion condenser, 64, 297
 cleaning, 82
 experiments with, 81-82
 history of, 437-438
 liquid, 21, 299-300, 352, 438
 numerical aperture of, 295-296
 objectives, 21, 295, 437
 tester, 299-300
- Hones and honing, 372-373
- Hood for front of objective and fig., 203
- Huygenian ocular, 25-26, 146
 for movable scale micrometer, 146
 for photo-micrography, 221
- I
- Illumination, 45-76
 air and oil, 112-114
 artificial, 54-75
 camera lucida, 163-168
 centering sources of light, 65

- Illumination, dark-ground, 67-76, 120
 daylight, 45, 53
 entire field, 48, 63, 109-110
 micro-polariscope, 267
 micro-spectroscope, 257
 oblique with air and oil, 112-113
 opaque objects, 46, 434-435
 photography, 209
 photo-micrography, 222
 Wollaston's camera lucida, 163, 168
- Illuminator or condenser, 57
- Image, absorption, 235
 aërial, 31, 33
 color, 80
 erect, 34, 174-176
 formed by lenses, 281-284
 geometrical construction of, 12-14
 inverted real of objective, 34
 magnification of real and virtual, 133, 140, 176
 real fig. of, 13-14
 refraction, 80
 retinal, 7, 34
 size and position, 133-139, 176
 swaying, 66
 tracing, 173, 178-181
 virtual, 8, 14, 15, 34, 139-141
- Imbedding, 377-378, 387-392
 double in collodion and paraffin, 391-392
- Immersion, 21, 64, 437
 condenser or illuminator, 64, 297
 fluid or liquid, 21, 299-300, 352, 437-438
 objective, 21, 47, 80, 437-438
- Incandescence or line spectra, 250
- Incident light, 45
- Index of refraction, 272, 295
 absolute and relative, 273-274
 table of substances, 277
- Indicator ocular, 102, 195, 433
- Infiltration, 376, 387
 collodion, 387-388
 dish and oven, 377
 double with collodion and paraffin, 391-392
 paraffin, 376-384
- Infusions and infusoria, 335
 infusoria for dark-ground illumination, 70
- Initial or independent magnification, 19, 395
- Ink for labels, etc., 339-340
- Interpretation of appearances, 107
 dark-ground illumination to aid, 120
 summary for, 125
- Inversion of the image, 124
- Inversion in drawing, avoidance of, 172, 176
- Invisible and visible radiation, 246-247
- Iodin in alcohol, 361
 for removing mercuric chlorid, 361-362
 stain for glycogen, 359, 398
- Iris diaphragm, 47
- Isochromatic plates, 235
- Isolation, 330
 formaldehyde, 332
 nitric acid, 333
- Isotropic objects, 267
- J
- Japanese filter (lens) paper, 93
- Jar for slides, 360, 363, 385
- Jelly, glycerin, 357
- Jena glass, 437
- Jurisprudence, micrometry in, 157, 159
- K
- Kerosene lamp, 61
- Knife, sharpening of, 372
 support, 380
- L
- Labels and catalogues, 337
- Labeling microscopic preparations, 337-338
 photographic negatives, 214
 serial sections, 410
- Laboratory compound microscope table, 55, 95
 desk, 96
 lockers, 345
- Lagrange disc or circle, 34

- Lamp, alcohol or spirit, 382
 arc, fig. of, 72-74
 black for ingestion, 361
 electric, 62
 kerosene and mazda, 61, 74
- Lantern, for daylight glass and fig., 51
 slides, 182-183
- Lateral swaying of image, 66
- Law of color, 253
- Lens, 10, 280-286
 aberration of, 284-285
 converging, 281
 convex, 281
 eye, 25, 433
 field, 33
 fluorite, 292, 424, 429
 focus on both sides and fig. 12
 history of, 424-429
 holder and fig., 17
 images formed by and fig., 280-284
 paper, bibulous paper, 93
 spherical, 281-283
- Lettering oculars, 26
- Letters or figures, mounted, 31
 for drawings, 190-193
 in stairs, 110
 white for black back-ground, 192
- Light, and lighting, artificial, 48-49
 artificial daylight, 49-53, 65
 axial, 46, 65
 central, 46
 dark-ground, 67
 daylight, 45
 direct and central, 45-46
 direct, 45
 electric, 49, 74, 184, 204, 230-231,
 418-419
 excluder for camera and micro-
 scope (fig.), 226-227
 experiments, 54
 for developing photographs, 241-
 242
 for photography and photo-microg-
 raphy, 209, 222, 228
 incident, 45
 micro-polariscope, 267
 micro-spectroscope, 256
 mirror with, 53-54
 oblique, 47
 polarized light, 264-270
 reflected, 45, 272
 sunlight, 45
 transmitted light, 46
 wave length of, 270
 with kerosene lamp, 54
- Line spectrum, 250
- Lintless towels, 315
- Liquids, currents in, 117
 gelatin, 361
 homogeneous, 438
- Locker, laboratory or student, 345
- Longisections, 399
- M
- Magnification, 131, 136
 compensation oculars, 306-308
 determination of, 136
 effect of adjusting objective on, 144,
 157
 eikonometer for, 154, 155
 expressed in diameters or times
 linear, 131
 initial or independent, 19, 305
 of compound microscope, 4, 46, 132
 of objective, 19, 305
 of photo-micrographs, 228
 of projection apparatus, 170, 208,
 228
 of real images, 133
 of simple microscope, 133-140
 of virtual images, 135
 relation of object and principal
 focus, 140-142
 table of, 143
 varying with compound micro-
 scope, 139
 velocity and, 117
- Magnifier, 7, 16
 tripod, 16
- Marker for preparations, 100-102
- Marking negatives, 214
 objects, 197
 preparations, 100-101
- Masks for preparations, 199-200
- Mazda gas-filled lamp, 55, 74
- Measurer for cover-glasses, 318, 319

- Measuring thickness of slides and covers, 319-320
spread of dividers, 134
- Mechanical parts of compound microscope, 27, 99
care of, 92
- Mechanical stage, 102
- Mercuric chlorid, 362
crystals, 361-362
- Methemoglobin spectrum, 261
- Method, collodion, 387
paraffin, 375
- Methyl alcohol, 349
- Methylated spirits, 349
- Methylene blue, 356
alkaline, 362
and eosin, 356, 398
- Micrometer, 135, 143
arrangement of ocular and stage, 145, 158
calipers, 318
cobweb, 148
filar, 147-149
filling lines of, 136
net, 110, 156
object or objective, 135
ocular and stage, 135
ocular or eye-piece, 143-153
ocular, valuation of, 143-145
ocular, varying the valuation of, 144, 157
photo-micrography and, 228
screw ocular, 146
stage and ocular (fig.), 135, 136
table of magnification, 143
- Micrometry, 146-159
adjustable objectives in, 139, 144, 157
comparison of methods, 153-157
compound microscope, 150, 159
condenser, image of scale, 155
eikonometer, eiconometer, 149, 154-155
in jurisprudence, 157-159
limit of accuracy, 158
ocular micrometer, 152
remarks on, 157-159
simple microscope, 149
- Micrometry, unit of measure in (μ), 150
- Micro-millimeter, 150
micron (μ), mikron, 150
- Micro-photograph, photo-micrograph, 215
- Micro-polariscope, 264-269
experiments with, 267-269
- Micro-projection, 184, 189, 197
drawing with, 184, 189
magnification of, 170
masks for specimens in, 199-200
- Microscope, 4-6, 429, 430
amplification of, 131
binocular, 82-91, 431-433
care of, 92-94
double objective, 83, 88
Dutch, 429-430
erecting, 88
experiments with, 88-89, 91
field, 29-30
fig. of field, 84-85, 87
focusing, 15, 36, 37-38, 42-43, 89, 224
history of, 428-439
magnification, 131
photo-micrography with, 217-231
polarizing, 264-269
projection, and history, 197, 438-439
simple, 7, 133-140
stand for embryos, 210
solar, 198
traveling, 195
- Microscope, compound, 7, 16
cost of, 100
drawing with, 170-172
Dutch and Keplerian forms, 429-430
high-school, 99-100
history of, 429-439
laboratory, 99-100
magnification with, 131
mechanical parts, 27, 99
micrometry with, 150-159
optical parts, 16-27
quality and cost, 99
testing, 97-99
varying magnification of, 139, 157
working distance, 39

- Microscopes for two or more observers,
432-433
- Microscope, simple, 7
drawing with, 160-172
experiments with, 15
focusing, 36
images with, 7, 9
magnification of, 133
micrometry with, 149
mounting of, 16-17
working distance, 39
- Microscope-telescope, 430
- Microscopic objectives, 17
objects, drawing, 160, 193
photography, 214-224
slides or slips, 313
tube-length, 27, 79, 286-287
- Microscopic preparations, cabinet for,
342
cataloguing and labeling, 337-340
mounting, 321
trays for, 343-345
- Micro-spectroscope, 246-264
adjusting, 253
Amici prism for, 247
Angström scale for, 248, 255
direct vision, 249
experiments with, 258
focusing the slit, 254
in photo-micrography, 239
lighting, 257
material needed, 258
objectives to use, 257
reversal of colors, 248
slit mechanism, 253-255
- Microtomes, 370-371
knives for, 372, 380
- Micron, micron (μ), 150
- Mikron, micron (μ), 150
- Milk-globules to overcome pedesis of,
118
- Minerals, absorption spectra, 263
- Minute objects, arranging, 336
- Mirror, 434
arrangement for drawing, 165-185
central and oblique light with, 56
concave, use of, 54
dark-ground illumination, 68, 74
parabolic of Descartes, 434
plane, use of, 54
- Models, 410-423
blotting paper for, 413-416
dissectable, 422
drawings for, 416-420
size of, 414-415
thickness of plates for, 414-416
wax for, 412-413
- Moist chamber, 333
- Molecular movement or pedesis, 118
- Monazite sand, spectrum of, 263
- Mounting, 321-337
cells, preparation of, 324
media and preparation, 350, 356-357
objects for polariscope, 267
permanent, 322
temporary, 321
- Mounting in balsam, 321
dry or in air, 323
in glycerin and glycerin jelly, 326-327
in media miscible with water, 325
in resinous media after drying, 328
in resinous media by successive displacements, 329-330
- Movement, Brownian or molecular, 118
- Muci-carmine, 396
- Müller's fluid, 362
dissociator, 354
- Musca volitantes, 122
- Muscular fibers, isolation of, 333
- N
- Natural balsam, 350
- Negative oculars, 23
- Negatives, photographic, 177
opaquing, 182
storing and labeling, 214, 232
- Net micrometer, 110, 156
- Neutral balsam, 350
red, 362
- Nicol prism, 264-265
Nitric acid, 362
dissociator, 362-363
- Nomenclature of objectives, 19-23
- Non-achromatic condenser, 58-59

- Non-adjustable objectives, 77
 thickness of cover-glasses for, 286-287
- Normal liquid, 363
 salt or saline solution, 363
- Nose-piece, revolving, 28-29
- Numerical aperture and table, 294-297
- O
- Object, determination of form, 111
 image, relative size of, 138-139
 micrometer, 135
 mounting, 321
 printing image of direct, 234
 suitable for photo-micrography, 223
- Objective, 19
 achromatic, 21, 291, 436
 adjustable, 22, 157, 285-287
 adjustment, 77, 157, 229
 aerial image, 31, 33
 aperture, 294, 297
 aplanatic, 21
 apochromatic, 22, 291, 437
 back combination of, 21
 cleaning, 92-93
 cloudiness or dust on, 34
 collar, graduated, 79
 designation or nomenclature, 19-23
 dry, 21
 equivalent focus of, 19, 27
 field of, 29
 focusing for micro-spectroscope, 258
 front combination, 21
 function of in the microscope, 31-32
 homogeneous immersion and cleaning, 21, 82
 experiments with, 81-82
 immersion, 21
 initial magnification, 19, 305
 inverted, real image by, 34
 low and high, 20-23
 magnification of, 19, 131, 305
 micro-polariscope, 267
 microscopic, 19-23
 micro-spectroscope, 257
 names of parts, 21
 nomenclature or designation of, 19-23
- non-adjustable, unadjustable, 22, 157, 285-287
 nose-piece for, 28-29
 numbering or lettering, 19
 numerical aperture, 294-297
 oil immersion, 21, 295, 438
 panchromatic, 22
 para-chromatic, 22
 parfocal, 38-39
 photo-micrographic, 220-222
 projection, 201
 screw-thread for, 103-106
 semi-apochromatic, 22
 table of field, 29-30
 terminology or designation, 19-23
 unadjustable, non-adjustable, 22, 157, 285-287
 variable, 22
 visual and actinic foci in, 222
 water immersion, 21, 80
 working distance, 39-40
- Oblique light, 47, 65-67
- Oculars, various forms of, 23
 cloudiness or dust on, 93, 109
 comparison and fig., 123
 compensation, 24, 26, 292-293
 concave or amplifier, 429-434
 designation or nomenclature of, 23-26
 equivalent focus, 27
 eye-point of, 15-33
 field-lens, 25, 308-309
 filar or screw micrometer, 147-149
 for two observers, 433
 function of, 32
 Huygenian (fig.), 6, 25-26, 146-147
 indicator or pointer, 102, 195
 lettering and numbering, 26
 magnification of, 27, 308-309
 micrometer and micrometry, 143-153
 negative, 23
 parfocal, 38, 309
 photo-micrography, 220-222, 231
 pointer or indicator, 102, 195
 positive, 23
 power or magnification of, 26-27
 projection, 201, 226

- Oculars, Ramsden's and fig., 24-25
 spectroscopic, 247
 standard sizes, 106
- Oil and air, distinguishing, 113-114
 cedar-wood, 352
- Oil-globules, study of, 113
- Oil immersion objectives, 21, 205, 437
- Opacities and aperture, 303-304
- Opaque objects, lighting, 46, 434-435
- Opauing negatives, 182
- Opera glasses, 430
- Optic axis, 282-284
- Optical bench, 221
 center, 11, 282
 parts of compound microscope, 16-27
 section, 117
- Optics of the microscope, 270-311
- Order of procedure in mounting, 323-329
 in air or dry, 323
 in balsam, 328-329
 in glycerin and glycerin jelly, 326-327
- Ordinary ray with polarizer, 264
- Organs and tissues, preparation of, 368
- Orthochromatic plates, 235
- Outlines, distinctness of, 114
- Oven for paraffin infiltration, 377
- Over-correction, 285-288
- Oxy-hemoglobin spectrum, 260
- P
- Panchromatic photographic plates, 235
- Paper, bibulous (lens paper), 93
 blotting for models, 413-422
 photographic for prints, 178, 181, 232, 234
- Paraffin, 363, 375-386
 deparaffining, 384
 filtering, 363
 infiltrating with, 376-377
 imbedding in, 377
 imbedding in paraffin and collodion, 391-392
 method for sectioning, 375, 386
 oven for infiltrating, 376
 removing from sections, 384
 sections, spreading, 382-384
 wax, 363
- Parfocal objectives and oculars, 38-39, 399
- Parfocalization, 38-39, 310
- Pedesis or Brownian movement, 118
 overcoming, 118
 with polariscope, 119
- Penetration of objectives, 302-304
- Percentage of liquids and solutions, 346
- Permanent mounting, 322-332
- Permanganate of potash, spectrum, 252, 259
- Photo-engraving, drawing and lettering for, 187-193
- Photographic camera, 206, 210
 enlargements, 233
 magnification rod for, 208-210
 negatives, 177
 objectives, 178-180
 prints, 178, 181, 232, 234
- Photography, 206-245
 avoidance of distortion in, 207-208
 avoidance of vibration, 219
 bacterial cultures, 213
 color correct, 234-240
 embryos, 209-212
 focusing, 210-211, 224
 for making figures, 176-182
 indebtedness to photo-micrography, 216
 lighting for, 209
 living objects, 207
 objects in liquids, 207
 plates, panchromatic and spectrum, 235, 236-237
 scale of magnification or reduction of photographs, 208
 vertical for (fig.), 207, 210, 218
 scale of magnification or reduction of photographs, 208
 vertical for (fig.), 207, 210, 218
- Photo-micrograph, 214-215
 color screen with, 244
 determination of magnification in, 208, 228
 experiments at 20,
 to 2000 diameters, 225-228

- Photo-micrograph, plates for, 244
with and without an ocular, 230-231
- Photo-micrographic camera, 217-220
- Photo-micrography, 214, 245
apparatus, 217
camera for, 217-219
compared with ordinary photography, 216
condenser for, 228-231
cover-glass correction in, 220
distinguished from micro-photography, 215
experiments with, 225-231
exposure for, 240
focusing, 224
focusing screen, 210-211
lighting for, 222-228, 240
mechanical stage in, 220
microscope for, 220
micrometer for magnification in, 208, 228
objectives and oculars for, 220-221
three ways of bringing out details, 224
vertical camera for, 217-218
with and without oculars, 226
- Physiologic histology, 340
- Picric-alcohol, 363
- Picro-fuchsin, 364
- Pillar of the microscope, 27
pin-hole card and fig., 9
- Pipette, 334
for eggs and specimens, 334
- Plane mirror, use of, 54
plates, dry, isochromatic, pan-chromatic, spectrum, 235-237, 244
- Pleochroism, 268
- Pleurosigma angulatum, 65, 78
- Point, burning, 284
eye, 15, 33
- Pointer or indicator ocular, 102, 195
- Polariscope and lighting for, 264-269
objects to use for, 266
objectives for, 266
- Polarized light, ordinary and extraordinary ray, 264
- Polarizer and analyzer, 264
- Polarizing microscope, 264-269
pedesis or Brownian movement with, 119, 268
- Position of objects or parts, 109-110
- Positive oculars, 23
- Power, of microscope, 131
of objective, 19, 305
of ocular, 308
- Preparation, of reagents, 346-366
of tissues and organs, 368
- Preparations, cataloguing and labeling, 338-339
cabinet for, 340-345
marked or masked for projection, 199-200
permanent and temporary, 321
- Principal focus, 11, 284
optic axis, 11, 282, 284
- Prints, photographic for drawings, etc., 178, 181, 234
- Prism, Amici, 247
camera lucida, 162-166
comparison in spectroscope, 249
for drawing with projection, 185
Nicol of polariscope, 265
- Projection microscope, 2, 9, 184-189, 197-203
history of, 438-439
objectives for, 201
vertical microscope with, 203
wiring for and fig., 202
- Pupil of lens, eye-point, 34
- Pupillary distance in binoculars, 91
- R
- Ramsden's circle, eye-point, 34
ocular, 24-25
- Ray filter or color screen, 237
compensating and contrast, 238
- Razor for sections and support, 380
- Reagent board for bottles, 345
- Reagents for microscopy, 346-367
preparation of, 346-367
- Real image, 13, 34, 133-139, 176
- Radiation, visible and invisible (fig.), 246, 247, 271

- Record tables, 232, 337-339, 386, 391
 collodion method, 391
 negatives, 232
 paraffin method, 386
- Red, Congo, 354
 neutral, 362
- Reflected light, 271
- Reflection, irregular and regular, 272
 total internal, 275
- Refraction (fig.), 11, 272, 273-280
 air to glass and water, 273-274
 index of, 272
 law of sines in, 272
 medium in front of objective, 42
 relative and absolute index, 274
- Refractive, doubly, 268
 highly, 116
 singly, 267
- Relative position in microscopic objects, 109
 index of refraction, 274
 of object and image, 14
- Resinous media, mounting in, 328
- Resolution (eye and microscope), 127, 129, 297
- Resolving power, 297
- Retinal image, 5, 7, 9, 130
- Revolving nose-piece (fig.), 28
- Ribbon sections, 379-386
 deparaffining, 384
 drying, 383
 electrification, 381
 spreading, 382
 storing, 381
 tray for, 342-344
 winder, 382
- Room, dark and drawing (fig.), 217, 242
- Royal Microscopical Society standards, 103-106
- Rule of thumb method, 1, 3
- S
- Sagittal sections, 409
- Salt solution, normal, 363
- Scale, of drawing, 309
 size of photographs, 208
 wave length, 248, 250, 255
- Scalpels (fig.), 379
- Screen, color, 234-240
 focusing for photography, 210-211
- Screw for objectives, R. M. S., 103
- Sealing cover-glass, 325-327
- Secondary axis (optic), 11
- Section knife and sharpening, 372
 lifter (fig.), 389
 optical, 117
- Sections, arrangement on the slide, 400, 404
 clearing, 330
 collodionizing, 387-392
 cutting, 374-381
 dehydration, 229
 deparaffining, 384
 drying, 383
 extending with water, 382
 fastening to slide, 405
 free-hand, 374
 freezing, 374
 frontal, 407
 longisections, 399
 mounting, 405
 paraffin, 375-386
 ribbon, 379-383
 sagittal, 409
 serial, 399-410
 spreading or stretching, 382-383
 spreading plates for (fig.), 382-384
 staining, 392-395, 402
 surface sections, 400
 thickness of, 404
 transections, 399
 transferring (collodion), 390
 vertical, 400
- Serial sections and fig., 399-410
 arrangement on the slide, 400-404
 cross or transections, 406-407
 embryos, 402
 fastening to the slide, 405
 frontal, 407
 imbedding for, 406-410
 labeling, 410
 mounting on slides, 405
 models from, 410-423
 numbering slides of, 400-401
 order of sections, 400-404

- Serial sections, orienting objects for,
 403
 removal of mercury from, 401
 size of slides for, 405
 spreading on water, 382
 staining, 392-395
 thickness of 404
 transections or cross sections, 406-
 407
 transferring collodion sections, 370
- Sharpening section knives, 372-373
- Shellvials, 331
- Shellac cement, 364
- Silver staining of tissues, 365
- Simple microscope, 7
- Sines, natural, Insert and, 272-279
- Single-objective binocular, 83-88
- Slides or slips for specimens (fig.), 312-
 317
 cleaning, 314-317
 thickness for dark-ground illumina-
 tion, 314
- Slide-basket, 385
- Slide-tray, 199, 342-344
- Slit mechanism of micro-spectroscope,
 254
- Society screw for objectives, 103
- Sodium lines and spectrum, 252-255
- Solar microscope, 198
- Solar spectrum, 250, 252
- Soluble cotton, 353
- Solutions, 346-356
 Farrant's, 356
 how to prepare, 346-347
 percentages, how to get, 346
 saturated, 346
- Spectacles, concave and convex, dis-
 secting, 10, 87, 427-428,
 cylindrical for astigmatism, 427-
 428
 history of, 427
- Spectroscope, 247
 direct vision, 249
 examination of color screens with,
 239
- Spectrum, 250-251
 absorption, 250-264
 Angström and Stokes law, 252
 banded, 250
 blood, arterial and venous, 259
 carbon monoxide hemoglobin, 261
 carmine solution, 262
 color screens, 239
 colored bodies without bands, 262
 colorless bodies, 262
 comparison or double, 255
 complementary, 253
 continuous, 248
 daylight or sunlight, 250
 double or comparison, 255
 hemoglobin, 260
 incandescence or line, 250
 methemoglobin, 252
 minerals, monazite, etc., 263
 normal and prismatic (fig.), 247,
 250
 oxyhemoglobin, 260-261
 permanganate of potash, 252, 259
 prismatic and normal (fig.), 247,
 250
 sodium, 252
 solar or daylight, 252
- Spherical aberration, 284-285
- Stage, mechanical, 27, 102
- Stain, alcoholic and aqueous, 393
 acid and basic, 393-394
 aqueous and alcoholic, 393
 combined, 397
 counter, 392, 395-396
 differential, 392
 elastic, 355
 general, 392
 multiple, 397
 nuclear, 392
- Staining, 332, 392-402
 in toto, 351
- Stand, microscopic, 27, 97-100
 focusing for embryos, 210
- Standard distance for magnification,
 130, 139
- Standards, R. M. S., for objectives, 103-
 106
 condensers, 106
 oculars, 106
- Starch, determination of, by polarized
 light, 268

- Stoke's and Angström's law for absorption spectra, 252-253
- Storing negatives, 214
preparations, 340-345
ribbon sections, 381
- Strops and stropping for section knives, 372
- Student or laboratory locker, 345
- Style brief, Wistar Institute's, 188
- Substage, 27, 188
condenser, 57
- Sudan III for fat staining, 365
- Sulphonal with polariscope, 269
- Sulphuric or sulfuric acid, ether, 320, 356
- Support of microtome knife, 380
- Surface sections, 400
- Swaying of image, 66
- Systems of objective, front, middle, and back, 20-21
- T
- Table, black for, 365
laboratory or student, 55, 95-96
projection and drawing, 179, 186
- Tables, aperture of objectives, 296
collodion method, 391
immersion liquids, 301
magnification and ocular micrometer valuation, 143
negative record, 232
paraffin method, 386
refractive indices, 277
size of field, 30
- Temporary mounting, 321
- Tester for homogeneous liquids, 299-301
- Testing a camera, 212
a microscope and its parts, 97
- Thickness of cover-glasses for non-adjustable objectives, 285-286
for serial sections, 404
- Tissues, fixing, etc., 368
washing apparatus for, 369
- Towels, lintless, 315
- Tracing images for drawings, 173, 178, 181
- Transections or cross sections, 406
- Transferring collodion sections, 390
- Transmitted light, 46
- Tray for ribbons and slides, 199, 342-344
- Tripod magnifier, 16, 211
- Tube of microscope, 47
- Tube-length (fig.), 47, 79, 286-287
cover-glass adjustment by, 287
- Turn-table (fig.), 324
- U
- Ultramicroscopy, 75
- Unadjustable objectives and covers for, 285-286
- Under-correction, 285, 288
- Unit of measure in microscopy (μ), 150
wave length of light, 256
- V
- Valuation of ocular micrometer, 144-148
- Varnish for writing on glass, 401
- Varying magnification in compound microscope, 139, 157
ocular micrometer valuation, 144, 157
- Velocity of light and sine law, 277
under the microscope, 117
- Velox printing paper, 178
- Vertical camera (fig.), 210
microscope, projection with, 203
sections, 400
- Vials, straight and bent-neck, 331
block with holes for, 332
- Vibrations, avoidance in photography, 217-218
- Virtual focus, 12
image, 8, 9, 15, 133
standard distance at which measured, 139
- Visible and invisible radiation, 246-247
- Visibility, 127, 234
- Vision, double, 134
standard for adults, 130
- Visual angle (fig.), 6, 9, 127-129
focus, 222
necessary for resolution, 127-129
- W
- Washing apparatus for tissues, 369
- Watch glasses, 349, 359

- Water immersion objectives, 21, 80, 296
Wave lengths, designation, 255-256
scale of, 255
Wax models, 412-413
paraffin, 363, 375-386
Wenham's binocular microscope, 84
Wire gauze experiment with, 122
Wiring for arc lamp, 202
Wistar Institute Style Brief and journals, 188-190
Wollaston's camera lucida, 162
Work-room for drawing and photomicrography, 217
Working distance (fig.), 40-43
free, 39-40
Writing diamond, 401

X
Xylene, 350
balsam, 350
Xylol, xylene, 350

Z
Zenker's fluid, 366

INDEX OF PROPER NAMES

[SEE ALSO BIBLIOGRAPHY AND COLLATERAL READINGS.]

- Abbe, 309-310, 434-435, 437, 440
Adams, 439-440
Airy, 428, 440
Alhazen, 426, 440
Alling, 340
Amici, 437
Archer and Diamond, 216
Atkinson, 213
- Bacon, Francis, 439
Bacon, Roger, 426-428, 440
Baker, 439-440
Barbaro, 427, 438-440
Barnard, 84
Bausch, E., 103
Bausch & Lomb Optical Company,
19, 123, 287, 372, 440
Beale, 2, 123, 124, 126
Beck, 86-87, 126
Bernard, Claude, 367
Black, 247
Bleile, 259
Bock, 427, 440
Bool, 344
Borellus, 441
Born, 413
Bousfield, 216
Boyer, 336
Brewster, 57, 60, 202, 435-437, 441
Brown, A. J., 53
Brown, R., 126
Brown & Sharpe, 318
Brookover, 423
Burch, 439
Burr, 423
- Caldwell, 320
Carpenter-Dallinger, 7, 58, 108, 207,
427
- Cesi, 7
Chamot, 67, 71, 75-76, 116, 124, 157-
158, 264, 277, 313
Cherubin d'Orleans, 83, 431
Comstock, 331
Cox, 3, 437
Cramer Dry Plate Co., 245
Cunningham, 337
- Daniell, 253
Descartes, 272, 434
Dippel, 297, 439
Dixon, 381
Dolland, 436
Donné et Foucault, 216
Dudley and Thomas, 367
Durand, 88
Dwight, 414
- Eastman Kodak Co., 245
Edinger, 433
Emerton, 414
Ewell, 158-159
- Faber, 7
Fish, 366
Freeborn, 352, 359
- Gage, H. P., 53, 205, 244
Gage, S. P., 339, 343, 365, 413, 422
Galileo, 7
Gagee and McMunn, 260
Gordon, 60, 75-76
Goring and Pritchard, 439
Greenman, 343
Griffith, 337
Gundlach Optical Co., 300
- Hardesty and Lee, 205
Harting, 150, 424, 427, 432-433

- Hathaway, 423
 Hertzfel, 434
 Hitchcock, 364
 Hodge, 340
 Hooke, 127, 129, 434, 438-439
 Howell, 130
 Huygens, 441

 Ives, F. E., 85, 86, 432
 Ives, H. E., 52

 Jansen, 430
 Jevons, 126
 Johnston, 423

 Kingsbury, 204, 376, 383, 403, 413
 Kepler, 430, 431, 438-439

 Leitz, 433
 Lincei, Academy of, 7
 Listing, 150

 McClung, 379, 382
 Maddox, 216
 Mall, 413
 Mark, 413
 Mees, 245
 Mercer, 216, 311
 Minot, 340, 371
 Moitessier, 219
 Moore, 96

 Nacet, 432
 Needham and Lloyd, 367
 Nelson, 66, 435
 Newcomer, 337
 Newton, 442
 Nichols, 248

 Orndorff, 353

 Pansier, 427
 Pennock, 38, 309, 319
 Pholman, 413
 Piersol, 169
 Pillsbury, 166
 Powell and Lealand, 58
 Ptolemæus, 426-427

 Queen & Co., 309

 Ramsden, 433
 Richardson, 158
 Riddell, 83, 432
 Riddle, 365
 Risner, 426
 Robin, 433
 Rogers, 158-159
 Rumsey, 209
 Rutherford, 126

 Schaeffer, 423
 Scheiner, 431, 438-439
 Schott, 437
 Seneca, 425
 Selligie, 436
 Shadboldt, 216
 Shedd, 311
 Smith, H. L., 299-300, 337
 Smith, G. M., 371
 Snell, 272
 Spencer, C. A., 292, 436
 Spencer Lens Co., 19, 89, 287, 372, 433
 Spitta, 292-293, 297
 Starr, 215
 Sternberg, 216

 Tolles, 83, 437-438

 Walgensten, 438
 Walton, 439
 Ward, 340
 Watson, 58, 278
 Wedgwood and Davy, 216
 Wenham, 78, 83-84, 432
 White, A. C., 424
 Wilson, 215
 Winslow, 35
 Wollaston, 439
 Woodward, 215
 Wright, Sir A. E., 3, 34, 61, 81, 92, 122,
 159, 301-304, 393
 Wright, Lewis, 291

 Young, 428

 Zahn, 438
 Zeiss, 19, 59, 432, 437

TABLE OF NATURAL SINES

Compiled from Prof. G. W. Jones' Logarithmic Tables

MINUTES	DEGREES AND QUARTER DEGREES UP TO 90°											
1'0.00029	1°	0.01745	16°,	0.27564	31°,	0.51504	46°,	0.71934	61°,	0.87462	76°,	0.97030
2 0.00058	1°,15'	0.02181	16°,15'	0.27983	31°,15'	0.51877	46°,15'	0.72236	61°,15'	0.87673	76°,15'	0.97134
3 0.00087	1,30	0.02618	16,30	0.28402	31,30	0.52250	46,30	0.72537	61,30	0.87882	76,30	0.97237
4 0.00116	1,45	0.03054	16,45	0.28820	31,45	0.52621	46,45	0.72837	61,45	0.88089	76,45	0.97338
5 0.00145	2	0.03490	17	0.29237	32	0.52992	47	0.73135	62	0.88295	77	0.97437
6 0.00175	2,15	0.03926	17,15	0.29654	32,15	0.53361	47,15	0.73432	62,15	0.88499	77,15	0.97534
7 0.00204	2,30	0.04362	17,30	0.30071	32,30	0.53730	47,30	0.73728	62,30	0.88701	77,30	0.97630
8 0.00233	2,45	0.04798	17,45	0.30486	32,45	0.54097	47,45	0.74022	62,45	0.88902	77,45	0.97723
9 0.00262	3	0.05234	18	0.30902	33	0.54464	48	0.74314	63	0.89101	78	0.97815
10 0.00291	3,15	0.05669	18,15	0.31316	33,15	0.54829	48,15	0.74606	63,15	0.89298	78,15	0.97905
11 0.00320	3,30	0.06105	18,30	0.31730	33,30	0.55194	48,30	0.74896	63,30	0.89493	78,30	0.97992
12 0.00349	3,45	0.06540	18,45	0.32144	33,45	0.55557	48,45	0.75184	63,45	0.89687	78,45	0.98079
13 0.00378	4	0.06976	19	0.32557	34	0.55919	49	0.75471	64	0.89879	79	0.98163
14 0.00407	4,15	0.07411	19,15	0.32969	34,15	0.56280	49,15	0.75756	64,15	0.90070	79,15	0.98245
15 0.00436	4,30	0.07846	19,30	0.33381	34,30	0.56641	49,30	0.76041	64,30	0.90259	79,30	0.98325
16 0.00465	4,45	0.08281	19,45	0.33792	34,45	0.57000	49,45	0.76323	64,45	0.90446	79,45	0.98404
17 0.00495	5	0.08716	20	0.34202	35	0.57358	50	0.76604	65	0.90631	80	0.98481
18 0.00524	5,15	0.09150	20,15	0.34612	35,15	0.57715	50,15	0.76884	65,15	0.90814	80,15	0.98556
19 0.00553	5,30	0.09585	20,30	0.35021	35,30	0.58070	50,30	0.77162	65,30	0.90996	80,30	0.98629
20 0.00582	5,45	0.10019	20,45	0.35429	35,45	0.58425	50,45	0.77439	65,45	0.91176	80,45	0.98700
21 0.00611	6	0.10453	21	0.35837	36	0.58779	51	0.77715	66	0.91355	81	0.98769
22 0.00640	6,15	0.10887	21,15	0.36244	36,15	0.59131	51,15	0.77988	66,15	0.91531	81,15	0.98836
23 0.00669	6,30	0.11320	21,30	0.36650	36,30	0.59482	51,30	0.78261	66,30	0.91706	81,30	0.98902
24 0.00698	6,45	0.11754	21,45	0.37056	36,45	0.59832	51,45	0.78532	66,45	0.91879	81,45	0.98965
25 0.00727	7	0.12187	22	0.37461	37	0.60182	52	0.78801	67	0.92050	82	0.99027
26 0.00756	7,15	0.12620	22,15	0.37865	37,15	0.60529	52,15	0.79069	67,15	0.92220	82,15	0.99087
27 0.00785	7,30	0.13053	22,30	0.38268	37,30	0.60876	52,30	0.79335	67,30	0.92388	82,30	0.99144
28 0.00814	7,45	0.13485	22,45	0.38671	37,45	0.61222	52,45	0.79600	67,45	0.92554	82,45	0.99200
29 0.00844	8	0.13917	23	0.39073	38	0.61566	53	0.79864	68	0.92718	83	0.99255
30 0.00873	8,15	0.14349	23,15	0.39474	38,15	0.61909	53,15	0.80125	68,15	0.92881	83,15	0.99307
31 0.00902	8,30	0.14781	23,30	0.39875	38,30	0.62251	53,30	0.80386	68,30	0.93042	83,30	0.99357
32 0.00931	8,45	0.15212	23,45	0.40275	38,45	0.62592	53,45	0.80644	68,45	0.93201	83,45	0.99406
33 0.00960	9	0.15643	24	0.40674	39	0.62932	54	0.80902	69	0.93358	84	0.99452
34 0.00989	9,15	0.16074	24,15	0.41072	39,15	0.63271	54,15	0.81157	69,15	0.93514	84,15	0.99497
35 0.01018	9,30	0.16505	24,30	0.41469	39,30	0.63608	54,30	0.81412	69,30	0.93667	84,30	0.99540
36 0.01047	9,45	0.16935	24,45	0.41866	39,45	0.63944	54,45	0.81664	69,45	0.93819	84,45	0.99580
37 0.01076	10	0.17365	25	0.42262	40	0.64279	55	0.81915	70	0.93969	85	0.99619
38 0.01105	10,15	0.17794	25,15	0.42657	40,15	0.64612	55,15	0.82165	70,15	0.94118	85,15	0.99657
39 0.01134	10,30	0.18224	25,30	0.43051	40,30	0.64945	55,30	0.82413	70,30	0.94264	85,30	0.99692
40 0.01164	10,45	0.18652	25,45	0.43445	40,45	0.65276	55,45	0.82659	70,45	0.94409	85,45	0.99725
41 0.01193	11	0.19081	26	0.43837	41	0.65606	56	0.82904	71	0.94552	86	0.99756
42 0.01222	11,15	0.19509	26,15	0.44229	41,15	0.65935	56,15	0.83147	71,15	0.94693	86,15	0.99786
43 0.01251	11,30	0.19937	26,30	0.44620	41,30	0.66262	56,30	0.83389	71,30	0.94832	86,30	0.99813
44 0.01280	11,45	0.20364	26,45	0.45010	41,45	0.66588	56,45	0.83629	71,45	0.94970	86,45	0.99839
45 0.01309	12	0.20791	27	0.45399	42	0.66913	57	0.83867	72	0.95106	87	0.99863
46 0.01338	12,15	0.21218	27,15	0.45787	42,15	0.67237	57,15	0.84104	72,15	0.95240	87,15	0.99885
47 0.01367	12,30	0.21644	27,30	0.46175	42,30	0.67559	57,30	0.84339	72,30	0.95372	87,30	0.99905
48 0.01396	12,45	0.22070	27,45	0.46561	42,45	0.67880	57,45	0.84573	72,45	0.95502	87,45	0.99923
49 0.01425	13	0.22495	28	0.46947	43	0.68200	58	0.84805	73	0.95630	88	0.99939
50 0.01454	13,15	0.22920	28,15	0.47332	43,15	0.68518	58,15	0.85035	73,15	0.95757	88,15	0.99953
51 0.01483	13,30	0.23345	28,30	0.47716	43,30	0.68835	58,30	0.85264	73,30	0.95882	88,30	0.99966
52 0.01513	13,45	0.23769	28,45	0.48099	43,45	0.69151	58,45	0.85491	73,45	0.96005	88,45	0.99976
53 0.01542	14	0.24192	29	0.48481	44	0.69466	59	0.85717	74	0.96126	89	0.99985
54 0.01571	14,15	0.24615	29,15	0.48862	44,15	0.69779	59,15	0.85941	74,15	0.96246	89,15	0.99991
55 0.01600	14,30	0.25038	29,30	0.49242	44,30	0.70091	59,30	0.86163	74,30	0.96363	89,30	0.99996
56 0.01629	14,45	0.25460	29,45	0.49622	44,45	0.70401	59,45	0.86384	74,45	0.96479	89,45	0.99999
57 0.01658	15	0.25882	30	0.50000	45	0.70711	60	0.86603	75	0.96593	90	1.00000
58 0.01687	15,15	0.26303	30,15	0.50377	45,15	0.71019	60,15	0.86820	75,15	0.96705
59 0.01716	15,30	0.26724	30,30	0.50754	45,30	0.71325	60,30	0.87036	75,30	0.96815
60 0.01745	15,45	0.27144	30,45	0.51129	45,45	0.71630	60,45	0.87250	75,45	0.96923

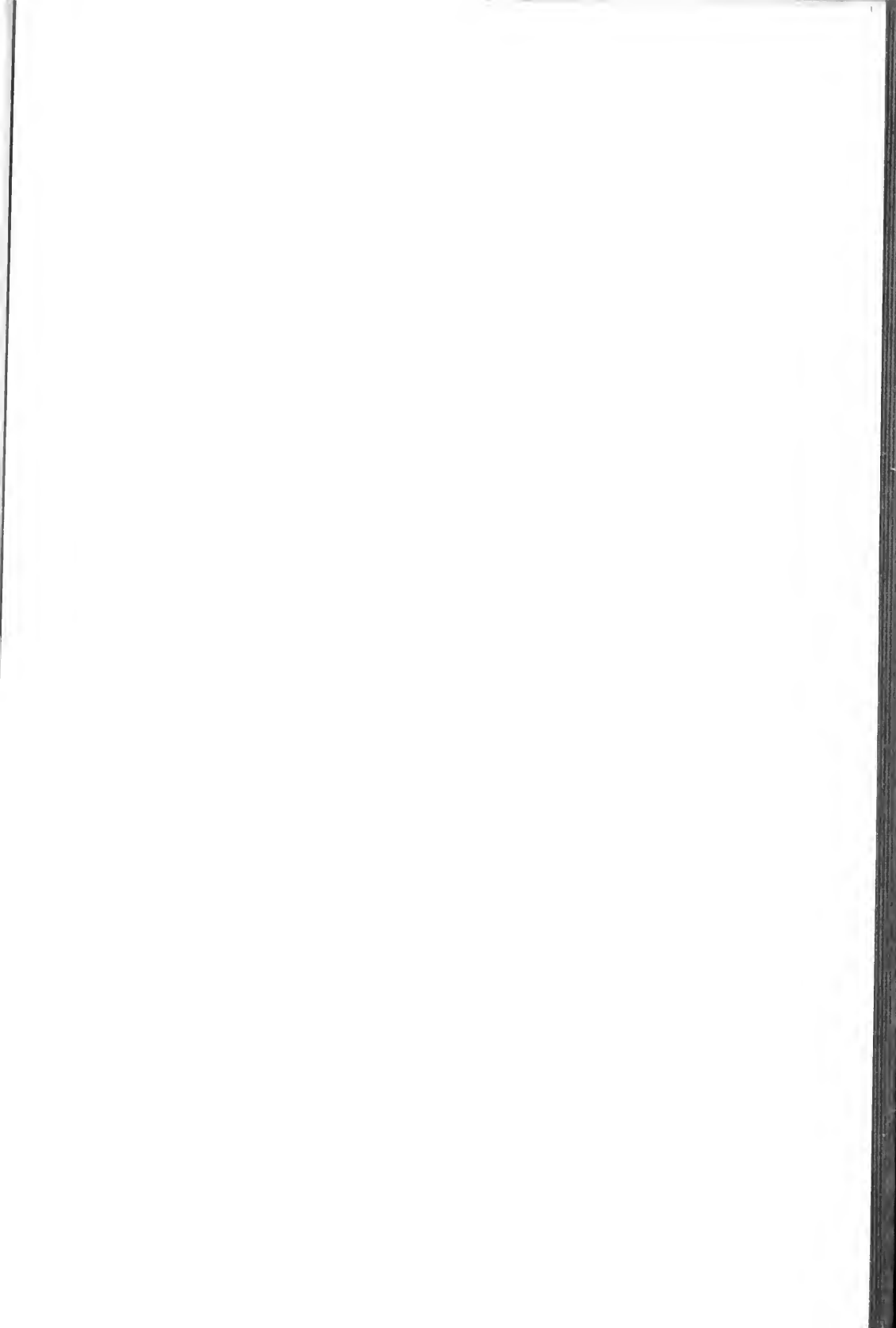

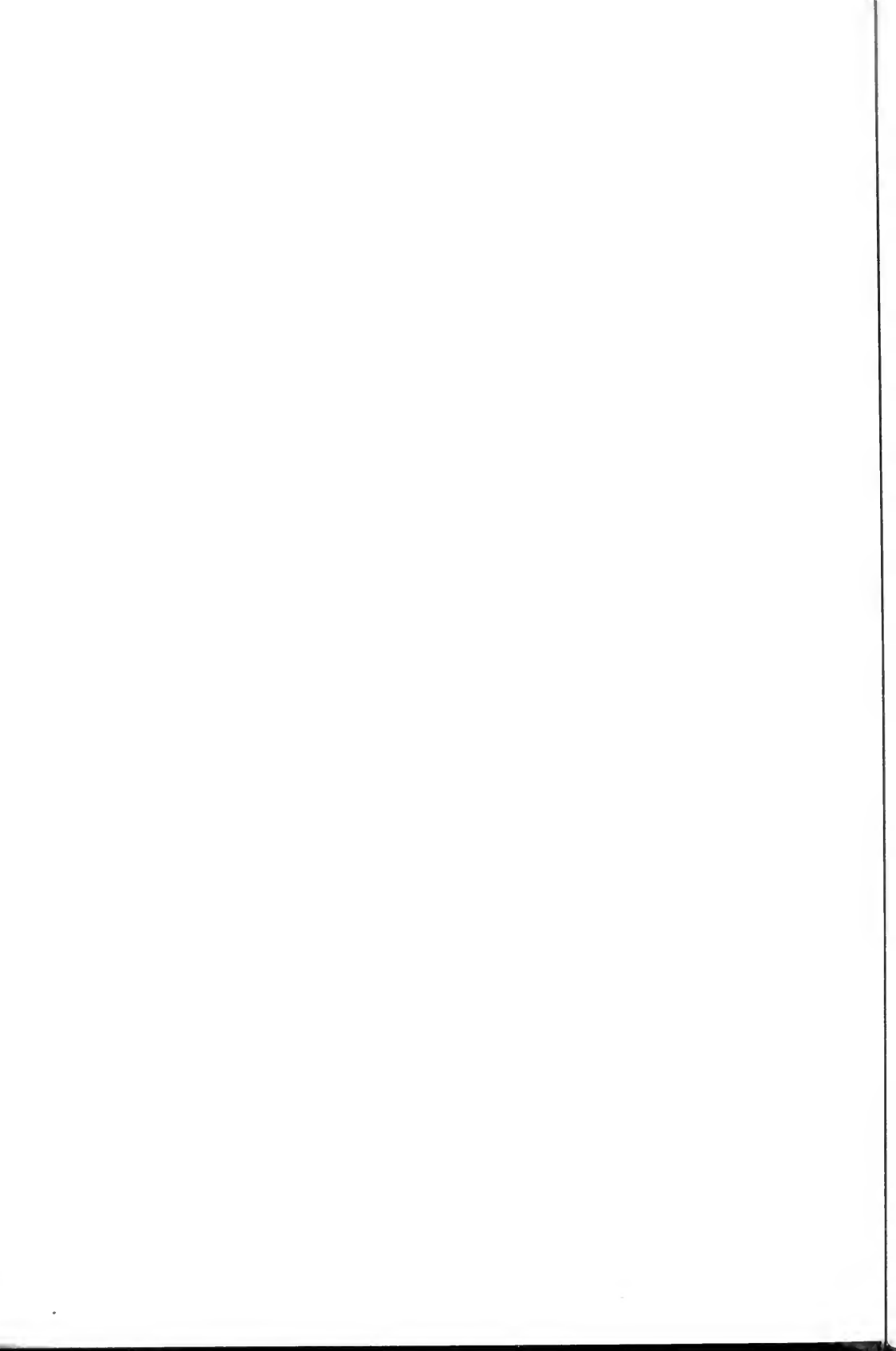

Interpolation with Natural Sines:— If one cannot find a sine exactly corresponding with an angle in the table, or an angle corresponding with a sine found in solving a problem, the sine or angle can be closely approximated by the method of *Interpolation*: Find the sine in the table nearest the sine whose angle is to be determined. Get the difference of the sines of the angles greater and less than the sine whose angle is to be determined. That will give the increase of sine for that region of the arc for 15 minutes. Divide this increase by 15 and it will give with approximate accuracy the increase for 1 minute. Now get the difference between the sine whose angle is to be determined and the sine just below it in value. Divide this difference by the amount found necessary for an increase in angle of 1 minute and the quotient will give the number of minutes the sine is greater than the next lower sine whose angle is known. Add this number of minutes to the angle of the next lower sine and the sum will represent the desired angle. Or if the sine whose angle is to be found is nearer in size to the sine just greater, proceed exactly as before, getting the difference in the sines, but subtract the number of minutes of difference and the result will give the angle sought. For example, take the case in Section 108 where the sine of the angle of $28^{\circ} 54'$ is given as 0.48327. If one consults the table the nearest sines found are 0.48099, the sine of $28^{\circ} 45'$, and 0.48481, the sine of 29° . Evidently then the angle sought must lie between $28^{\circ} 45'$, and 29° . If the difference between 0.48481 and 0.48099 is obtained, $0.48481 - 0.48099 = 0.00382$, and if this increase for $15'$ be divided by 15 it will give the increase for 1 minute; $0.00382 \div 15 = 0.000254$. Now the difference between the sine whose angle is to be found and the next lower sine is $0.48327 - 0.48099 = 0.00228$. If this difference be divided by the amount found necessary for 1 minute it will give the total minutes above $28^{\circ} 45'$, $0.00228 \div 0.000254 = 9$. That is, the angle sought is 9 minutes greater than $28^{\circ} 45' = 28^{\circ} 54'$.

Table of Metric and English Measures:—

Meter (unit of length) = 100 centimeters; 1000 millimeters; 1,000,000 microns (μ); 39.3700 inches; 3.2808 feet.
Centimeter (cm.) = 10 millimeters; 10,000 microns; 0.01 meter; 0.3937 (2 5) inch.
Millimeter, (mm.) = 1,000 microns (μ); 0.1 cm.; 0.001 meter; 0.03937 (1 25) inch).
Micron (unit of length in micrometry) (μ) (§246) = 0.001, one thousandth of a millimeter; 0.000001, one millionth of a meter; 0.00003937 (1 25000) inch.
Kilometer = 1000 meters; 0.621 or 5/8 mile.
Liter (unit of capacity) = 1000 cubic centimeters (or milliliters); 1 quart approximately.
Gram (unit of weight) = 1 cc. of water; 15.432 grains.

Kilogram = 1000 grams; 2.2046 (2 1/5 lbs.).
Yard, 3 feet, 36 inches; 0.9144 meter; 91.4399 cm.
Foot = 1 3/4 yard; 12 inches; 0.3048 meter; 30.48 cm.
Inch = 1 3/16 yard; 1 1/2 foot; 2.54 cm.; 25.4 mm.
Mile = 1760 yards; 5280 feet; 1.61 kilometers.

Quart = 1/4 gallon; 2 pints; 32 fluid ounces; 0.947 liter (947 cc.). (U. S. liquid).
Fluid ounce = 8 fluidrachms; 1/32 of a quart; 1/16 pint; 29.574 cubic centimeters (30 cc. approximately).
Ounce avoirdupois = 437 1/2 grains; 28.349 grams.
Ounce apothecaries or Troy = 480 grains; 31.103 grams.
Pound (avoirdupois) = 16 ounces, 453.6 grams.

To Change from Centigrade to Fahrenheit and the Reverse:—

From centigrade to Fahrenheit: Multiply the degrees centigrade by 9/5 and add 32. Example: $20^{\circ} \text{C.} = 20 \times 9/5 + 32$ or 68°F.

From Fahrenheit to centigrade: Subtract 32 and multiply by 5/9. Example: $77^{\circ} \text{F.} = 77 - 32 \times 5/9$ or 25°C.

To change from centigrade to absolute temperature and the reverse: Add 273 to the degrees in centigrade and the sum will be the absolute temperature. Example. Ice melts at 0°C. or $0^{\circ} + 273^{\circ} = 273^{\circ}$ absolute, and water boils at 100°C. or $100^{\circ} + 273^{\circ} = 373^{\circ}$ absolute. If the absolute temperature is given subtract 273 and the result will be the temperature on the centigrade scale. Example: Ice melts at 273° absolute, $273^{\circ} - 273^{\circ} = 0^{\circ}$, that is, ice melts at 0°C. See Fig. 36, where absolute temperature is given.

American Manufacturers and Dealers in Microscopes and Microscopical Supplies:—

The Bausch & Lomb Optical Company, Rochester, New York.
The Spencer Lens Company, Buffalo, New York.
The Gundlach Manhattan Optical Company, Rochester, New York.
Joseph Zentmayer, Philadelphia, Pa.
Edward Pennock, 3609 Woodland Ave., Philadelphia, Pa.
The Corning Glass Works, Corning, New York. (Daylight glass and Pyrex glass).
C. H. Stoelting Company, Chicago, Ill.
Williams Brown & Earle, Philadelphia, Pa.
Arthur H. Thomas Company, Philadelphia Pa.
Ernst Leitz, Optician, New York City, N. Y.
Eimer & Amend, New York City, N. Y.
The G. Cramer Dry Plate Company, St. Louis, Mo. (Photographic plates and color screens).
The Eastman Kodak Co., Rochester, N. Y. (Dry plates, color screens, velox developing paper).
Anso Company, Binghamton; N. Y. (Cyclo developing papers, etc.).
Lumiere Jougla Co., New York. (Autochrome plates).

When ready to buy a microscope or supplies get the latest catalogues of the manufacturers; then the newest models can be seen and the current prices determined.

