

ONE OF  
THE BOOKS  
OF

WORLD

WORLD

OF

GONZALESCO











En. [unclear] [unclear]

By Andrew Pritchard



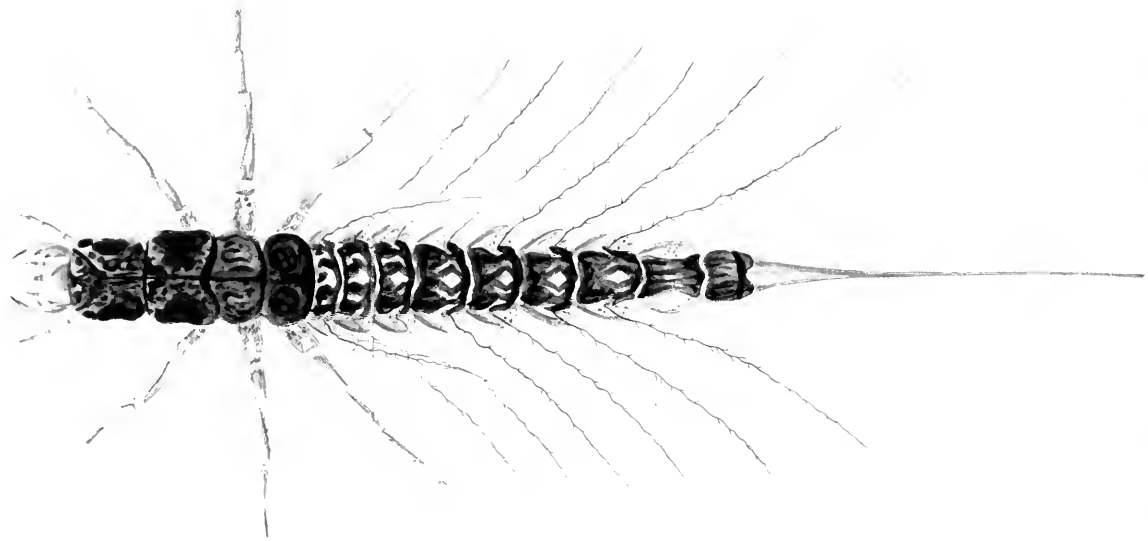

# MICROSCOPIC OBJECTS,

ANIMAL,

VEGETABLE AND MINERAL:

WITH

INSTRUCTIONS FOR PREPARING AND VIEWING THEM.

---

LONDON:

WHITTAKER AND CO., AVE MARIA LANE.

—  
1847.

---

J. DARKIN, PRINTER, 2, CLOUDESLEY-STREET, ISLINGTON.



# CONTENTS.

---

|  |      |
|--|------|
| FRONTISPIECE—Aquatic Larva, magnified (from an original unpublished Drawing).                            | PAGE |
| PREFACE . . . . .  | iii. |
| CATALOGUE OF MICROSCOPIC OBJECTS . . . . .   | 1    |
| CHAPTER I.—Notes on Recent Improvements in Microscopes   | 19   |
| CHAPTER II.—General Observations on the Catalogue of Microscopic Objects . . . . .                       | 27   |
| CHAPTER III.—Test Objects . . . . .  | 99   |
| CHAPTER IV.—Animals and Plants in which the Circulation has been observed under the Microscope . . . . . | 122  |
| CHAPTER V.—Viewing Microscopic Objects by Polarized Light  | 127  |
| CHAPTER VI.—Preparing Objects for the Microscope . . . . .   | 131  |
| CHAPTER VII.—Mounting Microscopic Objects . . . . .  | 142  |
| CHAPTER VIII.—Microscopical Fragments . . . . .  | 153  |
| CHAPTER IX.—Achromatic Microscopes . . . . .   | 173  |
| CHAPTER X.—The Megaloscope (a new Optical Instrument)  | 187  |

39753



## P R E F A C E.

---

THIS little work is intended as an assistant to the tyro in Microscopy—a sort of A B C, or Hornbook—at most, in the light of a “Primer containing Words of one and two Syllables.” Not that the author assents to the notion that for rudimentary works excellence is not required. On the contrary, he believes that elementary instruction, to be really efficient, requires even a greater amount of knowledge of and penetration into the human mind, than is required for the composition of books intended for readers of higher attainments. He regrets, however, that, in the following pages, circumstances have prevented him from attaining even an approach to his own standard.

The want of a practical work on Microscopic Objects has long been felt. Many possessors of valuable Microscopes bring them out on state occasions for the admiration of their friends; but rarely can they exhibit half-a-dozen objects properly. Either they employ a magnifier too high or too low, or the illumination is defective. The design of this book is to obviate this want of

knowledge, and to supply, from actual experience, information and directions that shall render the Microscope instructive as well as amusing.

The only original works similar to the present are Baker's "*Employment for the Microscope*," which work modern improvements have rendered obsolete, and Pritchard's "*Microscopic Cabinet*," and his "*List of 2000 Objects, with Remarks*;" both of which are out of print. From the two latter works copious extracts have been made; and indeed wherever the source of a passage marked with inverted commas is not given, the reader may consider it as taken from one or other of them.

The original matter, including the directions for preparing and mounting microscopic objects, is the result of the writer's own experience, and for it he does not stand indebted to any other source, private or public. He believes that it will be found of practical value to all who desire to use the Microscope efficiently.

The instructions for preparing some of the more difficult subjects—as thin sections of fossils, &c.—may not in some cases be needed, as a single specimen is sufficient, and can be obtained from a respectable optician at a trifling cost—much less, indeed, than the price of the tools which would be required to prepare it. This latter circumstance, added to the facility with which the objects in question can, for a few pence, be conveyed by post to the most distant parts of the British Islands, is well deserving of the notice of those who wish to make a good use of their Microscopes. The

same remark, however, does not apply to a very large number of objects of great interest, as described in this work. With the help of the directions contained herein, most of those objects may be procured at a small cost of either time or money.

The concluding chapter (on the Megaloscope) is a posthumous Essay by the late Dr. Goring. The subject of it will be, to many persons, both novel and interesting. It is written in the Doctor's usual peculiar though forcible style.

In the Catalogue of Microscopic Objects the English names are often mixed with the technical. This may perhaps be objected to by systematic naturalists: but this little book being designed for the general observer, the course herein adopted in this respect was considered as, on the whole, the best.

*London; April, 1847.*





# CATALOGUE

OF

## MICROSCOPIC OBJECTS.\*

NOTE.—t. s. stands for transverse section.

v. s. " vertical section.

th. s. " thin section.

### ORGANIC OBJECTS.

#### ANIMAL.

Acanthosoma  
 Acari (Mites)  
 Acarus, from  
     Currant-tree  
 Acarus domesticus  
 Acarus passerinus  
 Acarus, Fig  
 Acarus Scabiei  
 Acarus, Tortoise  
 Acheta domestica  
 Acrydium subulatum  
 Aërating Leaflets, La.  
     Libellula  
 Air-bladder, Fly?  
 Alucita 20-dactyla  
 Ammonites in flint

**Anatomical Prep.**

Acini Hepatis Erinacei  
     Europ. per venam  
     portæ  
 Corpuscula Malpighii ex  
     rene scrofae  
 Hepar Hominis; arteriæ  
     rubrae, vena portar.  
     alba, vena hepat. flava

Intestinum tenue Testu-  
     dinis Mydæ  
 Morbus Brightii  
 Oviductus Emydis Eu-  
     rop.; arteriæ rubrae,  
     venæ albæ  
 Pulmo Testudinis Græcæ;  
     arteriæ rubrae, venæ  
     albæ  
 Textus cellularis subcu-  
     taneus Hominis  
 Tubuli uriniferi Corvi  
     Picæ  
 Villi intestin. Psittaci  
     Æstivi

—

Aneurus lævis  
 Anobium tessellatum  
 Ant  
 Ant, African

**Antennæ.**

A. Agaon paradoxum  
 A. Aphodius Fossor.  
 A. Ascalaphus  
 A. Bombyx  
 A. Carabus  
 A. Cerambyx

A. Claviger longicornis  
 A. Cockroach  
 A. Ctenophora  
 A. Diaperis Boleti  
 A. Elater cupreus  
 A. Gnat  
 A. Leucoma Salicis  
 A. Melolontha mas  
 A. Midge Fly  
 A. Mole Cricket  
 A. Moth  
 A. Odonestis Potatoria  
 A. Psychoda ocellaris  
 A. Staphylinus  
 A. Tiger Moth

—

Aphis  
 Aphis vastator  
 Arcopagus  
 Argyrolepia tesserana  
 Argyromis  
 Argyrosetia Goddardella  
 Atropus (Death-watch)  
 Bee, Leaf-cutting  
 Bee, Long-horned

\* See Chapter II.







|   |                           |   |
|---|---------------------------|---|
| Bee, Wild                                 | Bug, Rostrum              | Coralline, White                          |
| Beetle, Asparagus                         | Bug, Russian              | Coreus marginatus                         |
| Beetle, Bronze                            | Buprestes                 | Crab, minute                              |
| Beetle, Cryptophagous                     | Buprestes gigans          | Culex (Gnat)                              |
| Beetle, Diamond                           | Butterfly                 | Culex pipiens                             |
| Beetle, Musk                              | Butterfly, Brimstone      | Curculio, Bacchus                         |
| Beetle, Nettle                            | Butterfly, Emperor        | Curculio, Chinese                         |
| Beetle, Oak                               | Butterfly, Lycena         | Curculio cyanipes                         |
| Beetle, Oil                               | Butterfly, Papilio Apollo | Curculio, foreign                         |
| Beetle, Thistle                           | Butterfly, Pink Underwing | Curculio, Grain                           |
| Beetle, Unicorn                           | Butterfly, Red-winged     | Curculio imperialis                       |
| Beetle, Water                             | Butterfly, Swallow-tail   | Curculio, Nettle                          |
| Blaps                                     | Cantharis                 | Curculio, Oak                             |
| Blatta (Cockroach)                        | Capsus ater               | Curculio Rumicis                          |
| Blatta orientalis                         | Capsus spissicornis       | Curculio spectabilis                      |
|   | Cassida (Tortoise Beetle) | Curculio scrophularia                     |
|   | Centipede                 | Curculio, Silver                          |
|   | Cerambyx                  | Curculio, Thistle                         |
|   | Chalcis clavipes          | Cynips (Dog-rose)                         |
|   | Chironomus plumosus       | Cynips, Oak                               |
|   | Chrysis (Golden Fly)      | Cynips, Rose                              |
|   | Chrysomela fulgida        | Darts, Snail                              |
|   | Cicada                    | Dermestes                                 |
|   | Cicada, small             | Dioctria $\text{\textcircled{E}}$ landica |
|   | Cicada viridis            | Disc, Foot                                |
|   | Cicindela                 | Dolichopus                                |
|   | Cicindela (Scale Beetle)  | Donacia Lemna                             |
|   | Cimbex                    | Dorsal Vessel, La. Ephem.                 |
|   | Cimex lectularius         | Dorytomus maculatus                       |
|   | Coccinella dispar         | Dragon Fly                                |
|   | Cockchafer                | Dytiscus marginalis                       |
|   | Common Gnat               | Dytiscus, Male                            |
|   | Copper Moth               | Dytiscus circumflexus                     |
|   | Coral, branched           | Earwig                                    |
|   | Coral, indented           | Earwig, small                             |
|   | Coral, Red, t. s.         | Egg-shell, th. s.                         |
|   | Coral, Red, v. s.         |   |
|   | Coral, Rock               |   |
|   | Coral, White, t. s.       |   |
|   | Coralline, Red            |   |
|   |                           | <b>Eggs.</b> — <i>Insects.</i>            |
|   |                           | Eggs, Atlas Moth                          |
|   |                           | Eggs, Bufftip Moth                        |
| <b>Blood.</b>                             |                           |   |
| Blood, Eel                                |                           |   |
| Blood, Frog                               |                           |   |
| Blood, Human, discs                       |                           |   |
| Blood, La. Ephemera                       |                           |   |
| Blood, Lizard                             |                           |   |
| Blood, Sheep                              |                           |   |
| Blood, Swallow                            |                           |   |
| <b>Bone.</b>                              |                           |   |
| Bone, Calcined                            |                           |   |
| Bone, Cuttlefish, par. s.                 |                           |   |
| Bone, Cuttlefish, perp. s.                |                           |   |
| Bone, Human Femur, t. s.                  |                           |   |
| Bone, Human Femur, v. s.                  |                           |   |
| Bone, Mastodon                            |                           |   |
| Bone, Necrosis                            |                           |   |
| Bony structure in scales<br>of Lepidosrus |                           |   |
| —   |                           |   |
| Branchiæ                                  |                           |   |
| Bristle, Hog, black                       |                           |   |
| Bug                                       |                           |   |
| Bug, Canadian                             |                           |   |

Eggs, Bug  
 Eggs, Cabbage Butterfly  
 Eggs, Blatta  
 Eggs, Field Cimex  
 Eggs, Flea  
 Eggs, Fly  
 Eggs, Grasshopper  
 Eggs, Lacquey Moth  
 Eggs, Louse  
 Eggs, Magpie Moth  
 Eggs, Moth  
 Eggs, Oak Egger Moth  
 Eggs, *Phalæna neustria*  
 Eggs, Water Beetle

Elaphrus  
 Elater, Spring Beetle  
 Elater, Spine

**Elytra.**—*Insects.*

Elytron  
 Ely. Beetle  
 Ely. Bronze Beetle  
 Ely. Buprestis  
 Ely. Cantharis  
 Ely. Carabus  
 Ely. Chrysis  
 Ely. Chrysomela  
 Ely. Cicada  
 Ely. Cicindela  
 Ely. Cicindela, Brazil  
 Ely. Corixa  
 Ely. Curculio  
 Ely. Dermestes  
 Ely. Diamond Beetle  
 Ely. Dytiscus  
 Ely. Elaphus  
 Ely. Flame Beetle  
 Ely. Golden Beetle  
 Ely. Gyrinus  
 Ely. Lytta

Ely. Musk Beetle  
 Ely. Notonecta  
 Ely. Pupa Agrion  
 Ely. Rose Beetle  
 Ely. Stenus  
 Ely. Unicorn Beetle  
 ———  
 Entozoa in Human Muscle  
 Ephemera (Day Fly)  
 Ephemera, Pupa  
 Epidermis of Lobster-shell

**Exuviae.**—*Insects.*

Exuv. Bug  
 Exuv. Boat Fly  
 Exuv. young Caterpillar  
 Exuv. Colymbetes  
 Exuv. Dermestes  
 Exuv. Dytiscus  
 Exuv. La. Ephemera  
 Exuv. La. Gnat  
 Exuv. Pu. Gnat  
 Exuv. Hydrophilus  
 Exuv. Libellula  
 Exuv. Tortoise Beetle  
 ———  
 Exuv. Snake  
 Exuv. Spider  
 ———  
 Eye, Choroid Coat, showing pigment cells  
 Eye, Iris, showing disposition of fibres

**Eyes.**—*Fish.*

Eye, Cod  
 Eye, Gold Fish  
 Eye, Haddock  
 Eye, Herring  
 Eye, Salmon  
 Eye, Sole  
 Eye, Turbot

**Eyes.**—*Compound.*

Eyes, *Æshna*  
 Eyes, *Acrocinus*  
 Eyes, Agrion, 12,000  
 Eyes, Ant, 50  
 Eyes, *Argyroneta*  
 Eyes, *Attus parus*, 8  
 Eyes, Bee  
 Eyes, Beetle  
 Eyes, Black Beetle  
 Eyes, Bombardier  
 Eyes, *Bombyx mor.*  
 Eyes, Boat Fly  
 Eyes, Buprestis  
 Eye, Butterfly  
 Eyes, *Cerambyx*  
 Eyes, Cicada  
 Eyes, Cicindela  
 Eyes, *Clubiona accent.*  
 Eyes, Cockchafer  
 Eyes, Cockroach  
 Eyes, Crayfish  
 Eyes, Cricket  
 Eyes, *Ctenus dubius*  
 Eyes, Curculio  
 Eyes, *Dolomedes marg.*  
 Eyes, Dragon Fly  
 Eyes, Dynastes  
 Eyes, *Dysdera erythr.*  
 Eyes, Dytiscus  
 Eyes, Earwig  
 Eyes, *Epeira diadema*  
 Eyes, Ephemera  
 Eyes, *Ephemera vulg.*  
 Eyes, *Eresus cinnabe*  
 Eyes, Field Cimex  
 Eyes, Flea  
 Eyes, Gnat  
 Eyes, Grasshopper  
 Eyes, Gyrinus, 4 clusters





- Eyes, Hawk Moth, 20,000  
 Eyes, *Helix pomatia*  
 Eyes, House Fly, 8000  
 Eyes, Hunting Spider  
 Eyes, Hydromet. stagn.  
 Eye, Ichneumon  
 Eyes, La. Dytiscus  
 Eyes, La. Hydrophilus  
 Eyes, La. Tussock Moth  
 Eyes, Latrodecta  
 Eyes, Libellula  
 Eye, Lobster  
 Eye, Locust  
 Eyes, *Lycosa vorax*  
 Eyes, Mantis  
 Eyes, Menelaus  
 Eyes, Millipedes  
 Eyes, Moth  
 Eyes, Mole Cricket  
 Eyes, Mordella, 25,088  
 Eyes, *Musca domestica*  
 Eyes, *Mygale avicularis*  
 Eyes, *Mygale cæmentata*  
 Eyes, Nepa  
 Eyes, Panorpa  
 Eyes, Papilio, 17,000  
 Eyes, Peach Fly  
 Eyes, Phalaena Cossus, 11,300  
 Eyes, Scarabæus, 3180  
 Eyes, *Segestria perfida*  
 Eyes, Shrimp  
 Eyes, Silpha  
 Eyes, Sphasus Indianus  
 Eyes, Spider  
 Eyes, Staphylinus  
 Eyes, Stomoxys  
 Eyes, Tabanus  
 Eyes, Wasp
- 
- Feather
- Feather, Bird Paradise  
 Feather, Humming Bird  
 Feather, Lark  
 Feather, Partridge  
 Feather, Peacock  
 Feather, Red Ibis  
 Feather, Shrike  
 Feather, Yellowhammer  
 Femora, Flea  
 Fin, small Fish  
 Fire Fly  
 Flea, male  
 Fluke of Sheep  
 Fly, Aquatic  
 Fly, Musquito
- Feet.**—*Insects.*
- Foot, *Acilius canalic.*  
 Foot, *Carabus monilis*  
 Foot, Common Fly  
 Foot, Chrysis  
 Foot, *Cimbex lutea*  
 Foot, Curculio  
 Foot, Diamond Beetle  
 Foot, Dioctria  
 Foot, Dung Fly  
 Foot, *Dytiscus circumfl.*  
 Foot, *Dytiscus dimidiat.*  
 Foot, *Dytiscus marginat.*  
 Foot, Flame Beetle  
 Foot, *Hydaticus transv.*  
 Foot, *Hydrachna herm.*  
 Foot, Rhagium  
 Foot, *Smerinthus ocell.*  
 Foot, Tussock Moth, La.
- 
- Forceps, Earwig
- Fossils.**  
 (*Thin Sections.*)
- Entomostraceus, Burdick-house Limestone
- Flint, with Foraminifera  
 Flint, with Xanthidii  
 Turbinolia, from Bathgate, N.B.
- 
- Frog-hoppers (*Cicada*)  
 Fulgora candelaria  
 Gad Fly  
 Gall Flies (*Cynips*)  
 Gerris paludum  
 Gnat, Common  
 Gnat, Plumed  
 Gothic Moth  
 Gyrinus natator
- Hair.**—*Animals, &c.*
- Hair, *Acilius canalicul.*  
 Hair, Ant-eater  
 Hair, Axis Deer  
 Hair, Badger  
 Hair, Bat  
 Hair, Bee  
 Hair, Beard, tubular  
 Hair, Bird-catching Spider  
 Hair, Bush Kangaroo  
 Hair, Cashmere Goat  
 Hair, Caterpillar  
 Hair, Caterpillar, Plumed  
 Hair, Chittah  
 Hair, Civet Cat  
 Hair, Coati Mundi  
 Hair, Corsican Deer  
 Hair, Wapiti Deer  
 Hair, Dermestes, La  
 Hair, Dormouse  
 Hair, Elephant, t. s  
 Hair, Eucera longic.  
 Hair, Field Mouse  
 Hair, Flying Squirrel  
 Hair, Fox  
 Hair, Georgian Seal

- Hair, Golden Agouti  
 Hair, Hog Deer  
 Hair, Hornbut  
 Hair, Human  
 Hair, Human, t. s.  
 Hair, Indian Antelope  
 Hair, Indian Bee  
 Hair, Indian Rat  
 Hair, Infant  
 Hair, Kangaroo Rat  
 Hair, Kinkjue ?  
 Hair, Lemur, Black  
 Hair, Lemur, Red-fronted  
 Hair, Lemur, White-fronted  
 Hair, Lemur, Ruffled  
 Hair, Leopard  
 Hair, Mangue  
 Hair, Marmot  
 Hair, Mole  
 Hair, Monkey, red-handed  
 Hair, Mouse  
 Hair, Melecta punctata  
 Hair, Nylghau Antelope  
 Hair, Opossum, Sooty  
 Hair, Opossum Ursine  
 Hair, Opossum, Virginian  
 Hair, Ornithorhynchus  
 Hair, Persian Cat  
 Hair, Persian Sheep  
 Hair, Puma  
 Hair, Polar Bear  
 Hair, Rabbit  
 Hair, Racoon  
 Hair, Sable  
 Hair, Seal  
 Hair, Siberian Fox  
 Hair, Sloth Bear  
 Hair, Spider  
 Hair, Spider, branched  
 Hair, Spotted Cavaï
- Hair, Stag Beetle  
 Hair, Sun Bear  
 Hair, Tiger  
 Hair, Tussock Moth, La.  
 Hair, Vampire Bat  
 Hair, White Cat  
 Hair, Wing Tipula  
 Haliplus elevatus
- Heads.**—*Insects.*  
 Head, Ant Lion  
 Head, Asilus  
 Head, Bee  
 Head, Bombylius maj.  
 Head, Butterfly  
 Head, Chironomus.  
 Head, Cicada  
 Head, Cicindela sylv.  
 Head, Conops  
 Head, Chrysis Perla  
 Head, Black Curculio  
 Head, Oak Curculio  
 Head, Diamond Beetle  
 Head, Dragon Fly  
 Head, Dytiscus  
 Head, Empis  
 Head, Flea  
 Head, Fly  
 Head, Plumed Gnat  
 Head, Hemerobius  
 Head, Hornet  
 Head, Hydrophilus  
 Head, Libellula  
 Head, Moth  
 Head, Panorpa  
 Head, Psilopus  
 Head, Psocus  
 Head, Scorpion Fly  
 Head, Small Water Beetle  
 Head, Syrphus
- Hemerobius Perla  
 Heribcia  
 Heterocerus obsoletus  
 Hippobosca equina  
 Hoof, Horse, thin section  
 Hoof, Ox, thin section  
 Hydrachna  
 Hydrochus crenatus  
 Hydrometra stagnorum  
 Hydrophilus  
 Ichneumon  
 Indian Bee
- Infusoria.**  
*Genera that may be mounted.*  
 Achnanthes  
 Actinocyclus  
 Arcella  
 Arthrodesinus  
 Astasia  
 Bacillaria  
 Brachionus  
 Campilodiscus  
 Chilodon  
 Closterium  
 Cocconeis  
 Cocconema  
 Coleps  
 Coscinodiscus  
 Cryptomonas  
 Desmidium  
 Diglena  
 Doxococcus  
 Echinella  
 Enchelys  
 Euàstrum  
 Eudorina  
 Euglena  
 Eunotia  
 Fragillaria  
 Frustulia







|                                    |   |                                    |
|------------------------------------|---|------------------------------------|
| Furcularia                         | Bilin, Bohemia                          | La. Dermestes                      |
| Galliohella                        | Blue-hill, Maine                        | La. Dytiscus                       |
| Glenophora                         | Brighton Pebble                         | La. Ephemera.                      |
| Gloconema                          | Cartel del Pianna                       | La. Flea                           |
| Gomphonema                         | Frauzenbad                              | La. Guat                           |
| Gonium                             | Gainsborough                            | La. Hemerobius                     |
| Hydatina                           | Hollis Cliff, Virginia                  | La. House Fly                      |
| Isthmia                            | Ichaboe Guano                           | La. Hydrophilus, young.            |
| Kolpoda                            | Jutland Slate                           | La. Musca Chamæleon                |
| Loxodes                            | Kent Chalk                              | La. Musca pendula                  |
| Meridion                           | Lincolnshire                            | La. Nemoura                        |
| Microcodon                         | Lunenberg                               | La. Nepa                           |
| Microtheca                         | Neuberg, Danube                         | La. Notonecta, young.              |
| Navicula                           | New Zealand                             | La. Pupa, and Perfect<br>Lady-bird |
| Notommata                          | Oxfordshire                             | La. Tipula                         |
| Odontella                          | Peruvian Guano                          | La. Tortoise Beetle                |
| Oxytricha                          | Piscataway, Maryland                    | —                                  |
| Paramecium                         | Richmond, N.A.                          |                                    |
| Pentasterias                       | St. Fiora                               | Ledra aurita                       |
| Podosphenia                        | Tripoli                                 | Leg, Diamond Beetle                |
| Prorodon                           | West Point, New York                    | Leg, Flame Beetle                  |
| Pyxidicula                         | —                                       | Leg, La. Libellula                 |
| Spirodiscus                        | Jaw, Ant                                | Leg, Moth                          |
| Sphærastrum                        | Jaw, Spider                             | Lepisma saccharina                 |
| Spirillum                          | Julus                                   | Lepisma maritima                   |
| Staurastrum                        | Lacquey Moth                            | Libellula depressa                 |
| Stentor                            | Lady-bird ( <i>Coccinella</i> )         | Libellula virgo                    |
| Striatella                         | Lampyrus noctiluca                      | Lixus productus                    |
| Synecyelia                         | Lancets, Flea                           | Lobster, Fin                       |
| Synedra                            | Lancets, Tabanus Fly                    | Lobster Insect                     |
| Tessararthra                       |   | Locust                             |
| Tessella                           |   | Louse                              |
| Trichoda                           |   | Lung, Human, dry                   |
| Vibrio                             |   | Lung, Human, injected              |
| Volvox                             |   | Mandible, La. Libellula            |
| Xanthidium                         |   | Mask, La. Libellula                |
| <b>Infusoria.</b> — <i>Fossil.</i> |   | Mason Wasp                         |
| <i>Localities.</i>                 |   | May Fly                            |
| Bann, Ireland                      |   | Melolontha Cardui                  |
| Bermuda                            |   | Melolontha chrysochlora            |
|                                    | <b>Larvæ.</b> — <i>Insects.</i>         |                                    |
|                                    | La. Agrion, Tail                        |                                    |
|                                    | La. Aphis vastator, or<br>Potato Insect |                                    |
|                                    | La. Aquatic                             |                                    |
|                                    | La. Boat Fly                            |                                    |
|                                    | La. Carabus                             |                                    |
|                                    | La. Chamleon Fly                        |                                    |
|                                    | La. Cicindela campestris                |                                    |
|                                    | La. Colymbetes                          |                                    |

|                             |                                     |  |
|-----------------------------|-------------------------------------|--|
| Microsetia                  | Pediculus pubis                     | Pylorus of Blatta  |
| Miris vagans                | Petrobius maritimus                 | Pyrochroa coccinea   |
| Mite, Cheese                | Phyllobius uniformis                | Quill, Crane   |
| Mite, Pectinated            | Ploa minutissima                    | Quill, Duck  |
| Mite, Rape-seed             | Podura, Black                       | Quill, Goose   |
| Mite, Teeth                 | Podura fusca                        | Quill, Hedgehog, t. s.                                     |
| Monoculus                   | Podura maritima                     | Quill, Porcupine, t. s.                                    |
| Moth                        | Podura plumbea                      | —  |
| Moth, Plumed                | Poisers, Fly                        | Respiratory System, Caterpillar                            |
| Mouth, <i>Æshna varia</i>   | Polydrusus sericeus                 | Respiratory System, Aquatic Larva.                         |
| Mouth, Spider               | <b>Proboscis.</b> — <i>Insects.</i> | Respiratory System, La. Cossus ligniperda                  |
| Musca Chamæleon             | Prob. Asilius                       | Respiratory System, La. Dytiscus                           |
| Musca pendula               | Prob. Cicada, foreign               | Respiratory, Digestive and Generative Systems, Caterpillar |
| Muscles, young fresh-water  | Prob. Flea                          | Rhagium  |
| Muscular Fibre              | Prob. Common Fly                    | Rhingia rostrata   |
| Nail, Human                 | Prob. Dioctria                      | Rhynchites æquatus   |
| Naucoris cimicoides         | Prob. Empis Fly                     | Rose-Chafer  |
| Nepa cinerea                | Prob. Field Cimex                   | Rostrum, Boat-fly  |
| Nervous Matter              | Prob. Gad Fly                       | Rostrum, Cicada  |
| Nervous System, Bee         | Prob. Gnat                          | Rostrum, Hydrometra  |
| Nervous System, Caterpillar | Prob. House Fly                     | Rostrum, Notonecta   |
| Nitidula                    | Prob. Hydrometra                    | Sand Wasp  |
| Notoxus Monoceros           | Prob. Harvest Tick                  | Saw, Tenthredo   |
| Oniscus (Wood Louse)        | Prob. Hop Fly                       | Saw Fly ( <i>Tenthredo</i> )                               |
| Otiorhynchus notatus        | Prob. Hornet                        | Sargus politus   |
| Ovipositor, Cicada          | Prob. Moth                          | <b>Scales.</b> — <i>Fish.</i>                              |
| Ovip. Cynips                | Prob. Musca, small                  | Sc. Carp   |
| Ovip. Ichneumon             | Prob. Musca pendula                 | Sc. Cod  |
| Ovip. Tipula                | Prob. Panorpa                       | Sc. Dace   |
| Oxycera pulchella           | Prob. Rhingia                       | Sc. Eel  |
| Oyster, Ova of              | Prob. Rhingia rostrata              | Sc. Conger Eel   |
| Paddles, Ephemera           | Prob. Scatophaga                    | Sc. Fossil in flint  |
| Palpi, Cockroach            | Prob. Stomoxys calcitr.             | Sc. Gold Fish  |
| Pancalia— <i>Leenw.</i>     | Prob. Tabanus                       | Sc. Guard Fish   |
| Parasite of Fly             | —                                   | Sc. Gudgeon  |
| Parasite of Pigeon          | Pselaphus                           | Sc. Haddock  |
| Parasite of Spoonbill       | Pterophorus                         |  |
| Parasite of Stork           | Pulex irritans                      |  |
| Pearl, thin section         | Pupa, Nepa                          |  |
|                             | Pupa, Gnat                          |  |







|  |                                |  |
|--|--------------------------------|--|
| Sc. Herring                              | Sc. Machaon                    | Sh. <i>Avicula margaritacea</i>          |
| Sc. Lepidosteus                          | Sc. Morpho Menelaus            | Sh. Etheria                              |
| Sc. Mackarel                             | Sc. 10-plumed Moth             | Sh. Fossil                               |
| Sc. Perch                                | Sc. 20-plumed Moth             | Sh. Fossil, minute                       |
| Sc. Pike                                 | Sc. Magpie Moth                | Sh. Fragments                            |
| Sc. Plaice                               | Sc. Nymphalis Clytem.          | Sh. <i>Gervillia mytiloides</i>          |
| Sc. Roach                                | Sc. Orange-tail Moth           | Sh. <i>Haliotis splendens</i>            |
| Sc. Sea Perch                            | Sc. Papilio Apollo             | Sh. Hammer Oyster, Chin.                 |
| Sc. Soie                                 | Sc. Papilio Cethosia           | Sh. Hippurite                            |
| Sc. Sprat                                | Sc. Papilio Idas               | Sh. Lima scabra                          |
| Sc. Whiting                              | Sc. Papilio Io                 | Sh. Lingula                              |
| <b>Scales.</b> — <i>Insects, &amp;c.</i> | Sc. Papilio Iris               | Sh. <i>Mallens albus</i>                 |
| Sc. Adela Moth                           | Sc. Papilio Paris              | Sh. <i>Mya arenaria</i>                  |
| Sc. Apollo Parnassus                     | Sc. Peacock Butterfly          | Sh. Nacre (Mother of Pearl), t. s.       |
| Sc. Atlas Moth                           | Sc. <i>Petrobius maritimus</i> | Sh. Nacre (Mother of Pearl), v. s.       |
| Sc. Chameleon                            | Sc. Pieris Eucharis            | Sh. Nacre, decalcified                   |
| Sc. Cithoria Julia                       | Sc. Podura plumbea             | Sh. <i>Ostrea edulis</i> (Common Oyster) |
| Sc. Copper Papilio                       | Sc. <i>Polyommatus Acis</i>    | Sh. <i>Perna ephippium</i>               |
| Sc. Currant Sphinx                       | Sc. <i>Polyommatus Adonis</i>  | Sh. <i>Perna</i> Shell, Animal Matter of |
| Sc. Dagger Moth                          | Sc. <i>Polyommatus Alexis</i>  | Sh. Pinna Shell, Fibres of               |
| Sc. Diamond Beetle                       | Sc. <i>Pontia Brassicæ</i>     | Sh. Pinna Shell, Fossil from Oolite      |
| Sc. Dolphin                              | Sc. <i>Pontia Rapæ</i>         | Sh. Pinna <i>nigrina</i> , t. s.         |
| Sc. Dot Moth                             | Sc. Privet Moth                | Sh. Pinna <i>nigrina</i> , v. s.         |
| Sc. Emperor Moth                         | Sc. Puss Moth                  | Sh. <i>Pleurorhynchus</i>                |
| Sc. <i>Euplœa limniacea</i>              | Sc. Red Underwing              | Sh. Spiral, section                      |
| Sc. Flying-fish                          | Sc. Silkworm                   | Sh. <i>Terebratula</i>                   |
| Sc. Forbicina polypoda                   | Sc. <i>Tinea vestianella</i>   | Sh. <i>Unio occidentis</i>               |
| Sc. Forester Moth                        | Sc. Tiger Moth                 | —  |
| Sc. Gnat's Head                          | Sc. Tussock Moth               | —  |
| Sc. Gnat's Wing                          | Sc. <i>Urania Leilus</i>       | —  |
| Sc. Goat Moth                            | —                              | —  |
| Sc. Grey Mullet                          | Scarabæus auratus              | Shepherd Spider                          |
| Sc. House Moth                           | Scolopendra                    | Silk fibre                               |
| Sc. Hunting Spider                       | Scolopendra, British           | Sirex Dromedarius                        |
| Sc. Lepisma                              | Scorpion Fly                   |  |
| Sc. <i>Lepisma saccharina</i>            |                                | <b>Skin.</b>                             |
| Sc. <i>Lepisma polypoda</i>              |                                | Skin, Adder                              |
| Sc. Lady of the Wood                     | <b>Shell.</b>                  | Skin, Boa Constrictor                    |
| Sc. <i>Lycæna Arion</i>                  | ( <i>Thin Sections.</i> )      | Skin, European                           |
| Sc. <i>Lycæna Argus</i>                  | Sh. <i>Anatina olen</i>        | Skin, Flying Fish, Chin.                 |
|  | Sh. <i>Anomia ephippium</i>    |  |

|                                       |                           |                                 |
|---------------------------------------|---------------------------|---------------------------------|
| Skin, La. Brassica                    | Stomach, House Fly        | T. Swine                        |
| Skin, La. Buftip Moth                 | Stomach, Staphylinus      | T. Tadpole                      |
| Skin, La. Caterpillar                 | —                         | T. Tiger                        |
| Skin, La. Dytiscus                    | Stratiomys Chamæleon      | T. Walrus                       |
| Skin, La. Lacquer Moth                | Strophosomus Coryli       | T. Whale, Sperm                 |
| Skin, La. Musca Chamæ.                | Sucker, Aphis Quercus     | <b>Teeth.</b> — <i>Fossil.</i>  |
| Skin, La. Pontia Brassicæ             | Sucker, Cimex nigricolor. | ( <i>Thin Sections.</i> )       |
| Skin, La. Satin Moth                  | Sucker, Cleg.             | T., f. Holoptychus              |
| Skin, La. Yellow Underwing            | Sucker, Water Bug         | T., f. Megalichthys             |
| Skin, Lizard                          | —                         | T., f. Myliobatis               |
| Skin, Lumpsucker Fish                 | Swan's Down               | T., f. Shark                    |
| Skin, Negro                           | Tabanus (Horse Fly)       | —                               |
| Skin, Snake                           |                           | Tenebrio, Antenna               |
| Skin, Sole                            |                           | Tenthredo nassata               |
| Skin, Squalus                         |                           | Teredo navalis                  |
| —                                     |                           | Termes (White Ant)              |
| Spider, Field                         | <b>Teeth.</b>             | Termes pulsator                 |
| Spider, Hunting                       | ( <i>Thin Sections.</i> ) | Thorax, Diamond Beetle          |
| Spider, Web, Clubiona                 | T. Ass                    | Threads, Garden Spider          |
| Spine, Echinus, small                 | T. Bear, Molar            | Thrips, minute                  |
| Spine, Echinus, tr. s.                | T. Cat-fish               | Ticks, Hippobosca               |
| Spinnerets, Spider                    | T. Cheese-mite            | Tick, Horse                     |
| Spiracle, La. Melolontha              | T. Cod-fish               | Ticks, Pigeons                  |
| Spiracles, La. Fly                    | T. Cow, Incisor           | Tick, Sheep                     |
| Sponge, Fossil                        | T. Cow, Molar             | Tipula tritici                  |
| Sponge, Turkey, Sand from             | T. Dog                    | Tongue, Bee                     |
| Sponge, E. I., Gemmules               | T. Elephant               | Tongue, Bombus                  |
| Sponge, Spiculi of                    | T. Elephant, Grinder      | Tongue, La. Ephemera            |
| Sponge, Siliceous                     | T. Fossil Fish            | Tongue, Hornet                  |
| Staphylinus                           | T. Hippopotamus           | Trachea, Caterpillar            |
| Sting, Bee                            | T. Horse, Incisor         | Trachea, La. Dytiscus           |
| Sting, Wild Bee                       | T. Horse, Molar           | Wasp                            |
| Sting, Hornet                         | T. Human, Canine          | Web, Clubiona atrox             |
| Sting, Sphex                          | T. Human, Incisor         | Weevil, Corn                    |
| Sting, Wasp                           | T. Human, Molar           | Weevil, Nut                     |
| Stomach, Bee                          | T. Human in jaw           | Whalebone                       |
| Stomach, Black Beetle                 | T. Locust                 |                                 |
| Stomach, Dytiscus                     | T. Mantis                 |                                 |
| Stomach, with Pyloric Valve, Dytiscus | T. Salmon                 |                                 |
|                                       | T. Sea-horse              |                                 |
|                                       | T. Sheep                  |                                 |
|                                       | T. Slug                   |                                 |
|                                       | T. Snail                  |                                 |
|                                       |                           | <b>Wings.</b> — <i>Insects.</i> |
|                                       |                           | Wing, Acrida viridis            |
|                                       |                           | Wing, Admiral Butterfly         |







Wing, Agrion  
 Wing, Apollo Butterfly  
 Wing, Aquatic Fly  
 Wing, *Ægeria* Tipuli  
 Wing, *Blatta*  
 Wing, *Bompus*  
 Wing, *Buprestis*  
 Wing, *Calepteryx*  
 Wing, *Cercopis*  
 Wing, *Chrysis*  
 Wing, Cicada  
 Wing, Cimex  
 Wing, Copper Butterfly  
 Wing, *Corixa*  
 Wing, *Cydnus*  
 Wing, *Cynips*  
 Wing, Earwig  
 Wing, Egger Moth  
 Wing, Emperor Moth  
 Wing, *Ephemera* marg.  
 Wing, Field Cimex  
 Wing, fringed, Gnat  
 Wing, Grasshopper  
 Wing, *Grillus cristatus*,  
 Pupa  
 Wing, *Hemerobius*  
 Wing, *Idephorus*  
 Wing, *Ichneumon*  
 Wing, Hornet  
 Wing, Lady-bird  
 Wing, Lantern Fly  
 Wing, *Leptocerus*  
 Wing, *Libellula*  
 Wing, *Libellula*, rudi-  
 ments of  
 Wing, Locust  
 Wing, Mantis  
 Wing, May Fly  
 Wing, Menelaus  
 Wing, Midge Fly  
 Wing, *Notonecta*

Wing, *Panorpa*  
 Wing, *Papilio Machaon*  
 Wing, *Papilio Paris*  
 Wing, *Parnassius*  
 Wing, *Phryganea*  
 Wing, Plumed Moth  
 Wing, Satin Moth  
 Wing, Silver Moth  
 Wing, Stag Beetle  
 Wing, *Tenthredo*  
 Wing, *Thaïs Cerisyi*  
 Wing, Tiger Moth  
 Wing, Tortoise Moth  
 Wing, *Trichiosoma*  
 Wing, Tussock Moth  
 Wing, *Urania Leilus*  
 —  
 Wool fibre  
*Xanthidii* in flint

### Zoophytes.

#### GENERA.

*Acamarchias*  
*Actinia*  
*Aleyonella*  
*Aleyonium*  
*Antennularia*  
*Anthea*  
*Campanularia*  
*Cellaria*  
*Cellepora*  
*Cliona*  
*Crisia*  
*Cristatella*  
*Cydonium*  
*Discopora*  
*Eschara*  
*Farcimia*  
*Flustra*  
*Gorgonia*  
*Hydra*

*Laomedea*  
*Lepralia*  
*Lucernaria*  
*Madrepora*  
*Notamia*  
*Pennatula*  
*Plumatella*  
*Plumularia*  
*Retepora*  
*Sertularia*  
*Thoa*  
*Thuiaria*  
*Tubularia*  
*Tubulipora*  
*Turbinolia*  
*Valkeria*  
*Vesicularia*  
*Virgularia*

### VEGETABLE.

#### Organs.

##### A. Simple.

##### 1. Cellular Tissue.

*Calycanthus floridus*  
 Elder Pith  
*Eschynomena paludosa*  
 (Rice Paper)  
 Mistleto  
 Nelumbium  
 Papyrus, Petiole  
 Plane-tree  
*Rubus odoratus*  
 White Lily, sec. Leaf  
 —  
 Cotton, African  
 Cotton, American  
 Cotton, raw  
 Cotton, S. Sea Islands  
 Cotton, Surat

Gun Cotton

—

*Fibro-cellular.*

Sphagnum squamosum

*Membrane with fibre.*

Maurandia Barclayana

*Membrane without fibre.*

Casuarina

Clary, Purple-topped

Collomia grandifolia

Collomia linearis

Jungermannia, Elaters

*2. Vascular Tissue.*

*a. Spiral vessels simple.*

Anagallis, Petal

Asparagus

Dogwood, young branch

Elder

Ficus elastica

Hyacinth, Root

Rhubarb, Petiole

Spinage

Strawberry, Petiole

Tradescantia virginica

*b. Spiral vessels compound.*

Amadou (South American  
Tinder)

Australian Fern

Banana

Nepenthes

*c. Annular ducts.*

Impatiens balsamina

*d. Reticulated ducts.*

Carrot

*e. Dotted ducts.*

Cane

Spinage

*3. Woody Fibre simple.*

Flax, Irish

Flax, New Zealand

Flax, prepared without  
maceration

Hemp

Linen

*Woody Fibre glandular.*

Araucaria

Ephedra

Pinus Strobis

Yew-tree

*Raphides.*

Aloe

Cactus

Hyacinth

*B. Compound.*

*Cuticles.*

Aconitum neomontanum

Agave Americana

Aloe viscosa

Aucuba Japonica

Australian Fern

Cactus Opuntia

Caladium esculentum

Coffea Arabica

Crinum amabile

Croton variegatum

Cussonia thyrsoiflora

Dianthus caryophyllus

Gardenia latifolia

Hedera Helix

Helleborus foetidus

Hoya carnosa

Iberis umbellata

Lactuca quercina

Laurus Canariensis

Leontodon Taraxacum

Ligustrum vulgare

Lilium candidum

Marchantia polymorpha

Nerium Oleander

Oncidium altissimum

Poa trivialis

Primula vulgaris

Ribes rubrum

Rumex acetosa

Solanum tomentosum

Strobilanthes Sabinian.

Syringa vulgaris

Viola carnina

Viola odorata

Yucca gloriosa

Zea Mays

**Flours.**

Barley

Maize

Mustard

Oat

Pepper

Rye

Spice

Wheat

**Hairs.**

H. Althæa

H. Anchusa angustifolia

H. Borago officinalis

H. Capsella

H. Cibotium

H. Deutzia scabra

H. Dolichos (Cowage)

H. Dorstenia

H. Elæagnus angustifolia

H. Gesnera tubiflora

H. Gossypium

H. Hibiscus

H. Hieracium undulatum

H. Malpighia

H. Mathiola incana





H. *Primula Sinensis*H. *Verbascum*

Thistle Down

*Oil Cells.*

Currant, Black

Sage

**Pollen.**P. *Acacia lophantha*P. *Anagallis*P. *Arbutus*

P. Blue Bell

P. *Calla Æthiopica*P. *Campanula*

P. Canterbury Bell

P. *Cineraria maritima*P. *Circea Lutetiana*

P. Clover

P. *Convolvulus*P. *Coreopsis lanceolatus*P. *Digitalis purpurea*P. *Elymus sabulosus*

P. Evening Primrose

P. Flag, garden

P. *Fuchsia coccinea*P. *Fuchsia globosa*P. *Geranium sanguin.*

P. Grass

P. Guernsey Lily

P. *Heracleum Sibiricum*

P. Hollyhock

P. *Iresine diffusa*P. Ivy-leaf *Ipomœa*

P. Jasmine

P. Larkspur

P. Lily, Yellow Flag

P. Lime-tree

P. Lupin, garden

P. *Lychnis Flos Jovis*P. *Lychnis, Scarlet*

P. Mallow, garden

P. *Malope trifida*

P. Marvel of Peru

P. Marigold, African

P. Mignonette

P. Moth Mullein

P. Nettle

P. Oat Grass

P. Orange Flower

P. Orchis

P. *Pancratium declin.*P. *Polygonum, large gar-*  
den

P. Poppy, White

P. Rose Leadwort

P. Sage, Scarlet

P. *Salvia interrupta*P. *Saponaria officinalis*P. *Scirpus mucronatus*P. *Sedum acre*P. *Solanum dulce*

P. Spiny Milkwort

P. *Stachytarpheta mut.*

P. Strawberry

P. Sunflower

P. *Symphytum officinale*

P. Thrift, Bundled

P. Tiger Lily

P. Tulip

P. Viper's Grass, Rayed

P. *Viola tricolor*

P. Water Soldier

**Algæ.***Annularia (Ring-weed).**Bombycina (Silk-weed).**Calothrix (Hair-like).**Catenaria (Chain-weed)**Cervina (Horn-weed)**Chara**Claudia elegans*

Conferva

*Diatoma (Jointed-weed)**Echinocla (Bristly-weed)**Exilaria (Slender-weed)**Flabellaria (Fan-weed)**Fragillaria (Brittle-weed)**Fucus (Sea-weed)**Gomphonema (Club-weed)**Meloseira (Bead-like**Chain)**Nitella**Nodularia (Knob-weed)**Oscillatoria**Plumarium (Feather-*  
*weed)**Ulva**Zygnema (Jointed in*  
*pairs)***Ashes.***Calamus rudentum*

Coal

*Cornus alba, Leaf**Equisetum**Iris, Leaf**Oat, Husk**Spongia lacustris**Wheat, Husk*

---

**Active Molecules.**

Gamboge

Petrified Wood

---

Pure Carmine

Pure Indigo

Pure Sap Green

The above are useful for feeding  
animalcules.

**Bituminous.**

Coal; Benkar, Linlithg.  
 Coal, Bovey  
 Coal, Cannel; Arariston  
 Coal, Cannel; Staffs.  
 Coal, Craigleith  
 Coal, Devonshire Brown  
 Coal; Edmiston by Edin.  
 Coal; Hessia—t.s. and l.s.  
 Coal; Newbottle, Dalkeith  
 Coal, Newcastle  
 Coal, Newcastle, with spiral vessels  
 Coal; Redding, Linlithg.  
 Coal; Surturbrand, Iceland  
 Coal; Wellwood, Fife  
 Jet, Whitby  
 Lignite, Newbottle  
 Lignite, Surturbrand

**Charcoal.**

Alder  
 Box-wood  
 Chestnut

**Ferns.**

Acrostichum aureum  
 Allantodia —?—  
 Allantodia umbrosa  
 Alsophila aspera  
 Alsophila lunulata  
 Anemia fraxinifolia  
 Aspidium aculeatum  
 Aspidium auriculatum  
 Aspidium exaltatum  
 Asplenium ambiguum  
 Balantium Calcita  
 Cibotium Billardieri  
 Cyathea Jamaicae  
 Davallia paxitata  
 Doodia aspera

Gymnogramma  
 Lomaria aurea, *E. I.*  
 Lomaria Patersonia  
 Lygodium hirsutum  
 Lygodium scandens  
 Lygodium volubilis  
 Meniscium palustre  
 Nephrolepis —?—  
 Notholaena —?—  
 Polypodium phantagin.  
 Pteris Cretica  
 Pteris elegans  
 Pteris hastata  
 Sphaeropteris —?—  
 Struthiopteris Germanica  
 Todea Africana

**Fossils.**

Anabathra pulcherrima  
 Chara Seeds  
 Cocoa-fruit Tree  
 Coniferæ  
 Cycas revoluta  
 Fern  
 Fibres, Wood  
 Lepidodendron Harcourtii  
 Lepidodendron punctatum  
 Palm  
 Palm, Root  
 Peuce Eggensis  
 Peuce Huttonii  
 Peuce Lindlei  
 Pinites ambiguus  
 Pinites carbonaceus  
 Pinites medullaris  
 Pinites Withami  
 Pitus antiqua  
 Pitus prinæva  
 Psarolite  
 Sigillaria

**Fungi.**

Agaricus  
 Ascobolus  
 Calocera  
 Cryptomyces  
 Lycoperdon (*Puff-ball*)  
 Polyporus  
 Vermicularia

**Grasses, &c.**

Fescue  
 Meadow-grass  
 Wheat  
 ———  
 Stellaria media

**Lichens.**

Calicium (*Cup-shape*)  
 Gyrophora  
 Lecanora (*Basin-shape*)  
 Lecidea (*Saucer-shape*)  
 Lichen  
 Lycopodium  
 Peltidea (*Target-shape*)  
 Spiloma (*Spotted*)  
 Thelotrema  
 Urceolaria

**Mosses.**

Andræa  
 Anictangium  
 Anomodon  
 Anthoceros  
 Bartramia  
 Bryum  
 Buxbaumia  
 Cinclidotus  
 Conostomum  
 Daltonia  
 Dicranum  
 Didymodon  
 Diphyscium







Encalypta  
 Fontinalis  
 Funaria  
 Glyphomitrium  
 Grimmia  
 Gymnostomum  
 Hookeria  
 Hypnum  
 Jungermannia  
 Leaf Moss  
 Leucodon  
 Marchantia  
 Neckera  
 Orthotrichum  
 Phascum  
 Polytrichum  
 Pterogonium  
 Riccia  
 Schistostega  
 Sphærocarpus  
 Splachnum  
 Sphagnum (*Bog-Moss*)  
 Targionia  
 Tetraxis  
 Timmia  
 Tortula  
 Trichostomum  
 Weissia  
 Zygodon

**Petals.**

Pet. Anagallis  
 Pet. Geranium

**Seeds.**

S. Anagallis  
 S. Anethum aromatica  
 S. Argemone grandiflora  
 S. Bidens nivea  
 S. Catasetum  
 S. Catchfly, Lobel's

S. Clover  
 S. Collomia grandiflora  
 S. Coreopsis tinctoria  
 S. Dandelion (*Leontodon*)  
 S. Eceremocarpus  
 S. Epidodendron  
 S. Galinsogea parviflora  
 S. Groundsel  
 S. Gynadenia conopsea  
 S. Hypericum quadrang.  
 S. Hyssop, Common  
 S. Leontodon hirsuta  
 S. Lupinus  
 S. Lychnis, Dwarf  
 S. Lychnis, Scarlet  
 S. Marigold, French  
 S. Mignonette  
 S. Nicotiana Langsdorfii  
 S. Ophrys apifera  
 S. Orchis, Demerara  
 S. Orchis bifolia  
 S. Orchis maculata  
 S. Orchis pyramidalis  
 S. Poppy  
 S. Sorrel  
 S. Sycamore-tree  
 S. Stellaria holostea  
 S. Tobacco (*Nicotiana*)  
 S. Verbena nervosa  
 S. Zygotetalon Mackaii

**Spores.**

Sp. Anemia?  
 Sp. Fern, Australian  
 Sp. Lycopodium apothic.  
 Sp. Nephrodium Lonchitis

**Starch.**

Arrowroot Starch  
 Arrowroot (E. I.) Starch

Arrowroot (Portland)  
 Arrowroot (Tahiti) Starch  
 Arrowroot (W. I.) Starch  
 Lichenin Starch  
 Potato Starch  
 Rice Starch  
 Sago-meal Starch  
 Tapioca Starch  
 Tous les Mois (Canna)  
 Wheat Starch

**Woods.**

(*Thin Sections.*)

Acacia Catechu  
 Acacia fragrans  
 Acrocomia aculeata  
 Agave Americana  
 Agrimony  
 Alder  
 Althæa (Marsh Mallow)  
 Amaranth  
 Angelica  
 Apple-tree  
 Apricot  
 Araucaria spiralis  
 Areca triandra  
 Artichoke  
 Ash-tree  
 Aspen  
 Aster  
 Balantium Culcita  
 Bambusa  
 Banksia  
 Bay-tree  
 Beech-wood  
 Begonia  
 Birch  
 Bread-fruit Tree (African Palm)  
 Briar  
 Bromelia Pinguin

|                     |                            |                      |
|---------------------|----------------------------|----------------------|
| Buckbean            | Deal, Yellow               | Latania Borbonica    |
| Buckthorn           | Dichorizandra              | Latania rubra        |
| Bulrush             | Didymochlæna               | Laurel, Portugal     |
| Burdock             | Dock, Red                  | Laurestine           |
| Burmese Tree        | Dog-thorn, W. I.           | Lavender             |
| Cabbage-stalk       | Dogwood, American          | Leaf, Date           |
| Cactus              | Doryanthes excelsa         | Leaf, Palm           |
| Campanula           | Egg Plant                  | Lemon                |
| Cane, Bamboo        | Elder                      | Licuala spinosa      |
| Cane, Wanghie ?     | Elm-wood                   | Lilac                |
| Casuarina           | Epidendrum elongatum       | Lime-tree            |
| Catalpa             | Eryngo                     | Magnolia grandiflora |
| Cedar, White        | Euonymus tingens           | Mahogany             |
| Celtis orientalis   | Fennel                     | Mallow               |
| Centaurea           | Fig                        | Mandrake             |
| Chamædorea gracilis | Filbert-tree               | Mango-tree           |
| Chamærops elegans   | Fir, Norway Spruce         | Maple                |
| Chel Shul, Himal.   | Fleur de Lis               | Medlar               |
| Chel Shul, S.S.     | Flowering-stem, Leek       | Monk's-hood          |
| Chenopodium         | Flower-stalk, Aloe         | Mugwort              |
| Cherry-tree         | Furcæa vivipara            | Mulberry             |
| Chestnut, Horse     | Fustic                     | Mustard, Field       |
| Chestnut, Spanish   | Ghoolany, Himalaya         | Nepenthes distillata |
| China Aster         | Gooseberry                 | Nightshade           |
| Chrysanthemum       | Guelder Rose               | Oak, American        |
| Cinnamon-tree       | Helianthus                 | Oak, English         |
| Cisampelos          | Hemlock                    | Oak, Evergreen       |
| Clematis, R.        | Hickory                    | Oak, Irish           |
| Cocoanut-tree       | Holly                      | Oak, Norway          |
| Cork                | Hollbollia latifolia       | Oreodoxa regia       |
| Cornus sanguinea    | Hollyhock                  | Osmunda regalis      |
| Corn, Indian        | Ivy, Irish                 | Palma Christi        |
| Corypha Australis   | Jaca-tree                  | Parah-wood, Brazil   |
| Crinum amabile      | Jasmine                    | Parcira brava        |
| Cyeas revoluta      | Kashmull, E. I.            | Parsley              |
| Cypress, American   | Khebro, Lebanon            | Parsnip              |
| Cynara              | Kheton Pine                | Pear-tree            |
| Dahlia              | Laburnum                   | Peristeria elata     |
| Deal, Swiss         | Lagetta, or Lace-bark tree | Phœnix dactylifera   |
| Deal, White         | Larch                      | Phœnix paludosa      |





|                         |                           |                               |
|-------------------------|---------------------------|-------------------------------|
| Phytelephas             | Sarsaparilla              | Wormwood                      |
| Phytocrene              | Solah, E. I.              | Xanthoxylum                   |
| Pine, Norfolk Island    | Solomon's Seal            | Yew-wood                      |
| Pine, Weymouth          | Sorrel                    | Yucca                         |
| Pineapple               | Stalk, Carrot             | <b>Woods, Fossil.</b>         |
| Plane-tree              | Stalk, Fern               | <i>Localities were found.</i> |
| Plantain, Oriental      | Stalk, Melon              | Allen Bank                    |
| Plum-tree               | Stalk, Potato             | Allerley                      |
| Poplar                  | Stem, Dock-leaf           | Antigua                       |
| Prince's Feather        | Stem, Gourd               | Assam, E. I.                  |
| Privet                  | Stem, Sunflower           | Australia                     |
| Raspberry               | Straw                     | Autun, France                 |
| Rattan                  | Sugar-cane, E. I.         | Aya, E. I.                    |
| Reed, Indian            | Sumach                    | Ceylon                        |
| Reed, Portugal          | Sycamore                  | Craigleith                    |
| Rhododendron            | Synera                    | Gateshead                     |
| Rhubarb, Petiole        | Tacamahaca                | High Heworth                  |
| Root, Aloe              | Tamarind-tree             | Honduras                      |
| Root, Beech             | Teak                      | Illinois, Ohio                |
| Root, Chenopodium       | Testudinaria elephantipes | Lenel Braes                   |
| Root, China Aster       | Thaya orientalis          | Loch Lomond                   |
| Root, Dandelion         | Thistle                   | New Holland                   |
| Root, Fern              | Thorn, Black              | Palermo                       |
| Root, Hazel             | Thorn, White              | Paramatta                     |
| Root, Hornbeam          | Thurclah, E. I.           | Rose Garland, V. D. L.        |
| Root, Horseradish       | Tobacco                   | St. Bartholomew, E. I.        |
| Root, Nettle            | Todea Africana            | Scarborough                   |
| Root, Phytolacca        | Tulip-tree                | Sidney, N. S.W.               |
| Root, Savin             | Turbeth, Indian           | Tweed Mill                    |
| Root, Teasel            | Uvularia Chincensis       | Ushaw                         |
| Root, Vine              | Viburnum Lantana          | Van Diemen's Land             |
| Rose, Dog               | Vine, Grape               | West Indies                   |
| Rose-wood               | Vine, Indian              | <b>Organic Fabrics.</b>       |
| Ruscus aculeata         | Wallichia caryotoides     | Blonde                        |
| Rush                    | Walnut-tree               | Calico                        |
| Sabal palmetta          | Wampee-tree               | Cambrie                       |
| Saccharum officinarum   | Water Flag                | Challis                       |
| Sagus Ruffia            | Wild Turnip               | Cloth                         |
| Salisburia adiantifolia | Willow                    | Crape                         |
| Sallow                  | Winteria aromatica        |                               |

Diaper  
 Gauze  
 Gros de Naples  
 Lace, Machine  
 Lace, Pillow  
 Lawn  
 Leno  
 Linen  
 Merino  
 Mousseline de Laine  
 Mummy Cloth, Egyptian,  
 (Linen)  
 Mummy Cloth, Peruvian,  
 (Cotton)  
 Muslin  
 Net  
 New Zealand Cloth  
 Oriental  
 Ribbon  
 Sarsenet  
 Silk, Figured  
 Silk, Shot  
 Stuffs, Twilled  
 Velvet, Terry

Asbestos  
 Avanturine?  
 Barytes Sulphate, Sta-  
 lactite, th. s.  
 Bismuth, Crystallized  
 Blend Antimony  
 Blend Zinc  
 Boracic Acid, Native  
 Bronze  
 Calamine, Sparry  
 Calcedony  
 Camphor, Precipitated  
 Chalk  
 Chert, th. s.  
 Cinnabar  
 Cobalt Pyrites  
 Concretions, Carbonate  
 Lime  
 Copper, Electrotpe  
 Copper Pyrites  
 Copper Sand

**Crystals.**

C. Acetate of Lead  
 C. Alum  
 C. Ammonia, Hydrochlo-  
 rate  
 C. Antimony  
 C. Borax  
 C. Caffein (Coffee)  
 C. Citric Acid  
 C. Gold  
 C. Lupulin (Hop)  
 C. Nitre  
 C. Oxalic Acid  
 C. Quinine, Bi-sulphate  
 C. Rochelle Salt  
 C. Silver  
 C. Soda  
 C. Sugar

—

Deut-Ioduret of Mercury

Derbyshire Spar  
 Diamond, Crystal  
 Emerald, Prismatic  
 Felspar, Prismatic  
 Foliated Limestone  
 Garnet Sand  
 Gold Leaf  
 Graphite, Scaly  
 Granite, fragments  
 Green Sand  
 Helvine  
 Hydrate Silica  
 Hyperstene  
 Ice  
 Iceland Spar  
 Ioduret Lead  
 Iron, Meteoric  
 Iron Ore, Specular  
 Iron Ore (Elba)  
 Iron Pyrites, Prismatic

**Iron and Steel.**

Iron, Cast  
 Iron, Wrought  
 Steel, Cast  
 Steel, Shear

—

Jasper, Striped  
 Lapis Lazuli  
 Lead Spar, Red  
 Magnesian Limestone  
 Malachite, Fibrous  
 Mica, Cebalt  
 Mica, Copper  
 Mica, Iron  
 Mica, Pearl  
 Micaceous Sand  
 Minerals, fragments  
 Mocha Stone  
 Molybdate of Lead  
 Mountain-Rock Cork

**INORGANIC.**

Aërolite, th.s.  
 African Sand?  
 Agate, Moss  
 Agate, Striated  
 Amber  
 Amethyst, Compound  
 Crystal, t.s.  
 Amethyst, Fibrous  
 Amethyst with fluid  
 Amianthus  
 Antimony Needle  
 Antimony Ore, Red  
 Antimony, Sulphuret  
 Arsenic, Native







Muriate of Copper  
 Native Copper  
 Native Gold  
 Native Iron  
 Native Minium  
 Native Nickel  
 Native Platina  
 Native Silver  
 Native Tellurium  
 Needle Zeolite  
 Nitrate of Silver  
 Olivinite, Diprismatic

### Oolites,

(*Thin Sections.*)

O. Bath  
 O. Caen, Normandy  
 O. Germany  
 O. Hartz Mountains  
 O. Ketton  
 O. Netley Abbey  
 O. Portland  
 O. Siberia  
 O. South Wales  
 O. Yorkshire  
 ———  
 Opal Wood  
 Ore, Chrome  
 Ore, Manganese  
 Ore, Titanium  
 Ore, Uranium  
 Orpiment, Red  
 Orpiment, Yellow  
 Pearl Sand  
 Pearl Spar  
 Peacock Copper  
 Pebble, Brighton, t.s.  
 Phosphate of Copper  
 Phosphate of Lead  
 Potash, Ferro-prussiate

Pyrites  
 Quartz with fluid  
 Red Silver  
 Red Zinc  
 Roestone  
 Ruby, Crystal  
 Ruby, Copper  
 Sandstone  
 Sapphire, Crystal  
 Sarde  
 Scapolite, Foliated  
 Serpentine  
 Silica, Fibres of  
 Silver, Daguerreotype  
 Silver Ore  
 Silver, Muriate  
 Snow, Crystals  
 Steatite (*Soap-stone*)  
 Sulphur, Sublimed  
 Sulphate, Cobalt  
 Tabisheer  
 Tale, Indurated  
 Tin, Crystallized  
 Tin Ore  
 Topaz with fluid  
 Tourmaline  
 Tremolite, Glassy  
 Uran Mica (*Uranite*)  
 Uranium, New Salt  
 Uranium, Green  
 Uranium, Yellow  
 Uric Acid  
 Wavellite  
 Zeolite, Fibrous  
 Zinc, Crystallized  
 Zircon

*Crystals and Minerals  
 for Polarizing Micro-  
 scope.*

Acetate Copper, Dichrom.

Ammonia Purpurate  
 Agate  
 Amethyst  
 Bichlorate Mercury  
 Bisulphate Potassa  
 Borate Soda  
 Borax & Phosph. Acid  
 Carbazotate Potassa  
 Chlorate Potassa  
 Chromate Potash  
 Ferroc. Potassium  
 Lithic Acid  
 Mica  
 Morphia  
 Nitre in Gum, Analyt.  
 Oxalate Ammonia  
 Oxalate Chrome & Potash  
 Dichrom.  
 Perchloride Mercury  
 Prussiate Potassa  
 Salicine  
 Selenite  
 Sulphate Cadmium  
 Sulphate Copper  
 Sulphate Magnesia  
 Sulphate Potassa  
 Sulphate Zinc  
 Tartaric Acid  
 Tremolite  
 Xanthate Ammonia  
 Zeolite, Fibrous

### Works of Art.

Berlin Steel Work  
 Coins, small  
 Engravings, minute print  
 Engravings, Sculpture  
 Iris Button  
 Needle Eye  
 Watch Chain

# MICROSCOPIC OBJECTS,

&c. &c.

---

## CHAPTER I.

### NOTES ON THE RECENT IMPROVEMENTS IN MICROSCOPES.

---

“The Divine laws work on the minutest and the grandest scale indifferently; in fact, there is no such thing as great and small in nature, but world spaces are as a hair-breadth, and a thousand years as one day.”—*Explanations, Vestiges of Creation*, p. 6.

---

So rapid have been the discoveries by the Achromatic Microscope, that no treatise on animal or vegetable physiology of twenty years' standing can be depended upon as containing a correct account of organic structures. It is therefore unnecessary to offer any remarks on the utility of that instrument. A few details relating to the causes which led to the modern improvements in the Microscope, and the consequent discoveries in science, may, however, be introduced here with advantage.

About the year 1757 the refracting telescope was made achromatic by the introduction of a concave lens of flint glass, to correct the errors arising from the

form of, and the refrangibility produced by, the object-glass. This invention constituted a new era in astronomical science. Indeed so great was the progress of astronomy in consequence, that the question would naturally suggest itself, "Why do not opticians apply the achromatic construction to the microscope? Surely similar results in other sciences might be expected." Whereas it was not effectively applied to the microscope until the year 1824. This enigma it is now proposed to solve.

Soon after the achromatic telescope was perfected, Benjamin Martin and others actually made achromatic object-glasses for microscopes; but these lenses failed to produce any improvement. Similar trials were made, and results obtained, from that time to the year 1815, when Professor Amici, then of Modena, published an account of his improvements in microscopes. These improvements were made both on the refracting and reflecting kinds; the former of which he made achromatic: he then abandoned it, and devoted his superior talents to perfecting the reflecting microscope. This is sufficient to show the relative estimation in which he held those constructions. About the year 1824, MM. Selligie and Vincent and Charles Chevalier, in France, constructed achromatic microscopes. One of these instruments, by the latter artist, was sent to England, and was examined by a celebrated optician here, who stated that it was of first-rate workmanship, but in performance did not surpass that of a good compound microscope when well made. In the same year,

Dr. Goring employed the late Mr. W. Tulley to make him an achromatic object-glass for his microscope, and consulted thereon the father of that artist, the celebrated Charles Tulley; who gave it as his opinion that the time and money bestowed upon the attempt would be wasted. Notwithstanding this, Dr. Goring, with signal liberality, engaged Mr. Tulley on the work.

Though such was the opinion of the first optician of the day, so little was the subject understood, that at the time Dr. Goring was engaged with this achromatic, on his mentioning the circumstance to a friend who had made important mathematical investigations in optical matters, and who now occupies a place in the first rank of science, the reply he received was, "I thought all the best compound microscopes were achromatic" !

While this attempt was in progress, (for it occupied some months, Mr. Tulley working in the day and Dr. Goring trying them by night,) Dr. G. discovered that the structure of certain bodies could be readily seen in some microscopes and not in others. These bodies he named *Test Objects*; a full account of which will be found in this work. Dr. Goring determined to try the new achromatic on these *tests*; and was then led to the all-important discovery, that *the penetrating power of a microscope depends upon its angle-of-aperture*. This explained the cause of all the former failures. It also clearly indicated the right direction in which improvements would result. From this time the superiority of the achromatic construction over the ordinary compound,

and indeed all other constructions of the compound, was manifest. It may be remarked, that Dr. Goring had tried Euler's proposal of reducing the aberrations by combining two plano-convex lenses for the object-glass, and also Herschel's combinations for producing a minimum of aberrations, from his investigations published in the Philosophical Transactions for 1821.

About the same time (1825) Mr. Lister procured an achromatic microscope from Paris, and placed it in the hands of Dr. Goring for trial. Both these gentlemen were at first disappointed with the performance of this instrument; but when Dr. Goring had increased the angle-of-aperture of the object-glasses, by enlarging the small diaphragm or stop behind them, the performance was greatly improved, and its achromatism (which, owing to the thinness of the pairs of lenses, had been doubted,) clearly established.

These improvements were communicated to the scientific world in the Journal of the Royal Institution; and in 1829, Dr. Goring gave the public a practical and detailed account of the results in the '*Microscopic Illustrations.*'\* All subsequent improvements in the achromatic microscope are merely further developments of the same plan, or, in other words, further progress along the same road.

It may now be proper to offer to the reader a few

\* A Third Edition of this work, with a Supplement, has been published since Dr. Goring's death.

remarks on Angular Aperture. Sir William Herschel discovered that the space-penetrating power of a telescope depends upon the diameter of its object-glass or speculum. Hence arises the power of a telescope to exhibit to us celestial objects which the unassisted eye cannot perceive. This power is distinct from magnifying power, though associated with it; in the same manner as the strength of a beam is not necessarily in proportion to its weight, though we cannot have a beam without some weight. Different materials of the same weight may have different degrees of strength. The penetrating power arises from the number of rays of light from a given object, which are condensed on the retina of the eye. Suppose that the pupil or aperture of the human eye be one eighth of an inch in diameter, and the object-glass or metal of a telescope be eight inches, the proportional diameters of the eye and telescope will be as 1 to 64. Now as the areas (surfaces) of circles are to each other as their squares, it follows that for every pencil of rays which enters the eye, 4096 will be received by the telescope. Now, if the celestial object be so distant that fewer pencils of rays than those received by the telescope are too faint to give an impression on the eye, in such a case a star would be seen in the instrument while it would be invisible to the eye. The same observations apply to the microscope; and the superiority of the modern improvements on that instrument does not arise from increased magnifying power, but an augmentation of penetration; indeed, in comparing two microscopes of

equal penetration, that which has the *lowest* magnifying power is the best.

If the penetrating power of a microscope could be as easily determined as that of a telescope, there would be no difficulty in the matter ; a simple measurement of the diameter would be sufficient. But such is not the case ; the penetration in the microscope is as the angle-of-aperture. Thus, suppose the aperture be 10 degrees ; if the diameter be kept the same and the focal length of the lenses reduced to one half, the angular aperture will be nearly doubled.

A full account of angular aperture, with a list of its amount obtained by lenses of different foci, will be found in the Third Edition of the 'Microscopic Illustrations.'

It is proper to state, that about the period of the fabrication of the first achromatic object-glass for a microscope, by Dr. Goring, scientific men in all parts of Europe were engaged in improvements on that instrument ; but all their talents and energies were directed to other parts of the microscope. High magnifying power and a large flat field of view appear to have been their chief aim. In Scotland, the Royal Society of Edinburgh had a microscope constructed between twenty and thirty feet in length ; but did not apply achromatic object-glasses : it follows, therefore, that the Council did not deem them of consequence. In Germany, the experimenters approached nearly the right direction ; for they strung five or six object-glasses together ; but their



aim was magnifying power, not penetration,—not a word was said of the latter. At Cambridge, laborious analytical investigations were made on the best construction of the eye-piece. So far, however, were these eminent mathematicians from the right course, that even after effective achromatic object-glasses were executed, they gave the optician an elaborate paper for constructing in a simple manner a microscope that, as a whole, should be achromatic; the only objection to which construction was, that by it no penetrating power of any amount could be obtained. Hence in a short time this construction was abandoned, and that of the achromatic object-glasses with larger angular aperture, combined with a modification of the Huyghenian eye-piece, is now permanently established.

To enumerate the various applications of the microscope to science is unnecessary in this work, as the subsequent chapters will show. One use, however, may be mentioned, as, *à priori*, it would not have been expected, namely, its value to the geologist. It has been well said by Mr. Witham, in his work on Fossil Vegetables, that the ancient fossils of our earth are its “*medals*, recording changes which it has undergone, and placing before our eyes innumerable specimens of nature’s early productions. The study of the wonders of creative power,” he continues, “so profusely scattered wherever we cast our eyes, is calculated to improve the tone of public feeling, by turning into channels of useful inquiry the natural

activity of the human mind, to elevate and enlarge our conceptions, and to soften and improve our affections. The study of fossils in particular carries back our thoughts to a time when the British Isles had no place, in their present form, on the map of the world, and when land and sea, mountains and rivers, valleys and plains, continents and oceans, must have been arranged in a way entirely different from what we now behold. While their extreme antiquity commands our veneration, their immense numbers and inconceivable variety and beauty impress us with sentiments of wonder and gratitude at so great and so marvellous a design."

## CHAPTER II.

### GENERAL OBSERVATIONS ON THE CATALOGUE OF MICROSCOPIC OBJECTS.

ANIMAL.—Under this head are comprised objects obtained from the animal kingdom, whether recent or fossil, including the Corallines, Sponges, and Zoophytes. In general, the names are placed alphabetically; but where there is a considerable number of one kind, they are placed under separate heads. These divisions are not intended as systematic, but rather as illustrative of different forms of organization for effecting similar purposes. Thus, under the head of FEET are included those not only of Insects, but of Arachnida, &c. The same remark will apply to the other divisions.

It must be borne in mind that this little work is not intended to instruct the entomologist in the *arrangement* or *technicalities* of his science, nor the botanist in the character of plants. But the general observer of nature, in every department, will find fragments of materials scattered throughout, that, it is believed, will assist him in any branch of natural science that he may be disposed to cultivate.

*Acari*.—This small tribe of creatures has not only furnished employment to the microscopist of olden times, when examining a morsel of decayed cheese, but of late years has afforded an important subject for discussion; the animals supposed by Mr. Crosse to be producible by galvanic agency being a species of this genus. When carefully examined, their structure is seen to be very different from that of insects. Among the most curious is a species which infests the Dung Beetle, found among the small heaps of manure left by cattle in fields. These beetles have hard smooth polished corslets and elytra; and the small *Acarus* found in the folds between the head and the body (for beetles are said to have no neck) is provided with a very curious appendage to each of its feet, by which it can produce a vacuum, and thus with ease move about on the polished surface of the beetle. To examine the structure of the foot, place under the microscope a few *Acari* in an aquatic box, with a magnifying power of about 80 diameters, when the action of this suction apparatus may be readily observed as the creatures crawl upon the glass of the live-box.

*Àërating Leaflets of the Larva of the Libellula*.—These beautiful microscopic objects are the tails of the aquatic larva above named, and when mounted in Canada balsam are permanent objects. In shape they resemble the leaf of the laurel; and when examined under a power of 30 diameters, the two large tracheæ which run along the middle, and their numerous branches, are readily seen. With a magnifying power of 100 diameters, the spiral

nature of these air-tubes, together with the numerous openings in the membranes, are observable. A drawing of this larva (magnified) is published in the "*Notes on Natural History*," by Mr. Pritchard (Plate 3.) Of late years the species of *Libellula* possessing these leaflet-tails has become scarce about London.

*Anatomical Preparations.*—In the list, only a few interesting subjects are named: others will readily suggest themselves to persons engaged in such pursuits.

The medical student will find the *achromatic* microscope an important instrument in these researches; and since its cost has been so greatly reduced (see the concluding chapters) the difficulty of procuring its aid has been materially lessened. For the medical practitioner who desires to investigate the states of disease or the nature of urinary deposits, the vertical achromatic microscope is amply sufficient; and it will be found wise not to encumber himself with an unnecessary number of magnifiers. An object-glass of one third of an inch focus will in most cases be sufficient.

The subjects named in the list have their vessels injected with different-coloured substances. They are mounted as opaque objects under thin glasses about half an inch in diameter. To view them efficiently, the light should be condensed upon them, and the power used should be from 35 to 80 times, linear.

*Antennae.*—The horns of insects not only vary very much in form in different genera, but those of the male and female differ in the same species. In the Catalogue

will be found examples of the most curious kinds. They require a shallow magnifying power; from 30 to 70 diameters being generally sufficient.

*Aphis Vastator*.—This insect (the larva of which is supposed by some naturalists to be the cause of the disease in the potato) has of late attracted much attention. As a microscopic object it does not possess any remarkable features, except indeed the two air-tubuli near the posterior extremity of the body.

The interest and importance which attach to the potato, and the prevalence of disease to which it has lately been subjected, and through which a large portion of our population have been deprived of a valuable article of food, render it desirable that a few remarks should here be offered on this matter.

The subject of the diseased state of the potato has been deemed worthy the attention of the Government, who caused an investigation to be made into its nature and causes by eminently scientific men; besides which, many of our first botanists and microscopic observers have devoted all their talents and energies to the detection of the cause of the evil and to the discovery of means adapted for the prevention of its recurrence.

The writer of this is induced to believe that nearly all the examinations of these *savans* have been directed to the *effects*, rather than the *cause* of the disease in question. The result of this mistake has been that nearly all the recommendations of scientific men have proved wholly unavailing and useless.

The real cause of this disease it is proposed now to describe. Just before it made its first appearance much rain had fallen, which was succeeded by cold frosty nights. The effect of this weather upon the tuber of the potato would be in the first place to saturate with water and distend to the utmost the numerous cellules of which the tuber consists. Intensely cold nights succeeding, this water in the cellules would become frozen ; during which process it would expand, and the membrane inclosing it, having, as before said, previously become distended to the utmost, would burst ; and the death of the tuber would immediately result. This dead matter would then be in a fit state and situation for developing the growth of any fungi whose spores (seeds) might be present. Many species of fungi, it is well known, require but a few hours to pass through all their stages from sporules to maturity and the production of innumerable sporules from a single one. Hence there is no difficulty in accounting for the rapid progress of this disease.

It must be observed that the disease now found in the tuber was not the cause but the effect. The almost infinite number of spores of these fungi, which were during the first year produced, and which exist in every locality that has had a diseased potato in it, renders it difficult to plant potatoes in those situations without the nidus for the development of this fungus. It follows, therefore, that the only means for preventing the spread of this evil would be *to sow in new situations, in which the disease has never appeared, perfectly sound seed potatoes,*

*which have not been near any place in which diseased potatoes have been kept.*

That the above view is correct, microscopic observations on the tuber, and the following statement and remarks, will show.

Some years ago a friend of the writer went to reside in a new house in the suburbs of London. The house was remarkably dry, and he observed that remains of the paste he occasionally used for mounting drawings, and which was kept in a small jar in a cupboard, did not become mouldy. This surprised him very much; for at a former residence the paste would mildew on its surface if kept only a few days. On one occasion it so happened that a little paste was left in a cupboard for a great length of time; and on examination it appeared covered with mildew,—a circumstance which might naturally be expected.\* The curious fact which now presented itself was, that afterwards no paste could be kept in that house for any length of time without mildew being formed on its surface; thus proving that these minute spores were present in every part of the house, and, being wafted about by the slightest currents of air, were self-sown on the surface of fresh paste.

The case of the potato, there is little doubt, will be found to be a parallel one to that of the paste; and it

\* It may be remarked, that the mildew which forms upon the surface of paste consists of numerous plants, belonging to the family of Acrogens, called Fungi, and which are highly interesting microscopic objects.



will be vain to hope for the growth of sound potatoes, for some years, where diseased ones have previously existed, unless they be sown *entire*—which method, by planting in drills, would be not less productive—and thus the disease be *prevented*.

*Blood-discs.*—The red corpuscles in the blood of man are always of a circular form, and in their normal state are flattened discs without nuclei. If a drop of water be added to the blood, they become spherical by endosmose. In all air-breathing oviparous vertebrated animals, the blood-corpuscles are oval, and a nucleus may be observed within each of them. This nucleus is rendered very distinct by the addition of a drop of diluted acetic acid.—The superior size of the blood-discs in the *Siren lacertina* has enabled Professor Owen to make a minute examination of the contained nucleus. He has distinctly observed that the nucleus consists of a cluster of from 20 to 30 bright spherical nucleoli inclosed in a transparent capsule, in the centre of the oval-shaped flattened blood-disc. The length of the disc is  $\frac{1}{450}$ th of an inch; while the average diameter of that of human blood is  $\frac{1}{3000}$ th of an inch. The magnifying power of a microscope for the examination of these matters should range from 400 to 800 diameters. For preparing and measuring Blood-discs see ‘Micrographia.’

*Bone.*—For microscopic examination, bone should be cut into thin sections about  $\frac{1}{50}$ th of an inch in thickness, and mounted on glass slides. When animal tissues are consolidated by the deposition of earthy matter within

their cells and fibres, a hard solid substance is produced. In the shells of the Echinodermata the deposition of carbonate of lime in fibres, while in Mollusca it is found in cells. Sometimes the earthy matter crystallizes, as in the teeth; at other times it combines chemically with the gelatine of the cells, as in bone. This deposition in bone does not occur in all the cells, as the bone requires to grow and be nourished: hence arises its peculiarity of structure. Independently of the hollows, or cancelli, the hard part of the bone is traversed by canals called Haversian, which run in the direction of the laminae: these are connected together by transverse communications. In a thin transverse section of bone the solid matter may be observed arranged around the Haversian canals in concentric rows. Among these layers dark specks are dispersed. These dark specks (called *lacunæ*), when magnified about 200 diameters, are observed to be cavities of an irregular oval form, from which emanate numerous minute branch canals. These cavities appear dark, for the same reason as a minute air-bubble does in Canada balsam—namely, the great difference of refraction of the two media. By means of these branches (*canaliculi*), *lacunæ*, and Haversian canals, the bone is nourished with oily and other proper fluids.

According to the microscopic observations of Mr. Quekett, the form and size of these *lacunæ*, and the tortuosity of their *canaliculi*, vary in the bones of different kinds of animals; so that a microscopic examination of a minute fragment of bone is sufficient to enable the

naturalist to determine the class of animals to which it belongs. The magnifying powers required average from 100 to 300 diameters.

*Bone of Cuttlefish.*—A thin vertical section of this substance offers an interesting subject for study, showing the method adopted by the Creator for giving this animal the greatest amount of solidity with the least possible weight. The carbonate of lime and animal matter of which this substance is formed are deposited by the animal in plates, separated by thin vertical columns, arranged in a zigzag manner. To view the arrangement of the vertical columns to advantage, the object must be viewed by reflected light, and is prepared by taking off one of the plates without disturbing the columns, which by a little dexterity may be left attached to a lower plate. This subject therefore furnishes two objects, the one being prepared at right angles to the other.—Power 80 diameters. By polarized light the pillars in the vertical sections are distinctly seen; and for this purpose it may be mounted in Canada balsam.

*Bug.*—The *Cimex lectularius*, or Bed Bug, is a popular object for the microscope, and therefore must have a place here. When mounted in Canada balsam it becomes a permanent object, and when the specimen is perfect, with the rostrum, or beak, laid out, and the lancets separated, it becomes valuable. The spiracles, or breathing-openings, along each side of the body, are worthy of notice. The eggs have an operculum, or cover, and are interesting opaque objects. There are three other species

of the *Cimex*; one (*C. Hirundinis*) is met with in the nests of martins; another (*C. Columbarius*) infests pigeons; and the third (*C. Pipistrelli*) is a parasite of the Pipistrelli Bat. These three are figured by the Rev. L. Jenyns, in the *Annals of Natural History*, vol. iii.

*Centipede*.—This creature is well suited for shallow magnifiers, and becomes a permanent subject when mounted in Canada balsam. The arrangement of its respiratory system is worthy of minute examination. When alive it may be taken at night, as it emits a flash of light when suddenly approached.

*Coral*.—The mode of deposition of carbonate of lime by these Zoophytes can be readily seen by examination of thin sections; these should be cut in two directions—one transverse and the other parallel to the axis.—Magnifying power 50 diameters.

*Disc, Foot*.—This object, which is obtained from the leg of the male *Dytiscus*, is part of the suction apparatus by which that aquatic beetle seizes the female. When mounted in balsam as a transparent object, the strong radial fibres are distinctly seen.

*Dorsal Vessel of the Larva of the Ephemera*—is a very delicate preparation. It is supposed by some, from its pulsatory movements, to perform the function of a heart. The air tubes which surround it are composed of a membrane lined by a spiral fibre.

*Curculio*.—Many of the English species of this genus of beetles, when mounted entire, are magnificent subjects for the opaque microscope. The specimens should

be mounted when fresh and uninjured. The Oak Curculio in many respects surpasses in brilliancy the Brazilian Diamond Beetle. A magnifying power of 30 diameters is amply sufficient. The light of an Argand burner strongly condensed is essential to exhibit them with effect. Mirrors are better than lenses for condensing the light on these objects.

*Egg-shell.*—If a small piece of egg-shell be ground thin upon a hone, the inner side being left, the form of the *fibrin*, on which the earthy matter of the shell is deposited, may be readily observed. It resembles short fibres matted together. It sometimes happens that eggs are produced without the deposit of carbonate of lime; the envelope of these exhibits the fibrin to advantage.

*Eggs.*—The eggs of birds are oval, but those of insects assume a vast variety of forms; some are furnished with covers; the surfaces of many are elegantly embossed and fluted, whilst others, as those of the Bed Bug, have their surface curiously granulated. Those given in the Catalogue will be found among the most interesting for the microscope. They require in most cases to be viewed as opaque objects under a power of 30 to 60 diameters.

About seven years ago a gentleman in Norfolk discovered, on a small piece of red sandstone, a few white spots about the  $\frac{1}{30}$ th of an inch in diameter. On examining these as opaque objects with a power of 30 diameters, each appeared to have a white convex centre, with a sculptured margin; they were of a snow-white colour. Since then they have been mentioned by various observers,

and a description has been published, in which they are considered as a cryptogamous vegetable. There is little doubt, however, that they will prove to be the eggs of an insect. They are often met with among old buildings, attached to stones, in the crevices of slates, &c.

*The Elytra, or Wing-cases, of Insects* are often singularly engraved and coloured. Some (Curculiones) are covered with beautiful iridescent scales, and others are furnished with branched hairs. They are best seen by strong reflected light. A punctated form of elytron is seen in the Elaphrus beetles. The wing-covers of the *Cercopis sanguinolenta* are interesting transparent objects, mounted in balsam. The large elytra form good objects for the screen of the oxyhydrogen and solar microscopes.

The elytron of the Diamond Beetle is best viewed by the microscope when mounted in a cell filled with Canada balsam, and covered with a plate of glass. This method not only protects the scales upon the wing from dust and injury, but by rendering the refractions of the surface more uniform improves the vision.

*Entozoa*.—There are no less than fourteen distinct species of these creatures found in the human body. They are mostly inclosed in a long oval cyst, which is sometimes imbedded in the muscles. To unassisted vision the cysts appear as white specks about  $\frac{1}{20}$ th of an inch in length.

*Exuviae*.—Insects, spiders and many of the Entomostreaea, shed their skins several times during growth. These exuviae, or cast skins, being very transparent, afford

excellent objects for the examination of the exact forms of the parts to which they belonged. In general, they are too diaphanous for mounting in Canada balsam, though the exuviae of the jaws of the Spider may be displayed in this way with effect.

*Eyes, Fish.*—The dried globular crystalline lens in the eye of a Fish, when examined by the aid of a microscope, will be found to be composed of a number of concentric strata or layers, somewhat resembling the coats of an onion. A portion of one of these laminae, separated, and placed under a microscope, magnifying 300 diameters, will be found to consist of flat fibres or bands, arising from each pole of the lens and expanding towards its equator, like the spaces between the meridians on the artificial globe. The edges of these fibres are serrated, and fit into each other like the teeth of a double rack or the sutures of the human skull. Sir David Brewster, who first minutely examined the structure of these lenses, has accurately measured the breadth of the bands. (See Phil. Trans. for 1833.) He found that a single lens,  $\frac{1}{10}$ ths of an inch in diameter, from the eye of a codfish, contained five millions of these flat fibres, and 62,500 millions of serratures, or teeth. They are delightful objects, whether opaque or transparent.—Magnifying power for the former 250, and for the latter 350 diameters.

*Eyes, Insects, &c.*—The structure, number, and form of the eyes of insects may be ranked among the most curious parts of natural history. The compound eyes are arranged

in two groups, each composed of several distinct eyes, of quadrangular, hexangular, circular and other forms, each eye consisting of several layers of meniscus lenses, which are easily separated by maceration, and their focus measured in the same manner as minute lenses. If a cluster of the eyes be placed under the microscope, at a distance *without its focus* equal to their focal length, the lens of each eye will exhibit a distinct image of a candle flame, or other object placed before it, in the same manner as a telescope would do; indeed the whole becomes in fact an inverted telescope. To observe this effect the microscope should be horizontal, and no mirror or condenser should be used behind the object.

The number of eyes in a single group often amounts to thousands. The eyes of spiders are single; they have from four to twelve, variously arranged; those most particularly worthy of notice are given in the list. In addition to compound eyes, some insects have in front of their head three distinct single eyes.

The eyes of the Harlequin Beetle are best suited for the oxyhydrogen microscope, being large and well separated from each other. The eyes of the Crawfish are square, and show their optical character very readily.

*Feet, Insects.*—The structure of the feet of those insects which support themselves on polished surfaces, and against the force of gravity, is worthy of microscopic examination, and, like that of their eyes, is as yet but imperfectly understood. The viewing them as opaque objects, combined with observations on other specimens



mounted in Canada balsam, has tended greatly to assist us in discovering the real form of these members. The number of suction-pads to each foot is not constant; some flies have two, others have three, and in others they are altogether absent. The anterior and middle pairs of feet of the male *Dytiscus*, as before remarked, are furnished with curious disc- or cup-shaped appendages on the inside of the leg.—Magnifying power 30 to 100 diameters.

*Fossils.*—In several argillaceous strata and limestones minute shells may be readily discovered. The specimens should be cut into thin sections. Among the many important facts brought to light by the study of the contents of flints, limestones, &c. is the fact of their comparatively recent formation, it being clear that the animals, the remains of which they inclose, must have existed prior to the formation of those stones. Thin sections of the Brighton pebble are distinguished by inclosing curious egg-shaped bodies; these are figured in Pritchard's 'History of Infusoria,' plate 12. The flints from the chalk deposits are mostly silicified sponges, and usually contain minute organic remains similar to those found in recent sponges of the present time.—The magnifying powers for these examinations vary greatly, according to the nature of the fossil; average, 60 to 450 diameters.

*Hair of Animals, &c.*—By ordinary vision most hairs appear cylindrical; but by the assistance of the microscope great variety in their forms may be detected. When

immersed in Canada balsam, which fills up all their cavities, their appearance is most remarkably changed; indeed so great is the difference, that persons well acquainted with the microscopic appearance of the hair in one condition would not identify it in the other. The best example illustrative of this fact is the hair of the Wapiti Deer. To form an accurate notion of their real structure, they should be examined in both conditions, and also as opaque objects. A good microscopic investigation of the structure of hair is much wanted; the essay by M. Breschet entitled '*Nouvelle Recherches sur la Structure de la Peau*' may in the mean time be consulted with advantage. His engravings are good. The felting properties of hair are of vast importance in a manufacturing point of view. The best means of determining the relative value of different kinds of hair and wool for these purposes, is to submit them to the microscope either as opaque or transparent bodies; if the latter, *unmounted* in balsam, varnish, or gum.

The colour of the hair is dependent upon the matter contained within it, in the same manner as the colour of the human skin is dependent upon the pigmentum under it. Hairs that have become grey or white are found on microscopic examination to be empty tubes, the pigmentum having disappeared or its secretion ceased.

*Hair of the Bird-catching Spider (Mygale aviculare)* of South America, offers very great variety in structure. That taken from the palpi is branched, and towards the extremity the central stem enlarges, becomes fluted, and

assumes a bright orange colour. The use of this augmentation in bulk towards the end is not ascertained; but Mr. Pritchard remarks that “a similar structure on a large scale may be observed in the small feathers from the breast of the Indian Humming-bird, which latter afford interesting microscopic objects under moderate amplification.”

*Hair of the Larva of the Dermestes.*—This curious hair, as also those of the mouse, bat, &c., will be found described in the chapter on Test Objects.

*Human Hair.*—In the adult, the friction of the hairs against each other is such that their external structure is seen with difficulty. That the hair is imbricated any person may be convinced by rubbing a single one between the fingers, first in one direction and then in the other; when the resistance offered in drawing it backwards (that is, from the points to the root) may be readily felt. This affords a curious example of the delicacy of tactile feeling over sight. “From a consideration of this circumstance, and finding the hairs of infants frequently matted or felted together in small knots, after washing, arising from their jagged surfaces,” Mr. Pritchard “was induced to examine the latter, and finding the asperities much more decided than in that from the adult, procured a specimen from a babe only two hours old, in which the imbricated structure was very distinct.” In specimens of this hair mounted in Canada balsam the exterior characters are obliterated.

*Hair of Caterpillars.*—The hairs of some species when

examined by the microscope resemble branches of the black thorn ; others possess compound branches on each side like a fan, resembling the feathers of the peacock's tail.

*Hair, transverse sections of:—Human Hair.*—The structure of the hair is a subject of some interest ; and many observers with the microscope have been unable to satisfy themselves, when it is viewed in the ordinary way, as to whether it was a solid cylinder or a tube. By examining under the microscope a thin transverse section of hair, the determination of its tubular structure is at once decided.

It may not be amiss to mention here the manner in which such sections can be procured, as, to many persons, the difficulty of this is insurmountable. Leeuwenhoek adopted the following plan. Having shaved himself very clean, he repeated the process a few hours afterwards, and then washed and mounted on a slider the portion of beard thus obtained. This method, besides affording many other objections, does not permit of our examining any other kind of hair than that of the beard, and therefore has induced us to contrive the following:—Take a lock or bundle of any hair of which it is desirable to make sections, and dip it into strong glue ; by this means the hairs will adhere together, and form when dried a hard solid rod. This rod is then to be cut with a razor or suitable knife in the same manner as thin sections of wood are cut.—Power 120 diameters.

*Hair of Elephant, transverse section.*—This hair is solid,

but not of uniform texture; hence its examination under the microscope possesses interest.—Mean diameter  $\frac{1}{30}$ th of an inch.—Magnifying power 175 diameters.

*Heads, Insects.*—The manducatory apparatus of insects is a subject of great interest to the entomologist. The two grand divisions of insects into Mandibulata and Haustellata are founded thereon; the former division having jaws, the latter a proboscis or sucking-instrument. As microscopic subjects, when admissible, it is well to have them preserved *in situ*, as also dissected. The heads of beetles, butterflies, and moths, form excellent opaque objects, and instruct us as to the arrangement and disposition of the eyes, mouth, palpi, antennæ, &c.

*Horse Hoof, section of*—resembles in structure that of whalebone. By polarised light, and a thin plate of selenite being placed under the object, it is very beautiful.—Magnifying power 100 diameters.

*Infusoria.*—In the Catalogue only those genera are given which can be preserved dead. By far the greater number are loricated—that is, covered with a shell; this shell in some genera is composed of silica; in others carbonate of lime forms the basis. These shells may be mounted in Canada balsam. The softbodied animalcules, when mounted, by drying on a slip of glass serve principally to illustrate their muscular system, or when previously fed on coloured substances, as indigo, carmine, sap green, &c., to show the form of their digestive organs. In general, however, when dried, they lose much of their external characters, and possess, except

for verification of some special organ or system, little interest to the general observer. The forms, flutings and sculpture of the loricated Infusoria are on the contrary always of deep interest. The chief localities from which the fossil shells of Infusoria have been obtained are given in the Catalogue. In these deposits it is usual to meet with specimens of several genera together. The relative numbers of each genus found in a deposit afford much information as to its period; while the state of their preservation unfolds to us the conditions of disturbance under which the strata were formed.

It would be out of place here to enter into a detailed account of these numerous and interesting creatures, especially as the public are in possession of more than one illustrated work on the subject of Infusoria. The first work wholly devoted to the Natural History of Animalcules was that by Mr. Andrew Pritchard, which appeared in 1834. In 1838 Dr. Ehrenberg published his large work on this subject, entitled 'Die Infusions-thierchen,' price 18 pounds. In 1841 appeared the first edition of Mr. Pritchard's larger work entitled 'History of Infusoria, Living and Fossil,' with coloured plates, price 30 shillings, or with uncoloured plates price 12 shillings. For those who do not wish to enter into the minutiae of this subject a separate publication of the First Part, or 'General History of Animalcules,' together with all the engravings, may be purchased for five shillings. To these works and Dr. Mantell's 'Thoughts on Animalcules,' the reader is referred.

Among the most remarkable and it may be added beautiful fossil shells of Infusoria are those recently discovered in guano, especially that obtained from Ichaboe. These remains, when separated from the animal and earthy matters in which they are found, and mounted in Canada balsam, exhibit all the delicate and symmetrical structure of the recent species, with the addition of brilliant tints. The latter peculiarity is not met with in the shells of any other deposit. The genera of fossil Bacillaria (most beautiful as regards colour) are the *Actinocyclus*, *Gallionella* and *Tripodiscus*.

*Larvæ of Insects.*—The young of insects when they emerge from the egg are called *larvæ*. They differ greatly in form and habits from the parent. In this the caterpillar state they attain their full size, when they become partially or wholly torpid; they are now called *pupæ*, or *chrysalides*. During this period their internal structure undergoes a marked change to prepare them for the perfect state either of flies, butterflies, or beetles, &c. In this latter condition alone are they able to propagate. Their metamorphoses are certainly the most instructive part of Entomology, although greatly neglected until of late years. The remarkable change in the habits of a creature from an aquatic mode of existence to that of an aerial one, must be accompanied with as great a change of structure adapting it to such different elements; yet in the cabinet of the entomologist few if any specimens will be found except those of the imago state. The aquatic larvæ were brought prominently

before the public by the authors of the 'Microscopic Illustrations' and 'Cabinet.' Those works contain numerous drawings of them; and the circumstance of their subsequently forming the staple material of the microscopic exhibitions, proves the interest taken in them by the public. In the Catalogue, a few only have been given, from the difficulty the author has found in correctly naming the species or even the genera to which they belong. The perfection and permanency in which larvæ may be preserved in Canada balsam, render it more than probable that at no very distant period no entomological cabinet will be considered complete that does not contain specimens of insects in the larva and pupa as well as in the perfect state, to which may be added their eggs. Then, and not till then, shall we be able philosophically to understand the economy of these numerous and diversified beings, and the important purposes they subserve in the animal kingdom.

The recent discoveries of the Danish naturalist Steenstrup, described in his work on the *Alternations of Generations*, by which many of the lower classes of invertebrate animals are developed, differ essentially from the metamorphosis of insects. In insects neither the larva nor the pupa has the organs necessary for increasing or propagating its species. In fact, metamorphoses or transformations only imply changes which occur in the *same* individual. In those creatures which are developed by "alternating generations" we see "the remarkable and till now inexplicable natural phenomenon of an ani-



mal producing an offspring, which at no time resembles its parent, but which, on the other hand, *itself* brings forth a progeny, which returns in its form and nature to the parent animal, so that the maternal animal does not meet with its resemblance in its own brood, but in its descendants of the second, third or fourth degree or generation; and this always takes place in the different animals which exhibit the phenomenon, in a *determinate* generation or with the intervention of a *determinate* number of generations." As examples of this mode of development, Steenstrup adduces the Medusæ; certain Zoophytes, as the genera Coryne, Campanularia, &c.; the cyclical development of the Vorticellæ among Infusoria, and of the Aphides among Insects.

*Leg of Bee with nectar.*—If a Bee be caught immediately after it has been gathering the nectar from some flowers, and the inner side of the legs be examined, they will be found laden with the material on which the insects feed, and from which they elaborate the wax and honey. The leg is best examined when mounted on a half-inch black disc, with a power of 30 diameters. (*Note.*—This object should not be put away with others, as the vegetable matter is liable to mildew or to invite small acari to feed upon it.)

*Muscular Fibre.*—The important functions of the muscles in the animal economy—whether we consider their powerful and incessant action in the heart, their strength in the legs, or the wonderful and varied effects produced by their energy in the hand—render their *modus operandi*

a subject of deep interest to the reflective mind. What subject can be more interesting than the study of the means by which the pianist executes a rapid piece of music? or the precision with which the anatomist dissects the most delicate tissue, and the artist portrays every expression of the human face? The action of a muscle is well understood; the motions it produces being occasioned by its contraction, and the muscle swelling at the same time that it shortens; but in what manner the individual fibres act, remained for the Microscopist to ascertain. The theory at present in fashion is, that the ultimate form of all organic bodies is a cellule. This form, however, in the present case involves some difficulties. In 1840 Mr. Pritchard was led to consider this subject; and it occurred to him that the best method of discovering the true form of the ultimate fibre of muscle, would be to select a fibre from the most highly developed muscle. This he accordingly did, and prepared several slides of fibre. From a careful microscopic examination of these, he was satisfied that the fibre was spiral and inclosed in a membranous sheath. Some time afterwards one of these preparations fell into the hands of Dr. Leeson of St. Thomas's Hospital, who also felt persuaded of their spiral nature; but after making himself preparations from several muscles, which would not support this view, he considered some error might have arisen in the naming of the slide he had from Mr. Pritchard. Dr. Leeson determined to follow up the investigation, applied to Mr. P. for the name of the muscle, and was informed accord-

ingly, Mr. P. also assigning the reasons that induced him to make choice of it. Dr. L. with great skill and perseverance subsequently made several preparations, in which he most beautifully dissected out the spiral fibre with its inclosing sheath. This object requires a magnifying power of from 300 to 500 diameters, with great defining power, considerable penetration, and a pure illumination.

*Oysters, young.*—During the spawning season, if an oyster be cut open, a thick opaque fluid may sometimes be noticed. If a little of this is taken up on the point of a scalpel or penknife, and rubbed on a hard substance, and it has a gritty feel, it is almost certain to be the ova. To examine these under the microscope, place a drop of this thick fluid on a slip of glass, and cover it with another thin one; and it is then ready for observation. These ova are of the same form as the parent, but more convex. The shell is perfect, and the muscle which holds the two valves together may be distinctly seen through the transparent shell. They are often not more than the  $\frac{1}{200}$ th of an inch in diameter. They may be mounted as permanent objects.—Magnifying power 200 diameters.

*Pearl, Nacre, or Mother-of-Pearl.*—To exhibit the true formations of this structure it should be cut in two directions; that is to say, two specimens must be procured, the one a thin section cut parallel to the shell, and the other vertical to it. The former exhibits the mode of the cropping out of the layers; the edges and folds produce the beautiful colours by which this substance is

distinguished, the reflected ray from one groove interfering with that from the adjoining one. The vertical section shows the thickness and superposition of the several layers. To exhibit the lines which occasion the colour, a power of 170 diameters is necessary. The layers may be seen with a power of 60. In consequence of the reflection from the edges of the layer, *nacre* is more translucent in one direction than in another.

*Pearl*.—This form of secretion of nacre, which is so much prized for ornamental purposes, is considered as resulting from a disease, or rather that small fragments of a foreign hard substance having obtruded themselves within the shells of the mollusk, the creature covers them with layers of the nacre (commonly called mother-of-pearl) that lines the interior of the shell. If a pearl be cut into very thin sections, the concentric layers are readily distinguished under the microscope (power 100 diameters). The central mass varies in almost every pearl.

*Proboscis of a Bee*.—Few objects when mounted in balsam yield to this in variety of form and richness of colour. Swammerdam has given a folio drawing of this object in his work entitled 'The Book of Nature.' To furnish a full description of this organ would occupy many pages; the reader is therefore referred to the object itself. A perfect specimen well prepared is of much value; but good ones mounted in balsam may be had for eighteenpence.—Magnifying power, for general view 30 diameters; for details, 175 diameters.

*Jaws of Mollusca*.—The manducatory apparatus of

these animals are interesting microscopic objects. "In the marine tribes there is a pair of these instruments acting horizontally; but they differ so much in size, form, and even consistence, in the different genera, that no general description could be made applicable."—*Mag. Nat. Hist.* vol. viii. p. 74.

*The Respiratory System of Insects.*—There are few subjects which offer more interesting materials for microscopic examination than the beautiful and varied organism by which the vital functions are performed in insects. In the larva or early stage of their being, this apparatus has several modifications, according as the creature is an inhabitant of the earth or the water.

These creatures do not breathe by lungs, nor do they inhale the air by the mouth. In the terrestrial kinds the example best suited for examination is the larva or caterpillar of the Willow Moth (*Cossus ligniperda*), on account of its large size. This larva often attains the length of nearly three inches, as shown in fig. 2 (p. 54). Below the head are seen the six feet, and towards the middle commence the pairs of false feet. Along each side of the body is a row of oval apertures called spiraculæ; by means of these the air is admitted and passes along the tubes on each side. The arrangement of these tubes, called tracheæ, with their numerous branches, is shown in fig. 1.

In the construction of the tracheæ, the chief aim is to obtain a delicate, light and flexible tube which shall not collapse. This is effected by means of a strong spiral fibre wound inside the membrane composing the tube, as

seen in fig. 3 (p. 55), which is a magnified drawing of a portion taken from the part *b*. This exquisite microscopic structure is the same even in its most minute ramifications.

In the formation of the spiraculæ it is desirable to render the entrance of air as free as possible, but to prevent

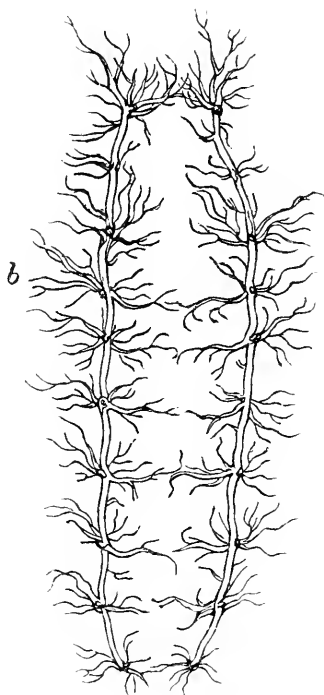

*Fig. 1.*

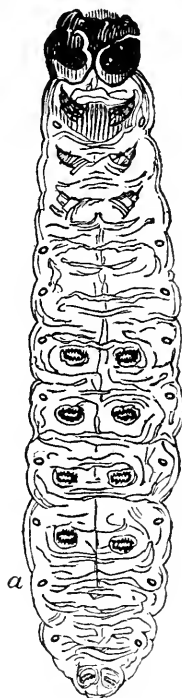
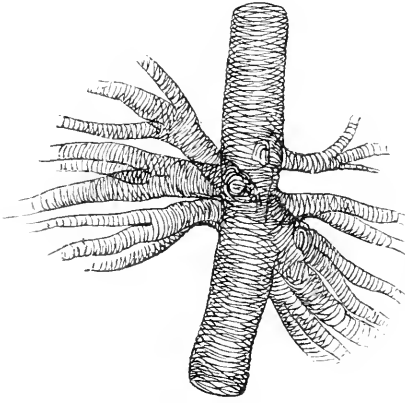

*Fig. 2.*

the admission of any particles of foreign matter; and these objects are effected by the mechanism represented in fig. 4, which is a highly magnified view of the small oval apertures seen along each side of fig. 2.

In aquatic creatures the above arrangement of the

respiratory system would be objectionable, inasmuch as the animal would be constantly required to leave the water to breathe. The beautiful arrangement shown in



*Fig. 3.*

fig. 7 is therefore adopted. This system belongs to the larva of a *Dytiscus* seen at fig. 5 of the natural size.

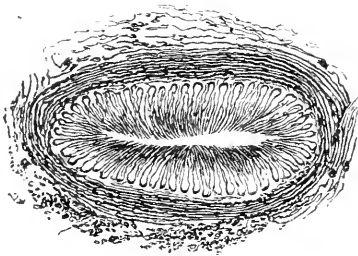

*Fig. 4.*

For the admission of air there are only two openings, both situated near the tail, which it brings to the surface of the water whenever it is necessary to take a fresh supply. Fig. 6 is a magnified portion of the trachea, to

exhibit the spiral nature of its structure. Mr. Pritchard, from whose preparations these engravings were made, remarks in the 'Microscopic Illustrations' that this

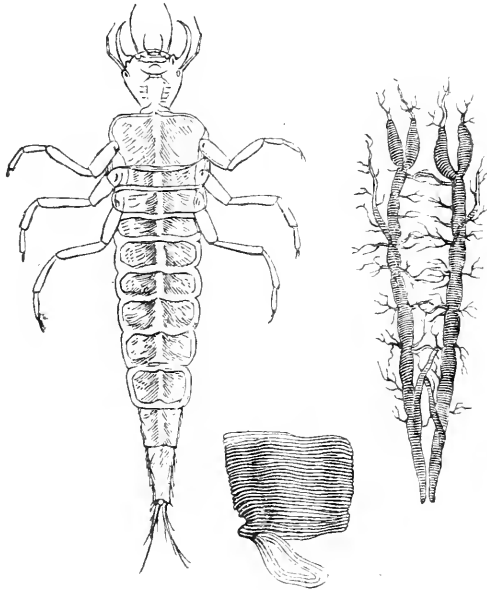

Fig. 5.

Fig. 6.

Fig. 7.

structure admirably illustrates the interference of light. For this purpose the slide containing the tracheæ should be held close before the eye, when looking through it at a lighted candle about a yard distant; the coloured images will then be seen on each side of the real one. From the distance at which these images are apart may be deduced the diameter and the distance of the spiral fibres from each other.

In the perfect beetle of this larva, the spiraculæ are arranged along each side of the back under the wings,

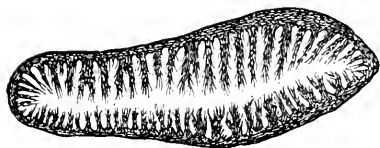
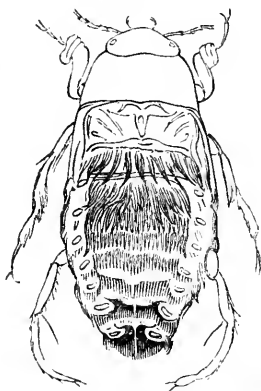

as shown in fig. 8, which represents the *Dytiscus* without the elytra and wings. The largest spiraculæ are nearest the posterior extremity of the body. Fig. 9 is a magnified view of one of these valves or openings, and fig. 10 a portion of the same highly magnified, to show the mechanism by which foreign substances are prevented from entering.

*Fig. 8.**Fig. 9.**Fig. 10.*

*Scales of Fish.*—The study of the dermal covering of fishes has of late years become of vast importance, arising from the investigation and discovery of M. Agassiz, who has demonstrated that the nature and form of the

scale are a constant indication of the nature and characters of the fish to which it belongs. The application of this knowledge to the fossil remains of these animals has already produced abundant fruit, while the more recent discovery of fish-scales in flint, bids fair to extend our acquaintance with the finny tribes which were coeval with the different strata of the earth's crust.

Professor Agassiz has formed the class of fishes into four orders, according to the structure of their covering, as follows: ENAMELLED SCALES.—1. *Placoidians*, Fish characterized by having their skin irregularly covered with plates of enamel; in some genera these are large, in others they are small, almost points:—Examples, shagreen on the skin of some sharks, and the prickly toothlike tubercles on the skin of rays. This order includes all the cartilaginous fishes of Cuvier, except the sturgeon.—2. *Ganoïdians*. The fishes of this order have angular scales composed of horny or bony plates covered with enamel; fifty out of sixty genera are extinct:—Examples, sturgeons and bony pike.—SCALES NOT ENAMELLED.—3. *Ctenoïdians*. This order of fishes have the scales serrated, or notched, on their posterior free edges:—Example, the perch.—4. *Cycloïd* fishes have smooth scales, simple at their margin, composed of layers, which give the outer surface an ornamental appearance:—Example, the herring, salmon, &c.

The scales of fish are formed from a secretion similar to that from which the epidermis or scarf-skin of animals is secreted. This secretion takes place periodically in the

fish of the last order; hence a fish-scale is formed of layers, and as each succeeding layer is larger than the previous one, when a cycloid scale is viewed through the microscope it exhibits a series of striæ of the form of the scale. This form of the scale varies in different genera of fish; hence they afford good specific characters. Along each side of a fish a straight line or a curved line may often be observed: this is called the *lateral line*, and is produced by a row of scales furnished with a duct, or tube, from which exudes an oil-like fluid for lubricating the surface of the fish. Among the various kinds of fish-scales selected for microscopic objects, those of the eel are much prized, as it was formerly considered that that fish had no scales.

Some scales when viewed by polarised light have a brilliant effect. They may be mounted in Canada balsam. A magnifying power of 30 diameters is generally sufficient for this class of objects.

Fossil scales of fish are often abundant in flint-stones. Those from the gravel-drifts at Gillingham in Surrey, and the flint-nodules in the chalk between Gravesend and Rochester, contain them. To obtain and prepare these specimens for the microscope, select some large nodules of flints and break them up into thin pieces. After each fracture, examine the surfaces with a hand magnifier. It is barely possible to reduce a dozen flints from the above localities without finding some specimens of fish-scales. They are best examined as opaque objects under a very low power. .

The scales of the eel when mounted in Canada balsam are almost obliterated under common light, but with polarised light are brilliant objects.

*Scales of Insects.*—Butterflies, moths, and many other insects, are covered with scales or feathers, overlapping each other like the tiles on the roof of a house. They vary greatly in form and size, and from the difficulty with which the structure of many of them is developed by the microscope they become excellent tests of its penetrating power. (See *Test Objects*). In the Catalogue are introduced the names of those insects which possess the most interesting and peculiar scales. Those taken from the red parts of the wing are not so various as the scales from the white and blue colours.

*Scales of Euplœa limniacea* (?).—Some observers unacquainted with the lined test-objects experience a difficulty in bringing out the *cross striæ* on the scales of the *Morpho Menelaus* and others more delicate. It may be useful to mention, therefore, for this purpose, the scales from the wing of the *Euplœa limniacea*, and the blue ones from the *Papilio Paris*, as the cross striæ on these are easily developed under a power of 100 diameters and oblique illumination.

*Shell.*—The organic structure of shell has long been a subject of discussion among scientific men. Some have considered it as produced in alternate layers of animal and earthy matter, the one secreted in the day and the other at night. Again, others consider the shell of a cellular nature, in which after its formation earthy matter

is deposited. Some naturalists have considered shell analogous to the bone of animals, and like it receiving nourishment from the animal; while others liken it to the horny structures of animals, as the hoof, nails and hair, which when fully developed cease to hold any vital communication with the animal.

Shell has been classified variously by different observers. Mr. Hatchett separated it into two groups, which he called *Porcellanous* and *Nacreous*, the carbonate of lime in the former being accompanied with very little animal matter, while in the latter the animal matter is so abundant that after the earthy matter is dissolved by dilute hydrochloric acid there remains a perfectly definite membranous animal residuum. Another division of shells has been founded on the manner in which the carbonate of lime has been deposited by the animal, some shells having a *crystalline* fracture, others a *granular* or *concretionary* fracture. According to the experiments of Dr. Carpenter, undertaken at the request and expense of the British Association, the calcareous matter in *all* shells is nearly *equally crystalline* in its aggregation, and the particular *forms* which their fracture presents are determined chiefly, though not entirely, by the arrangement of the *animal basis* of the shell, which possesses a more or less highly organized structure.

All thin sections of recent shell are *translucent*, except when the colouring-matter is opaque, or when the calcareous matter is deposited in a chalky state between the true laminae of the shell, as in the oyster. All thin sec-

tions depolarise light, so that the shell appears bright upon a dark ground in the polarising microscope; hence it follows that the calcareous matter of the shell is in a state of crystalline aggregation.

Dr. Carpenter classifies shells into—1. Prismatic cellular structure, as exemplified in the *Pinnæ*;—2. Membranous shell substance—examples, *Mya*, *Anatina* and *Thracia*;—3. Nacreous or pearl structure—example, the inner substance of certain species of the *Ostrea* and *Mytilus*;—4. Tubular structure—example, outer layer of *Anomia Ephippium*, *Lima scabra*, and in *Chama florida*; in some cases the tubes run at a distance from each other obliquely through the shell, as in *Arca Noæ*;—5. *Cancellated structure*. Examples of this latter division which somewhat resemble the cancelli of bone, are only met with in certain fossil shells belonging to the *Rudistes*—example, *Pleurorhynchus Hibernicus*.

Shell should be examined microscopically in three ways—by reflected light, by ordinary transmitted rays, and by transmitted polarised light. For the first, fragments of shell will suffice; for the second, thin sections cut both vertically and transversely are necessary. To exhibit the animal basis of shell, specimens must be procured in which the earthy matter has been removed by immersion in dilute hydrochloric acid.—Magnifying powers from 10 to 250 diameters.

*Shell of the Crab*.—If a portion of the shell of a crab, about half an inch in diameter, be ground very thin, so as to leave only the outer layer of colouring-cells, and

then mounted in Canada balsam between plates of glass, it will prove an admirable object for the gas-microscope. In this example the cells containing the colouring-matter are large, and therefore suited for low powers.

*Sole-skin*.—This is an interesting opaque object. It should be cut or punched into pieces about half an inch in diameter, which should be attached to a black disc or on a wood slide. The mode of attachment of the scales to the skin and the serrated form of the former deserve notice.—Magnifying power 30 to 60 diameters.

*Spiders*.—This order of annulose animals has been little attended to by microscopists, owing to the difficulty of preserving the specimens entire. The most remarkable point is the grouping of the eyes, which, unlike those of insects, are single. In one genus (*Nops*), the species have only two eyes; but spiders are mostly provided with six or eight. In some large foreign specimens the hairs are curiously marked. The respiratory apertures are usually four, placed near the spinnerets, towards the base of the abdomen.

*Spiders' Web (Clubiona atrox)*.—The web of this spider which Mr. R. Potter considers a very difficult test object, has in recent specimens “the complete structure of a regularly-woven net” upon it. It requires a magnifying power of 400 to 500 diameters to penetrate its structure. “The *Clubiona atrox* is found in the crevices of old walls, and may be known by its making an irregular fleecy-looking web, a thread of which when examined under the microscope” (by stretching a short length across a bent

wire) “consists of a straight and strong line, upon which is attached a white and curved line, and the whole is surrounded by a broad blueish band. There can be no doubt that this blue band consists of lines produced by the spider, and woven into the delicate tissue.” See Brewster’s Journal, new series, vol. vi., p. 64.

*Spines.*—Thin transverse sections of the spines of some Mammalia, as the porcupine, hedgehog, &c., are very beautiful transparent objects for the microscope. The hedgehog spine requires a power of 100 to 150 diameters, while the quill of the porcupine requires only 30 to 60 diameters. The spines of certain Echini, when cut into very thin sections so as to leave only one layer of cells, are often exquisitely rich in colour. Dr. Carpenter exhibited some specimens of this kind, very admirably cut, at the Southampton Meeting of the British Association in 1846.

*Teeth.*—The formation of the teeth has of late years been minutely investigated on the Continent by Professors Purkinje and Retzius, and in this country by Professor Owen and others. The preparation of thin sections of teeth being now brought to great perfection, has facilitated the researches of the naturalist, and has thus enabled him, with the aid of the achromatic microscope, to ascertain all the minutiae relating to their structure.

A tooth consists of three distinct structures, the relative proportions and arrangement of which constitute the chief differences in the teeth of various animals.

1. Enamel.—This is crystallized phosphate of lime



deposited in the form of long prisms, each about  $\frac{1}{3000}$ th of an inch in diameter, produced in animal cells, the latter being almost obliterated when the tooth is fully formed. In human teeth a coating of enamel is formed over the crown of each. In the teeth of some animals the enamel is disposed in vertical layers among the other structures of the tooth; this is especially the case with the grinding-teeth of large herbaceous animals. The hardness of the enamel is such that it will in some cases produce sparks of fire like flint when struck together. This fact is not a little remarkable considering the chemical composition of the enamel, and is one among many examples of the vast changes produced by the living principle upon matter.—Enamel depolarises light.

2. Dentine, or Ivory—forms the principal body of which teeth are composed; indeed in some instances, as the tusk of the elephant, no enamel is present. The amount of animal gelatine in ivory is often very considerable. The earthy matter is usually deposited in the form of fine branching cylindrical tubules radiating from the centre of the tooth; on the ends of these dentine tubules the ends of the enamel prisms are placed in the human teeth. Ivory is now established by Professor Owen as an ossification of the pulp of the tooth.

3. The Bone, or Cementum, of Teeth—is composed in man of a mass of earthy matter and cartilage, having minute cavities or bone-corpuscles and calcigerous canals. In the molar teeth of the cat-fish, the cavities are large and the canals are wanting.



In some specimens prepared by Mr. Pritchard, a thin vertical section has been made of a tooth *in situ*, thus exhibiting a section of the jaw with its cavities for the nerves and vessels, as also the manner in which the alveolar process which forms the socket is constructed. This process, when a tooth is extracted, is absorbed. Each slide should (when the size of the specimen will permit) contain both a transverse and a vertical section of a similar tooth; otherwise we cannot obtain a correct idea of their true structure. In very large teeth, as the grinders of the elephant, one quarter of a transverse section is sufficient for microscopic examination. It has been long a question among physiologists, whether a tooth in man when once perfected, grows or is renewed. Some recent experiments warrant the assertion, that even a fractured or decayed tooth may be restored.

The magnifying powers best suited for a general examination of teeth is 40 diameters. For viewing the canals 100 to 150 diameters will be required. Under the polarising microscope many teeth are highly interesting objects, especially large teeth, as those of the sea-horse, transverse sections of which sometimes exhibit the black cross.

*Whalebone*.—This substance, which grows in the form of long plates from the interior of the upper jaw of the whale instead of teeth, serves to intercept the small prey on which that mammal feeds. To examine its structure under the microscope, it is necessary to obtain a very thin slice cut across the fibres, and to mount it between

plates of glass, under a power of 50 or 60 diameters. The varied pores and beautiful concentric circles around them may be readily seen.

*Wings of Butterflies, &c.*—"In the selection of the wings of insects given in the list, I have introduced many which require to be mounted in Canada balsam, in order to render them sufficiently diaphanous to be examined as transparent objects. The larger wings, when entire, are especially suited to the oxyhydrogen or solar microscope. Here instruction and amusement might go hand in hand: a wing from each order of insects might be placed in one slide in such a position that by using a low power the whole of them might be exhibited on the screen at one view, and by their characteristic differences being thus brought into apposition their distinction might be permanently stamped upon the mind."—*Pritchard's List*, p. 11.

The transparent wing of the Hemerobius is admirably adapted for exhibiting, in the living state, the circulation in its nervures. The tubular structure of the nervures is often distinctly seen in wings mounted in Canada balsam, those parts of them which are injected being transparent, while the parts filled with air appear dark at the sides.

The ocellus or eye-like spot from the wing of the Emperor Moth is interesting as showing the concentric arrangement of the scales upon the membrane of the wing. (Power 30 diameters.) The form of the scales and their markings, which may be seen *in situ* when that

portion of the wing is mounted in Canada balsam, require a power of 100 diameters.

The wing of the *Asilus crabroniformis* when mounted in balsam is a beautiful example to illustrate the hollow structure of the pterocosta, or wing-bones.

The wings of the Phryganea are often covered with stout hairs or bristles; the base of these, as also the pores or openings placed at intervals on the pterocosta, are worthy minute examination.—Power 150 diameters.

*Zoophytes*.—Animal-plants usually inhabit the bottom of the sea, where many of them perform an important office in producing solid masses of limestone, as exemplified in the formation of coralline islands. Naturalists of the Continent include in this class of animals not only the Corallines and Sponges, but also many of the small Mollusca, Entozoa, Star-fish, and even Infusory Animalcules.

For a long period the zoologist did not consider zoophytes as animals, but left the study of them to the botanist; and even now, many observers are disposed to class them with plants, while others hold them as a link between the two kingdoms. The animals are generally found in clusters or compound, sometimes communicating at a common centre, at other times distinct and only connected by the solid matter of which their polypidoms are formed. Some few, as the common freshwater polype, do not secrete any hard substance either around or within them. Those which are described and figured in the 'Notes on Natural History' are excellent microscopic objects, and if kept in cylindrical glass vessels of water are always ready,

without any trouble in preparation, to be examined by the "Standard Microscope" hereinafter described. It may be remarked here, that for examining this class of animals with facility, the mechanical part of the microscope should, as in that instrument, be so constructed as to revolve about its stem; by such contrivance vessels of any length can be employed without removing the zoophytes from them, and thus a series of observations can be made with ease. When the creatures are marine zoophytes and require a fresh supply of sea water occasionally, the glass vessels with their contents can be kept in a pail of sea water, and thus a fresh supply is given without disturbance. In this manner the functions of these vegetative animals, and the manner in which they seize and devour their prey, can be readily observed.

The polypidoms or cells formed by these creatures are excellent opaque objects under low powers, especially the genera *Flustra*, *Sertularia*, and some others mentioned in the Catalogue. The living masses of *Cristatella*, often found in clear running ditches, are interesting microscopic objects.—The magnifying power required for this class of animals varies from 25 to 100 diameters.

VEGETABLE.—The vegetable kingdom furnishes the microscopist with a large amount of employment. His researches are not confined to objects of high culture, but the wild and diminutive often present a larger amount both of instruction and amusement than the most choice and highly cultivated. For this reason the author has been obliged to exclude from the Catalogue some sub-

jects of great interest, such as the seeds and seed-vessels of numerous minute wild plants, the names of which are unknown. In his own cabinet, these objects are distinguished on the labels as "Seed No. 1," "Seed No. 2," and so on; but this numeric arrangement, it is clear, is not admissible in print.

The elementary organs of plants require the assistance of the microscope to render them apparent; and a good work on Microscopic Botany would be highly valuable at the present day. The system of classification adopted by most modern botanists is presumed to be founded on natural arrangement and organic structure: hence it is important in this study to be acquainted with the management of the microscope, as well as with the actual form of the bodies under examination. Without a thorough acquaintance with the varied appearances of known objects presented under the microscope, very little reliance can be placed on an observer's investigations with that instrument; indeed, on this account, until recently, microscopic discoveries were rarely to be depended upon. Those who wish really to understand what they are viewing in a microscope will do well repeatedly to read the 'Memoir concerning the Verification of Microscopic Phenomena' in the supplement to the *Microscopic Illustrations*. In no case has the want of this knowledge been more seriously felt than in respect to the errors it has occasioned as to the form of the elementary tissues of plants. In the works of the best botanists are sometimes introduced erroneous hypotheses regarding the functions of

plants, owing to imperfect notions of the form of the organs themselves.

*Cellular Tissue*—is the first and most generally developed simple form of vegetable life. No plant, whether belonging to the highest or the lowest tribe, is without it; many are destitute of any other kind of tissue, as the Lichens, and some fresh water Algæ. It consists of distinct closed vesicles or cellules of various forms and varied contents; they cohere together, and the consequent pressure in some respects modifies their form. They differ greatly in dimensions; the largest are found in aquatic plants, of which the *Nitella* is a good example, the stem being composed of a single cell, sometimes four inches long. The general diameter of ordinary cellules varies from  $\frac{1}{20}$ th to  $\frac{1}{50}$ th of an inch. The plants named in the Catalogue under this heading (*Cellular Tissue*) furnish most of the varieties of this kind of tissue.

*Elder Pith, &c.*—The pith of exogenous trees and plants is situated in the centre of the stem, and consists of cellular tissue. In the elder and fig it is large in proportion to the diameter of the stem; in the oak and elm small. In the willow it is compact; in the walnut loose and interrupted. In young trees the cellular tissue is also to be found in the root. The form and diameter of the cells vary in different specimens. The membrane of which they are composed is always colourless and destitute of perforations. The petals of flowers are mostly composed of cellular tissue; their brilliant colours arise from the fluid contained within the cellules.

*Cotton.*—The fibres of cotton are readily distinguished under the microscope from those of linen, wool, &c. Cotton fibres are tubular, and are formed of pure cellular tissue. They grow in the fruit-pod surrounding the seeds. These tubes, from the thinness of their sides, often collapse; hence they appear like flat ribbons or bands; but the fact that they are hollow may be proved by immersing them in a drop of Canada balsam and heating it over the flame of a candle, placing the slide on the stage of the microscope while warm, when portions of the fibre containing air will be seen dark, while those filled with balsam are clear and transparent; as the slide cools the air in the tubular fibres contracts, and the balsam is seen in the act of filling them. The reason assigned for the preference given to linen (flax) over cotton for lint, for surgical purposes, is that the fibres of the former are solid cylinders, and those of the latter flattened bands, the edges of which are supposed to irritate the wounds. Cotton, which is almost entirely carbon, does not affect polarized light. The newly discovered explosive gun-cotton transmits a line of light when polarized. The commercial value of cotton fibres, usually called cotton wool, depends upon the length of the staple or fibre, and their colour. The finer kinds of muslin are made from the unripe pod fibre.

*Membrane without fibre.*—If the seeds mentioned under this heading be immersed for a short time in water, they become covered with a white flocculent matter, which on examining it under the microscope will be found to be



curious spiral membrane. Many persons have supposed this phenomenon to be the development or growth of the seed. This is readily shown to be a fallacy by the following interesting experiment:—Cut off with a penknife a thin slice of the testa, or covering of the seed; place it on a slip of glass under the microscope armed with a power of about 50 diameters; bring the object in focus, and while in its place drop upon it from a small glass tube a little water, then cover it with a plate of thin glass. Attentively observe your object, and in a few seconds the membranous tubes will be seen to unroll themselves at the edges.—They may be preserved by dropping a little gum-water upon them, and drying in that state.

In vol. xix. of the Linnæan Transactions Mr. Kippis informs us, that on the seeds of an *Acanthodium* from Upper Egypt may be seen close-set seeming hairs; but which, when immersed in water, swell out, and become broader, and then evidently consist of tufts of from 5 to 20 long, cylindrical transparent tubes, which adhere to one another for one-third of their length, and contain one, two, and sometimes three spiral fibres, which are strongly adherent to the membrane of the tubes. The fibres are sometimes interrupted by rings. In the lower part, where the tubes adhere together, the fibres are reticulated; towards the end the spirals lie asunder, and in the middle they are bound together by delicate filaments given off from the principal fibres.

*Vascular Tissue*—presents the most varied and interesting subjects for microscopic examination. Spiral vessels

consist of membranous tubes with conical extremities, internally furnished with one or more spiral fibres. As the vessels grow, the spiral fibre breaks into short pieces, forming rings: the vessels are then called annular: if the pieces of fibres are still shorter, they are called dotted or reticulated vessels. Much discussion has arisen among botanists as to the form of the fibre; that is, whether it be round like a cord, or flat like a ribbon. The root of the hyacinth and the stem (petiole) of the common garden rhubarb, the latter even after it has been cooked, yield spiral vessels in abundance.

*Dotted Vessels.*—A peculiar form of vessel is met with in the common Carrot; it is obtained from the root in a layer between the yellow central portion and the red annulus. As a microscopic object it is very interesting.—Power 150 diameters.

*Woody Fibre.*—This form of tissue may be readily examined in the examples given in the Catalogue, it being separated from the other elementary organs. The form of the woody fibres of flax (of which our best linens are made) is that of solid cylinders; hence the durability of those fabrics. The diameter of the fibres varies greatly: in some of the Coniferæ it exceeds  $\frac{1}{50}$ th of an inch, while the fibres used in making the threads for the fine French cambric are about  $\frac{1}{300}$ th of an inch.

*Woody Fibre glandular.*—On the sides of the woody fibres of the trees named in this division are small disc-shaped glands: they are disposed in rows, and are best seen in a radial vertical section of the wood. These

glands in recent woods are excellent tests of the *defining* power of a microscope: they are about  $\frac{1}{500}$ th of an inch in diameter. A magnifying power of 100 diameters exhibits them very well.

*Raphides*.—If the leaf or bulb of a common Hyacinth be wounded, a discharge of fluid ensues; if this fluid be received upon a glass slide and submitted to the microscope, a number of minute acicular bodies will be observed floating in the liquid; these are called Raphides. They are common in many Monocotyledonous plants: they depolarize light, and are mostly composed of oxalate of lime.

*Cuticles*.—The external covering of plants, called the Cuticle, consists of a thin membrane adherent to the cellular tissue beneath it. Under the microscope it appears traversed by lines in various directions, giving its surface a reticulated appearance. The form of these reticulations varies very much in different plants: in many they are hexagonal; in others they are prismatic; while in others, again, no determinate geometrical figure can be assigned to them.

If the cuticle of the under side of a leaf of Candytuft (*Iberis umbellata*) be carefully examined under the microscope, among the sinuous reticulations will be observed darker oval spots; these are called Stomata, and are the orifices by which a function analogous to respiration in animals is effected. They also serve for the exit of water from the plant by means of evaporation. Plants destitute of stomata, as the South American Cacti, will

remain in a hot and dry atmosphere without losing their moisture. The form and arrangement of the Stomata vary in different plants. The Catalogue contains a list of the most diversified cuticles, both with and without stomata.—Magnifying power 80 to 150 diameters.

*Flours.*—The meal or flour of grain and other seeds may be distinguished from each other by the microscope. To facilitate these researches, specimens of known qualities should be mounted and labelled, so as to be ready for comparison with any specimen to be examined.

*Hairs, Down, Pili, Ciliae, &c. of Plants.*—These appendages usually grow upon the leaf, but are not confined to any particular part. In the plants which produce cotton (*Gossypium herbaceum, &c.*), the hairs are attached to and envelope the seeds. Hairs are composed of cellular tissue. Their functions are said to be either lymphatic or secreting. They offer great varieties in form; hence they are much admired as microscopic objects. The stellated hairs upon the leaf of the *Deutzia scabra*, when viewed *in situ* by reflected light under a power of 30 to 60 diameters, are highly interesting. When separated by a lancet from the leaf, and mounted as transparent objects, they resemble minute star-fishes (*Asteriæ*). The hairs of the Stock Gilliflower (*Matthiola incana*) are forked and lie parallel to the leaf, supported in the middle by short footstalks. These are said to be divaricated. The cellule which forms the footstalk is supposed to be an elevated part of the cuticle.

Hairs are sometimes branched, as on the petioles of

the Gooseberry. In the common Borage and the *Anchusa angustifolia*, the base has a bulb, like the spines of an Echinus. Examples of the principal varieties of hairs will be found in the plants named in the list.

*Volatile Oil in Leaves.*—The leaves of the Sage, Black Currant, and many other plants, yield a delicate perfume when touched. This essential oil usually resides in small vesicles on the under side of the leaf; which fact is easily demonstrated, for on rubbing only the upper side no fragrance will be noticed. Of course, for examining the vesicles under the microscope, the under side of a leaf not rubbed must be used.—A magnifying power of 30 to 60 diameters will be sufficient for viewing them by reflected light.

*Pollen.*—The common form of the pollen or farina of flowers is spherical, with either a smooth, punctured or spiny surface; but the most interesting forms are the square, cylindrical, oval with attenuated extremities, and the triangular with convex sides. Examples of these forms, together with several modifications, may be procured from the plants mentioned in the list. The colour of these bodies is usually yellow or red, sometimes blue, never green. In the microscope, pollen is best viewed by reflected light, employing a silver cup or speculum.—Magnifying power 30 to 100 diameters.

The pollen of the Passion-flower is very curious, and if immersed in very diluted sulphuric acid opens and disperses the grains. This observation of course must be made with transmitted light.

The pollen of the *Gesneria bulbosa*, *Datura Stramonium*, *Ipomœa hederacea*, and others, when immersed in a few drops of weak acid placed upon a slider under the microscope, emits a tube of some length. The granular matter in the pollen may then be seen to pass along the tube until the pollen is emptied. Mr. Bauer is of opinion that the matter expelled is not tubular, but simply mucus with a few grains attached. This subject is worthy of investigation, as some botanists not only believe in the tube, but state that by it the fecundating particles of the pollen enter the ovary.

In Orchideous plants the forms of the Pollen-masses are curious and interesting microscopic subjects. The specimens should be preserved on black discs.

The diameter of the pollen varies very much in different plants: among the smallest are those of the Sensitive Plant (*Mimosa sensitiva*).

The magnifying power for viewing pollen as opaque bodies should be from 30 to 60 diameters. For observing the tube and experimenting on them as transparent objects with dilute acid, a power of 200 to 400 diameters is required.

*Algæ*.—This the lowest tribe of the vegetable kingdom is considered by Dr. Lindley as closely allied in organization to the Fungi and Lichens. They are distinguished from both those tribes in being aquatic. The number and variety of the species of Algæ, together with their minuteness, render them appropriate subjects for microscopical study. The green mucous slime-like

matter in damp garden walks, and the hair-like weeds in ditches, are familiar examples of the freshwater Algæ. The sea-weeds which so abundantly cover the rocky shores of our coast are marine Algæ. Of the latter the bays in the South of Devon are rich in specimens, as the labours of Mrs. Griffiths of Torquay testify. For the microscope the smaller kinds of a bright scarlet colour are the most valuable, when mounted between slips of glass in Canada balsam.

The genera *Chara* and *Nitella*, which exhibit the cellular circulation so distinctly, and the disjoined, or *Diatomeæ*, (considered as animalcules by some naturalists,) belong to the freshwater Algæ.

As articles of food the Algæ are almost valueless to man; but their use in manufacture is considerable. Some produce glue; others barilla; while the new elements iodine and bromine are obtained from them.

The sea-weeds often have *Zoophytes* adhering to them: they are then splendid opaque objects, the pearly white dry polypidoms of the *Zoophytes* being seen in strong relief upon the red Algæ.

*Ashes.*—The elementary organs of some plants are composed of silica, lime, &c. These substances may be detected in the ashes of the plant after it has been burnt. The most favourable example for showing the form in which silica occurs in plants, is the husk of the oat or wheat. If a husk of oat be examined under the microscope, (being previously mounted in water or Canada balsam between plates of glass,) a series of bright parallel co-

lumns, serrated on each side, may be observed among the cellular tissue of the husk : if another specimen (dry) be burnt carefully between the glasses, and the ashes be mounted in balsam, the siliceous columns will still be seen. In the ashes of the husk of the wheat, rows of concave discs may be observed, which are composed of some metallic oxide. In the ashes of the calyx and pollen of the mallow may be detected organized lime. In the ashes of coal, a variety of vegetable structures, as cellular tissue, spiral vessels, &c., may be discovered ; and as these vary in the coals from different localities, the place of an unknown specimen may be determined. In these experiments it is necessary to render the ashes transparent by immersion in balsam.

*Active Molecules.*—If a drop or two of clear water be placed upon a glass slide and a little gamboge be rubbed down in it, the particles will be observed in a constant state of activity, even after the slide has been covered by a thin slip of glass and sealed up for years. To observe this motion a very high magnifying power is necessary, say 600 to 1000 diameters. A common single lens will exhibit them very well.

*Bituminous.*—The origin of coal has been a problem with the geologist, the solution of which he has sought for with anxious care. The microscope has at length unravelled its history ; for its vegetable nature is clearly discoverable through all its transitions, from the wood to the peat, lignite, jet, anthracite, and then to the perfect bituminous coal. For successfully conducting these re-



searches the different specimens must be ground into thin laminae, so as to be viewed by transmitted light. In some of Mr. Pritchard's preparations, these sections are made in two directions, the one longitudinal and the other transverse; and by comparing them with similar sections of recent coniferous woods their identity is established. Among the ordinary Newcastle coal may often be selected pieces indicating very clearly the remains of woody fibre, and, more rarely, specimens occur in which the vascular tissue is distinct, spiral vessels covering the surface. Microscopic drawings of various specimens of coal will be found in Mr. Witham's work on Fossil Vegetables.

*Charcoal.*—Thin transverse sections of charred woods offer instructive examples of the formation of the different layers, and for shallow powers or on the screen of the solar microscope are beautiful symmetrical objects.

*Ferns.*—As microscopic objects the most curious and interesting parts of the Fern are their reproductive organs. By the ancients these plants were supposed to be propagated by fairy hands. Swammerdam was the first author who gave a drawing of them. The flowers and seeds, or rather the parts which answer the purpose of these, (for Ferns are considered by botanists both as flowerless and seedless,) are small and hid on the back of the leaves. They should be collected before they are quite ripe. The spores (seeds) are usually inclosed in rich brown capsules, each having an elastic ring about its equator, which when ripe bursts and the spores are

dispersed to a distance. The foreign species named in the Catalogue, from the author's cabinet, offer great variety in their structure, and are among the most interesting for the microscopist as opaque objects.

The development of Ferns may be observed by placing the spores in moistened flannel and keeping it at a warm temperature. At first a single cellule is produced, then a second, and so on. After this the first cellule divides into two, and then the others, by which a lateral increase takes place.

Magnifying power for the Ferns 30 to 80 diameters. For the spores 150 to 300 diameters.

*Fossil Vegetables.*—The perfection to which the art of cutting fossil woods into thin sections not thicker than banknote-paper, and thus rendering them pervious to light, has enabled the botanist to examine by the microscope all the minutiae of their structure. So perfect is their organisation preserved in the fossil state, that in some cases the true form of the glandular discs on woody fibre has been demonstrated when it could not be done in the recent state. Although thin sections of fossil woods are necessarily more costly than those of recent ones, yet no collection of microscopic objects should be without examples. Fossil woods may also be viewed as opaque objects, in which case it is merely necessary to smooth and polish the surface.

Mr. Pritchard, who some years ago introduced the cutting of thin sections of fossils, prepares on each slide, transverse and longitudinal sections of the same speci-

men, similar to his slides of recent woods. By this means a correct idea of the form of the organs can be obtained.—Magnifying power 50 to 150 diameters.

*Fungi*.—This tribe of aërial Cryptogamous plants—of which the Mushroom (*Agaricus campestris*) and the Truffle (*Tuber Cibarium*) are the only wholesome species—contains numerous genera, the study of whose production is important to man from their injurious effects upon his food. The various kinds of mildew upon wheat and vegetable substances are familiar examples of the minute kinds of Fungi, all of which require the aid of the microscope, and in general very high magnifying powers, for their investigation.

*Grasses*.—The stems of many grasses and the husk which envelopes the flowers and seeds, form excellent microscopic objects, especially when silica enters into their composition. The husk of the oat and of the wheat has been mentioned before.

*Lichens*—are an extensive order of Cryptogamous plants, growing upon rocks, bark of trees, old palings, &c., and indicate by their presence dry open situations, while the Fungi are produced in damp places.

*Mosses*.—Our knowledge of the structure of the *Musci* is derived exclusively through the agency of the microscope. They are supposed to be devoid of woody fibre and vascular tissue. When a leaf is carefully examined, the septa which divide the cells are found in some species to take a spiral course. To observe this structure, previously soak the moss in water, to expand the cells. In

collecting mosses, it is essential to preserve them with the theca (seed-vessel); for without it the genera cannot be determined, while this part, and the calyptra and operculum, are the most valuable for the microscope.

*Petals of Flowers.*—The disposition and form of the cellules of some petals, and the colouring-matter within them, form excellent microscopic objects, and when mounted in Canada balsam are permanent. Among the most interesting are the petals of the Pelargoniums and Geraniums.—Power 30 to 100 diameters.

*Petal of the Anagallis.*—The Scarlet Chickweed is a very beautiful microscopic object. The spiral vessels diverging from the base of the petal, and the singular little cellules which fringe the edge, are worthy of notice.—Power 100 diameters.

*Seeds.*—The Catalogue contains many curious varieties in the forms of seeds, also many whose surfaces are elegantly engraved and sculptured. The *Galinsogea parviflora* is surrounded by a ring of radial leaflets, which form a pretty little stellate group.

The seeds of Orchideous plants, especially some species of the Epidendron, resemble silken net purses. The winglets of the seeds of the Sorrel, *Eccremocarpus*, &c., when mounted in Canada balsam and viewed under a shallow power, are beautiful objects.

The septa between the seeds of the Bladder *Ketmia* are worthy of microscopic examination.

Seeds are chiefly interesting as opaque bodies when illuminated with a silver reflector under a power of 30 to 80 diameters.

*Fossil Chara Seeds* are interesting opaque objects. They are globular, and the surface is grooved, with spirals running from one pole to the other. A group of four or five seeds on a black disc, with a power of 30 diameters, affords much instruction.

*Starch.*—The ordinary starch of the laundress, which is an impure substance combined with a blue earthy pigment, is not the material to be here described as a microscopic object. The pure vegetable proximate principle called by chemists starch, of which arrowroot is a common sample, is the subject of the following remarks.

The granules of starch obtained from different plants are found, when examined under the microscope, to differ in size and form. Some are spherical, others elliptical, flask-shaped, polyhedral, &c. Hence this method of examination affords a ready means of detecting fraud in the substitution of one kind of grain for another. The starch granules, although so very minute, are composed of a fine and delicate membrane inclosing a fine mealy powder. It may not be unaptly compared in some particulars to a common pea, in which the legumen is inclosed in a testa or skin. Of course the comparison will not hold as regards the functions of the two. Starch granules are not soluble in cold water, nor is iodine capable of acting upon them while the membrane inclosing its contents remains whole. Indeed it is a most remarkable fact, that a membrane so delicate and thin that it is immeasurable by the most accurate micrometer, should resist so powerful a substance as iodine. If the

granules of starch are either triturated or immersed in hot water, the skin of the granules will be ruptured. Iodine will then turn them blue, and as microscopic objects they cease to be of value. This circumstance it is very important to remember; for in testing lichens and other low tribes of plants for starch by iodine, those parts which are inclosed in a membrane are not acted upon, and hence are inferred not to contain starch, while in reality they do contain that aliment. Starch is readily separated from wheat, potato, &c., by washing it in cold water. To obtain this proximate principle from rice, it is necessary to macerate it for a few days; and to prevent the decomposition of the gluten, a little soda should be added to the water. As microscopic objects the various kinds of starch are not only interesting on account of difference of size and form, but also as presenting, with polarized light, the beautiful phenomenon of the black cross. For this purpose it is well to select granules of *Tous les mois* (*Canna coccinea*) on account of their large size.

Under the microscope the surface of the grains often appear corrugated, and each of them has one or two bright spots; this spot is called the hilum, and is supposed to be the part where the starch adheres to the cell.

So important an amylaceous alimentary principle of respiration as starch, which enters so largely into the composition of the farinaceous articles of food, deserves to be minutely investigated.

It will be well for those interested in the purity of these

substances to have a collection of specimens of known purity from different plants mounted and labelled, so that they can readily compare with them any new and unknown kind of starch.

According to Berzelius, Iceland moss contains 44 per cent. of starch, while the tubercles of the potato only contain 20. The rhizomes of plants, as those producing the arrowroot, &c., average from 12 to 26 per cent. Seeds yield the greatest quantity; maize and rice containing 80, wheat-flour 70, and peas and beans about 30 per cent.

Tapioca and pearl sago, which during their preparation are submitted to heat, have their grains broken; hence they swell in cold water, and become blue with iodine, but are readily distinguishable under the microscope from other forms of starch.

The grains of starch form an excellent test, in the polarising microscope, of the axis of the polarising prisms; they require the line of collimation to be very true.—The magnifying power necessary for the examination of these grains is 150 diameters.—*Note.* In mounting these objects they must be protected from pressure; a thin paper should be inserted between the glasses.

*Sections of Wood* (recent).—The usual and common mode of examining microscopically the structure of wood, has been to cut a thin slice or section from the branch, and then view it as a transparent object. In this manner a variety of beautiful reticulated lacelike objects may be obtained, but little information is acquired of the

real structure of the wood. In order to understand the form and arrangement of the various parts, one vertical section is also absolutely necessary, if the tree is of the endogenous and branchless kind—which grow by additions to the interior; while if an exogen two vertical sections will be required in addition to the transverse one. The Exogens grow by annual layers exteriorly under the bark, and are branched. In the endogens it is unimportant in what direction the plane of the vertical section is made, providing it be parallel with the axis; but in the exogens one of the vertical sections should be *radial* and the other *tangential*. The *radial vertical* section exhibits the number and size of the medullary rays; that is, the small portions of pith which proceed horizontally from the centre, inclosed in a sheath of woody fibres. The frequency and size of the medullary rays determine the number and strength of the branches of the tree. This section also exhibits in coniferous trees the beautiful disc-like glands which adhere to the woody fibres. These are beautiful objects, and sometimes require a power of 200 to 300 diameters.

The *tangential vertical* section is a slice across the medullary rays; it exhibits the form and arrangement of the cellular tissue within them. All the vertical sections show the form, size and connection of the woody fibres. Spiral, reticulated and dotted vessels, &c., and are by far more instructive than the transverse ones. Of course in some kinds the vascular structure is not developed so much as in others: thus there may be an absence of



spiral or other vessels. It is clear from the above observations, that with three of these thin sections—the whole not weighing more than a grain—the growth and characters of a tree can be determined. Mr. Pritchard, who first introduced these thin sections as microscopic objects, says that he always arranges them in the following order: under the name—first, the transverse section; second a radial vertical section; third, a tangential vertical section. In the slides containing endogenous plants, there are only two sections—that immediately below the name—*transverse*, and the other *vertical*.

• *Teak, (Tectona grandis)*.—The wood of this tree is said to contain an abundance of silex, which may be tested by submitting a thin section to polarized light. To facilitate the operation of cutting thin sections of woods, it is usual to immerse them in such fluids as will dissolve out of them any hard substance; and where silica is present, caustic potash is employed to remove it. A specimen so treated will not, of course, depolarise light.

*Yeast Globules*.—It appears from Mr. Latour's microscopic experiments on fermentation, that yeast consists of a congeries of minute vegetables, which are propagated with amazing rapidity at a moderate temperature. See Phil. Journ. vol. xxv. (1838) p. 357.

*Organic Fabrics*.—There is a vast variety of articles of this nature, which not only possess much interest, arising from the methods by which the threads or bundles of fibres are woven or interlaced, but are of much importance in a useful, ornamental, and even commercial point

of view. With few exceptions, these articles are best examined as opaque objects on a black ground, under a magnifying power of from 30 to 60 diameters. In common muslins, linens, silks, and similar fabrics, the threads in both directions are similar, and those in one direction, (say the woof) pass alternately over and under each of those in the other direction (or warp). In ornamental fabrics the two sets of threads not only vary in colour, but often the threads in one direction are twisted more than those in the other; while a further variation is made, inasmuch as they do not pass alternately over and under those at right angles to them, but pass *over* two, three, or more threads, and *under* only one or two. By these means a pattern and a face are given to the goods. The manner in which these numerous and varied effects are produced is readily exhibited by the microscope under the powers before mentioned. The beauty to be met with in these examinations and the pleasure to be derived from them, are greatly heightened by selecting specimens of bright and varied colours, as plaids, checks, and striped goods.—*Note.* It is well to cut—or, what is better, punch out—a circular piece of the fabric, about half an inch or less in diameter, and mount it upon a black disc or in a wood slide.

Including nets and lace, there may be collected at least fifty varieties of interesting specimens of this class.

INORGANIC.—*Äërolites*.—Thin sections of these stones exhibit a beautiful radial structure.—They require a power of 30 to 80 diameters.

*Agate.*—This form of silica is often found imperfectly crystallized, and thin plates ( $\frac{1}{30}$ th of an inch thick), when viewed by polarized light, exhibit a rich motley colouring. In some specimens a tessellated structure is seen. The wavy lines which give the pattern are very fine and close together.

*Bismuth crystallized*—requires a very low power to show the regular rectangular form of its crystals. The colour of the surface when oxidated increases the interest.—Power 20 to 30 diameters.

*Borax crystallized in Glacial Phosphoric Acid.*—These crystals arrange themselves in circular masses or dodecahedrons composed of needle-shaped crystals radiating from the centre. These clusters exhibit the black cross and coloured rings when submitted to polarized light.—See *Microscopic Illustrations*, 3rd edition, page 227.

*Carbonate of Lime.*—Small spherules of this substance are sometimes found in the urinary deposits of the horse. These deposits are often composed of concentric layers; at other times the fibres are radial. Their diameter is about  $\frac{1}{200}$ th of an inch. There are several varieties, which should be numbered 1, 2, 3, &c. Illuminated by polarized light and a power of 100 diameters, they are splendid objects.

*Crystallization of Salts as transparent objects by common light.*—Independently of the beautiful geometrical forms assumed by different salts during their crystallization, a vast variety of elegant configurations may be obtained by mixing small quantities of the different solutions in a

little weak gelatine, starch, mucus, &c. For these experiments take a slide, and put one or two drops of a weak solution of gelatine upon it; then take one drop of some strong solution of salts, as Epsom salts, hydrochlorate of ammonia, sulphate of soda, tartaric acid, &c.; hold the slide over the flame of a candle until evaporation is perceived, when it should be removed and allowed to crystallize. If the evaporation is too rapid, the crystals will not be well formed. The main feature which distinguishes these preparations is, that the crystals are gracefully-curved figures, and not plain straight-lined boundaries. A magnifying power of 30 diameters is generally sufficient.

*Ice.*—A plan for observing the deposition of the particles of water during their solidification is as follows. Mix in some water a little charcoal, chalk, or other substance not soluble, in such a manner that a number of fine particles may be mechanically suspended in it: then take a large glass slide, place it on a cold night in an exposed situation, as the outside of a window-sill; then pour upon it as much water as it will support without running over the edge, and there let it remain all night. The next morning, if the weather has been sufficiently cold and the atmosphere dry, neither water nor ice will be seen on the slide; but the particles of charcoal will be found arranged in the various forms which they assumed while the water crystallized, and there remained after the ice had evaporated. The slide thus prepared may be kept for any length of time, if a slip of glass be

covered over it with some Canada balsam between the two.

*Iron.*— This metal as employed in the arts and manufactures varies very much in purity and quality. In some cases where great strength is required with a minimum of weight, it is important to select the hardest kinds the market affords, as for plough-shares, which when used on stiff soils are subject to great strain ; hence for these implements the Derbyshire iron is preferred. The hot blast iron, which has very inferior cohesion from its containing particles of carbon, is unfit to be used for cannon and similar purposes, but, being much cheaper than the other sorts, is sometimes substituted for the better kinds. To examine the quality of iron by the microscope a piece should be broken off, and its fractured surface, while clean and free from oxidation, submitted to that instrument as an opaque object. A strong light should be thrown upon it, and all the specimens should be examined under the same magnifying power. So important has a microscopic examination of this metal been deemed by the Government, that Her Majesty's Honorable Board of Ordnance have directed Mr. Pritchard to construct a microscope for the Arsenal at Woolwich.

*Iron, Elba.*— This ore, from the richness of the coloured oxides on its surface, and the grouping of its crystals, afford a good opaque object for a low power, say 30 diameters.

*Jasper.*— Of the several kinds of this stone, the agate jasper, when cut into thin plates about  $\frac{1}{30}$ th of an inch

thick, are by far the most interesting for the microscope. Some specimens are believed to be silicified sponge; indeed remains have been seen so perfect as to admit of identification and naming, as the *Dysidia fragilis*. The intense red colour of the fossilized parts, and the transparency of the colourless portions, (which latter affect polarized light), are well seen under a power of 40 diameters.

*Moss Agate*.—Thin sections of this substance afford interesting subjects for the microscope. The green earthy matter *Chlorite* is often diffused through it in such a manner as to resemble moss, and was supposed to be vegetable matter imbedded within it. In some specimens, parts of the silica take the structure of calcedony; these specimens should be viewed by polarized light.

*Oolites*.—Rocks are separable into two grand divisions, the Crystallized and the Stratified: the former (of which granite may be taken as an example) is the primitive formation, and must have been produced at a very high temperature. It varies greatly in hardness and durability: this arises from differences in the aggregation of the silica, felspar, and mica of which it is composed. In general, the most compact is that in which the plates of mica are smallest. This kind, however, which in other respects would be so desirable for building purposes, is so hard that the time and expense required in working it preclude its application to such uses. For the microscope a series of specimens from different quarries would be a valuable addition to a cabinet. There should

be two specimens of each, one with a fractured surface, the other smoothed and polished.

Stratified rocks are produced from the abraded particles of primitive rocks, the fragments of shells, coals, indurated clay, &c., deposited in sedimentary beds at the bottom of seas and lakes. They may be formed into five principal groups, viz.:—slates, sandstones, magnesian limestones, oolites and limestones. The sandstones employed for the erection of buildings contain about 95 per cent. of silica; the remainder being variable foreign matter, as oxide of iron, alumina, lime, &c. On minute examination, the quartz is observed in the form of grains cemented together by siliceous matter deposited by water that has percolated through them. They are usually laminated, and where mica enters into these compositions, the minute plates of that substance are disposed in layers. The cohesion and consequent durability of these stones depend upon the quality of the cementing substances, the grains of silica being themselves almost indestructible. The magnesian limestones, which are composed of carbonate of magnesia and carbonate of lime, when united in the proportion of their chemical equivalents, are valuable for building purposes. The principal stone used in the erection of the new Houses of Parliament is a stone of this nature from Austen.

The oolites or roestones are composed of about 92 per cent. of carbonate of lime. They consist of small spherical bodies united together by a calcareous cement. The size of the grains varies considerably. The largest,

called the Ketton oolite, is a beautiful object for the microscope. For building purposes those sorts in which the grains are smallest are preferred, as the Portland and Caen, the former of which was employed in the erection of Saint Paul's Cathedral, and the latter for the internal parts of the new Houses of Parliament. Some oolites are called *shelly*, from the number of shells and fragments which enter into their composition. In general these stones are not very durable, but for the microscope are especially interesting. The principal localities for obtaining them are Barnack, near Stamford; Box, near Bath; and Cranmore, near Doultling, in Wiltshire. In the oolites from the Trade quarries and the Grove quarry Bowers, at Portland, the shells are abundant.

Limestones are usually very fine-grained, and therefore not so generally valuable for the microscope as oolites. A collection of thin sections of these stones mounted as transparent bodies, together with two specimens of each, (the one with a fractured and the other a polished surface,) mounted as opaque objects, will convey to the observer much valuable information on the geological structure of these rocks.—Magnifying power 25 to 60 diameters.

*Sand.*—The sand (*Calcaire grossiere*) found at Grignon, near Paris, contains an abundant variety of fossil shells, many of which are both curious and instructive microscopic objects. They are best examined as opaque objects with a silver concave reflector.

*Sand, Bahama.*—The grains of this sand are of a globu-



lar or egg shape. Their colour is a pure white, and their surface so exquisitely polished, that a minute image of a candle reflected from their surface may be seen in the microscope.—Magnifying power 35 to 80 diameters.

The sand of the Arabian desert on minute examination is found to consist of small globular bodies of carbonate of lime similar to those grains which compose oolites. It is probable that the spherical form is given to them by abrasion against each other, caused by the winds ; and should at any future period water charged with lime pass over them, they may be converted into stone.

*Sand from Turkey Sponge.*—Under this name may be found a variety of minute fossils, some entire, others mere fragments. Among the most interesting are the Foraminifera, which resemble in miniature the chambered shells of the nautili, portions of small corallines, and other zoophytes.—A magnifying power of 80 diameters is sufficient.

*Sarde.*— The siliceous stone called by the ancients *Sarda* is found on the shores of the Red Sea. It is very hard, and is much valued by jewellers for seal-stones and ring-stones. Some valuable antique engravings are on *Sarde*. When cut into plates about  $\frac{1}{20}$ th of an inch thick, polished, and mounted upon a plate of glass, they form interesting objects for the microscope. In the light-coloured parts is sometimes seen a small spiral scroll-like form, with radiating striæ of calcedony around it.

*Water, Decomposition of.*—This phenomenon is admi-

rably exhibited under a low magnifying power on the screen of the solar or oxyhydrogen microscope; for which purpose proceed as follows:—Procure an aquatic slide whose sides are composed of two parallel pieces of glass two inches wide and four inches long; let the edges be of cement or some nonmetallic substance, so as to leave a space of  $\frac{2}{10}$ ths of an inch between them; let a piece of copper wire be fixed into each edge; then fill it with clear water, and place it under the microscope; lastly, connect the outer ends of the wires with a small galvanic trough. The evolution of gas from each pole or inner end of the wires will be shown on the screen by the image of the bubbles in the screen, which will descend (the image being inverted) in rapid succession—thus affording an interesting and instructive spectacle.

*Deut-Ioduret of Mercury.*—If a little of this intensely red-colored salt be placed in a watch-glass, with another inverted over it, and then the *lower one* heated over the flame of a spirit-lamp, the salt will be sublimed. Now place them on the stage of your microscope, armed with a power of 30 diameters and focus to the inner surface of the upper glass, when minute crystals will be formed thereon of a bright yellow colour, which as they cool return to the original red.

## CHAPTER III.

### TEST OBJECTS.

THIS important class of bodies—the properties of which were discovered by the late Dr. Goring—deserve special notice. It will therefore best serve the purpose of the Microscopist to insert here Mr. Pritchard's essay on this subject, as the "*Microscopic Cabinet*," in which it originally appeared, is out of print. To that essay will be added such discoveries as have been made subsequent to its publication.

“Every important advance in our knowledge of those bodies in the material universe from which our earth appears as an atom, has been coeval with and greatly dependent upon some augmentation of the powers and effectiveness of telescopes. Before the discovery of the double stars and nebulae, the goodness of these instruments was determined by their capability of showing the planets and their satellites. But since our acquaintance with the former bodies, telescopes have to undergo more severe tests, and greater accuracy in their construction is required. What has been advanced in regard to the telescope will be found also applicable to the microscope; and to the discovery of certain objects which may be considered

as tests of the *penetrating* and *defining* powers of this instrument we may justly attribute the grand and magnificent improvements which the microscope has recently received.

“ Before entering upon my subject, it will be proper to animadvert upon an error common to those who commence the study of microscopic subjects. To set out as they imagine fairly, they order an instrument to be so constructed as to show the various subjects of amusement of the larger kind, as aquatic larvæ, crustacea, beetles, cuttings of wood, scales of fish, wings, legs, &c. of insects, and numerous other objects of this class; and at the same time the microscope is expected to exhibit in perfection all the delicate minutiae in the structure of tissues, hair, blood, the organization of animalcules, the mosses, confervæ, and the scales of the insects of the orders *Lepidoptera*, *Thysanura*, &c. Now as this is almost impossible, (at least I can aver that I never yet saw one that was perfect in all these departments; and this position will I think be found correct, until systems of achromatic object-glasses of two, three, and four inches focus shall be made equally perfect with the deeper ones in all respects,) it is better to select an instrument that is efficient for those objects which are the immediate subject of our study, and to get it as nearly so in other respects as the constructions will admit. It is true, that in the single and double microscope, and also in the compound microscope, or engiscope, this can be very well accomplished by the addition of a number

of objectives and eye-pieces ; but even with these, if it is sufficiently small and delicate in its construction for the high powers, it will be too weak for the lower ones, and vice versâ. In short (to use an expression which has been applied to the telescope,) we may as well expect to have the properties of a high-bred racer and a heavy cart-horse combined in the same animal, as the union, perfect in one instrument, of the capabilities I have described.

“This chapter, be it remembered, is devoted more especially to the investigation of the deeper and more powerful class of microscopes and engiscopes.

“In the perusal of the works of Leeuwenhoek, Dr. Goring met with a passage describing the dust or imbricated scales which cover the wings of the silkworm (*Phalena Mori*), from which he was led to suspect there were some peculiar properties in the lines on the feathers and scales of insects, rendering them more difficult to be discerned than other microscopic objects ; and the result of his investigation was the discovery of their properties as TESTS—a description of objects before unknown in the annals of microscopic science.

“Now it is undoubtedly of the highest importance to the naturalist that he should know the exact capabilities of his instrument, in order that he may not be led astray in his investigations by placing undue confidence in it ; and as these tests offer the best means of accomplishing this end, I conceive them to be of the highest value and interest.

“The passage which I believe led the Doctor to the discovery alluded to is here transcribed:—‘If we examine the wings of this creature (Silkworm Moth) by the microscope, we shall find them covered with an incredible number of feathers, of such various forms, that if a hundred or more of them were to be seen lying together, each would appear of a different shape. To show more clearly this wonderful object, I caused eight feathers to be delineated; for I do not remember that I ever saw them of so curious a make in any flying insect. Although the microscope by which these feathers were drawn represented objects very distinctly, the limner could not, through it, see the ribs or streaks in each feather until I pointed them out to him. Therefore I put into his hands a microscope which magnified objects almost as much as that by which the silkworm’s thread was drawn, desiring him to give the figure of that feather which through it he could see the most distinct.’—*Selec Works*, p. 63.

“In this passage one point is very remarkable; namely, the incapacity of the artist to see the object unless a higher power was used than that which Leeuwenhoek employed.

“Having ascertained that different test-objects require different degrees of perfection in the instrument used to develop their structure, it became an interesting pursuit to discover those which are best adapted for this purpose, and the peculiarities in the illumination, &c., under which they are exhibited with the greatest perspicuity. In this investigation, it was found that there were two distinct

properties in a microscope, and that the instrument might possess a very considerable approximation to perfection in the one, and fall short in the other, or *vice versá*, or might be perfect in both. The lines on the dust or feathers from the wings of the Lepidoptera, and those on the scales from the body and limbs of the Thysanuræous insects, offered the means of determining their goodness in one particular, namely, their penetration; while the structure of the hair of animals, certain mosses, &c. served to ascertain their *defining power*.

“The analogy between telescopes and microscopes is so great, that I cannot be said to digress from my subject in stating that the aforesaid observations apply also to the former of these instruments, which seldom combines the two qualities of penetration and definition to any great extent. Thus a telescope with a large aperture will frequently resolve clusters of stars and exhibit nebulæ, while it will fail in defining the disc of a planet, or the moon, with precision; and on the other hand one of moderate aperture accurately figured will define the latter, but be wholly inert on the nebulæ and clusters. So a microscope with large aperture and high power will show the ‘active molecules’ and lined objects, while it will not define a leaf of moss, or a mouse-hair; and another with a smaller aperture will define the latter, but prove ineffective on the former. This is very manifest in single lenses,\* which require different apertures for different objects.

\* “I have a very beautiful sapphire lens (plano-convex of one-

“The penetration of a microscope has been shown\* to be dependent on its angle of aperture, and that whenever this was less than a certain quantity, the lined structure of the scales cannot be rendered visible, however perfect the instrument may be, and the defining power is inversely as the quantity of spherical and chromatic aberration.

“In order to effect the union of these two properties it is requisite not only that the aberration be destroyed for a central pencil of rays, but that the whole of the pencils within the field of view should be nearly perfect; and it is, I conceive, from this cause that no single lens, or single object-glass, however perfectly achromatic or aplanatic, will so far define an object that the lines and outline shall be distinct at the same time—a property I have only seen in sets of achromatic object-glasses.

“A proof or test object may be defined to be one which requires a certain degree of excellence or perfection in a microscope or engiscope for the development either of the whole or some particular part of its structure. Test-objects are separable into two great divisions; but as I intend only to treat on one of them, it is proper here to point out their distinction. In the first division

fifteenth focus) that shows the lines on the long brassica very distinct and sharp, when its aperture is large, but will not define a moss satisfactorily with this aperture; but as stops behind the object have the effect of reducing it, with them it shows the latter.”

\* See introductory chapter to the third edition of the *Microscopic Illustrations*.



I place those which operate out of focus and tell us *what* the defects of an instrument are ;—in the second, those which, if exhibited by a microscope, assure us that it possesses certain good qualities. The first division, as artificial stars, enamel dial-plate, wire-gauze, &c.\*—which informs us of the state of their aberration, achromatism, centering, adjustment, curves, &c.—I shall pass over, as many persons are not disposed to enter into a scientific scrutiny concerning the causes of their demerits, and because they are more applicable to engiscopes or compound microscopes, than to single and compound magnifiers ; and shall content myself by giving some simple means of determining effectiveness by means of the second division.

“ Before describing the lined test-objects individually, I should notice that they differ much in the facility with which they are resolved. Some are just made out by an ordinary microscope ; while others require the most perfect instrument and precise tact in the management of the illumination. It will be proper, therefore, to divide them into classes ; the first containing such objects as are most easily resolved ; the second, such as require an instrument having very clear and distinct vision ; and the last, the most difficult to which the powers of a microscope can be subjected, and requiring the most rigorous perfection in every respect for their resolution. When an

\* For a particular account of these objects see Dr. Goring's Memoir “on the Exact Method of &c.” in the *Microscopic Illustrations*, 3rd edition, page 264.

instrument shows the last class properly, it may be at once pronounced superlative. So difficult are some of these, that I do not know of half-a-dozen engiscopes or microscopes that will exhibit them satisfactorily.

“There are generally some very easy scales and feathers among samples even of the most difficult kind. I must therefore strongly impress upon the observer the necessity of a careful selection. And here I may notice that the darker the specimen the easier it is made out, and, in general, the black ones are no proofs; while, on the other hand, the more transparent the tissue, the greater the difficulty there is in developing its structure. Another point I shall dwell upon is their proportions, or the length and breadth of the object; for in some cases the narrow long specimens are very difficult, while the short broad ones are very easy.

“The study of the manner in which these subjects are exhibited is also of paramount importance; for in proportion to the excellence of the instrument will the darkness and blackness of the lines be increased and the transparency of the spaces between them augmented; therefore, in comparing two instruments of the like construction on the same object and under similar illumination, I should say that which shows the lines blackest and the spaces most transparent is the best. In this comparison I assume as a matter of course that their magnifying powers are to be equal. The instruments should also be of the same optical construction, or the experiment will be unfair, for I have observed that in

instruments of different kinds, all equally perfect, the doublet (with Dr. Wollaston's illumination) shows them palest; next come single lenses and the achromatics, and lastly the reflectors.

“In selecting a test for comparing the performance of two instruments, it is best to employ one that can be resolved by both of them, otherwise you have no measure of their relative value; and remember that the illumination is properly conducted with each, otherwise a good microscope may be rejected, and a worse one, by better management, allowed to carry off the palm of victory; for with difficult objects the illumination requires the utmost tact. I have seen artists with instruments of the very first quality spend much time before they could exhibit an object, which at other times they have shown *instantanter*.”

“The following objects I have selected for tests, being easily procured. They are arranged somewhat in the order I have proposed; but it is difficult to divide them with precision, owing to the diversity of specimens from different subjects of the same kind.

## PENETRATION.

### FIRST SECTION (Easy).

Scales of *Lepisma saccharina*.

————— *Petrobius maritimus*.

## SECOND SECTION (Standard).

Feathers of the *Morpho Menelaus*.

————— *Alucita pentadactyla*.

————— *Alucita hexadactyla* (from the body).

————— *Lycæna Argus*.

————— *Tinea vestianella* (from under side of the wing).

## THIRD SECTION (Difficult).

Scales of *Lasciocampa Quercus*

————— *Janira Aira*.

————— *Acromycta tridens* (Dagger Moth).

————— *Podura plumbea*.

Feathers of *Pieris Brassica* (Cabbage Butterfly).

Flutings of the shells of certain Fossil Infusoria.

## DEFINITION.

Hair of Mouse (*Mus domesticus*).

————— Bat (*Vespertilio murinus*).

Moss leaf of *Hypnum* (species unknown).

*Lycæna Argus* (spotted scales).

(1.) “*Lepisma saccharina*.—The insects of the families Lepismenæ and Podurellæ are comprehended in the order Thysanura of Cuvier. They are small, frequenting damp places, and are of various colours; they leap like fleas.

“The scales of these apterous insects must be taken from fresh specimens; for when long dead they adhere so firmly to the insect that they cannot be detached without injury.

“Their longitudinal lines slightly radiate from the point of insertion; they are readily seen, and appear flat or square, like the indentations on some bivalve shells; these are the prettiest scales I am acquainted with. There are other lines in various directions. When

the candle is so placed as to bring out the latter strongest, and the scale is turned round in the axis of the microscope in certain positions, they will cease to appear connected. In this object it is the sharpness and clearness of the spaces that chiefly evince the goodness of a microscope; for the longitudinal lines are easily developed. Another species of this family (*Lepismenæ*)—namely, the *Petrobius maritimus*—found under stones near the sea coast, has longer scales than the former, and very strong cross striæ, which afford excellent common tests.

(2.) “Scales of *Morpho Menelaus*.—This butterfly is indigenous to America; the wings are indented, and their superior surface of a highly-polished blue colour.

“The imbricated scales from the centre of the superior side of the wing are of a pale blue, mixed with others almost black. The former are mostly broader than the latter, and are the test-objects required; they measure about the one-hundred-and-twentieth of an inch in length. When viewed under a microscope they exhibit a series of longitudinal stripes or lines. Between these lines are disposed cross striæ, which with the lines give it the appearance of brickwork.

“The microscope or engiscope under examination should be able to make out these markings with the spaces between them clean and distinct. The cross striæ which give the brickwork appearance are seldom to be seen all over the feather at once. The tissue that covers this scale or feather contains a large portion of colouring-matter, and is often destroyed in removing the scale from the wing,

and along with it the cross striæ. In such cases the longitudinal lines only can be visible. The damaged specimens are easily known by their paleness.

(3.) “*Alucita pentadactylus* and *hexadactylus* (the Ten-plumed and Twenty-plumed Moths.)—The structure of the wings, or more properly plumes, of these insects, is so peculiar that few persons acquainted with Entomology are strangers to it.

“The Twenty-plumed Moth is more delicate in its form than the other. The feathers or scales employed as proof-objects must be taken from the body of the insect, and not from the plumes or wings. Their breadth is generally greater than their length, and their form is never symmetrical. They are transparent and about the one-hundred-and-eightieth of an inch long. The scale is often partially covered by a delicate, uneven, membranous film, which obliterates the lines on those parts. The longitudinal lines are not difficult to resolve; but their proximity is such that they require a considerable power and careful illumination to separate them distinctly. They are elegant microscopic objects, but rather scarce.

(4.) “The *Lycæna*.—The feathers of all the species of these small butterflies are charming subjects for the microscope, the studded blue (*Lycæna Argus*) in particular. As proof-objects the lined specimens have nothing remarkable; those from the inferior side of the wing are of a bright yellow colour, and the spaces between the lines very transparent. The spotted scales found along with these will be noticed hereafter.

(5.) “The *Tinea vestianella*, or Clothes Moth.—These small brown moths possess very delicate and unique scales, requiring some tact in the management of the illumination to resolve their lines distinctly. I should observe that it is the small feathers only, from the under side of the wing, that must be considered as tests; the others are easy. This is a favourite object with some who exhibit it as the standard of excellence. I do not consider it very difficult, though it must be admitted that to bring out the lines sharp and clean requires an excellent instrument.”

(6.) The scales of the *Lasciocampa Quercus* (*Bombyx Quercus*) are stated by some observers to have triple lines, the centre one much stronger than those on each side. The scales for these observations must be taken from the margin of the under wing of the male moth.

(7.) “*Pontia Brassica*.—The pale slender double-headed feathers, about one-eightieth of an inch long, having brush-like appendages at their insertion, obtained from some portions of the wing of the large Cabbage Butterfly, afford an excellent criterion of the goodness of a microscope. Some connoisseurs prefer them to all others, and form an accurate judgment of an instrument by the manner in which it demonstrates this single object. They are easily detached from the wing by the point of a quill, but must be gently handled, for, like many others, they are soon mutilated; indeed I have seldom seen them perfect in the ordinary sliders. Those specimens which are easily resolved are readily distinguished, being short, broad,

and more opaque. There are also found on the same wing two or three other sorts, but they are unworthy of notice as proof-objects.

“ There exists in the minds of some observers a doubt whether there really are any lines on this scale. Professor Amici says they are strongly hygrometrical, and when perfectly dry no lines are to be seen, but when moistened by breathing upon them the lines appear.

(8) “ The *Podura plumbea* (Lead-colour Springtail.)— As before noticed, these insects belong to the same order as the *Lepisma*. They are about the tenth of an inch long, and leap about like fleas (*Pulex irritans*), though not so high. They are found among sawdust and damp wood, abounding also in wine-cellars; they are very active, and consequently difficult to catch. They may be taken by the following method. Sprinkle a little oatmeal or flour on a piece of black paper, and place it near their haunts; after leaving it a few hours in the dark, the paper must be carefully placed in a large glazed bason, so that when they leap from the paper, on being brought into the light, they may fall into the bason, and thus separate themselves from the bait. The body and limbs of these insects are covered with scales, which from their extreme delicacy require great care in removing. They are also very soft and easily wounded. The fluid which exudes from the injury, so completely adheres to the scales as to obliterate all their markings. Hence they must be cautiously handled. Those who are desirous of preserving these insects should keep camphor along with



them; through omitting this I once had a large collection of them consumed by a species of mite which had insinuated itself into the box.

“ I have never been able to see the markings on them with a power much below 250, (that is,  $\frac{1}{5}$ th of an inch focus,) and therefore microscopes of a lower power cannot be expected to show them, except of a very superior quality; for it must be constantly kept in mind that that instrument is the best which exhibits an object with the least amplification, all other things being equal.

“ It is also proper to notice, that single magnifiers will resolve them, but not unless considerable attention is paid to their illumination. Good doublets of sufficient power show them readily with Dr. Wollaston's illumination; but they are most easily made out by the simple light of a candle in the achromatic microscope, if it possess an angle of aperture of about fifty degrees, exhibiting all their delicate minutiae with precision.

“ It is affirmed by a very acute experimenter of these scales, that ‘ all are difficult, and some seem to defy all power of definition.’ The latter part of this quotation is perfectly accurate; but I differ from the former, inasmuch as many specimens, especially the French ones, are very easy, and unworthy the title of proofs; and as they might be substituted for those I am describing, and thus a common instrument might pass for one of superior excellence, I feel justified in giving this caution. The size of these scales varies from one nine-hundredth to the one hundred-and-sixtieth of an inch in length, and as they decrease

in size they become more transparent. They are of different forms, but possess a general character easily recognised by the want of any sharp angles. Under a microscope not having sufficient penetration, the tissue appears devoid of structure or markings; but when placed under a superior one, and the illumination properly made, they show a series of lines or cords on their surface, and present a much greater variety in their arrangement than the scales of any other species of insect. Some have the lines straight, others are waved and curved, while on some of the small ones nothing satisfactory has yet been developed." Their most usual appearance, however, is, that of spines, arranged in various forms upon the surface of the scale. Some observers consider that the scale is covered with short hairs; but the investigations of Mr. Pritchard leave no doubt of their being lines.

"As a general rule, it will be found that the smaller the scales the more difficult the test. I must not omit to notice that the cords on these scales are loosely attached to the tissue, and are often rubbed off in mounting. Of course it will be fruitless to examine such specimens."

"Before leaving the subject of the lined objects, I should notice, that all objects of similar structure are more or less tests, as the lines on the scales of some beetles, especially those from the Diamond Beetle (*Curculio imperialis*). The scales from the body of this Beetle, either as transparent or opaque objects, are by far the most brilliant, in point of colour, of any of the lined class. In viewing

them as opaque objects, in order to exhibit the lines, the scale must be brought a little within the focus, and the illumination carefully arranged. As transparent objects, they are much more easily managed. They present a mottled sort of colour, composed of the brightest carmine, mixed with purple, blue and yellow, and their lines are distinctly seen. As the lines on some of these scales are of easy resolution, it will not be advisable to trust every specimen as a test. The small ones from the legs of the Brazilian Beetle are the most difficult, and many of these require the most rigid adjustment of the focus and illumination to resolve the lines; and the slightest tremor, though not enough to occasion any sensible dancing, (as a carriage at a distance,) is sufficient to render them invisible.

“The lines and markings on certain vegetable tissues, and many others too numerous to name, may also be employed as proof objects. The reason for making a selection of those above described, has been, in order to render the task of judging of the merits of an instrument by different individuals more simple and satisfactory.” The scales from the wing of the *Papilio Janira* are esteemed by Professor Amici as difficult test-objects. The same distinguished microscopic observer considers the lines on the scales from the margin of the under wing of the male *Lasciocampa Quercus* very difficult of resolution. When the penetration of the microscope is sufficient, the lines appear triple. This appearance is probably due to their tubular structure.

The flutings of the shells of some of the Bacillaria Infusoria, as the *Navicula Hippocampus*,\* are among the most difficult test-objects discovered; they require a power of 400 diameters to bring them out distinctly.

“ The defining power of microscopes and engiscopes depends on their capability of collecting together all the rays from any one point of an object—or, in other words, their freedom from aberration—and is independent of their penetration; for, if we take an engiscope, and view a lined object with the aperture of the objective as it is usually sold, its defining power may be very fair; but if we enlarge the aperture so as to enable us to develop the lines—which it will then accomplish—the defining power of the instrument will be injured to such an extent as to render the outline confused. The great desideratum, then, in microscopes and engiscopes, is to obtain these two qualities combined; which, however, is only rarely attained.

“ Cylindrical or spherical bodies appear the best suited for ascertaining the goodness of an instrument as regards definition; and the following examples, which are prefaced by remarks on the method of illuminating them, I deem sufficient for this end.

“ In the preceding class of objects, oblique diverging rays appear to be essential for the development of their structure; the degree of obliquity varying, however, with different lined specimens. The extremes of this variation are the *Podura plumbea* and *Pieris Brassica*, the delicacy

\* History of Infusoria, page 207, fig. 145.

of the former requiring almost central light, while the latter requires it very oblique. From this cause artificial illumination is to be preferred to daylight for this class of objects, as the light of a lamp or candle gives the rays diverging without any apparatus whatever. The same effect, however, may be produced in daylight, either with Dr. Wollaston's or Dr. Goring's illuminator, where the rays after meeting at the focus of their illuminating lens are permitted to diverge, and by placing the object out of the centre oblique vision is obtained.

“ In the investigation of the class of objects now to be described, direct parallel rays are preferable, and indeed in most cases are essential; and on this account they are scarcely ever well defined by simple candle- or lamp-light. In these, therefore, a clear daylight, directed through the axis of the instrument, should be employed.

“ In the selection of the hair of animals for microscopic examination, either as opaque or transparent objects, the lightest-coloured ones should be preferred, as they permit us far more easily to observe their internal conformation, while the colouring-matter (*rete mucosum*) in some hair is so considerable as to render them incapable of transmitting the most feeble ray, and these are therefore unfit for this purpose unless mounted in Canada balsam. Those on the inferior side of such animals as the mouse, dog, &c., should be on this account selected. Like the scales on insects, the hair from different parts of the same individual varies considerably in structure.

“(1.) The hairs of the Common Mouse (*Mus domesticus*)

differ both in size and form. Under the microscope, they should have their transparent parts clearly and distinctly separated from the darker portions. This remark holds good for the whole tribe of hairs and mosses, and it is from the sharpness with which the parts are separated that a correct opinion of the goodness of an instrument can be obtained. When these hairs are seen by reflected light, that is, as opaque objects, their appearance is altered, the dark solid parts reflecting more light than the transparent portion; hence they are lighter than the latter.

“The diameter of the mouse’s hair varies from one two-thousandth to one three-hundredth of an inch; they do not require a high power to see them.

“(2.) The hair of the Field Mouse (*Mus sylvaticus*) possesses a structure totally different from the former species, and is a good microscopic object.

“(3.) The hair from the wing of the Bat (*Vespertilio murinus*).—Although this creature is supposed to bear some affinity to the mouse, the structure of the hair of these two animals is entirely different. There are, however, great varieties; some are spiral, others like a succession of cones, the apex of one being inserted into the base of the following.

“(4.) The *Lycena Argus*.—Among the scales on the under side of the wing of this elegant blue Butterfly are some whose conformation is remarkably singular: their general appearance is not unlike a child’s battledore with its surface covered with spots. I have not been able

satisfactorily to demonstrate its structure ; but it appears to consist of two delicate tissues having regular rows of conical spines on the upper one. As a test-object these spots should be clearly and distinctly separated." The spots on the "hen-coop" scales, when viewed under a very deep power, appear quadruple ; each spot, including the four, measures  $\frac{1}{10000}$ th of an inch. "When the light is thrown obliquely, they are blended together, appearing like a stripe of unequal breadth. Similarly to many of the other tests, it is the manner in which they are seen, rather than the mere exhibition of them, that should be observed. This object I employ for the same purpose as the leaf of an unknown species of moss belonging to the genus *Hypnum*, which, as it is difficult to procure, renders this substitute an acquisition to the microscopist."

*Note.*—With respect to illumination, "the reader should observe that *quantity* and *intensity* are distinct from each other ; thus when we employ a small wax taper close to an object, it will be intensely illuminated though the quantity of light is small ; but if we employ the flame of a large lamp, &c. at some distance from the object, its intensity will be small though the quantity of light be great. It will be found generally preferable to employ a small quantity of intense light rather than a larger portion of weak light, and, if possible, avoid the use of lenses or mirrors either for condensing or changing the direction of the light. This remark applies especially to the verification of an object.

“ *Hints on the Nature of the Markings on the Scales from the Podura plumbea and Pieris Brassica.* ”

“ In the foregoing account of the different scales from the wings and bodies of insects, the design has been to describe their appearance under microscopes, without in the least determining their actual structure. When it is considered that these lines are less than one twenty-thousandth of an inch distant, it must be allowed there is some difficulty in accurately determining their construction.

“ The *Morpho Menelaus* and *Lepisma saccharina* are of sufficient size to enable us distinctly to perceive that they are composed of two delicate tissues with longitudinal cords (probably tubular) disposed between them ; but in the two delicate ones, the subject of these remarks, we perceive other systems of lines disposed obliquely ; and as they are extremely delicate, it becomes a question whether they actually exist, or whether they are appearances produced under certain modifications of the illumination. As there is only one set shown at a time, and I have never been able to see them in a decided way, I have been induced to consider them as appearances only, and not real lines. To determine this point it became necessary to ascertain the cause which would produce such an effect ; and it immediately occurred to me that these oblique lines were occasioned by the disposition and pressure of the superambient scales, in the same manner as the watering or wavy appearance communicated to



corded silks and moreens by the pressure of two pieces passed between rollers." There can be no doubt now, that the spine-like markings on the scales of the Podura are in fact impressed portions of the lines. The very perfection of a microscope in giving distinct vision only in one plane at a time is liable to occasion an erroneous idea of an object, if not taken into account; and this is one example.

## CHAPTER IV.

### ANIMALS AND PLANTS IN WHICH THE CIRCULATION HAS BEEN OBSERVED UNDER THE MICROSCOPE.\*

“THE most interesting active phenomenon exhibited by the Microscope is the circulation of the nutritious fluids in animals and plants. In the former the corpuscles of blood may be seen passing rapidly along the capillary ends of the arteries into those of the veins, when the intervening membrane is sufficiently diaphanous, as in the ear of the young mouse; the fins and tail of the carp, gold-fish, stickleback, tadpole, and of most small fish; and in the web between the toes of the frog, lizard, eft, &c. For these purposes a magnifying power of from 100 to 200 diameters is sufficient.

“In the Arachnida (Spider tribe), at the joint of the legs I have observed the circulation very distinct, the current of dark globules passing rapidly at each pulsation of the dorsal vessel. In the antennæ and wings of terrestrial insects, it has also been seen when they have just emerged from the chrysalis, as in the *Perla viridis* and *Semblis bilineata*. In several aquatic larvæ and

\* Extracted from Mr. Pritchard's List, p. 21.

small Crustacea, the circulating fluid traverses the limbs, antennæ, and tail, and thence moves along the dorsal vessel towards the head and down the sides of the body in cavities and not distinct vessels, hence called diffused circulation. The most favourable subjects for viewing this are the following, the first six of which are drawn and described in the 'Microscopic Illustrations' and 'Cabinet':—Larva of the Ephemera—(The recent discovery of the beautiful mechanism of the dorsal vessel of this larva by Mr. Bowerbank is fully confirmed by the careful dissections of Mr. Newport, who with much perseverance has extended these inquiries to the other states of insects;)—Larva of Hydrophilus; small Dytiscus; *Agrion Puella*—(In this elegant larva I have not observed the circulation in the legs to extend beyond the haunches; ) Libellula; round Lynceus; freshwater Shrimp; Water-hog (*Oniscus*); *Ligia*; Water-flea (*Daphnia Pulex*), &c. Power 100 to 300 times. In several of the Polypiferous Zoophytes, as the *Tubularia indivisa*, Sertulariæ, Campanulariæ, Plumulariæ, &c., Mr. Lister has by means of the achromatic engiscope discovered a circulation to exist which in many respects resembles that in plants.

“The circulation in plants termed *cyclosis* is a revolution of the fluid contained in each cellule, and is distinct from those surrounding it. It can be observed in all plants in which the circulating fluid contains particles of a different refractive power or intensity, and the cellules are of sufficient size and transparency. Hence all lactescent plants, or those having a milky juice, with the other conditions,

exhibit this phenomenon. The following aquatic plants are generally transparent enough to show the circulation in every part of them:—*Nitella hyalina*, *Nitella translucens*, *Chara vulgaris*, and *Caulinia fragilis*. In the Frogbit (*Hydrocharis*) it is best seen in the stipulæ of the leaves and the ends of the roots. The magnifying power suited for the above are between 60 and 200 diameters. In the Spiderwort (*Tradescantia virginica*) it is seen in the bead-like filaments surrounding the stamens of the flower. Power 300 to 400 diameters. In the Common Groundsel (*Senecio vulgaris*) it is said to be seen in the hairs surrounding the stalks and flowers. In the *Valisnaria spiralis* circulation may be seen in sections of the leaf.”

Among Infusoria the genera *Closterium*, *Navicula*, and *Euastrum* exhibit a curious circulatory motion.

*Ciliary Currents.*—The respiratory organs, or more properly the organs for aëration of the circulating fluids, in the Mollusca and some other classes of animals, are furnished with cilia. These cilia (which resemble very minute eyelashes, from whence their name is derived) form a fringe around the bronchi, and are in constant motion; the purpose of which is to bring a fresh supply of water into contact with the organ by which the oxygen is obtained. The exhibition of this process yields to none in interest, except indeed the actual circulation of the vital fluid itself. For observing this phenomenon, arm your microscope with an object-glass of one third of an inch focus, the power being about 100 diameters. Take

a common or native oyster, or a muscle, just opened, and cut off a small portion of that part commonly called the beard; a piece about a quarter of an inch over is amply sufficient. Place this in an aquatic live-box with a little of the liquor of the oyster or salt and water, taking care to have only one lamina, and spreading it out flat; then put the cover on. Now place it under the microscope, adjust to focus, and let the edge of the beard pass across the middle of the field of view, when the currents will be distinctly observed. A little indigo mixed in the water enables the currents to be better observed, but they will not continue so long as without that coloured material. The motion will often continue for more than an hour after the specimen has been separated from the animal. The vision is much improved by the judicious introduction of stops or diaphragms under the object and stage. On the subject of viewing the currents in Fluids during their evaporation, see 'Microscopic Illustrations,' page 143.

## CHAPTER V.

### ON VIEWING MICROSCOPIC OBJECTS BY POLARIZED LIGHT.\*

“THE addition of a polarizing apparatus to a microscope will be ere long considered as an indispensable accompaniment to that instrument, whether we consider its peculiar properties or the brilliant colours it gives to all bodies affected by it. The apparatus which I have contrived for this purpose is extremely simple, and may readily be attached to, or removed from, the microscope without either disturbing it or the object under consideration. It consists of two small tubes, containing single-image calcareous prisms, or plates of tourmaline; one of which is placed under the stage of the instrument, and used in the same manner as Goring’s illuminator or plain diaphragms.—(See ‘Microscopic Illustrations,’ new edition, p. 111.)

“An intense light is to be directed through it, and the instrument adjusted to the object in the usual way. The object will present the same appearance as without the polarized or lower prism. If, however, a second tube

\* Pritchard’s List, page 19.

with a prism be screwed immediately behind the object-glass of the microscope, (that is, between it and the body,) the object will appear of the most brilliant colours if affected by polarized light.

“When an object under examination exhibits the colours by depolarizing the light, if the field of view appear luminous, as in viewing transparent objects by common light, cause the lower prism tube or polarizer to revolve, and in certain positions the field of view will appear *black*. The objects now assume the colours complementary to those which they had upon a bright ground; indeed their appearance is that of brilliant gems lying upon black velvet. Many crystals exhibit these polarized tints very intensely. The following crystallized on a slip of glass I have found remarkably interesting both as regards the elegance of their form and the splendour of their colours:—salicine, chlorate of potassa, oxalic acid, prussiate of lime, nitrate of potash, and acetate of copper.” To these may be added the crystals and minerals named in the Catalogue under this heading, especially the xanthate of ammonia. “The great advantage of employing the microscope in viewing the polarized tints of bodies, is, that very small specimens will answer equally well with larger and more expensive ones in the ordinary way, while they do not require any troublesome process to split or cut them into different thicknesses for obtaining the different tints, this being accomplished in the process of the crystallization.

“*Sulphate of Copper*.—This salt, which is of a fine blue

colour when viewed in considerable thicknesses, is white and transparent when it is extremely thin, and its crystals can be procured so small as to be quite destitute of perceptible colouration. A drop of it was placed upon a warm piece of glass and suffered to evaporate gradually. The crystals, shooting out from the edge of the drop into the interior of the liquid, had a long and narrow rectangular form with a slanting extremity, which may be compared in shape to the straight edge of a chisel. Seen by common light these crystals offer nothing peculiar, but on the darkened field of the polarizing microscope they are luminous and splendidly coloured, the colours depending upon the thickness of the crystal, and being the same in all points of its surface, except upon the little inclined plane which forms its extremity; but upon oblique portions are seen three or four bands of colour parallel to the edge and offering to the eye a visible scale or measure of the rapid diminution of thickness in that part. The observed succession of colours in one experiment was the following:—yellow, brown, purple, blue, sky-blue, straw-yellow, pink, green, pink, blueish green, pink. Sulphate of copper, with a drop of nitric ether added to the solution, on a slip of glass, produced minute crystals in the form of rhomboids. These when placed under the microscope with the field dark, appear like an assemblage of brilliant rubies, topazes, emeralds, and other gems, each being of a different thickness, depolarizing the light in a different degree. If the polarizing eye-piece be now turned a quarter round, the



field becomes luminous and the crystals assume the complementary colours. Many other salts offer interesting results. Some, however, crystallize in such thin plates that they do not sufficiently depolarize the light to become visible on the dark ground, such as the minute crystals of sulphate of potash precipitated by ether, but even these may be often rendered visible when placed on a plate of mica.

“The beautiful property of dichroism discovered by Sir D. Brewster in acetate of copper, may also be exhibited without any trouble with the polarizing microscope.

“Many organic substances appear luminous when the field is darkened; while others are inert, having no sensible action on the polarized light.

“Fragments of coarsely powdered sugar and of various salts appear more or less bright and mottled with various colours. Common salt remains dark, and does not act upon the light.”

In the general Catalogue, a number of objects, such as quill, sections of hoof, nail, whalebone, carbonate of lime (animal deposit), &c., will be found interesting for the polarizing microscope. The placing a thin section of selenite or of quartz under the object, as recommended in the ‘Microscopic Illustrations,’ as also the employment of a double image prism for the analyser or upper prism, will often increase the variety and beauty of the colours.

*Plants to be viewed by Polarized Light.*—Many plants secrete or deposit on the surface of their stems or

cuticle silica or flint. This is especially the case with Graminaceæ. In wheat and barley straw the quantity is small; in the bamboo it is much larger, and a siliceous body, containing a little lime and vegetable matter called *tabasheer*, so remarkable from its slight refractive power, is secreted in the joints of that cane.

The polishing quality of the rush arises from this deposit.—To prepare these bodies for the microscope, it is necessary to make thin slices of the cuticle; and if they are not sufficiently transparent, immerse them in Canada balsam between two slips of glass. The magnifying power required for these examinations varies greatly according to the size of the particles deposited, and therefore cannot be stated with advantage.

## CHAPTER VI.

### ON PREPARING OBJECTS FOR THE MICROSCOPE.

THE first requisite is to select perfect specimens of the various objects to be mounted. By the term perfect is here to be understood specimens which have not been mutilated nor undergone decomposition. The next requisite is to collect the largest and most highly developed specimens. In the lower tribes of animals there are often great diversities in the forms of different individuals of the same species : hence it is necessary that we be well assured that we are examining a normal specimen before coming to any conclusion thereon. This is also very necessary before making drawings of microscopic objects ; and the want of such precaution has led to the publication of many erroneous descriptions.

Again, in order to unravel the true form and structure of a minute body, it is absolutely necessary that the organs to be examined be perfectly developed ; otherwise it will be difficult, if not impossible, to understand correctly the functions performed by such organs.

Due regard being had to the above directions, the skill and labour of the preparator will not be wasted. It not unfrequently happens that specimens of certain objects

are very rare, and thus we have little choice in the selection. When this happens, it is always wise to commence our operations on the most defective and conclude with the perfect. By this means we shall acquire facility and experience, which will be more profitable as we proceed.

In this little work the principal points to be attended to will be given; but so numerous and varied are the subjects for the microscope, that it will be impossible to meet every individual case that may occur. An attentive perusal of this work and the 'Microscopic Illustrations,' with a few days' practice, will enable the student in these matters to overcome most of the difficulties, and to furnish himself with a collection of objects that will afford an endless variety of subjects for investigation and contemplation.

*To Clean the Specimens.*—If the object is to be mounted whole, the first process is to thoroughly cleanse it. This is done either by brushing it with a camel's hair pencil or washing in water or turpentine. If it be a hard and brittle creature, it must be soaked in hot water; and as fresh insects contain much fat, a little caustic alkali should be added. When thus softened, the insect, if intended for an opaque object, is to be spread out on a piece of cork and held in a proper position until dry by means of small pieces of card pinned down to the cork; these pins and card are called by entomologists *braces*. When the specimen has hardened, the braces can be removed, and the object is ready to be fastened by gum or cement to a disc, which will be described in a subsequent page.

If the subject is to be mounted as a transparent object, as soon as soft it must be laid on a slip of glass and spread out; it is then to be covered with another slip of glass, and the two bound together by thin twine. In this condition the object must remain until quite dry, when the slips of glass are to be separated. It is now ready for mounting, the instructions for which will be given in a subsequent page.

*On Mounting Microscopic Objects in Canada Balsam.*—We are indebted to Mr. Pritchard for the suggestion of this superb mode of embalming. In the 'Microscopic Cabinet' is given the first account of mounting objects in fluid, which afterwards hardened and rendered them permanent. This fluid is a thick solution of gum arabic, which when indurated is found to be very durable if kept in a dry place, but with damp is liable to mildew. This contrivance led to the employment of other media that should be free from this defect. Varnishes, such as the mastic, copal, &c., were severally tried, and each was found to possess some advantages; but the substance which is found to surpass all others is Canada balsam. Its merits are, that when once hard the preparation is permanent; is not affected by damp; the slide can be readily cleansed without injury; it remains clear and transparent; and, lastly, its refractive power is so great that bodies mounted in it are rendered sufficiently pervious to light to show their internal structure, which without it are too opaque to transmit a single ray.

So numerous are the objects that derive additional

interest by mounting in Canada balsam, that it would be occupying too much space to enumerate them here; it affords also the best material for cementing sections of shells, fossils, &c., to glass slides.

The method of applying the Canada balsam is as follows:—Warm the glass slips, &c. to a temperature just below the boiling heat of water. If there is any doubt of the balsam penetrating all the interstices and readily adhering to the specimens, it will be well to pour a few drops of clear turpentine upon the specimens, which will greatly facilitate the taking of the balsam; the latter, however, must not be used until the turpentine has nearly evaporated. The moment when the balsam is to be added with the best effect can only be known by experience. Clear old Canada balsam is the best suited for these purposes. When used it must also be heated to a temperature just below boiling water, and then poured upon the object, previously arranged upon a slip of glass. The top slip of glass, which is usually smaller and thinner than the under one, is now to be placed upon it; one end of each slip being brought into contact first, and then the other allowed to fall upon it. By this means no air-bubbles will be inclosed. The exact quantity of balsam required must be learned by practice. Of two faults, namely, too much or too little, the former is to be preferred.

*Note.*—Be careful not to press the glasses together hard, otherwise, on the removal of the pressure, the air will enter between the glasses and the preparation will be spoilt.

Having thus mounted your object, it must be slowly dried in a warm situation. This will take one or two days ; after which the slide is to be cleaned by scraping off the surplus balsam with a strip of plate brass (iron is liable to scratch the glass, and therefore is objectionable). Finally, wipe it clean, using first a linen rag moistened with turpentine, and then a piece of dry clean leather.

*On Preparing Woods for making thin sections.*—This process will vary with different kinds of wood. When the specimens are hard woods, which usually contain gums, resins, &c., the first operation will be to immerse the specimen in some essential oil, and keep it in a closed vessel at a moderate heat for a few days. This is necessary for the purpose of slowly dissolving out the resins, &c. ; otherwise a clean section cannot be made. Various solvents must be tried, such as oil of turpentine, oil of lavender, spirits of wine, sulphuric ether, &c. When the wood has been freed from resin and gum, it will be ready to be cut into thin sections. Specimens thus prepared should be kept in closed bottles with alcohol.

In soft woods the chief difficulty to be overcome in the preparation is in the drying. This must be slowly and uniformly done. The heat must never exceed the temperature of boiling water. The specimens when quite dry are ready to be cut. It is usual to cut soft woods dry, but some artists prefer immersing them in spirits.

In the preparation of woods great care must be taken not to rupture the different vessels or break the fibres

during the process. The specimens should be small; half-inch cubes are quite large enough. The top and bottom should be carefully cut at right angles to the direction of the woody fibres, and in exogenous woods the sides must be parallel and perpendicular to the medullary rays. When small branches or twigs are to be cut, it is only necessary to select a part clear of knots and cut the top and bottom horizontal.

*On Preparing the Vascular Tissue of Plants.*—The spiral, dotted and reticulated vessels of plants, require in most cases to be dissected out, which is to be done under a shallow magnifier. A single lens of one inch or one inch and a half focus will answer very well for this purpose. Having procured a piece of asparagus, the petiole of the garden rhubarb, or such other plant as it may be desirable to dissect, cut out a piece about one inch long, split it open with a sharp knife or scalpel, then examine it under the magnifier, and separate with a needle-point any of the vessels you require from the surrounding cellular tissue in which they are imbedded. This process is facilitated by dropping a little water on the specimen; and to prevent the specimen moving while dissecting, it should be fixed by bees' wax. Vessels, ducts, and cellular tissues, when prepared, should be kept in spirits of wine until mounted.

*On Preparing thin sections of Siliceous Fossils.*—For this purpose it is necessary to provide yourself with a thin soft iron circular plate. The best size for amateurs is five or six inches in diameter. Lapidaries usually



employ one about fifteen inches in diameter. This plate or wheel must be attached to an axis, and made to revolve rapidly. When ready for use about half an inch around the circumference on both sides is to be *paved* with diamond powder. This is done by rubbing the diamond powder, previously mixed in olive oil, on to the plate with a hardened steel roller. The wheel is now ready for use, and the fossil is to be held firmly against its edge while the wheel is rapidly revolving. In this way a thin slice is cut off the fossil. This slice is then to be cemented to a convenient block of metal, and the other side ground upon a flat metal tool with emery-powder and water. When this process is completed, the surface must be smoothed by grinding on another flat tool of slate, after which it is to be polished. The process of polishing may be performed in various ways. The best is to procure two discs of plate glass about five inches diameter; warm one of the plates, and pour upon it (as evenly as possible) a thin layer of pitch. When this is cool, take some opticians' putty-powder (oxide of tin and lead), mix it in a phial with cold spring water, and pour a little over the pitch; then rub the other plate of glass upon it, so as to render the surface of the pitch perfectly flat, without however allowing the upper plate of glass to adhere to the pitch. If the surface of the pitch cannot be readily made flat, the upper plate must be left on and pressed down by a heavy weight.

When the polisher is prepared, the fossil is to be lightly rubbed upon the pitch, using the putty-powder

and water freely until the surface has received a good polish.

In grinding, smoothing, and polishing, the directions in which the fossils are to be rubbed must be varied continually, so that the tool be worn uniformly and not become either hollow or convex.

The process of grinding, smoothing and polishing will be greatly facilitated, and the labour reduced considerably, if the tools are made to revolve during the working.

*On Preparing thin sections of Teeth, Bone, and similar Substances.*—These materials should be cut into very thin slices with fine saws made for the purpose of pieces of watch-spring, &c. They are then to be ground upon a hone, or water-of-ayre stone, with water, when they will be ready for mounting.

*To Prepare thin sections of Coal.*—These are cut with a saw, and afterwards ground on a fine sand-stone with water.

*To Prepare Skins of the Larvæ of Insects.*—Some require to be immersed quickly in boiling water, then taken out and plunged into strong acetic acid for a few minutes; others only require to be soaked in cold water; and some kinds require no such preparatory process. Make an incision along the back, beginning at the tail and passing the point of the scissors along towards the head. When laid open the inside must be washed out; and if the subject is a terrestrial larva, the trachea must be separated at each of the several spiraculæ, along each

side of the body, by means of fine scissors. When the skin is cleaned, it must be laid out on a glass slider under water; another slider must be covered over it, and the two bound together while the skin is dry—when it is ready for mounting.

*To Prepare the Respiratory, Digestive, and other internal Organs of Insects.*—These subjects must be opened by fine scissors along the dorsal surface, and the various organs to be dissected out must be operated upon under water. A glass slide is then gently introduced into the vessel, and the organ, being floated upon it, is to be arranged thereon in such a manner that when dry and mounted its form and structure can be readily viewed by the microscope.—*Note.*—Delicate objects of this kind must be slowly dried without a glass slide over them.

*To Prepare Butterflies, other Insects, Spiders, &c. entire.*—When these are large they require the exercise of much patience. Take out the inside as carefully as possible, by making an opening near the tail; lay out the specimen on a glass slide, (two inches wide by three inches long is the most convenient for butterflies); extend the wings, legs, and antennæ, and keep them in a proper position by affixing them with a little gum-water, if necessary, or, what is better, pour a little turpentine over the whole; cover them with another glass slider, and bind them together until flattened and dry—when they are ready for mounting.

*To Prepare the Shells of Fossil Infusoria.*—These usually consist of silica, and are mostly found mixed with

chalk, and more rarely with animal matter. When the shells are mixed with chalk, the latter must be separated by dissolving in dilute hydrochloric acid. A mixture of one part acid to from six to ten parts water should be made in a test-tube, and a little of the powder put into it and well shaken. It should then be left until the following day, when the dilute acid is to be poured off, and the shells at the bottom examined. If the chalk is not sufficiently dissolved, the process must be repeated until the whole has been removed, when the siliceous shells must be washed in pure water. They are then ready to place upon a glass slide for mounting. When in search of siliceous bodies among animal matter, as in guano, the substance must be digested in nitric acid, and subsequently washed in clean water.

*To Prepare Crystals for Polarizing Microscope.*— Pour a few drops of a saturated solution of the salt to be mounted on a glass slide; then gently warm it over a spirit-lamp, so as to evaporate the excess of fluid. In this operation care must be taken not to apply too much heat, as in that case the salt will lose its water of crystallization and become opaque. When the crystals are formed, examine under the polarizing microscope, and if perfect they are ready for mounting.

*On Mounting Ferns, to exhibit their Fructification.*— The genera are mainly distinguished by the position and arrangement of the organs of reproduction. These are mostly on the under side or along the margin of the leaf or frond. They are best examined as opaque objects,

and small pieces of the frond should be fixed by gum or Canada balsam to black discs about half an inch in diameter. It is important to select these specimens at a proper stage of their growth: if the reproductive organs are too young, they will not be sufficiently developed, while if ripe they soon become brittle; the elastic ring or case containing the spores break and scatter them; nothing is then left but the remains of the ring or case.

## CHAPTER VII.

### ON MOUNTING MICROSCOPIC OBJECTS.

(1.) *Transparent or Diaphanous Objects*—are usually mounted on slips of glass cut of a uniform size. The dimensions of these slides as proposed in the 'List of 2000 Microscopic Objects' were, No. 1 size, 3 inches long by  $\frac{7}{8}$  of an inch wide; No. 2 size, 2 inches long and  $\frac{5}{8}$  wide; No. 3,  $1\frac{1}{2}$  inch long by  $\frac{1}{4}$  of an inch wide. The latter size is seldom used except for opaque bodies, as hereinafter mentioned. The reason assigned by Mr. Pritchard for selecting these lengths was that they are multipliers of each other, and therefore the drawers or boxes containing them can be made of uniform sizes. The Microscopic Society of London has adopted the length of the first as the standard—that is, 3 inches. This size, therefore, it will be well to retain except where economy of money or space is of consequence. The No. 2 slides are sometimes preferred as containing less than one-half the glass and occupying a like reduced proportion of space.

(2.) *On Cutting Glass for Slides*.—The chief desiderata are clearness, freedom from veins, and perfect uniformity in length and breadth, whatever dimensions may be selected. The latter is best effected by having a cutting-board and

rule made as follows. Select a piece of well-seasoned mahogany or other suitable wood having its surfaces planed smooth and flat; let it be about 15 inches long by 10 inches wide. Along one side attach a raised edge, to project about  $\frac{3}{8}$ ths above the general level. Having determined the length and width of the glass-slides you intend to adopt, procure a cutting-diamond, the best form of mounting for which is the *Patent Plough*. This done, provide yourself with two rules about 12 inches long and  $\frac{1}{8}$ th of an inch thick; the one for cutting the glass of the proper length, and the other for the breadth of the slide. Ascertain the breadth of the steel mounting of your cutting-diamond, which is usually  $\frac{1}{10}$ th of an inch, and let the width of each rule be half that quantity less than the measure required. Thus for cutting slides 3 inches long and 1 inch wide, the rules should be  $2\frac{1}{2}\frac{0}{0}$ ths long and  $\frac{1}{2}\frac{0}{0}$ ths wide. To use this board, having cut one side of your plate of glass straight, place it on the board with its straight side close to the raised edge, then take the broad rule which determines the length of your slides and place it upon the glass likewise close to the raised edge. Draw the diamond across the glass, holding the handle between the two fore-fingers in an inclined position, and make the cut. The amount of pressure upon the diamond, and the inclination, are best determined by practice. Cutting-diamonds require to be of different sizes according to the thickness of the glass to be cut. The ordinary glazier's diamond is suited for window-glass, but for thick plate-



glass a larger diamond is necessary, while for very thin glass Mr. Pritchard recommends a writing-diamond with a well-turned point.

(3.) *To select Glass for Slides.*—If you determine to employ plate-glass, the principal point to be considered is the colour and surface. The former should be of a light blue tint, and the latter free from holes and flares: its thickness not more than  $\frac{1}{8}$ th of an inch. Window or table sheet-glass is, however, the most generally used, and requires to be free from veins and minute bubbles. The colour is best observed by looking along the edge of pieces several inches wide.

(4.) *On Edging Glass Slides.*—The edges when cut by the diamond are rough, and unless intended to be covered with paper should be ground smooth. This may be effected by rubbing them on a flat cast-iron plate with emery and water. It is well, for this purpose, to have three of these flat plates, or tools as they are technically termed. They should be about 7 inches in diameter and  $\frac{1}{2}$  an inch thick. These tools are sometimes made of bell-metal, brass or pewter: but for common use cast-iron will answer the purpose; it is less costly, and any number may be readily cast from one wood pattern. By having three flat tools, and occasionally grinding one alternately against the other two, and these two against each other, all errors in their surface may be destroyed. Thus, if two tools both hollow in the centre be ground together, they will be brought flatter, and thus by grinding them with the third tool other errors are corrected. When the



tools are ready, a number of glass slides may be bound together and ground on the tool with water and emery. The chief care required is to grind uniformly on every part of the surface of the tool.

In some cases it is desirable to bevel the edges of the slides. When this is required, it is necessary to attach them to a block of wood, one side of which is bevelled to the required angle.

(5.) *Polishing Slides.*—When this is required, the polishing may be effected by rubbing them on a flat tool covered with either leather or silk. The surface of the material on which the glass is to be polished must be impregnated with putty-powder (oxide of tin and lead) or the red oxide of iron. Either of these is used, like the emery, with water. It is necessary to remark, that prior to the polishing the edges must be made perfectly smooth by grinding with fine emery-powder.

(6.) *Mounting Transparent Objects between Glass Slides of equal thickness.*—An elegant method of mounting transparent objects which do not require an object-glass of short focus for their examination—as sections of recent woods, entire mosses, &c.—is to place them between two bevelled edge slides of equal size, as shown in the figure.



In this case the edges should be left rough from the grain emery, as they thus take better hold of the cement or sealing-wax with which the groove formed by the

union of the two slides is filled. The best plan to mount an object in this way is as follows. Having procured a number of bevelled edge slides of like dimensions, take some small pieces of red sealing-wax and dissolve them in alcohol, or spirits of wine, using a little heat to facilitate the solution. This solution should be kept in a well-stopped bottle. Now take the glass slides, and, having cleansed them from grease and dirt, cover the edges with this solution, which may be readily done with a camel's hair pencil. The slides should be immediately placed on a warm plate to evaporate the spirit quickly. When thus prepared the slides are ready to receive the objects. Place the objects on the slide in the position you wish, and to prevent it from shifting when covered by the top slide, take a very small quantity of gum-water, and just touch the corner of the object to attach it to the lower plate of glass. In like manner a label with the name of the object may be placed at the end. It may be remarked that the less gum or other matter used to fix the object in its place the better. Now take the upper plate of glass and cover it over the object. One end of the slide thus formed is to be held between the fingers, while the other is heated with a spirit-lamp, and the groove filled with a little sealing-wax, as shown in the engraving at *a*; then reverse the ends and repeat the process. The slide is now fixed, and the groove along its sides can then be more conveniently filled with the cement. When this is finished, it is necessary to clean off any redundant wax. For this purpose lay a sheet of glass or scouring-paper on

a flat board, and rub the edges until quite smooth. If a bright edge is preferred, it may now be instantly passed through the flame of the spirit-lamp.

Slides made in the manner above described are very durable, and the preparation will not be liable to injury from damp. We have now under inspection a collection of several hundred slides of recent woods, British mosses, crystals for polarization, &c. &c. mounted in this way, which after the lapse of fifteen years are as perfect as on the day they were put up.

(7.) *Second Method of Preparing Glass Slides for Sealing.*—This plan has some advantages over the first, as it enables you to employ very thin plates for covering the object; but it is more liable to injury. The lower plate should be of thin *plate* glass about  $\frac{1}{10}$ th of an inch thick, the edges carefully squared; the upper plate may be as thin as required; it must be cut about  $\frac{1}{8}$ th of an inch shorter and narrower than the lower one. After the object has been arranged upon the lower plate, the upper one is to be placed over it in such a manner as to leave a uniform margin around the lower plate. By this means a rectangular groove is formed, which is to be filled with sealing-wax. As the upper plate is usually thin, the best and strongest cement for this purpose is japanner's gold size thickened with a little vermilion, or when that colour is not desirable, lamp-black.—*Note.*—When the objects are mounted in a fluid or spirits, vermilion is objectionable, the mercury being liable to chemical change.

(8.) *Mounting Crystals for Polarizing Microscope.*—

These must be so inclosed that the air is completely excluded from them ; otherwise a change will soon take place, and the objects be spoilt. They will keep unchanged in the mounting (§ 6) for many years. When it can conveniently be done, it is as well to mount them in Canada balsam, which renders them less liable to injury from exposure to the air than any other plan, and reduces the refraction at the edges. Sir David Brewster recommends mixing cold-drawn castor oil with the Canada balsam. In this case the edges of the slide must be cemented, as the oil prevents the balsam becoming hard.

(9.) *Writing-Diamonds.*—Every slide containing an object should have its name legibly written upon it. When the mounting is entirely of glass, this must be written upon it with a diamond. Writing-diamonds are of two kinds; namely, a splinter—that is, a diamond broken into pointed pieces—and the second a turned point: the latter is the most preferable, but is more expensive, the diamond requiring much time and labour to be turned conical.

(10.) *Papering Slides.*—By far the greater number of slides containing microscopic objects require to be covered with paper, to give a neatness and uniformity of appearance to them. The best plan for this purpose is, first, to cover the edges with a slip of very thin paper pasted over them ; secondly, take a piece of dark-coloured paper cut rather smaller than the slide, and having a hole punched in the middle to allow the object to be seen through it, and paste it on the under side of the slider ; (always select the thickest glass for the under slide ;)

thirdly, cover the top with a similar paper, but of a different colour ; and lastly, paste on a label with the name of your object. A neat and excellent cover for the upper side of your slide is the engine-turned pattern given at the end of this little book. It is a purple paper printed with a gold pattern. The centre is to be punched out for the object, and the square blank near one end is to be cut out to receive the name. For this purpose a white paper label had better be pasted on the slide before the cover. These plates, each having six labels, may be purchased by the dozen or hundred as may be most convenient.



(11.) *Mounting Opaque Objects.*—The above engravings represent three methods of mounting microscopic objects to be viewed by reflected light. The first figure on the right hand represents a disc of leather, felt, or other suitable material, about  $\frac{3}{8}$  or  $\frac{1}{2}$  an inch in diameter, with a pin passing through it as seen in the drawing. The side for holding the object is to be blackened; the other side is covered with white paper on which the name is to be written. The middle figure represents another plan

for very minute objects, which is preferred by some microscopists: here the pin is encased with blackened wax or cement, or it may consist of small cork cylinders. The third plan of mounting shown in the drawing consists of cylinders of cork or felt. They are punched out of a piece of either of those materials, whose thickness is equal to the length of the required cylinder, and having a common pin passed through them. They must be blackened with common lacquer and lamp-black, holding them over a candle to dry. Sometimes these cylinders are made of ivory: in such case the inside should be turned hollow like a small box, and the pin, as before, running through the middle, is to be the support of the object instead of the surface, as in the cork cylinders. The ivory is then to be dyed black, and the inner surface made as sombre as possible. This plan enables the observer to see the delicate structure of an object more distinctly; indeed it is the only method by which we can develop the structure of some objects by reflected light, such as the minute sponge-like glands over the foot of the common fly. Remember, that the darker the object the more black and sombre must be the mounting. In such cases the reflected rays of light from the object are so few that reflections from other bodies would entirely drown them. This it is necessary to mention, as some persons have thoughtlessly mounted their objects on the white ivory. The glare and fog produced by this mistake are sufficient to injure the vision of the most perfect instrument.

The best cement for fixing objects on these mountings is mastic varnish. These mountings are held in the forceps by the pin; if the forceps are large, they should have a hole made through their sides, to secure the head of the pin, which is otherwise liable to slip out: it also enables us to turn the object about the head as a centre without any risk of its escaping; see *s.* in fig. 23 of 'Microscopic Illustrations.' The cylinders may be made of various sizes and arranged in cabinets, the bottom of the drawers being covered with cork about a quarter of an inch thick, into which the pins are inserted. The blank end of the cylinder should have a number painted in white, corresponding with another in the list of the names. When arranged in the drawer all the pins should be slightly inclined in one direction with their numbered ends upwards, which enables you readily to take out any object by referring to the list, and also protects the objects from dust falling upon them. A vast number of objects by proper arrangement will thus occupy very little space.

(12.) *On Preparing very Diaphanous Bodies.*—In all cases it is desirable to mount an object permanently; but it sometimes happens that while we effect this purpose, the object becomes obliterated and lost to vision. This occurs when mounting an object in a fluid, as for example Canada balsam: if it is of the same colour and refractive power as the balsam, the rays of light will not be bent in passing in and out from the one to the other. When this is likely to happen, the object must be slightly

charred or dyed in a decoction of fustic or other dye-wood, and when of a sufficient colour it is ready for mounting. The vascular and cellular tissues of delicate plants, the scales of fish, &c., are often improved by colouring.—*Note*.—Objects for the polarizing microscope do not require colour, as the light is decomposed and not simply refracted by them.

In preparing and mounting microscopic objects the following articles will be useful:—

Glass slides.—No. 1, 3 inches by 1; No. 2, 2 inches by  $\frac{5}{8}$  of an inch. Thin glass, in slips and circles; thickness about 1-30th of an inch. Black, white, and coloured papers.

Watch-glasses,  $1\frac{1}{2}$  to 2 inches diameter.

Small white painters' saucers, 2 to 3 inches diameter.

Turpentine, and spirits of wine.

Canada balsam (old and clear).

Gum-water.

Hydrochloric and nitric acids.

Japanners' gold size and Brunswick black.

Glass tubes, various sizes from 1-20th to  $\frac{1}{2}$  an inch diameter.

Needles in handles.

Fine wire gauze for sieves (various sizes).

Camels' hair brushes.

Cork for cutting out discs, &c.

Pigs of dog-wood as used by watchmakers.

Writing-diamonds and plough cutting-diamonds.

Pointed scissors, two or three sizes.

Clean chamois leather.

Elder-pith, dry, to clean hard bodies.

Scalpels or fine knives.

Card-boxes 3 inches long by 2 inches wide, clean inside.

Pliers, tweezers, nippers and small files.

A spirit-lamp.

Punches, various sizes.



## CHAPTER VIII.

### MICROSCOPICAL FRAGMENTS.\*

#### (1.) *On Stopping False Light in Microscopes and Engiscopes.*

—This is one of the most important requisites in an instrument; for however perfect it may be, if there is the least light reflected from the mountings of the glasses, or within the tubes, the fog and glare produced will materially deteriorate their performance; it is therefore absolutely necessary that all their surfaces be made as sombre as possible. The usual method of effecting this is to cover the parts while hot with a black lacker, made by mixing lamp-black in a solution of shell-lac in strong spirits of wine. A more elegant method, and better suited for delicate work, is to wash the surface, previously freed from grease and tarnish, with a solution of platina in nitro-muriatic acid (chloride of platina); after remaining on the work a few minutes it is wiped off, the surface having assumed a deep brown or black colour. If these are not at hand, a strong solution of muriate of ammonia

\* Extracted from Mr. Pritchard's *Microscopic Cabinet*.

will answer for temporary purposes; but I have never found anything equal to bronzing the surface by the solution of platina. Another method of stifling false light is by stops; these are very useful in the body of a compound microscope. These stops are diaphragms made of plates of metal or wood, having a hole in their centre, and then blackened. Persons should be on their guard in examining an instrument having these stops; for they are often put in to cut off the aperture of the object-glass, and thereby deceive the inexperienced, who seeing the size of the object-glass imagine the whole is used, whereas the most important portion is not employed. This is a very common case, and ought to be exposed. Diaphragms under the stage improve the definition of a microscope, but reduce the angular aperture, and consequently the penetration; they are nevertheless very useful and necessary for some objects, especially where currents or things in motion are to be examined.

(2.) *Mounting Transparent Objects.*—The most usual method of preserving these objects in a dried state is between plates of talc or mica fitted into cells formed in ivory sliders, having a split ring of wire to secure them. The bottom of these cells should be turned quite flat, to afford a good bearing for the mica, and of sufficient thinness to permit the magnifiers to approach the object. In using these slides, it must be observed that there is a wrong and a right side, or the student will not be able to approach close enough to the object with the high powers. The ring side should

always be placed downwards, or from the microscope, and the other side next the eye or instrument. The softness of mica prevents it being cleaned like glass; it should therefore be kept as free from dust as possible, and only brushed lightly with a camel's hair pencil when necessary, and never touched by the fingers. When test-objects are to be mounted in this way, only one or two cells should be mounted in each slider, which will lessen their liability to injury.

(3.) *Method of Mounting very minute Transparent Objects in Brass Sliders.*—A simple and convenient method of preserving such objects (contrived by Dr. Goring) is between plates of talc within a folded piece of very thin plate-brass, as shown in the annexed figure.



These sliders are so easily formed that any person with a penknife and scissors can make them. Procure a piece of latin brass about the thickness of banknote-paper, and cut off a slip the length of the intended slider, and twice its breadth; then fold it down the middle and make a small hole for the object (see the figure): now take a piece of talc a little narrower than the brass and make a slit with the penknife down the middle, leaving a portion uncut at each end, so as not to separate it; then put in your object, and fold it as you did the brass; lastly, insert the talc thus folded between the sides of the brass, and pinch the edges of the latter close, and the slider is

completed.\* As their size need not exceed that of the diagram, several of these sliders with test-objects may be carried in a pocket-book, and are always ready to examine the merits of any instrument that may present itself.

(4.) *On Mounting Transparent Aquatic Objects and Dissections.*—Many small subjects of natural history are so delicate that when dried their parts are shrivelled so much that it is with difficulty their features are recognised. It therefore becomes important to discover some method to preserve as much as possible their beauty, colouring and lineament. This is best accomplished by placing the object on a slip of glass, and covering it with a piece of thin glass, interposing a drop of a thick solution of gum or isinglass; by this means the object is prevented from drying, and when the gum has hardened, is effectually preserved. In this way may be mounted all the aquatic objects described in this work,† many of which cannot be preserved in any other way; they are the nearest approach to living subjects I have seen. These sliders should have a piece of paper pasted over the thin glass to protect it from injury, leaving an aperture in the centre for the object and made of an uniform size. This method of mounting objects led to the subsequent improved one of Canada balsam; indeed the substitution of balsam

\* If thought necessary, the edges may be cemented; if the hole is small, it acts as a stop or diaphragm, and a known object is also thus more easily found.

† See *Notes on Natural History*.

or varnish for the gum or isinglass would readily suggest itself to any practical chemist engaged in these matters.

(5.) *On Preserving Objects in Fluids.*—Take a slip of glass and spread a little white lead ground in oil on the upper side, leaving an aperture in the middle to receive the object. This paint being laid on of the thickness of the object, the little pool or cavity is filled with weak spirits of wine; then lay in your object. Having procured a piece of thin glass of the proper size, lay it on the top, and with a stick of wood rub it close down on the paint, beginning at one end and passing across the slider to the other, so as to exclude all air bubbles. In this way the delicate vessels of plants, &c. may be preserved. I have mounted animalcules and small crustacea in this way with complete effect. Active molecules may be kept thus mounted for months. Other fluids, such as solution of common salt or corrosive sublimate, might in some cases be preferable to spirits.

(6.) When the objects are large and do not require a very high power, they may be cemented on the slip of glass itself with a piece of black paper under them, or a wafer may be fastened to the under side of the glass, to give a back ground when viewed as opaque objects, and removed when examined by transmitted light; or a black cylinder of cork may be held under a transparent object to view it by reflected light. The mode of mounting large objects on slips of glass with paper under them is here shown. These sliders should

be arranged in shallow drawers, like transparent objects, as hereinafter mentioned. When the objects are very



minute, and the magnifying powers high, the objects may be mounted on the heads of common pins; but remember that this method should not be adopted when the aperture of the magnifier is larger than the head of the pin, as the direct light from the condenser would be admitted and produce glare.

(7.) *Method of viewing the Internal Organization of Animalcules.*—The usual food of these animals assimilates so closely in colour to themselves, that it is impossible under ordinary circumstances to perceive the form of their digestive functions. During the investigation of the polype by Mr. Trembley, he endeavoured to ascertain whether the small granular bodies dispersed over its surface were digestive cavities, and for this purpose fed these creatures on organic coloured substances, such as indigo. This idea has been recently followed up by Dr. Ehrenberg of Berlin, who has successfully employed minutely-divided coloured substances, such as indigo, carmine, and sap green, for ascertaining the form of the digestive cavities in animalcules. It is essential that whatever the colouring-matter we employ be, it must be pure and free from any metallic impurities, and that it be only mechanically, not chemically soluble in water. For more minute directions on this subject see ‘General History of Animalcules.’

(8.) *On Exhibiting Animalcules.*—These creatures, found so abundant in stagnant waters containing infusions of organized matter, afford considerable amusement and instruction in the inspecting of their habits, &c. They usually congregate around the edges of the vessel and on the surface of the fluid. The best method of placing them under the microscope is by means of the *feeding-pin* represented in the annexed engraving. It con-



*Feeding Pin.*

sists of a glass thread inserted into a convenient handle, the end of the glass being enlarged like the head of a common pin, which is to be dipped into the infusion. In this way a small drop of the fluid containing them may be placed on a slip of glass and covered with another thin slip to prevent evaporation and keep the surface of the fluid flat, or put into an aquatic box for examination. When it is desirable to examine the contents of different

infusions, the feeding-pin should be washed in distilled water between each dip, to prevent any mixing. This little contrivance will be found more effective and useful than the point of a quill or a camel's hair brush.

(9.) A very amusing exhibition of animalcules is made in the following manner. It is especially calculated for the solar or gas microscope, or indeed any other where the objects themselves are not under immediate inspection. The main feature is the apparent control of the exhibitor over the actions of these minute beings, and their obeying his commands. Procure a water-trough, similar to the one here represented, composed of two

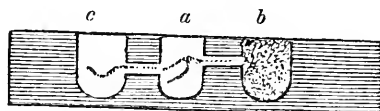

slips of glass cemented on each side of a plate of metal of the proper thickness, and of the form shown in the figure, the light part being that which is removed. If it is now filled with clean water and the middle cell, *a*, placed before the microscope, and a drop of the infusion containing the animalcules put into the cell *b*, on command of the exhibitor the animalcules will commence marching across the field of view, and to those unacquainted with the plan it will appear in obedience to the order, but is in reality merely for the purpose of spreading themselves. In the same manner when the cell *a* is full, *c* may be put under the instrument, and the marching again commences, the little animals not being able to pass from one cell to the other singly.



(10.) *Method of selecting Aquatic Larvæ, and other small Animals.*—The animals described in several of the preceding chapters\* are large and visible to the eye. These require to be kept in vessels of considerable dimensions, which renders it difficult to select any particular specimen, as is also the case with the more minute ones in phials. For effecting this purpose Ledermuller has described and figured in plate 87 of his work a very ingenious contrivance; it is simply a glass tube open at both ends, and is employed in the following manner:—Hold the tube by the upper end between the fingers, and close the orifice by the thumb (see the annexed figure); then

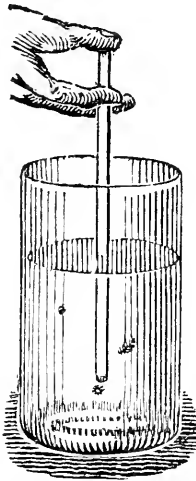

immerse the lower end in the vessel of water, and the instant the insect desired approaches the end of the tube, remove the thumb from the upper end, and the pressure

\* See *Notes on Natural History.*

of the atmosphere will force the water with the insect up the tube, when the thumb is again to close the upper aperture, and the tube with the object is to be removed. These tubes may be of different diameters to suit the various objects.

(11.) *Net Spoon*.—Some of the larvæ of insects are very delicate, and require very gentle means for removing them into aquatic sliders or boxes for examination. This may be very carefully done with the net-spoon here figured. It consists of a wire bent in the form shown and covered by a piece of muslin or net.



(12.) *Aquatic Sliders for Live Objects*.—These are made in various ways. The best for large objects is the water-trough represented in the next figure; it is composed of two plates of glass, having a plate of metal or a lump of sealing-wax between them, leaving a space in the middle for the object and water. They may be executed of various lengths and thicknesses, and have their sides parallel or angular; the latter is sometimes useful, as they confine the insects at the bottom, and are thus prevented from going out of the field of view. For the solar microscope this method of displaying them is preferable to the aquatic live-boxes, and when of sufficient size, under low powers a branch of moss may be inserted, which will produce an interesting spectacle, among a group of different insects, who will exhibit a

variety of diverting pranks and tricks ; some engaged in a fierce and obstinate combat ; others darting between the branches in search of prey ; and others cautiously avoiding the more predacious ones.



(13.) Another plan is to confine the insects as shown in the following figure, which represents a plate of glass covered by one of metal of suitable thickness cemented to it, and having an aperture in the latter to receive the insect, which is covered by a plate of thin glass. This plan is valuable for viewing the circulation in plants under a *vertical* microscope.

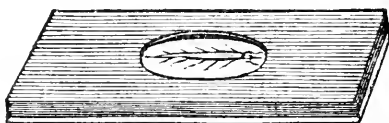

(14.) *Aquatic Live Boxes*.—The most useful of all these contrivances is the aquatic box represented in figure 21 of the ‘Microscopic Illustrations.’ It consists of a short piece of tube, the lower end of which is fitted to the stage of the microscope, or fits into the slider-holder, having a circular piece of glass fixed to its upper end ; over this fits another piece of tube forming the cover, with a circular plate of thin glass fixed to it, the objects being situated between the box and the cover. They may be made of various sizes, and by sliding the cover more or less on the box, the distance is varied to

suit the thickness of any object. When required for high power the cover should have a very thin plate of glass to permit the magnifier to approach closer to the object. In the larger boxes a small hole is made in the side of the cover for the escape of air and superfluous water, which is afterwards closed with bee's wax.

To render these aquatic boxes more useful the bottom glass should have a series of lines cut on its superior surface for measuring the size of the object, which in this manner is done without any additional trouble, and renders them a valuable addition to a microscope, serving the purpose both of a micrometer and object-holder. The divisions most useful are the one hundred in an inch. In using these micrometers the observer will do well to rub into the lines a little black lead, by taking a pencil and rubbing the point obliquely across them.

Observers often find it a difficulty to ascertain which side of the glass has the lines engraved on it: but although the eye cannot detect them easily, they may always be ascertained readily by rubbing the finger-nail across them.

The most complete live-boxes for animalcules are those having a small disc of glass cemented to the lower glass. This disc may be divided into micrometer squares if desirable. The chief use of the disc is to prevent the drop of water from spreading: thus infusorial animalcules cannot swim beyond the edge of the disc, and hence they can always be brought within the field of view of the microscope.

(16.) *Compressor, or Crush-box.*—This is a modification of the aquatic live-box. The cover or upper plate has either a screw cut within it or is jointed to an arm connected with a screw. The design of either contrivance is to enable the observer to bring the upper and lower plates of glass, between which the animalcules are placed, in contact, and thus crush them. It is only in this way that the existence of a lorica (shell) can be verified in some minute infusoria, as in the family Cryptomonadinæ. See ‘History of Infusoria,’ page 113, fig. 33.

*Note.*—In whatever way the compressor, or crush-box, is constructed, the upper glass must not, in its approach to the lower one, have a lateral motion, but only a vertical one.

(16.) *Arranging Transparent Microscopic Objects.*—One method for a small collection is to have a cabinet with shallow drawers (twelve of them occupy a depth of  $4\frac{1}{4}$  inches); the most convenient width from front to back being six inches. Into these shallow drawers the slides containing the objects are laid flat in double rows. The outer ends of the slides are made to fit into a ledge in the front and back of each drawer. The inner ends of the sliders meeting in the middle of the drawer are kept down by a very thin slip of wood covered with velvet. In this way the sliders do not shake when the cabinet is moved from place to place; every object is seen without removal, and thus no loss of time is occasioned in making a selection.

Whatever plan be adopted for arranging microscopic objects, it is always advisable to arrange them so that

they can be seen without removal, which cannot be done when lying upon their edges.

A convenient size for a fixed cabinet, where slips of wood and grooved edges are not required, is 12 inches long, 9 inches wide (from front to back), and  $\frac{1}{4}$  of an inch deep. These are the inside measures of each drawer, which will contain 36 slides of the standard size, namely 3 inches long by 1 inch wide, or 84 of the second size. A cabinet of 20 shallow drawers of these dimensions and four deep ones for opaque objects, will form an excellent museum capable of containing nearly 2000 illustrations of animal, vegetable and mineral specimens. Such a collection is now before us.

(17.) *Traversing Motion for Objects under the Microscope.*—It is often desirable to move the object across the field of view without altering the illumination, especially with very minute ones, and in the case of animalcules, Entomostracea, &c. When a motion is to be communicated to the objects, it is generally effected by two screws working in separate plates at right angles to each other. By this means a motion is obtained in any direction by turning first one and then the other, or the same is effected by two racks and pinions or by levers: the latter is the simplest, but unless properly constructed is very liable to become unsteady, and is often in the way, preventing a candle, &c. from approaching close behind the stage; the disadvantage of the other method is, that the observer is usually compelled to use both hands in this adjustment. The plan contrived by Mr. Pritchard is a single screw, which is made to act at the same instant

as a lever ; by this all the motions are obtained in a very simple manner, as shown in the annexed figure.

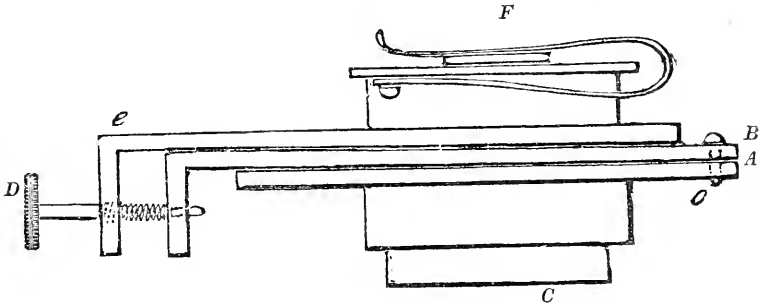

The end *C*, which is cylindrical, fits into the stage of the microscope, or the lower immovable plate *A* may be the stage. This plate *A* is fixed to the part *C*; it has a circular aperture in the middle, and a small hole at *o*, which acts as the centre of motion for the plate *B* to turn about ; on the top of this plate is another, *e*, which carries the slider-holder and object *F*. This plate is moveable to and fro by turning the screw by the milled head *D* ; and at the same time a cross motion may be communicated to the object by moving the head *D* laterally, which carries along with it the plate *B*, the centre of motion being *o*. The plates *A*, *B*, *e*, must be fastened together ; which, however, it is not necessary to show.

By this contrivance a traversing motion in any direction is obtained with the milled head *D*, by one hand only. No part of it is in the way of the illumination, nor is it liable to derangement.

In Mr. Pritchard's standard microscope, described in another part of this work, this method of obtaining a traversing motion is adopted with complete success.

(18.) *A New Pocket Microscope.*—“Portability is a quality so essential in the opinion of many persons, that I have been induced to construct a small instrument for their use, which at the same time should be more consistent in its principles than those in common use, and I believe will be found much more simple and equally useful. Similar instruments before the public, to render them portable, are separated into two or more pieces. This is obviated in my construction by the bar running within a tubular stem. Another objection in the common ones is, that in using high powers, the illumination is more feeble than with low powers; but it must be evident that the reverse ought to be obtained, for the more we amplify an object the darker it becomes. In their construction they remove the object further from the light, the higher the magnifying power; in mine, the magnifier is brought to the light, the object being stationary. The bar is triangular, and therefore less liable to shake and loosen than square ones. A rough sketch of the microscope with the triangular bar partly drawn out to show the rack, is here given. *a* are two magnifiers, of which there are four; they fit by a spring into the arm at the top of the bar; these magnifiers are adjusted to the object placed upon the stage *b* by the milled head *c* of the pinion, and the light is directed through it by the mirror *d*, which can be turned about in any direction and fits into the stand or block *e*. When the bar is lowered and the magnifiers taken out of the arm, the instrument, which is now only two metres and a quarter



long, fits into a case (about the size of a snuff-box) one inch and three quarters wide by one inch deep. The four magnifiers pack between the stage and the mirror,

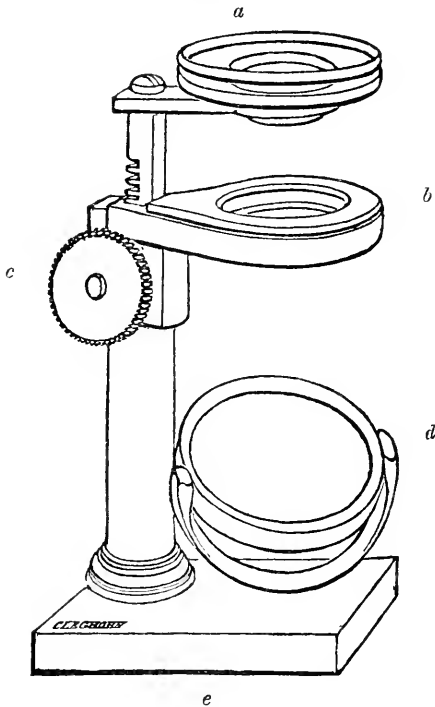

and do not occupy any extra space. If it were desirable, additional magnifiers might be added for viewing test-objects; a finer adjustment might also be applied, and Dr. Goring's illuminator or stops. A useful appendage is a large condenser placed before the reflector."

Since the above description was published in the 'Microscopic Cabinet,' achromatic lenses have become more plentiful and less costly. In all cases, therefore, where the sum of five or six pounds can be devoted to

the purchase of a microscope, the solid stage vertical achromatic microscope described at the end of this little book is preferable, being by far the cheapest and most useful construction to be obtained for so small a sum.

(19.) *Scissors for Dissecting Minute Objects*.—These are far preferable to knives or lancets, for the division of delicate bodies; the best mode of constructing them is shown in the annexed figure.

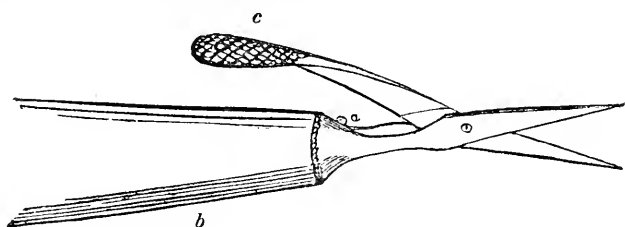

They are held by the handle *b*, which is fixed to one blade, so that the fore-finger is at liberty to press upon the prolongation *c* of the other to close them; they are always kept open and ready for cutting by a spring. It is stated of Swammerdam (who has surpassed all others in his dissections) by his biographer Boerhaave, “that the constructing of very fine scissors and giving them an extreme sharpness seems to have been his chief secret. These he made use of to cut very minute objects, because they dissected them equally; whereas knives and lancets, let them be ever so fine and sharp, are apt to disorder delicate substances, as in going through them they generally draw after them and displace some of the filaments.”

(20.) *The Microtome* is a pair of scissors somewhat

similar to those described above, but having an adjustment for limiting the opening and closing of the blades, which is effected by means of screws or slides. The scissors described above may readily have this adjustment by passing a loop of thin wire around the handle and arm near *c*.

(22.) *Eye-shades for looking through Microscopes.*—It is necessary when we examine with one eye an object through an instrument, not to permit any excitement on the other, and to shade it from surrounding lights. In compound microscopes this is easily done by a large disc of card-board, having a hole in its centre, placed over the eye end of the instrument; but the best plan for general purposes is to have a pair of spectacles with a thin black disc in one aperture, and the other empty, as here shown:—

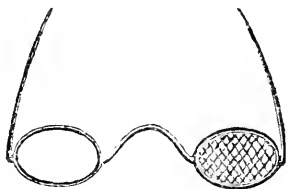

(23.) *Candlestick for Microscopic Purposes.*—It is very desirable with artificial light, to be able to turn it about in any position: this may be effected by employing a candle- or lamp-holder, similar to either of those shown in the engravings in page 172. The candle in either is capable of being raised or lowered as may be required, and that having the condenser serves also to illuminate opaque objects with a strong light.

It may be remarked that the various kinds of composition candles which consume their own snuff are very bad for microscopic purposes except the bat's-wing kind. In the other sorts the two wicks revolve, and thus present an unequal quantity of light in a given direction; sometimes the two wicks being presented edgewise to the object, at other times standing in a line.

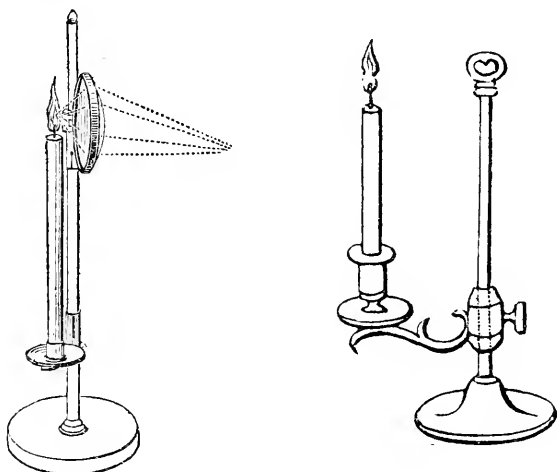

It is sometimes advisable to shade the light from the surrounding objects. In this case a copper tube with a small aperture in its side may be made to fit over the flame. We must now use the flame of a lamp, as a candle would melt in such a situation. If a candle be preferred, then a shade attached to an arm may be employed.

## CHAPTER IX.

### ACHROMATIC MICROSCOPES.

ONCE upon a time, at a meeting of a certain society of savans, a telescopic speculum 15 inches in diameter was submitted to their judgment. The surface of this speculum was most exquisitely polished, and as the fellows severally examined it they all praised its great beauty. At length a well-known practical astronomer was requested to give his opinion on this work of art, which he declined doing, stating as a reason that a speculum might have a very fine polish and yet be thoroughly useless if its figure was not accurate. This remark applies with equal force to the construction of the Microscope, which may exhibit great mechanical skill, exquisite workmanship, and a high degree of finish, and yet for actual use be a very inefficient instrument. In Chapter viii. of the 'Microscopic Illustrations' were given the first regular directions for the construction of Microscopes. The principles there laid down have been acknowledged more or less by all our first-rate makers since its publication, though each artist has varied some portion of the details to suit his own views. There is therefore some difficulty in selecting for the reader a form in real use possessing

every requirement, as the microscopes of one maker in some particulars surpass those of another, while again in other parts they fall short. Under these circumstances it has been deemed advisable to select two forms of microscope lately constructed by Mr. Pritchard, who having been the first to enter this field of inquiry, and to give the public the fruits of his experience in these matters, is entitled to precedence.

*Description of a new Vertical Achromatic Microscope.*  
—This instrument was constructed with a view to afford to naturalists and to medical and scientific men in general, as well as those persons who desire to view the curious and the beautiful in the minutiae of Nature's productions, a microscope at a moderate cost, and yet one whose performance might be relied upon. The modern microscope, with all its trappings, is an expensive affair, and requires some skill and practice to bring out all its merits. Naturalists and medical men have long felt the want of a simple microscope that shall faithfully depict the structure of bodies submitted to it, and which shall at the same time be compact in form and small in expense. These desiderata appear to be accomplished in the instrument represented in the opposite page, the price of which, including three pair of achromatic lenses and case, is 5*l.* 10*s.* Its optical qualities are clear definition, moderate penetration, and a large field of view. The mechanical advantages are great steadiness, a good adjustment, together with the utmost simplicity and portability consistent with fitness for general purposes.

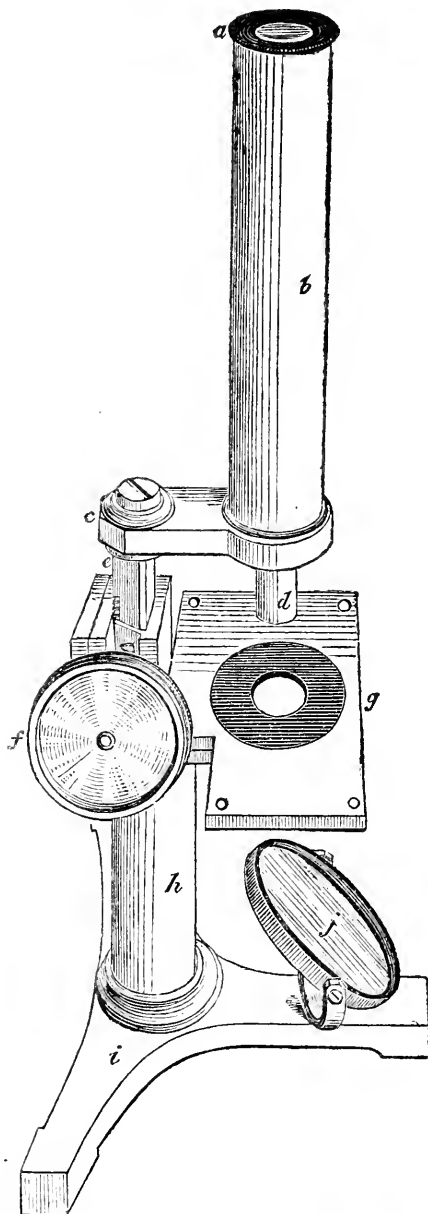

*Mr. Pritchard's Vertical Achromatic Microscope.*

*Description of Engraving.*—The eye-piece is seen at *a*, the body at *b*, and the object-glasses are screwed into the bottom of the tube or body at *d*. The arm *c* is attached to the top of the triangular gun-metal bar *e*, and has a motion round the latter. The large milled head, *f*, has a pinion which works into the teeth of the rack *e*, and serves to raise and lower the body, and thus adjust the distance to the focus of the lenses. *g* is the stage upon which the objects for examination are to be placed. This stage has four holes at its corners, which serve to hold a pair of forceps, or to pass a string through when viewing the circulation of the blood in a frog's foot, the frog being previously fastened to a piece of wood or lead in a cloth bag. In the centre of the stage is a black annulus, which can be removed when viewing opaque objects with a silver cup. *h* is the stem of the microscope, *i* the triangular pedestal, and *j* the mirror.

*Additions to this Instrument* relate chiefly to the optical part. They consist, first, of additional sets of object-

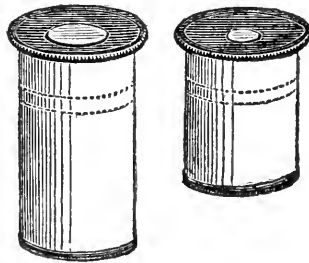

glasses and eye-pieces for giving a greater range of magnifying powers, as shown in the table given in page 179. The above engraving shows two eye-pieces, the



shorter one producing about double the power of the long eye-piece. (Remember, the shorter the eye-piece the higher the magnifying power.) Either eye-piece fits into the body of the microscope, *b* (p. 175).

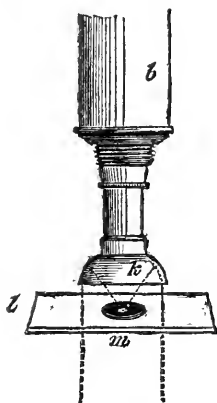

For viewing opaque objects a silver concave reflector, *k*, (usually called a cup, or Leiburkuhn,) is fitted over the object-glass, as seen in the annexed figure, *l* being the slider on which the object *m* is attached.

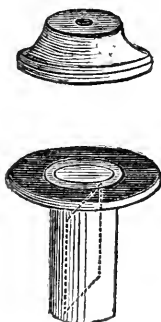

The most convenient form of polarizing apparatus adapted for this microscope is seen in the above engraving. The upper figure represents the analyser, which consists

of a plate of tourmaline fitted to a cap which covers over the eye-piece. The lower figure is the polarizer, which consists of a single-image prism: its mounting fits into the large aperture in the stage *g*. In using this apparatus first insert the polarizer in the stage, then place your object upon it, and direct a strong pencil of light through them; now adjust your microscope to distinct vision; and lastly, cover the eye-piece with the analyser. By turning the analyser until the whole of the light is stopped except that which is depolarized by the object, the crystals appear like gems upon black velvet: when this is effected, if the analyser be turned a quarter round, the crystals will assume complementary colours, and the ground will then be luminous. For viewing thin sections of the hoofs of animals, quills, bone, teeth, the palate of the whilk, &c., a thin plate of selenite should be placed under them.

In viewing transparent objects it is often desirable not to permit any light to fall upon the objects; otherwise a fog is produced. This may be prevented by fitting the shade (represented in the annexed engraving) upon the stage by means of its two pins.

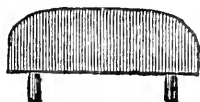

The following is a table of magnifying powers of Mr. Pritchard's Vertical Achromatic Microscope. They are calculated by a ten-inch standard of sight, and are given in diameters.—*Note.*—Those who wish to ascertain

the superficial magnifying powers may readily find them by multiplying either of the following numbers by itself.

| FOCUS OF OBJECT-GLASS                    | Long Eye-piece. | Additional Eye-pieces. |
|--|-----------------|------------------------|
| One-third of inch.                       |                 |                        |
| Posterior pair of lenses . . . . .       | 35              | 60                     |
| Posterior and middle pairs combined .    | 80              | 140                    |
| Three pairs of lenses combined . . . . . | 120             | 200                    |

ADDITIONAL OBJECT-GLASSES.

|                                    |     |      |
|------------------------------------|-----|------|
| One-seventh of an inch . . . . .   | 225 | 400  |
| One-tenth of an inch . . . . .     | 325 | 580  |
| One-twelfth of an inch . . . . .   | 450 | 800  |
| One-twentieth of an inch . . . . . | 800 | 1420 |

*Description of a Standard Achromatic Microscope.*—The aim in the construction of this instrument has been to obtain the most perfect and effective mounting for the glasses of a microscope; portability and expense being of secondary consideration. The principles on which it is built, and the mode of using it, are fully described in the ‘Microscopic Illustrations.’ The perusal of that work, with the help of the following engravings, in which the latest improvements are represented, will enable any person to become familiar with its capabilities and to conduct satisfactorily the investigation of any department of science requiring the aid of the Microscope.

The optical part is so fully discussed by Dr. Goring in his works on the Microscope, that it will be unnecessary to enlarge upon it here, further than by stating that the object-glasses consist of combinations of pairs of cemented lenses, whereby the largest amount of penetration and definition are associated with the greatest space between the object and the front lens compatible with the perfect correction of achromatism and spherical aberration.

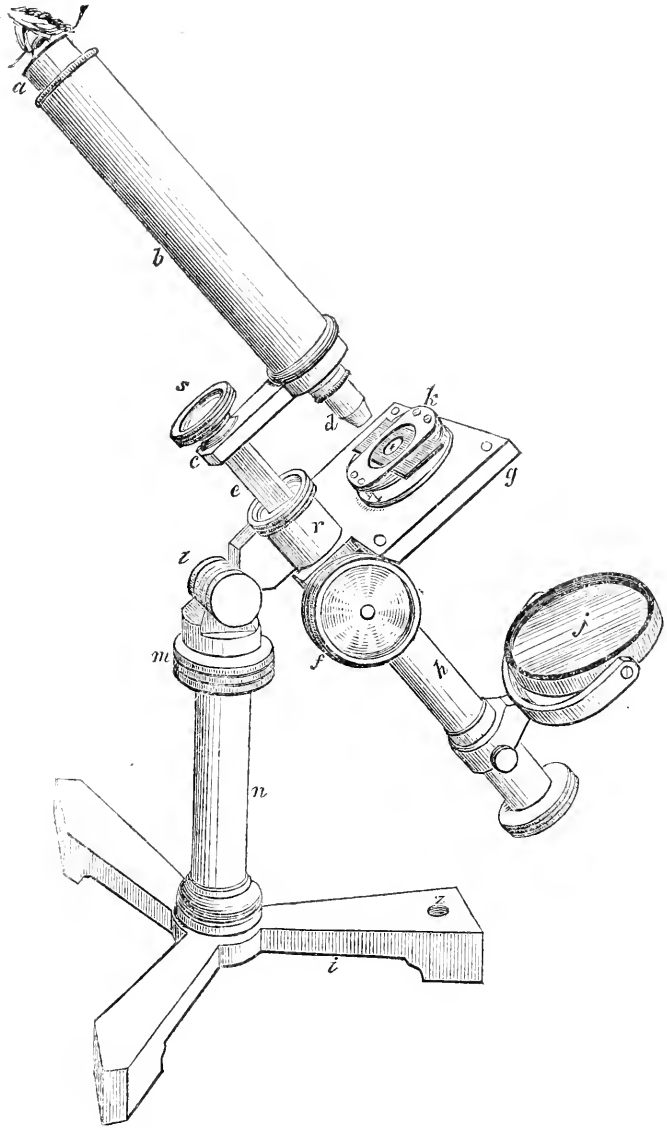

*Mr. Pritchard's Standard Achromatic Microscope.*

*Description of the Engraving.*—*a* is the eye-piece, *b* the body, *c* the arm into which the body screws. This arm and screw are sufficiently stout to carry the body without vibration, and therefore braces are unnecessary. *d* is the object-glass; *e* the triangular gun-metal bar, having a rack cut in its posterior truncated edge. This rack has a pinion working into it, the large triple-milled head of which is represented at *f*. The stage *g* has four holes at the corners, either of which will receive forceps, condenser, or other apparatus. The centre of the stage has an aperture one inch and a half in diameter, into which fits, by a bayonet-joint, the spring safety slider-holder *k*. This slider-holder has *two* moveable plates, so that in experiments with polarized light a plate of selenite inserted between them is not disturbed, while the slider with its object, which rests upon the upper moveable plate, is moved about. *h* is the stem of the microscope, which can be brought into any position, either vertical, horizontal, or inclined at any angle. It will also revolve about its axis within the socket *r*. This latter motion is of great importance, and no microscope defective in this particular can do half the work it ought. *j* the mirror; *n* the pillar, which consists of two tubes, one sliding within the other, by means of which and the tightening ring *m* the microscope can be raised or lowered at pleasure. *l* the solid tripod foot, which has its two posterior prongs squared so as to fit readily into a cabinet nine inches wide by seven inches deep. The anterior prong of the foot has a hole to receive an arm for carrying a

candle-holder, large condenser and shade, when required. The annexed engraving represents the same microscope in a horizontal position, with the stage turned a quarter round, so that open vessels of water of any depth containing small fish, insects, zoophytes, or aquatic plants,

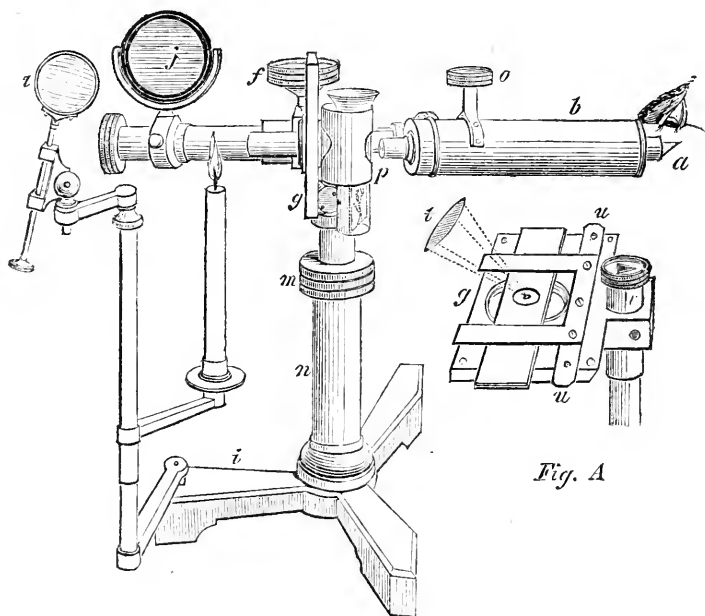

Fig. A

can be examined without removal. This engraving also shows the manner in which a camera lucida, attached to the eye-piece *a*, is used in drawing objects under the microscope. The same letters employed in the engraving in page 180 represent similar parts in this figure. *o* is the milled head for giving a fine adjustment to the focus, which for high magnifying power and the examination of delicate tissues is a necessary addition. *t* represents the

large condenser, which is attached to an arm that slides up and down the rod which supports the candle-holder. The figure *A* in the same engraving shows the manner in which large sliders are held upon the stage by means of the forked finger-spring *u u*.

The spring phial-holder *p* revolves within the tube under the stage *g*, so as to give any inclination that may be required. This phial-holder has a spring which forces the glass vessel forward, and thus, while it possesses the advantages of a safety slide-holder, enables us to use vessels of any diameter less than that of the containing tube.

The polarizer fits into the socket or tube under the stage *g*. This socket, which can be removed when not in use, also serves to hold diaphragms, achromatic and other illuminators, &c.

In employing a polarizing apparatus with this instrument, the best construction for the analyser is the single-image prism, which should be so mounted as to fit to the body *b* close behind the object-glass *d*. By this arrangement the field of view is always as large as the eye-piece will admit. This is a very important improvement, made by M. C. Chevalier upon Mr. Pritchard's original construction.

The traversing motions may be given to an object in this microscope either by the plan described in the 'Microscopic Illustrations,' page 105, or that given in this work, page 167.

It is unnecessary here to describe the various kinds of

apparatus which can be applied to this microscope, such as condensers, micrometers, dissecting instruments, camera lucida, micrometer and erecting eye-pieces, &c., as they are fully treated upon in the works before referred to. It may not, however, be amiss to mention that the cost of this Microscope varies greatly, according to the quantity of apparatus attached to it, and the number of object-glasses. When plainly equipped, the price is from twelve to fifteen guineas; and as additional lenses and apparatus can be applied at any time as the necessity for them arises, it is often better in the outset to purchase the instrument in its simplest form, rather than encumber oneself with a quantity of apparatus and glasses which may never be required in practice.

Table of the average Magnifying Powers of the Standard Achromatic Microscope, with complete sets of Object-glasses, given in diameters, and calculated by a ten-inch sight.

| OBJECT-GLASSES.<br>Focal lengths.  | Eye-pieces. |     |      |
|------------------------------------|-------------|-----|------|
|                                    | A.          | B.  | C.   |
| One inch . . . . .                 | 30          | 45  | 70   |
| Half an inch . . . . .             | 60          | 90  | 140  |
| One-third of an inch . . . . .     | 90          | 135 | 210  |
| One-seventh of an inch . . . . .   | 200         | 300 | 465  |
| One-tenth of an inch . . . . .     | 250         | 375 | 580  |
| One-twelfth of an inch . . . . .   | 350         | 525 | 820  |
| One-twentieth of an inch . . . . . | 500         | 750 | 1165 |

*Note.*—The above calculations are given from Mr. Pritchard's list of powers, furnished with his microscopes. They are much below those usually stated by opticians. Thus the power "300 diameters" in the above table is commonly called 400 linear or 16,000 superficial.

*Method of using Micrometer Eye Pieces.*—First, select



the object-glass you intend to use with this eye-piece, screw it in to the body, and fit in the eye-piece in the same manner as if it was of the ordinary kind; select your object, and bring it to a proper focus.

It is now necessary to examine whether the divisions on the Micrometer are distinct; if not, they are adjusted to distinct vision in the following manner:—Unscrew the diaphragm cap on the top of the eye-piece, and give the eye-lens one or two turns until the micrometer is brought into focus. The cell of the eye-lens has a very long screw to permit of this adjustment.

Having made your adjustment, the last thing to be done is to find the value of each division on the micrometer. Place on your stage instead of the object a micrometer divided into  $\frac{1}{100}$ ths of an inch or any other suitable division, which will depend upon the power of the object-glass. Let us suppose in this case the divisions of the micrometer on the stage to be  $\frac{1}{100}$ th of an inch, and that when looking through the instrument each of such divisions appears to cover 10 divisions of the micrometer in the eye-piece; it follows then, if an object be substituted for the micrometer on the stage, that each division which the object covers of the micrometer in the eye-piece will be equal to  $\frac{1}{1000}$ th of an inch. Suppose, as an example, it is desirable to measure the diameter of a hair, the apparent diameter of which in the microscope is five divisions of the pearl or glass micrometer in the eye-piece; it follows that the real diameter of the hair is equal to  $\frac{5}{1000}$ th of an inch, that is  $\frac{1}{200}$ th of an inch. If, how-

ever, in estimating the value of the micrometer in the eye-piece, it be found to be no equal number of divisions, then the value must be found by the rule of three. Example: If the division on the stage occupies  $15\frac{1}{2}$  divisions in the eye-piece, then to find the diameter of the hair, say—

$$\text{as } 15\frac{1}{2} : \cdot 01 \quad :: \quad 5 : \cdot 00322.$$

the real diameter of the hair.

For full particulars on this subject see 'Micrographia,' chap. ii. and Appendix No. 1.

*Note.*—After the value of the divisions in a micrometer eye-piece are determined, no change must be made in the object-glasses or variations in the distances of any of the lenses of the microscope: hence it follows that the adjustment to focus must be by the rack and pinion, and not by the fine-adjustment screw *o*. A table may be readily constructed showing the value of the divisions with each object-glass; and thus by mere inspection the real size of any object may be easily known.

## CHAPTER X.

### THE MEGALOSCOPE,

(*A new Optical Instrument.*)

BY THE LATE C. R. GORING, M. D.

THE *Megaloscope*, or, more strictly speaking, the *Megaloscopic Engiscope*, is an instrument for exhibiting the larger varieties of microscopic objects, such as aquatic larvæ, entire insects, minerals, shells, flowers, the machinery of chronometers, &c. The great mass of mankind will almost invariably be more delighted by an exhibition where they can see *the whole of an object at once*, though only moderately magnified, than by a display with a regular microscope, which shows only small detached parts prodigiously amplified. Indeed, I am almost ashamed to say that I myself belong to this unphilosophical part of my species; but I am not so unreasonable as to expect that opticians ought to be able to make a megaloscope which should exhibit the *whole* of a goose, jackass or elephant magnified a million of times, as some people I have met with do, not being aware, I suppose, that the more we magnify any object the less we must be content to see of it, according to the law of nature and optics, whatever may be the construction of the glasses we employ.

I once, however, met with a virtuoso in Hyde Park who seemed to have effected a sort of approximation in his own way to the kind of microscope the *οἱ πολλοί* wanted—and was making a considerably handsome collection of halfpence upon the strength of it. He was exhibiting a variety of large objects with a compound microscope of the old fashion, which might perhaps magnify six times, and requesting the observers to look through the instrument (which was placed horizontally) with one eye while they viewed Apsley House (*which was three-quarters of a mile off*) with the other, in order that they might form an idea of the stupendous powers of the splendid microscope submitted to their examination for one halfpenny. “Ladies and gen’lmun, just clap your hies to this ere vonderful and most stupenderous hinsterment, it magnifies nearly one million of times or I’m a liar and any of you may be kenwicted of the truth of what I says by lookin’ at the dimond-beedle with one hi, while you sees Apsley House with the hother. I’ll be blowed if the beedle bint bigger nor that, and all on you knows Apsley House is a million times bigger nor the beedle.” The audience seemed perfectly satisfied with this demonstration; for mankind are always much obliged to anybody who will be at the trouble of humbugging them in their own way, and fortunately there will never be a lack of persons to do them this kindly office. “*Où est le savan qui pour sa gloire ne trompera pas le monde?*” says J. J. Rousseau, putting profit of course entirely out of the question. With the exception of an exhibition once got up in

Regent-street, (in which the microscopes were all of the megaloscopic species, and also of the most cumbersome and unscientific construction,) and those of the peripatetic genus of microscopists, who, knowing right well how to cater for the taste of the multitude, also patronize the megaloscope,—engiscopes of low powers, though by far the most amusing and in many cases the most useful instruments, also seem to have been quite neglected, while the high powers have been brought to the greatest perfection of which perhaps they are capable. It is necessary, however, that both extremes should be equally improved, and the finishing stroke will not have been given to the radical reform of microscopes till this is effected. It is the sentiment of many that we have been dosed with improvements on the microscope *ad nauseam usque*: the scrapings of the bowl, however, must and shall be swallowed, though Messrs. Rococo and Micronous of the Spectacle-makers' Company insist upon it that everybody who makes an improvement on the microscope ought to be complimented with thirty good whacks with a bamboo on the most fleshy part of his person, just as in the celestial and unchangeable empire of China, every one who makes or pretends to make an improvement or adopts any novelty in ship-building is\*; and all who have seen Chinese junks of war must admit that the best of our ships cannot be compared with or talked of in the same day with them—which is no doubt the excellent

\* Captain Basil Hall is my authority for this.

result of this wise regulation. Moreover, they quote the Roman emperor Tiberius, (one of the most politic and sagacious men who ever lived,) who ordered an artist to be flung to the wild beasts in the amphitheatre for inventing a curious kind of flexible crystal glass, of which he presented a goblet to the emperor, then flung it down on the marble pavement without breaking it, and afterwards hammered out the dinge it had received as if it had been metal.\* The wise emperor justly thought this rascal would not have cared had he deprived of bread all the makers of metal drinking-cups, and their families, provided his own trade had flourished; and therefore, in his paternal consideration for the welfare of his subjects, passed the humane sentence mentioned above, *in terrorem* of all improvers of glass-works. Now Messrs. R. and M. most justly complain that the trade in microscopes is perfectly ruined and worthless, from the eternal nick-nackery which is going on now-a-days in that branch of business. A variety of articles is introduced which are so difficult to make, and put off so much time, that "*they don't pay at no price;*" the public not appreciating them at anything like the true cost. Formerly £20, £30, and even £40, was obtained for compound or lucernal of the good old simple construction; *and the half was profit.* Now they cannot obtain more for instruments whose prime cost to the shopkeeper is double, and consequently

\* I cannot recollect my authority for this, but it was a Latin author quoted in a description of Pompeii, proving that the Romans made window-glass.

little or no profit is to be got. These evils call for a serious remedy. The Chinese one is rather too severe for a free country, and gladiators and venations are out of fashion just now; but I think all mischievous improvers might have their persons tarred and feathered and their faces chalked: they should then be paraded about astride of a pole (not too finely planed or polished and well pelted with sheeps' eyes and rotten eggs,) though, after all, nothing should be considered a *real* improvement which is not a good shop article. I cannot refrain from remarking that the punishment I have just recommended may in the opinion of some be thought admirably adapted to constitution- and democracy-manufacturers, who would tolerate no absolute government in heaven, or any genuine republic on earth (for a true republic and a mobocracy or canailleocracy are two very different things).

A truce, however, to these digressions. I suppose it will be admitted that if it is worth while to do a thing at all, it is worth while to do it well; and, if well, I presume as well as possible. Now it has always been my aim, in all the constructions of optical instruments I have laid before the public, to contrive everything for the best, as far as my abilities would permit. Neither have I been inattentive to economy; for I have recommended nothing superfluous; and where, of two modes of doing a thing equally well, one is easier and consequently cheaper than the other, I have given the preference to the least expensive. This is very different from the practice of a regular trader; who always endeavours to select a showy con-

struction, and one at the same time which has no difficulties in its execution. It will therefore be executed rapidly, by ill-paid rubbishing workmen—impose on the public by its outward appearance—and afford a *good profit*—which is all that is cared for.

#### OPTICAL PART.

In a Megaloscope, I consider that the aim is to obtain a low power, connected with what is called a large field of view. By this I mean not only a field of a great number of degrees of opening, but which also takes in a large portion of the object. Now we shall find in experimenting that there are certain limits to these qualities, which cannot be passed without detriment to others equally important. Thus, suppose we select an object-glass of long focus, in order to obtain a low power; the length of the body must be proportional (which counteracts the effect of a long anterior conjugate focus); moreover the field will not fill with a shallow eye-glass, unless the body has a certain length, and a deep one neutralizes the effect of the shallow objective part. Again, a shallow eye-glass *per se* requires a long body, *even with a deep object-glass*, or it will not fill at the edges of the field, which, moreover, will be distorted and confused at the margin, and have its central focus much longer than the marginal one. A certain proportion between the lengths and size of the body and the foci of its objective and ocular part, being thus always forced upon us, (when at least we wish to have a good



and large field of view and all the optical properties of the instrument what they should be,) we can only gain an advantage one way to lose it another, if we kick against these laws of optics.

I once attempted to make a megaloscope as follows :—the object-glass was  $2\frac{1}{2}$  inches focus and  $\frac{3}{4}$  of an inch in aperture ; the body, I think, 8 inches long or less ; the two field-glasses were each 3 inches focus and  $1\frac{7}{8}$  in. in aperture, placed in contact. The figures were plano-convex, with their plane surfaces next the eye ; the eye-glass was one-inch focus, plano-convex, the plane side next the eye, and only one inch distant from the anterior field-glass, which was consequently in its focus. Now this construction was excellent in some points : its field of view was very large— $70^\circ$  I think—quite free from distortion and indistinctness at the edges ; and, as the anterior focus of the objective part was longer than the posterior, the image was a diminished instead of a magnified one, and the power of the entire instrument very low, being, if I rightly recollect, only half of that of the eye-glass, or equal to a lens of 2 inches focus.

What were its faults ?—Why, first, the anterior field-glass being in the focus of the eye-glass, all the imperfections, scratches, and particles of dust, &c., on the former were visible ; secondly, the doubling of the field-glasses (for no single one would answer) caused the vision of opaque objects to be very dull and unsatisfactory, as is always the case with double field-glasses and eye-glasses. (We may double and treble object-glasses without doing

sensible mischief, but not eye- and field-glasses, especially the latter.) I gave this megaloscope to the late Mr. Wm. Tulley of Islington, who set very little store by it, as well he might; it served to amuse his children, who easily managed it, as, from the great length of its anterior conjugate focus and small size, it might be held in the hand, and did not want a stand.

When a megaloscope is properly constructed, and has all the optical excellencies it should have, its lowest power will be about equal to that of its eye-glass: that is, the image formed by the shallowest objective will not be a magnified one, but of the same size as the object; consequently it will be capable of taking in an object not superior in size to the field-bar of the eye-piece, whatever it may be.

Now as I do not think it is of much use to view objects with a magnifier of less focal distance than 2 inches, that power may be pitched upon for the lowest of the megaloscope; and the instrument I propose to describe has its proportions regulated accordingly.

*a, b, c, d* (fig. 1), is the optical part of the megaloscope,  $2\frac{1}{2}$  inches in diameter and about  $1\frac{1}{2}$  inches long, reckoning in the eye-hole, which screws on at *a*, and is represented at fig. 2; the eye-glass is 2 inches, the field-glass 4 inches in focus; the object-glasses are three in number and situated in the part *c, d*, and may be used together or separately. The object-glass at *c* is  $3\frac{1}{4}$  inches focus; the other two are of the same focus ( $4\frac{1}{2}$  inches), and are set in the same cell, giving a combined focus of

about  $2\frac{1}{2}$  inches ; their aperture is 1 inch. The glass at *c* is fixed in a separate tube, and made to slide within

Fig. 2.

Fig. 1.

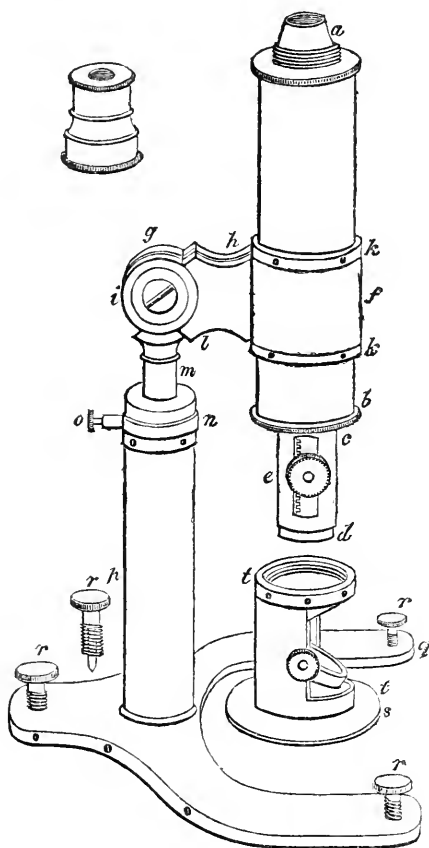

*Goring's Megaloscope, one-sixth its real size.*

that which holds the others ; thus it can be used either at a certain distance or in close contact with them ; in the latter case the power of the combination is double what it is in the former. These three glasses are all achro-

matic, and should be so constructed that they will act either together or separately. A stop  $\frac{3}{4}$  of an inch in diameter is made to slide into the exterior tube, and to be removed at pleasure. *This will in no degree diminish the size of the visual pencil or penetrating power of the glasses, when they are all in combination, though it greatly reduces the quantity of light, or what may be termed the intrinsic brightness of the image, while it increases wonderfully its distinctness; and for this purpose it may be advisable to use it occasionally, though the combination is abundantly distinct without it on any opaque objects not of extraordinary brilliancy, such as globules of mercury, diamond beetles, and certain minerals. I need not observe, that when the two glasses in front at *d*, only are employed, the said stop reduces their aperture, and with it the size of the visual pencil and the penetrating power.* The focus of the body is adjusted by moving the milled head at *e* backwards and forwards; the entire body may also be moved in its containing tube *f*, if micrometers are applied to the field-bar, whose value it is not wished to disturb.

As this instrument has a very shallow eye-piece, its visual pencil is of considerable length; thus camera lucidas, rectangular and other prisms,\* plane metals, at different angles, may be applied *comfortably* to it *without preventing us from seeing the whole field of view*, as they

\* A prism of  $60^\circ$  throws out a pencil at a very convenient angle for observation; and the visual pencil of a megaloscope is long enough to permit the employment of it, and allow the whole field of view to be seen at once. That portion of the lower part of it,

are very apt to do in instruments having deeper eye-pieces. This will be found a great advantage in many cases, as the powers of a megaloscope are frequently those best adapted for drawings, giving general views of objects.

The body of the instrument I am describing, and which is now before me, is made of a very stout brass tube, so that when the glasses are in their places, it weighs three pounds, which requires the stand to be stout in proportion. I should be very much disposed to make the tube of that kind of pasteboard, and in the same way, that I have seen the tubes of common Dutch telescopes made, which answer sufficiently well. Moreover, I should have both the eye- and object-glasses set in wood, instead of metal, as they are in the Dutch spy-glasses aforesaid. This arrangement would make the body so light that the stand of any ordinary engiscope might be adapted to it. Moreover I would make the main tube 3 inches in diameter instead of  $2\frac{1}{2}$ , by which the field of view might be enlarged; for no large field of view can be obtained without a large field-glass, and consequently a large body: that of the present instrument is only of the usual size of that of engiscopes with single field- and eye-glasses, and if it could be made larger, it would certainly be much more agreeable.

or that in contact with the eye-glass, which projects and is not in action, may be cut away for convenience. I think, moreover, that a prism of  $60^\circ$  reflects much the same quantity of light whether it is silvered or not on the reverberatory surface.

The idea has often occurred to me, that as flint-glass is now made on the Continent of a very high specific gravity, and at the same time free from veins and of the most perfect clearness and transparency, it might be employed in making the eye-pieces of both telescopes and microscopes, and would have the effect of increasing the size and bettering the edges of the field of view, somewhat after the manner that doubling the glasses does—that is, by reducing the spherical aberration of the edges from the shallower curvature they would require for any given power, *while the achromatism of negative eye-pieces could always be preserved as usual.* But it must not be supposed that I recommend this for positive eye-pieces, or single ones of any kind, as the high chromatic dispersion of such flint-glass could not in these be corrected, and would neutralize the advantages procured by diminishing the spherical aberration. Neither can I be answerable that the advantages obtained by using flint- instead of plate-glass would be sufficiently sensible to be appreciated by the eye. I intend, however, to have the experiment tried. I have a plano-convex lens of half an inch focus, made of the dense flint-glass of Guinand, which I think gives a sensibly larger and better field of view than one of equivalent focus and the same figure made of plate-glass, which latter of course has a deeper curve. It is certain that it ought to do so according to theory.

I had nearly forgotten to mention that the shallow object-glass at  $e$ , when used alone, must always remain

*in situ*, the other two being taken out. It (the shallow object-glass) need never be removed, except when the front glasses are wanted to act separately. The stop should also be left in the tube when the shallow object-glass is in action : it prevents extraneous rays not proceeding from the object under examination, and those reflected from the inner surface of the tube, from being refracted. I need scarcely observe that the rays from near objects not being parallel but divergent, the said stop, being pretty near the focus, does not cut off any of the aperture of the object-glass or reduce the size of the visual pencil.

The object-glasses make delightful hand-magnifiers, or, in strict language, achromatic microscopes : their inner surfaces being cemented and their aberration of both kinds neutralized, we see through them as if we were looking through a piece of plane glass.\*

#### MECHANICAL ARRANGEMENTS.

It is obvious that a Megaloscope may be mounted in the same manner as any other engiscope; only it will require a very strong and massive stand. I am disposed to think, myself, that one chiefly made of wood answers *well enough*; but of course everything of this sort which can be executed of wood, can be executed in metal at pleasure, reducing the dimensions in the ratio of the

\* I ought to state, for the information of the reader, that the optical part of this Megaloscope was made at Mr. Pritchard's manufactory, 162, Fleet-street, London.

strength of the material employed. The stand I am now going to describe is of a very simple nature; yet it might perhaps give satisfaction to many observers with ordinary engiscopes having high powers. It is made of metal, and on a small scale. *Fig. 1* (p. 195), *g* is a hinge or cradle-joint, with a long neck made of sycamore or any other close-grained wood, and of course sufficiently substantial; the tube, *f*, into which the body is inserted, is lined with brass in the inside, like the first joint of a spy-glass, and moreover strengthened by two ferrules *k, k*, on the outside, which are screwed to the interior tube. The neck is likewise strengthened by a piece of veneer, *h*, let into it, so that its grain shall cross at right angles that of the recipient part, into which it is carefully glued. The inserted piece must not be too thick, or it will give the joint a tendency to warp. The two external cheeks of the hinge are of the same thickness and strengthened in the same manner. A brass washer is placed on each side, and a metallic screw passed through the whole. The joint may be put together with a little chalk, or with powdered resin if not stiff enough, or with black lead, or some of that magnesian fossil called mountain soap,\* or French chalk, similar to that used to make pencils to write on glass, if

\* A German organ-builder once showed me a substance which he said answered admirably for smearing the stops of his instrument, as it gave all the lubricity of black lead *without being amenable to the action of the weather* as black lead is. He knew not what it was; but I think it was that magnesian fossil called mountain soap.



required to work easily. It will be remarked that, however heavy the body may be, it can always be balanced by sliding it in its containing tube; and when it is quite vertical, and its whole weight, aggravated in effect by the lever of the neck, strains the cradle-joint, the body will be retained in its position by the projection at *e*, on which the neck will rest. *m* is a sliding-rod of wood; it passes into the pillar *p*, and is retained in its position by the pinching-screw which is attached to the cap *n*. The screw acts upon a spring adapted to the shape of the rod in the inside of the wooden tube or pipe, which is perforated from end to end. The pillar is wedged and glued or screwed into the wooden furciform tripod frame *q q*, which may be made solid or in two pieces; it can also be made of pewter (painted in oil in imitation of wood). This tripod frame has its inner contour circular, but its two prongs project straight a little way beyond the centre of gravity of the body. Three screws, *r, r, r*, are fixed into the extremities of the stand, made of ivory or hard wood; holes are drilled into the ends of them, and pieces of black lead or French chalk are inserted (as in the patent pocket-pencils). See the detached one. If the reader should want to know the use of these pencils, I beg to inform him that the instrument is to be placed on a piece of good Irish slate, or a polished plate of copper, or one of glass; (the first gives the most friction, the latter the least;) and that grasping the pillar at the bottom he is to slide the instrument about thereupon at his pleasure, over the

object placed on the stage *t*; or if he does not like that, he may attach three bits of black lead to the bottom of the said stage, and slide that about instead—I care not which. As to the said stage, it is a very simple affair—just a hollow cylinder of wood or tin, with a flat bottom, and a plane mirror in it moving in one direction and turned round to the quarter the light comes from. I myself prefer the following arrangement, which dispenses with the stage. Get a small table of appropriate height, so that when the instrument is placed upon it the eye-piece shall meet the eye comfortably; the top of it is to be made of slate with a hole in it about three inches in diameter, to allow light to reach transparent objects placed over it. Under this table there must be a shelf or stage, on which you place a small dressing-glass, to reflect light upwards. Here is your apparatus complete. By means of prisms you can observe looking either horizontally or at an angle of  $45^\circ$ . What would you more? The whole concern will make a very good ornament for a lady's boudoir.

Fig. 3.

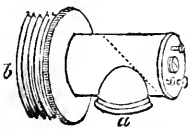

Fig. 6.

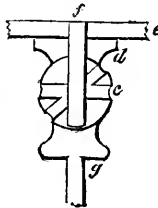
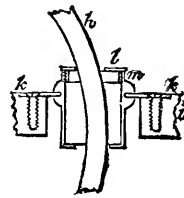

Fig. 5.



Some persons, however, are fantastical and fastidious, don't like prisms, and must have everything done in a philosophical manner. To such I recommend the follow-

ing apparatus. First, then, is fig. 3, consisting of a tube containing either a rectangular prism or a plane metal, to

Fig. 7.

Fig. 9.

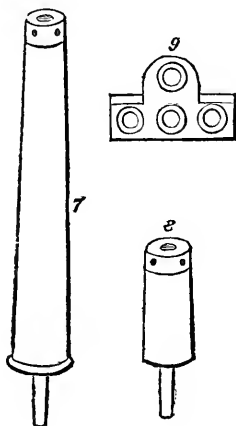

Fig. 8.

which the tube *c, d*, fig. 1 (p. 195), with its adjustment and the object-glasses, is to be screwed at *a*, the end *b* being adapted to the screw at the objective end of the body *b*, fig. 1, which is then equipped for action in a horizontal position; only you must adjust it to the height of your eye by drawing the rod *m*, fig. 1, up or down, and then fix it by means of the pinching-screw; the height will of course depend upon your own and that of the chair and table you make use of, and also upon the focal length of the object-glass employed. All you want now is something to raise the stage up to the corresponding elevation, and then everything will go on much as before. Now this you shall have. You see that ball at *c*, fig. 4, (a section of it is shown at fig. 6, p. 202): it is an excellent substitute for a cradle-joint, and may be used instead of that already described in fig. 1, *g*; it has three holes in it,

one vertical, one horizontal, and one at an angle of  $45^\circ$ . You will seldom want a greater variety of positions, or

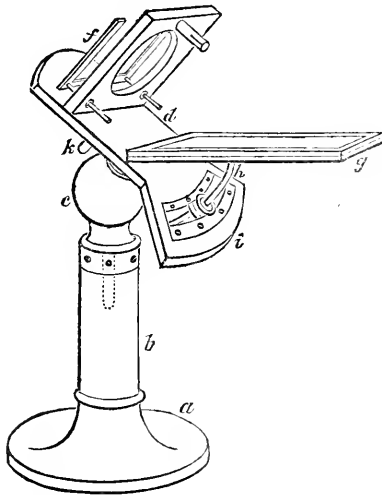

Fig. 4.

make use of them, if you have a regular cradle-joint. Well, then, fix the pin under the stage of fig. 4 into the vertical hole, and you will have a flat table to place the stage *s*, fig. 1, upon, which you will then find will be about the proper height; if it is not, you can easily make it so with a book or a piece of board: you had better remove the frame and object-holder *d*, *e*, fig. 4, as it will be in the way; it will easily twist out of the hole at *k*.

In case, however, you should wish to observe *with the object-glasses under the stage*, as in the case of viewing crystallization of salts,\* you must turn the body round till the object-glasses are uppermost: and then a farther

\* Microscopic Illustrations, page 191.

augmentation of the height of that part of the apparatus which carries the object to be viewed will become necessary. The table (*i*, fig. 4) must now be placed in a vertical position, with the mirror (*g*) uppermost, which is effected by putting the pin under the said table into the horizontal hole in the ball. The right elevation will be obtained by removing the pin (*g*, fig. 6) from the pillar (*b*, fig. 4) and inserting the stilt or lengthening piece (fig. 8) between them, which must accordingly be made of the requisite length.

For such as may still be dissatisfied with these modes of observing, who reject the use of plane mirrors and prisms in any form in the optical part of the instrument, and are content with using the instrument horizontally or at an angle of  $45^\circ$ , the apparatus represented in fig. 4 is more particularly contrived. It is so made that when the body is inclined at an angle of  $45^\circ$ , and the rod (*m*, fig. 1) as low down as it will go, the stage will be at right angles to the optical part, and its centre adjusted to it; at least it can be very readily made so to be, by levelling the body in the direction of a line drawn from one end of the table to the other. Its construction is so simple, that its appearance ought to explain it; except perhaps that of the mirror, which I shall therefore describe. *g* is the mirror in a strong but light wooden frame, having the back pretty thick and firmly screwed on, and moreover strengthened in the middle by a plate of brass carefully fixed on. This mirror is attached to the stand by means of a hinge, which is shown at fig 9 of half the real

size, and which by the action of the joint and the pivot which fastens it down allows a double motion to the mirror. Two plates of brass curved to the requisite radius are firmly fixed by 8 screws in each to the table; their arc is  $90^\circ$ . *h* is a square arched piece of brass of the proper curve, suited to its distance from the pivot of the hinge, which passes into a brass box stuffed with cork, and on the outside of which is turned a circular groove, into which the edges of the two pieces of brass are fitted, so that the box shall traverse between them as the mirror is turned round on its pivot, but at the same time not too easily, which is effected by making the two plates spring a little in opposite directions. At fig. 5 (p. 202) is a section of this apparatus of half the real size. A pinching-screw and spring may be substituted for the piece of cork, if preferred; and an ordinary mirror of double action may be used, instead of the form here described, by those who like it better; but it will not act so well unless of unseemly dimensions in many cases, especially in throwing light downwards when the object-glasses are posited underneath the stage, or in affording that beautiful lateral or black ground illumination recommended by Rev. Mr. Reade (in his Essay published in the 'Micrographia,') and which certainly brings out the colours of transparent objects better than any other. To effect this with the present apparatus, it is merely requisite to turn the stage round a little on its pin (*k*), and to fix the body at right angles to its plane. In this position, then, the natural action of the mirror will give

the kind of light wanted, and from its length will be sure to fill the largest field with the lowest power with it. I do not think condensers or concave mirrors necessary with the Megaloscope, because its own natural light is so great.

There are few, I think, who must not have observed the beautiful effect produced by the mild radiance of the declining sun streaming through the glades of a forest, and lighting up the blades of the grass and the leaves, and on the majestic trees, with that indescribably brilliant and tender green which can be compared to no other earthly green. Now if we examine into the nature of this illumination, we shall find that it is always lateral and oblique—in short, just of the same nature as that called the black ground illumination; only the rich yellow light of the sun, when it is sufficiently low down in the horizon to permit our eyes to gaze on its disc with impunity, far surpasses in beauty anything else we are acquainted with; whatever transparent objects it may illumine it touches with a heavenly tint, which has been the theme of poets in every age and country.

I have repeatedly observed, and all microscopists know, that the full light of the sun cannot be modified so as to suit microscopic purposes. It gives to opaque objects especially an appearance of being inlaid with mosaic work composed of myriads of gems of extreme minuteness, and the most vivid prismatic colours; the higher the power we employ is, the more striking is the phenomenon. Nevertheless I am disposed to think that *transpa-*

*rent objects* may be viewed with the *low powers of the Megaloscope* (without producing any sensible optical deception) by the light of the sun as modified by passing through the denser part of the atmosphere in contact with the earth, when the disc is perhaps only  $20^{\circ}$  high above the horizon, or thereabouts; and it would be a great pity if they could not, for still more beautiful are those leaves, and those blades of grass, and those rich mosses, and the petals of those wild flowers, when viewed by the Megaloscope than by the naked eye, and still more delight do they occasion to the senses of the observer. Nothing is more simple than the mode of managing the Megaloscope with this simple illumination. We have only to mount it horizontally, and then tilt it, till the sun's light falls at the required angle on the object, and to place a needle equipped with a disc of black velvet stuck on cork, large enough to form a ground to the whole field of view, at a little distance behind the body under examination, but of course so posited as not to intercept the oblique rays of the sun. If some such arrangement is not made, the field may chance not to be black, but of some other colour—green, for example, if there is a green field between your instrument and the sun; in fact you may make the ground of what colour you like by using coloured discs; a bright cobalt blue makes, I think, a beautiful ground for green objects, and green for red or crimson ones, &c.

As the light of the sun is not always to be had, I have attempted to modify the natural light of that body



when high up in the heavens to a similar state, by means of a prism, and certainly the yellow light thus obtained is as rich as that of the setting luminary ; but there is a harshness in it—a want of mellowness, owing to its not having passed through a long dense stratum of air, which cannot be got rid of ; the same may be said of that afforded by passing the solar light through coloured glasses. We may, however, I suppose, indulge ourselves by using all the different prismatic colours, and those of coloured glasses also, if we like, for pleasure's sake, as the Megaloscope can never be considered as an instrument of discovery, but one for amusement only.

If I rightly recollect, Mr. Jim Crow thought he had given a very sufficient reason for using oyster-sauce to his beef-steak, instead of eating it plain, (in which way it would have been quite as nourishing, and many think more wholesome,) by saying, with a grin from ear to ear, "*Cos um so deliful.*" Upon no better principle can we be justified in saucing our objects with these rich lights, instead of using plain and simple ones.

There is another way of using the Megaloscope—which is in a horizontal position. In this case the stilt, fig. 7 (p. 203), is inserted between the pillar *b* of fig. 4 (p. 204), and the table *c* of the same figure. The latter being made horizontal, the body can be presented to the front of the stage at *f*, or the stage may be turned round on its pin, and a taper placed behind it. There is an inconvenience in this mode of mounting (and also in fig. 4) ; which is, that when you move the frame about to go over your

object, it can only do so in a horizontal direction ; you must get the opposite motion by moving the body vertically by means of the cradle-joint, or by lifting the rod *m*, fig. 1, up and down in the socket.

It will not be found that (though the stage in this construction is frequently stilted up very high,) any tremor will be produced, because it is always stationary ; neither will it be very liable to be knocked down, for the foot of the pillar *a*, is made of pewter, and may be made as heavy as we like.

It will be observed as a peculiarity in the mounting of the Megalosopic Engiscope, that the illuminative apparatus, as well as the stage, is in all cases detached from the body—an arrangement which seems to me to yield many facilities and comforts to the observer in a variety of instances, without doing any mischief. For my own part, were it not for the weight of the instrument, and the fatigue and inconvenience of perpetually holding it in my hands, I could use it on opaque objects without any other apparatus than fastening it to a slip of wood ; but I have always found that when the body, or any part of it, is constrained or incommoded, we never can observe anything with exactness, and what ought to be a pleasure and amusement becomes a wearisome task.

THE END.

~~~~~  
The Microscopic Preparations described in this Work may be  
obtained at Mr. Pritchard's Manufactory, 162, Fleet-street.  
~~~~~



