

**MID-PACIFIC OCEANOGRAPHY**  
**Part IV, Transequatorial Waters,**  
**January-March, 1952**



**SPECIAL SCIENTIFIC REPORT-FISHERIES No. 135**

SH  
11  
.M52  
no. 135

**UNITED STATES DEPARTMENT OF THE INTERIOR**  
**FISH AND WILDLIFE SERVICE**

### Explanatory Note

The series embodies results of investigations, usually of restricted scope, intended to aid or direct management or utilization practices and as guides for administrative or legislative action. It is issued in limited quantities for the official use of Federal, State or cooperating Agencies and in processed form for economy and to avoid delay in publication.

United States Department of the Interior, Douglas McKay, Secretary  
Fish and Wildlife Service, John L. Farley, Director



MID-PACIFIC OCEANOGRAPHY, PART IV

TRANSEQUATORIAL WATERS

JANUARY-MARCH 1952

By

E. D. Stroup  
Physical Science Aid  
Pacific Oceanic Fishery Investigations  
Honolulu, T. H.

Special Scientific Report: Fisheries No. 135

WASHINGTON: AUGUST 1954





## CONTENTS

	<u>Page</u>
Introduction .....	1
Vessel, equipment, and procedures .....	1
Some results of <u>Hugh M. Smith</u> cruise 14 .....	2
Computed currents .....	3
Temperature .....	3
Sigma-t .....	4
Salinity .....	4
Phosphate phosphorous .....	4
Acknowledgements .....	5
Literature cited .....	6
List of figures .....	7
Notes on tabulated data .....	19



## Introduction

This report is concerned with cruise 14 of the M/V Hugh M. Smith, the fifth in a series of equatorial oceanographic cruises by the Pacific Oceanic Fishery Investigations of the U. S. Fish and Wildlife Service.<sup>1/</sup> The cruise was carried out in January and February 1952 in conjunction with longline tuna fishing in the same area on cruise 11 of the M/V John R. Manning; the results of the fishing have been described by Murphy and Shomura (1953). The purpose of these simultaneous operations was to help relate the occurrence of tunas to the oceanography of the upper layers in the equatorial Pacific between 155° W. and 180° longitude.

Measurements of surface and subsurface temperature, salinity, and inorganic phosphate as well as plankton collections were made during Smith cruise 14. The purpose of this report is to present the tabulated station data and various vertical sections, with minimum analysis of results. There are, in addition, brief descriptions of one of the smaller features of the area. The results of the plankton collections will appear in later reports.

## Vessel, Equipment, and Procedures

The shipboard equipment was essentially as described by Cromwell (1951), except that the hydrographic winch and work platform were raised to a safer and more workable location on the boat deck, about 6 meters above the sea surface (see frontispiece). The main-deck laboratories were also redesigned for greater convenience. The methods of collection and processing of the raw data have been described in detail (Cromwell 1951, 1954).

The treatment of the observed data from Smith cruise 14 leading to their ultimate presentation as interpolated data and vertical sections differs somewhat from the previous cruises. Smith cruises 5 and 8 (Cromwell 1954) and 11 (Austin 1954) were presented using modifications of the methods proposed by Montgomery in his evaluation of a Smith cruise 2 section (Montgomery 1954). The procedures used in the analysis of Smith cruise 14 are, in effect, an extension of Montgomery's method, embodying, in addition to the methods he employed, several further details suggested in his paper. An outline of the method of analysis will be given here; reference to the reports above (especially Montgomery 1954) should be made for detailed discussion and theoretical consideration.

The basic representation of each oceanographic station was made on a graph embodying a temperature scale vs. scales of depth, salinity, and phosphate phosphorous, with lines of constant sigma-t corresponding to the temperature and salinity arguments also included on the graph (fig. 1). Temperature-depth curves for each station were first drawn, passing through the values obtained from the reversing thermometers but utilizing the shape of the station bathythermograph (BT) trace to define detail in the upper 270 meters. Temperature-salinity and temperature-phosphate curves (station "characteristic curves") were then drawn. Values from adjacent stations, and in many cases from stations two or three removed on the same longitude, assisted in construction of the curves between observed points; this was readily accomplished by superposing the station graphs on a light table during the drawing. The necessity for this procedure is evident in an examination of the vertical sections (see below). The depths sampled by the Nansen bottles (entered as dots on the sections) necessarily often miss some of the major features of the distributions, especially in the region of the thermocline, but by utilizing adjacent-station values the continuity of these features is not destroyed. The variations in these characteristic curves with latitude were made as regular as possible, and, so far as the observed data permitted, maxima and minima were located on the same respective values of sigma-t from station to station.

---

<sup>1/</sup> Certain results of the previous cruises in this series appear in reports by Cromwell (1951, 1953, 1954), Austin (1954), and Montgomery (1954).

Depths of sigma-t, salinity, and phosphate phosphorous at the desired isopleth values were taken from each station graph by referring to the common temperature scale and the temperature-depth curve, and each of these properties was plotted on a meridional section. Temperature sections to the same scales of latitude and depth were drawn for each station line of the cruise from the complete BT data (these were used in the analysis but are omitted here in favor of temperature sections with greater vertical exaggeration). The plots of sigma-t were then placed over the temperature sections on a light table and the isopleths were drawn, allowing the grosser detail of the temperature sections to influence the sigma-t sections between stations. The salinity and phosphate phosphorous plots were next drawn over the sigma-t sections in a similar fashion, with their isopleths made as nearly as possible parallel to the isopleths of sigma-t. In view of the extensive adjusting of the characteristic curves to obtain continuity between stations, the interpolated values of sigma-t, salinity, and phosphate phosphorous plotted on the sections were followed exactly during the drawing.

Values of temperature and salinity at standard depths were taken from the station graphs for use in the computation of geostrophic currents. The values of sigma-t tabulated at standard depths were computed from these temperature and salinity values, rather than read directly from the station graphs.

The most evident new procedure, that of allowing the BT temperature sections to influence construction of the sigma-t (and thus salinity and phosphate) sections, has been instituted to achieve consistency between the distributions of temperature and density, and internal consistency in the method of analysis. It is certainly not argued that all the detail thus introduced into the density distribution is meaningful from every point of view, but a more accurate presentation of the observed field of density is obtained than by merely drawing smooth curves through the station points. As a practical consideration, it is a great deal easier to include all the larger detail than to set up any arbitrary criterion for smoothing which would then have to be invoked continuously during the drawing of a section.

The method of mutual adjustment of the station characteristic curves is based on the fact that the ocean is continuous; with the present sampling methods this assistance between stations probably gives a closer representation of actuality than methods treating each station individually. The location of the maxima and minima of these curves on continuous values of sigma-t from station to station, and the subsequent drawing of the isopleths of the salinity and phosphate sections parallel to the isopleths of sigma-t, are based on the consideration that flow in the ocean normally takes place along surfaces of constant potential density, which are closely approximated by surfaces of constant sigma-t, and that mixing of by far the greatest magnitude takes place along these same surfaces.

#### Some Results of Hugh M. Smith Cruise 14

The station pattern for Smith cruise 14 appears in figure 2. The stations along 155° W. longitude consisted of casts to at least 1,000 meters; to permit greater definition of detail in the region of interest the other two lines of stations were mostly limited to the upper 700 meters. Figures 3 to 7, describing the section at 155° W. longitude are in the sequence: dynamic topography, geostrophic currents, temperature, sigma-t, salinity. The second series of figures (8 to 11), describing the section at 180° longitude and the third (12 to 15), describing the section at 169° W. longitude are in the sequence: temperature, sigma-t, salinity, phosphate. Figure 16 presents temperature sections on 155° W., 169° W. and 180° longitudes, taken on the fishing station lines of John R. Manning cruise 11.

The numbers and positions of the stations are indicated on each section. For each variable except temperature, the location of every observation carried in the tabulated data is indicated by a spot on the vertical section in question. When there was serious doubt regarding the accuracy of an observation, it was not used in constructing the vertical section, and a footnote to this effect was entered in the tabulated data. Observations unquestionably in error were dropped from the tabulations.



To make the relations between the different fields more readily apparent, selected isopleths of  $\sigma_t$  have been plotted as dashed lines directly on the vertical sections of salinity and phosphate and on the section of computed currents. The two shallower isopleths roughly define the upper and lower boundaries of the strong density gradient in the thermocline.

Comparison of the temperature sections from Smith cruise 14 and Manning cruise 11 indicates that changes in the minor features of the various distributions may be quite rapid; this has been verified by the results of a subsequent cruise (Smith cruise 15, Austin MS.). For this reason no attempt has been made to plot any form of horizontal distribution over the area covered by Smith cruise 14.

It should be noted that the winds, atypically, were predominantly north of east over the entire area during the period of the cruise (wind data are listed for each station in the tabulated data).

Computed currents--As indicated above, only the stations along  $155^\circ$  W. longitude were of sufficient depth to permit computation of geostrophic currents relative to a 1,000-meter level of no motion (except for three stations on  $180^\circ$  longitude, see below). The smoothed dynamic topographies of selected isobaric surfaces with respect to the 1,000-decibar surface are shown in figure 3; the computed dynamic heights at each station are carried as dots. Owing to equipment malfunctions the observations at  $0^\circ 54'$  N. latitude and  $3^\circ 00'$  S. latitude were too shallow to permit computation relative to this surface. From these smoothed topographies the currents shown in figure 4 were computed. The computation of currents becomes highly uncertain, and is not attempted, within  $3^\circ$  of the Equator.

In the surface layer, the Equatorial Countercurrent is found from the northernmost station at  $8^\circ$  N. latitude to the southern boundary at  $4^\circ$  N. latitude; the Smith temperature section on this longitude (see below) indicates the northern boundary at approximately  $9^\circ 30'$  N. latitude. The westerly South Equatorial Current is found south of  $4^\circ$  N. latitude.

The three southernmost stations of the  $180^\circ$  longitude line reached 1,000 meters, and computation of dynamic heights of isobaric surfaces relative to this level have been carried out; these are carried in the tabulated data but not in a figure, and no currents have been computed. Examination of the data indicates that the currents in the surface layer were variable and perhaps partly easterly.

Temperature--Temperature sections from the BT data appear in figures 5, 8, 12, and 16. As mentioned above, in order to reveal detail these sections were constructed with greater vertical exaggeration than those of the other variables. The BT casts from which the Smith sections were drawn were taken every 10 miles between stations, and every 30 miles along  $155^\circ$  W. longitude north of  $8^\circ$  N. latitude. Two casts were taken at each station; the one nearest in time to the hydrographic cast was plotted in each case. The Manning sections are drawn from casts made on the fishing stations only. The Manning fished one station per day; the date of the first station on each line is given in the figure caption.

On each section the downward slope of the thermocline away from the Equator to north and south (as distinguished from the pronounced arching of the shallower isotherms at the Equator) is evidence of the distribution of mass associated with the South Equatorial Current, and the northward rise starting a few degrees north of the Equator is associated with the easterly flow of the Equatorial Countercurrent. Only the Smith section along  $155^\circ$  W. longitude extends beyond this into the North Equatorial Current, indicated by a second northward deepening. The southward rise of the isotherms at the southern end of the  $180^\circ$  longitude line is reflected in the weakening of the westerly flow indicated here by the computed dynamic heights of isobaric surfaces. These gross "topographic" features, associated primarily with zonal currents, are reflected in the distributions of each of the variables. In the surface layer, lower temperatures at the Equator are evidence of the addition of water from somewhat greater depths.

As mentioned above, a comparison of the Smith and Manning sections indicates the possibility of quite considerable changes in detail in a relatively short time, although the basic features remain distinct.

Surface temperatures are indicated at the top of each temperature section. These are often influenced by shallow diurnal effects, as at  $3^{\circ}15'N$ . latitude,  $180^{\circ}$  longitude (fig. 8); no attempt was made to include these temporary variations in the vertical temperature sections.

Several of the details of the temperature field, such as the reduction of the vertical temperature gradient at the Equator and the presence of stable inversions in the thermocline near the Equator, are described in reports of this series (Cromwell 1954, Austin MS.). Both of these features are seen on each of the Smith cruise 14 temperature sections. A detail not so far described is the persistent, relatively "sharp" bottom of the main thermocline at about  $2^{\circ}$ - $3^{\circ}$  N. latitude. Figure 17 presents BT traces taken near these latitudes on various longitudes during several cruises. The traces best illustrating the phenomenon were chosen from a meridional series in each case, demonstrating a remarkable consistency in position; it has moreover never been completely absent. Figure 18 gives the detailed temperature structure on the oblique section marked on figure 2. The most evident "sharp" bottom of the thermocline is seen at  $2^{\circ}06'N$ . latitude,  $175^{\circ}04'W$ . longitude; this particular trace is second from the left in figure 17.

Sigma-t--The distribution of sigma-t is shown in figures 6, 9, and 13. These figures are closely associated with, and share most of the details of, the temperature sections (see procedures). For an exception to this rather general rule, the surface layer decrease in density at the southern end of the  $180^{\circ}$  longitude line is largely associated with a decrease in salinity. The expected slight east to west thickening of the light surface layer may be seen in a comparison of the sections.

There is a marked meridional change in the character of the water just beneath the main thermocline in approximately the  $2^{\circ}$ - $3^{\circ}$  N. latitude region discussed above; this feature is reflected in the sharp southerly increase in depth of the sigma-t isopleths 26.6 to 27.0 in this area. The effect of this distribution of density is evident in the plot of dynamic heights of isobaric surfaces, but at these latitudes the interpretation is extremely uncertain. Barnes et al. (1948, p. 872) describe what seems to be a similar case in the Marshall Islands area, with regard to a dip in the  $10^{\circ}C$ . isotherm.

Salinity--The vertical sections of the field of salinity are shown in figures 7, 10, and 14. The major features of the distribution are as described previously for the central Pacific (Cromwell 1951, 1953, 1954; Austin 1954; Montgomery 1954; Mao and Yoshida 1953). The similarity from section to section of Smith cruise 14 is self-evident.

The detailed vertical distribution of salinity in the region of  $2^{\circ}$ - $3^{\circ}$  N. latitude is of interest and is not readily evident from the sections. Figure 1, illustrating the method of representing the oceanographic stations is taken from Smith cruise 14, station 27 at  $2^{\circ}07'N$ . latitude,  $179^{\circ}57'W$ . longitude and shows this distribution. The sharp bottom of the thermocline seems to be a boundary between overlying water associated with a salinity minimum extending from the north, in the thermocline, and deeper water with a temperature-salinity relation identical with that of water to the south. The salinity decreases downward through the thermocline, increases sharply across the boundary, then decreases gradually again below; the relative maximum and minimum values lie close together vertically. With the isopleth values used, this feature is most evident on the  $180^{\circ}$  longitude section. The increase in salinity across the boundary is often accompanied by a stable temperature inversion. Farther to the north the vertical transition below the salinity minimum is more gradual; toward the Equator the salinity minimum disappears into the very salty water extending into the area from the south.

Phosphate phosphorous--The vertical sections of inorganic phosphate for longitudes  $180^{\circ}$  and  $169^{\circ}$  W. appear in figures 11 and 15. On the  $155^{\circ}$  W. longitude line the colorimeter

broke down after the first five stations; data for these are tabulated but no figure was drawn. A relatively higher concentration of phosphate about the Equator in the surface layer, seen on the two sections included, is evidence of enrichment from below.

#### Acknowledgements

Many more persons than can be mentioned here share the credit for the successful completion of Smith cruise 14, and for the publication of this report. The field party personnel during the cruise comprised: Garth I. Murphy (field party chief), E. D. Stroup, H. Yuen, T. Hida, and T. Roseberry. Special thanks must go to Captain Ralph Johnson and the crew of the Hugh M. Smith for the utmost cooperation with the scientific field party. Ashore, Mary Lynne Godfrey was largely responsible for the processing of the data. Tamotsu Nakata drafted the figures.

T. S. Austin, T. Cromwell, and Dr. R. B. Montgomery gave invaluable assistance and encouragement in the many stages of preparation of the data, and during the writing of the report.

## LITERATURE CITED

AUSTIN, T. S.

1954. Mid-Pacific oceanography III, transequatorial waters, August-October 1951. U. S. Fish and Wildlife Serv., Spec. Sci. Rep.: Fish. No. 131. (In press).

MS. Mid-Pacific oceanography V, transequatorial waters, May-June 1952, August 1952.

BARNES, C. A., D. R. BUMPUS and J. LYMAN

1948. Ocean circulation in the Marshall islands area. Trans. Amer. Geophys. Union, Vol. 29, No. 6, pp. 871-876.

CROMWELL, T.

1951. Mid-Pacific oceanography. January-March 1950. U. S. Fish and Wildlife Serv., Spec. Sci. Rep.: Fish. No. 54, 9 pp.

1953. Circulation in a meridional plane in the central equatorial Pacific, Jour. of Mar. Res., Vol. 12, No. 2, pp. 196-213.

1954. Mid-Pacific oceanography II, transequatorial waters, June-August 1950, January-March 1951. U. S. Fish and Wildlife Serv., Spec. Sci. Rep.: Fish. No. 131. (In press).

MAO, HAN-LEE and K. YOSHIDA

1953. Physical oceanography in the Marshall islands area. Univ. of Calif., Scripps Inst. of Ocean., Ref. 53-27, April 15, 1953.

MONTGOMERY, R. B.

1954. Analysis of a Hugh M. Smith oceanographic section from Honolulu southward across the Equator. Accepted for publication in the Jour. of Mar. Res., Vol. 13, No. 1.

MURPHY, G. I. and R. S. SHOMURA

1953. Longline fishing for deep-swimming tunas in the central Pacific, January-June 1952. U. S. Fish and Wildlife Serv., Spec. Sci. Rep.: Fish. No. 108, 32 pp.

## Figures

Frontispiece: Hydrographic platform and winch, Hugh M. Smith cruise 14. Photo by G. I. Murphy.

1. Example of station data representation.
2. Station positions.
3. Dynamic topography, 155° W.
4. Geostrophic currents, 155° W.
5. Vertical section of temperature, 155° W.
6. Vertical section of sigma-t, 155° W.
7. Vertical section of salinity, 155° W.
8. Vertical section of temperature, 180°.
9. Vertical section of sigma-t, 180°.
10. Vertical section of salinity, 180°.
11. Vertical section of phosphate, 180°.
12. Vertical section of temperature, 169° W.
13. Vertical section of sigma-t, 169° W.
14. Vertical section of salinity, 169° W.
15. Vertical section of phosphate, 169° W.
16. Vertical sections of temperature, John R. Manning cruise 11.
17. BT traces showing "sharp" thermocline bottom.
18. BT section showing "sharp" thermocline bottom.

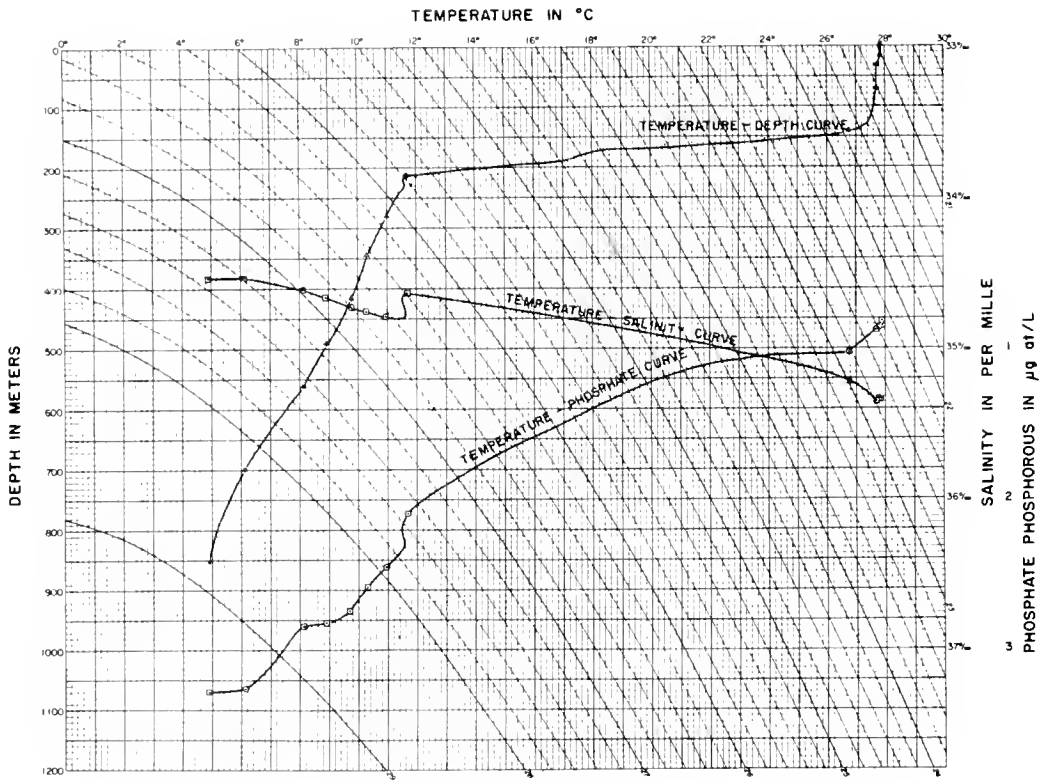

Fig. 1--(Revised from Cromwell 1954). Example of graph used to present temperature, salinity, and phosphate data for each station. Points under inverted V represent reversing thermometer temperatures; plain points are taken from the station BT trace (both plotted against depth). Points in a square represent salinity, and those in a circle phosphate, both plotted against temperature. Smith cruise 14, station 27,  $2^{\circ}07'N$ . latitude,  $179^{\circ}57'W$ . longitude, February 19, 1952, 1336 GCT.

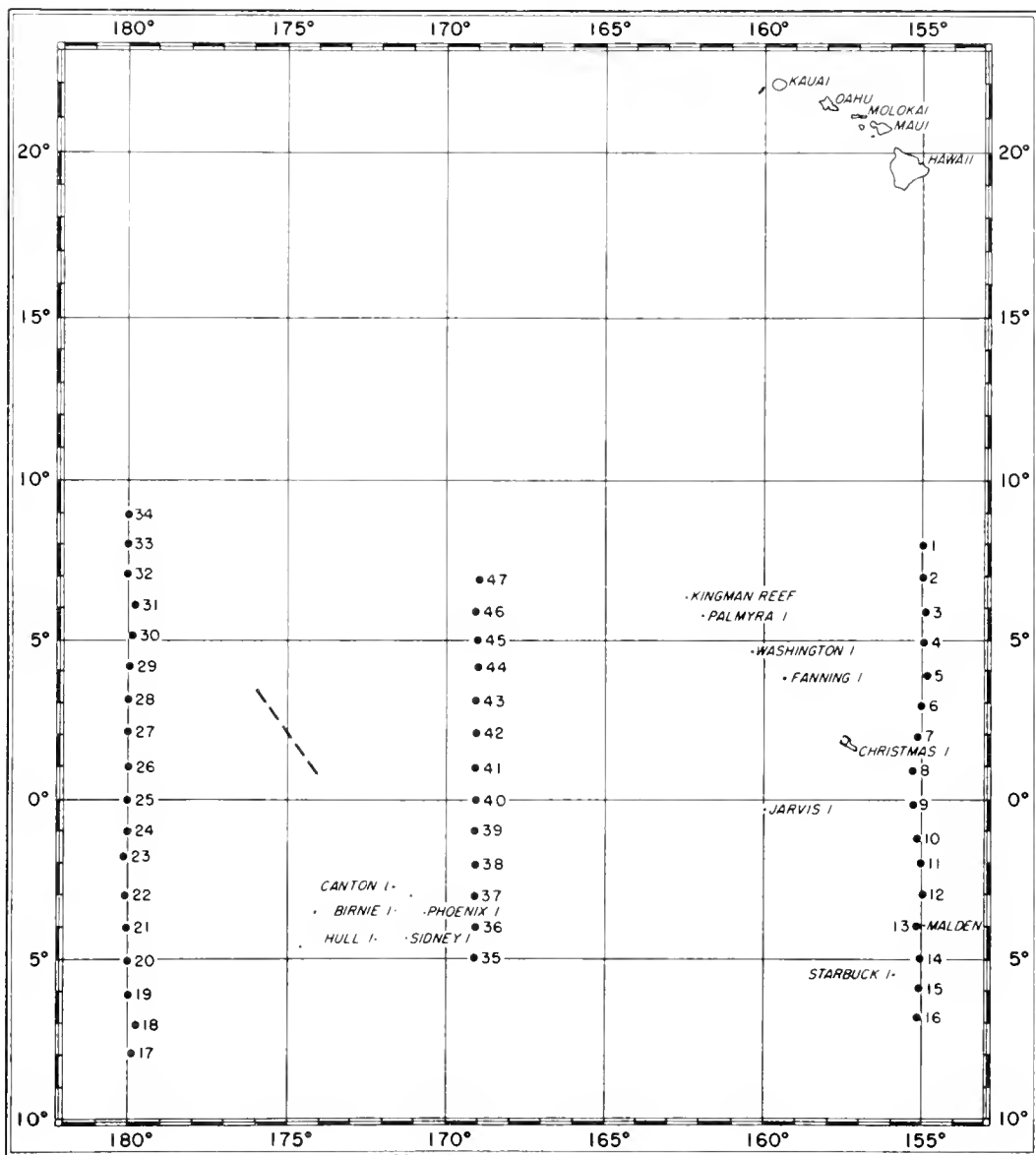

Fig. 2--Hydrographic station positions. Hugh M. Smith cruise 14, January-March 1952. Location of temperature section in figure 18 indicated by dashed line.

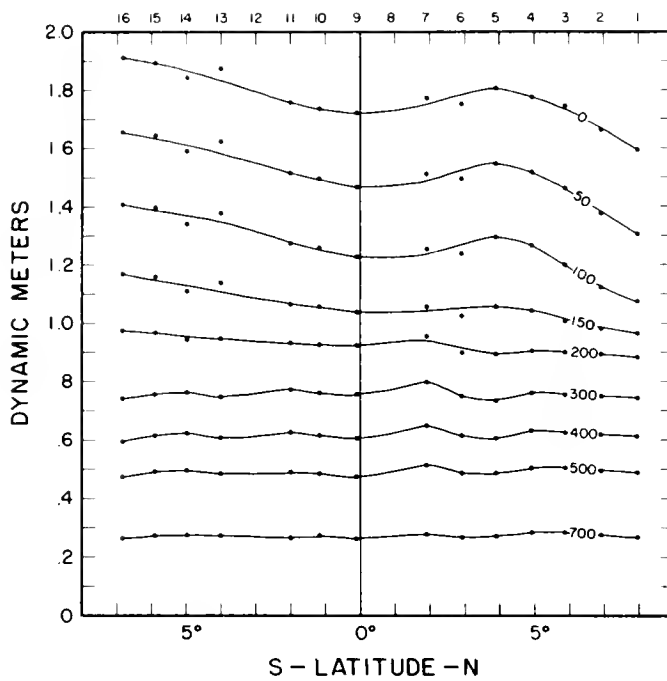

Fig. 3--Smoothed anomaly of topographies of isobaric surfaces relative to the 1,000-decibar surface. Hugh M. Smith cruise 14, stations 1-16,  $155^{\circ}$  W. longitude,  $8^{\circ}$  N. to  $7^{\circ}$  S. latitude, January-February 1952. Points represent computed values.

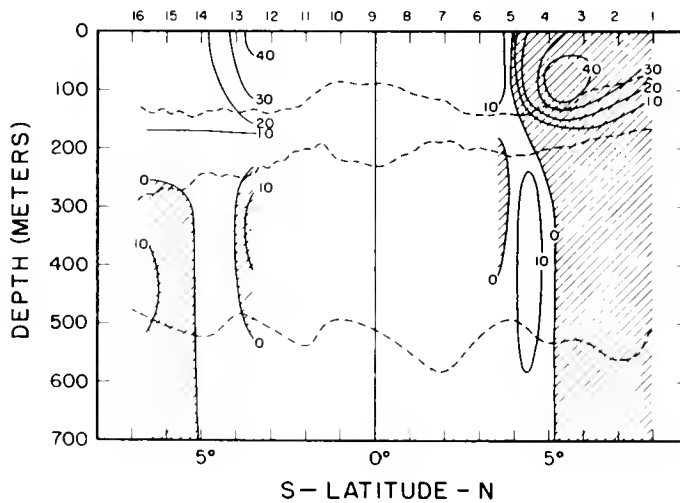

Fig. 4--Zonal component of geostrophic currents in centimeters per second. Hugh M. Smith cruise 14, stations 1-16,  $155^{\circ}$  W. longitude,  $8^{\circ}$  N. to  $7^{\circ}$  S. latitude, January-February 1952. Plotting interval 10 cm/sec. East currents hatched. Isopleths of  $\sigma\text{-}t = 23.2, 26.4$  and  $27.0$  entered as dashed lines.



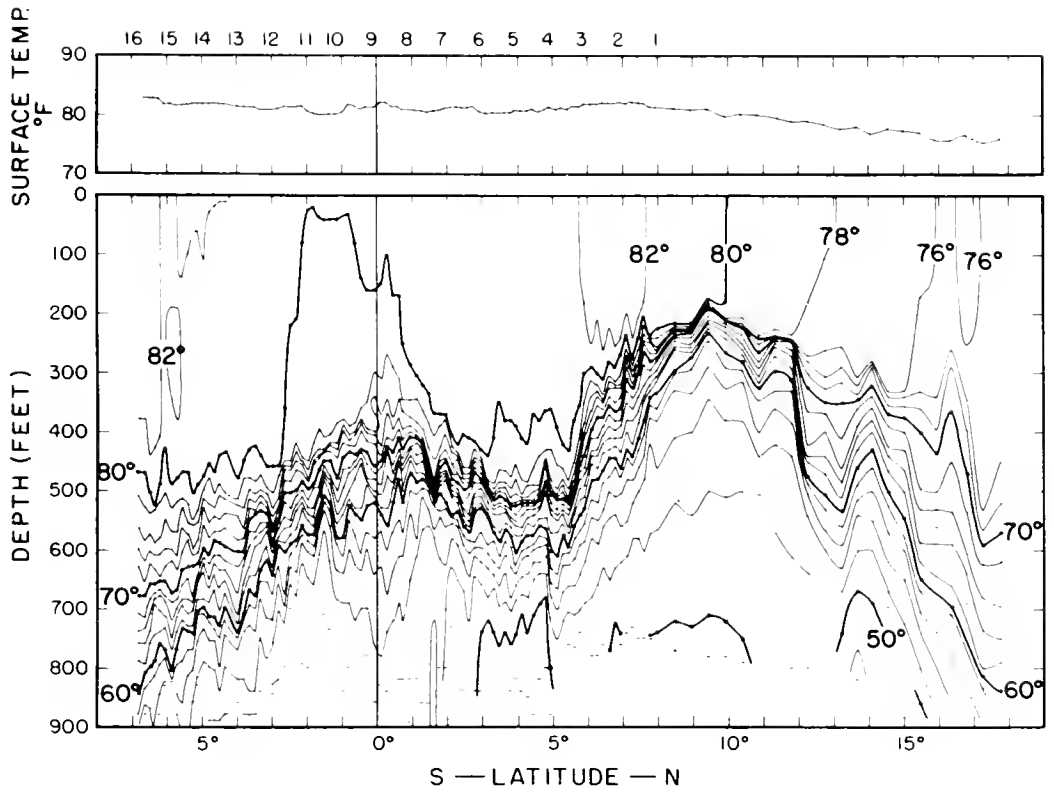

Fig. 5--Upper: surface temperatures by bucket thermometer in degrees F., measured with each BT cast. Lower: temperatures from BT data in degrees F. Hugh M. Smith cruise 14, stations 1-16, 155° W. longitude, 8° N. to 7° S. latitude, January-February 1952. Plotting interval 2° F. Horizontal dashes indicate depths of observations less than 900 feet.

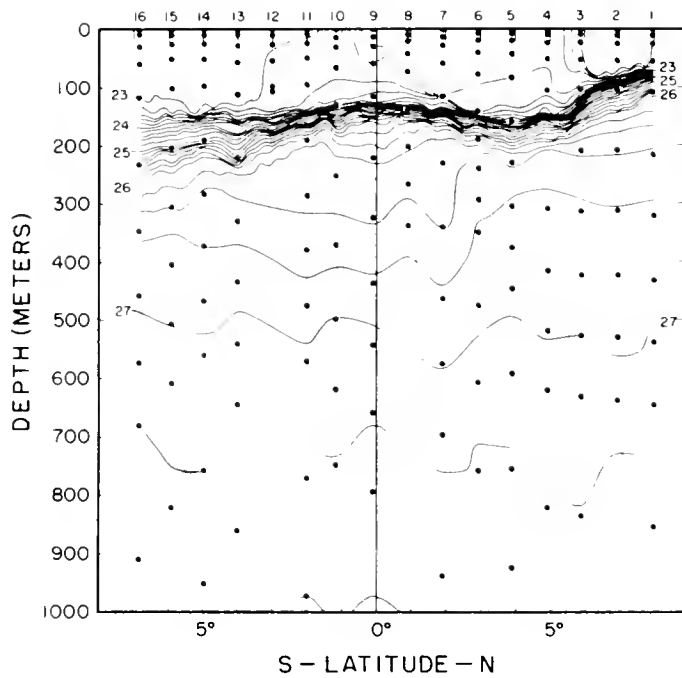

Fig. 6--Sigma-t in grams per liter. Hugh M. Smith cruise 14, stations 1-16, 155° W. longitude, 8° N. to 7° S. latitude, January-February 1952. Plotting interval 0.2 g/l.

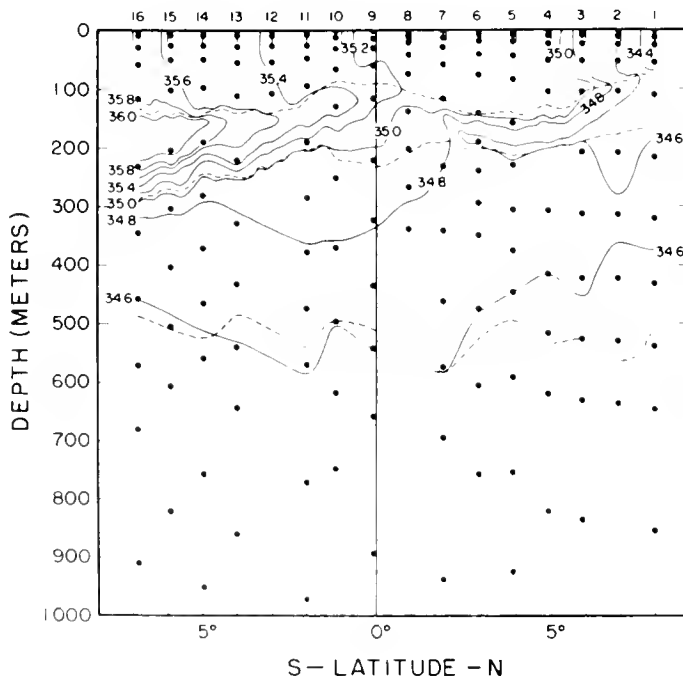

Fig. 7--Salinity in per mille. Hugh M. Smith cruise 14, stations 1-16, 155° W. longitude, 8° N. to 7° S. latitude, January-February 1952. Plotting interval 0.2 ‰. Isopleths of sigma-t = 23.2, 26.4 and 27.0 entered as dashed lines.

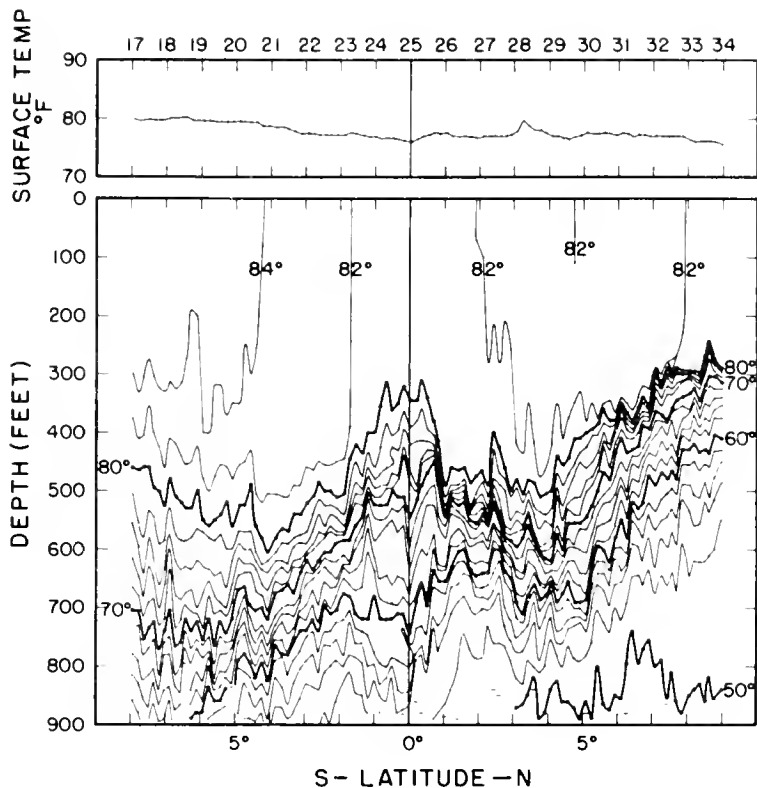

Fig. 8--Upper: surface temperatures by bucket thermometer in degrees F., measured with each BT cast. Lower: temperatures from BT data in degrees F. Hugh M. Smith cruise 14, stations 17-34, 180° longitude, 8° S. to 9° N. latitude, February 1952. Plotting interval 2° F. Horizontal dashes indicate depths of observations less than 900 feet.

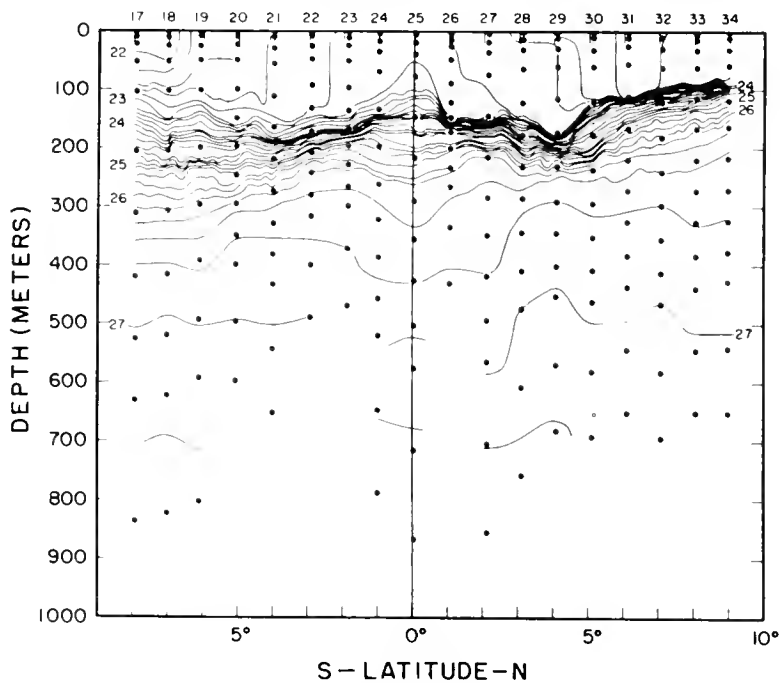

Fig. 9--Sigma-t in grams per liter. Hugh M. Smith cruise 14, stations 17-34, 180° longitude, 8° S. to 9° N. latitude, February 1952. Plotting interval 0.2 g/l.

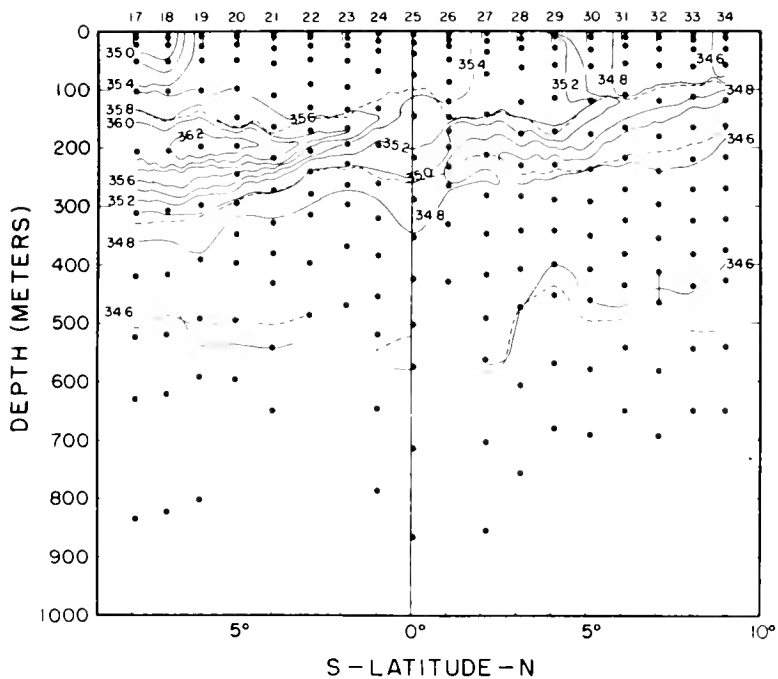

Fig. 10--Salinity in per mille. Hugh M. Smith cruise 14, stations 17-34,  $180^{\circ}$  longitude,  $8^{\circ}$  S. to  $9^{\circ}$  N. latitude, February 1952. Plotting interval  $0.2 \text{ }^{\circ}/\text{oo}$ . Isopleths of  $\sigma\text{-}t = 23.2, 26.4$  and  $27.0$  entered as dashed lines. Solid vertical line indicates vertically isohaline water at the salinity of the intersecting isohaline.

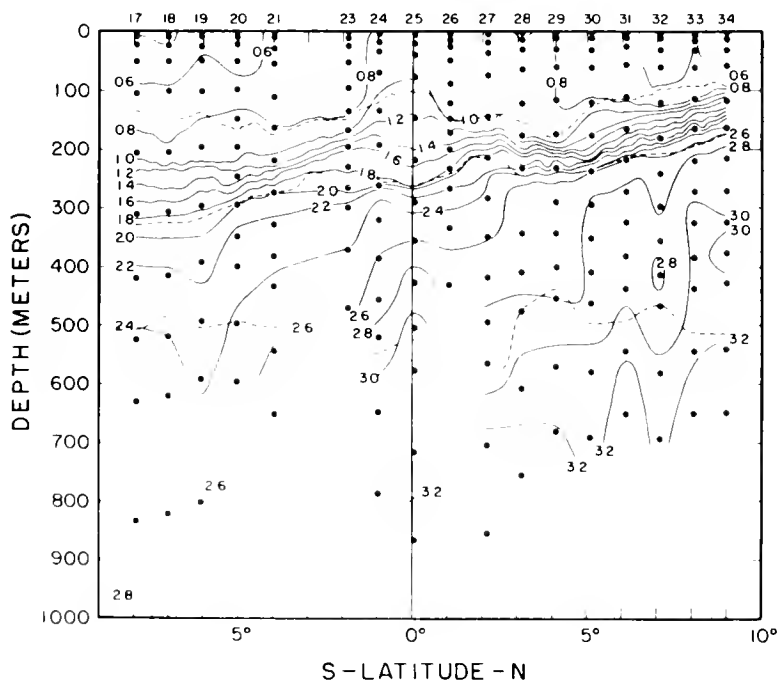

Fig. 11--Phosphate phosphorous in microgram-atoms per liter. Hugh M. Smith cruise 14, stations 17-34,  $180^{\circ}$  longitude,  $8^{\circ}$  S. to  $9^{\circ}$  N. latitude, February 1952. Plotting interval  $0.2 \text{ } \mu\text{g-at}/\text{l}$ . Isopleths of  $\sigma\text{-}t = 23.2, 26.4$  and  $27.0$  entered as dashed lines.

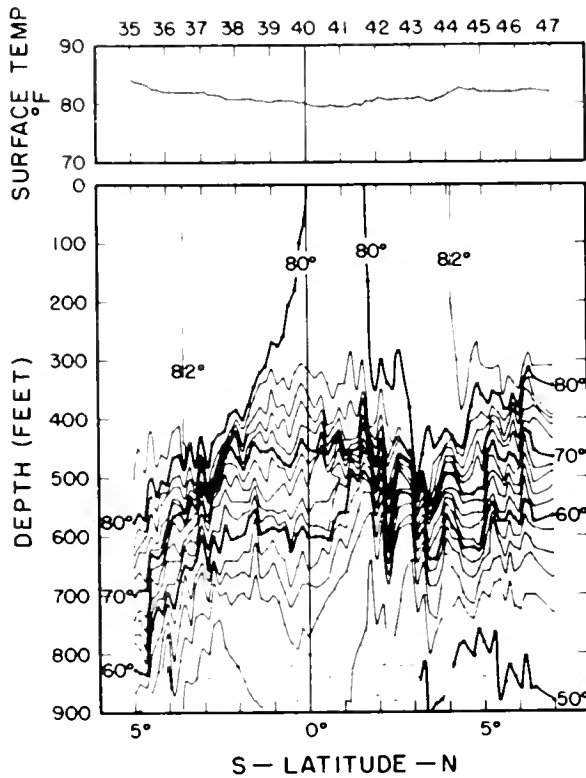

Fig. 12--Upper: surface temperatures by bucket thermometer in degrees F., measured with each BT cast. Lower: temperatures from BT data in degrees F. Hugh M. Smith cruise 14, stations 35-47, 169° W. longitude, 5° S. to 7° N. latitude, March 1952. Plotting interval 2° F. Horizontal dashes indicate depths of observations less than 900 feet.

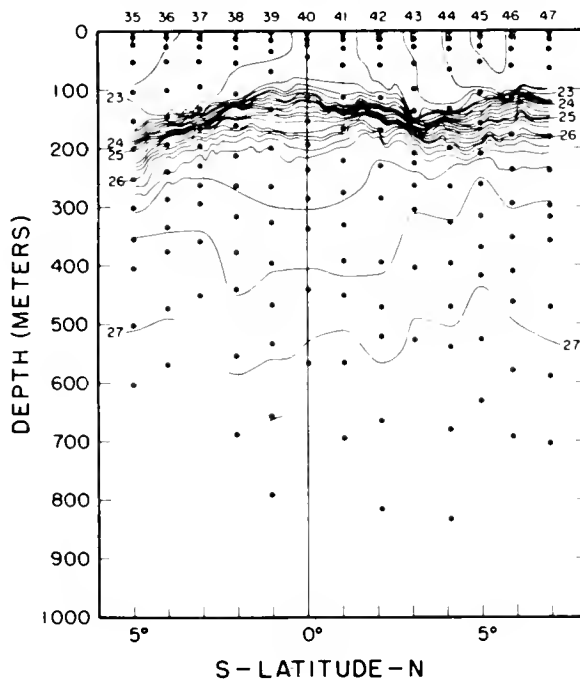

Fig. 13--Sigma-t in grams per liter. Hugh M. Smith cruise 14, stations 35-47, 169° W. longitude, 5° S. to 7° N. latitude, March 1952. Plotting interval 0.2 g/l.

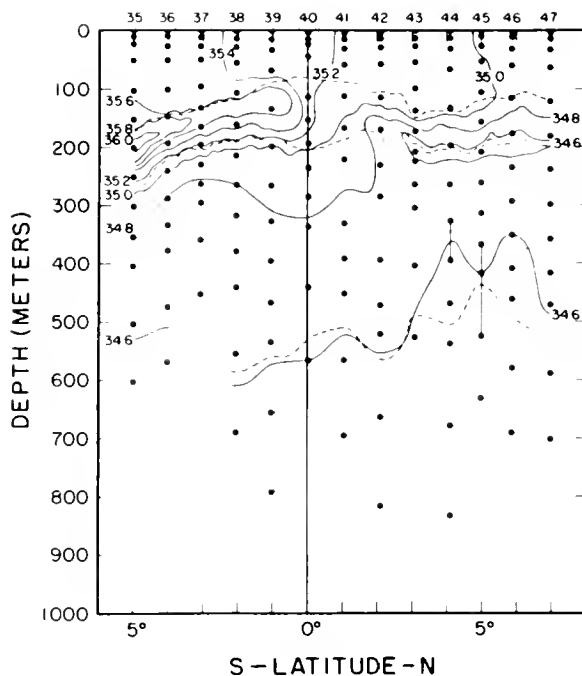

Fig. 14--Salinity in per mille. Hugh M. Smith cruise 14, stations 35-47, 169° W. longitude, 5° S. to 7° N. latitude, March 1952. Plotting interval 0.2 ‰. Isopleths of  $\sigma\text{-}t = 23.2, 26.4$  and  $27.0$  entered as dashed lines. Solid vertical line indicates vertically isohaline water at the salinity of the intersecting isohaline.

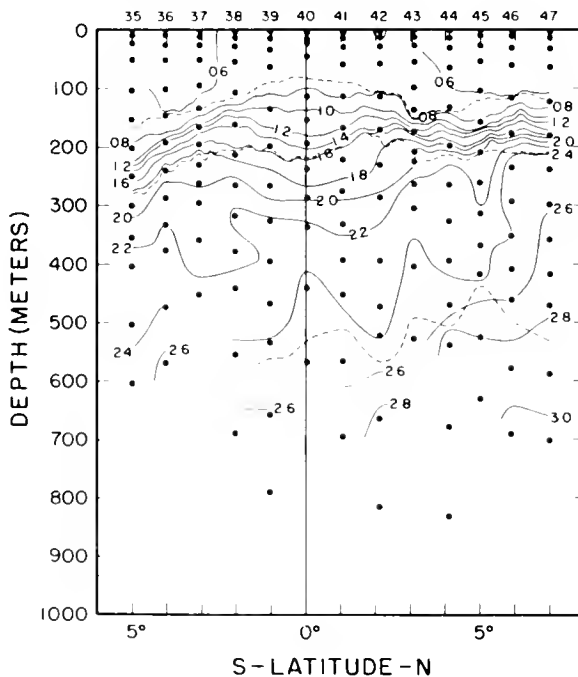

Fig. 15--Phosphate phosphorous in microgram-atoms per liter. Hugh M. Smith cruise 14, stations 35-47, 169° W. longitude, 5° S. to 7° N. latitude, March 1952. Plotting interval  $0.2 \mu\text{g-at/l}$ . Isopleths of  $\sigma\text{-}t = 23.2, 26.4,$  and  $27.0$  entered as dashed lines.

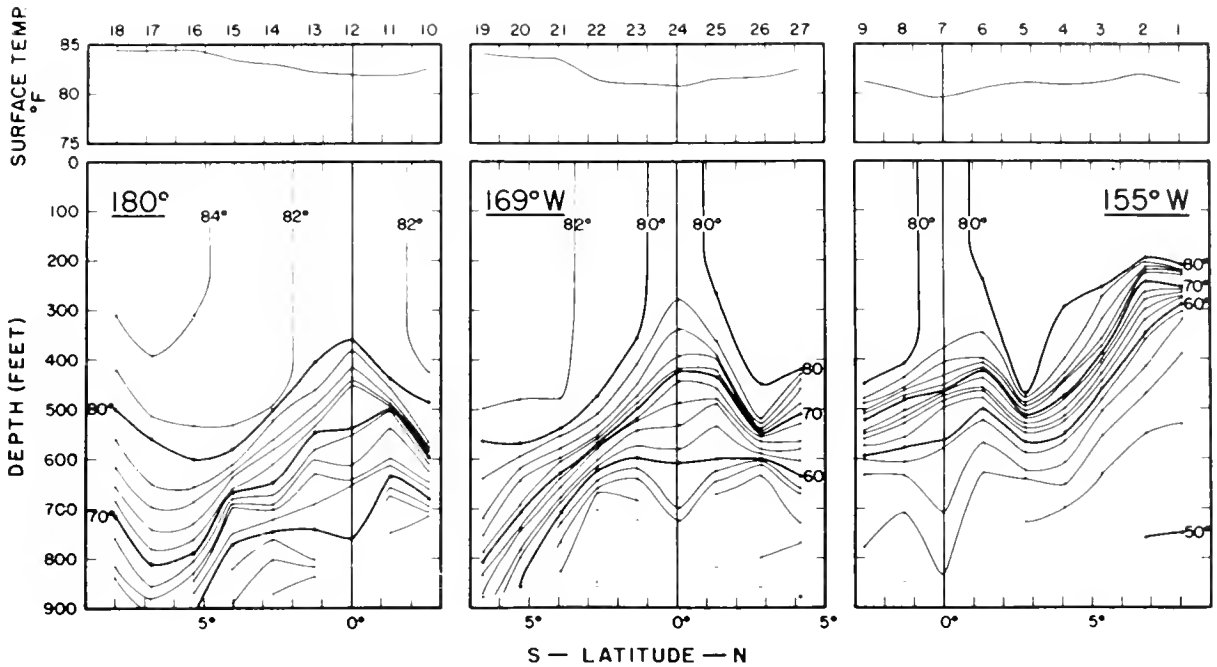

Fig. 16--Upper: surface temperatures by bucket thermometer in degrees F., measured with each BT cast. Lower: temperatures from BT data in degrees F. John R. Manning cruise 11. Right: stations 1 (January 29) - 9, 155° W. longitude, 8° N. to 2°40'S. latitude, January-February 1952. Center: stations 19 (March 4) - 27, 169° W. longitude, 6°40'S. to 4°10'N. latitude, March 1952. Left: stations 10 (February 16) - 18, 180° longitude, 2°35'N. to 8° S. latitude, February 1952. Plotting interval 2° F. Horizontal dashes indicate depths of observations less than 900 feet.

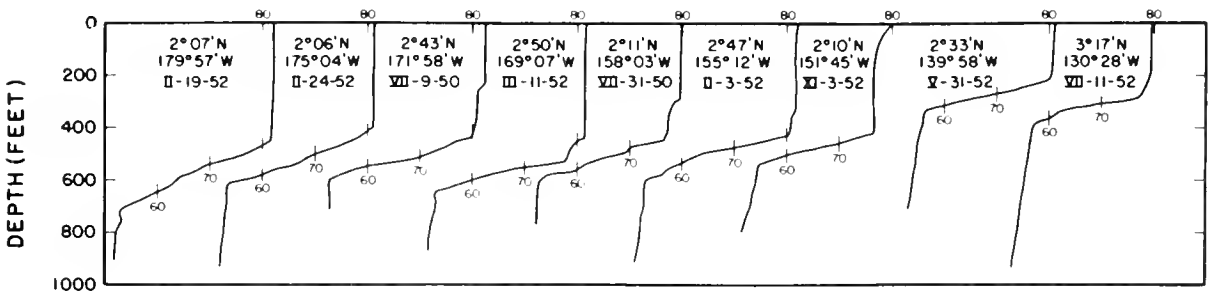

Fig. 17--BT traces illustrating the "sharp" thermocline bottom, 2°-3° N. latitude. Temperatures in degrees F., depths in feet. Position and date of each trace indicated.

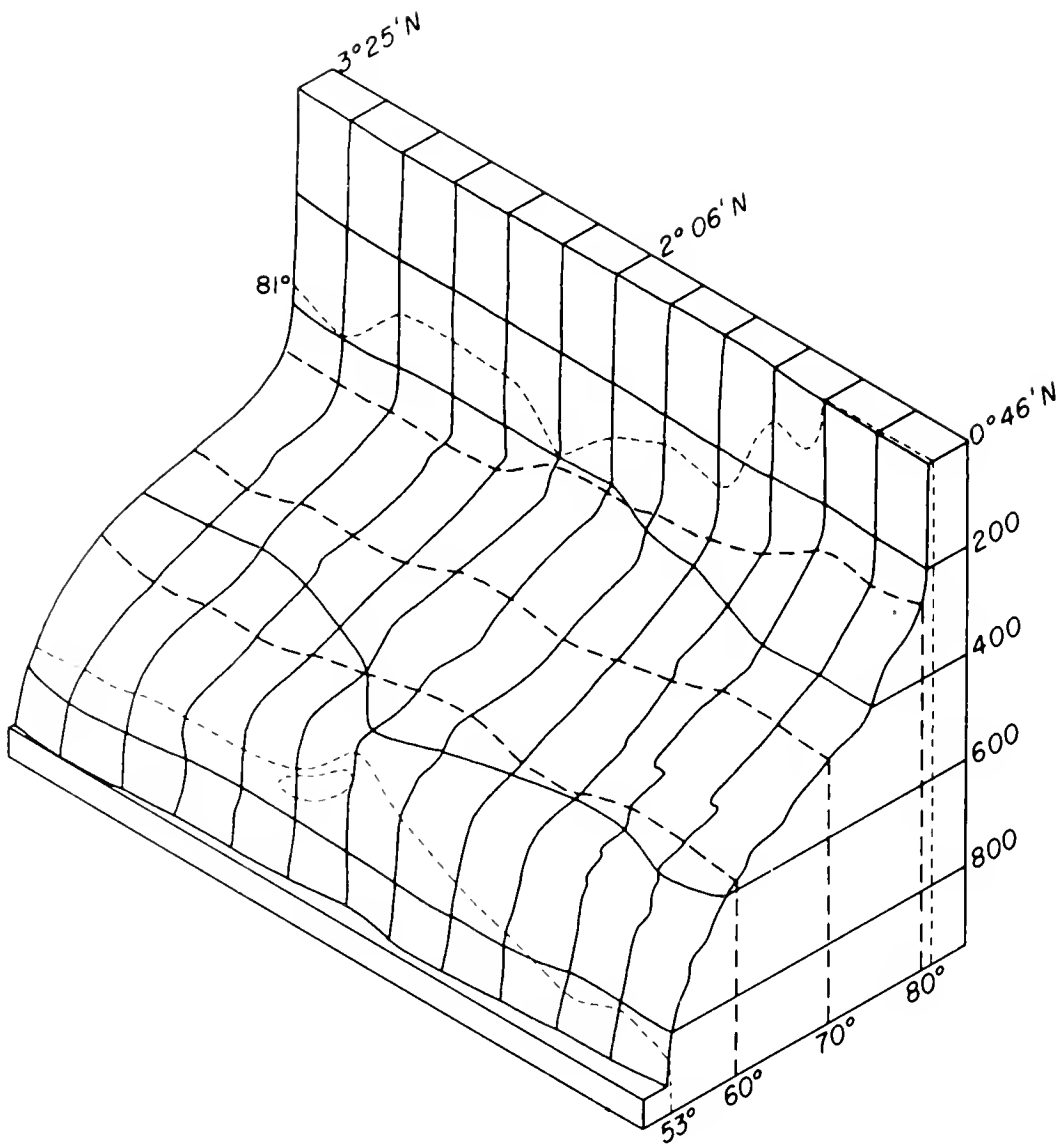

Fig. 18--Isometric block diagram presenting BT traces,  $3^{\circ}25'N$ . latitude,  $175^{\circ}57'W$ . longitude to  $0^{\circ}46'N$ . latitude,  $174^{\circ}05'W$ . longitude, Hugh M. Smith cruise 14. Depth in feet, temperature in degrees F.



## NOTES ON THE TABULATED DATA

In every case, any variation from the standard 13-bottle cast has been explained in a footnote.

Where more than one cast was made on a station, they are divided in the observed data by a horizontal line. The later casts are the deeper ones except on station 34, where a single bottle was recast.

Where the corrected paired protected thermometer readings differed by more than  $0.05^{\circ}$  C., the depth and salinity are repeated, and both temperature values are carried. Sigma-t values calculated using each temperature are tabulated.

Where the duplicate determinations of inorganic phosphate differ in extinction value by more than 0.01 (approximately  $0.05 \mu\text{g at/l}$ ), the depth is repeated, and both phosphate values are carried.

Weather is recorded in the ww (present weather) code given in the U. S. Weather Bureau Circular M, eighth edition, Manual of Marine Meteorological Observations. Cloud coverage is given in tenths of sky.

Wind velocity was measured with an anemometer 30 meters above the sea surface. The direction (given to the nearest  $10^{\circ}$ ) is that from which the wind was blowing, measured clockwise through  $360^{\circ}$  from north.

No phosphate determinations were made from station 6 to station 16, and no data interpolated at standard depths for dynamic computations after station 19 (see text).

## STATION 1

M/V Hugh M. Smith: Cruise 14, 7°57'N, 154°57'W, January 27, 1952. Messenger time: 2103 GCT. Weather: 03, cloud coverage 7. Wind: 070°, 24 kt. Sea: 5-8 ft. Wire angle: 12°

## OBSERVED

DEPTH (m)	T (°C)	S (°/oo)	$\sigma_t$ (g/l)	O <sub>2</sub> (ml/l)	PO <sub>4</sub> -P ( $\mu$ g at/l)
00	27.43	34.18	21.98		0.39
11	27.44	34.18	21.98		0.45
26	27.40	34.20	22.01		0.45
55	27.17	34.29	22.15		0.61
109	13.35	34.44	25.91		2.31
215	10.25	34.66	26.66		2.34
321	09.16	34.63	26.82		2.48
432	08.39	34.56	26.89		2.63
538	07.35	34.53	27.02		2.85
646	06.45	34.47	27.10		3.02
853	05.04	34.52	27.31		3.24
1064	04.14	34.51	27.40		3.05
1266	03.54	34.54	27.49		2.93

## INTERPOLATED AND CALCULATED

DEPTH (m)	T (°C)	S (°/oo)	$\sigma_t$ (gm/l)	$\Delta D$ (dyn. m)	$\Delta D 1000 - \Delta D$ (dyn. m)
00	27.43	34.18	21.98	0.000	1.595
10	27.42	34.18	21.99	0.058	1.537
20	27.42	34.19	22.00	0.117	1.478
30	27.40	34.20	22.01	0.175	1.420
50	27.20	34.27	22.13	0.291	1.304
75	25.10	34.51	22.96	0.424	1.171
100	15.58	34.46	25.45	0.518	1.077
150	11.94	34.49	26.23	0.629	0.966
200	10.61	34.63	26.57	0.713	0.882
250	09.79	34.66	26.74	0.786	0.810
300	09.35	34.65	26.81	0.853	0.742
400	08.62	34.58	26.87	0.982	0.613
500	07.71	34.54	26.98	1.105	0.490
600	06.87	34.49	27.06	1.220	0.376
700	06.03	34.48	27.16	1.326	0.269
800	05.33	34.51	27.27	1.423	0.173
1000	04.41	34.52	27.38	1.595	0.000

## STATION 2

M/V Hugh M. Smith: Cruise 14, 6°55'N, 154°57'W, January 28, 1952. Messenger time: 0647 GCT. Weather: 80, cloud coverage 10. Wind: 030°, 22 kt. Sea: 5-8 ft. Wire angle: 17°

## OBSERVED

DEPTH (m)	T (°C)	S (°/oo)	$\sigma_t$ (g/l)	O <sub>2</sub> (ml/l)	PO <sub>4</sub> -P ( $\mu$ g at/l)
00	27.93	34.65	22.18		0.34
11	27.96	34.60	22.13		0.32
11					0.30
25	27.94	34.60	22.13		0.36
53	27.96	34.59	22.12		0.47
105	20.08	34.74	24.56		0.72
209	10.24	34.55	26.58		2.32
313	09.18	34.62	26.81		2.56
423	00.34	34.57	26.91		2.79
423					2.86
530	07.63	34.50	26.96		2.97
637	06.79	34.52	27.09		3.08
1052	04.38	34.50	27.37		3.24
<u>1/</u>					

## INTERPOLATED AND CALCULATED

DEPTH (m)	T (°C)	S (°/oo)	$\sigma_t$ (gm/l)	$\Delta D$ (dyn. m)	$\Delta D 1000 - \Delta D$ (dyn. m)
00	27.93	34.65	22.18	0.000	1.663
10	27.95	34.60	22.13	0.057	1.606
20	27.95	34.60	22.13	0.114	1.549
30	27.95	34.60	22.13	0.171	1.492
50	27.96	34.59	22.12	0.286	1.378
75	27.61	34.68	22.30	0.427	1.236
100	21.00	34.77	24.34	0.542	1.121
150	12.70	34.53	26.11	0.683	0.981
200	10.38	34.55	26.55	0.770	0.893
250	09.78	34.58	26.68	0.844	0.819
300	09.29	34.61	26.79	0.913	0.750
400	08.50	34.59	26.89	1.043	0.620
500	07.89	34.52	26.93	1.166	0.497
600	07.06	34.51	27.05	1.283	0.380
700	06.24	34.52	27.16	1.390	0.273
800	05.50	34.53	27.27	1.487	0.176
1000	04.48	34.50	27.36	1.663	0.000

1/ Two bottles pretripped, but were not recast.

## STATION 3

M/V Hugh M. Smith: Cruise 14, 5°53'N, 154°55'W, January 28, 1952. Messenger time: 1708 GCT. Weather: 02, cloud coverage 1. Wind: 040°, 22 kt. Sea: 8-12 ft. Wire angle: 19°

## OBSERVED

DEPTH (m)	T (°C)	S (‰)	$\sigma_t$ (g/l)	O <sub>2</sub> (ml/l)	PO <sub>4</sub> -P ( $\mu\text{g at/l}$ )
01	27.84	34.65	22.20		0.40
09	27.87	34.66	22.20		0.45
09					0.37
24	27.82	34.63	22.20		0.39
53	27.73	34.74	22.31		0.40
105	26.16	35.09	23.07		0.70
209	10.66	34.62	26.56		2.43
313	09.16	34.64	26.83		2.49
423	08.45	34.61	26.92		2.66
527	07.65	34.55	26.99		2.94
632	06.85	34.56	27.11		2.98
835	05.92	34.52	27.20		3.10
1039	04.40	34.54	27.40		3.18
1237	03.74	34.56	27.48		3.07
1237					3.21

## INTERPOLATED AND CALCULATED

DEPTH (m)	T (°C)	S (‰)	$\sigma_t$ (gm/l)	$\Delta D$ (dyn. m)	$\Delta D 1000 - \Delta D$ (dyn. m)
00	27.84	34.65	22.20	0.000	1.744
10	27.87	34.66	22.20	0.056	1.688
20	27.84	34.64	22.20	0.113	1.631
30	27.80	34.65	22.22	0.169	1.575
50	27.76	34.73	22.29	0.281	1.463
75	27.22	34.95	22.63	0.417	1.327
100	26.40	35.08	22.99	0.544	1.200
150	17.00	34.73	25.32	0.736	1.008
200	11.00	34.62	26.50	0.844	0.900
250	10.01	34.63	26.68	0.919	0.825
300	09.30	34.64	26.81	0.988	0.756
400	08.58	34.62	26.91	1.116	0.628
500	07.92	34.57	26.97	1.237	0.507
600	07.05	34.56	27.09	1.351	0.393
700	06.60	34.55	27.14	1.457	0.287
800	06.15	34.53	27.19	1.560	0.184
1000	04.67	34.54	27.37	1.744	0.000

## STATION 4

M/V Hugh M. Smith: Cruise 14, 4°55'N, 154°51'W, January 29, 1952. Messenger time: 0227 GCT. Weather: 02, cloud coverage 1. Wind: 060°, 22 kt. Sea: 8-12 ft. Wire angle: 15°

## OBSERVED

DEPTH (m)	T (°C)	S (‰)	$\sigma_t$ (g/l)	O <sub>2</sub> (ml/l)	PO <sub>4</sub> -P ( $\mu\text{g at/l}$ )
00	27.25	35.08	22.72		0.77
10	27.26	35.07	22.71		0.71
10					0.63
24	27.17	35.04	22.71		0.78
24					0.64
52	27.02	35.04	22.76		0.60
105	26.71	35.16	22.95		0.79
207 <sup>1/</sup>	10.84				
309	09.26	34.65	26.92		2.29
309					2.52
416	08.70	34.60	26.87		2.71
518	07.99	34.58	26.97		2.91
620	07.14	34.57	27.08		3.13
821 <sup>2/</sup>	05.79	34.52	27.22		2.84
821	05.82	34.52	27.22		3.14
1027	04.60	34.54	27.38		3.27
1027	04.60	34.54	27.38		2.91
1225	03.84	34.55	27.46		2.52
1225					2.20

## INTERPOLATED AND CALCULATED

DEPTH (m)	T (°C)	S (‰)	$\sigma_t$ (gm/l)	$\Delta D$ (dyn. m)	$\Delta D 1000 - \Delta D$ (dyn. m)
00	27.25	35.08	22.72	0.000	1.775
10	27.26	35.07	22.71	0.051	1.723
20	27.20	35.04	22.71	0.103	1.672
30	27.10	35.04	22.74	0.155	1.620
50	27.02	35.04	22.76	0.257	1.518
75	26.89	35.14	22.88	0.384	1.391
100	26.77	35.16	22.94	0.509	1.266
150	22.00	34.94	24.19	0.729	1.046
200	11.90	34.62	26.33	0.869	0.906
250	09.64	34.65	26.76	0.946	0.829
300	09.30	34.65	26.81	1.013	0.762
400	08.79	34.61	26.87	1.142	0.633
500	08.10	34.58	26.95	1.267	0.508
600	07.28	34.57	27.06	1.383	0.392
700	06.57	34.54	27.14	1.491	0.284
800	05.90	34.52	27.21	1.592	0.183
1000	04.74	34.53	27.35	1.775	0.000

<sup>1/</sup> Phosphate and salinity values are not good; temperature seems all right.

<sup>2/</sup> Both the temperature and phosphate duplicates were out of tolerance for this observation.

## STATION 5

M/V Hugh M. Smith: Cruise 14, 3°54'N, 154°51'W, January 29, 1952. Messenger time: 1128 GCT. Weather: 02, cloud coverage 1. Wind: 040°, 15 kt. Sea: 5-8 ft. Wire angle: 38°

## OBSERVED

DEPTH (m)	T (°C)	S (‰)	$\sigma_t$ (g/l)	O <sub>2</sub> (ml/l)	PO <sub>4</sub> -P ( $\mu\text{g at/l}$ )
00	27.17	35.14	22.79		0.72
08	27.20	35.17	22.80		0.73
20	27.18	35.14	22.78		0.75
44	27.19	35.14	22.78		0.69
84	27.07	35.12	22.80		0.35
159	23.61	34.98	23.76		0.44
230	10.80	34.61	26.53		2.02
305	09.16	34.62	26.82		2.16
376	08.75	34.61	26.87		2.26
447	08.26	34.60	26.94		2.50
592	06.88	34.52	27.08		2.83
592	06.93	34.52	27.07		
755	05.77	34.52	27.22		2.78
925	04.88	34.52	27.33		2.73

## INTERPOLATED AND CALCULATED

DEPTH (m)	T (°C)	S (‰)	$\sigma_t$ (gm/l)	$\Delta D$ (dyn. m)	$\Delta D 1000 - \Delta D$ (dyn. m)
00	27.17	35.14	22.79	0.000	1.801
10	27.19	35.16	22.80	0.051	1.751
20	27.18	35.14	22.79	0.102	1.700
30	27.18	35.14	22.79	0.152	1.649
50	27.16	35.14	22.79	0.254	1.547
75	27.10	35.12	22.80	0.382	1.420
100	26.98	35.11	22.83	0.509	1.292
150	24.10	35.01	23.64	0.745	1.056
200	13.71	34.58	25.94	0.907	0.894
250	10.00	34.63	26.68	0.996	0.805
300	09.17	34.62	26.81	1.064	0.737
400	08.57	34.61	26.90	1.192	0.609
500	07.68	34.56	27.00	1.312	0.489
600	06.85	34.52	27.08	1.425	0.376
700	06.13	34.52	27.18	1.529	0.272
800	05.45	34.52	27.26	1.625	0.176
1000 <sup>1/</sup>	04.62	34.52	27.36	1.801	0.000

<sup>1/</sup> Extrapolated values.

## STATION 6

M/V Hugh M. Smith: Cruise 14, 2°56'N, 154°59'W, January 29, 1952. Messenger time: 2023 GCT. Weather: 02, cloud coverage 4. Wind: 040°, 19 kt. Sea: 5-8 ft. Wire angle: 47°

## OBSERVED

DEPTH (m)	T (°C)	S (‰)	$\sigma_t$ (g/l)	O <sub>2</sub> (ml/l)	PO <sub>4</sub> -P ( $\mu\text{g at/l}$ )
00	27.10	35.08	22.77		
08	27.12	35.07	22.75		
20	27.07	35.08	22.77		
41	27.07	35.08	22.77		
77	27.07	35.07	22.77		
141	26.76	35.11	22.90		
190	12.59	34.58	26.17		
240	10.39	34.69	26.66		
295	10.06	34.69	26.72		
350	09.43	34.67	26.81		
475	08.53	34.61	26.91		
475	08.60	34.61	26.89		
607	06.86	34.54	27.10		
758	05.62	34.51	27.23		

## INTERPOLATED AND CALCULATED

DEPTH (m)	T (°C)	S (‰)	$\sigma_t$ (gm/l)	$\Delta D$ (dyn. m)	$\Delta D 1000 - \Delta D$ (dyn. m)
00	27.10	35.08	22.77	0.000	1.750
10	27.10	35.07	22.76	0.051	1.699
20	27.07	35.08	22.78	0.102	1.648
30	27.07	35.08	22.78	0.153	1.597
50	27.07	35.07	22.77	0.255	1.495
75	27.07	35.07	22.77	0.363	1.367
100	26.98	35.09	22.82	0.511	1.239
150	20.10	34.83	24.63	0.724	1.026
200	11.62	34.62	26.38	0.851	0.899
250	10.22	34.69	26.68	0.930	0.820
300	09.97	34.69	26.73	1.000	0.750
400	09.18	34.66	26.84	1.135	0.615
500	08.14	34.58	26.94	1.260	0.489
600	06.96	34.54	27.08	1.376	0.374
700	06.07	34.52	27.19	1.480	0.270
800 <sup>1/</sup>	05.40	34.52	27.27	1.575	0.175
1000 <sup>1/</sup>	04.58	34.52	27.36	1.750	0.000

<sup>1/</sup> Extrapolated values.

## STATION 7

M/V Hugh M. Smith: Cruise 14, 1°54'N, 155°03'W, January 30, 1952. Messenger time: First cast 0655 GCT, second cast 0729 GCT. Weather: 50, cloud coverage 10. Wind: 050°, 18 kt. Sea: 5-8 ft. Wire angle: <sup>1/</sup> First cast 58°, second cast 40°

## OBSERVED

DEPTH (m)	T (°C)	S (‰)	$\sigma_t$ (g/l)	O <sub>2</sub> (ml/l)	PO <sub>4</sub> -P ( $\mu$ g at/l)
00	27.40	35.11	22.71		
13	27.42	35.10	22.68		
29	27.38	35.08	22.68		
<u>59</u>	<u>27.32</u>	<u>35.11</u>	<u>22.72</u>		
117	25.00	35.07	23.41		
231	11.40	34.80	26.56		
341	10.81	34.70	26.60		
463	09.32	34.68	26.84		
575	08.08	34.61	26.98		
696	06.58	34.52	27.12		
938	04.83	34.51	27.33		
938	04.85	34.51	27.33		
1209	03.74	34.54	27.47		
<u>2/</u>					

## INTERPOLATED AND CALCULATED

DEPTH (m)	T (°C)	S (‰)	$\sigma_t$ (gm/l)	$\Delta D$ (dyn. m)	$\Delta D 1000 - \Delta D$ (dyn. m)
00	27.40	35.11	22.69	0.000	1.770
10	27.41	35.11	22.69	0.052	1.718
20	27.40	35.09	22.68	0.103	1.666
30	27.38	35.08	22.68	0.155	1.614
50	27.34	35.11	22.71	0.259	1.511
75	27.30	35.11	22.73	0.388	1.381
100	27.22	35.11	22.75	0.518	1.252
150	16.62	34.80	25.47	0.711	1.058
200	11.76	34.83	26.52	0.815	0.954
250	11.37	34.80	26.57	0.893	0.876
300	11.13	34.75	26.58	0.971	0.799
400	10.10	34.68	26.70	1.120	0.650
500	08.96	34.66	26.88	1.256	0.513
600	07.71	34.58	27.01	1.379	0.391
700	06.50	34.52	27.13	1.490	0.279
800	05.64	34.51	27.23	1.591	0.179
1000	04.58	34.52	27.36	1.770	0.000

1/ Under way to reduce wire angle.

2/ Bottom bottle pretripped, but was not recast.



## STATION 8

M/V Hugh M. Smith: Cruise 14, 0°54'N, 155°11'W, January 30, 1952. Messenger time: First cast 1638 GCT, second cast 1726 GCT, third cast 1811 GCT. Weather: 01, cloud coverage 1. Wind: 020°, 13 kt. Sea: 3-5 ft. Wire angle: First cast 50°, 1/ second cast 55°

## OBSERVED

DEPTH (m)	T (°C)	S (‰)	$\sigma_t$ (g/l)	O <sub>2</sub> (ml/l)	PO <sub>4</sub> -P ( $\mu\text{g at/l}$ )
00	27.25	35.06	22.70		
10	27.26	35.03	22.68		
21	27.24	35.04	22.69		
<u>42</u>	27.22	35.06	22.71		
74	27.04	35.06	22.77		
139	19.00	34.82	24.90		
202	12.72	34.88	26.37		
267	11.66	34.84	26.54		
338	10.43	34.74	26.69		
<u>2/</u>					

## INTERPOLATED AND CALCULATED

DEPTH (m)	T (°C)	S (‰)	$\sigma_t$ (gm/l)	$\Delta D$ (dyn. m)	$\Delta D 1000 - \Delta D$ (dyn. m)
00	27.25	35.06	22.70		
10	27.26	35.03	22.68		
20	27.24	35.04	22.69		
30	27.23	35.05	22.70		
50	27.20	35.06	22.72		
75	27.04	35.06	22.77		
100	26.17	35.10	23.14		
150	16.80	34.96	25.55		
200	12.83	34.88	26.35		
250	11.88	34.85	26.52		
300	11.07	34.79	26.62		
400 <u>3/</u>	09.48	34.67	26.80		
<u>4/</u>					

1/ Underway to reduce wire angle on cast No. 1

2/ Temperature and depths uncertain below this. Bottles were malfunctioning because of large wire angle.

3/ Extrapolated values.

4/ Observations too shallow to allow extrapolation.

## STATION 9

M/V Hugh M. Smith: Cruise 14, 0°06'S, 155°14'W, January 31, 1952. Messenger time: 0421 GCT. Weather: 02, cloud coverage 4. Wind: 060°, 8 kt. Sea: < 1 ft. Wire angle: 1/ 48°

## OBSERVED

DEPTH (m)	T (°C)	S (°/oo)	$\sigma_t$ (g/l)	O <sub>2</sub> (ml/l)	PO <sub>4</sub> -P ( $\mu$ g at/l)
02	27.31	35.04	22.67		
14	27.14	35.04	22.72		
30	26.96	35.07	22.80		
60	26.68	35.23	23.01		
116	25.35	35.26	23.45		
222	13.04	34.97	26.38		
324	11.46	34.82	26.57		
437	09.30	34.67	26.83		
543	07.51	34.60	27.05		
659	06.31	34.54	27.17		
894	04.94	34.55	27.35		
894	04.89	34.55	27.36		
1145	03.83	34.56	27.47		
<u>2/</u>					

## INTERPOLATED AND CALCULATED

DEPTH (m)	T (°C)	S (°/oo)	$\sigma_t$ (gm/l)	$\Delta D$ (dyn. m)	$\Delta D 1000 - \Delta D$ (dyn. m)
00	27.31	35.04	22.67	0.000	1.720
10	27.20	35.04	22.71	0.052	1.669
20	27.05	35.05	22.76	0.103	1.617
30	26.96	35.07	22.81	0.154	1.566
50	26.79	35.18	22.94	0.254	1.466
75	26.50	35.25	23.09	0.376	1.344
100	25.89	35.26	23.28	0.495	1.225
150	18.60	35.08	25.20	0.602	1.038
200	13.43	35.00	26.32	0.798	0.923
250	12.60	34.93	26.44	0.834	0.837
300	11.83	34.86	26.53	0.966	0.755
400	10.00	34.71	26.74	1.115	0.605
500	08.20	34.62	26.97	1.245	0.475
600	06.85	34.56	27.11	1.358	0.362
700	06.00	34.54	27.21	1.459	0.261
800	05.39	34.55	27.30	1.552	0.168
1000	04.43	34.55	27.40	1.720	0.000

1/ Underway to reduce wire angle.

2/ Bottom bottle pretripped, but was not recast.

## STATION 10

M/V Hugh M. Smith: Cruise 14, 1°10'S, 155°08'W, January 31, 1952. Messenger time: 1405 GCT. Weather: 02, cloud coverage 2. Wind: 030°, 6 kt. Sea: < 1 ft. Wire angle: 25°

## OBSERVED

DEPTH (m)	T (°C)	S (°/oo)	$\sigma_t$ (g/l)	O <sub>2</sub> (ml/l)	PO <sub>4</sub> -P ( $\mu\text{g at/l}$ )
00	26.87	35.31	23.02		
14	26.72	35.29	23.05		
32	26.64	35.31	23.09		
66	26.56	35.32	23.12		
129	25.55	35.47	23.55		
252	11.72	34.95	26.54		
371	10.80	34.79	26.67		
498	07.94	34.61	27.00		
620	06.69	34.54	27.12		
749	05.93	34.52	27.20		
1015	04.40	34.53	27.39		
1015	04.45	34.53	27.39		
1293	03.44	34.60	27.54		
1585	03.02	34.59	27.50		

## INTERPOLATED AND CALCULATED

DEPTH (m)	T (°C)	S (°/oo)	$\sigma_t$ (gm/l)	$\Delta D$ (dyn. m)	$\Delta D 1000 - \Delta D$ (dyn. m)
00	26.87	35.31	23.02	0.000	1.735
10	26.77	35.29	23.03	0.048	1.687
20	26.70	35.29	23.05	0.097	1.639
30	26.65	35.30	23.08	0.145	1.590
50	26.60	35.32	23.11	0.241	1.494
75	26.52	35.33	23.14	0.361	1.375
100	26.13	35.41	23.37	0.479	1.257
150	21.70	35.39	24.62	0.679	1.057
200	13.88	35.02	26.24	0.810	0.925
250	11.83	34.96	26.53	0.896	0.840
300	11.41	34.93	26.59	0.974	0.761
400	10.12	34.75	26.76	1.121	0.615
500	07.88	34.61	27.01	1.249	0.488
600	06.83	34.55	27.11	1.359	0.377
700	06.18	34.52	27.17	1.462	0.273
800	05.62	34.52	27.24	1.560	0.176
1000	04.48	34.53	27.38	1.735	0.000

## STATION 11

M/V Hugh M. Smith: Cruise 14, 2°00'S, 155°03'W, January 31, 1952. Messenger time: 2124 GCT. Weather: 01, cloud coverage 1. Wind: 020°, 11 kt. Sea: < 1 ft. Wire angle: 35°

## OBSERVED

DEPTH (m)	T (°C)	S (°/oo)	$\sigma_t$ (g/l)	O <sub>2</sub> (ml/l)	PO <sub>4</sub> -P ( $\mu$ g at/l)
00	27.10	35.27	22.91		
08	26.87	35.26	22.90		
25	26.68	35.26	23.04		
49	26.72	35.29	23.05		
95	26.66	35.34	23.10		
191	14.17	35.12	26.26		
286	11.51	34.83	26.57		
379	10.76	34.79	26.67		
476	08.93	34.69	26.91		
571	07.73	34.61	27.03		
771	05.61	34.52	27.24		
771	05.65	34.52	27.24		
973	04.54	34.56	27.40		
1178	03.79	34.56	27.47		

## INTERPOLATED AND CALCULATED

DEPTH (m)	T (°C)	S (°/oo)	$\sigma_t$ (gm/l)	$\Delta D$ (dyn. m)	$\Delta D 1000 - \Delta D$ (dyn. m)
00	27.10	35.27	22.91	0.000	1.757
10	26.93	35.26	22.96	0.049	1.708
20	26.74	35.26	23.02	0.092	1.659
30	26.68	35.28	23.05	0.147	1.610
50	26.73	35.30	23.05	0.244	1.514
75	26.71	35.33	23.09	0.365	1.393
100	26.62	35.36	23.13	0.485	1.272
150	22.35	35.45	24.49	0.684	1.064
200	13.38	35.05	26.37	0.825	0.932
250	11.89	34.87	26.53	0.908	0.850
300	11.42	34.83	26.50	0.986	0.771
400	10.39	34.76	26.72	1.134	0.623
500	09.62	34.67	26.94	1.267	0.490
600	07.39	34.59	27.06	1.384	0.373
700	06.23	34.52	27.17	1.490	0.267
800	05.46	34.52	27.26	1.587	0.171
1000	04.41	34.56	27.41	1.757	0.000

## STATION 12

M/V Hugh M. Smith; Cruise 14, 3°00'S, 154°58'W, February 1, 1952. Messenger time: 0617 GCT. Weather: 21, cloud coverage not recorded. Wind: 000°, 11 kt. Sea: < 1 ft. Wire angle: 27°

## OBSERVED

DEPTH (m)	T (°C)	S (‰)	$\sigma_t$ (g/l)	O <sub>2</sub> (ml/l)	PO <sub>4</sub> -P ( $\mu\text{g at/l}$ )
00	27.37	35.25	22.89		
10	27.34	35.34	22.89		
27	27.08	35.35	22.97		
54	27.04	35.39	23.02		
108	27.13	35.44	23.03		
<u>1/</u>					

## INTERPOLATED AND CALCULATED

DEPTH (m)	T (°C)	S (‰)	$\sigma_t$ (gm/l)	$\Delta D$ (dyn. m)	$\Delta D 1000 - \Delta D$ (dyn. m)
00	27.37	35.35	22.89		
10	27.34	35.34	22.88		
20	27.21	35.34	22.93		
30	27.07	35.36	22.99		
50	27.07	35.38	23.00		
75	27.07	35.40	23.02		
100	27.12	35.44	23.03		
<u>2/</u>					

1/ Cast pretripped below this.

2/ Observations too shallow to allow extrapolation.

## STATION 13

M/V Hugh M. Smith: Cruise 14, 4°00'S, 155°07'W, February 1, 1952. Messenger time: First cast 1548 GCT, second cast 1617 GCT. Weather: 15, cloud coverage 7. Wind: 040°, 14 kt. Sea: 1-3 ft. Wire angle: First cast 17°, second cast 20°

## OBSERVED

DEPTH (m)	T (°C)	S (°/oo)	$\sigma_t$ (g/l)	O <sub>2</sub> (ml/l)	PO <sub>4</sub> -P ( $\mu$ g at/l)
00	27.65	35.55	22.94		
09	27.69	35.53	22.92		
28	27.64	35.52	22.92		
56	27.54	35.53	22.96		
112	27.60	35.56	22.96		
222	19.26	35.46	25.58		
330	10.41	34.76	26.71		
434	08.74	34.65	26.91		
541	07.48	34.59	27.05		
646	06.64	34.54	27.13		
861	05.18	34.52	27.30		
861	05.22	34.52	27.29		
1072	04.23	34.54	27.42		
1280	03.56	34.56	27.50		

## INTERPOLATED AND CALCULATED

DEPTH (m)	T (°C)	S (°/oo)	$\sigma_t$ (gm/l)	$\Delta D$ (dyn. m)	$\Delta D 1000 - \Delta D$ (dyn. m)
00	27.65	35.55	22.94	0.000	1.873
10	27.68	35.52	22.91	0.049	1.824
20	27.68	35.52	22.91	0.099	1.774
30	27.63	35.52	22.93	0.149	1.724
50	27.55	35.52	22.95	0.248	1.625
75	27.56	35.54	22.96	0.371	1.502
100	27.58	35.55	22.96	0.495	1.378
150	26.60	35.71	23.40	0.734	1.139
200	20.82	35.60	25.02	0.924	0.949
250	13.42	35.04	26.36	1.044	0.829
300	11.19	34.83	26.63	1.125	0.748
400	09.22	34.68	26.85	1.265	0.608
500	07.87	34.62	27.02	1.387	0.486
600	06.92	34.56	27.11	1.498	0.375
700	06.20	34.53	27.18	1.601	0.272
800	05.50	34.52	27.26	1.698	0.175
1000	04.56	34.53	27.37	1.873	0.000

## STATION 14

M/V Hugh M. Smith: Cruise 14, 4°58'S, 155°00'W, February 2, 1952. Messenger time: 0441 GCT. Weather: 02, cloud coverage 6. Wind: 060°, 18 kt. Sea: 3-5 ft. Wire angle: 32°

## OBSERVED

DEPTH (m)	T (°C)	S (‰)	$\sigma_t$ (g/l)	O <sub>2</sub> (ml/l)	PO <sub>4</sub> -P ( $\mu\text{g at/l}$ )
00	27.79	35.45	22.82		
09	27.84	35.47	22.82		
26	27.72	35.43	22.83		
51	27.66	35.48	22.89		
98	27.62	35.56	22.96		
191	21.10	35.88	25.15		
283	11.20	34.82 <sup>1/</sup>	26.63		
373	09.67	34.70	26.79		
467	08.51	34.63	26.92		
560	07.56	34.58	27.03		
758	05.90	34.51	27.20		
758	05.95	34.51	27.20		
952	04.69	34.51	27.35		
1149	03.69	34.54	27.44		

## INTERPOLATED AND CALCULATED

DEPTH (m)	T (°C)	S (‰)	$\sigma_t$ (gm/l)	$\Delta D$ (dyn. m)	$\Delta D 1000 - \Delta D$ (dyn. m)
00	27.79	35.45	22.82	0.000	1.842
10	27.84	35.47	22.82	0.050	1.791
20	27.74	35.45	22.84	0.101	1.741
30	27.70	35.44	22.84	0.151	1.691
50	27.66	35.48	22.89	0.252	1.590
75	27.64	35.50	22.91	0.377	1.465
100	27.62	35.57	22.96	0.501	1.340
150	26.25	35.98	23.71	0.732	1.109
200	18.52	35.63	25.64	0.900	0.942
250	12.62	34.97	26.46	1.002	0.839
300	10.84	34.79	26.66	1.080	0.762
400	09.32	34.63	26.83	1.219	0.623
500	08.14	34.61	26.97	1.344	0.497
600	07.17	34.56	27.07	1.459	0.383
700	06.34	34.52	27.15	1.566	0.276
800	05.60	34.51	27.24	1.665	0.177
1000	04.47	34.52	27.38	1.842	0.000

<sup>1/</sup> This sample may possibly have been accidentally contaminated, but appears to be good.

## STATION 15

M/V Hugh M. Smith: Cruise 14, 5°54'S, 155°03'W, February 2, 1952. Messenger time: 1411 GCT. Weather: 02, cloud coverage 2. Wind: 060°, 18 kt. Sea: 3-5 ft. Wire angle: 32°

## OBSERVED

DEPTH (m)	T (°C)	S (°/∞)	$\sigma_t$ (g/l)	O <sub>2</sub> (ml/l)	PO <sub>4</sub> -P ( $\mu$ g at/l)
00	27.79	35.52	22.87		
09	27.82	35.54	22.88		
26	27.78	35.54	22.89		
51	27.81	35.55	22.89		
102	28.07	35.76	22.96		
204	21.94	36.09	25.08		
305	11.46	34.83	26.58		
404	08.88	34.67	26.89		
507	07.84	34.58	26.99		
608	07.04	34.54	27.07		
822	05.45	34.52	27.26		
1033	04.30	34.54	27.41		
1240	03.66	34.58	27.51		

## INTERPOLATED AND CALCULATED

DEPTH (m)	T (°C)	S (°/∞)	$\sigma_t$ (gm/l)	$\Delta D$ (dyn. m)	$\Delta D 1000 - \Delta D$ (dyn. m)
00	27.79	35.52	22.87	0.000	1.898
10	27.80	35.54	22.89	0.050	1.848
20	27.80	35.54	22.89	0.100	1.798
30	27.79	35.54	22.89	0.150	1.748
50	27.81	35.55	22.89	0.250	1.648
75	28.13	35.65	22.86	0.375	1.523
100	28.06	35.76	22.97	0.500	1.398
150	27.22	36.02	23.43	0.739	1.160
200	22.32	36.10	24.98	0.928	0.969
250	15.18	35.30	26.18	1.054	0.844
300	11.64	34.86	26.56	1.141	0.757
400	08.93	34.68	26.90	1.281	0.617
500	07.94	34.58	26.97	1.403	0.495
600	07.10	34.54	27.06	1.517	0.380
700	06.33	34.52	27.15	1.624	0.274
800	05.60	34.52	27.24	1.723	0.175
1000	04.48	34.54	27.39	1.898	0.000



## STATION 16

M/V Hugh M. Smith: Cruise 14, 6°50'S, 155°05'W, February 2, 1952. Messenger time: 2322 GCT. Weather: 02, cloud coverage 5. Wind: 020°, 13 kt. Sea: 3-5 ft. Wire angle: 12°

## OBSERVED

DEPTH (m)	T (°C)	S (‰)	$\sigma_t$ (g/l)	O <sub>2</sub> (ml/l)	PO <sub>4</sub> -P ( $\mu\text{g at/l}$ )
00	28.49	35.75	22.82		
10	28.48	35.76	22.83		
30	28.40	35.76	22.86		
59	28.35	35.76	22.87		
118	28.18	35.76	22.93		
233	19.69	35.92	25.56		
347	09.94	34.72	26.76		
458	08.22	34.61	26.95		
573	06.82	34.53	27.09		
682	06.02	34.52	27.19		
910	04.81	34.52	27.34		
1132	04.10	34.54	27.43		
1344	03.54	34.54	27.49		

## INTERPOLATED AND CALCULATED

DEPTH (m)	T (°C)	S (‰)	$\sigma_t$ (gm/l)	$\Delta D$ (dyn. m)	$\Delta D 1000 - \Delta D$ (dyn. m)
00	28.49	35.75	22.82	0.000	1.911
10	28.48	35.76	22.83	0.050	1.860
20	28.44	35.76	22.84	0.101	1.810
30	28.40	35.76	22.86	0.151	1.760
50	28.38	35.76	22.86	0.252	1.659
75	28.30	35.76	22.89	0.377	1.534
100	28.28	35.76	22.90	0.503	1.408
150	27.18	36.03	23.46	0.742	1.169
200	23.00	36.13	24.81	0.936	0.975
250	17.44	35.62	25.90	1.072	0.839
300	12.42	34.95	26.49	1.168	0.743
400	09.06	34.66	26.86	1.314	0.597
500	07.68	34.57	27.00	1.436	0.475
600	06.63	34.53	27.12	1.546	0.365
700	05.87	34.52	27.21	1.647	0.264
800	05.25	34.52	27.29	1.740	0.171
1000	04.50	34.53	27.38	1.911	0.000

## STATION 17

M/V Hugh M. Smith: Cruise 14, 7°56'S, 179°53'W, February 15, 1952. Messenger time: 1236 GCT. Weather: 03, cloud coverage 3. Wind: 040°, 8 kt. Sea: 1-3 ft. Wire angle: 13°

## OBSERVED

DEPTH (m)	T (°C)	S (‰)	$\sigma_t$ (g/l)	O <sub>2</sub> (ml/l)	PO <sub>4</sub> -P ( $\mu\text{g at/l}$ )
00	29.58	34.90	21.81		0.35
09	29.60	34.89	21.80		0.44
23	29.42	34.90	21.87		0.46
52	29.36	35.15	22.08		0.45
104	28.36	35.60	22.75		0.69
207	22.86	36.07	24.80		0.94
311	13.54	34.97	26.28		1.76
420	09.23	34.68	26.85		2.26
525	07.52	34.56	27.02		2.41
630	06.54	34.52	27.13		2.47
835	05.11	34.50	27.29		2.72
835	05.15	34.50	27.28		
1044	04.28	34.53	27.40		2.81
1245	03.72	34.53	27.46		2.66

## INTERPOLATED AND CALCULATED

DEPTH (m)	T (°C)	S (‰)	$\sigma_t$ (gm/l)	$\Delta D$ (dyn. m)	$\Delta D 1000 - \Delta D$ (dyn. m)
00	29.58	34.90	21.82	0.000	2.037
10	29.60	34.89	21.80	0.060	1.976
20	29.50	34.90	21.84	0.120	1.916
30	29.41	34.94	21.90	0.180	1.857
50	29.37	35.13	22.06	0.297	1.739
75	29.18	35.29	22.24	0.440	1.596
100	28.49	35.55	22.67	0.576	1.460
150	26.20	35.96	23.71	0.814	1.222
200	23.42	36.09	24.66	1.006	1.031
250	18.59	35.67	25.65	1.152	0.885
300	14.40	35.09	26.19	1.261	0.775
400	09.72	34.71	26.79	1.426	0.611
500	07.24	34.58	26.99	1.552	0.485
600	06.79	34.52	27.09	1.664	0.372
700	06.00	34.51	27.19	1.768	0.269
800	05.32	34.50	27.26	1.863	0.174
1000	04.45	34.52	27.38	2.037	0.000

## STATION 18

M/V Hugh M. Smith: Cruise 14, 7°01'S, 179°49'W, February 15, 1952. Messenger time: 2219 GCT. Weather: 02, cloud coverage 4. Wind: 050°, 12 kt. Sea: 1-3 ft. Wire angle: 17°

## OBSERVED

DEPTH (m)	T (°C)	S (‰)	$\sigma_t$ (g/l)	O <sub>2</sub> (ml/l)	PO <sub>4</sub> -P ( $\mu\text{g at/l}$ )
00	29.32	34.91	21.91		0.38
10	29.23	34.90	21.91		0.39
24	29.24	34.94	21.96		0.40
52	29.42	35.10	22.02		0.44
102	28.99	35.51	22.47		0.66
205	23.96	36.19	24.58		0.86
308	14.12	35.06	26.23		1.74
416	09.10	34.66	26.86		2.25
519	07.45	34.57	27.04		2.40
823	05.19	34.50	27.28		2.68
823	05.22	34.50	27.27		
621	06.43	34.51	27.13		2.47
1026	04.26	34.52	27.40		2.80
1223	03.70	34.55	27.48		2.82

## INTERPOLATED AND CALCULATED

DEPTH (m)	T (°C)	S (‰)	$\sigma_t$ (gm/l)	$\Delta D$ (dyn. m)	$\Delta D 1000 - \Delta D$ (dyn. m)
00	29.32	34.91	21.91	0.000	2.084
10	29.28	34.90	21.92	0.059	2.025
20	29.26	34.92	21.94	0.118	1.966
30	29.23	34.97	21.99	0.177	1.907
50	29.40	35.08	22.01	0.294	1.790
75	29.25	35.33	22.25	0.437	1.646
100	29.00	35.49	22.45	0.576	1.508
150	28.08	35.77	22.97	0.837	1.247
200	24.45	36.19	24.42	1.052	1.031
250	18.80	35.72	25.64	1.204	0.879
300	14.80	35.15	26.15	1.315	0.769
400	09.55	34.69	26.80	1.481	0.603
500	07.67	34.58	27.01	1.605	0.478
600	06.63	34.52	27.11	1.715	0.368
700	05.90	34.51	27.20	1.817	0.267
800	05.32	34.51	27.27	1.912	0.172
1000	04.39	34.52	27.39	2.084	0.000

## STATION 19

M/V Hugh M. Smith: Cruise 14, 6°04'S, 179°59'W, February 16, 1952. Messenger time: 0727 GCT. Weather: 02, cloud coverage 4. Wind: 050°, 17 kt. Sea: 3-5 ft. Wire angle: 28°

## OBSERVED

DEPTH (m)	T (°C)	S (‰)	$\sigma_t$ (g/l)	O <sub>2</sub> (ml/l)	PO <sub>4</sub> -P (µg at/l)
00	29.37	35.47	22.31		0.47
08	29.40	35.44	22.28		0.49
26	29.34	35.45	22.31		0.52
50	29.12	35.46	22.39		0.65
101	28.81	35.58	22.58		0.67
198	23.88	36.25	24.65		0.86
297	14.15	35.11	26.26		1.76
392	10.34	34.78	26.74		2.12
493	08.20	34.63	26.97		2.28
592	07.16	34.57	27.08		2.37
802	05.32	34.52	27.28		2.63
802	05.35	34.52	27.27		
1013	04.36	34.53	27.40		2.70
1224	03.72	34.57	27.49		2.79

## INTERPOLATED AND CALCULATED

DEPTH (m)	T (°C)	S (‰)	$\sigma_t$ (gm/l)	$\Delta D$ (dyn. m)	$\Delta D 1000 - \Delta D$ (dyn. m)
00	29.37	35.47	22.31	0.000	2.010
10	29.40	35.44	22.28	0.055	1.955
20	29.39	35.44	22.29	0.111	1.899
30	29.28	35.45	22.33	0.167	1.844
50	29.12	35.46	22.39	0.277	1.734
75	29.00	35.50	22.46	0.413	1.597
100	28.82	35.58	22.58	0.547	1.463
150	26.91	36.02	23.53	0.792	1.218
200	23.82	36.25	24.66	0.988	1.022
250	18.00	35.61	25.76	1.131	0.879
300	14.08	35.10	26.26	1.236	0.774
400	10.12	34.76	26.76	1.398	0.612
500	08.11	34.62	26.98	1.527	0.483
600	07.09	34.57	27.09	1.640	0.370
700	06.19	34.54	27.19	1.744	0.266
800	05.36	34.52	27.27	1.839	0.171
1000	04.39	34.53	27.39	2.010	0.000

## STATION 20

M/V Hugh M. Smith: Cruise 14, 5°03'S, 179°59'W, February 16, 1952. Messenger time: 1705 GCT. Weather: 02, cloud coverage not recorded. Wind: 060°, 14 kt. Sea: 1-3 ft. Wire angle: 22°

## OBSERVED

DEPTH (m)	T (°C)	S (°/∞)	$\sigma_t$ (g/l)	O <sub>2</sub> (ml/l)	PO <sub>4</sub> -P ( $\mu$ g at/l)
00	29.14	35.51	22.42		0.51
09	29.18	35.47	22.38		0.51
23	29.15	35.47	22.39		0.58
50	29.18	35.50	22.40		0.58
99	29.03	35.60	22.52		0.61
149	28.01	35.62	22.88		0.84
197	24.54	36.26	24.45		0.90
246	18.00	35.52	25.69		1.35
295	12.58	34.95	26.46		1.97
349	9.90	34.73	26.78		2.25
398	9.10	34.69	26.88		2.32
398	9.05	34.69	26.89		
496	8.00	34.62	27.00		2.43
597	7.12	34.57	27.09		2.56

## STATION 21

M/V Hugh M. Smith: Cruise 14, 3°59'S, 179°59'W, February 17, 1952. Messenger time: 0242 GCT. Weather: 01, cloud coverage 2. Wind: 070°, 16 kt. Sea: 3-5 ft. Wire angle: 22°

## OBSERVED

DEPTH (m)	T (°C)	S (°/∞)	$\sigma_t$ (g/l)	O <sub>2</sub> (ml/l)	PO <sub>4</sub> -P ( $\mu$ g at/l)
00	28.76	35.59	22.61		0.64
09	28.74	35.60	22.62		0.64
29	28.59	35.59	22.66		0.64
55	28.59	35.58	22.66		0.64
111	28.62	35.59	22.65		0.64
164	27.59	35.67	23.05		0.82
218	21.76	36.01	25.10		1.01
274	13.55	35.03	26.32		1.95
328	10.35	34.78	26.74		2.23
382	9.30	34.67	26.83		2.32
433	8.78	34.65	26.90		2.44
433	8.82	34.65	26.89		
543	7.60	34.60	27.04		2.61
651	6.54	34.53	27.13		2.71

## STATION 22

M/V Hugh M. Smith: Cruise 14, 2°56'S, 180°00'W, February 17, 1952. Messenger time: 1212 GCT. Weather: 02, cloud coverage not recorded. Wind: 050°, 20 kt. Sea: 3-5 ft. Wire angle: 37°

## OBSERVED

DEPTH (m)	T (°C)	S (‰)	$\sigma_t$ (g/l)	O <sub>2</sub> (ml/l)	PO <sub>4</sub> -P ( $\mu$ g at/l)
00	28.17	35.55	22.77		1/
09	28.20	35.55	22.76		
25	28.17	35.53	22.76		
48	28.16	35.56	22.78		
92	28.20	35.57	22.78		
132	27.90	35.56	22.87		
171	25.71	35.74	23.70		
206	18.04	35.52	25.68		
241	12.82	34.98	26.43		
280	11.32	34.86	26.63		
315	10.33	34.76	26.73		
315	10.36	34.76	26.72		
399	9.12	34.66	26.85		
488	7.98	34.61	26.99		

1/ Phosphate analysis on this station was faulty.

## STATION 23

M/V Hugh M. Smith: Cruise 14, 1°52'S, 179°54'E, February 17, 1952. Messenger time: 2234 GCT. Weather: 02, cloud coverage 2. Wind: 060°, 10 kt. Sea: 1-3 ft. Wire angle: 43°

## OBSERVED

DEPTH (m)	T (°C)	S (‰)	$\sigma_t$ (g/l)	O <sub>2</sub> (ml/l)	PO <sub>4</sub> -P ( $\mu$ g at/l)
00	28.00	35.53	22.81		0.68
11	27.92	35.54	22.85		0.68
24	27.88	35.53	22.85		0.70
51	27.90	35.53	22.85		0.70
96	27.92	35.53	22.84		0.69
135	27.92	35.57	22.87		0.71
167	25.64	35.77	23.74		0.99
195	16.90	35.36	25.83		1.59
228	13.64	35.04	26.31		1.76
265	11.41	34.83	26.58		1.89
293	10.62	34.77	26.68		2.25
298	10.66	34.77	26.68		
370	9.65	34.75	26.80		2.41
469	9.04	34.69	26.89		2.55

## STATION 24

M/V Hugh M. Smith: Cruise 14, 0°59'S, 179°57'E, February 18, 1952. Messenger time: 0702 GCT. Weather: 02, cloud coverage 2. Wind: 070°, 13 kt. Sea: 1-3 ft. Wire angle: 1/ 35°

## OBSERVED

DEPTH (m)	T (°C)	S (°/oo)	$\sigma_t$ (g/l)	O <sub>2</sub> (ml/l)	PO <sub>4</sub> -P ( $\mu$ g at/l)
04	27.74	35.44	22.83		0.84
17	27.62	35.44	22.87		0.92
34	27.56	35.44	22.89		0.88
69	27.56	35.44	22.89		0.96
134	25.93	35.57	23.50		1.15
197	16.53	35.12	25.73		1.57
261	11.74	34.86	26.55		2.13
321	10.92	34.77	26.63		2.50
386	10.25	34.75	26.73		2.61
455	9.31	34.70	26.85		2.74
520	8.42	34.65	26.95		2.85
520	8.45	34.65	26.95		
647	6.44	34.56	27.17		3.12
787	5.24	34.55	27.31		3.13

1/ Underway to reduce wire angle.

## STATION 25

M/V Hugh M. Smith: Cruise 14, 0°02'N, 179°59'E, February 18, 1952. Messenger time: 1648 GCT. Weather: 02, cloud coverage not recorded. Wind: 060°, 9 kt. Sea: 1-3 ft. Wire angle: 1/ 27°

## OBSERVED

DEPTH (m)	T (°C)	S (°/oo)	$\sigma_t$ (g/l)	O <sub>2</sub> (ml/l)	PO <sub>4</sub> -P ( $\mu$ g at/l)
05	27.45	35.49	22.96		0.92
20	27.48	35.50	22.96		0.95
39	27.39	35.48	22.97		0.96
76	27.16	35.48	23.05		0.99
146	22.26	35.25	24.35		1.21
217	15.87	35.13	25.90		1.56
289	11.70	34.85	26.55		2.30
355	10.88	34.79	26.65		2.62
426	9.80	34.72	26.79		2.88
503	8.52	34.67	26.95		3.05
576	7.39	34.61	27.08		3.17
576	7.43	34.61	27.07		
715	5.88	34.54	27.23		3.16
866	4.82	34.53	27.35		3.24

1/ Underway to reduce wire angle.

## STATION 26

M/V Hugh M. Smith: Cruise 14, 1°03'N, 179°58'W, February 19, 1952. Messenger time: 0346 GCT. Weather: 03, cloud coverage 8. Wind: 090°, 13 kt. Sea: 1-3 ft. Wire angle: 49°

## OBSERVED

DEPTH (m)	T (°C)	S (‰)	$\sigma_t$ (g/l)	O <sub>2</sub> (ml/l)	PO <sub>4</sub> -P ( $\mu$ g at/l)
04	28.03	35.49	22.77		0.91
15	27.58	35.47	22.91		0.93
26	27.50	35.47	22.93		0.94
49	27.50	35.48	22.94		0.94
88	27.48	35.46	22.93		0.91
121	27.36	35.42	22.94		0.93
148	26.63	35.27	23.06		0.96
172	19.37	34.88	24.85		1.24
200	16.22	35.08	25.78		1.51
233	12.52	34.69	26.27		1.75
266	11.46	34.30	26.55		2.18
333	10.66	34.76	26.67		2.50
430	9.36	34.69	26.84		2.71

## STATION 27

M/V Hugh M. Smith: Cruise 14, 2°07'N, 179°57'W, February 19, 1952. Messenger time: 1336 GCT. Weather: 02, cloud coverage not recorded. Wind: 070°, 14 kt. Sea: 3-5 ft. Wire angle:  $\frac{1}{25}^\circ$

## OBSERVED

DEPTH (m)	T (°C)	S (‰)	$\sigma_t$ (g/l)	O <sub>2</sub> (ml/l)	PO <sub>4</sub> -P ( $\mu$ g at/l)
04	27.85	35.34	22.72		0.82
18	27.86	35.35	22.72		0.85
36	27.74	35.34	22.76		0.87
74	27.68	35.36	22.79		0.88
144	26.78	35.22	22.98		1.03
214	11.72	34.63	26.37		2.09
283	10.96	34.79	26.64		2.45
348	10.30	34.75	26.73		2.58
418	9.72	34.73	26.81		2.74
493	8.90	34.66	26.89		2.83
564	8.14	34.61	26.97		2.84
564	8.19	34.61	26.97		
703	6.14	34.53	27.19		3.26
855	4.92	34.53	27.33		3.28

$\frac{1}{25}$  Underway to reduce wire angle.



## STATION 28

M/V Hugh M. Smith: Cruise 14, 3°06'N, 179°57'W, February 19, 1952. Messenger time: 2237 GCT. Weather: 02, cloud coverage 8. Wind: 100°, 7 kt. Sea: 1-3 ft. Wire angle: 32°

## OBSERVED

DEPTH (m)	T (°C)	S (°/oo)	$\sigma_t$ (g/l)	O <sub>2</sub> (ml/l)	PO <sub>4</sub> -P ( $\mu$ g at/l)
00	28.11	35.22	22.54		0.78
13	28.03	35.23	22.58		0.81
30	28.00	35.27	22.62		0.86
63	28.02	35.31	22.64		0.91
122	27.94	35.29	22.65		0.91
176	22.86	35.00	23.99		0.96
231	12.43	34.55	26.17		2.16
284	9.96	34.64	26.70		2.74
343	9.12	34.68	26.87		2.80
409	8.48	34.63	26.93		2.77
474	7.93	34.61	27.00		2.86
474	7.99	34.61	26.99		
607	6.96	34.56	27.10		3.10
756	5.60	34.55	27.27		3.33

## STATION 29

M/V Hugh M. Smith: Cruise 14, 4°05'N, 179°55'W, February 20, 1952. Messenger time: 0741 GCT. Weather: 63, cloud coverage 10. Wind: 150°, 11 kt. Sea: 3-5 ft. Wire angle: 15°

## OBSERVED

DEPTH (m)	T (°C)	S (°/oo)	$\sigma_t$ (g/l)	O <sub>2</sub> (ml/l)	PO <sub>4</sub> -P ( $\mu$ g at/l)
00	27.98	34.89	22.34		0.80
10	28.09	35.23	22.56		0.80
29	28.01	35.25	22.60		0.81
59	28.00	35.25	22.60		0.80
115	28.00	35.25	22.60		0.80
173	27.35	35.17	22.75		0.90
230	11.81	34.55	26.29		2.23
289	9.26	34.61	26.79		2.65
343	8.66	34.61	26.89		2.59
400	8.12	34.60	26.96		2.74
452	7.68	34.58	27.01		2.80
452	7.73	34.58	27.00		
569	6.86	34.56	27.11		3.06
680	6.07	34.55	27.21		3.21

## STATION 30

M/V Hugh M. Smith: Cruise 14, 5°06'N, 179°50'W, February 20, 1952. Messenger time: 1637 GCT. Weather: '51, cloud coverage not recorded. Wind: 130°, 5 kt. Sea: 1-3 ft. Wire angle: 05°

## OBSERVED

DEPTH (m)	T (°C)	S (°/oo)	$\sigma_t$ (g/l)	O <sub>2</sub> (ml/l)	PO <sub>4</sub> -P ( $\mu$ g at/l)
00	28.17	34.88	22.27		0.65
10	28.22	34.89	22.26		0.61
31	28.22	34.92	22.28		0.71
60	28.20	34.96	22.32		0.77
120	26.96	35.22	22.92		0.99
177	19.88	34.88	24.72		1.22
236	11.34	34.60	26.42		2.55
293	9.68	34.64	26.74		2.82
351	8.96	34.65	26.87		2.93
408	8.42	34.64	26.95		2.82
461	8.07	34.59	26.96		2.83
461	8.12	34.59	26.95		
579	7.28	34.58	27.07		3.08
691	6.42	34.53	27.15		3.14

## STATION 31

M/V Hugh M. Smith: Cruise 14, 6°06'N, 179°44'W, February 21, 1952. Messenger time: 0141 GCT. Weather: 63, cloud coverage 10. Wind: 130°, 12 kt. Sea: 3-5 ft. Wire angle: 05°

## OBSERVED

DEPTH (m)	T (°C)	S (°/oo)	$\sigma_t$ (g/l)	O <sub>2</sub> (ml/l)	PO <sub>4</sub> -P ( $\mu$ g at/l)
00	28.07	34.69	22.16		0.63
10	28.10	34.69	22.15		0.54
25	28.08	34.71	22.17		0.58
55	28.12	34.70	22.15		0.64
110	27.58	34.71	22.33		0.64
165	15.78	34.63	25.53		1.52
218	11.14	34.58	26.44		2.60
271	9.88	34.65	26.72		2.84
324	9.24	34.65	26.83		2.87
382	8.66	34.62	26.89		2.89
436	8.35	34.62	26.94		2.94
436	8.39	34.62	26.94		
543	7.37	34.56	27.04		3.17
650	6.50	34.53	27.14		3.32

## STATION 32

M/V Hugh M. Smith: Cruise 14, 7°04'N, 179°59'E, February 21, 1952. Messenger time: 1040 GCT. Weather: 02, cloud coverage not recorded. Wind: 080°, 13 kt. Sea: 3-5 ft. Wire angle: 03°  
OBSERVED

DEPTH (m)	T (°C)	S (°/oo)	$\sigma_t$ (g/l)	O <sub>2</sub> (ml/l)	PO <sub>4</sub> -P ( $\mu$ g at/l)
00	27.92 <sup>1/</sup>	34.70	22.22 <sup>1/</sup>		0.49
10	27.96	34.68	22.19		0.57
30	27.92	34.70	22.22		0.51
60	27.94	34.70	22.21		0.56
120	20.53	34.87	24.54		0.73
180	13.00	34.51	26.03		1.92
240	10.37	34.60	26.60		2.74
297	9.32	34.64	26.80		2.79
355	8.77	34.63	26.89		2.82
413	8.32	34.60	26.93		2.78
466	7.90	34.60	27.00		2.86
466	7.96	34.60	26.99		
581	7.07	34.55	27.03		3.04
693	6.28	34.52	27.16		3.16

<sup>1/</sup> Auxiliary of surface bottle thermometer (a single protected thermometer was used in the surface bottle only) was broken. An average value from nearby bottles in the rack was used for correction; temperature and sigma-t may be in error by 0.01.

## STATION 33

M/V Hugh M. Smith: Cruise 14, 8°03'N, 179°58'W, February 21, 1952. Messenger time: 1936 GCT. Weather: 14, cloud coverage 8. Wind: 070°, 6 kt. Sea: 3-5 ft. Wire angle: 05°  
OBSERVED

DEPTH (m)	T (°C)	S (°/oo)	$\sigma_t$ (g/l)	O <sub>2</sub> (ml/l)	PO <sub>4</sub> -P ( $\mu$ g at/l)
05	27.52	34.70	22.35		0.62
15	27.54	34.69	22.33		0.60
31	27.50	34.70	22.35		0.62
60	27.53	34.69	22.34		0.66
113	19.28	34.80	24.81		0.82
165	12.17	34.47	26.17		2.29
219	10.56	34.58	26.55		2.86
272	10.00	34.66	26.71		2.95
325	9.53	34.66	26.78		3.08
383	9.03	34.65	26.86		3.03
437	8.51	34.61	26.91		3.08
437	8.55	34.61	26.90		
544	7.48	34.56	27.03		3.17
650	6.56	34.55	27.14		3.38

## STATION 34

M/V Hugh M. Smith: Cruise 14, 8°58'N, 179°55'W, February 22, 1952. Messenger time: first cast 0355 GCT, second cast 0429 GCT. Weather: 20, cloud coverage 9. Wind: 050°, 21 kt. Sea: 5-8 ft. Wire angle: first cast 25°, second cast 15°

## OBSERVED

DEPTH (m)	T (°C)	S (‰)	$\sigma_t$ (g/l)	O <sub>2</sub> (ml/l)	PO <sub>4</sub> -P ( $\mu\text{g at/l}$ )
00	27.05	34.48	22.34		0.50
10	27.08	34.49	22.33		0.51
30	27.02	34.49	22.35		0.54
58	27.03	34.49	22.35		0.58
116	16.20	34.63	25.44		1.36 <sup>1/</sup>
162	11.34	34.52	26.36		2.50
215	10.45	34.69	26.65		2.90
270	9.82	34.65	26.73		2.94
322	9.30	34.64	26.81		3.01
376	8.98	34.62	26.86		2.95
427	8.47	34.58	26.89		3.05
427	8.52	34.58	26.88		
540	7.47	34.56	27.03		3.21
650	6.72	34.53	27.11		3.23

<sup>1/</sup> This one bottle is second cast.

## STATION 35

M/V Hugh M. Smith: Cruise 14, 5°00'S, 168°57'W, March 2, 1952. Messenger time: 0409 GCT. Weather: 02, cloud coverage 2. Wind: 060°, 9 kt. Sea: <1 ft. Wire angle: 18°

## OBSERVED

DEPTH (m)	T (°C)	S (‰)	$\sigma_t$ (g/l)	O <sub>2</sub> (ml/l)	PO <sub>4</sub> -P ( $\mu\text{g at/l}$ )
00	28.89	35.58	22.56		0.48
10	28.38	35.56	22.71		0.51
23	28.31	35.58	22.75		0.50
52	28.29	35.60	22.77		0.50
103	27.70	35.53	22.91		0.66
153	27.52	35.67	23.07		0.70
202	22.54	36.09	24.91		0.84
251	15.90	35.27	26.00		1.49
301	12.02	34.92	26.54		1.92
355	9.83	34.75	26.80		2.13
404	9.08	34.69	26.88		2.30
404	9.12	34.69	26.88		
503	8.08	34.62	26.98		2.36
603	6.70	34.52	27.10		2.48

## STATION 36

M/V Hugh M. Smith: Cruise 14, 4°02'S, 168°58'W, March 2, 1952.  
 Messenger time: 1254 GCT. Weather: 00, cloud coverage not  
 recorded. Wind: 060°, 13 kt. Sea: < 1 ft. Wire angle: 28°

## OBSERVED

DEPTH (m)	T (°C)	S (°/oo)	$\sigma_t$ (g/l)	O <sub>2</sub> (ml/l)	PO <sub>4</sub> -P ( $\mu$ g at/l)
00	27.94	35.46	22.78		0.55
09	27.96	35.46	22.77		0.55
27	27.90	35.47	22.80		0.55
52	27.84	35.48	22.83		0.55
101	27.85	35.50	22.84		0.57
147	27.24	25.82	23.25		0.70
193	17.56	35.45	25.74		1.25
240	12.44	34.97	26.50		1.91
287	10.48	34.79	26.72		2.11
334	9.34	34.72	26.78		2.20
377	9.29	34.70	26.86		2.24
377	9.33	34.70	26.85		
474	8.18	34.62	26.97		2.41
569	7.31	34.58	27.06		2.65

## STATION 37

M/V Hugh M. Smith: Cruise 14, 3°04'S, 168°59'W, March 2, 1952.  
 Messenger time: 2231 GCT. Weather: 02, cloud coverage 3.  
 Wind: 070°, 14 kt. Sea: 1-3 ft. Wire angle: 45°

## OBSERVED

DEPTH (m)	T (°C)	S (°/oo)	$\sigma_t$ (g/l)	O <sub>2</sub> (ml/l)	PO <sub>4</sub> -P ( $\mu$ g at/l)
00	27.84	35.50	22.84		0.59
12	27.90	35.50	22.86		0.57
26	27.72	35.48	22.87		0.56
51	27.65	35.49	22.90		0.57
95	27.62	35.47	22.89		0.57
133	27.30	35.50	23.08		0.69
166	18.97	35.56	25.47		1.23
196	15.00	35.19	26.14		1.64
230	12.32	34.93	26.49		1.97
263	10.50	34.77	26.70		1.99
295	10.16	34.76	26.76		2.14
295	10.19	34.76	26.75		
359	9.87	34.76	26.81		2.07
452	8.76	34.66	26.91		2.28

## STATION 38

M/V Hugh M. Smith: Cruise 14, 2°03'S, 168°57'W, March 3, 1952.  
 Messenger time: first cast 0829 GCT, second cast 0910 GCT. Weather: 00,  
 cloud coverage not recorded. Wind: 080°, 14 kt. Sea: 3-5 ft. Wire  
 angle: 1/ first cast 45°, second cast 45°

## OBSERVED

DEPTH (m)	T (°C)	S (°/oo)	$\sigma_t$ (g/l)	O <sub>2</sub> (ml/l)	PO <sub>4</sub> -P ( $\mu$ g at/l)
02	27.15	35.26	22.89		0.70
13	27.18	35.26	22.88		0.71
23	27.08	35.26	22.91		0.65
55	27.00	35.28	22.95		0.65
107	27.11	35.54	23.11		0.74
161	18.45	35.51	25.57		1.31
213	12.28	34.93	26.50		1.70
264	11.24	34.80	26.59		2.04
317	10.69	34.76	26.66		2.21
373	10.10	34.73	26.74		2.16
441	9.60	34.68	26.79		2.25
554	8.50	34.64	26.93		2.44
689	6.40	34.55	27.17		2.68

1/ Underway to reduce wire angle.

## STATION 39

M/V Hugh M. Smith: Cruise 14, 1°02'S, 168°54'W, March 3, 1952.  
 Messenger time: 1901 GCT. Weather: 02, cloud coverage 1.  
 Wind: 090°, 14 kt. Sea: 3-5 ft. Wire angle: 1/ 25°

## OBSERVED

DEPTH (m)	T (°C)	S (°/oo)	$\sigma_t$ (g/l)	O <sub>2</sub> (ml/l)	PO <sub>4</sub> -P ( $\mu$ g at/l)
02	26.39	35.26	22.97		0.69
15	26.92	35.25	22.95		0.72
34	26.38	35.27	22.98		0.66
69	26.86	35.31	23.02		0.67
134	21.50	35.66	24.88		1.02
199	13.10	35.00	26.39		1.49
266	11.58	34.85	26.55		1.89
327	10.34	34.78	26.65		2.23
395	9.98	34.74	26.77		2.21
467	9.20	34.69	26.86		2.22
534	8.34	34.63	26.95		2.43
524	8.39	34.63	26.94		
657	6.32	34.56	27.19		2.61
790	5.41	34.53	27.28		2.68

1/ Underway to reduce wire angle.

## STATION 40

M/V Hugh M. Smith: Cruise 14, 0°01'N, 169°00'W, March 4, 1952.  
 Messenger time: 0455 GCT. Weather: 02, cloud coverage 1.  
 Wind: 090°, 16 kt. Sea: 3-5 ft. Wire angle: 1/ 45°

## OBSERVED

DEPTH (m)	T (°C)	S (°/oo)	$\sigma_t$ (g/l)	O <sub>2</sub> (ml/l)	PO <sub>4</sub> -P ( $\mu$ g at/l)
04	26.74	35.29	23.04		0.61
15	26.74	35.28	23.03		0.61
24	26.58	35.28	23.08		0.62
45	26.48	35.29	23.12		0.65
114	22.55	35.21	24.24		0.95
152	18.66	35.23	25.30		1.05
193 <sup>3/</sup>	15.24	35.10	26.01		1.27
195 <sup>-</sup>					
237	12.24	34.88	26.47		1.64
286	11.55	34.84	26.56		1.97
337	10.81	34.78	26.66		2.21
337	10.85	34.78	26.65		
441 <sup>4/</sup>	9.02	34.67	26.88		2.48
567 <sup>4/</sup>	7.69	34.60	27.03		2.58

2/1/ Underway to reduce wire angle.2/ Bottle pretripped, but was not recast.3/ Depth slightly unsure--bottle apparently slipped on wire.4/ Two bottom bottles had slid to end of wire when raised, but values look all right.

## STATION 41

M/V Hugh M. Smith: Cruise 14, 1°03'N, 169°00'W, March 4, 1952.  
 Messenger time: 1448 GCT. Weather: 00, cloud coverage not recorded.  
 Wind: 080°, 15 kt. Sea: 5-8 ft. Wire angle: 1/ 37°

## OBSERVED

DEPTH (m)	T (°C)	S (°/oo)	$\sigma_t$ (g/l)	O <sub>2</sub> (ml/l)	PO <sub>4</sub> -P ( $\mu$ g at/l)
04	26.46	35.16	23.03		0.63
15	26.43	35.17	23.03		0.61
30	26.44	35.16	23.04		0.60
59	26.13	35.19	23.14		0.66
113	25.04	35.16	23.47		0.79
167	16.12	34.97	25.72		1.20
222	12.02	34.85	26.49		1.71
275 <sup>2/</sup>	11.42	34.80	26.56		1.93
288 <sup>-</sup>					
331	10.25	34.73	26.72		2.13
392	9.88	34.70	26.75		2.28
451	9.07	34.66	26.86		2.35
451	9.12	34.66	26.85		
565	7.26	34.58	27.07		2.54
694	5.99	34.52	27.20		2.68

1/ Underway to reduce wire angle.2/ Bottle slipped on wire, depth unsure. Used 275 m. for drawing temperature curve, but may be wrong.

## STATION 42

M/V Hugh M. Smith: Cruise 14, 2°06'N, 168°57'W, March 5, 1952.  
 Messenger time: first cast 0043 GCT, second cast 0144 GCT, third  
 cast 0245 GCT. Weather: 02, cloud coverage 2. Wind: 090°, 16 kt.  
 Sea: 3-5 ft. Wire angle:  $\frac{1}{2}$  first cast 42°, second cast 32°, third  
 cast 35°

## OBSERVED

DEPTH (m)	T (°C)	S (°/oo)	$\sigma_t$ (g/l)	O <sub>2</sub> (ml/l)	PO <sub>4</sub> -P ( $\mu$ g at/l)
03	27.02	35.17	22.86		0.59
14	26.94	35.17	22.88		0.59
28	26.87	35.15	22.89		0.62
58	26.82	35.16	22.92		0.67
114	25.08	35.10	23.41		0.84
170	14.03	34.70	25.96		1.52
230	11.04	34.79	26.62		1.86
285	10.72	34.78	26.67		2.04
394	9.81	34.71	26.78		2.29
472	9.18	34.63	26.86		2.34
522	8.46	34.62	26.92		2.39
522	8.50	34.62	26.92		
663	6.74	34.55	27.12		2.83
815	5.22	34.53	27.30		2.85

$\frac{1}{2}$  Underway to reduce wire angle.

## STATION 43

M/V Hugh M. Smith: Cruise 14, 3°05'N, 169°00'W, March 5, 1952.  
 Messenger time: first cast 1140 GCT, second cast 1214 GCT.  
 Weather: 00, cloud coverage not recorded. Wind: 130°, 10 kt.  
 Sea: 3-5 ft. Wire angle: first cast 42°, second cast 54°

## OBSERVED

DEPTH (m)	T (°C)	S (°/oo)	$\sigma_t$ (g/l)	O <sub>2</sub> (ml/l)	PO <sub>4</sub> -P ( $\mu$ g at/l)
00	27.16	35.11	22.77		0.63
13	27.18	35.10	22.76		0.58
27	27.16	35.12	22.78		0.61
55	27.08	35.12	22.81		0.64
99	27.03	35.14	22.83		0.68
137	26.81	35.16	22.92		0.70
173	16.07	34.63	25.51		1.32
173					1.38
208	11.20	34.56	26.42		2.03
225	10.92	34.61	26.51		1.97
263	9.91	34.63	26.70		2.27
304	9.73	34.70	26.78		2.38
304	9.76	34.70	26.77		
403	8.70	34.63	26.89		2.41
527	7.56	34.59	27.04		2.56



## STATION 44

M/V Hugh M. Smith: Cruise 14, 4°06'N, 168°57'W, March 5, 1952.  
 Messenger time: 2224 GCT. Weather: 02, cloud coverage 9.  
 Wind: 040°, 19 kt. Sea: 5-8 ft. Wire angle: 28°

## OBSERVED

DEPTH (m)	T (°C)	S (°/oo)	$\sigma_t$ (g/l)	O <sub>2</sub> (ml/l)	PO <sub>4</sub> -P ( $\mu$ g at/l)
00	27.72	35.05	22.54		0.51
13	27.74	35.07	22.55		0.53
31	27.69	35.07	22.57		0.53
66	27.65	35.09	22.60		0.57
132	26.90	35.12	22.86		0.65
198	13.30	34.59	26.03		1.83
264	9.87	34.63	26.70		2.38
327	9.10	34.60	26.81		2.34
395	8.51	34.60	26.90		2.37
469	7.94	34.56	26.96		2.48
538	7.39	34.55	27.03		2.90
538	7.44	34.55	27.02		
678	6.22	34.50	27.15		2.90
831	5.36	34.51	27.27		2.89

## STATION 45

M/V Hugh M. Smith: Cruise 14, 4°59'N, 168°56'W, March 6, 1952.  
 Messenger time: 0611 GCT. Weather: 02, cloud coverage 9.  
 Wind: 050°, 18 kt. Sea: 5-8 ft. Wire angle: 25°

## OBSERVED

DEPTH (m)	T (°C)	S (°/oo)	$\sigma_t$ (g/l)	O <sub>2</sub> (ml/l)	PO <sub>4</sub> -P ( $\mu$ g at/l)
01	27.91	34.85	22.33		0.49
09	27.94	34.85	22.32		0.49
26	27.91	34.85	22.33		0.54
53	28.01	35.04	22.44		0.55
105	26.91	35.07	22.82		0.59
157	20.84	34.88	24.46		0.83
209	11.46	34.54	26.35		2.04
261	9.30	34.66	26.82		2.10
314	8.90	34.69	26.91		2.26
368	8.46	34.60	26.91		2.39
417	8.02	34.60	26.98		2.39
417	8.07	34.60	26.97		
525	7.28	34.60	27.09		2.80
630	6.52	34.54	27.14		2.82

## STATION 46

M/V Hugh M. Smith: Cruise 14, 5°52'N, 169°00'W, March 6, 1952.  
 Messenger time: 1514 GCT. Weather: 00, cloud coverage not recorded.  
 Wind: 080°, 19 kt. Sea: 5-8 ft. Wire angle: 08°

## OBSERVED

DEPTH (m)	T (°C)	S (°/oo)	$\sigma_t$ (g/l)	O <sub>2</sub> (ml/l)	PO <sub>4</sub> -P ( $\mu\text{g at/l}$ )
00	27.92	34.97	22.42		0.54
11	27.94	34.98	22.42		0.49
31	27.91	34.96	22.41		0.53
60	27.93	34.97	22.42		0.55
116	23.62	34.91	23.71		0.64
177	15.08	34.59	25.66		1.63
235	10.48	34.61	26.58		2.51
293	9.40	34.63	26.78		2.56
351	8.76	34.60	26.86		2.40
409	8.37	34.58	26.91		2.47
462	7.95	34.57	26.97		2.60
462	7.99	34.57	26.96		
578	7.12	34.53	27.05		2.88
690	6.08	34.51	27.18		3.07

## STATION 47

M/V Hugh M. Smith: Cruise 14, 6°58'N, 168°54'W, March 7, 1952.  
 Messenger time: 0442 GCT. Weather: 21, cloud coverage 10.  
 Wind: 080°, 16 kt. Sea: 8-12 ft. Wire angle: 00°

## OBSERVED

DEPTH (m)	T (°C)	S (°/oo)	$\sigma_t$ (g/l)	O <sub>2</sub> (ml/l)	PO <sub>4</sub> -P ( $\mu\text{g at/l}$ )
03	27.85	34.90	22.39		0.50
13	27.88	34.88	22.36		0.47
32	27.89	34.97	22.43		0.49
63	27.88	34.95	22.42		0.53
122	23.26	34.96	23.85		0.67
180	14.33	34.63	25.85		1.67
238	10.58	34.69	26.63		2.54
298	9.52	34.69	26.81		2.59
357	8.92	34.66	26.89		2.67
417	8.56	34.67	26.95		2.70
471	8.17	34.61	26.96		2.75
471	8.21	34.61	26.95		
588	7.40	34.55	27.03		2.96
701	6.55	34.52	27.12		3.01

