

EX LIBRIS

MINING DEPT

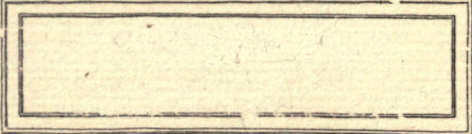

9 1 eardasley
S.F. Mar 08

MINE TIMBERING

MINE TIMBERING

BY

WILBUR E. SANDERS

BERNARD MACDONALD

NORMAN W. PARLEE

AND OTHERS



UNIV. OF
CALIFORNIA

NEW YORK AND LONDON
HILL PUBLISHING COMPANY

1907

TN 289
S2
cop. 2
MINING DEPT.

COPYRIGHT, 1907, BY HILL PUBLISHING Co.
ENTERED AT STATIONERS' HALL

mining dept

TO THE
MINING DEPT.

The Plimpton Press Norwood Mass. U.S.A.

PREFACE

THIS book is a collection of articles that have previously been printed in the *Engineering and Mining Journal*, *The Mineral Industry*, and the transactions of various societies, the source being stated in a foot-note to each article. The article by Mr. MacDonald was published originally in the *Proceedings of the Canadian Mining Institute*, and that by Mr. Parlee in the *Proceedings of the Canadian Society of Civil Engineers*. Permission to make this republication has been courteously granted by the Secretaries of both those societies, and the respective authors have coöperated with suggestions and in the reading of proof. The last part of the book is made up chiefly of articles that have appeared in the *Engineering and Mining Journal* during the last two or three years. In the absence of any treatise on this important subject, which in the hand-books and text-books on mining is dealt with only in a superficial way, it has appeared worth while to make the present collection, which is offered not as a complete treatise on the subject, but rather as a series of essays which go fully into many important details. It is hoped that a thorough and systematic treatise on mine timbering will soon be written.

EDITOR.

TABLE OF CONTENTS

	PAGES
PREFACE	v
LIST OF ILLUSTRATIONS	ix
MINE TIMBERING, BY WILBUR E. SANDERS	1-52
<p>Timbering of shafts, stations, and levels, 7. Shafts, 7. Inclined shafts, 10. Stations for inclines, 13. Alinement of incline sets, 14. Vertical shafts, 16. Cribbed shaft timbering, 16. Halved framing for shaft sets, 18. Square-set shaft timbers, 20. One-compartment shafts, 20. Locating shaft sets, 22. Alinement of vertical shafts, 24. Repairing shafts 25. Timbering shafts in loose ground, 26. Timbering shafts in running ground, 26. Two-compartment shafts, 28. Three-compartment shafts, 29. Four-compartment shafts, 31. Ladders, 34. Shaft station sets, 35. Stations, 35. Levels, 36. Timbering levels in loose ground, 39. Timbering of the working places in a mine, 41. Posts, 41. Cribs, 41. Stulls, 42. Penning, 45. Square sets in stoping, 46. Reinforcing sets, 49. Ore chutes, 49. Waste filling, 50. Methods of framing, 50.</p>	
MINE TIMBERING BY THE SQUARE-SET SYSTEM AT ROSSLAND, B.C., BY BERNARD MACDONALD	53-71
<p>Historical, 55. Vein characteristics at Rossland, 56. Preliminary work, 56. Sill-floor construction, 57. Timbers and methods used after sill floor is laid, 60. Per tonnage cost of square-set timbering, 64. Cost data per square set, hand framed, 64. Incidental costs, 67. Limitations of the square set, 67. Reinforcement methods, 68. Angle bracing, 68. Cribbing, 68. Bulkheading, 70. Filling, 70. General remarks, 70.</p>	
METHODS OF MINING AND TIMBERING IN LARGE OREBODIES IN BRITISH COLUMBIA AND MICHIGAN, BY NORMAN W. PAR- LEE	73-102
<p>Le Roi mine, Rossland, B.C., 76. Old Ironsides mine, Phenix, B.C., 85. Baltic mine, Baltic, Mich., 89. Atlantic</p>	

	PAGES
mine, Atlantic, Mich., 92. Barnum mine, Ishpeming, Mich., 93. Section 16 mine, Ishpeming, Mich., 94. Soft Ore Hematite mine, Ishpeming, Mich., 96. Queen mine, Negaunee, Mich., 99.	
MINE TIMBERING IN SECTION 16 OF THE LAKE SUPERIOR MINING COMPANY, MICHIGAN, BY C. ST. G. CAMPBELL	103-120
Shaft timbering, 108. Drift sets, 110. Square sets, 112. Stulls, 112. Timber pillars, or cribs, 114. Docks, 115. Chutes, 117. Staging, 118. Ladders and sollars, 119. Miscellaneous, 119.	
THE FRAMING OF RECTANGULAR SHAFT SETS, BY WILBUR E. SANDERS	123-130
SQUARE-SET PRACTICE AT BINGHAM, UTAH, BY LOUIS S. CATES	131-139
SQUARE-SET TIMBERING AT BINGHAM, UTAH, BY CLAUDE T. RICE	140-143
Mining methods, 140. The square-set system, 141. Peculiarities of the Bingham practice, 142. Criticism of the system, 143.	
MINE TIMBERING AT LAKE SUPERIOR, BY W. R. CRANE	144-149
Timbering in shafts, 145. Concrete lining, 147. Timbering in drifts and stopes, 147.	
TIMBER AND TIMBERING IN THE CŒUR D'ALENE, BY J. H. BATCHELLER	150-169
TIMBERING AT THE CHILLAGOE MINES, QUEENSLAND, BY T. J. GREENWAY	170-174
TIMBERING IN TASMANIA, BY MARK IRELAND	175-176
INDEX	177-179

LIST OF ILLUSTRATIONS

FIGURES	PAGES
1-5. Weight pressure on timbers	5-6
6. Three-piece level set	8
7. Four-piece level set	8
8-10. Three-compartment shaft set	9-11
11. Details of the four-piece set	11
12-13. Station for inclined shaft	12-13
14-16. Straight-edge and plumb line	14
17-20. Ladders and hanging bolts	15
21-21 A. Cribbed shaft timbering with poles	16
22-22 A. Cribbed shaft timbering with planks	16
23. Cribbed shaft timbering with framed set	17
24-25. Halved framing for shaft sets	19
26. Timbering of a one-compartment shaft. Details	21
27. Timbering of a one-compartment shaft. Perspective	22
28. Method of supporting shaft sets	23
29. Lining for shafts in loose ground	26
30. Spiling in running ground	28
31. Framing of three-compartment shaft. Perspective	29
32. Framing of single-width four-compartment shaft	31
33. Framing of double-width four-compartment shaft. Plan and details	32
34. Framing of double-width four-compartment shaft. Perspective	33
35. Single-piece set	36
36. Two-piece set	37
37-38. Three-piece set	38
39. Four-piece set	39
40. Spiling in loose ground	40
41. Post and head board	41
42. Crib	41
43. Crib with waste filling	42
44. Stull	43
45. Stull and false stull	44
46. Double-stull method	44
47. Saddle back and arch	45
48. Saddle back	45

FIGURES	PAGES
49. Penning	46
50. Angle of underlie of stulls	47
51. Square sets in stoping	48
52. Anaconda method	50
53. Eureka method	51
54. Burlingame method	51
55. Richmond method	51
56. Anaconda method of framing. Details	52
57. Square-set timbering at Rossland, B.C.	58
58-59. Working floors at Rossland, B.C.	60-61
60. Square-set timbering at Rossland, B.C. Details	66
61-63. Square-set timbering at Rossland, B.C.	69
64-66. Stull timbering, Le Roi mine	77
67. Mud-sills and ties, Le Roi mine	79
68. Details of square sets, Le Roi mine	80
69. Square sets in position, Le Roi mine	81
70-72. Views of chute, Le Roi mine	82
73. General scheme of stope, Le Roi mine	84
74-75. Lagging arrangement, Old Ironsides mine	87
76-77. Chute arrangement, Old Ironsides mine	88
78-79. Method of walling up, Baltic mine	90
80. Longitudinal section of stope, Baltic mine	91
81. Stull timbering, Atlantic mine	92
82. Stopes and pillars	94
83. Filling system, Section 16 mine	95
84. Caving system, Soft Ore Hematite mine	97
85-86. Stopes and pillars, Queen mine	100
87. Section 16 Mine. Projection of 2d and 10th levels	106
88. Horizontal section through shaft, Section 16 mine	109
89. Side elevation of drift set, Section 16 mine	110
90. End view of drift set, Section 16 mine	111
91. Raker, Section 16 mine	112
92-93. Stulls, Section 16 mine	113
94. Method of setting up machines	114
95. Docks	116
96. Mills	117
97. A typical mill chute	118
98. Frame of rectangular shaft set, assembled	124
99. Laying out and framing rectangular shaft set	127
100-101. Square-set timbering at Bingham, Utah	132
102. Transverse section of stope	133
103. Transverse section of stope	135
104. Short sets	136
105. Butt cap and ground post	138
106. Details of square-set timbering	141
107. Shaft timbering. Plan and section	145
108. Level timbering and square setting	146

LIST OF ILLUSTRATIONS

FIGURES		PAGES
109.	Forms of square-set joints	148
110-115.	Square-set timbers	151-152
116-117.	Square-set stope	153
118.	Battered and straight tunnel sets	154
119.	Tunnel-set timbers	155
120.	Two-compartment shaft	156
121.	Four-compartment shaft	157
122.	Angle braces	158
123.	Standard stope set	159
124.	Double drift sets	160
125.	Two-compartment shaft station	165
126.	Four-compartment shaft set	166
127-131.	Details of framing	167
132-133.	Stull stope	168
134-137.	Templates and posts	170
138.	Caps or stretchers	171
139.	Miter box	172
140.	Method of framing posts, caps, and stretchers	173

MINE TIMBERING

·BY

WILBUR E. SANDERS

MINE TIMBERING ¹

BY WILBUR E. SANDERS

IN this necessarily brief article the systems of timbering dealt with are those in use among the mines of the mountainous regions of western United States. This qualification, of itself, requires no apology; for the cosmopolitan character of our miners — managers and engineers, superintendents and foremen — and their shrewd keenness in devising ways to meet the problems presented in underground workings, in selecting means peculiarly adapted to the end in view, and in improving upon well-known methods already in vogue, have placed the science of supporting mine excavations by timbers, as developed by them, far in advance of that in use among the older and less progressive mining communities. This monograph does not include the methods used in coal mining in the East, or that in use in the copper and soft iron ore deposits of Michigan and Minnesota; nor does it treat of wood and iron cribbing for round shafts, or of iron supports now used in many European mines, nor of timbering and metal supports used in large tunnels.

The mines operated under these methods present every known characteristic of lode formation. The veins and ore deposits lie at all angles of inclination or *dip*; they are of all shapes and sizes, from the small seam to immense masses hundreds of feet in width, and of all lengths; while the materials comprising them and their country formations vary in texture from rock of strength sufficient to overlie considerable excavations without extraneous support, to the soft ground which requires not only immense quantities of timber and waste filling to carry the workings safely, but an eternal vigilance upon the part of those conducting the operations.

During preliminary work it is important to explore and develop the orebodies in the surest and least expensive ways, and,

¹ From *The Mineral Industry*, 1899, Vol. 8.

except in the case of prospecting hidden or blind deposits, by means of bore-holes from the surface downward, metal mines are tested and all are exploited during their earlier stages by shafts sunk or adit-levels driven in and with the ores. This latter is an axiom in mining during this period of development, and should be invariably followed where possible. When once the ores have been opened up so that an estimate may be made as to their extent and general characteristics, more expensive works necessary to prepare the mine for the larger operations of economic ore extraction may be safely entered upon. It sometimes happens that the required information as to orebodies beneath the surface of a mining claim is sufficiently answered in and by the workings of adjoining properties to make preliminary prospecting of the deposits unnecessary; then systematic plans for operating on a large scale may be properly inaugurated.

It is not the province of this article to touch upon methods of mining in use above ground, whether by openwork, hydraulic mining, or by other processes, but rather to deal with the support of underground excavations by the use of timbers, and the details of mining therewith connected. Nor is it intended to explain methods technically foreign to the subject, although such will be touched upon when used as adjuncts to systems of timbering, as waste filling, etc. In the figures drawn to illustrate the article, sizes of timber most frequently used have been arbitrarily taken for convenience. The figures giving dimensions are working drawings showing the methods of framing, as explained, and can easily be applied to frames and timbers of any desired dimensions.

In developing and exploiting mines the miner should remember that unnecessarily large openings for levels, shafts, and other similar workings, mean not alone the breaking down and transporting of needless quantities of material, but also the added expense of keeping in repair larger passageways than are necessary, an item of considerable importance in heavy or creeping ground. On the other hand, the larger excavations are relatively the easier and cheaper to drive. The rule should be that the size of workings must be ample to carry out their purposes properly, but not larger than is necessary for economy in operation.

It often happens that conditions, local or otherwise, are such that the strongest timbering fails to withstand the pressure to which it is subjected, and other means of support must be em-

ployed. In exceptional cases large excavations may be supported with little or no timbering, but usually waste filling must be extensively used as an adjunct to timbering if the mine is to be kept open. Swelling or "creeping" ground, resulting from the exposure of certain rocks and clays to the air, whereby they expand with a force no timbering can resist, demands prompt attention that the timbers may be relieved from abnormal strain. This is done by making use of an open lining of lagging, through the interstices of which sufficient material may be removed to relieve the unusual pressure upon the frames; a process that is continued as long as the conditions demand. The above scheme is employed at the Ontario mine, Park City, Utah, and in the Never Sweat mine, Butte, Mont., where a system of narrow "square sets," with open lagging, placed outside of the timbers of the large three-compartment working shafts, has been successfully employed to meet just such conditions in swelling ground.

There are certain established principles connected with the use and framing of mine timbers that should be borne in mind. Pressure is best resisted in line with the grain of the wood rather than across the grain, which may be made clear by the following explanation:

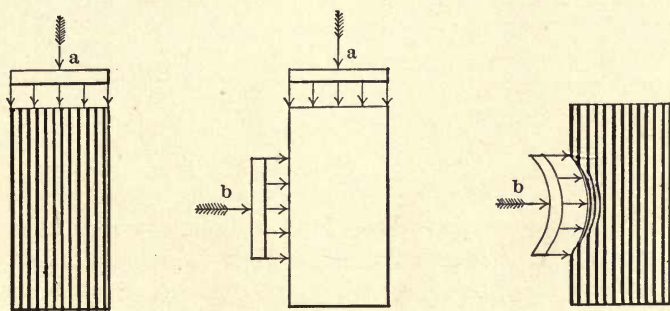

FIGS. 1-3. — WEIGHT PRESSURE ON TIMBERS.

Let Fig. 2 be a section of timber supporting upon end and side the weight pressures represented by the arrows *a* and *b*; *a* acting in line with the grain of the piece, *b* at right angles to the grain. As shown in Fig. 1 each individual grain or fiber of which the block is composed resists the pressure *a* by the strength of the combined fibers of the timber, or in other words by the full strength of the timber itself. On the other hand, Fig. 3, the pressure *b* acting across the grain is resisted by the power which binds

Therefore, for resisting pressure from two or more directions the framing shown in Fig. 4 is not applicable.

The only satisfactory remedy for this inherent weakness of square-shoulder framing is to make use of the mitered joint or beveled hitch, as shown in Fig. 5. In this method, because of the support afforded a timber by the miter of this joint, the pressure from any of the directions *a*, *b*, *c*, and *d* is resisted by the strength of the full cross-section of the piece against which the force acts. However, as shown in the piece *C*, the simple miter is not in itself sufficient to sustain any considerable thrust without a tendency to wedge apart the timbers *B* and *D*, and thus destroy the set. Without doubt the simplest and strongest joint obtainable is some combination of the square-shouldered tenon with the miter or beveled hitch. This combination is shown in the joints supporting the piece *A*. Here the full strength of the timber is obtained, with no tendency to split or slip, and weight up to near the point of crushing only serves to bind the set more firmly together.

Heavy ground is supported by the heavier timbers; by sets placed near together; and by sets strengthened by reinforcing sets of timbers.

Round timbers are stronger than square-sawed pieces, in which the grain of the wood has been cut and weakened by the saw. Used in the mine, round timbers are less easy to handle than are the squared; they are less easy to aline properly, and it is impossible to reinforce satisfactorily sets framed from such timbers by the usual false sets or pieces. The bark should invariably be removed from round timbers, as it collects moisture and fungus, and thus hastens the decay of the wood. It also prevents the pieces from becoming properly seasoned before they enter the mine.

TIMBERING OF SHAFTS, STATIONS, AND LEVELS

SHAFTS. — Shafts are of two kinds, vertical and inclined. The former is more frequently used in large operations, where speed and convenience in hoisting are the prime necessity — particularly in connection with the more steeply inclined deposits, and with flat ones and pockets lying entirely beneath the surface.

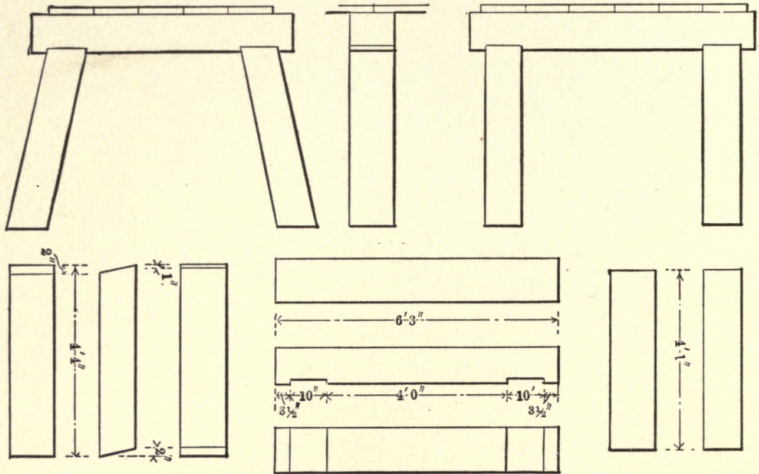

FIG. 6. — THREE-PIECE LEVEL SET.

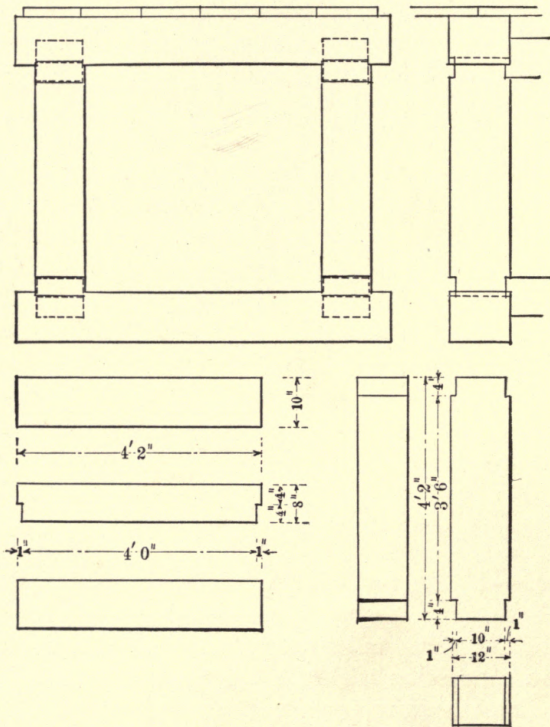

FIG. 7. — FOUR-PIECE LEVEL SET.

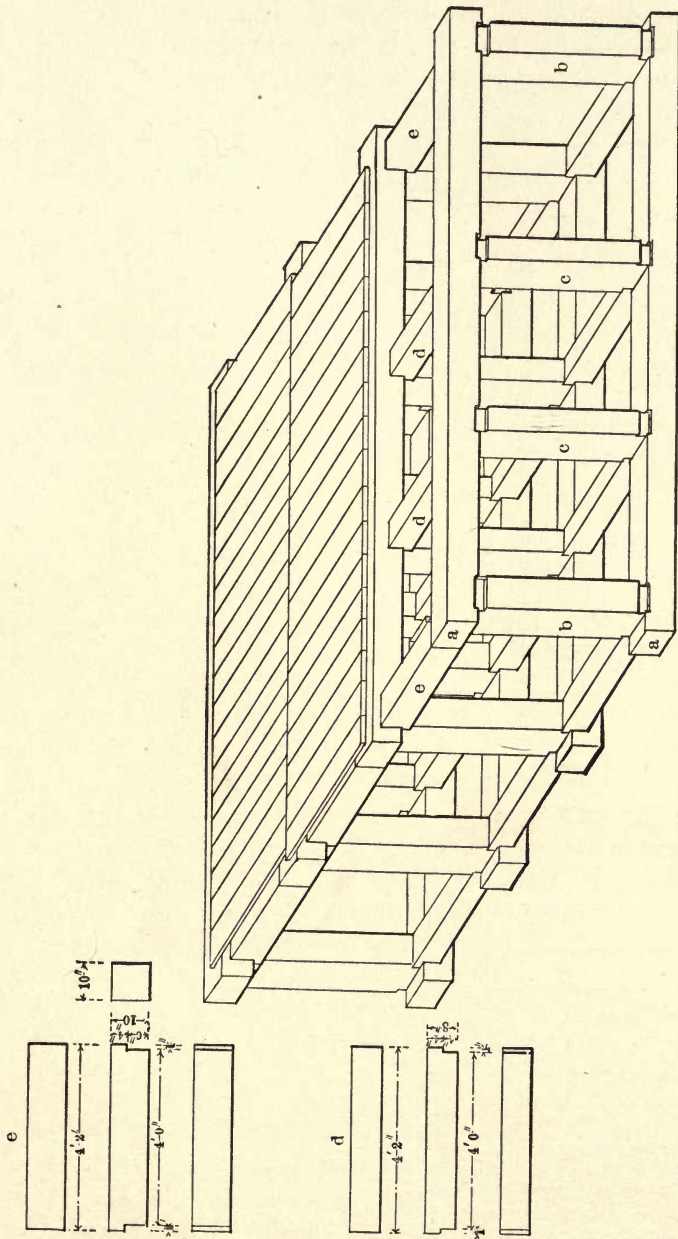

FIG. 8. — THREE-COMPARTMENT SHAFT SET.

The usual size for single-compartment shafts, and for the hoisting compartments of the larger shafts in metal mining, is from 4 to 6 ft. in the clear of the timbers; the compartment used to carry water-columns, air- and steam-pipes, and ladders, is frequently made larger in cross-section than the working compartments. The expense of sinking shafts and of keeping them in repair in average ground increases rapidly beyond a certain size; it is therefore considered good practice to make the shafts as small as possible, keeping in view the work to be carried on through them.

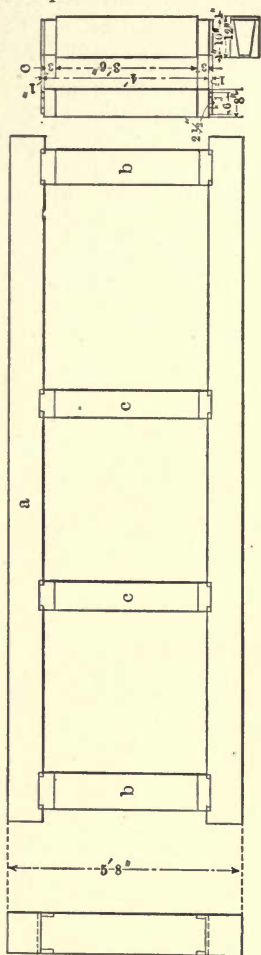

FIG. 9. — THREE-COMPARTMENT SHAFT SET.

Inclined Shafts. — Inclined shafts are used largely during the preliminary stages of development in veins, and other outcropping deposits that dip below the horizontal at angles too small to allow of the economical use of vertical shafts. Similar methods of timbering both classes of shafts are in use, although at times the timbering of inclined shafts approaches more nearly to that employed in supporting the level workings; as when application is made of the three-piece and four-piece level sets to inclines (Figs. 6 and 7). The single stull piece, with head board, is often used in the mountains when the hanging wall or top rock is of such strength as to require little support.

When the three-piece level set is employed the cap is usually lengthened, and the top of each post fits into gains cut near the ends of the cap. Where a sill piece is desirable the sill is framed in the same manner as the cap, and the posts act as dividers. (See Fig. 7.) In such use technically the posts become end

plates, the cap and sill side plates, while posts when used are placed lengthwise of the shaft as distance pieces to separate the sets. (See Fig. 8.)

A two-compartment shaft is constructed by placing a third post or girt in position at or near the center of the set in much the same manner as are located the end posts or plates.

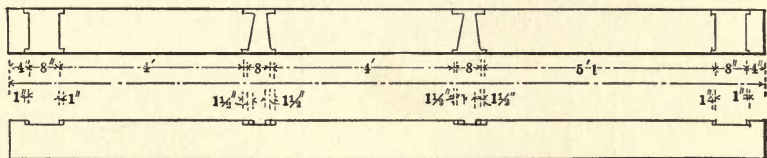

FIG. 10. — THREE-COMPARTMENT SHAFT SET.

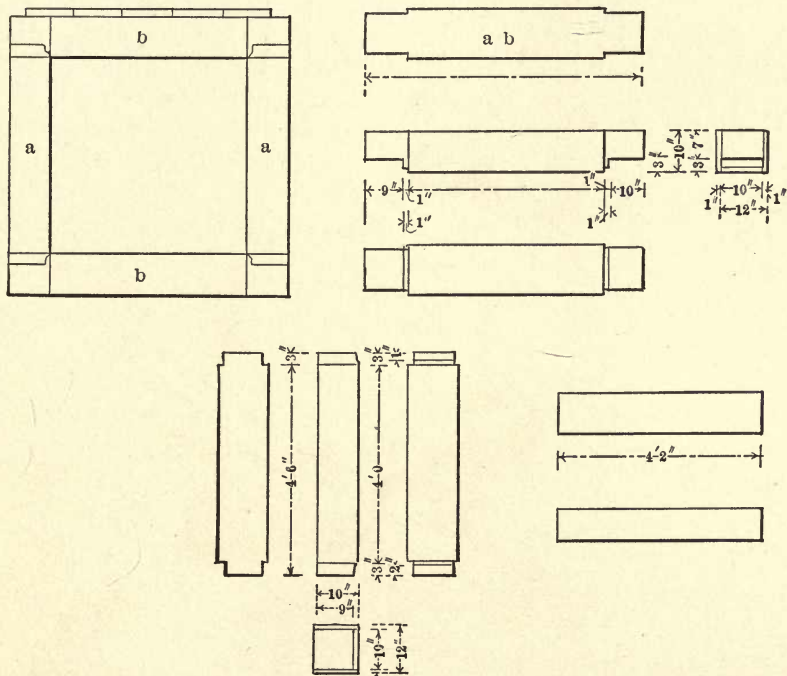

FIG. 11. — DETAILS OF THE FOUR-PIECE SET.

The three-compartment shaft is similarly constructed by locating two such girts at their proper position, the tenons of the girts being V-shaped. (See Figs. 8, 9, and 10.) Behind or back of the side plates, and in line with the end plates and girts, the

set is tightly blocked and wedged in place. Pole or plank lagging is used where it is necessary to prevent falls of loose rock from the walls and sides of the shaft. Skip-ways are carried by the sill piece or bottom side plate. Guides also are attached to the end plates and center girts when safety devices are used upon the ore-skips.

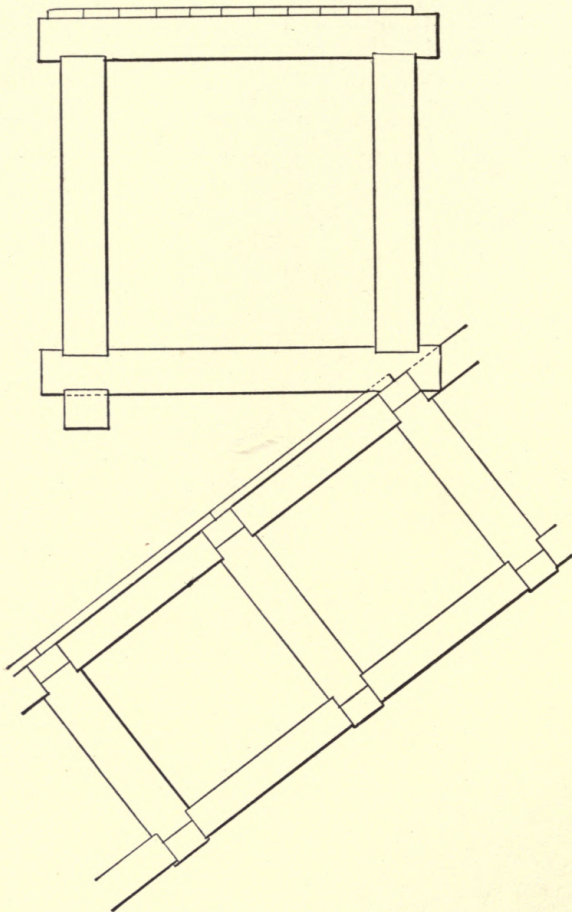

FIG. 12. — STATION FOR INCLINED SHAFT.

Other methods of framing the four-piece set, as applied to the inclined shaft, differ from the above framing in minor details, and at the same time allow of the use of the full width of the

shaft. (See Fig. 11.) The halved system of framing, as explained under vertical shafts, is rarely used for the inclines, and then only when posts are employed to form the complete square shaft set.

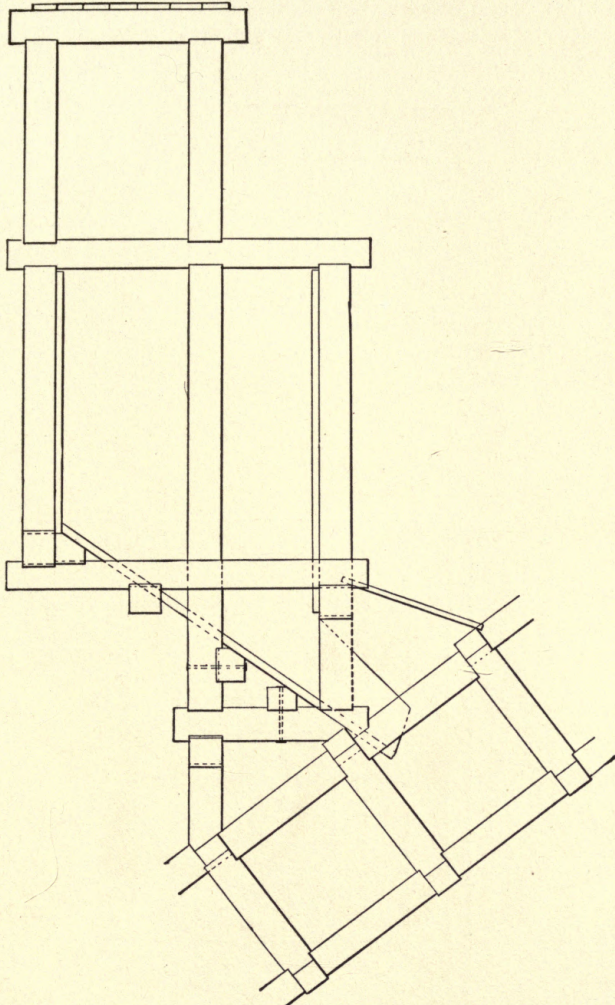

FIG. 13. — STATION FOR INCLINED SHAFT.

Stations for Inclines. — The stations constructed for inclined shafts are of two kinds, one being so arranged that the ore cars dump directly into the hoisting skip, held in position just beneath (Fig. 12), while in the other a 25- to 75-ton ore bin is placed

beneath the station and above the shaft, from which bin the ore is drawn into the skip for hoisting to the surface at intervals. This station, while requiring more excavating to construct, is by far the most economical in the end, as the skip can be run entirely independently of the trammers or carmen. (See Fig. 13.)

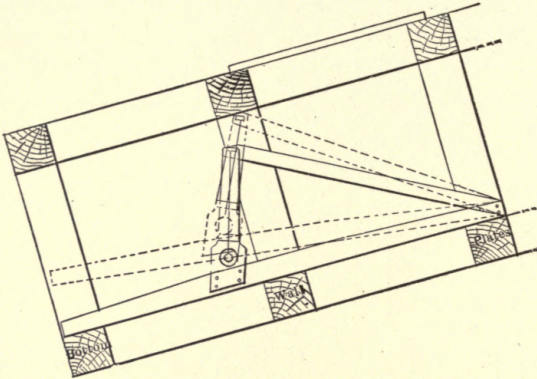
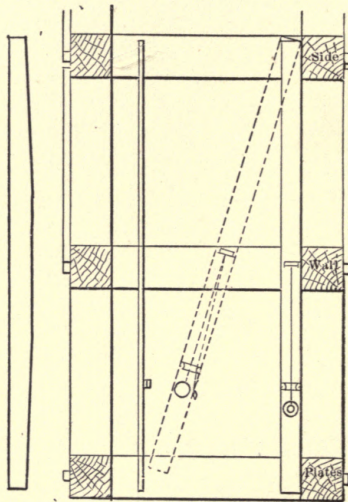

FIG. 14. — STRAIGHT-EDGE AND PLUMB-LINE.



FIGS. 15 AND 16. — STRAIGHT-EDGE AND PLUMB-LINE.

Alinement of Incline Sets. — Probably the simplest method of alining the side plates of inclined-shaft sets, in order to get them in line one with another, is by the use of the combined straight-edge and plumb-bob.

A straight-edge is made of a length greater by a foot or so than the distance between two sets. From the side opposite the true edge is built up a frame, one piece of which is so set that a plumb-line attached at its upper end will hang vertically along a fixed line, marked upon it, when the straight-edge coincides with the true inclination of the shaft, and at the same time simultaneously rests upon three bottom plates. To prevent the plumb-line from swinging too freely it is confined at its lower end within comparatively small limits by a cleat attached to the upright piece. (See Fig. 14.) The straight-edge alone is used to locate

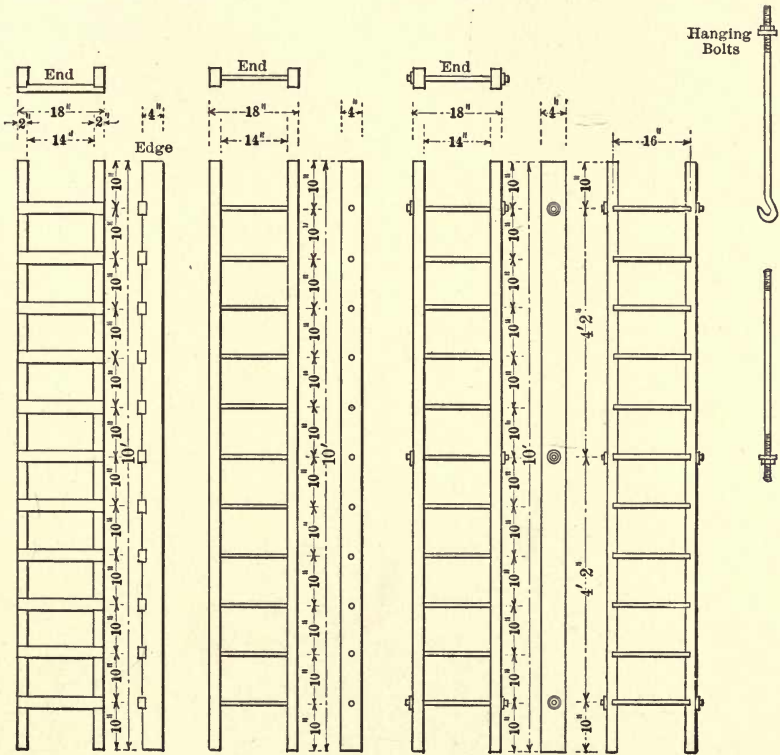

FIGS. 17-20. — LADDERS AND HANGING BOLTS.

the end plates evenly in line with each other. (Fig. 15.) When the sets are placed they are bound in position by hanging hooks or bolts (Fig. 20), as explained under vertical shafts, and when so held are blocked and wedged firmly in place; the straight-edge,

as above described, being employed to locate the sets in their true position during this operation.

Vertical Shafts. — The timbering of shafts varies according to the nature of the ground and the size of the shaft. Shafts sunk in some localities require little if any timbering, while in other places they are supported only by huge timbers that have been framed with the utmost precision.

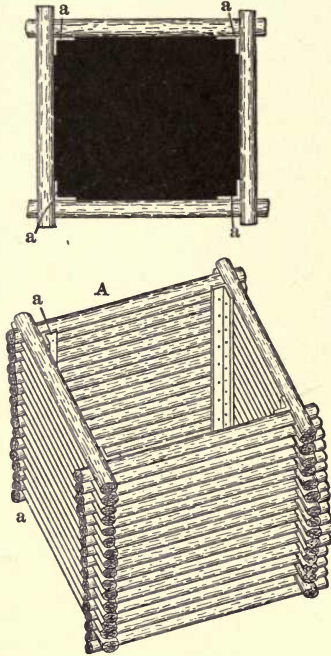

FIGS. 21 AND 21A. — CRIBBED SHAFT TIMBERING WITH POLES.

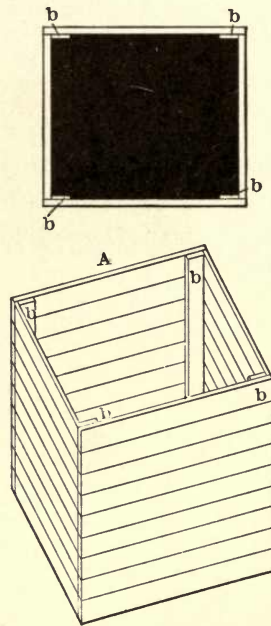

FIGS. 22 AND 22A. — CRIBBED SHAFT TIMBERING WITH PLANKS.

Cribbed Shaft Timbering. — In small shafts usually some form of cribbing is used. This system of shaft timbering is the simplest and often the cheapest in use, but it becomes cumbersome and expensive in large shafts. As usually employed it requires little framing, is easy to place, to repair or renew, and to keep properly alined, and its use enables the timbering to be kept even with the bottom of the shaft in sinking, if that be necessary.

The simplest form of cribbing is that of poles, cut to required lengths and placed in pairs across each other, either from above or below. Located in this manner it forms an openwork lining to the shaft. Strips *aa* nailed to the poles upon the inside corners keep the cribbing in position. (See Figs. 21 and 21A.)

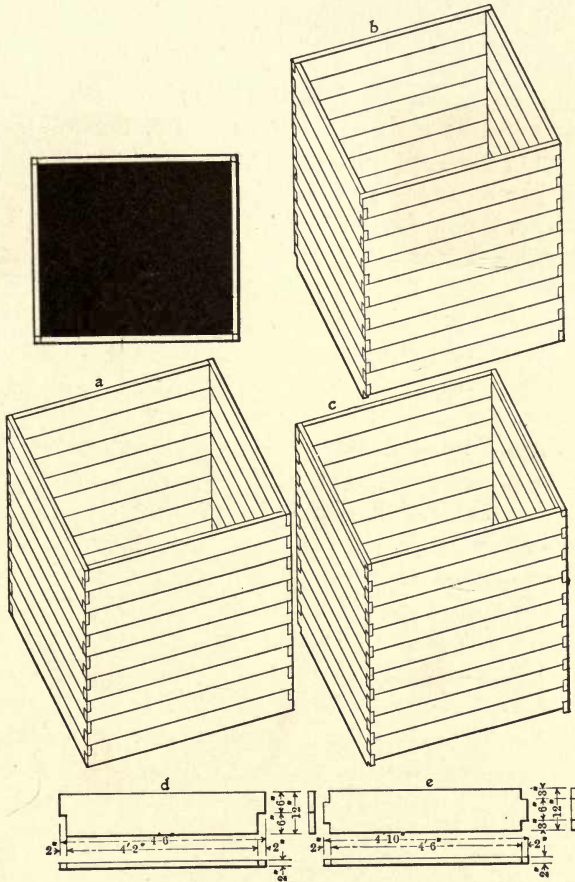

FIG. 23. — CRIBBED SHAFT TIMBERING WITH FRAMED SET.

Cribbing is also formed from sawed timbers of various dimensions, the most simple method being that in which planks of the required lengths are placed around the shaft, upon edge, and resting upon similar sets below or supporting similar

sets above. These sets are made to resist the outside pressure, usually, by so placing the two shorter or end pieces that they will hold apart the two longer side pieces, the former in their turn being held in their position by corner strips *b* within, and nailed up and down the shaft to the side pieces. (See Figs. 22 and 22A.)

While the method of timbering is extremely simple it is unsatisfactory, and good mining practice makes use of the framed set as being stronger and in every way better. The basis of this system is some form of the tenon and mortise, whereby the ends of the two timbers forming a joint are framed with both a tenon and what might be called an open mortise, the mortise of one piece engaging the tenon of the other and *vice versa*, to the end that each piece supports or keys its mate in place. See Fig. 23, *a*, *b*, and *c*, which show the more simple forms of this method of cribbing, the latter *c* being excellent for the reason that it causes the edges of the planks on the sides to break joint with the edges of the end planks in a way to stiffen the shaft and prevent the sets from moving horizontally one upon another. The methods of framing planks for these styles of cribbing are shown in Fig. 23, *d* and *e*.

Halved Framing for Shaft Sets. — A development of the tenon and mortise framing of joints is of almost universal application in advanced methods of supporting vertical shafts. This method is applied to the cribbed system as shown in Fig. 24, *a*, *A*, *b*, and *B*. The method of framing the pieces for openwork cribbing is shown in Fig. 24, *a*, and for tight cribbing, Fig. 24, *b*.

Fig. 24 *B* also shows the framing of the opening from the shaft to the levels. False timbers or struts are used temporarily to hold the sides of the shaft intact while this opening is being framed into the level, or the framing can be placed before the planks are removed from the cribbing. A stronger and more satisfactory frame, however, is obtained by the combined beveled hitch and halved joint. The most satisfactory use of this combination is that in which the top and bottom of the side plates are made to break joint with top and bottom of the end plates. (See Fig. 25.) Details of this framing are given in Fig. 25, *a* and *b*, while the method of placing the timbers is shown in the isometric perspectives *A* and *B*.

Compartments are formed by cutting the side plates to receive a center girt that is framed very similarly to the end plates.

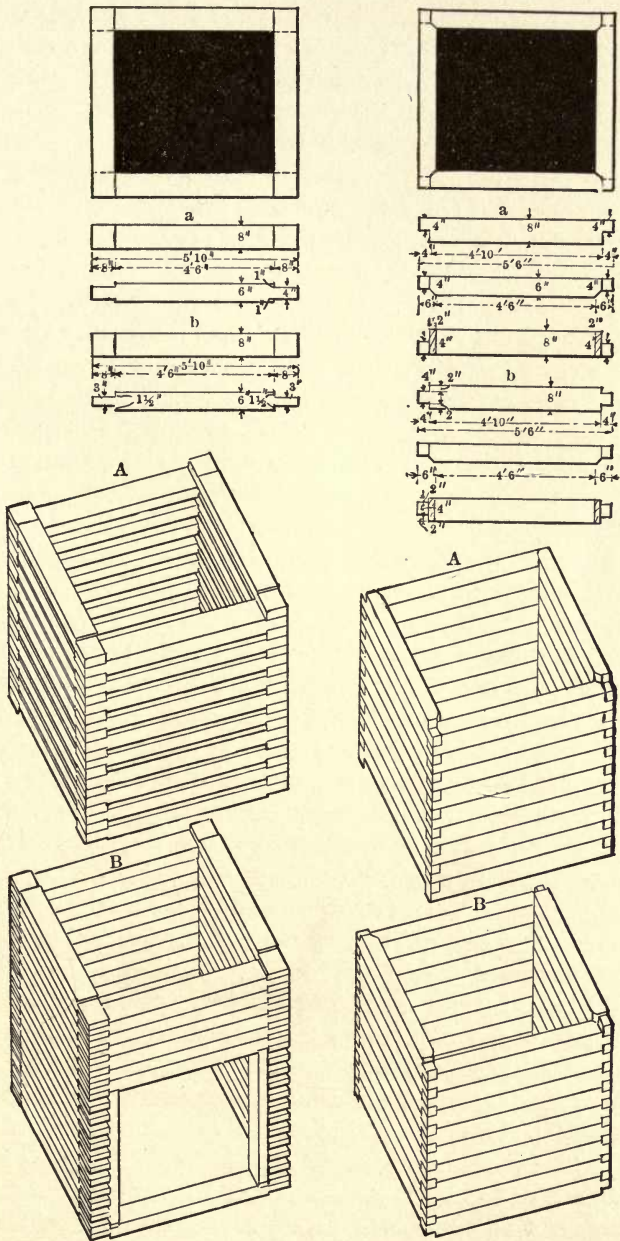

FIGS. 24 AND 25. — HALVED FRAMING FOR SHAFT SETS.

The tight cribbing has been used for large shafts in heavy ground. On the Comstock lode, Virginia City, Nev., several of the important shafts were timbered with a solid cribbing of 14-in. pieces.

Square-Set Shaft Timbers. — In the square-set system, as applied to the timbering of vertical shafts, the heavier timbers of a cross-section of 6 in. and upward are employed. A set consists of the side and end pieces, with posts used to separate the horizontal frames. In the larger shafts divisional timbers, called girts, are used to separate the compartments. The side and end pieces are called wall plates, for the reason that they frame the sides or walls of the shaft. The longer pair of plates are designated as side wall plates — usually called side plates — and the shorter pair as end wall plates, or end plates. Shafts of a single compartment are characterized as one-compartment shafts; and those which are divided by inner struts or girts into two, three, and four divisions, as two-, three-, and four-compartment shafts. It is doubtful if shafts larger than with four compartments can be successfully operated in deep mining, unless in exceptional cases. The framing of the various sized shafts is very similar, differing only in details that will be explained later.

One-Compartment Shafts. — The timbering of a one-compartment shaft consists of two side plates, *a*, two end plates, *b*, and four posts, *c*, which technically make a single set, successive sets being used to the bottom of the shaft to support the sides, and a lining of plank or lagging, *d*, is employed to prevent falls of loose material into the opening. (See Fig. 26.) For the wall plates the halved method of joint framing is employed, and at the same time a hitch or square shoulder one inch deep is cut in the tenon as a support for the post. This halving of the timbers, if used alone, greatly weakens them, and the beveled hitch is framed from their inner faces so that their full strength may be brought to the support of the shafts. (Fig. 26, *z*.) The dimensions of the set are such that the plates when fixed in position are separated 5 ft. from center to center, the practice being to increase the size of the timbers in heavy ground rather than to place the frames nearer together.

In framing the sets the utmost care is taken that the measurements shall be exact, and that the timbers shall be cut true to the line, especially for all important working shafts, large and

small. A center line is laid off upon the inside faces of the plates and the measurements for tenons, mortises and miters are taken

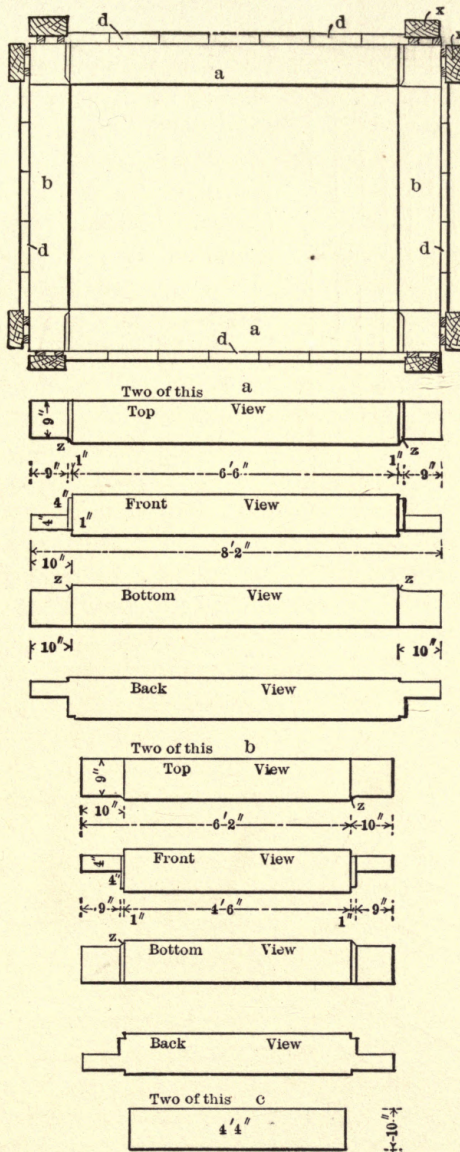

FIG. 26. — TIMBERING OF A ONE-COMPARTMENT SHAFT. Details.

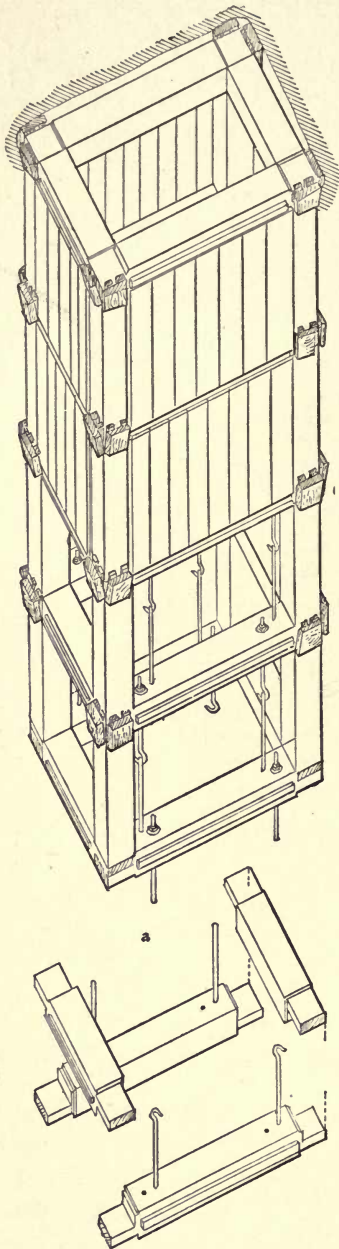

FIG 27. — TIMBERING OF A ONE-COMPARTMENT SHAFT. Perspective.

from this line. The faces of the tenons and shoulders are made at right angles to, or parallel with, and measured from the face of the plate. These precautions are necessary because of variations in the dimensions of timbers. The halved tenons of each side plate occupy the lower portion of that timber, those of the end plates the upper part, so that when in place the side plates support the end plates by their tenons. See Fig. 27, *a*, showing the isometric perspective of this shaft.

Locating Shaft Sets. — When a shaft is to be sunk from a surface too level to furnish possibilities for the disposal of the waste material coming up from below, it is necessary to elevate the top or collar of the shaft above the surface of the ground. This is accomplished by building up a cribwork of rough timbers to the desired height by placing logs of sufficient length in layers by fours or more across each other, with the shaft opening in the center. This cribbing is reinforced by waste filled in against it, and with this as a backing the shaft sets are located in position and blocked securely against the cribbing.

It also happens at times that the top material in which a shaft is to be sunk is too loose to support the sets by simple blocking. In this case the tenons at both ends of the side plates are made to extend beyond

the limits of the shaft, and these extensions are bolted to cross timbers above or rest upon such timbers as a support, the latter being of a length sufficient to bear upon the ground to either side of the shaft, and thus support its weight until it shall have entered rock firm enough to afford secure support to the sets by blocking and wedging in the usual manner. (See Fig. 28, *a* and *b*.)

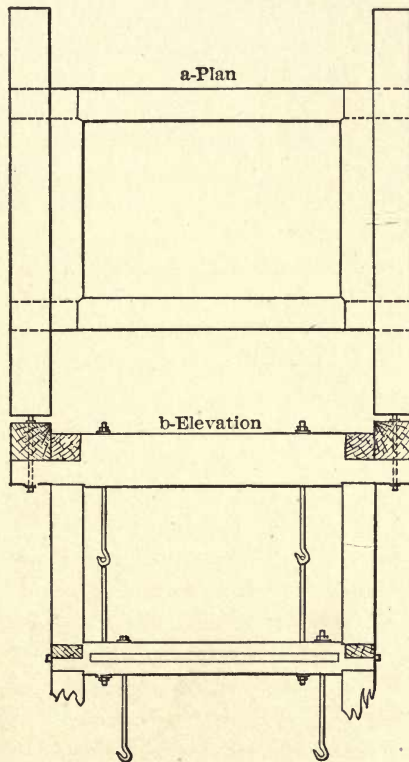

FIG. 28. — METHOD OF SUPPORTING SHAFT SETS.

The process by which shaft sets are located and fixed in position as integral parts of the shaft is as follows: The side plates of the set to be put in place are swung to the set above by hanging hooks or bolts, which are made usually of 0.875-in. round iron, hooked at one end and threaded at the other as far as may be necessary. (See Fig. 20.) These hooks are used in pairs, the length of each being about 4 in. greater than one-half the height

of each set from outside to outside of the wall plates, measured vertically. Thus, with plates of 12-in. cross-section in a 5-ft. set, the length of each hook would be about 3 ft. 4 in., with the bolt end threaded for 6 to 8 in. These bolts are the simplest and most easily manipulated device yet constructed for hanging a set in place. Holes are bored through each side plate, two at fixed points near either end, to receive the bolts, one hole at each end being used to hang the plates to the set above while the other holes are intended for the next succeeding set. Cast-iron washers are used between the plate and nut to give bearing to the latter when binding the sets together. The bolts having been located in the plates, the hooks attached to the loose timbers are caught upon the hooks of the set above, the end plates are put into place, their tenons resting upon the tenons of the side plates, the posts are set in the hitches cut to receive them, and the nuts are screwed down until the frame is tightly bound to the set above. If this upper set is properly level, and the framing of all the parts correctly done, the center line marked upon the new set must be level. Blocks *x* are placed on the two sides of each corner in line with each plate, between wall-rock and frame, and wedges are driven to tighten the set in its proper position. (See Figs. 26 and 27.) The back of each plate carries a strip nailed thereto, and resting upon this as a ledge for support is placed the plank lagging or lining of the set. Filling is stowed behind the lagging, as the planks are put in position, sufficient to prevent movement of the surrounding ground that would be likely to throw the shaft out of plumb. The same process is repeated as the sinking progresses to the bottom or sump of the shaft. In dangerous ground the practice is not to remove the bolts after the sets have been located, and it is well in any case to leave them in place for several sets from the bottom of the shaft, in order to bind the frames firmly together at this point.

Alinement of Vertical Shafts. — Various methods of alining the timbers of vertical shafts are in use, the most satisfactory probably being the combination straight-edge and plumb-bob. A double straight-edge of a length sufficient to extend over three wall plates in position — about 11 ft. for 5-ft. sets — is made, near the center of which is attached a plumb-line of a length of about 4 ft. A hole is cut in the straight-edge near its bottom end, in which the bob may swing freely, while a cleat attached

just above this point serves to confine the line so that it is quickly located at the center mark, and a line is drawn upon the flat side of the piece parallel to the true edge, with which mark the plumb-line must coincide when the true edge is exactly vertical. (See Fig. 16.)

The set, having been bound to the one above, and blocked to its approximate position, is then alined truly with the two sets above by means of the straight-edge (Fig. 15) and by the combined straight-edge and plumb-line (Fig. 16), and is brought to its exact position vertically, the wedges being driven first at one side and then the other until the set is in place. Usually the sets are alined first at the side, the side plates first at one end and then at the other being brought into position by the wedges, when the process is repeated with the end plates in order to aline the ends of the shaft. Should it be a shaft of two or more compartments the side plates are alined by blocks and wedges in line with the divisional girts separating the compartments after the corners of the shaft have been brought to their places in the same manner as has been described. If the timbers are rightly framed the inner faces of the wall plates should exactly coincide vertically with the inner faces of the sets above. The frame having thus been brought into and fixed in its true position, the lining is placed and the set is complete. (See Fig. 27.)

Repairing Shafts. — When, by reason of undue strain, weakness develops in one or more of the timbers of a shaft, the faulty pieces must be removed and replaced by new ones. Preliminary to this work several sets, particularly those next above the point at fault, are tightly bound together by the hanging bolts. If posts only are to be replaced it may be accomplished by removing the lagging adjacent, excavating enough ground from behind each post to allow of its being driven back from the shaft until it is clear of the timbers, or it may be chopped out with little trouble. The new post is then placed in position from behind, being driven or wedged into place and fitting into the hitch framed to receive each post in the plates. When necessary to replace the wall plates the lagging of the adjoining sets above and below is removed, the blocks are knocked away and the posts taken out, when the plates may be released and new ones put in place. The posts are then returned to their position, the set is bound to the plates above and below by bolts, blocked, wedged, and

alined, lining is put in, and the repairs are complete. It may happen that the ground will not stand during this process, in which case false timbers and lining must be used to hold the walls of the shaft in place.

Timbering Shafts in Loose Ground. — Shafts are frequently sunk in ground that breaks away from the walls before a set can be placed in position, and a quick process of lining the sides of the excavation is necessary. A method of false lining, largely in use throughout the West, keeps the loose earth from falling. It consists of planks of desired lengths placed vertically, and so blocked and wedged into position as to press each piece outwardly against the walls. The top end of the plank is blocked from the wall against the lagging of the last set placed in position, reaching a foot or so above the wall plates of that set. The plank is further blocked and wedged away from the wall-plates themselves, the effect of this being to throw the foot of the piece backward from the shaft against the side of the excavation, and thus prevent the material from coming in. This lining is often carried completely around the shaft. (See Fig. 29.)

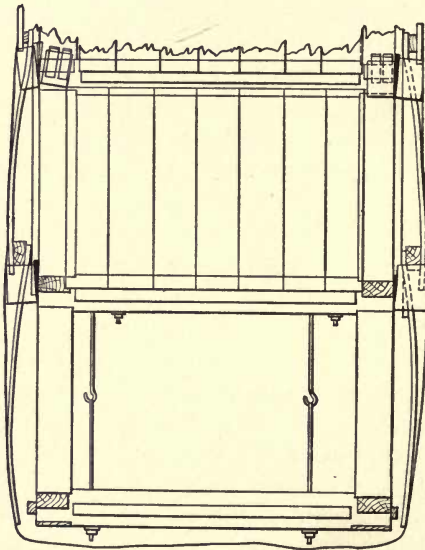

FIG. 29. — LINING FOR SHAFTS IN LOOSE GROUND.

Timbering Shafts in Running Ground. — In soft running ground, or loose ground too heavy to allow of placing the false

lining above described, a method of spiling is employed that is practically identical with that used for driving levels through similar material. The process consists of supporting the dangerous ground beneath the last set placed in position, by what might be termed an enclosing and protecting shield of plank spiling or forepoling, that is, advanced downward from that set piece by piece as the material is excavated from within. The spiling, *a*, sharpened at the foot, and often shod with iron at the head, is driven with a sledge, one plank at a time being advanced for a short distance as the material is withdrawn from before it. The spiling is held in position by the set and the material through which it is being forced, only enough of this being removed at a time to allow it to be driven a short distance; otherwise the pressure from without may force the lining into the shaft. Each plank around the shaft is driven successively one by one, until the entire shield has been advanced, when the process is repeated and continued until the shaft has been excavated to a depth sufficient to allow of the placing of another set in position, the idea being to advance the shield by successive small stages during the work.

The spiling is started at a considerable angle, but as it is driven downward it tends to approach nearer and nearer the vertical until, when the new set has been permanently located, tail pieces or bridges *b* are placed to hold the bottom of the planks in position, and at the same time to furnish an opening between the plates and the foot of the shield through which to drive the spiling for the next succeeding set. These tail pieces may be permanently left in place, or removed in order to allow the planks to settle against the top of the spiling below, binding the latter in place and making a closer lining. Ledge strips *c* may be attached to the plates, and the usual close lining placed about the shaft as additional security, and to keep from the shaft material that otherwise might work in at the corners. The posts prevent spiling from being placed vertically so as to form a continuous close lining, which difficulty may in a measure be overcome by diagonal spiling so placed as to cover these openings, whether they occur at the sides or at the corners of the compartment shafts. Where possible the sets should be blocked and wedged to place in order that the shaft may be kept plumb, and the hanging hooks should always be retained in treacherous

ground. The above process is repeated successively until the shaft has entered firm ground, when the usual methods of timbering may be resorted to. (See Fig. 30.)

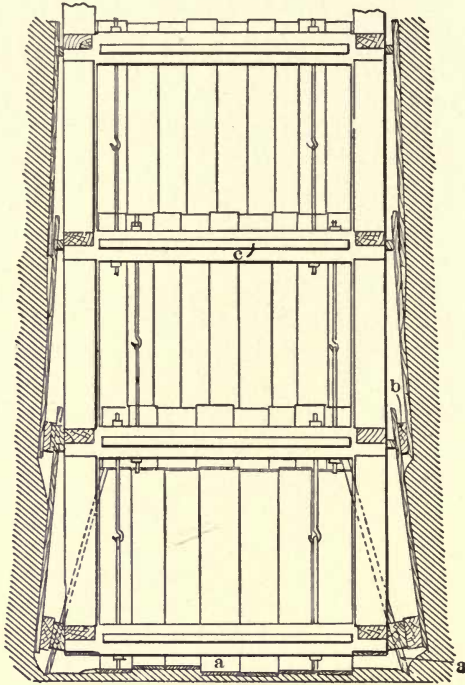

FIG. 30. — SPILING IN RUNNING GROUND.

Two-Compartment Shafts. — In preliminary operations, in a mine where pumping is necessary, two-compartment shafts are employed, one of the divisions being given up to hoisting and the other to pumping and ladders. Both compartments are made of the same size, the usual practice in the West being for each division to be 4 ft. along the length of the shaft by 4 ft. 6 in. across its width, hoisting cages being most frequently constructed for operating in compartments of those dimensions. The timbering of a shaft of this size is framed in a manner almost identical with that of the one-compartment shaft, with the exception that the side plates are made longer, and that a divisional piece, called a center girt, is made to fit by tenon and mortise across the center of the side plates. Center posts are also used to

strengthen and stiffen the frame. The methods of locating and alining the sets are those used for the one-compartment shaft.

Three-Compartment Shafts. — Should the mine warrant more

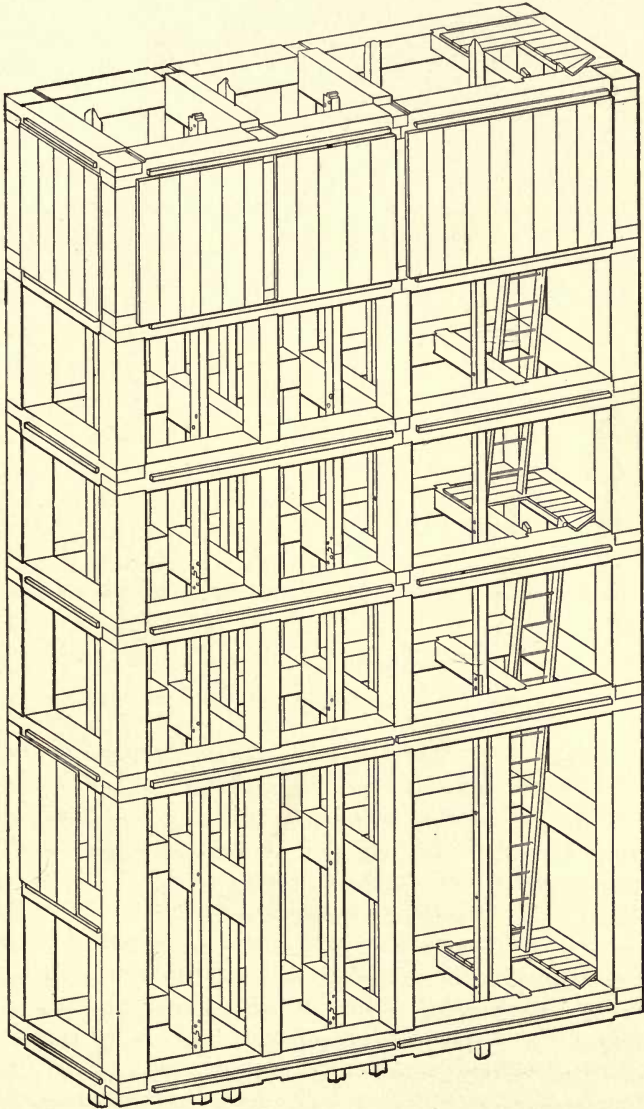

FIG. 31. — FRAMING OF THREE-COMPARTMENT SHAFT. Perspective.

extensive hoisting appliances, a third and larger compartment for pumping is added to the two-compartment shaft, while the smaller compartments are given up to hoisting. Because of the jar and strain upon the timbers from winding, this work should be done in the compartments that are supported by the solid side plate, as they are more rigid and self-sustained.

Although three-compartment shafts are often enlargements from two-compartment shafts, nevertheless most of the large working shafts throughout the West are those of three compartments that have been commenced and carried to the bottom as such. Fig. 31 gives the isometric perspective of a shaft of this type. This framing is such as obtains the greatest possible stiffness and strength for the wall plates, and represents the most advanced timbering in use. The arrangement is excellent. The small cage for the use of the pumpmen, traveling closely against one of the side plates to allow space at the opposite side of the compartment for locating the water-column, air- and steam-pipes, is hoisted by an independent engine, and the safety arrangement for the ladders is carefully designed.

The sets are located in the same manner as are those of the single-compartment shaft. The side plates are hung to the plates above, the end plates are placed in position, the solid center girt is fitted into the mortise cut to receive it in the center of the solid side plate, the divisional girt is located at the joint between the long and short side plates, the eight posts are placed, and the set is tightly bound by the hanging bolts to the set above, blocked, wedged and alined. The side plates are sometimes made of a single piece, framed to receive two solid center girts, which make the shaft more rigid. Long timbers of this kind are difficult to handle in a shaft, and it is not always possible to use them. Where possible they should be placed at the stations, both above and below, in order to make the frame of the station set as strong as possible, as shown in Fig. 31.

The principal reason for the almost invariable adoption of the double-hoisting-compartment shaft in large operations throughout the West is that of balancing the loads in winding. One of the cables winds over, the other under, the same engine-shaft, and when the two drums or reels are both clutched to the shaft the weight of one cage and load acts in a measure to balance the other, thus saving power.

Four-Compartment Shafts. — Four-compartment shafts, with three hoisting divisions, may be divided into three classes, viz.: the single-width shaft, largely used throughout the Witwatersrand goldfields of South Africa; the “L” shaft, now practically abandoned for good reasons; and the double-width shaft, which it would seem is likely to come into general use as being one peculiarly adapted to the vast operations of extensive mining.

In the single-width four-compartment shaft the two end hoisting compartments are employed for raising ore, and, on occasion, for lowering timbers; the third is used in sinking and by the pumpmen, and likewise for lowering timbers into the mine, while the fourth compartment is given up to the pumps, the water-columns, air- and other pipes, and to the ladders. The framing of the timbers for this shaft is almost identical with that for the three-compartment shaft, except that the divisions are such that each section of the side plates supports two compartments. (See Fig. 32.)

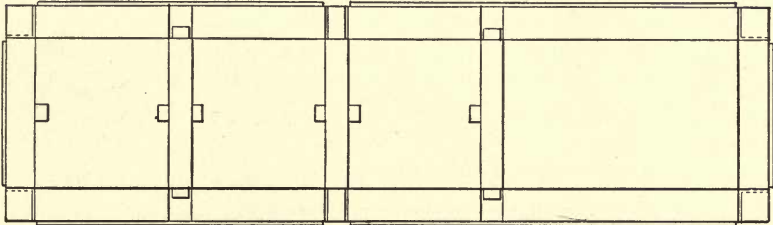

FIG. 32. — FRAMING OF SINGLE-WIDTH, FOUR-COMPARTMENT SHAFT.

The double-width four-compartment shaft practically comprises two two-compartment shafts placed side by side, the end plates being lengthened in order to form a double-width shaft. Two of the end compartments are used for the hoisting of ore and the lowering of men and timbers, one of the two remaining is employed as a cageway for pumpmen and timbermen, with its station cut on the opposite side of the shaft from that for the hoisting divisions, while the other is given up to the uses of the pump and for carrying the water-columns, air- and other pipes, and ladders. See Fig. 33, giving the plan of the shaft, and *a*, *b*, *c* and *d* the method of framing the timbers, which is similar to that for the three-compartment shaft, and Fig. 34, showing the isometric perspective of the construction.

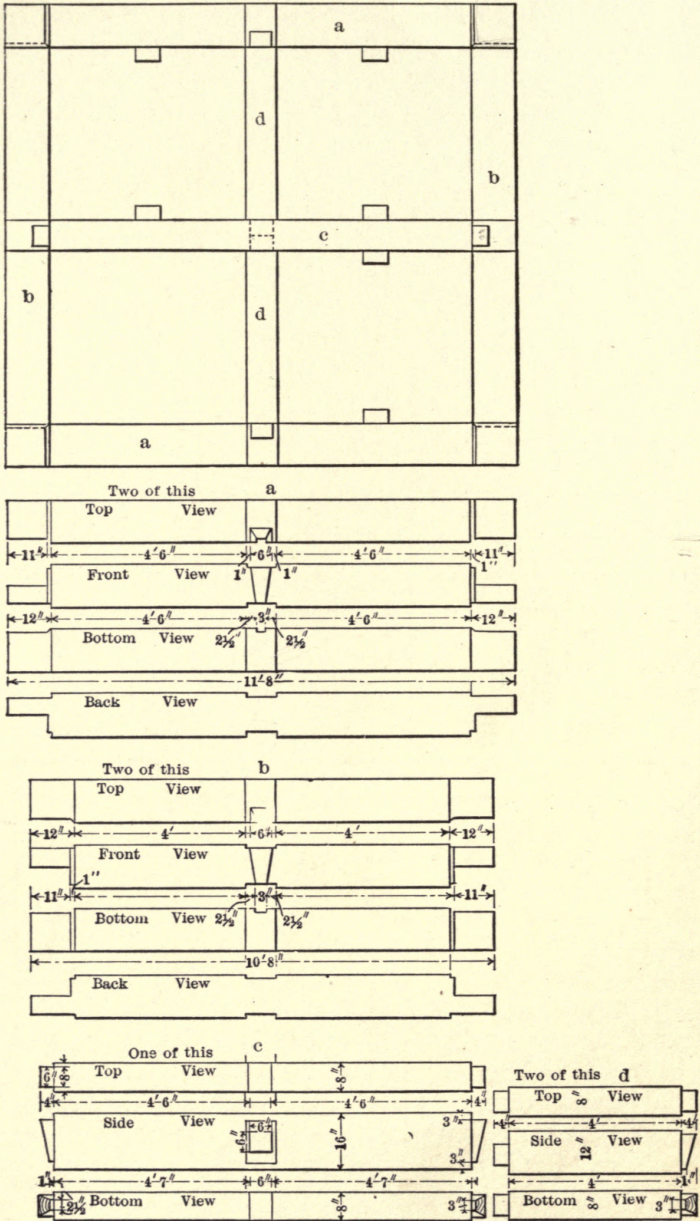

FIG. 33. — FRAMING OF DOUBLE-WIDTH FOUR-COMPARTMENT SHAFT. Plan and details.

The wall plates of this shaft are solid throughout their length, giving great strength and rigidity to the frame; none of the tim-

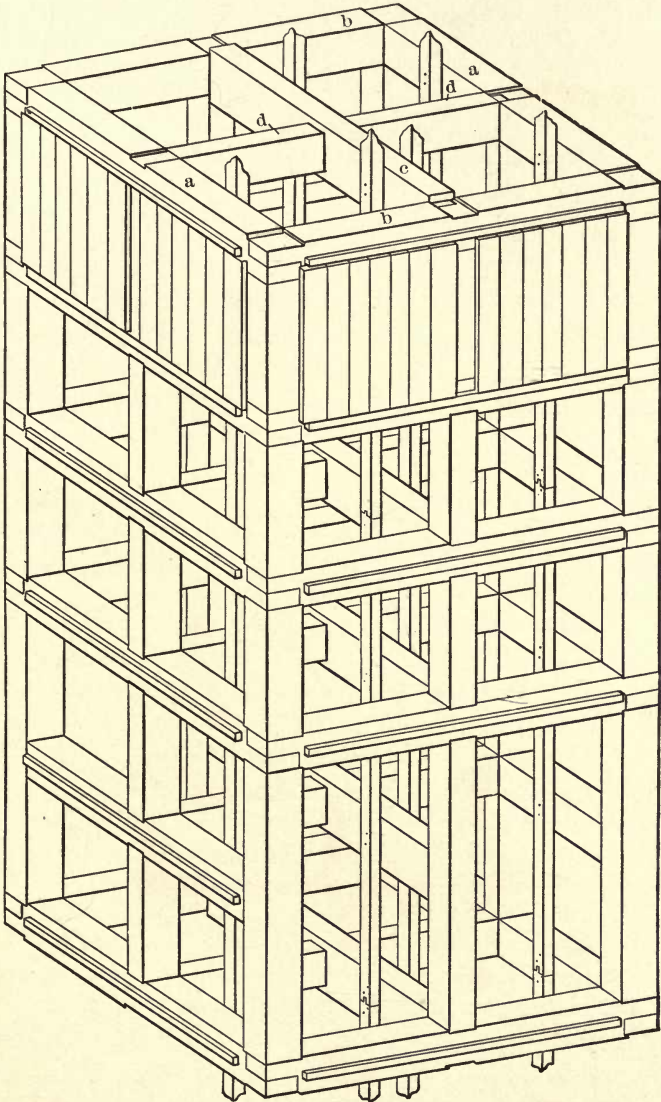

FIG. 34. — FRAMING OF DOUBLE-WIDTH FOUR-COMPARTMENT SHAFT.
Perspective.

bers are so long as to render their handling in the shaft difficult, while at the same time the excavation is nearly square in cross-section, and of a size to facilitate the breaking of ground, and the placing of the frames in position. Furthermore, the bracing received by the plates from the interior cross girts, both long and short, greatly solidifies and strengthens the set. The great capacity of this shaft, together with its compactness, strength, and rigidity, and its accessibility for repair, renders it especially adapted to extensive mining operations. As compared with the three-compartment shaft this shaft requires the excavation of but 450 cu. ft. more of material in each 100 ft. of its depth than does the former.

Ladders. — The ladders that are placed in the man-ways of a shaft, and in other inclined and vertical passageways throughout a mine, are usually made in 5-, 10- and 15-ft. lengths or thereabouts. (See Figs. 17, 18 and 19.) They consist of two supporting 2x4-in. scantlings, placed parallel about 14 in. apart, to which are fixed cross pieces or rungs at regular spaces of about 10 in. The rungs may be of wood or iron, preferably the latter, unless the mine waters are sufficiently acid to attack the iron — which is often the case in the deep workings. The wooden rungs are often simply spiked to the scantlings, or they may be set into hitches cut in the edges of the side pieces, and nailed firmly in place. Frequently the scantlings are bored, and turned rungs are fitted into the holes, the ends of the rungs being wedged to hold them in place. While this method makes an excellent ladder, the holes weaken the scantlings materially, and, furthermore, it is almost impossible to replace a rung without destroying the ladder. The most substantial ladder, and one easily repaired, is the following: The inner face of each scantling is bored at the required intervals to a depth of 1 in. in order to receive the ends of 16-in. lengths of 0.75- or 0.875-in. common iron pipe, cut exactly. At every fifth rung smaller holes, concentric with the others, are bored entirely through the scantlings, through which and through the lengths of pipe located at such points are passed 20-in. lengths of 0.75- or 0.875-in. round iron, threaded at the ends to receive nuts. When the different rungs of the ladder have been located in their places these nuts are tightened upon washers fixed between them and the scantlings, binding the ladder frame securely together. These rungs possess great strength,

while but little strength is lost to the scantlings, and the ladder is easily repaired.

Shaft Station Sets. — At various depths, usually at intervals of 100 ft., levels are run from the shaft, to and through the inner workings of the mine, and at such points stations or large rooms are excavated in the walls of the shaft, and timbered to serve as centers for the storage of material of all kinds, whether coming from or to be distributed to the various working places. The construction of these stations necessitates a change from the usual shaft framing at such points, in order to obtain the needed hight for an entrance from the shaft to the station. Should the shaft have been carried below the point for a station, the obstructing wall plates at the entrance must be removed, together with their girts, and the posts both above and below. The longer posts, fitting into the gains framed in the plates, are then located, and distance pieces for the walls and girts for the center of the shaft — the same being tenoned to mortises in the posts — are placed in position, occupying that of the wall plates removed, except that the station entrance is left free of such pieces. The remaining sides of the shaft are then lined with the usual tight lagging. See the isometric perspectives of the three- and four-compartment shafts. (Figs. 31 and 34.) False pieces or temporary struts holding in place timbers to support the walls of the shaft during this operation are used when necessary.

STATIONS. — The ordinary working station is made of a width, in the clear of its framing, of the two hoisting compartments, or of a width which is enlarged at the pumping stations by an additional chamber usually equal in width to the length of the pump compartment, for the accommodation of the pump; the usual practice being to make the inner faces of the station sets aline with those of the shaft timbers.

In hight the stations are made equal to that of the shaft entrance, less the thickness of the flooring, but the roof is made to slant downward from the second or third station set to the end of the room. The length of the station varies with the conditions, from 20 to 40 ft. being usual.

The timbering of stations consists of the four-piece level sets, enlarged and placed at such distances apart as the nature of the ground requires, usually from 5 to 10 ft. Distance pieces or girts are used to hold the sets in position, this in connection with the

usual blocks and wedging. Ordinary plank lagging prevents the fall of loose rock, and a flooring of 2- or 3-in. planking is laid, to which is screwed a turning sheet of boiler plate, whereon ore cars may be turned or slewed around. A sump tank to hold the mine water that is to be pumped to the surface is framed and placed beneath the pump division of the station.

In loose ground it is necessary to timber the station by a system of loose piling, analogous to the method explained in driving levels through similar material.

LEVELS. — Levels include all those approximately horizontal workings through which mine transportation to and from the working places is carried on, and include adits, cross-cuts, and

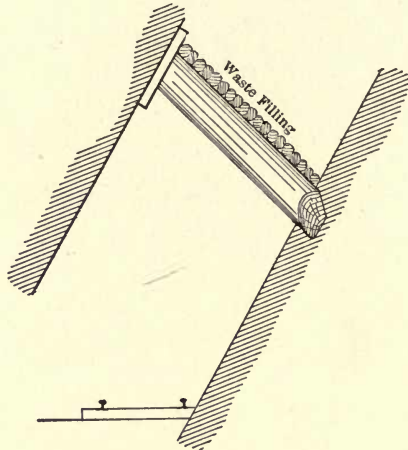

FIG. 35. — SINGLE-PIECE SET.

drifts. An adit, usually miscalled tunnel throughout the West, is a horizontal tramway driven either within or from without the ore deposit, and connecting the interior workings of the mine with the surface, while an adit-level in contradistinction includes only those portions which are contiguous to and immediately connected with the adit, and are operated through it. A drift is a horizontal opening driven longitudinally with and in the ore-body, its function being to afford a means of communication along the lode. A cross-cut is that part of a level which is driven laterally across the country formation, or across the ore deposit to connect one part of the mine with another. The methods of timbering these various openings are identical, and will be treated under one head.

The timbering of levels is accomplished by what is known as the single-piece, or the two-, three-, or four-piece set, depending upon whether one, two, three, or four timbers are employed. They are also known as the quarter, half, three-quarter and full set. The pieces are known as the post, if approximately vertical, the stull if inclined, the cap or top piece, and the sill or bottom piece. Upon the latter rest the posts of the four-piece set, the sill being used to keep the feet of the posts of a set from being forced inward by exterior pressure, and also where the ground beneath will not support the weight resting upon the set.

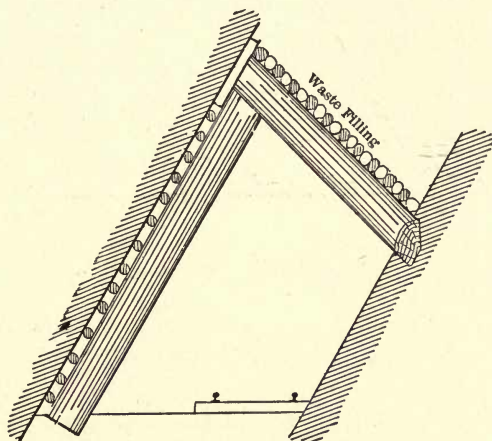

FIG. 36. — TWO-PIECE SET.

Where the sides of a drift are sufficiently strong, when the deposit is of a width of not more than from 15 to 20 ft., a single piece is frequently used. (See Fig. 35.) Should either of the walls prove to be weak, this single piece is supported at either end as shown in Fig. 36, forming what is called the two-piece set. If both walls are too weak to support the single piece, or should the deposit be of considerable width, posts are placed under both ends, somewhat as shown in Fig. 37, forming the three-piece set. This set is, however, usually made from framed timbers, either round or squared; the posts of the set being of equal length, and the sets nearly or quite of equal size. These sets are held in position by distance pieces, either of poles sledged into position between the sets, or of squared timber, in which case the sets are framed with a hitch to receive and support the ends of the piece. Poles

used for this purpose are called "sprags," while the square pieces are known as "girts." The framing of squared or round timbers for this set is practically identical, but round timbers because of

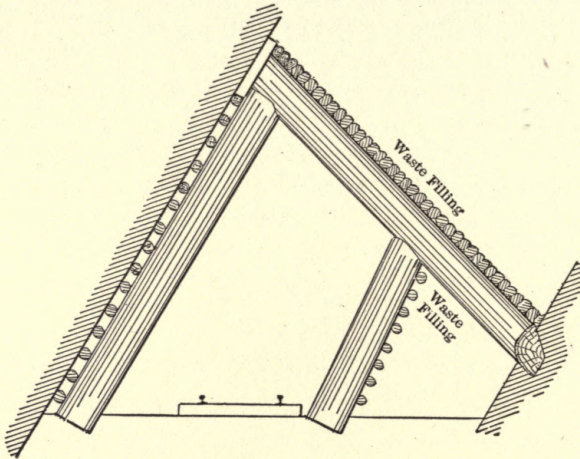

FIG. 37. — THREE-PIECE SET.

their unevenness usually require that a pattern shall be made as an aid to systematic framing. The three-piece set is usually made of round timbers, with the posts set with a spread or slant outward at the bottom as an aid to resist the outside pressure.

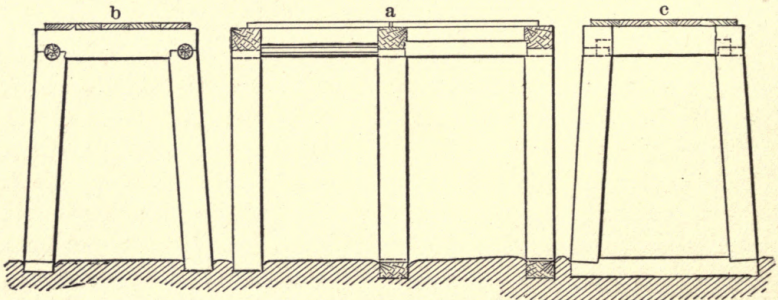

FIG. 38. — THREE-PIECE SET.

The feet of the posts are set into hitches or rests at the floor of the level; this also tends to strengthen the set against the intrust. (Fig. 38, *a* and *b*.)

The four-piece set is usually framed from squared timbers,

the posts being set upright, making the square set, or with a slant outward as in the three-piece set. The set consists of the cap, sill, and two posts, usually carefully framed. In adits the set is often alined with considerable exactness, and when thus placed the passage presents a pleasing appearance. In adits and cross-cuts the posts are usually given a slant. Often, however, this set becomes an integral part of the regular square-set system as applied to the extraction of masses on the levels and in the stopes of the large metal mines. (See Fig. 38, *a*, *b* and *c*.) The framing of this set often becomes massive, especially in the heavier ground of adits. A center post is often placed in position for forming the double tramways. (Fig. 39.)

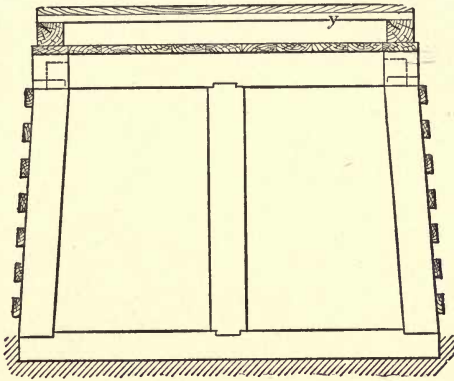

FIG. 39. — FOUR-PIECE SET.

The ground between the sets is held in place by lagging of poles or sawed plank, which rests at either end upon the timbers. Being of comparatively small strength a lining of this character will yield to unusual pressure, and thus give evidence of incipient crushing that would soon destroy the timbers if not attended to.

Timbering Levels in Loose Ground. — For this purpose the process known as spiling or forepoling is employed, its use being somewhat similar to that described under one-compartment shafts. The spiling may be of sawed plank or of poles of the required length, sharpened at the forward ends, and with their heads protected by an iron shoe when necessary. A set having been fixed in position (see Fig. 40) a bridge *y* is placed upon the cap supported by the blocks *x* at either end. Between this bridge and the cap the spiling *z* is started, sloping upward at an angle.

As it is driven forward, piece by piece, the material is picked away from the point of each plank as it is forced ahead a short distance at a time. In this manner the entire shield is advanced through successive small stages until it has been driven forward through about half the distance to its final position, when a temporary false set, *a*, is located to support the spiling. The driving is then continued until the shield has been advanced to its place. The regular set is then fixed in position, a bridge is placed upon its cap, and the false set removed, which allows the spiling to settle upon the bridge. The same process is continued in excavating for the succeeding sets while passing through similar material until more solid ground is reached. When necessary the same

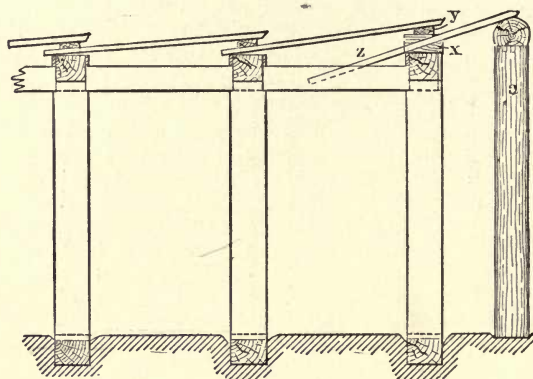

FIG. 40. — SPILING IN LOOSE GROUND.

process is also applied to the sides of the opening, bridging the posts in the same manner as the cap is bridged and similarly advancing the shield. In very soft ground it is sometimes necessary to employ the same method in carrying the bottom of the level forward. In very soft or running ground the edges of the plank spiling must fit closely against each other, and at the same time the face of the working is retained by breast boards held in position by struts footing against the forward set. These boards are advanced behind the forward edge of the shield, being removed one at a time, and placed farther ahead as the material is removed from in front of it, a longer strut being used to support it in its new position.

TIMBERING OF THE WORKING PLACES IN A MINE.

As regards the process of extracting the valuable materials from their places of deposit there are in use many methods well adapted to keeping the workings open under the varying conditions. Of these the most simple are those employed in the horizontal or bedded deposits, where often the overlying rocks are of such strength as to require little support other than that furnished by the occasional pillar of ground left in place for this purpose. Even the material left in these pillars is sometimes removed, and the roof allowed to fall, when it can be done without injury to future operations.

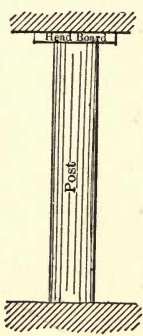

FIG. 41. —
POST AND
HEAD BOARD.

Posts. — The method of supporting the roof of horizontal deposits by posts or props is almost universally employed, and is the most simple artificial means of keeping open the working places of mines of this character. These posts are formed of sections of trees of various diameters and of lengths up to 20 ft. They are placed in a vertical position, normal to the roof and floor of the deposit, with a flat plank, called a cap piece or head board, placed upon the top of each prop to distribute the pressure evenly upon the timber, and to give greater bearing surface against the rock. (See Fig. 41.)

Cribs. — Another method employed is that of cribbing, or, as it is sometimes called, penning. This consists of building up a crib or pen from floor to roof of logs, laid in pairs or in greater numbers across each other. These cribs may be made solid if desired, but this is not often done, for practice prefers to make a single or double pen and fill its interior with waste material, which is usually at hand in underground workings, and the use of which greatly strengthens the crib. (See Figs. 42

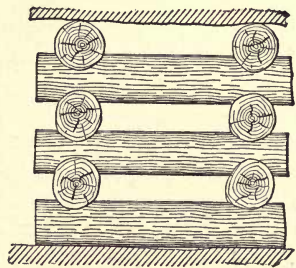

FIG. 42 — CRIB.

and 43.) The stowing of waste in underground excavations from which the valuable materials have been extracted is often resorted to and forms a solid filling that will, with comparatively

little subsidence, support any pressure. Waste filling is frequently used in connection with and as adjunct to the various systems of timbering employed in supporting the walls of ore and other deposits. It forms the only permanent and certain means of retaining the walls of orebodies in approximately their original position.

The metal mines of the West for the most part consist of deposits that dip below the horizontal at varying degrees up to the vertical, the dip of the blanket veins and other bedded deposits depending upon the uplift of the enclosing formations, while that of the fissure veins follows the course of the fissures cutting through the earth's crust. Contact veins may present the characteristics of either of the above mentioned classes, and the chambers or isolated pockets of valuable materials may follow certain lines of deposit, or be without regularity or regular form.

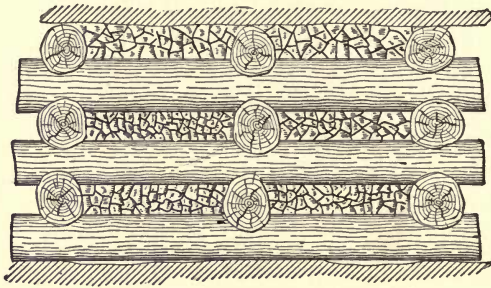

FIG. 43. — CRIB WITH WASTE FILLING.

In size these different deposits vary from the deposits too small to be successfully worked in a commercial way, to immense masses of ore, the extraction of which brings into use all the science of the miner and of mining. Some of the methods in use for timbering these excavations, during and after the extraction of the ores, are but the application of old methods to present use, while other systems are distinctly modern, both in origin and application.

Stulls. — Of the older methods there is principally and primarily the stull system, which is but the application of the post of the flat deposits to the use of the inclined veins. Stulls are almost universally employed in mining the smaller veins, with or without waste filling as an adjunct. They consist of sections of trees, pine, fir, oak, or other substantial woods, round, and peeled

of their bark. These sections are of all lengths up to about 20 ft., as may be required at the points to be timbered, and in diameter up to about 4 ft. The greater the diameter the greater the strength of the timber. Length beyond certain limits decreases the power to resist pressure, as the piece is more liable to bend or buckle under the weight.

Like the post the stull is placed with a head board to distribute the pressure, and to give greater bearing surface to the stull in supporting the hanging wall of the deposit, while the foot of the stull is trimmed and squared to fit more closely into the "hitch" cut into the foot-wall to prevent the timber from slipping from its place. (See Fig. 44.)

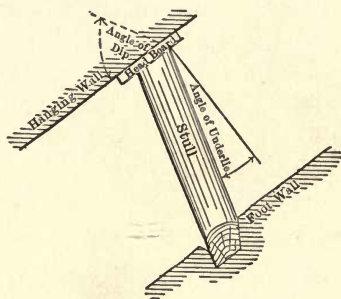

FIG. 44. — STULL.

Unlike the post the stull is not located in position in a line normal to the walls of the deposit, but at an inclination thereto approximating at a certain ratio to the dip of the vein, the angle of underlie of the stull (see Figs. 44 and 50) being about one-fourth of the angle of dip of the deposit, thus:

Dip of Vein	Angle of Underlie of Stull	Dip of Vein	Angle of Underlie of Stull
10°	2½°	40°	10°
20	5	50	12½
30	7½	60	15

The reason for this underlie of the stull is that if the piece were placed at right angles to the walls of the vein a slight movement of the hanging wall would cause the stull to fall. Also the stull usually carries the weight of waste filling above the levels, and this it would be unable to do if placed perpendicular to the wall, while this weight tends to wedge the piece more tightly into place if placed at an angle above the perpendicular to the walls.

Where the foot-wall of the vein is too weak to support the stull in position a false stull is often placed to transpose the ver-

tical weight upon the foot of the stull to a diagonal thrust against the hanging wall. (See Fig. 45.)

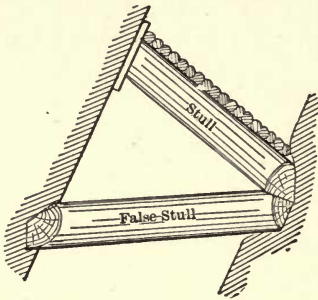

FIG. 45. — STULL AND FALSE STULL.

In wide veins stulls are often reinforced, so as to enable them to bear both the vertical weight of the waste filling above and the side pressure of the walls, by what is known as the double-stull method. This consists of false stulls placed beneath the stull proper, the former being placed with a foot-hitch, and the stull, supported in its position by logs resting upon two or more of the false stulls beneath to either side, footing against the foot-wall without a hitch to receive it. This method is shown in Fig. 46, *a* being the end view and *b* the plan.

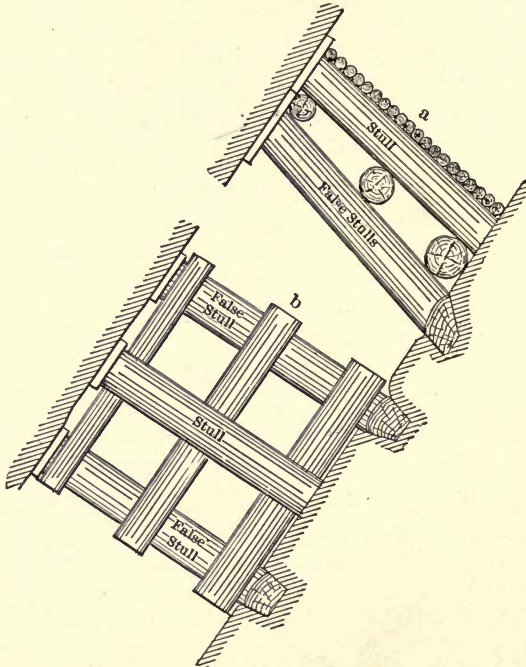

FIG. 46. — DOUBLE-STULL METHOD.

In vertical or nearly vertical veins it is impossible to place the stull in position with the usual underlie, and some method

is necessary that will change the vertical weight due to waste above into a diagonal thrust against the walls. This is done as is shown in Fig. 47, *a* by means of the saddle-back system of bracing,

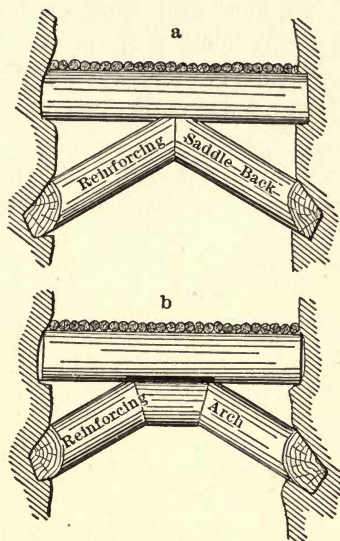

FIG. 47. — SADDLE BACK AND ARCH.

and *b* by the arch with key-piece. This saddle back is sometimes used, as in Fig. 48, to carry the weight of waste filling above, but it is without value to resist side pressure.

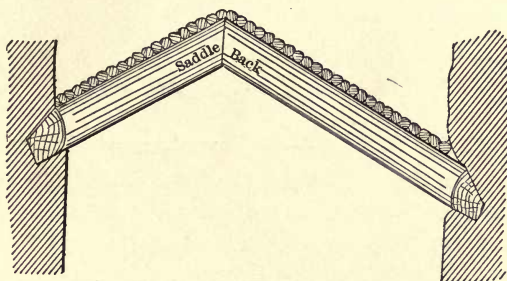

FIG. 48. — SADDLE BACK.

Penning. — A method of timbering known as penning is sometimes employed in the inclined veins, and is nothing more than the crib of the flat deposits applied to the incline. It consists of cribs of logs built up from the foot-wall of the vein to the hanging wall, which it supports. Occasional longer timbers are

used to tie the cribs together, and for the purpose of forming sills and caps for the passageways of the mine, as shown in Fig. 49. This method of using timbers for keeping open the working places of a mine is expensive, and requires quantities of timbering, but in connection with waste filling it is about as permanent as any method of timbering can be. It also has the advantage of a certain flexibility without weakening during movement.

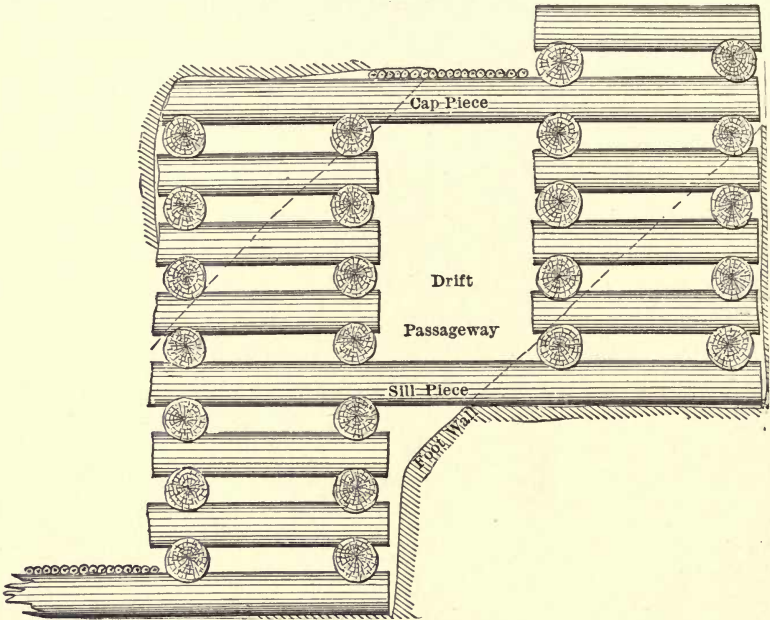

FIG. 49. — PENNING.

Square Sets in Stopping. — This system of timbering is peculiarly adapted to the extraction of ores occurring in large masses. In fact, the size of the deposit matters little if waste filling be used in connection with the sets. The method requires vast quantities of timber, and the framing of the pieces is no small item of expense, but the handiness of the system is so great, and its adaptability to all the needs of mining operations in extracting the valuable materials from their places of deposit is such that it has replaced many of the cheaper systems of timbering. Indeed, it is a fact that its use in large operations is often found to be cheaper in the end than are many of the supposedly more eco-

nomical methods, and this in spite of the fact that the framing of the sets involves no small item of outlay. Briefly, the system consists in filling up the excavations resulting from the extraction of ores with what might be termed open blocks or cells of timber that may be added to and extended indefinitely in every direction, lengthwise of the deposit, across it, and between the levels, while the slope of the body matters little for the reason that, in following the ores between their walls, sets may be extended laterally

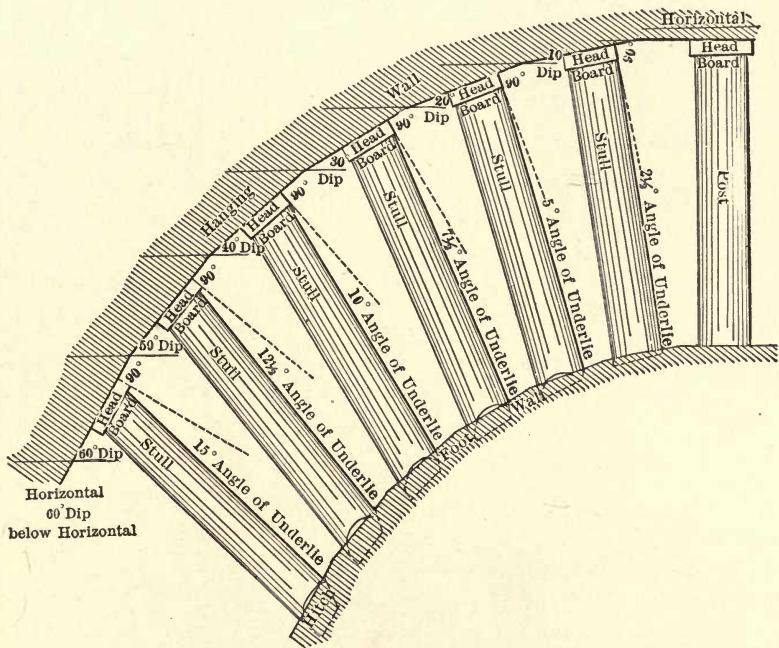

FIG. 50. — ANGLE OF UNDERLIE OF STULLS.

outward from the main body of the timbering at any point of the foot-wall, or left out when the slope of the hanging rock encroaches upon the timbering.

The set is made up of posts, cap, and girt, the former being as usual placed in an upright position, in line with the posts above and below. The cap rests upon the top of the post, and is invariably placed across the deposit, the cap of one set becoming in effect the sill of the set next above; while the girt, which likewise is set upon the post, is located along or longitudinally with

the run of the orebody. The sets are, in the best practice, framed for a height of 7 ft. in the clear of the timbers; the reason for this being that this length obtains the full strength of the frame at the same time that it saves timber in the mine, and leaves sufficient height for passage without inconvenience. This height also allows of placing the reinforcing sets in position, and still permits passageway if necessary. Across the deposit the caps are made

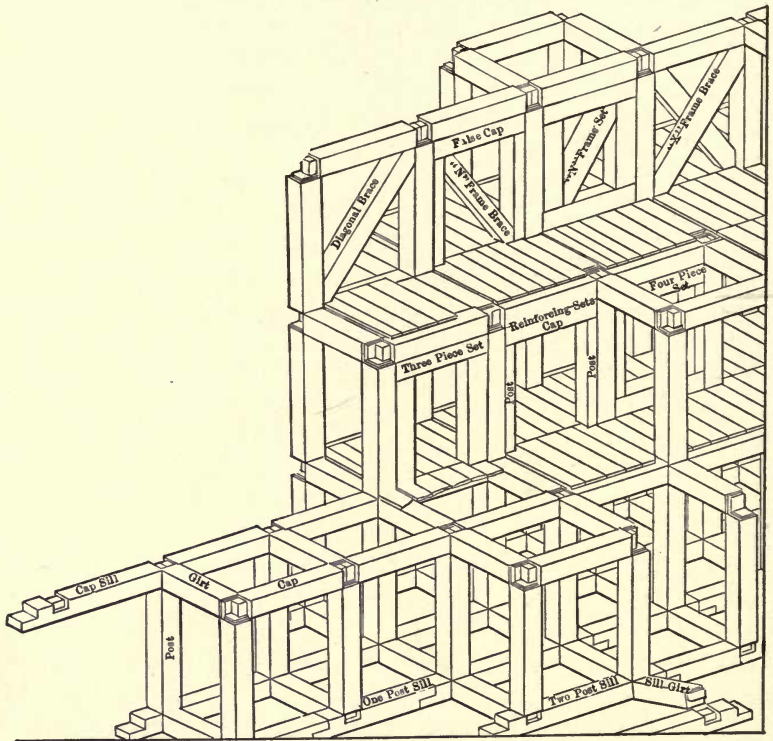

FIG. 51. — SQUARE SETS IN STOPING.

of a length such as will set the posts 5 ft. apart in the clear of timbers, which gives room for working the air drills in the breasts of ore, and for other work at end points. Along the length of the orebody the girts are made to separate the cross frames by a distance of 4 ft. 6 in., adding somewhat to the number of such frames and thus giving greater resisting power to the sets against thrust from the side, from which direction the maximum pres-

sure usually acts against the timbers. (See Fig. 51.) In this figure the method of locating the sets is shown in isometric projection, and also that of placing the different timbers of the system.

Usually a heading or drift is first run along the level, as near to the center of the deposit as may be, although this is not essential, and along this excavation the sets are placed from which to build up the more extended timbering. On the floor of this drift are laid the two-post sill pieces, the sill girts are placed in position as is shown in the figure, then the posts are located, and upon them is placed a cap piece across the drift, while a girt connects this cross frame with the last one placed in position. The frame is now blocked and wedged against the top or back of the drift, and the set is completed. As material is removed from either side of this drift, one-post sills are laid upon the floor of the excavation and pinned to the two-post sills already located, a sill girt is placed, the post set upon the framing fitted to receive it, and cap and girt hold its top in position. It is then blocked and wedged firmly against the ground above, and also from the side. A 2-in. plank roofing is laid from cap to cap above the set, which performs the functions of a floor for the set next above as the timbering is carried up. When the foot-wall of the deposit is reached, the sets are carried up along its slope by means of the cap-sill, a timber which combines the functions of the cap and the sill, also shown in position in the figure. Upon these cap-sills as a foundation are built up a new line of sets, and the process is carried on to any extent by repetition. Above the sill floor, as the ground is excavated, posts are set into the gains formed by the framing of post, cap, and girt beneath, and the timbers are continued upward, outward, and lengthwise as far as may be necessary. The sets from one level are carried up to those of the level above, when short sets are placed in position to carry the weight of the upper framing.

Reinforcing Sets. — When the timbering is carried into unusually heavy ground, or where it is forced to carry a great weight, it is frequently necessary to reinforce the sets across the deposits in line with the greatest pressure, and this is done by what is known as the diagonal brace, the three-piece set, the full or four-piece set, the "N" frame brace, the "N" frame set, and the "X" frame brace. These are all shown in Fig. 51.

Ore Chutes. — In delivering the ore from the stopes above a

level to that level so that it may be loaded into cars and carried to the shaft for conveyance to the surface, a storage bin and passageway combined is necessary, and this is obtained by lining one of the sets as it is carried up from the level by a close lining of 2- or 3-in. planking, preferably the latter. These bins are designated as chutes, and the framing at the bottom of them whereby the ore is delivered into the cars is called the gate of the chute. This is made by constructing an inclined flooring, with sides, that shall project beyond the side of the chute into the tramway sufficiently far to allow the rock to fall from it into the car. Cross timbers are placed across the chutes at varying heights of about 30 ft. in order to break the fall of the rock so that it shall not destroy the gate frame. In keeping the chutes near the center of the deposit they are as often as is necessary offset toward the floor wall on an incline from one line of sets to the next lateral set on the floor above.

Waste Filling. — In average ground no system of timbering will long sustain the walls of large excavations, and waste rock from the vein and walls, especially the hanging wall, is employed for filling up the spaces between the timbers in order to make a solid filling that shall hold the ground in place. Passageways are strongly reinforced, and the flooring is removed from the different floors when waste is thrown into the excavation from above.

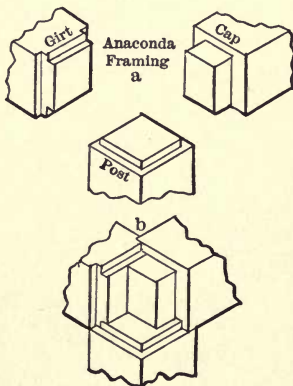
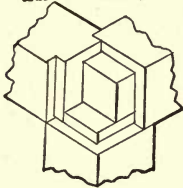

FIG. 52. — ANACONDA METHOD.

Methods of Framing. — There are several methods of framing the timbers of square sets in order that they shall come together from the six directions in a manner best suited to the needs of the occasion. Fig. 52 shows the method of cutting the timbers in use in the Anaconda mine, Butte, Mont., *a* giving the isometric perspective of the post, cap, and girt as shown separately, *b* showing their appearance when joined. The Eureka method of framing is shown in Fig. 53, and is very similar to the Anaconda frame, the latter having one more section cut from each side at each end of the girt. Both of these methods are used for opposing

pressure from the sides of the veins, the caps abutting against one another to secure the greatest strength from the timbers;

Eureka Framing



but by transposing the timbers of this set, so that the posts shall rest end on end upon one another, vertical pressure may be best resisted. This is shown in the Burlingame frame (Fig. 54), *a* separated and *b* joined, which is the Eureka framing with the post of the latter forming the girt of the former, the cap of the Eureka the post of the former, and the girt of the Eureka the cap of the former. Fig. 55

FIG. 53.—EUREKA METHOD.

presents the Richmond frame, which is a strong but complicated and expensive joint in which the cap and post are framed from 12-in. timbers and the girt of 10-in. pieces. Usually the Anaconda and Eureka frames are made of 10-in. timbers, the reinforcing sets and solid waste filling being depended upon to hold up the ground rather than by increasing the cross-section of the timber. Frequently, however, the upper levels of a mine are supported by 8-in. pieces, but this is infrequent at the deeper levels. The Eureka framing is now used in

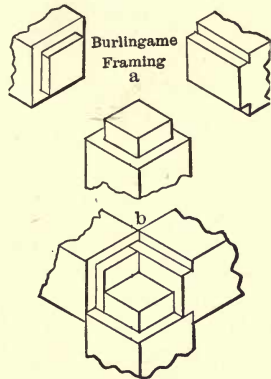

FIG. 54.—BURLINGAME METHOD.

some of the Anaconda mines as being the simplest and cheapest method of framing. Fig. 56 furnishes the details of framing timbers for the Anaconda set. The square-set system of timbering was originated to meet the needs of the situation as developed in the workings of the Ophir mine, on the Comstock lode, Nevada, by Philip Deidesheimer.

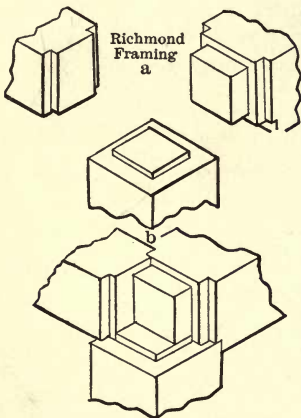

FIG. 55.—RICHMOND METHOD.

Important details connected with the methods of timbering herein described, and other systems now in successful operation among the metal mines of this country, are excluded from this necessarily abridged article.

MINE TIMBERING

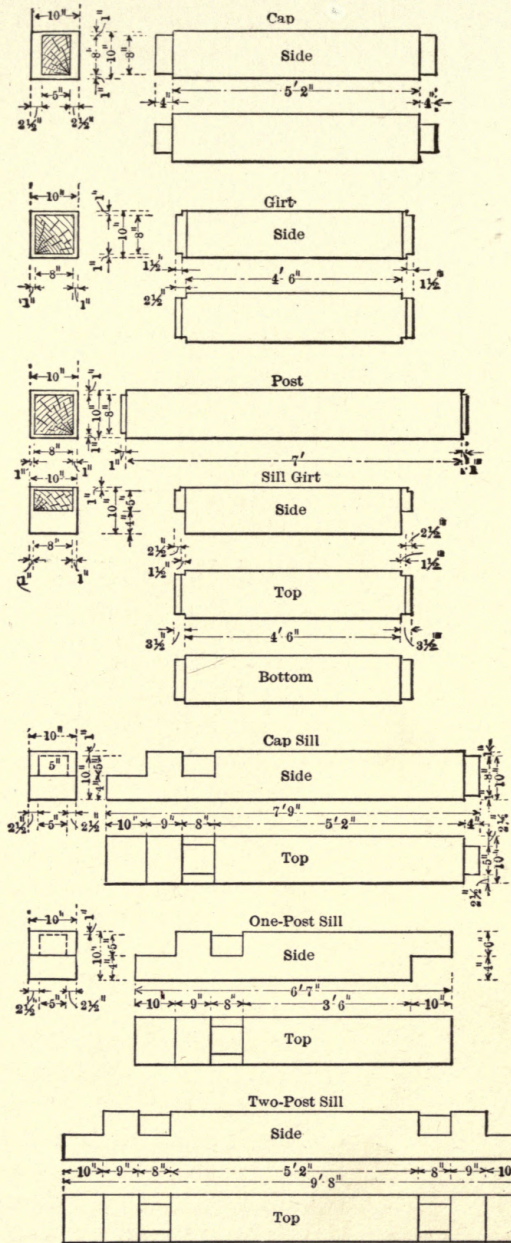

FIG. 56. — ANACONDA METHOD OF FRAMING. Details.

MINE TIMBERING
BY THE SQUARE-SET SYSTEM AT ROSSLAND, B.C.
BY BERNARD MACDONALD

MINE TIMBERING BY THE SQUARE-SET SYSTEM AT ROSSLAND, B.C.¹

BY BERNARD MACDONALD

IN mining operations, when the ore extracted exceeds a width of 12 or 15 ft., it has been found that the cheapest and only effective method of timbering is by the square-set system.

The system may be generally described as a rectangular skeleton framework of timbers, extending from wall to wall of the vein as exhausted, the different members of which are so framed as to stiffen and support each other, and equalize and distribute local strains after the manner of a truss.

HISTORICAL

The square-set system of timbering was invented by Philip Deidesheimer, while Superintendent of the Ophir mine, on the Comstock lode, in 1860.

In Monograph IV of the United States Geological Survey, "Comstock Mining and Miners," the following reference is made, which will be found interesting under this heading:

"At the 50-ft. level (of the Ophir mine) the vein of black sulphurets was only 3 or 4 ft. thick, and could readily be extracted through a drift along its line, propping up the walls and roof, when necessary, by simple uprights and caps. As the ledge descended, the sulphuret vein grew broader, until at a depth of 175 ft. it was 65 ft. in width, and the miners were at a loss how to proceed, for the ore was so soft and crumbling that pillars could not be left to support the roof. They spliced timber together to hold up the caving ground, but these jointed props were too weak and illy supported to stand the pressure upon them, and were constantly broken and thrown out of place.

¹ From *Proceedings of Canadian Mining Institute*, 1903, Vol. 6.

The dilemma was a curious one. Surrounded by riches, they were unable to carry them off.

"The company was at a loss what to do, but finally secured the services of Philip Deidesheimer, of Georgetown, California, who visited and inspected the treasure-lined stopes of the Ophir."

During Mr. Deidesheimer's engagement at the Ophir, all the principles of square-set timbering were evolved under his immediate supervision, and the wide and rich orebodies occurring in that mine were successfully extracted without the loss of ore or injury from caving by the use of this system. The system was then used in all the mines on the Comstock lode, and subsequently in all metalliferous mines elsewhere where the orebodies exceed a width of 15 ft., the extreme width that it is practical to timber by stulling.

The "square set" has undergone numerous modifications of detail in dimensions and the framing of its members in the various camps where it has since been used, owing mainly to local conditions, the dip of the vein, and the character of the orebodies and the enclosing rock.

VEIN CHARACTERISTICS AT ROSSLAND

In the Rossland mines, the ore deposits have widths ranging up to 100 ft. or more, and lengths of several hundred feet along the veins. The veins are sheer zone fissures, the vein-filling consisting of country rock, which is now found replaced, and cemented to various degrees of completeness by auriferous pyrrhotite and chalcopyrite.

The ore and the enclosing rock may be designated as extremely hard, and the veins dip at angles of about 70 deg. These conditions facilitate and simplify timbering, without, however, doing away with its necessity.

PRELIMINARY WORK

In stoping out these deposits, the work is begun at the level drives or drifts run in the vein, and continued upward in steps or stopes.

The first work in opening up an ore shoot or deposit preparatory to extraction consists of running drives or drifts through it from the level stations at the shaft, which are generally cut at

distances of from 100 to 200 ft. in depth below each other. Such drives may happen to be run along either wall of the vein, or through the vein at any point or distance (usually varying) from either wall.

These drives are considered as random bores, made longitudinally through the vein to determine, in a general way, its course or strike, and the behavior and characteristics of the ore shoot. They serve, besides, as preliminary thoroughfares for the traffic, drainage and ventilation necessary for the preparatory work of stoping, to be hereafter described.

As generally run in the LeRoi vein, the drives have widths of about 6 ft., and heights of about 8 ft., and require no timbering, owing to their comparatively small size and the hardness of the vein rock.

When it is decided to begin stoping on any new level, the first work done is to excavate the ore along the drives from wall to wall of the vein, making the excavation of sufficient height to receive the sill floor set of timbers, as the first series of square sets on the level is called, and to leave a space of 2 or 3 ft. over the set. This space serves to provide room for blocking and wedging the timbers to place, and to receive a layer of old timbers, which act as a cushion in preventing the possible breaking of the timbers by the masses of rock that must be blasted down on them, as the work of stoping out the ore above proceeds.

SILL FLOOR CONSTRUCTION

The sill floor is a framework, made of 10x10-in. sawed timbers, laid down on the working level in the orebody. They serve as the sills or foundation timbers on which the square sets are to be erected. It is, therefore, the first as well as the most important part of the square-set system of timbering.

Figure 57 shows the sill floor as laid down and ready to receive the sill floor set of timbers. The members of the sill floor consist of three pieces: the stringer, or long sill; the spreader, or short sill; and the butt spreader, or brace. These members, when repeatedly laid in duplicate, will make up a sill floor to any extent required by the size of the deposit.

The dimensions and details of the framing of these members are also shown in the figure.

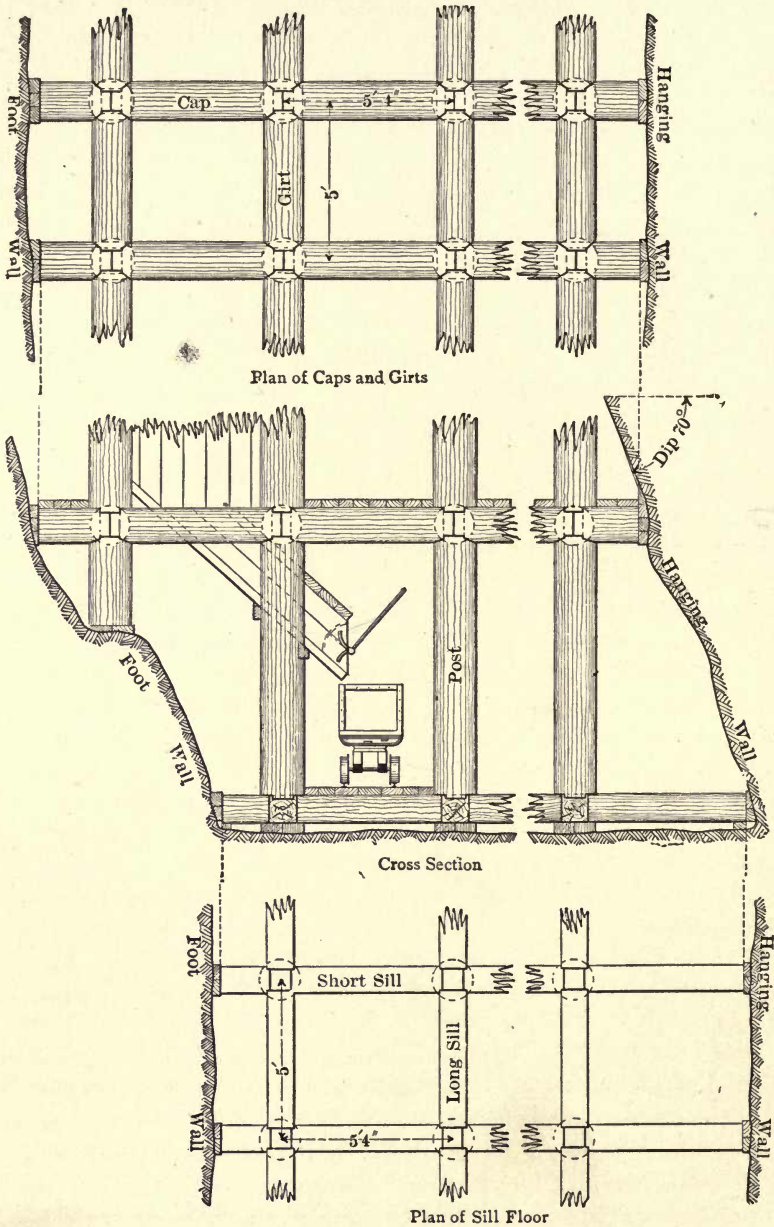

FIG. 57. — SQUARE-SET TIMBERING AT ROSSLAND, B.C.

The long sill measures 15 ft. over all, and is framed from a 16-ft. timber, which allows 6 in. to be cut from either end to square the piece and remove sun cracks.

The short sill, as framed, measures 5 ft. 4 in. in length, over all, three of which may be cut from a 16-ft. timber, if it over-measures a few inches, as it generally does, and the ends are sound.

The butt sill or brace is framed of varying lengths to suit the existing space, which generally varies owing to local bulgings or contractions of the vein. It is framed on one end exactly like the short sill, while the other is cut square or beveled to fit or butt against the wall-rock, from which it is wedged tightly to place against the long sills.

A description of the method of framing the sill floor set of timbers is not needed, as it will be fully comprehended by a glance at the figure.

In laying the sill floor, the long sills are set ends abutting flush against each other, and as nearly as possible parallel with the general strike of the vein, ignoring any local bulging of the walls.

The first sill is laid close and approximately parallel to the foot-wall, in which position it is leveled and held by blocking or butt braces; the other long sills are laid paralleling this one at proper distances apart, that is, 5 ft. 4 in. between centers. The cross sills fit on top of these, lying level with them, the ends being halved in framing to rest into similar halvings in the long sills, and to abut flush against each other and extend endwise from wall to wall of the vein.

When the long sills reach as near the hanging wall of the vein as desirable, they are braced from it by the butt spreaders or by blocking, wedged tightly to bring all the members into proper position. The philosophy of this design of the sill floor is as follows:

The long sill is made 15 ft. in length, so as to better sustain the superstructure of square sets erected on it when the ore upon which it rests comes to be stoped away. For instance, when the ore is being blasted from under the sill floor by the work of stoping coming from the level below, and the blasting tears away a portion of the ore upon which the sill floor rests, making an opening, as it generally does, of, say, 8x8 ft., the long sills would over-

reach such opening, and one or both ends would rest on the solid rock beyond. Nor would the short sills drop away through such opening, owing to the fact that they rest on the top of the long sills, as previously described and shown in the figure.

Through the opening thus made in the ore, the portion of the sill floor exposed would be supported by posts set on the timber sets in the stope below. Thus the long sill operates to allow the work of stoping out the ore upon which the sill floor rests to be safely conducted, if such portions of the sill floor as become exposed as the work proceeds are properly supported by posts from the timber work underneath.

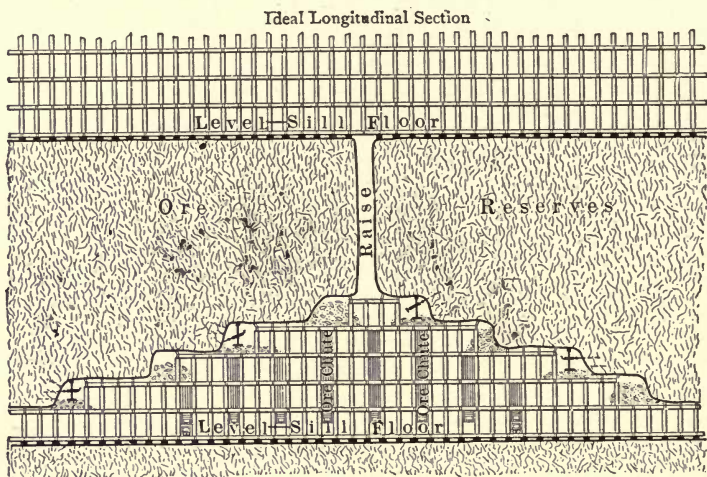

FIG. 58. — WORKING FLOORS AT ROSSLAND, B.C.

TIMBERS AND METHODS USED AFTER SILL FLOOR IS LAID

The first tier of square sets erected on the sill floor is known as the "sill floor sets." The assemblage of the framed timbers into square sets then proceeds upward, by floors, set over set, vertically, *pari passu* as the work of stoping exhausts the vein. The timber structure over any level is referred to in subdivisions as the "sill floor sets," "first floor sets," "second floor sets," and so on until it reaches the level above and catches up and supports the sill floor on that level.

This method of reference to the timbering as it advances

carries with it the data for a general calculation of the portion of the vein exhausted over a level, as each set of timbers in place indicates that 9 ft. vertically and $5\frac{1}{2}$ ft. horizontally of the vein are exhausted, 9 ft. being the bare height and $5\frac{1}{2}$ ft. the width of space required for a set of timbers. And each square set in place indicates that 24 tons of vein matter have been extracted.

Aside from the sill floor, all the timbers employed in the square-set system, except the planks for floorings and chutes, are framed from round logs. These logs are preferably of red fir, it being the strongest native timber, but pine, spruce and tamarack may be used. When cut in the woods, the logs are peeled and

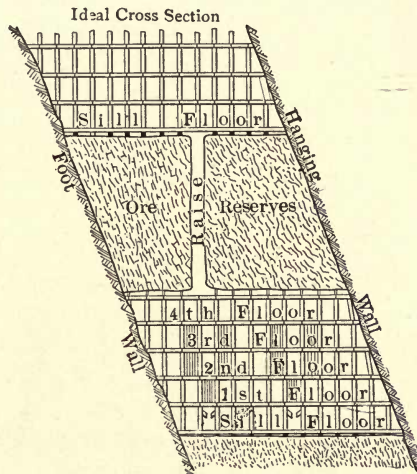

FIG. 59. — WORKING FLOORS AT ROSSLAND, B.C.

allowed to season for a period of from six to twelve months, during which time they lose about one-third of their green weight, which is a very important advantage in subsequent handling. In diameter, they range from 12 to 20 in., but generally average about 16 in., and are sawed in lengths of 16 ft. 6 in.

The logs may be framed by hand or with machine saws into the various members of the square set, as follows, viz.: posts, caps, girts or braces, and butt caps. Like the members of the sill floor, these members may be duplicated to any extent required by the size of the excavation to be timbered.

The posts as framed are 8 ft. 2 in. over all; the caps are 5 ft.

4 in., and the girts or braces are 5 ft.; the butt caps, like the butt spreaders on the sill floor, are cut in varying lengths to suit such spaces as may exist.

The details of framing the logs into members of the square set are plainly shown in Figs. 57 to 63, and need no further description. The philosophy of this method of framing the timbers is that the cap pieces of the various sets form continuous stringers of timbers running horizontally from wall to wall of the vein, no matter what this distance may be. Such stringers offer the end grain or greatest strength of the timbers to the walls, from which the greatest strains are generated. The posts and girts rigidly support the stringers thus formed of the several cap pieces in true horizontal position, bearing on the joints from right-angled directions, while the cap pieces and the girts support the posts in true vertical position.

The whole framework forms a strong, rigid structure, capable of indefinite extension upward and longitudinally as stoping proceeds, allowing at the same time for any expansion and contraction in width to suit such irregular widths of the vein as may occur.

Besides the functions of the various members of the square-set system to support each other in the manner described, that of the cap pieces is to receive directly and sustain the strains coming from the walls of the exhausted deposit, while that of the posts is to support the vertical weight coming from the undercut ore deposit and the broken ore lying on the floors, but strains coming from any direction are distributed over all the members of the set.

The system possesses, to a considerable degree, the qualities of a truss, and makes it possible to extract all the ore of any deposit and effectually secure the enclosing walls from caving in. When the framework comprising the sets is erected, a floor, consisting of 3-in. plank, is spiked down on the caps of each floor set. These are the working floors on which the miners operate the machine drills, in the method shown in Fig. 58. When the ore is dislodged from the vein by blasting, it falls on these floors, where the waste or second-class ore may be sorted out from the shipping ore. The shipping ore is shoveled into chutes which are built of 4-in. plank spiked to the timber framework and carried upward with the square sets, as shown in the

figures. The second-class ore, or waste sorted out, may be stored temporarily or permanently in the framework of the timbering, from whence it may be drawn off at any time through chutes, should removal elsewhere be desired.

Figures 58 and 59 are ideal longitudinal and cross-sections illustrating the method of timbering and the work of stoping as it is carried on between the levels. The original position of the level drive, as already stated, furnishes the point from which the excavation of the vein matter for the sill floor is commenced.

The step method of excavating the ore is shown in Fig. 58, where stoping is proceeding in double-headed steps, each step excavating the ore from wall to wall and having a vertical height of 9 ft. in the clear, which allows of the erection of one floor of timber sets, which in turn provides the scaffolding from which the miners may attack the ore above.

In stoping out the ore on any level, the ordinary method is to keep the sill floor at least 30 ft. in advance of the first floor, and it about 30 ft. in advance of the second, and so on, as is shown in Fig. 58. One machine drill, or generally two, in case the vein is wide, are assigned to work the two opposite headings of any floor, going in opposite directions, working on each heading alternately. When one face is drilled and blasted, the machine drills are changed to the opposite face, and the shovelers pass the broken rock into the chutes, or sort it, if sorting is required. When the ore broken is thus removed from the face the timber gang erects another unit of timber there, and the stope is again in readiness for the machine drills, which have by this time finished drilling on the opposite face.

Generally the step method of stoping proceeds in opposite directions from a raise run through the orebody between the levels, as shown in Fig. 59. The framed timbers are delivered in the stope by dropping them down through this raise or hoisting them from the level. Sometimes the framed ends of the timbers are injured by dropping them through the raise, but as a rule no material injury is done to them, while the time gained by this method is a very important factor in cheapening the cost of timbering, compared with hoisting piece by piece from the sill floors underneath.

PER TONNAGE COST OF SQUARE-SET TIMBERING

After the sill floor is laid and the framework started, a square set, which is made up of one post, one cap, and the brace, consumes 18 ft. 6 in. running feet of logs.

The logs peeled and seasoned cut measuring 16 ft. 6 in. cost \$1.20 each delivered f.o.b. the cars at the works, or about 8c. per running foot. Therefore, the 18 ft. 6 in. required for the set would cost \$1.48, or say \$1.50, unloaded in the framing shed, provided the logs are not cut to waste in framing, which may be avoided with a little care and foresight.

The cost of framing the pieces comprising the set would be about \$0.553, when framed by hand labor, carpenters being paid \$3.50 per day of nine hours.

COST DATA PER SQUARE SET, HAND FRAMED

Material. — A log, measuring 16 ft. 6 in., costing \$1.20, cuts into two posts, or three caps, or three braces; therefore:

Material in one post costs.....	\$0.65.0
Material in one cap costs.....	0.43.0
Material in one brace costs.....	0.43.0
Total cost of material in one set is, say.....	\$1.50.0

Labor. — One carpenter (wages \$3.50) frames per day:

About 21 posts, costing each.....	\$0.16.7
About 21 braces, costing each.....	0.16.7
About 16 caps, costing each.....	0.21.9
Total cost for framing.....	\$0.55.3
Total cost of labor and material in set.....	\$2.05.3

The details of cost of the individual members of the set framed on the surface, ready to go into the mine, are therefore as follows:

1 post costs, for....	{	Material	\$0.65.0	}	\$0.81.7
		Labor	0.16.7		
1 cap costs, for....	{	Material	0.43.0	}	\$0.64.9
		Labor	0.21.9		
1 brace costs, for....	{	Material	0.42.0	}	\$0.58.7
		Labor	0.16.7		
Making the total cost.....					\$2.05.3

The costs next attaching to the square set, or unit, of this method of timbering are:

Lowering into the mine.....	approximately	\$0.10
Delivering to place required.....	approximately	0.10
Labor in erecting.....	approximately	1.50
Incidental material, such as blocks, wedges, tools, nails.....	approximately	0.10
Cost of sill floor averaged over 11 sets between levels		
100 ft. apart.....	approximately	0.15
		<u>\$1.95</u>

These costs last given above may vary greatly, being increased or decreased with the completeness of the facilities for handling the framed timbers; the cost of the several items as stated may vary accordingly from time to time, but the total will be about the average cost, and will closely approximate that of carefully supervised operations. Therefore, from the foregoing it will be seen that the cost of the square set placed in the mine will come down, as follows:

Total cost of labor and material, as above.....	\$2.05.3
Labor and material when set is in place, as above....	1.95.0
Total cost, say.....	<u>\$4.00.0</u>

When framed by machine saws, the cost of framing a square set does not exceed 30c., including the cost of power, as against 55c. by hand, a difference of 25c. per set. Therefore, if the framing is done by machinery, the cost of a set in place would be \$3.75 as against \$4 as shown above when the framing is done by hand work.

The per tonnage cost for timbering by this method works out as follows: The average space to be excavated for each square set is 5.3 ft. wide by 5 ft. long, by 9 ft. in height, or 240 cu. ft. The Rossland ores, being heavily impregnated with iron and copper pyrites, yield a ton of 2000 lb. for each 10 cu. ft. of ore in place; therefore, from the 240 cu. ft. of vein required to be excavated for a set of timbers, the yield will be 24 tons. If the timbers were framed by hand the cost of timbering, so far as described, would be about \$0.17 per ton; if by machinery, \$0.15.6, a difference of \$0.01.4 per ton in favor of the machine-framed sets.

In addition to the costs above tabulated, there still remain the costs of the chutes, floors, ladders, and railings necessary for the convenience and safety of the miners and the passage of ore and supplies. These require, on an average, about 100 ft. of lumber, board measure, per square set, which, at \$11 per 1000 ft., would add for the lumber \$1.10, and for placing it, say \$0.10, or a total of \$1.20 to each square set, which would then cost, in the

case of hand framing, \$5.20, or a total cost of \$0.21.6 per ton of crude ore; and in the case of machine framing, \$4.95, or a total cost of \$0.20.6 per ton of crude ore.

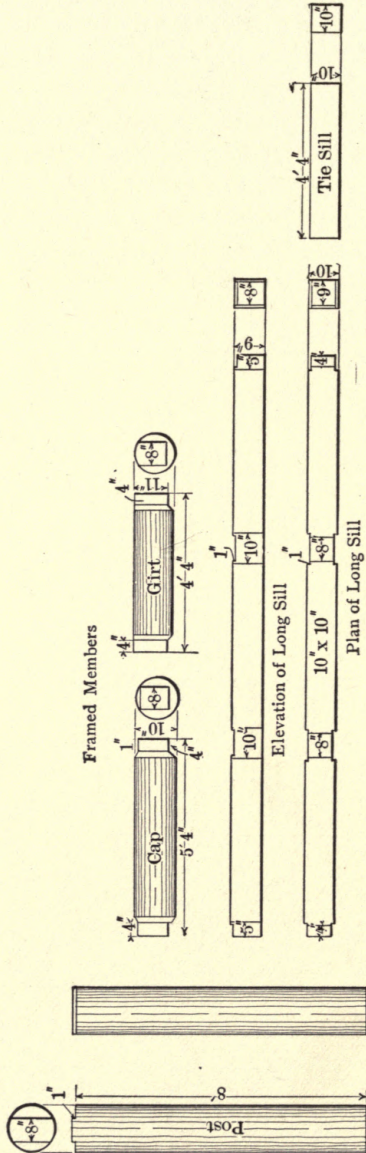

Fig. 60. — SQUARE-SET TIMBERING AT ROSSLAND, B.C. Details.

INCIDENTAL COSTS

The cost of timbering, per ton of ore shipped, would be greater than the figures given above in proportion to the quantity of waste or second-class ore that would be sorted out from the crude ore extracted.

In the Rossland mines about 20 per cent. of the ore mined is sorted out and goes to the second-class ore dump to await profitable treatment, expected to come in the future. Deducting 20 per cent. of the 24 tons of crude ore in a square set, there would remain 19.20 tons as the shipping ore, against which the total costs of the square set as above, \$5.20 or \$4.95 as the case might be, would have to be charged. This would raise the per tonnage costs on the ore shipped to about \$0.27 and \$0.26 respectively.

Where there is a reasonable expectation that the second-class ore will eventually pay a profit after suitable treatment, it would be only fair to charge a pro rated cost of the timbering to it, and the cost would then remain \$0.20.6 and \$0.21.6 per ton as above.

In cases where, on account of bad ground, angle bracing, bulkheading, or cribbing and filling would be required, the per tonnage cost would be still further increased, but to a comparatively small extent.

LIMITATIONS OF THE SQUARE SET

The limit of the capacity of the square-set system as already described, without any reinforcing devices to withstand the pressure that may be exerted on it by the enclosing walls of an orebody when that orebody is extracted, may be reached.

This limit depends on the nature of the walls enclosing the deposit, and the extent of the excavation. If the wall-rocks are solid and do not swell on exposure to the air and dip at a high angle, the orebody may be extracted between levels, say 100 ft. apart and for a length of 200 or 300 ft. along the vein, and the pressure likely to be exerted by the walls will be sustained by the skeleton square set without reinforcement of any kind.

If, however, the vein dips at a low angle, and the wall-rocks are decomposed, or of a talcose or serpentine character, and disposed to swell, the pressure that might be exerted on the timbers, when even a comparatively small excavation of the

orebody has been made, may cause them to crush, "jack-knife," or collapse, allowing the wall-rocks to cave in and close up the stope. When the members of the square set become squeezed out of the truly right-angled position which they should occupy, their capacity to resist wall pressure or strains from any direction is practically *nil*.

When, owing to wall pressure or imperfect erection of the sets, "jack-knifing" of the square sets results, the cave-in which sooner or later will follow, with disastrous consequences, may be prevented by either bulk-heading, cribbing, or filling the skeleton framework of the timbers.

The cost of the foregoing methods of reinforcement, which are the only practical ones that can be successfully used in bad ground, cannot be given with any general degree of accuracy, as that is so much affected by the local conditions in each case.

A general idea of what the cost is likely to be may be gleaned from the description following:

REINFORCEMENT METHODS

Angle bracing. — If, after the square sets are properly erected in place, the members manifest an inclination to swing out of the right-angled positions they originally occupied to each other, this tendency may be arrested and prevented by a system of angle bracing. This consists of placing diagonal braces made of round or square timber on the sill floor and against the foot of the posts, and leaning the heads so they will fit snugly against the top of the posts underneath the caps or girts, as the case may be, of the next adjacent set. The head of this diagonal brace should lean in the direction from which the pressure comes. This method is illustrated in Fig. 62.

Cribbing. — When the square sets manifest a stronger tendency to swing than in the case referred to, the collapse threatened may be prevented by crib work. This consists of crossing alternate layers of round or square timbers of any convenient size between the posts of the sets until the space between the sill and cap is filled, as shown in Fig. 63. This crib work may extend from wall to wall through two or more rows of sets if required, and the spaces between the sets thus cribbed may be filled with waste rock, but this is called "filling," and will be referred to under that heading below.

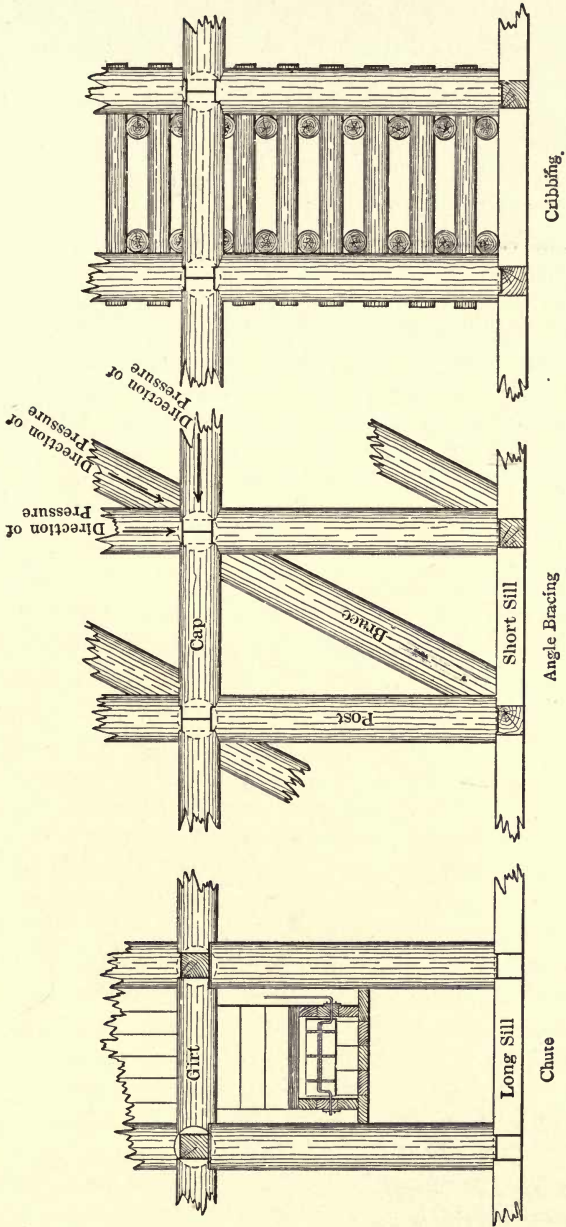

FIGS. 61-63. — SQUARE-SET TIMBERING AT ROSSLUND, B.C.

Bulkheading. — This method of reinforcement consists of placing timbers closely together in much the same way as the crib work above referred to, and wedging them tightly between cap and sill.

Filling. — This method consists of filling the spaces between the members of the square set with any material such as waste rock, earth or sand. When the filling is done it is retained within proper bounds, and the necessary passageways are kept open through the timbers by building crib work around them as described.

Waste rock for filling purposes is generally secured from the development or dead-work that is being prosecuted in other sections of the mine, but where a large quantity is required, it is often found necessary to mine it specially for that purpose, or draw it from the waste dumps on the surface. About 8 cu. yd. of material are required to fill the vacant space of the frame of a square set, and the cost of such filling will be the cost of obtaining and placing such material, together with the crib work required to retain it within proper bounds.

GENERAL REMARKS

The square-set system of timbering is used successfully and exclusively in all mines where large deposits of metalliferous ores occur.

Where favorable conditions, such as railway transportation and a moderate supply of timber, exist, it is comparatively cheap. If care is taken in the construction of this system in the mine, it ensures that all the ore existing may be extracted without injury to the workman or the mine. Round logs or sawed timbers of any dimension, ranging from 8 in. upwards, may be used, but the sizes are governed by the economic conditions and mining requirements.

In the mines of Rossland, the round logs or timbers used for the square sets cost \$1.20 for each log 16.5 ft. in length f.o.b. the framing shed at the mine. These logs are cut in the state of Washington, and delivered over the Spokane Falls and Northern Railway on flat cars, over distances ranging from 45 to 75 miles, each flat car being loaded on an average with 60 logs. The unloading at the framing shed is done in a few minutes by cutting

off the retaining standards on the flat cars, and allowing the logs to roll off on the storage platform.

Of course, where wagon transportation is required from the railway terminus, the expense will be correspondingly increased.

In every mining camp there will be more or less variation in the method of framing, and in the cost of the square sets in place, also in the tonnage of ore to be extracted from the space occupied by each square set.

Where the dip of the vein is at a flat angle or the walls are bad, shorter posts than those described herein will probably be more advantageous; the more vertical the dip of the ore deposit, the longer the posts may be, and *vice versa*.

Where sawed lumber is comparatively cheap, 3-in. plank is preferable to lagging poles for floors, on account of the better floor it offers for shoveling, and the fact that it may be removed and re-used.

MINING AND TIMBERING
IN LARGE OREBODIES IN BRITISH COLUMBIA AND
MICHIGAN

BY NORMAN W. PARLEE

METHODS OF MINING AND TIMBERING IN LARGE ORE-BODIES IN BRITISH COLUMBIA AND MICHIGAN ¹

BY NORMAN W. PARLEE

THE method of mining to be adopted in any particular mine depends upon a number of important considerations. Among these may be mentioned the size and attitude of the orebody or deposit, the hardness and rigidity of the ore and adjacent rock, the quantity and quality of timber available and its cost, the price of labor, and the value of the product to be mined. Generally speaking, if a narrow vein is to be worked, stull timbers are used, the limit being a width of about 15 ft. As the vein widens beyond this, stulls are out of the question, and another system must be adopted. The method then employed may be the square-set system, or a filling method, except in case of soft ore, when a caving system may be followed. There are a great many modifications of all these systems to suit circumstances and conditions, and it is the intention in this paper to describe and discuss them as carried out in those mines in which the writer has worked, and in which he has become more or less familiar with the methods in successful operation.

The names of the mines treated, and location, are as follows:

Le Roi mine.....	Rossland, B.C.
Old Ironsides	Phoenix, B.C.
Baltic mine	Baltic, Mich.
Atlantic mine	Atlantic, Mich.
Barnum mine	Ishpeming, Mich.
Section 16	Ishpeming, Mich.
Soft Ore Hematite.....	Ishpeming, Mich.
Queen mine.....	Negaunee, Mich.

In nearly all these mines the methods used apply principally to mass mining in large bodies of ore. The one exception is the Atlantic mine, which has a narrow deposit, and is mined entirely by the old-fashioned stull method.

¹ From *Transactions of Canadian Society of Civil Engineers*, Vol. 18, 1903.

LE ROI MINE, ROSSLAND, B.C.

In this mine there are one or more veins or ore shoots of varying width and carrying the minerals pyrrhotite, chalcopyrite and iron pyrites, and mixed with these more or less disseminated gold. It is the gold, however, that affords the principal value of the ore, and without it there would be no Rossland. The vein is of a pockety nature and some of the pockets are of very large size. The dip is about 70 deg., and an incline shaft was sunk at about this slope. As depth was attained it was found that the vein pitched a little steeper, and the shaft was given a steeper pitch also, thus forming what is called a "knuckle" in the shaft. This knuckle afterwards became a source of considerable trouble, because, at high speeds, the skip was liable to leave the track.

At intervals of 100 ft. drifts were run on the lead, and the deposits thus opened up. The first shaft had three compartments timbered with the ordinary square shaft sets. Sinking was carried on with three shifts of miners working eight hours each, and the rock broken was hoisted to the level above with a bucket and air hoist. As the shaft became deeper the ore and rock were hoisted by skips, run on the balanced principle. A pentice of about 15 ft. of rock was always left in the shaft at each level, and served as a protection to the shaft men working below. It was located under the two hoisting compartments, and connection was made below by a passage at the side. Each drift was usually excavated before being timbered.

At each level, drifts were run on the vein in the ordinary manner, dimensions being 6x9 ft. In the earlier workings the tracks were laid very poorly, and were often the cause of a great deal of trouble and delay, when a large output was desired. But as time passed improvements in this, and many other respects, were inaugurated, and the tracks were laid to a grade of from 7 to 10 in. per 100 ft. Track laying is a very important matter in the economy of a mine, and a good track will always pay for itself many times over. The tracks should not only be good, but there should be plenty of them, placed so that they will be close to the rock to be removed. In drifts movable lengths of 8 to 10 ft. should be used. This saves shoveling to a long distance, by placing them in position as soon as there is room,

and enables the mucker to work to advantage, until there is sufficient space for the ordinary 16- to 20-ft. rails. The rails are laid on 4x6-in. ties, 3 ft. in length, and placed about 4 ft. apart, the rails weighing 16 and 20 lb. to the yard. The waste rock encountered in development was trammed to the shaft and sent

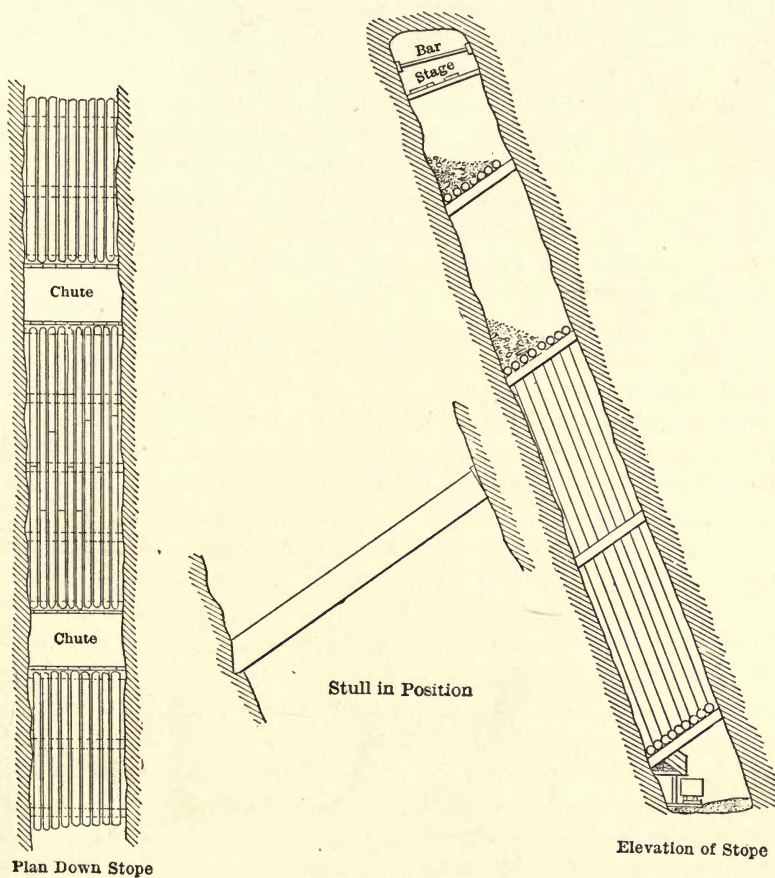

FIGS. 64-66. — STULL TIMBERING, LE ROI MINE.

to the surface, though now most of it is filled into the stopes of the upper levels.

When the miners began to stope on any level, an upright post was rigged, and the holes pointed upward and backward. On a narrow part of the vein a cross bar was often employed,

which enabled the muckers to tram beneath from another part of the level, while drilling operations were being prosecuted. Whenever convenient, however, the miners prefer to rig upright, as they can drill more advantageously from that position. As they climbed higher on the vein, hitches were cut in the foot-wall, and stulls were put in from foot- to hanging wall. One end was fitted into the hitch, and the other end cut with such a bevel that it fitted against the hanging wall, which had been previously faced if necessary. (See Fig. 65.) The greater the weight coming on the stull, the more securely it would remain in place. These stulls were placed tightly in position, and wedged if necessary or possible. If there was any liability of their being knocked out by blasting, a hitch was also cut in the hanging wall. Stulls were used to form floors to work from at intervals of nearly 20 ft., and such a distance apart horizontally that the lagging placed upon them would not be broken by the blasts above. They were also put up against any bad ground that required them. The lagging used on the stulls consisted of round poles, and plank chutes were run up the stope at convenient intervals.

An idea of the stope and chutes may be gathered from Figs. 64 and 66. A cross bar and stage is shown in Fig. 64, but usually most of the work is done from the broken ore resting on the stulls, and an upright post is rigged, either on this ore or on benches on the foot-wall.

But where the orebody widened, stulls could not be used. Here the stope was started by enlarging the drift to the total width of the deposit, and a face obtained right across the vein. In one case the width varied from 40 to 80 ft., and, as a back or roof of this size would be dangerous to work under without some support, the timber had to be quite close to the face. When the muck was removed mud-sills were laid down, upon which the sill posts were erected. These sills were carefully placed, and tamped with fine dirt. They were braced apart by cross ties, and had a length of 10 ft. 8 in., or two sets. The framing and manner of laying them is shown in Fig. 67. At first the sill floors were not planked over, but later it was seen that a plank floor was economical to shovel from, as often there would be rock tumbling down, or breaking through from the floors above.

On one level in the Le Roi, the 700-ft. level, there were no fewer than eight machines working at the same breast simulta-

neously. This meant that the rate of advance was very rapid, and difficulty was experienced in keeping the timber close enough to the face. Two parallel tracks were laid to remove the ore, one along the foot-wall side and one along the hanging wall side, and a large gang of muckers and timbermen became necessary. When the sills had been laid down square sets were erected upon them, and securely braced or spragged. Spragging a set of timber requires considerable experience on the part of the timberman. Spraggs are pieces of round lagging, cut square at each end and of varying length, and placed between the ground and

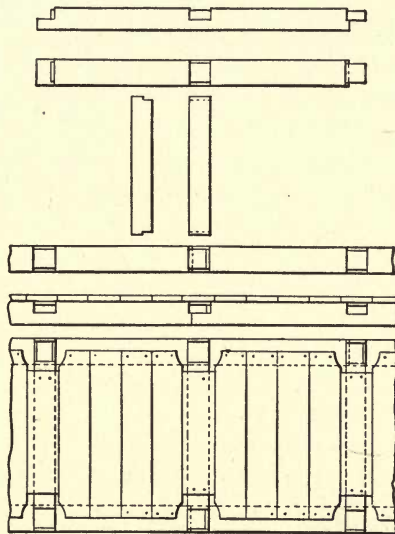

FIG. 67. — MUD-SILLS AND TIES, LE ROI MINE.

the caps or ties, as the case may be, and securely wedged. They serve to keep the sets rigidly in their proper position, and thus prevent them from falling down during concussion after blasting.

The details of the square sets are shown in Fig. 68. These were at one time framed by hand, but now a framing machine does the work. The sets are shown in position in Fig. 69. This is a view of a section across a rather narrow part of the vein. One post on the foot-wall is placed in a special manner to avoid the necessity of cutting a large hitch in the rock, which is very hard. A hitch is often made when it can be cut without too much trouble. On the hanging side an extension cap is shown,

no hitch or support being made for the end of it. The top "butt" cap on the hanging side is supported at the end by a heavy pole instead of a post. The plank floor, lagging and spraggs are shown at the top.

The posts used in the Le Roi ranged from 12 to 24 in. in diameter, the caps 12 to 15 in., and the collar braces or ties somewhat smaller. In the old days it was the custom to cover the caps

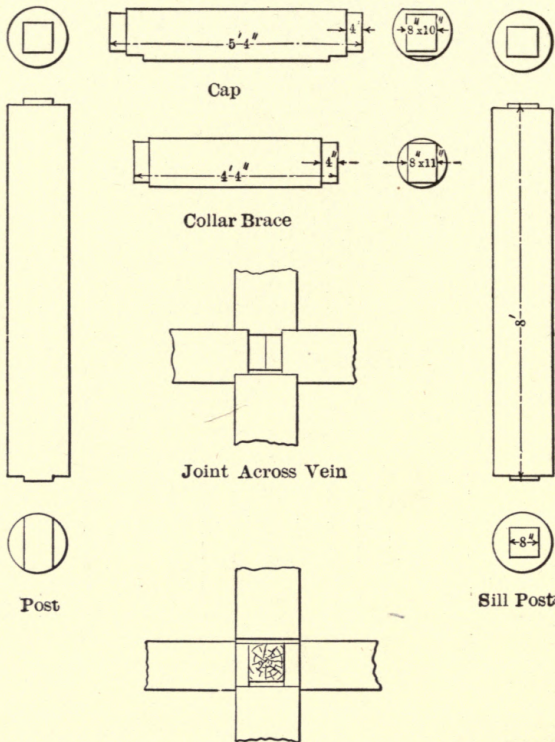

FIG. 68. — DETAILS OF SQUARE SETS, LE ROI MINE.

with round lagging, 16 ft. long and up to 7 in. in diameter. They thus reached over three sets, but were difficult and awkward to handle, on account of their length. After several years of this inconvenience it was decided to cut them so they would reach only two sets. The lagging was then brought to the mine in lengths of 20 ft., and they were sawed in half on the surface. A double tier of lagging was used, one tier being laid on the caps and the other at right angles to them. Still later in the history

of the mine 3-in. planks in 5-ft. lengths were laid on the caps, and a few rough holes placed on top of them, to prevent the plank being broken by the blasts. These planks were spiked with one spike in each end, and served to stiffen the timber considerably.

When the excavation on the level had advanced a reasonable distance, say about 60 ft., another floor was started on top of the timber. Overhand stoping now commenced and rock or ore was broken much more readily than on the sill floor, as it had a better chance to break, there being more free surfaces. Holes

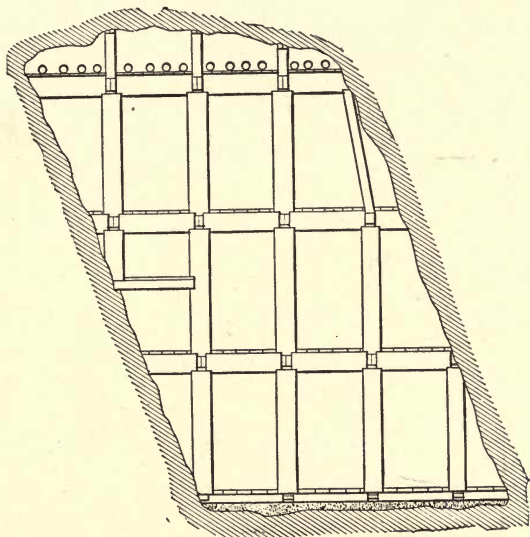
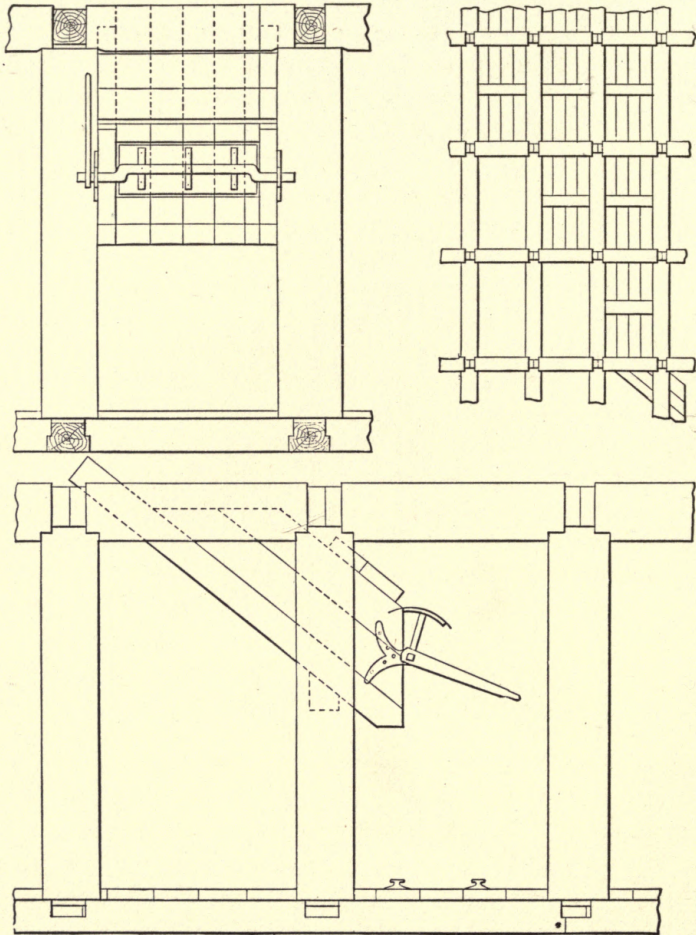

FIG. 69. — SQUARE SETS IN POSITION, LE ROI MINE.

were drilled in a face about 7 or 8 ft. in height, and placed so as to bring the ore down to the best advantage, viz., enough holes were drilled and enough powder used to break the ore to convenient size for economical handling. If it were broken too fine it would take too long to shovel into chutes, while if it came down in the form of large boulders it was necessary to blast. The sizes most conveniently handled were lumps weighing from 25 to 50 lb., which could be rapidly and easily thrown or pulled into chutes. The holes were generally drilled in the direction of the vein or orebody, and not across it, the depth being about 7 ft. At each set-up the miners moved across the face from foot to

hanging, or *vice versa*, as the case might be. In this way the muckers cleaned out the broken ore behind, and, as soon as there was room, the timbermen proceeded to put up the timber.

To get out the ore, chutes were built in every other set, or



FIGS. 70-72. — VIEWS OF CHUTE, LE ROI MINE.

every third set at most. The bed pieces were made of 8x10-in. timbers, placed at proper slope for the rock to roll down, one end being on the collar brace, and the other supported by a cross piece inserted between the posts, and high enough to enable the one-ton ore cars to pass beneath. Figs. 70 and 72 show a front

and side view of a chute respectively. The chute door or gate consisted of a semicircular sheet-iron plate, with suitable stiffening to prevent deformation, and a lever attached by which to operate it. By means of these chutes properly made, and with dry ore, the car could be filled in a very few seconds.

As more floors were constructed above, the chutes were carried up the full size of a set, by spiking plank 8 ft. 8 in. in length on the caps and collar braces. To bring them closer to the ore, as in a large stope, the chutes were expanded to take in two, three, and even four or five sets. (See Fig. 71.) The chute planks were all placed vertically, and where it became necessary a bottom of short lagging was made for the rock coming from above to fall upon. A stiffening was made for the chute planks by a cross brace between the posts, half-way up and well spiked. In a wide stope, two rows of chutes and two lines of track were constructed. By this means the muckers were enabled to get the ore into the chutes without being compelled to throw it far, or to use wheelbarrows or any other device.

While any level was being developed a winze was sunk from the level above to provide ventilation. These winzes were always located in the stopes, and provided a sort of chimney by which the smoke had a chance to escape. They were also used as an easy route by which timber could be lowered to the upper floors, and later, when the ore had been all removed, or nearly so, waste rock was run in through them to fill up the stope.

As more and more floors were attacked and carried forward, more faces were worked simultaneously. Care had to be exercised in regard to approaching too near the front line of timber. The blasts might jar the timber, and possibly cause it to throw forward a few inches, even if they would not knock it down. When square sets have been disarranged in this manner, it is a very difficult matter to force them back into position again. I have had occasion, as a timberman, to use jack-screws in cases of this kind, and to spend considerable time on work which, with a little more caution on the part of the miners or the management, would have been unnecessary. One machine at a face and one machine at every other floor appeared to be a good method. This allowed the men of the timber gang to put up a line or two of timber on the intermediate floors, and they were not interfering with either the muckers or miners.

An idea of the method of attack in a stope may be gathered from Fig. 73. In this view, however, I have unfortunately shown the limit of advance on each floor rather than the actual working condition. As illustrated in the diagram it would be necessary to carry the lower faces ahead to allow a chance to work on the upper ones.

As the floors became more numerous and farther and farther away from the winzes, some method had to be adopted to get the timber into the stopes more easily, quickly and economically. An excellent plan was introduced in the Le Roi in the large stope on the 700-ft. level. A track was laid the full length of the stope

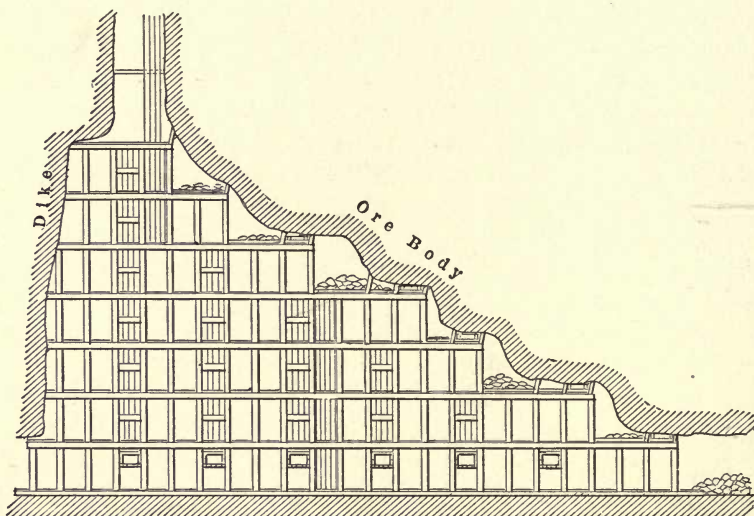

FIG. 73. — GENERAL SCHEME OF STOPE, LE ROI MINE.

on the first floor above the level, up out of the way of the tramming tracks, and a truck carrying a small air hoisting engine placed on it. From the drum of this hoist a manila rope was carried up a special timber chute, over a pulley on an upper floor, and then down the chute to the level below. Here the timber was attached with a hook and half hitch, and hoisted to any floor desired. An idea of this arrangement may be gathered from Fig. 73, in which one timber chute is shown beside an ore chute. The timber chutes were made of 2-in. planks, spiked to the collar braces, and inclined with the vein. They were erected every 80 ft. or less, and were convenient for hoisting drills and

machines, as well as timber. The timbers could be readily dragged to any place desired by means of the "come-alongs," which were a pair of hooks attached to the center of a small pipe $3\frac{1}{2}$ ft. in length. A man on each end of this pipe could drag a post anywhere over the floor.

The ore was not sorted in the mine, but sent to the surface to be treated there. It was trammed to the shaft and dumped into large pockets from which the skips were loaded. The tracks at the shaft were laid directly over the pockets, and the ore was dumped from the car between the rails, or at one side of them. These pockets were capable of holding a good many tons, so that, if anything happened to the hoisting apparatus, the trammers could still work away, and fill the pockets. In the new shaft, which was put through by means of raises from each level, pockets were made with a capacity of about 200 tons.

From this somewhat detailed description it will be seen that a great deal of timber is used in this mine. The timber is not used merely to hold up the hanging wall and roof, but principally to furnish a convenient method of reaching all the ore, and to prevent loose slabs and boulders from dropping on those who must work beneath. The workings are kept closely timbered, and thus liability of accident is reduced. No staging is needed in rigging machines, the muckers have a good floor to shovel from, and chutes are handy and convenient, more so than could possibly be the case in any other mining method.

By this system all the ore is taken out between levels. The sills of one level are caught up from beneath, and timber connections made with the level below.

When a stope or level is worked out the only timber saved is the rough lagging and plank flooring, which is readily torn up and used again. Waste rock from development work in other parts of the mine is dumped down, and the old stope gradually filled up. This rock is brought up from the lower levels on cages in the new five-compartment shaft. No great attempt is made, however, to fill the stopes.

OLD IRONSIDES MINE, PHOENIX, B.C.

In this mine and the adjacent Knob Hill, we have a still wider and larger orebody than at any point in the Le Roi. Not

only is the deposit of immense size, but the grade of the ore is much lower, necessitating a much lower cost of extraction, in order to mine it at a profit. To accomplish this a large output is essential, and cheap and rapid means of handling it, from breaking the ore down until it finally reaches the smelter.

The ore is mined in three ways in these deposits:

- (1) By open cuts,
- (2) By the milling or "glory hole" method, and
- (3) By the ordinary overhand stoping with the use of square sets.

The open cut was on a level with the railroad track, and a tramway was built with an incline to enable a small hoist to bring the ore up high enough to dump into the railroad cars. This is quite an ordinary method and needs no further comment, the ore being broken down in the usual way. Later, however, when a considerable excavation had been made, a steam shovel was used, which handled rock of much larger dimensions. Boulders too large to go into the bucket were picked up by means of a chain. They were loaded either directly into the shipping cars, when the ore was crushed at the smelter, or into small wooden cars, and taken to the crusher first by horses, and at the present time by a small locomotive. Three steam shovels are now at work for this company in their low-grade orebodies, and they will tend greatly towards solving the problem of decreasing the cost, and, at the same time, largely increasing the shipments.

The milling or "glory hole" method also applies more particularly to the Knob Hill than to the Old Ironsides Mine. It consists essentially in driving a tunnel into the deposit to be excavated, as low as can be conveniently worked without the sides caving in, and then a raise to connect with the surface. At the bottom of the raise a very substantial chute is constructed from which the ore can be readily withdrawn into cars. Operations then begin on the surface and the ore is milled or broken down, being blasted into the raise. Suitable faces and benches are soon established, and a better command obtained of the size of the rock going down the chute or raise. Very deep holes are drilled and very heavy blasts set off, thus breaking the ore quite rapidly and economically. The benches are arranged in such a manner that a great amount of the rock rolls down into the chute, which is always partially filled, without much handling.

The advantages of this method are as follows: practically no expense for timber; no bad air to work in and hence no time lost; few drill holes needed and comparatively little powder used; the ore handled mostly by gravity.

The disadvantage is that there is a limit to the depth at

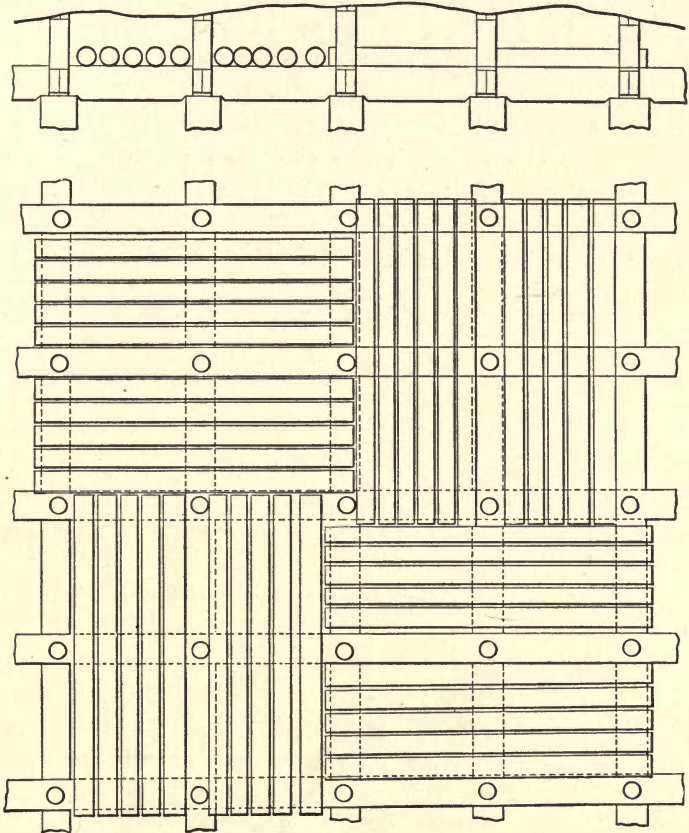

FIGS. 74 AND 75. — LAGGING ARRANGEMENT, OLD IRONSIDES MINE.

which the ore can be excavated, because of the caving or falling in of the sides.

On the deeper levels of the mine the usual method of underground development was carried out. The system of mining the ore was very similar to that in vogue in the Le Roi, which has been already described. The timbers, however, were stouter, and the method of lagging was different. In arranging the lagging

the object was to place it in such a way that the broken ore could be rolled into the chutes with the least possible amount of shoveling. To accomplish this, lagging about 10 ft. long was laid on the caps, close together, and, if the poles were weak, perhaps a double layer. A space two sets square had the poles laid parallel, and the adjacent squares were poled at right angles to these. The caps and collar braces were of the same dimensions, hence it did not matter which way the lagging was arranged. In this way the poles had a good support at both ends, because they reached well over two 5-ft. sets. When it was desired to remove the muck, all that was necessary was to move a pole so that the ore could drop through. As it rolled down, with the aid of a pick or bar, another and another pole could be rolled from beneath it. In this manner the writer has rolled into the chute 40 or 50 tons in four or five hours. Any very large boulders, of course, were smashed with a sledge hammer. Fig. 75 is meant to show the arrangement of the lagging. It is a plan of the floor immediately under the ore to be mined, while Fig. 74 is an elevation of the same.

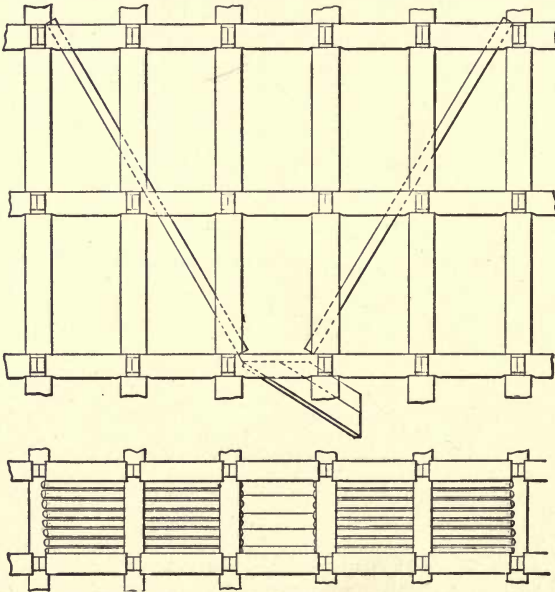

FIGS. 76 AND 77. — CHUTE ARRANGEMENT, OLD IRONSIDES MINE.

A special method of chute building was adopted here. Above the first floor they were built in the shape of a long trough-like

V running from one brace down and across to the next. Poles were used for this work, and spiked securely to the square sets. Figs. 76 and 77 show the arrangement of the chutes in elevation and plan. At convenient intervals an outlet was made, and between the chute gates the ore was allowed to pile up a little. The ore was trammed to the shaft in ordinary one-ton cars, and hoisted to the surface on a cage through a vertical shaft.

It will thus be seen from this brief account that a very easy and economical method of removing the ore was in vogue at the Old Ironsides.

BALTIC MINE, BALTIC, MICH.

The method adopted in the Baltic is peculiar to this mine, and is not used, as far as I am aware, at any other mine in the copper country. It is a simple system of walling up each tramway with waste rock, thereby keeping a roadway open, and filling in above with the gangue and country rock, as convenient. In this way the expense of putting in timber is minimized, which is offset by the walling and filling. The method is only applicable when the vein carries waste, or when waste rock is easily and cheaply obtainable.

The material mined is native copper, which occurs in a vein of lava rock both as "shot copper" of varying size scattered throughout the rock, and as "mass copper," which is solid copper of more or less irregular shape. The pitch of the vein is about 70 to 72 deg., and the width varies from 20 to 50 ft. Parts of the vein are more or less barren of copper, and this rock, called "poor rock," is picked out by the "copper pickers," and forms a good part of the filling.

The vein was opened up by shafts and drifts, and when stoping began, the drifts were widened out to the full width of the vein. After the copper rock was cleaned out from the face, the poor rock was taken back in cars, and shoveled to one side. When the "wallers" had enough rock to start on they began and walled it up on each side of the track, leaving a space of 7 ft. for a tramway. The walls were made about 7 ft. high, and heavy stull timbers laid on them as caps. These caps were placed about 3 ft. apart and covered with cedar lagging, so that no rock could come through. (See Fig. 78.)

At intervals of about 40 ft. spaces were left for chutes on one side of the track. They were built up with rock and had a timber margin for planks to be spiked to. In the bottom of the chute flattened hemlock timbers were laid, and a heavy sheet-iron plate

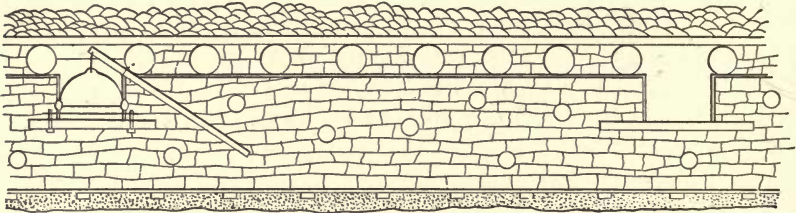

FIG. 78. — METHOD OF WALLING UP, BALTIC MINE.

was fastened to them with drive bolts. The bottom of the chute was made flat because very large boulders were handled in it. For a gate a spout was used, one end of which was raised and lowered by means of a long, stout lever. The copper rock thrown

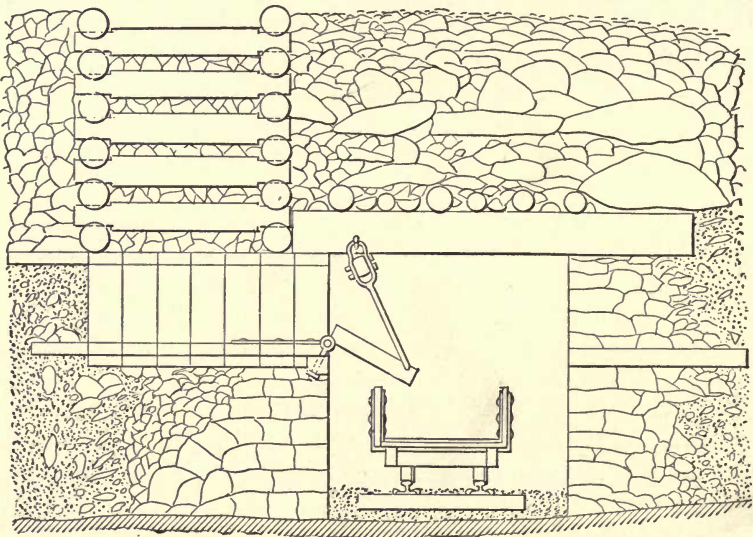

FIG. 79. — METHOD OF WALLING UP, BALTIC MINE.

into the chute was pulled out by the trammers into two-ton cars, taken to the shaft, and dumped directly into the skips.

When the work had progressed far enough on the station level, overhead stoping began above the caps and walls, by

drilling with machines and blasting in the usual manner. The rock broken down was picked over by the copper pickers, the copper rock being thrown into the chutes, and the poor rock thrown back to fill up the excavation. As more and more filling accumulated, the chutes were carried upward in the form of a hole 5 ft. square, by means of heavy cribbing flatted at the ends and spiked. (See Fig. 79.) Sometimes the pickers needed wheelbarrows to get the rock into the chute or "mill."

In stoping, a good breast was carried along, and heavy holes drilled, since no damage could be done by heavy blasts, though it was not advisable to shatter the roof too much. As the room grew in height the back got farther and farther away from the filling. This necessitated the use of long posts for the machines and staging for the miners to work from. The idea, of course, was to work as much as possible from the top of the broken rock, but as there were 100 ft. between levels, and not a very high percentage of poor rock, it became necessary to cut out the foot- or the hanging wall to fill in, and thus reach the back. This should always be done after the copper rock has been picked out, as otherwise much poor rock would be mixed with it. An attempt is made to convey an idea of the stope in Fig. 80.

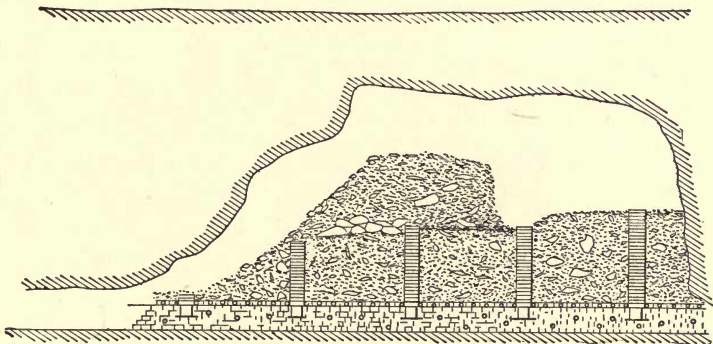

FIG. 80. — LONGITUDINAL SECTION OF STOPE, BALTIC MINE.

This method is supposed to take out practically all the ore, and the only use made of timber is to crib the chutes, and cover the tracks. The vein rock is quite tough, and, with a slight arch in the middle of the roof, there is comparatively little danger from overhead. The greatest difficulty to be encountered will be in making connections between levels. Here the filling from

the level above will run down and mix with the copper rock below. Taken altogether, however, this is an excellent method of mining, and has given the Baltic people satisfaction up to the present time.

ATLANTIC MINE, ATLANTIC, MICH.

The Atlantic vein is similar to the Baltic, though it only averages about 15 ft. in width, and it does not carry so much copper. This rock is not picked over, but the total product

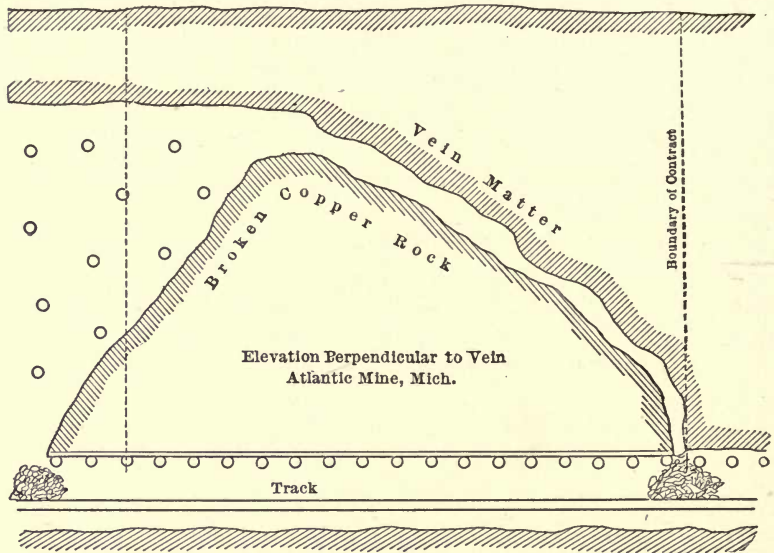

FIG. 81. — STULL TIMBERING, ATLANTIC MINE.

mined goes to the stamp mill. Thus no filling can be obtained from the rock broken and, the vein being narrow, stulls can be used.

When the levels have been opened up the miners take contracts to stope out the pay rock. Each contract includes a part of the vein 99 ft. in length and extending between levels, which are about 85 or 90 ft. apart, and the price is paid on a basis of at least a width of 15 ft. The contractors first run a drift to the end of their ground and commence stoping, taking out enough rock to put in the stulls to protect the level for tramming.

These stulls are very heavy, about 20 ft. or more long, and placed in hitches cut in the walls. They are inclined at an angle

of about 70 deg. to the horizontal, thereby leaving room for a track between the stulls and the hanging walls. (See Fig. 81.) At the same time they were quite steep to prevent them taking up more weight than they could safely bear. They are covered with lagging, which prevents the muck from coming down on the track. When this line of stulls is finished, stoping is commenced higher on the vein. The miners keep rigging up on the rock they break and it is trammed out from below when they are crowded for head room. In this way they are always close to the back, and work to the best advantage. They work up to within 15 ft. of the level above, and then, as the rock is withdrawn, the timbermen place stulls wherever they are needed to support the hanging, and make it safe for the muckers below. The pillars left constitute the floor of each level.

This method furnishes one of the cheapest and best methods of getting out stamp rock in the copper country. The width of the vein, its regularity and pitch or dip, make this a peculiarly valuable method to the Atlantic Company. Without it the mine would probably be operated at a loss, as the copper values do not exceed 25 lb. per ton of rock.

Coming now to the iron country of Michigan we find a somewhat different order of things. Here we do not have the ores in regular well-defined veins, as is the case in the copper country. On the contrary, the ore occurs in blankets or deposits of more or less irregular shape, and the sustaining power of the adjacent rock is a far more uncertain quantity. The ore itself varies a great deal, some being soft and capable of caving, while much is hard, and a caving system could not be adopted. Some again is intermediate between hard and soft ore, and a combination of a caving system with some other method becomes a necessity.

BARNUM MINE, ISHPERING, MICH.

This is a hard ore mine producing a hard hematite. The system of mining is simple and inexpensive, although about one-third of the ore is left for pillars. The levels are from 40 to 50 ft. apart, and after being driven, raises are run up to the level above at convenient intervals. When the raises are completed, the miners begin at the top and mill the ore down the raise in a manner similar to the "glory-hole" method already

described, except that the work is, of course, underground. They work from convenient benches and gradually cut out large chambers. Care must be exercised in scaling any loose rock from the roof while the men are close to it, because when they get lower down the roof will be out of reach. Wherever necessary, pillars are left 22 ft. square, one being as nearly as possible directly above the one below. Machines and tripods are employed, and the rate of drilling is slow, varying from 4 ft. to 15 ft. of hole per shift. The ore is also hard to break, and a 50-per cent. dynamite is used. There are no pockets in the mine, and the cars are hoisted to the surface by a single-compartment shaft. As the method at the Barnum is so simple, little more need be said; suffice it to say that the method is very wasteful of ore, because such a large percentage of it is left in the mine.

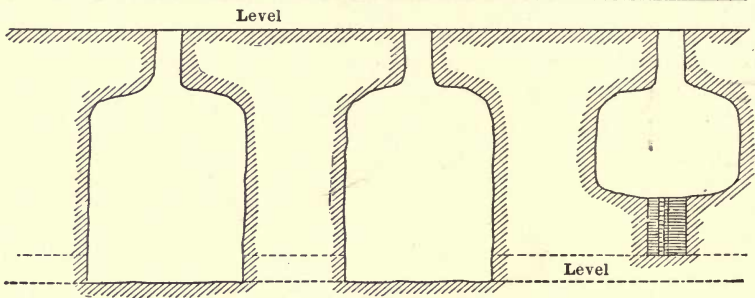

FIG. 82. — STOPES AND PILLARS.

SECTION 16 MINE, ISHPERING, MICH.

The ore from this mine was also fairly hard and a similar method of mining was adopted. Levels were run from the shaft to the orebody at intervals of about 60 ft., and a drift run along the foot- or hanging wall as desired. From this drift raises were driven every 50 ft. to the level above, thus making a passage for timber and ore. At 15 ft. below the upper level the raise was enlarged into a stope or room, and made of such a size that it would be safe to work in, dividing pillars being left on each side. The ore was thus removed down to the level below, and pillars were left extending across the orebody.

When the rooms had all been excavated in this manner the robbing of the pillars began. The pillars were usually 25 ft. through, and they were undercut on one side to a distance of

about 9 ft., and right across the vein. The timbermen then built cribs of timber 8 ft. square in this space, and as many as they had room for, leaving a space of 3 ft. between them for a passage. These cribs were built right up to the back, wedged down and filled with rock. (See Fig. 83.)

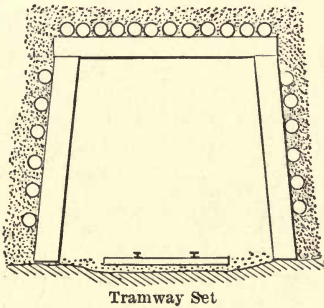
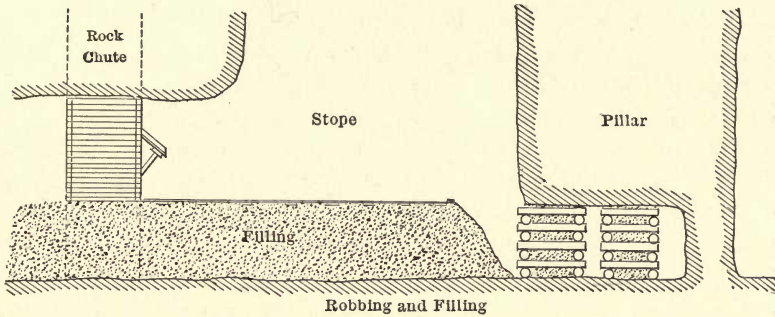

FIG. 83. — FILLING SYSTEM, SECTION 16 MINE.

The next step was to undercut another 9 ft. and treat it with timber cribs and rock in a precisely similar manner. Finally the last portion of the pillar was removed and cribbed, and the pillar rested now entirely on the crib supports. The stopes on either side of the pillar were then filled with loose rock to the level of the top of the cribs, and also in between them, a passageway, of course, being left for tramming.

The pillar having been undercut to a height of about 8 ft., another slice is removed in much the same manner, at a higher level. Mills become a necessity in order to let the ore down through the rock filling, and these are made of round poles and placed at convenient intervals. As the pillar is attacked at a

higher point the work proceeds on the top of the filling, hence by this method it is possible to remove practically all the ore.

The filling used is obtained from two sources: part is furnished by the ordinary development work, and the remainder is obtained from the dump of a neighboring mine. It is loaded into railroad cars, and dumped directly down a raise for that purpose. This raise is tapped where desired by a rough chute, and the rock trammed in small dump cars running on tracks laid on the filling. These tracks are readily moved laterally, so that the rock is conveyed to the place desired without very much shoveling being required.

In parts of the mine where the orebody is of such nature that ore pillars are not necessary, a method of overhand stoping is prosecuted. This operation is followed directly by the filling, the ore being mined out and the excavation filled with waste rock. Where the roof is not good, cribs are built on the filling to support it.

Again, in other parts of the mine, filling is not used, but the ore is mined from each level upwards, and the regular square-set timber erected.

The methods of mining at this mine are therefore somewhat special and varied. The cause of this variation is due to the fact that the orebody changes from place to place in hardness, width, and accessibility. In some parts of the mine it is hard to introduce the filling, while in others it is a cheap and efficient adjunct in extracting the ore. Wherever used it forms a compact and satisfactory substitute for timber, which, to perform the same duty, would be quite expensive.

SOFT ORE HEMATITE MINE, ISHPERING, MICH.

Here we have a mine which was formerly covered by Lake Angeline, a body of water of about 100 acres in extent, and 50 ft. deep in the deepest part. The water was pumped out by means of powerful pumps, and the lake bed became comparatively dry. On the margin of the old lake shafts were sunk, and the mining of the large deposits of soft ore was begun. The ore, being a soft red hematite, was very easy to break down, but it was impossible to have large chambers excavated, because of its

heavy settling nature. As the soft ore caved so readily, a caving system of mining was soon inaugurated.

Haulage ways were, as far as possible, made in solid rock. Then raises were driven to the top of the ore deposit, at intervals of from 60 to 100 ft., and cribbed with two compartments, one for a ladder road and the other for ore. Sub-levels were also made to facilitate operations. The ore was loaded into cars holding about $2\frac{1}{2}$ tons, which were attached to a "bull-dog," and taken to the shaft in trains of six or seven. The bull-dog was

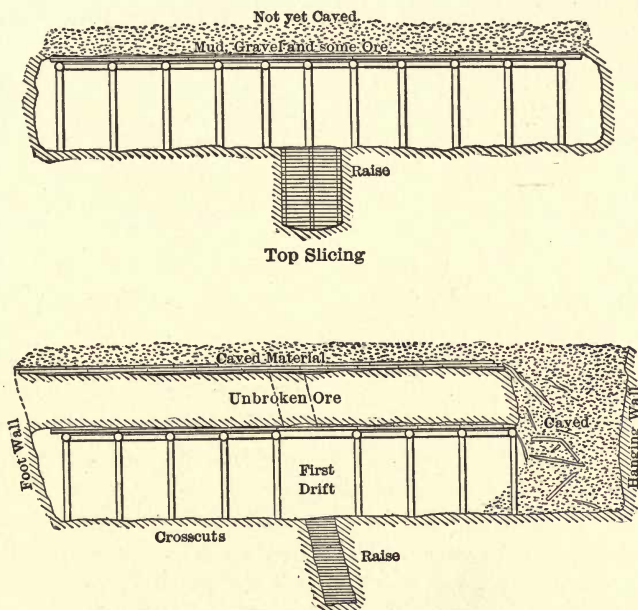

FIG. 84. — CAVING SYSTEM, SOFT ORE HEMATITE MINE.

operated by a cable, each end of which passed around a drum run by compressed air. One engine was located at the shaft and the other at the end of the haulage way. At the shaft the cars dumped directly into the skip, and were moved up to, and away from, the shaft by hand. The idea of the bull-dog is to facilitate coupling, the cars being connected to the bull-dog instead of directly to the cable.

When the chutes were completed a "top-slicing" scheme was begun. A drift 8×8 ft. was driven parallel with the deposit, and timbered with square sets. These sets consisted of legs and caps

as shown in Fig. 84, and were placed 4 ft. apart. At the raise it was important to have rather stout timber, because here the timber was expected to stand the longest, and was therefore subjected to most pressure. Farther from the raise or chute the timber was much smaller, 6 to 12 in., and the caps were covered with light lagging. The caps, as a rule, were a few inches larger in diameter than the legs.

The second step in top-slicing is to begin at the farthest end of the drift and cross-cut to both foot- and hanging walls. These drifts are also 8 x 8 ft. and are driven parallel, and one after another, until the whole area is excavated, that around the chute being taken out last. The same procedure is followed on the opposite side of the chute. The floor is then all lagged over to prevent mud, gravel, etc., from mixing with the ore when subsidence takes place. The legs of the sets are blasted out and the overlying burden is lowered, as a consequence, all over the area in question.

Mining below this is now done by the real caving system. The miners drop down 12 or 15 ft., depending on the hardness of the ore, and run a drift as before. Side rooms are run to foot- and hanging walls, and when these are reached the most remote sets are blasted, and the roof is caved in. By working as they retreat practically all the ore is removed from beneath the lagging above, only one set usually being blasted at a time. Sometimes several rooms are worked out before caving, but it is unsafe to leave them for any length of time. It is deemed advisable to finish one room before beginning another. In this manner a whole slice is taken out, and overlying débris or "gob" is lowered once more. Then a drop is made for another and another slice, until the bottom of the deposit is reached.

Contrary to what might be expected this is a comparatively safe method of mining. The men work near the back all the time, and, should there be any danger, warning is given by the gradual crushing of the timber. No large rooms are excavated at any one time, and there is practically no danger from this source.

The system is also cheap, comparatively little timber is used, and even that is of an inferior order. Very little powder is necessary, and there is not much drilling done. Holes are drilled with machines, augurs, or hammer and drill, as the particular hardness of the ore may make advisable. The cost of mining is low, and

contracts run at \$4.50 for an 8x8-ft. drift per foot of advance. The miners make from \$55 to \$60 per month after deducting all expenses for powder, caps, fuse and candles.

QUEEN MINE, NEGAUNEE, MICH.

In the Queen mine, as its name implies, we have a fine example of systematic iron mining. The orebody is large and fairly regular and lends itself particularly well to methodical development. The ore is not very hard, and it is not soft enough to cave, as in the Hematite. A special method has been adopted and seems to answer the purpose very well. The system in vogue starts out as a square-set system and develops a caving system as the work proceeds.

The orebody is in the shape of a lens, and dips to the north at an angle of 38 deg., and also pitches to the west at 45 deg. Six shafts have been sunk, the first three on the eastern side being now worked out. From the shaft a well laid out system of haulage ways has been driven, special attention being given to prevent interference of cars with timber, and *vice versa*. The timber can be handled on one line of tracks often at right angles to the haulage tunnels. The main ore drift has been double tracked, and an endless cable picks up the loaded cars of ore as desired, and takes them to the shaft. The cable is operated by an engine at the shaft with a special device to keep up uniform tension. The cars are attached to the cable, which is always moving, by hand, and are detached automatically when they reach the shaft. They are dumped into pockets and sent back by the cable on the other track. The expense of operating this haulage system is only $\frac{1}{2}$ cent per ton.

Coming now to the mining system proper, we find a face of 3 sets wide or 25 ft. carried forward, and timbered with good substantial square-set timber. Then parallel to this another similar face is driven, but with a pillar 5 sets, or 40 ft., left between. Cross-cuts are also run, blocking out the pillars into squares. (For elevation and plan of stopes and pillars see Figs. 85 and 86.) At the same time these faces are being worked on the level, another and another slice is stoped out and timbered above. In this way the orebody is honeycombed to the top of the deposit, pillars and rooms alternating throughout the level.

After the ore has been excavated in this manner the work of taking out the pillars and caving begins. A raise 8x8 ft. is now run up through the center of the pillar, and timbered with the usual sets. Thus between the center set and the timber in the rooms outside there is a distance of two sets. The top of the pillar is taken out to the depth of one set, and caps of double length are used to connect the center with the outside sets. This

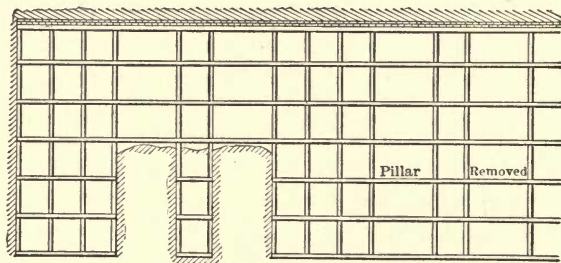

Vertical Section through A-B

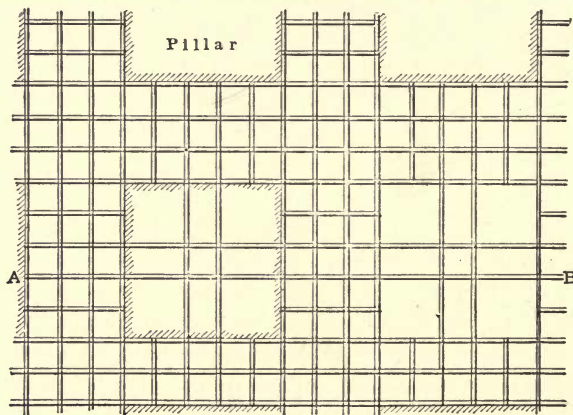

Plan of Stope, Queen Mine.
Negaunee, Mich.

FIGS. 85 AND 86. — STOPES AND PILLARS, QUEEN MINE.

is done on the four sides, and the top heavily lagged. The ore is then worked downward, using the long caps at each step, but without lagging. The material of the pillar is readily broken up and sent down the chutes in the outside sets; in fact, it is the most rapid method of breaking ore in the mine.

When the pillars have all been robbed the tracks are taken

up, a flooring of poles is laid, except where there is a rock floor, and every second leg is blasted out, thus bringing down the whole mass of timbers as well as the roof.

A system called "scramming" is used to mine on the level below. The level is divided into 50-ft. squares, and in each a raise 4x9 ft., in two compartments, is run up to the lagging above, the levels being 85 ft. apart. Starting 9 ft. down, a drift is driven from the raise 25 ft. each way, and timbered with light sets. The ore is shoveled directly into the chute or a wheelbarrow is used. A second drift is run beside the first, though not always, and the bottom is lagged over. Then the legs are blasted, and the overlying débris caved, as in the Hematite mine. The process is repeated until the 2500 sq. ft. is lowered 9 ft. The miners now drop once more, and repeat the operation, and so work down to the level.

While work is progressing in the drift the timbers begin to crack, which is a good sign, because it shows that the mass above is slowly settling. If the timbers do not show that they are supporting great weight the débris has become "hung up," and is liable to come down at any moment. Seeing this the miners either blast it down, or get out of the place. When the timbers show pressure the workmen are safe, as the mingled rock and timbers settle very slowly, an inch or so a day.

This method of scrambling is also used in new workings, under gravel, sand, or loose rock. In that case great pits are formed on the surface immediately above.

In the foregoing description of these several mining methods, little attempt has been made to go into the minute details of the various schemes presented. The systems taken up represent the actual practice, in their most essential features, of underground work in western America, outside of coal mining. Much more might be said in regard to many matters connected with them, such as their comparative expense, the percentage of ore recovered, their suitability to general conditions, etc. To go farther into these matters would make the paper unduly long. No references have been consulted, as I have gathered all the data at first hand.

During the discussion of his paper Mr. Parlee said that in connecting up timber between levels, it was considered good

practice to have sills of the level below, in the same vertical plane with those above, surveyed and laid down accordingly, but in carrying up the sets 100 ft. it was almost impossible to go up straight enough to have post match with post properly. They would come either one side or the other of the vertical plane and be out of plumb perhaps a foot or two. Unless they could meet the upper sets exactly, it did not really matter whether the sills below were surveyed or not, except to get the general direction of the timber. The sills of the upper level were caught up by the cross timbers, reaching two or three sills. Little attempt was made to have posts of lower sets directly under posts of upper sets. Bulkheads were often used and the rock must be blasted out carefully and not too fast.

Mr. Parlee also said that the square-set system was used wherever the ore was too hard to cave without it. It was not the intention in the paper to discuss all the methods used in each mine, but only those especially valuable. Different methods might be used under different conditions.

The chairman remarked that what Mr. Parlee had said about the impracticability of exactly connecting the timbering of adjoining levels held true in all parts of the mining world. The theory was that posts in successive levels should come under one another, and in certain mines that he had visited more or less successful attempts had been made to do this, but in most cases the method described by Mr. Parlee had to be adopted. As he had said, the main thing was to see that the vertical lines were kept true and that the timber was put in substantially. Sometimes comparatively heavy bulkheads were used. It was, of course, possible to survey with sufficient accuracy to have the posts placed perfectly plumb and in line, but this was too troublesome, and it was still more troublesome to erect great masses of sets exactly in line and plumb, especially when, as was frequently the case, there was movement going on in the orebody or hanging wall.

MINE TIMBERING

IN SECTION 16 OF THE LAKE SUPERIOR MINING
COMPANY, MICHIGAN

BY C. ST. G. CAMPBELL

MINE TIMBERING IN SECTION 16 OF THE LAKE SUPERIOR MINING COMPANY, MICHIGAN ¹

BY C. ST. G. CAMPBELL

IN the following paper it will be necessary to depart somewhat from the subject proper and give a brief description of the location of the mine, the method of mining the ore, the management, etc.

Section 16 is essentially a hard ore iron mine, situated three-quarters of a mile from Ishpeming, a town fifteen miles from Marquette, on the south shore of Lake Superior.

The mine is worked chiefly for hard ore, there being three large lenses, each of a different grade, according to the percentages of iron and phosphorus contained. There are also two "pockets" of soft ore, which is locally known as "hematite," but after mining these pockets for some time, it was found that the ore was too high in phosphorus to compete with the soft ores of the surrounding mines. So, for the present, at least, the mining of it has ceased.

The hard ore is found with a foot-wall of decomposed diorite, resembling soapstone, and a hanging wall of quartzite or jasper. A great dike of diorite cuts across the deposit and makes the formation somewhat irregular. The three lenses dip at an average of 70 deg. with the horizontal. They have an east to west strike and vary very much in their dimensions, ranging from 10 to 700 ft. long. The dimensions of the so-called "south vein" have not yet been determined, as it reaches below present operations.

The method of extracting this hard ore is as follows: At intervals of 60 ft., levels are run out from the vertical or hoisting shaft until the ore is reached. A tunnel is cut along the length of the lens, clinging to either hanging wall or foot-wall as the

¹ From *Transactions of Canadian Society of Civil Engineers*, Vol. 18, 1903.

case may be. Raises are then made every 50 ft. to the above level, or nearly so, a back of 15 ft. being left to make tramping safe. Through this back a small hole is cut to let down timber, also for the purposes of ventilation, etc. When first cut, these raises are 9 ft. in diameter and are afterwards widened until the dividing pillar is as thin as is consistent with safety, say 15 ft. in the average.

The next step is, in many ways, modified by the width of the lens, but it suffices to say that the stope is carried across the

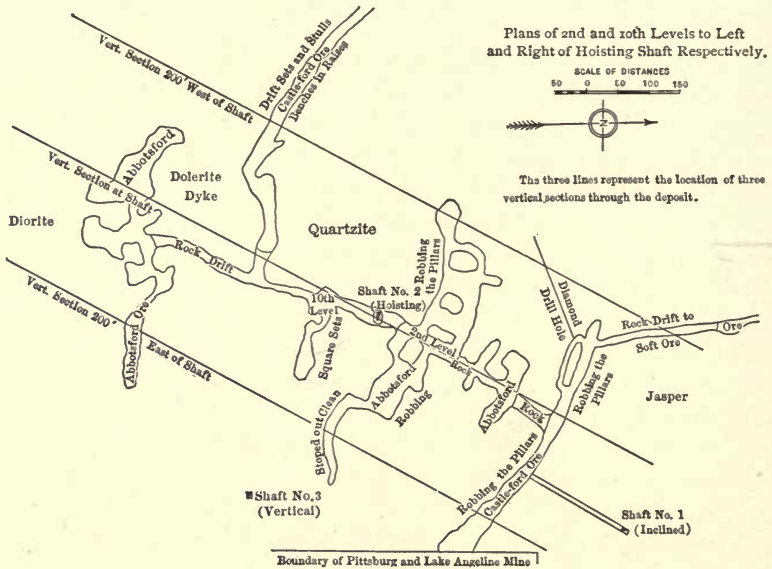

FIG. 87. — SECTION 16 MINE.

Projection of 2d and 10th levels. The levels are 370 ft. apart.

width of the vein, the shift boss using his own discretion as to the method employed. Finally, however, the stopes or raises are filled up with rock, leaving a timber tunnel for the passage of trams on the level below. Mills are also built and rock filled in around them, a process which will be described more fully later. The pillars are then mined out and their places filled in with rock. In this way all the ore is secured.

The hematite, so called, is mined by the "square-set" system, which consists of taking out slice after slice of the ore, the length and breadth of the pocket, and in its place putting timber in the

form of skeleton cubes, the sides of which measure 8 ft. These cubes or square sets, as they are called, are put in one at a time, just enough ore being taken out to allow the erection of a single square set. The pocket is worked from bottom upward, thus securing the advantage of gravity for the removal of the ore. All the ore is sent down by means of improvised chutes made of lagging.

The mine is at present 850 ft. deep and the shaft is still being sunk to tap the south vein. There are at present 13 levels, 12 of which open on to the shaft. The 4th, 5th, 6th, 7th and 8th levels have all been mined out even to the pillars. On the lower levels, tunneling and raising are being carried on, while on the first three levels the "robbing of the pillars" is not yet completed.

There are two other shafts, besides the one above mentioned. These are used for ventilation and shooting down the rock used for filling. These shafts, one of which is inclined, reach only to the second level. From there on, the rock is sent to the lower levels by means of mills.

For the most part, the "hard ore" justifies its name and is hard and compact, but occasionally it is of a slaty structure or full of cracks and fissures. In such places it is necessary to use drift sets. Similar protection is also necessary when drifting through decomposed diorite, locally known as "soapstone."

The proposition which the timberman has to handle now having been outlined, the respective applications of the different methods will be taken up in detail.

The timber is obtained, for the most part, from lumber camps, the farthest not being more than 20 miles from the mine. This timber is taken to the mine by rail and stocked near the main shaft. Second-class logs are used, knots and slight crookedness not being objectionable. The logs, cut into either 5½-, 8-, 10- or 16-ft. lengths, are lowered into the mine by means of chains attached to the bottom of the skip. The timbermen land them at the level station below with the aid of a rope, ship them on to a tram and take them to a timber-dock, where they remain until required. Between the hours of twelve and one on the day shift the miners are on the surface for lunch, and advantage is taken of this fact to lower timber. In consequence the timbermen remain below and take out timber, thus postponing their

lunch for one hour. Hemlock and white pine are used for the most part in the large timbering. Cedar is used for lagging. The captain is at present experimenting on hard wood. Squared timber is used only in the shaft and under certain special conditions elsewhere. In other places not only is timber used round, but also with the bark on. The life of a "stick" is very uncertain, depending upon the nature of the wood, the stress to which it is subjected, and the temperature, hence the moisture. On the 7th and 8th levels, immediately above the pumps, which are on the 9th level, the timber lasts only five months, after which it is quite easy to force the point of a candlestick six inches into the wood with the hand. This is exceptional, however. The average life of timber in the mine is *said* to be ten years. The timber is often crushed by the settling of ground, but there is little danger to life in this, owing to the slowness of settling.

SHAFT TIMBERING

The method of sinking the hoisting shaft is somewhat similar to that of raising a square set. A rectangular hole is stoped down to a depth of 10 ft., having a width of 10 ft. and a length of 18 ft., and in this hole is set up a double square set, 8x8x16 ft. This square set is suspended from the one above by means of bolts. It is then wedged into place and lagged between the timber and rock. The shaft is then sunk another 8 ft. and another double square set placed and bolted to the bottom of the former, and so the sinking and timbering proceeds. The timber in the square sets used is from 12 to 18 in. in diameter. Every time an advance of three sets (24 ft.) is made, the small shaft pump is lowered the same distance, so keeping within the 27-ft. practical pumping limit.

The shaft is then lined inside the square sets with 8x8-in. squared timbers, 18 ft. long, placed close to one another vertically, giving the shaft a box-like character. In each set and parallel to the ends of the shaft are placed cross pieces to which planks are nailed, thus dividing the shaft into four compartments. The center two are about twice the size of the end ones and are used for skip roads, while the end compartments are used for pipe, pumps and ladder ways. (See Fig. 88.)

The skips, which are steel boxes 2 ft. 6 in. square and 5 ft.

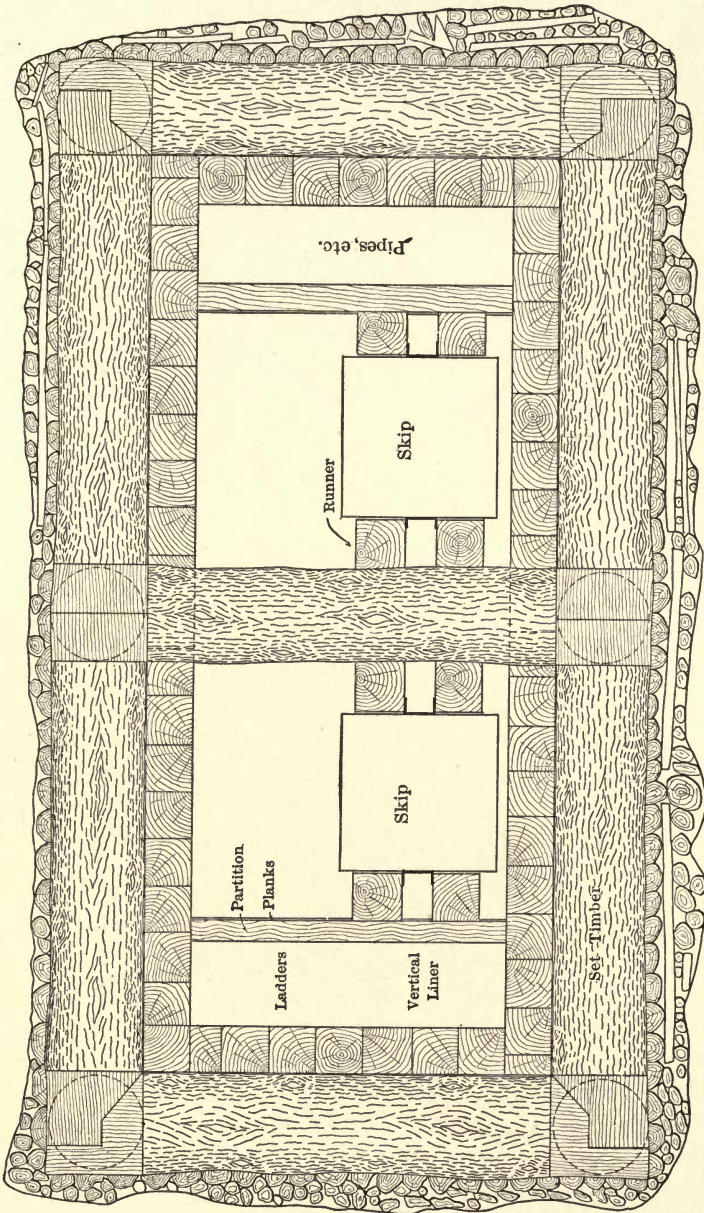

FIG. 88. — HORIZONTAL SECTION THROUGH SHAFT, SECTION 16 MINE.

high, slide in runners which consist of four 8x8-in. beams, two at each side of the skip. These are placed vertically 6 in. apart.

Until lately much trouble has been experienced from water in the shaft. With a view to stopping this water downpour, troughs or garlands have been arranged to carry the water into pumps at depths of 190 and 680 ft. This has proved very effective.

The rock shafts are very much simpler in construction, being merely lined with rough unbarked logs built up like a crib. It is usual to hoist to the surface all rock from the stopes at the bottom of the mine and send it down again to the levels where the pillars are being robbed. Obviously this supply of rock would be insufficient. Hence carloads of loose rock are brought from the No. 1 hard ore mine and dumped down one or other of the shafts as required.

DRIFT SETS

In running through soapstone on the 2d, 9th and lower levels, the back and sides of the tunnel are so weak that they

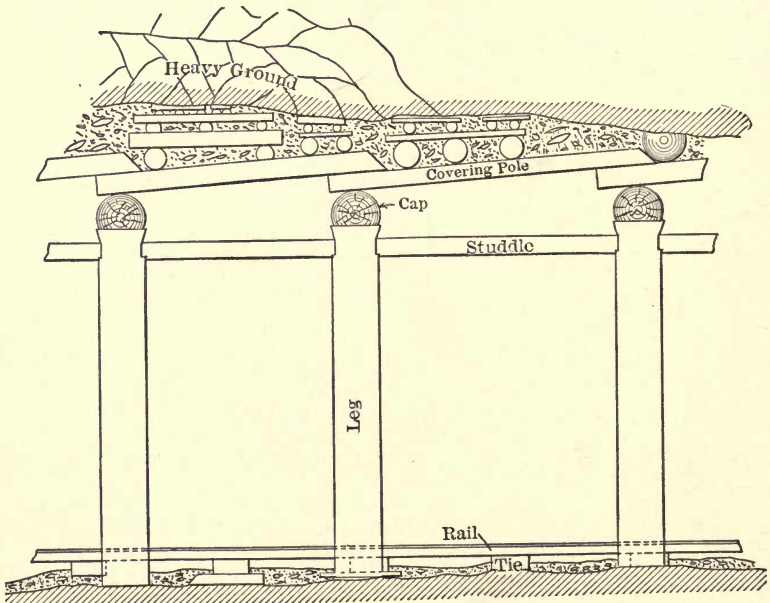

FIG. 89. — SIDE ELEVATION OF DRIFT SET, SECTION 16 MINE.

have to be supported. This is done by means of "drift sets." Two trestles, 5 ft. apart, each consisting of two legs and a cap,

with a covering of poles resting on the caps, constitute for the main part what is known as the "drift set." The caps are chopped flat at the ends so as to set firmly on the legs. The pairs of legs are kept apart by studdles, which are poles 4 ft. 6 in. long and 4 in. in diameter, set close under the caps and at right angles to them. (See Fig. 89.) The legs are firmly spragged against the wall, and spaces between the legs lagged on the rock side. The lagging is nailed to the legs horizontally, one above the other, and the loose rock is piled in behind the partition so formed. The covering poles used are from 4 to 5 in. in diameter. These are laid lengthways, the ends of the poles in one direction of a set resting on a cap, and in the other direction resting on the ends of the poles of the preceding set. By means of small pieces of timber the back is caught up and wedged tightly. (See Fig. 90.) If the pressure is likely to be great, owing to caving in

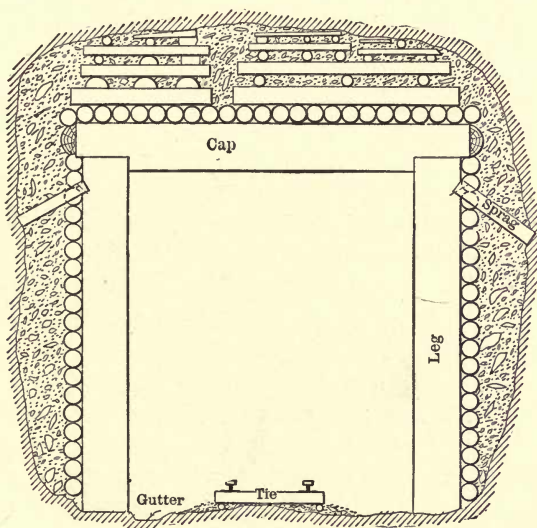

FIG. 90. — END VIEW OF DRIFT SET, SECTION 16 MINE.

of the sides of the tunnel, the legs are set wider apart at the bottom to ensure greater stability. At each end of a line of drift sets slanting props or "rakers" are propped against the legs to keep the whole steady when the blasts go off. (See Fig. 91.)

A single square set consists of four vertical legs arranged in an 8-ft. square, each leg being 8 ft. high. The legs of two opposite sides of this square set are held together by caps, which rest on

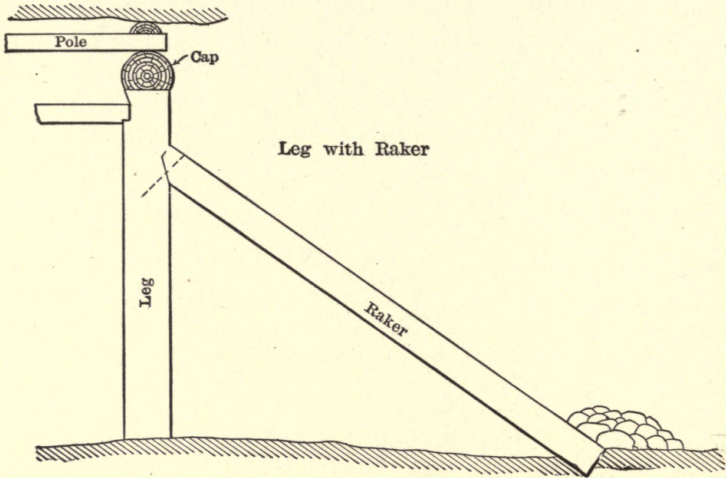

FIG. 91. — RAKER, SECTION 16 MINE.

SQUARE SETS

the top of the former. The two other sides are held together, or, better still, held apart, by studdles, in this case 8 to 10 in. in diameter. The studdles are nailed in place a little lower than the cap. The legs and caps have average diameters of 18 and 12 in. respectively. The top of each set is covered with 4-in. poles, in order to prevent ore from coming down on top of the miners. The whole set is spragged securely when first built and thus remains until surrounded with other sets. For the sake of strength and continuity, the same two sides of a square set always have the caps. If the stope is fairly wide and high, chutes are built in so that each one is fed by five columns of sets. Twice attempts have been made to mine the hard ore by this system, but without success.

STULLS

In raising up along the lens the hanging wall is often loose, great masses sometimes breaking off, and, in consequence, it is necessary to prop the loose ground up by means of stulls. (See

Fig. 92.) A stull is a single stick of timber varying in size according to the stress to which it is subjected. The distance is

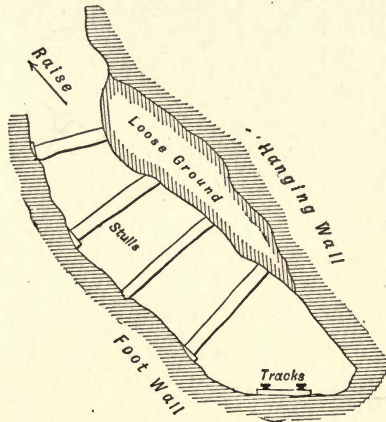

FIG. 92. — STULLS, SECTION 16 MINE.

measured from foot-wall to hanging wall and the stull cut a corresponding length. A socket is made for the end of the stull on the foot-wall by scooping out a shallow hole. The stull is then driven into place and fixed tightly by means of wedges. For obvious reasons, every endeavor is made to have the greatest stress along the line of the prop, though in some cases this is not at all possible. (See Fig. 93.)

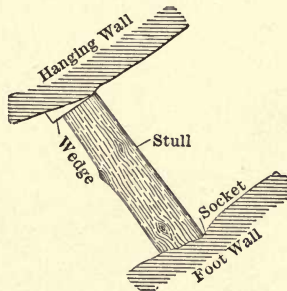

FIG. 93. — STULL, SECTION 16 MINE.

In the raises on the 13th level, it is impossible to set up machines, owing to the narrowness of the lens and the steepness of the dip, except as follows: Two stulls are erected within 7 ft. of the breast on either side of the raise (8 ft. apart). On the top side, poles are laid halfway up to the hanging and then ore is pulled down behind these poles until a horizontal surface is

obtained. On this surface, which is about 6 ft. wide by 9 ft. long, the machine is set up. (See Fig. 94.) This is called a bench, and is used for 16 ft. of advance stoping, after which another one is built above it in the same manner. It is found expedient to remove the lower ones as soon as the top ones are built, to give free passage for ore.

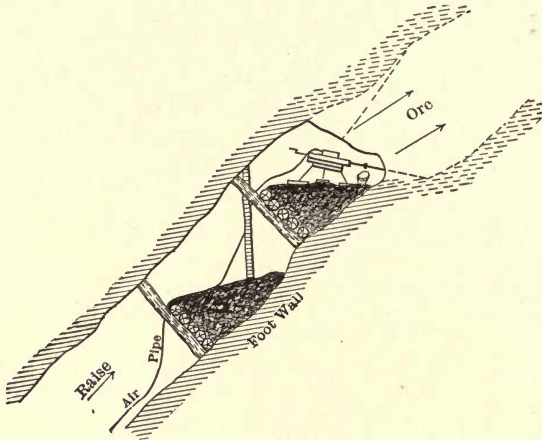

FIG. 94. — METHOD OF SETTING UP MACHINES.

Great difficulty is experienced in getting timber up into the raises. Owing to oversight, all the tackles are too short, so the logs have to be carried up the slope by the timbermen, who hold the log under one arm and use the other to pull themselves up. It is quite customary to do this for 30 ft. before the tackle comes into play.

TIMBER PILLARS, OR CRIBS

The duty of a timber pillar is to hold up ground. It serves the same purpose as a vertical stull, only on a much larger scale. The pillar is made of rough unbarked logs, 8 ft. in length and anything from 6 in. to 2 ft. in diameter, according to the weight the pillar is to bear.

A pair of such logs, 7 ft. apart parallel to each other, are laid directly under the "bad ground," and on top of these are laid two more at right angles to the first two, the same distance apart and parallel to each other. Again on top of these are laid two more in the same way. The pillar is thus gradually built up to the back and eventually wedged down tightly by lagging and

small pieces of wood. Considerable experience is required to make a tight fit, owing to the unevenness of the ground and the tendency for the whole to shift. All the pillars are inspected every day by the timber boss to guard against any such failure. In laying one cross piece on top of another there is great tendency to roll; in consequence, notches or "joggles," as they are called, are cut in the lower log, into which the upper one fits. It is not usual to cut them more than 3 in. deep.

Wooden pillars are used nearly altogether in the robbing of the ore pillars in between the stopes. These ore pillars are about 25 ft. through from stope to stope. A space is cut out of the pillar, about 9 ft. through and the width of the lens, if the same be narrow, and 8 ft. high. As many pillars as can be are built in this space, 3 ft. always being left between them for walking roads. Sometimes, instead of making two pillars of the foregoing dimensions, one long pillar is made 16x8 ft. The inside of the timber pillar is now filled with loose rock. This rock steadies the pillar and takes the bulk of the weight when the back settles. The long pieces are called "edgers" and the shorter ones "cross pieces." When these pillars are securely wedged against the back, the machines are set to work again and a space similar to the first is mined out and treated with pillars. This process is carried on the width of the vein and breadth of the ore pillar until all the ore in the latter rests on timber. The stopes on either side are now filled with loose rock to the level of the top of the timber pillars, likewise the spaces in between the pillars, and the process of mining out and timbering proceeds as before, the timber pillars having as their floor the tops of pillars of the slice below. The level of the rock in the stopes is kept up to the bottom of the timber pillars.

Docks

The purpose of a "dock" is to hold back rock. It is used where loose rock is pouring down upon the track and so stopping the trams; likewise in filling the stopes, as before mentioned.

The dock is a simple cribwork like the timber pillar. Rock is dumped inside and then the running rock is allowed to bank up against it. The double length 16 ft. is more usual than the single in docks. To save timber and labor the inside edgers are

sometimes done away with, the ends of the cross pieces resting on the outer edger and on the sloping pile of rock. As the work progresses, a couple of men shovel down rock and thus keep the level of the rock up to the required height for the cross pieces to rest upon. (See Fig. 95.)

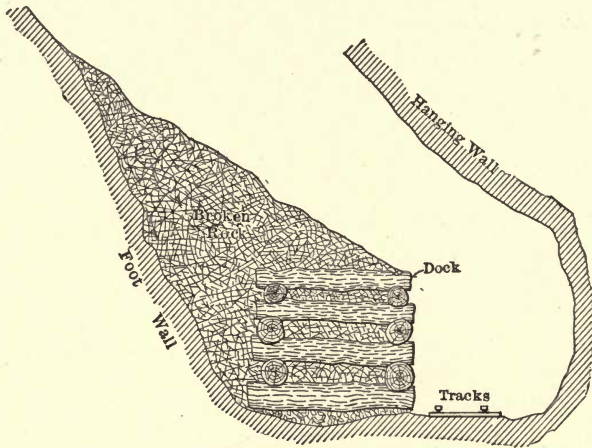

FIG. 95. — DOCKS.

In filling the stope a tunnel must be left for the trams, hence on both sides of the track docks are built to a height of 8 ft. and are filled with rock in and behind. A double layer of covering poles, 4 in. in diameter, is laid across from one dock to the other and the whole is filled over with rock. It is considered advisable to leave ample space overhead in the tunnel, because the pillars sink sometimes 3 ft. or more, owing to the settling of the rock filling. It is found that the hanging wall side settles much faster than the foot-wall side.

The spaces between the logs are stopped up with "filling pieces," to prevent the rock from coming out into the tunnel.

Mills are used in robbing the pillars, to convey to the level below the ore which is mined. A mill might be called the converse of a timber pillar. It is cribwork built up like the other, but is not filled with rock. Instead, the mill is covered with cedar lagging on the outside and filled around with rock.

The mill is built in the same relative position to the tunnel as the dock. As the ore is taken out above, it is dumped into the

mill, coming out into a tram in the tunnel by means of a chute.

The mills are made either single or double, being 5 ft. 4 in. by 5 ft. 4 in., or 5 ft. 4 in. by 10 ft. The latter is the more usual form, one compartment being used for a ladder road, the other to dump rock down.

Filling pieces are used in the partition of the double mill to prevent rock from coming into the ladder-road. (See Fig. 96.) There is an enormous wear and tear on the mills, due to the falling ore, hence the soundest timber is used. Hemlock is preferred, owing to its toughness.



The life of a mill is very uncertain. On an average, a mill lasts three months when it is worked night and day for six days each week. What then happens is that the pieces of ore cut through the cribbing pieces, attacking all sides of the mill impartially. To repair a mill, it is lined with $\frac{1}{4}$ -in. 4 ft. x 6 = in. iron plates for 20 ft. down and then with 3-in. planks.

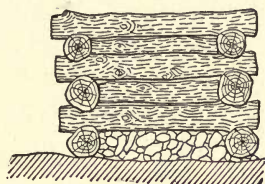

FIG. 96. — MILLS.

The wear and tear depends upon the height of the mill, the kind of timber and the nature of the ore. The diameter of the pieces of timber is from 10 to 18 in.

It is customary to give an inclination of 15 deg. to the vertical in the mill, in order to break the fall of the ore and so save the bottom boards of the chute, and, incidentally, insure safety for trammers.

CHUTES

The chutes that empty the mills are 2 ft. wide at the smaller end, widening out to 4 ft. and covering all the floor space of the mill. They have an inclination of 45 deg., the mouth is 4 ft. 6 in. from the track and protrudes 1 ft. into the tunnel. All chutes are made of 3x8-in. planks. Spaces are cut out of the cribbing pieces of the mill to permit the chutes to be made. Chunks of ore, 8 in. or less in diameter, can get through the chute; anything larger than this sticks and has to be "block-holed." This is to be avoided, because the blasting soon destroys both mill and chute. (See Fig. 97.) In the case of the square chute, the ore

is never allowed to fall directly into the chute from any height over 8 ft., as will be seen, the inclined lagging in each set acting as a sort of chute.

The ore is kept back by means of boards fitting into slits in the sides of the chute. Sometimes it is hard to send these planks into place and so complications arise.



FIG. 97. — A TYPICAL MILL CHUTE.

Notice the extra cross piece for the double mill; also the pike and tram bar beside the track.

STAGING

When it is necessary to take ore off the back of a high stope, the drilling machine has to be raised within a few feet of the place to be mined. This is done by means of staging. A stage consists of three ladders, each at the apex of an equilateral triangle of 5-ft. side. The ladders are inclined outward and are wedged against the back. Planks are then placed on the rungs of the ladders, so as to make a platform. The machine is then set up on this platform. At the best it is a very shaky affair and cannot be carried to any great height, 15 ft. being considered a very good height for the platform of such a stage.

LADDERS AND SOLLARS

In this mine the ladders all have an inclination. This inclination tends to make climbing much easier and safer. The poles of the ladders are made of 3x5-in. white oak scantling. The rungs or "staves" are either of white oak or iron, the former being 1½ in. in diameter, the latter ¾ in. in diameter. Under the calked boots of the miners they are soon worn through and are in many cases left too long for safety.

The shaft ladders are in sections of 20 ft. The sollars are 15 ft. apart, with a hole in each large enough for a man to get through with ease. The end of the ladder protrudes through the hole.

The ladders in other parts of the mine, in the other raises, for instance, are much longer, and are made by bolting together two or more 20-ft. lengths with scantling, on the outside. The ladders are always spragged securely to prevent shaking.

The sollars are a great means of safety and prevent many serious accidents, especially in the shaft, where it is now impossible to fall more than 20 ft., in the ladder road, that is to say.

MISCELLANEOUS

The timber-gang in full force is eleven strong, counting the boss. Below is a classification of the men in the mine.

Captain	\$4.50 per diem. (?)
Shift-bosses	} \$2.50 per diem.
Timber-bosses	
Barn boss	\$2.30 per diem.
Timbermen.....	\$1.85 to \$2.00 per diem.
Miners	\$2.10 per diem.
Helpers to miners	\$1.85 per diem.
Contract shaftmen	(Paid per foot of shaft sunk.)
Ore trimmers	} \$1.85 per diem.
Rock trimmers	
Pumpmen.....	} Amount of wages not ascertained.
Track-layers.....	
Skip tender	
Track cleaner.....	

The tools of the timber-gang are few. The following is a list of their whole outfit:

- Wax candles5 per day of 10 hours.
- Two saws.....hand and cross-cut.
- Axesone per man (used also as hammers).

Spikes various sizes (1-12 in. long).
Ropes various sizes.
Chain 8 ft. long.
Timber truck.
Log pike.

The foregoing information was obtained at Section 16 mine last summer. The figures given are, to the best of my knowledge, accurate. However, the character of the mine is such that rules of thumb are few and far between. When a problem presents itself, it is solved according to the ideas of the particular shift-boss in charge, subject to the approval of the captain, who makes his rounds every morning.

OTHER CONTRIBUTIONS

THE FRAMING OF RECTANGULAR SHAFT SETS

BY WILBUR E. SANDERS

SQUARE-SET PRACTICE AT BINGHAM, UTAH

BY LOUIS S. CATES

SQUARE-SET TIMBERING AT BINGHAM, UTAH

BY CLAUDE T. RICE

MINE TIMBERING AT LAKE SUPERIOR

BY W. R. CRANE

TIMBER AND TIMBERING IN THE COEUR D'ALENE

BY J. H. BATCHELLER

TIMBERING AT THE CHILLAGOE MINES, QUEENSLAND

BY T. J. GREENWAY

TIMBERING IN TASMANIA

BY MARK IRELAND

THE FRAMING OF RECTANGULAR SHAFT SETS ¹

BY WILBUR E. SANDERS

THE support most frequently employed for preserving the integrity of vertical and inclined shafts consists of a rectangular frame of timber, the parts of which, proportioned to any required dimensions, are so fitted together at the joints as to form a connection that will weaken the timbers forming the "set" or frame in the least possible degree. Many methods of framing the joints have been employed and many forms of joints used, but those described below are now almost universally accepted as affording the greatest possible strength while being at the same time of comparatively simple construction. Their present general use may be said to represent a survival of the fittest. (See Fig. 98.)

The connecting joints between the different timbers that are assembled to form the shaft set are made up of various shapes of the tenon and mortise, the gain and the miter, used either singly or in combination, which are the basis of all joint framing, however much they may vary from their simple forms when employed as shoulders, squared or beveled; and all other contrivances whatsoever for bringing together from two or more directions the parts of the set and properly connecting them at such points. In general it may be assumed that the pressure thrust is directed from without inward toward the center of the shaft, and it is for the purpose of opposing or resisting this pressure that the shaft set is designed. This hypothesis, however, is true only in part; for through causes that are sometimes known, but often are unknown, the action of this inward pressure becomes deflected from a normal direction to one that bears upon the frame at a divergent angle, and this is especially true with regard to inclined shafts in certain formations. In such cases the remedy is usually applied whenever it may be necessary, subsequent to the timbering of the shaft.

¹ From *Engineering and Mining Journal*, March 10, 1904, Vol. 77.

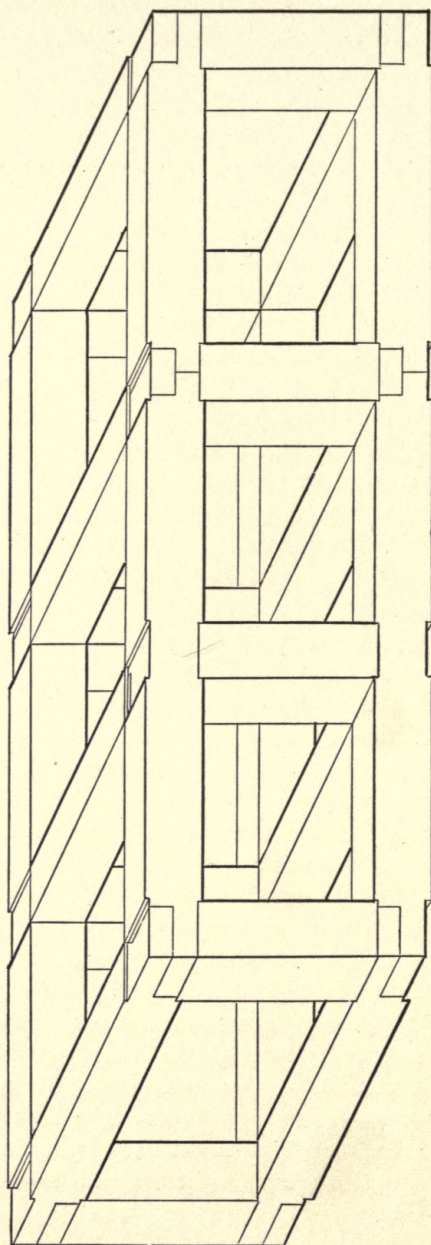

FIG. 98. — FRAME OF RECTANGULAR SHAFT SET, ASSEMBLED.

The several parts of shaft sets are named with regard to their position relative to the shaft. Primarily the frame consists of the timbers of the rectangular set proper, together with those distance pieces, called "posts," which retain it in position at a required distance from the adjacent sets above and below. The rectangular set of the frame is made up of jointed timbers that are known as "plates." While all of the plates of a set are properly wall plates, yet there is a distinction usually made in that the longer pair, those paralleling the greater axis of the shaft, are named "wall plates" in contradistinction to the shorter pair which are in line with, or parallel to, the shorter axis of the shaft, and which are known as "end plates," or briefly "ends." This designation is now generally applied to the plates of both the vertical and inclined shafts, although it is probable that the name originated in connection with the timbering of the latter, in which the longer timbers of the set, the one supporting the hanging wall and that supporting the foot-wall of the working, naturally were called wall plates, and this significance of the term was finally extended to comprehend the similar longer plates of vertical shafts as well.

The above are parts belonging to the simple rectangular set of the single or one-compartment shaft, but the cross-sectional area of larger shafts is usually divided, for purposes of traffic, ventilation, and the accommodation of mining appliances, into two or more compartments separated from one another by divisional girts or "centers." In sinking through firm ground the bottom of the shaft is frequently excavated for a considerable distance ahead of, or below, the timber supports, in order that ample space may be afforded for the placing of the shaft sets, and to remove the timbers thereof from any possibility of being shattered or displaced by heavy blasts beneath. This allows the use of undivided full-length wall plates. In some ground, however, this is not permissible, and the material surrounding the shaft, through which it is being driven, may be of such texture as will make it imperative that the timbering shall closely follow, if indeed it does not crowd, the excavation of the working. Under such conditions the use of full-length wall plates is impossible, and therefore it is necessary to divide or "splice" such timbers that they may be brought into position. The girts act as distance pieces between the plates in order to preserve the width of the

shaft. At the points of division of the wall plates, at the splices, the girts are known as "splice centers," while those used to separate the compartments, at such other points of the wall plates as are not spliced but solid, receive the simple designation of "centers."

Such being briefly a description of the different parts that are assembled together to form the rectangular shaft set, I will proceed to discuss the methods whereby the timbers are cut and framed in order that they may properly and truly join together and fit exactly at the joints. (See Fig. 99.) I will assume that they are of the desired length, and that they are square-sawed to the required cross-sectional area; but in the latter instance they are certain to vary slightly from the exact dimensions and often may be more or less twisted. One side or face, therefore, is selected — the most perfect and even one — if there should be marked imperfections, and this face is taken as a basis of operations.

It is necessary in the first place that this face shall be true, that is, without bend or twist as regards both its length and its breadth. Care in this particular is essential, as it determines the exactness with which the timber shall fit its companion pieces at their common joints in the assembled set; and therefore, upon a perfect plane throughout, or by means of it, depends in large measure the perfection of the set itself. Where extreme precision is required, the selected face is worked to straight-edges, sighting from one to another until at proper points the face has been worked to line with the assumed plane which is shown when the edges of the straight-edges are brought to coincide; bends and twists are removed locally wherever it may be necessary to frame a joint. In the process of framing many prefer to select for this face the one that will be the top or uppermost side of the timber when in its place in the set, and to take all lines, measurements and angles with regard to it; but for sufficient reasons I believe that the basis of all framing should preferably be that which will become the interior face of the piece when the parts shall have been assembled.

Upon this face a center or base line is marked from end to end, either by means of a straight-edge or the chalked line, and all measurements lengthwise along the timber are laid off with reference to this line, as also are those crosswise lines which

locate and outline the shapes of the joints to be framed upon the selected face, the relative positions thereof having been established by the measurements. This base line represents a line at which, should a second imaginary plane be passed lengthwise through the center of the timber at right angles to the

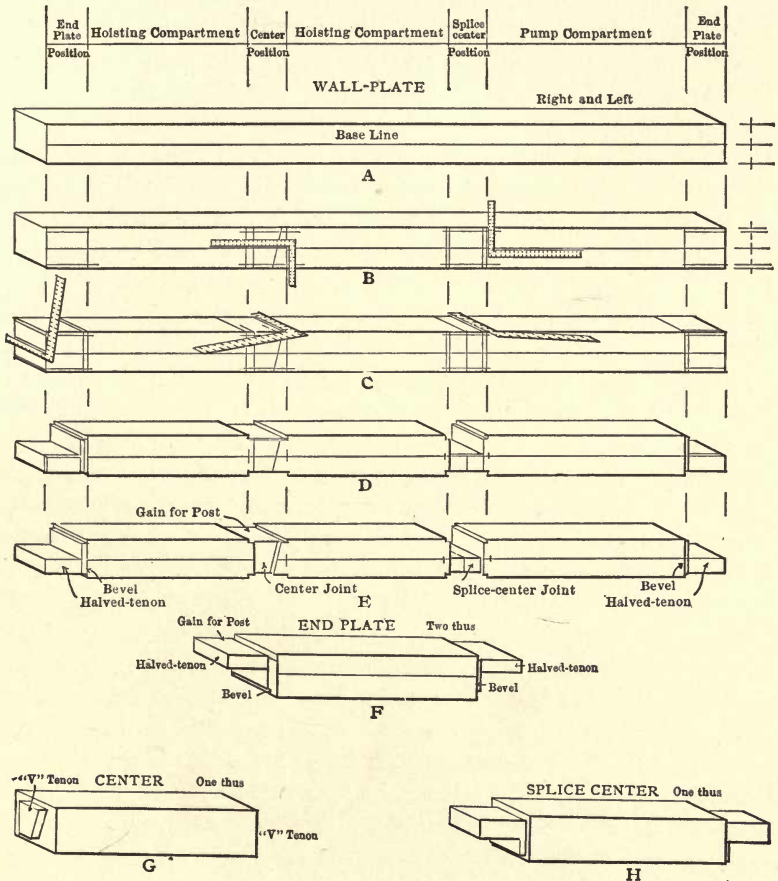

FIG. 99. — LAYING OUT AND FRAMING RECTANGULAR SHAFT SET.

plane of the selected face, it would cut or coincide with the latter throughout its length; and this line of coincidence of the two planes we have fixed upon the face of the timber by marking, so that we may employ it as a basis for the laying out and framing of the joints. (Fig. 99, A and B.)

Backward from this face to required distances there are laid off tenons, mortises, gains and miters that go to make up the joints which will allow the different parts of the set to be brought together into one complete and perfectly connected whole. (Fig. 99 C.) By thus taking all measurements from the base line toward the top or bottom part of the timber, and by projecting the points and lines thus established backward from its selected inner face towards its outer face or back, all troubles due to twists or variations in the size or shape of the pieces going to make up a properly framed set may be overcome; and the joints thus framed will be in their correct relative positions, exact in size and shape, and they will join accurately with those of the other connecting parts of the set. It is needless to say that exactness in the fitting together of the joints cannot be expected unless all necessary precision has been employed in their framing.

The joints that must be framed in the construction of a set are: those at the corners of a shaft, which connect the wall plates and the end plates at their ends; those connecting the centers and splice centers with the wall plates at the division of the compartments; and, where it is required or used, the "boxing" of the ends of the posts into the frame in order to insure that they shall retain their proper positions. The framing of the wall plates and the methods of cutting their joints are shown in Fig. 99 D and E; that of the end plates, Fig. 99 F; of the centers, Fig. 99 G; and that for the splice center in Fig. 99 H.

The wall plates and end plates are joined together at right angles to each other by a combination of the tenon and miter, or "bevel," as the latter is usually designated. The thickness of the tenon is just half that of the plate, the measurements therefor being taken from the center or base line on which is formed one face of the tenons, their lengths being equal to the widths of the mating tenons of the joints. The wall plates invariably have their tenons at the bottom half of the pieces that they may support the end plates while the set is being placed in position in the shaft, the tenons of the end plates on the contrary being framed at the upper half of the ends in order that they may rest upon and be supported by those of the wall plates when the parts are assembled. This halving the timbers in framing tenon for the purpose of support removes just one-half of their cross-section and thereby weakens the pieces at such points proportionally.

This difficulty is overcome by the use of a half right-angled miter, of 45 deg., which is framed from the face of the timber backward usually to a depth of one inch; or, in other words, the piece is so beveled that this mitered face will coincide with and abut against a similar miter that is framed upon the companion piece, both being placed in the same relative position within the joint. By means of this construction of the corner joints of a shaft set it is brought about that the full cross-section of one plate engages the full cross-section of its companion plate at their common end, at which point the two pieces are at right angles to each other, and thereby it is assured that the full strength of one of the timbers supports and is supported by the full strength of the other.

In the case of the simple divisional girts or centers, instead of tenoning through the width of the wall plates at the joints, as do the ends and splice centers, they are connected therewith by a short V-shaped tenon that is mortised into a corresponding gain framed into the inner face of the wall plates at desired points, the tenon being narrower at the bottom than at the top in order that it may not fall or be forced out of its position. (Fig. 99 G.) The shoulders of this tenon should be constructed of a width sufficient to engage the face of the plate, whereby it may afford support to the full size of that timber. The simple center with some form of the V-tenon is employed for the purpose of dividing the cross-sectional area of a shaft into compartments, save only at points where the wall plates are spliced in order to shorten them so that they may be brought to position in confined quarters.

Whenever it becomes necessary to shorten the wall plates, the timbers are so cut that the splice will coincide with the lengthwise center line of one of the cross girts or centers that divide the shaft into one or more compartments. Generally, in the three-compartment shaft, which has been taken as a type for the reason that the framing of all of the different joints employed in shaft sets may be shown in simple detail, this cutting in two or splicing of the wall plates is made to center between the pump compartment and one of the hoisting compartments. The upper halves of the wall plates at such points are removed to a width that is somewhat less than the thickness of the splice-center there to be placed, in order that the shoulders extending beyond

the sides of the engaging tenon of the center may furnish support against side pressure to the full cross-sectional area, and therefore to the full strength of the plates themselves. (Fig. 99 E and H.)

The posts are not framed, although they should be cut with precision and their ends properly shaped so that they may come truly to position and that the effects resulting from any twist of the timber may be removed. Almost invariably throughout the metal mines of the western United States gains are framed into plates and centers of the set into which the ends of the posts are boxed, the shoulders of these gains being employed to support the posts in place against the inward thrust of outside pressure. (See Figs. 98 and 99.) On the other hand, the general practice throughout the eastern portion of the country, in metal and coal mining, is to do away with this boxing of the posts, to frame no gains for their reception, but to set them flush with the top and bottom faces of the set, and to depend upon the tightness with which the assembled parts are blocked and wedged into position for retaining them in their places.

In practice certain variations of these several joints are employed, oftentimes to advantage, but the above discussion is intended to describe the practical methods of framing the typical rectangular shaft set.

SQUARE-SET PRACTICE AT BINGHAM, UTAH¹

BY LOUIS S. CATES

BINGHAM, situated in Salt Lake county, Utah, about twenty-five miles south of Salt Lake City, has become one of the largest low-grade copper camps in the West. The ore occurs in large shoots varying from 50 to 200 ft. in width, from 100 to 300 ft. in length, and in some cases proving to be continuous in depth for over 600 ft. These chambers or shoots in most cases have a well-defined foot-wall of quartzite and a hanging of limestone, although some have been found imbedded entirely in the lime. There is no well-defined dip to these bodies as with the veins, and they are found varying in dip from the horizontal to the vertical.

The ore is heavy, running about 9 cu. ft. to the ton, and carries on an average 25 to 30 per cent. iron, 20 to 25 per cent. silica, 2 to 5 per cent. copper, \$1 to \$3 gold, and 1 to 4 oz. silver. In mining this ore great care is exercised, for it is not uniform in texture, changing in a very few feet from hard compact sulphide to a soft disintegrated silicious ore, which, unless caught up, will run and cause a cave. The large size of the orebodies, the variable texture of the heavy ore, and the added disadvantage of having a heavy hanging wall, have made it necessary for the square-set system to be universally used in mining the large shoots.

The larger companies use finished Oregon pine timber which is framed before shipment, while the smaller ones frame their timber at the mine.

The sills are framed from 6x10-in. timber cut 5 ft. long, dapped 1 in. on each end and cut in 4.5 in. in order to support one-half of the posts on each end, as shown in Figs. 100 and 101. Occasionally, where long caps are used in order to leave out a

¹ From *Engineering and Mining Journal*, August 25, 1904, Vol. 78.

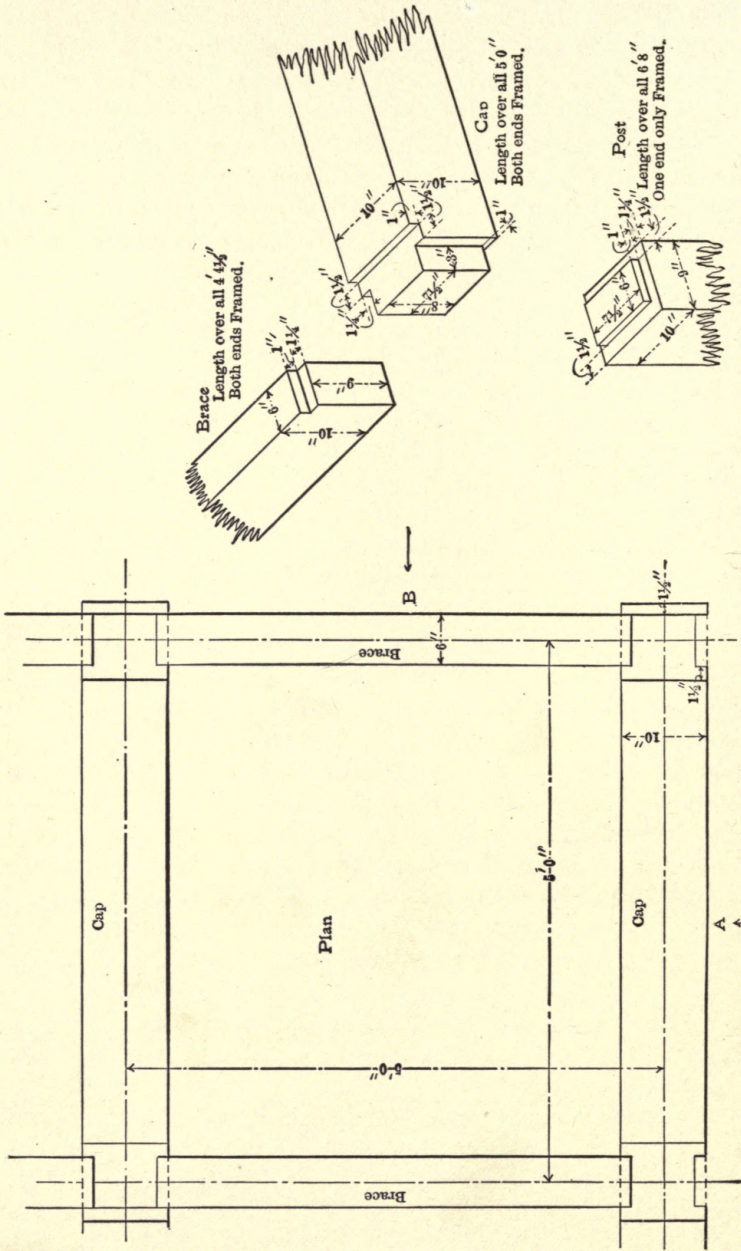

FIGS. 100 AND 101. — SQUARE-SET TIMBERING AT BINGHAM, UTAH.

post in the sets, so that a curve may be made in the track, a long 10-ft. sill is used. Posts are cut from 9x10-in. timber, 6 ft. 8 in. over all, and are framed on one end only, the base setting into the sills 1 in., and the top having a tenon 1 in. long and 6x7.5 in. The caps are framed on both ends, as shown in the sketches, from 10x10-in. timber, and since they are framed down into the posts 1 in. it is evident that the sets are 5-ft. centers on the sill and 7 ft. 4-in. centers in elevation. The braces are made

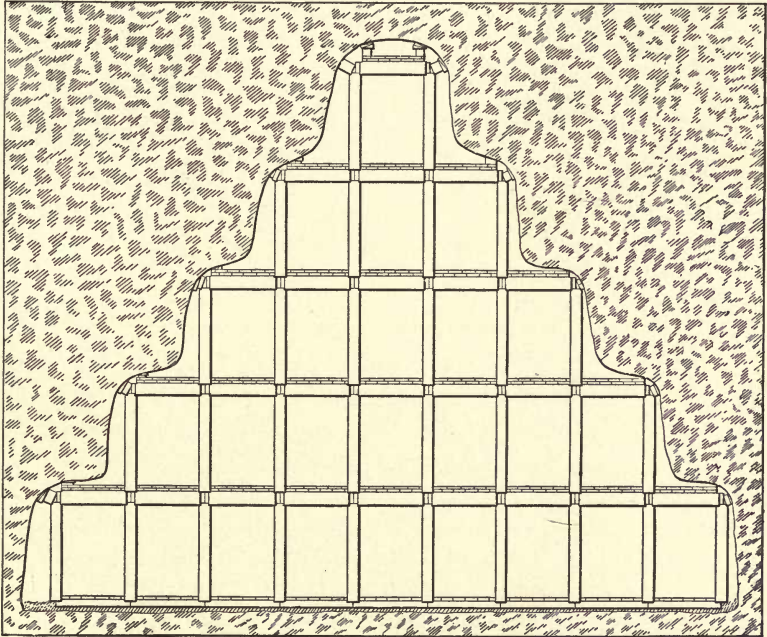

FIG. 102. — TRANSVERSE SECTION OF STOPE.

from 6x10-in. timber cut 4 ft. 4.5 in. and framed as shown in the sketch. For lagging, 2x8-in. lumber is used; any heavier than that is too strong, for it does not bend enough in event of great weight being exerted, nor give sufficient warning of impending danger.

The size and extent of the shoot having been determined, there are two methods of opening up the stopes dependent upon the character and dip of the orebody and the heaviness of the hanging wall. The preferable method, illustrated by Fig. 102,

is used where the hanging wall is firm and the ore solid, allowing large chambers to be opened up without danger of excessive pressure being exerted which would cave the stope. A definite level having been determined, the sills are laid for the first set at right angles to the general strike of the shoot. The sills are only 5 ft. long, for in most cases it is inexpedient to open enough ground ahead of the timber to lay longer sills. The sills in place and tamped down, a floor of single lagging is laid and the four posts erected. The caps are placed on the posts in the same relative position as the sills below, and braces are framed to fit the top of post and cap, thereby completing the square set; no braces or girders are used to keep the posts on the sills, but in their stead the floor lagging is laid from sill to sill, and a notch is cut in the lagging next to the post which acts as a foot brace and prevents any lateral motion of the post on the sill. A double floor of lagging is placed on the caps and braces and the set blocked securely, completing the first set of the stope.

This first set having been placed in one of the drifts, as near the center of the orebody as practicable, a row of lead sets is now started running longitudinally through the orebody; after this has been done, or the sets have been carried ahead four or five sets, another row of wing sets is started on one side of the lead sets, running parallel and adjoining them. The sill floor is opened up in this manner until four or five rows of sets have been carried along before stoping on the floors is begun. This method has been found more economical, for after once getting the lead sets through, there is an excellent opportunity to slice the ore off by simply starting another row of wing sets, and it affords more place for the machines to work than the second method.

The sill floor once opened up sufficiently, the first floor is opened up exactly as the sill, by driving a row of lead sets over the lead sets on the sill floor. Care is always taken to have the sill floor at least two and preferably four rows of sets wider than the first floor, thereby making it easy to keep the broken ore on the floors. The second and upper floors are then carried up, the object being to carry the lead sets right up to the middle of the body, thereby relieving the weight on the sill floor by resolving the downward pressure of the orebody into two components, a horizontal one resisted by caps and braces, and a vertical component resisted by posts. The stope then should resemble

a pyramid of blocks, with each lower layer extending one or two blocks beyond the next higher. After the lead sets have been carried up in this manner the floors are opened out by continual slicing until the walls are reached.

The second method, illustrated by Fig. 103, is used where the hanging wall is very heavy and there would be great danger

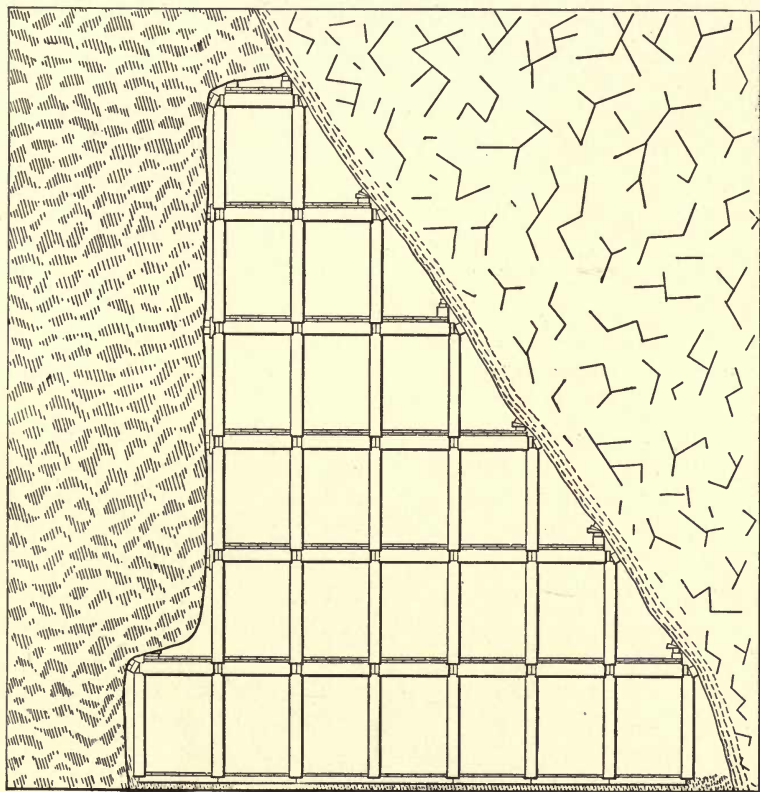

FIG. 103. — TRANSVERSE SECTION OF STOPE.

of a cave were the first method used, and especially where the nature and extent of the orebody is not known. In this case, as in the first, sills and caps are placed at right angles to the general strike of the shoot, but instead of starting at the center of the body the first set is placed as near the hanging wall as possible and the lead sets driven along the hanging. This row being driven ahead, a second row is started adjoining and parallel

to the first. After two rows have been driven, stoping is begun immediately by starting a row of sets directly over the second sill row and carried up by successive floors until the hanging wall is reached; when this is done, another row is driven on the sill floor and the sets carried up to the hanging wall. The stope is continued in this manner until worked out or it is advisable to cave it and start a new one.

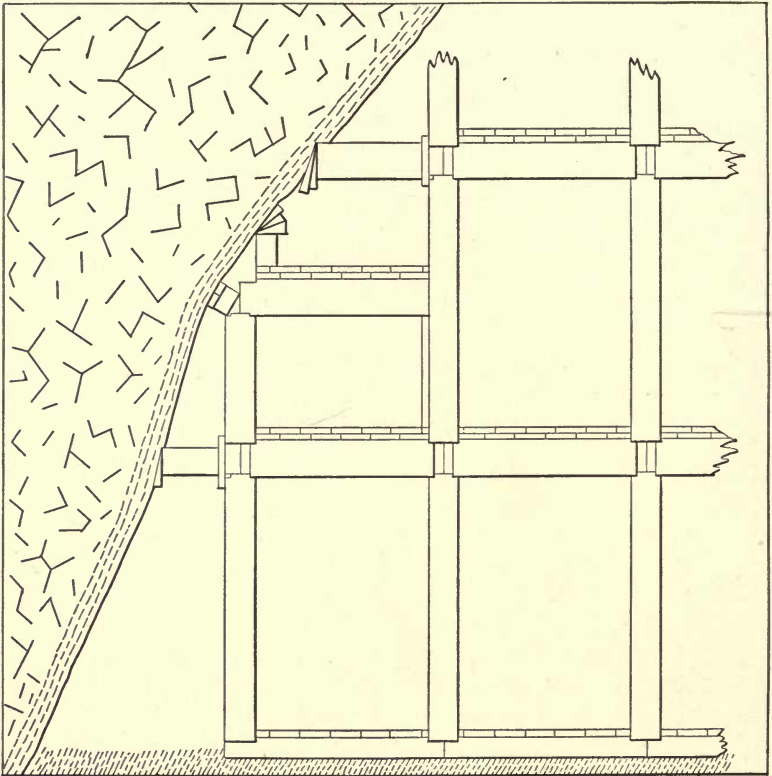

FIG. 104. — SHORT SETS.

The double advantage of this method is manifest. First, there is always a solid breast of ore on one side of the stope, which greatly relieves the pressure on the timbers; second, should the stope cave in unexpectedly, only the ore on the floors and in the chutes is lost, for a new stope can be opened up by driving a row of sets on the sill floor, right next to the caved stope, and then carrying them up to the hanging as before. On approaching

the hanging wall it is evident that it is not always possible to remove all the ore and catch the hanging wall up with full sets. In such cases short sets are used.

Formerly, when a short set was used, the post nearest the hanging was cut the desired length, and the post in the full set, into which the small set was framed, was cut the same length. The cap and braces were placed as in a regular set, then in order to complete the full set two small posts were framed into the small set. This scheme took a lot of time and weakened the posts of the full set.

In order to overcome this disadvantage, a method illustrated by Fig. 104 is used. A glance at this sketch shows that the post of the short set is placed in the usual position on the cap below, but instead of cutting the post in the full set in two, the tenon on the cap is cut off, allowing the cap to butt right up to the post. The cap is spiked to the post to hold it in position, and a piece of 2x8-in. lagging resting on the cap below is also spiked to the post and forms the support. To prevent lateral motion of the caps on the lagging, two pieces of 2x8-in. lagging are nailed together and spiked in position to be used as a brace on the end where the tenon is cut off, thereby holding the cap as securely as necessary. This method is simple and equally as efficient as the former, as it answers all the requirements.

When mining on the foot-wall, ground posts and butt caps or butt braces are used, depending on the steepness of the foot-wall. These methods are shown in Fig. 105. When the foot-wall is very steep, a piece of 10x10-in. timber is framed on one end as a cap or brace, as the case may be, to fit into the full set, the top is cut 1 in. deep and 9x10 in. to fit the posts, and the sides 1.25 in. deep by 6x10 in., or 1.25x9x10 in. to fit the brace or cap, and cut long enough to fit the hitch which is cut into the foot-wall, deep enough to make the butt cap or brace secure.

In cases where the foot-wall slopes off so much that it is impossible to place the butt cap, so that it is resting on solid ground at the point where the post is placed on it, the butt cap is framed as before, except that the bottom is cut 1 in. deep by 9x10 in. to hold a post which affords the necessary support under the post which is placed above on the cap. Frequently spreaders of lagging are placed, extending from the base of the ground post to the post of the full set, to hold it in position.

When a post shows signs of weakness, instead of putting in a false set to strengthen it, angle braces are used. For example, a post on the sill floor shows signs of weakness; the angle braces are framed to fit between the top of the post directly over the weakened one and its cap, and extend diagonally downward to fit between the cap and the foot of the posts on each side. In

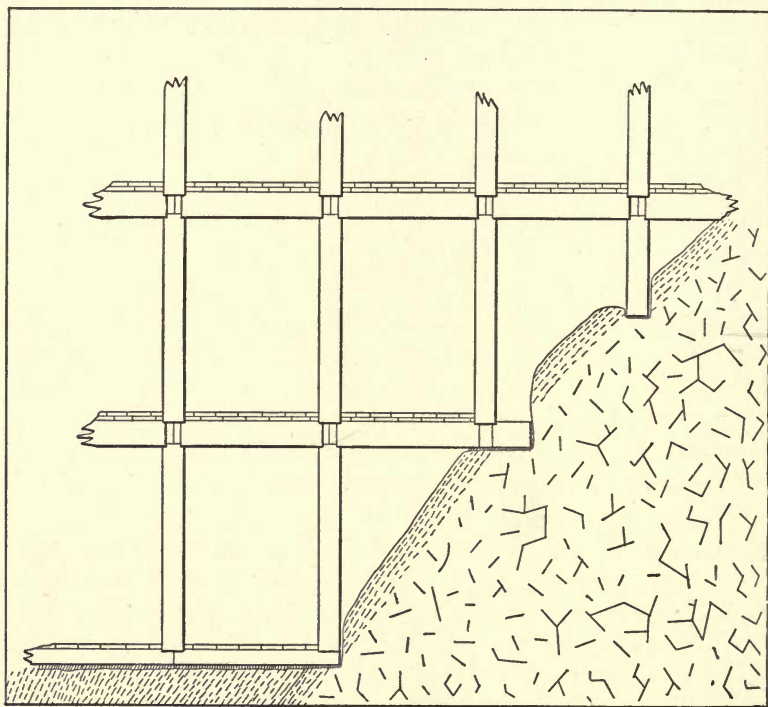

FIG. 105. — BUTT CAP AND GROUND POST.

this manner the load is distributed between two posts, and thus has the advantage over false sets, especially on the sill floor, of not decreasing the head room.

Economy is evident in all workings. For often, in shooting, a cap or brace is shot down on the post, injuring the tenon; instead of a new piece of timber being put in, the old one is knocked back in position, and a piece of lagging spiked to the side of each post upon which the injured member rests, reaching to the sill, or, if on the floors, a cap, thus forming a support on each end

and relieving the pressure on the broken tenon and keeping the injured timber in place.

In blocking the sets down, care is used to see that the timbermen always put the blocking as nearly as possible over the posts and never near the center of the brace or cap, on account of the leverage exerted on the timber, should the set take weight. When shooting, especially in hard ground, the timbers are faced with old lagging, and double floors are used to prevent large boulders breaking through the floors.

When much waste is broken in stoping, it is not run over the dump, but, instead, certain sets are lagged up to the hanging wall and the waste thrown in to be used as filling, making columns which greatly aid in holding back the ground. When a stope has been worked out, floors, pipes, ladders and everything movable are taken out and 1-in. holes bored in nearly all of the posts in the sill floor; powder is inserted and the whole round is shot by a battery, caving the stope.

SQUARE-SET TIMBERING AT BINGHAM, UTAH¹

BY CLAUDE T. RICE

AT present square-set timbering is mainly used in mining the orebodies at Bingham Cañon, Utah. As the orebodies are mainly replacement deposits in the limestone along mineralizing fissures, the walls of the orebodies are generally strong except where the limestone has been shattered by faulting. Because of this strength of wall, complete filling of the stopes with waste, such as is the practice at Butte, Mont., where in some of the square-set stopes the filling or "gob" is kept within two floors of the roof of the stope, is not required.

MINING METHODS

Consequently the orebodies of Bingham are mined without much waste filling, thus resembling the open square-set stopes of some of the Leadville mines where the ores also occur in limestone. Whenever a stope shows signs of a "taking weight" a few square sets are lagged and waste is dumped into this pen, forming a waste-filled bulkhead which helps materially to steady the stope. These "pen" bulkheads work so satisfactorily that I failed to see any wooden bulkheads such as are used in some of the Boston & Montana mines at Butte.

The chutes are simply plank-lagged square sets with occasional offsets to break the fall. Owing to the softness of these sulphide ores there is no excessive amount of cutting of the lining of the chutes, and consequently neither "bricked" chutes nor the open staggered chutes which characterized the open square-set stopes of the Homestake mine, at Lead, S. D., are necessary. Two-inch planks are used for floors in the stopes. Owing to the strength of the ore and the little tendency it has to scale off, the roof sets of the stope generally do not have to

¹ From *Engineering and Mining Journal*, Nov. 3, 1906, Vol. 82.

be lagged, another feature which makes the timbering and mining cost in Bingham Cañon square-set stopes much less than at Butte, Montana.

THE SQUARE-SET SYSTEM

However, the mine managers at Bingham have not been quite satisfied with these advantages, but have designed, in order to save timber, a specially framed square set, which, at least as

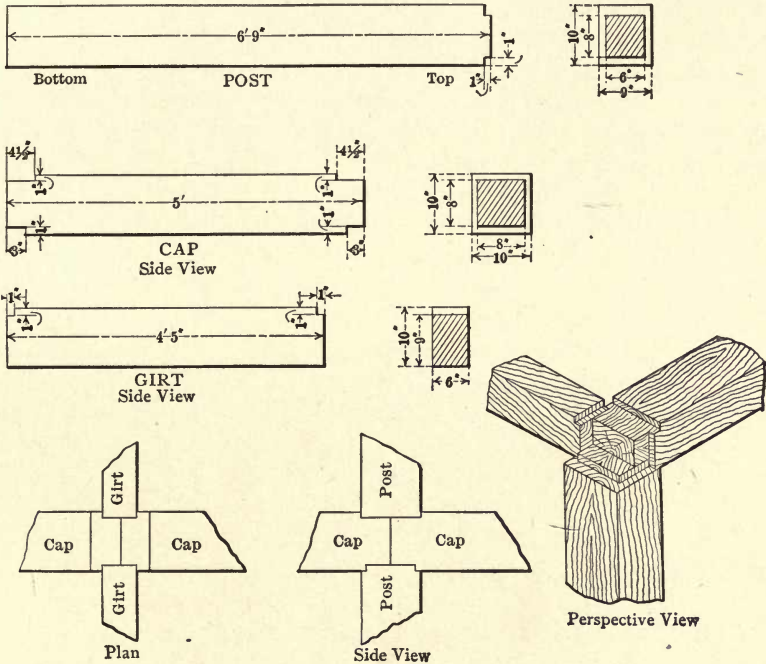

FIG. 106. — DETAILS OF SQUARE-SET TIMBERING.

far as my experience indicates, is peculiar to these mines. This system was first used at the Highland Boy mine of the Utah Consolidated and has later been adopted at the near-by Boston Consolidated mine. It has proved so satisfactory that the same framing of square sets is used at the Cactus mine at Newhouse, Utah, which like the Boston Consolidated is under the control of Samuel Newhouse.

On the Comstock lode the original square sets were framed as designed by Philip Deidesheimer, with the horns of the posts

butting against those of the posts below. This framing is still retained in the few square sets used at present on the Comstock. Whether the downward pressure there is greater than the side pressure, as the framing would indicate, I do not know, but I could not help noticing this feature of the framing of the original square sets, which to me at least is unique; for although I have worked in many mines, and visited many more, in which square-set timbering is used, I have not seen elsewhere this feature of butting the posts against each other.

PECULIARITIES OF THE BINGHAM PRACTICE

At Bingham Cañon the sets are designed to offer the greatest resistance to side pressure and so the horns of the caps are caused to butt against each other, the cap being 10x10 in. square. In this butting of the caps there is nothing unusual, but in the posts we have the unique feature of a piece rectangular in section instead of square, the post being 10 in. wide in the direction of the girts and 9 in. wide cap-ways, thus saving an inch in the cross-section of the posts. Moreover, the posts have a bottom and a top end, for they are "bald" at the bottom and have only a 1-in. horn on top. In consequence of this framing of the post, the top mortise made up by the assembling of the caps and girts differs from the bottom mortise, and so there is a top side and bottom side to the caps and girts. This at first confuses the green timber man used to caps without a bottom or top side, but of course this is no valid objection to this square set. Naturally, it is necessary to have a tenon on the top end of the post on which to rest the caps and girts. As the bottom of the post rests on the caps and girts it does not need to be framed, but it seems to me that it would be just as well to have the top and the bottom ends of the posts similarly framed with horns, for then there would be no such complicated arrangement of framing as the present design demands in the caps and girts. True, that would cause an extra pass of the post in the framer, but it would avoid the special framing of a cap only on the top side of the girt. If the similar framing of both ends of the post were adopted the girt would be a plain 6x10-in. timber resembling the girt used by F. A. Heinze at the Cora-Rock Island mine at Butte, Mont., where (if my memory be correct) the girts are plain,

8x10 in., and the posts are 10x10 in. with horns on both ends, and the caps are 10x10 in. butting up against one another.

CRITICISM OF THE SYSTEM

This making of the girt only 6x10 in. in cross-section appears to be a step in the right direction; for the purpose of the girt or tie, or, as it is better called in some camps, the brace, is mainly to resist the side movement of the caps and is not to resist any great inward pressure in the stope as is the function of the cap. Consequently the girt does not have to be as strong as the cap. In my opinion it is a waste of timber to make the girts equal in cross-section to the caps.

Another feature that strikes me as worthy of consideration is the fact that although the vertical distance in the clear between the caps and the posts is 6 ft. 5 in., the distance in the clear cap-ways and girt-ways in the sets is only a little over 4 ft. It might be possible to increase this distance, and effect still more economy in the timbering without endangering the stope, but this last matter of course is a point for men well acquainted with the ground to decide, and undoubtedly it has been given much thought by the Highland Boy management, which is noted for its high efficiency. I mentioned the point only because of the striking difference in these dimensions, which the managements of these mines have thought necessary. The only drawback to the girt being as narrow as 6 in. is the ease with which a floor can be torn up by a heavy blast in the stope, unless the floor is tightly wedged in place, for it has only a 3-in. hold when laid cap-ways. But this, of course, is a very small drawback.

All these timbers are framed at the mills in Oregon and Washington, and are shipped ready to go into the stopes.

The arrangement of the sets is shown in Fig. 106.

Owing to the fact that the dimensions were scaled to the timbers themselves and not taken from a drawing, there may be some slight mistakes (even $\frac{1}{2}$ in.) in some of the dimensions, but the dimensions of the sets are in the main correct.

MINE TIMBERING AT LAKE SUPERIOR¹

BY W. R. CRANE

MUCH timbering is done in the copper mines of northern Michigan, although in many of them the use of timber is confined almost exclusively to the shafts, pillars being depended upon for support of the hanging wall in the stopes. The problem of support of workings several thousand feet distant, vertically, below the surface is becoming more difficult of solution with the lapse of time, owing to the rapidly increasing area of workings only partially supported, and to a less extent to the collapse of the supports, pillars, or timber in the upper levels. The enormous loads thrown upon the hanging walls of large open stopes, which are supported by pillars or timbers of only a very small proportionate part of the total area exposed, must ultimately cause their disintegration, which, when it occurs, may start a movement that may be very slight, yet the results would be difficult to conjecture.

Where portions of the vein filling are left for support of hanging wall, the idea is to remove ultimately as much of it as possible before it collapses and before any fall of roof would interfere with the operations carried on below. No systematic attempt has been made to rob pillars, except in the filling system, in which case those left standing and finally removed are the floor or chain pillars. That none too large pillars are left for the support of the hanging wall is evidenced by the rapid breaking up of such unmined portions, and that, too, in the course of but a few years.

Timbering may be used as an auxiliary to pillars, and alone, even, as temporary support, and is in fact employed extensively both ways. Probably mine support by timbering is carried on most extensively and systematically in the Calumet and Hecla and the Tamarack mines, which are among the largest and deepest in the district. It would seem, after the disturbances which have

¹ From *Engineering and Mining Journal*, Nov. 10, 1906, Vol. 82.

recently occurred in several of the mines of this district, that ultimately filling of the stopes with waste must be the solution of the problem of support. No attempt is made in this connection to give details of all of the forms of timbering employed, but rather to make note of only a few typical forms which have come under our observation.

TIMBERING IN SHAFTS

The method of sinking practically all of the shafts through the surface materials, which are usually sands and gravels, is by drop shafts, consisting of frames and studdles forming sets, to which additions can be made indefinitely. These sets, when securely bound together by bolts and inclosed in a sheathing of lagging, maintain the shape and alinement of the shaft and keep out any quicksand that might enter otherwise. Below the point where the surface materials terminate, and where the shafts enter solid rock, often no timbering is necessary, for a time at least, the excavation being self-supporting.

The arrangement of the timbering used in self-supporting excavations is shown in Fig. 107. The long sleepers, running transversely with the shaft, are set in hitches cut in the sides of the shaft, and are carefully alined with the finished portion. Timbering in this manner is done in reverse order to shaft sinking, *i.e.*, is carried on from below upward, the object being to facilitate matters. Timbers are placed up to the rock pentice, which is left as a protection to the operations in the shaft below, and when it is removed, only a few pieces of timber remain to be put in place to complete the support of the tracks, ladders, etc. The

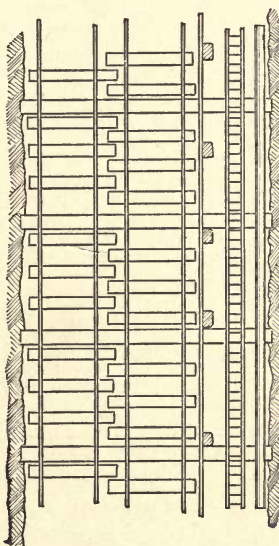
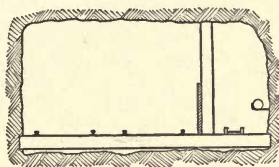

FIG. 107. — SHAFT TIMBERING. Plan and section.

alinement of sleepers placed in this manner is rendered considerably more difficult than if carried downward continuously from the finished shaft above, the work of alinement having to be carried on through the small sinking shaft and to a point 100 ft. below the end of the working portion.

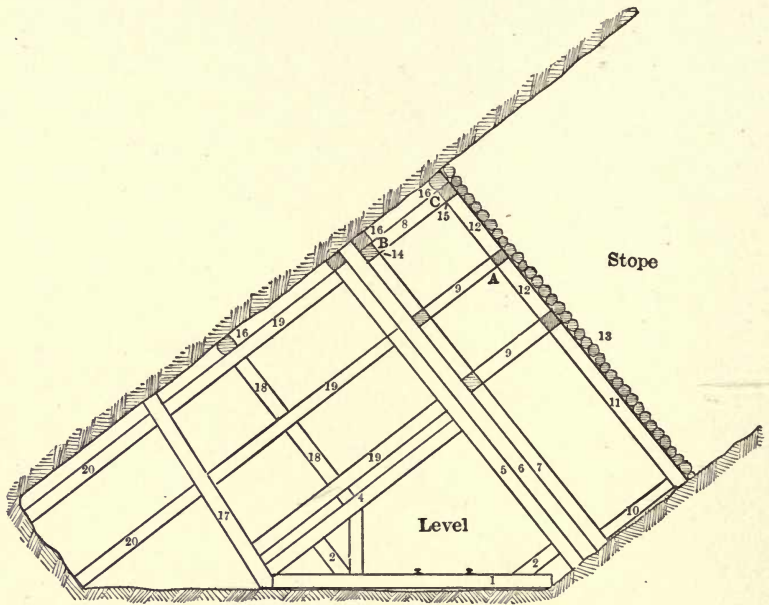

FIG. 108. — LEVEL TIMBERING AND SQUARE SETTING.

- | | | |
|-----------------|-----------------------|-------------------|
| 1. Sill | 8. Hanging Post | 15. Wall Plate |
| 2. Foot Knee | 9. Center Post | 16. Blocking |
| 3. Hanging Knee | 10. Studdle | 17. Stull |
| 4. Post | 11. Leg | 18. Post or Strut |
| 5. Stull | 12. Double Ender | 19. Flat Cap |
| 6. Filler | 13. Lagging | 20. Proprs |
| 7. Starter | 14. Bottom Wall Plate | |

The sleepers having been placed and securely wedged in position, the ties are next put in position, being set alternately with ends overlapping. The sleepers are 12x12 in. by 17 ft. 8 in. and are spaced 8 ft. apart, center to center. There are six 7x8-in. or 7x10-in. ties placed between two adjacent sleepers. A partition 4 ft. high separates the hoisting compartments from the manway, which is 4 ft. wide. Posts (10x10 in.), set between the foot- and hanging walls, support the 2-in. planking of the partition, which serves as a protection against falling rock

to men passing up and down in the manway. Wooden ladders are fastened to the sleepers as shown in Fig. 107.

On the up-shaft side of the sleepers are fastened planks, which extend from the top of the sleepers to the bottom of the shaft excavation, thus dividing that portion of the shaft flush with the tops of the sleepers and ties into sections or pockets, as it were, by the plank dams. These sections are filled with fine mine dirt, the placing of the dirt being accomplished by a small skip of about two tons capacity, which is provided with a small gate at the lower part of the rear end. A load of dirt is hoisted to the point in the shaft desired and the gate is opened by simply unlatching it, when the dirt runs out and is spread largely by gravity.

CONCRETE LINING

When the shaft excavation is not self-supporting, the framing employed in the quicksand and other surface materials, or similar forms, is resorted to, usually, however, without lagging. Aside from timbering, concrete linings are occasionally employed, which reach from the surface to bed rock, with which connection is made, thus effectively shutting off the water that is often encountered in large quantities in the loose surface accumulations of gravel and sand. Concrete is also used in the rock excavation of shafts, where it serves as support for the tracks, being built either in transverse ties or longitudinal stringers for the rails to rest upon and be fastened to by long bolts passing through plates in the body of the structure.

TIMBERING IN DRIFTS AND STOPES

In the workings, *i.e.*, levels and stopes, timbering takes the form of stulls and square sets, and all imaginable combinations of the two. In the deeper levels of the Tamarack mines, stulls, both in the form of individual members and in groups of three or four, set close together (commonly known as batteries of stulls), are extensively employed. The batteries are spaced from 8 to 10 ft. apart and may be used in combination with individual stulls. Stull timbers range in size from 1 to 4 ft. in diameter. They are carefully measured and cut on the surface, and then carried below and set normal to the lode, being wedged fast.

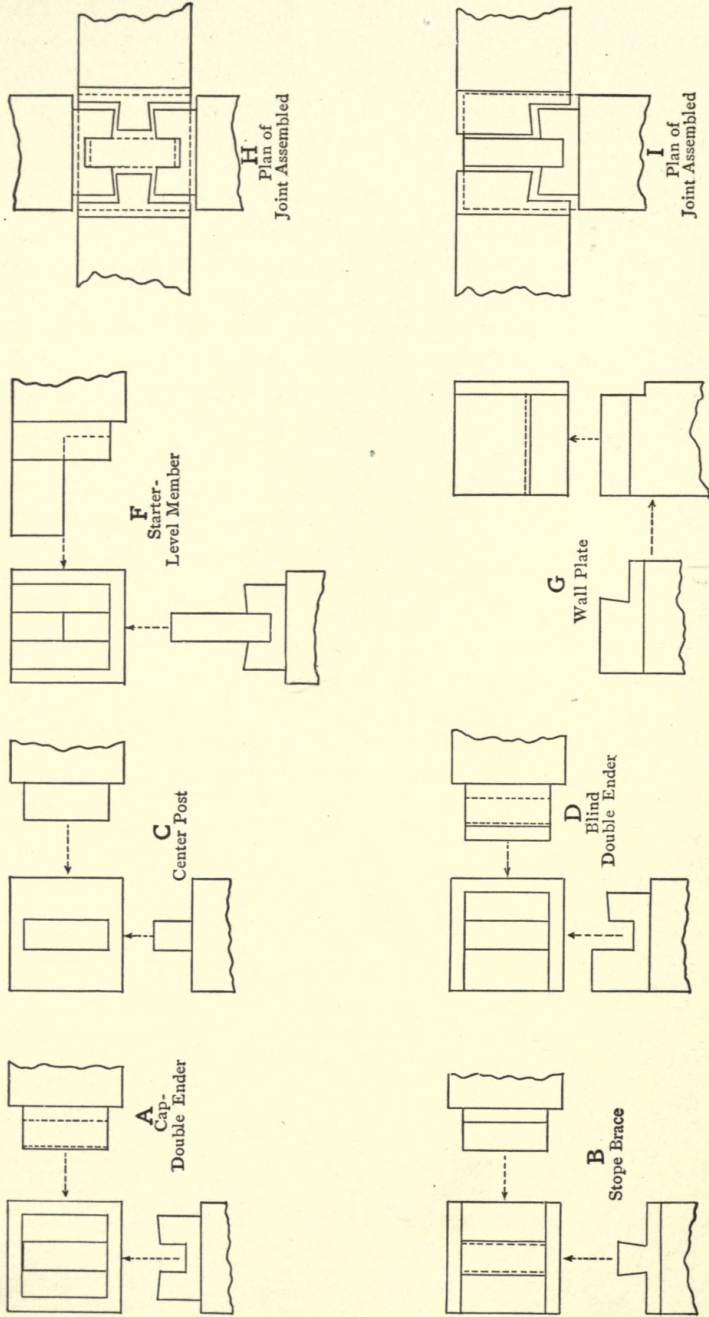

FIG. 109. — FORMS OF SQUARE-SET JOINTS.

The arrangement of timbers employed in levels, which serves as a basis for the building of square sets in stopes, is shown in Fig. 108. Further, square setting may be stopped at any time and the face of the timbering covered with lagging as shown. One form of square-set joining is shown in Fig. 109. The forms of the individual members are shown in three projections each, from A to G, while in H is shown a combination of A, B and C (a joint for a standard set), and in I are grouped F and G and a form of C. The arrangement of timbers shown in H is a plan of the joint at A, Fig. 108, while in I is shown a plan of the joint B. The blind double ender D is used with B and C in joint at C. In H and I the dotted lines represent the members above and below the plane of the plan given, always similar, but not necessarily vertical.

Timber caps, or wall pieces, usually rough round logs, are also employed, being supported by pack walls built along the lines of the levels. A lagging of rough poles is placed on the caps and waste rock piled on these in turn. Levels are thus formed and maintained in the Baltic and Trimountain mines, where filling methods are employed; often as much as 30 to 50 ft. of waste filling may rest upon the caps.

Timber as a means of support for the mines has a wide range of usefulness in this district and will always be an important factor in mining regardless of the methods employed.

TIMBER AND TIMBERING IN THE COEUR D'ALENE¹

BY J. H. BATCHELLER

THE timber principally used is fir and tamarack. Bull pine, in large sticks, seems to mildew and rot too rapidly for good service, though in the form of planks, spiling, track ties and wedges it does well enough. Fir and tamarack seem to resist decay equally well, even in old workings. There is, however, one limitation to the use of tamarack: it bears end pressure well, but is too brittle to give good service under any side or transverse stress. Because of this failing, tamarack is rarely sawed into square timbers, such as caps, ties, etc., but it is cut into posts, stulls, helpers, angle braces, sprags, poles, chute cribbing and chute lining. Fir not only serves for all of the above, but is also cut into sills, caps, ties, and plates.

In a general way, there are four different principles recognized as making for economy in timbering: first, the utilization of all the products from cutting the raw material; second, the use of simple, framed joints; third, the adapting of the size and number of timbers used to the duty required; and, fourth, the use of a uniform system of timbering throughout the mines.

The saving under the first head is accomplished in the following way: The trimmings made in squaring timbers are cut into 5-ft. lengths called "slabs," which are used in covering square sets under bulkheads, and in cribbing waste-fillings. The ends of large round timbers — too short for squaring into caps, ties, or collar braces — down to about 2.5 ft. in length, are framed with a top tenon 4x4x7 in. long (Fig. 110) on one end and left flat on the other. They are used for foot-wall stope-set posts (Figs. 115 and 116). Ends shorter than 2.5 ft. are cut into wedges.

¹ From *Engineering and Mining Journal*, Sept. 15, 22, 29, 1904, Vol. 78.

The planks — 2, 3 and 4 in. thick — are purchased ready cut. The 2-in. planks are used in chutes, flooring, and as spreader boards in tunnel sets. Three-inch planks, 5 ft. long, are employed for flooring and short chutes. Three- and 4-in. planks 8 and 10 ft. long are used in temporary slide chutes in newly started stopes, before they are cut out high enough for permanent cribbed chutes. The lagging is split cedar, 5 ft. long, and used in bulkheads (Figs. 113, 114 and 115), waste cribs,

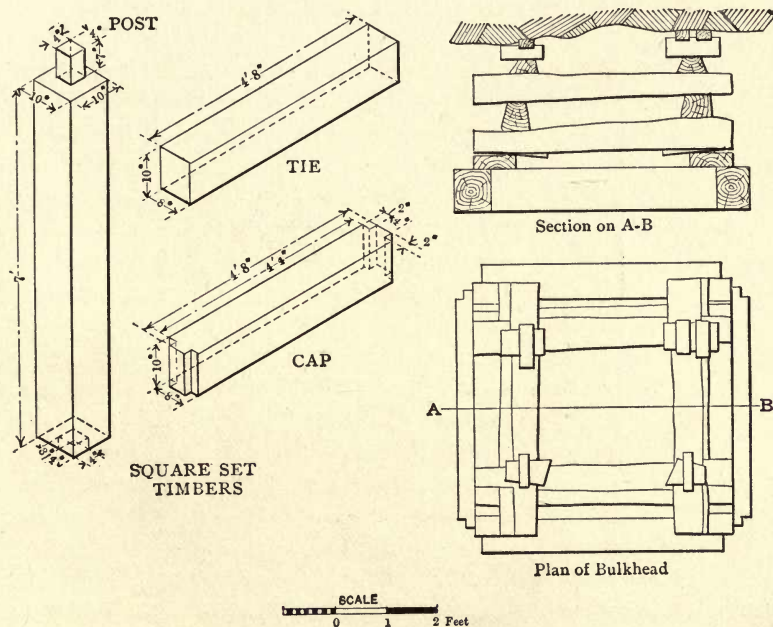

FIGS. 110-114. — SQUARE-SET TIMBERS.

and as temporary sprags and blocks, around newly erected square sets. The economy of material is almost perfect. A given stick of round timber will yield but little to go into the refuse pile, as the series of useful articles runs from quadruple ties 19 ft. 8 in. by 8 ft. 10 in., down to short chute cribbing 3 ft. 10 in. long by 4 in. diameter.

Under the second principle governing economy, a system of framing has been worked out to conform with the idea, first, that the less the end of a timber is cut to make a joint, the stronger the joint; and, second, that all joints are a source of weakness.

Simple joints not only economize material, but cost less in framing and in labor of erecting. Under the first, note the framed ends of the square-set timbers (Figs. 110, 111, 112 and 115), of the tunnel-set timbers (Figs. 118 and 119), and of the shaft set timbers (Figs. 120 and 121).

In the framing of square sets there are several advantages in having the top tenon of the post longer than the bottom one. This arrangement leaves only a shallow hole, the bottom of which is easily reached with the fingers, to be cleaned out of the joint to make ready for stoping a new post. At the top end, the longer tenon not only gives a better hold on the newly placed cap and tie, but also gives a better chance to block the post itself to the

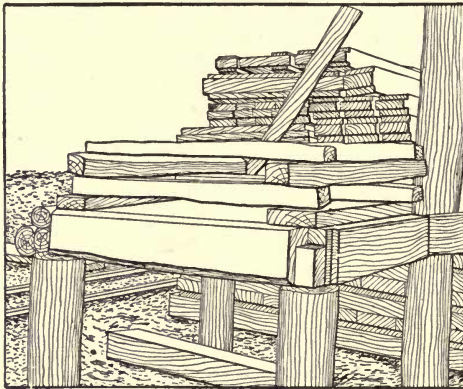
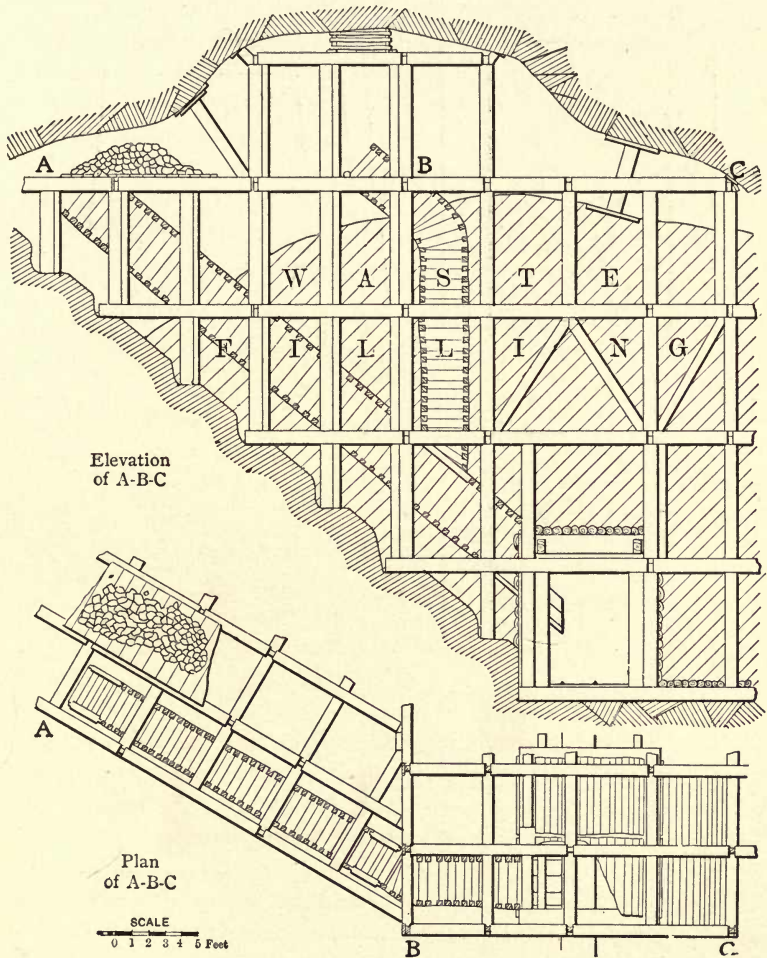

FIG. 115. — SQUARE-SET TIMBERS.

ground. The straight tunnel-set timbers have no framing whatever save only the shallow notch cut on the inside of the posts, at the top. This serves merely as a shoulder on which the spreader board can rest. In the battered sets, the under side of the cap is notched at the ends, to leave a portion in the center for a spreader to the posts; then the ends are beveled merely enough to give the square ends of the posts a firm seat. In both styles of sets, the full cross-section strength of the posts is retained. The loss of strength to the cap of a battered set, from notching the under side at the ends, is partially made up by its having less distance to span than the straight-set cap. The inclined-shaft sets are of far greater strength, under this system of framing, than under the vertical-shaft system, where the plates are

joined with half-splice tenons. This method is possible in inclined shafts, where the end plates carry but little side pressure, and it gives full cross-section strength to the timbers holding the wall plates.



FIGS. 116 AND 117. — SQUARE-SET STOPE.

In recognizing that all joints are a source of weakness, note the use of double, triple, and quadruple ties (Figs. 116 and 117). At first thought, it might seem that this point does not concern the matter of "simple framed joints." However, as there is a

limit to the length and size of timbers that can be used, there will have to be many joints. By using long ties, the joints where they are supported by helpers are the simplest and strongest for

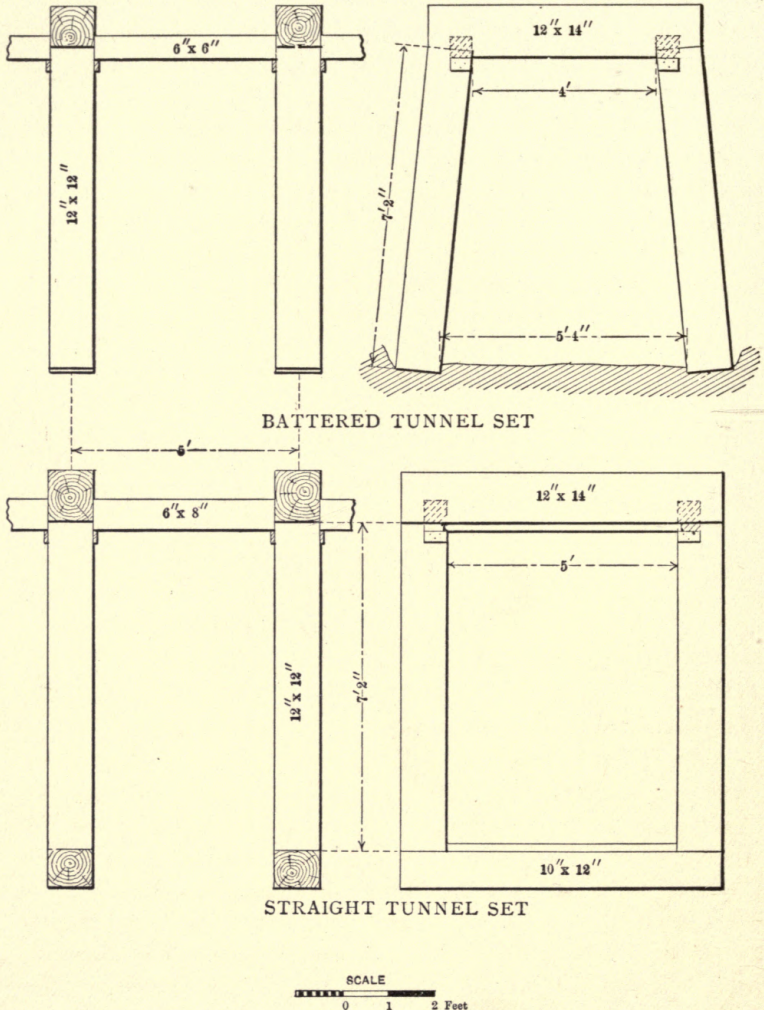

FIG. 118. — BATTERED AND STRAIGHT TUNNEL SETS.

the work, as they are merely butt-end bearings. Owing to the limited size of the drawing, no full-length quadruple tie is shown in Figs. 116 and 117. They are, however, extensively used on

the sill and second floors of stopes. Above the second sets in a stope, they become impracticable because their length makes them too difficult to handle. Triple ties can be used in many places for three or four sets up, but at last they, too, are discarded when it becomes too difficult to get them into place. Double ties can be turned anywhere, and are used wherever possible.

The third principle — that of adapting the size and the number of timbers to be used, to the duty required — is illustrated in every feature of the methods of timbering, and constitutes one of the most important points of economy. The term "duty" must be understood to mean not only the amount of immediate weight a timber must hold, but also the probable

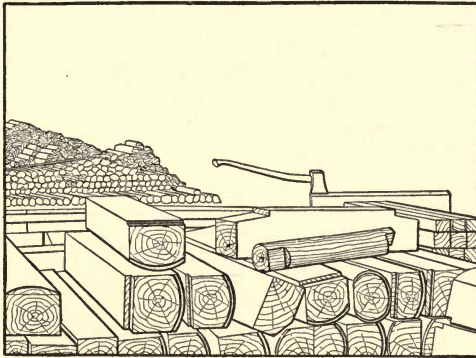

FIG. 119. — TUNNEL-SET TIMBERS.

future weight and length of time it will be desired to hold. Note (Figs. 116 and 117) how the light stope sets are used like stagings to work on, while the weight of the ground is carried principally by the waste filling. Where the ground gets too heavy for the stope sets alone, the small, inexpensive, unframed helpers and angle braces are put in alongside of the square-set posts to give local relief, sufficient to serve until filling is completed around these places. On the top floors, wherever suspicious pieces of ground threaten to fall in large masses, big stulls, sometimes footed against the timbers, and sometimes on the filling, are put in temporarily until the ground is taken down and square sets erected.

Two sizes of helpers are used: Center helpers, 8 to 10 in. butt diameter; and side helpers, 6 to 8 in. diameter. Center helpers

are placed under the long ties, in the positions where framed posts would come, if the sets were of short length. Side helpers are put next to framed posts to hold up the failing ends of caps and ties. Angle braces are put in to prevent the sets from "riding" (or leaning). The tops and bottoms of the posts, against which they are set, must have either tenons or sprags to hold against the side thrust. This merely means that angle braces do no good if placed against the flat-bottomed helpers unless the latter are strongly held from being pushed out of position. Sometimes two angle braces are put in to lean against

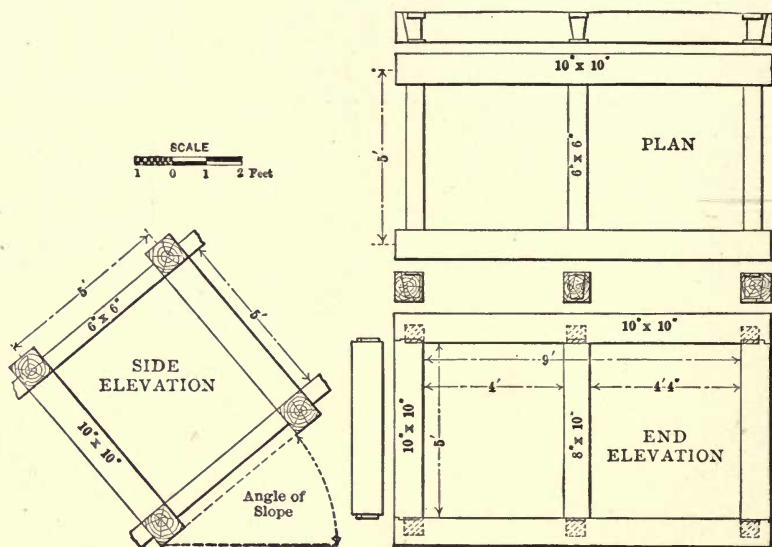

FIG. 120. — TWO-COMPARTMENT SHAFT.

each other, like a triangular truss, to take the place of a post, or center helper (Figs. 116 and 122). In this case the object is to take all possible weight from above the center of a drift and transfer it to the sides. All angle braces, stulls and helpers are sawed to measure at the time of erection, and are cut to drive home tight. They are always put in butt-end up, as it has been found they do not split lengthwise as readily that way as with the small end up.

The use of long ties — when the ground does not break too short to be opened up sufficiently — offers a number of advantages. Not only does it save one, two, or three framed posts,

respectively — as the ties are double, triple, or quadruple length — but also just twice the number of caps as posts (that is, two caps for each post). Further, there is a saving in size of the timbers put in the place of the posts. The strength of a 9-in. center helper is greater than the transverse strength of the 8x10-in. tie on top, for the latter will almost invariably break first, or mash down, or turn over, before the helper fails. This is a saving of two inches in the diameter of the timber, for framed posts, on an average, are never less than 11 in. in diameter when

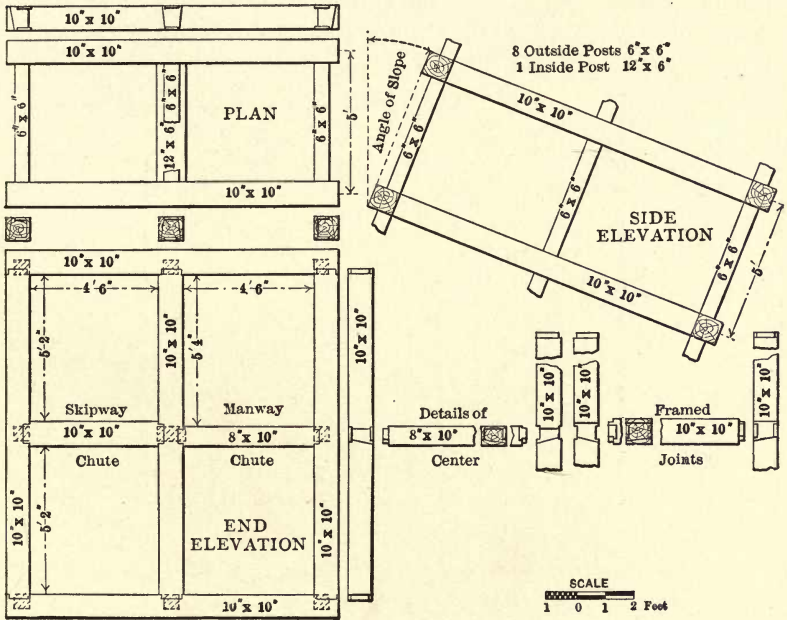

FIG. 121. — FOUR-COMPARTMENT SHAFT.

round, and they are, of course, cut from still larger timber when squared to 10x10 in. In place of the two caps saved where each center helper goes, small sprags or girts are put in and driven tight.

Besides the matter of economy, the long ties have the advantage of greater strength. Where a tie extends over the top of a helper, all the top fibers of the timber lend their tensile strength to the others in the span, which is not the case where a joint occurs. The use of long ties has also a marked tendency to

stiffen the stope timbers, and makes it easier to hold them all in good condition till filling is completed. This advantage of stiffening the stope timbers amounts to a great deal where cribbed chutes come up every four sets, from one end of the stope to the other, parallel with the pitch of the ore shoot. As ties are always placed across the stope — from foot to hanging — the chutes come up between them. The slope of a chute often necessitates the removal of a cap, thus greatly weakening the joints of the two sets on either side. However, where long ties are used on either side, at the point where a chute crosses a set, there are no caps in the way, and the girts are moved merely enough to give clearance.

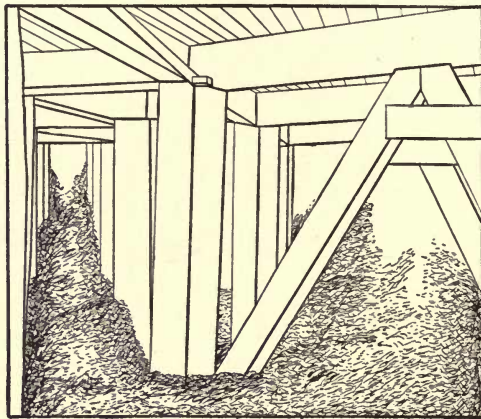

FIG. 122. — ANGLE BRACES.

The system of using double drift sets (Figs. 116, 117 and 124), at points where long life and power to bear great weight are desired, is another important feature in the timbering practice. These sets are usually put up only where a drift or a station is to be kept open for a long while under a filled stope. As the outside posts and cap in no way affect the inner set, the single set undergoes no break or change where it joins or leaves the double portion.

The use of a uniform system of timbering permits of a saving not only in material, but also in labor. All stope, drift, adit, and shaft sets, and stulls holding filling, are put in 5 ft. apart — center to center. Flooring planks, slabs, lagging and poles are cut a bare inch short of 5 ft. long; so that they can be used equally

well in all parts of the mine. Another, though minor point, is that the caps and ties are of the same cross-section; therefore, if required, a cap can always be framed from a tie. The uniformity of system lessens the amount of dimension stuff necessary to hold in stock, and saves many minor delays to the timber gangs underground.

The foregoing remarks cover some of the details of the methods, but are concerned mostly with their economic side. There is, however, an equal or larger number of points that are of great importance to the efficiency of all timbering. Attention can best

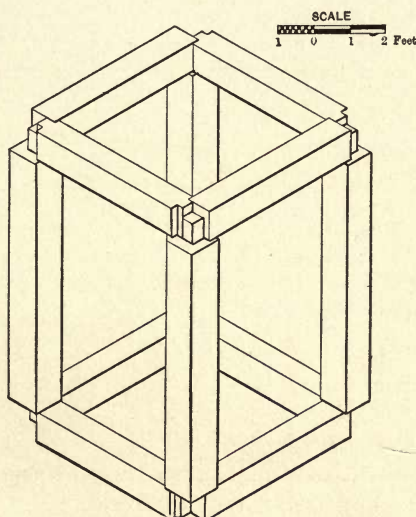

FIG. 123. — STANDARD STOPE SET.

be called to some of these in connection with a running comment on the accompanying figures.

On comparing Figs. 110-114, 116, 117 and 123 with Figs. 115 and 122, it will be noticed that the latter show round stope-set posts, while in the former they are shown square. They were drawn square purely as a matter of convenience, and, furthermore, though not especially common, posts 10x10 in. square occasionally come in from the sawmill. The average size is 11 in. butt diameter. This does not occasion any loss in strength to the square sets. The cross-section area of the 10x10-in. stick is only 100 sq. in., as against 95 sq. in. cross-section of the 11-in. round post. Examination of the details of the bearing

surfaces of caps and ties shows that on a 10x10-in. post each cap will cover 16 sq. in., and each tie 24 sq. in. The total area of cross-section can be accounted for as follows:

2 caps at 16 sq. in. each.....	32 sq. in.
2 ties at 24 sq. in. each.....	48 sq. in.
1 tenon, 4x4 in. square.....	16 sq. in.
Total surface bearing weight.....	96 sq. in.
Balance remaining unused.....	4 sq. in.
Total cross-section area.....	100 sq. in.

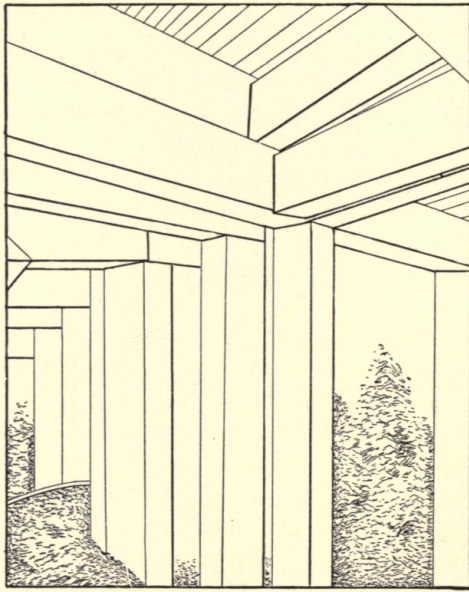

FIG. 124. — DOUBLE DRIFT SETS.

For all practical purposes the 95-sq. in. cross-section of the 11-in. post gives as good service as the 96-sq. in. useful bearing surface of the 10x10-in. post. There is yet another advantage, besides the economical one already pointed out. Of the two sizes, the round post, though smaller, will invariably be the stronger, because it possesses all the strength of the original outside fibers of the timber, while the squared post is weakened by having them cut.

The figures given above show that the ties have 50 per cent. more bearing surface on the posts than the caps. This fact

indicates clearly the reason why bulkheads should always be started from the ties rather than across the caps. In the details of a bulkhead (Figs. 113, 114 and 115), observe that the planks from which it starts are laid across the ties. In erecting, the lagging is cribbed up till there is not room for more, then blocks are put in and wedged as tight as it is possible to strike them. Owing to their inconvenient position, it is often impossible to jamb the whole bulkhead tight by means of the top wedges alone. To accomplish this, wedges are driven in at the four corners below, over the planks, and the whole structure is keyed up tight. This is of prime importance, for the bulkhead is needed, not only to hold the ground from slacking away, but in steadying the square sets from swinging when shots are fired near by. It is also important that all newly erected timbers should be tightly blocked and spragged from the ends to the ground; likewise all flat-bottomed posts and helpers, wherever they may be in danger of being shot out. It is only by holding all timbers rigid that stope sets can be held from "riding." When once "riding" starts, it is not only difficult but expensive to stop.

The foundation planks of a bulkhead are usually cut with a saw, 5 in. back from each end, 5 in. deep, on the sides that overlie the caps; so that when a new post is to be erected on top of one of those by the bulkhead, one blow from an ax will knock off the 5x5-in. block, and make room, without chopping the grit-covered planks, for the foot of the post. As the cedar lagging is softer than the wood in the planks and timbers, the condition of a bulkhead always gives first warning, by its state of compression, of the square sets taking any excessive weight. Though not shown in the drawing, slabs are frequently used across the ties, between the foundation planks, to serve as a covering to the sets. These slabs never carry any of the weight, but merely keep small rocks from sloughing off on the men below. Bulkhead material can be used over and over, till too badly crushed and broken to bear weight. After that it — and all other useless truck — is thrown into the waste fillings. Where long ties are used, bulkheads are built in exactly the same manner, in units; only two, three or four are erected to correspond with the length of the tie.

Figures 116 and 117 show some features of interest. After

the timbers around and above the tunnel sets were well secured by filling, the direction of the sets was changed from having the ties point perpendicularly to the direction of the adit and the strike of the vein till the ties lay parallel with the axis of the ore shoot. The pitch of the orebodies rarely coincides with the dip of the foot-wall. Most commonly it lies at some oblique angle. Where the erection of angle sets begins, it is sometimes necessary to use horizontal braces or sprags, from the straight (the original) sets, diagonally or cornerwise through the angle sets over to the foot-wall. This diagonal bracing ceases naturally when the original straight sets are worked out against the hanging wall of the stope; and the connection between the two classes of sets is held by filling.

The particular advantage of turning the sets lies in the possibility of keeping the chutes always along in the stope, and those that start in the stope at the sill floor can be carried clear up to the level above. If the sets were continued as begun, perpendicular to the strike, the chutes at one end of the sill floor would soon run into barren ground above the ore shoot, while at the other end the stope would soon reach diagonally up and beyond the last chute started in ore on the level. From this level, on this side, it would then become necessary to run raises through barren ground in order to get chutes up to the stope for ore. There would be no way to avoid the condition, for the ore chutes could not well be made small enough to turn diagonally up through the stope sets without their being too small for any service.

Two sizes are used, known as foot-wall and hanging wall chutes. The former are 4 ft. high by 3 ft. wide in the clear inside, and the latter 3x3 ft. inside. The chute cribbing is round and varies from 4 to 10 in. in diameter. The ends are sawed so as to leave a flat tenon 5 in. long by 3, 4, or 5 in. thick, according to the diameter of the stick. (Fig. 119.) With a 5-in. tenon on each end, and the inside clearance of 3 and 4 ft. respectively, the cribbing measure is 3 ft. 10 in. and 4 ft. 10 in. The inside clearance between stope posts and ties is practically 4 ft. 2 in., so there is ample room in which to build chutes and make the turn necessary where the angle sets start away from the straight sets. Manways are made in exactly the same way as the foot-wall chutes, 4x3 ft., but are always built entirely

separate from them on the foot-wall. The hanging wall chutes are made as branches of the foot-wall, so that all the ore can be handled from one gangway.

Sometimes stopes are started from the sill floor in a slightly different manner from that indicated in Figs. 116 and 117. Sill-floor posts 8.5 ft. in the clear, with flat bottom and a 4x4 x7-in. top tenon, are used. On top of these regular stope-ties and caps are placed. Pillars of cribbed filling are put in to hold the stope above, and a heavy covering floor is laid over the gangways and stations left open between the pillars. On top of the pillars and heavy flooring are laid the stope sills proper, for the regular 7-ft. square-set posts, entirely independent of the sill floor below. When this procedure is followed, the single tunnel set is usually enough, and the cap is braced by means of an extension or heavy sprag put in against the end from a hitch cut in the foot-wall.

However a stope may be timbered above, it is always started on good sills. These are covered with stout poles to hold the filling against the time when the ore in the floor will be taken out by stoping from a level below.

In closing the comments directed solely to stope timbering, there are some interesting points worthy of comparison between the 7-ft. clear sets used in the Bunker Hill and Sullivan Company's mines, and the 6-ft. clear sets used by some other mining companies. It must be remembered that in each case the thickness of the flooring planks must be deducted from these measurements, which leaves these sets with 6 ft. 9 in. walking room, as against 5 ft. 9 in. in the clear for the others. The longer posts give greater efficiency to the working powers of the men in the stope. For example, only an exceptionally tall man would be unable to walk erect, with timbers or steel on his shoulders, in a 6 ft. 9-in. clearance. Furthermore, angle braces frequently have to be put in where a passageway is being used to reach a chute. A 7-in. angle brace put in across a 7-ft. square set, still leaves room for a man to run the average sized iron wheelbarrow under it; while the same timber between 6-ft. posts would stop the way.

As a matter of economy, the longer posts are desirable. It would take only 41 posts 7 ft. 10 in. long to gain a vertical height of 321 ft. 2 in. against 47 posts 6 ft. 10 in. for the same distance. This means a total saving of 6 long posts, or of one 7 ft. 10-in.

post in every 53 ft. 8 in. In a stope of given height, there is not, of course, any saving in the number of feet of timber put in vertically, but the use of the longer posts saves the cost of one complete floor for the whole stope — caps, ties, general material, and labor — in every 53 ft. 8 in. vertical.

Figure 118 needs but little comment. The battered tunnel sets are the cheaper, both in material and in the amount of ground necessary to be broken out. The posts are frequently given more batter, where the ground is softer and has more side weight. The drawing represents the minimum amount.

Since they are not put up on sills, battered sets are not used in places where the floor will be worked out from below. The straight tunnel sets have top and bottom spreader boards spiked to the caps and sills. There are several sizes used in the mines, varying slightly in the height of the posts as well as in the dimensions of the timbers. The choice of a given size is governed by the place where the sets are wanted, and the duty they must fulfil. Double tunnel sets are made by placing an extra large straight set outside of the ordinary single set. Figures 116, 117, and 118 show the double sets, and 7-ft. square sets erected side by side from the same floor. The principal point is that tunnel sets of any style should always be made, as nearly as possible, free and independent of the stone sets; so that any settling or swinging of the latter will not affect the gangway.

The inclined shaft sets shown in Figs. 120 and 121 have already received comment. Where the inclination is not too great, the V tenon and mortise joint can be omitted, and then a two-compartment shaft set becomes nothing more than a two-compartment tunnel set, on a slope instead of horizontal. This latter method of timbering is successfully used in one 45-degree shaft. The limits governing its general use would be the amount of side pressure the end plates would have to carry, and also the increasing difficulty of erecting as the slope becomes greater; since there would be no V tenons and mortises to hold the end plates from dropping out while the set was being blocked and wedged.

Figures 125 and 126 show the general arrangement of the timbers at shaft stations on levels. The dotted lines in Fig. 126 show the chutes cut in the rock, just outside the shaft covering, connecting the places where the cars are dumped at the station with the chutes in the bottom compartments of the shaft.

Figures 127 and 131 show some points in detail that are quite common in use. Figure 127 shows how segments should be framed to support a long station cap, when the load is uniformly distributed along the cap. The plane of the joints should be so cut as to bisect the angle formed by the intersection of the two

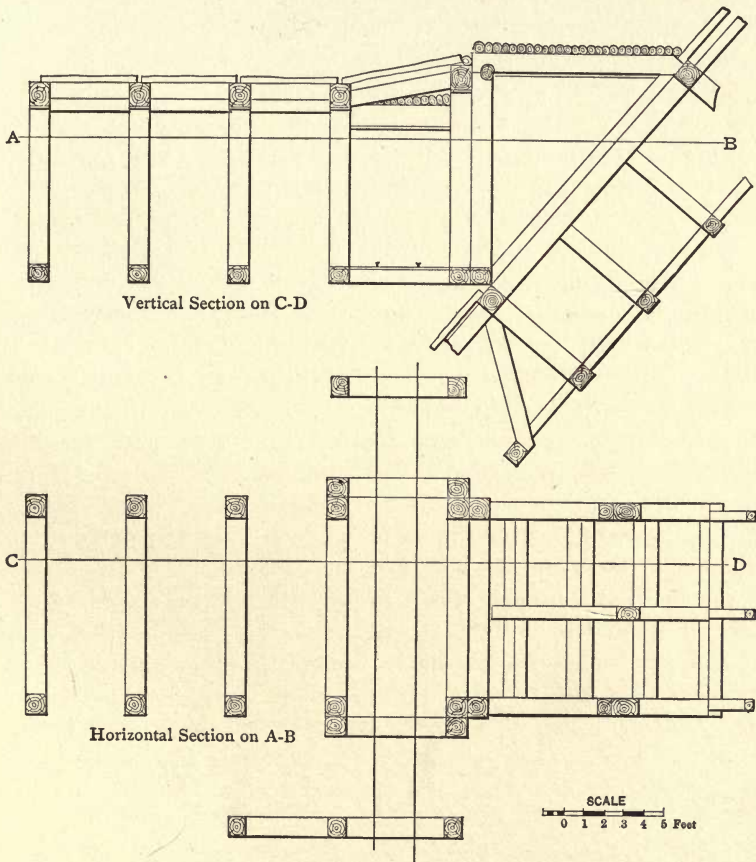

FIG. 125. — TWO-COMPARTMENT SHAFT STATION.

adjacent segments. This practically gives them the same shape and carrying strength as an arch. Figure 130 shows at a glance how the framing should *not* be done. The center segment would not carry any load, but would act merely as a spreader. Furthermore, the vertical side segments would carry but little weight, while the sloping side segments would thrust almost entirely out-

ward. Figure 129 shows the manner of holding up stope timbers so that a post can be cut off. There is no opportunity for choice as to how the top ends of the sloping segments should be framed, but at the bottom ends a method is shown which is better than in Fig. 130, though not as good as in Fig. 127. The only advantage of this method in Fig. 129 is that the vertical side segments do not have to be as large timbers as in the others. For the sake of simplicity in the drawings, it is not indicated that the posts of sets must be held against the side thrust of the segments by fillings or sprags.

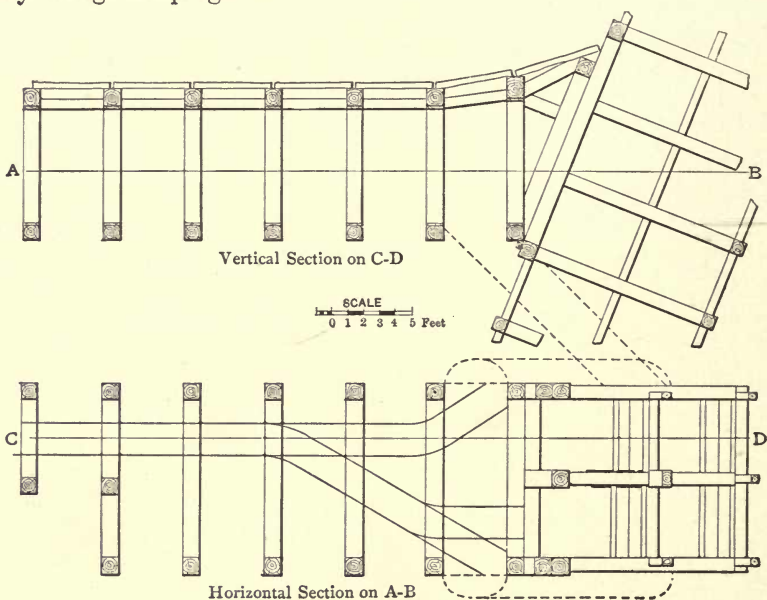
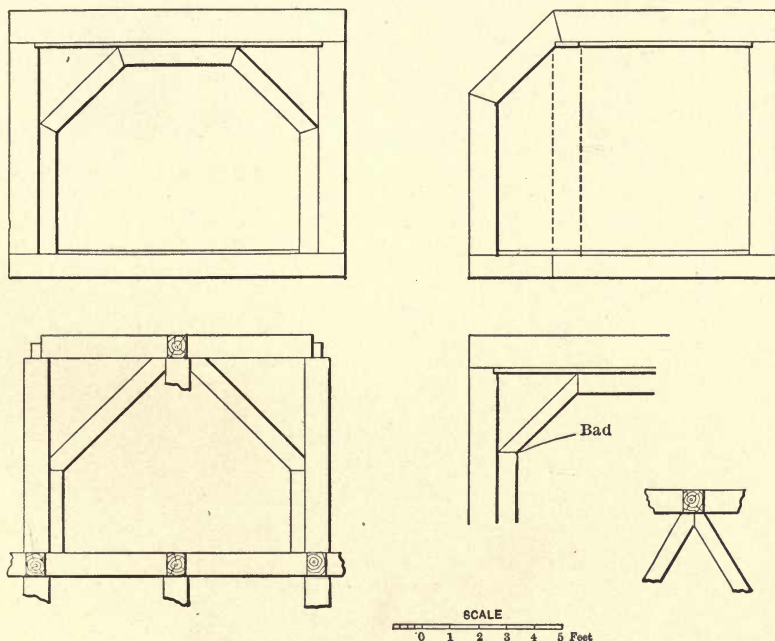

FIG. 126. — FOUR-COMPARTMENT SHAFT SET.

Figure 131 shows the details of the framing of two angle braces put in from one floor up to the tie or cap of the set above, to hold a load concentrated at one point. It is similar to the method shown in Figs. 116 and 122, save that in this case the timber supported runs across the direction of the angle braces. In these cases no sprags or cribbed fillings are necessary to hold the side posts, for the thrust is resisted by the bottom tenons. Figure 128 shows how a tunnel may be widened, say to make room for a double track, without discarding all the timbers in place. This method, however, cannot be used unless the con-

dition of the ground is favorable, for there is the weakness of two joints on that side, instead of one. In good ground, the short side post may even be safely dispensed with, and a hitch can be cut in the foot-wall for the bottom end of the sloping segment.

Slight mention has been made of stull timbering. It is a large and important part of the work, though there are but few details that seem to lend themselves to description. Nevertheless, it calls for as much, if not greater, skill and judgment on



FIGS. 127-131. — DETAILS OF FRAMING.

the part of the timberman to point his stulls and balance the ground to the best advantage, as in any other work. A few features are shown in Figs. 132 and 133. It is always preferable to build the chutes on the foot, not only to get all the steepness of grade possible, but also because it is more convenient for loading cars when the level is run on a bench cut in the foot-wall. It is desirable to run a level thus, in order that it may be left intact when the next stope from below comes through the ore left in the bottom. Sometimes, when the stope is not too high and

the slope is sufficiently steep, no cribbed chute is built at all. In this case the broken rock runs down over the foot-wall in a passage kept open between two rows of stulls, lagged and filled on the outside. Figure 133 shows a cribbed manway built up into the stope alongside of the ore chute.

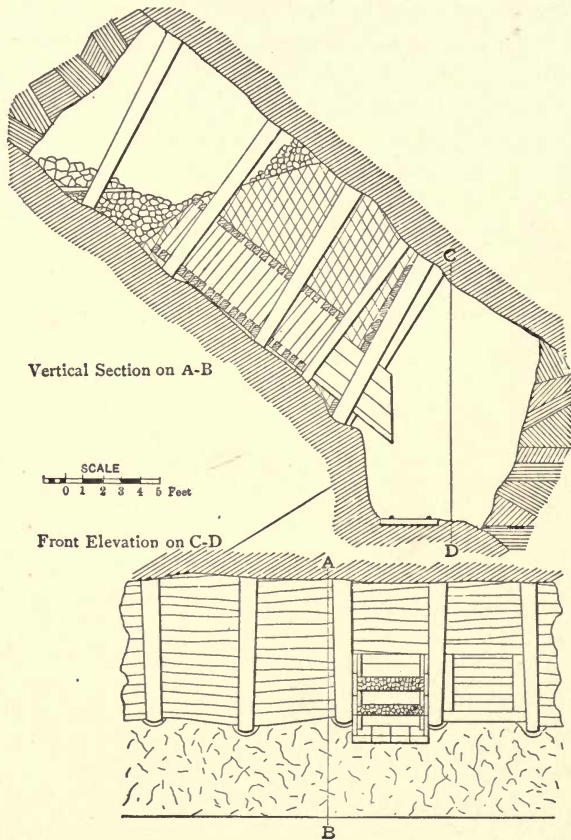

FIGS. 132 AND 133. — STULL STOPE.

Before closing these notes on timbering in the Bunker Hill and Sullivan mines, some figures of costs in regard to square-set timbering will be of interest. Exclusive of the initial cost of material and freight, the total cost of square-set posts, caps, and ties, delivered at the mouth of the mine, is as follows: posts, 12.5c.; caps and ties, 10c. each. These figures include not only

the framing, but also the cost of unloading timber from the cars at the sawmill, the cutting and squaring, and delivery at the mine.

The center dimensions of a standard set are 7 ft. 10 in. by 5x5 ft., giving a contents of 195.75 cu. ft. Assume, for an example, that a set is being put up in ore carrying 20 per cent. galena (about 17.3 per cent. lead) with a heavy quartzite gangue. The specific gravities would be, approximately, galena 7.5, gangue 3.3; and under these conditions it would take about 8.61 cu. ft. of ore in place (unbroken) to make a ton. This would give 22.74 tons for the contents of one square set. There are parts of 12 timbers in each set — four posts, four caps and four ties (see Fig. 123), but only one-fourth of each of these can be charged to a single set. This would be equivalent to one post, one cap and one tie, at a total cost, for outside handling and framing, of 32.5c. per set, or 1.429c. per ton.

Especial attention is called to the fact that all of the accompanying figures are made from timbers actually in place.

In concluding, I wish to express my thanks to Mr. Stanley A. Easton, manager, and to Mr. T. H. Simmonds, superintendent, of the Bunker Hill and Sullivan Mining and Concentrating Company for the assistance they gave me in gathering information.

TIMBERING AT THE CHILLAGOE MINES, QUEENSLAND ¹

BY T. J. GREENWAY

IN working the Chillagoe mines, in northern Queensland, the conditions are such as render necessary the adoption of some method of square-set timbering which will permit of the use of the stunted and twisted local timber without the aid of a saw-mill. After experimenting with various methods of cutting and framing round timber, I devised and adopted the method de-

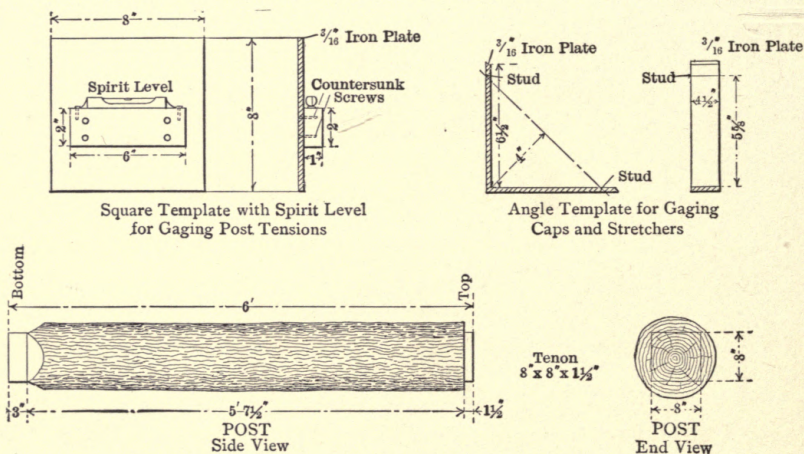

FIGS. 134-137. — TEMPLATES AND POSTS.

scribed hereafter, which has now been in successful use for two years.

The square sets are made up of the usual members, namely, posts, caps and stretchers. The shape of the posts is shown in Figs. 135 and 137, and the shape of the caps and stretchers, which are alike in every respect, is shown in Fig. 138. All are

¹ From *Engineering and Mining Journal*, March 16, 1905, Vol. 79.

cut from rough-hewn logs which are delivered at the various mines by timber-getters in accordance with a specification requiring that the logs shall have a clear minimum length of 6 ft. 6 in., and a minimum diameter of 10 in. The heavier logs are selected for making the posts, and the lighter ones are used for making the caps and stretchers.

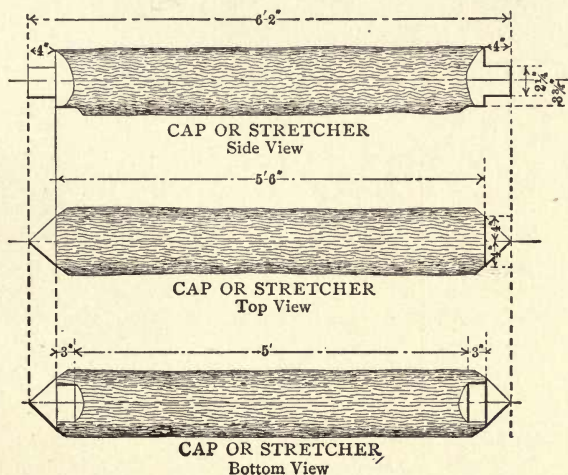

FIG. 138. — CAPS OR STRETCHERS.
10 in. least diameter.

The various set members are cut to the required shapes and dimensions by a simple method of sawing and adzing the logs, accurate measuring, centering, etc., being attained by using the miter box and the angle and square templates shown in Figs. 134, 136, and 139.

A post is made by fixing a selected log in the miter box (by means of wooden wedges) with one rough end projecting out of the squared end of the miter box. This rough end is then cut off flush with the end of the miter box, and the other rough end is cut off to a length determined by the transverse gage cut in the miter box. The post, after having been thus cut square and true to the required length, is taken out of the miter box and firmly fixed in a suitable saw and frame, and the ends are then shaped into square tenons by sawing and adzing them to dimensions which are gaged and squared by means of the square template with its accompanying spirit level.

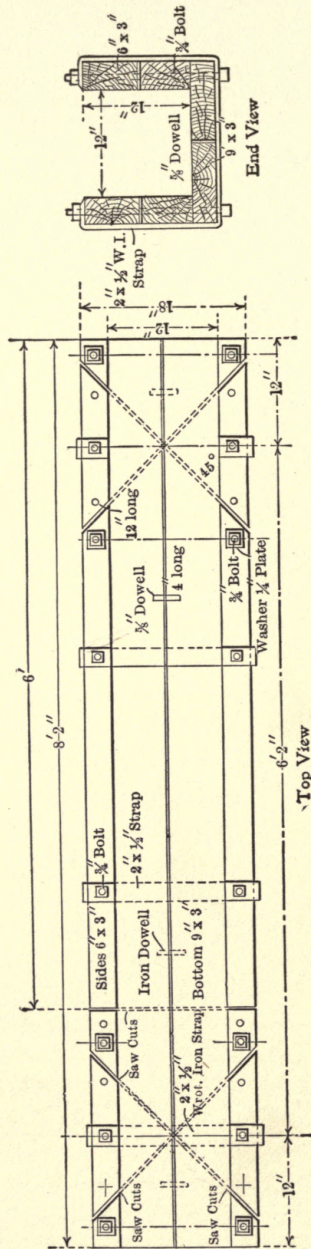

FIG. 139. — MITER BOX.

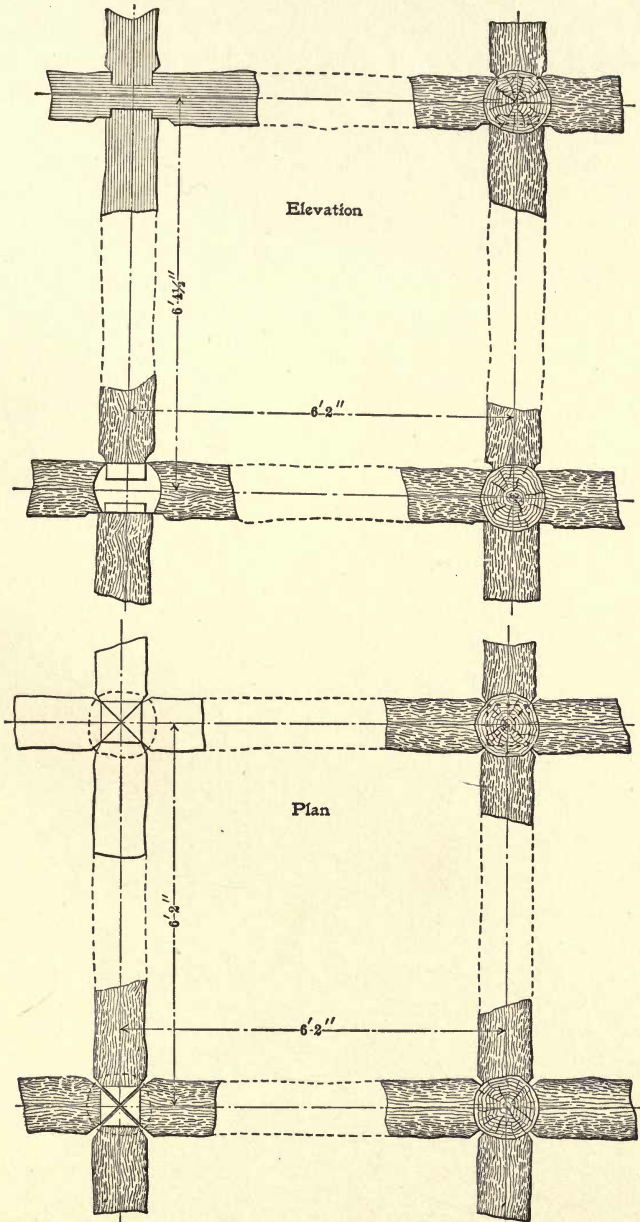

FIG. 140. — METHOD OF FRAMING POSTS, CAPS, AND STRETCHERS.

A cap or stretcher is made by fixing a log in the miter box, and cutting it to the length and shape determined by the miter cuts. It is then removed to a sawing frame, and the beveled ends are shaped into miter tenons by sawing and adzing them to the required dimensions, which are determined by means of the angle template.

The manner of framing the posts, caps and stretchers together underground is clearly shown in Fig. 140.

With this method of cutting and framing, the use of rough log timber for square-set timbering presents no difficulties. As need scarcely be said, such timber is, weight by weight, much cheaper and stronger than sawed timber, and it can be used in remote districts where sawed timber is practically unobtainable. In the Chillagoe district the logs are delivered at the mines at a cost of from 6c. to 8c. per running foot, and the cost of converting them into posts, caps or stretchers is 4c. per running foot.

TIMBERING IN TASMANIA ¹

BY MARK IRELAND

THE orebody being worked at the Mount Rex tin mine, Ben Lomond, Tasmania, is about 100 ft. in length by 70 ft. in width. A face of 15 ft. is stoped over the whole level at one operation, this height standing without any timber.

Double lines of logs, 20 ft. in length, and from 10 in. to 1 ft. thick at the small end, are laid longitudinally, butt to butt, and breaking joint from end to end of the orebody; they are at 10-ft. centers from wall to wall. The starting logs are single for the first 10 ft., and their ends are hitched into the solid rock. These are called "runners," and are the logs which are picked up as the level underneath is worked up. The double layer gives a better chance of picking up. Logs are then laid from the center of the orebody and at right angles to the runners, the ends being hitched into the walls.

A space, 7 ft. wide, is left open right through the center of the orebody, and a similar space through from the cross-cut leading to the shaft. The cross logs are spiked down, 4 ft. apart, to the runners. Decking, of small spars from 3 to 6 in. thick, is then laid down. Timber cribs, or "pig-styes," are next built up, 4 ft. wide, on each side of the open spaces previously referred to, forming a skeleton drive.

The pig-styes are constructed as follows: Two logs are laid parallel, 4 ft. apart, and upon them, in notches at the ends and the middle, three cross sills are laid, two more logs are laid upon them in turn, and so on until 7 ft. high in the clear is obtained. In the spaces between the logs, waste rock is filled in as fast as built. Strong caps, 12- to 14-in. timber, are then laid 4 ft. apart across from pig-stye to pig-stye. Decking is laid over these caps as on the level. Chutes and traveling ways are then built, and

¹ From *Engineering and Mining Journal*, July 22, 1905, Vol. 80.

the level is ready for filling with waste, which is sent down from the surface.

This method is strong, and very cheap as compared with square sets. But little dressing is required, only an ax, saw and auger being required; any rough, but fairly straight, timber will do. An additional advantage is that no blasting, however heavy, can injure it.

INDEX

	PAGE		PAGE
Adit-level.....	4, 36	Cora-Rock Island mine, Butte, Mont.	142
Adits, definition of.....	36	Cost of timbering ...	64, 168, 174
Alinement of inclined-shaft sets	14	Cralk's Colusa mine, Meaderville, Mont.	6
Anaconda mine, Butte, Mont....	50	Crane, W. R.....	144
Angle braces	68, 156	Creeping ground	5
Atlantic mine, Atlantic, Mich..	75, 92	Cribs.....	16, 41, 68, 114, 175
 		Cross-cut, definition of	36
Baltic mine, Baltic, Mich.....	89, 149	 	
Barnum mine, Ishpeming, Mich.	93	Deidesheimer, Philip ..	51, 55, 56, 141
Batcheller, J. H.....	150	Docks	115
Battered tunnel sets	164	Drift, definition of	36
Ben Lomond, Tasmania.....	175	Drift sets	110
Benchs for machines	114	 	
Bingham Cañon	141, 142	Easton, Stanley A.	169
Bingham, Utah	131, 140	Eureka method of framing....	50, 51
Boston and Montana mines, Butte, Mont.	140	 	
Boston Consolidated mine.....	141	False sets.....	7
British Columbia, mining and timbering in	75	Filling, waste	5, 42, 50, 70, 96
Bulkheads.	70, 140, 161	Forepoling	39
*Bunker Hill and Sullivan Co.'s mines	163, 168, 169	Four-compartment shafts.....	31
Burlingame method.....	51	Four-piece set	10, 12, 38
Butte, Mont.	140, 141, 142	Framing, methods of	50
 		Framing rectangular shaft sets..	123
Cactus mine, Newhouse, Utah..	141	 	
Calumet and Hecla mines.....	144	Georgetown, California	56
Campbell, C. St. G.....	105	Girts	38
Cates, Louis S.....	131	Glory-hole method	86, 93
Chillagoe mines, Queensland. ...	170	Greenway, T. J.	170
Chutes, 49, 82, 84, 88, 90, 117, 140,	162	 	
Comstock lode, Virginia City, Nev.	20, 51, 55, 56, 141, 142	Halved framing for shaft sets..	13, 18
Concrete lining	147	Hanging hooks.....	15, 23
Copper, method of mining	89	Haulage ways	97, 99
		Heinze, F. A.	142
		Hematite mine, Ishpeming, Mich.	96

	PAGE		PAGE
Highland Boy mine.....	141, 143	Phoenix, B.C.	85
Homestake mine, Lead, S.D. . .	140	Pig-styes	175
Inclined shafts	10	Pillars	94, 99, 144
stations for.....	13	Plank lagging	12
Ireland, Mark	175	Plumb-bob	14, 24
Iron mining	99, 105	Pole lagging	12
Ishpeming, Mich.	105	Pressure on timbers	5
Knob Hill mine, Phoenix, B.C. .	85	Queen mine, Negaunee, Mich... .	99
Labor in Section 16 mine.....	119	Queensland	170
Ladders	34, 119	Rectangular shaft sets, framing. .	123
Lagging	5, 12, 80, 87, 151	Reinforcing sets	49
Lake Superior, mine timbering		Repairing shafts.....	25
at	144	Rice, Claude T.....	140
Lake Superior Mining Co., Mich.	105	Richmond method	51
Le Roi mine, Rossland, B.C. . .	57, 76	Rossland, B.C., mines ..	55, 56, 67, 70, 76
Lead, S.D.	140	Round timbers.....	7
Leadville mines.....	140	Running ground, timbering in. .	26
Levels, timbering of.....	7, 36, 37	Sanders, W. E.	3, 123
Loose ground, timbering in.	26, 39, 112	Scramming	101
MacDonald, B.	55	Section 16 mine, Ishpeming, Mich.	94, 105
Machines, method of setting up.	113	Shaft sets, locating	22
Michigan	75	rectangular	123
Milling method	86	repairing	25
Mills	116	Shaft station sets	35
Miter box, use of, in framing . .	171	Shaft timbering	108
Mount Rex tin mine, Tasmania	175	Shafts, concrete lining in	147
Mud-sills	78	timbering of	7, 145
Never Sweat mine, Butte, Mont. .	5	timbering in loose ground	26
Newhouse, Samuel.....	141	timbering in running ground	26
Newhouse, Utah.....	141	Sill-floor construction	57, 60
Old Ironsides mine, Phoenix, B.C.	85	Simmonds, T. H.	169
One-compartment shafts	20	Single-compartment shafts.....	10
Ontario mine, Park City, Utah. .	5	Single-piece set.....	37
Open-cut method.....	86	Skip-ways	12
Ophir mine, Nevada	51, 55, 56	Soft Ore Hematite mine, Ish- peming, Mich.	96
Ore chutes.....	49	Sollars	119
Ore-skips	12	Spiling	27, 39
Parlee, N.W.	75, 101, 102	Spragging	38, 79
Penning	41, 45	Square-sawed timber	7
		Square set, limitations of	67

PAGE	PAGE		
Square set, shaft timbers	20	Timbering, levels in loose	
system	106	ground	39
timbering, cost of	65	principles of econ-	
Square sets, in Section 16 mine .	112	omy in	150
in stoping	46	shafts	20, 108, 145
in swelling ground	5	in loose ground	26
reinforcement meth-		in running	
ods	68	ground	26
Square-shoulder framing	6	stations	35
Staging	118	three-compartment	
Stations	35	shafts	29
for inclined shafts	13	two-compartment	
shaft sets for	35	shafts	28
timbering of	7	Tools used in Section 16 mine . .	119
Step method of excavating	63	Top-slicing	98
Straight edge	14, 24, 126	Track laying	76
Stulls	10, 42, 78, 92, 112	Trimountain mine	149
Swelling ground	5	Tunnel	36
Tamarack mines	144, 147	Two-compartment shafts	11, 28
Tasmania	175	Two-piece set	37
Three-compartment shafts	5, 11, 29	Utah Consolidated	141
Three-piece set	10, 37	Vertical shafts	7, 16
Timber and timbering in the		alinement of	24
Coeur d'Alene	150	Wages in Section 16 mine	119
Timber, best kinds to use	150	Walling-up system	89
chutes	84	Waste filling	5, 42, 50, 70, 96
pillars	114	Weight pressure on timbers	5
Timbering, cost of	64, 168	Winzes	83
cribbed shaft	16	Witwatersrand goldfields	31
four-compartment		Working places, timbering	41
shafts	31		
in drifts and stopes	147		





TN

289

S2

390350

cop. 2

Sanders

Mining dept
UNIVERSITY OF CALIFORNIA LIBRARY

