

MODERN
FARM
BUILDINGS

ALFRED HOPKINS

MODERN
FARM BUILDINGS



BUILDINGS OF REINFORCED CONCRETE, A BEAUTIFUL ENVIRONMENT AND A RESTFUL COMPOSITION.
FARM BUILDINGS FOR FRANCIS LYNDE STETSON, ESQ., STERLINGTON, N. Y.

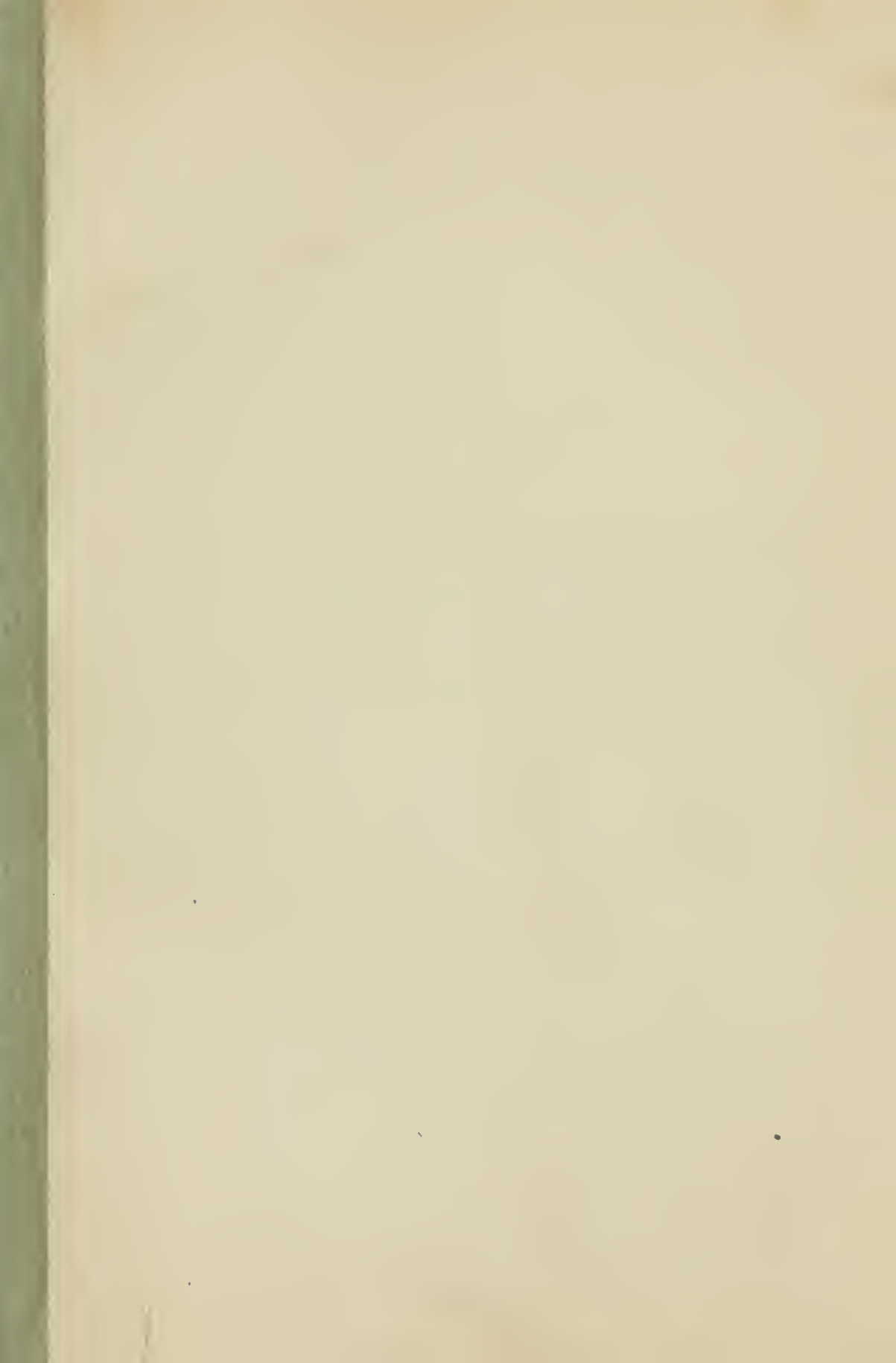

MODERN FARM BUILDINGS

BEING SUGGESTIONS FOR THE MOST APPROVED WAYS
OF DESIGNING THE COW BARN, DAIRY, HORSE
BARN, HAY BARN, SHEEPCOTE, PIGGERY, MANURE
PIT, CHICKEN HOUSE, ROOT CELLAR, ICE HOUSE,
AND OTHER BUILDINGS OF THE FARM GROUP,
ON PRACTICAL, SANITARY AND ARTISTIC LINES

BY

ALFRED HOPKINS

A. A. I. A.

NEW YORK
McBRIDE, NAST & COMPANY

1913

Copyright, 1913, by
MCBRIDE, NAST, & Co.

Published, April, 1913

Architecture &
Urban Planning
Library

N4

8201

H6

TO

EDWARD BURNETT

AN AUTHORITY ON ALL
MATTERS RELATING TO
THE FARM, THIS BOOK
IS INSCRIBED WITH THE
REGARD OF THE AUTHOR

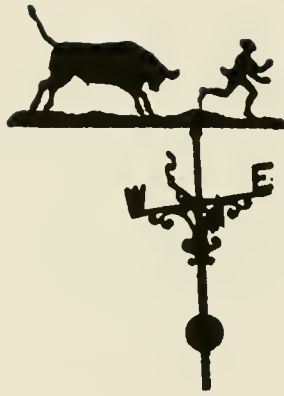

PREFACE

DURING the past twelve years the author has had occasion to design many farm buildings, varying from the smallest establishment to those of considerable extent. Amid all the improved ideas about the care of milk which have developed in the past decade, it has frequently been difficult for the architect to formulate conclusions from the mass of data compiled, and the many opinions expressed by those whose work has led them into the scientific analysis of milk and of milk production. In this search for facts, the author has come into contact with the bacteriologist—impressed by nothing but the thing he feels to be necessary to give a sterile sample of milk; with the enthusiastic herdsman—looking to a record for his cow, with no thought but for the quantity of milk; with the veterinary—who cares neither for milk nor milk production, but is concerned only with the health of the animal; and with the farm superintendent—who, perhaps, takes no special delight in milk production or scientific hygiene for his cattle, but whose first thought is for the arrangement that will permit the work to be done in the easiest possible manner. To reconcile these views is the hope which has inspired the following pages. A vain hope, perhaps, but a real one.

Though the author has been greatly interested in acquiring, in the cause of clean milk, the information here set down—information for the farmer, the herdsman, the dairyman—

P R E F A C E

yet, quite equal to his interest on the practical side, has been his interest in the design of the farm buildings from the standpoint of the architect. He long ago became convinced of the delightful architectural possibilities of the farm barn—possibilities which have not been appreciated, either by his confrères or by the public at large; and this work has been undertaken with the idea of setting forth these possibilities quite as much from the esthetic as from the practical side.

He wishes to acknowledge here his indebtedness to many friends who have helped him in his work: to Mr. S. L. Stewart, for his assistance on the method of milking; indeed the chapter on Administration is virtually a description of the manner in which milk is made at the Brookside Farm; to Mr. James A. Reburn, for many suggestions with regard to the detail of the cow barn; to Mr. Harlo J. Fiske, manager of Skylands Farm, Sterlington, N. Y., for much that is comprised in the chapter on the Chicken House; to the author's friend, Mr. A. Foxton Ferguson, who has proved that friendship many times over by reading through his manuscript and giving to it the benefit of his literary skill; and last, but by no means least, to Francis Lynde Stetson, Esq., who has entrusted to his care the architectural work on the beautiful Skylands Farm, giving him a free hand in the carrying out of every detail, who has been receptive of every thought which would improve any of the buildings in appearance or usefulness, has been patient with the perplexities of building and always helpful in suggestion. It has been a rare privilege to coöperate with him and the author here writes his grateful acknowledgment.

ALFRED HOPKINS

New York City, Sept. 7, 1912.

CONTENTS

CHAPTER	PAGE
I ARTISTIC POSSIBILITIES OF THE FARM BUILDING	15
II THE COW BARN	20
Feed Room	23
Milk Room	27
Location of Cattle	27
Materials	29
Sizes	31
Arrangement of Cattle	32
Cow Stalls	35
Calf Pens	39
Bull Pens	41
Watering and Feeding Troughs	42
Water	45
Floors and Floor Drainage	46
Liquid Manure	49
Plumbing	53
Ventilation	54
Artificial Heat	60
Manure Trolley	61
Bedding	62
Silos	64
Cow Yard	69
Painting	71
Blinds and Flies	72
Doors	73
Windows	75
Utensils	77
III THE DAIRY	79
Milk Receiving Room	81
Milk Room	82
Wash Room	88
Laundry	90
Boiler Room: Live Steam	92
Plans of Dairies	93
Heating and Ventilating of the Dairy	97
IV ADMINISTRATION	99
Milking Machines	107
Vacuum Cleaner	108
V OTHER BUILDINGS OF THE FARM GROUP	110
The Hay Barn	110

CONTENTS

CHAPTER	PAGE
The Farm Stables	114
Wagon Room	114
Harness Room	114
Horse Stable	115
Stalls	118
Feed Room	121
Sheds	121
Machinery Room and Tool Room	122
Leaders	123
Hardware	123
VI PLANS OF FARM BARNS	127
At Oyster Bay, L. I.	127
At Rhinebeck, N. Y.	130
At Scarsboro, N. Y.	132
At Westbury, L. I.	135
At Greenwich, Conn.	138
At Sterlington, N. Y.	140
At Islip, L. I.	143
At Morristown, N. J.	146
At Woodbury Falls, N. Y.	147
At Brookville, L. I.	149
At Oyster Bay, L. I.	151
At North Easton, Mass.	153
At New Boston, N. H.	155
The Briarcliff Farm, White Plains, N. Y.	157
Proposed Farm Buildings at Port Chester, N. Y.	159
VII THE SMALLER PROBLEM	165
VIII THE GARAGE	170
The Independent Garage	173
IX OTHER BUILDINGS OF THE FARM	180
Chicken Houses	180
Poultry Bibliography	189
Sheepfold	190
Manure Pit and Piggery	195
Root Cellar	200
Ice House	203
Corn Crib	205

THE ILLUSTRATIONS

	<i>Frontispiece</i>
	FACING PAGE
Farm buildings for Francis Lynde Stetson, Esq., Sterlington, N. Y.	15
Water tower for Mortimer L. Schiff, Esq., Oyster Bay, L. I.	15
Coach stable and coachman's cottage for Francis Lynde Stetson, Esq., Sterlington, N. Y.	16
Farm buildings for H. M. Tilford, Esq., Munroe, N. Y.	19
Tool house, Skylands Farm, Sterlington, N. Y.	28
Old farm buildings on Long Island	28
Interior of a commercial cow barn	32
Cow barn interior, showing steel stanchions	32
Interior of cow barn with pipe stalls arranged for the tie	36
Bull yard and exerciser	41
Continuous and divided feeding-troughs	42
Manure trolley and carrier	61
Sliding hay door near the ridge	76
Cow barn windows	76
A corner of the dairy for Mortimer L. Schiff, Esq., Oyster Bay, L. I.	79
Concrete cooling-vat in milk room	82
Galvanized-iron can for ice-water	82
Milk cooler for commercial plant and bottling-table	86
Milk cooler and bottle filler for the small plant	86
The dairy wash sink	88
Two kinds of pipe-rack dairy tables	88
High-pressure sterilizer	90
Laundry machine for the dairy	90
An ice house in the woods	102
Hosing out the cow barn	102
Two methods of framing the hay barn	111
The farm shed in the group for F. G. Bourne, Esq., Oakdale, L. I.	118
The West Point horse stall	118
Farm buildings for Tracy Dows, Esq., Rhinebeck, N. Y.	127
Farm buildings for Louis C. Tiffany, Esq., Oyster Bay, L. I.	128
Farm buildings for Tracy Dows, Esq., Rhinebeck, N. Y.	130

THE ILLUSTRATIONS

	FACING PAGE
Farm buildings for James Speyer, Esq., Scarboro, N. Y.	132
Drinking-trough and pergola in the farm group for James Speyer, Esq., Scarboro, N. Y.	134
Farm buildings for Charles Steele, Esq., Westbury, L. I.	136
Farm buildings for H. F. Fisher, Esq., Greenwich, Conn.	138
Farm buildings for Francis Lynde Stetson, Esq., Sterlington, N. Y.	140
Farm buildings for S. T. Peters, Esq., Islip, L. I.	143
The dairy in the farm group for S. T. Peters, Esq., Islip, L. I.	144
Farm buildings for Charles E. Rushmore, Esq., Woodbury Falls, N. Y.	146
Farm buildings for O. H. Kahn, Esq., Morristown, N. J.	146
Farm buildings for J. E. Davis, Esq., Brookville, L. I.	149
Farm buildings for J. E. Davis, Esq., Brookville, L. I.	150
Details in the farm group for Mortimer L. Schiff, Esq., Oyster Bay, L. I.	152
Farm buildings for F. L. Ames, Esq., North Easton, Mass.	154
Farm barns for the J. Reed Whipple Co., New Boston, N. H.	156
Proposed farm buildings for the late Hugh J. Chisolm, Esq., Portchester, N. Y.	159
Planting about the dairy in the farm group for Mortimer L. Schiff, Esq., Oyster Bay, L. I.	164
Temporary garage for Clifford V. Brokaw, Esq., Glen Cove, L. I.	170
Stable and garage for C. R. Agnew, Esq., Armonk, N. Y.	172
Piggery for S. T. Peters, Esq., Islip, L. I.	174
Garage for S. T. Peters, Esq., Islip, L. I.	174
Chicken houses for Francis Lynde Stetson, Esq., Sterlington, N. Y.	180
Colony houses permanently located	182
Interior of brooder house	182
Covered manure pit, Skylands Farm, Sterlington, N. Y.	188
Interior of a chicken house	188
Sheepfold and shepherd's quarters for Francis Lynde Stetson, Esq., Ster- lington, N. Y.	190
Interior of sheepfold, Skylands Farm, Sterlington, N. Y.	192
The piggery, Skylands Farm, Sterlington, N. Y.	195
Corn crib in the farm group for Clifford V. Brokaw, Esq., Glen Cove, L. I.	205
Two types of corn crib	206

MODERN
FARM BUILDINGS



AN ATTRACTIVE LOCATION FOR SUCH A STRUCTURE. WATER TOWER FOR MORTIMER L. SCHIFF, ESQ., OYSTER BAY, L. I.

MODERN FARM BUILDINGS

CHAPTER I

ARTISTIC POSSIBILITIES OF THE FARM BUILDING

THE country has always attracted man as a place in which to rear his habitation and no matter how complex are his urban interests there is in the human heart a lurking desire sooner or later to revert to the soil. The effort of the architect to make beautiful the country home furnishes many interesting examples all over the world, though the most famous of these are to be found in Italy. Here the art of the architect finds its proper complement in the art of the gardener, and under the beautiful Italian skies the villa and its gardens reached a perfect development. In England the country estate has achieved a rare degree of importance, but while more acreage is brought under immediate cultivation, the result is at times lacking in charm when the more serious Northern effort is compared with the lightness and the grace of the South. While the Italian and the English phases of country life are captivating and have been the source of almost all our inspiration, yet it must be left to our own architects to develop and perfect an American ideal of the country home; and never were opportunities more golden.

As the home needs the adornment of shrubs and trees and flowers, so do the fields and meadows require the amiable presence of animals to complete the picture; and indeed it may

be argued that they and not man are the real tenants of the soil, and to house them properly and fittingly is a problem that no artist need despise. The various buildings necessary for their several uses are capable of such an infinite variety of groupings, that the requirements of the farm would seem to offer more scope to the architect than do the problems of the house. There are the tall towers for water or ensilage; the long, low creeping sheds for the storage of wood, farm implements and machinery; and the huge protecting and dominating structures required for the proper housing of the hay, grain and straw. With these buildings in effective combination and appropriately placed among the fields, the picture of the farm can be made so pleasing, and the idea of going back to Nature as the source of all sustenance so ingratiating, that it would be possible to build up an effective philosophy on the principle that the architecture of the home should be made to resemble the architecture of the farm, rather than the other way about. While the various examples of farm barns, which are to follow, may not at all times substantiate this view, yet we trust that some of these may be found of sufficient interest to impress upon the man with landed estates that in his farm buildings he has delightful architectural possibilities which should not be ignored or entrusted to incompetent hands.

As the buildings are capable of such variety of architectural expression, they not only demand a proper and adequate environment, but they are entitled to it by every reason, practical as well as artistic. They should not be shunted off into an out-of-the-way corner or placed at a disadvantage because of a mistaken idea that farm buildings are not worthy of a picturesque or an important position. Each one of the centers of interest on an estate has its own individuality which



RAMBLING ROOF LINES



ROUGH FIELD STONE AND HEWN TIMBERS. COACH STABLE AND
COACHMAN'S COTTAGE FOR FRANCIS LYNDE STETSON, ESQ.,
STERLINGTON, N. Y.

must be respected. The house place with its hospitality of garden, lawn or grove; the farmstead; the stabling and garage; the deer park; the lakes or watercourses with their verdured shores—each contributes to the fascination of the whole; but since it is in human nature to become fatigued with what is continually before the view, it is well to give to these various centers a certain seclusion of their own. This would suggest the choosing of a site for the farm barns well away from the immediate haunts of the home, and where they may be visited only by a pilgrimage through pleasant fields and lanes.

There is no doubt that an ideal situation is to be found on the top of a hill, where the long, low buildings can be thrown into prominence against the background of the sky. Here would be an inspiration for the designer to bring out the full effectiveness of his sky line, always a splendid possibility and one to which the diversities of the farm group so readily lend themselves. While the crest of a hill is certain to offer an effective treatment, yet a position half way down a long southern slope also provides an admirable setting, desirable in some climates and localities for the protection it gives in winter, where the force of the north wind may be tempered by the high-lying land in that direction. No builder who enters into the practical consideration of his problem will choose a site where the waters from the adjacent land cannot be easily turned aside, nor one where the drainage from the buildings themselves cannot be readily conducted away.

To speculate upon the architectural type of the structure is a fascinating occupation for the artist, but all esthetic discussion of the farm barn finally resolves itself into the view

that the keynote of the whole scheme should be simplicity of construction and detail, and that all the well-worn motives of architectural ornament should be abandoned; and this view obtains not only in the outlines of the exterior, but in the interior plan of the structure as well. The author long ago gave up the idea of formulating a plan for the farm barn along the generally accepted lines of architectural symmetry. This scheme of design is entirely too rigid to suit the problem either artistically or practically, and a more flexible manner should be chosen. The special uses of the various portions of the buildings are so different that, for example, it is difficult to reproduce in strict architectural symmetry the quarters for the horses in a wing that shall be identical in appearance with the quarters for the cows, without sacrificing very considerably the practical requirements of either one wing or the other. The strictly formal plan and elevation which the architect has devised as fitting for the stately palace and the great garden, seems entirely out of place when he comes to the humbler problem of the farm. Here the rambling, happy-go-lucky type of plan will yield fully as much in artistic value and will hamper the architect less in his effort to combine the practical with the beautiful.

The local materials, whatever they are, will be the least expensive in cost and the most suitable in appearance. Nothing could be more fitting than to build the farm barn in rough stone or of rived cypress shingles—or of stone and shingles in combination. Stucco presents an admirable surface for this character of structure; the vines grow well on it, and the moving shadows from the trees give it a continual variation of light and shade which always lends a charm to its surface. Brick may be used with equal propriety and effect and in the



HERE THE DAIRY AND WAGON YARD ARE NEARLY FOUR FEET LOWER THAN THE FLOOR OF THE HAY BARN. FARM BUILDINGS FOR H. M. TILFORD, ESQ., MUNROE, N. Y.

old-fashioned weatherboarding of the farmer's barn there are still hidden possibilities of design that only await discovery by the artist who shall know how to use them.

The irregularities of site frequently offer equally interesting opportunities; for when the buildings cover a considerable ground area, or when, as often occurs in rolling districts, a level site of sufficient extent is not available, the architect may then greatly increase the interest of his work by placing his buildings at different levels, thereby letting his structure adapt itself more to the conformation of the ground. This is a phase of country building which he has been slow to appreciate, for his habitual custom is to level off all inequalities of site and construct a plain or plateau on which to rear his building. It is, therefore, well for him to proceed with caution if it becomes necessary to lay violent hands upon Nature's outlines, and not to mar her beauty by unnecessary cuts, fills, or embankments, nor with roads of too great a prominence, for even these should be carefully contrived and screened with plants and trees, so as not to make an obtrusive scar upon the face of the landscape.

Nothing is more helpful to the architect's work than the soft influence of vines and trees and shrubs, and the consideration of these should not be neglected, for nowhere are they more appropriate than in the environment of the farm building, where their presence will soften the hard, constructional lines of the builder. The farm barn should have, therefore, every benefit which the growing plant and vine can yield and nestle quietly and unobtrusively where it will give to the eye the sense of shelter and of animal comfort and quiet.

CHAPTER II

THE COW BARN

WE will now leave, somewhat reluctantly, the architectural possibilities of the farm barn, and take up what must always come first in the consideration of any building project—its practical requirements.

It would seem proper to commence the discussion of the modern farm building with the cow barn, which is the most important building in the group; we will then proceed to a consideration of the dairy, with which it is intimately connected, and finally, we shall review the uses to which both are put, so far as such uses influence the general plan of the building.

With the idea of the purity of the milk constantly in mind, it must be remembered that the sources of its contamination are now no longer to be found in sewage, manure and the filth that used to prevail at the farm barn twenty or thirty years ago. Then nobody thought it necessary to pay any special attention to the sanitary condition of the cow, and the most unsanitary conditions in the matter of her care and environment prevailed generally. The milk methods of that time have been strikingly brought out by Dr. Wm. T. Sedgwick in his "Principles of Sanitary Science and the Public Health": "It should never be forgotten that if water were to be drawn, as milk is, from the body of a cow standing in a stable, by the hands of workmen of questionable cleanliness, and then stood and transported over long distances in im-

perfectly cleaned, closed cans, being further manipulated more or less, and finally left at the doors at an uncertain hour of the day, few would care to drink it, because its pollution and staleness would be obvious. . . . It is clear," he goes on to say, "that milk requires and deserves more careful treatment than water, for it is more valuable, more trusted, and more readily falsified and decomposed."

Now that the habit and knowledge of cleanliness is more general, it has been observed that the infection of milk is not

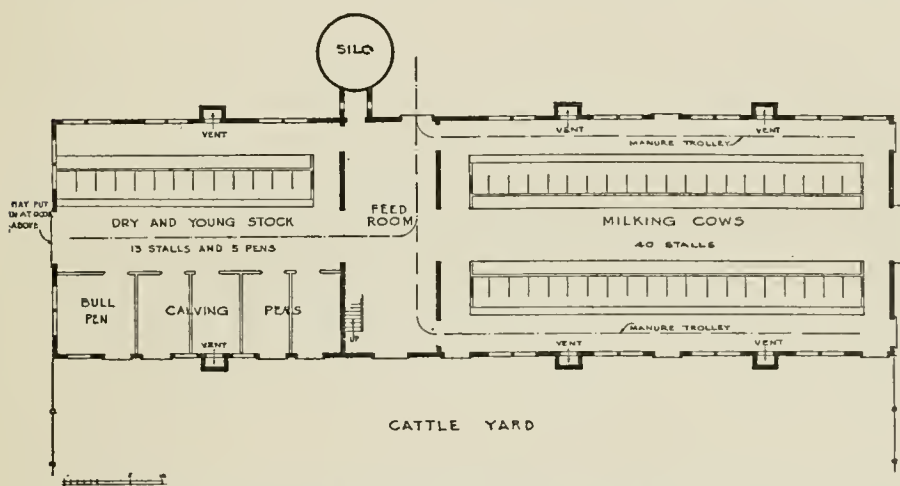

FIG. 1—PLAN SHOWING SIMPLEST POSSIBLE ARRANGEMENT OF COW BARN FOR YOUNG STOCK AND MILKING COWS—FEED BEING STORED OVER YOUNG STOCK

so much due to the virulent pathogenic germ found in filthy and unsanitary surroundings, as to the bacteria on the dust *in the stable*, and especially the dust of the feed, grain and hay. For this reason it is desirable to place the milking cows as far as possible from the storage of hay, bedding and the like, which brings up at once the question as to whether it is advisable at all to store hay over the animals, although long custom has established that usage. Under certain conditions

—especially in cases where the floor between the cows and the loft above is fireproof, and where there is no communication between the storage of hay above and the cows beneath—it would be possible to put the hay over the animals without great damage to the milk. Fig. 1 shows a plan where the storage of hay is above the animals, drawn down into a feed room between the milking cows and the young stock, but even here the hay loft should be filled from the back and the bulk of the hay stored above the young stock and feed room, in preference to using the space over the milking cows. The great objection to hay above the milking cows is that at haying time so much dust is caused in filling the lofts that the making of good milk during that period is impossible, even with all the windows of the milking barn closed. For that reason the hay is best put into the barn at the rear of the building, and as far removed from the quarters of the milking cow as possible. This is the simplest type of barn for the man who wants to take care of his stock at a minimum cost of building and labor, and there is no reason why, with proper care, milk should not be made in such a structure which would answer every requirement of clean milk. In the author's practice, however, he has always endeavored to carry out the idea which aims at separating entirely the storage of the feed and hay from the housing of the animals, not only on account of the contamination of the milk by the dust in the feed, but equally on account of the contamination of the feed from the odors of the stable. Man has only to think how loathsome his own food would become if tainted by the fumes of sewage, to realize how greatly the quality and value of the fodder for his animals would be lessened by a similar contamination. If hay is ever stored above the live stock, par-

ticular care should be taken that none of the fumes of the stable can reach it. The vent ducts may go through the hay loft, but they should be carefully papered and sheathed tight on both sides of the studding, and on no account should they open into the loft for any reason whatever. The custom of throwing hay down into the stable below through the vent duct must not be tolerated.

FEED ROOM.—From a scientific as well as a practical point of view, the feed room is just as necessary for the care of the animal as the pantry is to the service in the human household. It is located between the hay barn and the cows, and is the place into which the feed is drawn, and there cut and mixed. The door of the feed room should always be closed when feed is being prepared, or when dust from it is liable to get into the cow barn, no matter whether the cows are being milked or not. The feed room should be a place solely for the preparation of the feed, and not for the storage of it. Hay is cared for in the hay barn and, in fact, the general storage of meal, grain, etc., is best effected above the feed room and not in it. In fact a very good system of feeding is to mix the feed either above or away from the feed room, and so keep the dust occasioned by mixing out of the feed room entirely. Grain is almost invariably sold in bags, even when bought in carload lots, and the proper storage of feed is to keep it in the bags; feed keeps fresher in bags than when stored in bulk, and consequently the feed bins need not be any larger than is necessary to hold a week's supply. When empty they are refilled from the bags of stored meal. Feed bins are invariably lined with metal, the four sides as well as the covers; and if projected down into the room below, as shown by Fig. 2, the feed will not clog up and cake in the

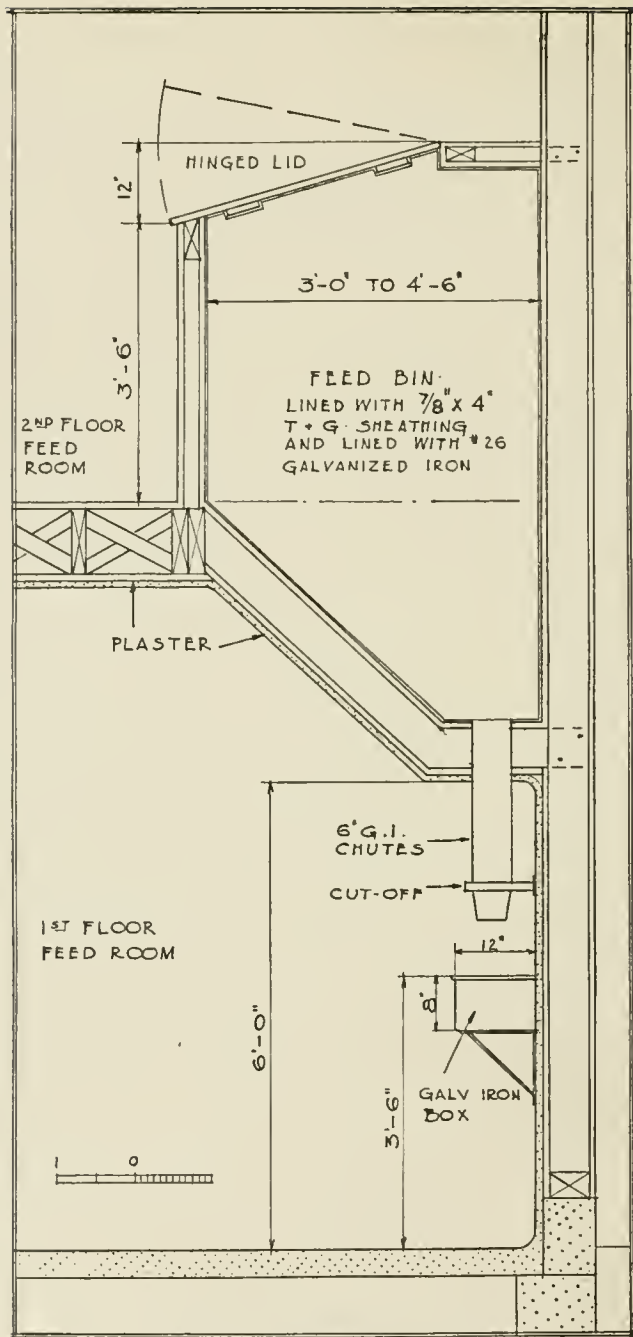

FIG. 2—SECTION OF FEED BIN
[24]

bottom of the bins, but will run freely through the chutes. Four compartments are desirable, though three are usually sufficient—two small ones and one or two larger ones, as the young stock, dry stock, and milking cows all require different rations.

The feeding cart, as well as all utensils for mixing the feed should be kept scrupulously clean. Water must be had at a

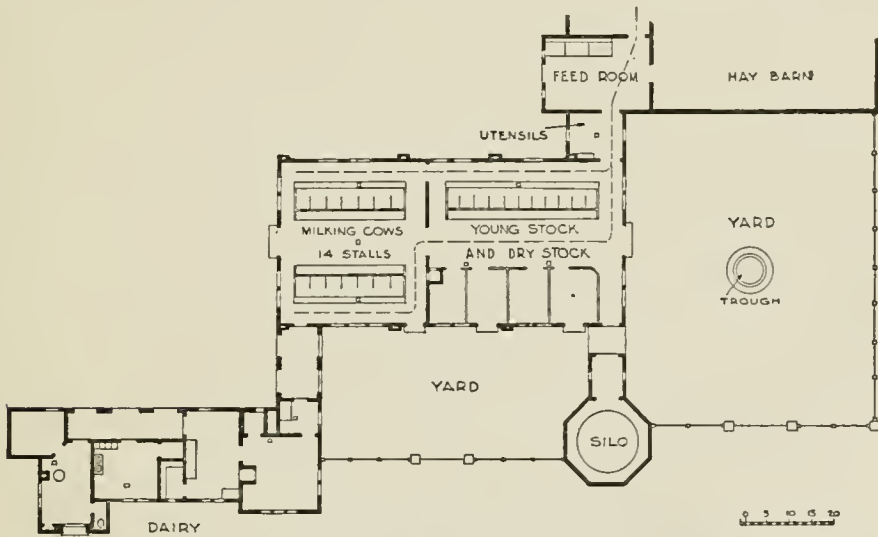

FIG. 3—A TYPICAL PLAN FOR HOUSING A HERD OF FOURTEEN MILKING COWS, FOUR DRY STOCK, SEVEN YOUNG STOCK AND A BULL

place convenient for cleaning—preferably both steam and water. In the plan illustrated by Fig. 3 a separate small room has been provided with steam connections, not only for the keeping but for the special cleaning of the feed carts, manure carriers and all the utensils of the cow stable.

It is desirable, especially in large plans, that the feed room should have an outside door, so located that a loaded wagon may be driven through it easily without backing. There is no objection to backing out empty; but all places of storage

should certainly be located where they can be reached without it being necessary to back when loaded.

Root cellars are frequently placed below the feed room but since ensilage has come into such favor with dairymen, the use of roots in feeding is less general than it was, and the root cellar is now kept more for the storage of vegetables and fruits, when it is best located away from the farm barn entirely. Root cellars under feed room and under portions of the hay barn are very liable to freeze in extremely cold weather and, in order to avoid this, it is well to have a chimney whose flue, not less than 12x16 in., can be used for ventilation and also for a stove. Ventilation in the root cellar is essential and this must be so arranged as to allow the air to circulate through every part of it.

Access from the feed room to the root cellar below or to

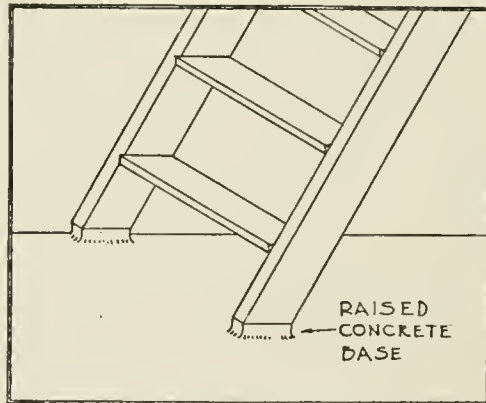

FIG. 4—SHOWING SANITARY COVE FORMED OF CONCRETE AT FOOT OF LADDER STAIRS

storage above should always be had by steps and not by ladder. It is frequently necessary for the man to carry something above or below which cannot be done handily on a ladder. Fig. 4 shows the usual type of such steps, with the bottom

of the stringer raised upon a concrete base to avoid the sharp angle of the stringer with the floor.

MILK ROOM.—In the larger establishment a milk room at the barn is desirable, where should be placed the usual twenty-quart can into which the milk from the milkers' pails is poured. Here the scales and records of each cow are kept, and the basins are placed in which the men wash their hands after each milking. This milk room is entered by double-swinging doors which must be opened by the milker pushing them with his elbows and not with his hands. If special care is required the milk room may be separated from the cow barn by two doors. For the smaller problem an alcove may be formed at the cow barn, where a wash-basin and towel are placed. A milk room may be placed at the end of a passageway and adjoin the dairy, all of which arrangements may be seen in subsequent plans. The real reason for this room is to provide a place that may be kept free from flies, odors and dust. If the cow barn is such a place (and it should be) then the necessity for a milk room diminishes and, as will be seen from some of the plans, it has occasionally been omitted, in the hope that ideal conditions at the cow barn may prevail and that the milk room may not be required. These ideals however, have seldom been realized.

LOCATION OF CATTLE.—The milking cows must always be kept separate from the young stock and the dry cows, and to avoid all confusion as to what class of cattle is meant, cows giving milk will be designated as milking cows, the others as dry stock or young stock. A greater degree of cleanliness is necessary for the milking cows, and consequently they should be in an apartment by themselves, away from the dry stock, young stock and all other animals. This

separation is so important that it cannot be insisted upon too strongly.

The best exposure for the cow barn is undoubtedly with its long axis northwest and southeast; this places the building so that it will receive the greatest benefit from the cooling summer breezes and the warming winter sun; and the windows should be large and numerous so as to be effective in both seasons.¹ The separate wing for the cows which gives air on three, if not four, sides is a much better plan than to quarter them within a building which limits their exposure to only one or two sides. Care should also be taken so to place other structures of the farm group that they will not deprive the animals, whether cows or horses, of the sun and air which they need. Fig. 3 illustrates a typical plan for housing a herd of fourteen milking cows, four dry stock, seven young stock and a bull. The necessary calf and calving pens are provided. These latter are interchangeable and are used for the cow to have her calf in, also for the rearing of the young animal. It is possible, and in fact desirable, in a herd of this size, to accommodate all the cattle—young stock, dry stock and milking cows—under one roof. One compartment has been provided for the milking cows and another for the young stock, dry stock and the bull; connecting with the former is the covered passage to the dairy; with the latter is the feed room with a place already noted for the cleaning and keeping of the va-

¹ Those who wish to go more carefully into the placing of a building with regard to its exposure, will be much interested in a little volume, "The Orientation of Buildings or Planning for Sunlight," by William Atkinson—John Wiley & Sons, New York, 1912. Mr. Atkinson points out very clearly the importance of the orientation of the hospital and shows how the plan may be devised so that no part of the adjoining ground need be in complete shadow cast by the walls of the building. Such an arrangement of plan is doubly desirable for the farm building, and for the commercial building where artistic considerations are ignored, this point should never be neglected.



TOOL HOUSE IN THE WOODS, SKYLANDS FARM, STERLINGTON, N. Y.



OLD FARM BUILDINGS ON LONG ISLAND—ARTISTIC, BUT UNSANITARY

rious utensils of the cow barn—pitchforks, shovels, brooms, brushes, curry-combs, etc. It is always better to locate the young stock between the milking cows and the feed room, as the milking cows should not be disturbed by traffic through their quarters into the young stock barn.

In planning for a given number of animals, it is necessary to know approximately what ratio exists between the milking cows, dry stock and young stock, so that the proper accommodations for each may be provided. This ratio is variable according to conditions. The owner may not desire to raise his young stock, though in this case he loses one of the most attractive and interesting occupations of the farm; but if he does, and the natural conditions prevail, from thirty per cent. to fifty per cent. of the entire herd will be young stock or dry stock. Or, if he starts with a number of milking cows, accommodations for from fifty per cent. to seventy-five per cent. of that number will be required for his young stock and dry stock. There should be one calf pen for every four or five milking cows in small herds, and this proportion may be reduced to one calf pen for every ten cows in the larger herds. *

MATERIALS.—The material for the interior surface of the cow barn is selected with a view toward the elimination of all wood. Even in a wooden structure the interior walls can be entirely covered with non-absorbent materials, which render it possible to make a wooden building just as sanitary as one of masonry. To get this result it is necessary that the walls to the height of 3 ft., 8 in. or 4 ft. above the floor (or to the under side of the windowsills) be plastered in Portland cement, using the same mixture as for the top coating of the concrete floor, and forming a cement dado all around the building. This cement dado, as well as the plastering

above, is best put on galvanized iron lath. Above this point the walls and ceilings are plastered in the usual manner but finished with some hard substance, such as Keene's cement. To reduce cost slightly the ordinary hard-finish plastering on wooden lath above the cement dado gives fairly satisfactory results, and it is well to observe here that plastering of the simplest kind is very much better than the old-fashioned method of sheathing with wood and varnishing the interior of stables. To this method there is every objection—the woodwork is absorbent in spite of the varnish, the varnish deteriorates in a very short time, it makes a dark stable, and is more expensive than the plastering. All offsets in the plastering should be carefully avoided and 3-in. coves run at all interior angles, while all exterior angles should be rounded. Where the cement dado and the white plastering on the side walls come together it is never desirable to make a joint; let the mason finish the two materials as smoothly together as possible. At the connection a 4-in. stripe may be painted, which, however, must be done in some damp-resisting paint, as the ordinary oil paint would be discolored by the action of the cement.

It is possible to avoid all wood in the interior of the cow barn, except in the doors and window sash. In some instances, where perfection has been sought, iron window frames and doors have been installed, but they are much more expensive, being harder to set and to repair, and rather more likely than wood to need repair, so that wooden doors and window sash seem to answer all requirements, even from the strictest hygienic standpoint. The doors, however, are better if sheathed smooth on the inside than paneled in the ordinary fashion. The idea of doing away with all dust-catching pro-

jections should be carried out even to the very smallest detail. This point cannot be insisted on too strongly, for it is astonishing how the dust from the hay will collect wherever it can find lodgment; for this reason even the muntins in the win-

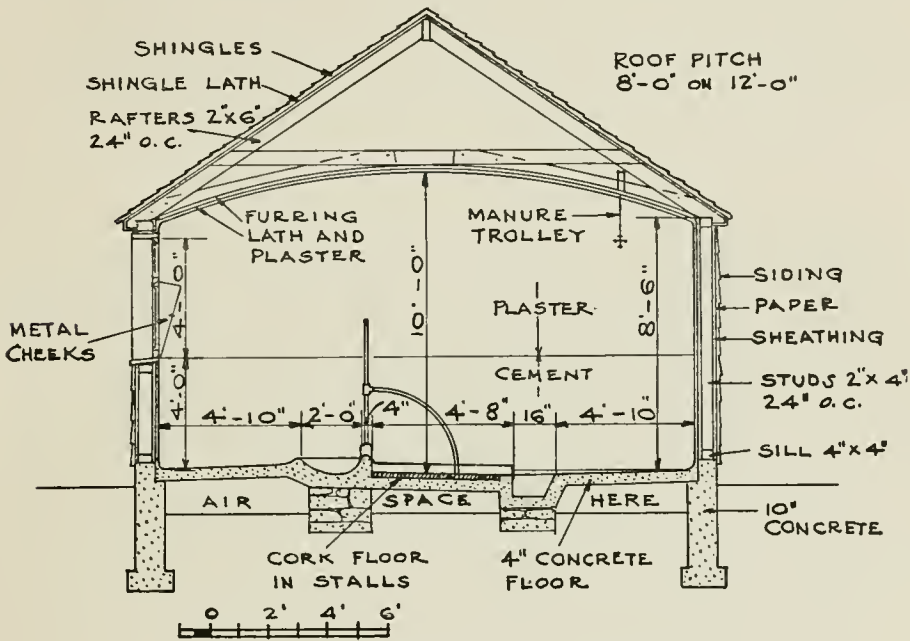

FIG. 5.—SECTION THROUGH A COW BARN 18 FT. WIDE

dow sash are designed without moldings, while all horizontal muntins are best omitted entirely.

SIZES.—The various State legislatures in the United States require that cow stables shall allow a volume of from five hundred to eight hundred cubic feet of air per cow, but an average between these will be all that is necessary. This, reduced to the simplest formula, will work out about as follows:—

Cow stables for double rows of cows should have a minimum

width of 36 ft.; for a single row of cows, a minimum width of 18 ft. The height of the ceiling can vary from 8 ft. to 10 ft.; in colder climates the lesser dimension, and in warmer the greater one. Cow stables for double rows of cows have been made as wide as 42 ft., but this is too wide; it makes a cold stable in winter and the extra width involves a needless expense. A width of 36 ft. is sufficient for stables where the

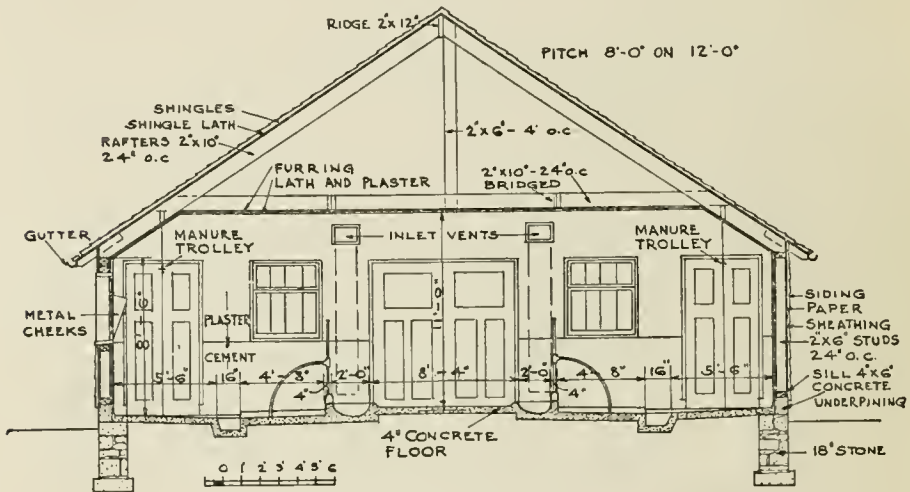

FIG. 6.—SECTION THROUGH A COW BARN 36 FT. WIDE

2-ft. trough is used, and 38 ft. or 39 ft. where the wide trough is contemplated. Figs. 5 and 6 will show the exact dimensions of passageways, troughs, gutters, etc., in an 18-ft. and a 36-ft. cow stable. It is always desirable to have a passageway entirely around the cows, though in smaller farm buildings the passageway may be omitted at one end.

ARRANGEMENT OF CATTLE.—For double rows of cattle it is generally conceded that placing them face to face is the best, as it also is the most sightly arrangement. It has the advantage of simplifying the process of feeding; it brings



INTERIOR OF A COMMERCIAL COW BARN



COW BARN INTERIOR, SHOWING STEEL STANCHIONS AND ALSO AN EXCELLENT TYPE OF THE FEEDING-TROUGH—LOW AND BROAD

the gutters next to the windows, where the sunshine will sterilize them; and it gives the milker more light for his work—a decided advantage on dull days.

The worst feature of placing the cows with their tails together, is that the manure dropping in one gutter will sometimes splash across an 8-ft. passageway and on to the udders of the cattle opposite. It can readily be seen that this is undesirable and especially so at the actual time of milking, when not only the milker and his pail may be fouled, but the milk itself. Though this perhaps may be of rare occurrence, the bare possibility of such a thing should be effectually guarded against. It is frequently convenient, however, to put the young stock or dry stock, tails together, as will be shown later; this arrangement generally simplifies the tracking for the manure trolley. The passageway between the cows, when they are placed head to head, should always be kept wide enough to prevent one cow from breathing in the face of the one opposite. On a cold winter's morning an occasional sigh or cough will send the frosted breath almost across an 8-ft. passageway, so that the distance between the troughs should never be less than this. Also, in order not to pocket the air in front of the cattle, the front of the feeding-trough should be low. High feeding-troughs or mangers are undesirable, as they do not afford an unrestricted circulation of air at the animal's head.

The principal advantage claimed by those who prefer the cows facing the windows, is that they get fresher air in this position. Any stable, however, of 36 ft. to 40 ft. in width can be ventilated so that the air in the center will be just as fresh as the air at the outside. Very few stables have been built in America of greater width than that required for two

rows of cows, and such stables are not to be tolerated, for the very reason that the building becomes so wide that it is impossible to ventilate it at the center. Such a structure too is usually so full of posts, girders and the framing necessary for the center skylights, that it is out of the question ever to keep it in the condition of cleanliness demanded by modern milk methods. It is practicable to extend the 36-ft. barn in length, so that one building may contain a hundred, or even two hundred cows, but this is desirable only in the large herds of four, five or six hundred animals. It is generally better to make the unit a smaller one and not to have more than fifty or sixty cows in one building. Nor is it ever well to have more than twenty cows in a row, without a passageway between them, and there are herdsmen who have felt that even this is too great a number. But if we consider that the work in the cow barn is always down the length of the stable and not across the width of it, we shall conclude that a 3-ft. passageway between every twenty or twenty-five cows is quite sufficient.

A certain advantage was thought to be gained by making a wide passageway through the width of the stable so that a wagonload of green fodder could be driven into the building and unloaded in the central passageway between the cows. The advantage, however, of the arrangement is questionable, since the position of the manure track, as it hangs from the ceiling, necessitates a low load, and in any case the driving in of horses causes commotion, which is objectionable and on every ground to be avoided. This feature, although incorporated in the design of several buildings erected under the author's supervision, has never been used, the farmer seeming to prefer to unload his fresh fodder upon a concrete platform

at the end of the stable, where it is easily pushed down the central passageway rather than carried upon a wagon right into the building.

COW STALLS.—In the past six or eight years various methods of fastening cattle have been devised, from the sanitary as well as the humane standpoint, but practice and expe-

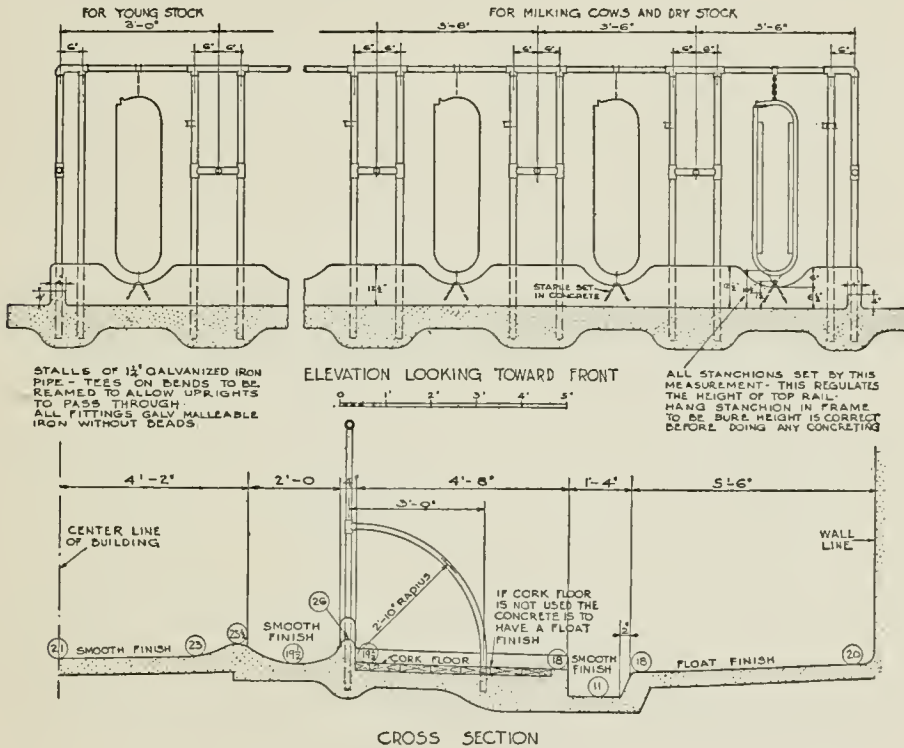

FIG. 7.—DETAIL OF COW STALLS AND STANCHIONS. SEE ALSO PHOTOGRAPH FACING PAGE 32

rience have proved beyond doubt that the steel stanchion, shown in Fig. 7, is the most sanitary way of fastening and is entirely humane. All the other methods are much less satisfactory and we shall discuss only one. Fastening the cow with a tie is sometimes adopted in order to give the animal

greater liberty; this requires chains on the stalls and a collar on the cow, both of which are hard to keep clean. In order to fasten the cow with the tie, the herdsman has to reach over the animal to make one side fast. His eyes and face are always in danger from her horns and when the cattle have been out in the rain his clothes become saturated with water before his task of tying them is completed. The liberty of the animal fastened with a tie, while a little greater, is such as to give her too much freedom. With the stanchions, the cow is kept more in place in the stall, so that the manure drops into the gutter. It is very important for the cleanliness of the herd to keep all the droppings in the gutters and away from the stall floors, lest the cow lie down in her own manure and foul herself. This the stanchion, more rigid than the tie, largely prevents, and cattle soon become accustomed to the stanchion and are entirely comfortable in it. An illustration facing this page shows pipe stall partitions arranged for the tie.

To hold the stanchions a pipe stall is the ideal arrangement; it is sanitary, sightly, and gives excellent ventilation, though care must be used in its construction to avoid all unnecessary bolts and dust-catching crevices, for these require constant cleaning. The pipe partition between the cows has always been considered almost necessary in order to prevent one cow from stepping on another, but in several stables these have been omitted by owners who felt that this theory would not be proved in practice. In some instances it has been and in others not. While the animal is injured less by the proximity of her neighbor than would be supposed, yet such injuries do occur, and though the partition pipes may be omitted for the Grade herd



SHOWING BARN WITH PIPE STALLS ARRANGED FOR THE TIE. THE FRONT OF THE CONCRETE FEEDING-TROUGH IS HIGHER THAN IS DESIRABLE, FROM A PHOTOGRAPH OF THE COW BARN SHOWN IN PLAN IN FIG. 62.

they certainly should not be omitted in the housing of cattle which are at all valuable.

The distance in width from stall to stall is 3 ft., 6 in. for average cows; 3 ft. for young stock, and where special room is required for oxen or cattle of unusual size the stalls may be made 3 ft., 8 in. in width, but this is seldom necessary. For the mature animal the stall floor should measure from 4 ft., 6 in. to 5 ft. in length, and from 4 ft. to 4 ft., 6 in. for young stock. For Jerseys and Guernseys the stall length is 4 ft., 6 in. to 4 ft., 8 in., and for Holsteins 4 ft., 8 in. to 5 ft., the length being the distance from the edge of the gutter to the stall side of the concrete ridge below the stanchion which separates the stall from the feeding-trough (Fig. 7). It is always advisable in a long row of stalls to have them 4 ft., 6 in. in length at one end of the row and 4 ft., 8 in. or 4 ft., 9 in. at the other, slanting the gutter and giving stalls of varying lengths where animals of different sizes or of individual habits may be accommodated. This slanting of the gutter is especially desirable for the young stock, where the stalls may vary in length from 4 ft. to 4 ft., 6 in., and a gutter so slanted may be noticed on the plan of the young stock barn in Fig. 3.

The stall floors must be of some sanitary material, and concrete has been generally used, but this has the objection of being cold in winter. It is possible to cover the concrete stall floors with temporary wooden ones which can be removed in summer; though the wooden floors need attention and become foul without it. Wood blocks, creosoted, are good, and while these are much warmer than concrete, they are not so sanitary, as they become absorbent in time. Cork brick, at the time of writing, have been upon the market two years or more,

and these ought to be, by all appearances, the most satisfactory material for the stall floor yet devised. They are warm, not nearly so hard as concrete, practically non-absorbent, and seem to wear well. They should be laid in cement, not in tar or asphalt, and, to facilitate drainage, with the long joints down the stall and not across it. These brick if laid in tar are objectionable, as the heat from the cow lying on them is sufficient to melt the tar and cause it to stick to the hair of the animal. In the concrete stall and underneath it it is usual, but practically useless, to waterproof the concrete where the animal stands. This is done as an insulation against cold and dampness which might strike through the floor of the stall. An insulation of tar and tar paper will not keep out cold. It will keep out dampness, but no cow barn should ever be built on ground so damp that concrete floors have to be waterproofed in order to be dry. In the stall the insulation of the concrete floor against cold is absolutely essential for the comfort of the animal, but this insulation should be had *above* the concrete floor *and not below it*. Much better than the usual waterproofing underneath the stall is to reënforce the floor slab at this point and excavate a foot or so of the earth beneath it. This keeps the floor entirely above the ground and is infinitely better in assuring dryness than any waterproofing. In fact, by extending the foundations of the gutters and troughs as shown in Fig. 5, and reënforcing the concrete, the entire floor throughout the stable may be raised above ground. This construction costs very little more than the usual method of laying the floor directly upon the earth, and is greatly to be desired.

The stall floor should pitch $1\frac{1}{2}$ in. in its length from the stanchion back to the gutter, and there is nothing in the su-

perstition that this slant of the stall floor is uncomfortable or unhealthy for the cattle, causing them to abort or to otherwise injure themselves. A $1\frac{1}{2}$ -in. pitch to the stall floor is necessary for quick drainage. At the side of the outside stalls, i. e., the end stalls adjoining the passageway, there should be a ridge of concrete, 5 in. or 6 in. high, to hold the bedding within the stall and also to prevent the water in hosing down from wetting it. (Fig. 13.)

CALF PENS.—The smallest dimension of the calf or calving pen is 8 ft. wide by 11 ft. in length. It may be made

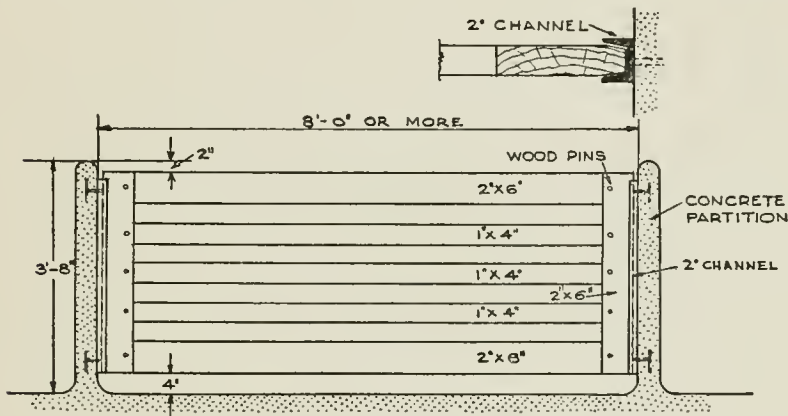

FIG. 8.—DETAIL OF MOVABLE CALF PEN PARTITION

larger if convenient to do so, but not smaller, as a cow needs this amount of space to calve in. This size pen may be subdivided by a movable partition (Fig. 8) when it is desired to keep two calves in the one pen. The calf pen partitions are usually made of solid concrete 3 ft., 8 in. high, and where solid should be kept as low as this so that the animal within may get as much air as possible. Occasionally a particularly agile cow will jump over a 3 ft., 8 in. partition and start to leave the confines of her habitation for the freedom of the

pasture. This happens so seldom, however, that a partition 3 ft., 8 in. high is sufficient. The doors are usually of iron, and when solid a space underneath should be left for ventilation, while upon the floor at the opening, a ridge of concrete

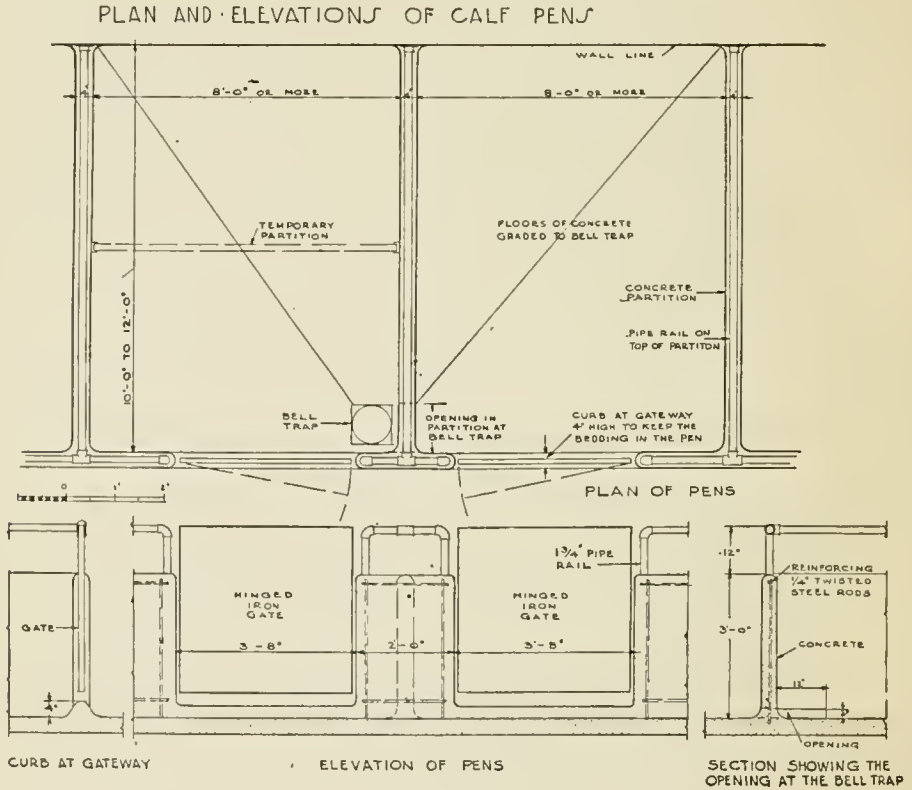
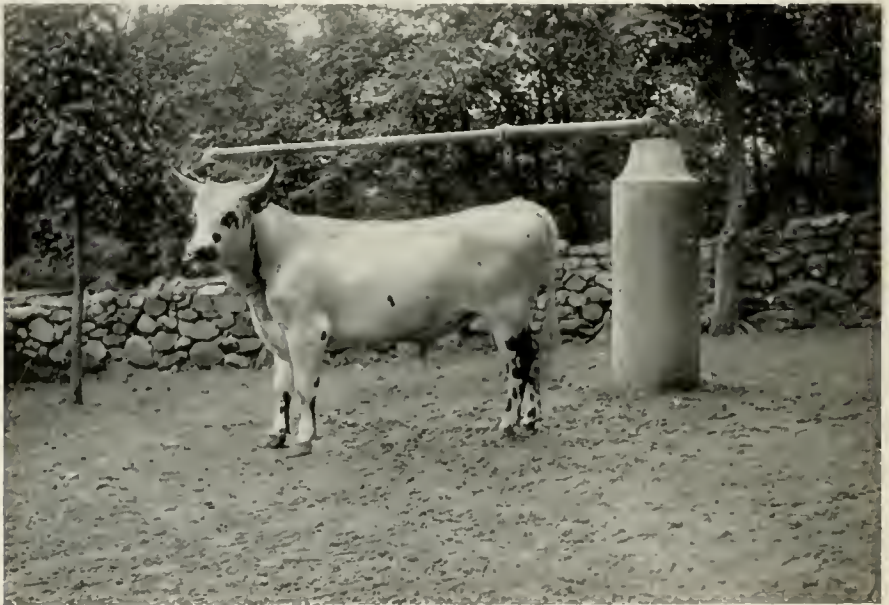

FIG. 9—DETAIL OF CALF PENS

should be formed to prevent the water used in hosing down the passageway from wetting the bedding, and also to hold the bedding within the stall. What seems a better partition is the type shown in Fig. 9—a concrete wall 3 ft. high, with a pipe 12 in. above it. This allows better ventilation. The wooden slatted partition is good but it is hard to keep clean,



A BULL YARD FENCE OF TWO-INCH PIPE



BULL EXERCISER. SKYLANDS FARM, STERLINGTON, N. Y.

and the calf pen enclosure is one that needs constant attention in regard to cleanliness. The floors are always of concrete, but here, as in the cow stall, the cork brick may be used to advantage. In sandy soils the concrete floors may be omitted entirely, though the sand is absorbent and needs to be removed much oftener than is usual. It is better on the whole for the cow to have her calf in a stall with a concrete floor, which can be well hosed down and easily disinfected. The calf pens should always have a sheltered exposure, and in large plans where many young stock are to be provided for, nothing is better than to give them Dutch doors into little yards or runs of their own. A separate yard for young stock is always an advantage.

BULL PENS.—The bull is better kept with the rest of the cattle than by himself, for he is always better natured and more tractable when he can see the other animals. His pen, usually with a post in the center, should not be smaller than 12x14 ft., and if this is made 14x14 ft. the square pen has an advantage. It is always well to give the bull a yard and arrange his quarters so that he may go in or out as he pleases. He appreciates the privilege of the latchkey. The partitions of his pen, always solid, and the more substantial the better, are best increased a foot over the 3 ft., 8 in. height, and this can be done by putting a 2 in. pipe rail on top, for to raise the solid partition to that height would shut out too much air.

The bull's yard may be at a distance from his quarters; if so it is well to give him a shelter there. An exercising pole (Plate facing this page) is sometimes an advantage, especially when he does not brim over with geniality. Secured to this, he may exercise and still have a tincture of confinement in his liberty, frequently appreciated by the man who takes care of

him. The Plate facing page 41 shows the bull's enclosure formed of 2-in. pipe—an excellent enclosure on account of its ventilation, and while it offers effective confinement it does not obscure the visitor's view of its occupant.

WATERING- AND FEEDING-TROUGHES.—The old-fashioned way was to feed the cows in their mangers and to let them drink from buckets. About fifteen years ago there came into the market a separate watering-trough, put on or near the stanchions and controlled by a central leveling tank. This device for watering the cows takes away from the freshness of the water, while the troughs themselves, hard to keep clean, were invariably filled with the dust and dirt of the stable, but the object of this trough was to give each animal a separate watering device and to keep water which has been contaminated by the saliva of one animal from being used by another. This object was accomplished. Latterly it has been the custom to feed and water the cattle in one continuous trough running the whole length of a line of cows. This process of feeding and watering is convenient, the long trough is easy to clean, and its use is general. Still it must be admitted that cows so watered are more liable to infection, one from the other, than when they eat and drink out of separate receptacles. The study of bacteria has demonstrated that the secretions from the mouth are alive with germs, and cows in particular have mouths that exude quantities of saliva which in the natural process of feeding is deposited in many directions. In high-grade cattle it is undoubtedly well to take precaution against possible infection at the feeding-trough, and to feed and water in a trough divided into separate compartments. This arrangement is shown facing this page. No doubt this type of trough increases, though not ma-

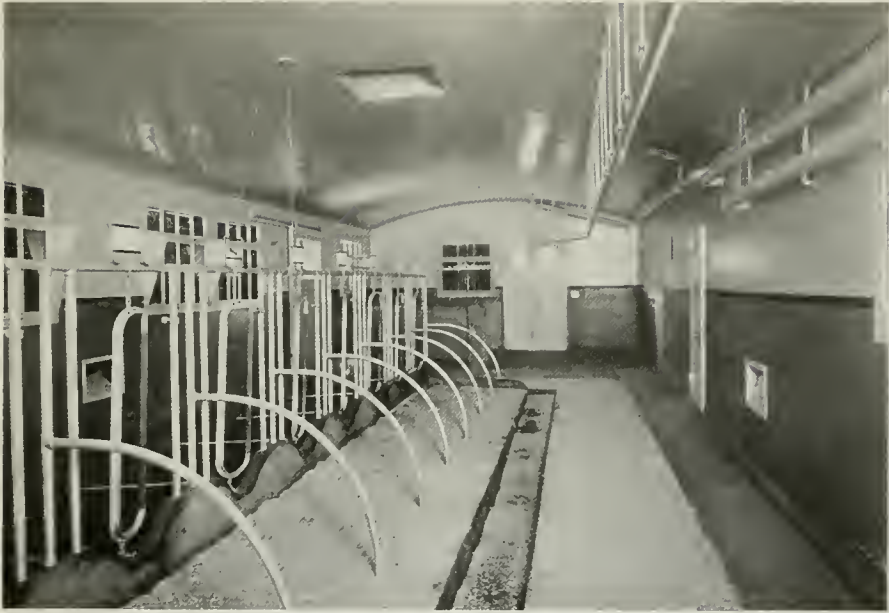

CONTINUOUS FEEDING-TROUGH, DIVIDED BY RODS ONLY



FEEDING-TROUGH DIVIDED INTO COMPARTMENTS

terially, the labor required in keeping it clean; nevertheless, for valuable cattle and for careful methods the divided trough is to be recommended, and it is not in such general use as it should be. This idea of separate feeding and watering may be less rigidly carried out by dividing the general feeding trough so that *two* cows eat from the same compartment. If this method is used, the outlet is best placed in the center

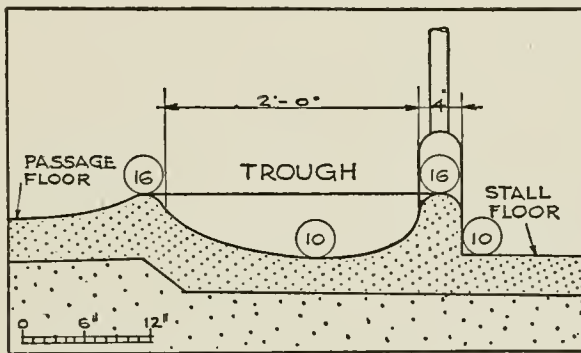

FIG. 10.—FEEDING-TROUGH WITH FRONT EDGE LEVEL WITH THE FLOOR SO THAT FEED PUSHED OUT MAY BE READILY SWEEPED BACK

between the cows, where the water and feed will be drained away from each animal.

For the commercial herd the continuous trough is preferred, and to support this preference it is pointed out that while cows may infect each other by eating and drinking out of the same receptacle, yet it is impossible to keep them from infecting each other in various other ways, under usual conditions and in the natural habits of the animal, such as in grazing over the same pasture, in rubbing and scratching on the same post or corner, and especially in licking one another; so that it is hardly worth while to try and avoid one means of infection where there are many others which cannot be avoided without undue labor and expense. To protect life

by stopping the spread of contagious disease is one of the great impulses of modern science, and it is pretty well established that modern science demands that the herd be tested for tuberculosis every six months, no matter what the type of feeding-trough, and any infected cow immediately isolated.

There are two types of the continuous feeding-trough, one (Fig. 10) some two feet in width and nearly level with the floor, designed with the object of sweeping back the feed which the cows invariably push out in the process of eating;

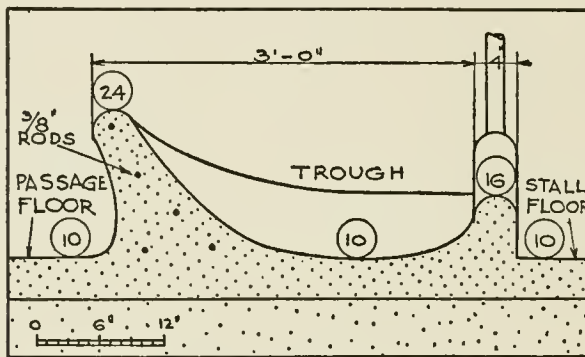

FIG. 11—FEED TROUGH WITH FRONT EDGE 14 IN. ABOVE THE FLOOR SO THAT THE FEED MAY BE RETAINED WITHIN THE TROUGH

the other (Fig. 11), 3 ft., 6 in. in width, its front extended well above the floor and constructed with a view to retaining as much as possible of the feed in the trough. The latter is the better both in principle and practice. The cows' feed should be kept off the floor and the dust and dirt of the floor kept out of the troughs. The study of bovine tuberculosis has demonstrated clearly that tuberculosis of the intestines is much more prevalent than tuberculosis of the lungs. The germs of intestinal tuberculosis are thrown off with the manure and are of necessity deposited, not only in the gutters, but generally around the yards and entrances to the building.

No matter how careful the man who works in the stable may be in matters of cleanliness, he can hardly help carrying on his shoes particles of manure which when he walks in the central passageway will be deposited there upon the floor. In the sweeping back of the feed, pushed out on the floor by the cows, particles of manure, minute though they be, are necessarily swept back with it. These particles may or may not be infected with the tubercular bacilli, but certain it is that the surest way for a cow to contract intestinal tuberculosis is to feed her the germs of that infectious and dread disease. It is apparent, therefore, that it is quite as important to raise the trough well above the floor to partition it from the passageway, as it is to partition it so that the saliva of one animal will not be projected on to the food or into the eating place of another.

By using the narrower trough in preference to the wider one, it is possible to save three feet in the width of the building, but, notwithstanding this reduction in expense, the wide trough is well worth what it costs and should be adopted without question for the thoroughbred herd. The method of draining the troughs, and the plumbing in connection with them, will be shown later, when the plumbing of the cow barn is described.

WATER.—On any country estate there is no luxury equal to quantities of good water, and this is particularly true with reference to the farm barn. Milk is composed of fat, proteids and sugar to the amount of 15 per cent. and water to the amount of 85 per cent., so that good water for the cow is absolutely necessary. It is also equally desirable for the washing of all dairy utensils, which cannot be properly done except in water which is free from sediment and odor. A

man should not be content with any water for his cattle which he would not use for himself.

FLOORS AND FLOOR DRAINAGE.—The floors of the cow barn should never be of wood, and are invariably of concrete 4 in. thick. It is usual to put the concrete floor down in two operations: 3 in. of rough floor mixed in the proportion of 1 part Portland cement to 3 parts sand to 5 parts broken stone or gravel; the finish coat, consisting of 1 part cement to 1½ or 2 parts of sand, is then put on the top, and it is imperative that this be done within twenty-four hours after the rough floor has been laid, otherwise the two layers of concrete will not adhere, the rough usage of the stable breaking the thin top floor from the under one in a short time. It is very important that the floors of the stable be first-class in every way, and therefore none but competent and special masons in this line should be employed upon them. The concrete floors, where the animal walks, are always made with a float finish to avoid slipping, and this finish can hardly be made too rough at first, as it has a tendency to wear smooth; the gutters, on the other hand, the watering- and feeding-troughs and the passageway, where the animal does not walk, are troweled smooth, that they may be easily cleaned. In one stable (facing page 36) wood floors were laid throughout. This was insisted upon by the owner who said that his barns were not for milk, but for the breeding and rearing of his cattle. While admitting the force of this plea in that special case, it nevertheless remains true that for clean milk the wooden floor is on no account to be tolerated, whether in barn or dairy.

An important matter in the comfort of the stable is the floor drainage, always devised with as few bell traps as possible,

and all floors draining so that the water after hosing down will run away and leave the floor to dry quickly. In order to do this a pitch of at least 3-16 in. to the foot is necessary, and this is a minimum grade; $\frac{1}{4}$ -in. to the foot is frequently better. It is almost impossible to lay a long run of concrete floor at a pitch of $\frac{1}{8}$ in. to the foot, in such a manner that hollows will not be formed, where the water will lie. The concrete is also liable to heave a little in certain places, especially when laid on filled ground, and any such movement of the floor will entirely destroy a grade of $\frac{1}{8}$ in. to the foot. For short runs, however, $\frac{1}{8}$ in. will do, and for certain places as much as $\frac{1}{2}$ in. or $\frac{5}{8}$ in. to the foot in pitch is not objectionable. It is better to err on the side of too much pitch rather than too little, for there is nothing which shows lack of care on the part of the architect more than to have the concrete floors retain the water in pools instead of readily conducting it away. A drainage plan of the floors should always be provided, from which the mason and the plumber both can work. As the bell traps are put in before the floors, it is very necessary that these should be located at exactly the proper levels. It is astonishing how frequently the mason and plumber, when left to themselves, will place a bell trap at what seems the very highest spot in the floor. To overcome the combined tendencies of these two gentlemen, it is well to indicate the bell trap on the plan, located $\frac{1}{2}$ in. or $\frac{3}{4}$ in. *below the grade* of the concrete floor, though even this precaution frequently fails.

It is better to leave the bell trap out of the feed room and to drain this room into the cow barn or young stock barn, as the case may be. A bell trap in the feed room is very liable to be clogged by the feed, but if one is put here it would be

well to place it in some out-of-the-way corner rather than in the center of the room.

It is always best, in rows of a dozen cattle or more, to put a bell trap in the passageway between the troughs, to drain the water away from them. Various schemes have been tried with the object of draining the passageways without the bell trap, but this creates other difficulties, and it is not desirable to drain the central passageway into the feeding-troughs themselves. The rear and side passageways drain into the gutter, which should not be less than 7 in. deep at the ends and not over 9 in. or 10 in. at the center. Some cows, during the night, will make 5 in. or 6 in. of manure, so that the gutter must be deep enough to prevent them from fouling themselves. It is wholly impossible to make the gutter pitch to such an extent that the urine will at all times run out of it. The droppings from the cows prevent this, and a pitch of $\frac{1}{8}$ in. to the foot or less is sufficient. In the plan of the large barn shown in Fig. 49, the gutters have been put in level and after cleaning are hosed down and broomed out. The watering-trough, when of the continuous type, need not drain as quickly as is necessary for the floors, and here a pitch of $\frac{1}{8}$ in. or less to the foot will do; if a little water remains in the trough after watering it is of no consequence. The bottom of the trough is better if not located below the floor of the stall, but either above or on a level with it. There is no trouble in getting a good pitch ($\frac{1}{8}$ in. to the foot) in the gutter and trough for ten or twelve cows. In a row of twenty cows the pitch must necessarily be made less, but it is better to have a less pitch than to try to overcome the difficulty by putting another bell trap in the gutter, or a second outlet in the trough. Have as much drainage above the floor and as little beneath

it as possible; the simpler the plumbing is kept the better.

The gutter should be as high on the side toward the passageway as it is on the side next to the stall. A low gutter at the passageway (Fig. 12) will allow the manure in dropping to splash more against the outside walls; while a higher gutter here very largely prevents this.

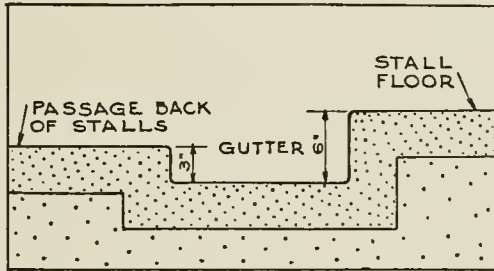

FIG. 12—SHOWING GUTTER WITH LOW SIDE AT PASSAGEWAY. THIS IS UNDESIRABLE

The drainage of the floors of the calf pens should never be effected by a bell trap in the center of the pens themselves, as this invariably gets clogged up, but should drain to the outside of the partitions. Two pens can be arranged to drain into one bell trap, but this should be so contrived that one calf pen can be hosed out without wetting the bedding in the other. A trap outside the calf pens also has some advantage, because by its means the drainage can be taken from the passageway as well. See Fig. 13. In order to keep the bedding in the pen and the water in hosing down out of it, it is necessary to have a small concrete sill, 4 in. high, at the door of the calf pen.

LIQUID MANURE.—Before referring to the plumbing it will be necessary briefly to consider the method of disposing of the liquid manure, which makes a more efficient agent than

the solid manure for fertilizing purposes. So many different views have been presented for the best method of saving the urine, that the system to be chosen will depend largely

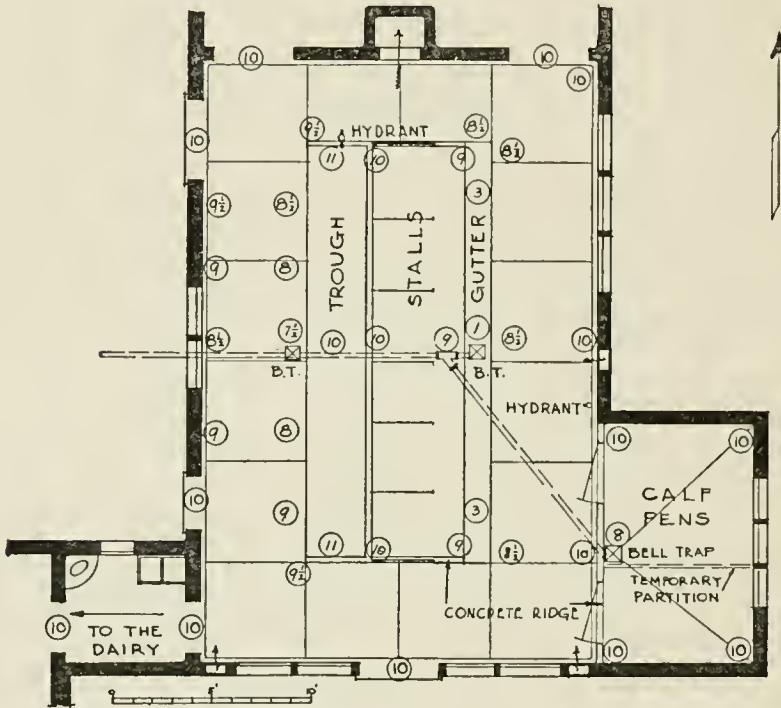

FIG. 13—PLAN SHOWING FLOOR DRAINAGE OF A COW BARN AT GLEN COVE, L. I., FOR CLIFFORD V. BROKAW, ESQ.

upon the preference which each individual has for that particular one.

In large herds, say forty milking cows and upwards, it is certainly desirable to collect the liquid manure in a liquid manure pit, where it can be pumped out, diluted as is necessary, and put upon the land. This is especially so in barns where little or no bedding is used. In the first rush of en-

thusiasm for certified milk, the continual washing down of the cow barn with quantities of water was everywhere advocated. This suggestion was a perfectly natural one from the standpoint of milk cleanliness, but it diluted the urine to such an extent that it was valueless for manure. To avoid this, a special trap for the gutters was designed (Fig. 14.) This is a double trap with two outlets, one outlet for connec-

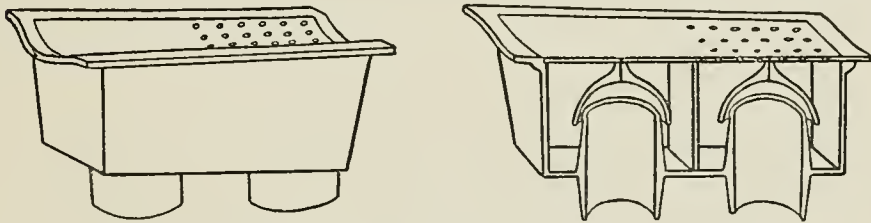

FIG. 14—SPECIAL GUTTER TRAP WITH TWO OUTLETS—ONE TO LIQUID MANURE RECEPTACLE, THE OTHER TO THE SEWAGE DISPOSAL SYSTEM

tion with a liquid manure pit and the other outlet for connection with a general sewage disposal system. The change in conducting the gutter liquids either to the liquid manure pit or to the general sewage system is made by reversing the cover of the trap. This system in a way complicates the plumbing; and it seems so difficult to interest the farm assistant in it that it has for want of intelligent carrying out, been to all intents and purposes abandoned. The continual flooding of the cow barn with water, helpful as this admittedly is in providing ideal conditions for the making of milk, has been found not only, as has been stated above, to dilute the liquid manure unduly, but to make the stable very damp and cold, especially in winter. In several instances which have come under the author's personal knowledge, this damp condition of the cow barn has resulted disastrously to the health of the cows; who, like human beings, are obliged to stay in-

doors more in the winter than at other times. To confine an animal such as the cow, which is especially liable to tuberculosis, in a cold damp room, fast within a stanchion where all exercise is denied it, would seem to be the very height of ignorance and stupidity. When the process of washing down is kept within reason—and once a day is sufficient—the double trap for the liquid manure is unnecessary, and the water from the gutters and troughs may be conducted into the liquid manure pit without damaging the value of the manure as a fertilizer; but even so it is well to have the water from the central passageways diverted into another drainage system along with any other water which can be similarly drawn off. In computing the capacity of a liquid manure pit, allow from 400 to 600 gallons per cow.

In the smaller herd especially, but in the larger one as well, the urine may be saved by banking up the bedding around the gutter bell trap at night, when most of the urine is made, putting plenty of bedding or land plaster in the gutter to absorb it. The absorption of the urine by the bedding greatly aids in rotting it and the liquid manure cannot be utilized to better advantage. In the Briareliff barn, a structure accommodating 200 cows, the plan of which is shown later, this method of saving the urine is used, and some eight hundred feet of gutter has but one outlet. The gutters here are level, nor could they be otherwise without unduly increasing the number of bell traps, and after being cleaned are hosed down and broomed out.

It is never worth while to run the drainage from the cow stable into a general manure pit. This idea is an expensive one to carry out, and experience has shown that it is entirely impracticable.

PLUMBING.—The plumbing required for the cow barn is simple and has been worked out to a perfectly satisfactory solution. All bell traps should be extra heavy and well galvanized. The ordinary iron trap rusts and very soon becomes unsightly. The soil lines from the gutters, within the building, should invariably be of extra heavy cast-iron pipe, and run directly from the bell traps into an outside catch-basin or clean-out pit. Fig. 15 will make this clear. The outlets

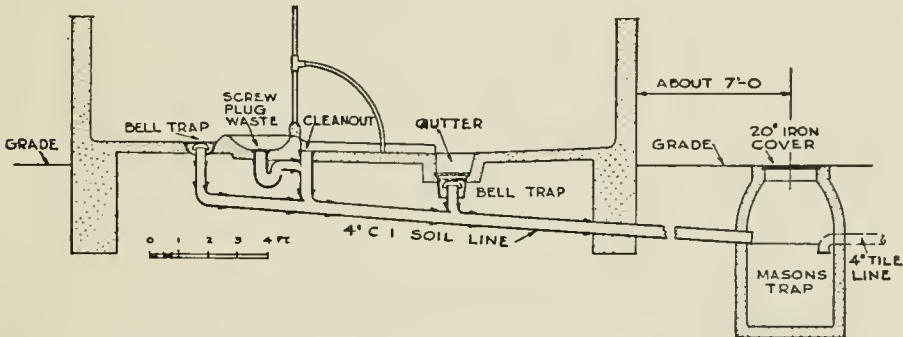

FIG. 15—SECTION THROUGH TROUGH, SHOWING SOIL LINE AND CLEAN-OUT PIT OR MASON'S TRAP

in the watering- and feeding-troughs should always be trapped and drained into the soil line from the gutter, in order that the line draining the gutter may be continually flushed and cleaned by the water from the watering-trough. The outlet from the troughs should not be less than 4 in. in diameter, and a deep-seated plug is necessary to keep the cows from pushing it out; for this reason it is best located between two animals, where it is as far out of their reach as possible. The trap should be set near to the outlet plug, so that a man can clean it out with his hand. A strainer is an advantage, but even so the trap sometimes clogs and must, therefore, be easily reached.

The leaders to the buildings should never be connected with any soil lines, as any stoppage at the end of a leader line will cause the water from the roofs to back up and empty itself through the nearest bell trap on to the stable floor. The leaders must always run into a separate system of their own.

In small stables of six to eight milking cows, the supply at the end of the cow trough will answer all purposes of hosing down. For comfortable watering of stock this should never be less than 2 in., and the hose properly fitted for the connection. In larger stables 1-in. outlets for hosing should be located in the center of each side of the stable and hose racks provided for them. It is not necessary to have a bell trap under this, as whatever drip there is can readily run across the passageway into the gutter. Except in the cow barn proper, all outlets for water should be of the frost-proof hydrant variety, which insures against the annoyance of frozen pipes, but in our climate the outlets in the cow barn need no protection against frost.

For proper cleaning of the troughs and gutters, boiling water is absolutely necessary, so that the cow barn must have in it a connection for steam and water.

VENTILATION.—The subject of ventilation is a trying one, for no matter how carefully the architect may plan his ventilating system, it is almost impossible to find cattlemen who will take the trouble to acquire sufficient knowledge to use it intelligently.

Professor F. H. King, of the University of Wisconsin, has for many years worked carefully and conscientiously over the problem of ventilating the cow barn, and the methods employed to bring fresh air into the quarters for the cow have come to be known as the King system. Those who wish

to go into the matter at greater length cannot do better than to read his little work on ventilation,¹ which is written clearly and interestingly and with such enthusiasm for the subject that the reader lays the book aside feeling as if all the ills of humanity could be attributed to the insufficient ventilation of our homes, schools and farm buildings.

The theory of all exhaust systems of ventilation is to take the air out at the bottom of the room and let it in at the top. This management of the air currents creates a *circulation* absolutely necessary for ventilation. Foul and vitiated air falls and remains near the floor, and from here it should be removed. The fresh air is let in at the top of the room, where the air is the warmest and where the cold outside air may be warmed somewhat before it comes into the range of the individual. All this is usual practice and is sound theory. In rooms which are artificially heated, fresh air may be taken in in sufficient quantity always to insure good ventilation with a comfortable temperature. The difficulty of these principles applied to the cow barn is that the cattle are usually dependent upon the radiation of heat from their bodies for warming their apartment; and that in very cold weather the animals vitiate more air with their breath than they warm with their bodies. A very positive result of this condition is in the condensation on the walls and ceilings, brought about by shutting the building up tight, the moisture from the animals being turned to water on the cold outside partitions. The only way to avoid this is to change the air in the buildings, to remove the moist air within and replace it by the drier air without. Unfortunately, in very cold weather, enough out-

¹ "Ventilation for Dwellings, Rural Schools and Stables," by F. H. King, Madison, Wis. Published by the author, 1908.

side air to stop condensation will sometimes chill the stable and make it too cold. With natural ventilation depending largely on the difference in temperature between indoors and outdoors, it is not only important that enough heat be generated always to keep the temperature within well above that without, but that enough heat be generated indoors to have, not only good ventilation but warmth as well, and the only way to insure such a condition during very cold weather is by artificial heat. With artificial heat all difficulties of ventilation for the cow barn disappear.

The simplest way, as it is the most efficient way, to get air out of the cow barn without opening the doors and windows is to erect a duct which will go from the floor straight up through the roof (Fig. 16), and the higher above the roof this duct is made to run the better it will ventilate. There may and should be two outlet ducts when the number of cows require it. Twenty or twenty-five cattle can do with one outlet duct; more should have two outlet ducts. In Fig. 4, this vent 3x3 ft. inside measurement, is located between the milking cow barn and the young stock barn, and is made to answer for the outlet ventilation of both apartments. Where there is no partition, this vent can run down into the center of the cow barn and occupy the place of one stall, though this seems to sacrifice the sightliness of the stable unnecessarily, however desirable a thing it may be in the case of strictly commercial plants. The large Briareliff barn, shown later in section, was ventilated in this manner.

This duct, called an outlet duct, should be constructed so that it is warm and tight; it will then act just like a chimney, and the higher it is the better it will draw. Its size should be figured at the ratio of 4 sq. ft. (2x2 ft. inside measure-

ments) for twenty cows; assuming that the duct is 30 ft. high; if lower, this ratio must be increased. The factors which operate to force the air upward in the outlet duct are mainly two: the difference in temperature between the air in the building and the air without; and the velocity of air cur-

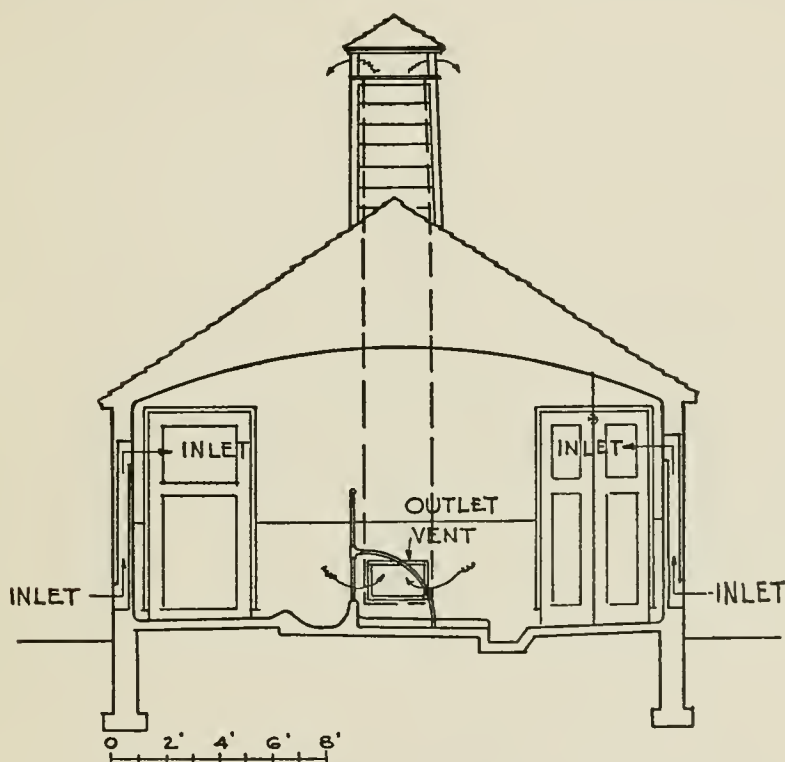

FIG. 16—OUTLET VENT DUCT AT END OF BARN RUNNING FROM FLOOR DIRECT THROUGH ROOF

rents blowing across the top of the outlet duct and inducing by aspiration an upward current within it. In a strong wind the ventilating system is at its best. With no wind it is at its worst, so that judgment of the ventilating equipment must be tempered by the wind. To avoid running the outlet duct

down into the stable, ducts may be placed on each side (Fig. 17), run up the rake of the roof and connected to a central ventilator, the cross-section of which must be equal to the sum of the cross-sections of both side ducts. Where this system is used, a door the same size as the central vent is placed

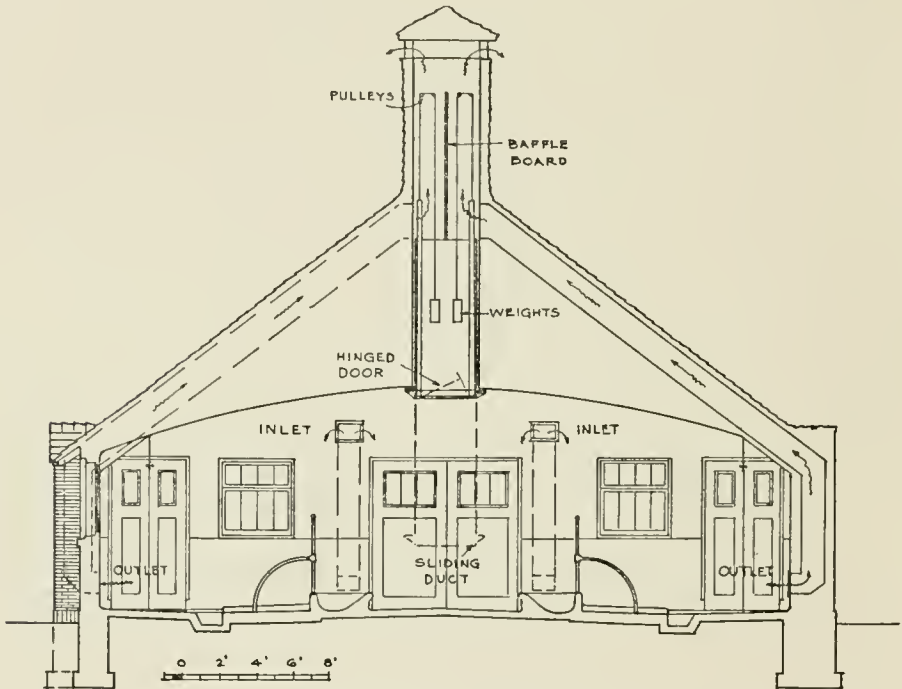

FIG. 17—OUTLET DUCTS IN SIDE WALLS RUN UP THE RAKE OF THE ROOF INTO A CENTRAL VENTILATOR

in the ceiling and is very useful in cooling the stable, especially in the summer. This door should be fitted tight and kept closed during the cold weather.

Another method, and a good one to avoid the unsightliness of the outlet duct in the stable, is to arrange in the center ventilator a duct which will telescope and can be drawn down near the floor at night or at times when such ventilation is

desirable, and pushed up out of the way when the cattle are fed. This type of duct is indicated in Fig. 17, and may be used with the outlet ducts in the side walls or without them.

Another type of the outlet vent at the side of the building is to continue this up straight like a chimney, the higher the better, but it is also necessary to give the cow barn a low, preferably a flat roof, so that the air currents round the top of the duct may not be interfered with by the roof of the building. It is considered that this type of outlet duct gives somewhat better results than where the duct is run up the rake of the roof into a central ventilator, and this scheme adapts itself particularly well for commercial plants.

Whether the outlet duct be at the side of the barn or run down into the interior, it is usual to have two registers in it, each one of which is equal, or nearly so, to the size of the duct itself—one six inches above the floor, the other six inches below the ceiling. For cold weather the lower register is used entirely. The upper register is used when the stable is warm and to reënforce the draft when necessary. The author has ceased to provide the register near the ceiling in cases where other ceiling outlets are available. The upper register in the outlet vent requires in its use a certain amount of intelligence—a quality apt to be conspicuous by its absence in the cow barn. The register at the bottom of the outlet duct simplifies matters and is usually all that is necessary.

These registers are best in the form of small doors, made of iron, and not of the regular louver type, which are expensive and too cumbersome for the farm barn. To make certain of the draft up the outlet duct, steam coils, which always increase the efficiency of the ventilation system, may be placed here.

So much for the outlet duct. Professor King's suggestion

for allowing the air to come into the building is to arrange a series of inlet ducts (Fig. 16) whose combined cross-sections must be equal to the cross-sections of the outlet duct or ducts, which shall take the air in at the bottom and discharge it at the top, some six inches or so below the ceiling level. This traps the warm air at the top of the room and makes its escape impossible except to go downward through the inlet duct which it is not likely to do. While the theory of letting air into the building through the inlet duct is interesting, it has some disadvantages from the point of view of practice. The inlet duct in time becomes dusty and is impossible to keep clean, simply because it is impossible to clean it. For this reason it should always be constructed with smooth sides, galvanized iron being the best material. The air can with quite as much advantage be let into the building through the window, which, falling back in cheeks, will send the current of fresh air up toward the ceiling. The air *may* be sucked out on the leeward side of the building more easily through the window than it would be through the ducts, so that care must be used in regulating them, but no more than would have to be exercised in intelligently operating any system of ventilation. If the cow barn has artificial heating, the inlet ducts may be omitted; if the barn is without artificial heat, the ventilation is bettered by the inlet ducts.

ARTIFICIAL HEAT.—There are differences of opinion with regard to artificial heat in the cow barn. The temperature of the cow barn need never be over 55 degrees Fahrenheit. On very cold nights this degree of temperature cannot be maintained in barns whose location is exposed and which have not their proper complement of cattle. There never was any doubt in the author's mind that properly regulated

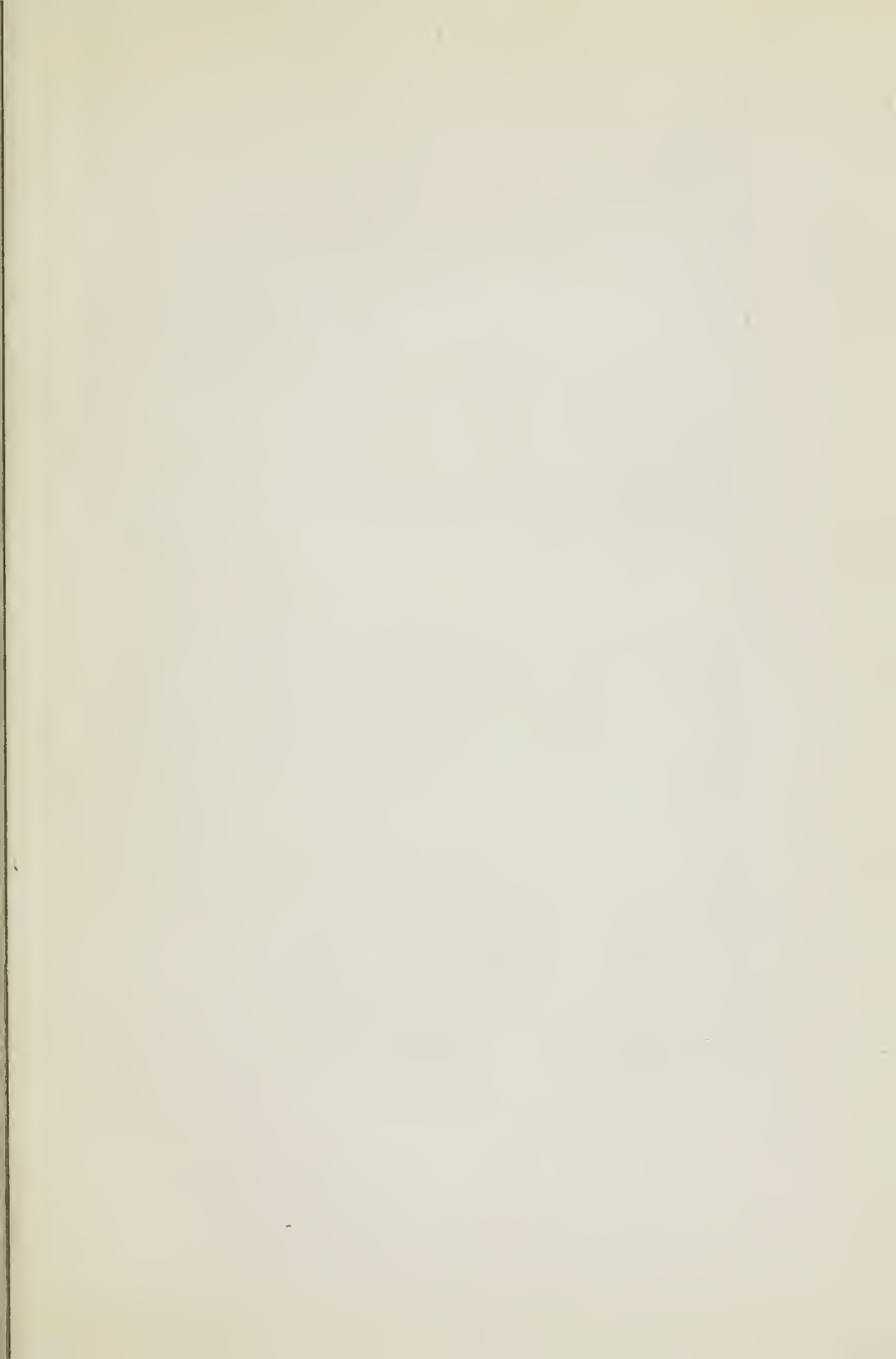



A FEATURE MAY BE MADE OF THE MANURE TROLLEY, THOUGH THIS MAY APPEAR TOO AMBITIOUS IN ITS PRESENT NAKED STATE. WHEN COVERED WITH VINES IT WILL BE SATISFACTORY



MANURE CARRIER AND TROLLEY

artificial heat is a distinct advantage to the comfort of the cow barn. On the other hand, improperly regulated artificial heat can become a great disadvantage, and does become so when the cow barn is kept at a high temperature from which the cattle are removed into the cold outside air. The great advantage of artificial heat is seen in the ventilation. It always allows the taking in of a greater amount of fresh air without chilling the stable. Artificial heat, then, should always mean more ventilation—not less.

MANURE TROLLEY.—The most satisfactory way to remove the manure is by overhead trolley (Plate opposite), and the track should be hung two feet back of the gutter, which brings the carrier in exactly the right position for convenient transfer of the manure from the gutter to the carrier. The carriers are much better and cleaner than the old system of the cart; the wheels of which, if they become foul, grind the dirt into the floor at every revolution. It is possible by the various switches to run the trolley anywhere, and as the switches are efficient and do not get out of order, the tracking of the manure away from the stable is a distinct advantage. In laying out the manure track lines (which are all shown on the various plans) it is frequently desirable to take them through the feed room. It must not be supposed that this is an uncleanly process, as the manure, once put in the carrier, stays there, and the car and contents can pass through the feed room without fouling it. It is almost always more direct to trolley through the feed room than to go around it and it is well to remember that the simplicity in doing the work throughout the whole group of farm buildings is the most important factor in having it well done. If a barn is to be continually clean it must be made easy to keep it so.

Another point to consider is that it is never well to take the manure from one barn through another. While the horse manure and cow manure can be tracked to the same ultimate place, the cow manure should not have to go through the horse barn to get there, or vice versa. The place for unloading the carriers should under no circumstances be near the milking cow barn, but as far away as possible. Here the manure can be thrown directly from the carriers into the manure spreaders and taken to the fields or emptied into a cart and taken daily to a general compost pile or manure pit. All manure draws flies; horse manure breeds them. Absolute cleanliness in this regard is important, for the milking barn can have nothing dirtier in it than the fly. The openings through which the manure trolleys pass should never be narrower than 4 ft. and the trolley will not run on a track whose curve has a radius of less than 3 ft.: this is otherwise a sufficiently flexible apparatus to offer no difficulties of installation even in the smallest building.

The easy handling of the manure and its prompt removal from the cow barn is, perhaps, the most important thing to be considered in the plan and in the administration of that building. Ordinarily it would seem quite superfluous to say this, but milk has been made for so long in unclean surroundings that the mind does not revolt at the idea; and man, being a creature of habit, falls into bad ones much more readily than into good—but never, surely, fell into a worse one than that which accepted and tolerated unclean milk conditions.

BEDDING.—The purpose of this book is to consider the requirements of the farm buildings from the standpoint of the architect, and the reader is referred to others for information on the various subjects of scientific farming. Among

these, soil nutrition is as much discussed at present in its relation to plant welfare as the subject of diet is in regard to human health and happiness. The usual enrichment of the soil is made by manure, and as manure is largely bedding, the importance of the latter to manure is considerable. We will therefore take up the subject of bedding, just so far as it has an effect upon the quality of the milk. There is no doubt that the best bedding from the milk standpoint is planer shavings. These shavings, especially when made from kiln-dried wood, are practically sterilized. They stay in place well upon the stall floor, and shavings make the most sightly bedding as they are the most sanitary.

The farmer, on the other hand, who has other things to consider beside milk production, contends that this bedding does not make good manure; that it takes it longer to rot, and does not contain the plant nutrition that is to be found in manure which is made from bedding the animals with straw. The dairyman replies to the farmer that while the shavings may in some instances lack plant nutrition they also lack the seeds of weeds which ordinary manure frequently has in great quantities; that shavings are better on heavy soils than they are on lighter soils, and on a soil which has a tendency to harden during the dry summer months the manure of cattle bedded with shavings is better than any other kind of manure.

At any rate, shavings make the best bedding for the milk, though with care chopped straw could be used so that it would not injure the milk, especially if taken out of the cow barn before milking, as all bedding should be, whether of shavings or of straw.

In large plans it is necessary to provide a bedding bin. In the small barn the bedding may be stored in the hay barn; if

straw, a bay is given up to it, and if planer shavings are used these come in such a compressed form that very little space is required for them; the bales may be stored in the hay barn or stacked up in the feed room, or the shavings may be stored loose in bins above the feed room and drawn down through chutes.

SILLO.—Ensilage is now used very generally throughout the United States, and the silo must always be considered even in a small group of farm buildings. In estimating its capacity it is usual to figure from twenty to thirty pounds of ensilage a day per animal for 250 or 300 days. In large herds, where two or more silos are required, it is better to have one silo with a larger diameter. The large silo is used in the winter time when cows are fed more on ensilage, and the smaller silo during the warmer months when they are fed less. The reason for this is that it is better to take off from the top of the ensilage at least four inches at each feeding, as there is a tendency for the ensilage to become stale if left exposed for any length of time; consequently a high silo with a smaller diameter is to be preferred. The following table will give reliable dimensions as to silo capacities:

TABLE OF SILO CAPACITIES

Inside Diameter in feet	Inside Height in feet	Estimated Capacity in tons
8	20	20 to 25
8	24	25 " 30
8	30	30 " 35
10	20	30 " 35
10	24	38 " 42
10	26	40 " 46
10	30	45 " 55
12	20	45 " 50
12	24	54 " 60
12	26	58 " 65
12	28	62 " 70
12	30	68 " 75
14	24	70 " 75
14	26	75 " 80
14	28	85 " 90
14	30	90 " 100
14	32	95 " 105
14	34	100 " 110
14	36	105 " 120
16	24	100 " 105
16	26	105 " 110
16	28	110 " 115
16	30	115 " 125
16	32	120 " 130
16	34	130 " 145
16	40	170 " 190
18	26	125 " 135
18	28	130 " 140
18	30	135 " 145
18	32	140 " 155
18	40	190 " 220
20	24	150 " 160
20	30	185 " 200
20	34	215 " 230
22	30	230 " 250
22	38	300 " 350
25	32	310 " 340

The usual silo is the wooden one, and when of wood, cypress is the best material, and it is better to buy the silo from a manufacturer than undertake to construct one with ordinary labor. Concrete silos are entirely satisfactory and are practically indestructible. They can be made either round or square, but are better round; if square the interior angles must be well rounded so that the ensilage will settle evenly and will not be retarded in settlement by catching in sharp angles. The concrete silo has been made with hollow walls, though these have little or no advantage over the solid walls.

The silo, whether of wood or concrete, should invariably be separated from the building by fresh air, as the odors from the ensilage are very pungent and are best kept out of the cow stable. In all cases it is well to have the passage between the silo and the building large enough to contain all the implements used in handling the ensilage, as the odor from them, if not always strong, is persistent. The silo should under no consideration be entered directly from the milking cow barn; the entrance should either occur at the feed room or the silo be entirely separated from the building, as was done in the farm barns at Sterlington, N. Y., for Francis Lynde Stetson, Esq.

Architecturally the silo becomes a difficult problem, for while it is certainly typical of the farm, it is a most unmanageable thing to the architect. Perhaps the best way to dispose of the silo is to place it among the trees, where its rigid outlines are softened, but unfortunately such an environment is not always available, and while it is possible to enclose the silo within a construction that shall partake of the appearance of the rest of the buildings, yet to erect one structure in order to confine another, seems unarchitectural in the extreme.

The wooden silo must always be placed upon a masonry foundation. (Fig. 18.) The bottom, made of concrete and without a bell trap, should extend some four or five feet into the foundations; otherwise if the silo is placed directly on the concrete bottom the juices from the ensilage will leak through

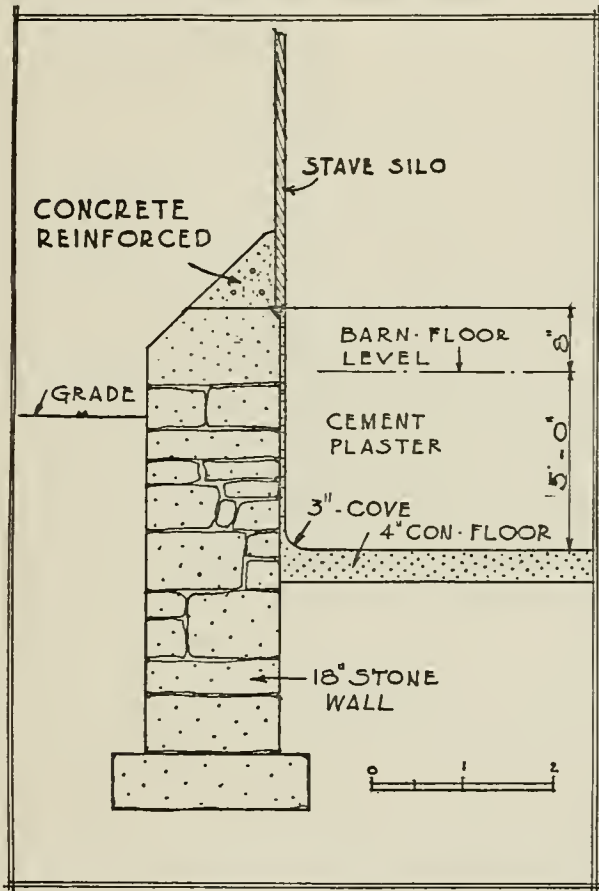

FIG. 18—SECTION THROUGH SILO FOUNDATION

the lower doors. By sinking the floor of the silo, the liquids will be contained within the foundation walls and this undesirable but usual condition avoided.

With any silo, the architect will have to inclose the doors in a chute three feet wide and two feet deep, running from the top of the silo and stopping within seven or eight feet from the floor. As the ensilage is thrown down the chute it is necessary to have light and ventilation at both sides and especially at the top. Care should be taken that no nails are driven through the silo and that no other projections are to be found within it; the interior walls must be perfectly smooth, as it is essential to good ensilage that it shall settle and pack evenly, and so small a thing as a nail point will arrest this settlement and cause the ensilage to spoil at that place. It is best to arrange the concrete floor at the entrance to the silo so that it will drain into a bell trap which is well removed from the place where the ensilage is deposited, for ensilage is composed of so many fine particles that it will invariably clog any bell trap in which it can accumulate.

An excellent type of silo is one entirely without doors, a huge tank open only at the top; the bottom going into the earth some six or eight feet. The ensilage is hoisted out in buckets and a ladder is lowered into the top in order to reach the surface. This makes a little more climbing, as the entire height of the silo must be sealed at every operation, but those who have used this type of silo like it and say that the extra work is very little, and the annoyance of leaky doors is entirely done away with; also that the ensilage is better and more uniform, for any opening which will allow the liquid to leak out, will let the air in and the ensilage will spoil at that point. Such a silo can be very well constructed of masonry and made square if properly reënforced and large coves put in the corners.

The ensilage may be carried to the feeding-troughs by trolley, but it is usual to move it in carts. The various ma-

chines for filling the silo—the blower and the cutter—have been developed to a point at which they are entirely satisfactory, and it is possible to fill a silo forty feet high without inconvenience.

COW YARD.—A yard in which cattle may exercise is just as necessary as any of the other accommodations for the farm barn which we have been considering. In a measure the tendency of modern milking is to focus attention on what seems necessary for the purity of the milk, and to ignore what is beneficial to the health of the cow. She is kept in the stall to avoid exercise, for exercise diminishes the milk flow, and though the author does not pretend to go into the hygiene of cattle, except as it relates to the actual building, he nevertheless wants to protest here against sacrificing the animal for a milk record. The herd must have a proper exercising place located on high dry ground, and well protected from the cold north winds, for the modern method of clipping the cow at all seasons of the year and the continual washing necessary for cleanliness, makes her more susceptible than otherwise to climatic changes.

As the various plans will show, the buildings themselves are frequently arranged so that they form a protected and sheltered enclosure in which it is usual to confine the cattle. This in the main is a satisfactory solution of the problem, though the cow yard adjoining the milking barn is bad from this point of view; for the manure in the yard is soon ground into powder and, especially in summer, is liable to be blown into the milking barn. The cow yard adjoining the milking barn should, therefore, be kept for winter use only, when this objection is partly though not entirely overcome. It is quite feasible to locate the exercising yard at a distance from the cow barn, and this

arrangement is strongly advised in preference to all others. Such a disposition of the cow yard may be seen in the plan of the farm buildings at Sterlington, N. Y. (Fig. 41).

Fig. 19 shows a very practical plan for a small herd of twelve cows and two bulls. The various yards are conveniently

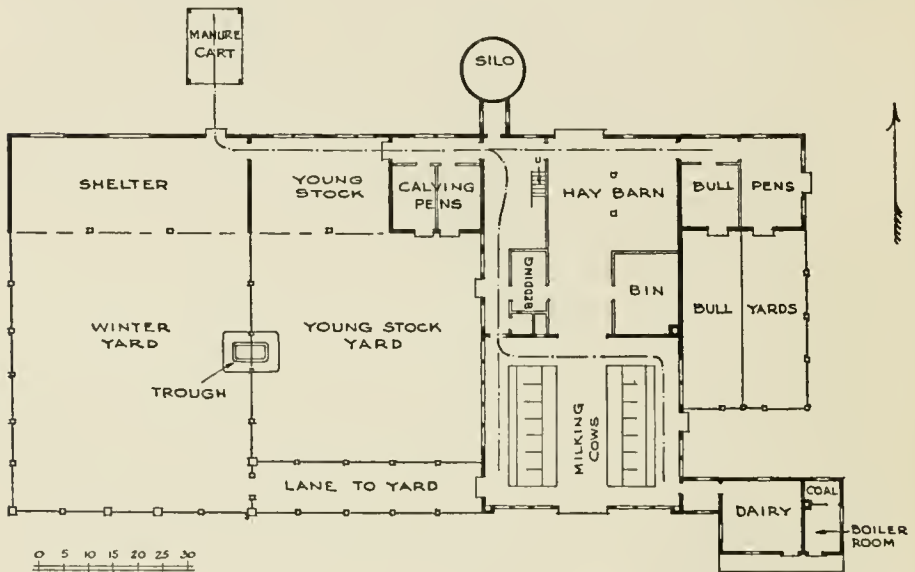

Alfred Hopkins, Architect

FIG. 19.—PLAN OF FARM BUILDINGS AT FRAMINGHAM, MASS., FOR N. I. BOWDITCH, ESQ.

disposed, though too near the milking barn for ideal milk conditions. The owner of this herd, however is not as interested in the making of milk as he is in the breeding of his cattle, and his buildings were therefore designed with that end in view.

In the summer, the proper place for cattle, except at feeding time, is in the pasture, so that the principal need of a sheltered yard is in the winter months. It is well, therefore, to have the isolated yard protected on three sides by a high tight fence, the southerly exposure being left open. In Eng-

land the covered yard has been very largely adopted, though it is not usual in this country, but in cold climates it would certainly be desirable to have an exercising place with a roof for protection from the snows and rains of the winter. Fig. 19 shows such a protection in the form of a wide shed at the end of the cow yard. The eaves are kept as low as possible for shelter, and in the north wall, openings with solid sliding shutters are left for ventilation in the warmer months.

The cow yard must always be kept for the cattle, and should be so arranged that the traffic of the farm need never be brought into it. Such a yard as is shown in the plan for the farm buildings at Oyster Bay, N. Y., for Mortimer L. Schiff, Esq., was not intended as a cow yard, and would be useless as such, for any season of the year, as the horses are driven through it to the sheds and to their own quarters, and there is no part of it where the cattle may enjoy undisturbed quiet.

PAINTING.—For the interior woodwork of the cow barn, enamel paint is much the best. White, though it soils quickly, is preferable for the simple reason that all dirt may be seen. The old idea of choosing colors not to show the dirt is entirely wrong in principle. In places that must necessarily be kept clean and where it is necessary to know whether or not such places are clean, white paint will always give the desired information in a definite manner. Nothing looks better, nor is better, than to enamel the walls and the ceilings of the milking cow barn, and this can be done in a soft cream color and with such material that it is possible to wash down the ceiling and walls. This is a great advantage. It is better not to paint the cement dados, as these frequently want more vigorous scrubbing, and the cement plastering, though sometimes unsightly at first, improves in appearance with age and use and

really gives the best surface without paint. Where the plastering and cement dado come together, a green strip is painted, which must not be of oil paint, as the cement will discolor it. The ironwork for the stalls can be painted in any color desired, or, what is better, brightened with aluminum, which is light in color and though more easily rubbed off than the paint, is more easily renewed and can be kept in better condition with less trouble on that account.

BLINDS AND FLIES.—The fly is the greatest curse to the man interested in making good milk; in fact flies are now being considered a general scourge to the whole of mankind, but to keep them out of the stable is a problem. Screens are entirely inefficient and seem to keep more flies in than they keep out. They are useless. The only way to avoid having flies in the stable is to keep it clean and dark, and it is, therefore, desirable to fit at all windows the ordinary blinds with movable slats. The blinds are hooked in and do not swing, as house blinds do, but occupy the same part of the frame as the storm sash. See Fig. 22. The sash are removed entirely, and the blinds can then be easily operated from the inside. The removal of the sash in summer is important, for they are only in the way and become fly-specked and dirty, and should be taken out and stored until cold weather. The stable is then kept dark, except at milking time, when the smallest amount of light for proper milking is admitted, but care must be taken to hose the blinds down thoroughly, inside and out at least once a day, so as to wash off all particles of dust that may lodge upon them. A reinforced concrete barn is by all odds the best to keep out the flies, as the walls are cold and the flies do not like them. When a concrete building is kept clean and dark the fly problem is solved.

DOORS.—Wherever possible, sliding doors should invariably be used in preference to swing doors. The swing door is a nuisance in a stable. In the hay barn the large doors may sometimes swing out, but even here the sliding type of door is much better.

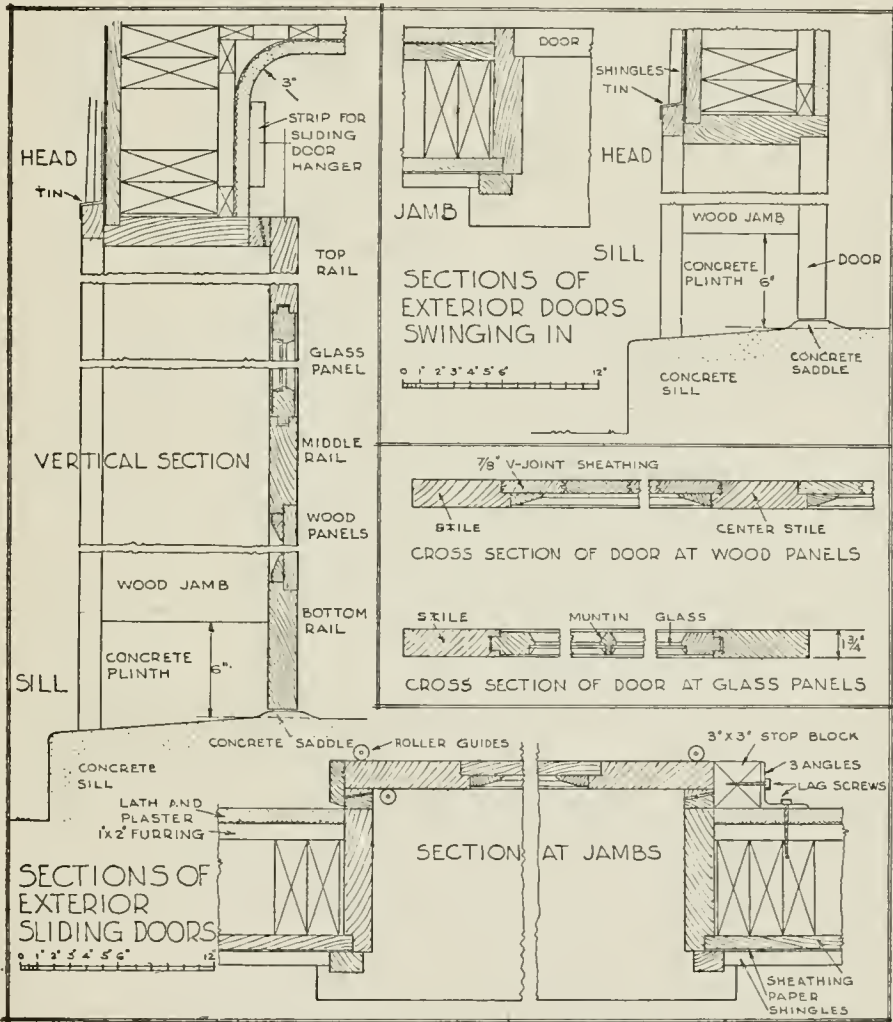

FIG. 20—DETAIL OF THE DOORS FOR THE COW BARN

All doors should be not less than $1\frac{3}{4}$ in. thick, framed together with tongue and tenon, and pinned. It is well to specify that the pins *are to show*, to ensure that the rails are really pinned to the stiles. The moldings in the panels should be very slanting, as shown in Fig. 20, so as to avoid all projections that will catch the dust, and these moldings look well. The inside of all doors should be sheathed smooth. Fig. 20 shows the method of connection between the wooden jamb and the door. It is necessary to have a heavy stop for the sliding

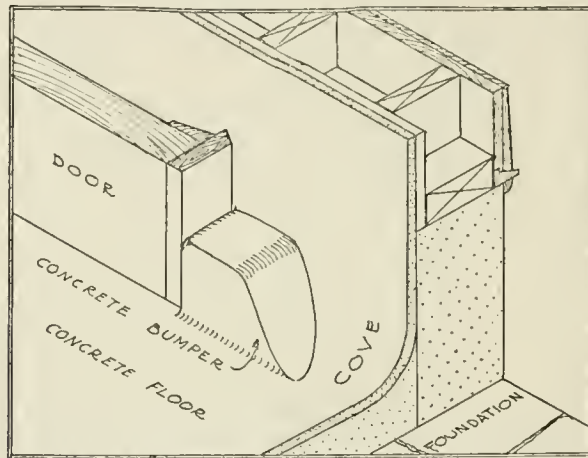

FIG. 21—ISOMETRIC VIEW OF CONCRETE BUMPER FOR DOORS

doors, which can be admirably made upon the floor in concrete (Fig. 21). This is easily the best way to stop a sliding door, and offers an effective resistance. Angle irons screwed on the wall are frequently used for a stop, but they are very hard to keep in place, as the continual banging of the door will in time loosen them, as it will any stop that is applied to the wall; the concrete stop on the floor becomes a part of the actual building itself. All outside doors are best glazed so that they will let in as much light as possible, and inside doors should be

glazed as well, as it is convenient to see from one compartment to another. No door for cattle should be less than 4 ft. in width, and a door 6 ft. in width will enable two cows to go out at a time, though the single door for the cow stable is the usual and generally the better one. The lower half of Dutch doors should be 4 ft., 6 in. high for horses, and for cattle 3 ft., 8 in. is high enough. All Dutch doors should open out and be arranged to hook back flat against the building. All door frames occurring in rooms with concrete floors should have their frames cut off 6 in. from floor and the form of the frame carried out in concrete (Fig. 20). Doors are made 7 ft., 6 in. high for horses; 7 ft. is high enough for cows; and large hay doors are ordinarily made 12 ft. wide and 14 ft. high. They are better not larger than 14 ft. in width and 16 ft. in height, for they become unmanageable when this size is exceeded, and the 12x14 ft. door is sufficient for all but unusual conditions. In machinery rooms for the storing of farm machinery, doors 8 ft. wide by 8 ft. in height are sufficient for all ordinary apparatus; where general driving in is required, doors 9 ft. wide by 8 ft., 6 in. or 9 ft. high will take any ordinary vehicle. A door to take a four-in-hand with man on top must be 11 ft., 6 in. in height. The sprinkling-cart and the steam roller vary so in height that the dimensions of these doors should be governed by individual requirements.

WINDOWS.—As previously stated, the windows in the buildings for animals should be as large and numerous as possible, and Fig. 22 shows an excellent type of window that may be invariably used. This is thoroughly tight, and the section at the sill should be carefully noted. The window sash are not hinged, as they fall back in cheeks, and are thus prevented from coming out entirely. On the other hand, they

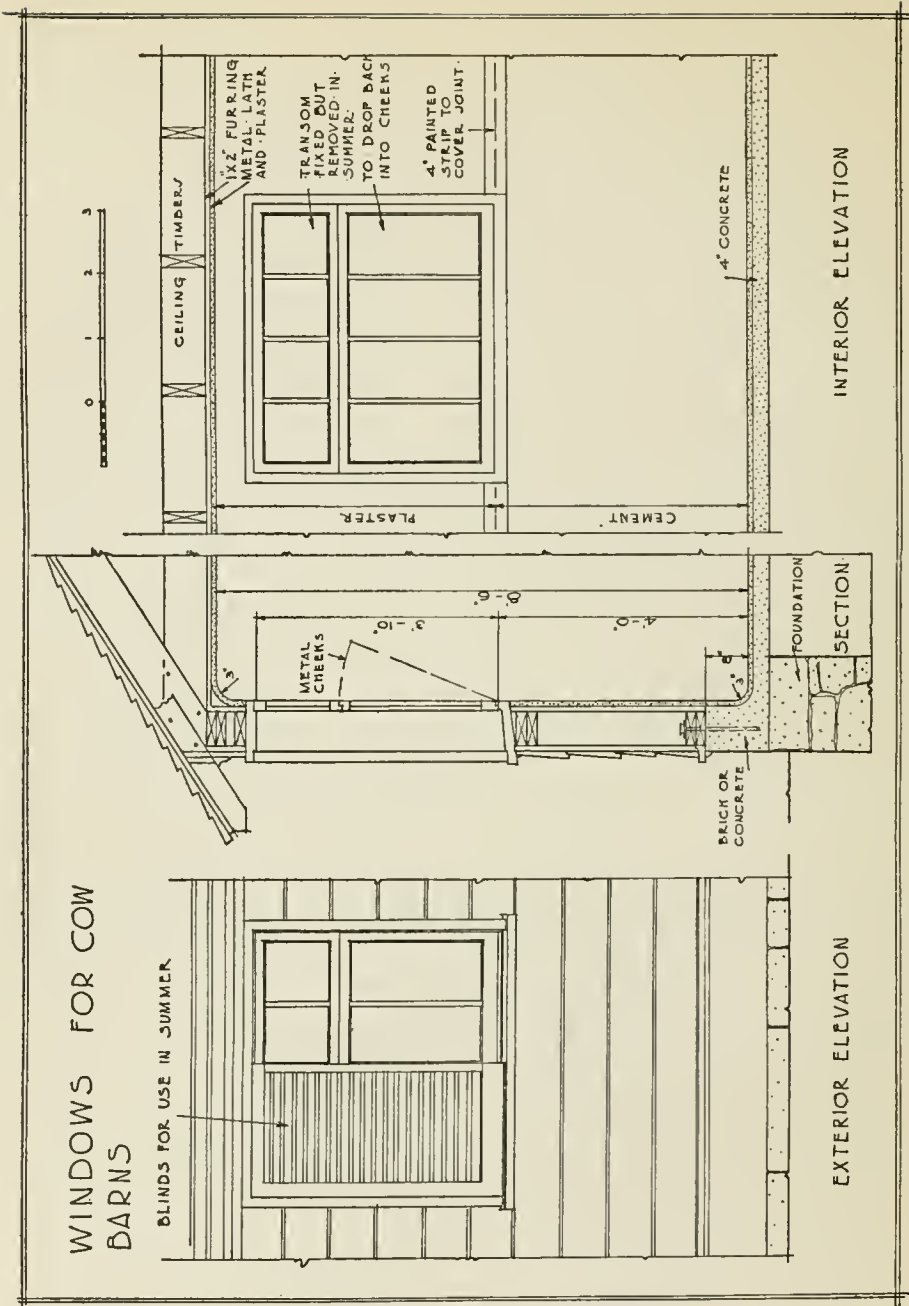

FIG. 22.—DETAIL OF THE WINDOWS FOR THE COW BARN



SHOWING THE METHOD OF SLIDING THE HAY DOOR WHEN THIS IS LOCATED NEAR THE RIDGE. THE TWO LOUVERS AT THE EAVES ARE AT THE TOP OF THE VENTILATING DUCTS FROM THE ROOT CELLAR BELOW



WINDOWS AS SHOWN BY THE DETAIL IN FIG. 22. FARM BUILDINGS FOR CLIFFORD V. BROKAW, ESQ., GLEN COVE, L. I.

can be taken out at will, and should be in the summertime, when the blinds are used instead. The blinds are hooked in and remain stationary in the window openings throughout the summer months. It is possible to close the building entirely by the blinds, and they regulate in a very satisfactory way the amount of light and air admitted. In the wintertime it is advisable to have storm sash in the cow barns, and these occupy the same rabbet as the blinds and are hooked in place in the same manner. The windows, as well as the doors, are best without trim, and the frames should finish flush with the plastering. Even a half-round trim is unsanitary and collects dust to an amazing degree.

Windows in the cow barn should be 3 ft., 8 in. from the floor and run up as near to the ceiling as possible. The flanges on the cheeks at the side of the window must be arranged so that the sash may be easily taken out, and windows which occur in calf pens and in horse stalls must always have grills to keep the animals from breaking the glass.

In the dairy the best form is the double-hung window. In a way this is not quite so sanitary as the casement which comes flush with the wall. The difficulty with the casement window is that it is impossible to fasten it conveniently when open, and in the dairy rooms, where windows should be numerous, the proper swinging of the casement window is frequently obstructed by the piping. Altogether the double-hung window is better for the dairy, but it should very rarely be used in the farm barn.

UTENSILS.—The utensils for cleaning the barn and the cows—the shovels, brooms, brushes, etc., are best kept on slate shelves and hung against the concrete walls of the feed room. When they are clean they are not unsightly, but quite the re-

verse. A special place has been assigned them in the plan shown by Fig. 3, where they are intended to be cleaned as well as stored. A cupboard is not the place for them. Iron cupboards with outside ventilation have been tried, but it is impossible to keep any closet which is closed by a door from becoming foul and infected with rubbish. To hang the utensils on the walls or place them on slate shelves, and to keep all in plain view and where any uncleanliness is detected at once, is the only solution of the problem.

We have now set forth the requirements of the cow barn in all their detail and carefully considered them in the light of modern sanitary research. Though good milk needs the accommodations of a dairy for its further care, it must be remembered that *the actual quality of the product is established at the cow barn*, and that milk will never be better than it is when it leaves there. As the next step in its production has to do with the dairy, we will now proceed to a discussion of that building.

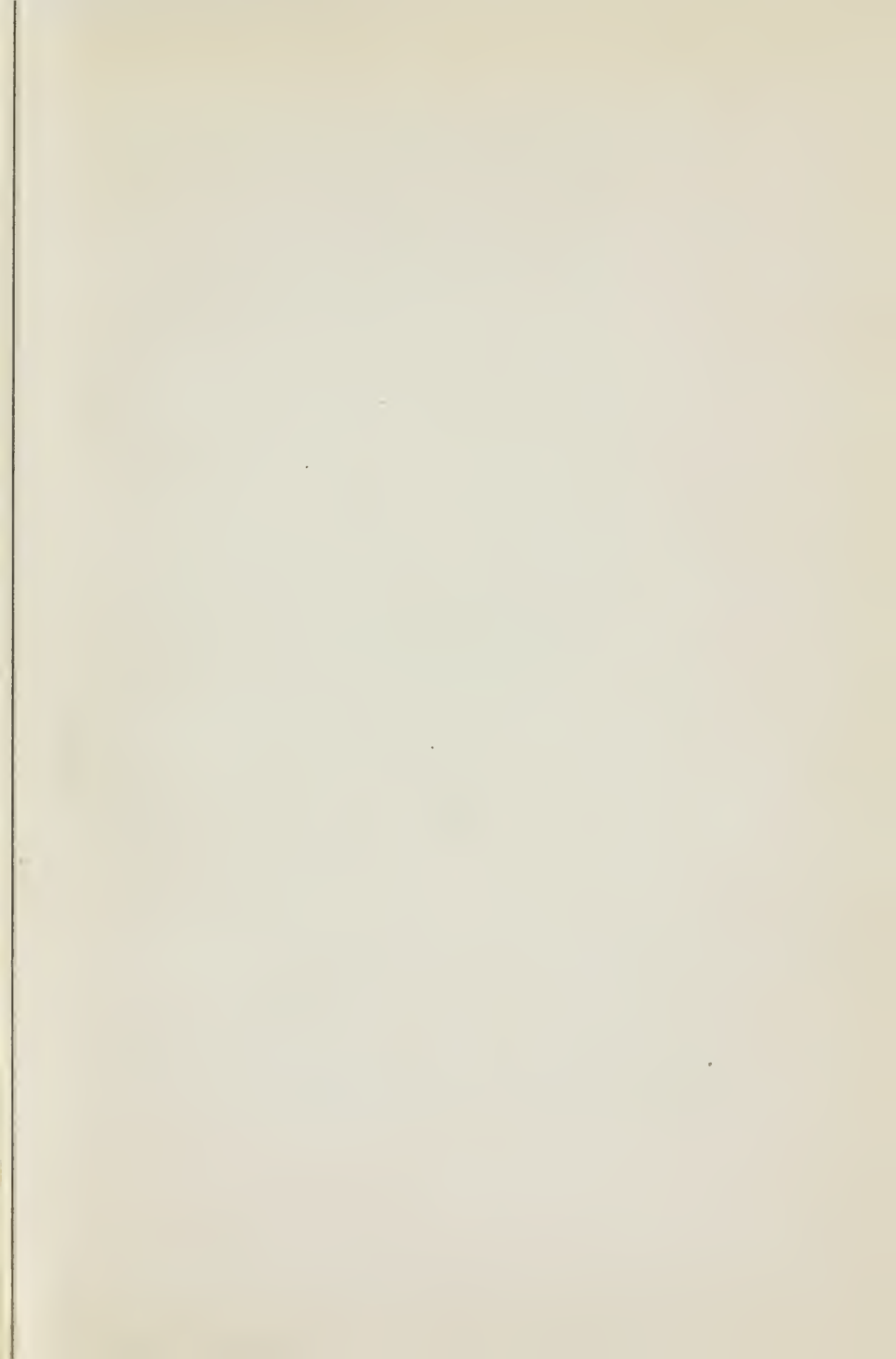



A CORNER OF THE DAIRY. FARM BUILDINGS FOR MORTIMER L. SCHIFF, ESQ., OYSTER BAY, L. I.

CHAPTER III

THE DAIRY

THE location of the dairy should be such as shall be most convenient for the simple and easy handling of the milk after it has been drawn from the cow. In large herds of a hundred milking cows or more, it is probably better to locate the dairy at a distance and take the milk to it either by trolley or by cart. It was thought at one time that, for sanitary purposes, the dairy should be at least 75 ft. distant from the cow barn, but this is not so—provided, however, that the cow barn is properly designed and cared for. It is much easier to take care of milk in the dairy than in the cow barn, and if it were necessary to choose between a clean dairy and a clean cow barn, it would be preferable to choose the clean cow barn. Here it is that milk is most exposed to contamination and here it is that most milk is contaminated. Consequently, with a clean cow barn—and all the plans and data which have here been laboriously compiled are for the sole purpose of having a clean cow barn—it is not in the least objectionable to locate the dairy adjoining the cow barn, and even to connect it by a roof, so long as it is separated by fresh air. Care should be taken, however, to keep the dairy roof lines low and to place it so that it will shut out as little as possible the air and light from the cow barn. The larger the dairy building is, the further it should be removed from the quarters of the animals. An ideal disposition, if the grade permits, would be to lower the

floor of the dairy four or five feet, so that from the level of the cow barn floor the milk might be poured directly over the cooler in the milk room.

In planning the dairy and its equipment it is necessary to know approximately how much milk is to be taken care of, and it is usual to figure ten quarts (or twenty pounds) a day

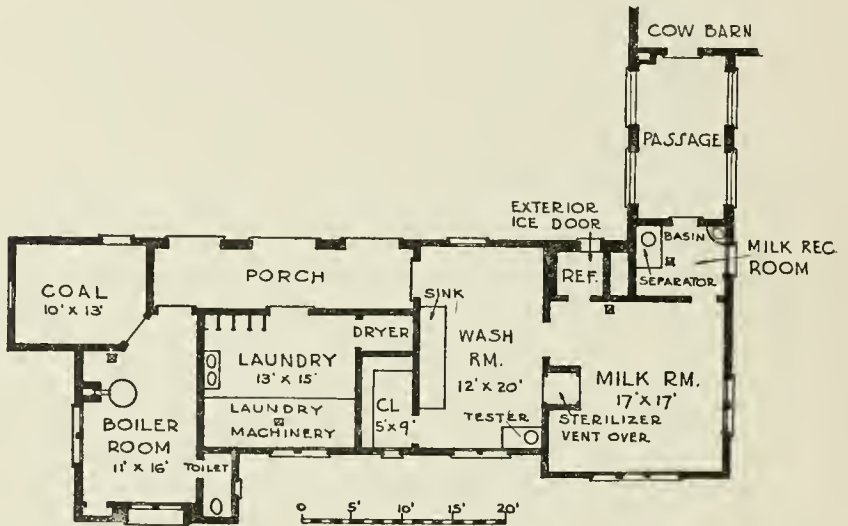

FIG. 23—DAIRY AT OAKDALE, L. I., FOR F. G. BOURNE, ESQ.

per milking cow. This is rather more than the average of a Grade herd, and less than the average of a thoroughbred herd containing cows of advanced registry, but it is a dependable estimate and can be used at all times.

In the dairy the care of the milk can be brought about in a much more flexible manner than is possible in the cow barn. Fairly proper and adequate dairy accommodations may be found in a building of two rooms—or even of one. Fig 23 shows a more generous solution of the requirements of the

dairy building, and we will take this as a typical plan, reviewing the smaller building later. This plan provides for a milk receiving room, milk room, wash room, storage closet, laundry, boiler room, and a toilet room for the men. The method of caring for the milk in the dairy may best be explained by describing each room and its use separately, and in detail. We will take the rooms up in the order mentioned and commence with the milk receiving room.

MILK RECEIVING ROOM.—Here the cans of milk are received, and the disposition of this room is such that it is possible to pour the milk directly from the milk receiving room over the cooler without bringing the cans themselves or having the men who deliver them come into the milk room proper. This room is very necessary in large plants, but in smaller ones its necessity diminishes, so that in the smallest type of the private dairy there is no objection to bringing the milk in the can from the cow stable directly into the milk room. In the present plan, Fig. 23, it is expected that the milk will be brought in the pail to the milk receiving room, where it will be weighed and its record kept. The milk will be poured from the pail into a 20-qt. can which will then be taken into the milk room by the dairyman, cooled and bottled. The separator is located in the milk receiving room, as the skimmed milk is generally used as feed and will not be kept in the dairy; it is therefore better that it should not come into the dairy at all. It is always better to keep the separator outside of the milk room proper, as it is a piece of machinery that in a way is difficult to keep clean. In smaller dairies with no milk receiving room, the separator is better in the wash room than in the milk room. It is important however that the location always be such that the separator may be conveniently seen to by the

dairyman, who has to give it almost constant supervision when in use.

MILK ROOM.—In the milk room the milk is cooled and bottled. It is not our purpose to go into a long bacterial analysis of the reasons requiring the cooling of milk; practical experience and scientific research have demonstrated as a fact that the sooner milk is cooled after having been drawn from the animal the longer it will keep. The reasons for *quick* cooling are briefly these: milk has in it a certain germicide property which tends to keep it sterile for the space of one or two hours after having been drawn from the cow. Bacteria will not develop readily in milk until after this time. By cooling milk to a temperature at which bacteria will not grow rapidly, 50 degrees Fahrenheit or under, this germicide property in the milk is retained, so that if, in the process of using the milk, it should reach a higher degree of temperature, 60 degrees or 70 degrees, where bacteria commence to grow rapidly, this germicide quality remains effective even at a later date, and prevents the growth of bacteria for a short time. Quick and adequate cooling, therefore, is always essential.

Now as to the degree of temperature desirable: probably the ideal is 34 degrees to 40 degrees, but this frequently entails much expense, and for the smaller dairy is not always feasible. If milk is cooled to between 40 and 50 degrees it is entirely satisfactory for the private plant, but it must be kept at all times below 50 degrees, as in a higher temperature bacterial growth commences. With a mechanical refrigerating plant it is not a difficult matter to get the milk down to 34 or 35 degrees immediately, but it is also possible to get sufficiently low temperatures by much simpler methods. The simplest of these is to stand the usual 20-qt. cans in a barrel of ice-water.



CONCRETE VAT IN WHICH THE TWENTY-QUART CANS ARE PACKED
IN ICE

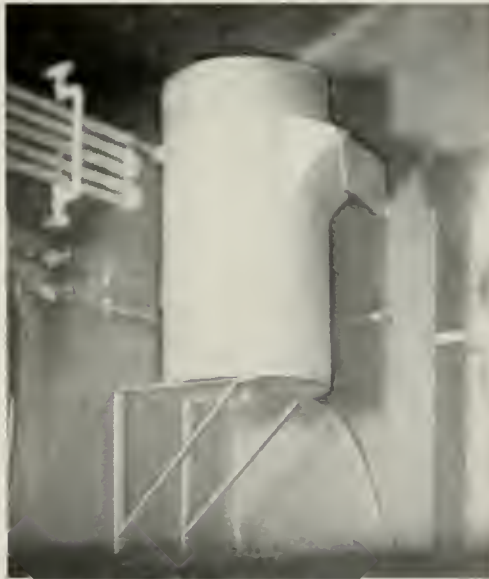

GALVANIZED IRON CAN ARRANGED
FOR HOLDING ICE-WATER. IT IS
CONNECTED TO THE WATER SUPPLY,
AND CRACKED ICE IS PUT IN THE
HOPPER AT THE SIDE

or pack them in ice (facing p. 82). The milk from the milk-er's pail is then poured into them. While the cooling of the milk in cans is not as immediately effective as other more expensive methods, it is an entirely satisfactory one for small herds, where it is essential that their product be taken care of by the simplest and most inexpensive process. The time taken to lower the temperature of the milk to the desired point by this method of cooling may be greatly shortened by stirring with a long-handled milk rod, but this must be very carefully done, and usually more harm is brought about by stirring to obtain quicker cooling than would occur if the milk were left to cool more slowly by itself. The great point in the care of milk is to do just as little to it as possible. The fewer things it touches in the process of cooling, the better. It is solely the quantity of milk to be cared for which determines the manner of cooling and makes some methods preferable to others.

Another variety of this idea is to have the bottle-filling table made with high sides, packing the bottles in ice and filling them with the warm milk. The bulk of milk being smaller, the process of cooling will be quicker and a low degree of temperature more easily maintained. Of all the methods of cooling readily accomplished, this is perhaps the best, though it is better adapted to the large than to the small plant.

The usual way of cooling milk is to run it over a milk cooler, of which there are several varieties. All are made on the same principle: a metal receptacle filled with ice-water, over which the milk flows. During the process of cooling, the cooler is kept filled with flowing ice-water, which must enter at the bottom and flow away at the top. The warm milk poured over the cooler at the top runs down and at the bottom is chilled by the freshest and therefore the coldest ice-

water, which comes in contact with the cooler at that point. While the milk cooler continues in general use and is doubtless desirable under many conditions, it has always seemed to the author a utensil which was liable at any time to do quite as much harm as good. It is one more thing to keep clean, and one more thing, when not clean, to contaminate the milk. If milk can be cooled either in the can or in the bottle, and the milk cooler eliminated, it is always better in theory and frequently better in practice. As before stated, the fewer things milk touches, the better. The elimination of every unnecessary contact is a point gained.

Where the cooler is used, ice-water is required and there are various plans for collecting it by means of the storage of ice in the refrigerator. For instance, large coils of pipe are sometimes placed in the bottom of the ice chamber, in the hope that the ice resting on them will cool the water as it passes through. This method only cools the water that has been standing in the pipes, and, as soon as circulation commences, ceases to be effective. The pipe coil, however, affords a small supply of water at a very low temperature which is useful in butter making, and it is not a bad idea to have this coil in the refrigerator even when other means are used for milk cooling.

Another method of obtaining cold water for cooling is to place a perforated coil above the ice in the refrigerator, which will spray it; the water will then collect at the bottom of the ice chamber and from there it can be run through the cooler. Though wasteful of ice, this is an entirely satisfactory way of getting water in sufficient quantities at a low temperature. Water so cooled can be gotten to 34 degrees, and where ice can be obtained at small cost it is by far the simplest and most efficient way to get ice-water with which to cool the milk.

Another way and a good one, is to place above the level of the cooler a large tank, which may be filled with water and ice. This tank, sometimes placed in the milk room itself, is better located in the wash room. If this method is used to any extent, a separate place for this tank could well be provided at some point away from either the dairy room or wash room, but where ice may be had conveniently. Ice-water made as just described is not as cold as that obtained by spraying the ice, but, on the other hand, it is much less extravagant in the use of ice.

In conclusion, we do not wish to involve the cooling of milk in an agony of detail and to confuse the mind of the man who is choosing between one method and another. Milk when it leaves the cow is approximately at 90 degrees; in the summer, by the time it is ready to go over the cooler, it may be 80 degrees. If 30 degrees can be taken out of it, bringing it down to 50 degrees when it goes into the refrigerator, in bottles, this is all that is really required. Lower temperatures, though commendable, are not a necessity. All the suggestions here recorded are adequate for cooling milk; each method will give the same degree of temperature if persisted in long enough, and, temperature for temperature, one method is probably as economical as another. There seems to be in the human mind, especially if that mind is interested in an economical administration of a farm, a decided inclination to save in the use of the commodities which give the extremes of temperature—ice and coal. As it happens, good milk requires an abundance of both heat and cold, an unfortunate fact but one that must not be winked at, so that the man who really wishes good milk must give himself up to what he will probably feel is riotous dissipation in this regard. If he wants to avail him-

self of the scientific methods of the modern refrigerating plant, then he should employ someone especially qualified to carry out this line of work. Where ice can be had at reasonable cost, there is no need of a refrigerating plant for milk cooling, except in the large commercial establishment.

The location of the cooler requires some consideration with regard to its height above the floor. This should be sufficient to allow the bottles to be filled at a convenient level. An illustration, opposite, shows a satisfactory arrangement for the smaller problem. It will be seen that it is generally necessary to elevate the platform from which the milk is poured and the various plans will show this done in various ways.

Just as surely as it is necessary to cool milk, the proper and only way to use and to keep milk is to store it in bottles and not in bulk. The best type of bottle is one as free from lettering as possible, and if lettered the letters should be very flat for easy cleaning. After the bottle is filled and capped with a sterilized paper cap, the neck should be wrapped with paper to keep the edge of the bottle from soiling. The caps are sometimes parafined, but this is necessary only for commercial milk. Various fixtures have been devised for filling bottles in sets of four, eight and twelve at a time. For the purposes of the private plant, however, a small bottle-filler, filling four bottles at a time, is all that is necessary. As soon as the milk has been bottled and cooled, it should be put at once into the refrigerator; this may open directly into the milk room or into the wash room. After the milk is capped in the bottle it may be taken anywhere in the dairy without fear of contamination. In large plants the refrigerator must not open into the milk room, but outside of it, so that shipment of milk may be made without going into the milk room.



LARGE MILK COOLER FOR COMMERCIAL PLANT, BOTTLING-TABLE WITH HIGH SIDES FOR PACKING BOTTLES IN ICE

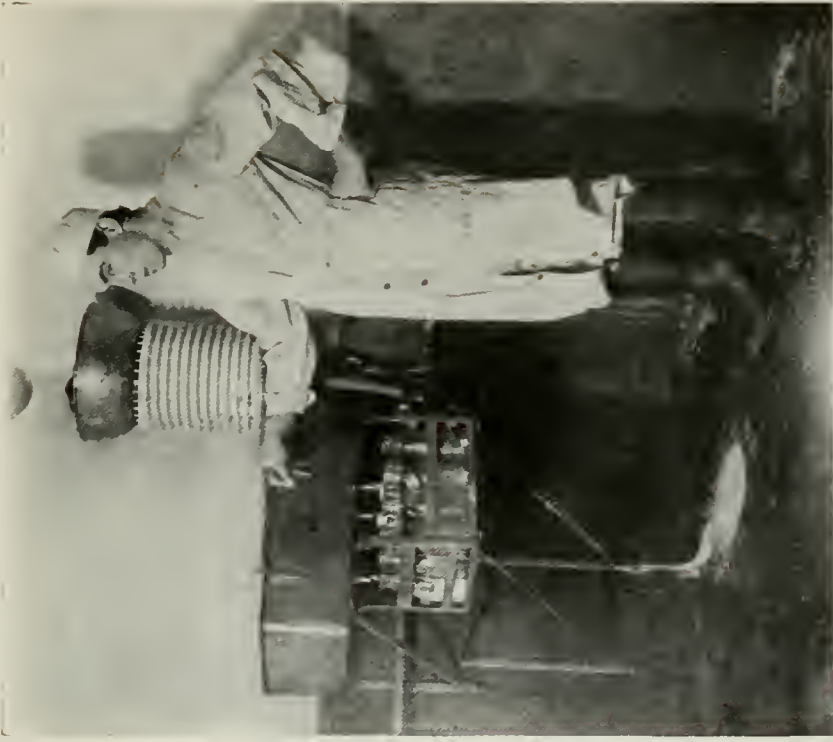

COOLER AND BOTTLE FILLER. THE HERDSMAN, POSING FOR THE MOMENT AS A DAIRYMAN, WAS SO OCCUPIED WITH HAVING HIS PICTURE TAKEN THAT HE ALLOWED THE MILK TO SPILL UPON THE FLOOR

Fig. 28 shows the plan of a commercial dairy which gives the usual and an entirely satisfactory location of the refrigerator.

The refrigerator, like the silo, is generally best purchased from a manufacturer of refrigerators. It is always more attractive when lined with glass, and should be so lined for the

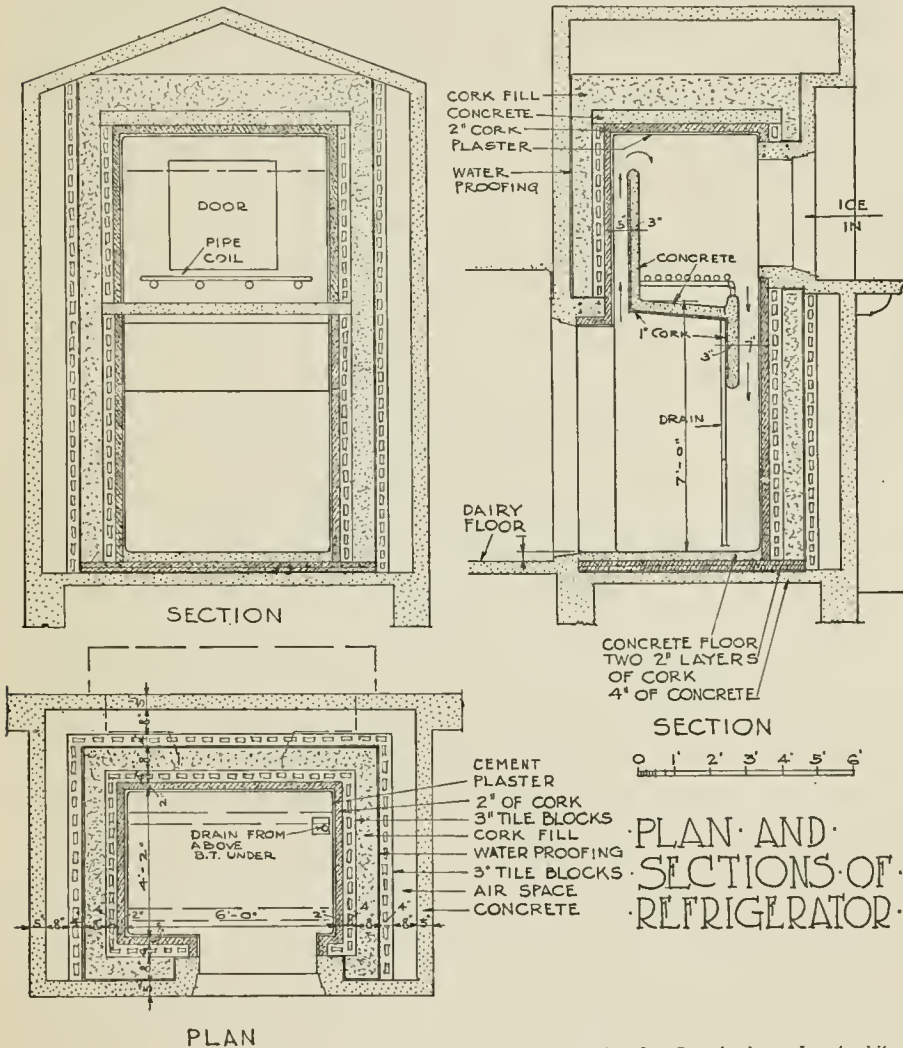

Stanley Cunningham, Jr., Architect

FIG. 24—DETAIL OF CONCRETE REFRIGERATOR

private dairy. For years the author drew plans for the refrigerators and had them built by the general contractor, but it is cheaper and better to get them from those who are specialists in that line. Where the buildings are of reënforced concrete, or for a commercial plant, there is nothing better than a reënforced concrete refrigerator. It is non-absorbent and practically indestructible. Fig. 24 shows one in detail which proved entirely satisfactory and was incorporated in the farm buildings, the plan of which is shown on page 141.

The butter worker, the churn and the cream ripening vat are usually placed in the milk room of the smaller dairy.

WASH ROOM.—The wash room is for the purpose of washing all the utensils, and a very satisfactory sink made of galvanized iron (opposite) has been developed for this work. In the larger dairy building, good sinks of about the same design have been made in concrete, but they must be constructed by men competent to do this work, and such men are hard to find. The galvanized iron sink is of stock manufacture and answers all purposes for usual conditions. It is designed with two large compartments for general washing, and over one is placed a steam turbine bottle washer. At one end of the sink is a steam jet for washing cans, pails, etc.; at the other is a rinsing jet for rinsing the bottles after washing. The bottles are rinsed after placing them in the cases, and the jet is arranged to rinse four bottles at a time, the cases holding either eight bottles in two groups of four, or twelve bottles in three groups of four. As the paper caps used for capping the bottles, bits of broken glass, etc., are liable to get into the sink, it is better not connected direct to the soil lines as is ordinarily done, but to empty into a bell trap which shall not only act as the outlet for the waste water of the sink, but take the wash



THE DAIRY WASH SINK



PIPE-RACK TABLE—TWO VARIETIES

on the floor as well. This system of draining the sink is important, and entirely prevents the stoppage of the plumbing pipes by litter and waste that would otherwise clog them.

In connection with the work of the dairy, and generally in the wash room, it is well to have a pipe rack table, a very useful, serviceable and sanitary piece of dairy furniture.

The Babcock tester for determining the percentage of butter fat in milk, has come into general use, and indeed is necessary for intelligent dairying. This should be located in the wash room; situated, however, so that the exhaust from the turbine can go out through the wall, as these machines are made cheaply and the exhaust from them must be exceptionally free in order that they work well. A slate slab is a good surface for it to stand on, and in connection with this a sink near at hand is desirable. The large sink will answer if it is reasonably convenient.

An important matter is the REAL sterilization of all the utensils of the dairy. This is best done by means of the high-pressure sterilizer (facing page 90) which is large in size and expensive in first cost. All the utensils are put in here, the door is closed, and the contents are subjected to a steam pressure of ten pounds; this gives a temperature of 240 degrees Fahrenheit, which is absolutely destructive to all germ life. For large dairies and where the best type of service is wanted, this is the thing, but in smaller dairies the high-pressure sterilizer is not absolutely essential, and nearly the same result may be obtained by using a steam chest into which the utensils are put as into the large sterilizer, and here subjected to a CONTINUOUS FLOW of live steam. Any utensil subjected to live steam for twenty minutes is perfectly sterilized, but the difficulty of the steam chest, or low-pressure sterilizer, is that

in filling it with the various utensils some are liable to get the flow of live steam less advantageously than others; so that its work is not so definite in every detail as the larger and heavier instrument. While the greater cost of the high-pressure sterilizer¹ precludes its use in the smaller dairy, yet there is no doubt that it is more efficient than the low-pressure fixture. Either sterilizer affords a perfect storage place for the utensils of the dairy after sterilizing, and these should always remain there until the time comes to use them. This refers to everything used in the production of milk—the milking-stools, milk pails, cans, coolers, milk bottles, etc. As subsequent plans will show, the sterilizer—opening at each end—has one door in the wash room, the other in the milk room.

In connection with the wash room it is always desirable to have a store room for barrels of washing solution, extra bottles, caps and supplies, and these are best provided for on slate shelves. A store room should always have light and ventilation and need not necessarily open from the wash room; it can open from any other room or passageway except the milk room, which must always be kept inviolate.

LAUNDRY.—Any milking which is properly done should be done in milking suits, fresh at each milking, and the one-piece suit is the best. It is therefore desirable to have a small laundry for washing not only the suits themselves, but the towels, hand cloths, etc., used in the work of obtaining clean milk. The laundry machinery (opposite) is all of stock patterns, and these fixtures can be run by a motor, if electricity is to be had, or by a small steam engine. All

¹ The price of the sterilizer in the catalogue of The Rutland Mfg. Company is \$735. There is a discount, however, from this price.

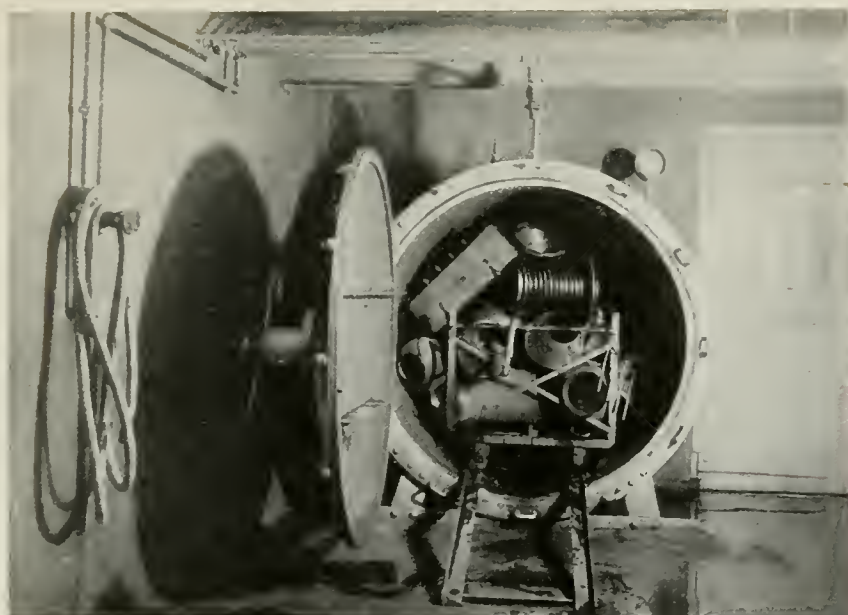

HIGH-PRESSURE STERILIZER FILLED WITH DAIRY UTENSILS
READY FOR STERILIZING

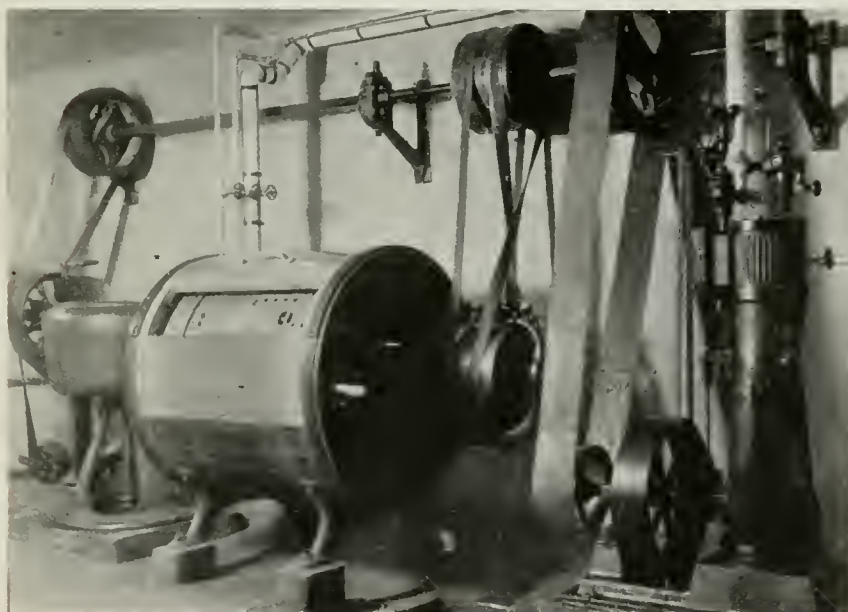

LAUNDRY MACHINERY FOR THE DAIRY

suits, cloths, etc., are rough-dried and need not be ironed. In the laundry the same system of drainage should be used as that employed for the wash room sink—the washing fixtures emptying into a bell trap which serves for the floor drainage as well. In the plan shown in Fig. 23, two wash-basins and lockers have been added in the laundry for the men's use preparatory to milking. It was formerly the custom to provide a separate wash room for the men, but for the establishment we are discussing, the washing place for the milkers is very well contained in the laundry. In connection with the laundry work there must be provided a dryer for drying the suits; this is no more than a closet with iron doors and steam coils on each side. Between these the rack on which the washed garments are hung is rolled. This little room must have outside ventilation with an inlet of fresh air at the bottom and an outlet for the warm air at the top. The suits and cloths should be left in here until they are required for use, just as the utensils for dairying are left in the sterilizer. This drying-room may also be used as a sterilizing-closet for the men's suits, and a perforated steam pipe in addition to the pipes for heating may be installed to advantage. The closet is filled with steam, and the suits, after washing, are sterilized in the same manner as the various utensils are sterilized, in the low-pressure sterilizer by a continuous flow of live steam. This is carrying things rather farther than absolutely necessary, but anyone especially interested in the extreme scientific view of milk production can indulge his fancy to his advantage by sterilizing the milkers' clothes. Ordinarily, clothes washed clean with soap and hot water answer every requirement. The best receptacle for the soiled suits is a large galvanized iron can with a cover, similar to an

ash can, which it is quite proper to keep in the laundry. It should stand on legs and care should be taken to keep it clean. A similar can is necessary for the washing solution used in the wash room. The laundry washing is done with soft soap, made up in a receptacle furnished with the laundry fixtures.

BOILER ROOM: LIVE STEAM.—Even the smallest dairy requires live steam properly to clean utensils which have been soiled by milk, and it is much better to have a small high-pressure steam boiler and subject all utensils to live steam than to use hot water. Hot water cannot be used hot enough and it does not clean sufficiently. Anyone can prove this statement if he will sterilize a milk can in the high-pressure sterilizer and wash another with hot water, put the covers tightly on both and stand them in the sun for six hours. If he will then remove the covers he can tell without any scientific analysis, other than that made by his nose, which can has been sterilized and which has not. In dairies, the general scope of which is similar to the one we have been considering, it is well to have a fairly good-sized boiler room, that a place may be had for a work-bench where a small amount of tinkering can be done. The floor of the boiler room is drained by a bell trap so placed that the boiler may be blown off over it.

The location of the water-closet for the men has always been a trying problem. To put this off the boiler room, as indicated, is to locate it in perhaps the least objectionable place. Here it has the advantage of warmth and remoteness from everything connected with the milk. To make the isolation more complete, it has sometimes been planned with an outside door only, but this is bad in practice as it makes constant supervision difficult. A modern fixture which is kept scrupulously clean at all times would hardly be objectionable

at any convenient point. On the other hand a dirty fixture would be objectionable at every point. The uncertainty as to condition creates the uncertainty as to position, and anyone who is able to control the former may readily point out the latter.

We have previously dwelt upon the absolute necessity of live steam for the cleaning of the floors, walls and ceilings, and of all utensils, not only in the dairy but in the cow barn, and for this a very simple and effective fixture has been devised,



FIG. 25—McDANIEL'S SUCTION T,
FROM WHICH COLD WATER, STEAM
OR HOT WATER MAY BE DRAWN

the trade name of which is McDaniel's Suction T (Fig. 25). This is piped to water and to live steam, so that it is possible to get cold water or live steam or any combination of the two from the same jet. Every room in the dairy, the compartment of the milking cows and the dry stock barn, should have this connection, so that the floors and walls may be hosed down with boiling water. It is almost impossible to clean some feeds from the feeding-trough without boiling water, and we cannot emphasize too strongly the importance of live steam. Good dairying cannot be done without it.

PLANS OF DAIRIES

While the plan of the dairy we have been considering is a liberal housing of the dairy apparatus, yet satisfactory milk

can be made with simpler accommodations, and we now take up briefly a few plans of smaller dairies which have worked out well and in which the important features we have referred to have been embodied.

Fig. 26 shows a building containing a milk room, a wash

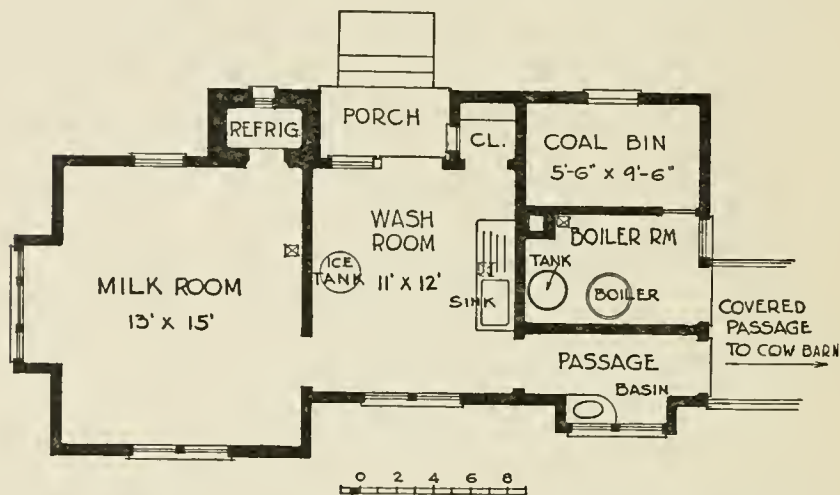

Designed by Stanley Cunningham, Jr.

FIG. 26—PLAN OF SMALL DAIRY AT ROSLYN, L. I., FOR BENJAMIN STERN, ESQ.

room and a boiler room. The lavatory for the men is put in the passageway to the cow barn, which is made sufficiently large to contain a wash-basin and two lockers. As the site was constricted, the building being placed in the obtuse angle formed by two roads, the refrigerator was located at the milk room, so that it could be easily filled from the road. The milk in this dairy was cooled from a tank of ice-water put in the wash room and piped through the wall into the dairy room. The "empties" come back into the wash room through an outside entrance at the rear. In this little building no sterilizing closet was installed. It is possible with care to clean

very thoroughly the milk bottles and utensils by jets of live steam at the wash sink. While this method is better than washing with hot water only, it is not so efficient as the low-pressure sterilizer, and a soiled utensil cannot be sterilized with certainty in this manner.

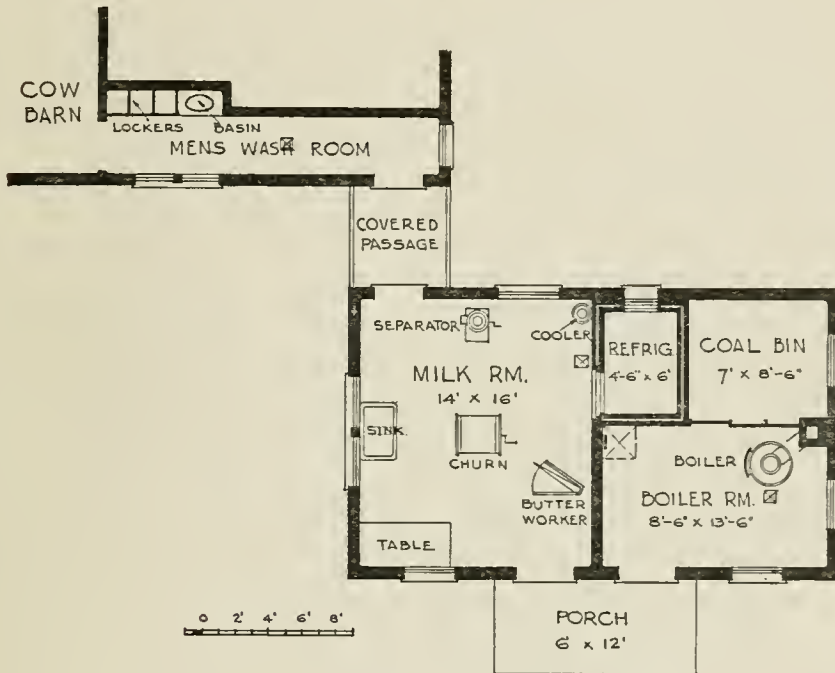

FIG. 27—DAIRY AT HARTSDALE, MASS.

A still simpler type of dairy is shown in Fig. 27. A passage was taken off from the feed room in an existing cow stable. Here were located three lockers and a wash-basin, the latter opposite the window, for a man washing his hands preparatory to milking must have good light in order to see that they are clean. The dairy, as all dairies shown, is separated from the cow barn by a passageway. The milk is here taken care of in the one room, equipped with a sink, milk cooler, a

pipe rack table, separator, churn and butter worker. The cooler next to the refrigerator was cooled by water collected in the refrigerator. The boiler room is of fair size, with a coal bunker sufficient for a season's supply of coal. This dairy plan is the simplest solution of the problem, and efficient if run on modern methods.

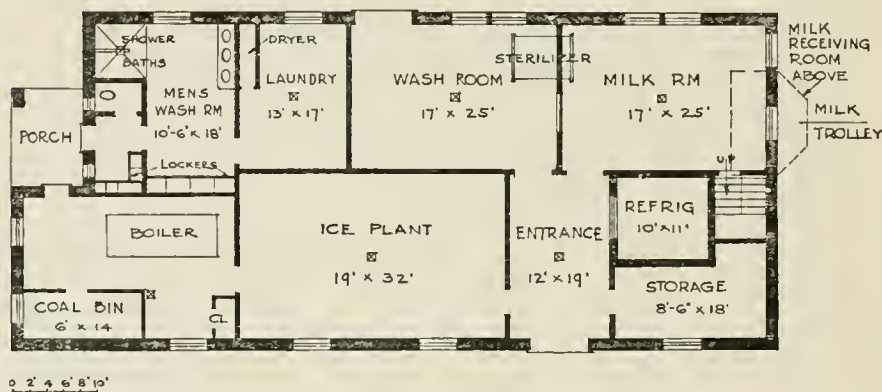

FIG. 28—PLAN OF DAIRY AT CEDARHURST, L. I.

Fig. 28 shows a plan of a commercial dairy designed to take care of one hundred milking cows. This dairy was located at a distance from the farm barn, the milk being sent to it on an elevated trolley. This practice was considered advisable at that time, but with the improved methods of caring for the stable and the increasing proof had on every side that stables can be kept clean, the practice of locating the dairy away from a milking stable of no more than a hundred cows is decreasing. The milk from the barn in 20-qt. cans was received in the milk receiving room, the floor of which is 8 ft. above the level of the floor of the milk room. From the milk receiving room, the milk is poured either directly over the cooler or into the receiving vat for the separator. In this in-

stance the milk is cooled by artificial refrigeration. After the milk is bottled and capped, it is placed in the refrigerator, from which shipment is made without going into the milk room. In large plants, as previously pointed out, it ought not to be necessary to go into the milk room for the shipping of milk, and in this plan the milk room is isolated so that no traffic through it is necessary; in fact no one was allowed in the milk room without a sterilized suit and milk cap on, and those wishing to see the process of taking care of the milk could do so by looking through the large plate glass window in the partition between the wash room and the milk room. This is a feature always advisable in the large dairy.

The men's wash room, with shower, basins and lockers, adjoins the laundry, where the suits were washed, sterilized and dried, and the toilet located off the men's entrance did not prove to be objectionable here. A storage room and office is placed at the entrance. This dairy follows out in every particular the requirements of certified milk, and can easily provide for the quantity of milk which a herd of seventy-five or a hundred milking cows would produce.

HEATING AND VENTILATING OF THE DAIRY.—

The dairy requires some thought as to its ventilation, especially the larger structure. It is well to arrange an outlet vent between the milk room and the wash room so that ventilation from both rooms may be had through it. If a scuttle is put in the ceiling for ventilation—and it is not advisable—it should never be over the bottling-table, but always in one corner of the room and as far removed as possible from those places where the milk will be exposed. It is advocated by some that the fresh air be let in through an inlet duct in the side wall, but this does not seem to be any advantage, the duct

forming a place where dust will lodge and where it is difficult to dislodge it. If such inlet ducts are put in the dairy, it is well to have the interior register faces open on hinges, so that the ducts, plastered smooth on the inside and drained at the bottom, may be thoroughly washed out. Air is better let into the building through the window, all windows being screened with muslin screens, arranged so that the muslin may be taken out and either washed or renewed. The muslin clarifies the air coming through it and becomes astonishingly dusty in a short time. Ordinarily the dairy needs very little ventilation and is better without it when the milk is exposed. Before using the milk room, it should be filled with live steam, which not only acts as a sterilizer, but also precipitates the dust. The same sanitary methods of construction should be used in the dairy as suggested for the cow barn, and all projections and moldings should be eliminated; the walls and ceilings plastered in cement, and the floors made of concrete, never of wood.

All the rooms should be heated, though not much heat is required in either the wash room or the milk room if the high-pressure sterilizer is installed. The best type of radiation is the steam coil, which should always be placed on the walls and never on the ceiling, for in washing down the dairy rooms the water drips from the ceiling coils, which for this reason are objectionable.

CHAPTER IV

ADMINISTRATION

IT seems better to continue here with the subject of administration while the details of the cow barn and dairy building are still fresh in mind; for in the making of clean milk it is the method of doing the work which really counts. Carelessness in this regard will very quickly offset the advantages of a well-equipped dairy barn, and, on the other hand, careful methods can produce excellent milk from inferior buildings and equipment. Even the bacteriologist feels that the number of bacteria counted on his microscope plate is an insignificant matter compared with the general administration of a dairy plant. Dr. Rowland G. Freeman has stated his opinion as to the importance of controlling the source of the milk supply rather than to attempt to determine its character by bacteria counts, in these words:

“It seems to me that while the counts of bacteria are exceedingly valuable as an exponent of cleanliness and proper handling of milk, they should be used only to prevent carelessness at the dairy and to stimulate better methods and discipline. The opinion of a milk commission of representative men (experts), based on an actual knowledge of the management of the dairy, is of vastly more value to the medical profession and to the public than any statement regarding the precise number of bacteria in the milk upon any given day or days. The most important thing, after all, is such a régime

as shall make contamination by pathogenic organisms improbable, and at the same time insure that the milk is produced under such conditions of cleanliness that other bacterial contaminations will be reduced to the minimum.”

The author has been sorely tried many times at seeing a complete and expensive group of buildings turned over to ignorance and sloth and allowed to become dirty and foul through neglect.

To begin with, we must repeat that in the modern farm barn the great contaminator of milk is dust, and that milk is primarily infected with bacteria during the process of milking. The importance of a cow barn free from dust is so apparent that a number of schemes have been tried by which the cows were completely cleaned and groomed and then taken to a “milking barn,” where they were milked, either the entire herd at once, or in relays. Nothing was done in the milking barn but the milking. Theoretically this is an interesting idea and—for nursery milk and the like—ought to be adopted. There are, however, very few building problems that are not limited by the cost, and the general adoption of this scheme has been prevented on that account, though it ought to be more generally used, especially for the smaller herd. Fig. 29 shows this idea in detail. The milking barn scheme settles the matter of bedding very readily, as with this plan the bedding is kept away from the milk, and the cleaning of the cows outside the room in which they are milked is an advantage.¹

¹Since this was written, the author has learned that some who have tried the idea of cleaning the cows in one barn and milking them in another, object to it for this reason: that moving the cows after cleaning to the milking barn excites them so that they will not let down their milk and, consequently, there is a falling off in the milk record. If the transfer of the animals is made quietly, there is no reason why the quantity of milk should suffer from it. But it does show how necessary it is that the cleaning,

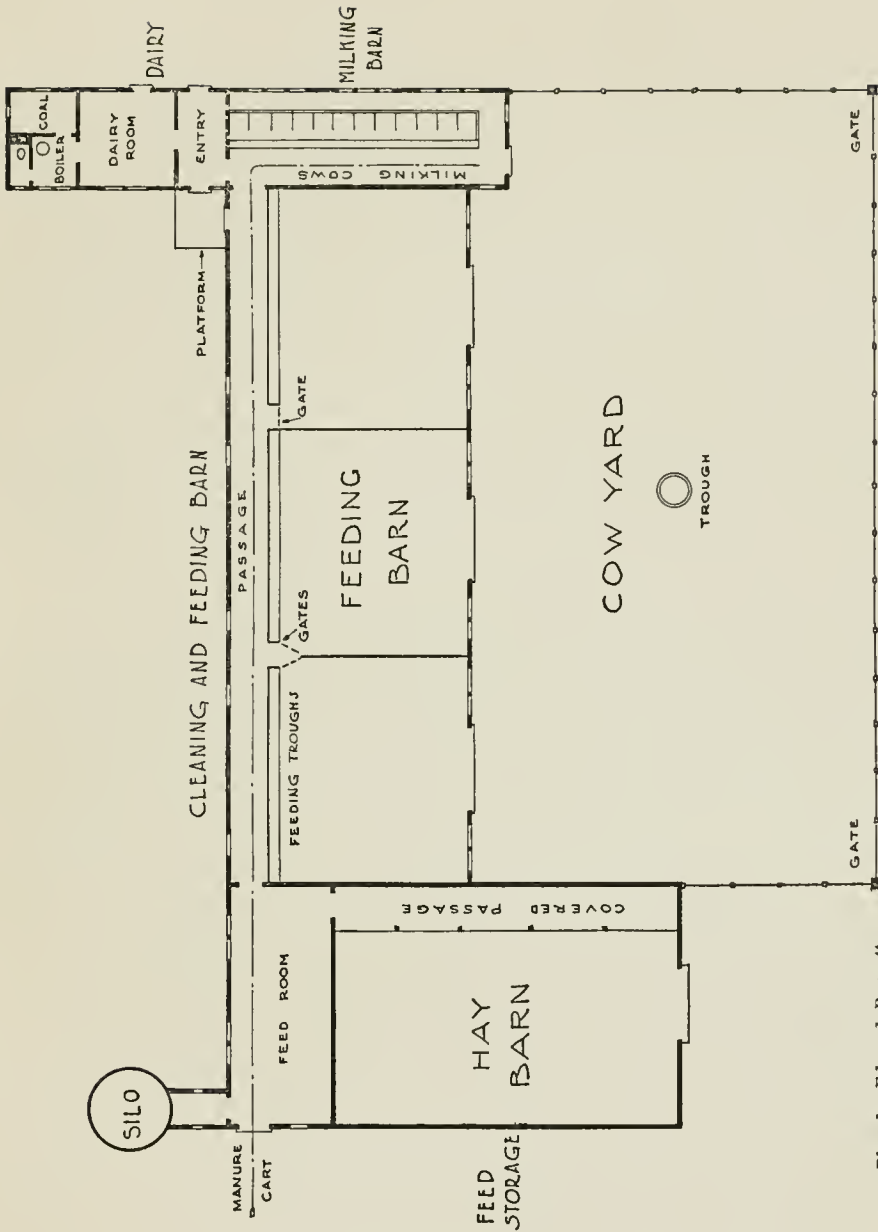

Plan by Edward Burnett

FIG. 29—PLAN SHOWING MILKING BARN AS A SEPARATE COMPARTMENT

The feeding, cleaning and milking of the cows in one building, causes certain restrictions in the manner and in the time of feeding, cleaning, and milking. The farmer's old-fashioned custom was to milk his cows while they were feeding. This is the worst possible way. The modern method is to remove the bedding and to hose down the walls and floors thoroughly; the cows then come into the barn for their cleaning, at least one hour before milking, so that the dust arising from this operation may have time to settle before the milking is begun. Assuming that the time required to groom the cows is thirty to forty minutes, twenty to thirty minutes must be allowed for the settling of the dust preparatory to milking. Not until after the last cow has been milked, and the milk taken to the dairy, should the herd be fed and bedded. As a usual thing, a rather better grade of milk is had at the afternoon milking than in the morning's milking, when the cows have been in the stable all night and the stable in consequence is less free from dust, although if the same time is allowed in the morning as in the afternoon for the settlement of dust after cleaning the cattle, there is no reason why the morning's milk should not equal the night's. In any event, the practice of morning milking before cleaning out the stable is a filthy one, and should not be tolerated under any circumstances. The cleanliness of the stable and dairy must be established by cleaning with water and the washing away of all infectious particles, and not by the use of disinfectants to destroy them. Milk possesses a peculiar power to absorb odors, and especially the

milking, and the tending of the herd should at all times go on gently and quietly. Yelling, kicking and chasing the animals, invariably done to a greater or less degree by the farmer's boy, is not only brutal and unnecessary, but it operates to the owner's distinct disadvantage in decreasing the milk flow.



THE BEST PLACE FOR THE ICE HOUSE IS THE WOODS. SKYLANDS FARM, STERLINGTON, N. Y.



THIS METHOD IS BETTER THAN THE USE OF DISINFECTANTS FOR CLEANING THE COW BARN

odors of carbolic acid, creoline, lysol, etc., and a stable properly kept does not need chemicals to insure its cleanliness.

It is usual, in providing help for large herds, to allow an average of ten to twelve cows to one milker, who has entire charge of grooming and milking them. This is over and above the help required in the dairy. In the smaller herd of ten cows or thereabouts, it will require a herdsman and a dairyman properly to provide for them. One competent man, however, can take care of three or four milking cows and their product.

At the risk of some repetition, we will now give suggestions for the proper care of animals at milking time and for a proper method of milking. These requirements, at first blush, may seem to be impractical, too arduous, or too intricate, all according to the humor or the moderation of mind of the individual who scans them. They represent, nevertheless, what should be insisted upon by the man with a herd of a dozen or more thoroughbred milking cows, who wants his milk produced in a thoroughly sanitary manner and is willing to provide everything in the way of building and equipment to have it so. In the smaller problem, excellent results may be obtained with simpler means, but real cleanliness, which is the direct object of all effort of administration, must be obtained by using the essence of these suggestions, perhaps in a modified form.

To commence with the cow: the hair on the flanks, the udder and adjacent parts, must be kept short by being clipped every two or three weeks, as the individual animal may require. This is necessary, as short hair harbors less dirt than long hair. With short hair the skin is more easily cleaned of dirt and dandruff—a particularly offensive thing by which milk is fre-

quently contaminated. Before each milking she must be well groomed with a good stiff brush, which in turn should be kept clean by the liberal use of the curry-comb; the latter, however, should not be used to any extent on the animal. After this operation she should be rubbed off with a fresh sterilized rubbing-cloth. The tail, udder and adjacent parts are then carefully washed with warm water and washing compound, and then dried; *finally* a fresh damp cloth is passed over the udder in order to allay any possible dust which may have settled after the cow has been groomed and rubbed off. The dampening of the udder is the last operation preceding the milking. To prevent the cows switching their tails while being milked, a wire tail-holder has been devised and is frequently used. This is not necessary and is sometimes undesirable. If the cow's tail has been properly cleaned and is kept so, there is no harm in allowing her the liberty of using it. While the cows are being cleaned, a rope is stretched under all the stanchions to prevent the animals from lying down. This is removed after the milking, and the accustomed liberty is again allowed. These details precede each milking.

The stables should be cleaned at least an hour before milking time. After the stalls and gutters have been hosed down, the floor and walls are sprayed with water and the gutters sterilized with boiling water. Even in the summer the doors and windows are best closed during milking, and the presence of feed in the stable should be absolutely forbidden at this time.

The men ought to be provided with two separate suits of overalls and to prevent the possible interchange of these they are better of different colors—the milking suit of white and

the barn suit of brown or blue. The barn suit is worn at all times except when the cows are being milked. The men should have the barn suits on when the cows are being groomed; that is while the currycomb, brush and rubbing-cloth are employed. When this part of the cow's toilet is completed, the men go to their wash room, where they take off the barn suit and hang it up in a closet, or locker, provided for that purpose. They then proceed to the wash room for a shower bath, especially necessary when the work has been in the field or about the ensilage. The hands must be washed very carefully in hot water with castile soap and a good stiff nail-brush. After the bath, sterilized suits and caps are put on, and with milk stools, pails, cloths and strainers, the men go to the barns. The stools should be of galvanized iron, and sterilized before each milking. The cloths are for the final dampening of the udder and teats. The pails used should be the covered pails having an 8-in. or 6-in. opening, and no strainer. It is well that all the doors from the barn to the milk room, when such a room at the barn is provided, be double-swing doors, without knobs or handles, and the man on going through must push them open with his elbow, and not with his hands; the hands of the milker must touch nothing which has not been rendered sterile from the time he commences milking until he has finished.

The operation of milking should be done carefully, quietly, and gently, without jerking or yanking; the hands, under no circumstances to be wet. The first stream of milk, usually sent into the gutter, is best milked into a cup. The place where the bacteria will form, if they form at all, is at the opening of the milk duct and the first few streams of milk must not be used. If, during the process of milking, anything

should get into the pail, the pail and milk must be discarded at once and a new one substituted. After each cow has been milked, the milker goes to the milk room at the barn, or where the contents of his pail can be weighed, the record is entered, and the milk poured into a 20-qt. can through a cheesecloth strainer; a fresh strainer being used for each pail of milk when the maximum of care is taken, but certainly a fresh strainer when any dirt or hair shows on the one in use. Particles of dirt left upon the strainer are simply dissolved by the pouring of warm milk over them. If the milking has been properly done the strainer should show no contamination even under the test of the bacteriologist. A strainer sufficiently contaminated so as to be detected by the naked eye must be removed at once. The strainer is, therefore, best arranged so as to be easily removed, and in such a way that a fresh one may be substituted without inconvenience. When the milker pours the milk from his pail into the 20-qt. can, he sets the pail on a galvanized iron rack provided for that purpose, and not on the floor. He then proceeds to wash his hands and dry them on a clean towel; this he must do before the milking of each cow. Ordinarily a 5-ft. roller towel will do for all milkers, but it must be fresh at each milking. The same pail is used by the milker for each one of his allotted number of cows, unless, as previously stated, a fly or some dirt—perhaps caused by a kicking cow—should get into it, when the pail and contents must be discarded. It might be interesting to know that if a fly were submerged for a few minutes in a cubic centimeter of milk, and the fluid were then examined under the microscope, it would not be unusual to have the plate record from 100,000 to 1,000,000 bacteria. As before stated, the only way to keep flies out of the building is to keep it clean and

dark; the blinds closed, except at milking time, and even then opened only wide enough to afford proper light for milking. Nothing attracts the flies more than dirt, so that all utensils of the cow barn should be kept clean and washed every day as regularly and as efficiently as the dairy utensils, although even so they should never be kept in the cow barn.

Everything which the milk touches should be sterilized. Everything which the milker touches from the time he dons his milking-suit until he has finished milking, should be sterilized. In fact, in the strictest sense the production of certified milk becomes a surgical operation, and the surgeon's antiseptic methods must be employed if a sterile product is to be obtained.

MILKING MACHINES

Although the purpose of this work is to go into those things only which influence the construction or plan of the buildings and must, therefore, be considered at its inception, yet we will touch briefly upon the milking machine and the vacuum cleaner, both of which may be operated readily by the same power.

The milking machine has hardly to do with the private plant, and it is pretty well established that a good milker is better than a good milking machine, if indeed such a thing as the latter has yet been devised. The disadvantage with the milking machine will always be in the trouble and care which are necessary to keep the mechanism clean, and the possibilities of its becoming dirty without being easily detected. In unclean surroundings the milking machine may prove an advantage, but in the clean barn careful methods of hand milking are the best.

In some of the strictly commercial herds the milking machine has been used for some time and here, where the difficulties of finding proper help are considerable, it has the advantage of requiring less men and, when expertly used, of consuming less time than ordinary methods. At present, it is a thing the advantages or disadvantages of which are largely a state of mind. To the man keen for all mechanical contrivances the milking machine will appeal, and through his careful and painstaking supervision it will accomplish satisfactory results, but it will not accomplish such results without such supervision.

VACUUM CLEANER

The vacuum cleaner, however, when perfected, ought to be a great advantage, as its principle is distinctly the right one—that of sucking in and conducting away the dust of cleaning instead of stirring it up and depositing over many things the dust that has accumulated on a few. The perfection of the vacuum cleaner is dependent only upon a proper tool for cleaning the animal and a better regulation of the force of the vacuum. Ordinarily this is too great and the process of cleaning by a vacuum has been an uncomfortable one for the cattle which they very properly resent. It will probably be found that some cows will be slow to accept and accustom themselves to it, though there is no reason why the young stock should not be trained to its use.

There is no doubt but that in a very short time, the vacuum cleaner will come into as general use in the cow barn as it has elsewhere. It has already been used to great advantage in the commercial horse stable, and one superintendent of such an establishment, enthusiastic over this method of cleaning his

animals, told the author that upon the breaking down of the apparatus, his horses were obliged to do without their vacuum bath for a fortnight and that as a consequence the difference in their condition was noticeable.

CHAPTER V

OTHER BUILDINGS OF THE FARM GROUP

THERE now remain in the farm barn group other buildings still to be considered and the largest of these is the hay barn, a very interesting structure for the architect, as it is the one which affords him the greatest scope in the way of architectural effect.

THE HAY BARN

There is no special detail important, except the construction which allows the handling of the hay by the hay fork to be done in the simplest possible manner. In the farmer's barn the framing was carried out with post and tie; this method, while satisfactory structurally, fills the entire interior of the barn with beams running in various directions, and makes the use of the hay fork difficult if not impossible. To overcome this the Western builder devised a framing which corresponds somewhat to a scissors truss, standing on one leg, and brings the support required for the ridgepole to the side of the structure and then directly down to the ground, leaving the space from the floor to the tie just below the ridge entirely unobstructed. The old and the new way of framing a hay barn may be very clearly contrasted in the plates facing p. 111. Fig. 30 shows a detail drawing of a truss suitable for hay barns ranging from 35 to 45 or 50 ft. in width; these trusses should be placed from 14 to 16 ft. on centers, and where no support-

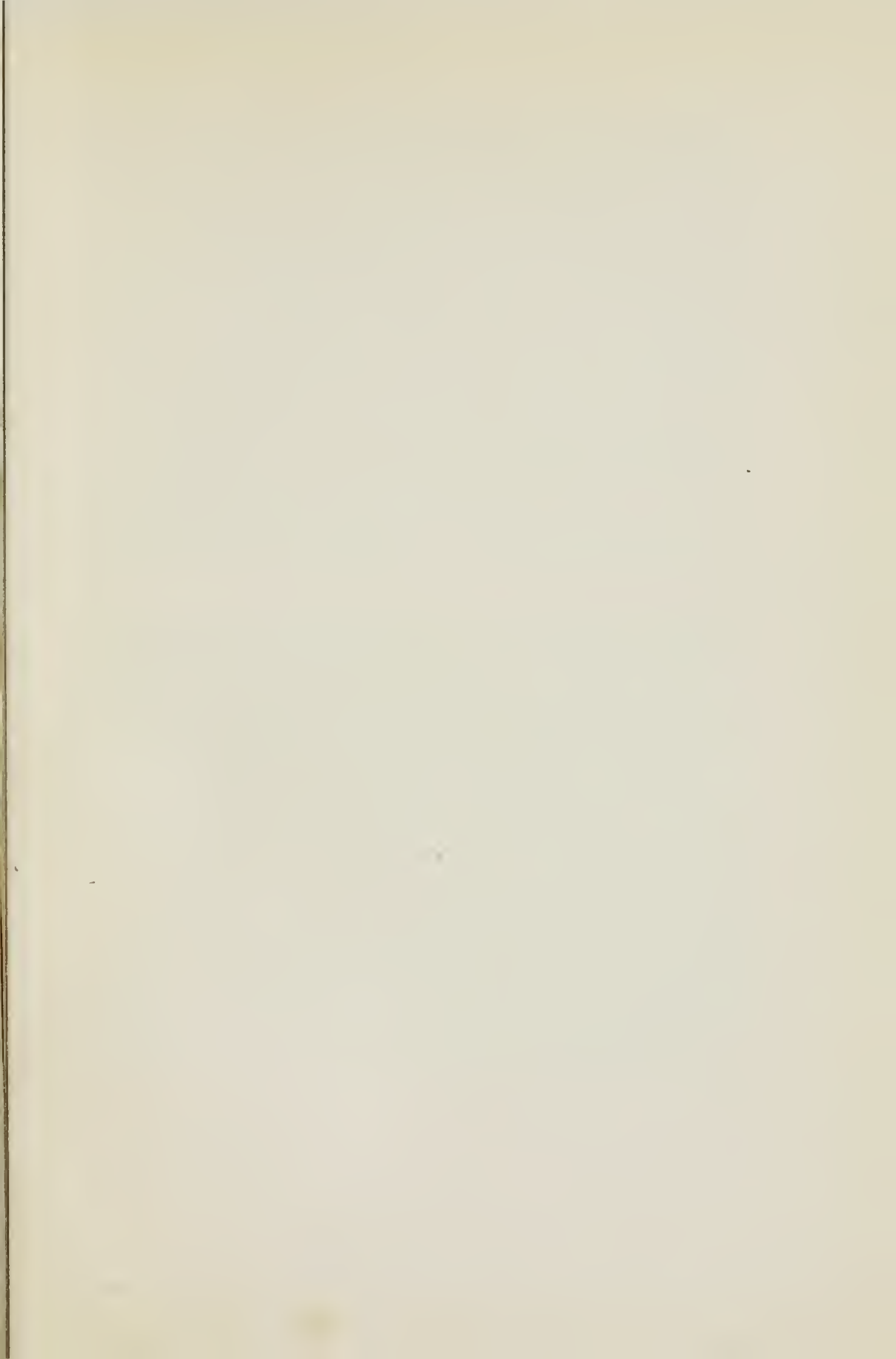



THE FARMER'S METHOD OF FRAMING THE HAY BARN



HAY BARN FRAMING AS SHOWN IN FIG. 30

six feet, and a door not smaller than 6 ft. wide and 8 ft. high is located just below it. The best way to arrange this door to open is to hang it on counter weights and slide it down (plate facing p. 76). Where it is arranged to drive into the hay barn at the side, it is an advantage to drive right on through; but in some locations, as on a hillside, where the grade will not permit this readily, the second door may be omitted and the hay wagons, after unloading, back out empty.

If, being on level ground, the situation of the farm buildings with regard to the hay fields is such that the hay will come from both sides of the hay barn, then both hay barn doors should be of adequate size to admit a wagon loaded with hay (12 ft. wide, 14 ft. high). If, however, all loaded hay can conveniently enter the hay barn from one direction, the entrance door must not be less than 14 ft. high, but the opposite door can be as low as 8 ft., 6 in. or 9 ft. in height, as the hay wagon though coming in loaded will go out empty. It is frequently an advantage to keep the door opposite the entrance door low, as it is sometimes desirable to use one side of the hay barn for sheds, store rooms, or winter box stalls, in which a high door could not be conveniently placed.

In larger plans, where the cows are in a wing at one end of the hay barn and the horses or young stock are in a wing at the other, access between them can best be had through the hay barn under a covered passage. This is no more than a rough ceiling supported on posts seven feet above the hay barn floor. The covered passage allows the hay to be stored above it and in smaller plans the top of the covered passage is frequently a good place to put the feed bins.

The proper ventilation of the hay barn is very necessary; the old idea of putting a central ventilator on the roof is fas-

cinating, but this and nothing else in a large barn is inadequate. Additional ventilation should be placed under the eaves, and not only in the sides but at the ends of the building as well. All louvers should have galvanized iron nettings over them to keep the birds out and batten doors to close them in winter. In computing the capacity of the hay barn it is usual to allow for each animal two tons of hay per annum, and for every ton of loose hay 500 cu. ft. of space.

If hay is bought, it is best purchased in bales. Baled hay takes up approximately one-third the room which loose hay does (150 cu. ft. per ton for baled hay as compared with the 500 cu. ft.), and it is frequently better to build a smaller hay barn and pay for baling the hay, even when hay is raised on the farm. Hay can be baled at the farm for \$1.15 a ton. Hay is more manageable in bales and it has the immense advantage of greatly reducing the fire risk. Baled hay will not burn, while there is scarcely anything more inflammable than hay in bulk. The use of baled hay in preference to loose hay is a matter which has not received the attention it most certainly deserves.

To procure protection for the cow yard and for the entire group of buildings, especially those containing the animals, the hay barn is most advantageously placed at the north. The natural disposition of the other buildings, as the various plans will clearly show, is to locate them to the south of the hay barn, the cow barn at one end, with horse stable, sheds, etc., at the other. This strict division between the work of the herdsman and the horseman must be enforced by the architect at every point, for the work of the one should go on quite apart and without interference from the work of the other.

THE FARM STABLES

The farm stables should include a general wagon room, where the better class of vehicle can be kept; the horse stable; a place for harness either in the stable or in a separate harness room; and for the farm machinery ample accommodations in the way of sheds, machinery room and tool room.

WAGON ROOM.—The wagon room is an enclosed room for an express wagon, farmer's buggy, or the better class of vehicle which requires more protection than is given by a shed. It is well to have a chimney in this room so that a stove may be set up in the winter. This is the only room in the horse department of the farm barn which need be heated. It should never be less than 24 ft. in depth, so that an average length vehicle can be driven in and unhitched comfortably after the door has been closed; 30 ft. in length is a minimum dimension. In larger plans a depth of 26 or 28 ft. is desirable. In planning for a number of vehicles it is usual to allow 7 ft. for the width of each wagon and 11 ft. for length. In close placing of many wagons it is possible to get the average width down to 6 ft., 6 in. per vehicle, and with a reasonable number of smaller traps to 6 ft. per vehicle. There should always be a place for the washing of wagons in the wagon room, preferably opposite the entrance, and there is nothing equal to the overhead washer. The wagon wash can be 10 or 12 ft. in width and its length had better be the entire width of the room. Its pitch to the bell trap should be at least $\frac{1}{4}$ in. to the foot.

HARNESS ROOM.—In the simpler class of stable it is quite possible to hang the farm harness in the wagon room,

but this should be done against the walls and not in cases. A movable harness rack may be used to advantage and is always useful for cleaning harness.

Where over eight or ten horses are provided for, a separate harness room is better, but here also the harness should be hung against the wall on large, heavy, galvanized iron hooks. If a harness room is included it is preferable to have the heat in here rather than in the general wagon room. Hot water, especially in the winter, is desirable for cleaning the harness and is frequently necessary for the proper care of the animals.

HORSE STABLE.—In the horse barn, as in the cow barn, all moldings or projections of any kind should be avoided. Horses may be arranged in double or single rows. The single row of stalls is very much better, as it enables one side of the stable to be thrown open to the sun and air. The great trouble with the double row of stalls is that it makes a dark stable and a very warm one in summertime, because it is necessary to keep the windows in front of the horses so high and so small that little light or ventilation can be had through them. The type of stabling which has a passage in front of the stalls, though requiring a larger building, is an excellent idea, giving more ventilation and comfort for the animal than any other method. It keeps the horses away from the light which frequently blinds them. A man with sensitive eyes can easily imagine the effect upon them were he tied in a stall before a window and in such a manner that he could not readily look away from it. This is precisely what happens to the horse in the average stall. The windows should, therefore, never be lower than 6 ft. 6 in. from the floor, and it is frequently desirable to paint the glass, or shade it by over-

hanging eaves. For the summer, nothing is better than the blinds put in in the same manner as described for the cow barn. This is the best possible method of keeping out the sun and letting in the air.

As in the cow stable, the manure trolley is far the best way to get the manure out of the building, and this manure trolley can be connected with the same system as the trolley for the cow barn. Various plans, which follow, will make this connection clear. The ventilation should be carried out on the same lines as indicated for the cow barn. It is sometimes difficult, however, to bring the outlet ventilating ducts below the ceiling, and the author in his practice has generally been content with taking the air out of the building from the ducts which stop at the ceiling, no side system of outlet ventilating being built. The windows (Fig. 31) are all that is required to let the air into the building, and these should be of the same type as called for in the cow barn, falling back into cheeks, with grills. Horses need less warmth in winter than cows, and it is a good thing to let the ceiling of the horse stable run up the rafters, raising the collar beams, and giving the horse stable a cubage or volume of from 1000 to 1500 cu. ft. of air per animal. The materials best used for the horse stable are those already suggested for the cow barn. Plastering is always to be preferred to wood sheathing; the stable floors should be made of concrete—never of wood; the stall posts and grills of iron. Care must be taken to have the floors drain properly, so that the water in hosing down will run off quickly into the gutters. The gutters should be shallow and their corners rounded, exactly the reverse of the cow stall gutter, and, above all, open. The covered gutter is hard to keep clean and consequently is generally dirty. The open gutter is the

WINDOWS IN HORSE STALLS

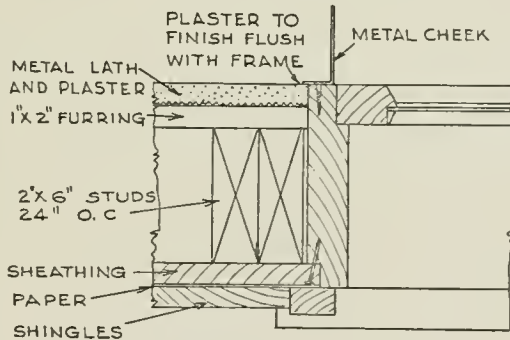
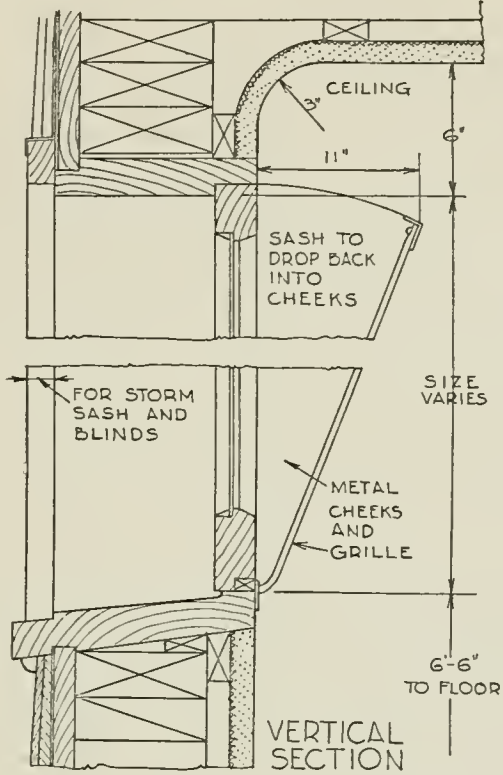

CROSS SECTION AT JAMB

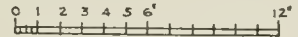

FIG. 31—DETAIL OF "BURNETT" WINDOWS FOR HORSE STALLS

only type to use for the farm barn. It should not be over 4 in. deep at the bell trap, the deepest point, and a pitch of $\frac{1}{8}$ in. to the foot is ample. It is not possible to pitch any open gutter sufficiently to have it drain, unless it is free from manure. The passageway back of the stalls is best marked off in 8-in. squares, which prevent the horses from slipping and are not as hard to keep clean as would appear. A drinking-trough, either in the stable or near it, is desirable.

STALLS.—The simplest possible stall partition is shown in the facing plate, which is merely a pole. This type of stall is very generally used throughout England, but it seems impossible to introduce it in this country. It is the best solution of the stall partition, as it allows the stalls to be made up easily and permits of almost unobstructed air circulation. Where the rigid stall division is put in there is nothing to equal the ventilating type of stall (Fig. 32) which has the partition planks separated by iron spools so that the air can pass between them. With the growing interest in concrete, stall partitions have been made solid in that material; while they look, and perhaps are, sanitary, they shut off all circulation of air and in the summer are intolerable. The stalls are usually 9 ft. in depth, though a shallower stall of 7 ft. answers all requirements and shows more of the horse. Stalls can vary from 4 ft. to 6 ft. in width, 5 ft. being the average, and there is nothing in the superstition that a horse will cast himself in a stall which is between 4 ft. and 5 ft. wide. Where a few horses are to be provided for, there is no stall equal to the one 6 ft. in width. In this the horse may be turned around and led out, which prevents him from kicking out the bedding as he does in a narrower stall from which he has to be backed out. A 6-ft. stall is also wide enough to allow cleaning or harness-



AN EXCELLENT TYPE OF SHED. FARM BUILDINGS FOR F. G. BOURNE,
ESQ., OAKDALE, L. I.

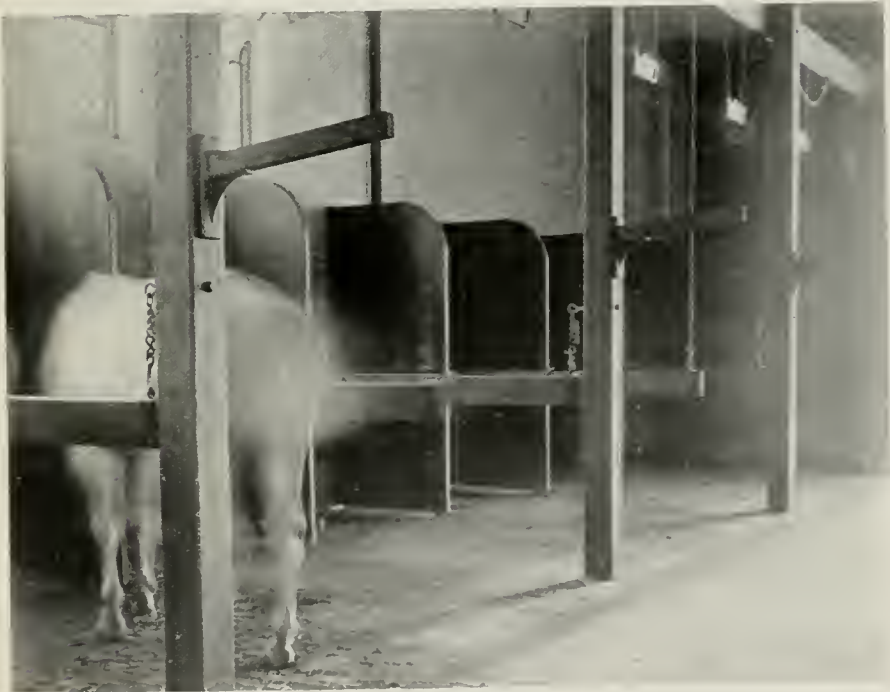

THE TYPE OF STALL USED FOR THE CAVALRY HORSES AT WEST
POINT

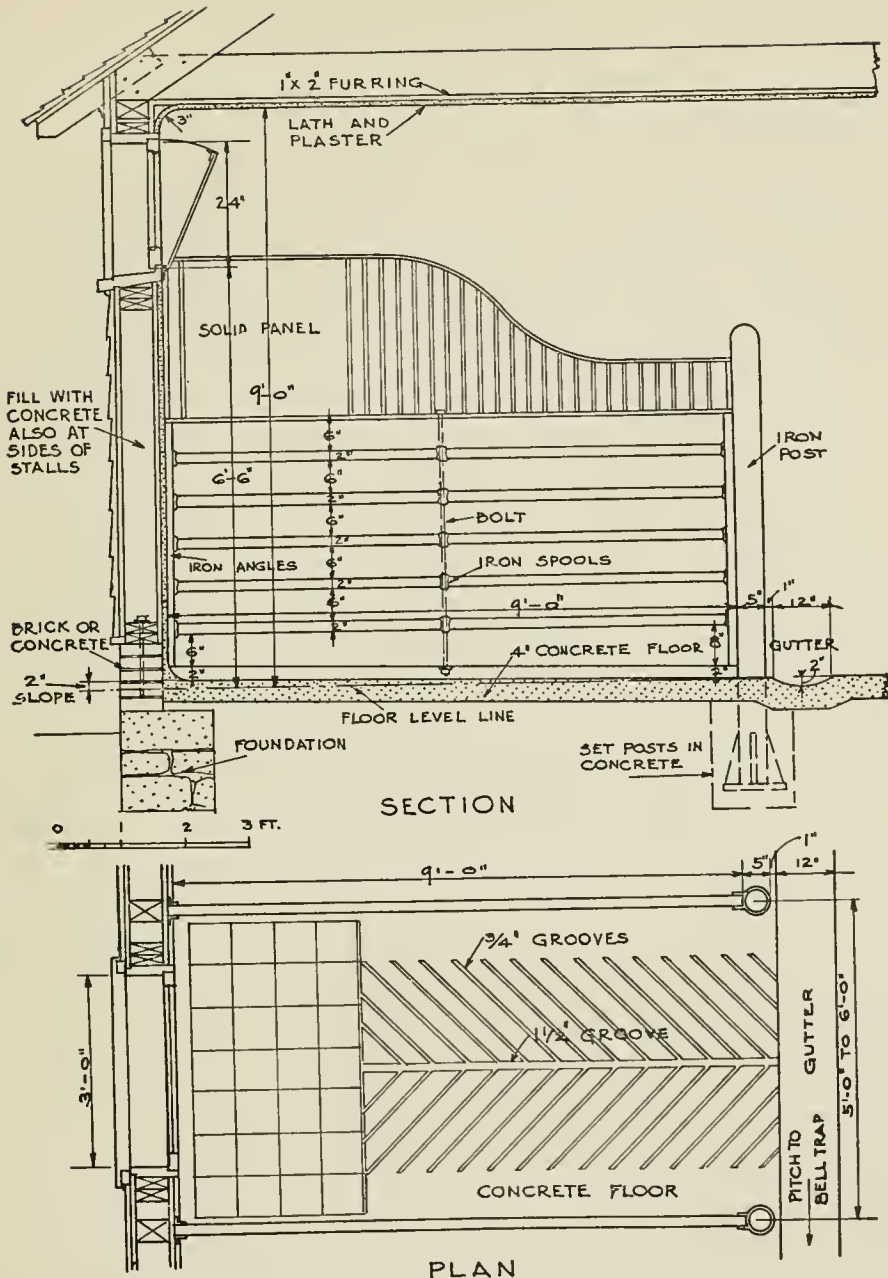

FIG. 32—DETAIL OF THE "BURNETT" STALL—THE BEST TYPE OF THE RIGID STALL PARTITION

ing the animal in it. Where many stalls are required, it is usual to make them 5 ft. in width; the 6-ft. stall unduly increasing the length of stabling, and in city stables the stalls are frequently reduced to 4 ft., 6 in. in width, but on the farm acreage the horse should be given more generous accommodations.

A stall is usually provided with two rings, one 3 ft., 6 in. above the floor, the other 5 ft. above the floor; the lower ring being used for tying the horse at night so that he can lie down, the upper one for the daytime. There are other methods of tying, one by means of a rope weighted at the end, another to a ring on a vertical traveler. As these give the horse a little more liberty, of which some animals like to take advantage, it is usually as well to arrange such details to suit the man who is going to attend to them.

Hay is best fed upon the floor, and no hay rack is necessary; the only fixture in the stall being the manger, and the roll rim type is the best. The farm horse usually does well on a concrete floor, but where there is a prejudice against it the wooden slat floor with an iron pan below is the best type of wood floor. The pans should be connected with the water system so that they can be flushed out; such stalls do have this advantage over the concrete—that the urine drains out of them more quickly and the bedding is drier in consequence.

In every horse stable it is well to have one or more box stalls; not less than 8x12 ft., and 10x12 ft. is better. Where there are ten or more horses it is a good idea to have some outdoor boxes with dirt floors, in fact all box stalls, whether inside or outside, are better with dirt floors. No drainage in these is necessary, except that the earth floor will have to be renewed occasionally according to the use of the stall. The ideal lo-

cation for the outside box stall is toward the south, and all box stalls should have Dutch doors to secure as much ventilation and sunlight as possible, and in single rows of outdoor boxes, Dutch doors on both sides are an advantage.

FEED ROOM.—A feed room for the horse stable is desirable. In small stables of three or four horses, where the hay is stored in the second story—though not over the animals—it is feasible to throw the bedding and the hay on the stable floor. It is better, however, to have this come down into a feed room, even though a small one, as it keeps the dust from the hay out of the stable. It is never well to store the hay over the horses, although bedding may be kept here, and a little patience in planning will generally discover some place for the horse's fodder where the fumes of his stable will not contaminate it. The practice of storing hay above and throwing it down into the stable through the ventilator is bad; if hay has to be kept over the horses it is better to have no communication between the hay loft above and the stable below.

SHEDS.—The shed is the place for the storage of all farm wagons, carts, extra tongues, shafts, and the various things, valueless and valuable, which accumulate in the practice of agriculture, and in any farm group, no matter how large, there is seldom shed room enough. A farm barn with too much shed room has never been designed. The shed should never be less than 24 ft. deep; the supports for the roof are best as few and as far apart as possible (plate facing p. 118) and ordinarily it costs but little more to construct a truss for the support of the roof than to put in posts in the usual way. Unobstructed shed room is greatly to be desired. The shed need not be over 9 ft. in height, in fact 8 ft. or 8 ft., 6 in. is usually all that is required under average conditions. It is frequently

convenient to arrange the shed on sloping ground, where a height of 7 ft. may be had at one end and 9 ft. at the other. It is inexpensive and often desirable to have a loft over the shed for general storage. This is always a dry place and also an accessible one. The hay barn can be made high enough to store the hay in a second story, leaving the space below for shed room, and in small farm groups this is an economical way of obtaining such space. This combination of hay barn and shed is especially adaptable to a sloping site, where the basement of the hay barn is put in the bank and used for the sheds, the hay going in above from the higher level. This idea is carried out in the plans shown of the farm barns at Oyster Bay and Westbury, L. I. In fact the shed provides excellent material for the architect, enabling him to spread his buildings out upon the ground and giving to them the long, low, sheltering lines which are always effective.

MACHINERY ROOM AND TOOL ROOM.—In connection with the shed and generally at one end of it, a convenient place is found for the storage of all the farm machinery. The mowing machine, rakes, tedders, etc., are used only for a short time during the summer, and when not in use are best kept under cover in an enclosed room, for the shed does not give them sufficient protection. The doors should be 8 ft. high and not less than 8 ft. wide, and for convenience in taking machinery out they are best as numerous as possible. The sliding door is the better type, but if the swing door is used it must swing out.

A concrete floor is desirable, though in a very sandy, dry location this may be omitted. Where superlative convenience is desired, a concrete floor can be put in the shed itself, though this is not at all usual and is almost the height of luxury. It

is a very decided aid, however, in keeping the shed sightly.

One more room is desirable and that is a room for the storage of tools: hoes, rakes, spades, shovels, etc., and is called a tool room. This may be a small room, but is convenient for general use, and in large establishments a general supply room is also necessary, where supplies are kept for distribution under the control of the superintendent. The tool room needs a concrete floor, some shelves—best made of slate—and for the shovels, rakes and hoes, plenty of pegs.

LEADERS.—It is very important that all the roofs of the farm group have the water conducted from them by gutters and leaders, and that it be not allowed to drop from the roof onto the ground. For this would wash out the yards and cause the earth around the buildings to be wet, when it is especially necessary to have it dry at all times. The leader drains may be led into broken stone pits or, where the grade permits, on to the ground, but always at a distance from the buildings. They should never be connected with the sewer system, nor with any drain lines from bell traps, as previously advised. In all yards the leaders are connected into cast iron pipe, extending 4 ft. above the ground and securely fastened to the building, as otherwise they are soon destroyed below this point by the cattle rubbing against them. In long sheds, where the supporting posts are usually some distance back from the eaves, it is unsatisfactory to carry the water from the gutters by running the leaders back and down the posts, such leaders in time invariably becoming injured or broken. These may be entirely done away with by crowning the eaves of the roof slightly in the center so that no leaders will be required except at the ends.

HARDWARE.—The most difficult and trying of all the

furnishings of the farm barn, in the author's experience at least, has been to find proper hardware. Very little of the stock hardware is practicable, and all hinges, bolts and locks must be of wrought metal and heavily made. The ordinary mortise locks for the large sliding doors are absolutely useless, as is all cast iron hardware, for it is invariably broken by rough usage. Swing doors, either single or in pairs, are

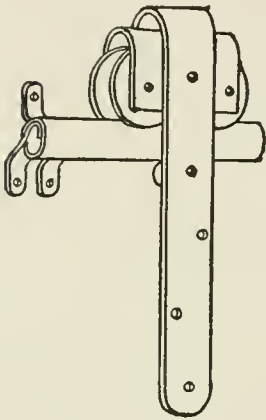

FIG. 33—"RELIABLE"
DOOR HANGER

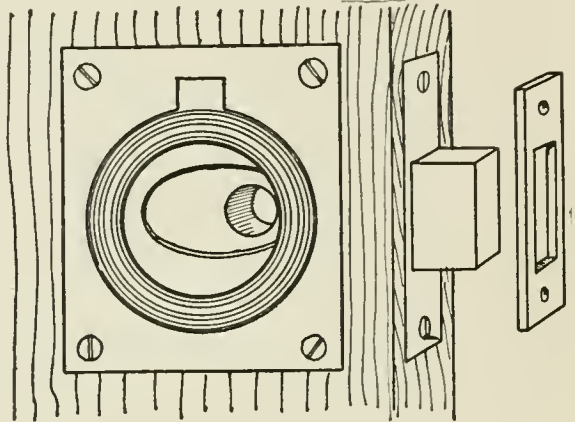

FIG. 34—FLUSH RING AND LOCK

best opened with the old-fashioned thumb latch. This is a very satisfactory fixture. All sliding doors are best arranged to fasten by a hook on the inside, and, if necessary to lock the door so that it can be opened from the outside, the only fastening is the padlock and hasp. The sliding door must have a roller on the inside at the striking jamb, and one on the outside at the opposite jamb, to work properly. See Fig. 20. A very good fixture is the Schouler door guide and weather strip, which is weatherproof and keeps the door straight and in position but it must be drained at the bottom or it is liable to freeze fast in winter.

The best way to lock up a barn is by an outside swing door, which must be properly located and not necessary for the animals' use. This door locks in the ordinary manner, either with a Yale or mortise lock. All the sliding doors can then be fastened from the inside with hooks, and need not be opened from the outside. The so-called "Reliable" hanger (Fig. 33), is the cheapest as it is the most sanitary hanger for stable work. Flush handles, are always necessary on *both sides* of a sliding door, whether the door is locked by a hasp on the outside or by a hook on the inside. These flush handles should always be provided to prevent opening the door with the hook or the hasp, for the continued opening of the door by either is hard to accomplish, and the strain breaks them in time. The Dutch doors should have hardware which will enable them to hook back flat against the outside wall, and the combination strap hinge with a movable butt is the best type of hinge for all swing doors. The only stock fixture which is useful is the flush ring and lock (Fig. 34), for fastening a swing stall door from the inside. For the Dutch door this should be placed on the lower half. If it is necessary to open the door from the outside a double cup can be had, though this will not lock the door; to do this a padlock and hasp are necessary. For second-story feed room doors, hay doors and the like, there is nothing equal to the old-fashioned swivel bar, hung in the center and falling into iron straps at each side, and when this is used the doors open in.

Fig. 35 shows the hardware necessary for the fastening of the windows in the cow barn, or in all buildings where the animals are housed. The windows not in the animals' quarters usually drop back on a chain with a hook on the end. This allows the sash to be easily removed by unhooking the chain

from the eye on the sash. These chains must be unusually strong, as the windows are heavy and a gale of wind will fre-

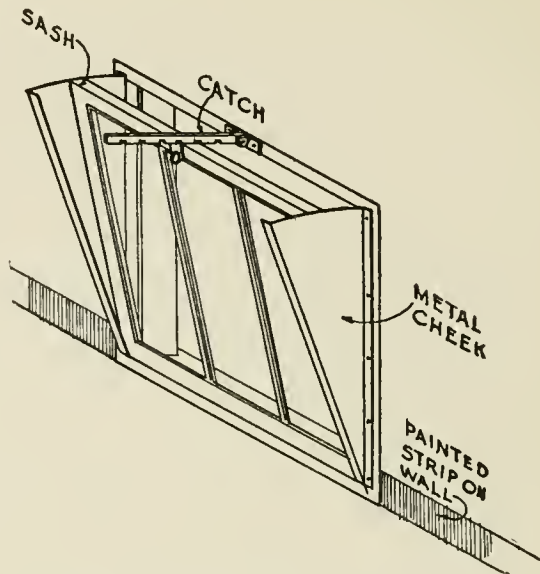

FIG. 35—WINDOW CHEEKS AND SASH FASTENER

quently blow them open and break the chain. Sash chain is of no use for this, and a chain the weight of the ordinary steel dog chain or halter chain is necessary.



A LOCATION IN THE FIELDS. FARM BUILDINGS FOR TRACY DOWS, ESQ., RHINEBECK, N. Y.

CHAPTER VI

PLANS OF FARM BARNNS

THE views which have been expressed in the foregoing chapters concerning the practical requirements of the farm barn, can probably best be illustrated by a brief discussion of the plans of buildings designed with those views in mind. The plans given are selected from many buildings built during a period of some ten or twelve years, but all will be found to be governed by the suggestions presented, though some to a greater degree than others. In one or two instances, where plans have failed in some particular, these have been given if by such illustration a point can be made clearer.

FARM BARNNS AT OYSTER BAY, L. I., N. Y.—Fig. 36

We will commence with an example which shows the plan of an extended group of buildings in an ideal location on the crest of a hill sloping to the south, with woods to the north, east and west. The setting is one offering unusual artistic possibilities, and to preserve these it was decided that the approach should be by an old lane which should go through the group, affording service at the rear and thus avoid cutting up with roads the attractive sweep of land that leads up to the buildings. This complicated the plan somewhat but an entirely practical result was obtained.

On the right of the lane was arranged the superintendent's house, with rooms for the superintendent on the first floor and

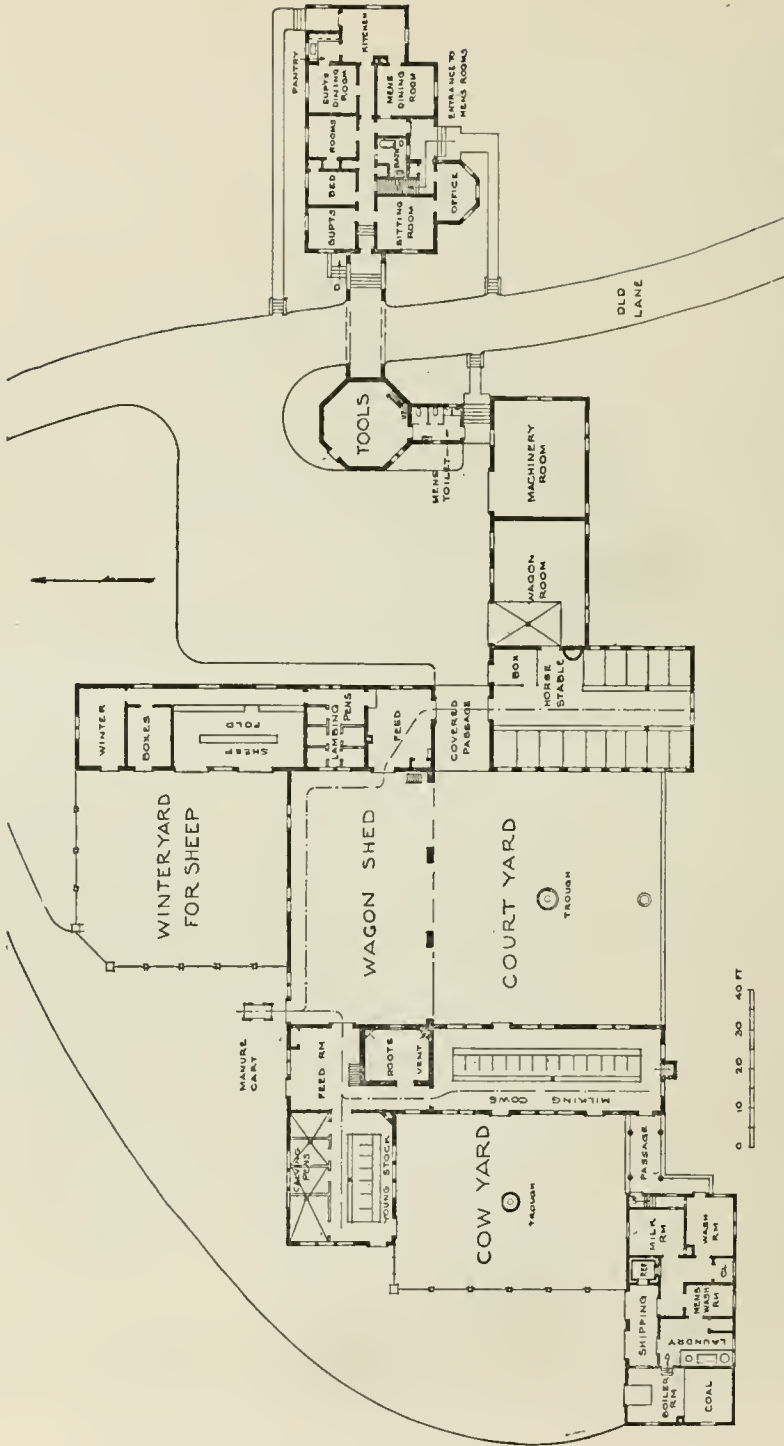

Atfred Hopkins, Architect

FIG. 36—PLAN OF FARM BUILDINGS AT OYSTER BAY, L. I., FOR LOUIS C. TIFFANY, ESQ.



GENERAL VIEW OF THE TIFFANY BUILDINGS, WHICH SUFFER GREATLY FROM LACK OF PLANTING



FARM BUILDINGS FOR LOUIS C. TIFFANY, ESQ., OYSTER BAY, L. I.

for the men above. It will be noted that the men have their separate entrance, and access to their quarters does not entail any loss of privacy in the home of the superintendent. A porch where the men can sit is provided under the pergola above the archway over the road. An octagonal tower was incorporated in the scheme to serve for a water tank and also for pigeons. The great desirability of entering all the buildings from the back made it necessary to drive between the horses' feed room and the horse stable. The manure track which goes across this passageway was devised so that it could be raised if necessary. The manure from the horses and the cows is conducted to the same general disposal place to the rear of the hay barn.

To gain additional height, so that the hay barn would dominate the group, the storage space for hay was raised to the second story, and shed room was obtained underneath; this is a very useful method of putting the hay over the shed, for it keeps the hay dry, makes a roomy shed, and is economical of space—always desirable where the buildings are cramped for room. To the left of the shed and between the young stock barn and milking cows, is located a root cellar, the floor of which is level with the ground. The outside walls were formed of three walls of 4-in. hollow building tile, laid 4 in. apart, the 4-in. spaces between the outside walls and the center wall being filled with sawdust. The roots have kept perfectly here, and there is an advantage in having the root cellar above ground, as it avoids the labor of bringing the roots from a lower level. The milk is brought across an open passage from the cow barn into a milk receiving room, in covered 20-qt. cans, where it can be poured either directly over the cooler in the milk room or into the separator in the wash room. The en-

trance to the dairy is from the north, and convenient to this entrance is located a refrigerating machine, which makes ice for general use, as well as providing cold storage for dairy purposes. The wash room and drying-room for the men have been planned as suggested in the chapter on the dairy, and the sterilizer between the wash room and milk room, as well as the various fixtures for each room, follow out the usual methods already described.

In these buildings was incorporated a sheepfold, as the owner wanted to enhance by a flock of sheep the effect of a picturesque lawn which slopes from the house down to the water of Long Island Sound. Their quarters have been placed as far as possible from the buildings, as sheep, being timid creatures, do better by themselves. When sheep are to be raised in large numbers it is well not to include the sheepfold in the general farm barn plan.

The design of the buildings was carried out to meet the owner's very decided views as to architectural lines, and it was the intention to grow vines over the walls and to contrast with the long level top lines varying masses of planting at their base. Though the buildings have been built for three or four years, none of the planting has been done, which proves in this instance what has been established in many others, that the planting should be taken up as carefully and methodically as the planning of the building.

FARM BARNs AT RHINEBECK, N. Y.—Fig. 37

In this plan it will be noticed that the milking cows are between the young stock and the feed room, an arrangement that did not work out satisfactorily. Another error on the practical side is having the horse manure tracked through the



EFFECTIVE PLANTING ABOUT THE DOWS FARM BUILDINGS



FARM BUILDINGS FOR TRACY DOWS, ESQ., RHINEBECK, N. Y.



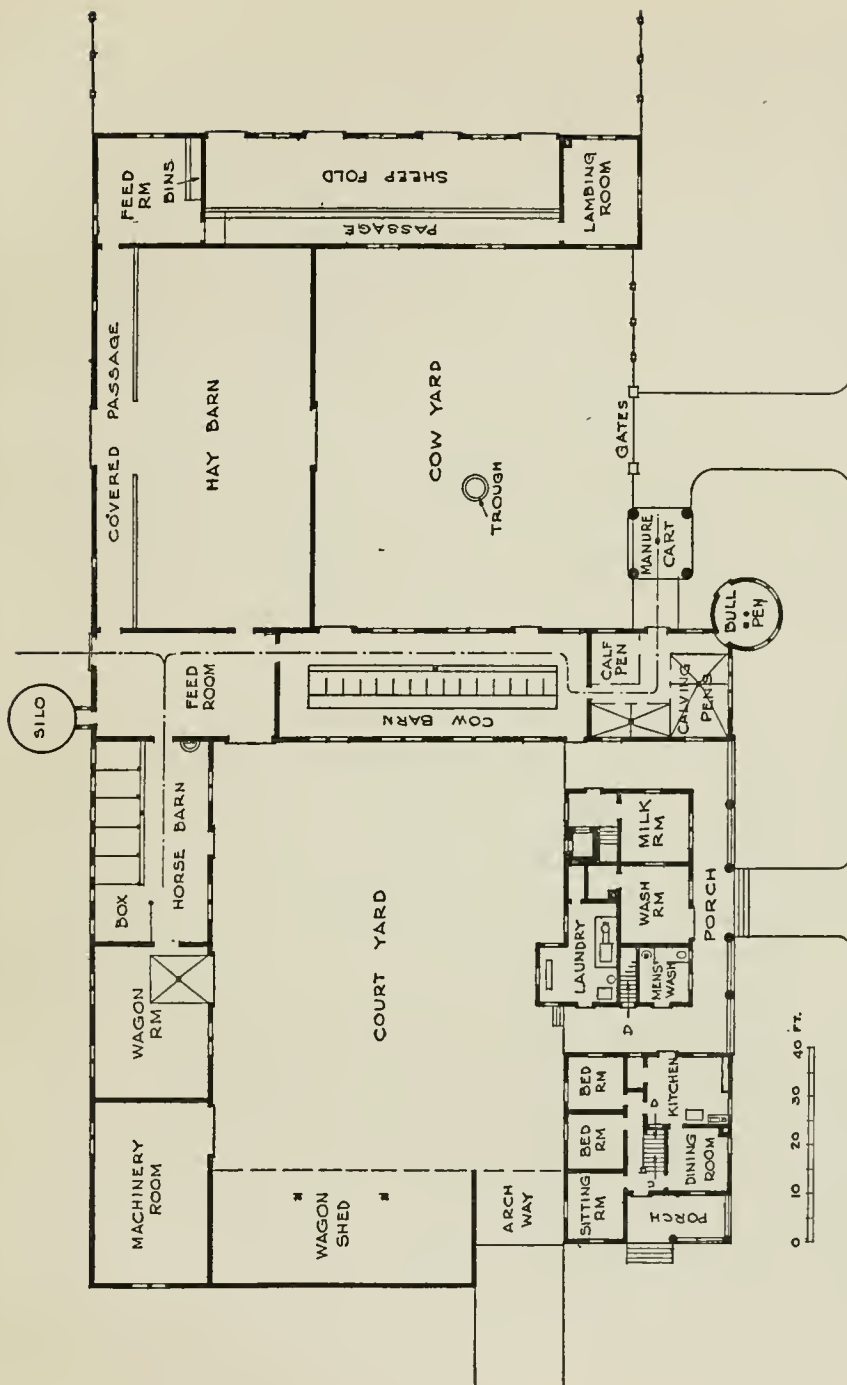

Alfred Hopkins, Architect
 FIG. 37—PLAN OF FARM BUILDINGS AT RHINEBECK, N. Y., FOR TRACY DOWNS, ESQ.

cow barn; this was changed later by taking the manure out at the north, which overcame this objection, but it can be easily seen from this plan how undesirable it is to have to go through the cow barn to get to the young stock barn. The young stock quarters were located to get the benefit of the southern exposure, and also in order that they might be heated economically from the dairy. While these two considerations are an advantage to the young stock barn, and seemed sufficient reason at the time for carrying out the plan as shown, yet they do not offset the disadvantage of having to go through the milking cow barn to feed and clean up in the young stock barn.

The dairy, completely surrounded by fresh air, connects conveniently with the cow barn on the one side and the farmer's cottage on the other. The plan of putting the dairy so near the farmer's cottage is objected to by some who have decided notions on sanitary milk production. They argue that any contagious disease contracted by an inmate of the house brings this contagion entirely too near the source of the milk supply. This is good theory and good practice for large commercial plants, where the strictest supervision against disease is necessary and where the help is greater in numbers and scattering and transient in character, but for the private estate there is a great advantage in having the dairyman live near his work.

The courtyard, formed by the open sheds, machinery room and wagon room, makes a complete enclosure, useful in itself and always interesting architecturally.

FARM BARNS AT SCARSBORO, N. Y.—Fig. 38

Here almost the same general conditions prevail. The requirements of the owner demanded storage room for hay, a



DAIRYMAN'S COTTAGE—RESTFUL ROOF LINES AND PROPER PLANTING



A BEAUTIFUL ENVIRONMENT FOR THE FARM GROUP. FARM BUILDINGS FOR JAMES SPEYER, ESQ., SCARBORO, N. Y.

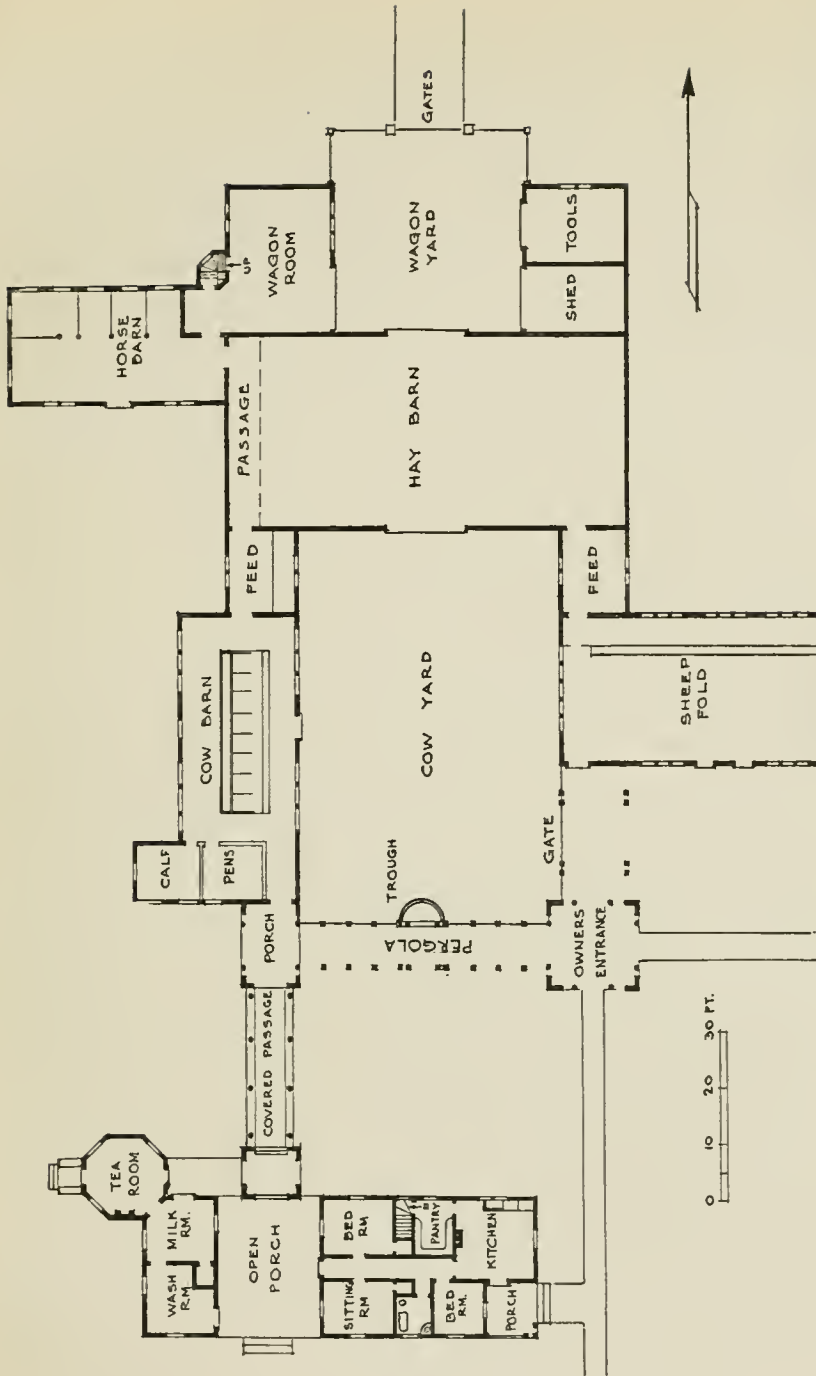

FIG. 38—PLAN OF FARM BUILDINGS AT SCARBORO, N. Y., FOR JAMES SPEYER, ESQ. Alfred Hopkins, Architect

few farm horses, wagons, quarters for the men, cow barn, sheep cote, a small dairy and quarters for the dairyman. These buildings have been carried out in the so-called half-timber style, in order to harmonize with the residence, built in that manner, but the vertical timber work has been sparingly used, and plain stucco walls were left to form a background for the planting relied on to give the principal artistic effect; this has thrived so well as to fully justify all expectations. There is nothing which enhances the effect of any building as proper landscape treatment, and this is especially so with the farm barn, whose many angles and corners afford effective and protected places for vines and shrubs, and whose growth in a few years will many times repay, in pleasure, their initial cost.

This plan was designed before the manure trolley came into general use and, consequently, was not so devised as to enable this mode of cleaning the stable to be properly installed. The scheme is a small one, so far as actual requirements go, and under such conditions the scientific methods of making certified milk can be less rigidly carried out. The calf pens here are shown in the milking barn, as they appear also in some other plans for the smaller establishment, but when these were designed it was the practice to put the young stock in the milking barn so that in winter they might receive the warmth of the other animals. For the large plants especially, but for smaller ones as well, this is distinctly bad practice, as the dust from the calf pens is considerable and should be kept out of the milking stable.

The buildings we are describing have a delightful situation on the banks of the Hudson, beneath large trees, and every effort was made to have them attractive and interesting from



DRINKING-TROUGH IN THE COW YARD



THE PERGOLA FROM THE SOUTH. FARM BUILDINGS FOR JAMES SPEYER, ESQ., SCARBORO, N. Y.

every viewpoint. The pergola across the south, and enclosing that end of the cow yard, is an effective piece of landscape work which nature makes more beautiful each year, as the clematis and wistaria grow more and more luxuriant in leaf and flower. The covered passage, connecting the farmer's cottage to the cow barn with its white columns, gives a touch of lightness to the whole composition, besides being entirely useful in connecting the farmer's home with his place of work. The dairy comes on the other side of an open porch, and consists of two rooms—the wash room with its red tile floor, and the dairy room tiled throughout in white—with the refrigerator between; this being filled from the open porch. Adjoining the milk room is a tea room, the principal entrance of which is from the outside, and it has been attractively furnished. The frieze and ceiling are made up of old Dutch paintings of the farm animals—chickens, pigs, horses, cows, guinea-hens, and while this arrangement is by no means scientific and might excite the ridicule of a bacteriologist who has specialized on milk, yet this whole group of buildings is a distinct feature of the beautiful estate to which it belongs and it affords comfortable and practical housing for the sheep, the horses, the cows, and the men who tend them.

FARM BARN S AT WESTBURY, L. I., N. Y.—Fig. 39

These plans again show a similar problem, though a different solution; the requirements demanding accommodations for eight cows, with two calf pens, seven farm horses, and four box stalls for riding-horses, together with a tool room, machinery room and a dairy, with the quarters for the dairyman above. It must be observed that wherever the dairyman's quarters are placed in the dairy building they are so arranged

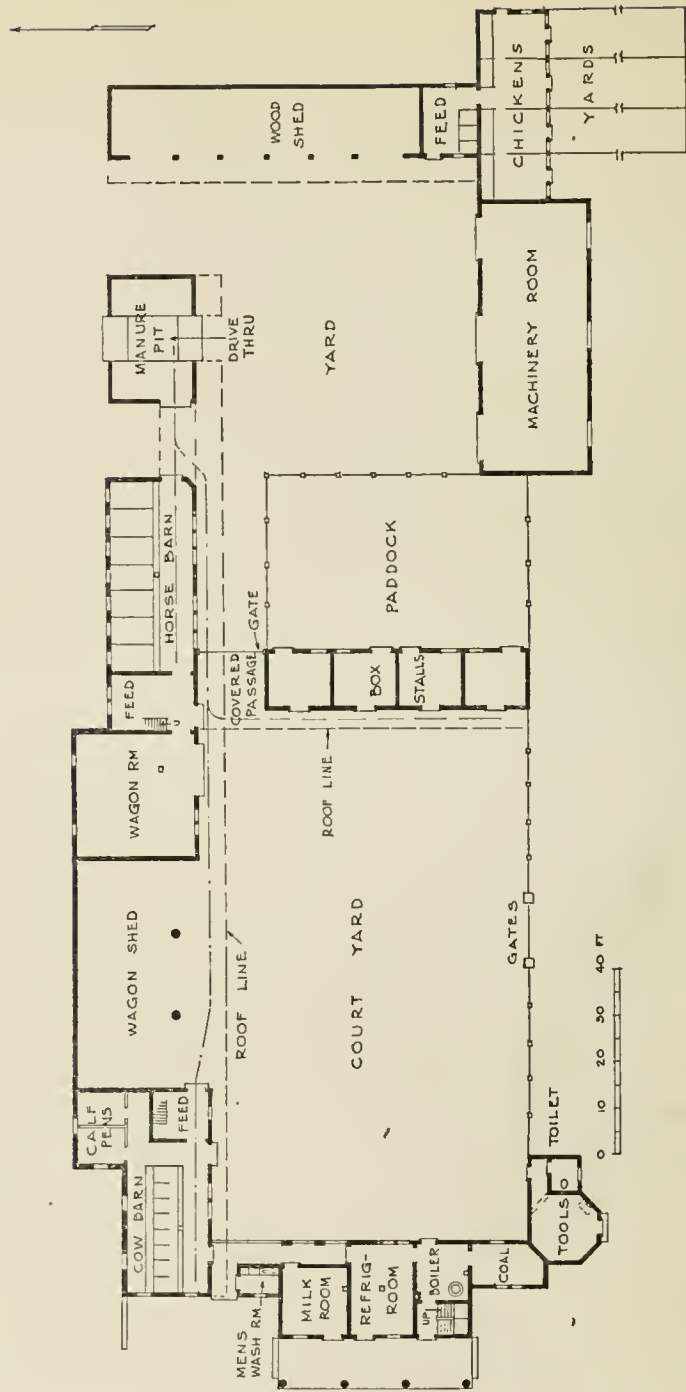

FIG. 89—PLAN OF FARM BUILDINGS AT WESTBURY, L. I. FOR CHARLES STEELE, ESQ. Alfred Hopkins, Architect



BUILDINGS IN STUCCO WITH SHINGLE ROOFS. SOME DECIDUOUS SHRUBS WOULD IMPROVE THE PLANTING



FARM BUILDINGS FOR CHARLES STEELE, ESQ., WESTBURY, L. I.

that separate access is had to them, and in no instance is it necessary for the dairyman to go through or even near the dairy rooms to get to his home. Nothing is more undesirable than to have the dairyman care for the milk and its utensils in his kitchen, which is a custom not unusual with the farmer. No matter how small the problem, a separate place for milk and milk things is absolutely necessary.

In this plan it will be noted that the manure trolley from the cow barn runs on the outside of the building under projecting and protecting eaves, and is there conducted into the same manure pit that answers for the horse stable. The conditions of this estate seemed to demand the construction of a manure pit near the farm barn, where the manure from the coach stable, not included in this plan, is also deposited. As a general rule it is bad practice to put a permanent manure pit near enough to the buildings to trolley to it. It makes a breeding place for flies and is a thing that has no place near the farm buildings.

The hay barn is here elevated, with the sheds below, an arrangement of hay storage and shed room seen in Figs. 36 and 46. In this problem, however, the difference in the grade was such that the hay barn was placed in the bank and filled from the higher level, the sheds and the other buildings being entered and used from a lower level. The owner wanted to incorporate his chickens in the farm barn group, and they have been located near the machinery room with runs to the south. A woodshed, running to the north, completes the enclosure of a yard intended for a general rubbish yard. On every country place, and especially on an estate of this character, it is necessary to have some sort of enclosure for rubbish, packing-boxes, leaves, barrels, and the multitude of

things which accumulate and belong to those vague incumbrances that ought to be thrown away or destroyed but never are, being saved in the hope that at some future time they may prove useful. The yard here shown was designed to provide a place for such things, and it is not only screened from the rest of the estate but from the farm barns as well.

FARM BARNs AT GREENWICH, CONN.—Fig. 40

These buildings are built on a site sloping to the west, where field stone was convenient and plentiful, and it was decided to use some stonework in the buildings but to make the main construction of wood and to cover this with split or rived cypress shingles. This combination is always a suitable one, as the surface of the shingle is secured by cleaving it from the log in the same manner as the stone is plugged and feathered from the boulder. In addition to the cow barn and dairy, the plan provides four standing-stalls for farm horses and four large box stalls for riding-horses, with Dutch doors opening into the paddock, to the south. To simplify the plan a separate wing was not given to the riding-horses, but these have been included in the farm stable. Above the carriage room are the quarters for the men, who have a second-story porch—an interesting feature in the design of the building and a thoughtful addition to the comfort of the quarters for the farm hands. Access to the men's room is had directly from the carriage room, or from an outside carriage wash through the octagonal stone tower. An outside carriage wash is a great advantage in the summer months, for on hot days it is much cooler to wash the carriages here than in the buildings, especially where the back wall of the carriage room is a closed one, as it is in this instance.



INTERESTING GROUPING AND GOOD ROOF LINES. RIVED SHINGLES FOR WALLS, WITH PORTION OF BUILDINGS OF FIELD STONE. THIS PHOTOGRAPH WAS TAKEN BEFORE THE PLANTING WAS STARTED



FARM BUILDINGS FOR H. F. FISHER, ESQ., GREENWICH, CONN.

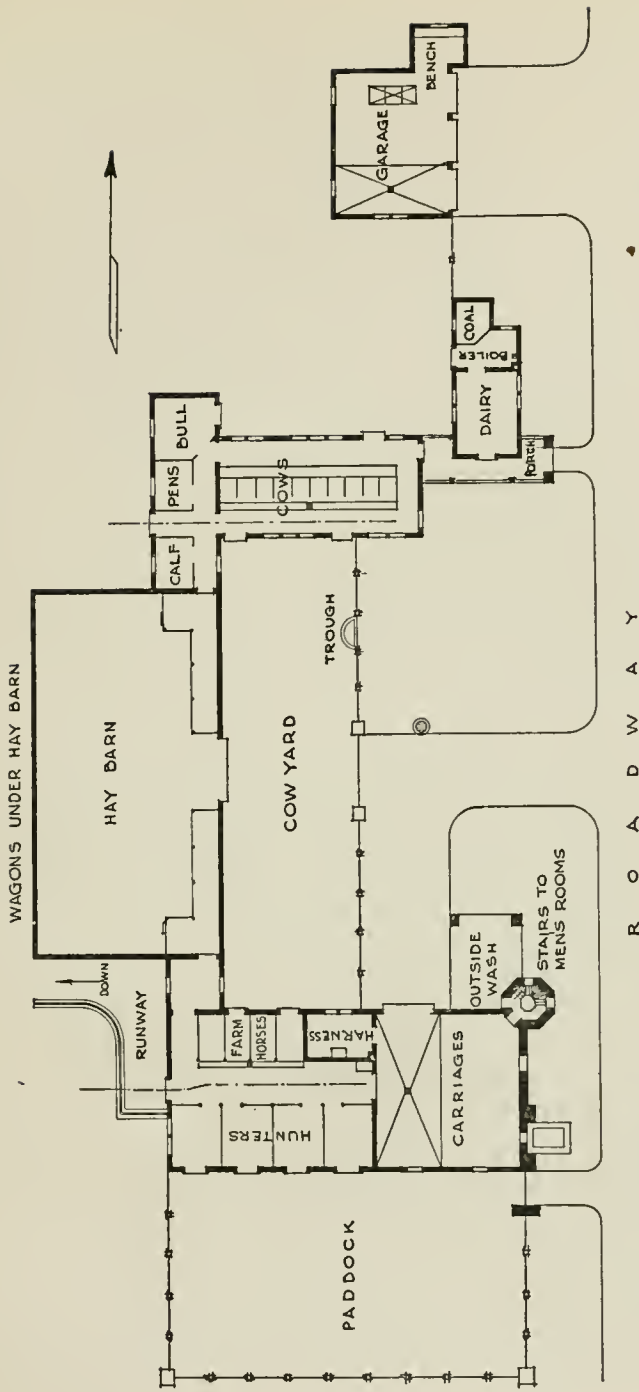

Alfred Hopkins, Architect

FIG. 40—PLAN OF FARM BUILDINGS AT GREENWICH, CONN., FOR H. J. FISHER, ESQ.

In this plan the young stock are separated from the cows. The conditions of the site were such that it seemed impracticable to trolley the horse manure and the cow manure to the same place. The grade is low at the back of the buildings, so that the manure trolley from the cow and horse barn was run directly through the end of the building and emptied into carts below. This kept the horse manure and cow manure separate, which is sometimes preferred. Underneath the hay barn is a large cellar or shed entered from the rear at a lower level.

The dairy is separated from the cow barn in the usual manner, and the entrance to the cow barn and dairy is through the small porch from the roadway. It will be observed that the dairy has been pushed to one side, so that access to the cow barn is *past* it and not through it. A garage is incorporated in the scheme, and an additional yard for the bull is formed between the cow barn, dairy and garage.

FARM BARN AT STERLINGTON, N. Y.—Fig. 41

These buildings are built of reënforced concrete throughout, and are as fireproof and sanitary as it is possible to make them. Here again the dairyman lives over his dairy, but both his quarters and the dairy are separated from the farm buildings by open air. Fig. 41 gives the plan of the main and original building at the lower level, providing for ten milking cows, three calf pens, bull pen, feed room, root cellar and the usual rooms for the dairy, including a milk receiving room, connected to the cow barn by a covered passage. The requirements of this group increased, so that eventually a young stock stable was built to the north, and a silo added, the same track being utilized for the manure and the ensilage. A separate



THE LARGE POSTS WITH RAFTERS ABOVE SUPPORT THE MANURE TROLLEY



SHELTER AT NORTH END OF COW YARD. FARM BUILDINGS FOR FRANCIS LYNDE STETSON, ESQ., STERLINGTON, N. Y.

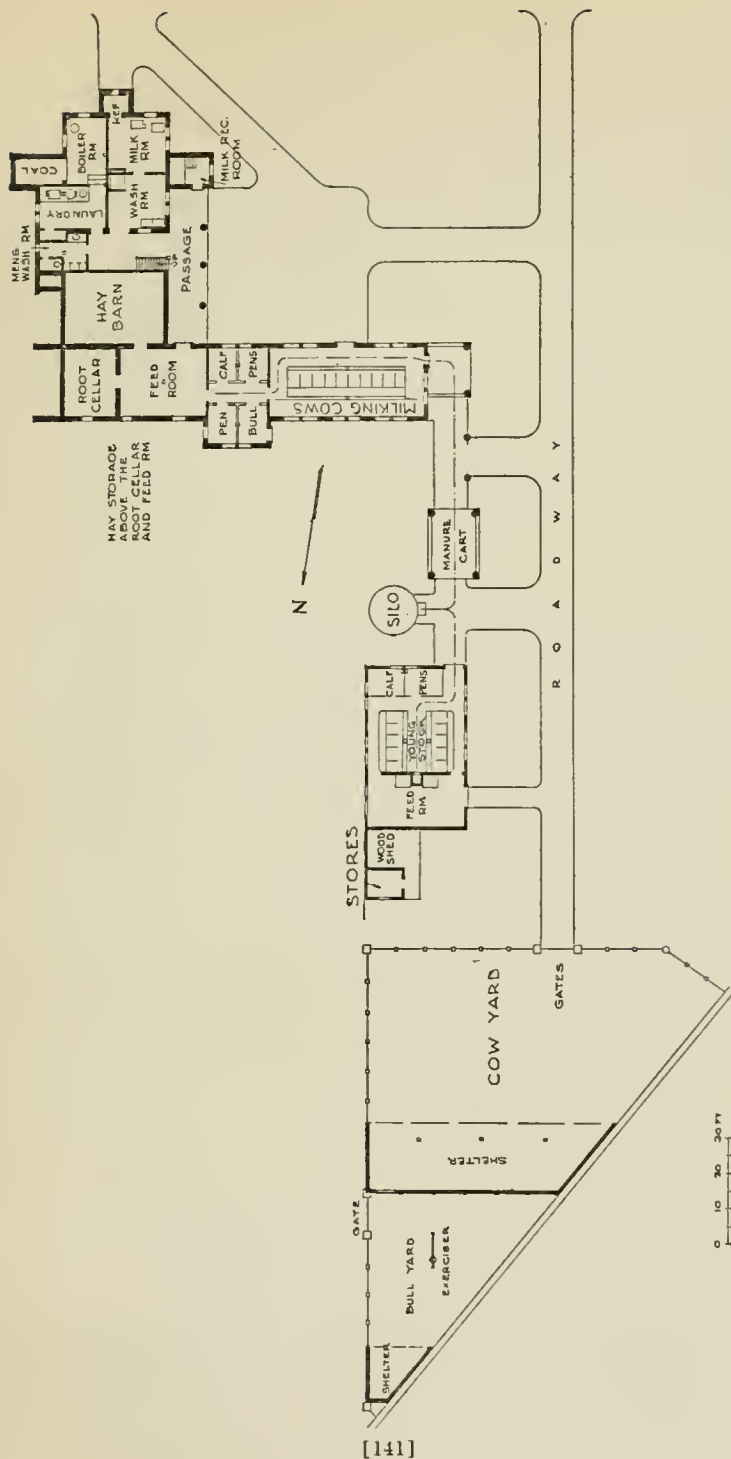

Alfred Hopkins, Architect

FIG. 41—PLAN OF FARM BUILDINGS AT STERLINGTON, N. Y., FOR FRANCIS LYNDE STETSON, ESQ.

cow yard was continued to the north, which is well protected by a high stone wall to the northwest and woods and trees to the northeast, but to increase the natural shelter at the north, a shed was erected. This separation of the cow yard from the immediate vicinity of the milking barn is greatly to be desired, as has been set forth in a previous paragraph. Nothing could be more convenient or more desirable than the location of the yard here shown, and such a disposition of the exercising place for the cattle must be had if ideal conditions at the milking barn are to be obtained. The bull has his separate yard beyond, with an exerciser and a shed for inclement weather.

The milk is taken from the cow barn into the milk receiving room where, from a raised platform, it is run over either the separator or the cooler; the milk, going in from a higher level, is conducted to either by gravity. This platform is also utilized for the ice-water tank which furnishes the cold water for the cooler. When the milk is poured over the cooler from a similar outside milk receiving room, there should be a glazed opening in the partition so that the man on the outside can see that the apparatus within is ready to receive the milk. A ship's porthole is heavily glazed and does well for this purpose. In this dairy the high-pressure sterilizer was installed, a laundry and drying-closet, and everything done to make the buildings as sanitary, fireproof, and as nearly perfect as possible.

When it became necessary to increase the quarters for the young stock and dry stock and to give up the cow barn to milking cows exclusively, it was decided to build the young stock stable completely away from the old building, and the young stock barn was, therefore, given its present location. It



AN INTERESTING GROUPING IN WHICH THE ROOF LINES WERE SOFTENED BY ROUNDING THE HIPS AND RIDGES, FARM BUILDINGS FOR S. T. PETERS, ESQ., ISLIP, L. I.

is conveniently placed for the silo and the manure shelter, and though in a plan for only ten milking cows this isolation of the young stock in an entirely separate building is unusual, yet here it has worked out well in every way.

To the north of the young stock is a woodshed and a room for storage—always a useful thing in connection with the farm barn for keeping extra utensils, and especially the storm sash, blinds, etc., which during some months in the year are out of season and need a proper and accessible storage place.

FARM BARN S AT ISLIP, L. I., N. Y.—Fig. 42

This shows another variant of the usual conditions obtaining on the private estate. The plans call for ten milking cows, seven dry stock and young stock, and the usual calf pens. Here the hay has been stored above the young stock and the feed room, and below the latter is a root cellar. As before stated, it is frequently convenient to place the hay in the second story and, when circumstances make it necessary to store it over the animals, it is preferably placed over the young stock rather than over the milking cows. In order to economize somewhat in the size of the buildings—for the site allotted to the farm barns was a little cramped, though a fine one—this placing of the hay seemed advisable. The storage place, however, was not a general storage but held only a four-months' supply brought from the main hay barn some distance away.

In this plan the bull has been located a little distance from the rest of the cattle and his pen, extended in height, is used as a dove-cote and clock tower.

The dairy has been reduced to the simplest possible solution of the problem, the owner wishing to carry on his dairy-

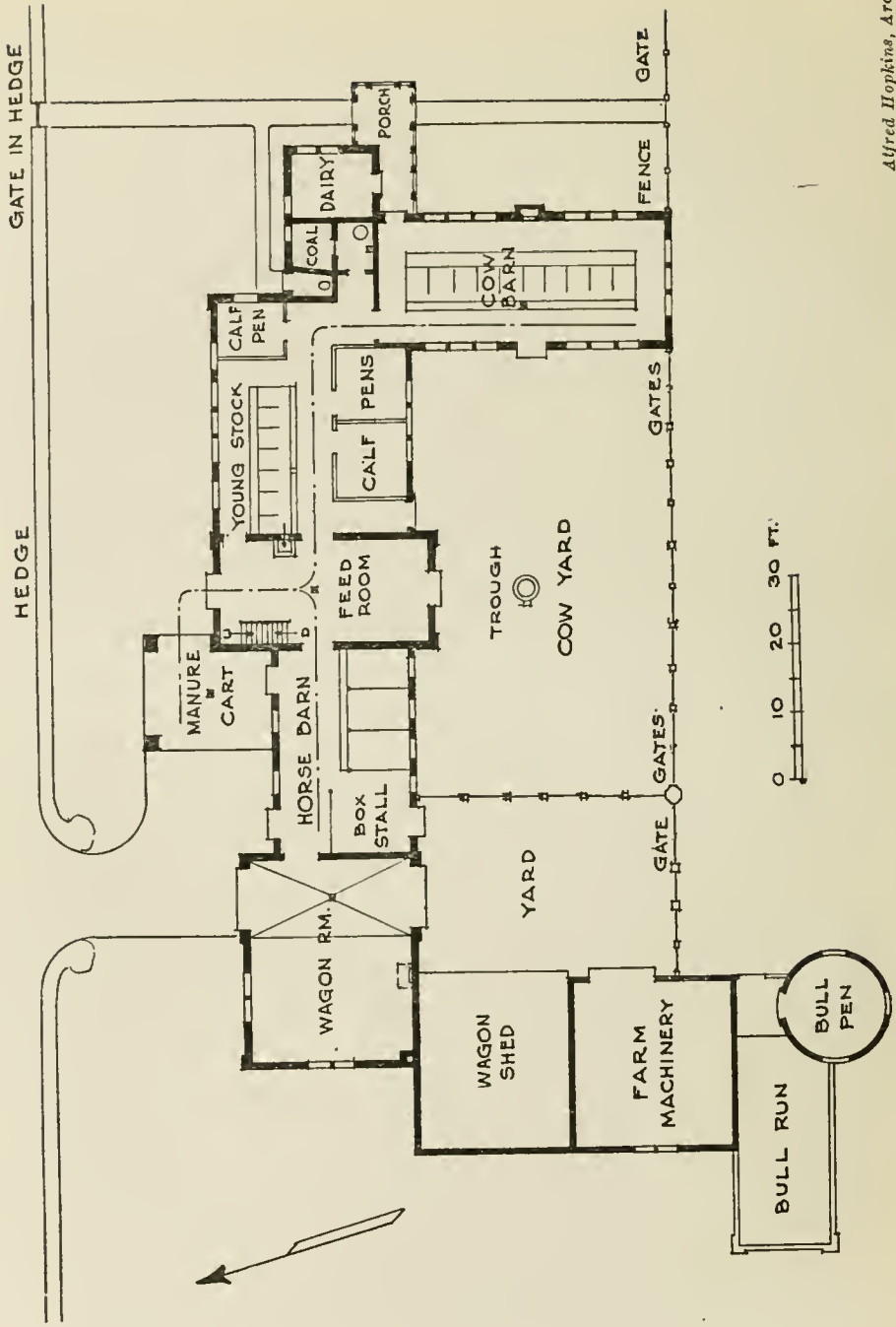

FIG. 42—PLAN OF FARM BUILDINGS AT ISLIP, L. I., FOR S. T. PETERS, ESQ.

Alfred Hopkins, Architect



VIEW OF THE PETERS BUILDINGS FROM THE NORTH—A BEAUTIFUL ENVIRONMENT



THE DAIRY. FARM BUILDINGS FOR S. T. PETERS, ESQ., ISLIP, L. I.

ing in the old-fashioned way, depending on soapsuds and sunshine for cleanliness, a pleasant though an unscientific view; and a lattice in front of the dairy was devised, with hooks and pegs, that the cans and pails might be hung in the sun upon them.

It will be noticed that the closet for the men has an outside entrance only. This was put in at the pronounced wish of the owner, but it would have been better in the author's judgment had this entrance been through the boiler room. Here it would have been less likely to freeze and more easily inspected. This feature of the farm barn is a trying one, as such places are usually dirty and should be kept as far away from milk production as possible. On the other hand, they want to be sufficiently convenient so that proper inspection of them is to be had at all times, and it is a mistake to locate the toilet where it cannot have easy and constant supervision. The location given to it in Fig. 42 is a good one, and though it is placed nearer the dairy, it is yet sufficiently removed. Here has been provided a steam and water connection that cleanliness may be assured with live steam, and during many inspections the result has never revealed anything objectionable. This feature is not, after all, so much a question of locality as of uncompromising cleanliness—a matter of administration rather than planning.

The manure trolley goes to the manure shelter through the feed room, and, as before stated, there is no objection to this disposition of it.

The buildings depend for their architectural effectiveness entirely on their roof lines and in the simple but effective way in which the structure is spread over the ground.

FARM BARNS AT MORRISTOWN, N. J.—Fig. 43

This was the first farm barn building which came to the author's architectural practice, and was built in 1900, when the principles of sanitary milk were not so definitely established as they are at the present day. Before the idea of the

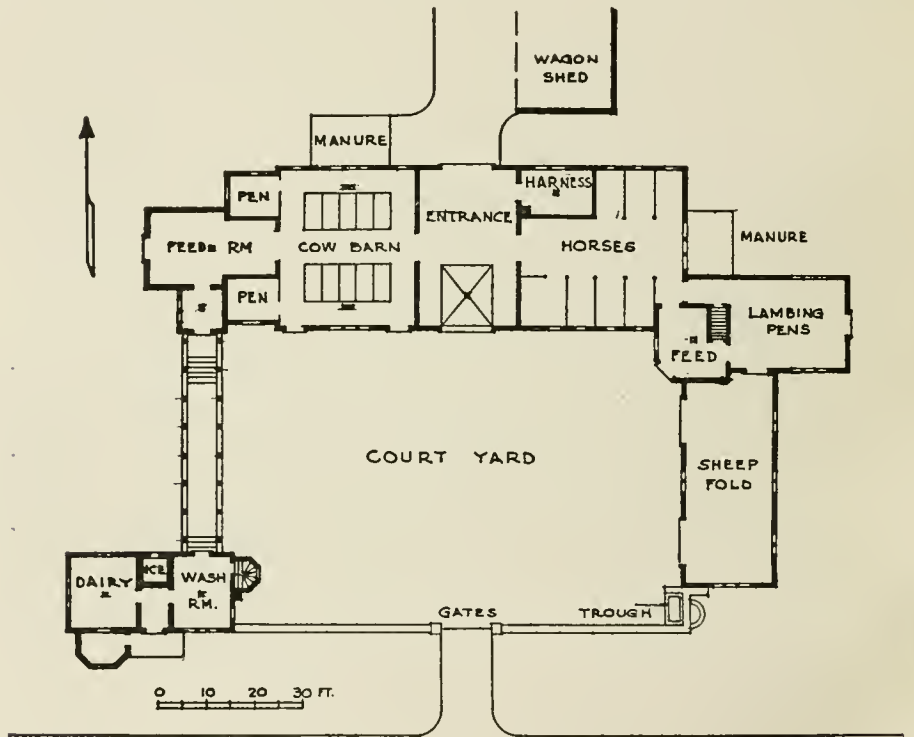

Alfred Hopkins, Architect

FIG. 43—PLAN OF FARM BUILDINGS AT MORRISTOWN, N. J., FOR O. H. KAHN, ESQ.

manure carrier, it was thought that the only way to dispose of manure was to throw it into a manure pit, which for convenience was always placed next to the building. From the



A GOOD GROUPING BUT SADLY IN-NEED OF PLANTING. FARM BUILDINGS FOR CHARLES E. RUSHMORE, ESQ., WOODBURY FALLS, N. Y.



A BEAUTIFUL SETTING FOR THE FARM BARN. FARM BUILDINGS FOR O. H. KAHN, ESQ., MORRISTOWN, N. J.

present point of view, this is to be avoided, but it was the custom at that time.

The sheep pen, opening into the general courtyard, was eventually given up and used for young stock. Another fault in the plan, though not a serious one, is that the milk has to be carried through the feed room to go to the dairy. It may be asked by the thoughtful reader, why this plan should be published by way of illustrating a modern farm barn, to which the architect replies that it was a first and a serious effort to make sightly the habitation of the farm animal, and he simply pleads a parent's affection for his first child. The exterior of the buildings is perhaps carried out in a less simple manner than usual, but is not out of character with the rest of the estate, as the house is of the Casino type as designed by the distinguished architects of the Ponce de Leon Hotel, at St. Augustine, Fla.

FARM BARN S AT WOODBURY FALLS, N. Y.—Fig. 44.

This plan shows the smallest requirements yet noted, providing for only three stalls for farm horses, two box stalls for riding-horses, three cows, a calf pen, together with a dairy, farmhouse and sheds.

The dairy has been devised in the form of an octagon, and originally had an exterior stairway up to a man's room above. This arrangement formed a tower which greatly increased the architectural effect of the buildings, but was discarded for sanitary reasons, as it was felt that the man's room was too near the dairy. Probably this objection is more sentimental than real. The scheme is so laid out that the farmer can go under cover directly into the cow barn and horse stable; the dairy being separated from the cow stable in the usual way.

In the plan it will be noted that the door to the dairy is shown opposite the door to the cow barn. This is as it should be. During the construction of the building the owner felt that odors, germs, or something vague but contaminating, might blow from the cow barn and the yard into the dairy, and the

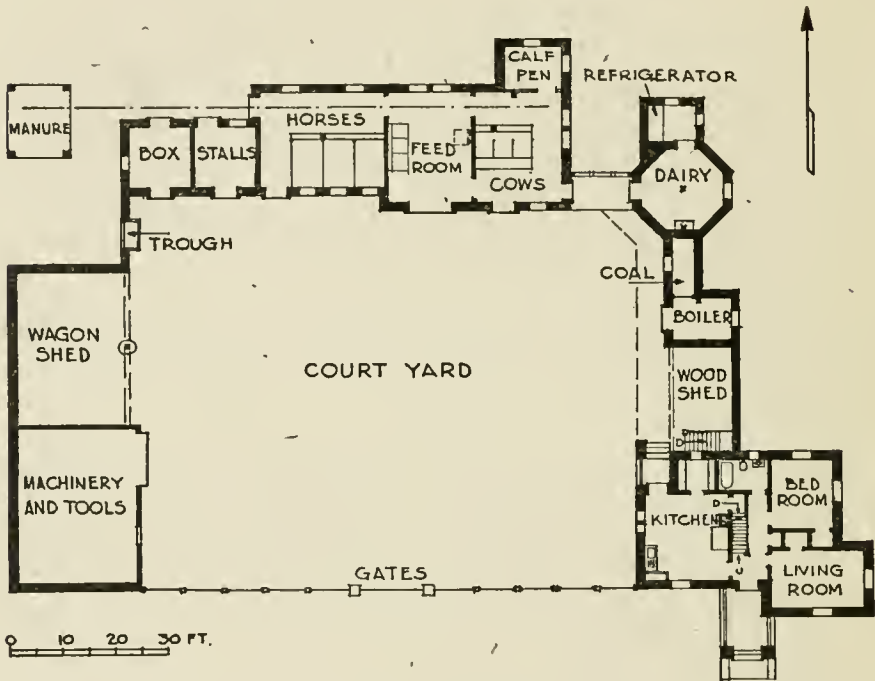

Alfred Hopkins, Architect

FIG. 44—PLAN OF FARM BUILDINGS AT WOODBURY FALLS, N. Y., FOR CHARLES E. RUSHMORE, ESQ.

dairy door was changed to the opposite side of the octagon. This is, perhaps, a natural view of the layman, but an erroneous one, as the milk has been already exposed to contamination *in* the cow barn and the injury, if done at all, has been done before it reaches the dairy. Though it is no great hardship, in a small plan of this character, to carry the milk

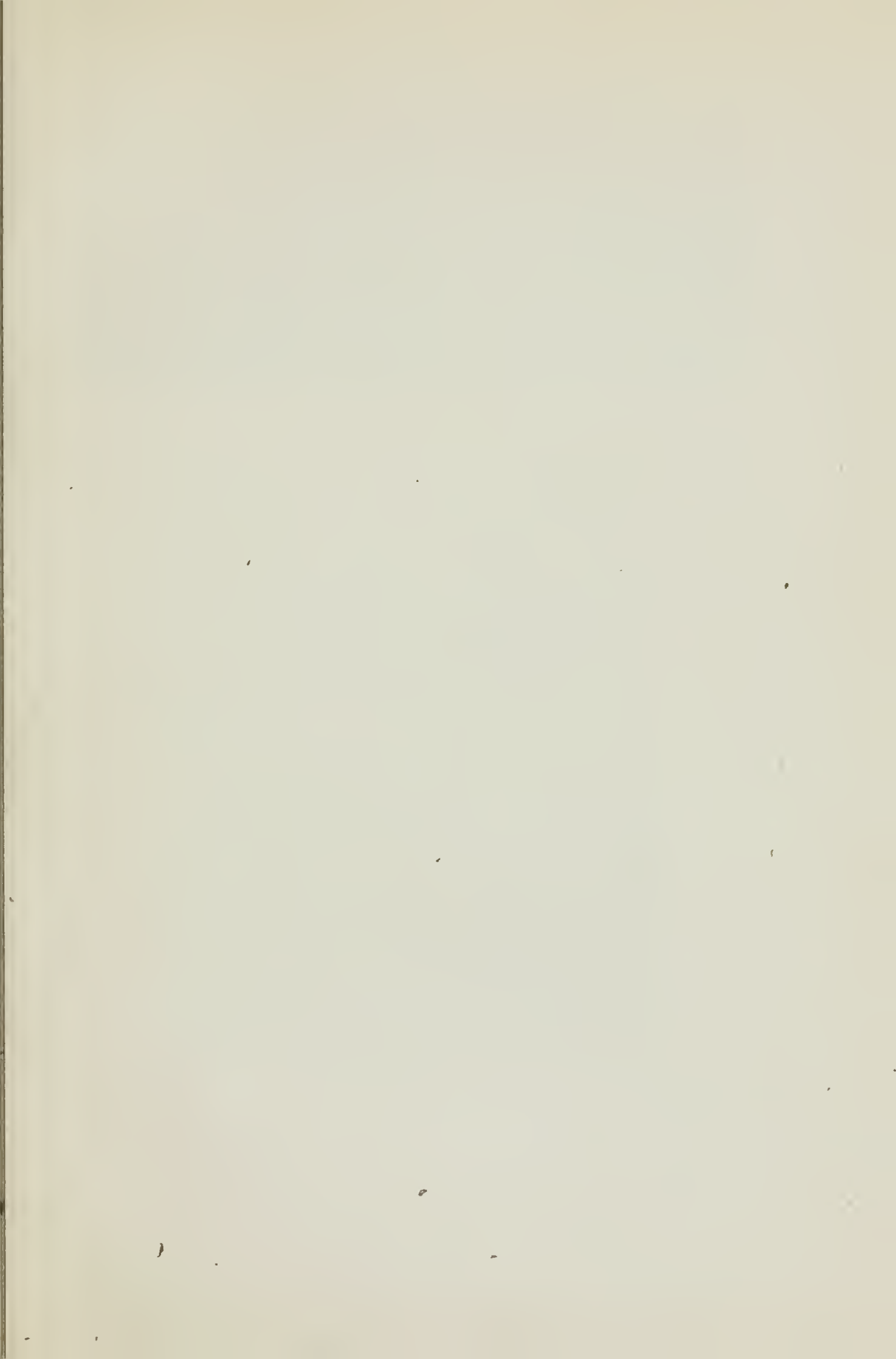



GENERAL VIEW



THE TOWER. FARM BUILDINGS FOR J. E. DAVIS,
ESQ., BROOKVILLE, L. I.

a few feet further around to the opposite side of the octagon, yet this detail is gone into as a reply to arguments which the architect of the farm barn frequently has to meet; and in any plan, no matter how small, it must be remembered that the work of the milk goes on twice a day for every day in the year, and the ease and convenience with which this can be done should not be sacrificed for any reasons other than good ones.

Adjoining the dairy is the heater room, and between it and the farmer's house is the woodshed. The bay is kept over the feed room and cow barn, which, in a small barn of this character, is the simplest way of caring for it.

The buildings are carried out in stone, which adapts itself well to a covering of vines and foliage, but, unfortunately, the planting was left until some future time, which in the author's experience at least, seldom if ever arrives.

FARM BARN S AT BROOKVILLE, L. I., N. Y.—Fig. 45

The plan here shown involves some decidedly new features. The requirements of the estate seemed to call imperatively for all farm buildings to be incorporated in the one group, and the owner, an accomplished horseman, insisted that his riding-horses and his dogs be placed where he could see and be with them conveniently. It must be confessed that the question of combining a dog-house and a dairy was gone into with some trepidation, and while the kennels look very near the dairy on the plan, yet the working out of it was more satisfactory than was anticipated. Were the author to solve this problem again, he would endeavor in some way to house the howl with the hound, so that it could not be heard out of the kennels. There is no data yet as to whether or not milk can

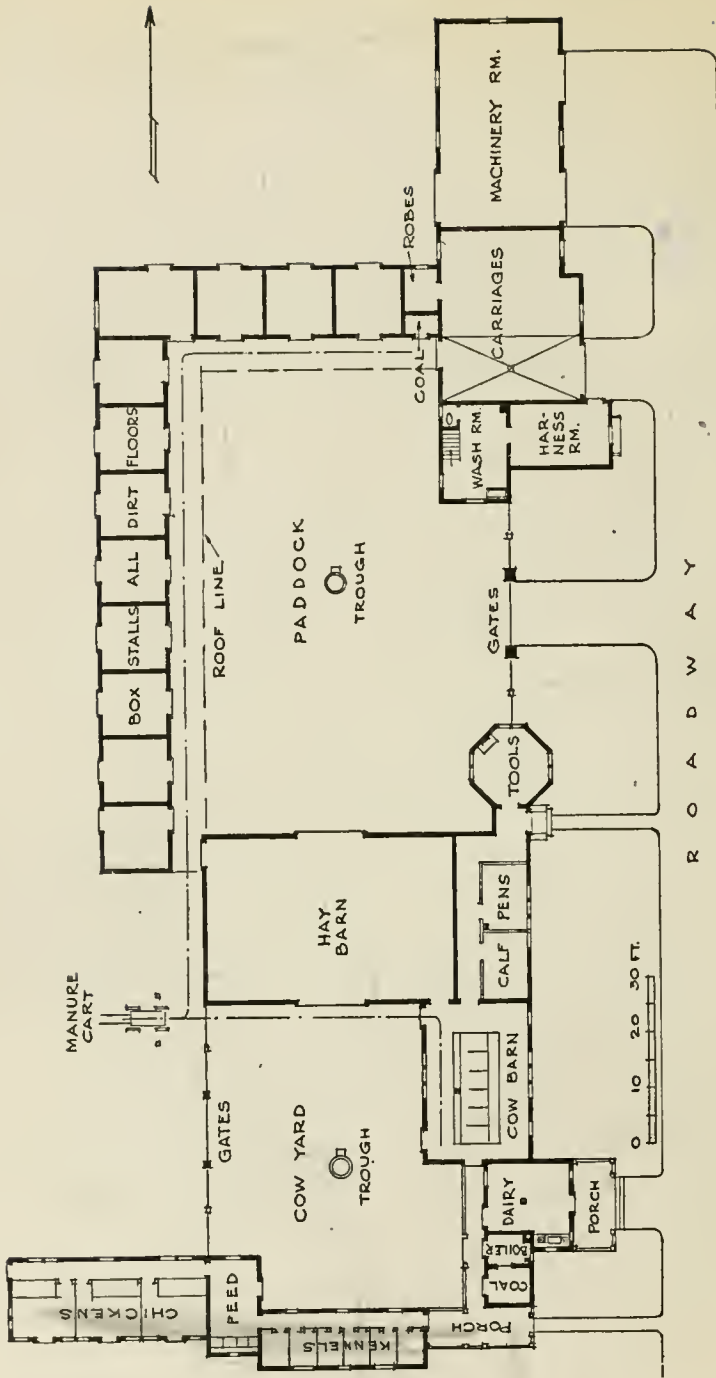

Alfred Hopkins, Architect

FIG. 45—PLAN OF FARM BUILDINGS AT BROOKVILLE, L. I., FOR J. E. DAVIS, ESQ.

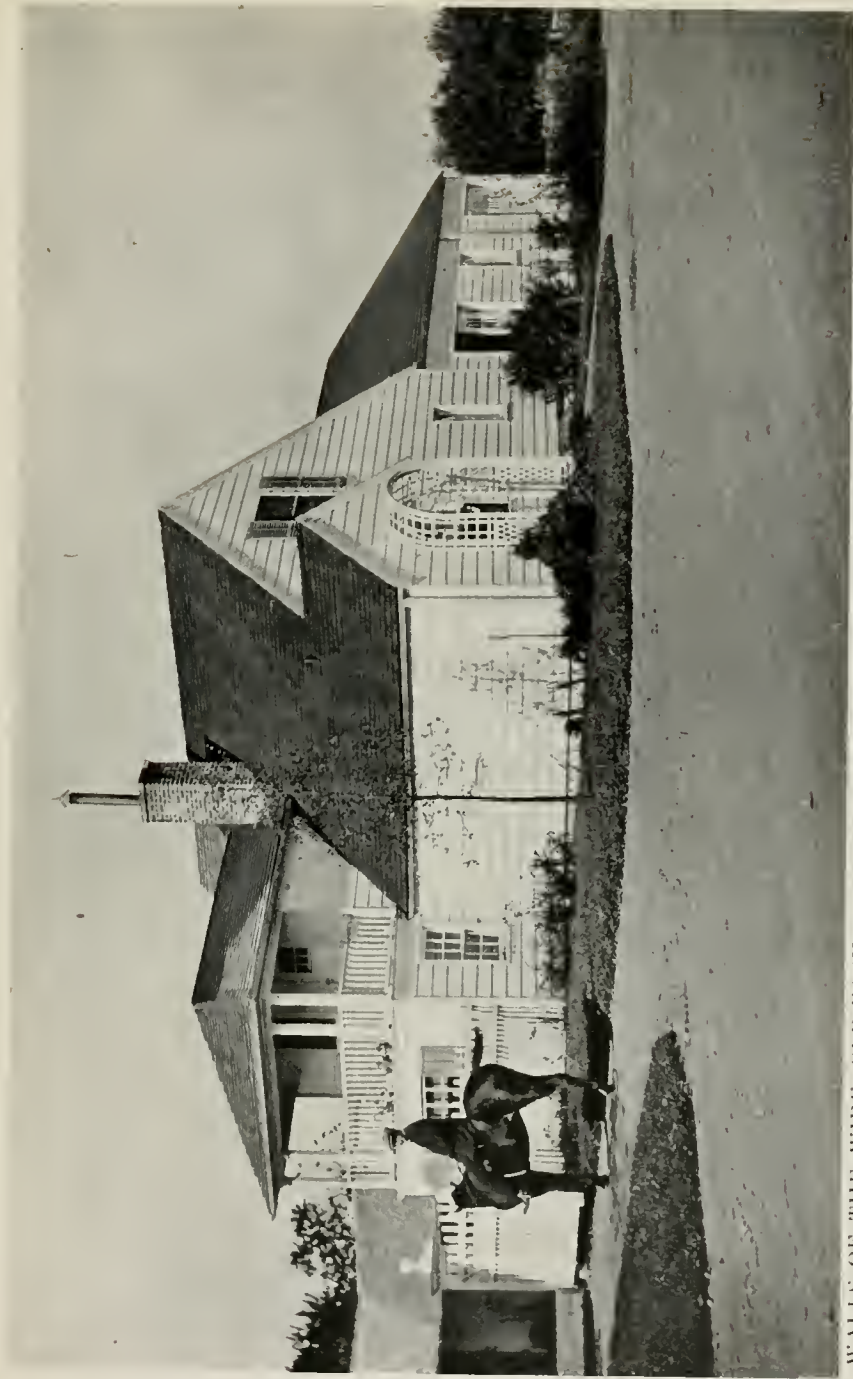

WALLS OF THE WIDE, OLD-FASHIONED CLAPBOARDS; ROOFS PAINTED A LIGHT GREEN. FARM BUILDINGS FOR J. E. DAVIS, ESQ., BROOKVILLE, I. I.

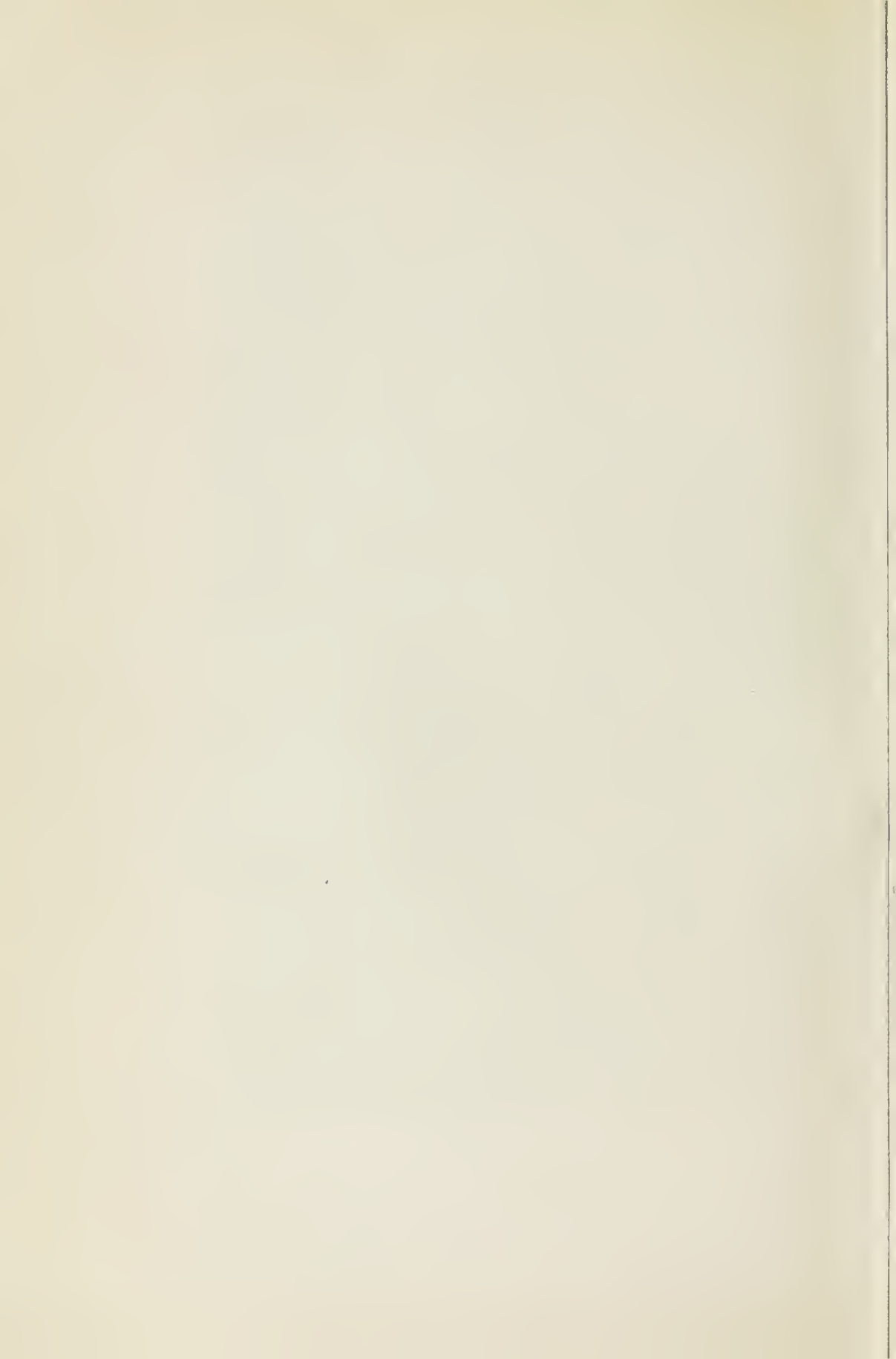

be contaminated by noise, but to the individual who walks through these kennels it would seem as if such a thing were not unlikely. This scheme is not to be recommended on general principles, but in this instance it seemed to be the right thing. Both the dog kennels and the chicken houses have been run east and west, so as to have the advantage of a southerly exposure for the runs. These low buildings come across the south of the cow yard and form an enclosure without too much obstruction. The horses are quartered in twelve box stalls, with Dutch doors on each side; the long overhang of the roof provides a convenient place for the manure trolley, which is tracked to the manure shelter to the west of the hay barn. The men's quarters are located over the carriage and harness room, with a second-story porch, and a machinery room is added at the end of the building. The tools are stored at the bottom of the tower, while the top is devoted to a flock of pigeons—always a picturesque adornment. The buildings have been carried out in the simplest possible manner, with wide clapboards and shingle roofs and in the hope that their general type is such as will not look out of place on an old farm some way back from the pleasant shores of Long Island.

FARM BUILDINGS AT OYSTER BAY, L. I.—Fig. 46

The plan of the buildings here shown calls for an average problem, so far as actual requirements go. The original building, consisting of the hay barn, horse barn, cow barn and dairy, was built some five years ago. The owner subsequently became interested in thoroughbred cattle and wanted to enlarge his farm buildings—a not infrequent occurrence. For this reason, in choosing the site for the farm barn, the architect

should see to it that there is sufficient space around his original group to allow for possible extension in the future. In two instances that have come within the author's experience, the farm has been put to real inconvenience because the build-

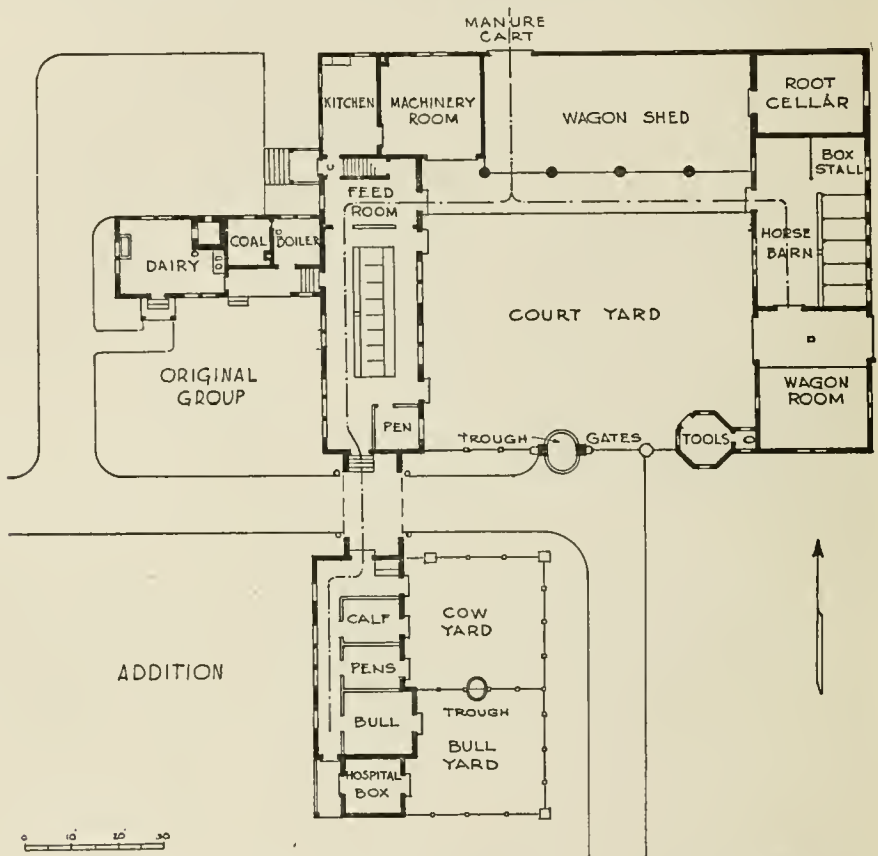

Alfred Hopkins, Architect

FIG. 46—PLAN OF FARM BUILDINGS AT OYSTER BAY, L. I., FOR MORTIMER L. SCHIFF, ESQ.

ings were originally located in a place so cramped that it was impossible ever to add to them.

Not so long ago, the problem came up of adding, to the above plan, space for young stock and dry stock, and it was



VIEWS BOTH WAYS THROUGH THE ARCHWAY CONNECTING THE NEW
YOUNG STOCK FARM TO THE MAIN GROUP

FARM BUILDINGS FOR MORTIMER L. SCHIFF, ESQ., OYSTER BAY, L. I.

decided to put a new building to the south of the present cow-barn and let the existing road come between. Connection was made by an arch over the road, and two fine cedar trees which had grown to mature years at the edge of the pasture were brought very happily into the scheme by extending the road beneath the archway so as to pass between them. The manure trolley, obliged to run across the roadway, was arranged to lift at that point.

The addition of the young stock wing brought the yard for the young stock directly on the main road to the farm building, and as the ground sloped there to the south, the yards had to be raised. This made dry yards and brought into prominence the young thoroughbreds within by placing them at the very edge of the main thoroughfare to the farm. The other features are the usual ones, but the author would like to dwell a little on the thought and care given to the addition to the original buildings, which became on that account a distinct improvement to them. It frequently happens that additions to the farm buildings do not achieve this end, such further building being frequently left to inexperienced hands. The tower shown in the background was erected to conceal an ugly iron water tank, and also to provide a viewpoint which should command the surrounding country.

FARM BARN S AT NORTH EASTON, MASS.—Fig. 47

This plan shows a new feature, in the way in which the two wings come to a common feed room. The advantage of this arrangement is seen in the ease with which the cattle are fed. This farm group is designed for the owner of probably the finest herd of Guernseys in this country, one who would listen to no reasons for sanitary milk, saying that his milk was dis-

tinctly a by-product and that his interests lay entirely in the breeding of his cattle. For this reason calf pens were put

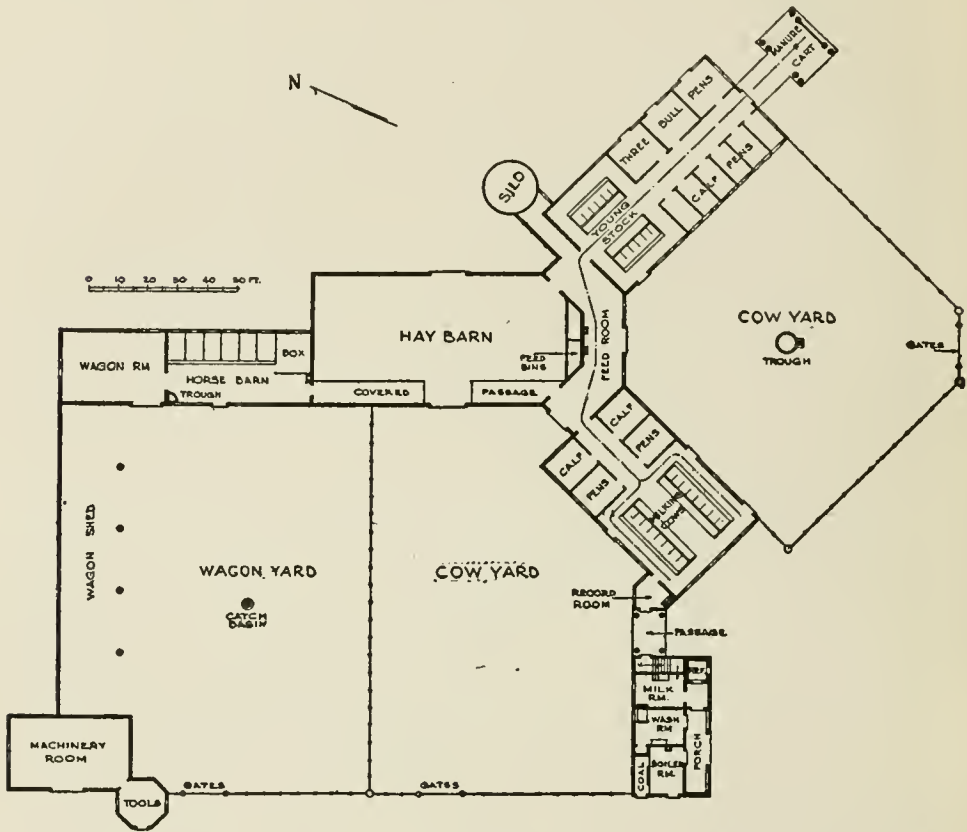

Alfred Hopkins, Architect

FIG. 47—PLAN OF FARM BUILDINGS AT NORTH EASTON, MASS., FOR F. LOTHROP AMES, ESQ.

in the milking cow barn, so that the calves could have the benefit of the warmth from the mature animals, a custom which prevailed generally some eight or ten years ago. The location of the feed room was original and distinctly successful, but apart from this the plan follows out the usual arrangement.



SHINGLE ROOFS; CLAPBOARDED WALLS, PAINTED RED WITH WHITE TRIMMINGS



FARM BUILDINGS FOR F. L. AMES, ESQ., NORTH EASTON, MASS.

FARM BARN S AT NEW BOSTON, N. H.—Fig. 48.

This plan shows a distinctly commercial barn, devised with no idea of architectural embellishment. The thing considered above all was the cow barn, which, while it follows out the usual practice, was made as low as possible with a flat, fireproof roof, so that the ventilating shafts at the side of the building could be run well above the roof, and be as efficient as it is possible to have ventilation when acquired from natural sources. In the paragraph on ventilation it has already been stated that vertical ducts of this description, if run well above a flat roof, are perhaps the most efficient, and this assertion seems to have been borne out in the ventilation of this building. Where the cows are bedded with the shavings generally used in large plants of this character, a special bedding bin is desirable, and was here constructed so as to be filled from the outside; the corner being cut off so that the horses could proceed around through the hay barn without backing out. The silos are located in the usual manner, opening into the feed room and, in the corner of the hay barn on a lower level, is a room for the steam roller, utilized as the motive power for the ensilage cutter and blower. As there was already a large dairy on the farm, all that was wanted in connection with the new cow barn was a can room where the cans could be washed and kept for milking and for delivery. A wash room for the men was provided in a small building adjoining the cow barn. The manure was disposed of in the simplest possible way, by tracking it through the side of the building, where it is emptied into manure spreaders and carted away daily.

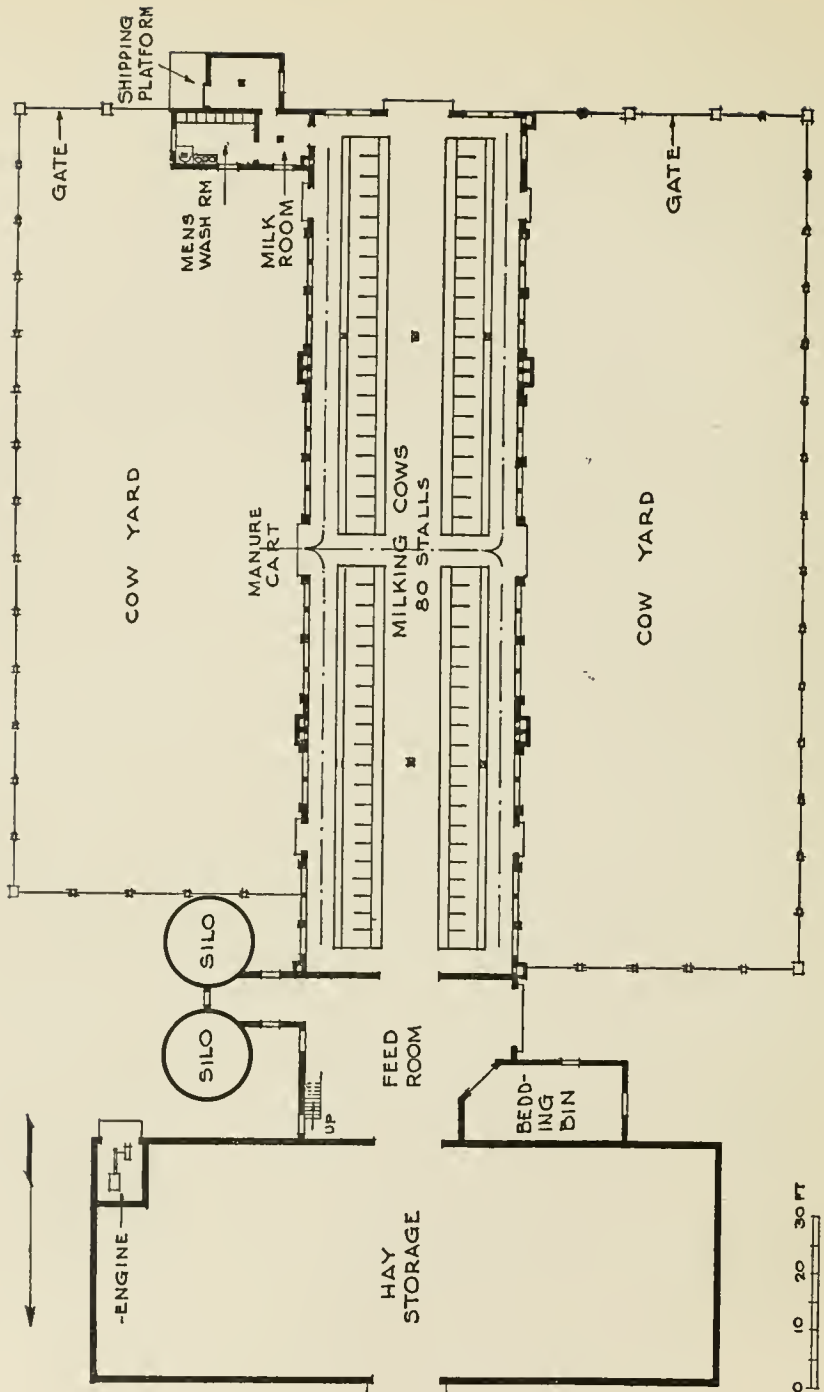

FIG. 48—PLAN OF FARM BUILDINGS AT NEW BOSTON, N. H., FOR J. REED WHIPPLE, ESQ. Stanley Cunningham, Jr., Architect



FARM BARNS AT NEW BOSTON, N. H., FOR THE J. REED WHITTLE CO.

THE BRIARCLIFF FARM, WHITE PLAINS, N. Y.—Fig. 49

This shows an extended barn containing stalls for two hundred cattle, the plans of which were drawn by Mr. Robert W. Gardner, New York City. This is strictly a commercial plant, but worked out carefully with a view of fulfilling the most exact sanitary conditions. This barn was a unit of a group

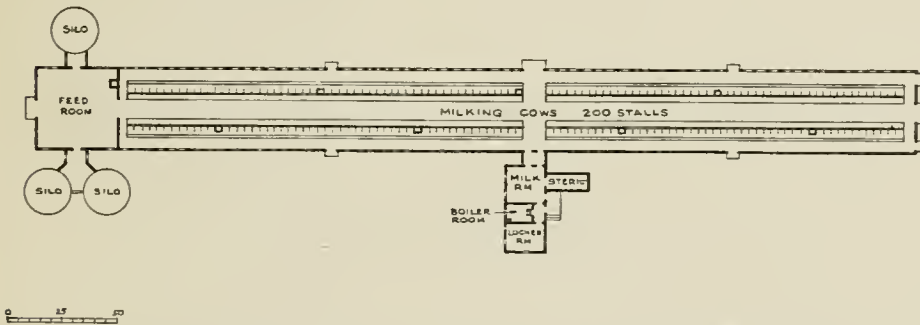

Robert W. Gardner, Architect

FIG. 49—PLAN OF THE BRIARCLIFF COW BARN, PINE PLAINS, DUCHESS CO., N. Y.

of some three structures of similar design which were located at various places on the farm. To this barn has been added a milk cooling room, locker and wash room, sterilizer and boiler. Although there is elsewhere a central bottling room where all milk is bottled, the milk is cooled, the cans washed and sterilized at the farm barn itself. Each barn has therefore its own dairy, equipped with every modern appliance for the care of milk except the bottling table.

The ventilation is entirely satisfactory, the outlet ducts being the size of one stall and running from the floor of the building up through the roof to a height of 40 ft. While these vents are unsightly, yet in a building of this character the practical thing must prevail, and nothing more practical than this arrangement for the outlet duct could be devised. The

inlet duct, instead of being placed in the wall where it would have been cramped in size, is put directly on the outside of the building.

The stall gutters have been put in level, and after being cleaned out are hosed down and broomed out. The concrete

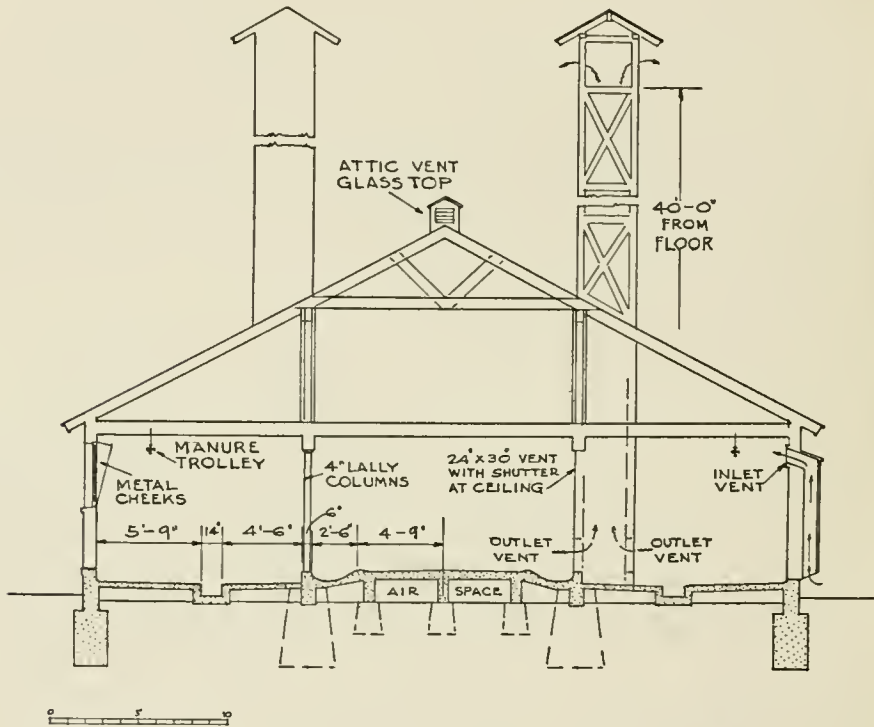

Robert W. Gardner, Architect
 FIG. 50—SECTION THROUGH THE BRIARCLIFF BARN

floors were all kept above the ground, as shown in Fig. 50. This has proved to be very satisfactory and it is found that the floors keep much drier and warmer when they are raised above the earth in this manner. The feed is kept in the second story, over the feed room, although this second story space encroaches some 52 ft. over the end of the cow barn.



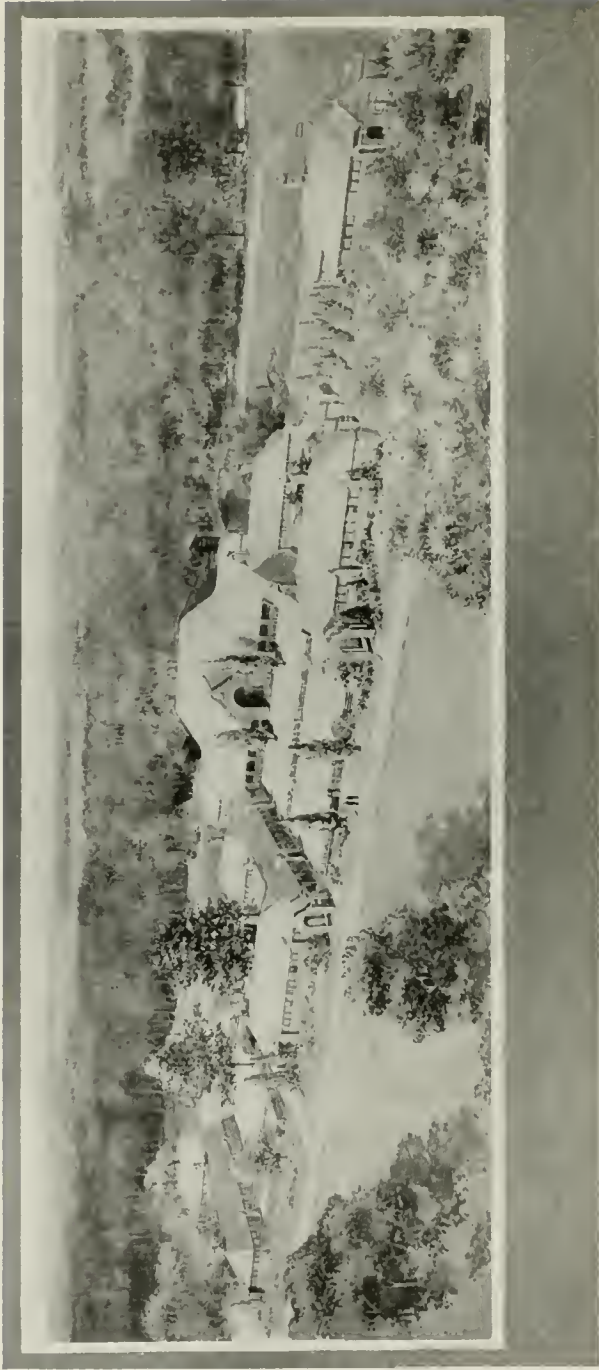

PROPOSED FARM BUILDINGS FOR THE LATE HUGH J. CHISOLM, ESQ., PORTCHESTER, N. Y.

PROPOSED FARM BUILDINGS AT PORTCHESTER, N. Y.—Fig. 51

While the author was engaged in preparing the foregoing pages for the press, he was also hard at work upon the scheme he here presents, and which is the result of much thought and careful consideration and investigation.

The problem was this: a gentleman having purchased a country estate, already of considerable architectural interest, had become fascinated with the idea of having and developing the finest herd of Ayrshire cattle in America, and he wanted to house this herd in buildings which should be creditable in appearance and as perfect in every detail of comfort and healthfulness as human thought and ingenuity could make them. The owner had given much of his own time to the problem and developed some very practical ideas in methods of administration, which will be referred to in the discussion of the plan. A beautiful site was available (though not until additional land was purchased), which was protected on the north by a dense woods and open to the south, the east and the west to an exceptional degree.

It was decided to keep eighty milking cows, and these are housed in two barns, the milk room—from which the milk is sent by trolley to the dairy—being placed between them. This milk room is arranged so that the records of the two milking barns are kept on opposite sides of the room, as are also the wash-basins for the men. Though the one milk room answers for both barns, yet the milkers and the records of each barn are kept distinct and separate. The milk room is reached through passageways leading from the east ends of the cow barns. Connecting the west ends of the cow barns is a long room in which it is intended to wash and clean the cattle pre-

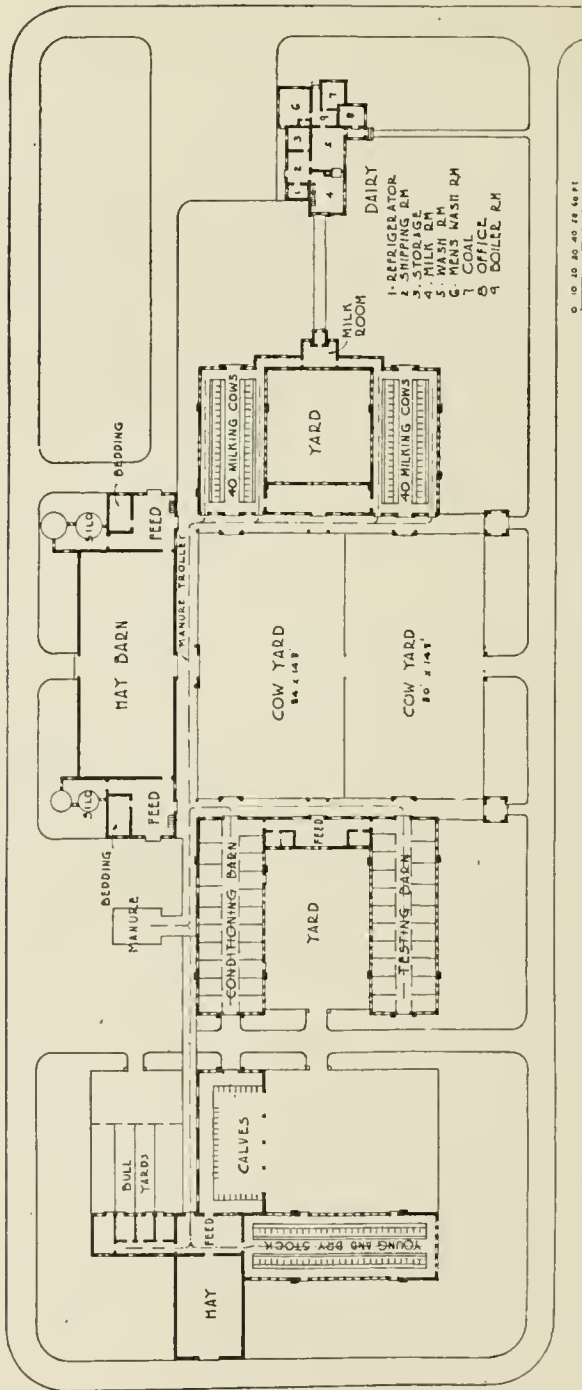

Alfred Hopkins, Architect

FIG. 51.—PLAN OF PROPOSED FARM BUILDINGS AT GREENWICH, CONN., FOR THE LATE IUGH J. CHISOLM, ESQ.

paratory to milking, although it is not improbable that this room, in time, may be given up and the space used for additional milking cows, as the herd increases in size and importance.

Opposite the milking barns are two barns, which have been called the "Conditioning Barn" and the "Testing Barn." The Conditioning Barn will be under the direction of one man whose duty it will be to put the cow in the best possible physical condition preparatory to having her calf. This is the owner's contribution to the plan, and a very excellent one it is. This barn is equipped with twenty box stalls and with a separate feed room for special feeds. There is also a room which will contain a hot-water heating system, for both the Conditioning and Testing Barns. In the Conditioning Barn the cow will have her calf, and, after the proper interval, if it is decided that she is to try for the advanced registry, she will be taken into the Testing Barn for that test. This barn, like the Conditioning Barn, has twenty box stalls, and has, perhaps, a slight advantage over that barn in location. The box stalls here have Dutch doors, and in both structures the stall partitions have been made only 3 ft. high, though above this is a 2-in. galvanized iron pipe rail at a height of 4 ft. above the floor. This partition, shown in Fig. 9, will obscure the animal less and will afford better ventilation than any other yet suggested.

Perhaps the most interesting feature of the plan is the way the four cow barns are placed, forming a great court, with the hay barn at the northwest. The hay barn and the four cow barns are all connected by a continuous covered passageway, through which the feed is distributed and the manure is trolleyed to the manure carts. This covered passageway

will be utilized as a shelter for the cattle in the winter, when they will be turned out every day for an airing. One of the best ways to keep cattle moving and exercising in cold weather is to feed them in the yard, and the plan adapts itself most readily to an easy carrying out of this idea. The great court is divided in the center, so that the cattle from each of the milking cow barns may have a separate yard of their own. The disposition of the feed rooms and the construction of the hay barn are all along the lines which have previously been advocated and illustrated, but the arrangement of the cow barns is quite a new feature and one that seems certain to work out well both practically and architecturally.

The dairy is designed along familiar lines, the only variation being that all the service—the shipping of the milk and the return of the cans—is maintained at the rear of the building, which keeps the front entirely free from the traffic of the milk wagons. Additional space—and space that is conveniently located to the wash room and refrigerator—has been left for the incoming and outgoing cases. To meet the regulations of the Board of Health, a lavatory has been omitted from the dairy building, though the author believes that such a regulation is entirely unnecessary in a building of this character, where every sanitary detail will be looked after and provided for in the most careful manner.

The young stock buildings have been incorporated in the main group so as to be readily accessible to the feed and manure trolley systems. The barn for calves is open to the south, and is nothing more than a shed in which at all seasons of the year the calf romps in and out at pleasure. This method of rearing the young animal has been accompanied by the most

satisfactory results, and is infinitely better than keeping them in an enclosed barn.

As the calf matures and grows larger, it is quartered in the young stock barn and here fed in the stanchion. A small hay barn for the storage of the hay and straw for the calves has been included in the young stock group, though the grain and ensilage is conveniently brought from the main storage. The young stock quarters are connected by a covered passageway, so that the entire group may be inspected under cover. Connected to this passageway are the bull pens and their yards. All the manure is conveniently trolleyed to the one manure shelter, large enough to accommodate three carts.

The buildings are to be carried out in yellow brick, with shingle roofs, and the woodwork, which is left rough from the adze, will be stained a soft brown. The two fine trees between the young stock and the main group—one a maple, the other a sycamore—nature has developed into splendid specimens, and at the rear end of the broad roadway in front of the buildings, an old apple orchard will give up one of its rows of trees so that a straight and uninterrupted avenue may be continued in front of the new farm buildings.

The plans and photographs herein set forth show only a few of the many varieties of expression which may be given to the farm barn. It is earnestly hoped these have demonstrated that such buildings can be made not only practical, but may have an architectural character entirely their own. In our present methods of haste, especially with regard to things artistic, the esthetic value of the farm barn has been entirely overlooked. Men have lavished vast sums in the building of the house and in the adornment of the coach stable, in great

gardens and woods and bridges, but the home of the farm animal has received but little attention from those who would make it sightly as well as sanitary.

The far greater part of this book has of necessity been devoted to the practical things, for the architect of our times must build usefully as well as artistically, but the author would feel that his work had been in vain if he has not shown that the farm buildings may be made an attractive addition to any estate, as well as a more comfortable and healthful place for the patient creatures who dwell within them.

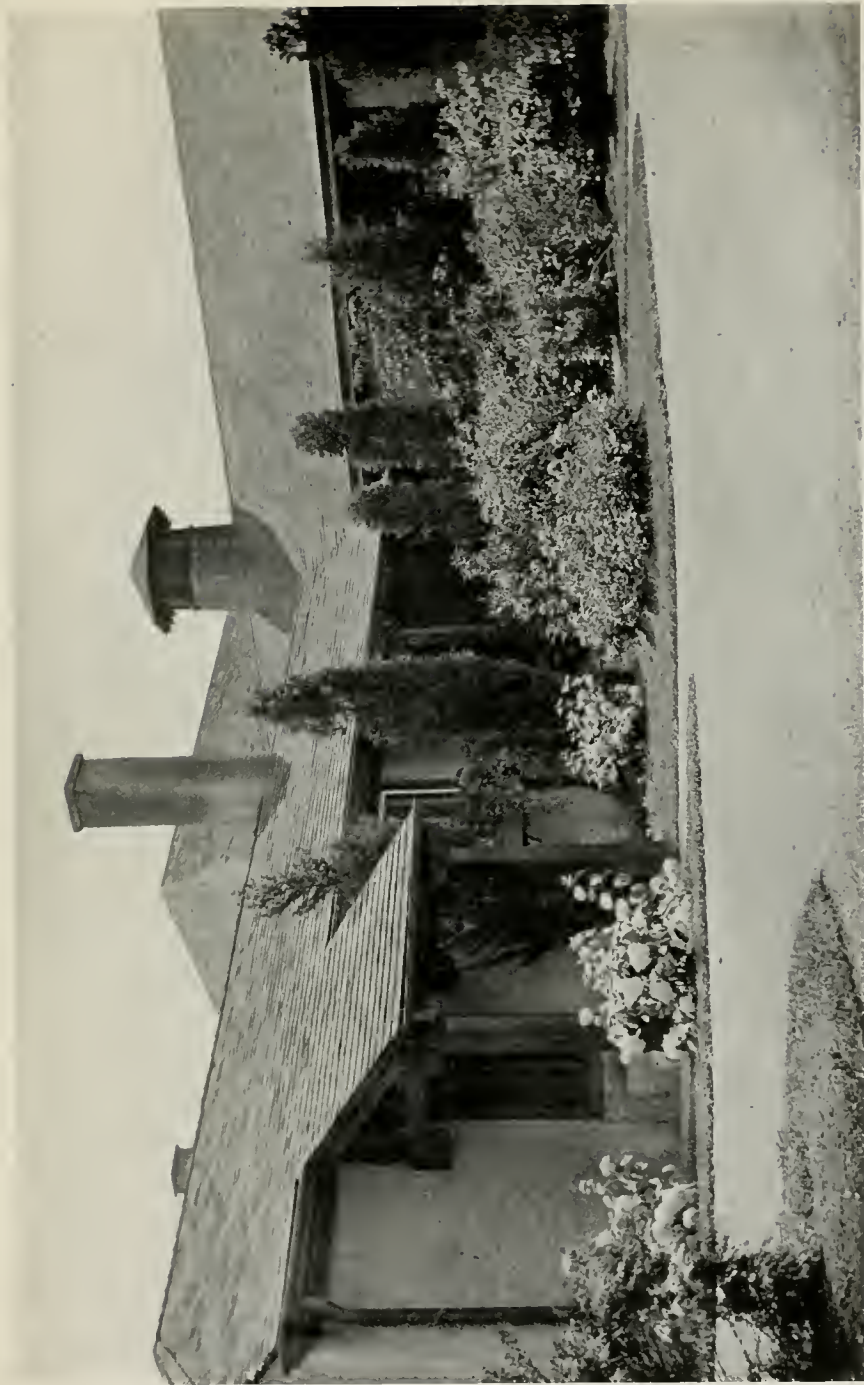

SOME OF THE PLANTING AT THE DAIRY. FARM BUILDINGS FOR MORTIMER L. SCHIFF, ESQ.,
OYSTER BAY, L. I.

CHAPTER VII

THE SMALLER PROBLEM

IT occasionally happens that the architect is called upon to design a building for a horse and a cow, or latterly an automobile and a cow, the owner wishing to provide against the possibilities of impure milk by securing it fresh from his own animal. Generally, the cheapest and best method for such a farmer to pursue in his quest for clean milk is to buy

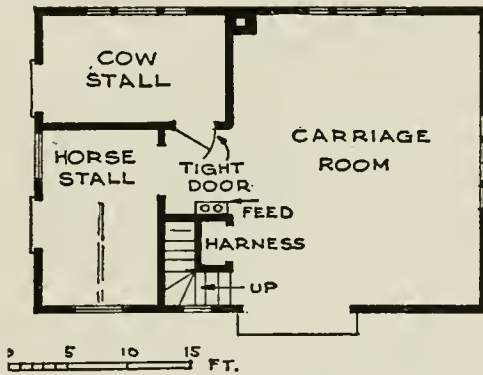

O. S. Keefe, Architect
FIG. 52—PLAN OF SMALL STABLE FOR
HORSE AND COW

it. If he can purchase milk which has been certified, it will be cleaner and better than any he will be likely to produce for himself. If he lives where such milk is not obtainable or wants the fun of creating his own milk supply, that is another matter, and one which we will now take up briefly.

The disadvantage of keeping the single cow has not to do

with that patient animal itself, but with the care which it is necessary to take in keeping her clean and in milking her properly in sanitary surroundings. Such an establishment is usually taken care of by "the man," who works in the garden, tends the horse, and is as likely as not to clean out the horse stable just before he seats himself to milk. To teach such an individual and to hope that he will retain the most rudimentary knowledge of what is necessary for clean milk, seems too much to expect. A good housekeeper would hardly call upon the stableman to come directly from his work and help the cook prepare the dinner, and yet it is quite usual to have him proceed under those conditions to prepare the milk, which is eaten raw, and is a much more delicate substance and more liable to infection than any cooked food prepared in the home. Consequently, the substitution of a dairy maid for the milking at least is greatly to be desired. If this is an impractical suggestion, and perhaps the carrying out of it might cause a revolution in some households, then the only thing is to urge "the man" to be as clean as possible and try and remember to wash his hands before he milks, and to give up the habit of chewing tobacco during the operation. The cow's hair on her flanks and udder should be clipped and not allowed to grow long. This is important. If the cook finds cow's hair and dandruff on the foam in the milk, then "James" should be spoken to about it. All the milk things should be boiled every day, and the milk, as soon as milked, should be put in bottles and kept in the refrigerator. A cooler is quite unnecessary for the one-cow problem. A clean apron, fresh at least twice a week, should be used at milking, and it must not be kept in the stable. It is probably better to milk the cow at her tether than in the average stable, though this is bad practice for the

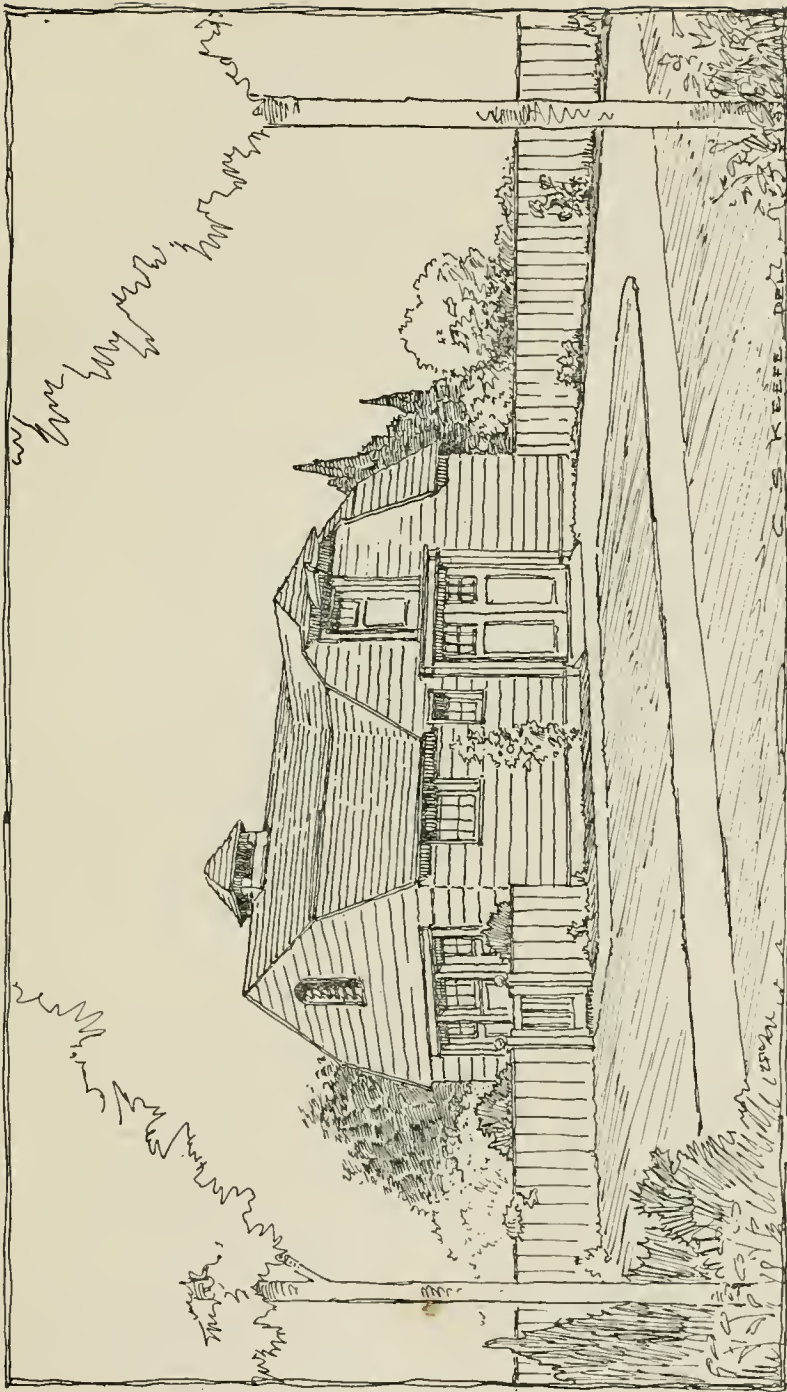

C. S. Keefe, Architect

FIG. 53—SKETCH OF SMALL STABLE FOR HORSE AND COW

serious problem; milk drawn in the field always shows, on analysis, the presence of bacteria.

A separate milking shed with concrete floor would not be expensive and would be an excellent idea. Here a wash-basin could be provided and a place prepared for the storage of milk utensils; in fact, a combination milking barn and dairy. Real cleanliness is the thing required, but seems never to have been thought necessary for the care of milk. The proprietor of the

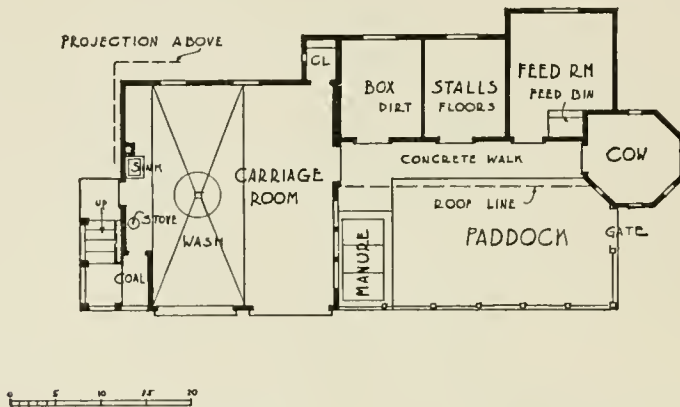

Alfred Hopkins, Architect

FIG. 54—PROPOSED SMALL STABLE AT HEWLET, L. I., FOR H. T. S. GREEN, ESQ.

farm we are discussing should have his wife read carefully the preceding notes on "Administration" and carry them out as far as possible. A housekeeper's common sense directed toward such a milk supply will be all that is necessary, and if she will but keep her cow and stable as clean as she does her kitchen where other food is prepared, she will not need the advice of specialists on milk production.

With regard to the plan of the building, there are few things of importance after having entirely separated the cow from the horse and arranged proper ventilation for both their com-

partments. The cow stall should be reached through outside air only and should never be directly connected with the horse stable. The manure pit is best eliminated and the manure put into covered galvanized iron cans. These cans can be emptied on a compost heap in the garden, and must at all times be kept clean.

The storage of feed is usually had above the stable, but it adds to the appearance as well as the convenience of the building to arrange a small feed room on the first floor, between the cow and the horse.

Each animal is best kept in a box stall, which—for the horse—may be divided temporarily for two animals by a movable partition already referred to.

The interior of the stable is best carried out in plaster in preference to wood, and the entire structure should follow the lines already suggested for the modern farm buildings. Figs. 52, 53 and 54 show simple solutions of the smaller problem.

CHAPTER VIII

THE GARAGE

THAT the automobile is quite as important on the modern farm as the other equipment, goes without saying, and there is no reason why a space for the automobile should not be arranged in the farm group, provided this is done in such a manner that the garage will have its separate entrance. This of course should be as far away from the cow barn and horse barn as possible. The automobile should never be allowed to come into the general courtyard. Farm horses are, perhaps, more disturbed by it than any others, and in the small problem, where the horses and cows are necessarily near together, it is much better to eliminate the automobile from the group and put up a separate garage at a distance. The garage is better combined with the coach stable or the farm stable. Fig. 55 shows a plan for a large farm stable where the garage has not only its separate entrance to the building but its separate roadway from the main thoroughfare through the estate. Consequently there is no reason for the chauffeur to bring his machine even on the road which leads to the entrance of the stable. Fig. 56 shows the garage combined with a stable which was built in such a confined situation that it was impossible to separate as much as is desirable the entrance to the garage from the entrance to the stable. The plan, however, has some interesting features—notably the outdoor wash between the garage and the stable for the use of both, which



GARAGE DOORS OPENING OUT. TEMPORARY GARAGE FOR CLIFFORD V. BROKAW, ESQ., GLEN COVE, L. I.

has been utilized to separate the garage and stable, and yet combine them in one building. The garage has space for three cars. The projecting bay in front makes the building more at-

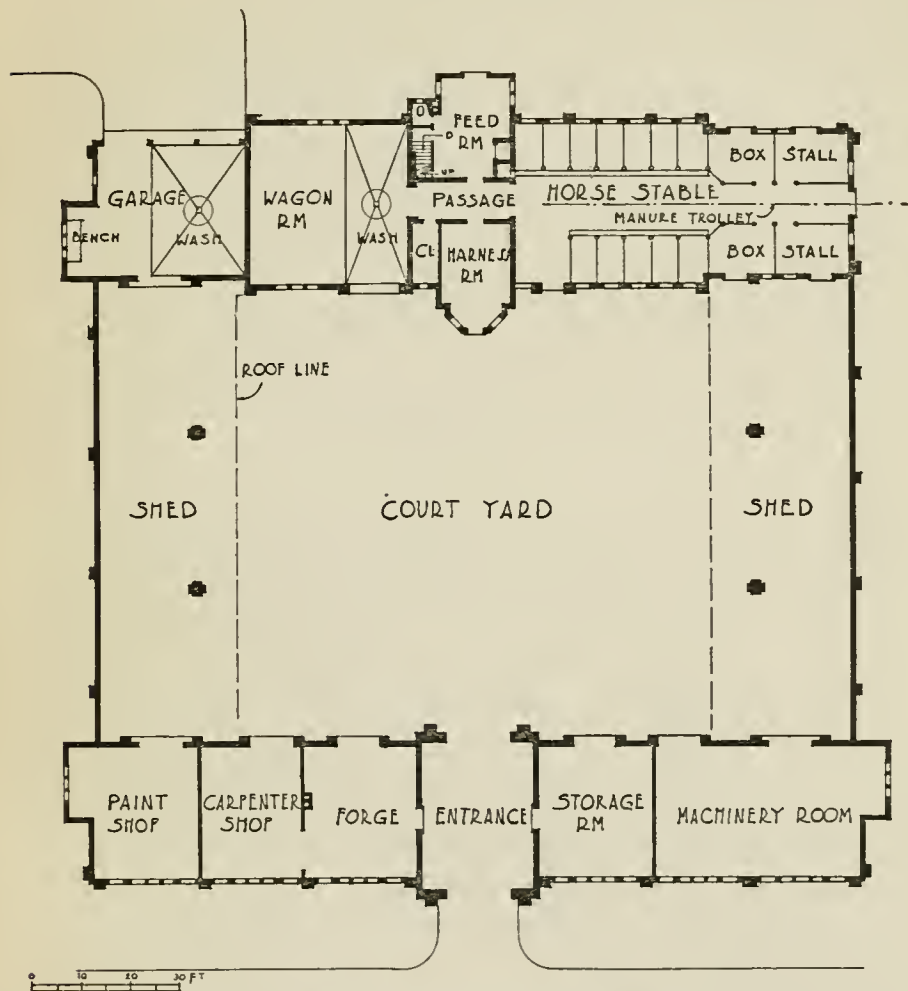

Alfred Hopkins, Architect

FIG. 55—PROPOSED FARM STABLE AT GREENWICH, CONN., FOR THE LATE HUGH J. CHISOLM, ESQ.

tractive at that end, the point of approach, and affords space besides for a work-bench and a closet for tools. In the second

story of the stable an apartment—and one with a very attractive exposure—has been arranged for the coachman; his entrance being from the porch on the corner and always through the outside air, thereby avoiding any possibility of the odors from the stable reaching the living quarters. From the kitchen projects a second-story porch, an addition to the

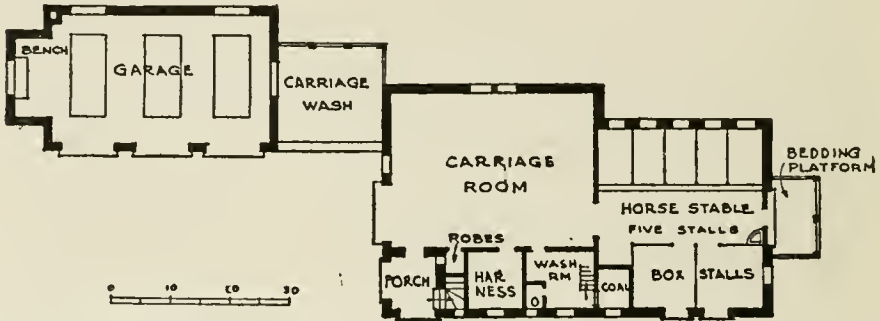

Alfred Hopkins, Architect

FIG. 56—PLAN OF GARAGE AND STABLE AT ARMONK, N. Y., FOR C. R. AGNEW, ESQ.

home which as yet is not generally appreciated. The building was constructed of rough field stone and the roofs of rived cypress shingles. The timber work of the porches and the overhangs of the roofs, of rough-hewn chestnut, are stained a soft dark brown which time is constantly increasing in depth of tone.

In Fig. 57 is seen a large plan with garage and stable combined in the one structure. Each has its separate wing and separate entrance. A most important feature of the architect's work upon the country estate is to combine his buildings—if not in one structure, at least in one group of structures—so that in the architectural composition all buildings will have a distinct relation one with the other. Nothing is more unsightly or shows less grasp of the architectural



ENTRANCE FRONT



THE BROKEN ROOF LINES AT THE BACK. STABLE AND GARAGE FOR
C. R. AGNEW, ESQ., ARMONK, N. Y.

phase of country work than to have various buildings of various sizes and various uses, erected of various designs and ma-

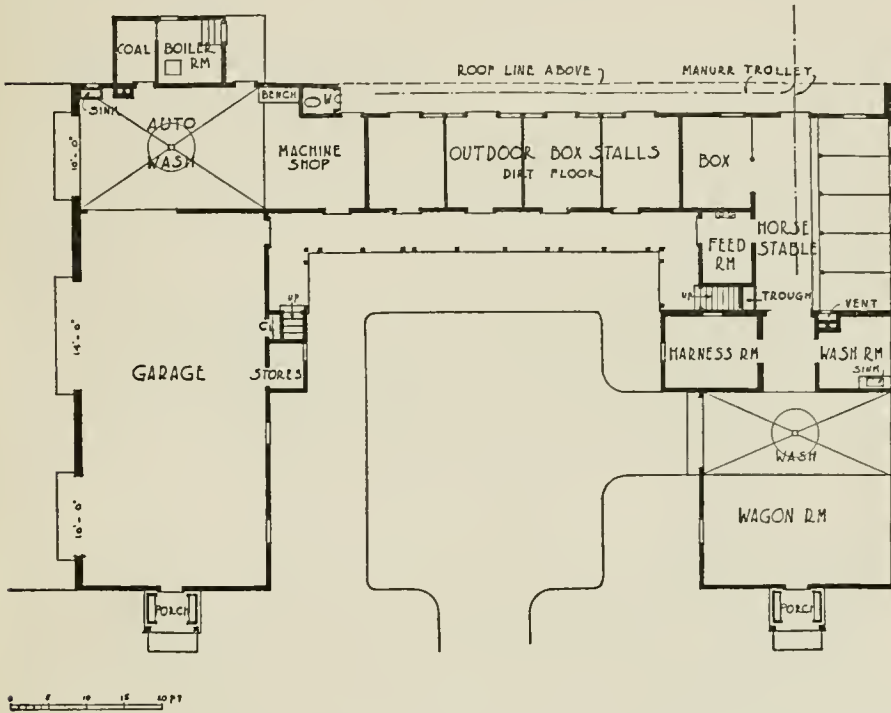

Alfred Hopkins, Architect

FIG. 57—PLAN OF STABLE AND GARAGE AT ISLIP, L. I., FOR J. HENRY DICK, ESQ.

terials in various places. To the discriminating eye, this is the very acme of all that is awful.

THE INDEPENDENT GARAGE

The equipment and arrangement of the garage itself is such a simple matter that it will be but briefly touched on here. The feature which is liable to put the designer in the greatest quandary is the doors. For a small establishment of, say, two or three cars, a door is certainly needed for each car space.

When it is possible, a single sliding door is the best. It is not always a disadvantage to have one door slide in front of another, as usually one large door in use at a time is sufficient. In Fig. 56, a garage with three doors, two of the doors were arranged to slide, and one—presumably the least used one—

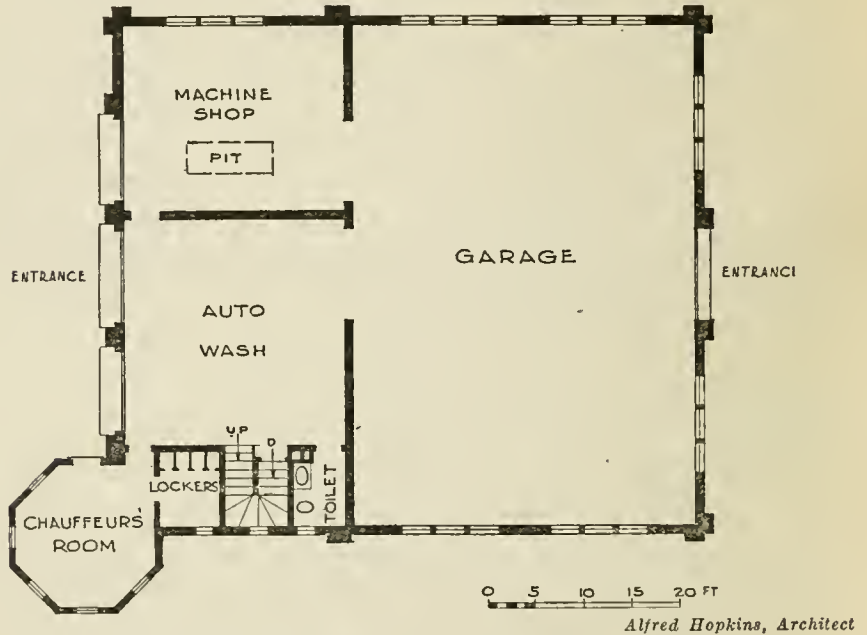

FIG. 58—PLAN OF GARAGE AT ISLIP, L. I., FOR S. T. PETERS, ESQ.

opposite the pit and repair bench, was hinged. This allows the two sliding doors to slide back of the hinged door so that two unobstructed openings are available at all times. In any group of three doors where one is swung out, it is always possible to arrange the other two to slide back of the swinging door. This swinging door is usually placed at the end but may be in the center just as well. For three doors this method of hanging them is probably the best arrangement.

Another type of door (see plate opposite) is frequently



PIGGERY OF S. T. PETERS, ESQ., ISLIP, L. I.



SHOWING ENTRANCE DOORS TO GARAGE FOR S. T. PETERS, ESQ.,
ISLIP, L. I.

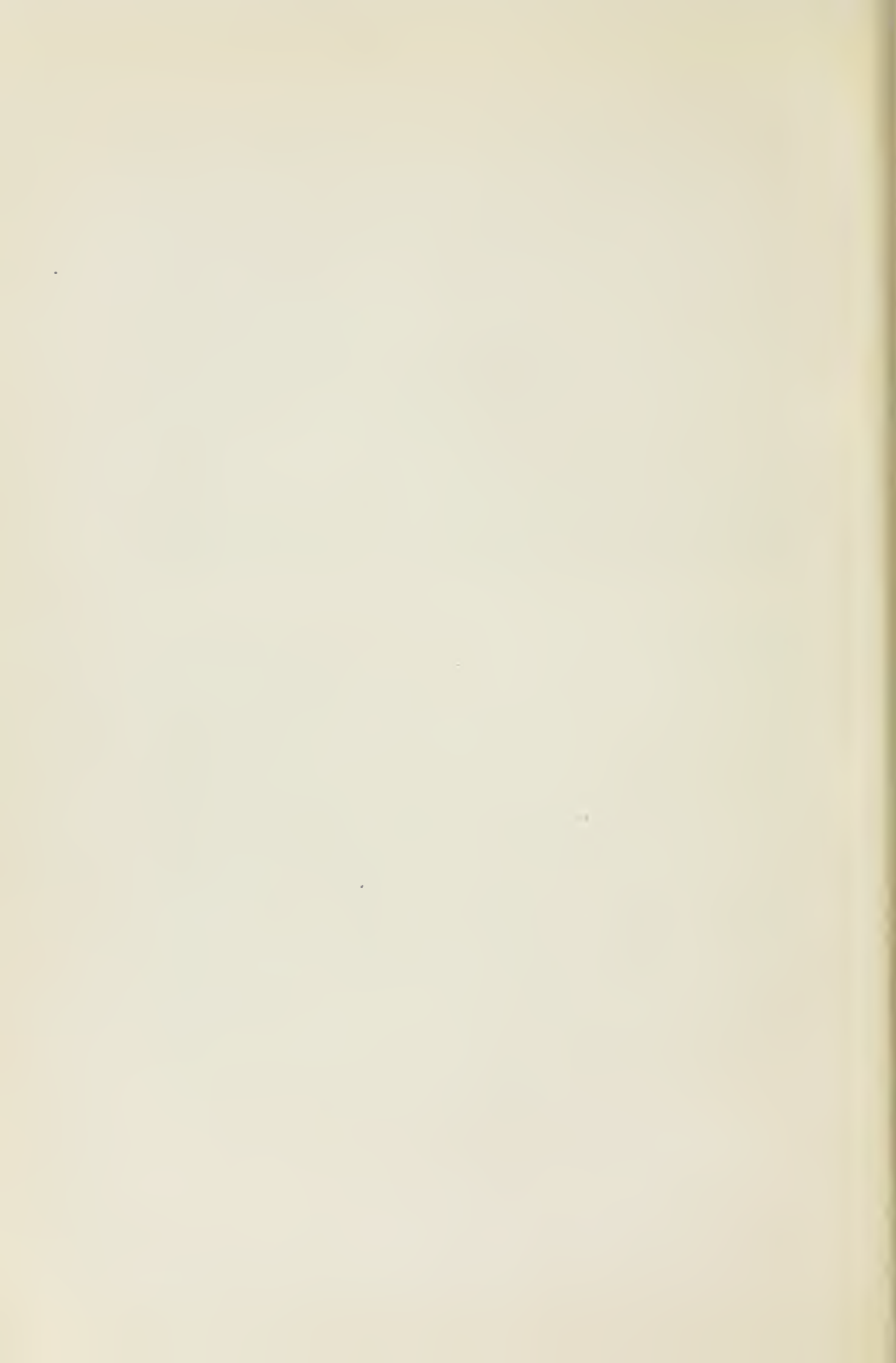

used. This folds in the center, horizontally, and by its mechanism is hoisted up and held at the very top of the opening. This allows any number of doors to be used at once, as each door is contained within its own opening, which has to be 10 ft. in height. This mechanism, while cumbersome, is not impracticable and is desirable under certain conditions. It was used for the garage at Islip, Fig. 58, where it was desirable on account of the number of machines in frequent use.

For a structure of a temporary nature the doors may be opened out (facing p. 170) and each door held open very readily by a stock hardware fixture, and one which seems to work well. For doors opening out this device is necessary, and doors hung in this manner are the least expensive in their installation. For important work the other two methods are the best, as doors swung out are unsightly and in the way.

Another method is to hang the door in four folds, that is, divide each half into two folds. This allows the doors to fold back into a 2-ft. jamb where they are well out of the way. The objection to this method is the number of bolts required to fasten each fold.

The foregoing suggestions with regard to doors are all made for the garage with entrance on one side only, and having a door for each automobile. As has been pointed out this plan frequently complicates the operation of the doors and in the plan shown in Fig. 57 the garage was designed with doors wide enough to allow storage space for two automobiles opposite the one door opening. This scheme was devised on the theory that one large single door, wide enough for two automobiles, is more easily handled than would be two smaller doors, especially where these are hinged in pairs, making four swing

doors for two openings. The two end doors in Fig. 57 slide in pockets, the center door sliding on the wall behind them; by this arrangement all doors may be used independently and all opened at once.

Apart from the doors the garage offers no difficulties, ex-

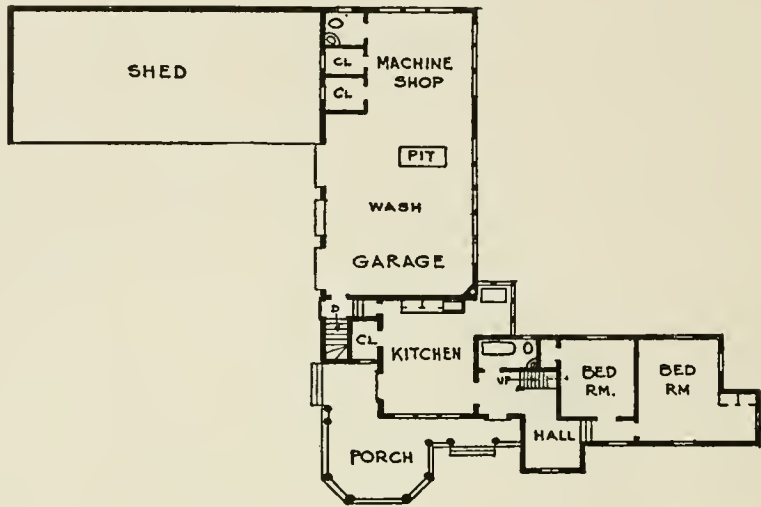

Alfred Hopkins, Architect

FIG. 59—PLAN OF A PROPOSED GARAGE AND CHAUFFEUR'S COTTAGE

cept to avoid the instinct which prompts most people to build too small. Ten feet should be allowed for the width of a car where each machine has its own door, and for the smaller machines the depth of the building should never be less than 20 ft. Where cars of 17 ft. in length are housed, a depth of 25 ft. is desirable. The doors should never be narrower than 8 ft. and 8 ft., 6 in. or 9 ft. seems of sufficient height.

In Fig. 58 is given the plan of a garage which has proved entirely satisfactory. The large room contains six cars, three on each side. The entrance is of sufficient width to allow one car to be washed and still leave a clear space for passage in

or out. The machine shop is to the left of the entrance and the chauffeur's room to the right. Over the front rooms are four sleeping-rooms with a living-porch on the second story, which caught the owner's fancy to such an extent that he had a similar structure added to his own home.

In Fig. 59 the plan is given of a garage and chauffeur's cot-

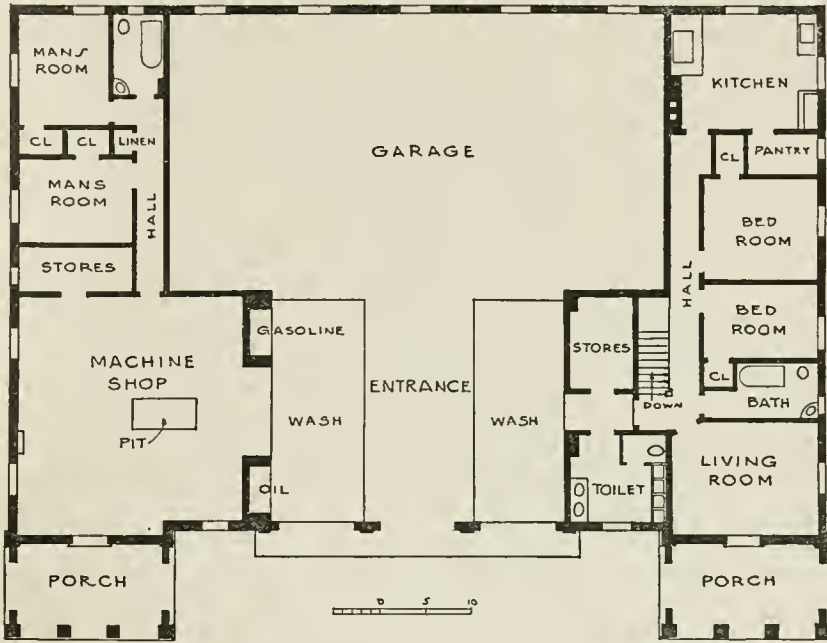

Alfred Hopkins, Architect

FIG. 60—PLAN OF GARAGE AT GLEN COVE, L. I., FOR CLIFFORD V. BROKAW, ESQ.

tage which has in addition a large shed for visiting machines—always a desirable and frequently a necessary feature in the private garage.

In Fig. 60 is shown a plan along similar lines to that in Fig. 57, except that the entrance is larger, accommodating two washes, one on each side of the entrance. In Fig. 57 the site

allowed entrance to the garage from the front and back, which simplified the problem greatly. In Fig. 60, entrance was to be had from the front only, which necessitated the widest possible opening from the wash to the automobile room. This does not separate the washing space quite as much as is desirable, for the wet and spatter of the hose is best kept entirely away from the clean cars. To partially overcome this

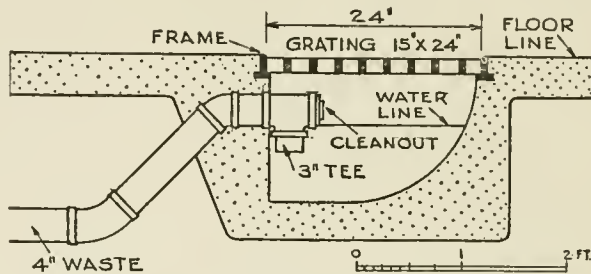

FIG. 61—DETAIL OF SAND TRAP FOR THE AUTOMOBILE WASH OR CARRIAGE WASH

objection in the plan (Fig. 60), an overhead washer was put in the machine shop, which will allow a third place where cars may be washed. Here the washing will be entirely out of the way—a disposition of the wash room which the chauffeur invariably prefers. Fig 61 gives the detail of a very good type of outlet for either the automobile wash or the carriage wash. This trap, called a “sand trap,” is formed entirely in the concrete floor. The sand from the washing will not stop up the soil line, but collects in the bottom of the trap, where it can easily be removed with a hoe. The grating and frame should be galvanized and the grating made easily removable.

In arranging for the chauffeur’s rooms the temptation is to put them on the second story on account of economy. This is a delusion. It is not an economy, and much more artistic

results are obtained by keeping them on the first story. By so doing, a more interesting mass of the building is possible, and more comfortable living-quarters are obtained.

The pump for gasoline is always desirable, and the tank must be 20 ft. away from the building and filled from the outside. The pipe should drain from the pump to the tank—never the reverse. In the plan shown in Fig. 60, two deep alcoves on either side of the door to the machine shop have been arranged: one to receive the gasoline pump and hose, the other the enameled iron cabinet for the lubricating oils.

CHAPTER IX
OTHER BUILDINGS OF THE FARM
CHICKEN HOUSES

THERE has been such a deal of controversy, at least in the author's practice, over the requirements of the chicken house, that he has felt an extended discussion of this building had better be left to those who are possessed with a knowledge of the subject, more satisfying to themselves. Every chicken man has decided notions of his own as to what is necessary for the successful chicken house, and no two men seem to agree as to what type of structure will best assist or persuade the hen to lay. A shortage of eggs has so frequently been assigned by the master of the hens to faults in the architect's plan that this architect at least has made up his mind—as has everyone else interested in chickens—that no one really knows anything about them but himself, and that a proper chicken house has never been built and never will be, until it can be carried out in its entirety by himself and himself alone.

What the hen needs more than anything else is fresh air, and to be assured of this it was thought that she needed almost unlimited range and plenty of room in her house. Crowding in the pen was the worst possible condition. A writer in *The Country Gentleman*, some years back, said that in the coop 10 sq. ft. of clear floor space per hen was desirable; this being exclusive of all passageways and floor space occupied by



EXTERIOR OF BROODER HOUSE



YARDS AND BROODER HOUSE; STORAGE SHED AT RIGHT. CHICKEN HOUSES FOR FRANCIS LYNDE STETSON, ESQ., STERLINGTON, N. Y.

nests, roosts, etc. A certain Mr. Philo, whose book¹ on this subject, though somewhat commercial, everyone interested in chickens ought to read, became enthusiastic over the idea of rearing chickens in the smallest possible space, and advertised that a successful egg farm could be established on a plot of ground 40 ft. square. We cite this as showing the very great differences of opinion that may be found with regard to the housing of the hen.

Undoubtedly, where space permits, the best method of arranging the chicken farm is to follow out the idea known as the Colony Plan. This is a separate and usually movable house large enough to contain a cockerel and from six to a dozen hens. On the Skylands Farm at Sterlington, N. Y., the two systems of the general chicken house and the colony house have been carefully compared and a decided preference has been given to the colony plan. The colony houses are usually movable and located at a distance from each other, although this is not necessary and the individual houses may be placed near together and permanently located as shown in plate facing p. 182, the fowls roaming over a dozen acres during the day return at evening each to its own home. This type of house should invariably be used for breeding purposes, as the birds, unconfined and left to roam about at will, are more hardy on that account. The records at Skylands show that they also lay better. Fig. 62 shows a drawing of the colony house used there.

This is a small building, 4x6 ft., which will house one cockerel and six hens. It is of two stories, the roosts and nests being above. The whole advantage of this type of structure lies in the ventilation. At the bottom of each long side there is an

¹ See list at end of this subdivision of the chapter.

opening 6x1 ft., 10 in, which can be partially or entirely closed, either with a solid wooden shutter or a sliding muslin screen. This opening regulates the admission of fresh air in a very

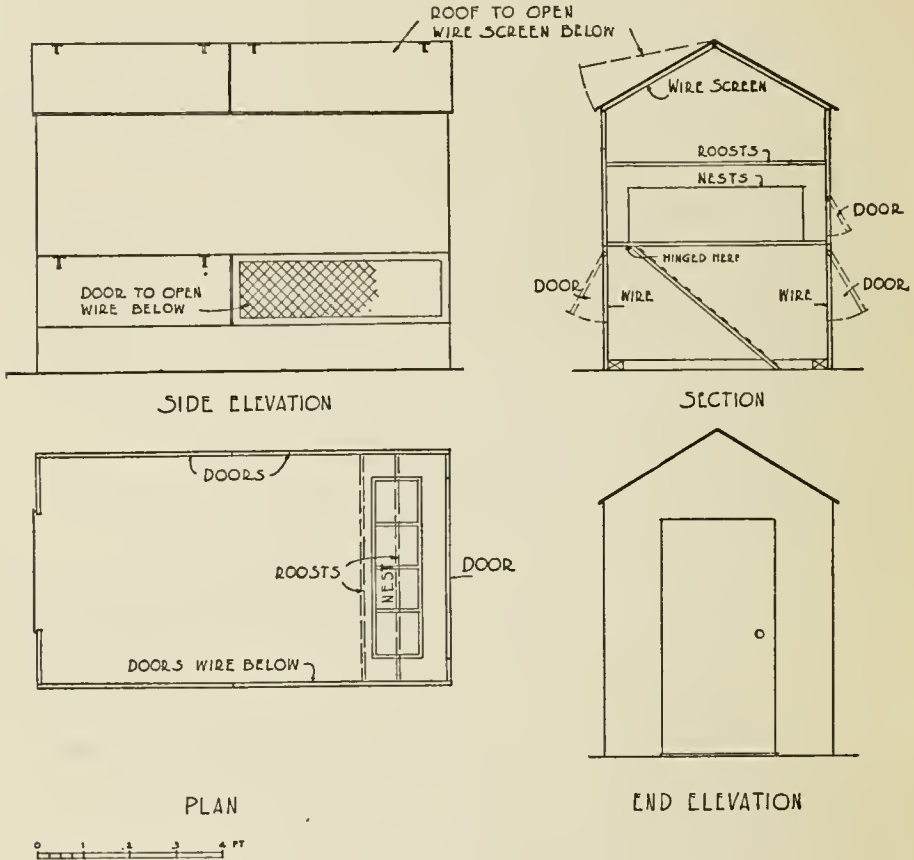

FIG. 62—PLAN OF COLONY HOUSE USED AT SKYLANDS FARM, STERLINGTON, N. Y.

flexible manner. One side of the roof is constructed to raise in two sections, and the opening so made is also arranged to be partially or entirely closed with a sliding muslin screen. Some care must be used in regulating the ventilation in winter, but this method of housing is admirable in providing the birds



COLONY HOUSES PERMANENTLY LOCATED



INTERIOR OF BROODER HOUSE—THE USUAL TYPE

with shelter without depriving them of fresh air. The chicken sleeps much more than man—in the winter time twelve hours out of the twenty-four, so that healthful surroundings during sleep are most important for the best condition of the bird.

The plan shown in Fig. 63 is a type of chicken house which has many advocates. It is called the "Open Front," from the fact that the large opening, which should face the south, is

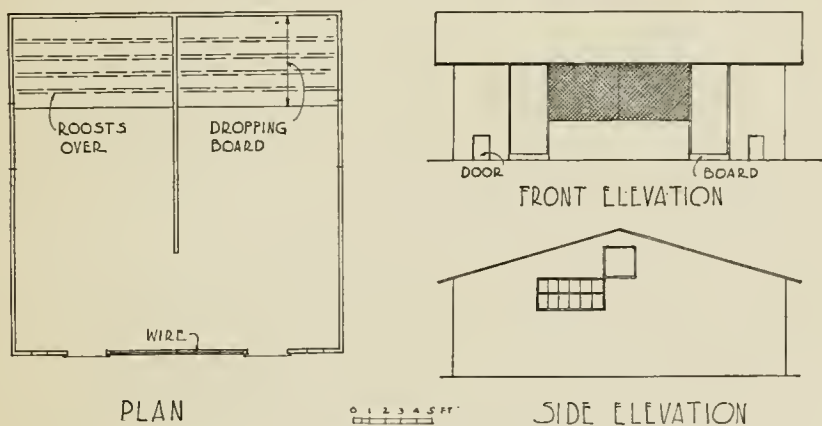

FIG. 63—PLAN OF OPEN FRONT CHICKEN HOUSE

kept open at all seasons of the year. To modify this somewhat in extreme weather, a muslin screen is put in the opening, although this is not at all necessary according to the enthusiast for this type of house. The high windows in the sides are for summer ventilation and should be left open all summer. There is no doubt that the building would be cooler if portions of the roof could be raised in the same manner as shown in Fig. 62.

Where space does not permit the Colony Plan, and the chicken farm must be restricted and the birds confined, the

usual chicken house is a long building, divided into separate pens, these pens being about 8x12 ft., in which are kept from 20 to 25 birds. This allows 4 or 5 sq. ft. of floor space per bird. The best traditions—or superstitions—face this building to the south. The south front is full of windows reaching nearly to the floor, so that as much sun as possible may fall upon the pen floor. A passageway from which the pens are entered is placed at the north, and the north wall has few if any openings in it, so that it may afford perfect protection in winter. For a winter house only, this may do very well, but for the summer a more uncomfortable building could scarcely be designed. There is no possibility of ventilating it, or of allowing a cooling draught of air to blow through it. As has been pointed out before, the important thing, in our climate at least, is to provide a cool building in summer. It is a simple matter to get heat in winter, but it is a very difficult one to devise a building which will be cool on a warm day. A much better disposition of the chicken house would be to run it north and south, as advocated for the cow barn, with large windows and doors on both sides and with chicken yards on each side. Then it would be possible to retain one yard and plant it with suitable crops while the other one was in use. To have two chicken yards that are interchangeable is a great advantage, as the continual use of one causes it to become foul and infected with the germs that are harmful to chicken life. This plan, however, has one disadvantage, as it does away with the passageway behind the pens, although the only use of this is to allow the owner an easy inspection of his fowl. It is not at all necessary however, for the care of the birds themselves, and apart from the owner's comfort, this additional space had better be given over to the flock. What is of great importance for the

chicken house is a dry location. Dampness must be avoided, not only in the building but out of it, and elevated and well drained ground for the site of the chicken house is of prime importance.

In spite of the general use of concrete for the floor, this is not desirable except as a means of keeping out the rats. The floor of the pen itself is best of wood, elevated above the concrete floor, 18 in. or 2 ft. This gives a circulation of air beneath the pen and affords sufficient space to allow a dog to catch any rat seeking shelter there. Such floors are drier than any other type.

All the doors in the pens and yards should be of the double-swing variety, the same hinge being used as that for a butler's pantry door; this hinge permits the door to be pushed open from either side and when released to immediately swing back into position. Doors 2 ft. wide and 6 ft. high are large enough for the average problem. The windows should be numerous on all sides, and blinds, after the manner prescribed for the cow barn, are desirable during the summer. The protection of the fowl in winter by dropping a curtain enclosing the roosts is a good thing, but a little heat throughout the entire house is probably better, though this should mean more ventilation, not less. In the killing-room a dozen small coops are placed in which to confine the chickens preparatory to that operation. All roosts, nests, etc., should be removable for easy cleaning. All dust projections should be eliminated, and the old-fashioned whitewash for interior finish is as good as anything. Fig. 64 shows the plans of a chicken house that was designed to meet, if possible, all objections. Skylights were put in the southern slope of the roof to give additional sunshine in the pens in the winter and also to afford better venti-

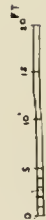
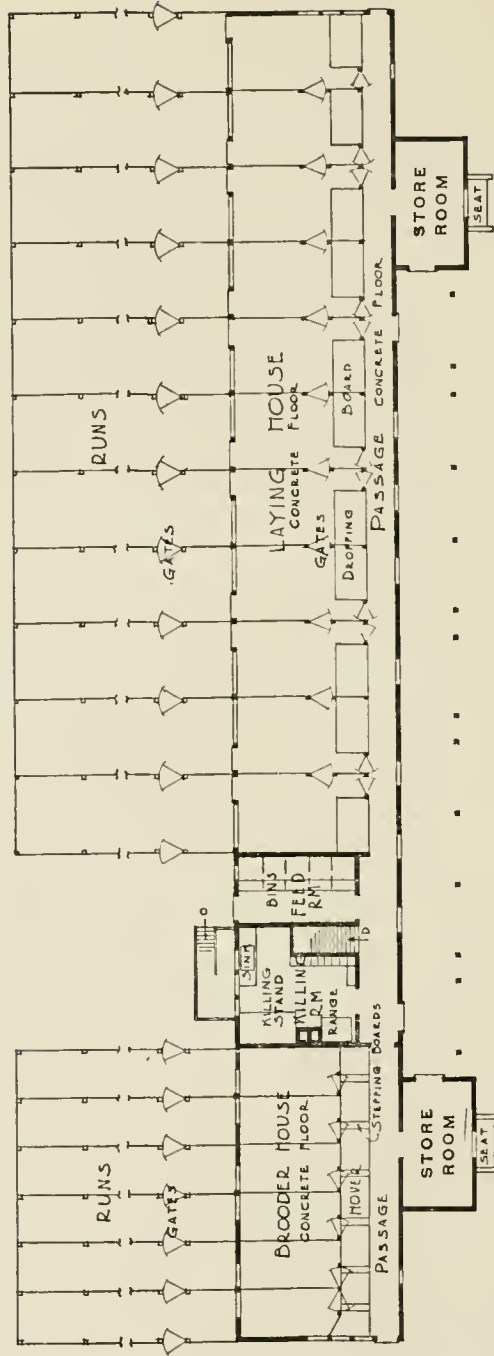

FIG. 64—PLAN OF CHICKEN HOUSE BUILT FOR R. CLIFFORD V. BROKAW, ESQ., AT GLEN COVE, L. I.

lation at all times. In the front of each pen is a door 2 ft. 4 in. wide, the remaining space being taken up by a large window; the sash, divided in the center, is arranged to open in half or entire. By this means the chicken house may be readily converted into the "Open Front" type—from all accounts a very good one. By closing all the windows and doors, it may be made at once into the tightest kind of a "Tight Front" type—from all accounts a very bad one but still de-

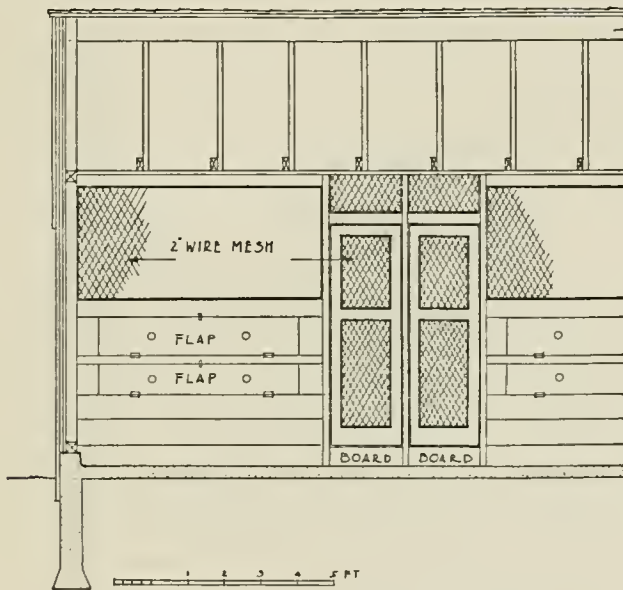

FIG. 65—ELEVATION OF PEN IN PASSAGEWAY

sired by some. The north wall is well ventilated by good-sized windows, which should be left open throughout the summer, though they seldom are. The usual manner of arranging the roosts and nests is shown in Figs. 65 and 66, the nests and the dropping-boards being accessible from the passageway. Plate facing p. 188 shows a photograph of the interior.

For the small plant the commercial outdoor brooder is the best. For the larger scheme the brooder building is a satisfactory structure, and the plan shown in Fig. 64 illustrates the usual type. The important thing in the brooder house is to separate completely the cellar for the incubators from the cellar in which is placed the boiler. It is impossible to prevent the coal gas escaping from the boiler and the fumes of

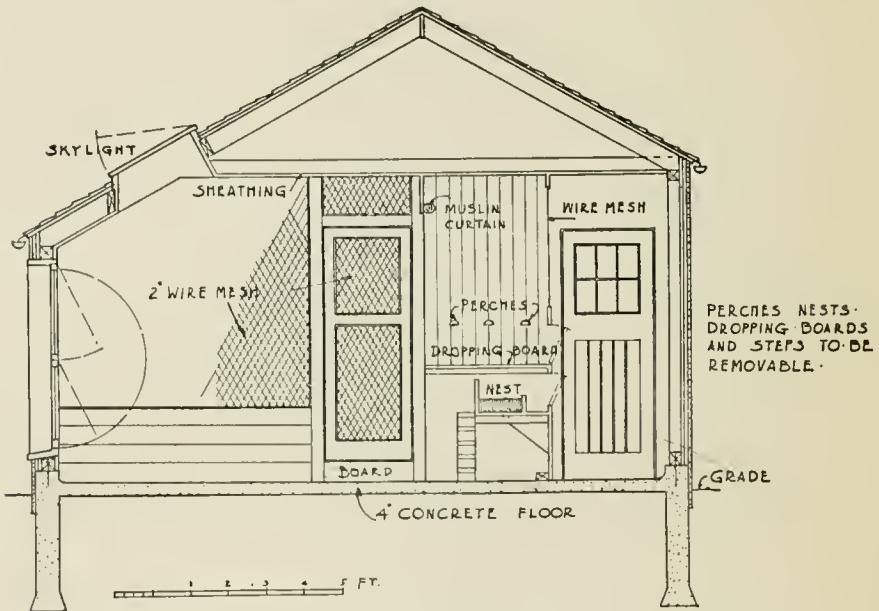
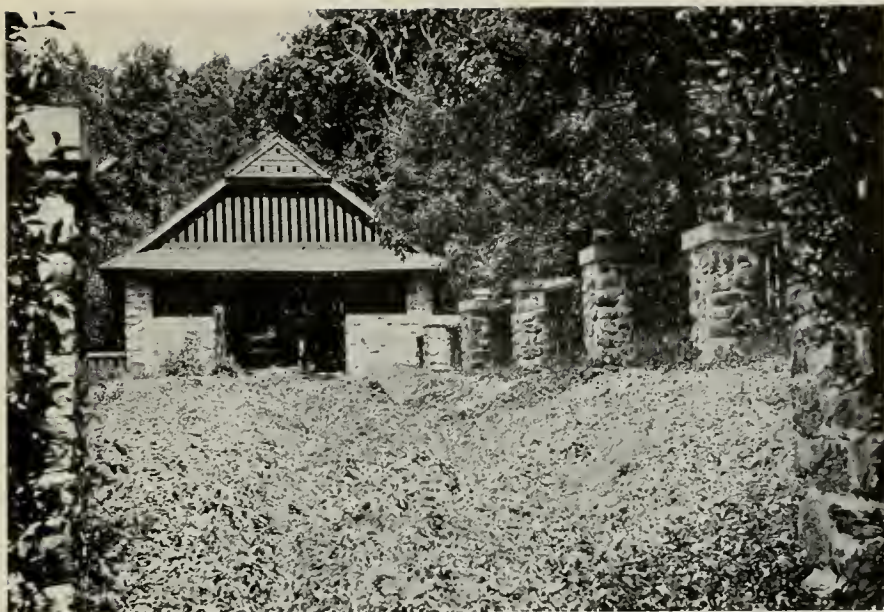

FIG. 66—SECTION THROUGH CHICKEN HOUSE SHOWING NESTS, ETC.

imperfect combustion are harmful to the hatching egg. An independent, well-ventilated cellar, which shall have no entrance except through the outside air, must be provided for the incubators. In the plan, Fig. 64, this cellar is under the end of the building. The store room is a very desirable room to be had in connection with either the chicken or brooder house. In connection with the chicken houses at Sky-



A MANURE PIT TO WHICH A LARGE ENCLOSURE WAS ADDED FOR THE STORAGE OF LEAVES, USEFUL TO THE GARDENER IN VARIOUS WAYS. SKYLANDS FARM



THE INTERIOR OF A CHICKEN HOUSE. THE LARGE WINDOWS FOLD IN THE CENTER AND ARE HOOKED UP AGAINST THE CEILING

lands, a separate storage shed has been provided. For the chicken farm a good-sized storage place is necessary for outdoor brooders and hovers which are out of season, to say nothing of extra coops and shipping-boxes and that inevitable accumulation of things which though hardly fit for use seem yet too valuable to be thrown away.

In the above very brief reference to chicken houses, it is probable that the enthusiast will not find sufficient data with which even to disagree. If he is resolved to have the only perfect chicken plant in existence he will probably wish to read much more than has been written here; and happily there is much more to be read, and the following volumes are suggested for his approval, all of which are exhaustive, and some exhausting, in their treatment of the subject:

The Home Poultry Book, E. I. Farrington.—*McBride, Nast & Co.*

The Beginner in Poultry, C. S. Valentine.—*Macmillan.*

The Practical Poultry Keeper, Lewis Wright.—*Cassell & Co.*

The Principles and Practice of Poultry Culture, John H. Robinson.—*Ginn & Co.*

American Poultry Culture, R. B. Sando.—*A. C. McClurg.*

Poultry and Profit, W. W. Broomhead.—*Cassell & Co.*

Poultry Keeping, Edward Brown, F.L.S.—*Edward Arnold, London.*

The Poultry Book, Harrison Weir.—*Doubleday, Page & Co.*

The New Egg Farm, H. H. Stoddard.—*Orange Judd Co., 1907.*

Philo System of Progressive Poultry Keeping, E. W. Philo.—*E. R. Philo, Elmira, N. Y.*

Open Air Poultry Houses for All Climates, Prince T. Woods, M.D.—*American Poultry Journal Publishing Co.*

SHEEPFOLD

Although a number of the plans of farm barns already illustrated have included quarters for the sheep, yet it is better to keep sheep at a distance from the farmyard, if the best results of breeding and rearing them are to be obtained. The

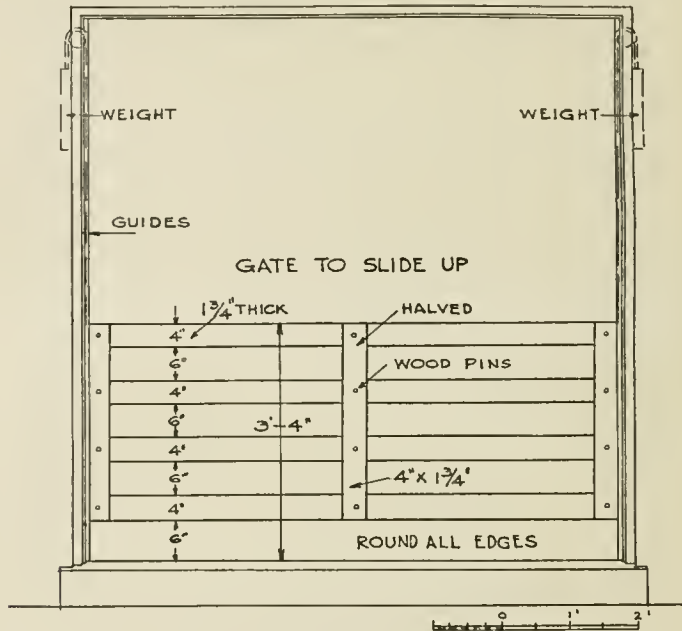

FIG. 67—DETAIL OF SLIDING GATE IN SHEEP PEN DOOR

one vital thing in the sheep barn is ventilation, and any barn which does not provide this will fail.

While many barns of practical sheep breeders are arranged to store the hay overhead, yet a better method is to keep the feed separated from the animals, just as was advocated for the cow barn, and the same reasons for this prevail here as there. A general and a separate storage place for feed is desirable and this should include a cellar for roots.



ENTRANCE TO SHEPHERD'S QUARTERS



SHEEPFOLD FOR FRANCIS LYNDE STETSON, ESQ., STERLINGTON, N. Y.

The usual practice is to run the sheep shed east and west, with the long sides facing the north and south; the southern elevation having as many doors as are possible. There are two ways of arranging this door: the usual one is similar to the Dutch door, the lower part in two folds, each opening out, and the upper part in one fold, opening in and up against the roof or ceiling. In warm weather the upper part may be open while the lower is closed, thereby controlling the egress of the flock. The other way is to provide a large sliding door for the entire opening and in addition there is hung between the jambs a slatted gate which slides up and down (Fig. 67). This gate, balanced by weights, operates very easily. The large door being opened, the gate is left at the bottom of the opening, the slats allowing better ventilation than the solid doors; upon the sheep going out, the slatted door is raised and the flock passes beneath it. In warmer climates, such as our own, the latter is the better type of door, but where long winters and blizzards are usual, the barn can be better ventilated in extreme weather with the Dutch door. The lower half of this door being solid, it affords greater protection; though if the sliding gate, usually made of slats, were built solid, it would be equally effective. The sliding door is always more convenient than the swinging door and is especially recommended in the sheepfold. These doors should never be less than 6 ft. in width and can be increased to 7 ft. or even 8 ft. to advantage. Sheep crowd one another on going in and out of the building, and the widest possible opening is desirable. The doors just described occur in the south front of the sheepfold. It is just as important for proper ventilation to have suitable openings at the north, where long batten shutters, coming within 3 ft. of the floor, should be arranged. These are necessary for

summer ventilation and for the warmer days of winter. The practice of leaving a north wall without openings for protection in winter is bad; such an arrangement may be well enough during a blizzard, but a sheep barn so designed will be a poor one in any but the most extreme cold.

Equal in importance to ventilation is the dryness of the

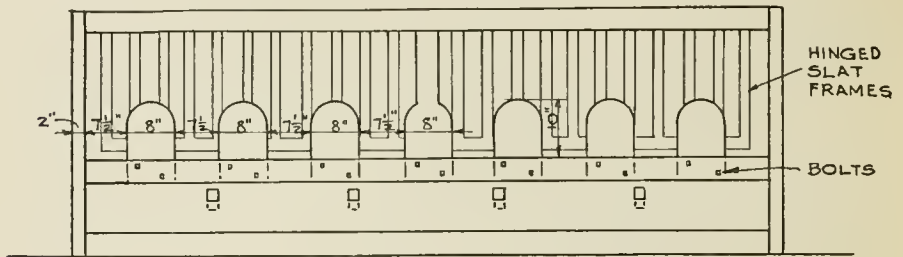

SIDE ELEVATION

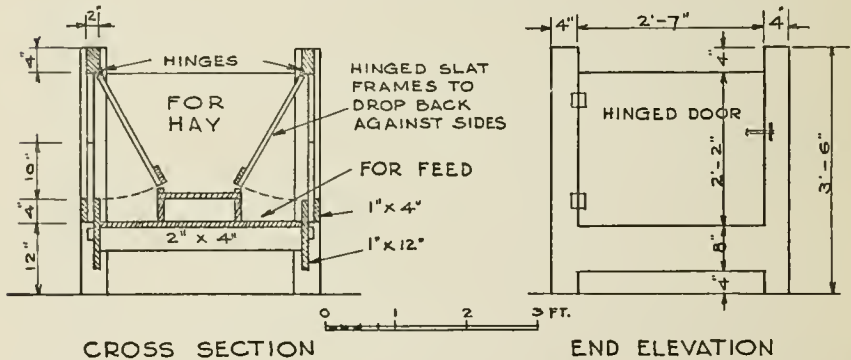

CROSS SECTION

END ELEVATION

FIG. 68.—DETAIL OF SHEEP FEEDING-RACK RECOMMENDED AS MOST ECONOMICAL OF FEED

floor. Sheep do best standing on the natural earth, but this must be invariably kept dry, and consequently the sheepfold should be located only on high ground or on such as can be effectively drained. To make the floor dry beyond question, it is well to fill in the building with a foot or so of broken stone and then to lay 8 or 10 in. of earth upon this.



FEEDING-RACK IN THE SHEEPFOLD, DETAIL OF WHICH IS SHOWN IN FIG. 68, SKYLANDS FARM, STERLINGTON, N. Y.

The best method of dividing the barn into pens is by the feeding-racks, which are always made movable. The type of feeding-rack which allows the sheep to put its head between wide slats and eat the hay (Fig. 68) is preferable to any other. The usual narrow slatted rack (Fig. 69) causes the sheep to pull the hay out of the rack before it is eaten, and much of it is trampled under foot and thereby wasted.

Many small pens for lambing ewes should be provided; these

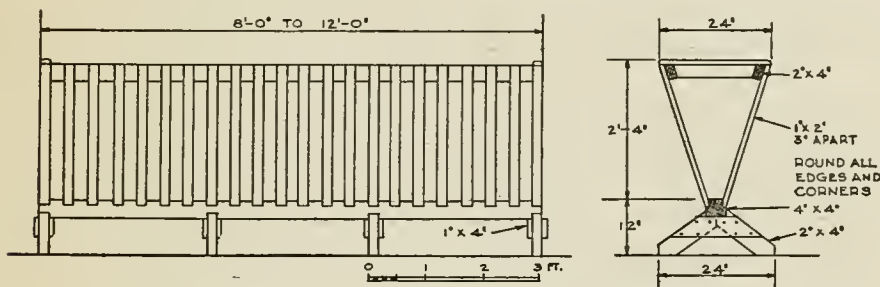

FIG. 69—DETAIL OF USUAL TYPE OF FEEDING RACKS

need not be over 4x5 ft. in size, and are usually arranged so that they may be removed and stored away after the lambing season has passed by (Fig. 70). These pens should always be placed in a room which can be artificially heated. This is the only heat necessary in the sheepfold, except in the shepherd's rooms, for which warmth should always be provided, as his presence is very necessary during the lambing season, when he not only officiates as attendant and head nurse, but frequently as a foster mother as well; for it sometimes happens that a lamb left an orphan at birth must be brought up on the bottle by the shepherd himself.

Fresh water should be had at all times at the sheep pen, and if the water supply is sufficient to afford continuous running water, ideal conditions have been obtained. Sheep are

particularly sensitive with regard to water and quickly detect any foulness in it. Troughs should be arranged so that the sheep may drink at any time. In computing the size of the sheep cote allow 20 sq. ft. for each ewe, outside of all passage-

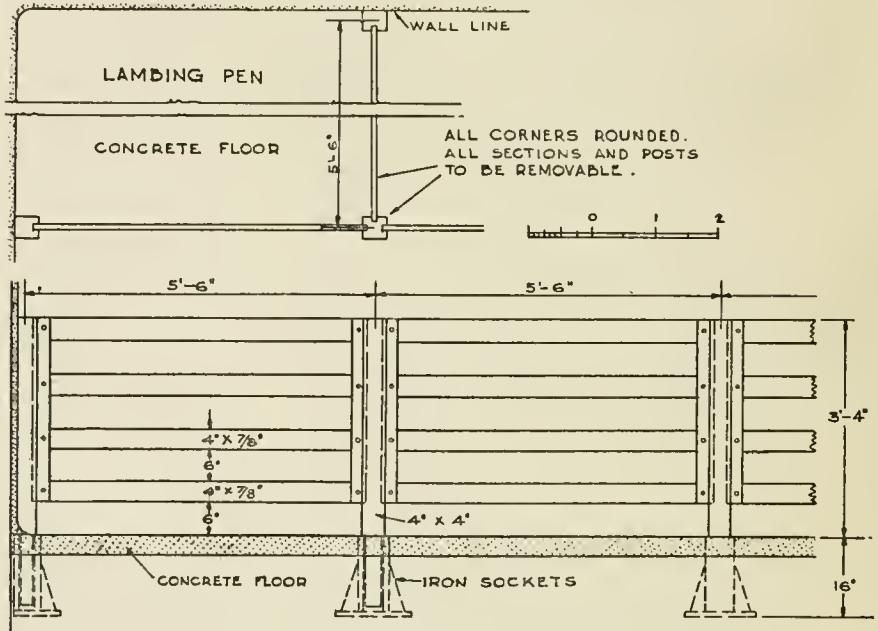

FIG. 70—DETAIL SHOWING REMOVABLE LAMBING PEN PARTITIONS

ways. Fig. 71 gives the plan of the sheepfold at Sterlington, N. Y., in which all the above suggestions have been incorporated and which will explain and amplify them.

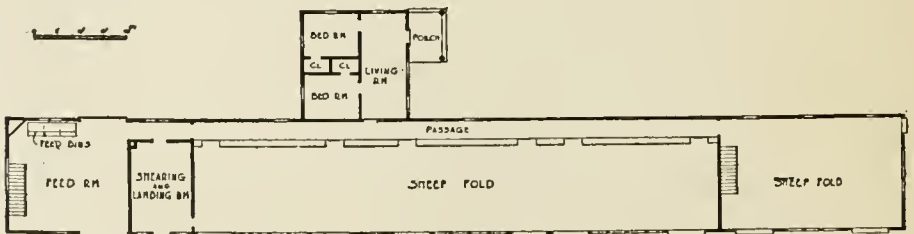

FIG. 71—PLAN OF SHEEPFOLD AT STERLINGTON, N. Y., FOR FRANCIS LYNDE STETSON, ESQ.



THE NORTH WALL.



Designed by Harlo J. Fiske
THE SOUTH WALL. THERE ARE NO RUNS HERE, THE PIGS GOING
DIRECTLY INTO THE MANURE PIT. THE PIGGERY, SKYLANDS FARM,
STERLINGTON, N. Y.

MANURE PIT AND PIGGERY

The author has not been as successful as he could wish in inducing the gentleman farmer to believe that in his piggery he has architectural possibilities of which advantage should be taken. The owner, when he comes to consider his pigs, is usually content to treat them as pigs, and to house them accordingly. Still, the piggery may show some taste in its design, and, like the other buildings of the farm, need not be ugly in order to be practical. As the practical phase of the problem is the important one we will commence there and leave the artistic side to that fortunate man who finds pleasure in considering the appearance of even the humblest of the farm buildings.

A common disposition is to locate the piggery adjoining the manure pit, where the pigs, rooting in the manure, work it up and hasten its rotting. Such treatment of the manure produces excellent results in preparing it for the land, and on large estates such a combination of pit and piggery is very desirable. To properly contain the manure nothing more is needed than a concrete platform surrounded by a wall. It is better without a roof; and, if the site permits the drawing off of the liquids from a lower level into a sprinkling-cart, all the benefits of a manure pit have been obtained. Some farmers prefer a roof over the manure, and if this is provided, a hose outlet for wetting it down must also be arranged. Ordinarily, the rain will not be more than is good for the manure; but in an unusually wet season the uncovered manure pit may hold too much water, in which case the drawing off of it into a cart is an advantage, and the liquid so obtained is more valuable than the manure itself for fertilization. Plate facing p. 188

shows the usual method of constructing the manure pit when this is roofed over. The sides, being of slats for the purpose of ventilation, also serve as a screen.

We will now leave the manure pit and return to the piggery; and first of all to that part of it which is the most important, as it is the most apparent, namely, its ventilation. Vent ducts are a help, but they have to be numerous, and so large that it is better to rely on openings in the side walls front and back for the taking off of odors. These openings—

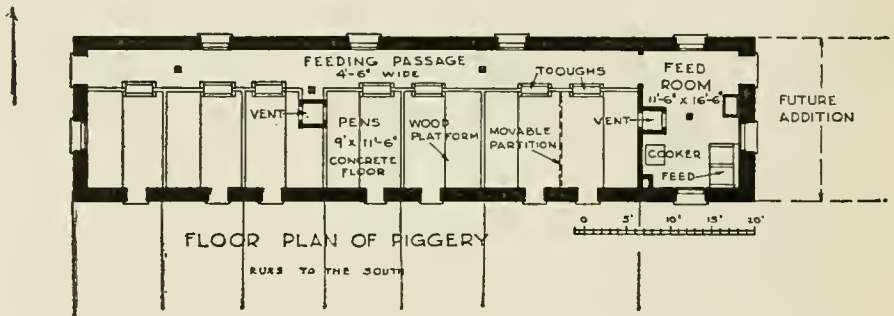

FIG. 72—PLAN OF PIGGERY AT GREENWICH, CONN., FOR DR. J. CLIFTON EDGAR

windows in the front and shutters in the back—ought to be as numerous as possible, and in the summertime should be left open night and day.

Fig. 72 shows a usual plan for the piggery, in which large ventilating ducts are installed. As they were operated, these were not sufficient to take off the odors. Plate facing p. 195 shows a photograph of the north and south walls of a piggery, both walls with a continuous row of openings. This building is practically free from odor and this is the only way to really ventilate the piggery.

The piggery is usually faced south with the passageway at the north. The pens may vary in size, 8x10 ft. being a fair

average, and one or more larger pens, 10x12 ft., should be provided for a sow and her litter. Fig. 73 shows the floor of the pen which may well be made of concrete provided that a portion of it, where the animal sleeps, has a wood covering. The concrete floor is better left in front of the feeding-trough,

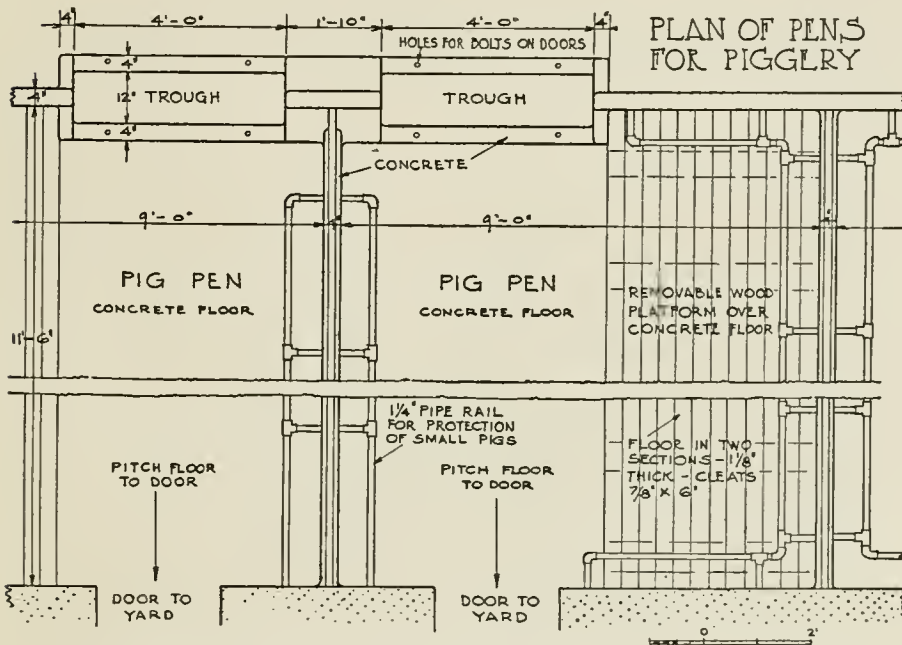
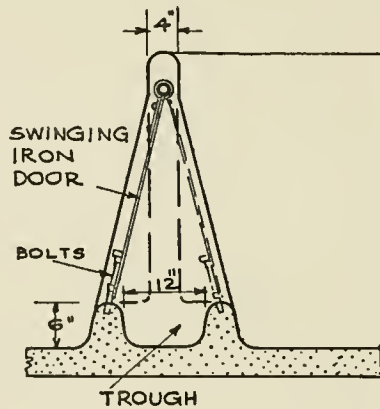

FIG. 73—DETAIL OF PEN FLOOR SHOWING PIPING IN FARROWING PENS

where the hosing out of the trough is likely to wash the adjacent floor. A bell trap should never be placed in the pen floor, as this becomes foul beyond description. The pen should drain to the outside through the pen door and then into a continuous gutter, run the length of the piggery. Where the piggery connects immediately with the manure pit, the pens need drain only through the door and then into the manure

pit. Care should be taken to locate the piggery on high, well-drained ground, so that a dry building may at all times be assured. A bell trap in the passageway is necessary, though as just pointed out, one must never be put inside the pen.

A very necessary thing in the farrowing pens is a 2-in. pipe railing 10 in. out from the side walls and the same height above the floor; this prevents the sow from rolling over on one of her progeny and killing it. The pipe rail keeps her away from



SECTION AT TROUGH

FIG. 74—SECTION THROUGH FEEDING TROUGHS

the wall and gives the little one a space through which he may escape. The pen partition walls are best made of concrete, troweled to a hard smooth finish. The feeding-troughs are made as shown in Fig. 74. A door hung at the top and swinging over the trough, makes it possible to separate the animal from the feed while it is being prepared. When the meal is ready the door is swung to the outside of the trough, when the trough itself comes within the pen.

It is curious to note that in an old volume on farm buildings,

published in 1833,¹ which the author picked up in a second-hand book store in Oxford, the pig trough is shown arranged in just this manner. The door from the pen to the yard is frequently hung at the top in the same fashion, and, to quote from the volume of 1833, its advantages are as follows:

“The use of the swing door, which is nothing more than a frame of boards suspended from a rail, the ends of which move in sockets freely either way between the jambs of the door, is to prevent the door from ever being left open in severe weather. When the pig wishes to go out, he soon learns to push it before him; and the same when he wishes to return.”

This method is still in use and remains an entirely satisfactory one.

In connection with the piggery there should be a small feed room with a chimney. A cooker is always necessary, and the best method of cooking is with live steam. As in the cow barn, the steam may be used also in washing out the troughs and pens. Only with live steam can real cleanliness be assured. In the selection of materials, concrete is the best; wood the least desirable. Though the wooden floor in a portion of the pen is advisable, yet it should always be installed so as to be readily removed and must be renewed before, not after, it becomes foul. With the single row of pens, the best exposure for the piggery is with its long axis east and west. With the double row of pens, its long axis is better north and south, so that the yards may have an easterly and westerly exposure.

Fig. 75 shows a very interesting piggery, and a type that should be generally adopted. It was built at Islip and de-

¹ Loudon's *Encyclopedia of "Cottage, Farm and Villa Architecture and Furniture,"* London, 1833, a volume of some 1138 pages. It contains many designs of "Model Farms," some of which quite surpass in extent any of those set forth here.

signed by Mr. H. T. Peters. Its great advantage over the usual piggery is in the location of the feeding-troughs, which are in the yards and *not in the pens*. The foulness of the odors in a piggery comes very largely from the feed; taking this out of the building is of the greatest importance, and

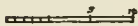
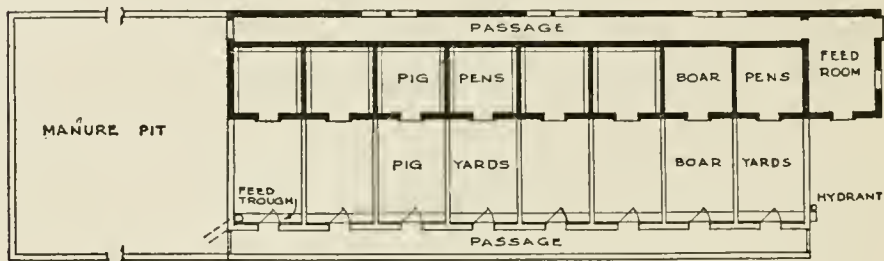

FIG. 75—PLAN OF PIGGERY AT ISLIP, L. I.

with the feed trough in the yard the pens themselves can be kept in a much more sanitary condition. The trough is continuous—another advantage in its cleanliness, for it is readily hosed down and washed out. The plate facing p. 174 shows a photograph of the exterior which will explain the plan more clearly. It is an admirable arrangement.

ROOT CELLAR

Where roots are intended to be used as feed, it is usual—as it is more convenient—to put them below the feed room, where they may be readily obtained and prepared. As previously pointed out, such root cellars are likely to freeze in extreme cold weather, and some method for heating them under such conditions should be provided. The best way to do this is to build a chimney containing a large flue, 16x20 in., which does service as a ventilating flue when not in use as a

chimney. Ventilation for the root cellar is as important in preventing undesirable conditions as ventilation for the cow barn or horse stable. Roots mold and spoil very quickly if deprived of a circulation of air, so that the root cellar must be so ventilated as to insure a circulation of air throughout every part of it. The volume of fresh air here need not approach in extent that required by the buildings for housing the animals. If the ventilation is arranged so that the air will come in at the extreme end and be taken out at the other, it will provide all that is necessary.

There seems to be a difference of opinion as to whether the floor is better of earth or concrete. Some farmers prefer the latter, for its possibilities of cleanliness, while others will tolerate nothing for the storage of roots but the soil in which they are grown. The character of the site and the position of the cellar with respect to it are important factors. A dry cellar must be assured at all times, and good drainage and a sandy soil are the necessary natural conditions. If such conditions prevail, the root cellar is best without a concrete floor. Where other considerations place the farm buildings on low ground, every precaution should be taken to provide a dry cellar—waterproofed floors and walls and careful drainage of the foundation. After a dry place has been provided, sand may be put in over the concrete floor.

The difficulty of the root cellar under the feed room is that it frequently thrusts the cellar so deep in the ground that in some localities it is difficult to keep it dry. To obviate this the author has tried several times to construct a root cellar above ground, forming the walls of three thicknesses of building tile or of studding, and filling the spaces between with sawdust or granulated cork. This construction has been

entirely successful in keeping the contents from freezing, but only when this room has been placed in the farm building (Fig. 36). For the isolated root cellar the only satisfactory one is found by going into the side of a bank and constructing a chamber whose top as well as sides

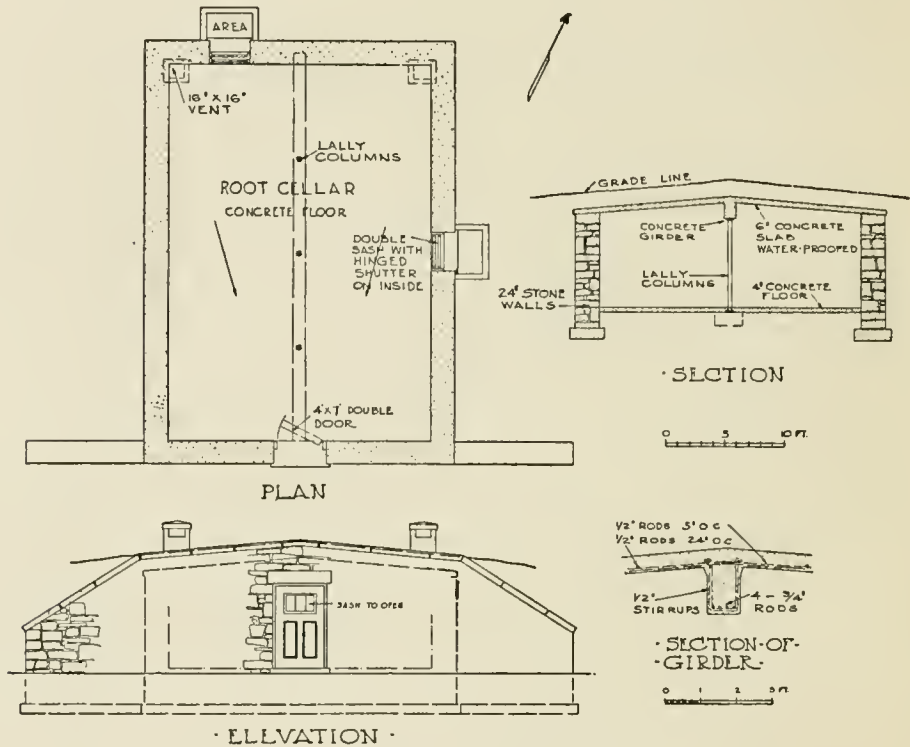

FIG. 76—PLAN OF ROOT CELLAR

are completely covered by the earth. (Fig. 76.) The ground above the top should be at least 3 ft. deep; the entrance—the one side exposed to the air—had best face south, though its exposure may incline to the east or west but never to the north. Ventilation must be provided, which can be arranged by an inlet in the door and a flue carried up above the ground

at the back. Though this is a perfect type of root cellar, it is not automatic with all degrees of temperature, and some regulation of the ventilation is necessary in extreme weather conditions. A concrete roof, which must drain as shown, is the best. In fact such a structure is practically indestructible and should serve its purpose as long as it is put to its use.

ICE HOUSES

After many experiments in building ice houses of various materials and placing them in various stages between entirely above and entirely below ground, it has been pretty well demonstrated that the structure of wood, placed if possible in the shade and constructed as shown in Fig. 77, serves its purpose better than any other type of construction. The plan as drawn calls for a building of 6-in. studs, sheathed on both sides and filled between with sawdust. Upon the outside sheathing and placed vertically, are 2x4-in. studs, 24 in. apart, also sheathed or clapboarded and forming a 4-in. air space around the entire building. This space, left open at the bottom and at the top, allows the air as it becomes heated by the rays of the sun to pass up and out. A ceiling is formed at the level of the tie beams, insulated with sawdust in the same manner as the side wall. It is necessary to ventilate the space between the ceiling and the roof, which in small houses (under 200 tons) is adequately done by louvers at each end. In larger houses an additional ventilator—or two ventilators—on the roof is desirable. The earth itself forms the best floor, although it should be supplemented by a foot or eighteen inches of sawdust, upon which the ice is laid. The sawdust and the earth will absorb whatever water may result from melting ice. A bell trap should never be put in the floor, as this allows the

air to reach the ice and invariably causes it to melt faster at that point. The nearer the mass of ice intended to be stored approaches a cube, the better it will keep. With the construction described above, the ice may be put directly against the

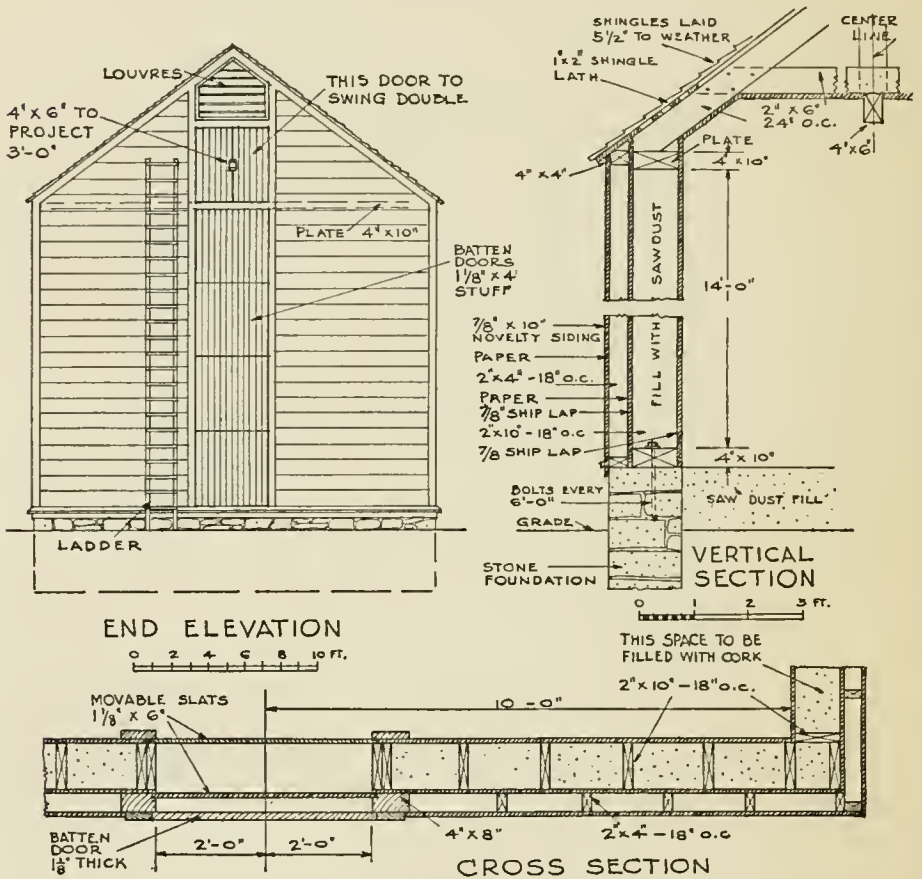
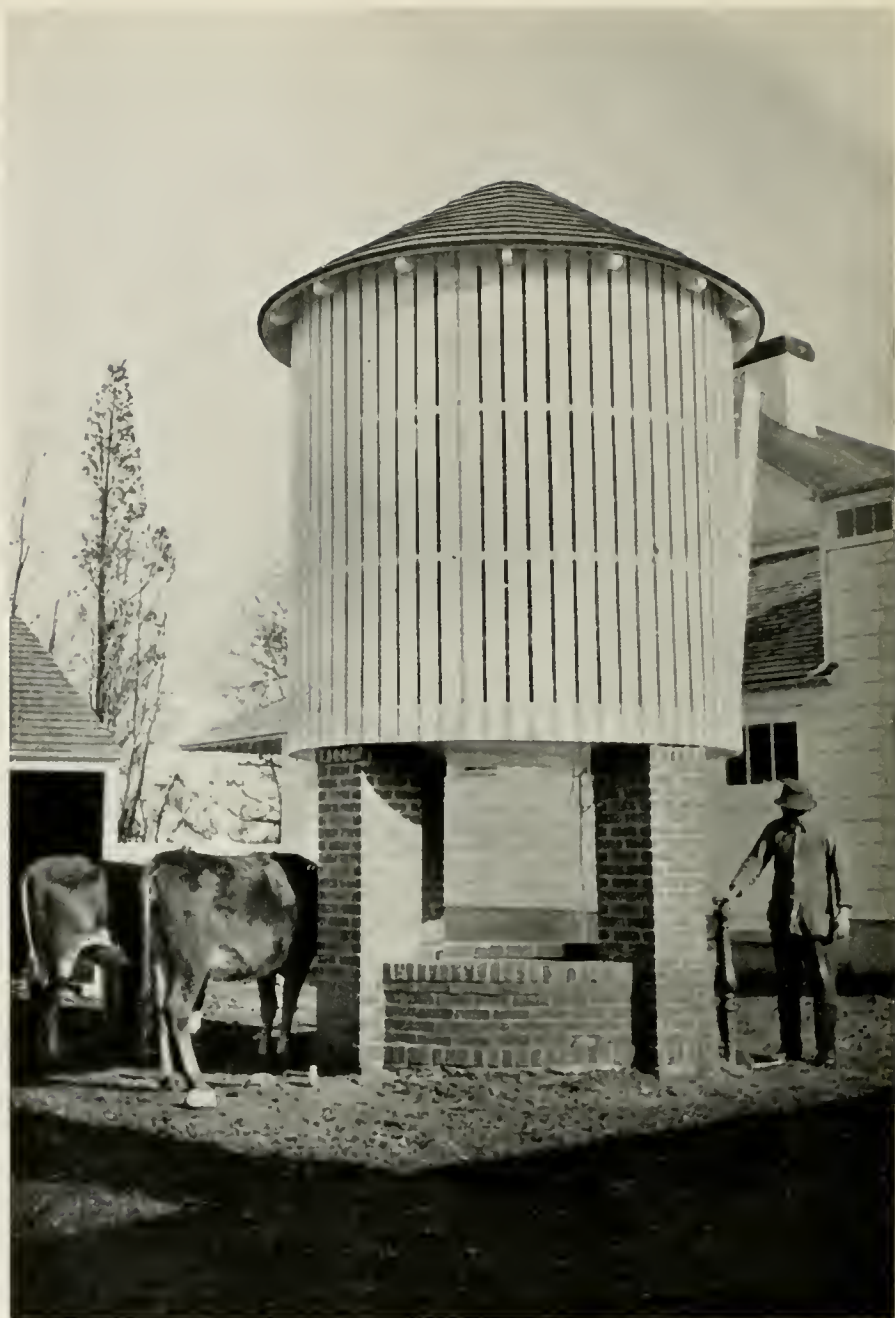

FIG 77.—ELEVATION AND DETAIL OF ICE HOUSE

outside wall, and with ice so placed 45 cu. ft. of space is allowed for every ton.

It seems impossible to do anything with the ice house towards making it slightly. The only thing, therefore, is to keep



CORN CRIB. FARM BUILDINGS FOR CLIFFORD V. BROKAW, ESQ.,
GLEN COVE, L. I.

it out of sight, and the woods—a dense woods—is the best place for it.

The author never builds an ice house, nor thinks of one, without recalling to mind an experience he had some years ago in connection with the construction of a large ice house at Skylands Farm. Wishing to obtain as much reliable information as possible, he went to see the manager—in fact the president—of one of the largest ice companies in New York, to profit by his experience and his advice. The author, after dwelling at somewhat greater length upon his own views than he had intended—a not infrequent occurrence with those who seek the views of others, was replied to by the managing president somewhat as follows: “Well, we have built ice houses of wood, we have built ice houses of brick, we have built ice houses of stone, and put them above ground and below ground; we have ice houses along the Hudson that hold 50,000 tons of ice, and the building which keeps ice the best is the one I have described to you. Your theories are interesting, but my grandmother used to say that one fact was worth a dozen theories.”

This conversation took place some six or seven years ago and resulted, not only in the design of the ice house shown in Fig. 77, but, on the part of its architect, in an enduring appreciation of the wisdom of that grandmother.

CORN CRIB

The corn crib can be included in the general plan for the farm barn so that it may be convenient to use and also add its note of interest to the general scheme. The practical requirements consist of providing a storage place where the corn may be dried out by the air and be protected from the foraging

parties of rodents which usually inhabit the barnyard and the field. To this end the inverted tin pan, which the farmer has placed atop the foundation posts of his corn crib, at once occurs to mind; this method is characteristic and effective, and consequently architecturally appropriate.

A not unusual style of corn crib is that shown in the plate opposite, arranged so that a wagon may be driven through it and unloaded into either side. This middle space also serves as additional shed room—a place in which to hitch a visiting farmer's horse during a friendly call. This same plate shows a better method still for increasing the shed room by utilizing the shelter afforded by the corn crib, and the author is indebted for this idea not to his own imagination but that of a client, Mr. W. P. Hamilton. Here the corn crib has been raised bodily, high enough above the ground to allow a horse and cart to be driven beneath. Each concrete post had cast into it a heavy hitching ring, and no horse as yet has succeeded in reproducing for himself what is told in the story of Sampson. This little building was placed in the center of the farmyard, where it has served its double purpose well.

In the plate facing page 205 a small corn crib has been placed over the watering-trough in the cow yard of a group of buildings designed to accommodate six cows. It has been raised high enough above the water so as not to interfere with the cattle's drinking, while the water below may have some effect in deterring the rat who would seek the corn above it.



CORN CRIB OF A TYPE FREQUENTLY USED BY THE FARMER



CORN CRIB. FARM BUILDINGS FOR W. P. HAMILTON, ESQ.,
STERLINGTON, N. Y.

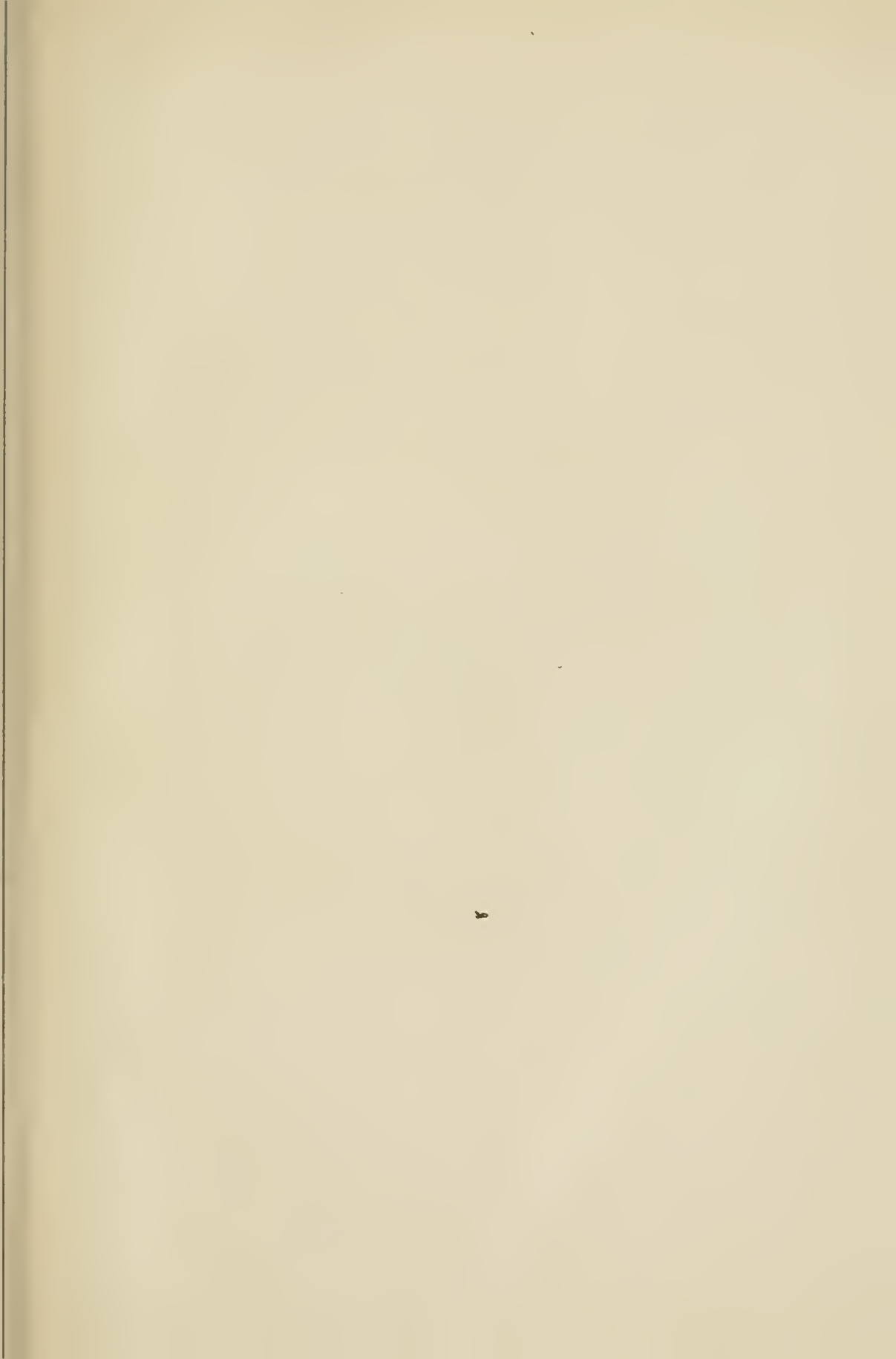

University of California
SOUTHERN REGIONAL LIBRARY FACILITY
305 De Neve Drive - Parking Lot 17 • Box 951388
LOS ANGELES, CALIFORNIA 90095-1388

Return this material to the library from which it was borrowed.

D 000 571 806 9

UCLA-AUPL
NA 8201 H6



L 005 857 328 8

Date Due

MAY 24 1973
REC'D AUG 29 1973
AUPL

